



US009270427B2

(12) **United States Patent**
Blankenship et al.

(10) **Patent No.:** **US 9,270,427 B2**
(45) **Date of Patent:** **Feb. 23, 2016**

(54) **SYSTEM AND METHOD FOR MULTIPLEXING CONTROL AND DATA CHANNELS IN A MULTIPLE INPUT, MULTIPLE OUTPUT COMMUNICATIONS SYSTEM**

(75) Inventors: **Yufei Blankenship**, Kildeer, IL (US);
Weimin Xiao, Hoffman Estates, IL (US);
Ying Jin, Shanghai (CN)

(73) Assignee: **Futurewei Technologies, Inc.**, Plano, TX (US)

(*) Notice: Subject to any disclaimer, the term of this patent is extended or adjusted under 35 U.S.C. 154(b) by 584 days.

(21) Appl. No.: **12/856,333**

(22) Filed: **Aug. 13, 2010**

(65) **Prior Publication Data**

US 2011/0170625 A1 Jul. 14, 2011

Related U.S. Application Data

(60) Provisional application No. 61/293,985, filed on Jan. 11, 2010.

(51) **Int. Cl.**
H04L 27/00 (2006.01)
H04L 5/00 (2006.01)
H04L 1/00 (2006.01)

(52) **U.S. Cl.**
CPC **H04L 5/0023** (2013.01); **H04L 1/007** (2013.01); **H04L 1/0073** (2013.01); **H04L 5/006** (2013.01); **H04L 5/0055** (2013.01); **H04L 5/0057** (2013.01); **H04L 1/0026** (2013.01)

(58) **Field of Classification Search**
CPC H04L 1/0026; H04L 1/06; H04L 1/0618; H04L 1/0003; H04L 5/0023; H04B 7/0413; H04B 7/0617; H04B 7/0669
USPC 375/295, 299; 370/355
See application file for complete search history.

(56) **References Cited**

U.S. PATENT DOCUMENTS

2008/0186934 A1 8/2008 Khan et al.
2009/0304109 A1* 12/2009 Kotecha 375/299

(Continued)

FOREIGN PATENT DOCUMENTS

CN 101536358 A 9/2009
CN 101695017 A 4/2010

(Continued)

OTHER PUBLICATIONS

3rd Generation Partnership Project, "Technical Specification Group Radio Access Network; Evolved Universal Terrestrial Radio Access (E-UTRA); Physical Channels and Modulation," Release 9, Dec. 2009, 3GPP TS 36.211 V9.0.0, 85 pages.

(Continued)

Primary Examiner — Daniel Washburn

Assistant Examiner — Fitwi Hailegiorgis

(74) *Attorney, Agent, or Firm* — Slater & Matsil, LLP

(57) **ABSTRACT**

A system and method for system and method for multiplexing control and data channels in a multiple input, multiple output (MIMO) communications system are provided. A method for transmitting control symbols and data symbols on multiple MIMO layers includes selecting a first set of codewords from N_{cw} codewords, distributing control symbols onto the first set of layers, placing data symbols of the first set of codewords onto the first set of layers, placing data symbols of the $(N_{cw} - N_{cw1})$ remaining codewords to remaining layers if $N_{cw} > N_{cw1}$, and transmitting the multiple MIMO layers. The first set of codewords is associated with a first set of layers from the multiple MIMO layers, and the N_{cw} codewords are to be transmitted simultaneously and the first set of codewords comprises N_{cw1} MIMO codewords, where N_{cw} and N_{cw1} are integers greater than or equal to 1. The remaining layers are MIMO layers from the multiple MIMO layers not in the first set of layers.

46 Claims, 6 Drawing Sheets

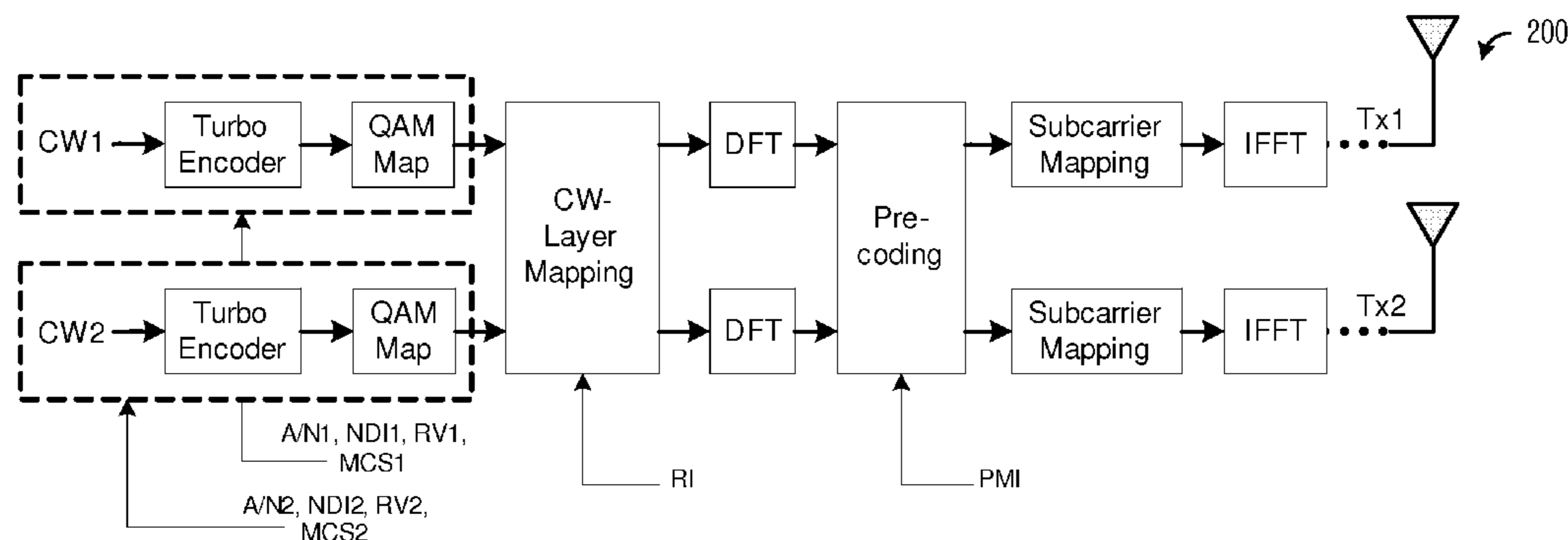

(56)

References Cited

U.S. PATENT DOCUMENTS

2010/0002790	A1	1/2010	Onggosanusi et al.	
2010/0027697	A1	2/2010	Malladi et al.	
2010/0034310	A1	2/2010	Nam et al.	
2010/0041350	A1	2/2010	Zhang et al.	
2010/0067512	A1	3/2010	Nam et al.	
2010/0080154	A1	4/2010	Noh et al.	
2010/0098012	A1	4/2010	Bala et al.	
2010/0195566	A1	8/2010	Krishnamurthy et al.	
2010/0195594	A1	8/2010	Seo et al.	
2010/0195615	A1	8/2010	Lee et al.	
2010/0195624	A1*	8/2010	Zhang et al.	370/335
2010/0202561	A1	8/2010	Gorokhov et al.	
2010/0208680	A1	8/2010	Nam et al.	
2010/0239040	A1	9/2010	Beluri et al.	
2010/0246705	A1	9/2010	Shin et al.	
2010/0322343	A1	12/2010	Yeon et al.	
2011/0019764	A1	1/2011	Chung et al.	
2011/0057218	A1	3/2011	Sorg et al.	
2011/0103498	A1	5/2011	Chen et al.	
2011/0142107	A1	6/2011	Pan et al.	
2011/0228759	A1	9/2011	Futagi et al.	
2011/0274075	A1*	11/2011	Lee et al.	370/329
2013/0128845	A1	5/2013	Cheon et al.	

FOREIGN PATENT DOCUMENTS

CN	101702631	A	5/2010
CN	101807974	A	8/2010
JP	2010-87634	A	4/2010
JP	2010-541222	A	12/2010
JP	2011-526094	A	9/2011
JP	2012-516622	A	7/2012
KR	20110039574	A	4/2011
RU	2298876	C2	5/2007
WO	WO 2009/042290	A1	4/2009
WO	WO 2009/110759	A2	9/2009
WO	2009128604	A1	10/2009
WO	WO 2010/032953	A2	3/2010
WO	WO 2010/064407	A1	6/2010
WO	WO 2010/087641	A2	8/2010
WO	WO 2010/101414	A2	9/2010

OTHER PUBLICATIONS

Notification of Transmittal of the International Search Report and Written Opinion of the International Searching Authority, or the Declaration, International Application No. PCT/CN2010/07662, Applicant: Huawei Technologies Co., Ltd., et al., Mailing Date: Dec. 16, 2010, 14 pages.

"Multiplexing of Control and Data in Multi-layer PUSCH Transmission," 3GPP TSG RAN WGI meeting 59#BIS, Agenda item 7.3.3, R1-100261, Jan. 18-22, 2010, 6 pages.

"3rd Generation Partnership Project; Technical Specification Group Radio Access Network; Evolved Universal Terrestrial Radio Access (E-UTRA); Physical Channels and Modulation (Release 8)," 3GPP TS 36.211, V8.8.0, Sep. 2009, 83 pages.

"3rd Generation Partnership Project; Technical Specification Group Radio Access Network; Evolved Universal Terrestrial Radio Access (E-UTRA); Physical layer procedures (Release 8)," 3GPP TS 36.213, V8.8.0, Sep. 2009, 77 pages.

"3rd Generation Partnership Project; Technical Specification Group Radio Access Network; Further Advancements for E-UTRA Physical Layer Aspects (Release 9)," 3GPP TR 36.814, V1.5.0, Nov. 2009, 53 pages.

"3rd Generation Partnership Project; Technical Specification Group Radio Access Network; Evolved Universal Terrestrial Radio Access (E-UTRA); Multiplexing and channel coding (Release 8)," 3GPP TS 36.212, V8.8.0, Dec. 2009, 60 pages.

Alcatel-Lucent Shanghai Bell, "HARQ Bundling with Layer Shifting for LTE-Advanced Uplink SU-MIMO," 3GPP TSG RAN WG1 Meeting #57, R1-092163, May 4-8, 2009, 5 pages, San Francisco, CA.

"Extended European Search Report," Application No. 10841932.6, Applicant: Huawei Technologies Co., Ltd., Sep. 28, 2012, 11 pages. QUALCOMM Europe, "Further Link Analyses of SU-MIMO Operation of UL of LTE-A," 3GPP TSG-RAN WG1 #58bis, Agenda item: 7.6.3, R1-094222, Oct. 12-16, 2009, pp. 1-9.

ZTE, "UCI Multiplexing on PUSCH with MIMO Transmission," 3GPP TSG-RAN WG1 Meeting #61bis, Agenda item: 6.4.2, R1-103601, Jun. 28-Jul. 2, 2010, pp. 1-4.

Samsung, "Further Discussion on Data and Control Multiplexing in UL MIMO Transmissions," 3GPP TSG RAN WG1 #61bis, Agenda item: 6.4.2, R1-103675, Jun. 28-Jul. 2, 2010, pp. 1-6.

Ericsson, et al., "Resource Allocation for UCI on PUSCH," TSG-RAN WG1 #61bis, Agenda item: 6.4.2, R1-103845, Jun. 28-Jul. 2, 2010, 11 pages.

LG Electronics, "UCI Multiplexing for Multi-layer PUSCH Transmission," 3GPP TSG RAN WG1 #61bis, Agenda item: 6.4.2, R1-103974, Jun. 28-Jul. 2, 2010, 5 pages.

Motorola, "UCI Multiplexing on PUSCH in UL-MIMO Transmissions," 3GPP TSG RAN1#61b, Agenda item: 6.4.2, R1-103916, Jun. 28-Jul. 2, 2010, 7 pages.

Alcatel-Lucent Shanghai Bell, et al., Further Discussions on UCI Multiplexing on PUSCH in case of SU-MIMO, 3GPP TSG RAN WG1 Meeting #61bis, Agenda item: 6.4.2, R1-104163, Jun. 28-Jul. 2, 2010, pp. 1-5.

Samsung, "Further Discussion on Data and Control Multiplexing in UL MIMO Transmissions," 3GPP TSG WG1 #62, Agenda item: 6.4.2, R1-104614, Aug. 23-27, 2010, pp. 1-8.

Ericsson, et al., "Resource Allocation for UCI on PUSCH," TSG-RAN WG1 #62, Agenda item: 6.4.2, R1-104953, Aug. 23-27, 2010, 8 pages.

First Office Action of Chinese Application No. 201080034158.0, mailing date: Jul. 12, 2013, 10 pages (partial translation).

Chinese Search Report for Application No. 2010800341580, mailing date: Jun. 25, 2013, 2 pages.

"Notice of Reasons for Rejection," Japanese Patent Application No. 2012-534527, mailing date: Jul. 2, 2013, 10 pages.

"Japanese Decision of Refusal," Patent Application No: 2012-534527, Applicant: Huawei Technologies Co., Ltd., mailing date: Mar. 18, 2014, 4 pages.

"Russian Notice of Allowance," Application No. 2012116338/07, mailing date: Oct. 31, 2013, 9 pages.

* cited by examiner

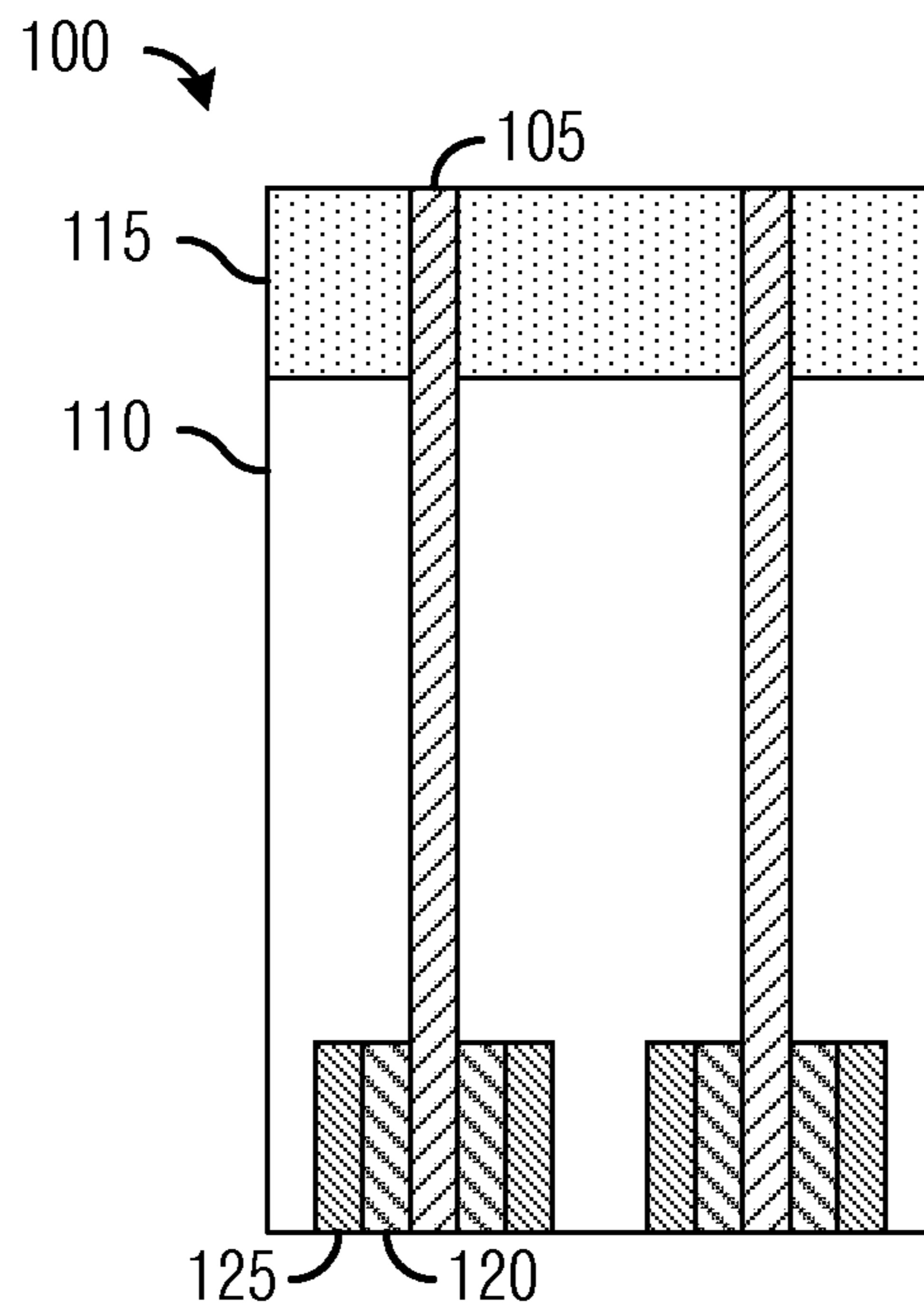

Fig. 1

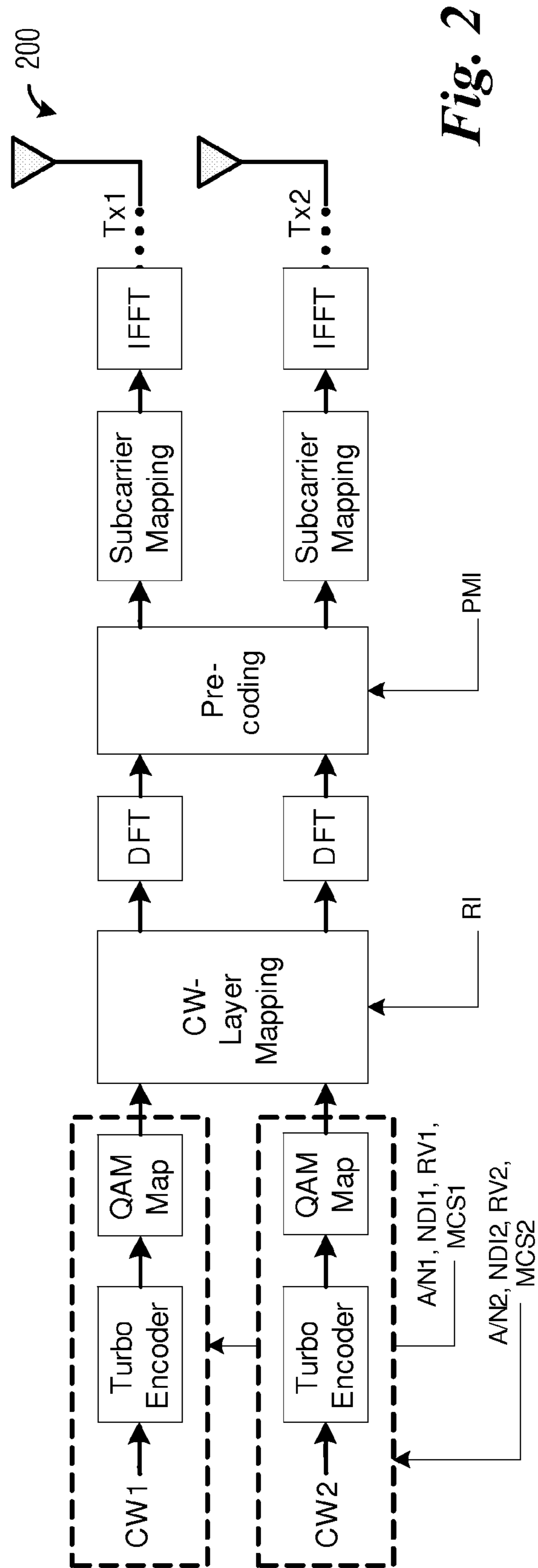

Fig. 2

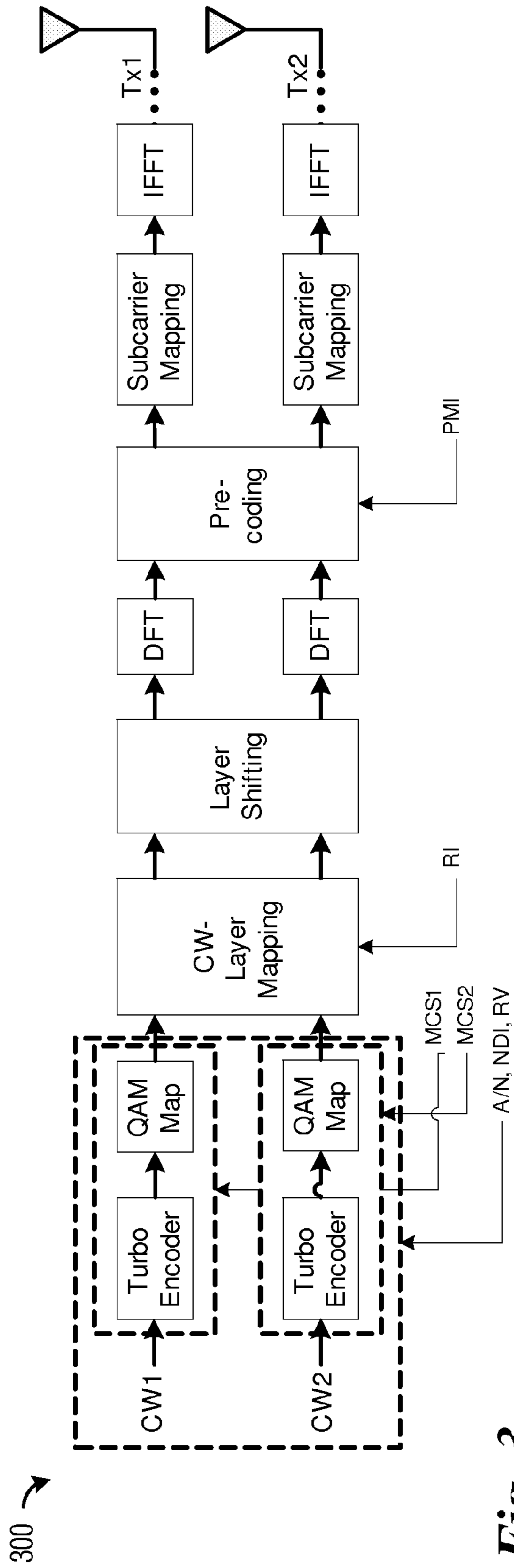

Fig. 3

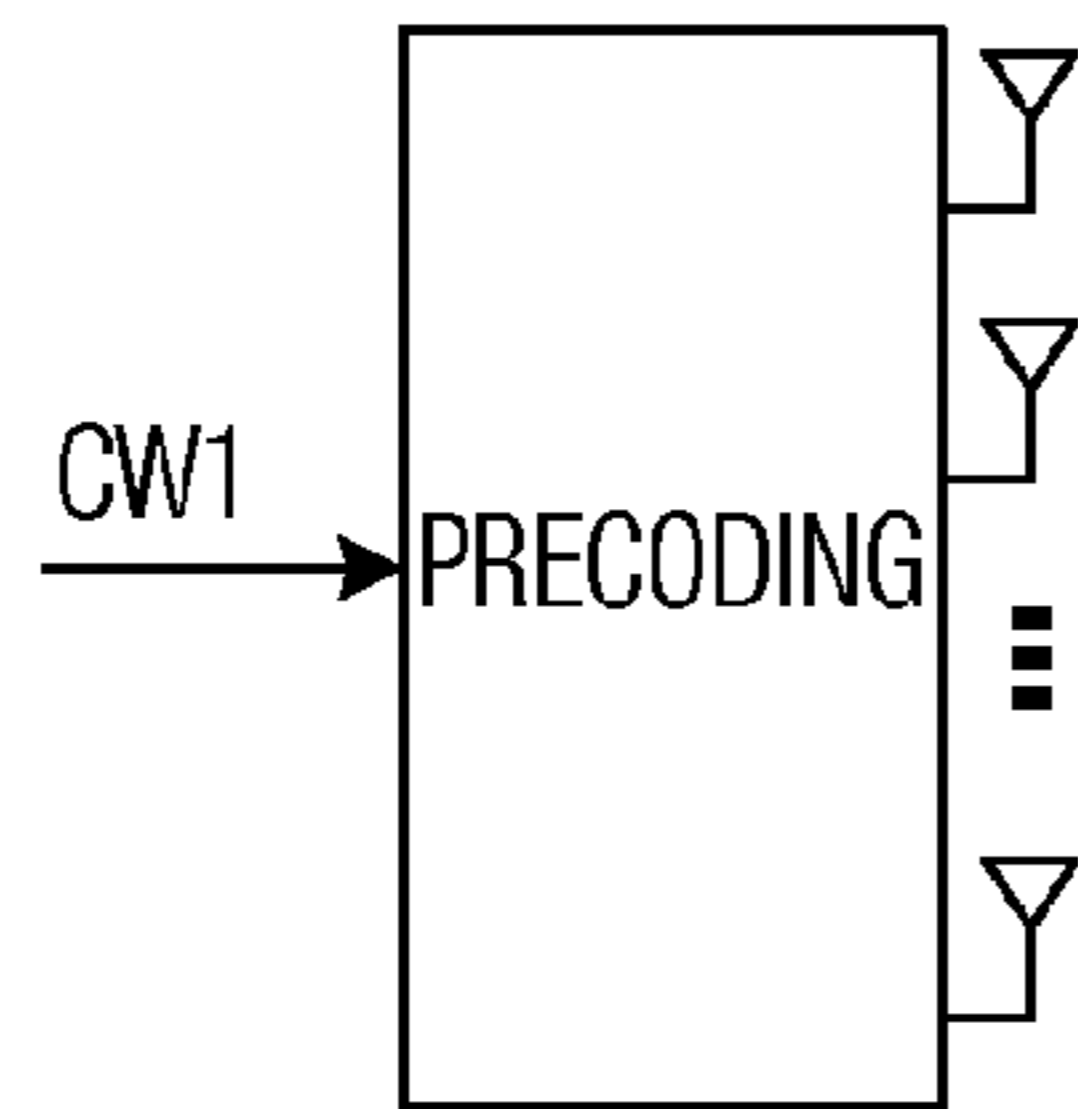

Fig. 4a

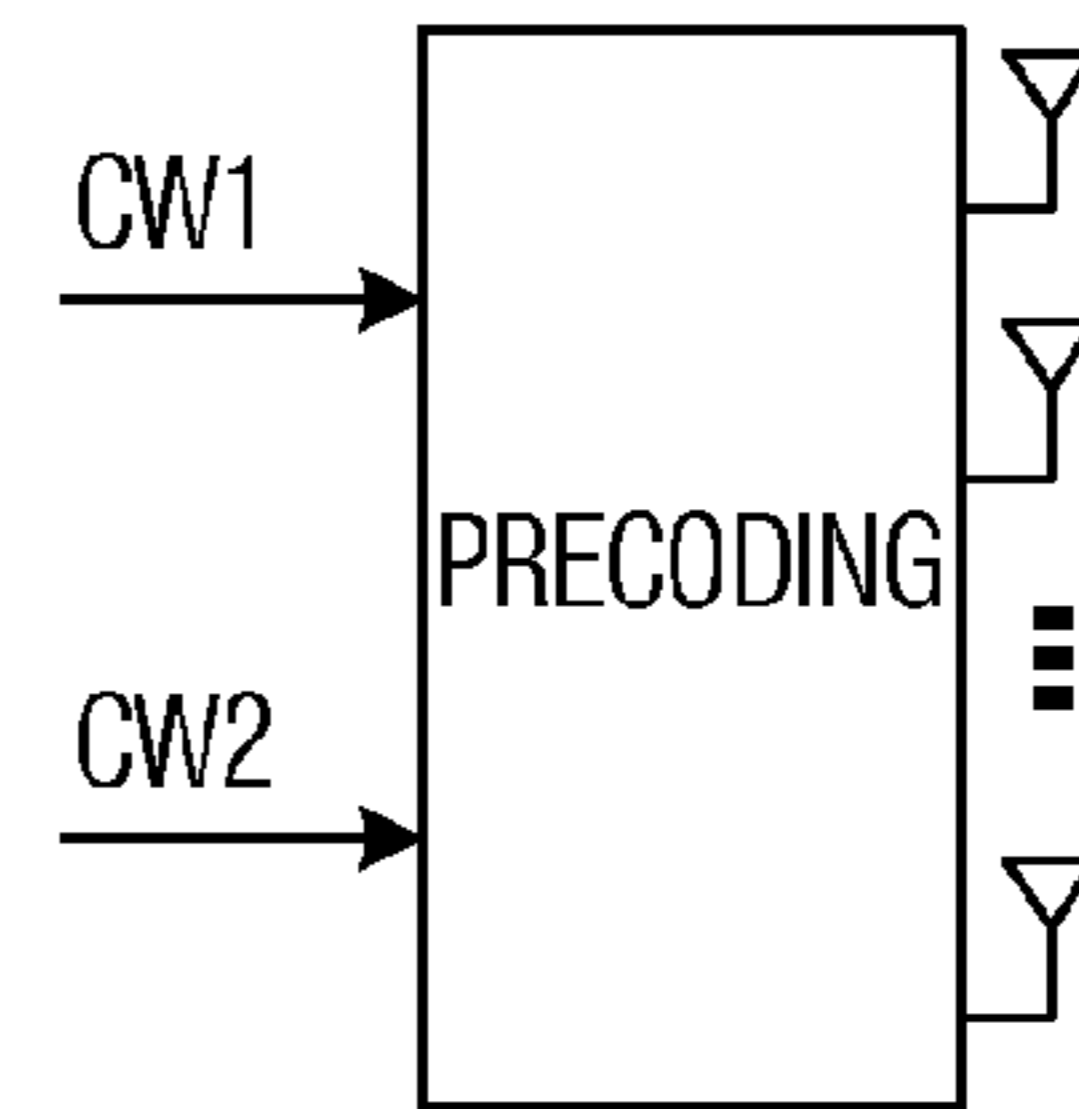

Fig. 4b

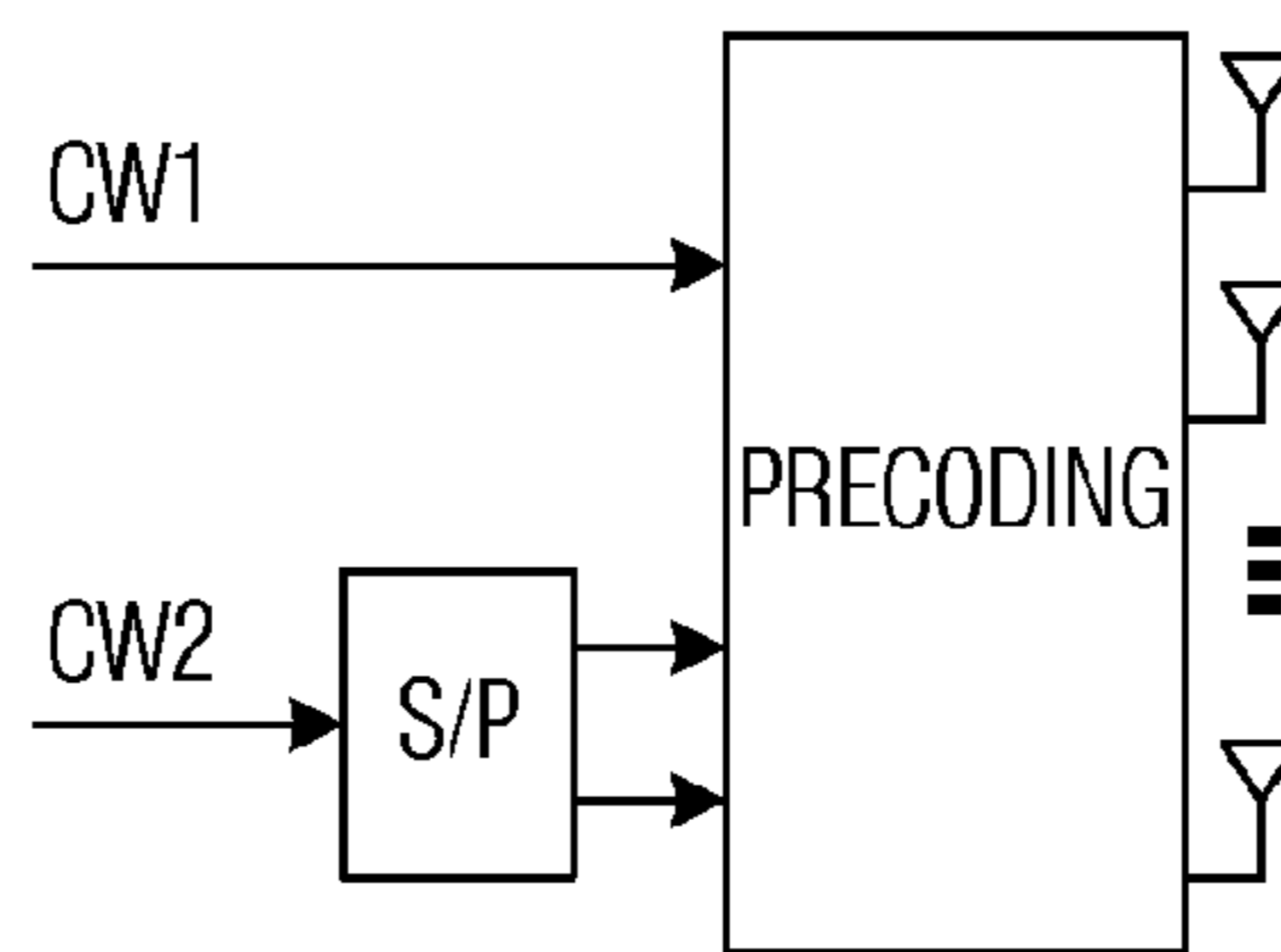

Fig. 4c

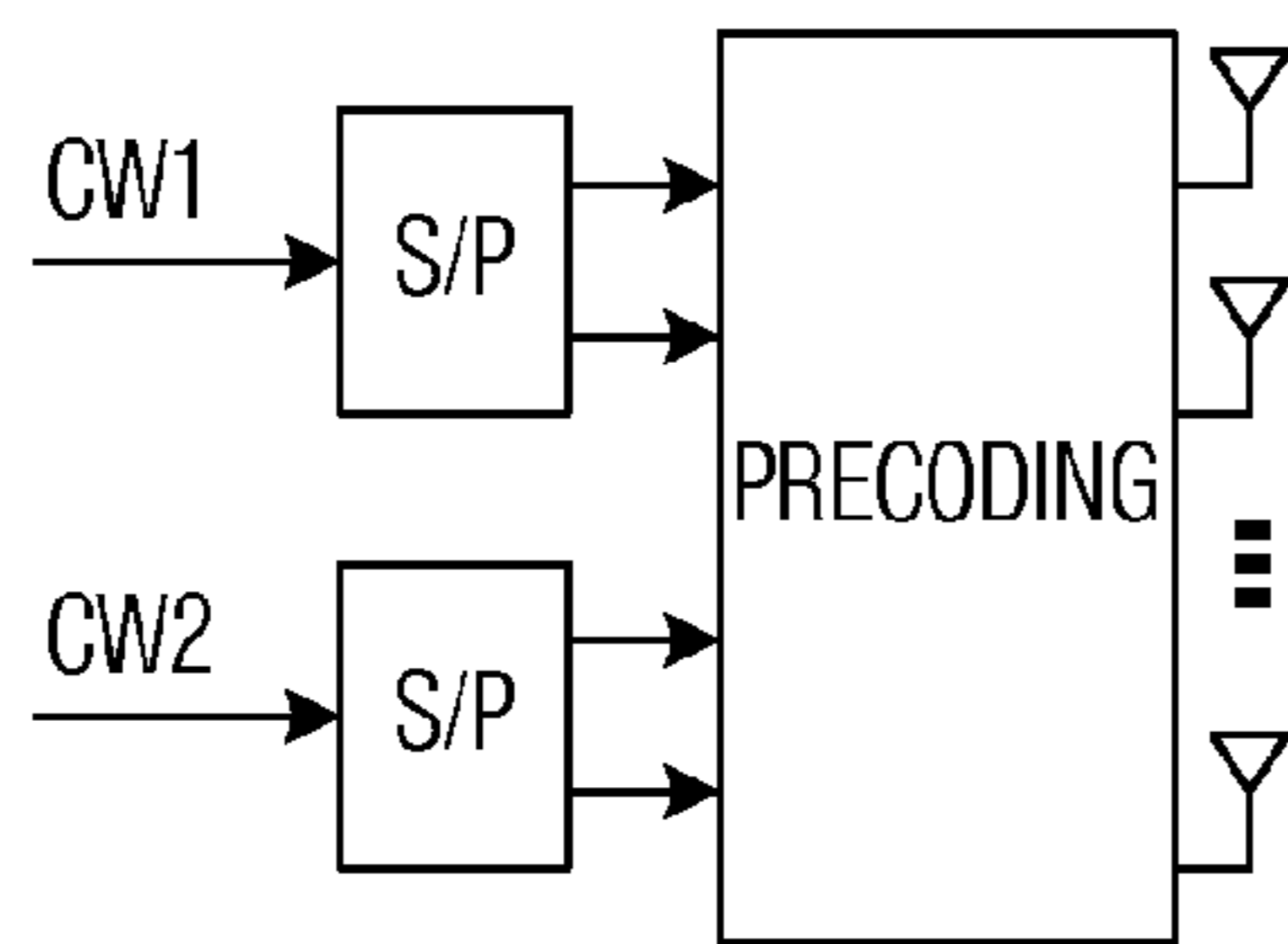

Fig. 4d

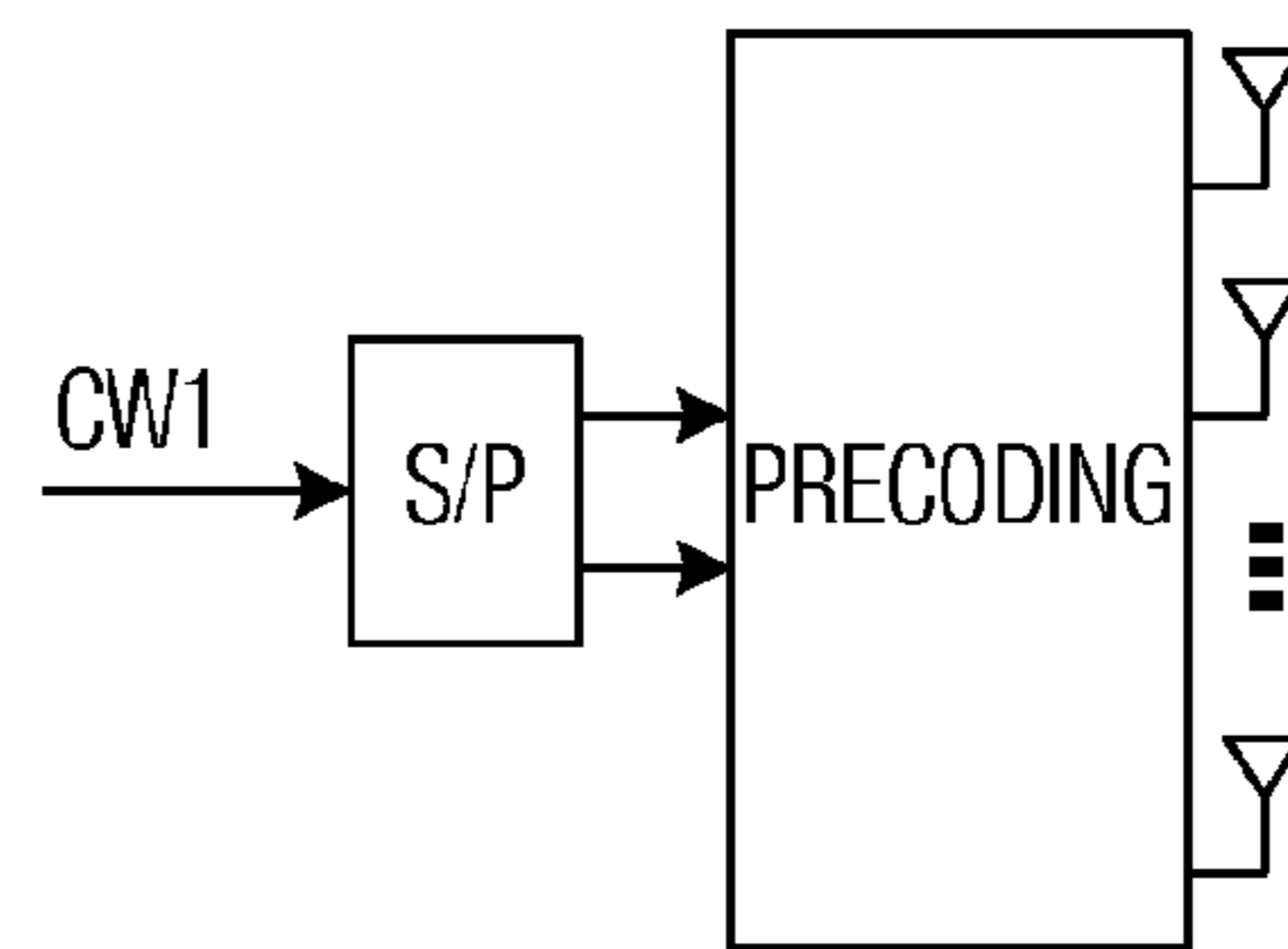

Fig. 4e

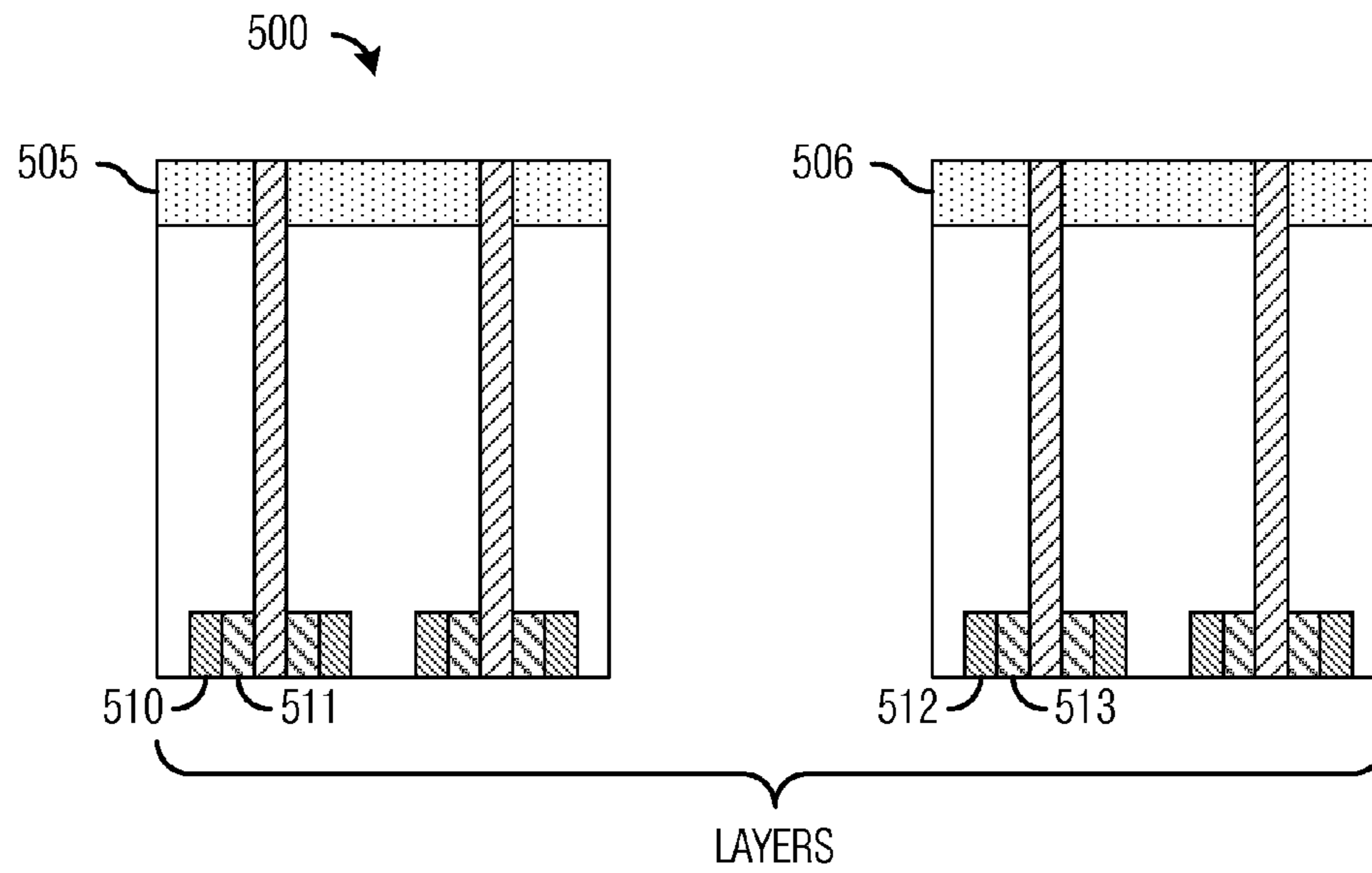

Fig. 5

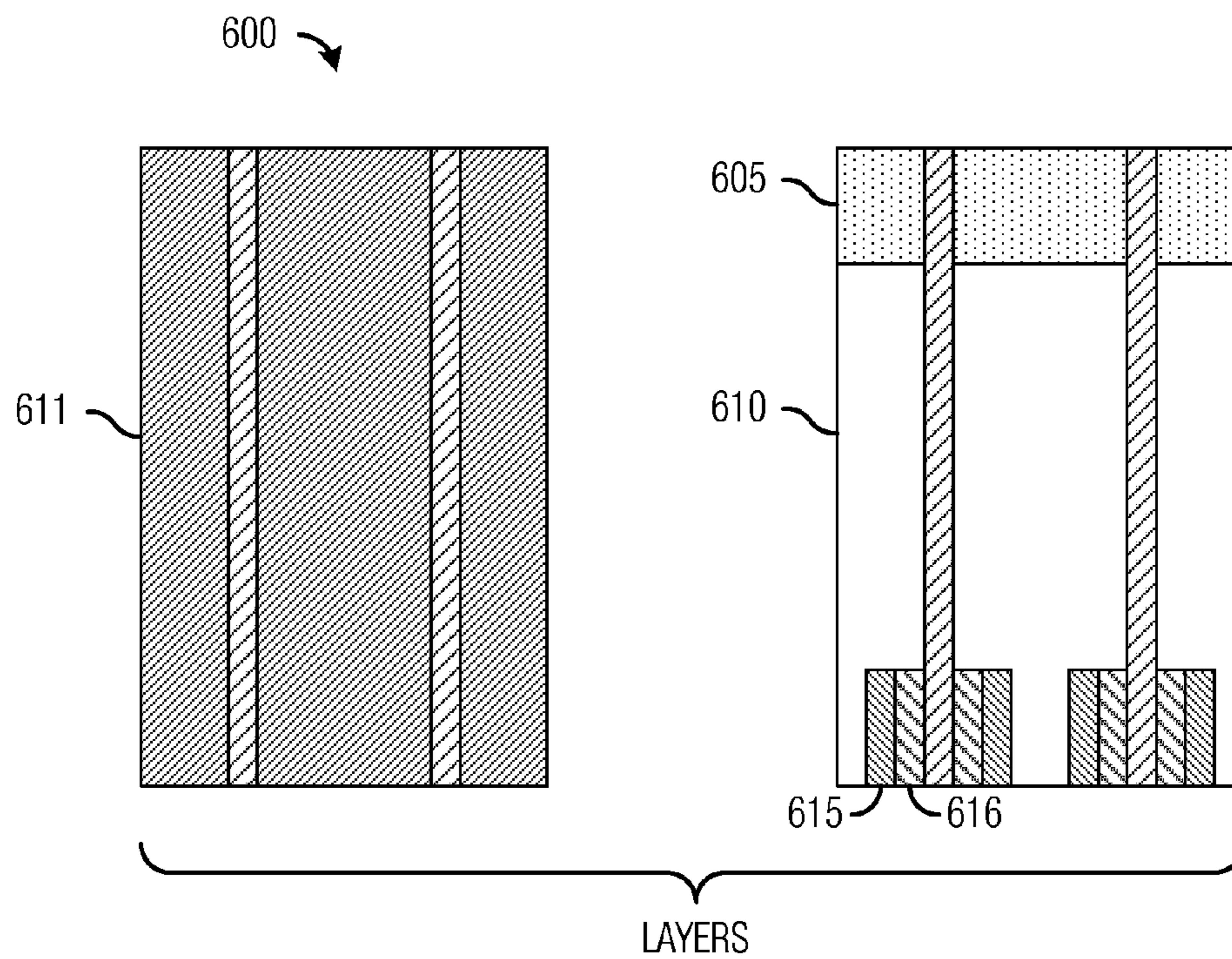

Fig. 6

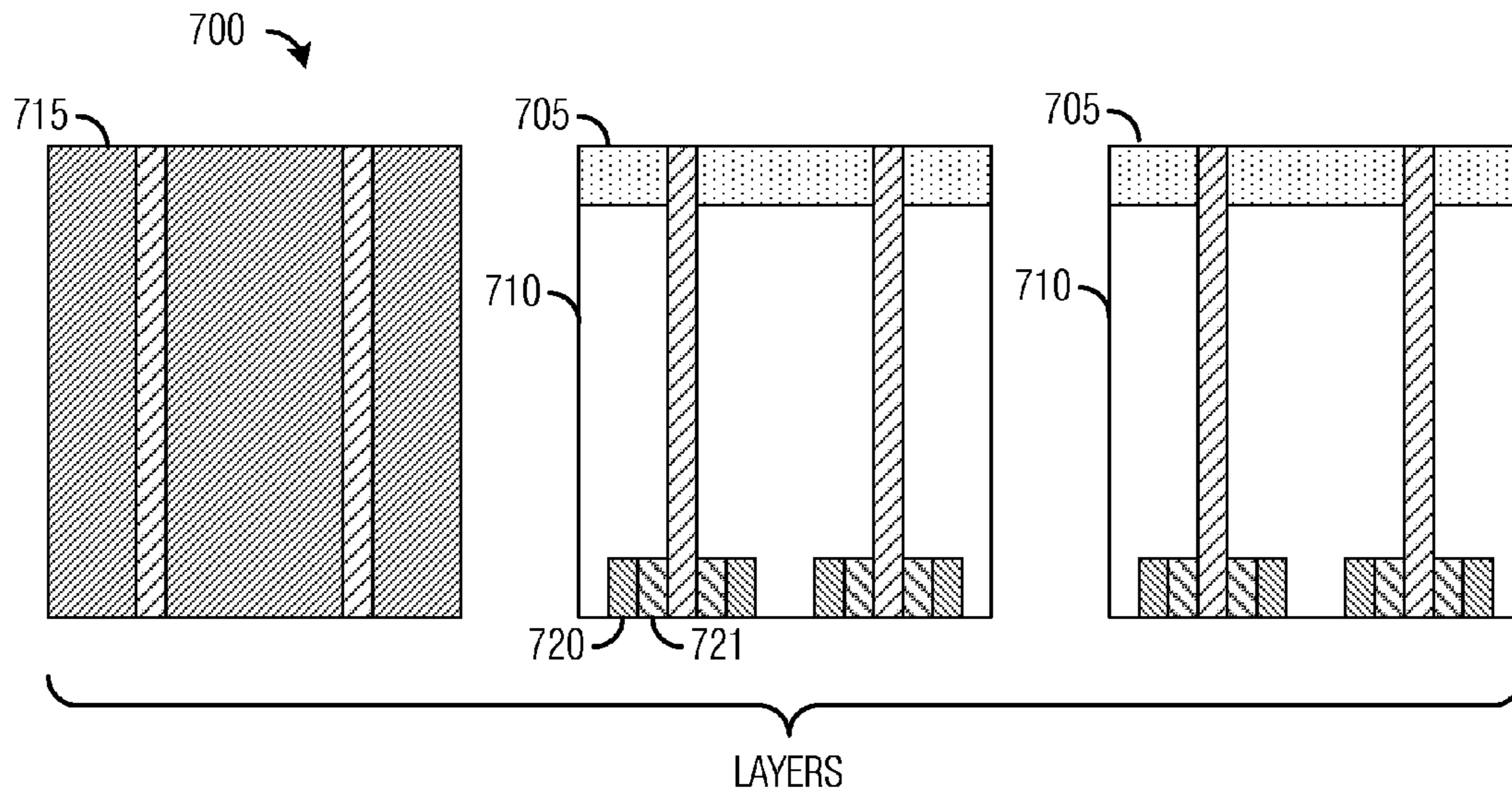

Fig. 7

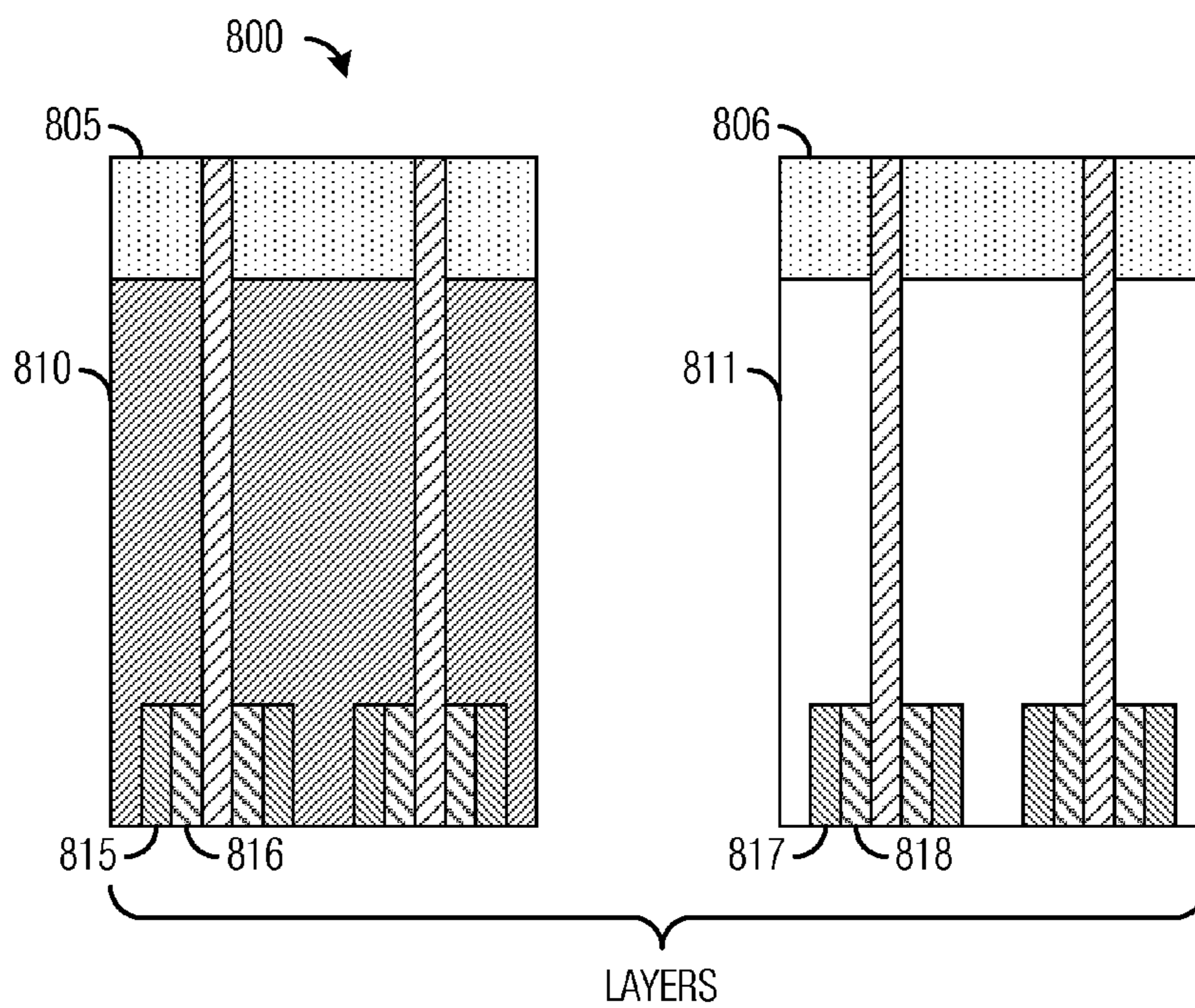

Fig. 8

1

**SYSTEM AND METHOD FOR
MULTIPLEXING CONTROL AND DATA
CHANNELS IN A MULTIPLE INPUT,
MULTIPLE OUTPUT COMMUNICATIONS
SYSTEM**

This application claims the benefit of U.S. Provisional Patent Application Ser. No. 61/293,985, filed on Jan. 11, 2010, and entitled "System and Method for Multiplexing Control and Data Channels in a Multiple Input, Multiple Output Communications System," which application is incorporated herein by reference.

TECHNICAL FIELD

The present invention relates generally to wireless communications, and more particularly to a system and method for multiplexing control and data channels in a multiple input, multiple output (MIMO) communications system.

BACKGROUND

For 3GPP Rel-8 (commonly referred to as Long Term Evolution (LTE)), broadly speaking, uplink control information may be sent in two ways: (a) without simultaneous transmission of data (i.e., uplink shared channel (UL-SCH)); and (b) with simultaneous transmission of UL-SCH. Here we are concerned with (b) where control and data are sent on the same subframe.

When user equipment (UE) has a valid scheduling grant, network resources are assigned for the UL-SCH in a corresponding subframe. In the subframe, the uplink layer 1 (L1)/layer 2 (L2) control signaling may be multiplexed with the coded UL-SCH onto a physical uplink shared channel (PUSCH) prior to modulation and discrete Fourier transform (DFT) transform precoding. The control signaling may include hybrid automatic repeat request (HARQ) acknowledgements and channel status reports.

SUMMARY OF THE INVENTION

These and other problems are generally solved or circumvented, and technical advantages are generally achieved, by embodiments of a system and method for multiplexing control and data channels in a multiple input, multiple output (MIMO) communications system.

In accordance with an embodiment, a method for transmitting control symbols and data symbols on multiple input, multiple output (MIMO) layers is provided. The method includes selecting a first set of codewords from N_{cw} codewords, distributing control symbols onto the first set of layers, placing data symbols of the first set of codewords onto the first set of layers, placing data symbols of the $(N_{cw} - N_{cw1})$ remaining codewords to remaining layers if $N_{cw} > N_{cw1}$, and transmitting the multiple MIMO layers. The first set of codewords is associated with a first set of layers from the multiple MIMO layers, and the N_{cw} codewords are to be transmitted simultaneously and the first set of codewords comprises N_{cw1} MIMO codewords, where N_{cw} and N_{cw1} are integers greater than or equal to 1. The remaining layers are MIMO layers from the multiple MIMO layers not in the first set of layers.

In accordance with an embodiment, a method for transmitting control symbols and data symbols on multiple input, multiple output (MIMO) layers is provided. The method includes constructing one or more codewords to be simultaneously transmitted over a plurality of MIMO layers, distributing control symbols over the plurality of MIMO layers,

2

placing data symbols of the one or more codewords onto the plurality of MIMO layers, and transmitting the multiple MIMO layers.

In accordance with an embodiment, a method for transmitting control symbols and data symbols on multiple input, multiple output (MIMO) layers is provided. The method includes selecting a codeword from a plurality of codewords, distributing control symbols onto the subset of MIMO layers, placing data symbols of the plurality of codewords onto the plurality of layers, and transmitting the multiple MIMO layers. The plurality of codewords are to be transmitted over a plurality of MIMO layers, and the selected codeword is to be transmitted over a subset of MIMO layers of the plurality of MIMO layers.

An advantage of an embodiment is that control signals multiplexed onto multiple MIMO layers may help with diversity processing gain.

Yet another advantage of an embodiment is that multiplexing the control signals onto multiple MIMO layers based on the type, requirements, and nature of the control information is transmitted. For example, CQI/PMI control signals may be mapped onto different MIMO layers or CWs or number of MIMO layers than HARQ ACK/NACK or RI.

The foregoing has outlined rather broadly the features and technical advantages of the present invention in order that the detailed description of the embodiments that follow may be better understood. Additional features and advantages of the embodiments will be described hereinafter which form the subject of the claims of the invention. It should be appreciated by those skilled in the art that the conception and specific embodiments disclosed may be readily utilized as a basis for modifying or designing other structures or processes for carrying out the same purposes of the present invention. It should also be realized by those skilled in the art that such equivalent constructions do not depart from the spirit and scope of the invention as set forth in the appended claims.

BRIEF DESCRIPTION OF THE DRAWINGS

For a more complete understanding of the embodiments, and the advantages thereof, reference is now made to the following descriptions taken in conjunction with the accompanying drawings, in which:

FIG. 1 is a space diagram of a multiplexing of control and data in LTE;

FIG. 2 is a diagram of a transmitter structure of rank-2 UL transmission using two TBs for two transmit antennas in the case of no ACK/NACK spatial bundling without layer shifting;

FIG. 3 is a diagram of a transmitter structure of rank-2 UL transmission using two TBs for two transmit antennas in the case of ACK/NACK spatial bundling with layer shifting;

FIG. 4a is a diagram of a single codeword to a single layer mapping in LTE;

FIG. 4b is a diagram of a mapping of two codewords to two layers;

FIG. 4c is a diagram of a mapping of two codewords to three layers;

FIG. 4d is a diagram of a mapping of two codewords to four layers;

FIG. 4e is a diagram of a mapping of one codeword to two layers;

FIG. 5 is a space diagram of two MIMO layers containing control and data from a single codeword;

FIG. 6 is a space diagram of two MIMO layers containing control and data from two codewords;

3

FIG. 7 is a space diagram of three MIMO layers containing control and data from two codewords; and

FIG. 8 is a space diagram of two MIMO layers containing control and data from two codewords.

DETAILED DESCRIPTION OF ILLUSTRATIVE EMBODIMENTS

The making and using of the embodiments are discussed in detail below. It should be appreciated, however, that the present invention provides many applicable inventive concepts that can be embodied in a wide variety of specific contexts. The specific embodiments discussed are merely illustrative of specific ways to make and use the invention, and do not limit the scope of the invention.

FIG. 1 illustrates space diagram 100 of a multiplexing of control and data in LTE. As shown in FIG. 1, control and data are multiplexed onto a single uplink layer. Space diagram 100 may be partitioned into different zones with the zones carrying different information. Zones hashed with a similar hashing pattern carry similar information. For example, zone 105 may be used to carry a reference signal, e.g., a pilot. While zone 110 may be used to carry UL-SCH data, zone 115 may be used to carry channel quality indicator and/or precoding matrix indication information, zone 120 may be used to carry ACKs/NACKs used in HARQ, and zone 125 may be used to carry rank indicator information.

Each zone may contain a plurality of resource elements (REs) with an exact number of resource elements assigned to an individual zone being dependent on factors such as coding and modulation scheme being used, communications system configuration, number of UE operating, and so forth. The proportions of the various zones shown in space diagram 100 are not intended to illustrate precise relationships of the amount of resource elements allocated to the various zones, but to convey a relative relationship and arrangement of the zones.

For 3GPP Rel-10 (commonly referred to as LTE-Advanced (LTE-A)), a transmission block (TB) may be mapped to a MIMO codeword (CW) after a chain of processing including channel coding, rate matching, modulation, and so on, the same as in LTE. However, the maximum number of MIMO layers in LTE-A uplink is increased to four and the maximum number of MIMO codewords is increased to two.

In contrast to downlink MIMO, uplink (UL) MIMO of LTE-A is considering adopting layer shifting together with ACK/NACK spatial bundling in the processing chain. FIG. 2 illustrates a transmitter structure 200 of rank-2 UL transmission using two TBs for two transmit antennas in the case of no ACK/NACK spatial bundling without layer shifting. FIG. 3 illustrates a transmitter structure 300 of rank-2 UL transmission using two TBs for two transmit antennas in the case of ACK/NACK spatial bundling with layer shifting.

FIG. 4a illustrates a single codeword to a single layer mapping in LTE. FIG. 4b illustrates a mapping of two codewords to two layers. FIG. 4c illustrates a mapping of two codewords to three layers. FIG. 4d illustrates a mapping of two codewords to four layers. FIG. 4e illustrates a mapping of one codeword to two layers. If the design used in DL LTE is used, then the mapping shown in FIG. 4e may only be used for retransmissions where an initial transmission used two layers to send the TB. Further, the combinations of codeword (CW) to layer mapping shown in FIG. 4a through FIG. 4e can be used for LTE-Advanced uplink.

As stated in TR36.814, “simultaneous transmission of uplink L1/L2 control signaling and data is supported through two mechanisms:

4

Control signaling is multiplexed with data on PUSCH according to the same principle as in Rel-8

Control signaling is transmitted on physical uplink control channel (PUCCH) simultaneously with data on PUSCH.”

Although control may be transmitted on PUCCH simultaneously with data on PUSCH, control signaling multiplexing with data on PUSCH is still needed for at least the following cases:

Multiplexing data and control on PUSCH reduces CM and hence increases the coverage.

When CQI/PMI/RI and maybe other channel state information is triggered by PDCCH that assigns UL-SCH transmission, such control information has to be multiplexed together with data on PUSCH.

When only one MIMO layer is being used, the same control-data multiplexing scheme as described for 3GPP Release-8 should be used (shown in FIG. 1). New designs of control-data multiplexing are discussed below for cases with multiple MIMO layers, e.g., one or more codewords mapped to two, three, or four MIMO layers (shown in FIGS. 4b through 4e).

The multiplexing of control-data to multiple MIMO layer PUSCH transmission may take several approaches: single codeword or all codewords.

Single codeword rule—Select layers associated with one of the codewords for control-data multiplexing. A criteria or rule may be needed to select an appropriate codeword. The codeword may be selected explicitly (for example, select a first codeword) via higher layer signaling or dynamic physical downlink control channel (PDCCH) signaling. Alternatively, the codeword may be selected implicitly using a) a codeword’s modulation and coding scheme (MCS) level as provided in the PDCCH that assigns the PUSCH, b) a codeword’s signal plus interference to noise ratio (SINR), c) a number of layers occupied by a codeword, d) an impact of a codeword on PUSCH performance, e) HARQ transmission status, for example, initial versus re-transmissions or a combination thereof.

All codewords rule—Use all the MIMO layers for control-data multiplexing. When one codeword is mapped to two layers, the single codeword strategy degenerates to the all codewords strategy.

The performance comparison and selection for a final solution depends heavily on whether ACK/NACK spatial bundling (LS/ANB) with layer shifting is used for UL MIMO transmissions. Further considerations may include the type of receiver (successive interference cancellation (SIC) versus minimum mean-square error (MMSE)) that an enhanced NodeB (eNB) is likely to implement, whether re-transmission is on one of the codewords in case of no LS/ANB, size (number of bits) of the control information (relative to that of the PUSCH resource allocated). In addition, different consideration may be needed for CQI/PMI versus ACK/NACK and RI for diversity and coverage purposes. For example, CQI/PMI may be mapped to different layers or CWs, or a different number of layers or CWs, than the ACK/NACK or RI.

Although LTE control information, such as ACK/NACK, RI, CQI/PMI, is discussed herein, other control signaling, such as carrier indicators, may be processed in a similar manner in LTE-A.

Control Information on a Single Codeword.

Since control information is important for the proper functioning of a communications system, they need to be protected as much as possible to that they may be received by the eNB correctly. Furthermore, the control information is relatively small and is protected by relatively weak codes, such as

5

block codes and convolutional codes, thus a physical channel with better quality should be used to carry the control information.

Therefore, if there are multiple MIMO layers, design considerations may include:

The control information should be mapped to layers with better quality. For example, for two codewords mapped to two layers, assuming that layer two is better than layer one, then the control information should be mapped to layer two, leaving layer one completely for data only.

It may be simpler for the receiver if the control information is mapped to layers belonging to a same codeword.

If the control information is to be multiplexed with a codeword X, the control information should be mapped to all layers of codeword X. Doing so allows the control information to take advantage of diversity between layers.

If the control information is mapped to multiple layers, it should occupy the same resource elements across the multiple layers.

Thus for the codeword-to-layer mapping scenarios shown in FIGS. 4a through 4e, the control-data multiplexing is as follows. In the figures to be discussed below, the illustrated locations of the control signals, e.g., FIGS. 1, 5-8, the amount of resource elements allocated for each type of control signaling is for illustration only. As in LTE, the number of modulation symbols for each type of control signaling will be calculated as a function of several variables. Then a rule may be used to assign the modulation symbols to the resource elements till all the modulation symbols are exhausted. The number of modulation symbols allocated in each layer/slot may vary.

One codeword mapped to one layer: Reuse 3GPP Release-8 design (FIG. 1).

One codeword mapped to two layers: FIG. 5 illustrates a space diagram 500 of two MIMO layers containing control and data from a single codeword. Control information (contained in zone 505 and zone 506 as well as zones 510-513) may be multiplexed onto both layers, wherein control modulation symbols occupy the same (or approximately the same) resource elements in both layers. As illustrated in FIG. 5, the information carried over zones, such as zones 510-513, may be time-division multiplexed with the data. As specified in LTE Rel-8, zones 510-513 may also be used to carry HARQ ACK/NACK information and rank indicator (RI).

Two codewords mapped to two layers: FIG. 6 illustrates a space diagram 600 of two MIMO layers containing control and data from two codewords. Map control information to a layer according to single codeword rule as discussed previously (zone 605 and zones 615 and 616). Let the layer carrying the control information be referred to as layer X. Within layer X, the multiplexing of control and data reuses the 3GPP Release-8 design. Here the control information includes not only CQI, ACK/NACK, RI used in Release-8, but it also includes any new type of control information that may be defined for Release-10 or later, e.g., indicator for carrier aggregation and COMP, etc. Zone 610 carries data from codeword with control and data, while zone 611 carries data from codeword with only data.

Two codewords mapped to three layers: FIG. 7 illustrates a space diagram 700 of three MIMO layers containing control and data from two codewords. As shown in FIG. 7, a first codeword (let it be referred to as CW1) is mapped to one layer and a second codeword (let it be referred to as CW2) is mapped to two layers. Clearly, CW2 contains twice as many modulation symbols as CW1 if control information is excluded. Thus, if control information is punctured into the data modulation symbols, multiplexing control symbols with

6

CW2 may be better than multiplexing with CW1 in terms of a number of data modulation symbols being punctured from a codeword. Zone 705 and zones 720 and 721 contain control information from codeword containing control and data, zone 710 contains data from codeword containing control and data, and zone 715 contains data from codeword containing only data.

Two codewords mapped to four layers: Each codeword is mapped to two MIMO layers. Let a first codeword where control information resides be denoted codeword X. Codeword X is selected according to single codeword rule as discussed previously. Within codeword X, multiplexing of control and data may be performed as with codeword CW2 in the case with two codewords mapped to three layers.

Control Information on all Codewords.

In the situation where control information is contained in all codewords, then the control information may be always mapped to all MIMO layers. As discussed herein, all codewords means that there are two or more codewords. Therefore, situations where one codeword is mapped to one or two layers may not be considered. FIG. 8 illustrates a space diagram 800 of two MIMO layers containing control and data from two codewords. As shown in FIG. 8, control information may be mapped to both layers, while data from each of the two codewords are mapped to a single layer. The mapping of control and data from two codewords to two MIMO layers as shown in FIG. 8 may have an advantage of maximizing spatial diversity for the control information as well as better coverage of control information. Zones 805 and 806 as well as zones 815 through 818 carry control information from both codewords, while zone 810 carries data from a first codeword and zone 811 carries data from a second codeword.

However, resource assignment of control signaling may be difficult due to separate processing of two transmission blocks. For example, two transmission blocks may have different modulation orders, thereby causing control information to use two different modulation orders. If a SIC receiver is used, mapping control information to all layers may make it difficult to implement the cancellation. Additionally, if ACK/NACK spatial bundling with layer shifting is adopted, full or close to full spatial diversity may be available to each layer, making all codeword mapping even more unattractive.

In 3GPP Release-8, formulas for determining a number of coded symbols for HARQ-ACK or rank indicator and channel quality information are:

$$Q' = \min \left(\left\lceil \frac{O \cdot M_{sc}^{PUSCH-initial} \cdot N_{symbol}^{PUSCH-initial} \cdot \beta_{offset}^{PUSCH}}{\sum_{r=0}^{C-1} K_r} \right\rceil, 4 \cdot M_{sc}^{PUSCH} \right)$$

and

$$Q' = \min \left(\left\lceil \frac{(O+L) \cdot M_{sc}^{PUSCH-initial} \cdot N_{symbol}^{PUSCH-initial} \cdot \beta_{offset}^{PUSCH}}{\sum_{r=0}^{C-1} K_r} \right\rceil, M_{sc}^{PUSCH} \cdot N_{symbol}^{PUSCH} - \frac{Q_{RI}}{Q_m} \right)$$

To extend to multiple layer PUSCH transmissions, the formulas need to be updated as well. Note that while ACK/NACK, RI, and CQI are used as examples of control information, similar formula may be used to carry other types of control information, e.g., the indicator for carrier aggregation and COMP, etc. The formulas are not to be interpreted to be

limited to any specific control information type. Formulas for the single codeword case are shown below.

ACK/NACK (RI) for single codeword:

$$Q' = \min \left(\left[\frac{O \cdot M_{sc}^{PUSCH-initial} \cdot N_{symp}^{PUSCH-initial} \cdot N_{layer} \cdot \beta_{offset}^{PUSCH}}{\sum_{r=0}^{C-1} K_r} \right], \left[4 \cdot M_{sc}^{PUSCH} \cdot N_{layer} \right] \right),$$

where N_{layer} is the number of layers for the multiplexing CW. In addition, the order of mapping REs across layers need to be defined.

CQI for single codeword:

$$Q' = \min \left(\left[\frac{(O+L) \cdot M_{sc}^{PUSCH-initial} \cdot N_{symp}^{PUSCH-initial} \cdot N_{layer} \cdot \beta_{offset}^{PUSCH}}{\sum_{r=0}^{C-1} K_r} \right], \left[M_{sc}^{PUSCH} \cdot N_{symp}^{PUSCH} \cdot N_{layer} - \frac{Q_{RI}}{Q_m} \right] \right).$$

In addition, an order of mapping resource elements across layers need to be defined.

Formulas for the all codeword case are shown below.

ACK/NACK for all codewords:

$$Q' = \min \left(\left[\frac{O \cdot (N_{layer,1} + N_{layer,2})}{N_{layer,1} \cdot \frac{MPR_1}{\beta_1} + N_{layer,2} \cdot \frac{MPR_2}{\beta_2}} \right], \left[4 \cdot M_{sc}^{PUSCH} \cdot (N_{layer,1} + N_{layer,2}) \right] \right) \\ = \min \left(\left[\frac{O \cdot M_{sc}^{PUSCH-initial} \cdot N_{symp}^{PUSCH-initial} \cdot (N_{layer,1} + N_{layer,2})}{\frac{\sum_{r=0}^{C_1-1} K_{r,1}}{\beta_1} + \frac{\sum_{r=0}^{C_2-1} K_{r,2}}{\beta_2}} \right], \left[4 \cdot M_{sc}^{PUSCH} \cdot (N_{layer,1} + N_{layer,2}) \right] \right)$$

-continued

$$= \min \left(\left[\frac{O \cdot M_{sc}^{PUSCH-initial} \cdot N_{symp}^{PUSCH-initial} \cdot (N_{layer,1} + N_{layer,2}) \cdot \beta_{offset}^{PUSCH}}{\sum_{r=0}^{C_1-1} K_{r,1} + \sum_{r=0}^{C_2-1} K_{r,2}} \right], \left[4 \cdot M_{sc}^{PUSCH} \cdot (N_{layer,1} + N_{layer,2}) \right] \right)$$

The last step shown above assumes that the two codewords use the same offset value (β). MPR_n ($n=1, 2$) is the spectral efficiency associated to the MCS level of codeword n . To derive this formula, a weighted (by number of layers of each codeword) average MPR may be used to calculate the number coded symbols for the control information while the original formula of LTE Release-8 uses the MPR of a single codeword. In addition, an order of mapping resource elements across layers and codewords need to be defined. In order to achieve diversity gain, the mapping may be first made across codewords/layers. In the case that different modulation levels are used in the two codewords, coding scheme of ACK/NACK and RI need to be modified.

CQI for all codewords:

$$Q' = \min \left(\left[\frac{(O+L) \cdot M_{sc}^{PUSCH-initial} \cdot N_{symp}^{PUSCH-initial} \cdot (N_{layer,1} + N_{layer,2}) \cdot \beta_{offset}^{PUSCH}}{\sum_{r=0}^{C_1-1} K_{r,1} + \sum_{r=0}^{C_2-1} K_{r,2}} \right], \left[M_{sc}^{PUSCH} \cdot N_{symp}^{PUSCH} \cdot (N_{layer,1} + N_{layer,2}) - Q'_{RI} \right] \right)$$

In addition, the order of mapping resource elements across layers and codewords need to be defined. In order to achieve diversity gain, the mapping may be first made across codewords/layers. In the case that different modulation levels are used in the two codewords, performance need to be verified. Furthermore, rank dependent offset values may be considered for all cases where different values of the offset β may be configured for different number of layers of PUSCH transmission.

Comparison of Options.

In Table 1, the pros and cons of single codeword and all codeword mapping options are compared considering a variety of combinations. The comparison shows that single codeword options may be a simpler solution than the all codeword options.

TABLE 1

Comparison of Single-CW strategy with All-CW strategy under assumption of (a) layer shifting vs no layer shifting and (b) MMSE receiver vs SIC receiver.

		LS with ANB	No LS and ANB
MMSE receiver	Single-CW	Due to ANB, balancing the FER performance of the 2 CWs need to be considered.	Need to select a CW for multiplexing.
	All-CWs	Same/similar MCS level is likely for both CWs. Due to ANB, balancing the FER performance of the 2 CWs should be easy for this setting.	Different MCS levels are likely for the 2 CWs which make it difficult to determine the number of coded symbols for the control information.
SIC receiver	Single-CW	Selecting CW for multiplexing could be tricky. Due to ANB, balancing the FER performance of the 2 CWs need to be considered.	Selecting CW for multiplexing could be tricky.
	All-CWs	Different MCS levels may be used for the 2 CWs which make it difficult to determine the number of coded symbols for the control information. In addition, multiplexing control in both CWs may interrupt the SIC receiver behavior. Due	Different MCS levels are likely for the 2 CWs which make it difficult to determine the number of coded symbols for the control information. In addition, multiplexing control in both

TABLE 1-continued

Comparison of Single-CW strategy with All-CW strategy under assumption of (a) layer shifting vs no layer shifting and (b) MMSE receiver vs SIC receiver.	
LS with ANB	No LS and ANB
to ANB, balancing the FER performance of the 2 CWs need to be considered.	CWs may interrupt the SIC receiver behavior.

Advantageous features of embodiments of the invention may include: a method for transmitting control symbols and data symbols on multiple MIMO layers, the method comprising: selecting a first set of codewords associated with a first set of layers from the multiple MIMO layers from N_{cw} codewords, wherein the N_{cw} codewords are to be transmitted simultaneously and the first set of codewords comprises N_{cw1} MIMO codewords, where N_{cw1} is an integer greater than or equal to 1; distributing control symbols onto the first set of layers; placing data symbols of the first set of codewords onto the first set of layers; placing data symbols of the $(N_{cw}-N_{cw1})$ remaining codewords to remaining layers if $N_{cw}>N_{cw1}$; and transmitting the multiple MIMO layers. The method could further include, wherein the first set of codewords comprises a single codeword. The method could further include, wherein the first set of codewords is selected by a communications device. The method could further include, wherein the first set of codewords is selected based on channel quality. The method could further include, wherein the first set of codewords is selected based on a modulating and coding scheme (MCS) level associated with the codewords. The method could further include, wherein the first set of codewords is selected based on the number of layers associated with the codewords. The method could further include, wherein the first set of codewords is selected based on a level of impact the control symbols have on the performance of the data transmission of each codeword. The method could further include, wherein the impact is a proportion of control symbols to data symbols for each codeword. The method could further include, wherein the first set of codewords is selected based on a hybrid automatic repeat request (HARQ) transmission status associated with the codewords. The method could further include, wherein the first set of codewords is selected by a controller serving a communications device. The method could further include, wherein the first set of codewords is signaled to the communications device via a downlink message. The method could further include, wherein the first set of codewords comprises N_{cw} codewords. The method could further include, wherein distributing control symbols onto the first set of layers is based on the MCS levels of the first set of codewords. The method could further include, wherein distributing control symbols onto the first set of layers is based on a weighted MCS levels of the first set of codewords. The method could further include, wherein distributing control symbols onto the first set of layers comprises distributing control symbols substantially equally onto the first set of layers. The method could further include, wherein selecting a first set of codewords comprises selecting two different first set of codewords for two different types of control symbols.

Although the embodiments and their advantages have been described in detail, it should be understood that various changes, substitutions and alterations can be made herein without departing from the spirit and scope of the invention as defined by the appended claims. Moreover, the scope of the present application is not intended to be limited to the particular embodiments of the process, machine, manufacture,

composition of matter, means, methods and steps described in the specification. As one of ordinary skill in the art will readily appreciate from the disclosure of the present invention, processes, machines, manufacture, compositions of matter, means, methods, or steps, presently existing or later to be developed, that perform substantially the same function or achieve substantially the same result as the corresponding embodiments described herein may be utilized according to the present invention. Accordingly, the appended claims are intended to include within their scope such processes, machines, manufacture, compositions of matter, means, methods, or steps.

What is claimed is:

1. A method for transmitting control symbols and data symbols on multiple input, multiple output (MIMO) layers, the method comprising:

selecting a first set of codewords from N_{cw} codewords, wherein the first set of codewords is associated with a first set of layers from the multiple MIMO layers, and wherein the N_{cw} codewords are to be transmitted simultaneously and the first set of codewords comprises N_{cw1} MIMO codewords, where N_{cw} and N_{cw1} are integers greater than or equal to 1;

distributing control symbols onto the first set of layers, wherein a quantity of the control symbols for each of the first set of layers is determined in accordance with a variable transmission rank-dependent offset of the first set of codewords, wherein the offset is different for different transmission ranks each having a different total number of the MIMO layers;

placing data symbols of the first set of codewords onto the first set of layers;

placing data symbols of the $(N_{cw}-N_{cw1})$ remaining codewords to remaining layers if $N_{cw}>N_{cw1}$, wherein the remaining layers are MIMO layers from the multiple MIMO layers not in the first set of layers; and transmitting the multiple MIMO layers.

2. The method of claim 1, wherein the transmitting the multiple MIMO layers comprises precoding the data symbols and the control symbols with a discrete Fourier transform (DFT) transform.

3. The method of claim 1, wherein the first set of codewords comprises a single codeword.

4. The method of claim 3, wherein the control symbols comprise channel quality information (CQI), precoding matrix indicators (PMI), or a combination thereof.

5. The method of claim 3, wherein the first set of codewords is selected by a controller serving a communications device.

6. The method of claim 5, wherein the first set of codewords is signaled to the communications device via a downlink message.

7. The method of claim 5, wherein the first set of codewords is selected based on channel quality.

8. The method of claim 5, wherein the first set of codewords is selected based on a modulating and coding scheme (MCS) level associated with the codewords.

11

9. The method of claim 5, wherein the first set of codewords is selected based on the number of layers associated with the codewords.

10. The method of claim 5, wherein the first set of codewords is selected based on a level of impact the control symbols have on a performance of a data transmission of each codeword.

11. The method of claim 10, wherein the level of impact is a proportion of control symbols to data symbols for each codeword.

12. The method of claim 5, wherein the first set of codewords is selected based on a hybrid automatic repeat request (HARQ) transmission status associated with the codewords.

13. The method of claim 1, wherein the first set of codewords comprises N_{cw} codewords, where $N_{cw1}=N_{cw}$.

14. The method of claim 13, wherein the control symbols comprise hybrid automatic repeat requested (HARQ) positive acknowledgement (ACK)/negative acknowledgement (NACK) signals, rank indicator (RI) signals, or a combination thereof.

15. The method of claim 13, wherein the control symbols are time division multiplexed with the data symbols such that the control symbols are time-aligned across the multiple MIMO layers.

16. The method of claim 1, wherein a size of the control symbols distributed onto the first set of layers is based on modulating and coding scheme (MCS) levels of the first set of codewords.

17. The method of claim 16, wherein a function of the MCS levels of the first set of codewords depends on N_{cw1} , N_{cw} , or a combination thereof.

18. The method of claim 1, wherein distributing control symbols onto the first set of layers comprises distributing control symbols to substantially the same resource elements across the first set of layers.

19. The method of claim 1, wherein selecting a first set of codewords comprises selecting two different first sets of codewords for two different types of control symbols.

20. A method for transmitting control symbols and data symbols on multiple input, multiple output (MIMO) layers, the method comprising:

constructing one or more codewords to be simultaneously transmitted over a plurality of MIMO layers;

distributing control symbols over the plurality of MIMO layers, wherein a quantity of the control symbols for each of the plurality of MIMO layers is determined in accordance with a variable transmission rank-dependent offset of the one or more codewords, wherein the offset is different for different transmission ranks each having a different total number of the MIMO layers;

placing data symbols of the one or more codewords onto the plurality of MIMO layers; and

transmitting the multiple MIMO layers.

21. The method of claim 20, wherein the control symbols comprise hybrid automatic repeat requested (HARQ) positive acknowledgement (ACK)/negative acknowledgement (NACK) signals, rank indicator (RI) signals, or a combination thereof.

22. The method of claim 20, wherein the control symbols are time-aligned across each of the plurality of MIMO layers.

23. The method of claim 20, wherein the control symbols are time-division multiplexed with data symbols.

24. A method for transmitting control symbols and data symbols on multiple input, multiple output (MIMO) layers, the method comprising:

selecting a codeword from a plurality of codewords, wherein the plurality of codewords are to be transmitted

12

over a plurality of MIMO layers, and the selected codeword is to be transmitted over a subset of MIMO layers of the plurality of MIMO layers;

distributing control symbols onto the subset of MIMO layers, wherein a quantity of the control symbols for each of the subset of MIMO layers is determined in accordance with a variable transmission rank-dependent offset of the selected codeword, wherein the offset is different for different transmission ranks each having a different total number of the MIMO layers;

placing data symbols of the plurality of codewords onto the plurality of layers; and

transmitting the multiple MIMO layers.

25. The method of claim 24, wherein the control symbols comprise channel quality information (CQI) and/or precoding matrix indicators (PMI).

26. The method of claim 24, wherein the subset of MIMO layers comprises a single MIMO layer or two MIMO layers.

27. The method of claim 24, wherein the subset of MIMO layers is chosen based on channel quality, access level, or a combination thereof.

28. A method for transmitting control symbols and data symbols on multiple input, multiple output (MIMO) layers, the method comprising:

identifying a type of the control symbols;

selecting a first set of codewords according to the type of the control symbols; and

multiplexing the control symbols with data on the first set of codewords, wherein a quantity of the control symbols for each of the MIMO layers is determined in accordance with a variable transmission rank-dependent offset of the first set of codewords, wherein the offset is different for different transmission ranks each having a different total number of the MIMO layers.

29. The method of claim 28, wherein the control symbols comprise hybrid automatic repeat requested (HARQ) positive acknowledgement (ACK)/negative acknowledgement (NACK) signals, rank indicator (RI) signals, or a combination thereof.

30. The method of claim 29, wherein the first set of codewords comprises two or more codewords.

31. The method of claim 28, wherein the control symbols comprise channel quality information (CQI), precoding matrix indicators (PMI), or a combination thereof.

32. The method of claim 31, wherein the first set of codewords comprises a single codeword.

33. The method of claim 32, wherein the first set of codewords is selected based on a modulating and coding scheme (MCS) level associated with the codewords.

34. A communications device comprising:

a selecting unit configured to select a first set of codewords from N_{cw} codewords, wherein the first set of codewords is associated with a first set of layers from a plurality of multiple input, multiple output (MIMO) layers, and wherein the N_{cw} codewords are to be transmitted simultaneously and the first set of codewords comprises N_{cw1} MIMO codewords, where N_{cw} and N_{cw1} are integers greater than or equal to 1;

a distributing unit coupled to the selecting unit, the distributing unit configured to distribute control symbols onto the first set of layers, wherein a quantity of the control symbols for each of the first set of layers is determined in accordance with a variable transmission rank-dependent offset of the first set of codewords, wherein the offset is different for different transmission ranks each having a different total number of the MIMO layers;

13

a placing unit coupled to the distributing unit and to the selecting unit, the placing unit configured to place data symbols of the first set of codewords onto the first set of layers, and to place data symbols of the $(N_{cw}-N_{cw1})$ remaining codewords onto remaining layers if $N_{cw}>N_{cw1}$, wherein the remaining layers are MIMO layers from the plurality of MIMO layers not in the first set of layers; and

a transmitter coupled to the placing unit, the transmitter configured to transmit the plurality of MIMO layers.

35. The communications device of claim 34, wherein the transmitter is further configured to precode the data symbols and the control symbols with a discrete Fourier transform.

36. The communications device of claim 34, wherein the first set of codewords comprises a single codeword, and wherein the control symbols comprise channel quality information (CQI), precoding matrix indicators (PMI), or a combination thereof.

37. The communications device of claim 36, further comprising a receiver coupled to the selecting unit, the receiver configured to receive an indicator from a controller serving the communications device, the indicator comprising information about the first set of codewords.

38. The communications device of claim 34, wherein the first set of codewords comprises N_{cw} codewords, where $N_{cw1}=N_{cw}$, and wherein the control symbols comprise hybrid automatic repeat requested (HARQ) positive acknowledgement (ACK)/negative acknowledgement (NACK) signals, rank indicator (RI) signals, or a combination thereof.

39. The communications device of claim 38, wherein the distributing unit is configured to time division multiplex the control symbols with the data symbols so that the control symbols are time-aligned across the multiple MIMO layers.

40. The communications device of claim 34, wherein the distributing unit is configured to distribute a size of the control symbols onto the first set of layers based on modulation and coding scheme (MCS) levels of the first set of codewords.

41. The communications device of claim 34, wherein the distributing unit is configured to distribute the control sym-

14

bols onto the first set of layers so that the control symbols are distributed to substantially the same resource elements across the first set of layers.

42. The communications device of claim 34, wherein the selecting unit is configured to select two different first sets of codewords for two different types of control symbols.

43. A communication device comprising:

an identifying unit configured to identify a type of control symbols to be transmitted on a plurality of multiple input, multiple output (MIMO) layers;

a selecting unit coupled to the identifying unit, the selecting unit configured to select a first set of codewords according to the type of the control symbols; and

a multiplexer coupled to the identifying unit, the multiplexer configured to multiplex the control symbols with data on the first set of codewords, wherein a quantity of the control symbols for each of the MIMO layers is determined in accordance with a variable transmission rank-dependent offset of the first set of codewords, wherein the offset is different for different transmission ranks each having a different total number of the MIMO layers.

44. The communication device of claim 43, wherein the selecting unit is configured to select two or more codewords according to the type of the control symbols, and wherein the control symbols comprise hybrid automatic repeat requested (HARQ) positive acknowledgement (ACK)/negative acknowledgement (NACK) signals, rank indicator (RI) signals, or a combination thereof.

45. The communication device of claim 43, wherein the selecting unit is configured to select a single codeword according to the type of the control symbols, and wherein the control symbols comprise channel quality information (CQI), precoding matrix indicators (PMI), or a combination thereof.

46. The communication device of claim 45, wherein the first set of codewords is selected based on a modulating and coding scheme (MCS) level associated with the codewords.

* * * * *