



US009270301B2

(12) **United States Patent**
Väisänen et al.

(10) **Patent No.:** **US 9,270,301 B2**
(45) **Date of Patent:** ***Feb. 23, 2016**

(54) **METHOD AND ARRANGEMENT FOR TRANSMITTING AND RECEIVING RF SIGNALS THROUGH VARIOUS RADIO INTERFACES OF COMMUNICATION SYSTEMS**

(52) **U.S. Cl.**
CPC *H04B 1/0057* (2013.01); *H04B 1/0078* (2013.01); *H04B 1/0082* (2013.01); *H04B 1/30* (2013.01); *H04B 1/406* (2013.01); *H04W 88/06* (2013.01)

(71) Applicant: **Nokia Technologies Oy**, Espoo (FI)

(58) **Field of Classification Search**
None
See application file for complete search history.

(72) Inventors: **Risto Väisänen**, Salo (FI); **Kim Kaltiokallio**, Salo (FI)

(56) **References Cited**

(73) Assignee: **Nokia Technologies Oy**, Espoo (FI)

U.S. PATENT DOCUMENTS

(*) Notice: Subject to any disclaimer, the term of this patent is extended or adjusted under 35 U.S.C. 154(b) by 0 days.

4,254,504 A 3/1981 Lewis et al.
4,395,776 A 7/1983 Naito et al.

(Continued)

This patent is subject to a terminal disclaimer.

FOREIGN PATENT DOCUMENTS

(21) Appl. No.: **14/272,820**

CN 1148444 A 4/1997
CN 1187270 A 7/1998

(Continued)

(22) Filed: **May 8, 2014**

OTHER PUBLICATIONS

(65) **Prior Publication Data**

US 2015/0094001 A1 Apr. 2, 2015

HTC Corporation and Nokia Corporation, Grounds of Invalidity, Claim No. HC12 F02047, executed May 17, 2012, 2 pages.

(Continued)

Related U.S. Application Data

(63) Continuation of application No. 14/272,191, filed on May 7, 2014, now Pat. No. 8,838,049, which is a continuation of application No. 13/614,272, filed on Sep. 13, 2012, now Pat. No. 8,755,834, which is a

(Continued)

Primary Examiner — Lana N Le

(74) *Attorney, Agent, or Firm* — Banner & Witcoff, Ltd.

(30) **Foreign Application Priority Data**

Nov. 26, 1998 (FI) 982559

(57) **ABSTRACT**

A method and arrangement for transmitting and receiving RF signals, associated with different radio interfaces of communication systems, employ a direct conversion based transceiver which substantially comprises one receive signal branch and one transmit signal branch. Mixing frequencies of the different systems are generated by a single common by use of an output frequency divider in combination with the synthesizer, and by use of filtering corresponding to a system channel bandwidth by means of a controllable low-pass filter operating at baseband frequency.

(51) **Int. Cl.**

H04B 1/04 (2006.01)

H04B 1/00 (2006.01)

(Continued)

122 Claims, 2 Drawing Sheets

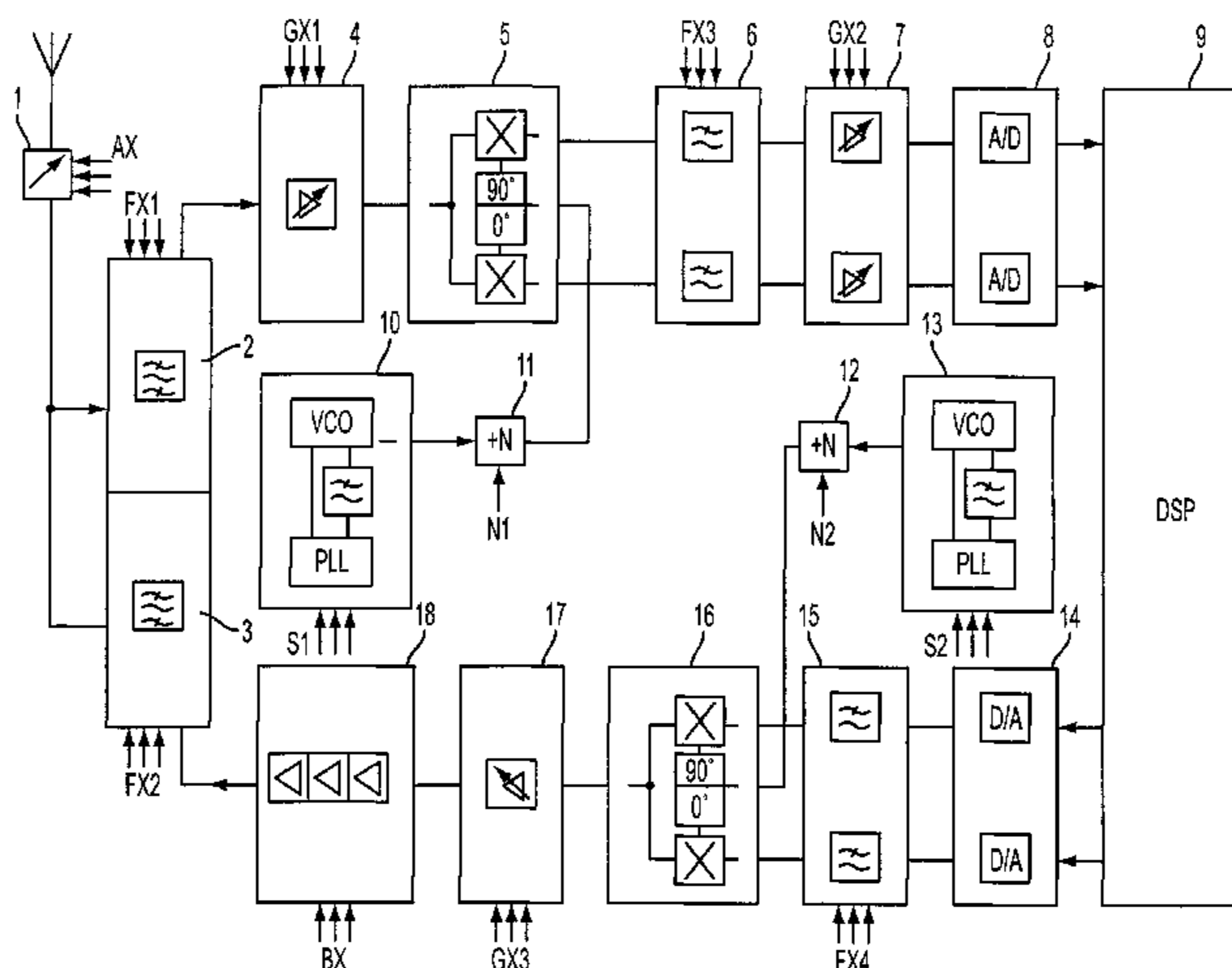

Related U.S. Application Data

continuation of application No. 12/136,465, filed on Jun. 10, 2008, now Pat. No. 8,768,408, which is a continuation of application No. 09/856,746, filed as application No. PCT/FI99/00974 on Nov. 25, 1999, now Pat. No. 7,415,247.

(51) **Int. Cl.**

H04B 1/30 (2006.01)
H04B 1/403 (2015.01)
H04W 88/06 (2009.01)

(56)

References Cited

U.S. PATENT DOCUMENTS

4,731,796 A 3/1988 Masterton et al.
 4,736,390 A 4/1988 Ward et al.
 4,761,798 A 8/1988 Griswold, Jr. et al.
 4,768,187 A 8/1988 Marshall
 4,870,699 A 9/1989 Garner et al.
 4,972,455 A 11/1990 Phillips et al.
 5,187,809 A 2/1993 Rich et al.
 5,291,516 A 3/1994 Dixon et al.
 5,438,692 A 8/1995 Mohindra
 5,465,409 A 11/1995 Borrás et al.
 5,483,691 A 1/1996 Heck et al.
 5,511,235 A 4/1996 Duong et al.
 5,519,885 A 5/1996 Vaisanen
 5,548,825 A 8/1996 Maemura et al.
 5,557,642 A 9/1996 Williams
 5,564,076 A 10/1996 Auvray
 5,574,985 A 11/1996 Ylikotila
 5,584,068 A 12/1996 Mohindra
 5,590,412 A 12/1996 Sawai et al.
 5,642,378 A 6/1997 Denheyer et al.
 5,694,414 A 12/1997 Smith et al.
 5,710,998 A 1/1998 Opas
 5,722,053 A 2/1998 Kornfeld et al.
 5,732,330 A 3/1998 Anderson et al.
 5,734,970 A 3/1998 Saito
 5,751,249 A 5/1998 Baltus et al.
 5,752,169 A 5/1998 Hareyama et al.
 5,757,858 A 5/1998 Black et al.
 5,758,266 A 5/1998 Kornfeld et al.
 5,758,271 A 5/1998 Rich et al.
 5,786,782 A 7/1998 Ostman et al.
 5,794,119 A 8/1998 Evans et al.
 5,794,159 A 8/1998 Portin
 5,796,772 A 8/1998 Smith et al.
 5,819,165 A 10/1998 Hulkko et al.
 5,822,366 A 10/1998 Rapeli
 5,825,809 A 10/1998 Sim
 5,867,535 A 2/1999 Phillips et al.
 5,872,810 A 2/1999 Philips et al.
 5,894,592 A 4/1999 Brueske et al.
 5,896,562 A * 4/1999 Heinonen H03D 7/165
 455/552.1
 5,909,643 A 6/1999 Aihara
 5,926,749 A 7/1999 Igarashi et al.
 5,926,750 A 7/1999 Ishii
 5,953,641 A 9/1999 Auvray
 5,955,992 A 9/1999 Shattil
 5,963,852 A 10/1999 Schlang et al.
 5,983,081 A 11/1999 Lehtinen
 6,006,080 A 12/1999 Kato et al.
 6,009,119 A 12/1999 Jovanovich et al.
 6,009,126 A 12/1999 Van Bezooijen
 6,014,571 A 1/2000 Enoki
 6,018,553 A 1/2000 Sanielevici et al.
 6,028,850 A 2/2000 Kang
 6,029,052 A 2/2000 Isberg et al.
 6,029,058 A 2/2000 Namgoong et al.
 6,049,722 A 4/2000 Umemoto et al.
 6,054,887 A 4/2000 Horie et al.
 6,075,996 A 6/2000 Srinivas

6,081,697 A 6/2000 Haartsen
 6,085,075 A 7/2000 Van Bezooijen
 6,125,268 A 9/2000 Boesch et al.
 6,134,452 A 10/2000 Hufford et al.
 6,151,354 A 11/2000 Abbey
 6,163,710 A 12/2000 Blaser et al.
 6,167,245 A 12/2000 Welland et al.
 6,169,733 B1 1/2001 Lee
 6,175,746 B1 1/2001 Nakayama et al.
 6,188,877 B1 2/2001 Boesch et al.
 6,194,947 B1 2/2001 Lee et al.
 6,208,875 B1 3/2001 Damgaard et al.
 6,215,988 B1 4/2001 Matero
 6,243,569 B1 6/2001 Atkinson
 6,256,511 B1 7/2001 Brown et al.
 6,269,253 B1 7/2001 Maegawa et al.
 6,278,864 B1 8/2001 Cummins et al.
 6,282,184 B1 8/2001 Lehman et al.
 6,298,226 B1 10/2001 Lloyd et al.
 6,308,050 B1 10/2001 Eklof
 6,337,976 B1 1/2002 Kudou
 6,356,746 B1 3/2002 Katayama
 6,366,622 B1 4/2002 Brown et al.
 6,366,765 B1 4/2002 Hongo et al.
 6,411,646 B1 6/2002 Walley et al.
 6,415,001 B1 7/2002 Li et al.
 6,434,401 B1 8/2002 Recouly
 6,438,462 B1 8/2002 Hanf et al.
 6,449,264 B1 9/2002 Lehtinen et al.
 6,484,038 B1 11/2002 Gore et al.
 6,484,042 B1 11/2002 Loke
 6,510,310 B1 1/2003 Muralidharan
 6,516,023 B1 2/2003 Kveim et al.
 6,535,499 B1 3/2003 Futamura et al.
 6,535,561 B2 3/2003 Boesch et al.
 6,535,748 B1 3/2003 Vuorio et al.
 6,584,090 B1 6/2003 Abdelgany et al.
 6,584,305 B1 6/2003 Sudo et al.
 6,600,911 B1 7/2003 Morishige et al.
 6,621,853 B1 9/2003 Ku
 6,697,606 B1 2/2004 Wagemans et al.
 6,813,485 B2 11/2004 Sorrells et al.
 6,826,237 B1 11/2004 Minnis
 6,954,624 B2 10/2005 Hamalainen
 7,065,327 B1 6/2006 Macnally et al.
 7,082,293 B1 7/2006 Rofougaran et al.
 7,415,247 B1 8/2008 Vaisanen et al.
 7,672,645 B2 3/2010 Kilpatrick et al.
 8,102,929 B2 1/2012 Soliman et al.
 8,768,408 B2 * 7/2014 Vaisanen et al. 455/552.1
 2006/0178165 A1 * 8/2006 Vassiliou et al. H04B 1/30
 455/127.4
 2008/0176523 A1 * 7/2008 Sutton et al. H04B 1/0475
 455/76

FOREIGN PATENT DOCUMENTS

DE 19712161 A1 9/1998
 DE 69735156 T2 8/2006
 DE 69736793 T2 2/2007
 DE 69737000 T2 7/2007
 EP 0581572 A1 2/1994
 EP 0581573 A1 2/1994
 EP 0599409 A2 6/1994
 EP 0631400 A1 12/1994
 EP 0633674 A2 1/1995
 EP 653851 A2 5/1995
 EP 0782358 A2 7/1997
 EP 0797311 A2 9/1997
 EP 0798880 A2 10/1997
 EP 0800283 A2 10/1997
 EP 0809366 A2 11/1997
 EP 0813312 A2 12/1997
 EP 0823788 A2 2/1998
 EP 0878974 A1 11/1998
 GB 2215945 A 9/1989
 GB 2287144 A 9/1995
 GB 2312107 A 10/1997
 GB 2312108 A 10/1997

(56)

References Cited

FOREIGN PATENT DOCUMENTS

JP	05075495	3/1993
JP	H06-188781 A	7/1994
JP	H06-260961 A	9/1994
JP	07-059162	3/1995
JP	H10-504698 A	2/1996
JP	H09-506492 A	3/1996
JP	H08-293815 A	11/1996
JP	H08-316789 A	11/1996
JP	09-130275	5/1997
JP	H09-163450 A	6/1997
JP	09-275358	10/1997
JP	H09-261104 A	10/1997
JP	09-312578	12/1997
JP	H09-321691 A	12/1997
JP	10-032520	2/1998
JP	H10-032519 A	2/1998
JP	10-065749	3/1998
JP	H10-084583 A	3/1998
JP	10-093475	4/1998
JP	10-224250	8/1998
JP	H10-242882 A	9/1998
JP	3080879 B2	6/2000
WO	9221195 A1	11/1992
WO	9706604 A1	2/1997
WO	9853625 A1	11/1998
WO	9901933 A2	1/1999
WO	9917445 A1	4/1999

OTHER PUBLICATIONS

Behzad Razavi, RF Microelectronics, 1998, Prentice Halls, Inc., 10th Edition, pp. 150-153.

Proof of Publication date (Nov. 6, 1997) of book Razavi, Behzad, RF Microelectronics, Prentice Hall, 1st Edition by amazon.com under product detail section, and paper of when it was received by USPTO (Nov. 23, 1998).

Weidong, et al., "Software Radio: Technology & Implementation", ICCT'98.

UK Revocation action, *HTC Corporation v. Nokia Corporation*, Claim No. He12F02047 issued May 17, 2012, 50 pages.

U.S. District Court, District of Delaware (Wilmington), Civil Docket for Case #: 1:12-cv-00549-LPS, *Nokia Corporation et al v. HTC Corporation et al*, Jul. 2, 2012, 2 pages.

U.S. International Trade Commission, Docket Report of 337-TA-847, found at <<https://edis.usitc.gov/edis3-external/direct.svc>>, 8 pages, Jul. 2, 2012.

Abidi, A.A., Direct Conversion Radio Transceivers for Digital Communications, Dept. of Electr. Eng., California Univ., Los Angeles, CA; Publication date Dec. 1995, pp. 1339-1410, vol. 30, No. 12.

Gray, P.R., Meyer, R.G., Future Directions in Silicon ICS for RF Personal Communications, Dept. of Electr. Eng. & Comput. Sci., California University, Berkeley, CA; Publication Date May 14, 1995, pp. 83-90.

Hanusch, T., et al., "Analog Baseband-IC for Dual Mode Direct Conversion receiver", Proc. ESSCIRC., Sep. 1996, pp. 244-249.

Fernandez-Duran, A., et al., "Zero-IF Receiver Architecture for Multistandard Compatible Radio Systems. GIRAFE Project", IEEE 1996, pp. 1052-1056.

Nguyen, C.T.-C., "Communications Applications of Microelectromechanical Systems", Proceedings, 1998 Sensors Expo, May 19-21, 1998, pp. 447-455.

Tham, J.L., et al., "A Direct-Conversion Transceiver Chip Set for 900 MHz (ISM Band) Spread-Spectrum Digital Cordless Telephone", ISCAS 1996 Conference, May 12-15, vol. 4, 1996, pp. 85-88.

Kuo, C., "Multi-Standard DSP Based Wireless System", ICSP'98 Conference, vol. II of II, Oct. 12-16, 1998, pp. 1712-1728.

Beckwith, B., "Dual Band Integrated Power Amplifier with Switchable Interstage Match", Motorola, Jun. 1997, pp. 84-85.

Tham, J.L., et al., "A 2.7V 900MHz/1.96GHz Dual-Band Transceiver IC for Digital Wireless Communication", IEEE CICC 1998 Conference, pp. 559-569.

B. Gilbert, "A Precise Four-Quadrant Multiplier with Subnanosecond Response," IEEE Journal Solid-State Circuits, Dec. 1968.

Sergio Graffi, et al., "New Macromodels and Measurements for the Analysis of EMI Effects in 741 Op-Amp Circuits," IEEE Trans. on Electromagnetic Compatibility, Feb. 1991.

Nullity Complaint *HTC Europe Co. Ltd. v. Nokia Corporation* Re: EP1133831 (DE69942878.5), dated Jan. 17, 2013, with English translation, 59 pages.

De Response to Nullity Action as filed, dated Oct. 7, 2013, with English translation, 91 pages.

Translation Statement of Defence Regional Court Dusseldorf, Hogan Lovells, dated Jan. 18, 2013, 26 pages. (redacted). (41 pages not redacted).

Replik LG Dusseldorf, dated Jun. 7, 2013, with English translation, 49 pages (redacted). (71 pages not redacted).

Summons to Appear Before the Tribunal De Grande Instance de Paris, Sep. 2013, with English translation, 134 pages.

Expert Report of James Arthur Crawford, HTC Corporation and Nokia Corporation, executed Jul. 24, 2013, 86 pages.

Final Expert Report of Professor Bram Nauta (Patents and Prior Art), HTC Corporation and Nokia Corporation, executed Jul. 5, 2013, 106 pages.

Final Reply Report of Professor Bram Nauta (Patents and Prior Art), HTC Corporation and Nokia Corporation, executed Jul. 25, 2013, 18 pages.

Grounds of Invalidity, HTC Corporation and Nokia Corporation, executed May 17, 2012, 2 pages.

Document HTC115, HTC Europe Co. Ltd./Nokia Corporation, dated Jan. 17, 2013, 30 pages (HL4).

Document HTC115, HTC Europe Co. Ltd./Nokia Corporation, dated Nov. 15, 2013, 36 pages. (HL24).

International Organisation for Standardisation Organisation Internationale de Normalisation, ISO/IEC JTC/SC29/WG11, Coding of Moving Pictures and Associated Audio, N0801, Information Technology—Generic Coding of Moving Pictures and Associated Audio: Systems, Recommendation H.222.0, ISO/IEC 13818-1, draft of 1540 Sun Nov. 13, 1994, 161 pages.

Document, Samson & Partner, HTC Europe Co. Ltd. and Nokia Corporation, dated Oct. 7, 2013, 47 pages, German language (K94).

Defendant/Counteraction Claimant's Response to Claimant/Counteraction Defendant's Notice to Admit Facts dated Mar. 27, 2013, HTC Corporation and Nokia Corporation, 9 pages.

RF CASE/CASE 1, HTC's Statements of Case on Validity on EP(UK) 0 998 024 and EP(UK) 1 133 831, HTC Corporation and Nokia Corporation, 6 pages, executed Jan. 14, 2013.

Public Version of Initial Determination on Violation of Section 337 and Recommended Determination on Remedy and Bond, In the Matter of Certain Electronic Devices, Including Mobile Phones and Tablet Computers, and Components, Thereof, Investigation No. 337-TA-847, dated Sep. 23, 2013, 239 pages.

Order No. 9: Errata, In the Matter of Certain Electronic Devices, Including Mobile Phones and Tablet Computers, and Components Thereof, Investigation No. 337-TA-847, dated Mar. 25, 2013, 3 pages.

Order No. 8: Construing Terms of the Asserted Patents, In the Matter of Certain Electronic Devices, Including Mobile Phones and Tablet Computers, and Components Thereof, Investigation No. 337-TA-847, dated Mar. 21, 2013, 84 pages.

Respondents Htc Corp. and HTC America, Inc.'s Opening Claim Construction Brief, Investigation No. 337-Ta-847, executed Dec. 20, 2012, 63 pages.

Complainant's Nokia Corporation, Nokia Inc., and Intellisync Corporation Opening Claim Construction Brief, Investigation No. 337-TA-847, executed Dec. 20, 2012, 106 pages.

Respondents HTC Corp. and HTC America, Inc.'s Responsive Claim Construction Brief, Investigation No. 337-TA-847, executed Jan. 8, 2013, 42 pages.

Complainants' Nokia Corporation, Nokia Inc., and Intellisync Corporation Responsive Claim Construction Brief, Investigation No. 337-TA-847, executed Jan. 8, 2013, 48 pages.

(56)

References Cited

OTHER PUBLICATIONS

Complainants' Nokia Corporation, Nokia Inc., and Intellisync Corporation Post-Markman-Hearing Brief, Investigation No. 337-TA-847, executed Feb. 13, 2013, 49 pages.
Respondents HTC Corp. and HTC America, Inc's Supplemental Claim Construction Brief, Investigation No. 337-TA-847, executed Feb. 13, 2013, 43 pages.

HTC Reply with English Translation dated Nov. 15, 2013, 71 pages.
Complaint, HTC with English translation, dated May 2, 2012, 92 pages.

MC 1496 Datasheet, Motorola, Balanced Modulators/Demodulators, 1996, 12 pages.

Rejoinder EP1133831 B1, *Bird & Bird LLP v. Hogan Lovells International LLP*, document dated Nov. 15, 2013, 87 pages.

* cited by examiner

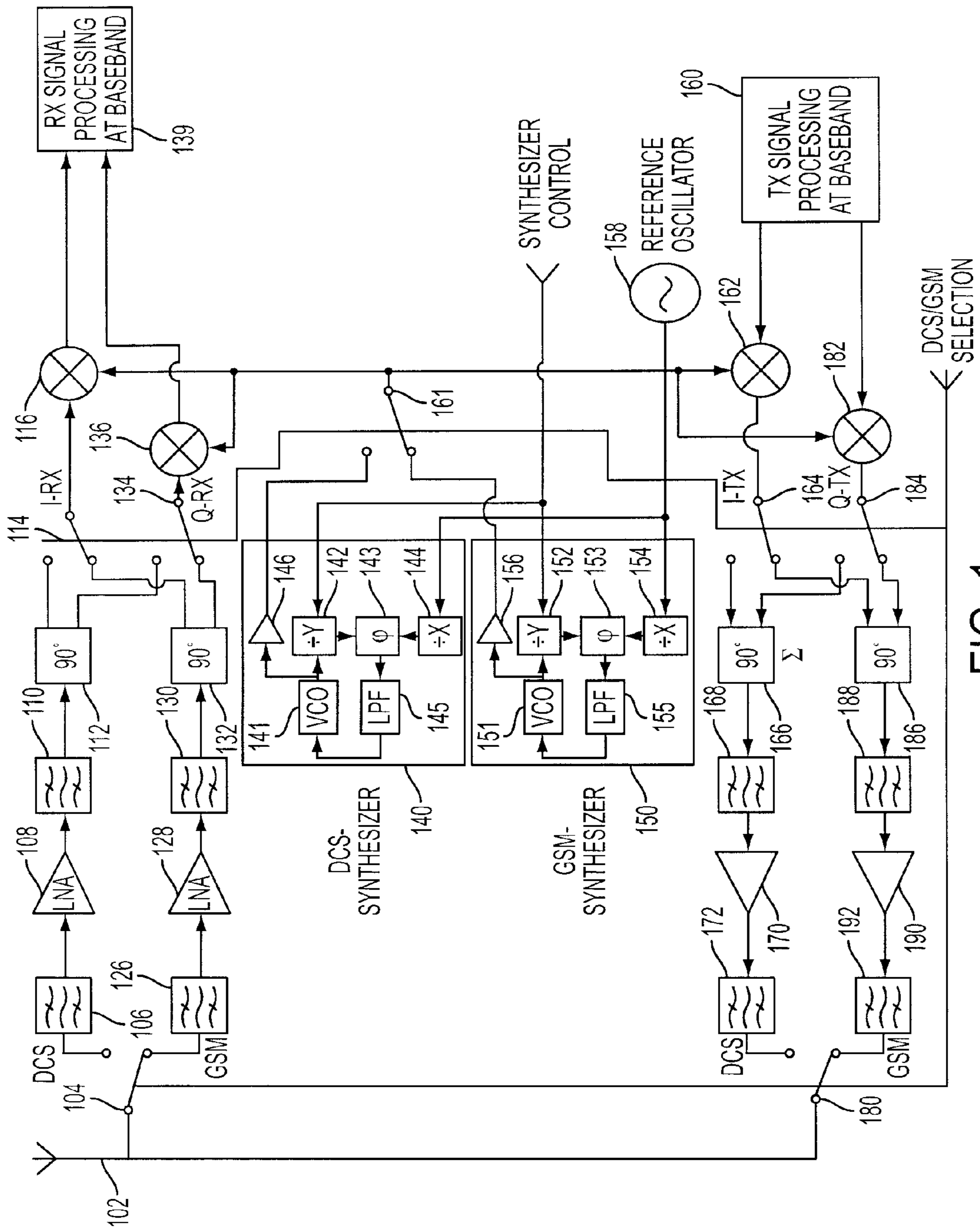

FIG. 1

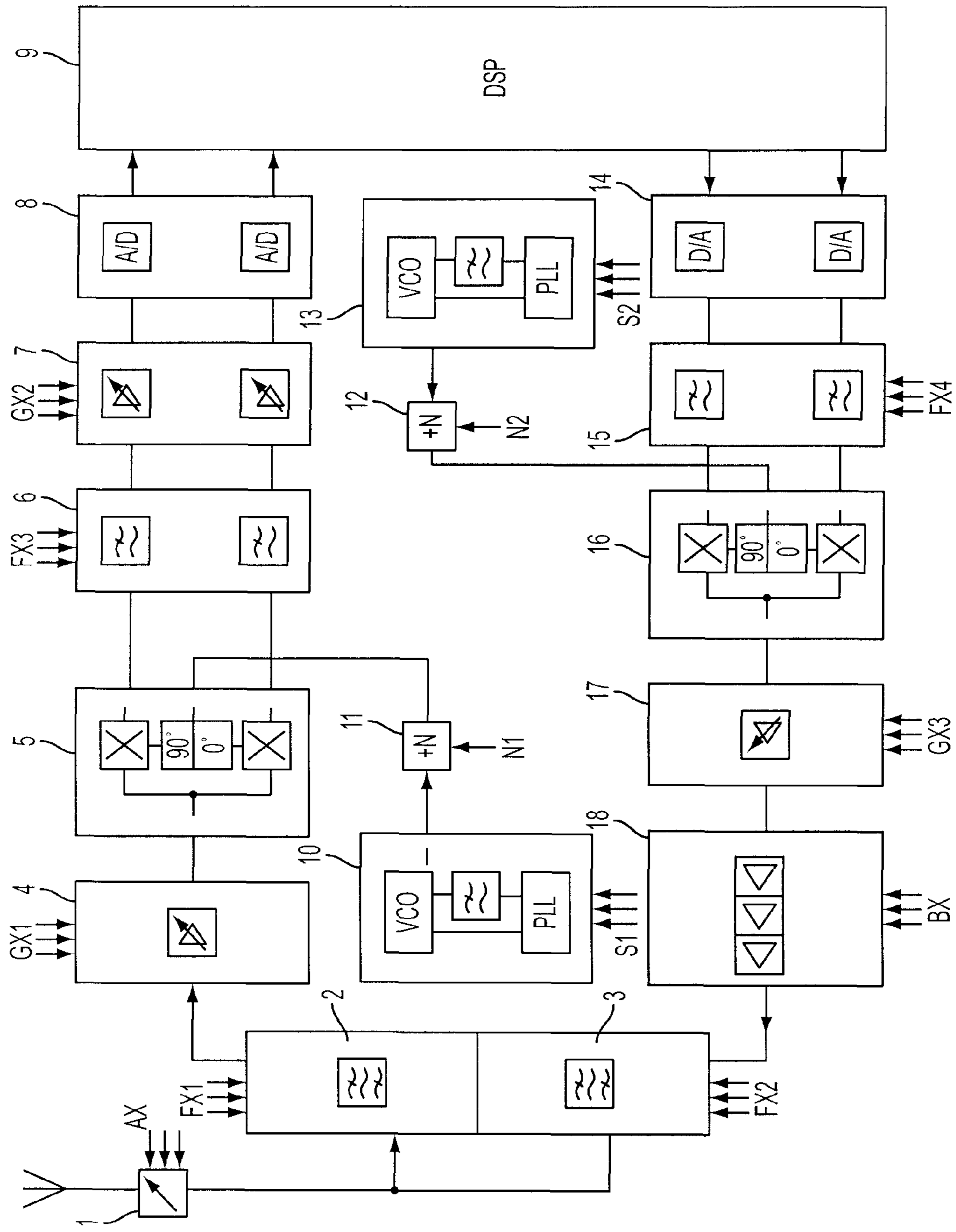

FIG. 2

**METHOD AND ARRANGEMENT FOR
TRANSMITTING AND RECEIVING RF
SIGNALS THROUGH VARIOUS RADIO
INTERFACES OF COMMUNICATION
SYSTEMS**

CROSS-REFERENCE TO RELATED
APPLICATION(S)

This application is a continuation of U.S. application Ser. No. 14/272,191, filed May 7, 2014, which is a continuation of U.S. application Ser. No. 13/614,272, filed Sep. 13, 2012, which is a continuation of U.S. application Ser. No. 12/136,465, filed Jun. 10, 2008, which is a continuation of U.S. application Ser. No. 09/856,746, filed May 24, 2001 (issued as U.S. Pat. No. 7,415,247 on Aug. 19, 2008), which is a U.S. national stage of PCT/FI99/00974, filed Nov. 25, 1999, which is based on and claims priority to Finnish application no. 982559, filed Nov. 26, 1998, all incorporated by reference herein.

The invention relates to a method and arrangement for transmitting and receiving RF signals associated with various radio interfaces of communication systems. The invention finds particular utility in transceivers of general-purpose mobile stations.

Mobile communication systems are developing and expanding rapidly which has led to a situation in which there are in many areas systems complying with several different standards. This has brought about a need for mobile stations that can be used in more than one system. Good examples are the digital systems called GSM (Global System for Mobile communications) and DCS (Digital Cellular System), which operate on different frequency bands but have otherwise similar radio interfaces. In addition, the modulation, multiplexing and coding schemes used may be different. The systems mentioned above use the time division multiple access (TDMA) method; other methods include the frequency division multiple access (FDMA) and code division multiple access (CDMA).

One possible way of making a mobile station capable of operating in multiple systems is to have in the mobile station completely separate signal paths for each system. This, however, would lead to an unreasonable increase in the mobile station size and manufacturing costs. Therefore, the goal is to design a mobile station in which the differences relating to the radio interfaces of the various systems could be largely dealt with by means of programming, instead of having separate signal processing paths.

It is known e.g. from patent application document EP 653851 a transceiver arrangement using one local oscillator the frequency of which falls between the lower operating frequency band and the higher operating frequency band such that one and the same intermediate frequency (IF) can be used for both operating frequency bands. However, the disadvantage of such a solution is that the necessary IF stages make the implementation rather complex, and the manufacturing costs of the device will be high because of the great number of components. Furthermore, the IF stages require filters in order to eliminate spurious responses and spurious emissions. In addition, channel filtering at the intermediate frequency sets great demands on the IF filters.

In a direct-conversion, or zero-IF, receiver the radio-frequency (RF) signal is directly converted into baseband without any intermediate frequencies. Since no IF stages are needed, the receiver requires only a few components, therefore being an advantageous solution for general-purpose mobile stations which have multiple signal branches for dif-

ferent systems. To aid in understanding the problems relating to the direct conversion technique and prior art it is next described in more detail a prior-art solution.

FIG. 1 shows a direct conversion based arrangement for realizing a dual frequency band transceiver, known from the Finnish Patent document FI 100286. Depending on the receive frequency band, a RF signal received by an antenna is coupled by means of switch **104** either to a first receive branch (DCS) or second receive branch (GSM).

If the received signal is in the DCS frequency band, it is conducted to bandpass filter **106**, low-noise amplifier (LNA) **108** and bandpass filter **110**. After that the signal is brought to block **112** which produces signal components having a 90-degree phase difference. The in-phase component I and quadrature component Q are further conducted by means of switches **114** and **134** to mixers **116** and **136**. The mixers get their mixing signals from a DCS synthesizer **140** the frequency of which corresponds to the received carrier frequency so that the mixing produces the in-phase and quadrature components of the complex baseband signal. The baseband signal is further processed in the receive (RX) signal processing unit, block **139**.

If the signal received is a GSM signal, switch **104** directs the received signal to the GSM branch which comprises, connected in series bandpass filter **126**, low-noise amplifier **128**, bandpass filter **130** and phase shifter **132** which generates two signals with a mutual phase difference of 90 degrees. The signals are further conducted by means of switches **114** and **134** to mixers **116** and **136** where the mixing frequency is now determined by a signal coming from the GSM synthesizer **150** via switch **161**. The signals produced by the mixers are further conducted to the baseband RX signal processing unit **139**.

The DCS synthesizer comprises in a known manner a phase-locked loop (PLL) which includes a voltage-controlled oscillator (VCO) **141** the output signal of which is amplified at amplifier **146** thus producing the synthesizer output signal. The frequency of the signal from oscillator **141** is divided by an integer Y in divider **142** and the resulting signal is conducted to phase comparator **43**. Similarly, the frequency of the signal generated by reference oscillator **158** is divided by an integer X in divider **144** and conducted to phase comparator **143**. The phase comparator produces a signal proportional to the phase difference of said two input signals, which signal is conducted to a low-pass filter (LPF) **145** producing a filtered signal that controls the voltage-controlled oscillator **141**. The phase-locked loop described above operates in a known manner in which the output frequency of the synthesizer becomes locked to the frequency coming to the phase comparator from the reference frequency branch. The output frequency is controlled by varying the divisor Y.

The GSM synthesizer **150** comprises a voltage-controlled oscillator **150**, amplifier **156**, dividers **152** and **154**, phase comparator **153** and a low-pass filter **155**. The GSM synthesizer operates like the DCS synthesizer described above, but the output frequency of the GSM synthesizer corresponds to GSM frequency bands.

In the transmitter part, a baseband complex transmit (TX) signal is processed in a TX signal processing unit wherefrom the in-phase and quadrature components of the signal are conducted to mixers **162** and **182** that produce a carrier-frequency signal by multiplying the input signal by the mixing signal. If the transmission is at the DCS frequency, switch **161** selects the DCS synthesizer's output signal as the mixing signal. The carrier-frequency signal is conducted through switch **164** to the DCS branch where a 90-degree phase shift is first produced between the in-phase component and

quadrature component, and the resulting signals are then summed, block 166. The resulting DCS signal is conducted to bandpass filter 168, amplifier 170, and bandpass filter 172. The RF signal thus produced is further conducted to the antenna 102 via switch 180.

If the transmission is at the GSM frequency, the output signal of the GSM synthesizer is used as the mixing signal. The resulting carrier-frequency signal is conducted to the GSM branch in which it is processed in the same manner as in the DCS branch blocks 186, 188, 190 and 192. The RF signal thus produced is conducted to the antenna 102 via switch 180. One and the same antenna 102 can be used in both transmission and reception if the TX and RX circuits are coupled to the antenna through a duplex filter, for example. If the apparatus is designed to operate in two or more frequency bands, it needs separate filters for each frequency band.

The circuit arrangement described above has, however, some disadvantages. First, separate carrier-frequency signal branches in the receiver and in the transmitter add to the complexity, size and manufacturing costs of the transceiver. Second, each operating frequency band needs a separate synthesizer of its own.

An object of the invention is to provide a simple solution for realizing a programmable transceiver operating in a plurality of systems in such a manner that the aforementioned disadvantages related to the prior art can be avoided.

In the direct conversion based transceiver according to the invention signal processing can be performed using one and the same signal processing line regardless of the system. This is achieved using the signal processing steps set forth below.

The method according to the invention for processing signals received from different radio interfaces of communication systems is characterized in that it comprises steps in which

- a carrier-frequency signal is received from a radio interface,
- the carrier-frequency signal is bandpass-filtered,
- the filtered carrier-frequency signal is amplified,
- an RX mixing signal at the receive frequency is generated,
- a complex baseband signal is generated from the received carrier-frequency signal by mixing it with the RX mixing signal,
- the baseband signal generated is low-pass-filtered,
- the baseband signal generated is amplified,
- the baseband signal is converted digital, and
- the baseband signal converted digital is processed to produce an information signal encoded and modulated into the received signal.

The method according to the invention for processing signals transmitted to different radio interfaces of communication systems is characterized in that it comprises steps in which

- a digital baseband quadrature signal is generated on the basis of the information signal to be transmitted,
- the digital baseband signal is converted analog,
- a TX mixing signal at the transmit frequency is generated,
- a carrier-frequency transmission signal is generated from the baseband signal by mixing it with the TX mixing signal,
- the carrier-frequency signal generated is amplified, and
- the transmission signal is sent to the radio interface.

The direct-conversion receiver according to the invention operating at different interfaces of communication systems is characterized in that it comprises

- antenna means for receiving a radio-frequency signal,
- bandpass filter for filtering a carrier-frequency signal,

first RX amplifier for amplifying the filtered carrier-frequency signal,

means for generating an RX mixing signal at the receive frequency,

5 mixing means for generating a complex baseband signal from the received signal using the RX mixing signal,

low-pass filter for filtering the baseband signal,

second amplifier for amplifying the baseband signal,

analog-to-digital converter for converting the baseband signal digital, and

10 means for processing the baseband signal converted digital to produce an information signal encoded and modulated into the received signal.

The direct-conversion transmitter according to the invention operating at different radio interfaces of communication systems is characterized in that it comprises

means for generating a digital baseband quadrature signal on the basis of the information signal to be transmitted,

digital-to-analog converter for converting the baseband transmission signal analog,

20 synthesizer for generating a TX mixing signal at the transmit frequency,

mixing means for producing a signal at the carrier frequency from the baseband transmission signal using the TX mixing signal,

25 TX amplifier for amplifying the signal at the carrier frequency, and

antenna means for transmitting the amplified transmission signal at the carrier frequency.

Other preferred embodiments of the invention are described in the dependent claims.

In the present invention, signal band limiting is advantageously performed at the baseband frequency so that there is no need for "steep" filters and, therefore, system-specific filter lines. Filtering can thus be performed as low-pass filtering using a filter with a controllable cut-off frequency. This way, it is possible to completely avoid separate system-specific channel filtering circuits.

To enable the generation of mixing frequencies of the different operating frequency bands by one and the same synthesizer it is advantageously used frequency division of the synthesizer output signal. If the synthesizer's operating frequency is set higher than the frequencies used in the systems, it is possible to generate, in conjunction with the synthesizer frequency division, two mixing signals with a 90-degree phase difference, thus avoiding the need for phase shifters on the signal line and achieving a good phase accuracy.

Using the solution according to the invention it is possible to realize a general-purpose transceiver which is considerably simpler and more economical to manufacture than prior-art solutions. The circuit arrangement according to the invention requires only one TX signal branch and one RX signal branch. Moreover, one and the same synthesizer may be used to generate the mixing signals. Furthermore, there is no need for channel filters operating at the radio frequency. Therefore, the circuitry can be easily integrated. Since the invention involves only a few components, the advantages of the transceiver according to the invention include small size and low power consumption.

The invention will now be described in more detail with reference to the accompanying drawing wherein

FIG. 1 shows a block diagram of a dual-band direct-conversion transceiver according to the prior art,

65 FIG. 2 shows in the form of block diagram a solution according to the invention for a direct-conversion transceiver operating in multiple systems.

5

FIG. 1 was already discussed in conjunction with the description of the prior art. Next, a transceiver according to the invention will be described, referring to FIG. 2.

FIG. 2 shows in the form of block diagram a transceiver according to the invention. A RF signal received through an antenna is conducted via matching circuits 1 to controllable bandpass filters 2. The matching circuits 1 may advantageously be controllable (AX) with respect to the operating frequency band. A controllable bandpass filter 2 may be advantageously realized using a plurality of bandpass filters so that the RF signal is conducted via switch elements controlled by a control signal FX1 from the matching circuit 1 to the bandpass filter that corresponds to the selected operating frequency band. The bandpass filter may also be realized so as to be adjustable and tuneable by means of programming. The bandpass filtered carrier-frequency signal is further conducted to a low-noise amplifier 4, the gain of which is advantageously controllable. The control signal is marked GX1 in the drawing. In addition to amplifier 4, it is also possible to have integrated amplifiers in connection with the bandpass filters.

The signal is then conducted to a mixer 5 in which the carrier-frequency signal is mixed with an RX mixing signal at the receive frequency to produce a baseband quadrature signal. The RX mixing signal is advantageously generated by a synthesizer 10 the output signal frequency of which is divided by a divider 11 so as to correspond to the selected receive frequency. The synthesizer 10 operates in a similar manner as the synthesizers depicted in FIG. 1. Thus it comprises a voltage-controlled oscillator VCO which produces an output signal. The frequency of the VCO output signal is divided by S1 in a divider in the phase-locked loop PLL. The resulting signal is conducted to a first input of a phase comparator in the phase-locked loop. Similarly, the frequency of a signal generated by a reference oscillator in the phase-locked loop PLL is divided by an integer and conducted to a second input of the phase comparator. The phase comparator produces a signal which is proportional to the phase difference of the two input signals and conducted to a low-pass filter, and the filtered signal then controls the voltage-controlled oscillator VCO. The output frequency is controlled by varying the divisor S1.

The synthesizer output signal is divided in divider 11 by N1 so that the RX mixing signal corresponds to the selected receive frequency band. The output frequency of the synthesizer may be e.g. in the 4-GHz band, so that with 2-GHz systems the synthesizer output frequency is divided by two, and with 1-GHz systems it is divided by four (N1). This way, systems operating in the 1-GHz and 2-GHz bands can be covered with a synthesizer the operating frequency band of which is narrow with respect to the operating frequency.

To produce a quadrature baseband signal the mixer needs two mixing signals with a phase shift of 90 degrees. Phase-shifted components may be produced by a phase shifter in connection with the mixer or they may be produced as quotients generated already in the frequency divider 11, thus achieving an accurate phase difference. Therefore, it is advantageous to use a synthesizer operating frequency which is a multiple of the highest system frequency.

The in-phase component 1 and quadrature component Q from the mixer 5 are further conducted to low-pass filters 6. The higher cut-off frequency of the low-pass filters is advantageously controllable with control signal FX3. Thus the filtering can be performed at a bandwidth corresponding to the selected radio interface, and since the filtering is performed at baseband, it is easy to get the filtering function steep. Also, no strict demands are set on the bandpass filtering (2) of the RF signal.

6

The baseband signal is further conducted to a gain control block 7 which possibly includes an offset voltage correction block. On the other hand, considering the broad bandwidth of the CDMA system, the offset voltage can easily be removed by high-pass filtering. The amplifier advantageously realizes automatic gain control (AGC). Finally, the signal is converted digital in an analog-to-digital converter 8, and the digital baseband signal is further processed in a digital signal processor (DSP) 9. Channel filtering may also be performed digitally in the DSP, whereby the low-pass filtering of the baseband signal may be performed using a fixed cut-off frequency. Then, however, the dynamics of the analog-to-digital converter must be considerably better.

In the transmitter part, a quadrature baseband signal is first digitally generated in block 9 on the basis of the information signal to be sent. The components of the digital signal are converted analog by digital-to-analog converters 14, whereafter the analog signals are low-pass filtered by low-pass filters 15. Advantageously, the cutoff frequency of the low-pass filters can be controlled with control signal FX4 so as to correspond to the specifications of the selected radio interface.

A TX mixing signal at the carrier frequency is generated by a synthesizer 13 and divider 12. The synthesizer 13 operates in a similar manner as the synthesizer 10 in the receiver part. Moreover, the synthesizers may share a reference oscillator. The frequency of the synthesizer output signal is controlled with control signal S2 within the synthesizer's operating frequency range. The frequency of the output signal from synthesizer 13 is divided in divider 12 so as to correspond to the selected transmission frequency band. Components phase-shifted by 90 degrees are generated from the TX mixing signal in order to perform complex mixing in mixer 16. The phase-shifted components may be generated in the same way as in the receiver part.

The signal at the carrier frequency is then amplified in an amplifier 17, the gain of which is advantageously controllable in order to set the transmission power and realize automatic gain control (AGC). The control signal is marked GX3 in FIG. 2. The signal is then conducted to a power amplifier 18. The operating frequency band of the power amplifier is advantageously selectable with control signal BX. This can be achieved e.g. such that the amplifier comprises partly separate signal lines for the different operating frequency bands.

The RF signal generated is filtered by a bandpass filter 3. The pass band of the bandpass filter is advantageously controllable with control signal FX2. This can be realized in the same way as in the receiver part. The receiver and transmitter part filters 2 and 3 are advantageously realized in duplex filter pairs for each transmit-receive frequency band associated with a given system. The filters may advantageously be surface acoustic wave (SAW) or bulk acoustic wave (BAW) filters so that several filters with their switches may be attached to one component.

The control signals in the mobile station transceiver according to FIG. 2 are preferably generated in a control block of the mobile station which advantageously comprises a processing unit such as a microprocessor. The control block generates the signal on the basis of a system switch instruction input from the keypad of the mobile station, for example. System selection may be e.g. menu-based so that the desired system is selected by choosing it from a displayed menu by pressing a certain key on the keypad. The control block then

generates the control signals that correspond to the selected system. The system switch instruction may also come via the mobile communication system in such a manner that data received from the system may include a system switch instruction on the basis of which the control block performs the system switch. Advantageously, a control program is stored in a memory unit used by the control block, which control program monitors the received data and, as it detects a system switch instruction in the data, gives the control block an instruction to set the control signals into states according to the selection instruction.

The implementation of the blocks described above is not illustrated in more detail as the blocks can be realized on the basis of the information disclosed above, applying the usual know-how of a person skilled in the art.

Above it was described embodiments of the solution according to the invention. Naturally, the principle according to the invention may be modified within the scope of the invention as defined by the claims appended hereto, e.g. as regards implementation details and fields of application. It is especially noteworthy that the solution according to the invention may be well applied to communication systems other than the mobile communication systems mentioned above. Apart from the cellular radio interface proper, the solution may be used to realize e.g. a GPS receiver for the location of a mobile station or other apparatus. Furthermore, the operating frequencies mentioned are given by way of example only, and the implementation of the invention is in no way restricted to them.

It is also noteworthy that the solution according to the invention may be applied to all current coding techniques such as the narrow-band FDMA (Frequency Division Multiple Access) and TDMA (Time Division Multiple Access), as well as the broadband CDMA (Code Division Multiple Access) technique. In addition, the solution according to the invention may be used to realize an FM (Frequency Modulation) receiver.

Below is a table listing some of the so-called second generation mobile communication systems to which the present invention may be applied. The table shows the most important radio interface related characteristics of the systems.

CELLULAR SYSTEM									
	AMPS	IS-54/136	IS-95 US CDMA	GSM Global System for Mobile Communications	DCS 1800	PDC Personal Digital Cellular	DECT Digital European Cordless Telephone	PHS Personal Handy Phone System	
RX FREQ. (MHz)	869-894	869-894	869-894	935-960	1805-1880	810-826, 1429-1453	1880-1900	1895-1918	
TX FREQ. (MHz)	824-849	824-849	824-849	890-915	1710-1785	940-956 1477-1501	1880-1900	1895-1918	
RF BANDWIDTH	25 MHz	25 MHz	25 MHz	25 MHz	75 MHz	16 MHz, 24 MHz	20 MHz	23 MHz	
MULTIPLE ACCESS METHOD	FDMA	TDMA/ FDMA	CDMA/ FDMA	TDMA/ FDMA	TDMA/ FDMA	TDMA/ FDMA	TDMA/ FDMA	TDMA/ FDMA	
DUPLEX METHOD	FDD	FDD	FDD	FDD	FDD	FDD	TDD	TDD	
NUMBER OF CHANNELS	832	832, 3 users/ channel	20, 798 users/ channel	124, 8 users/ channel	374, 8 users/ channel	1600, 3 users/ channel	10, 12 users/ channel	300, 4 users/ channel	
CHANNEL SPACING	30 kHz	30 kHz	1250 kHz	200 kHz	200 kHz	25 kHz	1.728 MHz	300 kHz	
MODULATION	FM	$\pi/4$ DQPSK	QPSK/ OQPSK	GMSK 0.3 Gaussian filter	GMSK 0.3 Gaussian filter	$\pi/4$ DQPSK	GFSK 0.3 Gaussian filter	$\pi/4$ DQPSK	

Below is another table listing some of the so-called third generation mobile communication systems to which the present invention may be applied. The table shows the most important radio interface related characteristics of the system.

CELLULAR SYSTEM	WCDMA	
RX FREQ. (MHz)	2110-2170	1900-1920
TX FREQ. (MHz)	1920-1980	1900-1920
MULTIPLE ACCESS METHOD	CDMA	TDMA
DUPLEX METHOD	FDD	TDD
CHANNEL SPACING	5 MHz	5 MHz
MODULATION	QPSK	
CHANNEL BIT RATE	144 kb/s in rural outdoor, 500 kb/s in urban outdoor and up to 2 Mb/s in indoor	

The invention claimed is:

1. A direct-conversion transceiver capable of operating with a plurality of radio interfaces, comprising:
 - a first controllable bandpass filter configured to filter a received signal according to a first bandpass control signal that selects one of a plurality of passbands corresponding to a selected one of the plurality of radio interfaces, wherein the first controllable bandpass filter has a signal path common to the plurality of radio interfaces;
 - a low-noise amplifier configured to amplify the filtered received signal according to a first gain control signal that controls an amount of gain, wherein the low-noise amplifier has a signal path common to the plurality of radio interfaces;
 - a first programmable synthesizer configured to generate a first mixing signal according to a first mixing control signal corresponding to the selected one of the plurality of radio interfaces, wherein the first programmable synthesizer has a signal path common to the plurality of radio interfaces;
 - a first frequency divider coupled to the first programmable synthesizer and configured to divide a frequency of the first mixing signal by two to provide a first divided frequency signal according to a first divider control signal corresponding to the selected one of plurality of radio interfaces;
 - a first mixer coupled to the low-noise amplifier and configured to mix the amplified and filtered received signal with the first divided mixing signal to produce a first

baseband quadrature signal, wherein the first mixer has a signal path common to the plurality of radio interfaces and wherein the first mixer produces the first baseband quadrature signal on a basis of two 90-degree phase-

9

shifted components produced from the first frequency divider;

a first low-pass filter coupled to the first mixer and configured to low-pass filter the first baseband quadrature signal according to a first filter control signal corresponding to the selected one of the plurality of radio interfaces, wherein the first low-pass filter has a signal path common to the plurality of radio interfaces;

a first gain-controlled amplifier coupled to the first low-pass filter and configured to provide gain-controlled amplification of the first low-pass filtered baseband quadrature signal, wherein the first gain-controlled amplifier has a signal path common to the plurality of radio interfaces;

an analog-to-digital converter coupled to the first gain-controlled amplifier and configured to convert to digital form an output of the first gain-controlled amplifier;

a digital signal processor configured to receive digital output from the analog-to-digital converter and to further process said digital output;

a digital-to-analog converter coupled to the digital signal processor and configured to receive a second baseband quadrature signal therefrom and to provide analog output signals;

a second low-pass filter coupled to the digital-to-analog converter and configured to low-pass filter the analog output signals from the digital-to-analog converter according to a second filter control signal corresponding to the selected one of the plurality of radio interfaces, wherein the second low-pass filter has a signal path common to the plurality of radio interfaces;

a second programmable synthesizer configured to generate a second mixing signal according to a second mixing control signal corresponding to the selected one of the plurality of radio interfaces, wherein the second programmable synthesizer has a signal path common to the plurality of radio interfaces;

a second frequency divider coupled to the second programmable synthesizer and configured to divide a frequency of the second mixing signal by two to provide a second divided frequency signal according to a second divider control signal corresponding to the selected one of the plurality of radio interfaces;

a second mixer coupled to the second low-pass filter and configured to mix signals from the second low-pass filter and the second frequency divider to produce a carrier-frequency transmission signal, wherein the second mixer has a signal path common to the plurality of radio interfaces and wherein the second mixer produces the carrier-frequency transmission signal on the basis of two 90-degree phase-shifted components produced from the second frequency divider;

a second gain-controlled amplifier coupled to the second mixer and configured to control gain according to a second gain control signal corresponding to the selected one of the plurality of radio interfaces, wherein the second gain-controlled amplifier has a signal path common to the plurality of radio interfaces;

a power amplifier coupled to the second gain-controlled amplifier and configured to produce an amplified output using a frequency band determined on the basis of a power control signal corresponding to the selected one of the plurality of radio interfaces, wherein the power amplifier has a signal path common to the plurality of radio interfaces;

a second controllable bandpass filter configured to filter an output of the power amplifier according to a second

10

bandpass control signal that selects one of a second plurality of passbands corresponding to the selected one of the plurality of radio interfaces, wherein the second controllable bandpass filter has a signal path common to the plurality of radio interfaces; and

a microprocessor configured to generate one or more control signals to cause selection of the selected one of the plurality of radio interfaces, wherein at least one of the plurality of radio interfaces comprises a modulation, a channel spacing, and a channel bit rate that at least one other of the plurality of radio interfaces does not have.

2. A direct-conversion transmitter comprising:

a transmit synthesizer common to a plurality of radio interfaces of the direct-conversion transmitter and configured to generate a mixing signal;

a controllable low-pass filter common to the plurality of radio interfaces of the direct-conversion transmitter, the controllable low-pass filter configured to perform filtering of an analog baseband transmission signal using a controllable cut-off frequency according to which one of the plurality of radio interfaces of the direct-conversion transmitter is selected;

a frequency divider common to the plurality of radio interfaces of the direct-conversion transmitter, the frequency divider configured to divide a frequency of the mixing signal according to which one of the plurality of radio interfaces of the direct-conversion transmitter is selected, wherein the dividing produces two mixing signal components having a 90-degree phase difference; and

a controllable gain transmitter amplifier common to the plurality of radio interfaces of the direct-conversion transmitter and configured to amplify a carrier-frequency signal from a mixer at a gain controlled according to which one of the plurality of radio interfaces of the direct-conversion transmitter is selected, wherein at least one of the plurality of radio interfaces of the direct-conversion transmitter comprises a modulation, a channel spacing, and a channel bit rate that at least one other of the plurality of radio interfaces of the direct-conversion transmitter does not have.

3. The direct-conversion transmitter of claim 2, wherein the frequency divider is configured to divide the frequency of the mixing signal so as to correspond to a selected transmission frequency band of a radio interface of the plurality of radio interfaces.

4. The direct-conversion transmitter of claim 3, wherein a first radio interface of the plurality of radio interfaces employs a WCDMA system and a second radio interface of the plurality of radio interfaces employs a Global System for Mobile communications (GSM) system.

5. The direct-conversion transmitter of claim 3, wherein the direct-conversion transmitter is part of a transceiver that comprises a direct-conversion receiver.

6. The direct-conversion transmitter of claim 3, wherein the controllable low-pass filter and the controllable gain transmitter amplifier are part of a transmit path common to the plurality of radio interfaces.

7. The direct-conversion transmitter of claim 3, wherein a first radio interface of the plurality of radio interfaces employs a WCDMA system and a second radio interface of the plurality of radio interfaces employs a Global System for Mobile communications (GSM) system, and wherein the controllable low-pass filter and the mixer are part of a transmit path common to the plurality of radio interfaces.

8. The direct-conversion transmitter of claim 3, further comprising a digital-to-analog converter, wherein the digital-

11

to-analog converter, the controllable low-pass filter and the mixer are part of a transmit path common to the plurality of radio interfaces.

9. The direct-conversion transmitter of claim 2, wherein the frequency divider comprises a control input that determines a divisor by which the frequency of the mixing signal is divided.

10. The direct-conversion transmitter of claim 2, wherein the frequency divider is configured to produce the two mixing signal components as quotients of the division of the frequency of the mixing signal.

11. The direct-conversion transmitter of claim 10, wherein the frequency divider is configured to produce the two mixing signal components without the use of a phase shifter after the division of the frequency of the mixing signal.

12. The direct-conversion transmitter of claim 2, wherein the frequency divider is configured to produce the two mixing signal components using a phase shifter after the division of the frequency of the mixing signal.

13. The direct-conversion transmitter of claim 2 wherein the frequency divider is configured to divide the frequency of the mixing signal at least by two.

14. The direct-conversion transmitter of claim 13, further comprising an antenna and a digital-to-analog converter, wherein the antenna, the digital-to-analog converter, and the mixer are common to the plurality of radio interfaces, wherein a first radio interface of the plurality of radio interfaces employs a WCDMA system and a second radio interface of the plurality of radio interfaces employs a Global System for Mobile communications (GSM) system, and wherein the direct-conversion transmitter is part of a transceiver that comprises a direct-conversion receiver.

15. The direct-conversion transmitter of claim 2, wherein the frequency divider is configured to divide the frequency of the mixing signal at least by two and by four.

16. The direct-conversion transmitter of claim 15, wherein the controllable low-pass filter and the mixer are part of a transmit path common to the plurality of radio interfaces.

17. The direct-conversion transmitter of claim 15, wherein the controllable low-pass filter and the mixer are part of a transmit path common to the plurality of radio interfaces and wherein a first radio interface of the plurality of radio interfaces employs a WCDMA system and a second radio interface of the plurality of radio interfaces employs a Global System for Mobile communications (GSM) system and wherein the direct-conversion transmitter is part of a transceiver that comprises a direct-conversion receiver.

18. The direct-conversion transmitter of claim 15, wherein a first radio interface of the plurality of radio interfaces employs a WCDMA system and a second radio interface of the plurality of radio interfaces employs a Global System for Mobile communications (GSM) system and wherein the direct-conversion transmitter is part of a transceiver that comprises a direct-conversion receiver.

19. The direct-conversion transmitter of claim 18, wherein the controllable low-pass filter and the mixer are part of a transmit path common to the plurality of radio interfaces.

20. The direct-conversion transmitter of claim 19, wherein a power amplifier is common to the plurality of radio interfaces.

21. The direct-conversion transmitter of claim 15, further comprising a digital-to-analog converter, wherein the digital-to-analog converter and the mixer are common to the plurality of radio interfaces, wherein a first radio interface of the plurality of radio interfaces employs a WCDMA system and a second radio interface of the plurality of radio interfaces employs a Global System for Mobile communications

12

(GSM) system, and wherein the direct-conversion transmitter is part of a transceiver that comprises a direct-conversion receiver.

22. The direct-conversion transmitter of claim 2, wherein the frequency divider is configured to divide the frequency of the mixing signal by different divisors determined according to which one of the plurality of radio interfaces of the direct-conversion transmitter is selected.

23. The direct-conversion transmitter of claim 22, wherein the controllable low-pass filter and the mixer are part of a transmit path common to the plurality of radio interfaces.

24. The direct-conversion transmitter of claim 23, further comprising a power amplifier, wherein a first radio interface of the plurality of radio interfaces employs a WCDMA system and a second radio interface of the plurality of radio interfaces employs a Global System for Mobile communications (GSM) system and wherein the direct-conversion transmitter is part of a transceiver that comprises a direct-conversion receiver and wherein the power amplifier is also part of a transmit path common to the plurality of radio interfaces.

25. The direct-conversion transmitter of claim 22, wherein a first radio interface of the plurality of radio interfaces employs a WCDMA system and a second radio interface of the plurality of radio interfaces employs a Global System for Mobile communications (GSM) system.

26. The direct-conversion transmitter of claim 22, wherein the direct-conversion transmitter is part of a transceiver that comprises a direct-conversion receiver.

27. The direct-conversion transmitter of claim 22, wherein the controllable low-pass filter and the controllable gain transmitter amplifier are part of a transmit path common to the plurality of radio interfaces.

28. The direct-conversion transmitter of claim 22, wherein a first radio interface of the plurality of radio interfaces employs a WCDMA system and a second radio interface of the plurality of radio interfaces employs a Global System for Mobile communications (GSM) system, and wherein the controllable low-pass filter and the mixer are part of a transmit path common to the plurality of radio interfaces.

29. The direct-conversion transmitter of claim 22, wherein the controllable low-pass filter and the mixer are part of a transmit path common to the plurality of radio interfaces and wherein a first radio interface of the plurality of radio interfaces employs a WCDMA system and a second radio interface of the plurality of radio interfaces employs a Global System for Mobile communications (GSM) system and wherein the direct-conversion transmitter is part of a transceiver that comprises a direct-conversion receiver.

30. The direct-conversion transmitter of claim 22, further comprising an antenna, wherein the antenna and the mixer are common to the plurality of radio interfaces.

31. The direct-conversion transmitter of claim 30, wherein a first radio interface of the plurality of radio interfaces employs a WCDMA system and a second radio interface of the plurality of radio interfaces employs a Global System for Mobile communications (GSM) system and wherein the direct-conversion transmitter is part of a transceiver that comprises a direct-conversion receiver.

32. The direct-conversion transmitter of claim 31, wherein a power amplifier and a digital to analog converter are common to the plurality of radio interfaces.

33. The direct-conversion transmitter of claim 30, further comprising a power amplifier configured to amplify the carrier-frequency signal amplified by the controllable gain transmitter amplifier, the power amplifier having a controllable operating frequency band set according to which one of the plurality of radio interfaces is selected.

34. The direct-conversion transmitter of claim 22, further comprising a digital-to-analog converter, wherein the digital-to-analog converter and the mixer are common to the plurality of radio interfaces and wherein a first radio interface of the plurality of radio interfaces employs a WCDMA system and a second radio interface of the plurality of radio interfaces employs a Global System for Mobile communications (GSM) system and wherein the direct-conversion transmitter is part of a transceiver that comprises a direct-conversion receiver.

35. The direct-conversion transmitter of claim 2, wherein the controllable gain transmitter amplifier is configured to perform automatic gain control.

36. The direct-conversion transmitter of claim 2, wherein at least two of the plurality of the radio interfaces of the direct-conversion transmitter have different transmission frequencies.

37. The direct-conversion transmitter of claim 2, wherein at least two of the plurality of the radio interfaces of the direct-conversion transmitter have different transmission frequency ranges.

38. The direct-conversion transmitter of claim 2, wherein at least two of the plurality of the radio interfaces of the direct-conversion transmitter have overlapping transmission frequency ranges.

39. The direct-conversion transmitter of claim 2, wherein at least two of the plurality of the radio interfaces of the direct conversion direct-conversion transmitter have transmission frequency ranges that are the same.

40. The direct-conversion transmitter of claim 2, wherein at least two of the plurality of the radio interfaces of the direct-conversion transmitter have adjacent transmission frequency ranges.

41. The direct-conversion transmitter of claim 2, wherein a first radio interface of the plurality of radio interfaces of the direct-conversion transmitter operates at a first transmission frequency, wherein a second radio interface of the plurality of the radio interfaces of the direct-conversion transmitter operates at a second transmission frequency, and wherein the first transmission frequency and the second transmission frequency are within 100 MHz of each other.

42. The direct-conversion transmitter of claim 2, wherein a separation of respective transmission frequencies of at least two of the plurality of radio interfaces ranges from 0 MHz to 1156 MHz.

43. The direct-conversion transmitter of claim 2, wherein a first transmission frequency of the at least one of the plurality of radio interfaces of the direct-conversion transmitter and a second transmission frequency of the at least one other of the plurality of radio interfaces of the direct-conversion transmitter differ by 91 MHz to 132 MHz.

44. The direct-conversion transmitter of claim 2, wherein a first radio interface of the plurality of radio interfaces employs a time division multiple access method and a second radio interface of the plurality of radio interfaces employs a code division multiple access method.

45. The direct-conversion transmitter of claim 2, wherein a first radio interface of the plurality of radio interfaces employs a WCDMA system and a second radio interface of the plurality of radio interfaces employs a Global System for Mobile communications (GSM) system.

46. The direct-conversion transmitter of claim 2, wherein the direct-conversion transmitter is part of a transceiver that comprises a direct-conversion receiver.

47. The direct-conversion transmitter of claim 2, wherein the plurality of radio interfaces further differ from each other by multiple access method.

48. The direct-conversion transmitter of claim 2, wherein the plurality of radio interfaces further differ from each other by duplex method.

49. The direct-conversion transmitter of claim 2, wherein the plurality of radio interfaces further differ from each other by RF bandwidth.

50. The direct-conversion transmitter of claim 2, further comprising a control block circuit configured to generate at least one control signal that indicates which of the plurality of radio interfaces is selected, wherein the control block circuit comprises a microprocessor.

51. The direct-conversion transmitter of claim 2, wherein the carrier-frequency signal comprises a signal from the mixing signal components mixed with the analog baseband transmission signal filtered by the controllable low-pass filter.

52. The direct-conversion transmitter of claim 2, wherein the controllable gain transmitter amplifier is configured to amplify the carrier-frequency signal through a signal path that is common to each of the plurality of radio interfaces.

53. The direct-conversion transmitter of claim 2, wherein the controllable low-pass filter is configured to filter the analog baseband transmission signal through a signal path that is common to each of the plurality of radio interfaces.

54. The direct-conversion transmitter of claim 2, wherein the controllable low-pass filter and the controllable gain transmitter amplifier are part of a transmit path common to the plurality of radio interfaces.

55. The direct-conversion transmitter of claim 2, further comprising the mixer wherein the mixer is configured to generate the carrier-frequency signal from the two mixing signal components and the analog baseband transmission signal filtered by the controllable low-pass filter.

56. The direct-conversion transmitter of claim 55, wherein the mixer is configured to generate the carrier-frequency signal through a signal path that is common to each of the plurality of radio interfaces.

57. The direct-conversion transmitter of claim 55, wherein the controllable low-pass filter and the mixer are part of a transmit path common to the plurality of radio interfaces.

58. The direct-conversion transmitter of claim 55, wherein the mixer is part of a transmit path common to the plurality of radio interfaces.

59. The direct-conversion transmitter of claim 55, further comprising an antenna, wherein the controllable low-pass filter and the mixer are part of a transmit path common to the plurality of radio interfaces.

60. The direct-conversion transmitter of claim 55, wherein the mixer is common to the plurality of radio interfaces.

61. The direct-conversion transmitter of claim 55, further comprising a power amplifier, wherein the mixer and the power amplifier are common to the plurality of radio interfaces.

62. The direct-conversion transmitter of claim 55, further comprising a digital-to-analog converter, wherein the digital-to-analog converter and the mixer are common to the plurality of radio interfaces.

63. The direct-conversion transmitter of claim 2, further comprising a power amplifier, an antenna, and a digital-to-analog converter, wherein the digital-to-analog converter, the power amplifier, the antenna, and the mixer are common to the plurality of radio interfaces.

64. The direct-conversion transmitter of claim 2, further comprising a bandpass filter and a digital-to-analog converter, wherein the digital-to-analog converter, the mixer, and the bandpass filter are common to the plurality of radio interfaces, and wherein a first radio interface of the plurality of radio interfaces employs a WCDMA system and a second

radio interface of the plurality of radio interfaces employs a Global System for Mobile communications (GSM) system and wherein the direct-conversion transmitter is part of a transceiver that comprises a direct-conversion receiver.

65. The direct-conversion transmitter of claim 2, further comprising a digital-to-analog converter, wherein the digital-to-analog converter and the mixer are common to the plurality of radio interfaces and wherein a first radio interface of the plurality of radio interfaces employs a WCDMA system and a second radio interface of the plurality of radio interfaces employs a Global System for Mobile communications (GSM) system and wherein the direct-conversion transmitter is part of a transceiver that comprises a direct-conversion receiver.

66. The direct-conversion transmitter of claim 2, wherein a power amplifier is common to the plurality of radio interfaces.

67. The direct-conversion transmitter of claim 2, further comprising a power amplifier configured to amplify the carrier-frequency signal amplified by the controllable gain transmitter amplifier, the power amplifier having a controllable operating frequency band set according to which one of the plurality of radio interfaces is selected.

68. The direct-conversion transmitter of claim 2, further comprising a digital signal processor (DSP) and a digital-to-analog converter, wherein the DSP, the digital-to-analog converter and the mixer are common to the plurality of radio interfaces, wherein a first radio interface of the plurality of radio interfaces employs a WCDMA system and a second radio interface of the plurality of radio interfaces employs a Global System for Mobile communications (GSM) system, and wherein the direct-conversion transmitter is part of a transceiver that comprises a direct-conversion receiver.

69. The direct-conversion transmitter of claim 2, further comprising a digital-to-analog converter, wherein the digital-to-analog converter, the controllable low-pass filter and the mixer are part of a transmit path common to the plurality of radio interfaces.

70. A transceiver configured to employ direct conversion in both the transmission and reception of RF signals associated with different radio interfaces of communication systems, comprising

means for generating a digital baseband quadrature signal on the basis of the information signal to be transmitted, digital-to-analog converter means for converting the digital baseband transmission signal to analog,

synthesizer,

a controllable frequency divider for dividing a frequency of an output signal generated by the synthesizer to produce a TX mixing signal, wherein the number by which the frequency divider divides the synthesizer output signal depends on the selected transmit frequency band, so that the frequency corresponds to the selected transmission frequency, and wherein 90-degree phase-shifted components of the TX mixing signal are produced as quotients generated already in the frequency divider, wherein said frequency division is a division at least by two, so that a synthesizer operating frequency is used which is a multiple of the highest system frequency,

mixing means for producing a signal at a carrier frequency from the analog baseband transmission signal by means of the TX mixing signal,

characterised in that the transceiver further comprises

a low-pass filter means for filtering the analog baseband transmission signal, the cut-off frequency of the low-pass filter means being controllable so as to correspond to the specifications of the radio interface selected,

controllable gain transmitter amplifier configured to amplify a carrier frequency signal destined to be amplified by a power amplifier and transmitted by an antenna means,

and wherein in a direct conversion transmitter portion of the transceiver, the controllable gain transmit amplifier and the controllable low pass filter means are configured to process transmit signals associated with different radio interfaces.

71. A direct-conversion transmitter comprising:

a transmit synthesizer common to a plurality of radio interfaces of the direct-conversion transmitter and configured to generate a mixing signal;

a controllable low-pass filter common to the plurality of radio interfaces of the direct-conversion transmitter, the controllable low-pass filter configured to perform filtering of an analog baseband transmission signal using a controllable cut-off frequency according to which one of the plurality of radio interfaces of the direct-conversion transmitter is selected;

a frequency divider common to the plurality of radio interfaces of the direct-conversion transmitter and configured to divide a frequency of the mixing signal at least by two, wherein the dividing produces two mixing signal components having a 90-degree phase difference; and

a controllable gain transmitter amplifier common to the plurality of radio interfaces of the direct-conversion transmitter and configured to amplify a carrier-frequency signal from a mixer at a gain controlled according to which one of the plurality of radio interfaces of the direct-conversion transmitter is selected, wherein at least one of the plurality of radio interfaces of the direct-conversion transmitter comprises a channel spacing and a channel bit rate that at least one other of the plurality of radio interfaces does not have.

72. The direct-conversion transmitter of claim 71, wherein a power amplifier is common to the plurality of radio interfaces.

73. The direct-conversion transmitter of claim 71, wherein the controllable gain transmitter amplifier is configured to perform automatic gain control.

74. The direct-conversion transmitter of claim 71, wherein at least two of the plurality of the radio interfaces of the direct-conversion transmitter have different transmission frequencies.

75. The direct-conversion transmitter of claim 71, wherein at least two of the plurality of the radio interfaces of the direct-conversion transmitter have different transmission frequency ranges.

76. The direct-conversion transmitter of claim 71, wherein at least two of the plurality of the radio interfaces of the direct-conversion transmitter have overlapping transmission frequency ranges.

77. The direct-conversion transmitter of claim 71, wherein at least two of the plurality of the radio interfaces of the direct-conversion transmitter have transmission frequency ranges that are the same.

78. The direct-conversion transmitter of claim 71, wherein at least two of the plurality of the radio interfaces of the direct-conversion transmitter have adjacent transmission frequency ranges.

79. The direct-conversion transmitter of claim 71, wherein a first radio interface of the plurality of radio interfaces of the direct-conversion transmitter operates at a first transmission frequency, wherein a second radio interface of the plurality of the radio interfaces of the direct-conversion transmitter operates at a second transmission frequency, and wherein the first

transmission frequency and the second transmission frequency are within 100 MHz of each other.

80. The direct-conversion transmitter of claim **71**, wherein a first radio interface of the plurality of radio interfaces employs a time division multiple access method and a second radio interface of the plurality of radio interfaces employs a code division multiple access method.

81. The direct-conversion transmitter of claim **71**, wherein a first radio interface of the plurality of radio interfaces employs at least one different multiple access method than a second radio interface of the plurality of radio interfaces.

82. The direct-conversion transmitter of claim **81**, wherein the first and second radio interfaces further differ from each other by at least duplex method.

83. The direct-conversion transmitter of claim **82**, wherein the direct-conversion transmitter is part of a transceiver that comprises a direct-conversion receiver.

84. The direct-conversion transmitter of claim **83**, wherein the controllable low-pass filter and the mixer are part of a transmit path common to the plurality of radio interfaces.

85. The direct-conversion transmitter of claim **84**, wherein a power amplifier is common to the plurality of radio interfaces.

86. The direct-conversion transmitter of claim **71**, further comprising a control block circuit configured to generate at least one control signal that indicates which of the plurality of radio interfaces is selected, wherein the control block circuit comprises a microprocessor.

87. The direct-conversion transmitter of claim **71**, wherein a first radio interface of the plurality of radio interfaces employs a WCDMA system and a second radio interface of the plurality of radio interfaces employs a Global System for Mobile communications (GSM) system.

88. The direct-conversion transmitter of claim **87**, wherein the direct-conversion transmitter is part of a transceiver that comprises a direct-conversion receiver.

89. The direct-conversion transmitter of claim **71**, wherein the direct-conversion transmitter is part of a transceiver that comprises a direct-conversion receiver.

90. The direct-conversion transmitter of claim **71**, wherein the plurality of radio interfaces further differ from each other by at least one multiple access method.

91. The direct-conversion transmitter of claim **90**, wherein the direct-conversion transmitter is part of a transceiver that comprises a direct-conversion receiver.

92. The direct-conversion transmitter of claim **90**, wherein the plurality of radio interfaces further differ from each other by at least duplex method.

93. The direct-conversion transmitter of claim **90**, wherein the direct-conversion transmitter is part of a transceiver that comprises a direct-conversion receiver.

94. The direct-conversion transmitter of claim **71**, wherein the plurality of radio interfaces further differ from each other by at least duplex method.

95. The direct-conversion transmitter of claim **94**, wherein the direct-conversion transmitter is part of a transceiver that comprises a direct-conversion receiver.

96. The direct-conversion transmitter of claim **71**, wherein a first radio interface of the plurality of radio interfaces employs a different number of channels than is employed by a second radio interface of the plurality of radio interfaces.

97. The direct-conversion transmitter of claim **71**, wherein the plurality of radio interfaces further differ from each other by at least RF bandwidth.

98. The direct-conversion transmitter of claim **71**, wherein the carrier-frequency signal comprises a signal from the mix-

ing signal components mixed with the analog baseband transmission signal filtered by the controllable low-pass filter.

99. The direct-conversion transmitter of claim **71**, wherein the controllable low-pass filter is configured to filter the analog baseband transmission signal through a signal path that is common for each of the plurality of radio interfaces.

100. The direct-conversion transmitter of claim **71**, wherein the controllable low-pass filter and the controllable gain transmitter amplifier are part of a transmit path common to the plurality of radio interfaces.

101. The direct-conversion transmitter of claim **71**, wherein the controllable low-pass filter and the mixer are part of a transmit path common to the plurality of radio interfaces.

102. The direct-conversion transmitter of claim **101**, wherein the direct-conversion transmitter is part of a transceiver that comprises a direct-conversion receiver.

103. The direct-conversion transmitter of claim **102**, wherein the plurality of radio interfaces further differ from each other by at least one multiple access method.

104. The direct-conversion transmitter of claim **103**, further comprising a power amplifier, wherein the power amplifier is common to the plurality of radio interfaces.

105. The direct-conversion transmitter of claim **71**, further comprising the mixer, wherein the controllable low-pass filter, the mixer, and the controllable gain transmitter amplifier are part of a transmit path common to the plurality of radio interfaces.

106. The direct-conversion transmitter of claim **71**, further comprising the mixer, wherein the mixer is common to the plurality of radio interfaces.

107. The direct-conversion transmitter of claim **71**, wherein the mixer is common to the plurality of radio interfaces.

108. The direct-conversion transmitter of claim **71**, further comprising the mixer and a power amplifier, wherein the and the power amplifier are common to the plurality of radio interfaces.

109. The direct-conversion transmitter of claim **71**, further comprising a power amplifier, wherein the controllable low-pass filter, the mixer, the power amplifier, and the controllable gain transmitter amplifier are part of a transmit path common to the plurality of radio interfaces.

110. The direct-conversion transmitter of claim **109**, wherein the direct-conversion transmitter is part of a transceiver that comprises a direct-conversion receiver.

111. The direct-conversion transmitter of claim **71**, further comprising a bandpass filter and an antenna, wherein the antenna and the bandpass filter are common for the plurality of radio interfaces.

112. The direct-conversion transmitter of claim **71**, further comprising an antenna and a digital-to-analog converter, wherein the antenna, the digital-to-analog converter, and the mixer are common to the plurality of radio interfaces.

113. The direct-conversion transmitter of claim **112**, wherein a power amplifier is common to the plurality of radio interfaces.

114. The direct-conversion transmitter of claim **113**, wherein a digital signal processor (DSP) is common to the plurality of radio interfaces.

115. The direct-conversion transmitter of claim **113**, wherein a bandpass filter is common to the plurality of radio interfaces.

116. The direct-conversion transmitter of claim **71**, further comprising an antenna, wherein the antenna, the controllable low-pass filter, the mixer, and the controllable gain transmitter amplifier are part of a transmit path common to the plurality of radio interfaces.

117. The direct-conversion transmitter of claim 71, further comprising a power amplifier and a digital-to-analog converter, wherein the power amplifier, the digital-to-analog converter, the controllable low-pass filter, the mixer, and the controllable gain transmitter amplifier are part of a transmit path common to the plurality of radio interfaces. 5

118. The direct-conversion transmitter of claim 71, further comprising a bandpass filter, a power amplifier, and a digital-to-analog converter, wherein the bandpass filter, the power amplifier, the digital-to-analog converter, the controllable low-pass filter, the mixer, and the controllable gain transmitter amplifier are part of a transmit path common to the plurality of radio interfaces. 10

119. The direct-conversion transmitter of claim 71, wherein the frequency divider is a controllable frequency divider. 15

120. The direct-conversion transmitter of claim 71, wherein the frequency divider is configured to divide the frequency of the mixing signal by different divisors determined according to which one of the plurality of radio interfaces of the direct-conversion transmitter is selected. 20

121. The direct-conversion transmitter of claim 71, wherein the frequency divider is configured to divide the frequency of the mixing signal at least by two and by four.

122. The direct-conversion transmitter of claim 71, wherein the frequency divider comprises a control input that determines a divisor by which the frequency of the mixing signal is divided. 25

* * * * *

UNITED STATES PATENT AND TRADEMARK OFFICE
CERTIFICATE OF CORRECTION

PATENT NO. : 9,270,301 B2
APPLICATION NO. : 14/272820
DATED : February 23, 2016
INVENTOR(S) : Risto Väisänen et al.

Page 1 of 1

It is certified that error appears in the above-identified patent and that said Letters Patent is hereby corrected as shown below:

In the Claims

In Column 8, Claim 1, Line 37

Please delete “one of plurality” and replace with -- one of the plurality --

In Column 11, Claim 13, Line 20

Please delete “claim 2 wherein” and replace with -- claim 2, wherein --

In Column 12, Claim 24, Line 19-20

Please delete “also part of a transmit path common” and replace with -- common --

In Column 13, Claim 39, Line 27-28

Please delete “direct conversion direct-conversion” and replace with -- direct-conversion --

In Column 15, Claim 65, Line 11

Please delete “communications GSM)” and replace with -- communications (GSM) --

In Column 17, Claim 93, Line 50

Please delete “claim 90” and replace with -- claim 92 --

In Column 18, Claim 108, Line 35

Please delete “wherein the and” and replace with -- wherein the mixer and --

Signed and Sealed this
Twenty-third Day of August, 2016



Michelle K. Lee
Director of the United States Patent and Trademark Office