



US009246364B2

(12) **United States Patent**
Brahmavar et al.

(10) **Patent No.:** **US 9,246,364 B2**
(45) **Date of Patent:** **Jan. 26, 2016**

(54) **RADIALLY EMBEDDED PERMANENT MAGNET ROTOR AND METHODS THEREOF**

310/156.53, 156.55–156.57, 216.008,
310/216.011, 216.013, 216.016, 216.096
See application file for complete search history.

(71) Applicant: **Regal Beloit America, Inc.**, Beloit, WI (US)

(56) **References Cited**

(72) Inventors: **Subhash Marutirao Brahmavar**, Fort Wayne, IN (US); **Lester Benjamin Manz**, Paulding, OH (US); **Ludovic Andre Chretien**, Columbia City, IN (US); **Changiz Rashidzadeh**, Yorba Linda, CA (US); **Dan Mircea Ionel**, Fox Point, WI (US)

U.S. PATENT DOCUMENTS

1,298,465 A 3/1919 Dean
2,059,518 A 11/1936 Harley

(Continued)

(73) Assignee: **REGAL BELOIT AMERICA, INC.**, Beloit, WI (US)

FOREIGN PATENT DOCUMENTS

CN 102111025 A 6/2011
CN 102468051 A 5/2012

(Continued)

(*) Notice: Subject to any disclaimer, the term of this patent is extended or adjusted under 35 U.S.C. 154(b) by 88 days.

OTHER PUBLICATIONS

Office Action issued in U.S. Appl. No. 13/652,161 on Mar. 27, 2014.

(Continued)

(21) Appl. No.: **13/652,035**

Primary Examiner — Naishadh Desai

(22) Filed: **Oct. 15, 2012**

(74) *Attorney, Agent, or Firm* — Armstrong Teasdale LLP

(65) **Prior Publication Data**

(57) **ABSTRACT**

US 2014/0103768 A1 Apr. 17, 2014

In one embodiment, a permanent magnet rotor is provided. The permanent magnet rotor includes at least one permanent magnet and a substantially cylindrical rotor core including an outer edge and an inner edge defining a central opening. The rotor core includes a radius R, at least one pole, and at least one radial aperture extending radially through the rotor core from the outer edge to a predetermined depth less than the radius. The at least one radial aperture is configured to receive the at least one permanent magnet. The rotor further includes at least one protrusion extending into the at least one radial aperture, the at least one protrusion positioned substantially along a bottom of the at least one radial aperture and configured to facilitate retention of the at least one permanent magnet within the at least one radial aperture.

(51) **Int. Cl.**
H02K 1/27 (2006.01)
H02K 15/03 (2006.01)
H02K 21/16 (2006.01)

(52) **U.S. Cl.**
CPC **H02K 1/2773** (2013.01); **H02K 15/03** (2013.01); **H02K 21/16** (2013.01); **H02K 2201/03** (2013.01); **H02K 2213/03** (2013.01); **Y10T 29/49012** (2015.01)

(58) **Field of Classification Search**
CPC H02K 1/27; H02K 1/2706
USPC 310/156.09, 156.19, 156.36–156.38, 310/156.43, 156.45, 156.47–156.49,

19 Claims, 20 Drawing Sheets

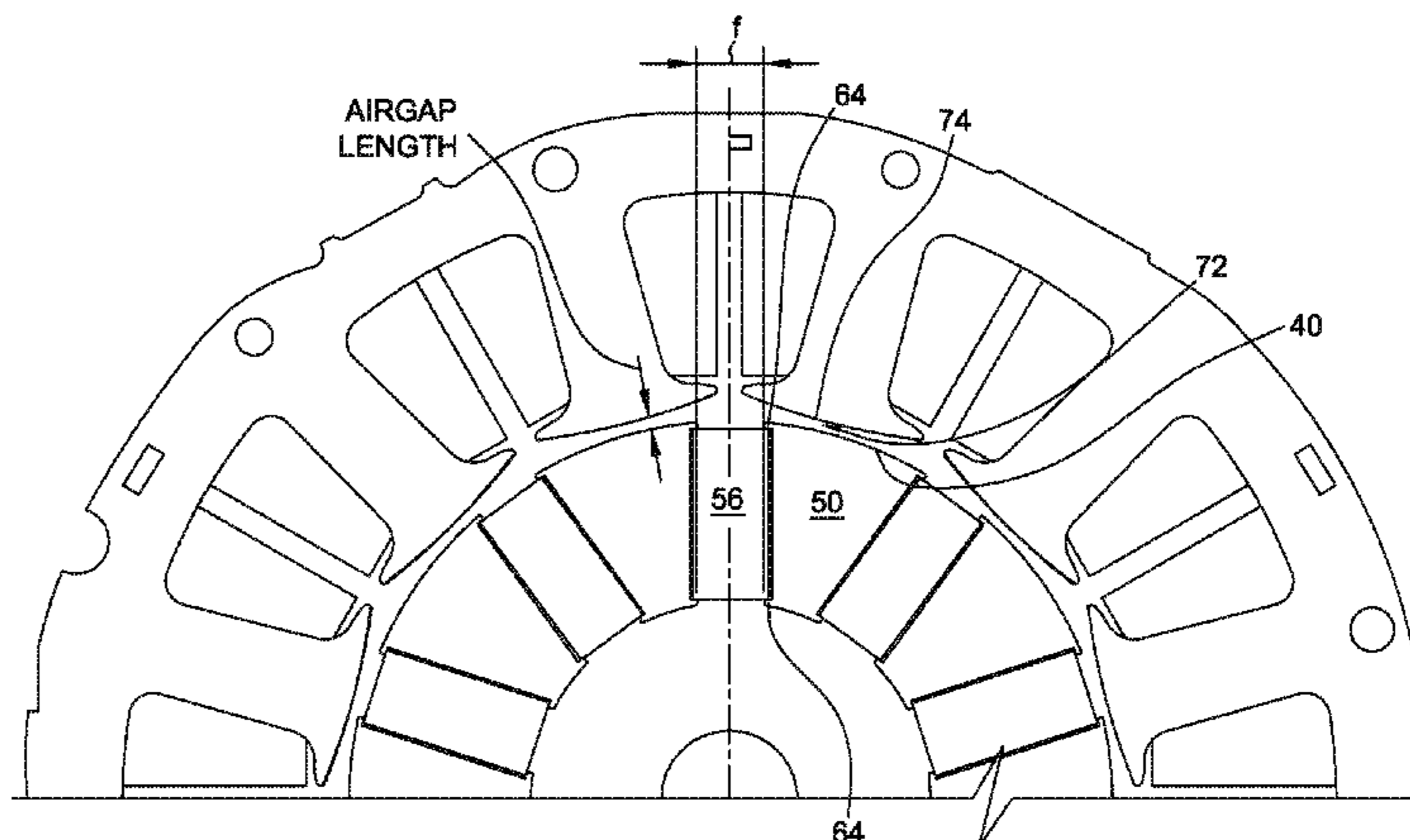
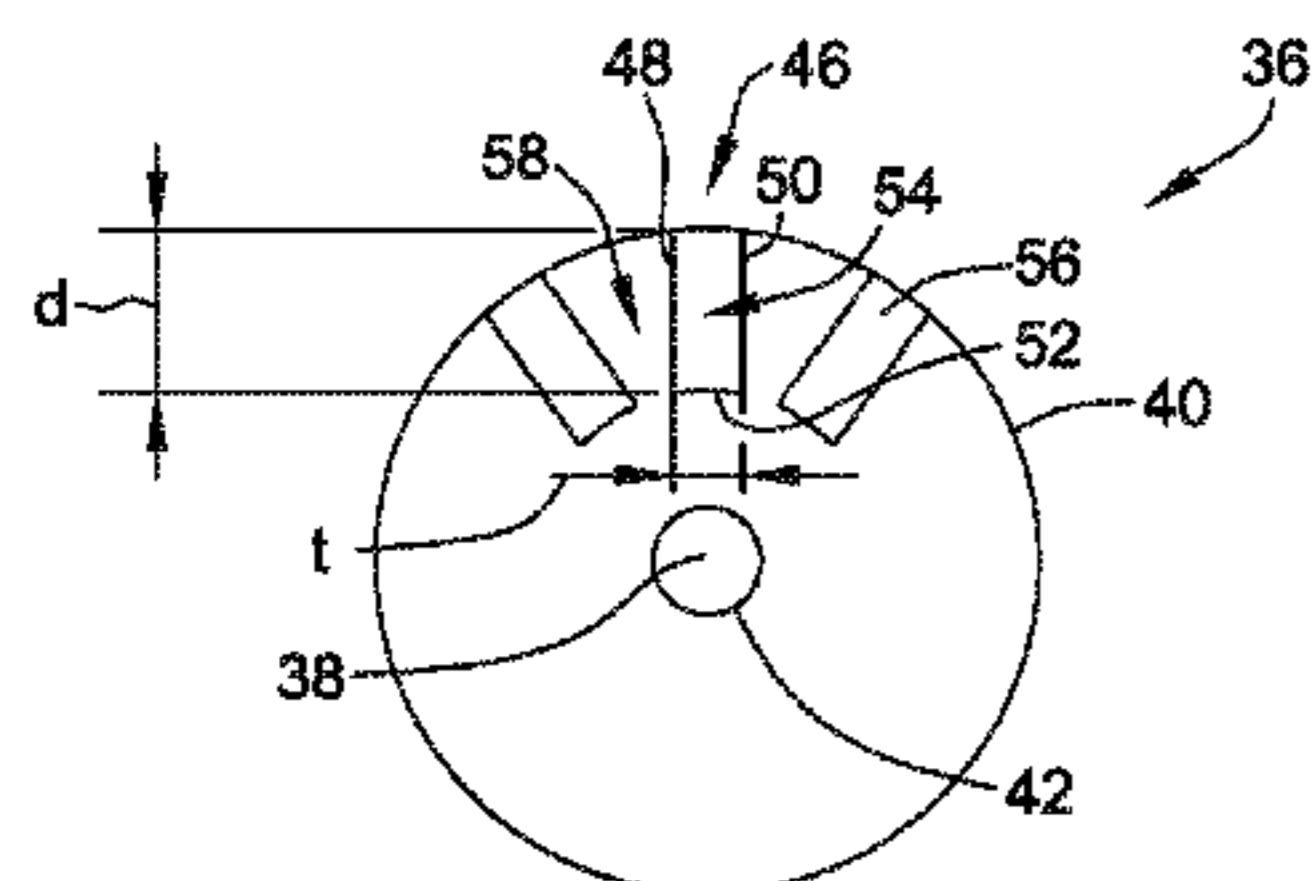

(56)

References Cited

U.S. PATENT DOCUMENTS

2,312,101 A 2/1943 Killam et al.
 2,486,656 A 11/1949 Klinkhamer
 2,794,137 A 5/1957 Faus et al.
 2,927,229 A 3/1960 Merrill
 3,111,596 A 11/1963 Lovegrove
 3,210,582 A 10/1965 Miller
 3,344,325 A 9/1967 Sklaroff
 3,417,295 A 12/1968 Littwin
 3,466,518 A 9/1969 Aylikci et al.
 3,513,341 A 5/1970 Gratzmuller
 3,555,324 A 1/1971 Lovegrove
 3,599,024 A 8/1971 Kitamura
 3,872,334 A 3/1975 Loubier
 3,943,392 A 3/1976 Keuper et al.
 3,950,663 A 4/1976 Mead
 3,979,821 A * 9/1976 Noodleman 29/598
 4,059,898 A 11/1977 Adair
 4,104,787 A 8/1978 Jandeska et al.
 4,143,289 A 3/1979 Williams
 4,327,302 A 4/1982 Hershberger
 4,434,546 A 3/1984 Hershberger
 4,614,888 A 9/1986 Mosher et al.
 4,631,807 A 12/1986 Kawada et al.
 4,658,167 A * 4/1987 Popov et al. 310/156.55
 4,725,750 A 2/1988 Welch
 4,741,094 A 5/1988 Denk et al.
 4,954,736 A 9/1990 Kawamoto et al.
 4,977,344 A 12/1990 Obradovic
 5,010,266 A 4/1991 Uchida
 5,023,502 A 6/1991 Johnson
 5,091,668 A 2/1992 Cuenot et al.
 5,140,211 A 8/1992 Ucida
 5,157,297 A 10/1992 Uchida
 5,200,662 A 4/1993 Tagami et al.
 5,411,608 A 5/1995 Hazelton et al.
 5,500,994 A 3/1996 Itaya
 5,557,248 A 9/1996 Prochazka
 5,645,651 A 7/1997 Fujimura et al.
 5,684,352 A 11/1997 Mita et al.
 5,786,650 A 7/1998 Uchida et al.
 5,786,652 A 7/1998 Gueraud et al.
 5,806,169 A 9/1998 Trago et al.
 5,818,141 A 10/1998 Cho et al.
 5,829,120 A 11/1998 Uchida et al.
 5,889,346 A * 3/1999 Uchida et al. 310/156.57
 5,990,592 A 11/1999 Miura et al.
 6,218,753 B1 4/2001 Asano et al.
 6,265,802 B1 7/2001 Getschmann
 6,340,857 B2 1/2002 Nishiyama et al.
 6,359,366 B1 3/2002 Liang et al.
 6,389,538 B1 5/2002 Gruse et al.
 6,392,324 B1 5/2002 Kuwahara

6,426,576 B1 * 7/2002 Varenne 310/156.09
 6,452,301 B1 9/2002 Van Dine et al.
 6,519,833 B2 2/2003 Futami et al.
 6,657,349 B2 12/2003 Fukushima
 6,674,213 B2 1/2004 Berger
 6,703,741 B1 3/2004 Ifrim
 6,707,209 B2 3/2004 Crapo et al.
 6,785,951 B2 9/2004 Carl, Jr. et al.
 6,794,839 B1 * 9/2004 Maslov et al. 318/400.2
 6,987,342 B2 1/2006 Hans
 7,091,645 B2 8/2006 Yoneda et al.
 7,148,598 B2 12/2006 Ionel et al.
 7,157,827 B2 1/2007 Heideman et al.
 7,332,845 B2 2/2008 Heideman et al.
 7,626,349 B2 12/2009 Marcinkiewicz et al.
 7,800,272 B2 9/2010 Nakayama et al.
 7,868,503 B1 * 1/2011 Nakayama et al. 310/156.56
 8,004,140 B2 8/2011 Alexander et al.
 8,018,110 B2 * 9/2011 Alexander et al. 310/156.56
 8,138,649 B2 * 3/2012 Bradfield 310/156.19
 2003/0052561 A1 3/2003 Rahman et al.
 2003/0214194 A1 11/2003 Carl, Jr. et al.
 2004/0004407 A1 * 1/2004 Laurent et al. 310/156.48
 2004/0124728 A1 7/2004 Yamaguchi et al.
 2004/0245881 A1 * 12/2004 Kadoya et al. 310/185
 2010/0308682 A1 12/2010 Horng et al.
 2011/0115126 A1 5/2011 Matsubayashi et al.
 2011/0127859 A1 6/2011 Amrhein et al.
 2012/0104907 A1 5/2012 Zeng et al.
 2012/0132783 A1 5/2012 Jia
 2012/0139373 A1 6/2012 Jia et al.
 2012/0181895 A1 7/2012 Pan
 2012/0194011 A1 8/2012 Liu et al.

FOREIGN PATENT DOCUMENTS

JP 55133654 A 10/1980
 JP 357186964 A 11/1982
 JP 2002 218683 A 8/2002
 RU EA014510 B1 12/2010
 WO WO 2008113082 A1 * 9/2008 H02K 1/27
 WO WO 2010014844 A2 * 2/2010 H02K 1/27
 WO WO 2010014844 A3 * 7/2010 H02K 1/27
 WO 2011076028 A1 6/2011

OTHER PUBLICATIONS

PowerPoint slides of Broad Ocean Motor (Model BOM ZWK70200550601) dated Sep. 13, 2012.
 Office Action in U.S. Appl. No. 13/652,227 issued Apr. 11, 2014.
 Office Action issued in U.S. Appl. No. 13/652,127 mailed Jan. 23, 2015.
 Notice of Allowance and Fee(s) due mailed May 5, 2015; U.S. Appl. No. 13/652,127, 11 pages.

* cited by examiner

FIG. 1

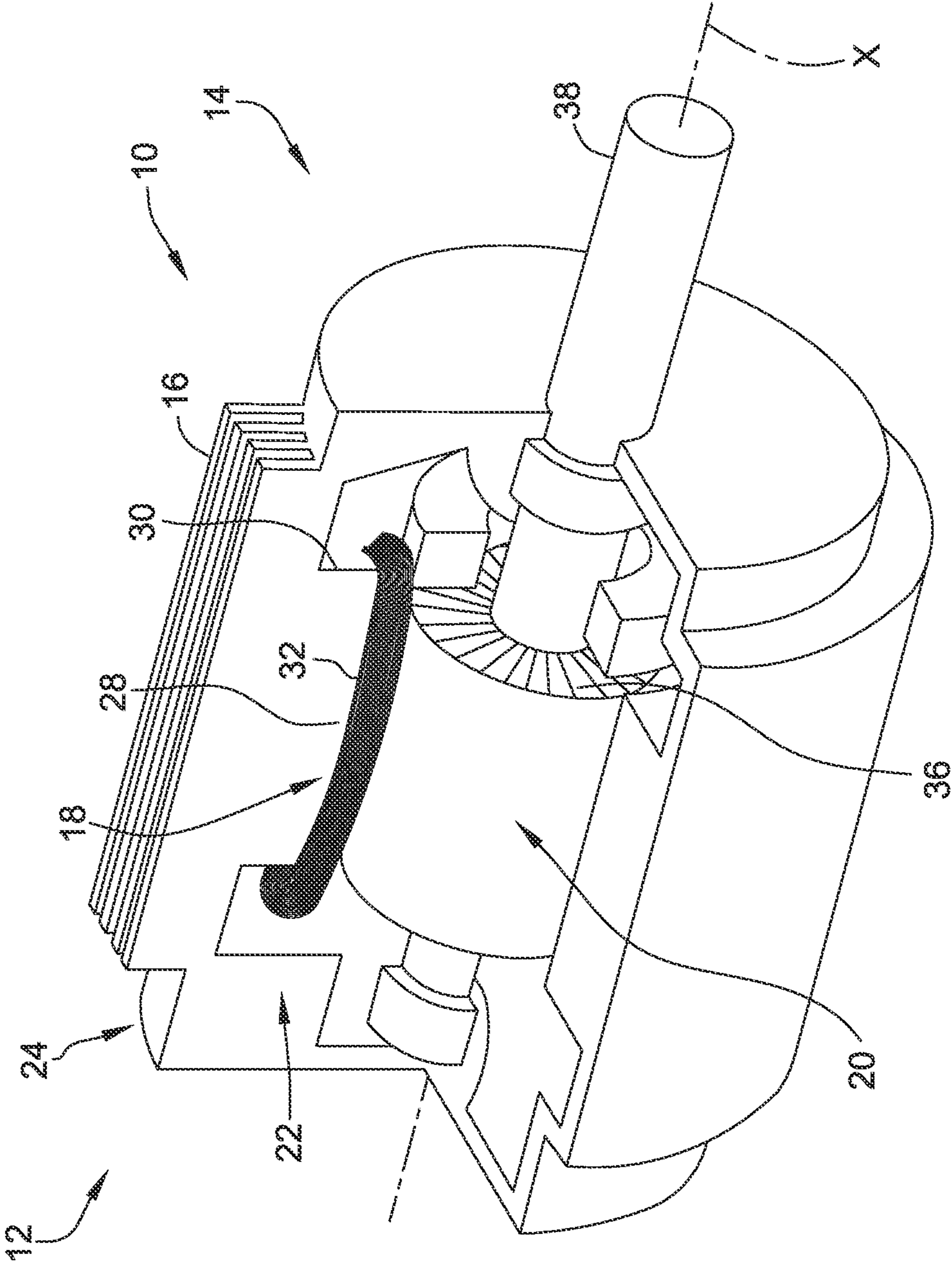

FIG. 2

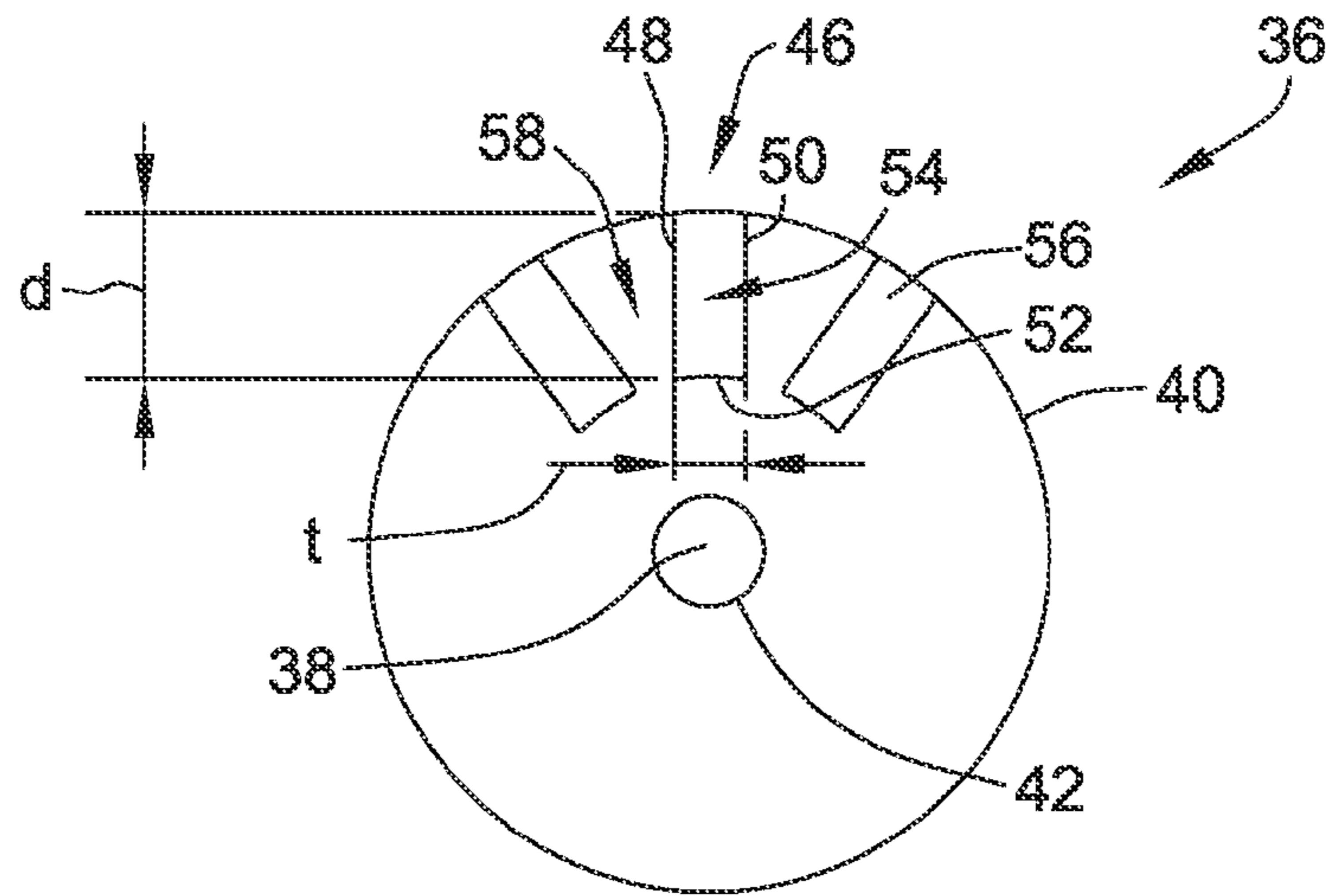

FIG. 3

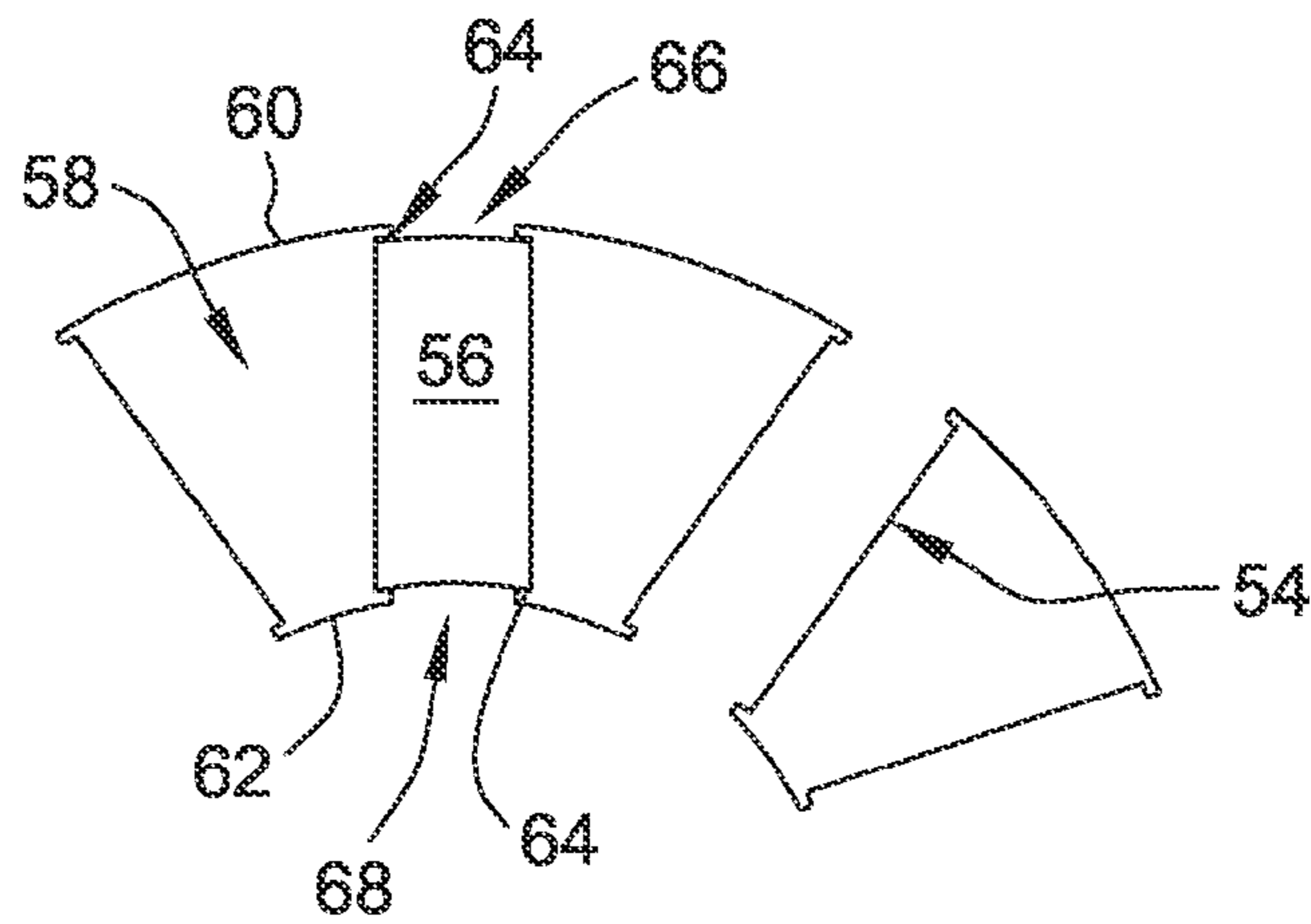
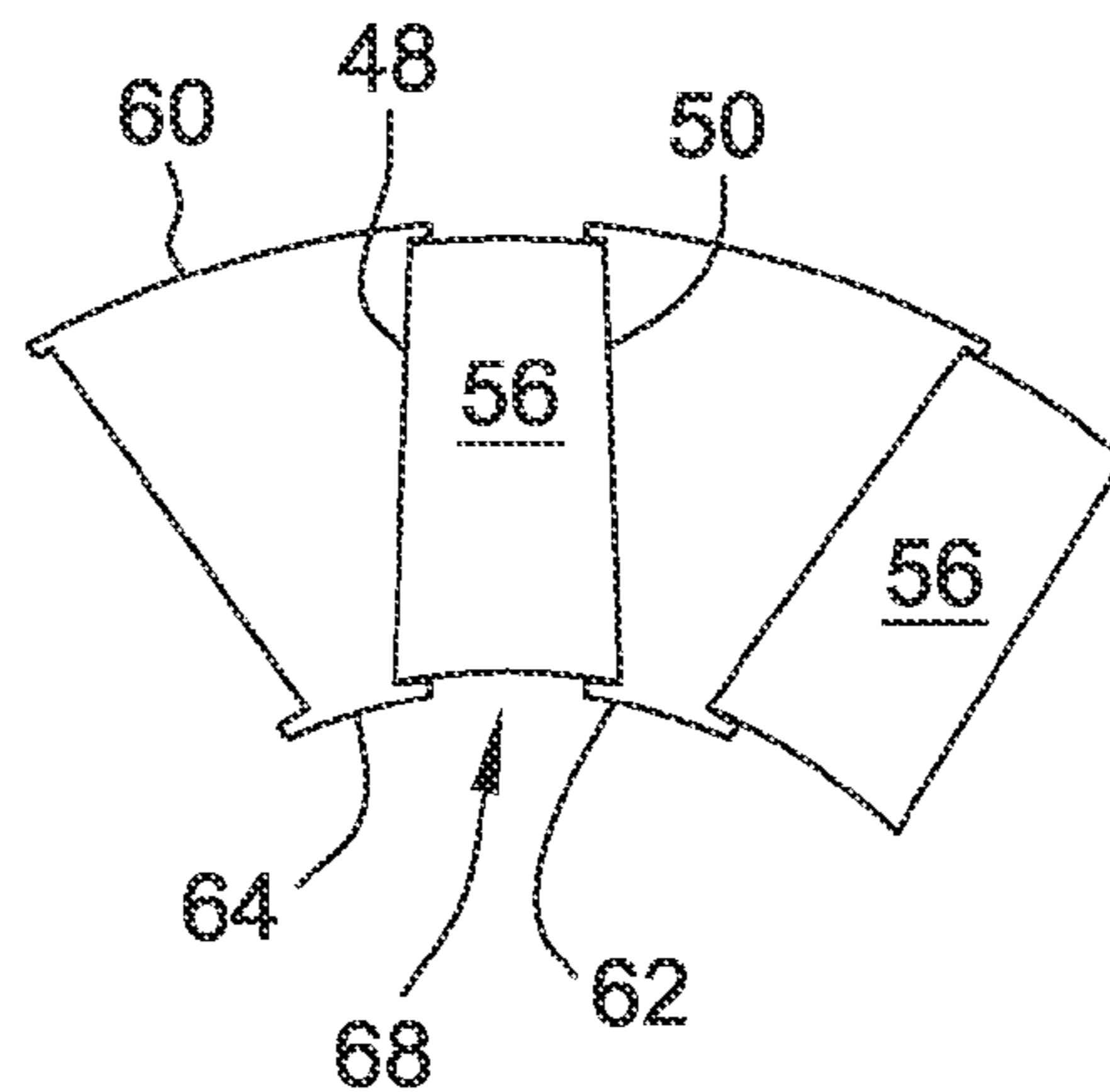

FIG. 4



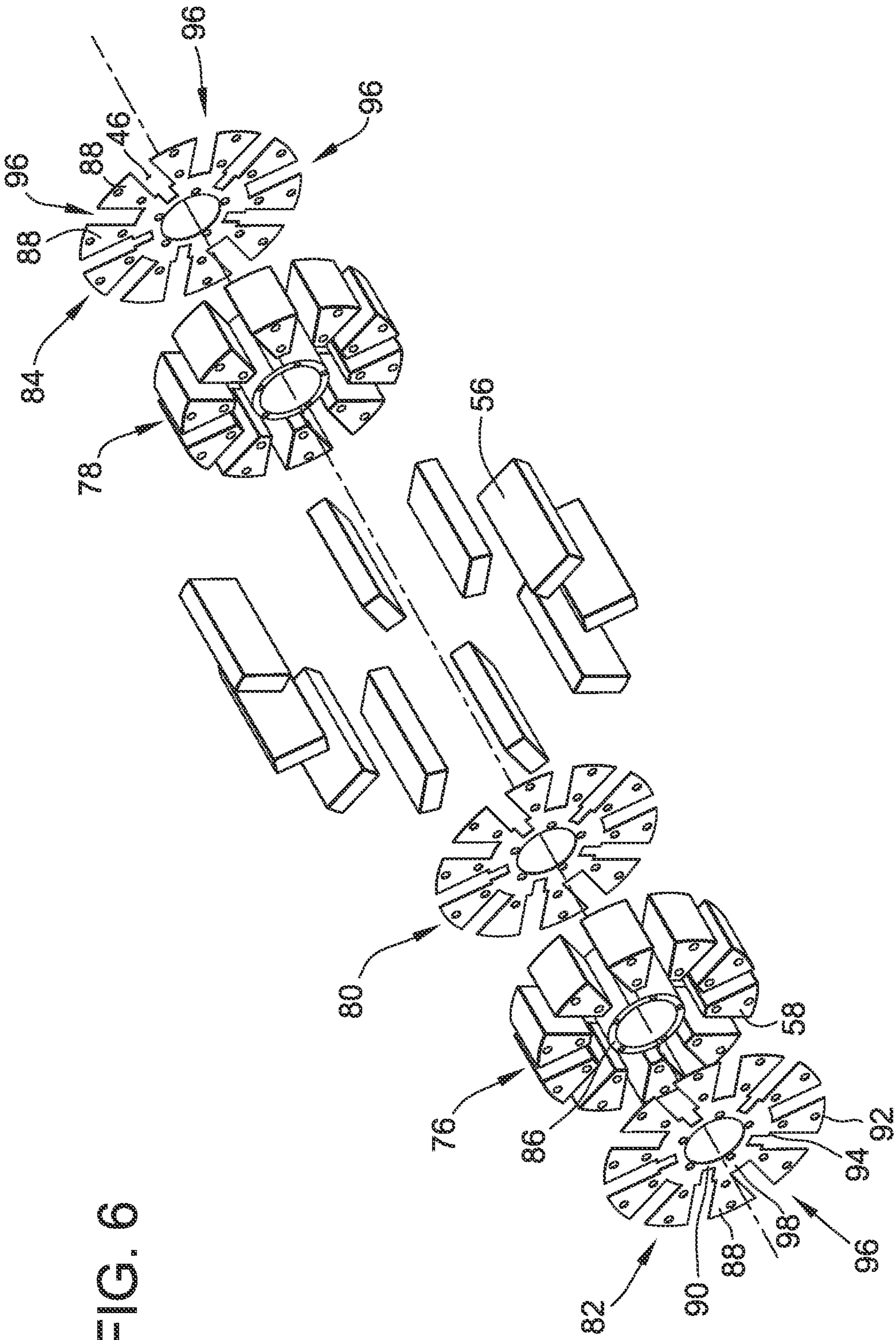

FIG. 6

FIG. 7

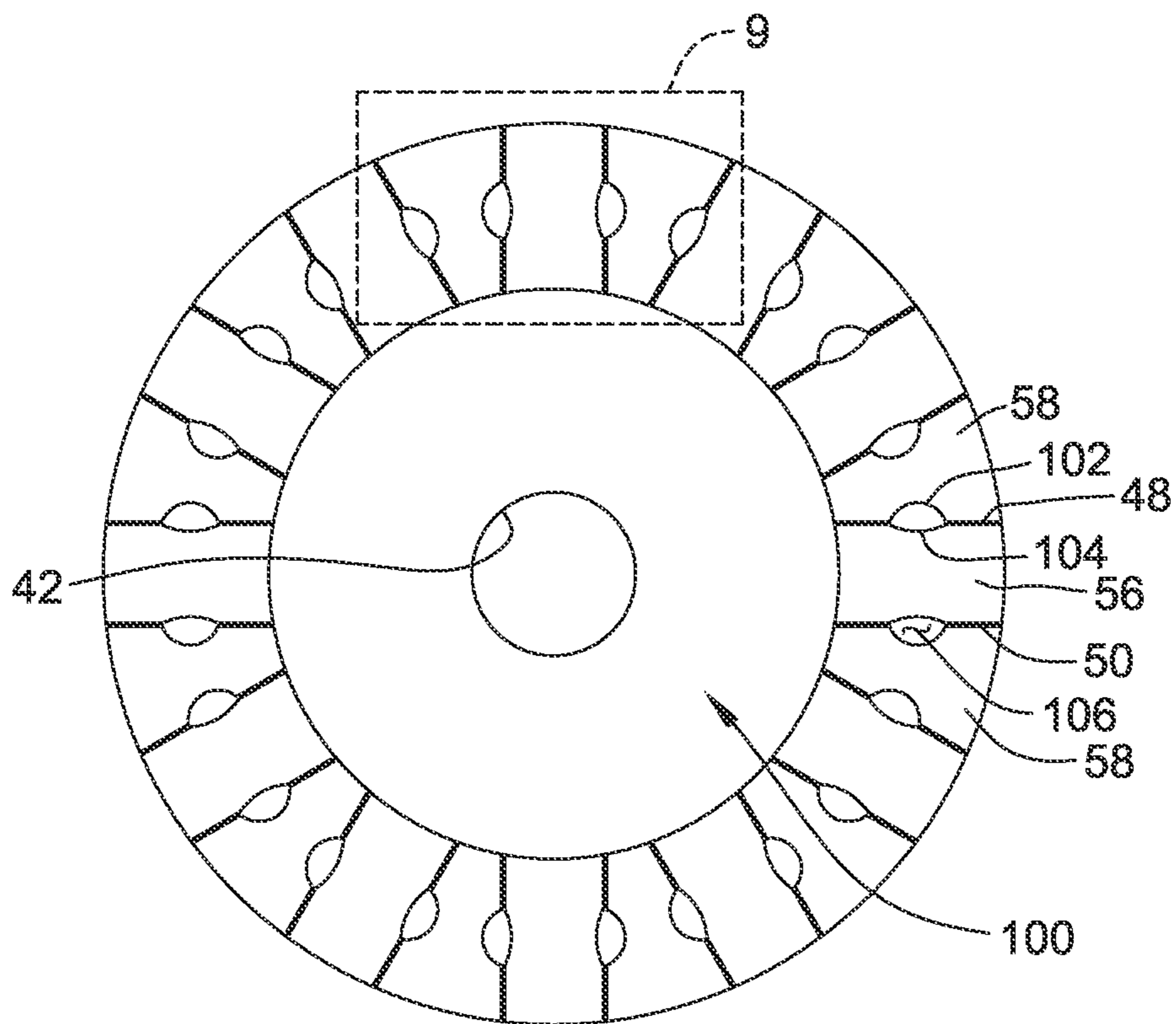

FIG. 8

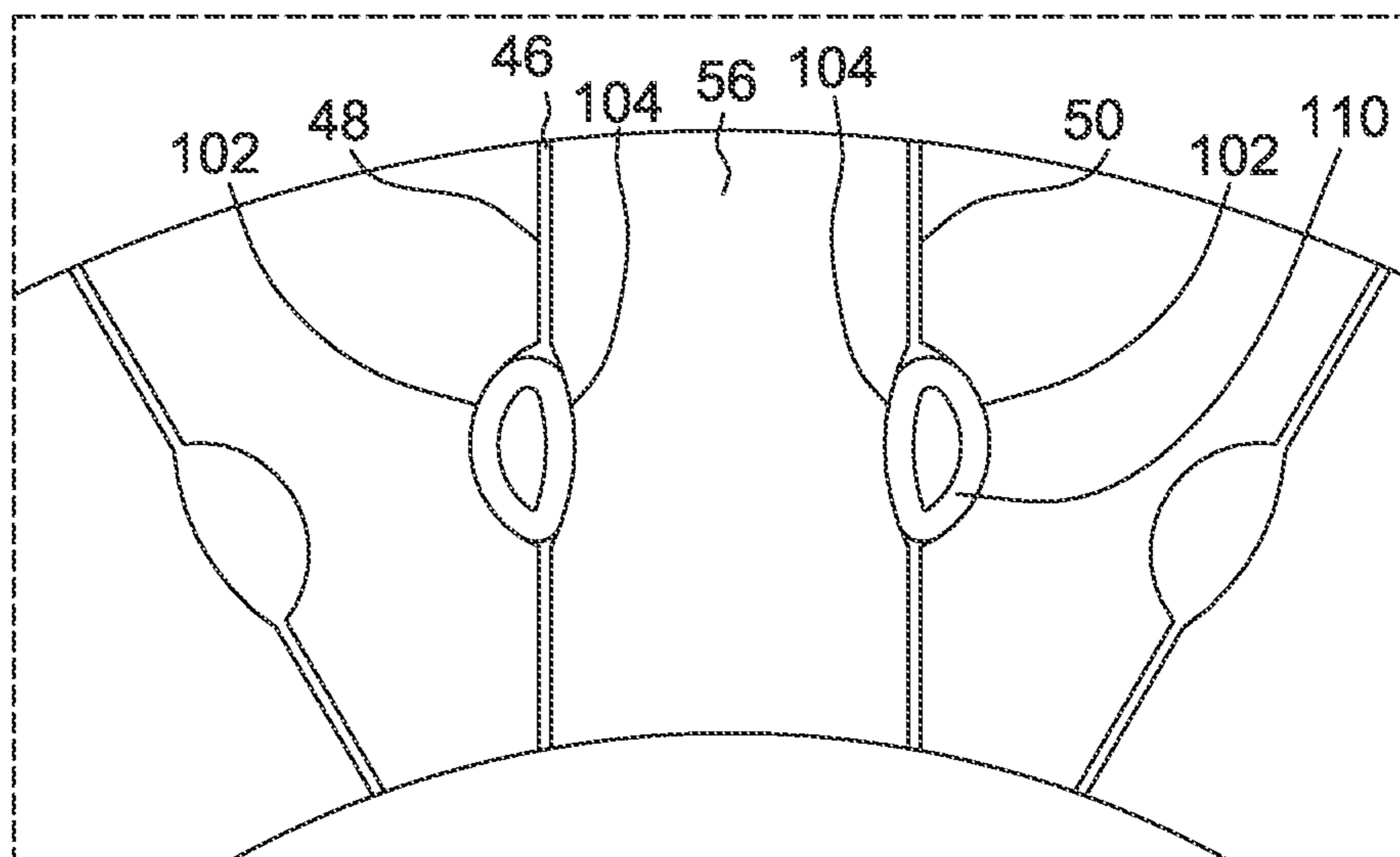
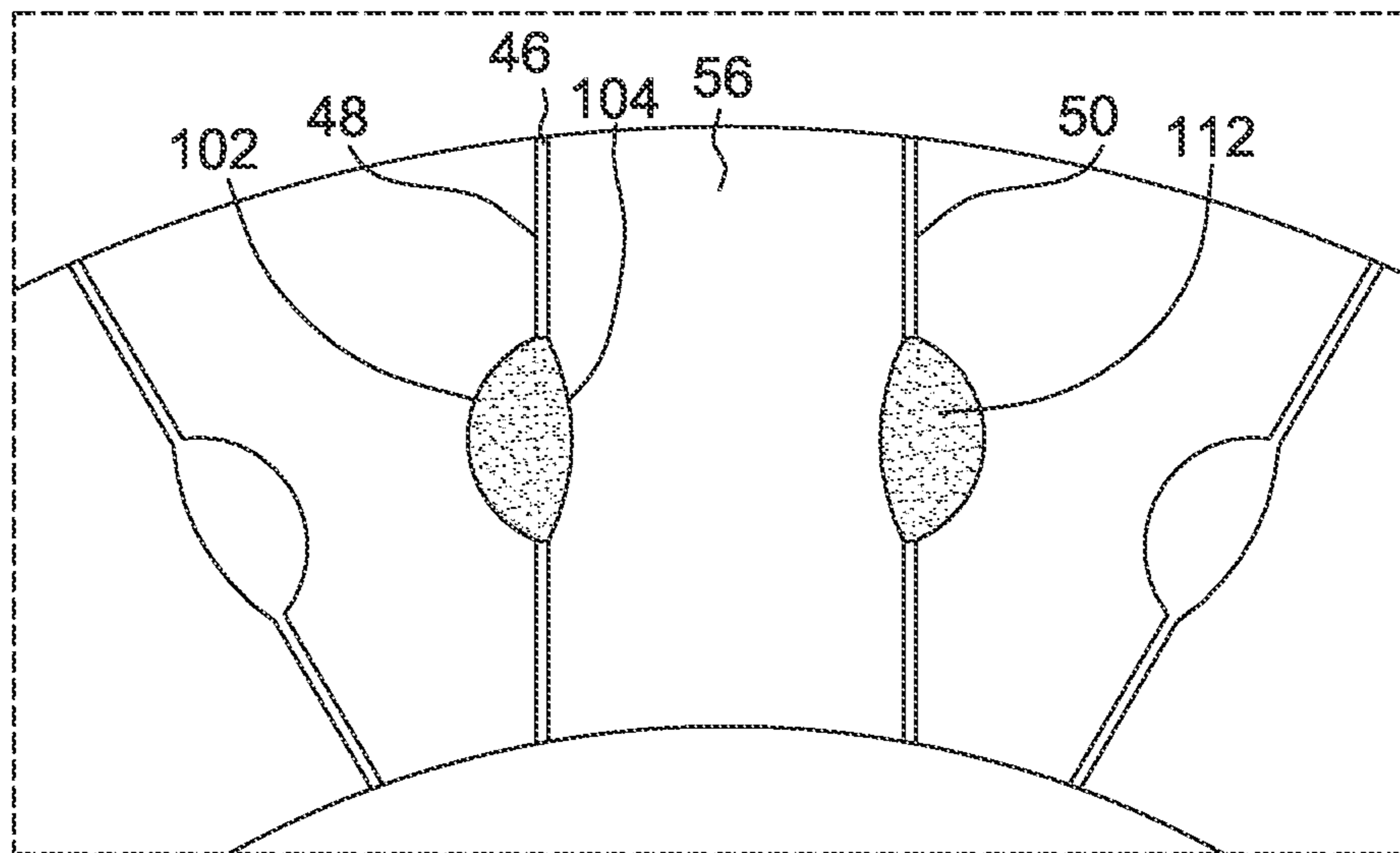

FIG. 9



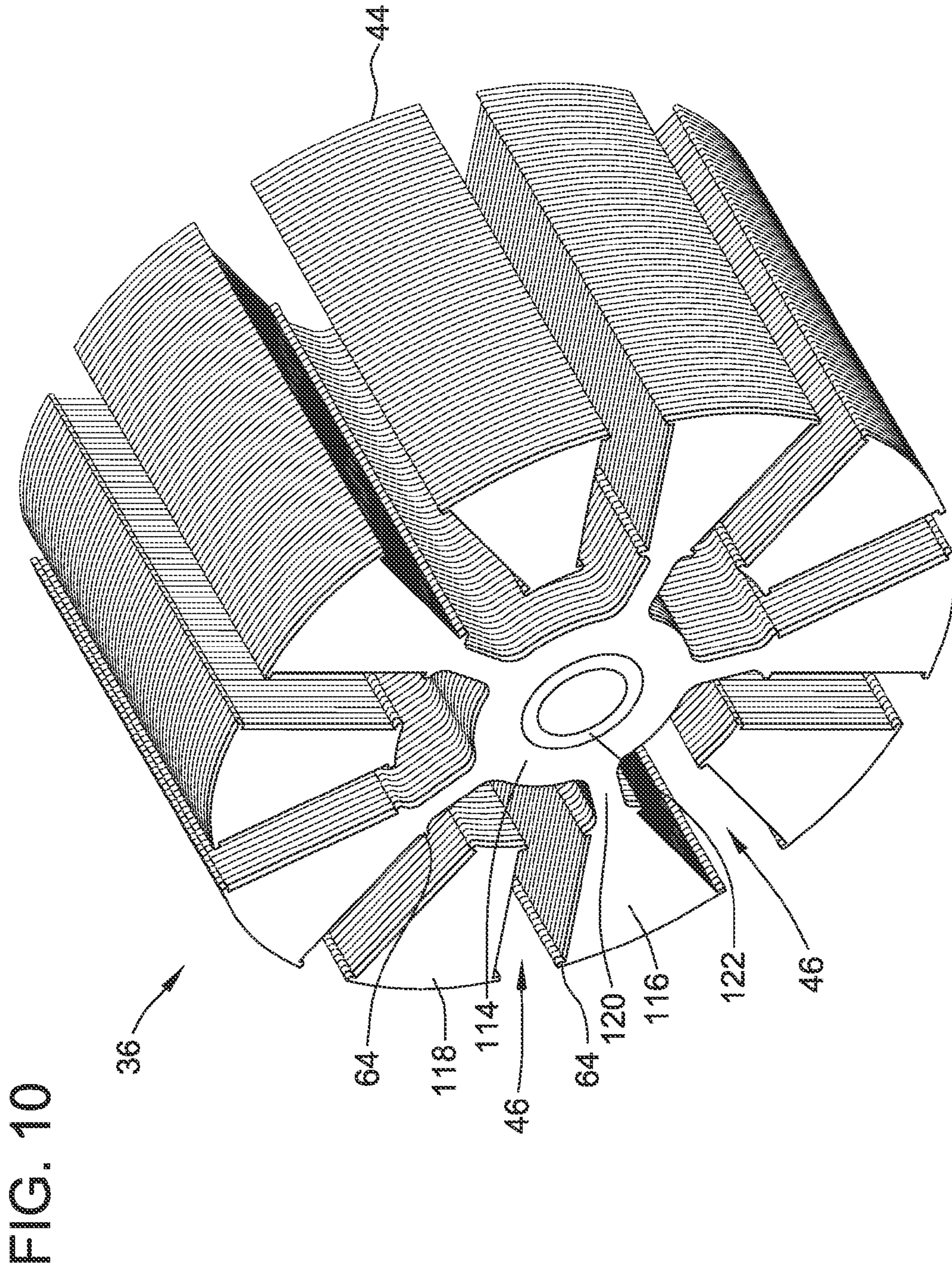

FIG. 11

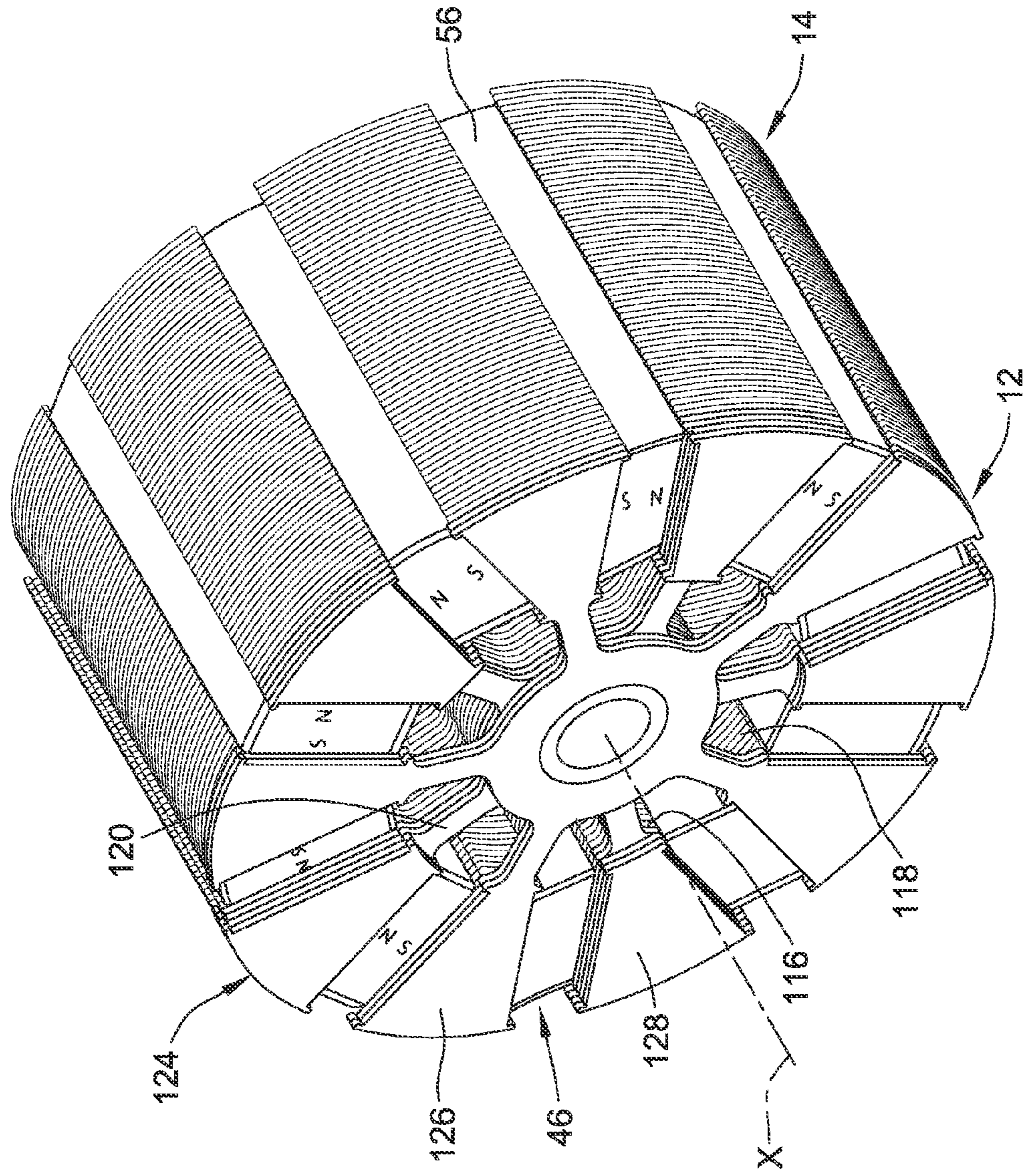

FIG. 12

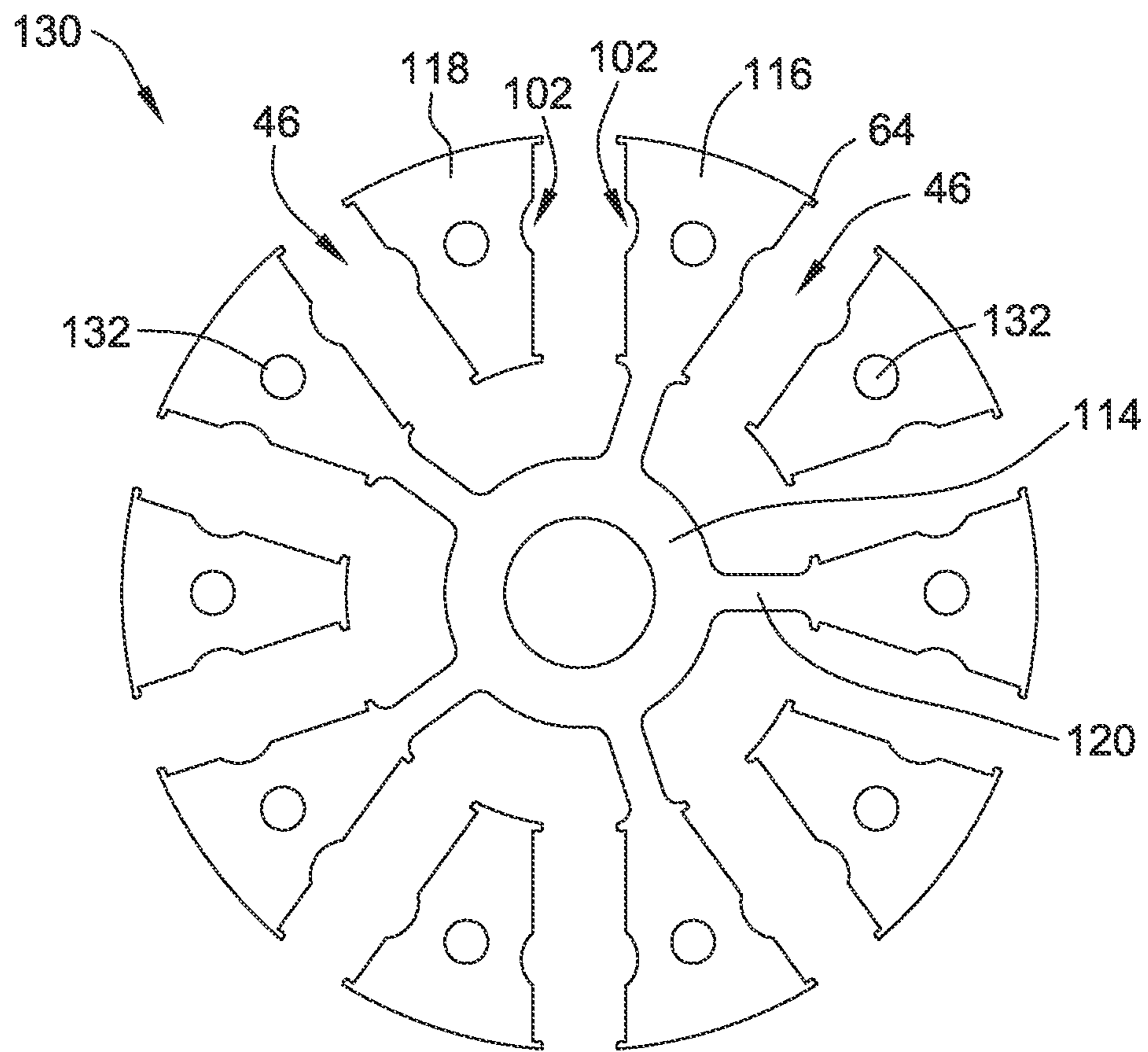

FIG. 13

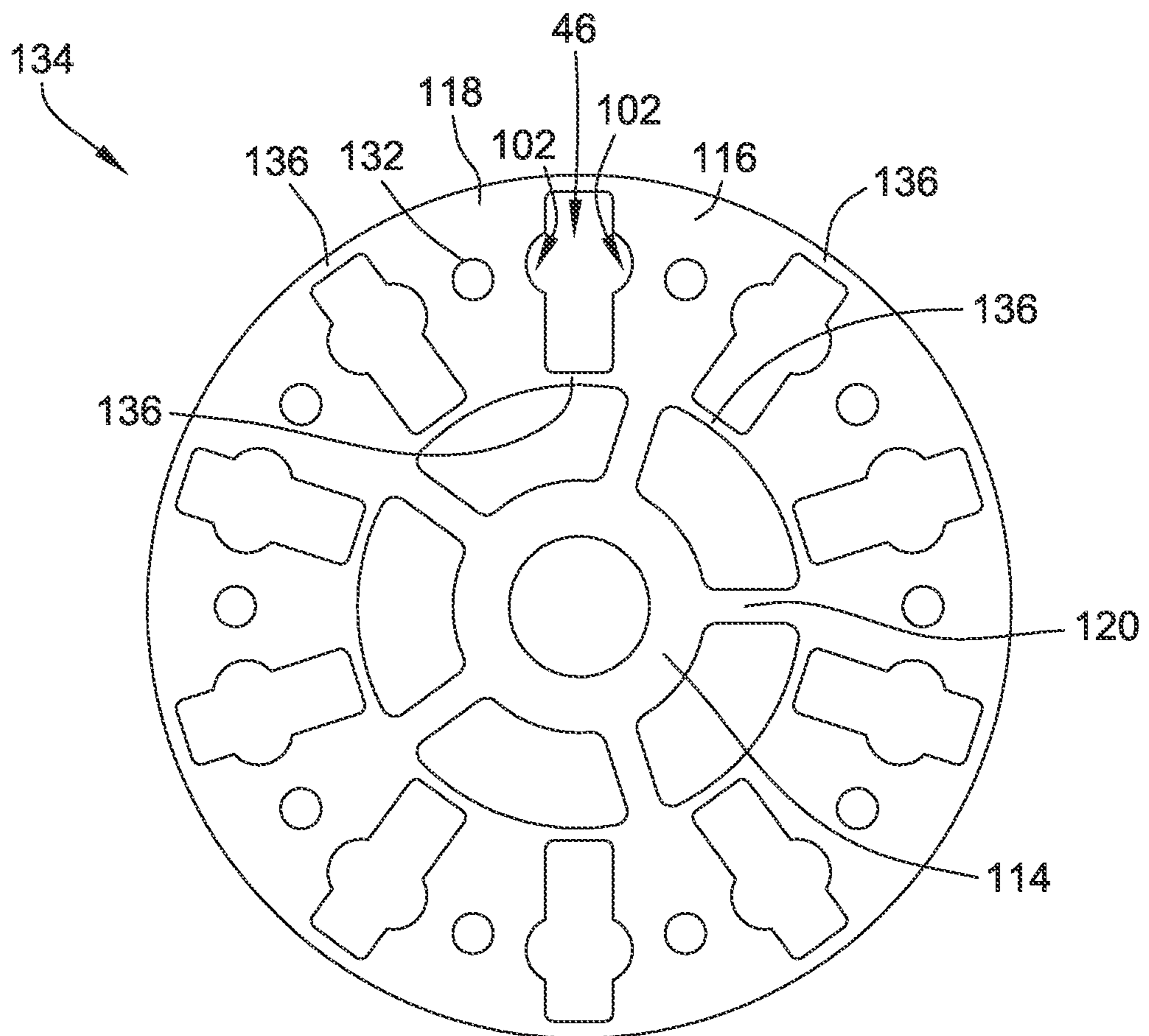

FIG. 14

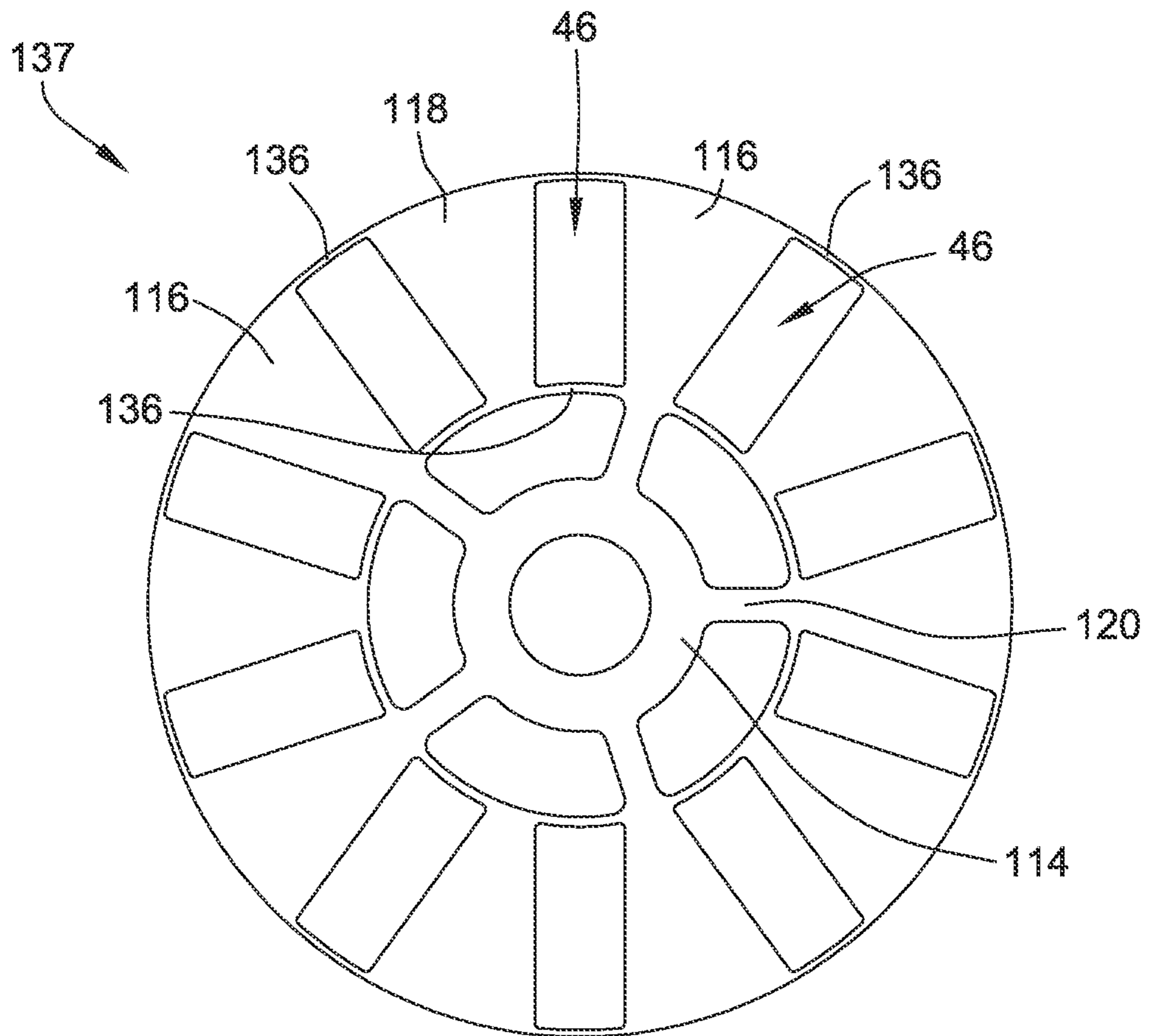

FIG. 15

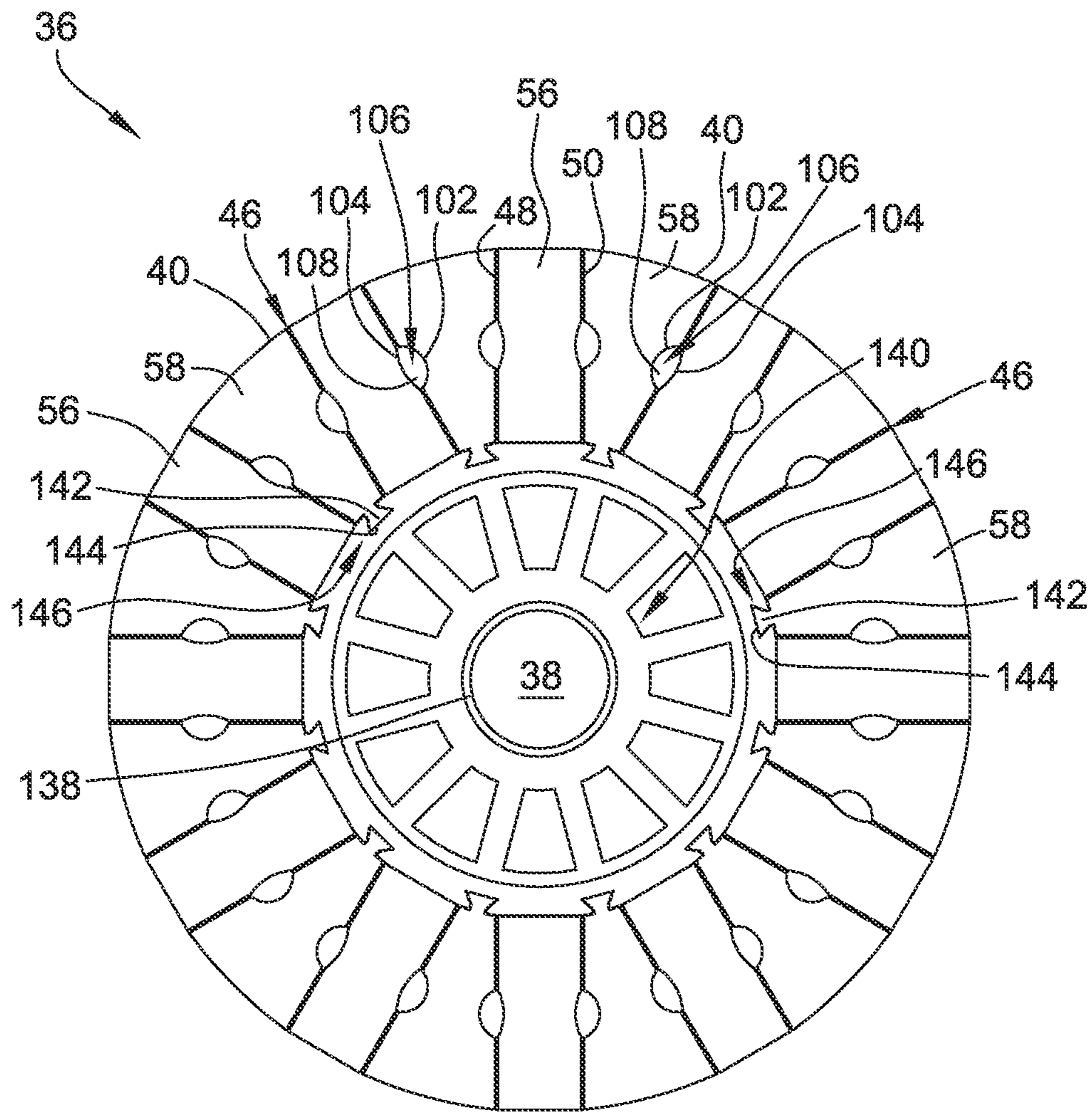

FIG. 16

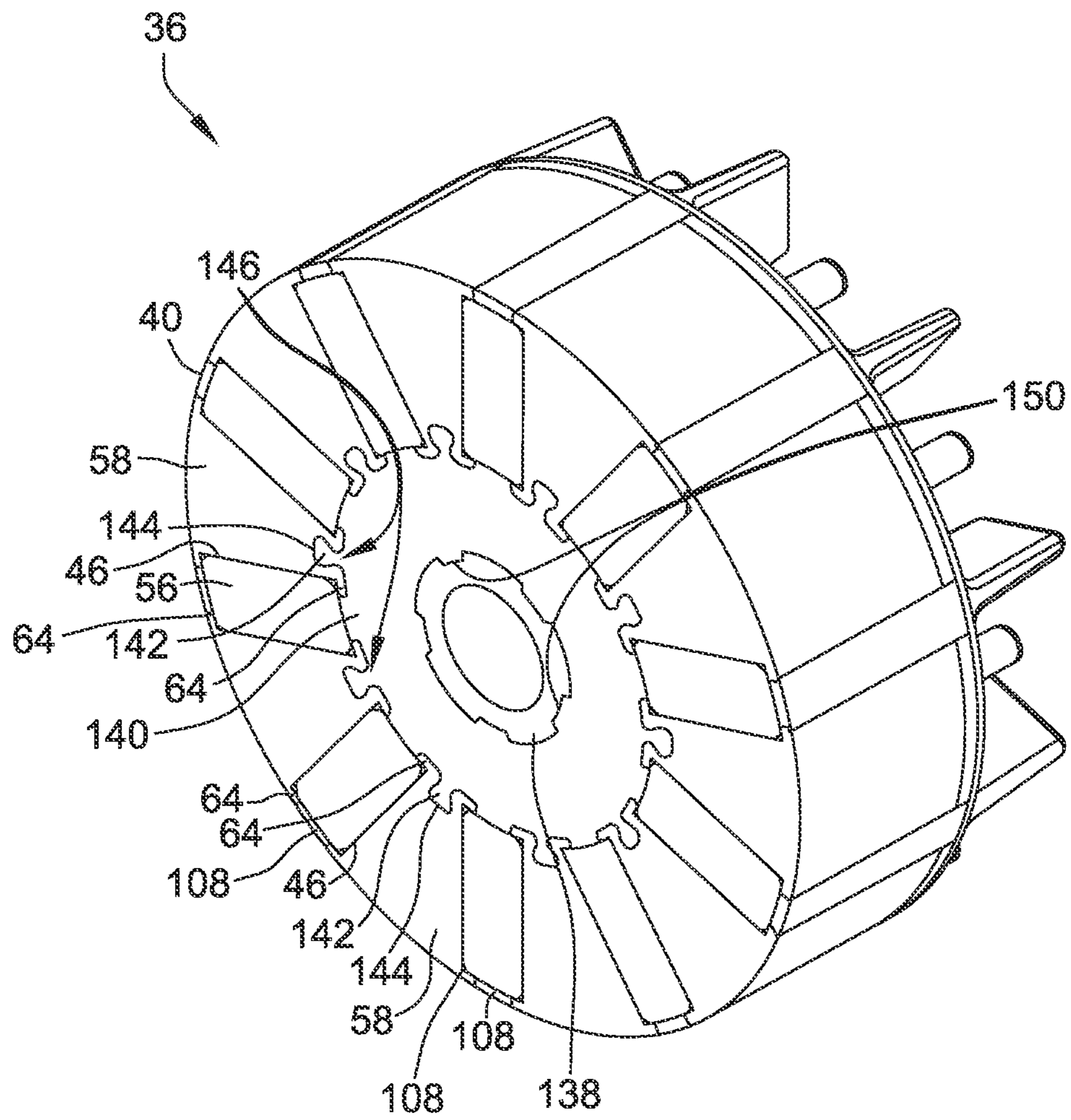

FIG. 17

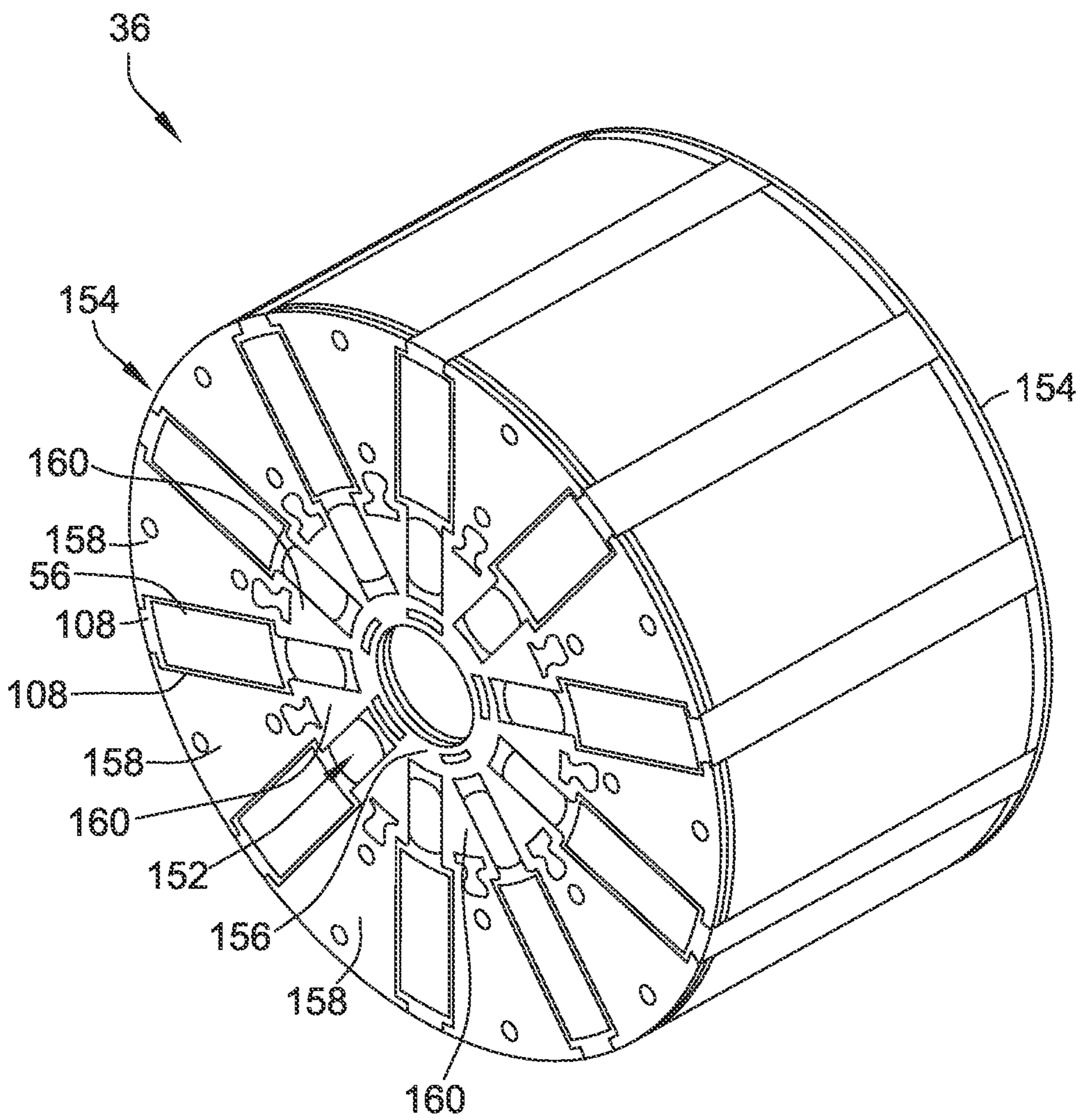

FIG. 18

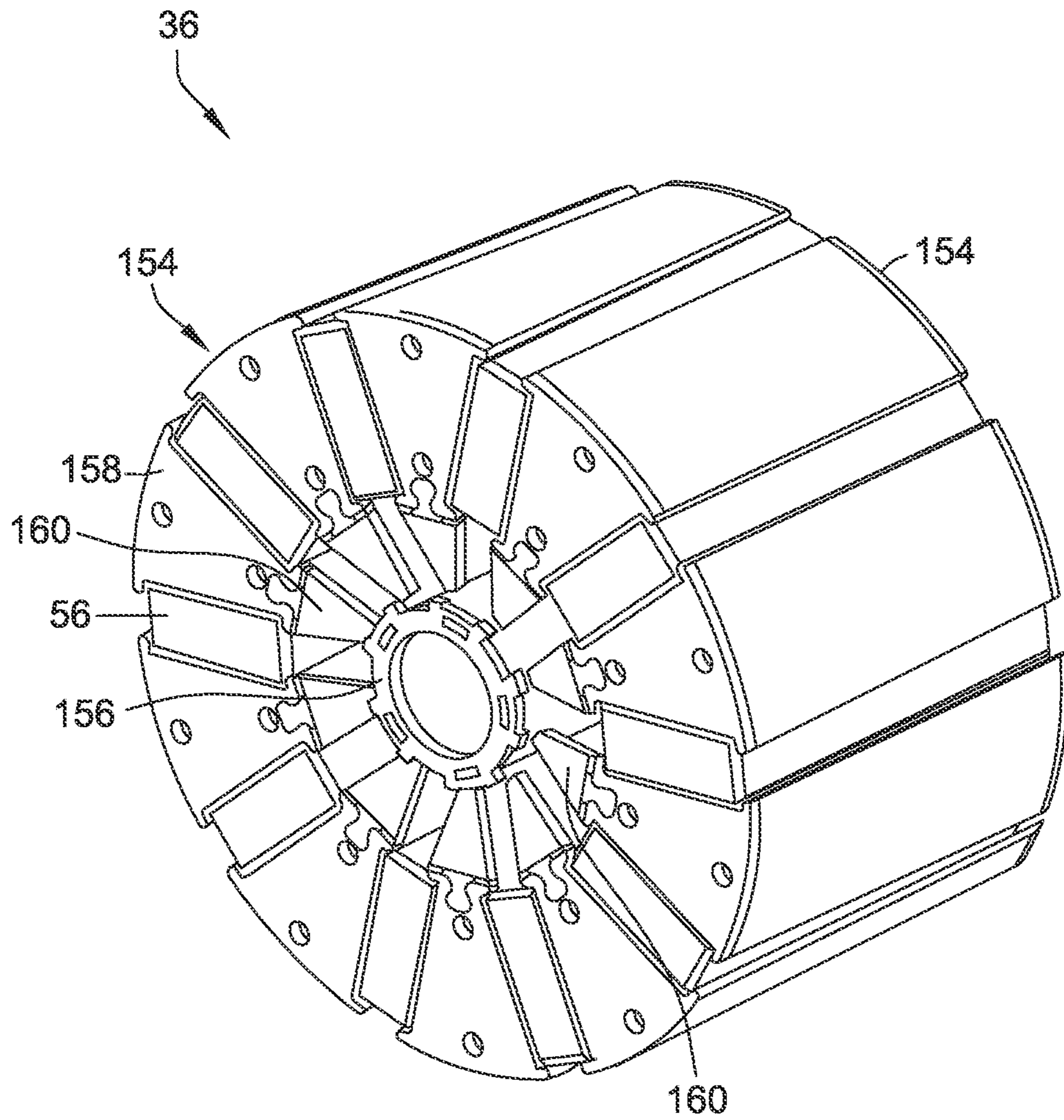

FIG. 20

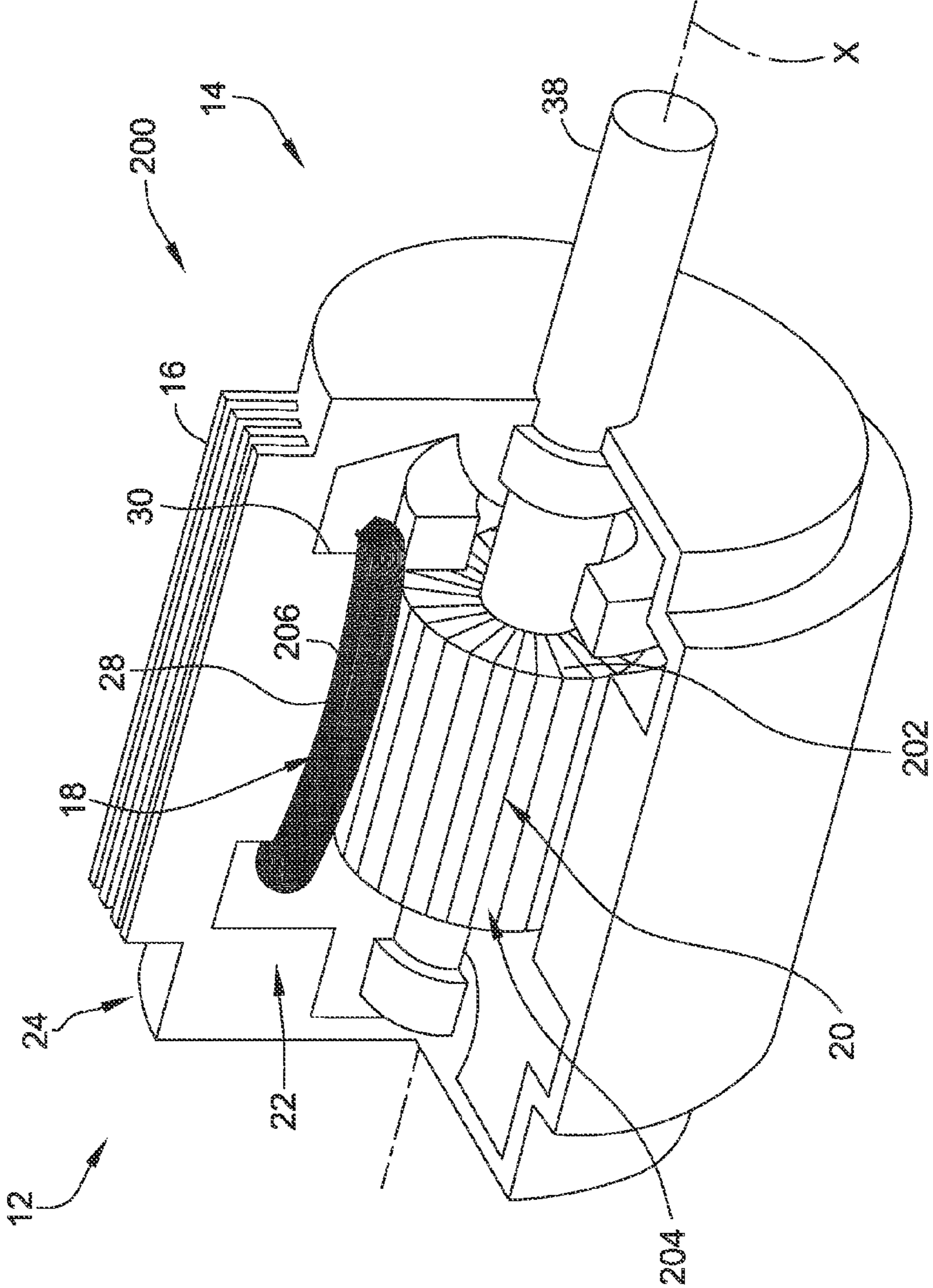
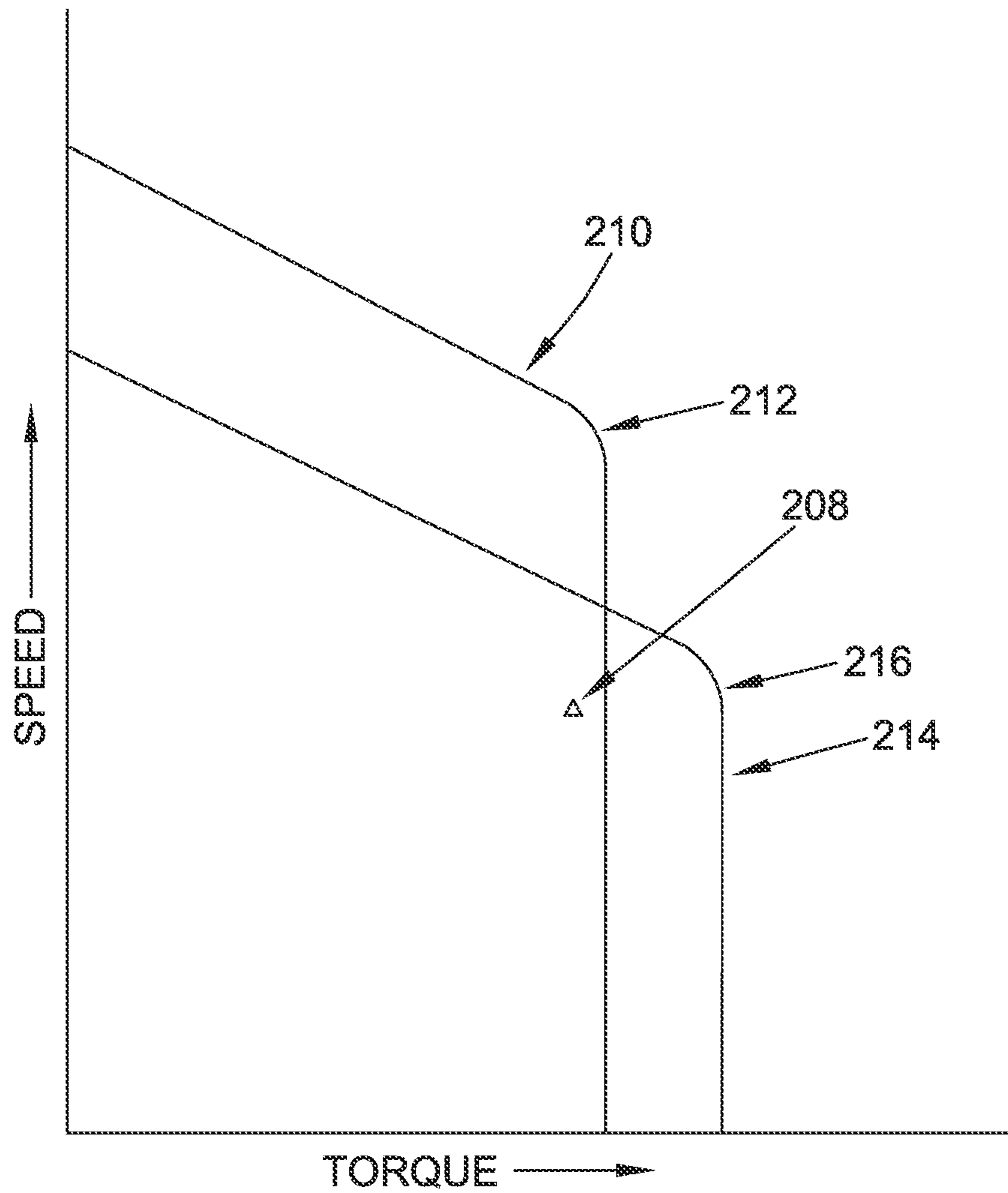
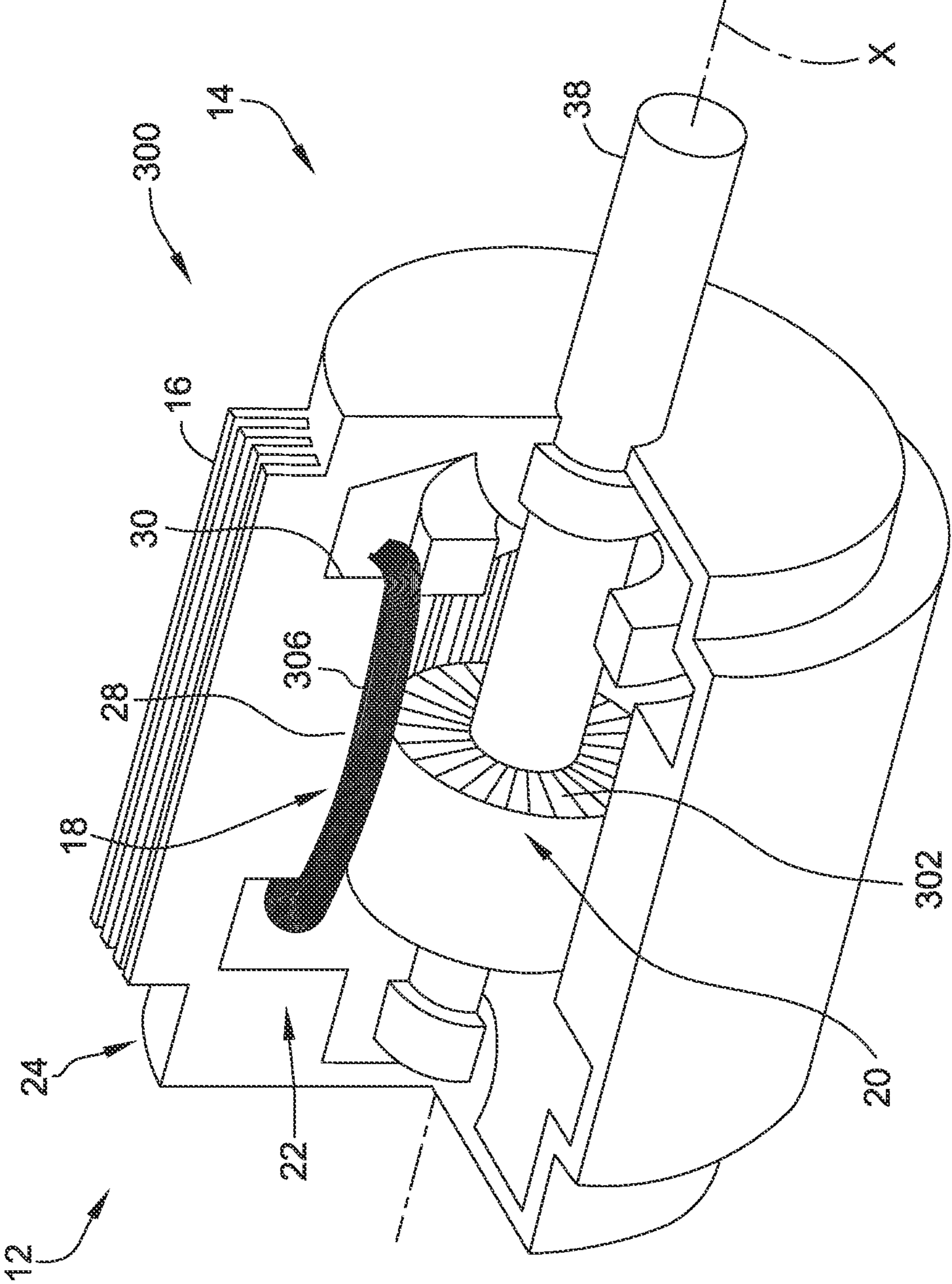

FIG. 21



WINDING OPTIMIZATION TO INCREASES EFF.

FIG. 22



RADIALLY EMBEDDED PERMANENT MAGNET ROTOR AND METHODS THEREOF

BACKGROUND

The field of the disclosure relates generally to electric motors, and more particularly, to radially embedded permanent magnet rotors and alternative materials for use in electric motors.

Various types of electric machines include permanent magnets. For example, a brushless direct current (BLDC) motor may include a plurality of permanent magnets coupled to an exterior surface of a rotor core. Typically, the permanent magnets are coupled to the exterior surface of the rotor core using an adhesive and/or an outer retaining covering. This coupling between the permanent magnets and the rotor core must resist forces exerted on the permanent magnets during high speed rotation tending to separate the permanent magnets from the motor.

Permanent magnets may also be positioned within a rotor core, commonly referred to as an interior permanent magnet rotor. Slots are formed within the rotor, and magnets are inserted into the slots. The magnet slots must be larger than the magnets to allow the magnets to be inserted. However, the magnets must be secured within the slots to prevent movement of the magnets during operation of the machine. The performance of the machine depends on maintaining the magnets in a known position within the rotor. An adhesive may be used to secure the magnets in a fixed position relative to the rotor. However, adhesives have a limited life due to factors such as temperature, temperature cycling, and environmental conditions.

Many known electric machines produce work by generating torque, which is the product of flux, stator current and other constants. In electric motors, flux is typically produced by permanent magnets positioned on a rotor within the motor. Some known rare earth permanent magnets, such as neodymium iron boron magnets, generate greater amounts of flux than typical ferrite permanent magnets. However, the cost of rare earth magnets has drastically risen in recent years, prompting the need for low-cost permanent magnet systems that generate similar amounts of flux and provide efficiencies similar to systems using rare earth magnets.

BRIEF DESCRIPTION

In one embodiment, a permanent magnet rotor is provided. The permanent magnet rotor includes at least one permanent magnet and a substantially cylindrical rotor core including an outer edge and an inner edge defining a central opening. The rotor core includes a radius R , at least one pole, and at least one radial aperture extending radially through the rotor core from the outer edge to a predetermined depth less than the radius. The at least one radial aperture is configured to receive the at least one permanent magnet. The rotor further includes at least one protrusion extending into the at least one radial aperture, the at least one protrusion positioned substantially along a bottom of the at least one radial aperture and configured to facilitate retention of the at least one permanent magnet within the at least one radial aperture.

In another embodiment, an electric machine is provided. The electric machine includes a machine housing, a stator disposed at least partially within the machine housing, and a rotor disposed at least partially within the machine housing, the rotor configured to rotate with respect to the stator. The rotor includes at least one permanent magnet and a substantially cylindrical rotor core including an outer edge and an

inner edge defining a central opening. The rotor core further includes a radius R , at least one pole, and at least one radial aperture extending radially through the rotor core from the outer edge to a predetermined depth less than the radius. The at least one radial aperture is configured to receive the at least one permanent magnet. The rotor further includes at least one protrusion extending into the at least one radial aperture, the at least one protrusion positioned substantially along a bottom of the at least one radial aperture and configured to facilitate retention of the at least one permanent magnet within the at least one radial aperture.

In yet another embodiment, a method of manufacturing a permanent magnet rotor is provided. The method includes providing a rotor core including at least one pole, an outer edge, and an inner edge defining a central opening, the rotor core having a radius R . The method further includes forming at least one radial aperture radially through the rotor core from the outer edge to a predetermined depth less than the radius. The method further includes forming at least one protrusion extending into the at least one radial aperture, the at least one protrusion positioned substantially along a bottom of the at least one radial aperture and configured to facilitate retention of the at least one permanent magnet within the at least one radial aperture, and inserting a permanent magnet into the at least one radial aperture.

BRIEF DESCRIPTION OF THE DRAWINGS

FIG. 1 is a perspective cut-away view of an exemplary electric machine;

FIG. 2 is a front view of an exemplary rotor core that may be included within the electric machine shown in FIG. 1;

FIG. 3 is a front view of another exemplary rotor core that may be included within the electric machine shown in FIG. 1;

FIG. 4 is a front view of another exemplary rotor core that may be included within the electric machine shown in FIG. 1;

FIG. 5 is a front view of the exemplary rotor core shown in FIG. 3 positioned within a stator core;

FIG. 6 is an exploded view of another exemplary rotor core that may be included within the electric machine shown in FIG. 1;

FIG. 7 is a front view of another exemplary rotor core that may be included within the electric machine shown in FIG. 1;

FIG. 8 is an expanded view of the rotor core shown in FIG. 7 with a retention material therein;

FIG. 9 is an expanded view of the rotor core shown in FIG. 7 with another retention material therein;

FIG. 10 is a perspective view of another exemplary rotor core that may be included within the electric machine shown in FIG. 1;

FIG. 11 is a perspective view of the rotor core of FIG. 10 with a rotated end lamination and permanent magnets;

FIG. 12 is a front view of an exemplary lamination that may be included with the rotor core shown in FIG. 10;

FIG. 13 is a front view of another exemplary lamination that may be included with the rotor core shown in FIG. 10;

FIG. 14 is a front view of another exemplary lamination that may be included with the rotor core shown in FIG. 10;

FIG. 15 is a front view of another exemplary rotor core that may be included within the electric machine shown in FIG. 1;

FIG. 16 is a perspective sectional view of another exemplary rotor core that may be included within the electric machine shown in FIG. 1;

FIG. 17 is a perspective view of another exemplary rotor core that may be included within the electric machine shown in FIG. 1;

3

FIG. 18 is a perspective view of the rotor core shown in FIG. 17 with webs mechanically disconnected;

FIG. 19 is a perspective view of another exemplary rotor core that may be included within the electric machine shown in FIG. 1;

FIG. 20 is a perspective cut-away view of another exemplary electric machine;

FIG. 21 is a chart plotting motor speed and torque values; and

FIG. 22 is a perspective cut-away view of another exemplary electric machine.

DETAILED DESCRIPTION

Due to increased costs of rare earth magnets and copper used for windings, lower cost alternative materials are desirable in the design and manufacture of electric motors. This disclosure provides designs and methods using material alternatives to rare earth magnets and copper windings while reducing or recapturing the efficiency losses associated with those alternative materials and reducing or eliminating an increase of the length of the motor.

FIG. 1 is a perspective cut-away view of an exemplary electric motor 10. Although referred to herein as electric motor 10, electric motor 10 can be operated as either a generator or a motor. Electric motor 10 includes a first end 12, a second end 14, and a motor assembly housing 16. Electric motor 10 also includes a stationary assembly 18 and a rotatable assembly 20. Motor assembly housing 16 defines an interior 22 and an exterior 24 of motor 10 and is configured to at least partially enclose and protect stationary assembly 18 and rotatable assembly 20. Stationary assembly includes a stator core 28, which includes a plurality of teeth 30 and a plurality of windings 32 wound around stator teeth 30. In the exemplary embodiment, stator core 28 is a twelve tooth stator structure. Alternatively, stator core 28 may include any number of teeth that enables motor 10 to function as described herein, for example, stator core 28 may have nine teeth. Furthermore, in an exemplary embodiment, stationary assembly 18 is a three-phase salient pole stator assembly and stator core 28 is formed from a stack of laminations made of highly magnetically permeable material. Alternatively, stationary assembly 18 is a single phase salient pole stator assembly. Stationary assembly 18 may be a round, segmented, or roll-up type stator construction and windings 32 are wound on stator core 28 in any suitable manner that enables motor 10 to function as described herein. For example, windings 32 may be concentrated type or overlapped type windings.

Rotatable assembly 20 includes a permanent magnet rotor core 36 and a shaft 38. In the exemplary embodiment, rotor core 36 is formed from a stack of laminations made of magnetically permeable material. Alternatively, rotor core 36 is a solid core. Rotor core 36 is substantially received in a central bore of stator core 28 for rotation along an axis of rotation X. FIG. 1 illustrates rotor core 36 and stator core 28 as solid for simplicity. While FIG. 1 is an illustration of a three phase electric motor, the methods and apparatus described herein may be included within motors having any number of phases, including single phase and multiple phase electric motors.

In the exemplary embodiment, electric motor 10 is coupled to a fan or centrifugal blower (not shown) for moving air through an air handling system, for blowing air over cooling coils, and/or for driving a compressor within an air conditioning/refrigeration system. More specifically, motor 10 may be used in air moving applications used in the heating, ventilation, and air conditioning (HVAC) industry, for example, in

4

residential applications using 1/5 horsepower (hp) to 1 hp motors. Alternatively, motor 10 may be used in fluid pumping applications. Motor 10 may also be used in commercial and industrial applications and/or hermetic compressor motors used in air conditioning applications, where motor 10 may have a rating of greater than 1 hp. Although described herein in the context of an air handling system, electric motor 10 may engage any suitable work component and be configured to drive such a work component.

FIG. 2 is a front view of an exemplary embodiment of rotor core 36 that may be included within electric motor 10 (shown in FIG. 1). In the exemplary embodiment, rotatable assembly 20, also referred to as a radially embedded permanent magnet rotor, includes a rotor core 36 and a shaft 38. Examples of motors that may include the radially embedded permanent magnet rotors include, but are not limited to, electronically commutated motors (ECM's). ECM's may include, but are not limited to, brushless direct current (BLDC) motors, brushless alternating current (BLAC) motors, and variable reluctance motors. Furthermore, rotatable assembly 20 is driven by an electronic control (not shown), for example, a sinusoidal or trapezoidal electronic control.

Rotor core 36 is substantially cylindrical and includes an outer edge 40 and a shaft central opening or inner edge 42 having a diameter corresponding to the diameter of shaft 38. Rotor core 36 and shaft 38 are concentric and are configured to rotate about axis of rotation X (shown in FIG. 1). In the exemplary embodiment, rotor core 36 includes a plurality of laminations 44 that are either interlocked or loose. For example, laminations 44 are fabricated from multiple punched layers of stamped metal such as steel. In an alternative embodiment, rotor core 36 is a solid core. For example, rotor core 36 may be fabricated using a sintering process from a soft magnetic composite (SMC) material, a soft magnetic alloy (SMA) material, and/or a powdered ferrite material.

In the exemplary embodiment, rotor core 36 includes a plurality of radial apertures 46. For example, a first wall 48, a second wall 50 and a third wall 52 define a first radial aperture 54 of the plurality of radial apertures 46. Each radial aperture 46 includes a depth d and thickness t and extends axially through rotor core 36 from first end 12 (shown in FIG. 1) to second end 14 (also shown in FIG. 1). Each radial aperture 46 is configured to receive one or more permanent magnets 56 such that each magnet 56 is radially embedded in rotor core 36 and extends at least partially from rotor first end 12 to rotor second end 14. In the exemplary embodiment, permanent magnets 56 are hard ferrite magnets magnetized in a direction tangent to axis of rotation X. However, magnet 56 may be fabricated from any suitable material that enables motor 10 to function as described herein, for example, bonded neodymium, sintered neodymium, and/or samarium cobalt.

In the exemplary embodiment, rotor core 36 includes a plurality of rotor poles 58, each having an outer wall 60 along rotor outer edge 40 and an inner wall 62 (shown in FIG. 3). In the exemplary embodiment, the number of radial apertures 46 is equal to the number of rotor poles 58, and one magnet 56 is positioned within each radial aperture 46 between a pair of rotor poles 58. Although illustrated as including ten rotor poles 58, rotor core 36 may have any number of poles that allows motor 10 to function as described herein, for example, six, eight or twelve poles.

In the exemplary embodiment, the design of radially embedded permanent magnet rotor core 36 utilizes lower-cost magnets, yet achieves the power densities and high efficiency of machines using higher-cost magnets, such as neodymium magnets. In the exemplary embodiment, increased efficiency and power density of motor 10 is

5

obtained by increasing the flux produced by rotor core 36. Increased flux generation is facilitated by magnets 56 positioned in radial apertures 46 at depth d , between a minimum magnet depth and a maximum magnet depth. The minimum magnet depth is defined by the equation:

$$D_{min} = \frac{(\pi * R)}{n},$$

wherein D_{min} represents the minimum depth variable, R represents the rotor radius, and n represents the number of rotor poles. The maximum magnet depth is defined by the equation:

$$D_{max} = R - \frac{0.5t}{\tan\left(\frac{180}{n}\right)},$$

wherein D_{max} represents the maximum depth variable, R represents the rotor radius, t represents the magnet thickness in the direction of magnetization, and n represents the number of rotor poles. In the exemplary embodiment, rotor core 36 facilitates increased flux production resulting in optimum efficiency and power density when magnets 56 extend into radial aperture at a depth between D_{min} and D_{max} .

FIG. 3 is a front view of another exemplary embodiment of rotor core 36 that may be included within electric motor 10. In the exemplary embodiment, rotor core 36 includes radial apertures 46 configured to receive one or more permanent magnets 56. In the exemplary embodiment, radial apertures 46 are generally rectangular. Alternatively, radial apertures 46 may have any suitable shape corresponding to the shape of the permanent magnets that enables electric motor to function as described herein. For example, radial apertures 46 may be tapered, as described in more detail below.

In the exemplary embodiment, radial aperture 46 includes one or more permanent magnet retention member or protrusion 64. For example, a first pair of protrusions 66 is located proximate pole outer wall 60 along rotor outer edge 40 and extends into radial aperture 46 from first and second walls 48 and 50. Each protrusion 64 of the first pair of protrusions 66 is configured to facilitate retention of magnet 56 within radial aperture 46 by substantially preventing movement of magnet 56 in a radial direction towards outer edge 40. Further, a second pair of protrusions 68 is located along pole inner wall 62 and extends into radial aperture 46 from first and second walls 48 and 50. Each protrusion 64 of the second pair of protrusions 68 is configured to facilitate retention of magnet 56 within radial aperture 46 by substantially preventing movement of magnet 56 in a radial direction towards shaft 38. Alternatively, rotor core 36 may have any number and location of protrusions 64 that enable rotor core 36 to function as described herein.

FIG. 4 is a front view of another exemplary embodiment of rotor core 36 that may be included within electric motor 10. Rotor core 36 includes radial apertures 46 configured to receive one or more permanent magnet 56. In the exemplary embodiment, radial apertures 46 and magnet 56 are generally tapered. First and second walls 48 and 50 of radial aperture 46 converge as they extend from rotor inner wall 62 to rotor outer wall 60 and are configured to engage the tapered walls of magnet 56 to facilitate retention of magnet 56 within radial aperture 46 by substantially preventing movement of magnet 56 in a radial direction towards rotor outer edge 40. Further-

6

more, each tapered radial aperture 46 may include a pair of protrusions 68 located along pole inner wall 62 to facilitate retention of magnet 56 within radial aperture 46 by substantially preventing movement of magnet 56 in a radial direction towards shaft 38.

FIG. 5 is a front view of rotor core 36 shown in FIG. 3 positioned within stator core 28. In the exemplary embodiment, rotor core 36 is positioned relative to stator core 28, and rotor outer edge 40 and an inner edge 74 of stator core 28 define a small air gap 72. Air gap 72 allows for relatively free rotation of rotor core 36 within stator core 28. Radially embedded magnets 56 of rotor core 36 are configured to facilitate increased flux to air gap 72, resulting in increased motor torque generation. The radial orientation of radially embedded magnets 56 results in the magnet flux only crossing the magnet once, as opposed to the flux produced by surface-mounted magnets, which must cross the magnets twice. Crossing magnet 56 only once significantly reduces the path of the flux through material of low permeability (i.e. air and magnet 56), resulting in increased flux delivery and torque. Increased flux delivery and torque also result from radial magnets 56 of the same polarity positioned on opposite edges 48 and 50 of each rotor pole 58, which focuses flux toward rotor outer edge 40. However, any magnetic support structure above or below magnet 56 in a radial direction provides a path for flux to flow without crossing air gap 72, resulting in torque losses. In the exemplary embodiment of FIG. 5, only a small or limited amount of magnetic material (i.e. protrusions 64) is positioned above or below magnet 56. Alternatively, rotor core 36 does not include any magnetic material immediately above or below magnet 56 such that no magnetic material is positioned between permanent magnet 56 and rotor outer edge 40 and between permanent magnet 56 and inner sleeve 138 (see FIG. 15).

In the exemplary embodiment, rotor poles 58 are spaced from each other a distance f to reduce flux loss through magnetic support structure (e.g. rotor poles 58). In the exemplary embodiment, distance f is greater than or equal to five times the length of air gap 72 (the gap between rotor outer edge 40 and stator inner edge 74), facilitating high flux generation. Alternatively, distance f is greater than or equal to three times the length of air gap 72. Alternatively still, distance f is greater than or equal to ten times the length of air gap 72. In the exemplary embodiment, distance f is maintained between protrusions 64. Alternatively, distance f is maintained between radial aperture walls 48 and 50 if no protrusions 64 are present, or between protrusion 64 and wall 48 or 50 if protrusion 64 is present on only one of walls 48 and 50.

FIG. 6 is an exploded view of another exemplary embodiment of rotor core 36 that may be included within electric motor 10. In the exemplary embodiment, rotor core 36 includes a first half-core 76, a second half-core 78, a center lamination 80, and first and second end laminations 82 and 84. Half-cores 76 and 78 each include a plurality of independent rotor poles 58 positioned radially about a sleeve 86. A plurality of radial apertures 46 are defined between rotor poles 58 and are configured to receive one or more permanent magnets 56. Each rotor pole 58 is held in spaced relation to sleeve 86 by at least one of center lamination 80 and end laminations 82 and 84. In the exemplary embodiment, laminations 80, 82 and 84, also referred to as shorting laminations, are structurally similar, and each includes a plurality of connected rotor poles 88 positioned radially about a central hub 90. Rotor poles 88 each include an outer edge 92 and an inner edge 94. Adjacent pairs 96 of rotor poles 88 are connected at inner edges 94 by a bridge 98, which is connected to central hub 90.

In the exemplary embodiment, center lamination **80** is positioned between half-cores **76** and **78**, and end laminations **82** and **84** are positioned on opposite ends of rotor core **36**. In the exemplary embodiment, half-cores **76** and **78** are solid cores. Alternatively, half-cores **76** and **78** are formed as a whole core and/or are fabricated from a plurality of lamination layers. Although rotor core **36** is described with a single center lamination **80** and two end laminations **82** and **84**, rotor core **36** may have any number of center and end laminations that enables motor **10** to function as described herein. Connected rotor poles **88** support rotor poles **58** at a distance from sleeve **86** to prevent flux losses in half-cores **76** and **78**, since little or no magnetic material is located above or below magnets **56** positioned therein. A portion of flux generated by rotor core **36** is lost, however, due at least in part to connected rotor poles **88** of laminations **80**, **82** and **84**. In order to minimize flux losses, in the exemplary embodiment, the sum of the thicknesses of laminations having connected rotor poles **88** is less than or equal to 12% of the total length of rotor core **36**. Alternatively, the sum of the thicknesses of laminations having connected rotor poles **88** is less than or equal to 2% of the total length of rotor core **36**. Alternatively still, the sum of the thicknesses of laminations having connected rotor poles **88** is less than or equal to 1% of the total length of rotor core **36**.

FIGS. 7-9 illustrate another exemplary embodiment of rotor core **36** that may be included within electric motor **10**. FIG. 7 is a front view of rotor core **36** that includes a hub **100** defining an inner edge **42** sized to receive shaft **38**, and a plurality of rotor poles **58** positioned radially about hub **100** defining a plurality of radial apertures **46**, which are configured to receive one or more permanent magnet **56**. In the exemplary embodiment, hub **100** is fabricated from aluminum and/or zinc and pressed directly onto shaft **38**. Alternatively, hub **100** is fabricated from any non-magnetic material that enables rotor core **36** to function as described herein. In the exemplary embodiment, a first indentation **102** is formed in each of first wall **48** and second wall **50**, and two second indentations **104** are formed in magnet **56**. Alternatively, only one of indentation **102** and indentation **104** is formed, or any number and location of indentations **102** and **104** may be formed in walls **48** and **50** and magnet **56** that enables rotor **36** to function as described herein. Moreover, indentations **102** and **104** may have any suitable shape and size that enables rotor core **36** to function as described herein. For example, second indentation **104** may be smaller in size and/or have a smaller radius than first indentation **102**.

In the exemplary embodiment, each first indentation **102** is substantially aligned with a corresponding second indentation **104** to define a space **106**. Alternatively, first indentations **102** are formed without forming second indentations **104**, and vice versa. Space **106** is configured to receive a retention material **108**, which is configured to at least partially fill space **106** and cause interference between the surfaces of indentations **102** and **104** to substantially resist or prevent movement of magnet **56** within radial aperture **46**. For example, retention material **108** frictionally engages the surfaces of indentations **102** and **104** and prevents magnet **56** from moving radially relative to radial aperture **46**, which can result in unwanted noise or magnet dislocation. Further, retention material **108** is configured to prevent general side-to-side motion of magnet **56**, which can occur due to tolerance stack-up and can result in unwanted noise from magnets **56** rattling against the faces of rotor poles **58**. Retention material **108** may be formed from one segment or multiple segments and extend through the full length or through only a portion of rotor core **36**.

In the exemplary embodiment, retention material **108** may be any material or member that at least partially fills space **106** and substantially prevents movement of magnet **56** within radial aperture **46**. For example, as illustrated in FIG. 8, the retention material is a resilient hollow outer member **110** positioned within space **106**. However, retention material **108** is not limited to a single material. For example, a hardened material member (not shown) may be inserted through hollow outer member **110** to facilitate additional interference between indentations **102** and **104**. An alternative embodiment is shown in FIG. 9, which illustrates an expanding foam **112** as the retention material. Expanding foam **112** is deposited within space **106**, and expands to engage the surfaces of indentations **102** and **104** and facilitate retention of magnet **56** within radial aperture **46**. Alternatively, retention material **108** may be, for example, a pre-fabricated plastic or metal member (not shown), a formed in place member (not shown) such as with injection molded polymer, plastic or metal or an expanding material, a resilient member (not shown), an elastic member (not shown), a wedging member (not shown), a biasing mechanism such as a spring (not shown), or any combination thereof. Furthermore, retention material **108** may be used in place of, or in addition to, adhesives to retain magnet **56** within radial aperture **46**.

FIG. 10 illustrates a perspective view of another exemplary embodiment of rotor core **36** that may be included within electric motor **10**. In the exemplary embodiment, rotor core **36** is formed from a plurality of laminations **44** that each includes a hub **114**, a plurality of connected rotor poles **116**, and a plurality of independent rotor poles **118**. Rotor poles **116** and **118** are positioned radially about hub **114**. Each connected rotor pole **116** is coupled to hub **114** by a web **120**. In the exemplary embodiment, a sleeve **122** fabricated from a non-magnetic material, for example aluminum, is positioned between hub **114** and shaft **38** to provide mechanical stability and prevent a magnetic path to shaft **38**. Alternatively, sleeve **122** is excluded and/or shaft **38** is at least partially formed from a non-magnetic material to prevent a magnetic path thereto. Radial apertures **46** are defined between adjacent rotor poles **116** and **118** and are configured to receive one or more permanent magnet **56**. Rotor poles **116** and **118** also include magnet retention features **64** configured to retain magnet **56** within radial aperture **46**, as described above. Illustrated in FIG. 11, one or more laminations **124** are rotated to support independent rotor poles **118** in spaced relation to hub **114**. Each rotated lamination **124** includes a plurality of connected rotor poles **126** and independent rotor poles **128**. Rotated lamination **124** is oriented or rotated in a clockwise or counterclockwise direction by one pole such that each connected rotor pole **126** is aligned with and supports one independent rotor pole **118**, and each independent rotor pole **128** is aligned and supported by one connected rotor pole **116**.

In the exemplary embodiment, two rotated laminations **124** are positioned on rotor first end **12**. Additionally, one or more rotated laminations **124** are positioned on rotor second end **14**. However, any number of rotated laminations **124** may be positioned anywhere throughout the stack of laminations **44** that enables rotor core **36** to function as described herein. For example, rotated lamination **124** may be located substantially within the center of the lamination stack of rotor core **36**. In the exemplary embodiment, rotated lamination **124** is fabricated from steel. Alternatively, rotated lamination **124** is formed from any non-magnetic material such as aluminum or molded plastic.

In the exemplary embodiment, each permanent magnet **56** is positioned within one radial aperture **46** by inserting magnet **56** therethrough in an axial direction parallel to axis X.

Alternatively, each permanent magnet **56** is inserted into one radial aperture **46** in a direction radial to hub **114**, for example, when protrusions **64** are not present on outer edge **40**. Each permanent magnet **56** includes a first polarity pole N and a second polarity pole S. In the exemplary embodiment, magnets **56** are arranged within radial aperture **46** such that each pole N faces one connected rotor pole **116** and each pole S faces one independent rotor pole **118**. This arrangement results in little or no flux leakage because each rotor pole **116** and **118** is only in contact with the same magnetic polarity. Alternatively, magnets **56** are arranged such that each pole S faces one connected rotor pole **116** and each pole N faces one independent rotor pole **118**.

FIGS. **12-14** illustrate alternate exemplary embodiments of laminations **44** positioned on rotor ends **12** and **14** or anywhere throughout laminated rotor core **36**. For example, FIG. **12** illustrates a front view of a lamination **130** that is similar to lamination **124** illustrated in FIG. **10**, except lamination **130** includes apertures **132** and indentations **102** formed in connected rotor poles **116** and independent rotor poles **118**. Indentations **102** are configured to align with indentations **104** formed in magnets **56** to define a space **106**, which is configured to receive a retention material **108**, as described above. Apertures **132** are configured to receive fasteners (not shown) to facilitate aligning and coupling multiple laminations **130**. FIG. **13** illustrates a front view of a lamination **134** that is similar to lamination **130**, except connected rotor poles **116** and independent rotor poles **118** are connected by bridges **136**. FIG. **14** illustrates a front view of a lamination **137** that is similar to lamination **134**, except lamination **137** excludes indentations **102** and apertures **132**. Moreover, when used as end laminations, the laminations described above may include radial apertures **46** sized smaller than magnets **56** to prevent magnet **56** from sliding out a rotor end during axial insertion of magnet **56**.

FIG. **15** is a front view of another exemplary embodiment of rotor core **36** that may be included within electric motor **10**. In the exemplary embodiment, rotor core **36** includes a sleeve **138** configured to receive shaft **38**, a central hub **140**, and a plurality of rotor poles **58** positioned radially about central hub **140**. Rotor poles **58** are solid or laminated and define a plurality of radial apertures **46** therebetween, which are configured to receive one or more permanent magnet **56**. Rotor poles **58** include indentations **102** that are substantially aligned with indentations **104** in permanent magnets **56** to form a space **106**. Each rotor pole **58** includes a protrusion **142** that extends into a recess **144** formed in central hub **140**. Each protrusion **142** and corresponding recess **144** forms an interlock **146**. In the exemplary embodiment, interlock **146** is a dovetail joint configured to facilitate increased torque transmission between rotor poles **58** and central hub **140**. Alternatively, interlock **146** may have any geometry that enables rotor core **36** to function as described herein.

In the exemplary embodiment, radial aperture **46** includes first and second walls **48** and **50** defined by rotor poles **58**. A retention material **108** is positioned within radial aperture **46** and space **106** between magnet **56** and first and second walls **48** and **50**. An annular end plate (not shown) is positioned on rotor core ends. In the exemplary embodiment, retention material **108** is an injection molded polymer. However, retention material **108** may be any suitable material that enables rotor core **36** to function as described herein. Additionally, retention material **108** may be positioned between magnet **56** and an outer edge **40** of rotor core **36**. In the exemplary embodiment, sleeve **138** and rotor poles **58** are fabricated from steel. However, sleeve **138** and rotor poles **58** may be formed from any suitable material that enables rotor core **36**

to function as described herein. Alternatively, sleeve **138** may be excluded and central hub **140** is directly coupled to shaft **38**. In the exemplary embodiment, central hub **140** is fabricated from an injection molded polymer. However, central hub **140** may be formed from any suitable non-magnetic material that enables rotor core **36** to function as described herein. For example, central hub **140** may be a machined, extruded or die cast non-magnetic material such as aluminum or zinc. Alternatively, central hub **140** is fabricated from an isolation damping material configured to reduce transmission of at least one of motor torque pulsations, motor torque ripple, and motor torque cogging.

An exemplary method of manufacturing rotor core **36** is described herein. Sleeve **138**, rotor poles **58** and permanent magnets **56** are located substantially symmetrically in a mold (not shown). Alternatively, sleeve **138** may be excluded. Rotor poles **58** and sleeve **138** are a solid structure or laminated structure held together with interlocks, rivets, bolts, and/or other fasteners. In the exemplary embodiment, pre-formed magnets **56** are inserted into radial apertures **46** defined between rotor poles **58**. Alternatively, a polymer bonded magnet material is injected into the radial apertures **46** to form permanent magnets **56**. In the exemplary embodiment, a non-magnetic polymer is injection molded into the region between rotor poles **58** and magnets **56**, in the region between magnets **56** and rotor outer edge **40**, and in spaces **106** defined by indentations **102** and **104**. The polymer is further injection molded in the region between sleeve **138** and rotor poles **58** and magnets **56** to form central hub **140**. In this way, the injection molding process magnetically isolates rotor poles **58** and magnets **56** on the outer diameter of rotor **36** and orients rotor poles **58** and magnets **56** at a predetermined diameter equal to a desired rotor outer diameter. Magnets **56** may be magnetized before insertion into the mold or may be magnetized after the molding process. Alternatively, central hub **140** is a pre-formed non-magnetic material, for example zinc or aluminum, that is inserted into the mold after magnets **56** are installed and magnetized. An annular end plate (not shown) is then positioned on rotor core ends. Alternatively, sleeve **138** and rotor poles **58** are located substantially symmetrically in the mold. A high strength polymer material with a high first processing temperature (e.g. glass-filled Rynite material) is injection molded in the region between sleeve **138** and rotor poles **58** to form central hub **140**. The processing temperature is the temperature at which a material can be processed in a conventional injection molding process and is above the higher of the melting point and the glass transition temperature. Permanent magnets **56** are then inserted into radial apertures **46** defined between rotor poles **58**, and a polymer material with a lower second processing temperature (e.g. glass-filled Crastin) is molded in the remaining space around magnets **56**. This two-step molding process prevents performing the high temperature material injection while magnets **56** are in the mold, which may reduce the effectiveness of magnets **56**.

FIG. **16** is a section view of another exemplary embodiment of rotor core **36** that may be included within electric motor **10**. In the exemplary embodiment, rotor core **36** includes a sleeve **138** configured to receive shaft **38**, a central hub **140**, and a plurality of rotor poles **58** positioned radially about central hub **140**. Sleeve **138** includes indentations **150** to provide an interlock with central hub **140** to facilitate increased torque transmission therebetween. In the exemplary embodiment, hub **140** is solid. Alternatively, hub **140** is fabricated with apertures **152** (see FIG. **17**). Rotor poles **58** are a solid or laminated structure and define a plurality of radial apertures **46**, which are configured to receive one or

more permanent magnets **56**. Rotor poles **58** include protrusions **64**, which are configured to retain magnets **56** within radial apertures **46**, as described above. Each rotor pole **58** includes a recess **144** that receives protrusion **142** extending from central hub **140**. Each protrusion **142** and corresponding recess **144** forms an interlock **146**, which is configured to facilitate increased torque transmission between rotor poles **58** and central hub **140**. In an alternate embodiment, interlock **146** may have any geometry that enables rotor core **36** to function as described herein. Alternatively, rotor poles **58** are coupled to central hub **140** in any manner that enables torque transmission between rotor poles **58** and central hub **140**, for example, by adhesives, mechanical fasteners, etc.

In the exemplary embodiment, radial aperture **46** receives one or more magnet **56** and a retention material **108** is positioned within radial aperture **46** between magnet **56** and rotor outer edge **40**. As illustrated in FIG. **17**, one or more end laminations **154** are positioned on rotor ends **12** and **14**. In the exemplary embodiment, each end lamination **154** includes a hub **156** connected to a plurality of rotor poles **158** by webs **160**. Alternatively, since webs **160** provide a magnetic path through the rotor and between rotor poles **158**, which results in some flux leakage, webs **160** may be mechanically disconnected or sheared from hub **156** (see FIG. **18**) and then molded over when forming hub **156**. Mechanically disconnecting webs **160** provides resiliency between the rotor outer diameter and hub **140**, which reduces torque pulsations, vibration, noise and undesirable cogging torque and/or ripple torque. Alternatively, one or more bridges (not shown) are formed between adjacent rotor poles **158** along rotor outer diameter **40** and/or anywhere along radial apertures **46**. As such, the bridges of end lamination **154** secure rotor core **36** and increase rigidity during punch and interlock, stacking, and/or transport. Once rotor core **36** is formed, the bridges may be mechanically disconnected for plastic molding, potting and/or epoxy filling operations.

An exemplary method of manufacturing rotor core **36** is described herein. Rotor core **36** is fabricated by punching multiple interlocked laminations that each includes a sleeve **138** and a plurality of rotor poles **58**. The laminations are stacked and may or may not be indexed to reduce rotor imbalances. One or more magnets **56** are positioned radially about sleeve **138** between rotor poles **58** by inserting each magnet **56** axially and/or radially into radial aperture **46**. One or more end laminations **154** are positioned on rotor core end **12** and/or **14**, and rotor core **36** is located in a mold (not shown). Optionally, a plurality of rotor poles **158** of end lamination **154** may be mechanically disconnected from a hub **156** by breaking or shearing webs **160**. A non-magnetic polymer is injection molded into the region between rotor poles **58** and magnets **56**, in the region between magnets **56** and rotor outer edge **40**, and in the region between sleeve **138** and rotor poles **58** and magnets **56** to form central hub **140**. The polymer may also be injection molded over mechanically disconnected webs **160**. In this way, the injection molding process magnetically isolates rotor poles **58** and magnets **56** on the outer diameter of rotor **36** and orients rotor poles **58** and magnets **56** at a predetermined diameter equal to a desired rotor outer diameter. Magnets **56** may be magnetized before insertion into the mold, or may be magnetized during or after the molding process. End lamination **154** may be coupled to rotor core **36** before, during or after the molding process.

FIG. **19** is a section view of another exemplary embodiment of rotor core **36** that may be included within electric motor **10**. In the exemplary embodiment, rotor core **36** includes an inner hub **162** configured to receive shaft **38**, an outer hub **164**, and a plurality of rotor poles **58** positioned

radially about outer hub **164**. Rotor poles **58** are solid or laminated and define a plurality of radial apertures **46** therebetween, which are configured to receive one or more permanent magnet **56**. Each rotor pole **58** includes a protrusion **142** that extends into a recess **144** in outer hub **164** to form an interlock **146**. In the exemplary embodiment, interlock **146** is a dovetail joint configured to facilitate increased torque transmission between rotor poles **58** and outer hub **164**.

In the exemplary embodiment, radial aperture **46** receives one or more permanent magnet **56**. A molded material (e.g. injection molded polymer) may be positioned within radial aperture **46** between magnet **56** and rotor outer edge **40** and between magnet **56** and outer hub **164**. Similarly, the material is positioned in a space **166** between outer hub **164** and inner hub **162** to form a central hub (not shown). Inner and outer hubs **162** and **164** each include protrusions **168**, which facilitate increased torque transmission therebetween. In the exemplary embodiment, inner and outer hubs **162** and **164** are fabricated from a non-magnetic material (e.g. aluminum). Alternatively, hubs **162** and **164** are fabricated from any non-magnetic material that enables rotor **36** to function as described herein. Alternatively, inner hub **162** is fabricated from a magnetic material.

An exemplary method of manufacturing rotor core **36** is described herein. Inner hub **162**, outer hub **164**, rotor poles **58** and magnets **56** are located substantially symmetrically in a mold (not shown). Rotor poles **58** and hubs **162** and **164** are a solid structure or a laminated structure held together with interlocks, rivets, bolts, and/or other fasteners. Magnets **56** are inserted into radial apertures **46** or a magnetic material is injected therein to form magnets **56**. A non-magnetic polymer is injection molded into space **166** between outer hub **164** and inner hub **162**, between rotor outer edge **40** and magnet **56**, and between magnet **56** and outer hub **164**. In this way, rotor poles **58** and magnets **56** are magnetically isolated on the outer diameter of rotor **36** and rotor poles **58** and magnets **56** are oriented at a predetermined diameter equal to a desired rotor diameter. Magnets **56** may be magnetized before insertion into the mold or may be magnetized after the molding process. Alternatively, rotor poles **58** and hubs **162** and **164** are located in the mold and a high-strength material with a high first processing temperature is injection molded in space **166** to form a central hub. Permanent magnets **56** are then inserted into radial apertures **46** defined between rotor poles **58**, and a lower second processing temperature material is molded in the remaining space around magnets **56**. This two-step molding process prevents performing the high processing temperature material injection while magnets **56** are in the mold, which may reduce the effectiveness of magnets **56**.

In the embodiments described above, electric motor **10** includes stator core **28**, which includes windings **32**. Typically, windings **32** are fabricated from copper, which makes up a significant part of the motor material cost. In one exemplary embodiment, windings **32** are formed from aluminum instead of copper. However, aluminum has approximately 60% of the resistivity of copper and lowers motor efficiency. One way to reduce the loss of efficiency is to increase the length of stator core **28** and rotor core **36**. However, increased motor length is undesirable from a material cost standpoint as well as an application standpoint (e.g. the longer motor may not fit in a desired user application). In order to reduce or recover the efficiency loss associated with aluminum windings while minimizing an increase in the length of motor **10**, radially embedded permanent magnet rotor **36** described above is used. Radially embedded permanent magnet rotor **36** generates more flux than other common rotor designs using

ferrite magnets. Radially embedded permanent magnet rotor **36** results in increased torque, which makes up for the loss in efficiency.

FIG. **20** illustrates another exemplary electric motor **200** that is similar to electric motor **10**, except electric motor **200** includes a rotor **202** having a different magnet arrangement than rotor core **36** above. In electric motor designs having rotor cores without radially embedded permanent magnets (e.g. surface mounted magnet rotors), motor efficiency is also reduced when copper windings are replaced with aluminum windings **32**. In order to overcome efficiency loss, electric motor **200** includes one or more permanent magnet **204** and aluminum windings **206**. In the exemplary embodiment, permanent magnet **204** is fabricated from a higher grade ferrite material that has remnance (Br) magnetic flux density higher than about 0.40 Tesla (about 4 K Gauss). Alternatively, permanent magnet **204** is fabricated from any material that enables electric motor **200** to increase flux density while using lower-cost materials.

Moreover, in the exemplary embodiment, windings **206** are designed or optimized so that the knee of the speed-torque curve of motor **200** is operating at substantially the full load operating point required by motor **200** for a desired application. The knee of the speed-torque curve is the motor speed at which the motor transitions from the voltage control region to the current control region. FIG. **21** illustrates an exemplary plot of speed and torque for motor **200**. The desired full load operating point is represented by point **208**. Line **210** plots the speed-torque curve of an electric motor without optimized windings. Point **212** represents the knee of the speed-torque curve of line **210**. Line **214** plots the speed-torque curve of electric motor **200** with optimized windings **206**. Point **216** represents the knee of the speed-torque curve of line **214**. In the exemplary embodiment, knee **216** of the curve is dropped closer to full load operating point **208** by adding more turns in windings **206**. By use of magnets **204** and/or optimized winding design of windings **206**, electric motor **200** is configured to recover all or at least a portion of the efficiency losses due to fabricating windings **206** from aluminum, without increasing the length of electric motor **200**.

FIG. **22** illustrates another exemplary electric motor **300** that is similar to electric motors **10** and **200**, except electric motor **300** includes a modified rotor **302** and windings **306**. In the exemplary embodiment, modified rotor **302** is a radially embedded permanent magnets rotor and replaces an original rotor (not shown). Alternatively, modified rotor **302** is a surface mounted permanent magnet rotor or an internal permanent magnet rotor. Motor **300** is a motor platform that is designed for operation at a typical design speed, which is the normal operating speed of a motor for a given rotor/stator construction. However, in the exemplary embodiment, motor **300** is desired to operate at a higher speed. Operation of motor **300** with the original rotor at the higher speed generates increased frequency, resulting in increased core loss and decreased efficiency. In the exemplary embodiment, motor **300** is fitted with modified rotor **302** to increase efficiency. Typically, rotor cores and stator cores have the same length. In the exemplary embodiment, rotor **302** is reduced in length compared to a stator core **28** so that rotor **302** generates less flux at the higher speeds. This enables motor **300** to operate at the higher desired operating speeds with increased efficiency with reduced core loss. Moreover, shorter length rotor **302** requires less material and reduces the cost of motor **300**. Additionally, flux density output of motor **300** is reduced by reducing the number of turns of windings **306**. In the exemplary embodiment, windings **306** are fabricated from copper and/or aluminum. Alternatively, windings **306** are fabricated

from any suitable material that enables motor **300** to function as described herein. In another embodiment, flux density output of motor **300** is reduced by using a lower remnance permanent magnet, a magnet with a reduced width, and/or a magnet with a shallower radial depth.

In the exemplary embodiment, the length of rotor **302** (compared to the original rotor) is dependent on the higher operation speed desired by the new application. For example, in one embodiment, motor **300** is originally designed to operate at a typical speed of 1,200 RPM and includes a stator and rotor with lengths of approximately 1.75 inches. The new motor application requires motor **300** to operate at 6,000 RPM, and motor **300** is fitted with modified, reduced-length rotor **302**, which is approximately 1 inch in length. As described above, motor **300** is modified with rotor **302** and/or windings **306** to enable motor **300** to be used for high speed applications without having to design a new motor platform specifically designed for the high speed application.

Described herein are exemplary methods, systems and apparatus utilizing lower cost materials in a permanent magnet motor that reduces or eliminates the efficiency loss caused by the lower cost material. Furthermore, the exemplary methods system and apparatus achieve increased efficiency while reducing or eliminating an increase of the length of the motor. The methods, system and apparatus described herein may be used in any suitable application. However, they are particularly suited for HVAC and pump applications.

Exemplary embodiments of the electric motor assembly are described above in detail. The electric motor and its components are not limited to the specific embodiments described herein, but rather, components of the systems may be utilized independently and separately from other components described herein. For example, the components may also be used in combination with other motor systems, methods, and apparatuses, and are not limited to practice with only the systems and apparatus as described herein. Rather, the exemplary embodiments can be implemented and utilized in connection with many other applications.

Although specific features of various embodiments of the disclosure may be shown in some drawings and not in others, this is for convenience only. In accordance with the principles of the disclosure, any feature of a drawing may be referenced and/or claimed in combination with any feature of any other drawing.

This written description uses examples to disclose the invention, including the best mode, and also to enable any person skilled in the art to practice the invention, including making and using any devices or systems and performing any incorporated methods. The patentable scope of the invention is defined by the claims, and may include other examples that occur to those skilled in the art. Such other examples are intended to be within the scope of the claims if they have structural elements that do not differ from the literal language of the claims, or if they include equivalent structural elements with insubstantial differences from the literal languages of the claims.

What is claimed is:

1. A permanent magnet rotor comprising:
at least one permanent magnet;

a substantially cylindrical rotor core comprising an outer edge and an inner edge defining a central opening, said rotor core having a radius R, said rotor core further comprising at least one pole and at least one radial aperture extending radially through said rotor core from said outer edge to a predetermined depth less than said radius, said at least one radial aperture configured to receive said at least one permanent magnet; and

15

at least one protrusion extending into said at least one radial aperture, said at least one protrusion positioned substantially along a bottom of said at least one radial aperture and configured to facilitate retention of said at least one permanent magnet within said at least one radial aperture; and
 wherein said predetermined depth of said at least one radial aperture is a depth between a minimum depth defined by the equation

$$D_{min} = \frac{(\pi * R)}{n},$$

and a maximum depth defined by the equation

$$D_{max} = R - \frac{0.5t}{\tan\left(\frac{180}{n}\right)},$$

wherein n is the number of poles of the rotor core and t is the thickness of said at least one permanent magnet.

2. The rotor of claim 1, further comprising a shaft extending through said central opening, said at least one permanent magnet positioned within said rotor core radially about said shaft and an axis of rotation of said rotor core.

3. The rotor of claim 1, wherein said rotor core further comprises at least one of six poles, eight poles, ten poles, twelve poles, and fourteen poles, said poles positioned radially about said central opening, and a radial aperture positioned between each of said poles.

4. The electric machine of claim 1, wherein said at least one protrusion comprises a first pair of protrusions and a second pair of protrusions, said first and second pair of protrusions extending into said at least one radial aperture from opposed walls of said radial aperture.

5. The electric machine of claim 4, wherein said first pair of protrusions is positioned substantially at a bottom of said at least one radial aperture and said second pair of protrusions is positioned substantially along said outer edge of said rotor core.

6. The rotor core of claim 1, wherein at least one of said at least one radial aperture and said permanent magnet is tapered.

7. An electric machine comprising:
 a machine housing;

a stator disposed at least partially within said machine housing; and

a rotor disposed at least partially within said machine housing, said rotor configured to rotate with respect to said stator, said rotor comprising:

at least one permanent magnet;

a substantially cylindrical rotor core comprising an outer edge and an inner edge defining a central opening, said rotor core having a radius R, said rotor further comprising at least one pole and at least one radial aperture extending radially through said rotor core from said outer edge to a predetermined depth less than said radius, said at least one radial aperture configured to receive said at least one permanent magnet; and

at least one protrusion extending into said at least one radial aperture, said at least one protrusion positioned substantially along a bottom of said at least one radial

16

aperture and configured to facilitate retention of said at least one permanent magnet within said at least one radial aperture,
 wherein said predetermined depth of each of said plurality of radial apertures is between a minimum depth defined by the equation

$$D_{min} = \frac{(\pi * R)}{n},$$

and a maximum depth defined by the equation

$$D_{max} = R - \frac{0.5t}{\tan\left(\frac{180}{n}\right)},$$

wherein n is the number of poles of the rotor core and t is the thickness of said at least one permanent magnet.

8. The electric machine of claim 7, wherein said rotor comprises at least one of six poles, eight poles, twelve poles, and fourteen poles.

9. The electric machine of claim 7, wherein said electric machine further comprises at least one of a sinusoidal electronic control drive and a trapezoidal electronic control drive.

10. The electric machine of claim 7, wherein said stator comprises at least one tooth and an aluminum winding wound around said at least one tooth, wherein said rotor core is a radially embedded permanent magnet rotor configured to generate increased flux to reduce efficiency loss due to said aluminum winding.

11. The electric machine of claim 10, wherein said winding is at least one of a concentrated type winding and an overlapped type winding.

12. The electric machine of claim 7, wherein said electric machine is at least one of a single-phase motor and a three-phase motor.

13. The electric machine of claim 7, further comprising a shaft extending through said central opening, said at least one permanent magnet positioned within said rotor core radially about said shaft and an axis of rotation of said rotor.

14. The electric machine of claim 7, wherein said at least one protrusion comprises a first pair of protrusions and a second pair of protrusions, said first and second pair of protrusions extending into said at least one radial aperture from opposed walls of said radial aperture.

15. The electric machine of claim 14, wherein said first pair of protrusions is positioned substantially at a bottom of said at least one radial aperture and said second pair of protrusions is positioned substantially along said outer edge of said rotor core.

16. The electric machine of claim 7, wherein at least one of said at least one radial aperture and said permanent magnet is tapered.

17. A method of manufacturing a permanent magnet rotor, the method comprising:

providing a rotor core comprising at least one pole, an outer edge, and an inner edge defining a central opening, the rotor core having a radius R;

forming at least one radial aperture radially through the rotor core from the outer edge to a predetermined depth less than the radius;

forming at least one protrusion extending into the at least one radial aperture, the at least one protrusion positioned

17

substantially at a bottom of the at least one radial aperture and configured to facilitate retention of the at least one permanent magnet within the at least one radial aperture, wherein the predetermined depth of the at least one radial aperture is a depth between a minimum depth 5 defined by the equation

$$D_{min} = \frac{(\pi * R)}{n}, \quad 10$$

and a maximum depth defined by the equation

$$D_{max} = R - \frac{0.5t}{\tan\left(\frac{180}{n}\right)}, \quad 15$$

wherein n is the number of poles of the rotor core and t 20 is the thickness of the permanent magnet; and inserting a permanent magnet into the at least one radial aperture.

18. The method of claim **17**, wherein forming at least one protrusion comprises forming a first pair of protrusions and a 25 second pair of protrusions, the first and second pair of protrusions extending into at least one radial aperture from opposed walls of the radial aperture.

19. The method of claim **17**, wherein at least one of the at least one radial aperture and the permanent magnet is tapered. 30

* * * * *

18