

US009235166B2

(12) **United States Patent**  
**Shimura**

(10) **Patent No.:** **US 9,235,166 B2**  
(45) **Date of Patent:** **Jan. 12, 2016**

(54) **HEATER AND IMAGE HEATING DEVICE MOUNTED WITH HEATER**

(71) Applicant: **CANON KABUSHIKI KAISHA**,  
Tokyo (JP)

(72) Inventor: **Yasuhiro Shimura**, Yokohama (JP)

(73) Assignee: **Canon Kabushiki Kaisha**, Tokyo (JP)

(\* ) Notice: Subject to any disclaimer, the term of this patent is extended or adjusted under 35 U.S.C. 154(b) by 0 days.

(21) Appl. No.: **14/029,619**

(22) Filed: **Sep. 17, 2013**

(65) **Prior Publication Data**  
US 2014/0076878 A1 Mar. 20, 2014

(30) **Foreign Application Priority Data**  
Sep. 19, 2012 (JP) ..... 2012-205713

(51) **Int. Cl.**  
**G03G 15/20** (2006.01)  
**H05B 3/03** (2006.01)  
**H05B 3/26** (2006.01)

(52) **U.S. Cl.**  
CPC ..... **G03G 15/2003** (2013.01); **G03G 15/2042** (2013.01); **G03G 15/2053** (2013.01); **H05B 3/03** (2013.01); **G03G 2215/2035** (2013.01); **H05B 3/26** (2013.01); **H05B 2203/007** (2013.01); **H05B 2203/02** (2013.01)

(58) **Field of Classification Search**  
None  
See application file for complete search history.

(56) **References Cited**  
U.S. PATENT DOCUMENTS

5,915,146 A \* 6/1999 Kusaka et al. .... 399/68  
6,084,208 A \* 7/2000 Okuda et al. .... 219/216

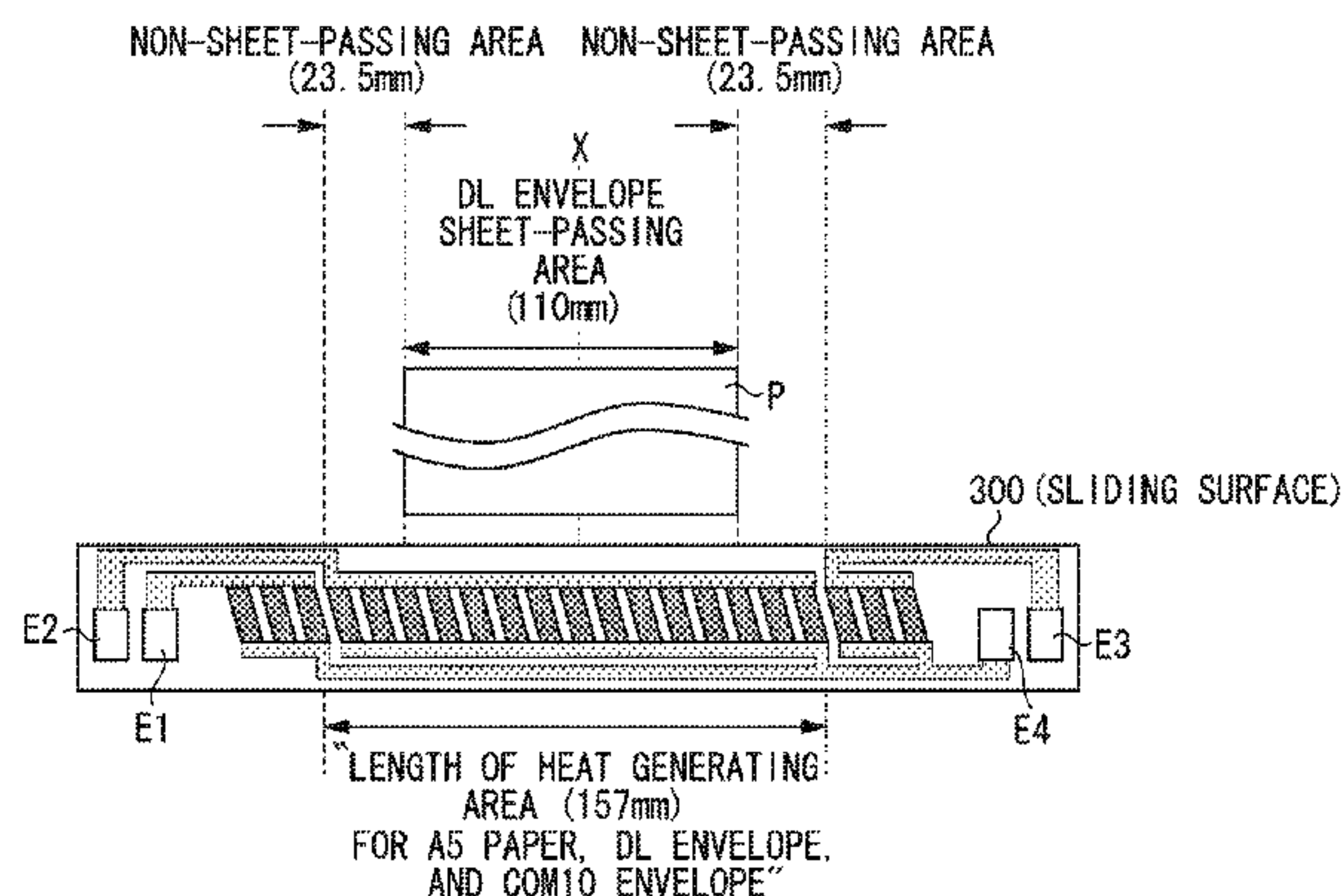

6,456,819	B1 *	9/2002	Abe et al. ....	399/329
7,228,082	B1 *	6/2007	Davidson et al. ....	399/45
8,126,383	B2 *	2/2012	Kagawa ....	399/329
8,150,304	B2 *	4/2012	Kagawa et al. ....	399/329
8,175,508	B2 *	5/2012	Kageyama ....	399/329
8,295,753	B2 *	10/2012	Kagawa ....	399/329
8,471,178	B2 *	6/2013	Taniguchi et al. ....	219/216
8,592,726	B2 *	11/2013	Tsuruya et al. ....	219/216
2003/0185605	A1 *	10/2003	Okabayashi ....	399/329
2009/0230114	A1 *	9/2009	Taniguchi et al. ....	219/216
2010/0142986	A1 *	6/2010	Davidson et al. ....	399/69

(Continued)

**FOREIGN PATENT DOCUMENTS**

CN	101561655	A	10/2009
CN	102667638	A	9/2012
JP	2005-209493	A	8/2005

(Continued)

**OTHER PUBLICATIONS**

JP 2005-209493A, Nakahara, Aug. 2005, partial translation.\*

(Continued)

*Primary Examiner* — Joseph M Pelham

(74) *Attorney, Agent, or Firm* — Canon USA Inc. IP Division

(57) **ABSTRACT**

A heater of the present invention includes jointed heat generating resistors having a positive temperature characteristic of resistance and provided between a first conductive element and a second conductive element on a substrate in a longitudinal direction of the substrate, and a plurality of heating blocks provided in the longitudinal direction, each of which is a set of the first conductive element, the second conductive element, and the heat generating resistor, and power supplied to at least one of the plurality of heating blocks can be controlled independent of other heating blocks.

**36 Claims, 12 Drawing Sheets**

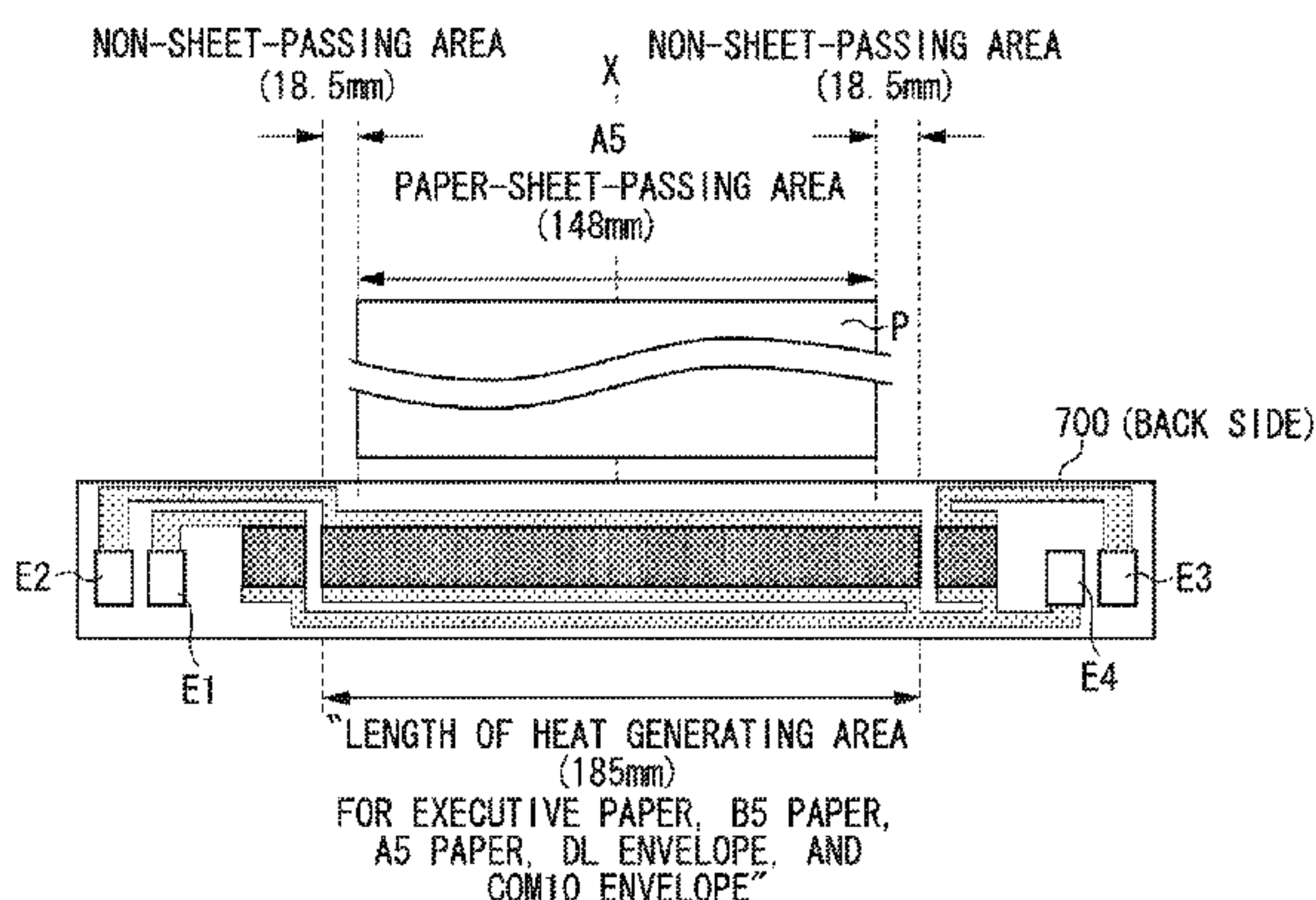

(56)

**References Cited**

U.S. PATENT DOCUMENTS

2011/0164906 A1\* 7/2011 Ishida et al. .... 399/329  
2012/0230719 A1\* 9/2012 Matsumoto ..... 399/69

FOREIGN PATENT DOCUMENTS

JP 2008166096 A \* 7/2008  
JP 2010002857 A \* 1/2010

JP 2011-060657 A 3/2011  
JP 2011-129483 A 6/2011  
JP 2011-151003 A 8/2011  
KR 20120056861 A 6/2012  
WO 2011/030440 A1 3/2011

OTHER PUBLICATIONS

JP-2008-166096A, Karibe et al, Jul. 2008, partial translation.\*

\* cited by examiner

FIG. 1

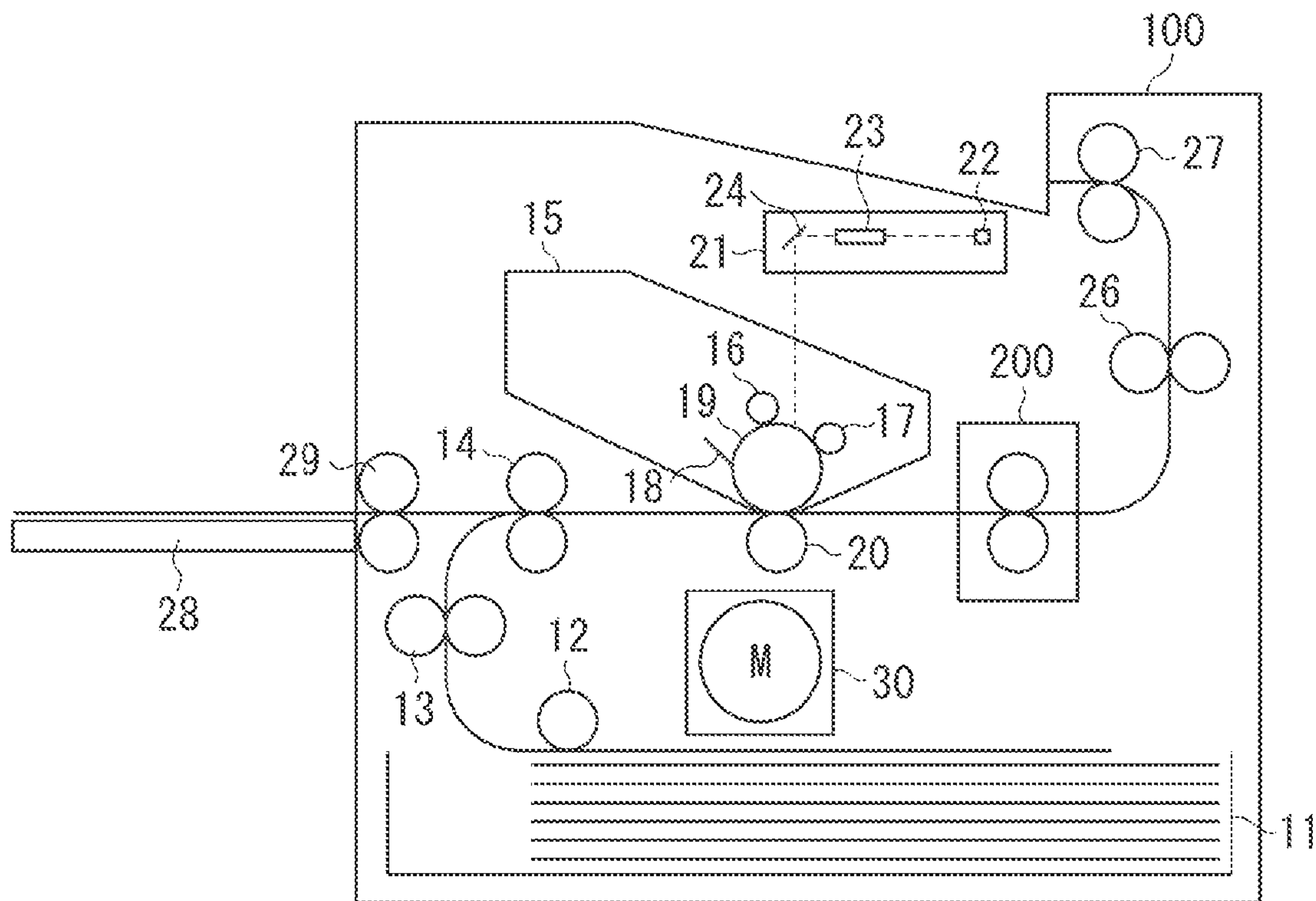
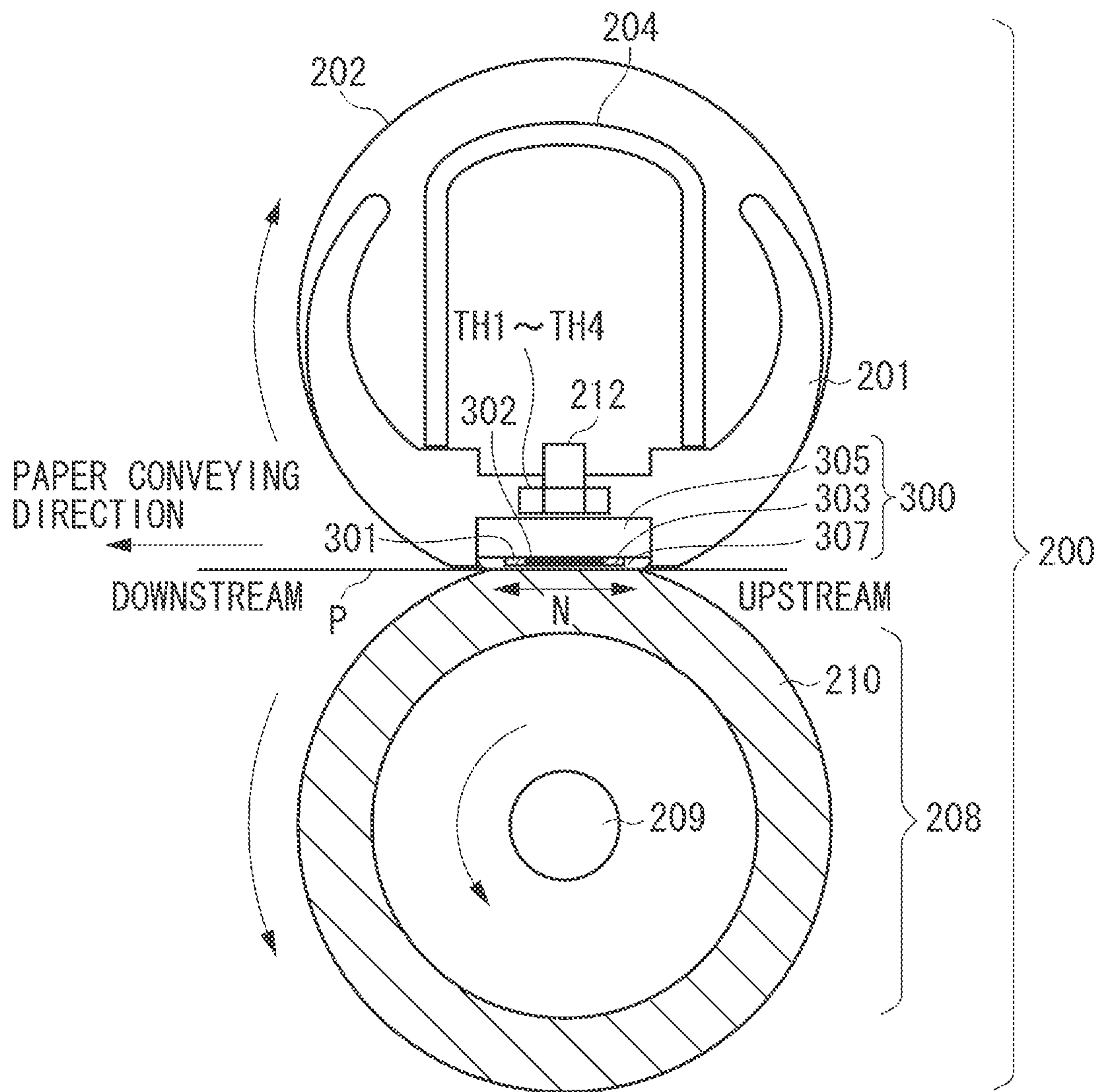

FIG. 2





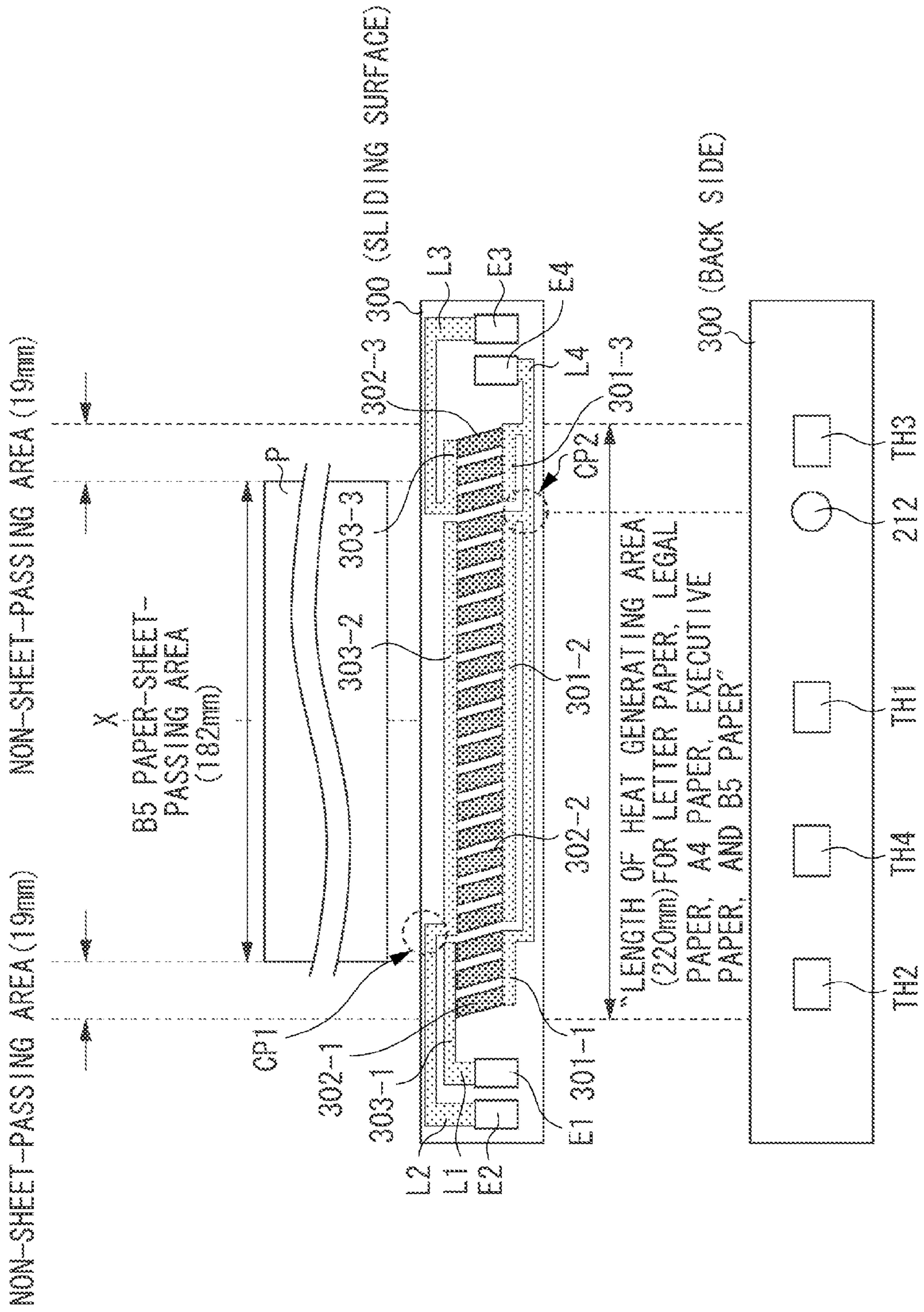

FIG. 3A

FIG. 3B

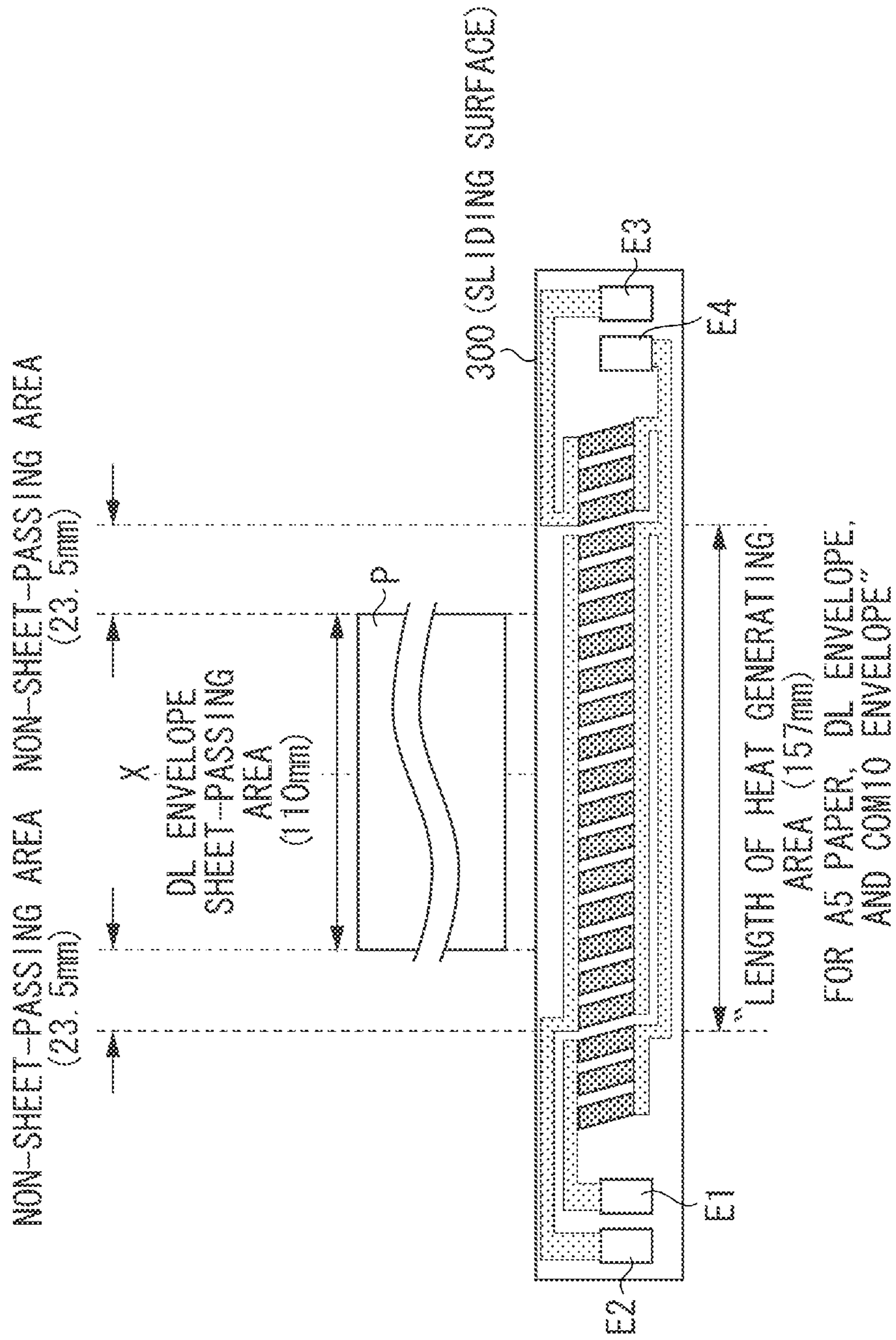

FIG. 4

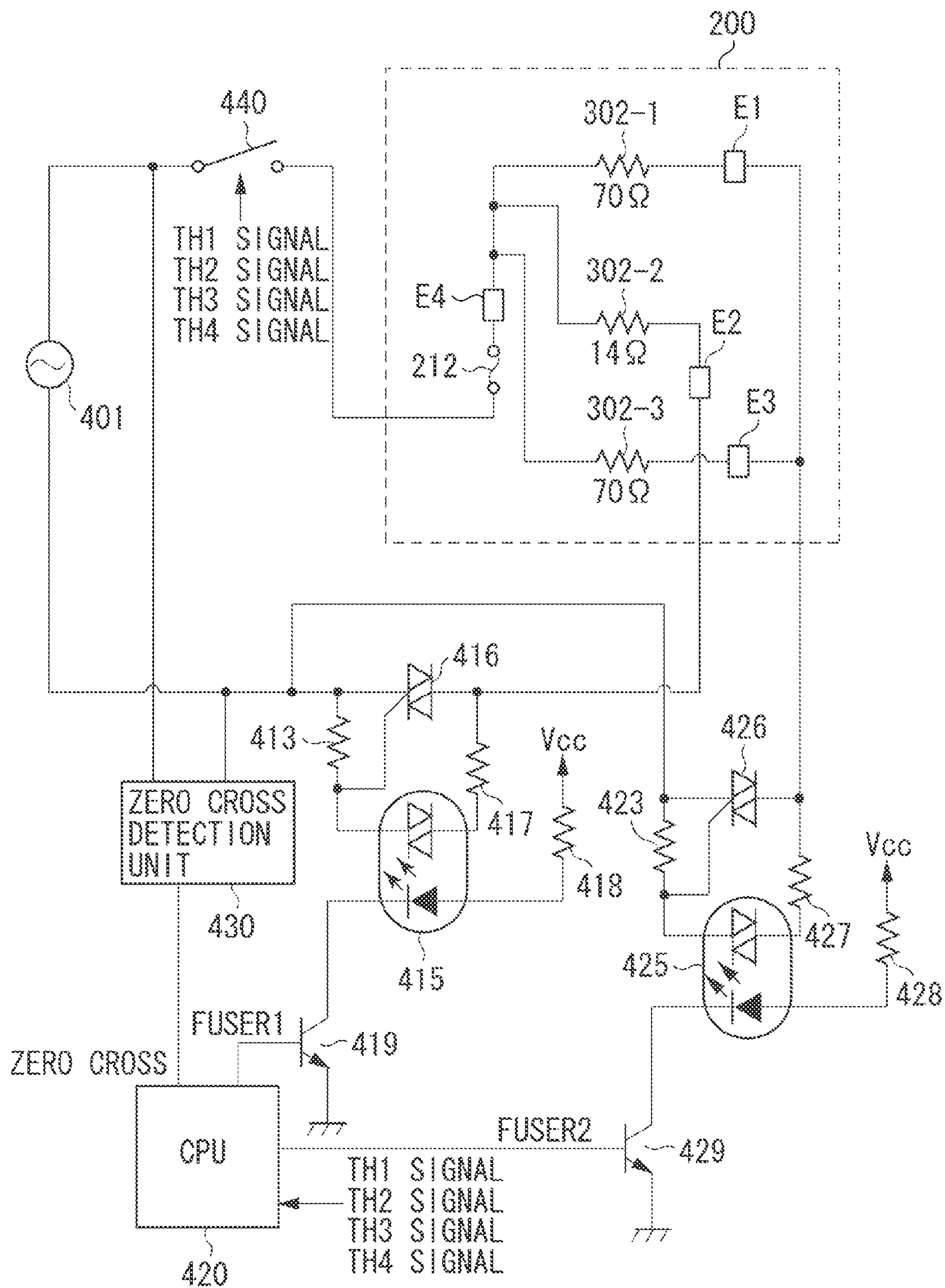



FIG. 5

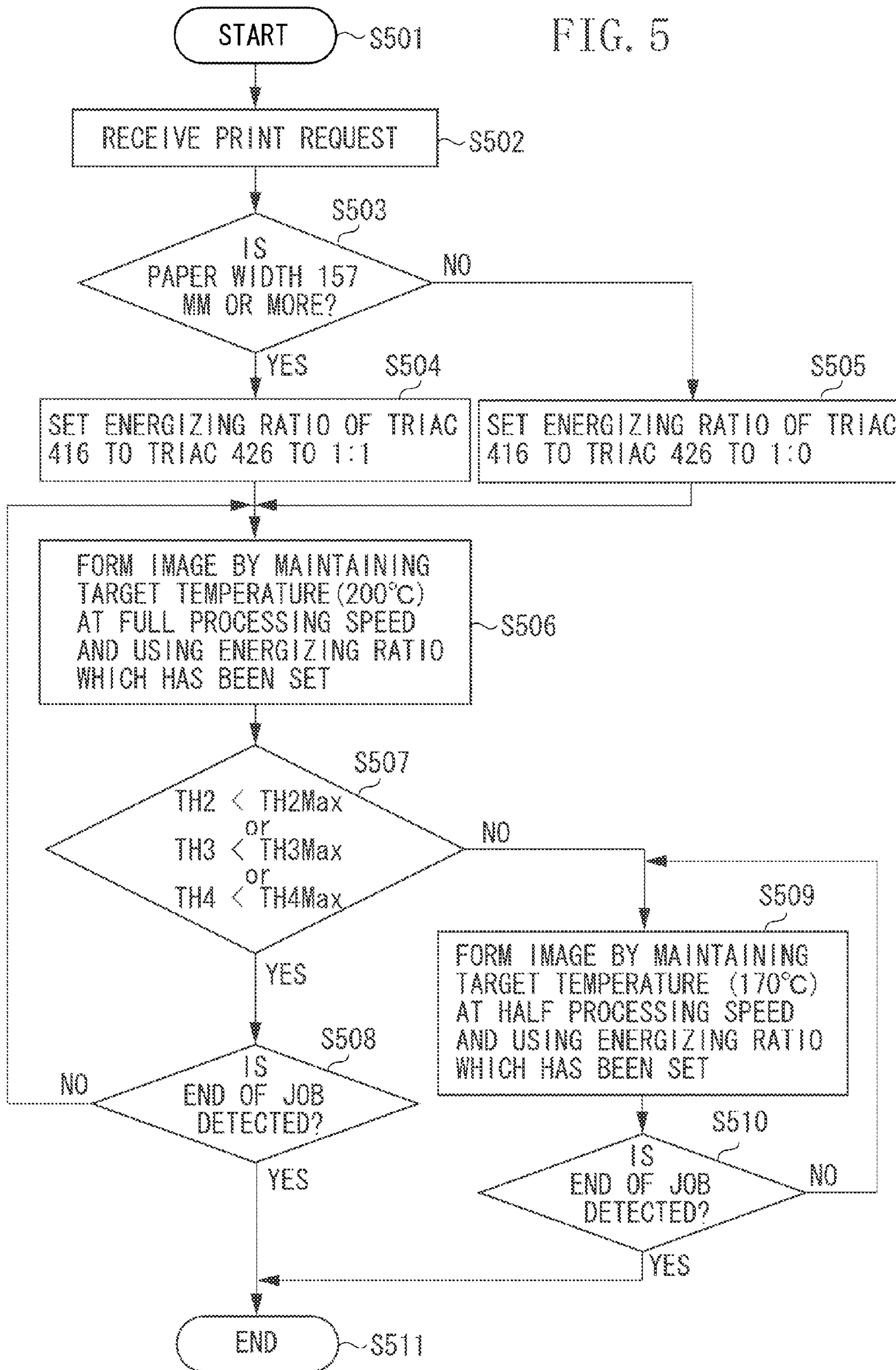





FIG. 7A

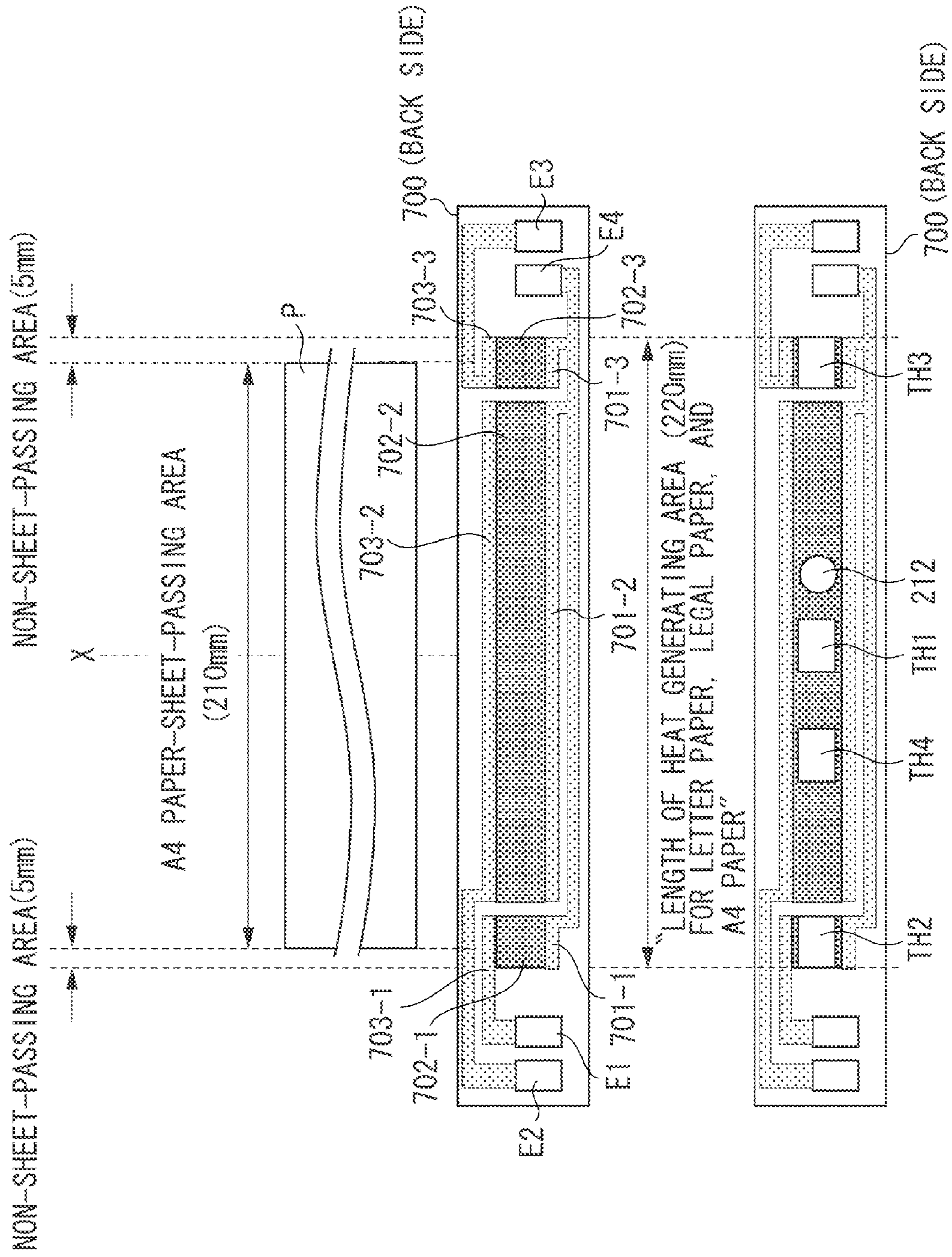

FIG. 7B

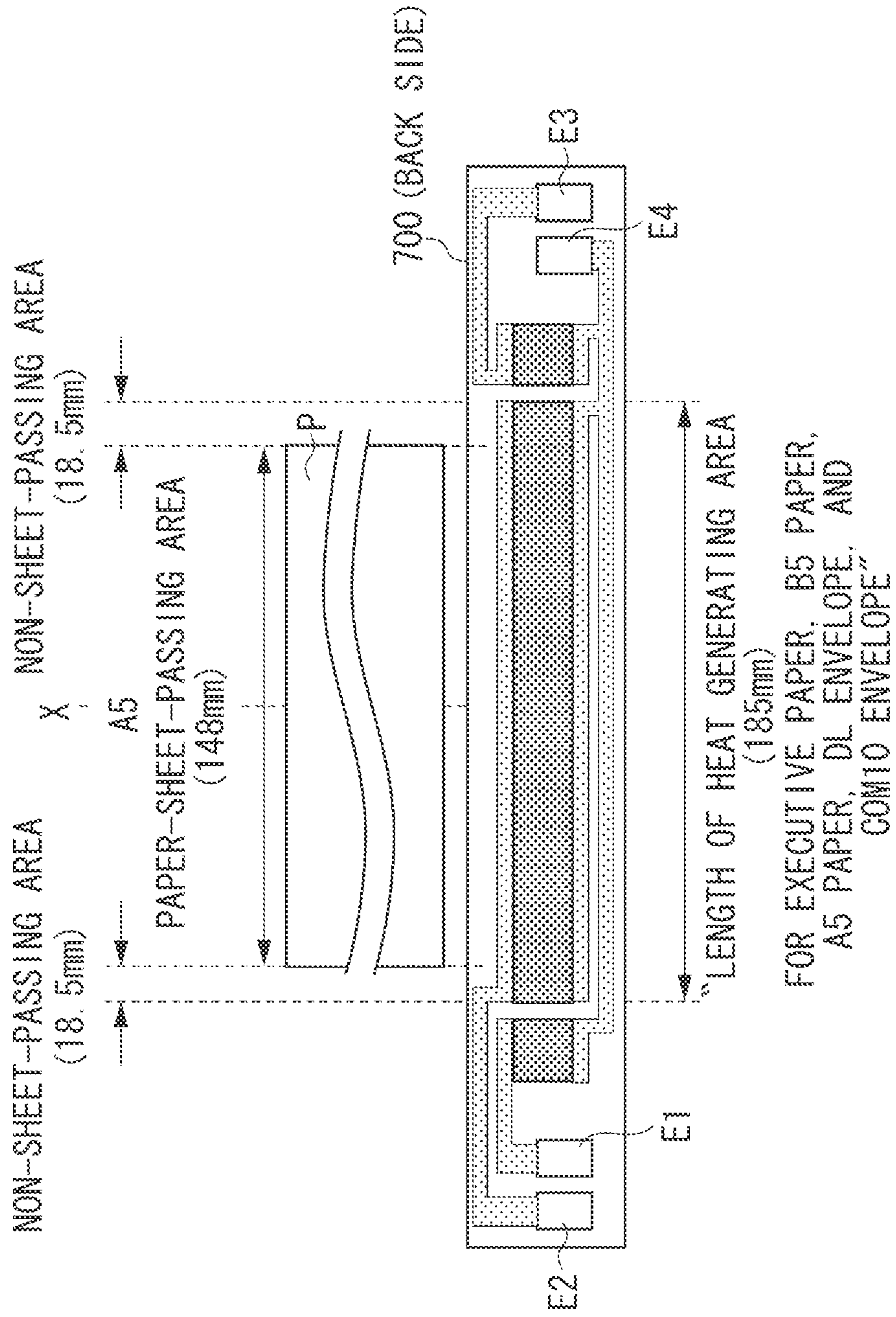

FIG. 8

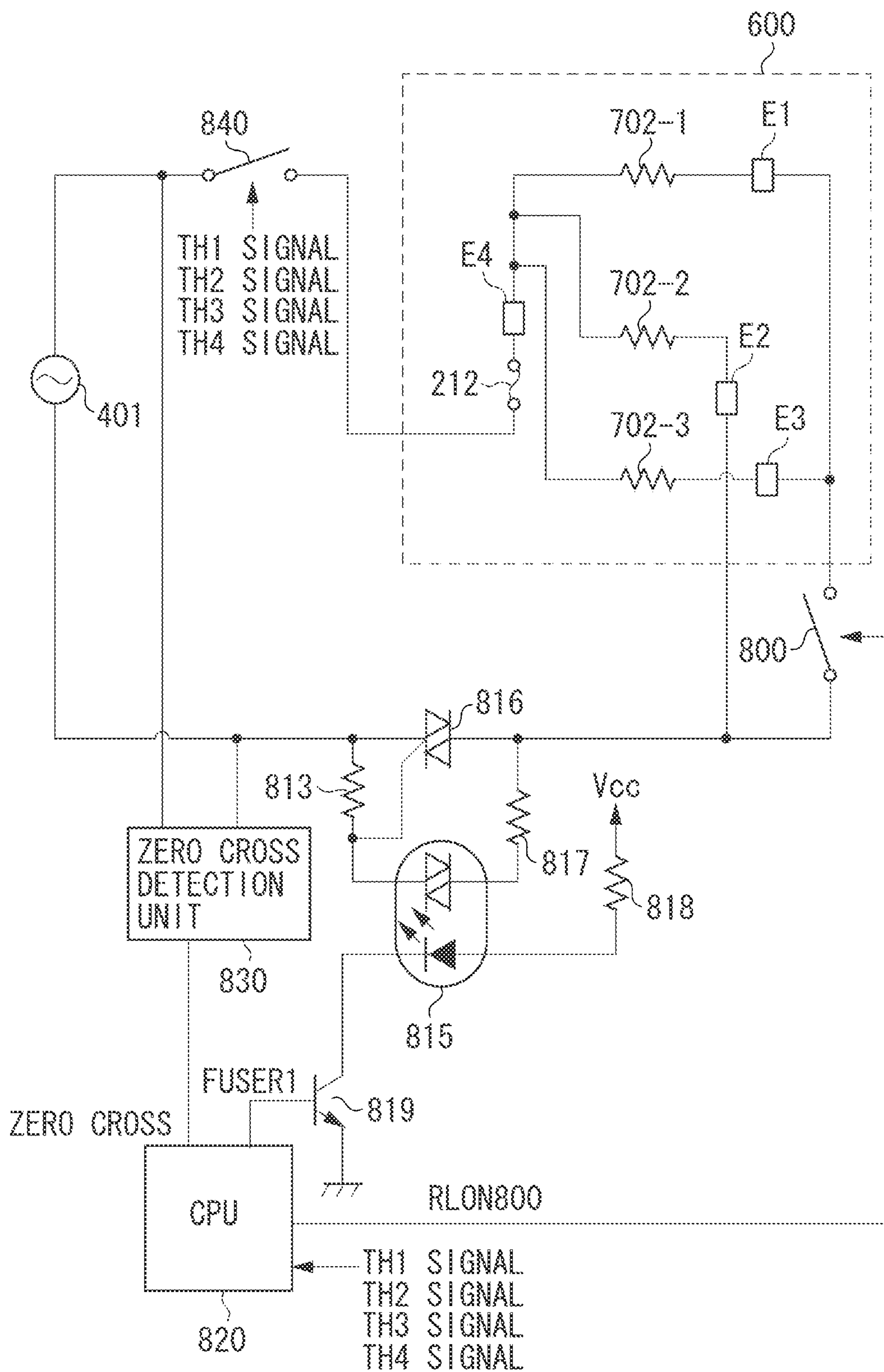



FIG. 9

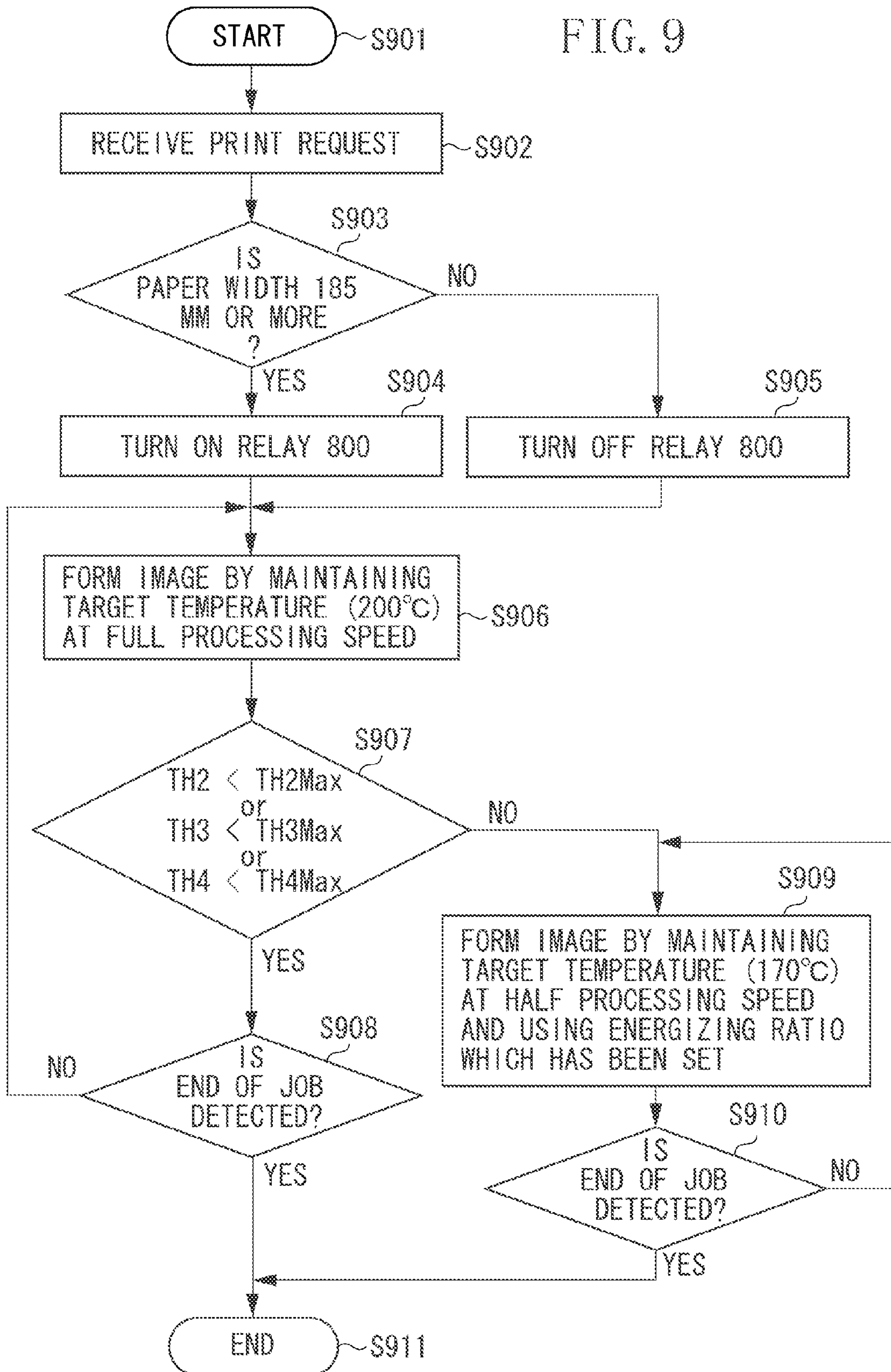

FIG. 10A

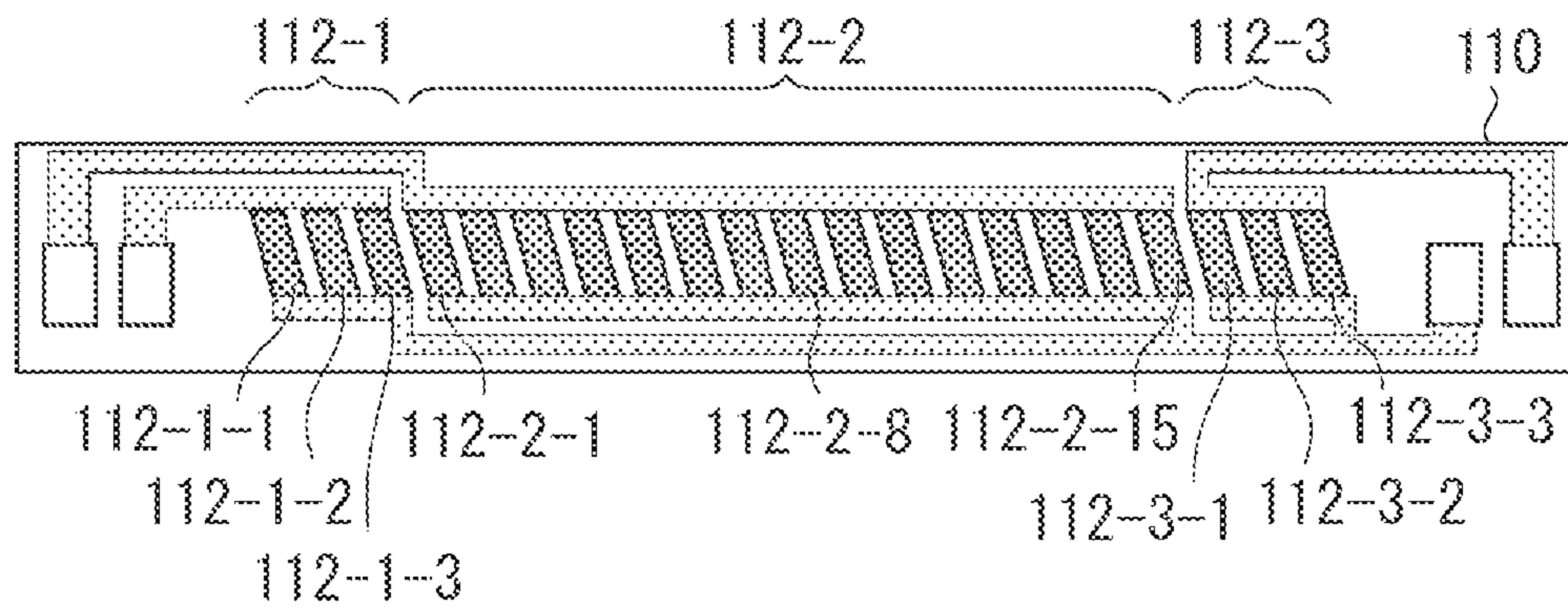

FIG. 10B

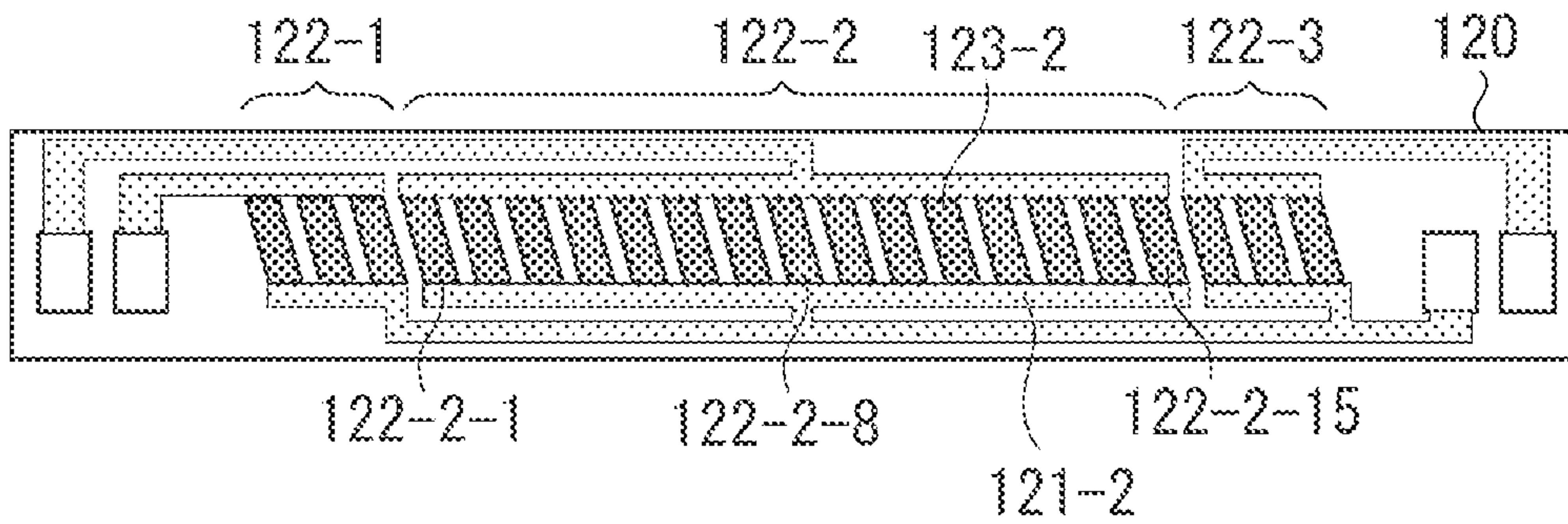
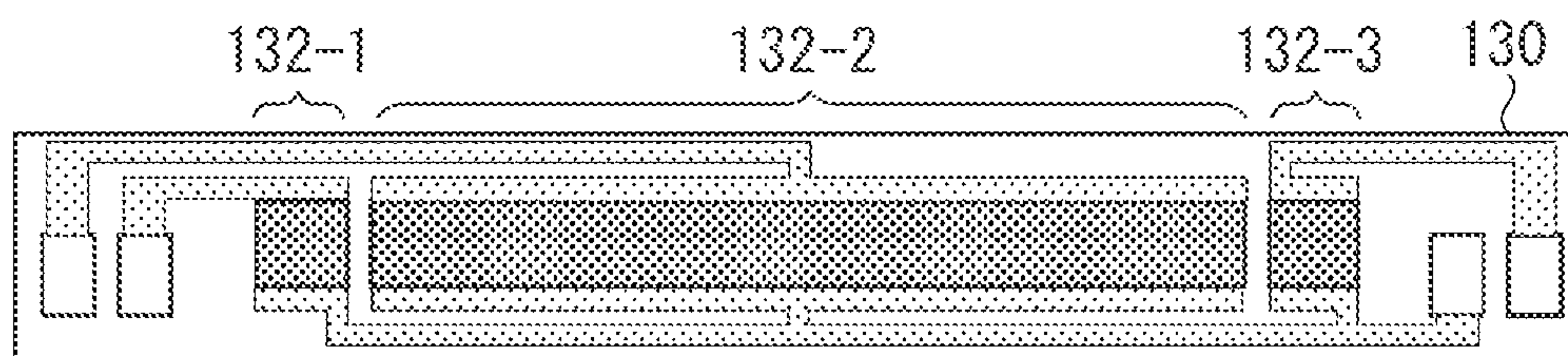

FIG. 10C





1

## HEATER AND IMAGE HEATING DEVICE MOUNTED WITH HEATER

### BACKGROUND OF THE INVENTION

#### 1. Field of the Invention

The present invention relates to a heater useful for an image heating device mounted on an image forming apparatus such as an electrophotographic copier or an electrophotographic printer, and an image heating device mounting the heater.

#### 2. Description of the Related Art

An image heating device mounted on a copier or a printer includes an endless belt, a ceramic heater which contacts the inner surface of the endless belt, and a pressure roller which forms a fixing nip portion with the ceramic heater via the endless belt. If small size paper is continuously printed by an image forming apparatus which is mounted with such an image heating device, the temperature of a non-sheet-passing portion in the longitudinal direction of the fixing nip portion gradually increases (temperature rise at non-sheet-passing portion). If the temperature of the non-sheet-passing portion becomes too high, it may cause damage to the components of the apparatus. Further, if large size paper is printed in a state where the temperature at the non-sheet-passing portion is high, high temperature offset of toner may occur at the area corresponding to the non-sheet-passing portion of small size paper.

As one method for preventing such temperature rise at the non-sheet-passing portion, Japanese Patent Application Laid-Open No. 2011-151003 discusses a method which uses two conductive elements and a heat generating resistor formed by a material having a positive temperature characteristic of resistance. The heat generating resistor is mounted on a ceramic substrate and the two conductive elements are arranged at both ends of the substrate in the widthwise direction of the substrate so that the current passes the heat generating resistor in the widthwise direction of the heater. The widthwise direction of the heater is the conveying direction of the paper. This flow of current is hereinafter referred to as power feeding in the paper conveying direction. The resistance of the heat generating resistor at the non-sheet-passing portion increases when the temperature of the non-sheet-passing portion increases. Thus, the heat generation at the non-sheet-passing portion can be decreased by reducing the electric current that passes through the heat generating resistor at the non-sheet-passing portion. The resistance of a device having the positive temperature characteristic of resistance increases when the temperature increases. Such characteristic is hereinafter referred to as positive temperature coefficient (PTC).

However, even if a heater configured as described above is used, the electric current flows through the heat generating resistor positioned at the non-sheet-passing portion and heat is generated.

### SUMMARY OF THE INVENTION

The present invention is directed to providing a heater which can effectively prevent temperature rise at a non-sheet-passing portion. The present invention is directed to providing an image heating device mounted with a heater which can effectively prevent temperature rise at a non-sheet-passing portion.

According to an aspect of the present invention, a heater includes a substrate, a first conductive element provided on the substrate along a longitudinal direction of the substrate, a second conductive element provided on the substrate along

2

the longitudinal direction at a position different from the first conductive element in a widthwise direction of the substrate, and a heat generating resistor provided between the first conductive element and the second conductive element and showing a positive temperature characteristic of resistance, which generates heat when power is supplied via the first conductive element and the second conductive element, and a plurality of heating blocks each of which includes a set of the first conductive element, the second conductive element, and the heat generating resistor is provided in the longitudinal direction, and power control of at least one of the plurality of heating blocks can be performed independent of other heating blocks, and according to another aspect of the present invention, an image heating device includes a heater, a connector connected to an electrode of the heater and configured to supply power to the heater, and the heater includes, a substrate, a first conductive element provided on the substrate along a longitudinal direction of the substrate, a second conductive element provided on the substrate along the longitudinal direction at a position different from the first conductive element in a widthwise direction of the substrate, and a heat generating resistor provided between the first conductive element and the second conductive element and including a positive temperature characteristic of resistance associated with heat generation when power is supplied via the first conductive element and the second conductive element, and a plurality of heating blocks each of which includes a set of the first conductive element, the second conductive element, and the heat generating resistor which is provided in the longitudinal direction, and power control of at least one of the plurality of heating blocks can be performed independent of other heating blocks.

Further features and aspects of the present invention will become apparent from the following detailed description of exemplary embodiments with reference to the attached drawings.

### BRIEF DESCRIPTION OF THE DRAWINGS

The accompanying drawings, which are incorporated in and constitute a part of the specification, illustrate exemplary embodiments, features, and aspects of the invention and, together with the description, serve to explain the principles of the invention.

FIG. 1 is a cross-sectional view of an image forming apparatus.

FIG. 2 is a cross-sectional view of an image heating device according to a first exemplary embodiment of the present invention.

FIGS. 3A and 3B illustrate configurations of a heater according to the first exemplary embodiment.

FIG. 4 is a heater control circuit diagram according to the first exemplary embodiment.

FIG. 5 is a flowchart illustrating the heater control according to the first exemplary embodiment.

FIG. 6 is a cross-sectional view of the image heating device according to a second exemplary embodiment of the present invention.

FIGS. 7A and 7B illustrate configurations of the heater according to the second exemplary embodiment.

FIG. 8 is a heater control circuit diagram according to the second exemplary embodiment.

FIG. 9 is a flowchart illustrating the heater control according to the second exemplary embodiment.



FIGS. 10A, 10B, and 10C illustrate alternate versions of the heater.

#### DESCRIPTION OF THE EMBODIMENTS

Various exemplary embodiments, features, and aspects of the invention will be described in detail below with reference to the drawings.

FIG. 1 is a cross-sectional view of a laser printer (image forming apparatus) 100 using an electrophotographic recording technique. When a print signal is generated, a laser beam is emitted from a scanner unit 21. The laser beam is modulated according to image information. A photosensitive member 19, which is charged to a predetermined polarity by a charge roller 16, is scanned by the laser beam. Accordingly, an electrostatic latent image is formed on the photosensitive member 19. Toner is supplied to this electrostatic latent image from a developing unit 17 and a toner image is formed on the photosensitive member 19 according to the image information. On the other hand, a recording material (recording paper) P, set in a sheet cassette 11, is picked-up by a pickup roller 12 one sheet at a time, and conveyed to a registration roller 14 by a roller 13. Further, the recording material P is conveyed to a transfer position by the registration roller 14 at timing the toner image on the photosensitive member 19 reaches the transfer position. The transfer position is formed by the photosensitive member 19 and a transfer roller 20.

The toner image on the photosensitive member 19 is transferred to the recording material P while the recording material P passes the transfer position. Then, heat is applied to the recording material P by an image heating device 200 and the toner image is fixed to the recording material P. The recording material P with the fixed toner image is discharged on a tray provided at the upper portion of the printer by rollers 26 and 27. The laser printer 100 also includes a cleaner 18 which cleans the photosensitive member 19 and a paper feeding tray 28 which is a manual feed tray having a pair of regulating plates. The user can adjust the width of the paper feeding tray 28 to the size of the recording material P by using the pair of regulating plates. The paper feeding tray 28 is used when the recording material P of a size other than the standard size is printed. A pick up roller 29 picks up the recording material P from the paper feeding tray 28. A motor 30 drives the image heating device 200. The photosensitive member 19, the charge roller 16, the scanner unit 21, the developing unit 17, and the transfer roller 20 constitute an image forming unit which forms an unfixed image on the recording material P.

The laser printer 100 according to the present embodiment can print an image on paper of various sizes. In other words, the laser printer 100 can print an image on Letter paper (approximately 216 mm×279 mm), Legal paper (approximately 216 mm×356 mm), A4 paper (210 mm×297 mm), Executive paper (approximately 184 mm×267 mm), JIS B5 paper (182 mm×257 mm), and A5 paper (148 mm×210 mm) set in the sheet cassette 11.

Further, the laser printer 100 can print an image on non-standard paper such as a DL envelope (110 mm×220 mm) and a Com10 envelope (approximately 105 mm×241 mm) set in the paper feeding tray 28. Basically, the laser printer 100 is a printer which feeds paper by short edge feeding. When the paper is fed by short edge feeding, the long side of the sheet is in parallel with the sheet-conveying direction. The largest size of paper (i.e., paper with the largest width) out of the standard paper sizes printable by the laser printer 100 according to the apparatus brochure is Letter paper and Legal paper with a width of approximately 216 mm. According to the

present embodiment, paper with a width smaller than the largest size printable by the laser printer 100 is referred to as small size paper.

FIG. 2 is a cross-sectional view of the image heating device 200. The image heating device 200 includes a film 202, a heater 300, and a pressure roller 208. The film 202 is an endless belt. The heater 300 contacts the inner side of the film 202. The pressure roller 208 forms a nip portion forming member which forms a fixing nip portion N via the film 202 together with the heater 300. The material of the base layer of the film 202 is a heat-resistant resin such as a polyimide or a metal such as stainless steel. The pressure roller 208 includes a cored bar 209 made of steel or aluminum, and an elastic layer 210 formed by a material such as a silicone rubber. The heater 300 is held by a holding member 201 which is made of a heat resistant resin. The holding member 201 has a guiding function and it guides the rotation of the film 202. When the pressure roller 208 receives power from the motor 30, it rotates in the direction of the arrow. Further, the film 202 rotates following the rotation of the pressure roller 208. At the fixing nip portion N, heat is applied to the recording material P. Thus, the unfixed toner image is fixed to the recording material P while the recording material P is conveyed through the fixing nip portion N.

The heater 300 includes a heater substrate 305 which is ceramic, a first conductive element 301, and a second conductive element 303. The first conductive element 301 is provided on the heater substrate 305 along the longitudinal direction of the substrate. The second conductive element 303 is also provided on the heater substrate 305 along the longitudinal direction of the substrate but at a position different from the first conductive element 301 in the widthwise direction of the substrate. Further, the heater 300 includes a heat generating resistor 302. The heat generating resistor 302 is provided between the first conductive element 301 and the second conductive element 303 and has a positive temperature characteristic of resistance. The heat generating resistor 302 generates heat according to the power supplied via the first conductive element 301 and the second conductive element 303. Furthermore, the heater 300 includes a surface protection layer 307 which covers the heat generating resistor 302, the first conductive element 301, and the second conductive element 303. The surface protection layer 307 has an insulation property. According to the present embodiment, glass is used for the surface protection layer 307. As temperature detecting elements, thermistors TH1, TH2, TH3, and TH4 contact the back side of the heater substrate 305 in the sheet-passing area of the laser printer 100. In addition to the thermistors TH1 to TH4, a safety element 212 also contacts the back side of the heater substrate 305. The safety element 212 is, for example, a thermo switch or a thermal fuse. When abnormal heating of the heater occurs, the safety element 212 is turned on and the power supplied to the heater is stopped. A metal stay 204 exerts a force of a spring (not illustrated) on the holding member 201.

FIGS. 3A and 3B illustrate heater configurations of a first exemplary embodiment. First, the configuration of the heater and the effect of reducing the temperature rise at the non-sheet-passing portion will be described with reference to FIG. 3A.

The heater 300 includes a plurality of heating blocks in the longitudinal direction of the substrate. One heating block is a set of components which are the first conductive element 301, the second conductive element 303, and the heat generating resistor 302. The heater 300 according to the present embodiment includes a total of three heating blocks (a heating block 302-1, a heating block 302-2, a heating block 302-3) provided



at the center and both ends of the heater **300** in the longitudinal direction of the substrate. Thus, the first conductive element **301** provided along the longitudinal direction of the substrate is divided into three conductive elements (first conductive elements **301-1**, **301-2**, and **301-3**). Similarly, the second conductive element **303** provided along the longitudinal direction of the substrate is divided into three conductive elements (second conductive elements **303-1**, **303-2**, and **303-3**). Connectors for power supply provided on the main body side of the image heating device **200** are connected to electrodes **E1**, **E2**, **E3**, and **E4**.

The heating block **302-1**, which is arranged at one end of the heater **300**, includes a plurality of heat generating resistors (three heat generating resistors according to the present embodiment) between the first conductive element **301-1** and the second conductive element **303-1**. The heat generating resistors are electrically connected by parallel connection. The three heat generating resistors of the heating block **302-1** receive power from the electrode **E1** and the electrode **E4** via the first conductive element **301-1** and the second conductive element **303-1**.

The heating block **302-2**, which is at the center portion of the heater **300**, includes a plurality of heat generating resistors (15 heat generating resistors according to the present embodiment) between the first conductive element **301-2** and the second conductive element **303-2**. The heat generating resistors are electrically connected by parallel connection. The 15 heat generating resistors of the heating block **302-2** receive power from the electrode **E2** and the electrode **E4** via the first conductive element **301-2** and the second conductive element **303-2**.

The heating block **302-3**, which is at the other end of the heater **300**, includes a plurality of heat generating resistors (three heat generating resistors according to the present embodiment) between the first conductive element **301-3** and the second conductive element **303-3**. The heat generating resistors are electrically connected by parallel connection. The three heat generating resistors of the heating block **302-3** receive power from the electrode **E3** and the electrode **E4** via the first conductive element **301-3** and the second conductive element **303-3**. Each of a total of 21 heat generating resistors has a positive temperature characteristic of resistance (PTC).

In this manner, a plurality of heating blocks, each of which is a set of components (the first conductive element **301**, the second conductive element **303**, and the heat generating resistor **302**), are provided in the heater **300** in the longitudinal direction of the substrate. The heating blocks are configured such that power control of at least one of them can be performed independently from the power control of other heating blocks.

According to the present embodiment, by devising the connection positions of the conductive elements and power supply lines (**L1** to **L4**) which extend from the electrodes (**E1** to **E4**), uniform heat distribution of the heater **300** in the longitudinal direction of the substrate can be realized. More precisely, with respect to each of the three heating blocks, power is supplied from the diagonal side of the heating block. This power feeding method is hereinafter referred to as diagonal power feeding.

The diagonal power feeding will now be described by taking the heating block **302-2** as an example. In FIG. 3A, power is supplied in a diagonal direction of the heating block from a connection position **CP2** and a connection position **CP1**. The connection position **CP2** is a connection position of the first conductive element **301-2** and the power supply line **L4** at the lower right portion of the heating block **302-2**. The connection position **CP1** is a connection position of the sec-

ond conductive element **303-2** and the power supply line **L2** at the upper left portion of the heating block **302-2**. Thus, the connection positions **CP1** and **CP2** are set at opposed positions in the longitudinal direction of the substrate. In other words, the connection positions of the first conductive element **301-2** and the second conductive element **303-2** of the heating block **302-2** with the power supply lines that extend from the electrode **E2** and the electrode **E4** are arranged at opposed positions in the longitudinal direction of the substrate.

According to the present embodiment, as illustrated in FIG. 3A, power is supplied to all of the three heating blocks by the diagonal power feeding. However, even if power is supplied to at least one heating block out of the three heating blocks by the diagonal power feeding, uneven heat distribution can be reduced.

If power is supplied without using the diagonal power feeding from the lower right portion of the conductive element **301-2** of the heating block **302-2** and from the upper right portion of the conductive element **303-2** of the heating block **302-2** (see FIG. 3A), voltage drop occurs on the left side of the heating block **302-2** owing to the effect of the resistance value of the conductive element. Thus, the amount of heat generation on the left side of the heating block **302-2** will be reduced.

Further, according to the present embodiment, the positions of the plurality of heat generating resistors which are parallelly connected are slanted with respect to the longitudinal direction and the widthwise direction of the substrate such that adjacent heat generating resistors overlap with each other in the longitudinal direction. In this manner, the effect of the gap portions between the plurality of heat generating resistors is reduced and uniformity regarding the heat distribution in the longitudinal direction of the heater **300** can be improved. Further, according to the heater **300** of the present embodiment, regarding the gap portions of the plurality of heating blocks, since the heat generating resistors at the end portions of the adjacent heating blocks overlap in the longitudinal direction, uniformity regarding the heat distribution can be furthermore improved.

As described above, the thermistors **TH1** to **TH4**, which are temperature detecting elements, and the safety element **212** contact the back side of the heater **300**. The power control of the heater **300** is based on the output of the thermistor **TH1** provided near the center of the sheet-passing portion (near a conveyance reference position **X** described below). The thermistor **TH4** detects the temperature at the end portion of the heat generating area of the heating block **302-2** (the state in FIG. 3B). Further, the thermistor **TH2** detects the temperature at the end portion of the heat generating area of the heating block **302-1** (the state in FIG. 3A) and the thermistor **TH3** detects the temperature at the end portion of the heat generating area of the heating block **302-3** (the state in FIG. 3A).

According to the laser printer **100** of the present embodiment, one or more thermistors are provided on each of the three heating blocks so that if power is supplied only to a single heating block due to, for example, device failure, such a state can be detected. Thus, the safety of the apparatus can be enhanced.

The safety element **212** is arranged in such a manner that it can operate in different states. Namely, the safety element **212** can operate in a state where power is supplied only to the heating block **302-2** at the center portion of the heater **300** as illustrated in FIG. 3B. Further, the safety element **212** can operate in a state where power is supplied only to the heating blocks **302-1** and **302-3** on the ends of the heater **300** due to, for example, device failure. In other words, the safety element



**212** is provided at a position between the heating block **302-2** at the center portion and either of the heating blocks **302-1** and **302-3**. The safety element **212** is turned on when abnormal heating of the heater **300** occurs so that power supplied to the heater **300** is stopped.

Next, temperature rise at the non-sheet-passing portion when power is supplied to all the three heating blocks **302-1**, **302-2**, and **302-3** will be described with reference to FIG. **3A**. The center of the heat generating area is set as a reference position and B5 paper is fed by short edge feeding. The reference position when paper is conveyed is defined as the conveyance reference position X of a recording material (paper).

The sheet cassette **11** includes a position regulating plate which regulates the position of the paper. The recording material P is fed from a predetermined position of the sheet cassette **11** according to the size of the recording material P which is loaded and conveyed to pass a predetermined portion of the image heating device **200**. Similarly, the paper feeding tray **28** includes a position regulating plate which regulates the position of the paper. The recording material P is fed from the paper feeding tray **28** and conveyed to pass a predetermined portion of the image heating device **200**.

The heater **300** has a heat generating area of a length of 220 mm which enables short edge feeding of Letter paper with a width of approximately 216 mm. If B5 paper with a paper width of 182 mm is fed to the heater **300** having a heat generating area of a length of 220 mm, a non-sheet-passing area of 19 mm is generated at both ends of the heat generating area. Although the power supplied to the heater **300** is controlled so that the temperature detected by the thermistor TH1 provided near the center of the sheet-passing portion is continuously the target temperature, since the heat generated at the non-sheet-passing portion is not removed by paper, the temperature of the non-sheet-passing portion is increased compared to the sheet-passing portion.

As illustrated in FIG. **3A**, in printing B5-size paper, the sides of the recording material passes a part of the heating blocks **302-1** and **302-3** at both ends of the heater **300**. Thus, a non-sheet-passing portion of 19 mm is generated at both ends of the heating blocks **302-1** and **302-3**. However, since the heat generating resistor is a PTC material, the resistance of the heat generating resistor at the non-sheet-passing portion will be higher than the resistance of the heat generating resistor at the sheet-passing portion, so that the current flows less easily. According to this principle, the temperature rise at the non-sheet-passing portion can be reduced.

The temperature rise at the non-sheet-passing portion when power is supplied only to the heating block **302-2** at the center portion of the heater **300** will be described with reference to FIG. **3B**. In FIG. **3B**, the center of the heat generating area is set as the reference position and a DL-size envelope with a width of 110 mm is fed by short edge feeding. The length of the heat generating area of the heating block **302-2** of the heater **300** is 157 mm which enables short edge feeding of A5 paper which has a width of approximately 148 mm. If a DL size envelope, which has a width of 110 mm, is fed to the heater **300** provided with the heating block **302-2**, which has a length of 157 mm, by short edge feeding, a non-sheet-passing area of 23.5 mm is generated at each end of the heating block **302-2** at the center portion. The heater **300** is controlled based on the output of the thermistor TH1 provided at about the center of the sheet-passing portion. Since, the heat generated at the non-sheet-passing portion is not removed by paper, the temperature of the non-sheet-passing portion is increased compared to the sheet-passing portion.

In the state illustrated in FIG. **3B**, by supplying power only to the heating block **302-2**, the length of the non-sheet-passing area can be reduced. Generally, the longer the non-sheet-passing portion area is, the more the temperature increases at the non-sheet-passing portion. Thus, the temperature rise at the non-sheet-passing portion may not be satisfactorily controlled if the control is performed depending only on the effect of power feeding to the heat generating resistor, which is a PTC material, in the paper conveying direction. Thus, as illustrated in FIG. **3B**, the length of the non-sheet-passing area is reduced. Further, the temperature rise in the non-sheet-passing area of 23.5 mm at each end of the heating block **302-2** can be reduced by a principle same as the one described with reference to FIG. **3A**.

FIG. **4** is a heater control circuit diagram according to the first exemplary embodiment. An AC power supply **401** is a commercial power supply connected to the laser printer **100**. The power supplied to the heater **300** is controlled by power on/off of a triac **416** and a triac **426**. The power to the heater **300** is supplied via the electrodes E1 to E4. According to the present embodiment, the resistance values of the heating blocks **302-1**, **302-2**, and **302-3** are 70 ohms, 14 ohms, and 70 ohms, respectively.

A zero cross detection unit **430** detects zero-crossing of the AC power supply **401** and outputs a zero-cross signal to a central processing unit (CPU) **420**. The zero-cross signal is used for controlling the heater **300**. For example, if the temperature of the heater **300** excessively increases due to some failure, a relay **440** operates according to a signal output from the thermistors TH1 to TH4 and stops the power to the heater **300**.

Next, the operation of the triac **416** will be described. Resistors **413** and **417** are bias resistors for the triac **416**. A phototriac coupler **415** is provided so that creepage distance is maintained between primary and secondary circuits. The triac **416** is turned on when a light emitting diode of the phototriac coupler **415** is energized. A resistor **418** limits the electric current of the light emitting diode of the phototriac coupler **415**. The phototriac coupler **415** is turned on/off by a transistor **419**. The transistor **419** operates according to a signal (FUSER1) output from the CPU **420**.

When the triac **416** is energized, power is supplied to the heating block **302-2** of the resistance value of 14 ohms. When the power is controlled so that the energizing ratio of the triac **416** and the triac **426** is 1:0, power is supplied only to the heating block **302-2**. FIG. **3B** illustrates the heater **300** in this state.

Since the circuit operation of the triac **426** is similar to the operation of the triac **416**, it is not described. The triac **426** operates according to a signal (FUSER2) output from the CPU **420**. When the triac **426** is energized, power is supplied to the heating block **302-1** (70 ohms) and the heating block **302-3** (70 ohms). Since these two heating blocks are parallelly-connected, power is supplied to a resistance of 35 ohms.

In the state illustrated in FIG. **3A**, power is supplied via the triacs **416** and **426**. In other words, when the triacs **416** and **426** are energized, power is supplied to the heating block **302-1** (70 ohms), the heating block **302-2** (14 ohms), and the heating block **302-3** (70 ohms). Since these three heating blocks are parallelly-connected, power is supplied to a resistance of 10 ohms. When the power is controlled so that the energizing ratio of the triac **416** and the triac **426** is 1:1, the heater **300** will be in the state described with reference to FIG. **3A**.

The total resistance of the heater **300** is set to such a value that the power necessary for fixing a recording material with a largest paper width which can be printed by the laser printer



100 (Letter paper or Legal paper according to the present embodiment) is ensured. In other words, when power is supplied to all of the three heating blocks 302-1 to 302-3 as illustrated in FIG. 3A, the total resistance value will be 10 ohms.

According to the present embodiment, since the heating blocks 302-1 and 302-3 at both ends of the heater 300 and the heating block 302-2 at the center are parallelly-connected, the total resistance value is 14 ohms in a state where power is supplied only to the center of the heating block 302-2 as illustrated in FIG. 3B. This is higher than the total resistance value of 10 ohms in a state where power is supplied to all of the three heating blocks as illustrated in FIG. 3A. Thus, compared to the state illustrated in FIG. 3A, the heater 300 in the state illustrated in FIG. 3B is furthermore advantageous with respect to harmonic, flicker, and heater protection (generally, the lower resistance value, the adversely these items are affected). In contrast, if the three heating blocks 302-1 to 302-3 are series-connected and power is supplied only to the heating block 302-2 at the center portion of the heater 300, since the total resistance value of the heater is reduced, it is disadvantageous with respect to, for example, harmonic. Accordingly, designing the heater will become difficult.

The temperature detected by the thermistor TH1 is detected by the CPU 420 as a signal of the TH1 with voltage divided using resistors (not illustrated). The temperatures of the thermistors TH2 to TH4 are detected by the CPU 420 by a similar method. Based on the temperature detected by the thermistor TH1 and the temperature set to the heater 300, the CPU 420 (control unit) calculates the power to be supplied through internal processing such as proportional integral (PI) control. Further, the CPU 420 converts it to a control level of a phase angle (phase control) or a wave number (wave number control) which corresponds to the power to be supplied. Then, the CPU 420 controls the triac 416 and the triac 426 according to the control level.

FIG. 5 is a flowchart illustrating a control sequence of the image heating device 200 performed by the CPU 420. In step S502, the CPU 420 receives a print request. In step S503, the CPU 420 determines whether the width of the paper to be printed is 157 mm or more. According to the laser printer 100 of the present embodiment, the CPU 420 determines whether the paper is Letter paper, Legal paper, A4 paper, Executive paper, B5 paper, or non-standard paper with a width of 157 mm or more and fed from the paper feeding tray 28. If the CPU 420 determines that the paper is such paper (YES in step S503), the processing proceeds to step S504. In step S504, the CPU 420 sets the energizing ratio of the triac 416 to the triac 426 to 1:1 (the state in FIG. 3A).

If the paper width is less than 157 mm (according to the present embodiment, A5 paper, DL envelope, Com10 envelope, or non-standard paper with a width less than 157 mm) (NO in step S503), the processing proceeds to step S505. In step S505, the CPU 420 sets the energizing ratio of the triac 416 to the triac 426 to 1:0 (the state in FIG. 3B).

In step S506, by using the energizing ratio which has been set, the CPU 420 performs the fixing processing while setting the image forming process speed to full speed (1/1 speed) and controlling the heater 300 so that the temperature detected by the thermistor TH1 is continuously the target preset temperature (200° C.).

In step S507, the CPU 420 determines whether the temperature of the thermistor TH2 has exceeded a maximum temperature TH2Max of the thermistor TH2, the temperature of the thermistor TH3 has exceeded a maximum temperature TH3Max of the thermistor TH3, and the temperature of the thermistor TH4 has exceeded a maximum temperature

TH4Max of the thermistor TH4. The maximum temperatures are set to the CPU 420 in advance. If the CPU 420 determines that any of the temperatures at the end portions of the heat generating area has exceeded the predetermined upper limit (the maximum temperatures TH2Max, TH3Max, or TH4Max) due to the increase in the temperature of the non-sheet-passing portion based on the signals of the thermistors TH2 to TH4 (NO in step S507), the processing proceeds to step S509. In step S509, the CPU 420 performs the fixing processing while setting the image forming process speed to half speed (1/2 speed) and controlling the heater 300 so that the temperature detected by the thermistor TH1 is continuously the target preset temperature (170° C.). If the image forming process speed is reduced to half, since good fixing can be obtained even at a low temperature, the fixing target temperature can be reduced and the increase in temperature at the non-sheet-passing portion can be reduced.

In step S508, the CPU 420 determines whether the end of the print job has been detected. If the end of the print job has been detected (YES in step S508), the control sequence of the image forming ends. If the end of the print job has not yet been detected (NO in step S508), the processing returns to step S506. In step S510, the CPU 420 determines whether the end of the print job has been detected. If the end of the print job has been detected (YES in step S510), the control sequence of the image forming ends. If the end of the print job has not yet been detected (NO in step S510), the processing returns to step S509.

As described above, by using the heater 300 and the image heating device 200 according to the first exemplary embodiment, temperature rise can be reduced at the non-sheet-passing portion in a case where paper of a size smaller than the largest printable paper of the laser printer 100 is printed. Further, occurrence of uneven temperature at the gap portion of the plurality of heating blocks and uneven temperature of each of the heating blocks in the longitudinal direction of the heater 300 can be prevented. Further, safety of the image heating device 200 in the event of a failure can be enhanced.

Next, a second exemplary embodiment of the present invention will be described. The heater of the image heating device of the laser printer 100 is different from the heater according to the first exemplary embodiment. Descriptions of components similar to those of the first exemplary embodiment are not repeated. Unlike the first exemplary embodiment, the heating block of the heater according to the second exemplary embodiment includes one heat generating resistor.

An image heating device 600 illustrated in FIG. 6 includes a heater 700. The heat generating surface of the heater 700 is provided on the side opposite the surface of the heater that contacts the fixing film. The heater 700 includes a heater substrate 705 which is ceramic, a first conductive element 701, a second conductive element 703, and a heat generating resistor 702. The first conductive element 701 is provided on the heater substrate 705 along the longitudinal direction of the substrate. The second conductive element 703 is also provided on the heater substrate 705 along the longitudinal direction of the substrate but at a position different from the first conductive element 701 in the widthwise direction of the substrate. The heat generating resistor 702 is provided between the first conductive element 701 and the second conductive element 703 and has a positive temperature characteristic of resistance. Further, the heater 700 includes a surface protection layer 707 and a slide layer 706. The surface protection layer 707 covers the heat generating resistor 702, the first conductive element 701, and the second conductive element 703, and has an insulation property. According to the present embodiment, glass is used for the surface protection



layer 707. The slide layer 706 contributes to realizing smoother sliding on the sliding surface of the heater 700.

FIG. 7A illustrates a configuration of the heater 700 according to the second exemplary embodiment. According to the second exemplary embodiment, the heater 700 includes three divided heating blocks 702-1, 702-2, and 702-3. Each of these heating blocks includes one heat generating resistor. Since other components and configuration of the present embodiment are similar to those of the first exemplary embodiment, the points different from the first exemplary embodiment are described.

The thermistors TH1 to TH4 and the safety element 212 contact the back side of the heater 700 as described above. According to the second exemplary embodiment, the safety element 212 contacts a sheet-passing area on the heater 700. The sheet-passing area is where a sheet of the smallest size which can be printed by the laser printer 100 passes. The portion where the safety element 212 contacts is a portion which is less affected by the temperature rise at the non-sheet-passing portion.

Next, temperature rise at the non-sheet-passing portion when power is supplied to all the three heating blocks 702-1, 702-2, and 702-3 will be described with reference to FIG. 7A. The center of the heat generating area is set as a reference position and A4 paper is fed by short edge feeding. The heater 700 has a heat generating area of a length of 220 mm which enables short edge feeding of Letter paper with a width of approximately 216 mm. If A4 paper with a paper width of 210 mm is fed to the heater 300 having a heat generating area of a length of 220 mm, a non-sheet-passing area of 5 mm is generated at both ends of the heat generating area. Although the power supplied to the heater 700 is controlled so that the temperature detected by the thermistor TH1 provided near the center of the sheet-passing portion is continuously the target temperature, since the heat generated at the non-sheet-passing portion is not removed by paper, the temperature of the non-sheet-passing portion is increased compared to the sheet-passing portion.

As illustrated in FIG. 7A, in printing A4-size paper, the sides of the recording material passes a part of the heating blocks 702-1 and 702-3, respectively at both ends of the heater 700. Thus, a non-sheet-passing portion of 5 mm is generated at both ends of the heating blocks 702-1 and 702-3. However, since the heat generating resistor is a PTC material, the electric resistance of the heat generating resistor at the non-sheet-passing portion is higher than the electric resistance of the heat generating resistor at the sheet-passing portion. Thus, the current flows less easily and the temperature rise at the non-sheet-passing portion can be reduced by the principle described with reference to FIG. 3A according to the first exemplary embodiment.

FIG. 7B illustrates the temperature rise at the non-sheet-passing portion when power is supplied only to the heating block 702-2 at the center portion of the heater 700. In FIG. 7B, the center of the heat generating area is set as the reference position and A5-size paper is fed by short edge feeding. The length of the heat generating area of the heating block 702-2 of the heater 700 is 185 mm which enables short edge feeding of Executive paper with a width of approximately 184 mm. If A5-size paper with a paper width of 148 mm is fed by short edge feeding to the heater 700 with the heat generating area of a length of 185 mm, a non-sheet-passing area of 18.5 mm is generated at each end of the heat generating area. The temperature rise in this non-sheet-passing area can be reduced by a principle same as the one described with reference to FIG. 3B according to the first exemplary embodiment.

FIG. 8 is a heater control circuit diagram according to the second exemplary embodiment. The power supplied to the heater 700 is controlled by power on/off of a triac 816. In FIG. 4 according to the first exemplary embodiment, although two triacs are used in controlling the power supply to the heater, one triac (triac 816) and a relay 800 are used according to the second exemplary embodiment. The relay 800 operates according to an RLON800 signal output by a CPU 820.

If the triac 816 is energized when the relay 800 is turned off, power is supplied to the heating block 702-2. FIG. 7B illustrates the heater 700 in this state. If the triac 816 is energized when the relay 800 is turned on, power is supplied to the heating blocks 702-1, 702-2, and 702-3. FIG. 7A illustrates the heater 700 in this state.

According to the configuration described in the second exemplary embodiment, a case where power is supplied only to the heating blocks 702-1 and 702-3 at both ends of the heater 700 can be prevented regardless of the operating state of the relay 800 when, for example, a short-circuit failure or an open-circuit failure occurs. If power is supplied to the heating blocks 702-1 and 702-3 at both ends of the heater 700, power is also supplied to the heating block 702-2 at the center portion of the heater 700 regardless of the operating state of the relay 800. Thus, according to the present embodiment, the safety element 212 is provided to contact the sheet-passing area of the paper of the smallest size printable by the laser printer 100 which is less affected by the temperature rise at the non-sheet-passing portion. According to this arrangement, since the temperature of the safety element 212 is decreased in normal operation, the operation temperature of the safety element 212 can be set to a lower temperature. Accordingly, safety of the image heating device 600 can be enhanced.

FIG. 9 is a flowchart illustrating a control sequence of the image heating device 600 performed by the CPU 820. In step S902, the CPU 820 receives a print request. In step S903, the CPU 820 determines whether the width of the paper to be printed is 185 mm or more. According to the laser printer 100 of the present embodiment, the CPU 820 determines whether the paper is Letter paper, Legal paper, A4 paper, or non-standard paper with a width of 185 mm or more which is fed from the paper feeding tray 28. If the CPU 820 determines that the paper is such paper (YES in step S903), the processing proceeds to step S904. In step S904, the CPU 820 maintains the turn-on state of the relay 800 (state in FIG. 7A).

If the paper width is less than 185 mm (according to the present embodiment, Executive paper, B5 paper, A5 paper, DL envelope, Com10 envelope, or non-standard paper having a width less than 185 mm) (NO in step S903), the processing proceeds to step S905. In step S905, the CPU 820 maintains the turn-off state of the relay 800 (state in FIG. 7B).

In step S906, while maintaining the state of the relay 800 which has been set, the CPU 820 performs the image forming processing while setting the image forming process speed to full speed and controlling the heater 700 so that the temperature detected by the thermistor TH1 is continuously the target preset temperature (200° C.).

In step S907, the CPU 820 determines whether the temperature of the thermistor TH2 has exceeded the maximum temperature TH2Max of the thermistor TH2, the temperature of the thermistor TH3 has exceeded the maximum temperature TH3Max of the thermistor TH3, and the temperature of the thermistor TH4 has exceeded the maximum temperature TH4Max of the thermistor TH4. The maximum temperatures are set to the CPU 820 in advance. If the CPU 820 determines that any of the temperatures at the end portions of the heat generating area has exceeded the predetermined upper limit



(the maximum temperatures TH2Max, TH3Max, or TH4Max) due to the increase in temperature of the non-sheet-passing portion, based on the signals of the thermistors TH2 to TH4 (NO in step S907), the processing proceeds to step S909. In step S909, the CPU 820 performs the image forming processing while setting the image forming process speed to half speed and controlling the heater so that the temperature detected by the thermistor TH1 is continuously the preset target temperature (170° C.).

In step S908, the CPU 420 determines whether the end of the print job has been detected. If the end of the print job has been detected (YES in step S908), the control sequence of the image forming ends. If the end of the print job has not yet been detected (NO in step S908), the processing returns to step S906. In step S910, the CPU 420 determines whether the end of the print job has been detected. If the end of the print job has been detected (YES in step S910), the control sequence of the image forming ends. If the end of the print job has not yet been detected (NO in step S910), the processing returns to step S909.

Next, a third exemplary embodiment of the present invention will be described. FIGS. 10A to 10C illustrate alternate versions of the heater. A heater 110 illustrated in FIG. 10A has a characteristic in that a heating block 112-2 at the center includes 15 heat generating resistors 112-2-1 to 112-2-15. In order to reduce the effect of voltage drop caused by the conductive element, the resistance values in the widthwise direction of the heat generating resistors, which are connected in parallel, are differentiated. In other words, the resistance value of each of the heat generating resistors 112-2-1 and 112-2-15 provided at the end in the longitudinal direction is higher than the resistance value of the heat generating resistor 112-2-8 provided at the center. Alternatively, the heat generating resistors may be arranged so that the element-to-element pitch of the heat generating resistors becomes greater toward each end of the heating block in the longitudinal direction. Further, both the resistance value and the pitch of the heat generating resistors can be adjusted to each other.

Further, regarding a heating block 112-1 at one end of the heater 110, the resistance value of each of heat generating resistors 112-1-1 and 112-1-3 provided at the end portions of the heating block is set to a higher value compared to the resistance value of a heat generating resistor 112-1-2 provided at the center portion of the heating block.

Similarly, regarding a heating block 112-3 at the other end of the heater 110, the resistance value of each of heat generating resistors 112-3-1 and 112-3-3 provided at the end portions of the heating block is set to a higher value compared to the resistance value of a heat generating resistor 112-3-2 provided at the center portion of the heating block. By using the heater 110 according to the present embodiment, heat can be more uniformly distributed in the longitudinal direction of the heater of the heating block. Regarding the heating blocks 112-1 and 112-3 at the end portions, the pitch of the heat generating resistors can be adjusted to each other just as the heat generating resistors of the heating block 112-2 at the center portion.

A heater 120 illustrated in FIG. 10B has a characteristic in that power is fed to a heating block 122-2 at the center portion of the heater 120 from a portion near the center of the heating blocks of each of a first conductive element 121-2 and a second conductive element 123-2. This power supplying method is hereinafter referred to as central power feeding. Thus, the effect of reducing the temperature rise at the non-sheet-passing portion can be enhanced as described with reference to FIG. 3B. In other words, the connection positions of the heating block 122-2 and the power supply lines which

extend from the electrodes are arranged at the center of the first conductive element 121-2 and the center of the second conductive element 123-2 in the longitudinal direction.

The heating block 122-2 at the center portion of the heater 120 will be described. The heating block 122-2 is arranged between the first conductive element 121-2 and the second conductive element 123-2 and includes 15 heat generating resistors 122-2-1 to 122-2-15 arranged at regular intervals. The heat generating resistors 122-2-1 to 122-2-15 of the heating block 122-2, the conductive element 121-2, and the conductive element 123-2 are made of a PTC material.

If a temperature rise at each of the non-sheet-passing portions occurs when the heater 120 is in the state illustrated in FIG. 3B, the temperatures at the non-sheet-passing portions of the conductive element 121-2 and the conductive element 123-2 are increased as the temperature of the heat generating resistor at the non-sheet-passing portion of the heating block 122-2 is increased. If the temperatures of the conductive elements at the non-sheet-passing portions are increased, since the conductive elements have PTC characteristics, the resistance value of each of the conductive elements at the non-sheet-passing portions is increased. Accordingly, the electric current flows less easily. If the electric current that flows through each of the conductive elements at the non-sheet-passing portions is reduced, the current that flows through the heat generating resistor at the non-sheet-passing portion will also be reduced. Accordingly, the effect of reducing the temperature rise at each of the non-sheet-passing portions can be enhanced compared to a case where the temperature rise is controlled depending only on the effect of the PTC of the heat generating resistor.

Further, in order to correct the effect of the voltage drop due to the conductive element, regarding the resistance values in the widthwise direction of the heat generating resistors, which are connected in parallel, of the heating block at the center, the resistance value of each of the heat generating resistors 122-2-1 and 122-2-15 arranged at the end portion in the longitudinal direction is set to a value lower than the resistance value of the heat generating resistor 122-2-8 arranged at the center in the longitudinal direction. Alternatively, the parallelly-connected heat generating resistors of the heating block at the center portion are arranged so that the element-to-element pitch of the heat generating resistors becomes smaller toward each end of the heating block in the longitudinal direction. Since heating blocks 122-1 and 122-3 are similar to the heating blocks 112-1 and 112-3 of the heater 110 described above, their descriptions are not repeated.

A heater 130 illustrated in FIG. 10C performs the central power feeding to a heating block 132-2 at the center portion of the heater 130 similar to the heater 120. Accordingly, the effect of reducing the temperature rise at the non-sheet-passing portions when the heater 130 is in the state illustrated in FIG. 7B can be enhanced. Since heating blocks 132-1 and heating block 132-3 are similar to the heating blocks 702-1 and 702-3 of the heater 700 described above, their descriptions are not repeated.

While the present invention has been described with reference to exemplary embodiments, it is to be understood that the invention is not limited to the disclosed exemplary embodiments. The scope of the following claims is to be accorded the broadest interpretation so as to encompass all such modifications and equivalent structures and functions.

This application claims the benefit of Japanese Patent Application No. 2012-205713 filed Sep. 19, 2012, which is hereby incorporated by reference herein in its entirety.



What is claimed is:

1. A heater used for an image heating device that heats an image formed on a recording sheet, the heater comprising:
  - a substrate having dimensions in a lengthwise direction and a widthwise direction;
  - a first conductive element provided on the substrate along the lengthwise direction of the substrate;
  - a second conductive element provided on the substrate along the lengthwise direction at a position different from the first conductive element in the widthwise direction of the substrate;
  - a heat generating resistor provided between the first conductive element and the second conductive element and showing a positive temperature characteristic of resistance, which generates heat when power is supplied via the first conductive element and the second conductive element; and
  - electrodes to which connectors for power supply are connected,
 wherein first and second heating blocks each of which includes a set of the first conductive element, the second conductive element, and the heat generating resistor, are arranged in the lengthwise direction,
 wherein the first heating block is arranged at a center of the heater in the lengthwise direction, and the second heating block is arranged at a position farther from the center of the heater,
 wherein power control of the first and second heating blocks can be performed independent of each other,
 wherein a plurality of heat generating resistors are electrically connected between the first conductive element and the second conductive element of at least one of the first and second heating blocks in a parallel manner, and
 wherein resistance values of heat generating resistors provided closer to connection positions of the first conductive element and the second conductive element with power supply lines which extend from the electrodes are higher than a resistance value of a heat generating resistor provided away from the connection positions.
2. The heater according to claim 1, wherein the first and second heating blocks are in parallel connected to a power source.
3. The heater according to claim 1, wherein the connection positions of the first conductive element and the second conductive element of at least one of the first and second heating blocks, with the power supply lines which extend from the electrodes, are on opposite sides in the lengthwise direction.
4. The heater according to claim 3, wherein the connection positions are on opposite sides in the lengthwise direction in both the first and second heating blocks.
5. The heater according to claim 3, wherein a heating block having the opposite connection positions is the second heating block, and the connection positions of the first heating block are at a center of the first conductive element and a center of the second conductive element in the lengthwise direction.
6. The heater according to claim 1, wherein the plurality of heat generating resistors connected in a parallel manner are arranged in a slanted manner with respect to the lengthwise direction and the widthwise direction of the heater, wherein each heat generating resistor overlaps with each other in the lengthwise direction.
7. The heater according to claim 1, wherein intervals of the heat generating resistors provided closer to connection positions of the first conductive element and the second conduc-

tive element with the power supply lines which extend from the electrodes are wider than an interval of heat generating resistors provided away from the connection positions.

8. The image heating device according to claim 1, wherein intervals of the heat generating resistors provided closer to connection positions of the first conductive element and the second conductive element with the power supply lines which extend from the electrodes are wider than an interval of heat generating resistors provided away from the connection positions.
9. An image heating device for heating an image formed on a recording sheet, comprising:
  - a heater; and
  - a controller configured to control power supplied to the heater,
 wherein the heater includes;
  - a substrate having dimensions in a lengthwise direction and a widthwise direction;
  - a first conductive element provided on the substrate along the lengthwise direction of the substrate;
  - a second conductive element provided on the substrate along the lengthwise direction at a position different from the first conductive element in the widthwise direction of the substrate;
  - a heat generating resistor provided between the first conductive element and the second conductive element and showing a positive temperature characteristic of resistance, which generates heat when power is supplied via the first conductive element and the second conductive element; and
  - electrodes to which connectors for power supply are connected,
 wherein first and second heating blocks each of which includes a set of the first conductive element, the second conductive element, and the heat generating resistor, are arranged in the lengthwise direction,
 wherein the first heating block is arranged at a center of the heater in the lengthwise direction, and the second heating block is arranged at a position farther from the center of the heater,
 wherein power control of the first and second heating blocks can be performed independent of each other by the controller,
 wherein a plurality of heat generating resistors are electrically connected between the first conductive element and the second conductive element of at least one of the first and second heating blocks in a parallel manner, and
 wherein resistance values of heat generating resistors provided closer to connection positions of the first conductive element and the second conductive element with power supply lines which extend from the electrodes are higher than a resistance value of a heat generating resistor provided away from the connection positions.
10. The image heating device according to claim 9, wherein the connection positions of the first conductive element and the second conductive element of at least one of the first and second heating blocks, with the power supply lines which extend from the electrodes, are on opposite sides in the lengthwise direction.
11. The image heating device according to claim 10, wherein the connection positions are on opposite sides in the lengthwise direction in both the first and second heating blocks.
12. The image heating device according to claim 10, wherein a heating block having the opposite connection positions is the second heating block, and the connection positions of the first heating block are at a center of the first



17

conductive element and a center of the second conductive element in the lengthwise direction.

13. The image heating device according to claim 9, wherein the plurality of heat generating resistors connected in a parallel manner are arranged in a slanted manner with respect to the lengthwise direction and the widthwise direction of the heater, wherein each heat generating resistor overlaps with each other in the lengthwise direction.

14. The image heating device according to claim 9, wherein the heater includes a total of three heating blocks, the first heating block is arranged at a center portion and the second heating blocks are arranged at both end portions of the heater in the lengthwise direction, and wherein a safety element which operates when abnormal heating of the heater occurs and stops power to be supplied to the heater is provided at a position between the first heating block at the center portion and one of the second heating blocks at either of end portions.

15. The image heating device according to claim 9, further comprising first and second temperature detecting elements corresponding to the first and second heating blocks, respectively, wherein power to be supplied to the first and second heating blocks are controlled according to a detected temperature of the first and second temperature detecting elements.

16. The image heating device according to claim 9, further comprising an endless belt with its inner surface in contact with the heater, and a nip portion forming member configured to form a nip portion which conveys the recording sheet, together with the heater through the endless belt.

17. A heater used for an image heating device that heats an image formed on a recording sheet, the heater comprising:

a substrate having dimensions in a lengthwise direction and a widthwise direction;

a first conductive element provided on the substrate along the lengthwise direction of the substrate;

a second conductive element provided on the substrate along the lengthwise direction at a position different from the first conductive element in the widthwise direction of the substrate;

a heat generating resistor provided between the first conductive element and the second conductive element and showing a positive temperature characteristic of resistance, which generates heat when power is supplied via the first conductive element and the second conductive element, and

electrodes to which connectors for power supply are connected,

wherein first and second heating blocks each of which includes a set of the first conductive element, the second conductive element, and the heat generating resistor, are arranged in the lengthwise direction,

wherein the first heating block is arranged at a center of the heater in the lengthwise direction, and the second heating block is arranged at a position farther from the center of the heater,

wherein power control of the first and second heating blocks can be performed independent of each other,

wherein a plurality of heat generating resistors are electrically connected between the first conductive element and the second conductive element of at least one of the first and second heating blocks in a parallel manner, and

wherein intervals of heat generating resistors provided closer to connection positions of the first conductive element and the second conductive element with power supply lines which extend from the electrodes

18

are wider than an interval of heat generating resistors provided away from the connection positions.

18. The heater according to claim 17, wherein the first and second heating blocks are in parallel connected to a power source.

19. The heater according to claim 17, wherein the connection positions of the first conductive element and the second conductive element of at least one of the first and second heating blocks, with the power supply lines which extend from the electrodes, are on opposite sides in the lengthwise direction.

20. The heater according to claim 19, wherein the connection positions are on opposite sides in the lengthwise direction in both the first and second heating blocks.

21. The heater according to claim 16, wherein a heating block having the opposite connection positions is the second heating block, and the connection positions of the first heating block are at a center of the first conductive element and a center of the second conductive element in the lengthwise direction.

22. An image heating device for heating an image formed on a recording sheet, comprising:

a heater; and

a controller configured to control power supplied to the heater,

wherein the heater includes;

a substrate having dimensions in a lengthwise direction and a widthwise direction;

a first conductive element provided on the substrate along the lengthwise direction of the substrate;

a second conductive element provided on the substrate along the lengthwise direction at a position different from the first conductive element in the widthwise direction of the substrate;

a heat generating resistor provided between the first conductive element and the second conductive element and showing a positive temperature characteristic of resistance, which generates heat when power is supplied via the first conductive element and the second conductive element, and

electrodes to which connectors for power supply are connected,

wherein first and second heating blocks each of which includes a set of the first conductive element, the second conductive element, and the heat generating resistor, are arranged in the lengthwise direction,

wherein the first heating block is arranged at a center of the heater in the lengthwise direction, and the second heating block is arranged at a position farther from the center of the heater,

wherein power control of the first and second heating blocks can be performed independent of each other by the controller,

wherein a plurality of heat generating resistors are electrically connected between the first conductive element and the second conductive element of at least one of the first and second heating blocks in a parallel manner, and

wherein intervals of heat generating resistors provided closer to connection positions of the first conductive element and the second conductive element with power supply lines which extend from the electrodes are wider than an interval of heat generating resistors provided away from the connection positions.

23. The image heating device according to claim 22, wherein the connection positions of the first conductive element and the second conductive element of at least one of the



19

first and second heating blocks, with the power supply lines which extend from the electrodes, are on opposite sides in the lengthwise direction.

24. The image heating device according to claim 23, wherein the connection positions are on opposite sides in the lengthwise direction in both the first and second heating blocks.

25. The image heating device according to claim 23, wherein a heating block having the opposite connection positions is the second heating block, and the connection positions of the first heating block are at a center of the first conductive element and a center of the second conductive element in the lengthwise direction.

26. The image heating device according to claim 22, further comprising an endless belt with its inner surface in contact with the heater, and a nip portion forming member configured to form a nip portion which conveys the recording sheet, together with the heater through the endless belt.

27. A heater used for an image heating device that heats an image formed on a recording sheet, the heater comprising:

a substrate having dimensions in a lengthwise direction and a widthwise direction;

a first conductive element provided on the substrate along the lengthwise direction of the substrate;

a second conductive element provided on the substrate along the lengthwise direction at a position different from the first conductive element in the widthwise direction of the substrate; and

a heat generating resistor provided between the first conductive element and the second conductive element, which generates heat when power is supplied via the first conductive element and the second conductive element, wherein first and second heating blocks each of which includes a set of the first conductive element, the second conductive element, and the heat generating resistor, are arranged in the lengthwise direction,

wherein the first heating block is arranged at a center of the heater in the lengthwise direction, and the second heating block is arranged at a position farther from the center of the heater,

wherein each of the first and second heating blocks includes only one heat generating resistor, and

wherein power control of the first and second heating blocks can be performed independent of each other.

28. The heater according to claim 27, wherein the first and second heating blocks are in parallel connected to a power source.

29. The heater according to claim 27, further comprising electrodes to which connectors for power supply are connected, wherein connection positions of the first conductive element and the second conductive element of at least one of the first and second heating blocks, with power supply lines which extend from the electrodes, are on opposite sides in the lengthwise direction.

30. The heater according to claim 29, wherein the connection positions are on opposite sides in the lengthwise direction in both the first and second heating blocks.

31. The heater according to claim 29, wherein a heating block having the opposite connection positions is the second heating block, and the connection positions of the first heating

20

block are at a center of the first conductive element and a center of the second conductive element in the lengthwise direction.

32. An image heating device for heating an image formed on a recording sheet, comprising:

a heater;

a controller configured to control power supplied to the heater,

wherein the heater includes;

a substrate having dimensions in a lengthwise direction and a widthwise direction;

a first conductive element provided on the substrate along the lengthwise direction of the substrate;

a second conductive element provided on the substrate along the lengthwise direction at a position different from the first conductive element in the widthwise direction of the substrate; and

a heat generating resistor provided between the first conductive element and the second conductive element, which generates heat when power is supplied via the first conductive element and the second conductive element, wherein first and second heating blocks each of which includes a set of the first conductive element, the second conductive element, and the heat generating resistor, are arranged in the lengthwise direction,

wherein the first heating block is arranged at a center of the heater in the lengthwise direction, and the second heating block is arranged at a position farther from the center of the heater,

wherein each of the first and second heating blocks includes only one heat generating resistor, and

wherein power control of the first and second heating blocks can be performed independent of each other by the controller.

33. The image heating device according to claim 32, wherein the heater includes electrodes to which connectors for power supply are connected, and wherein connection positions of the first conductive element and the second conductive element of at least one of the first and second heating blocks, with the power supply lines which extend from the electrodes, are on opposite sides in the lengthwise direction.

34. The image heating device according to claim 33, wherein the connection positions are on opposite sides in the lengthwise direction in both the first and second heating blocks.

35. The image heating device according to claim 33, wherein a heating block having the opposite connection positions is the second heating block, and the connection positions of the first heating block are at a center of the first conductive element and a center of the second conductive element in the lengthwise direction.

36. The image heating device according to claim 32, further comprising an endless belt with its inner surface in contact with the heater, and a nip portion forming member configured to form a nip portion which conveys the recording sheet, together with the heater through the endless belt.

\* \* \* \* \*