



US009228638B2

(12) **United States Patent**  
**Matsumoto**

(10) **Patent No.:** **US 9,228,638 B2**  
(45) **Date of Patent:** **Jan. 5, 2016**

(54) **SHIFT DRIVE MECHANISM FOR MULTI-SPEED TRANSMISSION**

(56) **References Cited**

(71) Applicant: **HONDA MOTOR CO., LTD.**, Tokyo (JP)

(72) Inventor: **Shinya Matsumoto**, Wako (JP)

(73) Assignee: **HONDA MOTOR CO., LTD.**, Tokyo (JP)

(\*) Notice: Subject to any disclaimer, the term of this patent is extended or adjusted under 35 U.S.C. 154(b) by 93 days.

U.S. PATENT DOCUMENTS

3,274,843	A *	9/1966	Luebke	74/335
5,150,637	A *	9/1992	Ninomiya et al.	74/335
6,439,075	B1 *	8/2002	Koyama et al.	74/473.36
6,595,078	B2 *	7/2003	Arakawa	74/337.5
7,600,446	B2 *	10/2009	Mizuno et al.	74/473.1
8,215,196	B2 *	7/2012	Buck et al.	74/335
8,250,939	B2 *	8/2012	Hayakawa et al.	74/335
8,286,523	B2 *	10/2012	Hayakawa et al.	74/335
8,387,477	B2 *	3/2013	Ieda et al.	74/335
8,505,403	B2 *	8/2013	Bowen et al.	74/335
2001/0025535	A1 *	10/2001	Kamiya	74/335

(Continued)

(21) Appl. No.: **13/962,329**

(22) Filed: **Aug. 8, 2013**

(65) **Prior Publication Data**

US 2014/0053671 A1 Feb. 27, 2014

(30) **Foreign Application Priority Data**

Aug. 23, 2012 (JP) ..... 2012-184478

(51) **Int. Cl.**

**F16H 59/00** (2006.01)  
**F16H 3/08** (2006.01)  
**F16H 3/083** (2006.01)  
**F16H 63/30** (2006.01)

(52) **U.S. Cl.**

CPC ..... **F16H 3/08** (2013.01); **F16H 3/083** (2013.01); **F16H 2063/3096** (2013.01); **Y10T 74/19251** (2015.01)

(58) **Field of Classification Search**

CPC ..... **F16H 3/08**; **F16H 3/089**; **F16H 3/006**  
USPC ..... **74/333, 335, 337.5**  
See application file for complete search history.

FOREIGN PATENT DOCUMENTS

JP 2008-151275 7/2008  
JP 2010-078050 4/2010

Primary Examiner — William Kelleher  
Assistant Examiner — Zakaria Elahmadi

(74) Attorney, Agent, or Firm — Rankin, Hill & Clark LLP

(57) **ABSTRACT**

A shift drive mechanism in which a special constant-meshing-type multi-speed transmission can be applied to a transmission case of a constant-meshing-type multi-speed transmission of a general type. In a shift drive mechanism of a multi-speed transmission where the transmission is configured such that a control rod is movable in the axial direction on a hollow-shaft center axis of a gear shaft formed in a hollow shape so that an engagement changeover mechanism is driven to perform a gear shift, and a shift pin, which is guided by a shift drum provided near a periphery of the gear shaft, moves the control rod in the axial direction, an intermittent drive mechanism intermittently rotates the shift drum for every position of each gear speed by transmitting the reciprocating rotation of a shift spindle, which is connected to a gear shift operating member, is arranged between the shift spindle and the shift drum.

**16 Claims, 7 Drawing Sheets**

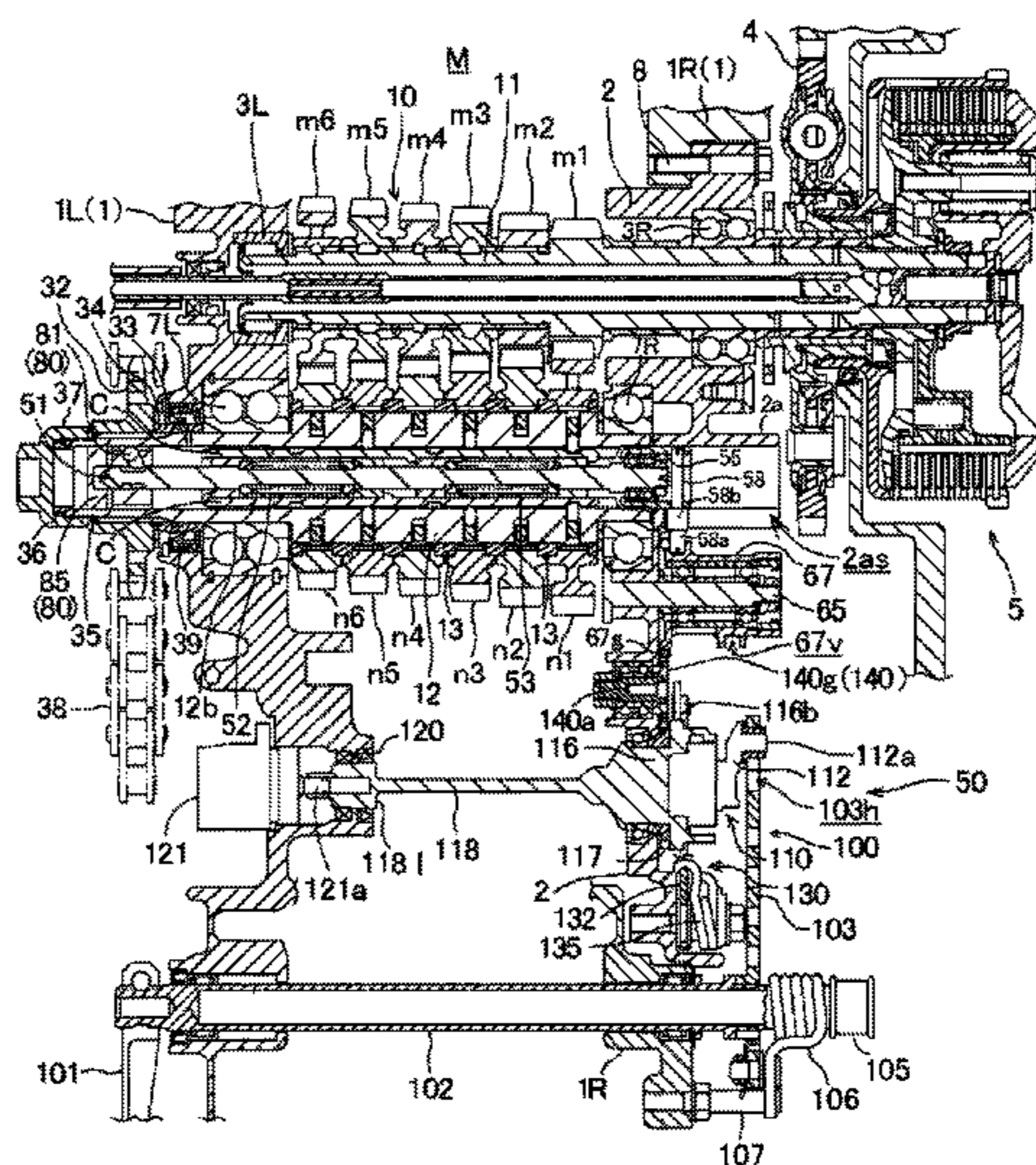

(56)

**References Cited**

U.S. PATENT DOCUMENTS

2002/0062703	A1 *	5/2002	Arakawa	74/337.5	2010/0071493	A1 *	3/2010	Matsumoto	74/337.5
2002/0144564	A1 *	10/2002	Luh	74/337.5	2010/0218630	A1 *	9/2010	Matsumoto et al.	74/333
2009/0008206	A1 *	1/2009	Bowen	192/48.2	2011/0023639	A1 *	2/2011	Matsumoto	74/337.5
2010/0071492	A1 *	3/2010	Matsumoto	74/337.5	2011/0252920	A1 *	10/2011	Bowen et al.	74/665 F
					2012/0152046	A1 *	6/2012	Matsumoto et al.	74/333
					2012/0240702	A1 *	9/2012	Tokito	74/337.5
					2013/0239717	A1 *	9/2013	Bowen et al.	74/335

\* cited by examiner

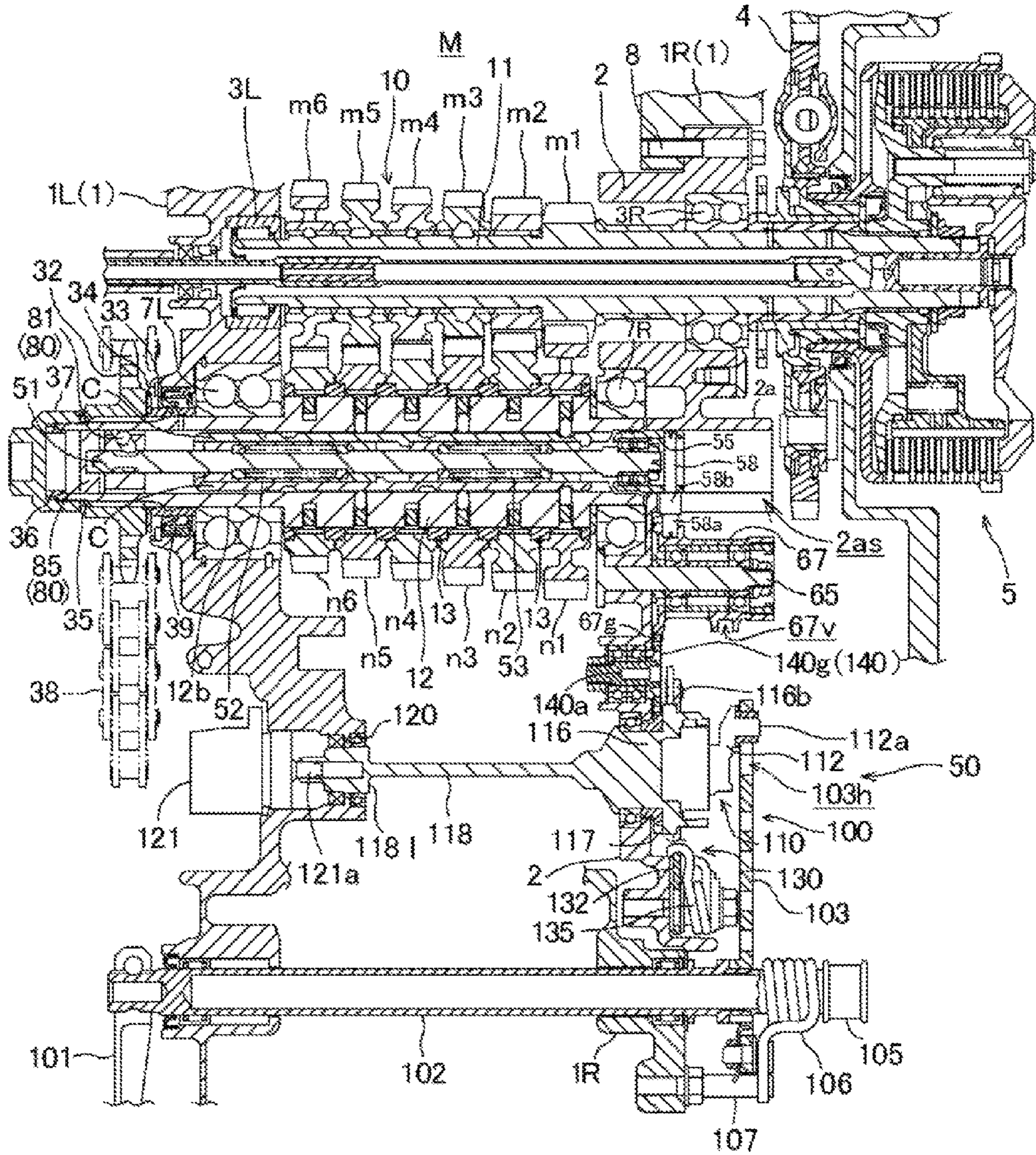

FIG. 1

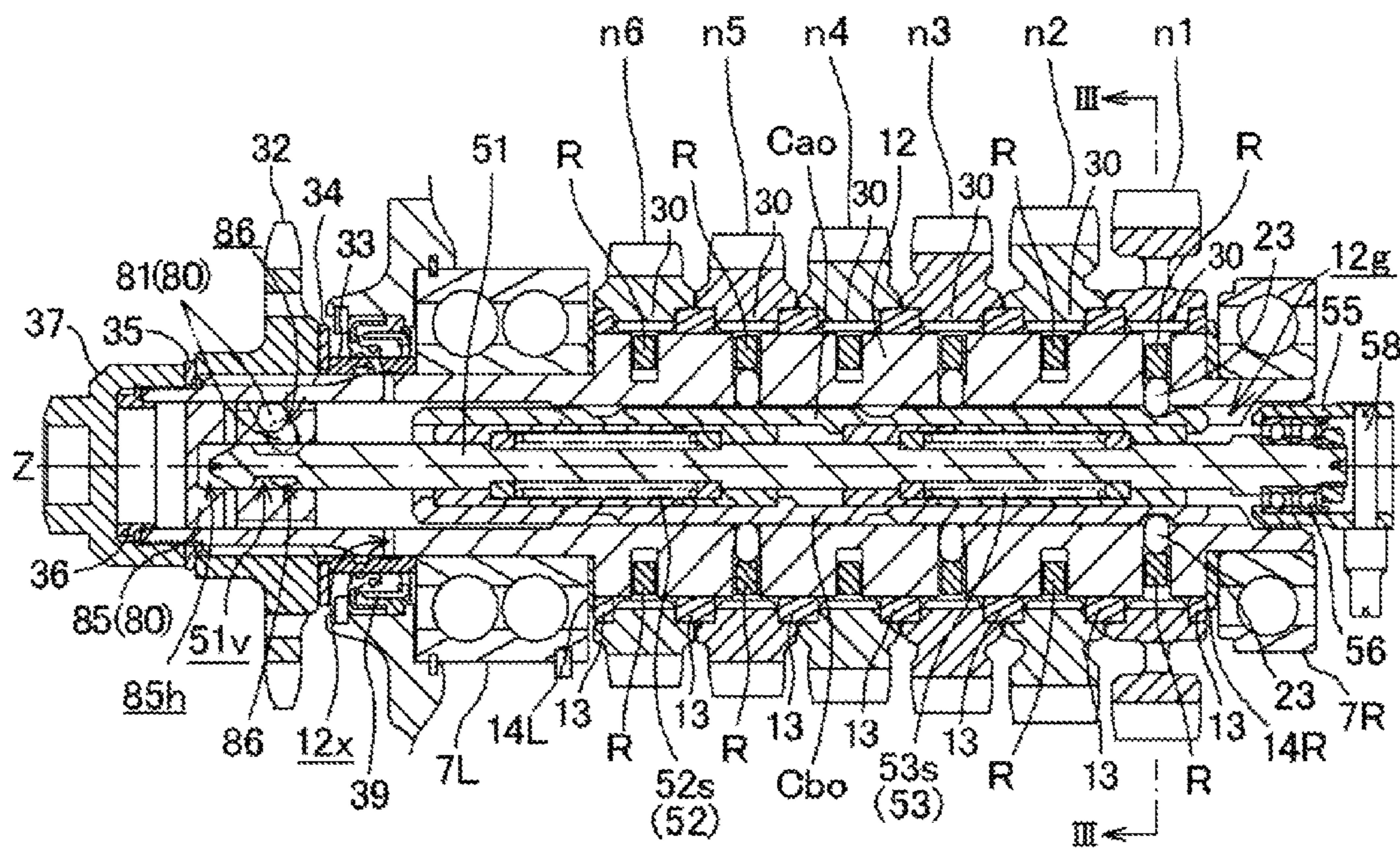

FIG. 2

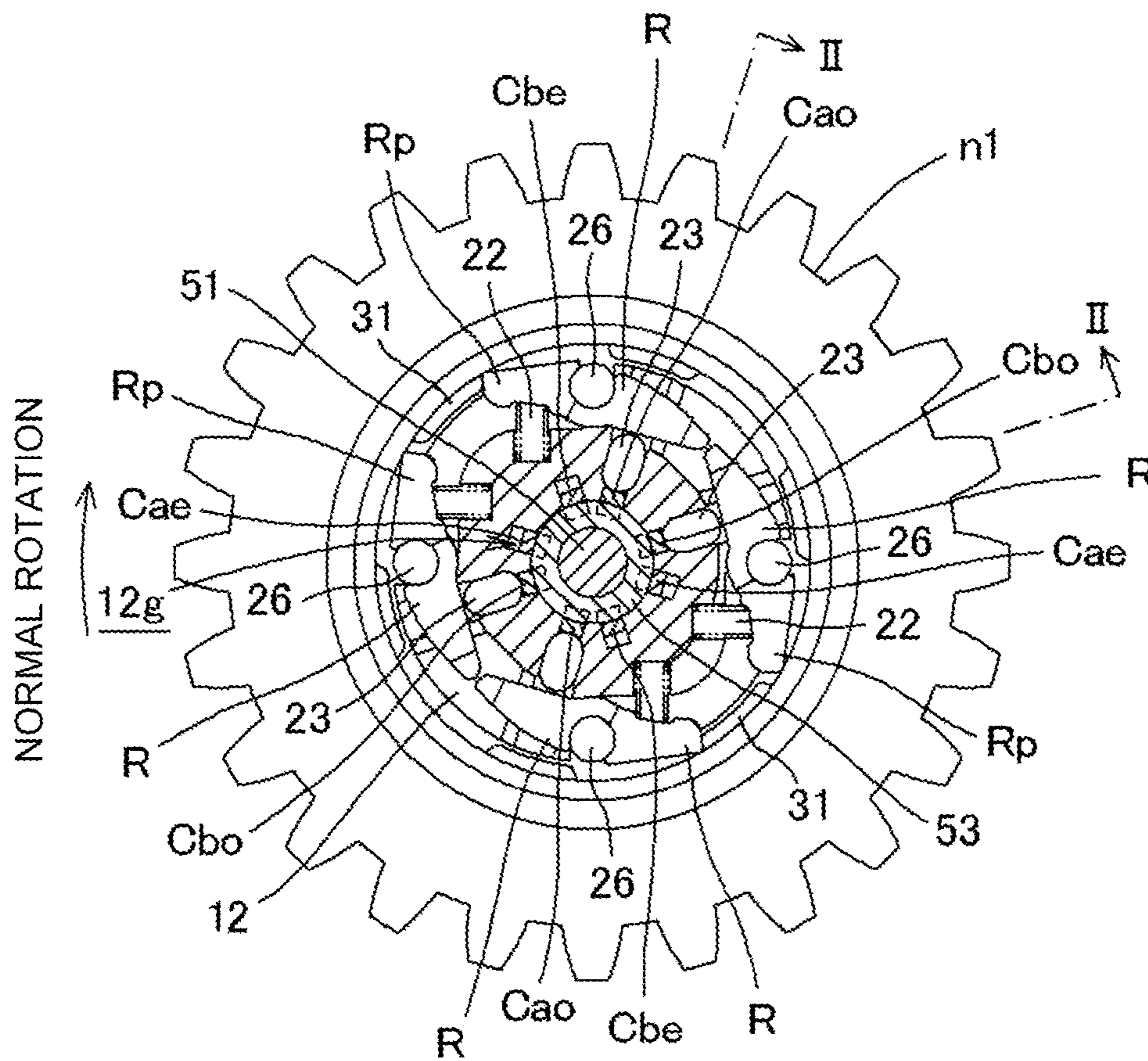
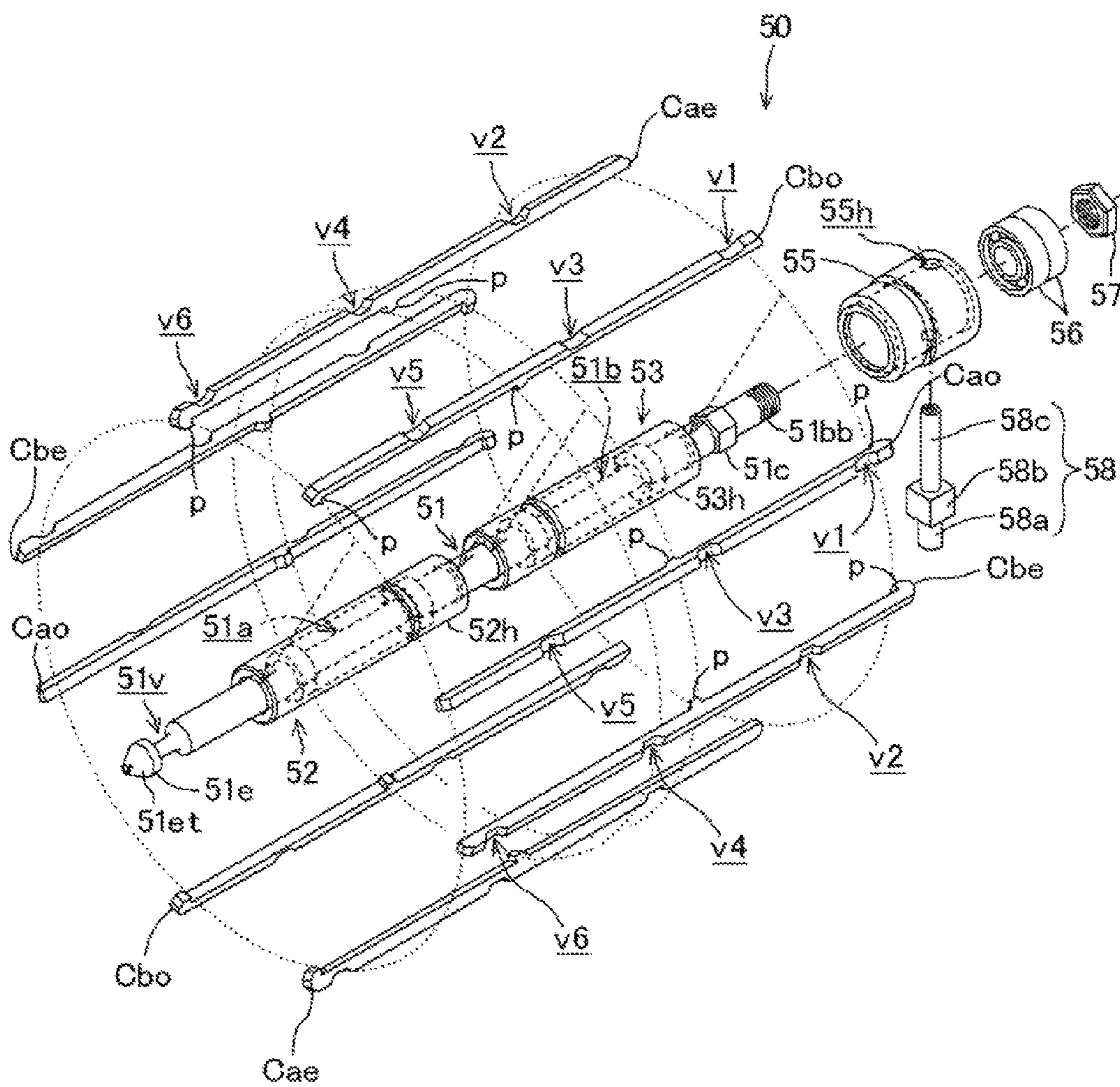

FIG. 3

FIG. 4



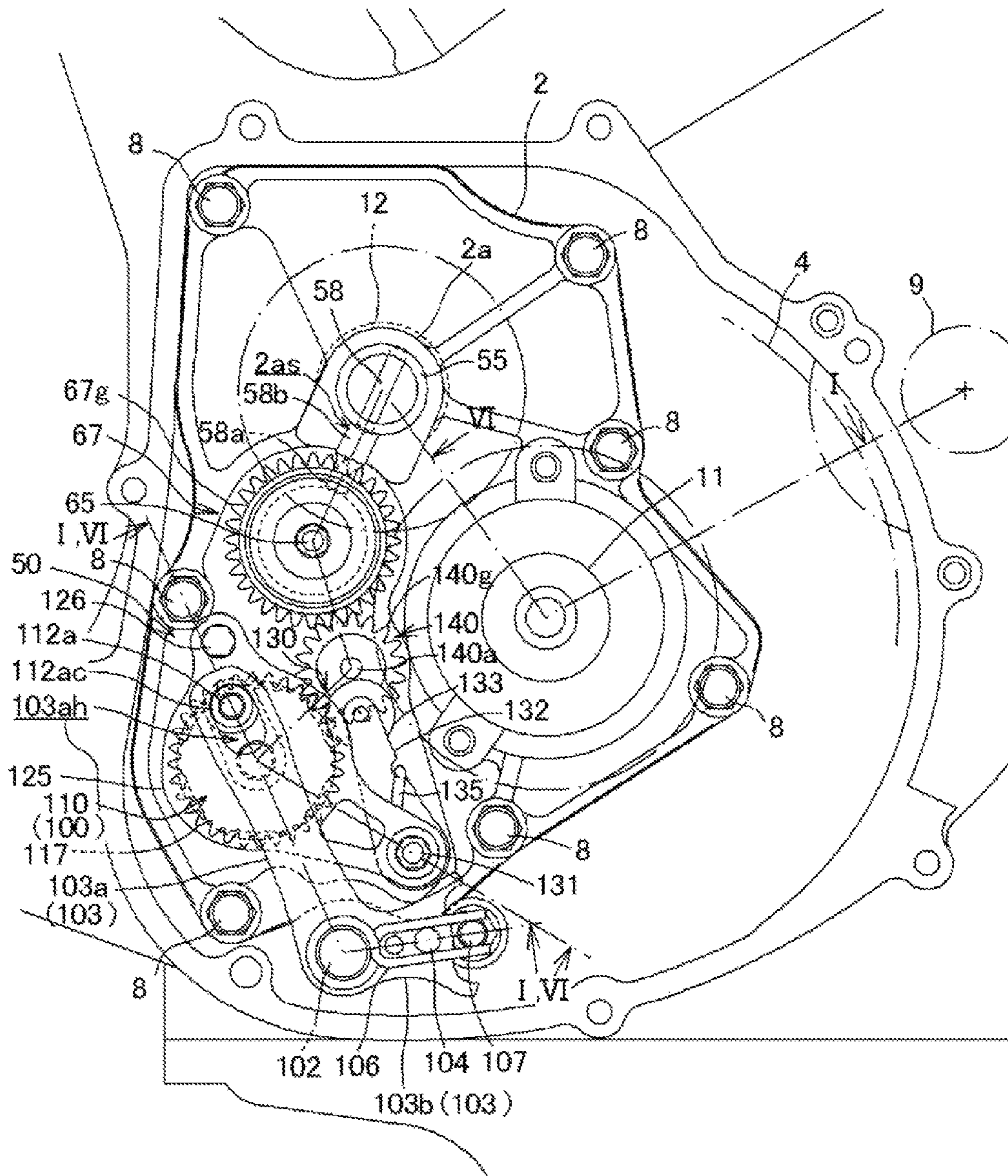

FIG. 5

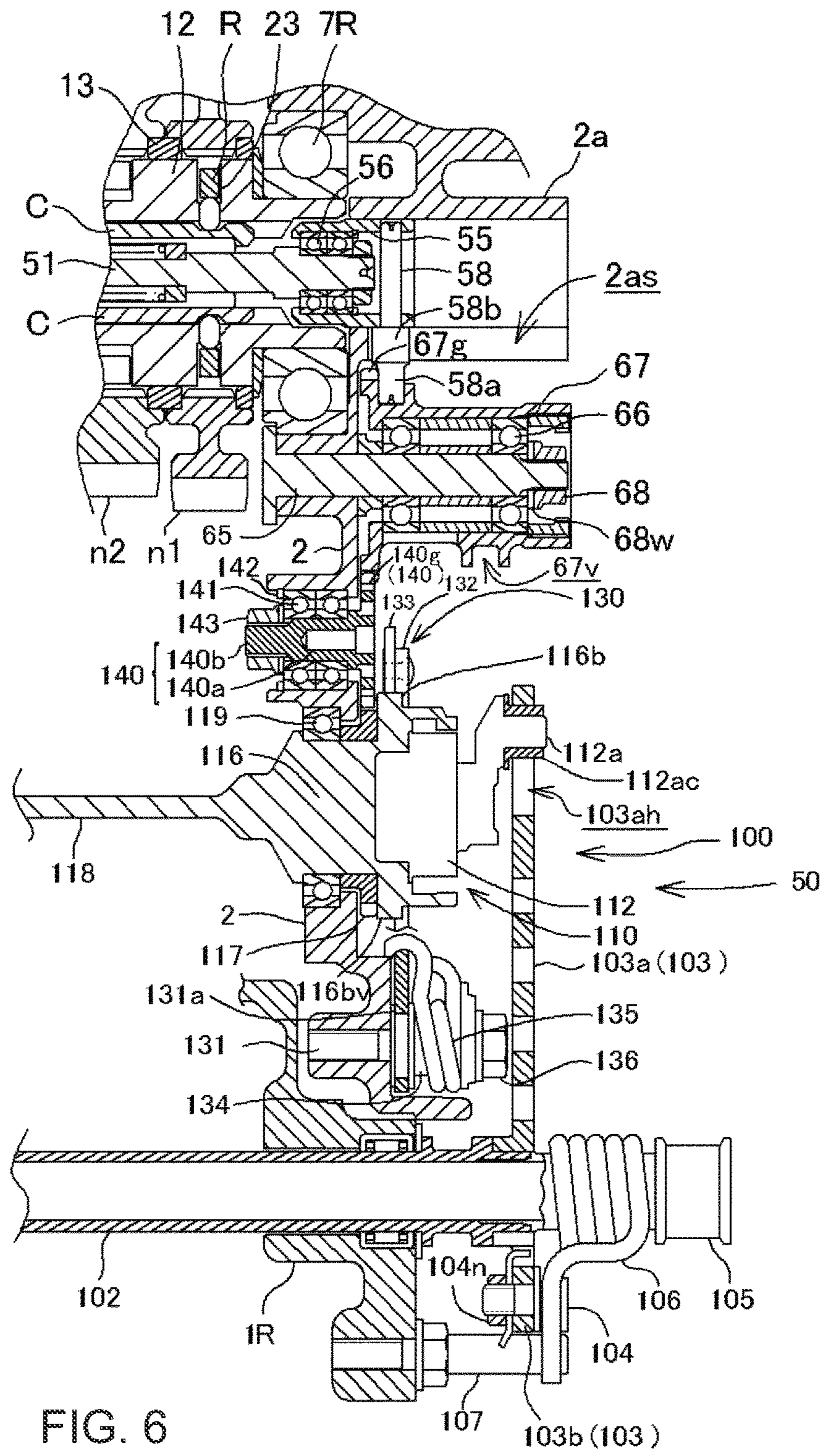



FIG. 7A

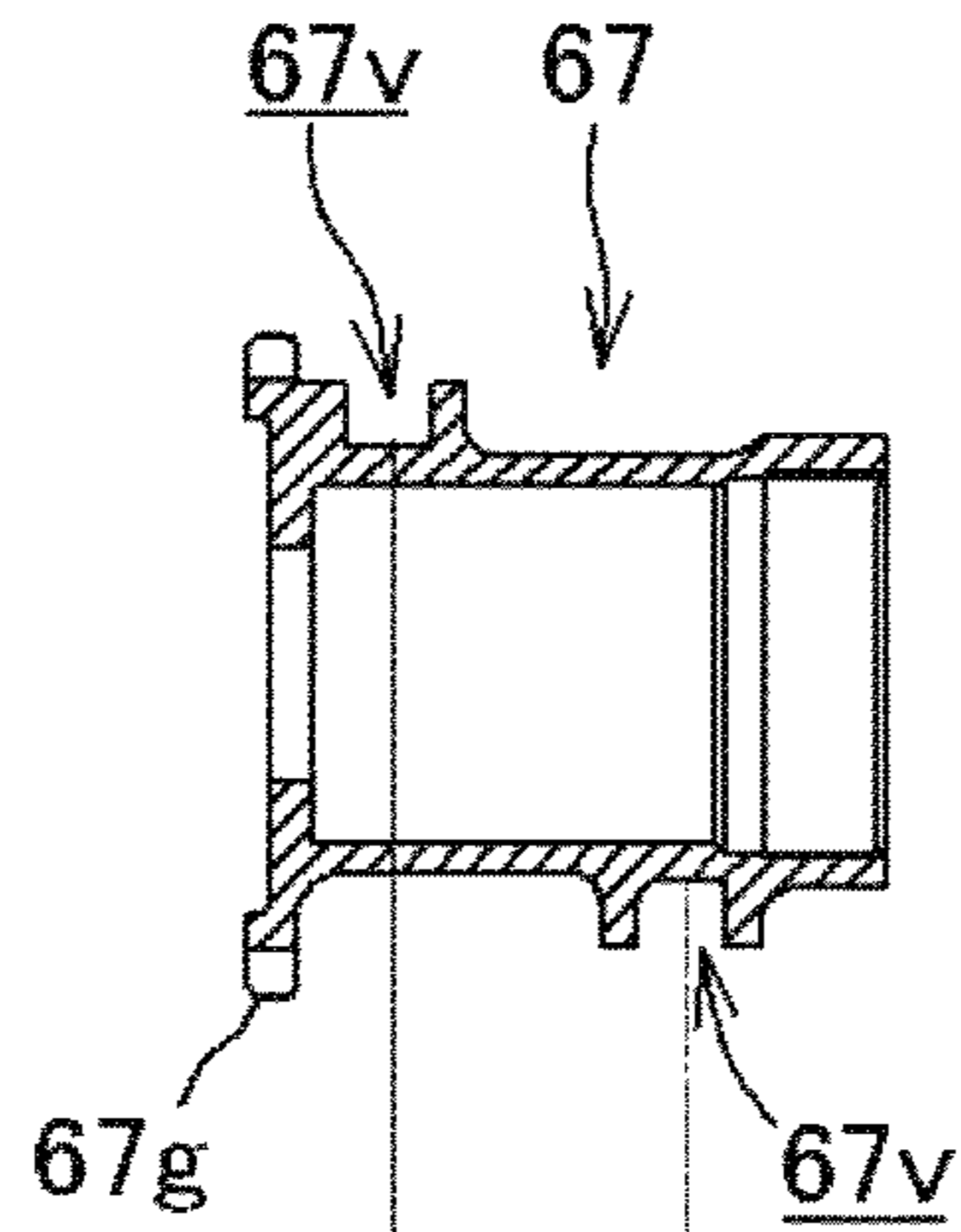
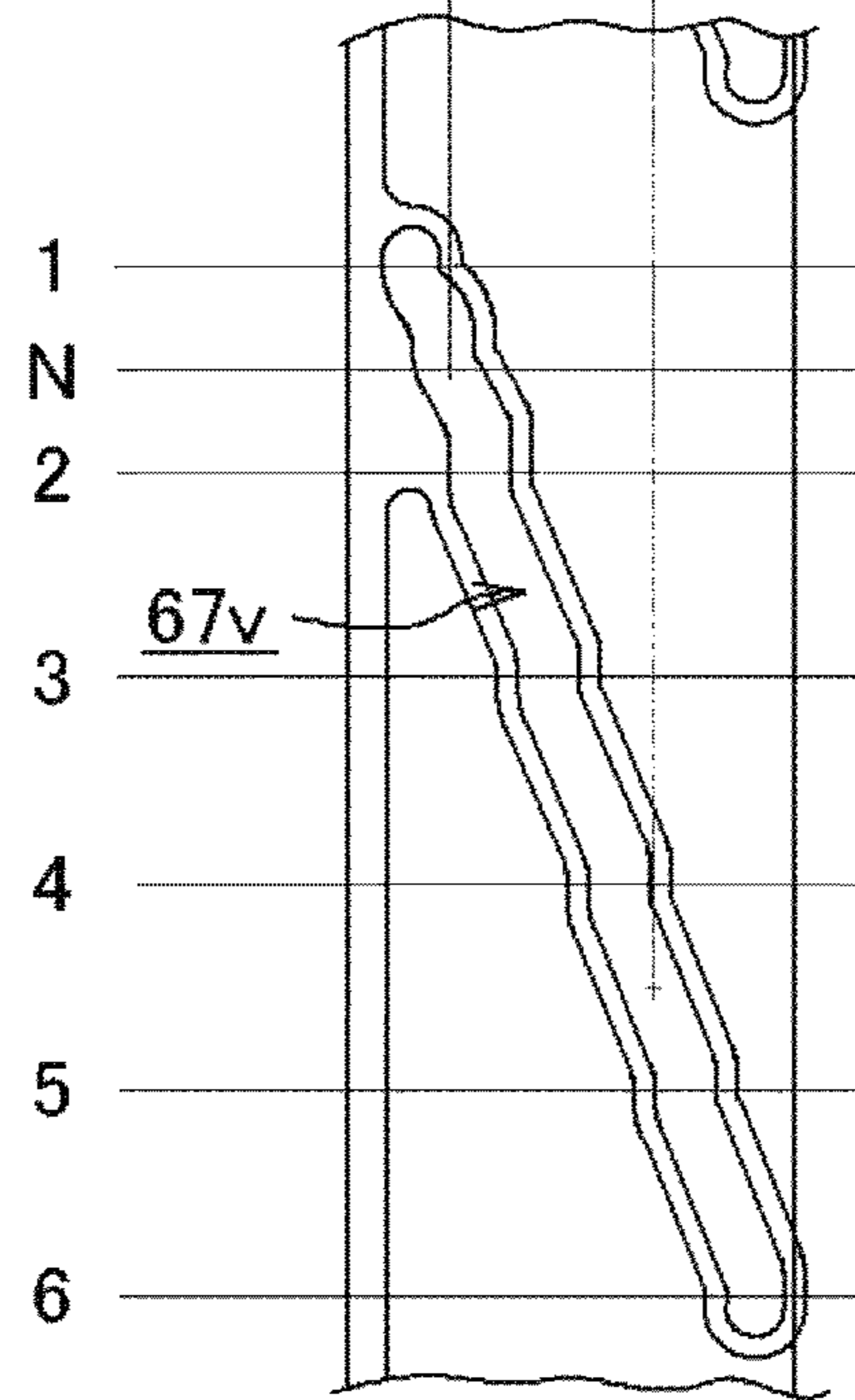

FIG. 7B



## SHIFT DRIVE MECHANISM FOR MULTI-SPEED TRANSMISSION

### BACKGROUND OF THE INVENTION

#### 1. Field of the Invention

The present invention relates to a constant-meshing-type multi-speed transmission.

#### 2. Description of Related Art

In a constant-meshing-type multi-speed transmission where drive gears on a main gear shaft and driven gears on a counter gear shaft are in a constant meshing state for every gear speed, in general, the gear shift is performed in such a manner that, when a shift pedal is operated, a dog clutch is moved in the axial direction so that the meshing of gears which effectively transmit power from a main gear shaft to a counter gear shaft is selected (see JP-A-2008-151275, for example).

In the case of the constant-meshing-type multi-speed transmission of a general type described in JP-A-2008-151275, due to the rotation of a shift spindle driven in response to a shift operation of a shift pedal, a shift drum is rotated by way of an intermittent drive mechanism, a shift fork is axially moved by being guided by a shift guide groove formed on an outer peripheral surface of the shift drum, and the shift fork moves a shifter gear and a shifter provided with a dog clutch mechanism on the main gear shaft and the counter gear shaft in the axial direction thus performing the gear shift.

Accordingly, the relatively large shift fork moving mechanism is interposed between the shift spindle and the counter gear shaft (and the main gear shaft) positioned on a lower side of the transmission and hence, the shift spindle and the counter gear shaft (and the main gear shaft) are largely spaced apart from each other. A transmission case rotatably supports the shift spindle and the counter gear shaft (and the main gear shaft) which are spaced apart from each other in such a manner.

On the other hand, with respect to the constant-meshing-type multi-speed transmission, there has been known a special multi-speed transmission where either the main gear shaft or the counter gear shaft rotatably supports gears in a relatively rotatable manner, and a control rod which moves axially in the inside of the gear shaft selectively operates engaging members arranged in the inside of the gear shaft so as to make a desired gear engage with the gear shaft thus establishing a gear speed. The applicant of this application previously filed the patent application on this special constant-meshing-type multi-speed transmission (see JP-A-2010-78050).

In the case of the special constant-meshing-type multi-speed transmission described in JP-A-2010-78050, a shift drum is provided adjacent to an end portion of the counter gear shaft in which the control rod passes through, and a small shift pin, which engages with the end portion of the control rod, is guided by a shift guide groove formed on the shift drum, and a gear shift is performed by the axial movement of the control rod.

Due to such a constitution, a relatively large shift fork moving mechanism such as one disclosed in JP-A-2008-151275 is unnecessary and hence, the miniaturization and reduction in weight of the multi-speed transmission can be realized.

### SUMMARY OF THE INVENTION

The constitution where a power unit provided with a transmission case constituting a part of the constant-meshing-type

multi-speed transmission of a general type has been adopted in general up to now so that if the special constant-meshing-type multi-speed transmission described in JP-A-2010-78050 is also applicable to this same transmission case, then this transmission case can be used as it is without changing the constitution of a vehicle and thereby manufacturing cost can be largely reduced.

However, with respect to the transmission case of the constant-meshing-type multi-speed transmission of a general type, as described above, there has been a case where the shift spindle and the counter gear shaft (and the main gear shaft) are rotatably supported in such a manner that the shift spindle and the counter gear shaft (and the main gear shaft) are largely spaced apart from each other. To apply the special constant-meshing-type multi-speed transmission having the shift drum arranged adjacent to the end portion of the counter gear shaft to this transmission case, the constitution of the shift drive system, which intermittently transmits power from the shift spindle that is rotated manually to the shift drum arranged adjacent to the counter gear shaft becomes important. However, the structure of the shift drive system is not disclosed clearly in JP-A-2010-78050.

The invention has been made in view of the above, and it is an object of the invention to provide a shift drive mechanism where a special constant-meshing-type multi-speed transmission can be applied to a transmission case of a constant-meshing-type multi-speed transmission of a general type.

In accordance with the present invention, a shift drive mechanism of a multi-speed transmission, where the transmission is configured such that:

a group of gears formed of a plurality of drive gears and a group of gears formed of a plurality of driven gears are rotatably supported on gear shafts arranged parallel to each other respectively in such a state where the drive gears and the driven gears are meshed with each other for every gear speed,

one group of gears formed of the plurality of gears out of the group of gears formed of the plurality of drive gears and the group of gears formed of the plurality of driven gears is fixed to one gear shaft, and an engagement changeover mechanism, which changes over the engagement between the other gear shaft and the respective gears for every gear is provided between the other group of gears formed of the plurality of gears and the other gear shaft, and

a control rod is movable in the axial direction on a hollow-shaft center axis of the other gear shaft formed in a hollow shape so that the engagement changeover mechanism is driven whereby a gear shift is performed, and

a shift pin, which is engaged with a shift guide groove formed on an outer periphery of a shift drum arranged in the vicinity of a periphery of the other gear shaft and is guided due to the rotation of the shift drum, moves the control rod in the axial direction, wherein

an intermittent drive mechanism, which intermittently rotates the shift drum for every position of each gear speed by transmitting the reciprocating rotation of a shift spindle, which is connected to a gear shift operating member, is arranged between the shift spindle and the shift drum.

Since the intermittent drive mechanism is arranged between the shift spindle and the shift drum, the shift spindle and the shift drum can be suitably spaced apart from each other. Accordingly, the special constant-meshing-type multi-speed transmission where the shift drum is arranged in the vicinity of the periphery of the counter gear shaft (and the

3

main gear shaft) which is spaced apart from the shift spindle can be easily applied to a transmission case of a constant-meshing-type multi-speed transmission of a general type where a shift spindle which is positioned on a lower side of a general type and a counter gear shaft (a the main gear shaft) arranged above the shift spindle are rotatably supported in a relatively largely spaced-apart manner.

Further, the intermittent drive mechanism, which intermittently transmits the rotation of the shift spindle to the shift drum for each gear speed, can be easily arranged by making use of a space formed between the shift spindle and the counter gear shaft (and the main gear shaft).

In further accordance with the invention, the intermittent drive mechanism, which transmits power only during the outgoing rotation to a downstream-side rotary member with respect to the reciprocating rotation of an upstream-side rotary member, is provided between the shift spindle and the shift drum, and the rotation of a downstream-member-side drive gear, which is formed integrally with the downstream-side rotary member, is transmitted to a drum-side driven gear, which is integrally formed on the shift drum, due to the meshing of the gears. Due to such a constitution, by arranging the intermittent drive mechanism between the shift spindle and the shift drum thus interposing the gear system which transmits power to the drum-side driven gear from the downstream-member-side drive gear, the intermittent drive mechanism can be properly positioned also in the transmission case in which the shift spindle and the counter gear shaft (and the main gear shaft) are rotatably supported in a relatively largely spaced-apart manner and hence, the shift spindle and the shift drum can be easily arranged.

In further accordance with the invention, the intermittent drive mechanism includes a detent mechanism where a flower-shaped cam is coaxially and integrally formed with the downstream-side rotary member, and the flower-shaped cam is positioned and held at the predetermined rotational position together with the downstream-side rotary member by pushing a roller by a biasing device toward a predetermined uneven cam surface of the flower-shaped cam where a plurality of detent recessed portions are sequentially formed on the uneven cam surface in the circumferential direction. Accordingly, the rotation of the shift spindle can be intermittently transmitted to the shift drum so that the shift drum can be surely positioned for each gear speed.

In further accordance with the present invention, an intermediate gear is interposed between the downstream-member-side drive gear and the drum-side driven gear. Accordingly, the degree of freedom in position where the downstream-side rotary member, which is integrally formed with the downstream-member-side drive gear, and the intermittent drive mechanism is high so that the shift spindle and the shift drum can be more easily arranged also in the transmission case in which the shift spindle and the counter gear shaft (and the main gear shaft) are rotatably supported in a relatively largely spaced-apart manner.

In further accordance with the present invention, the shift drive mechanism includes a shift arm, which has a proximal end portion thereof fixedly mounted on the shift spindle and is tilted integrally with the shift spindle in a reciprocating manner, and the tilting distal end portion of the shift arm rotates the upstream-side rotary member. Accordingly, an amount of rotation of the upstream-side rotary member and an amount of rotation of the downstream-side rotary member generated by the tilting of the shift arm are determined so that an intermittent rotational amount of the shift drum to which the rotation is transmitted from the downstream-side rotary member by way of a gear system can be properly determined.

4

In further accordance with the present invention, the multi-speed transmission is housed in a transmission case, and the shift drum is rotatably supported on a holder side wall member, which is detachably mounted on the transmission case and forms a body separate from the transmission case, and the upstream-side rotary member and the downstream-side rotary member are coaxially and rotatably supported. Accordingly, a unit is formed by incorporating the shift drum and the intermittent drive mechanism into the holder side wall member so that these parts can be handled integrally thus enhancing assembling property.

In further accordance with the present invention, a connecting rod portion, which extends on a rotation center axis from the downstream-side rotary member rotatably supported on the holder side wall member, is coaxially joined to an operating shaft of a gear position sensor mounted on the transmission case. Accordingly, the transmission case has tolerance in space compared to the holder side wall member and hence, the gear position sensor can be easily arranged. The downstream-side rotary member, which is provided with the flower-shaped cam, which determines the rotational position by surely performing the intermittent driving is connected to the gear position sensor by way of the connecting rod portion, and the rotation of the downstream-side rotary member provided with the flower-shaped cam directly operates the gear position sensor and hence, the gear position can be properly and accurately detected.

In further accordance with the present invention, the intermediate gear is formed in a bolt shape where a head portion having an enlarged diameter is formed on an intermediate shaft portion, and a teeth portion is formed on an outer periphery of the head portion. The intermediate shaft portion is rotatably supported on the holder side wall member via a bearing. Accordingly, the intermediate gear can be arranged in a compact manner thus realizing the reduction in weight.

In further accordance with the present invention, a gear train where the downstream-member-side drive gear, the intermediate gear and the drum-side driven gear are meshed with each other sequentially is arranged along an outer surface of the holder side wall member; the flower-shaped cam is arranged outside the downstream-member-side drive gear in the axial direction; and, the roller, which is pushed to an uneven cam surface of the flower-shaped cam by the biasing device overlaps with the intermediate gear as viewed in the axial direction. Accordingly, the gear train constituted of the downstream-member-side drive gear, the intermediate gear and the drum-side driven gear is arranged along the outer surface of the holder side wall member, the flower-shaped cam is arranged outside the downstream-member-side drive gear, and the roller, which is pushed to the uneven cam surface of the flower-shaped cam, is positioned outside the intermediate gear and hence, the shift drive mechanism can be constituted in a compact manner.

#### BRIEF DESCRIPTION OF THE DRAWINGS

FIG. 1 is a cross-sectional view of a multi-speed transmission according to one embodiment of the invention.

FIG. 2 is a cross-sectional view (cross-sectional view taken along a line II-II in FIG. 3) showing a counter gear shaft and the structure around the counter gear shaft.

FIG. 3 is a cross-sectional view taken along a line III-III in FIG. 2.

FIG. 4 is an exploded perspective view showing a state where a lost motion mechanism is assembled into a control rod, and also showing a cam rod and the like.

## 5

FIG. 5 is a right side view showing a shift drive mechanism of a power unit.

FIG. 6 is a cross-sectional view taken along a line VI-VI in FIG. 5.

FIG. 7A is a cross-sectional view of a shift drum and FIG. 7B is a developed view of an outer peripheral surface of the shift drum.

#### DETAILED DESCRIPTION OF THE PREFERRED EMBODIMENTS

Hereinafter, one embodiment of the invention is explained in conjunction with FIG. 1 to FIG. 7. A multi-speed transmission 10 according to this embodiment is configured such that the multi-speed transmission 10 is incorporated into a power unit mounted on a motorcycle together with an internal combustion engine. In this specification, "front", "rear", "left" and "right" are determined with reference to the vehicle.

FIG. 1 is a cross-sectional view of the multi-speed transmission 10. As shown in FIG. 1, the multi-speed transmission 10 is mounted on an engine case 1 that is used in common by the internal combustion engine so that the engine case also constitutes a transmission case.

In the engine case (transmission case) 1 constituted by merging a left engine case (left transmission case) 1L and a right engine case (right transmission case) 1R, which have the left and right split structure, a transmission chamber M is formed. A main gear shaft 11 and a counter gear shaft 12 are rotatably supported in the transmission chamber M such that the main gear shaft 11 and the counter gear shaft 12 are arranged parallel to each other and are directed in the lateral direction.

The main gear shaft 11 is rotatably supported on a side wall of the left engine case (left transmission case) 1L and a holder side wall member 2, which forms a body separate from the right engine case (right transmission case) 1R, by way of bearings 3L, 3R. A multi-disc-type friction clutch 5 is mounted on a right end portion of the main gear shaft 11, which passes through the right bearing 3R and projects from the transmission chamber M.

On a left side of the friction clutch 5, a primary driven gear 4 to which the rotation of a crankshaft 9 (see FIG. 5) is transmitted is rotatably supported on the main gear shaft 11.

The rotation of the crankshaft of the internal combustion engine is transmitted to the main gear shaft 11 from the primary driven gear 4 by way of the friction clutch 5 in an engaging state.

On the other hand, the counter gear shaft 12 is also rotatably supported on the side wall of the left engine case 1L and the holder side wall member 2 of the right engine case 1R by way of bearings 7L, 7R. A cylindrical collar member 33 is fitted on a left end portion of the counter gear shaft 12, which passes through the left bearing 7L and projects from the transmission chamber M, in a state where the collar member 33 is brought into contact with an inner race of the left bearing 7L. A plurality of supply oil introducing holes 12<sub>x</sub> are formed in a portion of the counter gear shaft 12 on which the collar member 33 is fitted in a penetrating manner in the radial direction. Introducing holes are also formed in the collar member 33 corresponding to the supply oil introducing holes 12<sub>x</sub>, and an outer periphery of the collar member 33 is covered with an annular sealing member 39.

An output sprocket 32 is mounted on the counter gear shaft 12 by spline fitting in a state where a disc spring 34 is sandwiched between the output sprocket 32 and the collar member 33. The output sprocket 32 is pushed from the outside by a cap nut 37, which is threadedly engaged with a shaft end of the

## 6

counter gear shaft 12 by way of a spacer 35, in a state where an interposing member 36 is interposed between the cap nut 37 and the shaft end of the counter gear shaft 12.

A drive chain 38 is wound around the output sprocket 32 mounted in this manner, and the drive chain 38 is wound around a sprocket for driving a rear wheel disposed on a rear side (not shown) so that rotational power of the counter gear shaft 12 is transmitted to the rear wheel whereby the vehicle travels.

A group of drive shift gears m is mounted on the main gear shaft 11 between the left and right bearings 3L, 3R in a state where the group of drive shift gears m is integrally rotatable with the main gear shaft 11.

The first drive shift gear m1 is integrally formed with the main gear shaft 11 along the right bearing 3R, and the second, third, fourth, fifth and sixth drive shift gears m2, m3, m4, m5, m6 having diameters that are increased sequentially from the right to the left are engaged with splines formed on the main gear shaft 11 between the first drive shift gear m1 and the left bearing 3L by spline fitting.

On the other hand, a group of driven shift gears n is rotatably supported on the counter gear shaft 12 by way of annular bearing collar members 13 between the left and right bearings 7L, 7R.

To explain the structure in conjunction with FIG. 2, five bearing collar members 13 are exteriorly mounted on the counter gear shaft 12 at equal intervals between the bearing collar member 13 on a right end, which is exteriorly mounted on the counter gear shaft 12 by way of the collar member 14R interposed between a left side of the right bearing 7R and the bearing collar member 13 on a left end, which is exteriorly mounted on the counter gear shaft 12 by way of the collar member 14L interposed between a right side of the left bearing 7L and the bearing collar member 13. The first, second, third, fourth, fifth and sixth driven shift gears n1, n2, n3, n4, n5, n6, which sequentially decrease diameters thereof in order from the right to the left, are rotatably supported on the counter gear shaft 12 such that each shift gear straddles between the bearing collar members 13, 13 arranged adjacent to each other among seven bearing collar members 13 in total.

The first, second, third, fourth, fifth and sixth drive shift gears m1, m2, m3, m4, m5, m6, which are rotated integrally with the main gear shaft 11, are constantly meshed with the corresponding first, second, third, fourth, fifth and sixth driven shift gears n1, n2, n3, n4, n5, n6, which are rotatably supported on the counter gear shaft 12, respectively.

The meshing between the first drive shift gear m1 and the first driven shift gear n1 constitutes the first speed which exhibits the largest speed reduction ratio, the meshing between the sixth drive shift gear m6 and the sixth driven shift gear n6 constitutes the sixth speed which exhibits the smallest speed reduction ratio, and the second speed, the third speed, the fourth speed and the fifth speed are constituted between the first speed and the sixth speed such that the speed reduction ratio is sequentially decreased.

On the counter gear shaft 12, the odd-numbered gears (first, third and fifth driven shift gears n1, n3, n5) where the gear speed is the odd number and even-numbered gears (second, fourth and sixth driven shift gears n2, n4, n6) where the gear speed is the even number are alternately arranged.

An engaging device 20, which is engageable with respective driven shift gears n, is assembled into the counter gear shaft 12 having a hollow cylindrical shape as described later. Eight pieces (two pieces for each of four kinds) of cam rods C (Cao, Cao, Cae, Cae, Cbo, Cbo, Cbe, Cbe), which constitute one constitutional element of the engaging device 20 (described later), are axially movably arranged in the counter

gear shaft **12** in a state where the cam rods C are fitted in 8 pieces of cam guide grooves **12g** formed on a hollow inner peripheral surface of the counter gear shaft **12** in the circumferential direction (see FIG. 2, FIG. 3).

A control rod **51**, which performs a gear shift by driving the cam rods C, is inserted into the hollow center shaft of the counter gear shaft **12**. Movement of the control rod **51** in the axial direction moves the cam rods C in the axial direction in an interlocking manner by way of lost motion mechanisms **52, 53**.

To explain the structure in conjunction with FIG. 4, the control rod **51** has a circular columnar rod shape. Outer peripheral recessed portions **51a, 51b** having narrowed diameters respectively are formed on two left and right portions of the control rod **51** in the axial direction over a predetermined length respectively, and an outer peripheral recessed groove **51v** having a narrow width is formed just behind a distal end portion **51e** having a conically pointed tapered face **51et** on a left end thereof.

A male threaded end portion **51bb** on which male threads are formed is formed on a right end of the control rod **51**, and a nut portion **51c**, which has a hexagonal shape, is formed just behind the male threaded end portion **51bb**.

The lost motion mechanisms **52, 53** are assembled to the control rod **51** corresponding to the left and right outer peripheral recessed portions **51a, 51b** respectively.

The left and right lost motion mechanisms **52, 53** are provided by arranging the mechanism having the same structure in which a compressive coil spring is arranged on the left and right sides of the control rod **51**.

Eight pieces of cam rods C (Cao, Cao, Cae, Cae, Cbo, Cbo, Cbe, Cbe) are arranged at radial positions and are brought into contact with outer peripheral surfaces of spring holders **52h, 53h** of the lost motion mechanisms **52, 53** mounted in the left and right outer peripheral recessed portions **51a, 51b** of the control rod **51** (see FIG. 4).

The cam rod C is an angular columnar rod-like member that has a rectangular cross section and extends in an elongated manner in the axial direction. A cam face is formed on an outer peripheral surface of the cam rod C on a side opposite to an inner peripheral surface, which is brought into contact with the spring holders **52h, 53h**. A cam groove v is formed on desired three portions of the cam face and a pair of engaging pawls p is formed on the inner peripheral surface of the cam rod C in a projecting manner such that the engaging pawls P sandwich either one of the spring holders **52h, 53h** from left and right sides.

With respect to the odd-numbered cam rods Cao, Cbo where the cam grooves v1, v3, v5 are formed on three portions corresponding to the odd-numbered gears (the first, third and fifth driven shift gears n1, n3, n5), there are two kinds of cam rods, that is, the cam rod for normal rotation (a rotational direction where a force is applied to the counter gear shaft **12** from the driven shift gear n at the time of acceleration) and the cam rod for reverse rotation (a rotational direction where a force is applied to the counter gear shaft **12** from the driven shift gear n at the time of deceleration). Here, one odd-numbered cam rod Cao for normal rotation has the engaging pawls p, which are engaged with the right spring holder **53h** on the inner peripheral surface thereof, and the other odd-numbered cam rod Cbo for reverse rotation has engaging pawls p, which are engaged with the left spring holder **52h** on the inner peripheral surface thereof (see FIG. 4).

In the same manner, with respect to the even-numbered cam rods Cae, Cbe where the cam grooves v2, v4, v6 are formed on three portions corresponding to the even-numbered gears (the second, fourth and sixth driven shift gears n2,

n4, n6), there are two kinds of cam rods, that is, the cam rod for normal rotation and the cam rod for reverse rotation. Here, one even-numbered cam rod Cae for normal rotation has the engaging pawls p, which are engaged with the left spring holder **52h** on the inner peripheral surface thereof, and the other even-numbered cam rod Cbe for reverse rotation has the engaging pawls p, which are engaged with the right spring holder **53h** on the inner peripheral surface thereof (see FIG. 4).

Accordingly, along with the movement of the control rod **51** in the axial direction, the odd-numbered cam rod Cao for normal rotation and the even-numbered cam rod Cbe for reverse rotation are moved axially in an interlocking manner together with the spring holder **53h** by way of the compression coil spring **53s** of the right lost motion mechanism **53**, and the odd-numbered cam rod Cbo for reverse rotation and the even-numbered cam rod Cae for normal rotation are moved axially in an interlocking manner together with the spring holder **52h** by way of the coil spring **52s** of the left lost motion mechanism **52**.

In this manner, along with the movement of the control rod **51** in the axial direction, the cam rods C are axially moved in an interlocking manner by way of the lost motion mechanisms **52, 53**, and the movement of the cam rods C makes the respective driven shift gears n selectively engage with the counter gear shaft **12** by the engaging means **20** assembled into the counter gear shaft **12** so that the gear shift is performed.

To explain the engaging device **20** in conjunction with FIG. 3, tilting pawl members R are tiltably and pivotally supported by support shaft pins **26** respectively along an inner periphery of the driven shift gear n, and one end of the tilting pawl member R is pushed by a compression spring **22** and a pin member **23** is brought into contact with the other end of the tilting pawl member R. When the pin member **23** falls in any one of cam grooves v formed on the moving cam rod C, the tilting pawl member R is tilted by the compression spring **22**, and a projecting engaging pawl portion Rp engages with the engaging projecting portion **31** formed on the inner periphery of the driven shift gear n of corresponding gear speed so that the rotation of the driven shift gear n can be transmitted to the counter gear shaft **12**.

In a shift-up operation, the shift-up operation is performed in such a manner that in a state where the driven shift gear n is engaged with the tilting pawl member R, another driven shift gear n whose reduction ratio is smaller than a reduction ratio of the former driven shift gear n by one stage engages with the tilting pawl member R and hence, the mechanism is smoothly operated without requiring a force in the engagement and the release of the engagement, and a clutch for gear shift is unnecessary. Further, there is no loss time in a changeover time at the time of performing the shift-up operation, there is no leakage of the drive force and, further, a gear shift shock is also small and hence, the smooth shift-up operation can be performed.

Also in a shift-down operation, the shift-down operation is performed in such a manner that in a state where the driven shift gear n is engaged with the tilting pawl member R, the tilting pawl member R engages with another driven shift gear n whose reduction ratio is larger than a reduction ratio of the former driven shift gear n by one stage and hence, the mechanism is smoothly operated without requiring a force in the engagement and the release of the engagement, and a clutch for gear shift is unnecessary. Further, there is no loss time in a changeover time at the time of performing the shift-down operation, there is no leakage of the drive force and, further, a

gear shift shock is also small and hence, the smooth shift-down operation can be performed.

As described above, the multi-speed transmission of this embodiment is a special constant-meshing-type multi-speed transmission where the control rod **51**, which moves axially in the inside of the counter gear shaft **12**, selectively operates the engaging members **20** arranged in the inside of the counter gear shaft **12** so as to make the desired driven shift gear *n* engage with the counter gear shaft **12** thus establishing a gear speed.

In such a special constant-meshing-type multi-speed transmission, as shown in FIG. 4, a control rod operator **55** having a cylindrical shape is mounted on a right end portion of the control rod **51** which is arranged on a right side of the nut portion **51c** by way of ball bearings **56**, which are fitted in the inside of the control rod operator **55**.

The ball bearings **56** are two ball bearings connected to each other in the axial direction, are fitted on the right end portion of the control rod **51**, which is arranged on the right side of the nut portion **51c**, and are fastened between the nut portion **51c** and a nut **57**, which is threadedly engaged with a male threaded end portion **51bb**, in a sandwiched manner. Accordingly, the control rod operator **55** rotatably holds the right end portion of the control rod **51**.

A pin hole **55h** is formed in a cylindrical portion of the control rod operator **55**, which extends toward a right side from the threadedly engaged nut **57** in a state where the pin hole **55h** is formed in the diametrical direction, and a shift pin **58** passes through the pin hole **55h**. The control rod **51** is moved in the axial direction by way of the shift pin **58**.

On the other hand, as shown in FIG. 5, a shift spindle **102** is transversely mounted below the holder side wall member **2** in a state where the shift spindle **102** penetrates the left and right engine cases **1L**, **1R** in the lateral horizontal direction. The counter gear shaft **12** on an upper side and the shift spindle **102** on a lower side are relatively largely spaced apart from each other, and the left engine case **1L**, which rotatably supports the counter gear shaft **12** and the shift spindle **102**, which are spaced apart from each other, corresponds to a transmission case of a constant-meshing-type multi transmission of a general type, which performs a gear shift in such a manner that a shift fork moves a shifter gear provided with a dog clutch mechanism and a shifter in the axial direction.

A proximal end of a pedal link arm member **101** is mounted on a left end portion of the shift spindle **102**, which penetrates the left engine case **1L** by fitting, and the pedal link arm member **101** is connected with a shift pedal (not shown) by way of a link rod so that an operation of the shift pedal is transmitted as the rotation of the shift spindle **102**.

Accordingly, a shift drive mechanism **50** is a mechanism that transmits the rotation of the shift spindle **102** brought about by an operation of the shift pedal as the movement of the control rod **51** in the axial direction. The shift drive mechanism **50** is mounted on the holder side wall member **2** of the right engine case **1R**.

Hereinafter, the shift drive mechanism **50** is explained in conjunction with FIG. 5 to FIG. 6.

The holder side wall member **2** on which the shift drive mechanism **50** is mounted is fitted in an opening having a predetermined shape, which is formed on the side wall of the right engine case **1R** such that the holder side wall member **2** closes the opening, and a periphery of the holder side wall member **2** is fastened to the right engine case **1R** using a plurality of bolts **8** (see FIG. 5).

As shown in FIG. 5, the holder side wall member **2** is positioned behind the crankshaft **9** and, as explained previously, the right side portions of the main gear shaft **11** and the

counter gear shaft **12** are rotatably supported on the holder side wall member **2** by way of the bearings **3R**, **7R** respectively.

To explain the structure in conjunction with FIG. 5, the main gear shaft **11** is positioned at an approximately intermediate height of the holder side wall member **2** in the vertical direction in an offset manner toward a front side such that the main gear shaft **11** is arranged close to the crankshaft **9** arranged on a front side.

The counter gear shaft **12** is positioned at an oblique upper rear side as viewed from the main gear shaft **11**.

A guide sleeve portion **2a**, which has a deformed cylindrical shape and projects rightward is formed on an extension portion of the holder side wall member **2**, which extends from the counter gear shaft **12**, and a slit **2**, which extends in the lateral direction in an elongated manner, is formed in the guide sleeve portion **2a** by partially cutting out an oblique downward and rearward extending portion of the guide sleeve portion **2a**.

The control rod operator **55**, which rotatably holds the right end portion of the control rod **51**, which passes through the inside of the counter gear shaft **12**, is slidably inserted into the guide sleeve portion **2a**, and a projecting portion of the shift pin **58**, which penetrates the control rod operator **55** in the diametral direction passes through the slit **2** as.

A portion of the shift pin **58**, which projects from the control rod operator **55** and passes through the slit **2** as forms a slide portion **58b** having a rectangular parallelepiped shape, and a circular columnar engaging portion **58a**, is formed on the shift pin **58** in a projecting manner from the slide portion **58b**.

Since the slide portion **58b** of the shift pin **58** is slidably fitted in the slit **2** as formed in the guide sleeve portion **2a**, the rotation of the control rod operator **55** is restricted together with the shift pin **58**, and the control rod operator **55** slides only in the lateral axis direction.

A shift drum **67** is provided on a slit **2** as side along the guide sleeve portion **2a** of the holder side wall member **2**.

A shift guide groove **67v** is formed on an outer peripheral surface of the cylindrical portion of the shift drum **67** such that a spiral is drawn over approximately one turn.

As shown in FIG. 7B where an outer peripheral surface of the cylindrical portion of the shift drum **67** is shown in a developed manner, a return type gear shift method is provided where respective gear speed positions from the first speed position to the sixth speed position are formed for every predetermined rotational angle (for example, 60 degrees), and a neutral position is formed between the first speed position and the second speed position in such gear speed positions.

A drum-side driven gear **67g** is formed on an end portion of the cylindrical portion of the shift drum **67** by enlarging a diameter of the end portion in a flange shape.

The shift drum **67** is rotatably supported on the holder side wall member **2** adjacent to a slit **2** as side of the guide sleeve portion **2a** of the holder side wall member **2**.

Bearings **66** are fitted in the inside of the cylindrical portion of the shift drum **67**, the shift drum **67** is rotatably supported on a support shaft **65**, which passes through a small hole formed in the holder side wall member **2** from the inside (left side) and projects toward the outside (right side), by way of the bearings **66**, and a nut **68** is threadedly engaged with a threaded portion formed on an end portion of the support shaft **65** projecting from the bearing **66** by way of a washer **68w** so that the shift drum **67** is rotatably mounted on the holder side wall member **2**.

## 11

The engaging portion **58a** of the shift pin **58**, which projects from the slit **2** as formed in the guide sleeve portion **2a**, is slidably fitted into the shift guide groove **67v** formed on the shift drum **67**.

Accordingly, the rotation of the shift drum **67** moves the shift pin **58** fitted into the shift guide groove **67v** in the axial direction together with the control rod operator **55**.

The control rod operator **55** rotatably holds the right end portion of the control rod **51** and hence, the rotation of the shift drum **67** eventually moves the control rod **51** in the axial direction.

A first speed state shown in FIG. 2 and FIG. 3 is established when the control rod **51** is positioned at the leftmost side in the axial direction with respect to the counter gear shaft **12**. Each time the control rod **51** moves toward a right side in the axial direction sequentially from the first speed state, a neutral state, a second speed state, a third speed state, a fourth speed state, a fifth speed state, and a sixth speed state are established.

The control rod **51** moves on a hollow-shaft center axis **Z** of the counter gear shaft **12**, a left distal end portion **51e** of the control rod **51** faces and is insertable into an insertion hole **85h** formed in a bottomed cylindrical member **85**, which is press-fitted into an inner periphery of a left end portion of the counter gear shaft **12**, thus constituting a neutral position determining mechanism **80**, described later.

In a special constant-meshing-type multi-speed transmission of this embodiment, as described above, the shift drum **67** is provided in the vicinity of the counter gear shaft **12**, which is rotatably supported on an upper portion of the holder side wall member **2**.

In this manner, the power transmission between the shift drive mechanism **50** connects the shift drum **67** provided in the vicinity of the right end of the counter gear shaft **12** rotatably supported on the upper portion of the holder side wall member **2** and the shift spindle **102**, which is rotatably supported on the right engine case **1R** arranged below the holder side wall member **2**, which are relatively largely spaced apart from each other, is made by connecting them by the shift drive mechanism **50** on the holder side wall member **2**.

A proximal end of a shift arm **103** is fitted on a portion of the shift spindle **102**, which penetrates the right engine case **1R**. A long portion **103a** and a short portion **103b** extend from the proximal end of the shift arm **103**, an elongated hole **103ah** is formed in a distal end portion of the long portion **103a**, and a mounting hole **103bh** is formed in a distal end portion of the short portion **103b**. An engaging bolt **104** passes through the mounting hole **103bh**, and a nut **104n** is threadedly engaged with the engaging bolt **104** so that the engaging bolt **104** is fixedly mounted on the shift arm **103**.

A coil portion of a return coil spring **106** is wound around a right end of the shift arm **103**, and the removal of the return coil spring **106** is prevented by a cap member **105**.

On the other hand, a stopper pin **107** is fixedly mounted on the right engine case **1R** on a side of the short portion **103b**.

The return coil spring **106** is set such that both end portions extending from the coil portion sandwich the engaging bolt **104** and the stopper pin **107**, and the return coil spring **106** holds the shift arm **103** at a neutral position (see FIG. 5), and maintains the shift pedal at a neutral position by way of the shift spindle **102**.

Accordingly, when the shift spindle **102** is rotated due to a step-in operation or a loosening operation of the shift pedal by way of a link, the shift arm **103** is tilted integrally with the shift spindle **102** against the return coil spring **106** and hence, when an operating force of the shift pedal is released, the shift

## 12

arm **103** is returned to the neutral position together with the shift spindle **102** due to a biasing force of the return coil spring **106**.

An intermittent drive mechanism **100**, which intermittently rotates the shift drum **67** for every position of each gear speed by transmitting the reciprocating rotation of the shift spindle **102**, is arranged between the shift spindle **102** and the shift drum **67** (see FIG. 5).

As shown in FIG. 5, the intermittent drive mechanism **100** is arranged close to a rear side of a lower portion of the holder side wall member **2**.

The intermittent drive mechanism **100** is formed by combining an upstream-side rotary member **112** and a downstream-side rotary member **116** in a relatively rotatable manner, and is rotatably supported on the holder side wall member **2** by way of a bearing **119** (see FIG. 6).

A cylindrical collar **112ac** is mounted on a periphery of a projection **112a** formed on the upstream-side rotary member **112**, and the cylindrical collar **112ac** is slidably fitted in the elongated hole **103ah** formed in the distal end of the long portion **103a** of the shift arm **103**. The tilting of the shift arm **103** is transmitted as the rotation of the upstream-side rotary member **112** by way of the projection **112a**.

A flower-shaped cam portion **116b** is formed on an outer peripheral surface of a cylindrical portion of the downstream-side rotary member **116** in which a part of the upstream-side rotary member **112** is inserted, wherein the flower-shaped cam portion **116b** has a predetermined uneven cam surface **116bv** on which detent recessed portions corresponding to respective gear speeds consisting of the first speed, the neutral, the second speed, the third speed, the fourth speed, the fifth speed and the sixth speed are sequentially formed.

A downstream-member-side drive gear **117** is provided on an outer periphery of the downstream-side rotary member **116**, and a connecting rod portion **118** extends toward a side opposite to the upstream-side rotary member **112** (see FIG. 1, FIG. 6).

A left joining end portion **1181** of the connecting rod portion **118** is rotatably supported on the left engine case **1L** by way of a bearing **120**, and is joined to an operating shaft **121a** of a gear position sensor **121** mounted on the engine case **1L** (see FIG. 1).

A special pivotal shaft bolt **131**, which has threaded portions thereof formed on both sides of a center flange **131a**, is mounted on a lower portion of the holder side wall member **2** in a projecting manner toward the outside in a state where one threaded portion is threadedly engaged with the lower portion of the holder side wall member **2** (see FIG. 5, FIG. 6), a proximal end of a detent arm **132** of a detent mechanism **130** is rotatably supported on the projecting other threaded portion, a flanged collar **134** is fitted on the special pivotal shaft bolt **131**, a coil spring **135** is wound around the flanged collar **134**, the special pivotal shaft bolt **131** is inserted into the mounting hole formed in a long portion **125c** of a guide plate **125** which extends downward, and a nut **136** is threadedly engaged with the threaded portion of the special pivotal shaft bolt **131**, which further extends from the flanged collar **134** (see FIG. 7) thus fixing the long portion **125c** of the guide plate **125**, which extends downward and pivotally supporting the detent arm **132** of the detent mechanism **130** (see FIG. 6).

A roller **133** is rotatably and pivotally supported on a distal end of the detent arm **132** of the detent mechanism **130**, the coil spring **135**, which has one end thereof engaged with the fixed portion, has the other end thereof engaged with the detent arm **132** thus tiltably biasing the detent arm **132**, and the roller **133** mounted on the distal end of the detent arm **132** is pushed to the predetermined uneven cam surface **116bv** of

## 13

the flower-shaped cam portions **116b** of the downstream-side rotary member **116** where the detent recessed portions are sequentially formed thus constituting the detent mechanism **130**.

That is, in the detent mechanism **130**, by pushing the roller **133** to the uneven cam surface **116bv** of the flower-shaped cam portion **116b** of the downstream-side rotary member **116**, the roller **133** falls into the detent recessed portions corresponding to the respective gear speeds from the first speed, the neutral, the second speed, the third speed, the fourth speed, the fifth speed and the sixth speed so that the detent mechanism **130** can position and stably hold the downstream-side rotary member **116** at a rotary angle of desired gear speed.

The intermittent drive mechanism **100** has such a detent mechanism **130**.

An intermediate gear **140** is interposed between the downstream-member-side drive gear **117** of the downstream-side rotary member **116** and the drum-side driven gear **67g** of the shift drum **67**.

The intermediate gear **140** is formed in a bolt shape where a flattened head portion having an enlarged diameter is formed on an intermediate shaft portion **140a**, a teeth portion **140g** is formed on an outer periphery of the flattened head portion, and a threaded portion **140b** is formed on a distal end of the intermediate shaft portion **140a** (see FIG. 6).

To explain the structure in conjunction with FIG. 5 and FIG. 6, the intermediate gear **140** is inserted into a bearing portion of the holder side wall member **2** on a side closer to a front side between the downstream-member-side drive gear **117** and the drum-side driven gear **67g** arranged above the downstream-member-side drive gear **117** in a state where the intermediate gear **140** is inserted from the outside (right side), and two bearings **141, 141** are inserted into the bearing portion from the inside (left side). Hence, the intermediate gear **140** is rotatably supported on the bearing portion of the holder side wall member **2** by way of the bearings **141, 141**.

A C-shaped retainer **142** is inserted into the bearing portion from the inside (left side) and is engaged with a stepped portion formed on an inner peripheral surface of the bearing portion, thus preventing the removal of the bearings **141, 141**. A nut **143** is threadedly engaged with the threaded portion **140b** formed on the distal end of the intermediate shaft portion **140a** of the intermediate gear **140** by way of a washer, and inner races of the bearings **141, 141** are fastened by being sandwiched between the intermediate gear and the nut **143** thus rotatably mounting the intermediate gear **140**.

The teeth portion **140g** of the intermediate gear **140** is meshed with the downstream-member-side drive gear **117**, and also is meshed with the drum-side driven gear **67g** of the shift drum **67** and, hence, the rotation of the downstream-side rotary member **116** of the intermittent drive mechanism **100** is transmitted as the rotation of the shift drum **67** by way of the intermediate gear **140**.

The intermediate gear **140** is formed in a bolt shape where the flattened head portion having an enlarged diameter is formed on the intermediate shaft portion **140a**, and the intermediate shaft portion **140a** is rotatably supported by way of the bearings **141, 141** and, hence, the intermediate gear **140** can be arranged in a compact manner thus realizing the reduction in weight.

The intermittent drive mechanism **100** transmits power to the downstream-side rotary member **116** only during the outgoing rotation with respect to the reciprocating rotation of the upstream-side rotary member **112**, which is brought about by the reciprocating tilting of the shift arm **103** and, hence, the

## 14

downstream-side rotary member **116** is intermittently rotated every time the gear speed is changed over thus realizing the gear shift.

With respect to the shift pedal operation, the loosening operation is performed in the same manner as the step-in operation. Although the rotational directions of the shift arm **103**, the upstream-side rotary member **112** and the downstream-side rotary member **116** in the loosening operation become opposite to the corresponding rotational directions in the step-in operation, the downstream-side rotary member **116** is intermittently rotated, and the moving direction of the control rod **51** becomes opposite.

That is, when either one of the step-in shift pedal operation or the loosening shift pedal operation is performed, the shift spindle **102** is rotated so that the shift arm **103** is tilted integrally with the shift spindle **102**. The upstream-side rotary member **112** is rotated by way of the engagement between the elongated hole **103h** and the projection **112a**. The downstream-side rotary member **116**, which is rotated by way of the intermittent drive mechanism **100**, is held at a desired rotational position in a stable manner by the flower-shaped cam **116b** and the detent mechanism **130**. The rotation of the downstream-side rotary member **116** during such a period rotates the shift drum **67** by a predetermined amount by way of the intermediate gear **140** so that the control rod **51** moves in the axial direction by a predetermined amount by way of the shift pin **58** guided by the shift guide groove **67v**, thus changing over the gear speed.

The intermittent drive mechanism **100** includes the detent mechanism **130**, which positions and holds the flower-shaped cam **116b** at the predetermined rotational position together with the downstream-side rotary member **116** when the roller **133** is pushed and hence, the rotation of the shift spindle **102** can be intermittently transmitted to the shift drum **67** thus reliably positioning the shift drum **67** for every gear speed.

The gear position sensor **121** is arranged on the left engine case **1L** having a margin in space compared to the holder side wall member **2**, and the downstream-side rotary member **116**, which includes the flower-shaped cam **116b** of the detent mechanism **130** for determining the rotational position of the shift drum **67** by surely performing the intermittent driving, is connected to the gear position sensor **121** by way of the connecting rod portion **118**. Accordingly, the rotation of the downstream-side rotary member **116**, which is integrally provided with the flower-shaped cam **116b** operates the gear position sensor **121** by way of the connecting rod portion **118**, which is integrally joined to the downstream-side rotary member **116** and hence, the gear position can be properly and accurately detected.

As has been described above, the intermittent drive mechanism **100**, which intermittently transmits the rotation of the shift spindle **102** to the shift drum **67** for every gear speed, is arranged between the shift spindle **102** and the shift drum **67** and, hence, the shift spindle **102** and the shift drum **67** can be properly spaced apart from each other. Accordingly, the special constant-meshing-type multi-speed transmission **10** of this embodiment where the control rod **51** and the engaging means **20** are arranged in the inside of the counter gear shaft **12** and the shift drum **67** is arranged in the vicinity of the periphery of the counter gear shaft **12** can be easily applied to the left engine case **1L** corresponding to a transmission case of a constant-meshing-type multi-speed transmission of a general type where the counter gear shaft **12** on an upper side and the shift spindle **102** on a lower side are rotatably supported in a largely mutually spaced-apart manner.

The special constant-meshing-type multi speed transmission **10** of this embodiment can be applied to the transmission



case of the constant-meshing-type multi-speed transmission of a general type and hence, the transmission case can be used as it is without changing the constitution of a vehicle and thereby manufacturing cost can be largely decreased.

Further, the intermediate gear **140** is interposed between the downstream-member-side drive gear **117** and the drum-side driven gear **67g** and hence, the degree of freedom in positions where the downstream-side rotary member **116**, which is integrally formed with the downstream-member-side drive gear **117** and the intermittent drive mechanism **100**, are arranged is increased whereby the shift spindle **102** and the shift drum **67** can be more easily arranged also in the transmission case of a general type where the shift spindle **102** and the counter gear shaft **12** are rotatably supported in a relatively largely spaced-apart manner.

In the flower-shaped cam **116b** of the detent mechanism **130**, the predetermined uneven cam surface **116bv** on which the detent recessed portions corresponding to the respective gear speeds consisting of the first speed, the neutral, the second speed, the third speed, the fourth speed, the fifth speed and the sixth speed are sequentially formed is formed on the outer periphery of the flower-shaped cam **116b**, and the roller **133**, which is pushed toward the uneven cam surface **116bv**, falls in the detent recessed portions. Accordingly, the downstream-side rotary member **116** is positioned and is held in a stable manner together with the flower-shaped cam **116b**. However, to perform the smooth gear shift from the first speed to the second speed at the time of acceleration, the detent recessed portion corresponding to the neutral is shallower in depth than the detent recessed portions corresponding to other gear speeds and hence, a force for holding the downstream-side rotary member **116** in a stable manner is weak.

Accordingly, conventionally, when the gear speed is changed to the neutral by a shift pedal operation, to prevent the gear speed from being changed over to the second speed by skipping the neutral, it is necessary to stop the gear speed at the neutral by slightly loosening the shift pedal from the first speed. On the other hand, when the loosening operation is excessively large, there arises a possibility that the control rod **51** passes the neutral position and is moved to the second speed position.

Accordingly, in the multi speed transmission **10** of this embodiment, the neutral positioning mechanism **80**, which can surely position the control rod **51** at the neutral position, is mounted on the inner periphery of the left end portion of the counter gear shaft **12**.

To explain the structure in conjunction with FIG. 2, the bottomed cylindrical member **85** is press-fitted in the inner periphery of the left end portion of the counter gear shaft **12** from the left side, and is fixed at a predetermined position.

The insertion hole **85h** formed in the bottomed cylindrical member **85** is directed rightward and, from the left side of the counter gear shaft **12**, the bottomed cylindrical member **85** is press-fitted to a position approximately in the vicinity of a fitting position of the output sprocket **32** considerably in front of a supply fuel introducing hole **12x** formed in the counter gear shaft **12** in the axial direction.

An inner diameter of the insertion hole **85h** formed in the bottomed cylindrical member **85** is approximately equal to an outer diameter of the control rod **51** (also an outer diameter of the distal end portion **51e**), and the distal end portion **51e** of the control rod **51** faces and is insertable into the insertion hole **85h**.

Three guide holes **86** are formed in a peripheral wall of the bottomed cylindrical member **85** around the insertion hole

**85h** at equal intervals in the circumferential direction such that the guide holes **86** extend from the insertion hole **85h** in the oblique radial direction.

Three guide holes **86** are formed such that the guide holes **86** extend in the direction which makes an acute inclination angle with respect to the insertion direction of the control rod **51** into the insertion hole **85h**.

The guide hole **86** is formed by machining at a predetermined inclination angle from an outer peripheral side of the bottomed cylindrical member **85** by a drill such that a shape of a machined end is formed in a semispherical surface. Here, hole forming by the drill is stopped when a blade portion formed on a distal end of the drill, which obliquely cuts into the bottomed cylindrical member **85**, reaches the insertion hole **85h**, which is a stage just before the guide hole **86** completely reaches the insertion hole **85h** except for a portion of the blade portion. Accordingly, the inner diameter of the guide hole **86** is narrowed in the vicinity of the inner opening leading to the insertion hole **85h** so that a narrowed opening edge portion is formed. The inner diameter of the inner opening edge portion of the guide hole **86** is smaller than the inner diameter of the guide hole **86**, and also is smaller than an outer diameter of a ball **81** inserted into the guide hole **86**.

An outside opening of the guide hole **86** is closed by an inner peripheral surface of the counter gear shaft **12**.

The balls **81**, which respectively constitute engaging members, are movably inserted into these three guide holes **86**, respectively.

The ball **81** is a steel ball having a diameter slightly smaller than the inner diameter of the guide hole **86**, and is movable in the oblique radial direction by being guided by the guide hole **86**.

However, the diameter of the ball **81** is larger than the inner diameter of the opening edge portion of the guide hole **86** leading to the insertion hole **85h** and hence, the ball **81** cannot be removed into the insertion hole **85h** from the guide hole **86** by being restricted by the opening edge portion whereby the ball **81** is stopped in the guide hole **86** in a state where the ball **81** is fitted in the opening edge portion and a portion of the ball **81** projects into the insertion hole **85h** (see the ball **81** indicated by a double dashed chained line shown in FIG. 2).

With respect to three guide holes **86** formed in the bottomed cylindrical member **85**, which is rotatable about the horizontal center axis *Z* where three guide holes **86** are formed in the oblique radial direction from the insertion hole **85h**, at least one guide hole **86** is positioned above the insertion hole **85** and hence, when the rotation of the counter gear shaft **12** is stopped, at least one ball **81** moves toward the inside in the radial direction in the guide hole **86** due to a dead weight thereof and has a portion thereof projected into the insertion hole **85h**, while when the counter gear shaft **12** is being rotated, all three balls **81** move toward the outside in the radial direction in the guide holes **86** by a centrifugal force and hence, the balls **81** do not project into the insertion hole **85h**.

With respect to a left end portion of the control rod **51** inserted into the insertion hole **85h** formed in the bottomed cylindrical member **85**, an outer peripheral recessed groove **51v** having a narrow width is formed in front of a conically pointed distal end portion **51e** (see FIG. 2, FIG. 4).

To explain the structure in conjunction with FIG. 2, which shows the neutral positioning mechanism **80** in a first speed state, when the control rod **51** is positioned in a range from the first speed position on the leftmost side to the neutral position on a right side of the first speed position, the left end portion of the control rod **51** is inserted into the insertion hole **85h** formed in the bottomed cylindrical member **85** and hence, the

outer peripheral recessed groove **51v** formed on the control rod **51** faces the inner openings of the guide holes **86**.

When the neutral positioning mechanism **80** is in the first speed state shown in FIG. 2 and the vehicle is in a traveling state, the control rod **51** is at the first speed position where the control rod **51** moves to the leftmost side. In this case, the distal end portion **51e** of the control rod **51** and the outer peripheral recessed groove **51v** are inserted into the insertion hole **85h** formed in the bottomed cylindrical member **85**, and the inner openings **86i** of the guide holes **86** move to a position where the inner openings **86i** face a right side portion of the outer peripheral recessed groove **51v**, and all balls **81** (indicated by a solid line in FIG. 2), which are respectively inserted into three guide holes **86** formed in the bottomed cylindrical member **85**, which is rotated along with the rotation of the counter gear shaft **12**, move toward the outside in the radial direction by a centrifugal force and are brought into contact with the inner peripheral surface of the counter gear shaft **12** so that there are no balls **81** that project into the insertion hole **85h** from the inner openings **86i**.

When the gear speed is shifted up from the first speed traveling state to the second speed, although the control rod **51** moves rightward to the second speed position from the first speed position on the leftmost side through the neutral position, all balls **81** move toward the outside in the radial direction by a centrifugal force and do not project into the insertion hole **85h** from the inner openings **86i** and hence, there is no possibility that the balls **81** are engaged with the outer peripheral recessed groove **51v** formed on the control rod **51** whereby the control rod **51** smoothly moves to the second speed position from the first speed position through the neutral position thus executing the shift-up operation of the gear speed easily.

As described previously, also in the flower-shaped cam **116b** of the detent mechanism **130**, the recess of the detent recessed portion **116bv** corresponding to the neutral is shallow so that a stability holding force is weak whereby the control rod **51** easily passes the neutral.

Also when the gear speed is shifted down from the second speed to the first speed, the control rod **51** can move leftward smoothly without being obstructed by the balls **81**.

At the time of shifting up the gear speed to the higher gear speed from the second speed, the control rod **51** moves further rightward. Since the outer peripheral recessed groove **51v** formed on the control rod **51** including the distal end portion **51e** is removed from the insertion hole **85h** formed in the bottomed cylindrical member **85**, the shift-up operation is not influenced by the neutral positioning mechanism **80** including the shift-down operation.

In stopping the traveling of a vehicle, at a point of time that the rotation of the counter gear shaft **12** is stopped, the loosening operation of the shift pedal is performed at a level which is approximately one half of a usual gear shift operation so that the control rod **51** moves to the neutral position from the first speed position. On the other hand, when the rotation of the counter gear shaft **12** is stopped with the control rod **51** held at the first speed position, the ball **81** inserted into the guide hole **86** disposed above the insertion hole **85h** formed in the bottomed cylindrical member **85** moves toward the inside in the radial direction by a dead weight thereof, and projects into the outer peripheral recessed groove **51v** formed on the control rod **51** in a state that a portion of the ball **81** projects into the insertion hole **85h** from the inner opening.

Accordingly, when the control rod **51** moves rightward in such a state, a tapered left inner surface of the outer peripheral recessed groove **51v** formed on the control rod **51** is brought into contact with a portion of the ball **81** that advances into the

outer peripheral recessed groove **51v** and pushes the ball **81** to a right-side inclined surface of the guide hole **86** so that the ball **81** is sandwiched between the left inner surface and the right-side inclined surface whereby the control rod **51** is engaged with the ball **81**. Accordingly, the movement of the control rod **51** is restricted and hence, the control rod **51** can be easily and surely positioned at the neutral position.

As described previously, in the detent mechanism **130** of the intermittent drive mechanism **100**, a force for holding the positioning corresponding to the neutral in a stable manner is weak and hence, there exists a possibility that the gear speed skips the neutral. However, as described above, by stopping the traveling and by performing the loosening operation of the shift pedal at a level that is approximately one half of the usual shift operation, the movement of the control rod **51** is prevented at the neutral position so that the gear speed is surely positioned. Accordingly, it is unnecessary to delicately adjust the shift pedal operation for shifting the gear speed to the neutral and hence, the gear speed can be easily and surely shifted to the neutral.

It is possible to completely prevent the occurrence of a state where the loosening operation of the shift pedal is so large that the control rod **51** passes the neutral position and moves to the second speed position.

When the vehicle starts traveling by starting the internal combustion engine in a state where the control rod **51** is at the neutral position so that the vehicle is stopped, the ball **81**, which is inserted into the guide hole **86** arranged above the insertion hole **85h** formed in the bottomed cylindrical member **85**, advances into the outer peripheral recessed groove **51v** formed on the control rod **51**. However, the control rod **51** moves leftward and moves to the first speed position by the shift pedal operation and hence, there is no possibility that the ball **81** is engaged with the control rod **51** in a state where the ball **81** advances into and is held in the outer peripheral recessed groove **51v**. Accordingly, a gear shift can be performed by smoothly moving the control rod **51** to the first speed position from the neutral position.

After the gear shift is performed by moving the control rod **51** to the first speed position, the traveling of the vehicle can be started by connecting the friction clutch **5**.

When the counter gear shaft **12** is rotated by starting the traveling of the vehicle, all balls **81** move toward the outside in the radial direction in the guide holes **86** due to a centrifugal force so that the first speed traveling state shown in FIG. 2 is brought about.

The intermittent drive mechanism **100** of the shift drive mechanism **50** of the multi-speed transmission **10** according to this embodiment includes the shift arm **103**, which has the proximal end portion thereof fixedly mounted on the shift spindle **102** and is tilted integrally with the shift spindle **102** in a reciprocating manner, and the upstream-side rotary member **112** is rotated by way of the projection **112a** with which the elongated hole **103ah** formed in the tilting distal end portion of the shift arm **103** engages. Accordingly, an amount of rotation of the upstream-side rotary member **112** and an amount of rotation of the downstream-side rotary member **116** generated by the tilting of the shift arm **103** are determined so that an intermittent rotational amount of the shift drum **67** to which the rotation is transmitted from the downstream-side rotary member **116** by way of a gear system can be properly determined.

In the shift drive mechanism **50** of the multi-speed transmission **10** according to this embodiment, the shift drum **67** is rotatably supported on the holder side wall member **2**, which is detachably mounted on the right transmission case **1R** and forms a body separate from the right transmission case **1R**,

and the upstream-side rotary member **112** and the downstream-side rotary member **116** are coaxially and rotatably supported. Accordingly, a unit is formed by incorporating the shift drum **67** and the intermittent drive mechanism **100** into the holder side wall member **2** so that these parts can be handled integrally, thus enhancing assembling property.

The gear train constituted of the downstream-member-side drive gear **117**, the intermediate gear **140** and the drum-side driven gear **67g** is arranged along the outer surface of the holder side wall member **2**, the flower-shaped cam **116b** is arranged outside the downstream-member-side drive gear **117**, and the roller **133**, which is pushed toward the uneven cam surface **116bv** of the flower-shaped cam **116b**, is positioned outside and overlaps with the intermediate gear **140**. Accordingly, the shift drive mechanism **50** can be constituted in a compact manner.

#### DESCRIPTION OF REFERENCE NUMERALS AND SIGNS

m: drive shift gear, m1 to m6: first to sixth drive shift gears,  
n: driven shift gear, n1 to n6: first to sixth driven shift gears,  
**1**: engine case (transmission case), **1L**: left engine case (left transmission case), **1R**: right engine case (right transmission case), **2**: holder side wall member,  
**10**: multi-speed transmission, **11**: main gear shaft, **12**: counter gear shaft,  
**20**: engaging means, C: cam rod, R: tilting pawl member, Rp: engaging pawl portion,  
**50**: shift drive mechanism, **51**: control rod, **51e**: distal end portion, **51v**: outer peripheral recessed groove, **51a**, **51b**: outer peripheral recessed portion, **52**, **53**: lost motion mechanism, **55**: control rod operator, **58**: shift pin, **67**: shift drum, **67g**: drum-side driven gear, **67v**: shift guide groove, **80**: neutral positioning mechanism, **81**: ball, **85**: bottomed cylindrical member, **85h**: insertion hole, **86**: guide hole, **102**: shift spindle, **103**: shift arm, **106**: return coil spring, **100**: intermittent drive mechanism  
**112**: upstream-side rotary member, **112a**: projection, **116**: downstream-side rotary member, **116b**: flower-shaped cam portion, **116bv**: uneven cam surface, **117**: downstream-member-side drive gear, **118**: connecting rod portion, **121**: gear position sensor, **125**: guide plate,  
**130**: detent mechanism, **132**: detent arm, **133**: roller,  
**140**: intermediate gear

What is claimed is:

**1.** A shift drive mechanism of a multi-speed transmission where the transmission is configured such that

a group of gears formed of a plurality of drive gears and a group of gears formed of a plurality of driven gears are rotatably supported on gear shafts arranged parallel to each other respectively in such a state where the drive gears and the driven gears are meshed with each other for every gear speed,

one group of gears formed of the plurality of gears out of the group of gears formed of the plurality of drive gears and the group of gears formed of the plurality of driven gears is fixed to one gear shaft, and an engagement changeover mechanism, which changes over the engagement between the other gear shaft and the respective gears for every gear, is provided between the other group of gears formed of the plurality of gears and the other gear shaft, and

a control rod is movable in the axial direction on a hollow-shaft center axis of the other gear shaft formed in a

hollow shape so that the engagement changeover mechanism is driven whereby a gear shift is performed, and

a shift pin, which is engaged with a shift guide groove formed on an outer periphery of a shift drum arranged in the vicinity of a periphery of the other gear shaft and is guided due to the rotation of the shift drum, moves the control rod in the axial direction, wherein

an intermittent drive mechanism, which intermittently rotates the shift drum for every position of each gear speed by transmitting the reciprocating rotation of a shift spindle, which is connected to a gear shift operating member, is arranged between the shift spindle and the shift drum,

wherein the shift drive mechanism includes a shift arm, which has a proximal end portion thereof fixedly mounted on the shift spindle and is tilted integrally with the shift spindle in a reciprocating manner, and a tilting distal end portion of the shift arm rotates an upstream-side rotary member.

**2.** The shift drive mechanism of a multi-speed transmission according to claim **1**, wherein the intermittent drive mechanism, which transmits power only during the outgoing rotation to a downstream-side rotary member with respect to the reciprocating rotation of the upstream-side rotary member, is provided between the shift spindle and the shift drum, and

the rotation of a downstream-member-side drive gear, which is formed integrally with the downstream-side rotary member, is transmitted to a drum-side driven gear, which is integrally formed on the shift drum due to the meshing of the gears.

**3.** The shift drive mechanism of a multi-speed transmission according to claim **2**, wherein the intermittent drive mechanism includes a detent mechanism where a flower-shaped cam is coaxially and integrally formed with the downstream-side rotary member, and the flower-shaped cam is positioned and held at the predetermined rotational position together with the downstream-side rotary member by pushing a roller by a biasing device toward a predetermined uneven cam surface of the flower-shaped cam where a plurality of detent recessed portions are sequentially formed on the uneven cam surface in a circumferential direction.

**4.** The shift drive mechanism of a multi-speed transmission according to claim **3**, wherein an intermediate gear is interposed between the downstream-member-side drive gear and the drum-side driven gear.

**5.** The shift drive mechanism of a multi-speed transmission according to claim **4**, wherein

the multi-speed transmission is housed in a transmission case, and

the shift drum is rotatably supported on a holder side wall member, which is detachably mounted on the transmission case and forms a body separate from the transmission case, and the upstream-side rotary member and the downstream-side rotary member are coaxially and rotatably supported.

**6.** The shift drive mechanism of a multi-speed transmission according to claim **5**, wherein a connecting rod portion, which extends on a rotation center axis from the downstream-side rotary member rotatably supported on the holder side wall member, is coaxially joined to an operating shaft of a gear position sensor mounted on the transmission case.

**7.** The shift drive mechanism of a multi-speed transmission according to claim **5**, wherein the intermediate gear is formed in a bolt shape where a head portion having an enlarged

21

diameter is formed on an intermediate shaft portion, and a teeth portion is formed on an outer periphery of the head portion, and

the intermediate shaft portion is rotatably supported on the holder side wall member via a bearing.

8. The shift drive mechanism of a multi-speed transmission according to claim 7, wherein a gear train where the downstream-member-side drive gear, the intermediate gear and the drum-side driven gear are meshed with each other sequentially is arranged along an outer surface of the holder side wall member,

the flower-shaped cam is arranged outside the downstream-member-side drive gear in the axial direction, and

the roller, which is pushed toward the uneven cam surface of the flower-shaped cam by the biasing device, overlaps with the intermediate gear as viewed in the axial direction.

9. The shift drive mechanism of a multi-speed transmission according to claim 1, wherein

the multi-speed transmission is housed in a transmission case, and

the shift drum is rotatably supported on a holder side wall member, which is detachably mounted on the transmission case and forms a body separate from the transmission case, and the upstream-side rotary member and a downstream-side rotary member are coaxially and rotatably supported.

10. The shift drive mechanism of a multi-speed transmission according to claim 9, wherein a connecting rod portion, which extends on a rotation center axis from the downstream-side rotary member rotatably supported on the holder side wall member is coaxially joined to an operating shaft of a gear position sensor mounted on the transmission case.

11. The shift drive mechanism of a multi-speed transmission according to claim 9, wherein an intermediate gear interposed between a downstream-member-side drive gear and a drum-side driven gear is formed in a bolt shape where a head portion having an enlarged diameter is formed on an intermediate shaft portion, and a teeth portion is formed on an outer periphery of the head portion, and

the intermediate shaft portion is rotatably supported on the holder side wall member via a bearing.

12. The shift drive mechanism of a multi-speed transmission according to claim 11, wherein a gear train where the downstream-member-side drive gear, the intermediate gear and the drum-side driven gear are meshed with each other sequentially is arranged along an outer surface of the holder side wall member,

a flower-shaped cam of a detent mechanism of the intermittent drive mechanism is arranged outside the downstream-member-side drive gear in the axial direction, and

22

a roller, which is pushed toward the uneven cam surface of the flower-shaped cam by a biasing device, overlaps with the intermediate gear as viewed in the axial direction.

13. The shift drive mechanism of a multi-speed transmission according to claim 10, wherein an intermediate gear interposed between a downstream-member-side drive gear and a drum-side driven gear is formed in a bolt shape where a head portion having an enlarged diameter is formed on an intermediate shaft portion, and a teeth portion is formed on an outer periphery of the head portion, and

the intermediate shaft portion is rotatably supported on the holder side wall member via a bearing.

14. The shift drive mechanism of a multi-speed transmission according to claim 13, wherein a gear train where the downstream-member-side drive gear, the intermediate gear and the drum-side driven gear are meshed with each other sequentially is arranged along an outer surface of the holder side wall member,

a flower-shaped cam of a detent mechanism of the intermittent drive mechanism is arranged outside the downstream-member-side drive gear in the axial direction, and

a roller, which is pushed toward the uneven cam surface of the flower-shaped cam by a biasing device, overlaps with the intermediate gear as viewed in the axial direction.

15. The shift drive mechanism of a multi-speed transmission according to claim 6, wherein the intermediate gear is formed in a bolt shape where a head portion having an enlarged diameter is formed on an intermediate shaft portion, and a teeth portion is formed on an outer periphery of the head portion, and

the intermediate shaft portion is rotatably supported on the holder side wall member via a bearing.

16. The shift drive mechanism of a multi-speed transmission according to claim 15, wherein a gear train where the downstream-member-side drive gear, the intermediate gear and the drum-side driven gear are meshed with each other sequentially is arranged along an outer surface of the holder side wall member,

the flower-shaped cam is arranged outside the downstream-member-side drive gear in the axial direction, and

the roller, which is pushed toward the uneven cam surface of the flower-shaped cam by the biasing device, overlaps with the intermediate gear as viewed in the axial direction.

\* \* \* \* \*