

US009220318B2

(12) **United States Patent**  
**James et al.**

(10) **Patent No.:** **US 9,220,318 B2**  
(45) **Date of Patent:** **Dec. 29, 2015**

(54) **ARTICLE OF FOOTWEAR WITH ADJUSTABLE FITTING SYSTEM**

(56) **References Cited**

(71) Applicant: **NIKE, Inc.**, Beaverton, OR (US)

(72) Inventors: **Dervin A. James**, Hillsboro, OR (US);  
**Zachary M. Elder**, Portland, OR (US);  
**Elizabeth A. Kilgore**, Portland, OR (US)

(73) Assignee: **NIKE, Inc.**, Beaverton, OR (US)

(\*) Notice: Subject to any disclaimer, the term of this patent is extended or adjusted under 35 U.S.C. 154(b) by 134 days.

(21) Appl. No.: **14/039,225**

(22) Filed: **Sep. 27, 2013**

(65) **Prior Publication Data**

US 2015/0089839 A1 Apr. 2, 2015

(51) **Int. Cl.**  
**A43B 11/00** (2006.01)  
**A43C 11/00** (2006.01)  
(Continued)

(52) **U.S. Cl.**  
CPC ..... **A43C 11/002** (2013.01); **A43B 5/04** (2013.01); **A43B 11/00** (2013.01); **A43B 13/18** (2013.01); **A43C 11/004** (2013.01); **A43C 11/006** (2013.01)

(58) **Field of Classification Search**  
CPC ..... **A43B 13/141**; **A43B 13/122**; **A43B 5/02**; **A43B 5/0421**; **A43B 5/005**; **A43B 3/26**; **A43B 3/06**; **A43B 3/0057**; **A43C 1/04**; **A43C 1/06**; **A43C 1/00**; **A43C 11/00**; **A43C 11/08**; **A43C 11/002**; **A43C 11/12**; **A43C 11/18**; **A43C 11/165**  
USPC ..... **36/91**, **88**, **141**, **43**, **50.5**, **32 A**, **23**, **3 A**, **36/54**, **114**, **97**, **117.7**, **101**, **50.1**, **102**, **36/118.01**

See application file for complete search history.

U.S. PATENT DOCUMENTS

2,072,785 A \* 3/1937 Wulff ..... 36/11.5  
2,084,671 A \* 6/1937 Curran ..... 36/7.6

(Continued)

FOREIGN PATENT DOCUMENTS

CN 202335387 7/2012  
DE 1084173 6/1960

(Continued)

OTHER PUBLICATIONS

1 Hour Cycling Shoe, Industrial Designer Benjamin R. Lloyd, <http://benjaminrloyd.com/industrialdesign/1-hour-cycling-shoe>, 3pp, accessed Mar. 25, 2013.

(Continued)

*Primary Examiner* — Shaun R Hurley  
*Assistant Examiner* — Bao-Thieu L Nguyen

(74) *Attorney, Agent, or Firm* — Honigman Miller Schwartz and Cohn LLP; Matthew H. Szalach; Jonathan P. O'Brien

(57) **ABSTRACT**

An article of footwear includes a fitting system with an upper member that is supported by the upper and a strand guide that is supported by the sole structure. The strand guide is flexible and flexes in concert with the sole structure. The strand guide has a guide surface. The fitting system further includes a tensioning system with a flexible strand that is configured to bias the upper member toward the strand guide. The flexible strand has a first section coupled to the upper member and a second section extending through the sole structure. The second section abuts the guide surface. The second section is configured to slide across the guide surface as a result of flexure of the strand guide. The first section and the upper member are configured to move relative to the sole structure as a result of sliding of the second section across the guide surface.

**31 Claims, 15 Drawing Sheets**

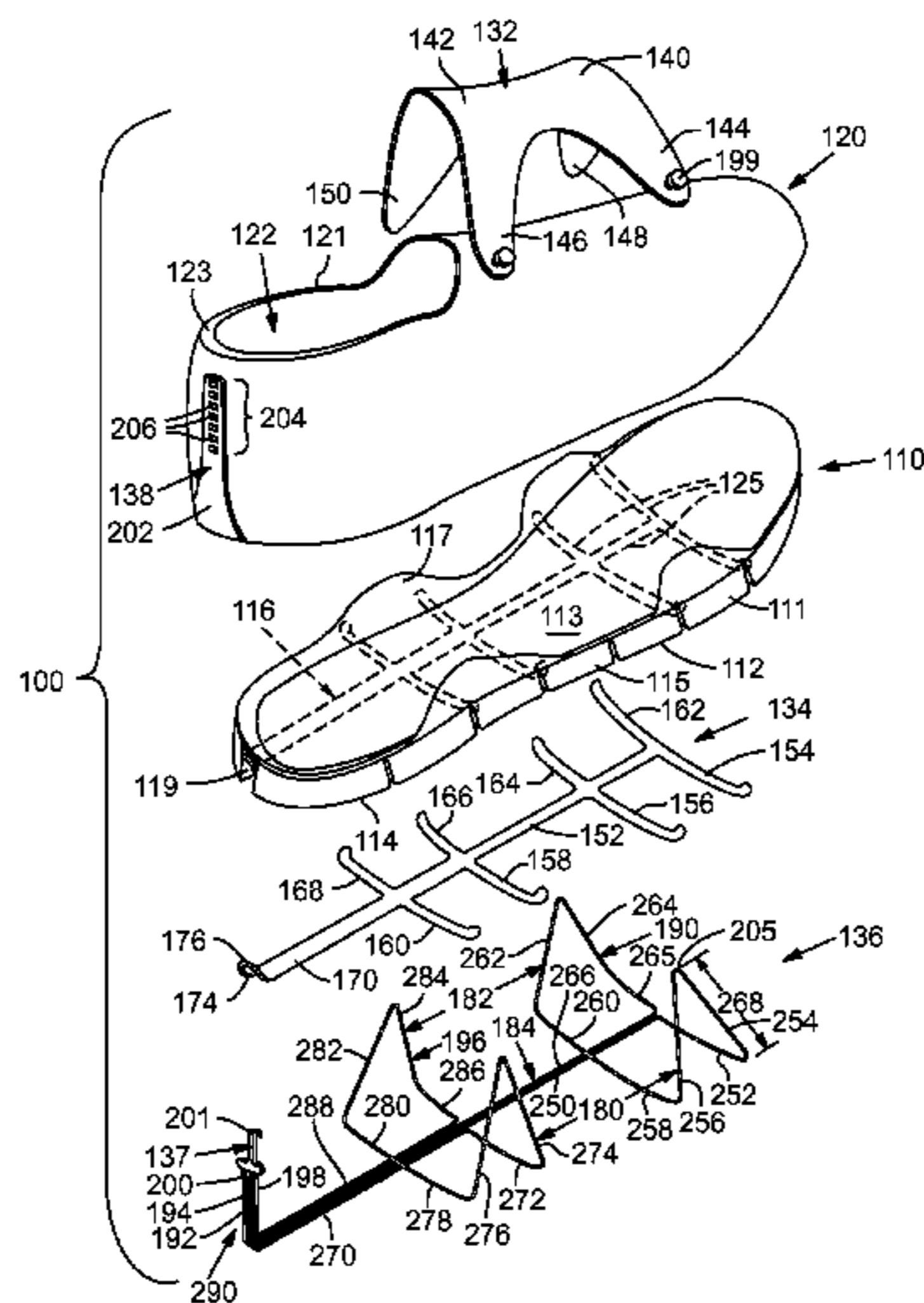

- (51) **Int. Cl.**  
*A43B 13/18* (2006.01)  
*A43B 5/04* (2006.01)

(56) **References Cited**

U.S. PATENT DOCUMENTS

2,088,851 A \* 8/1937 Gantenbein ..... 36/50.1  
 2,143,556 A \* 1/1939 Hodaly ..... 36/45  
 2,147,197 A 2/1939 Glidden  
 2,314,098 A 3/1943 McDonald  
 2,343,390 A 3/1944 Ushakoff  
 2,440,393 A 4/1948 Clark  
 2,495,984 A 1/1950 Roy  
 2,569,764 A 10/1951 Jonas  
 2,608,078 A 8/1952 Anderson  
 2,641,004 A 6/1953 Whiting et al.  
 3,583,081 A 6/1971 Hayashi  
 3,703,775 A \* 11/1972 Gatti ..... 36/128  
 3,793,749 A \* 2/1974 Gertsch et al. .... 36/117.6  
 4,447,967 A 5/1984 Zaino  
 4,513,520 A \* 4/1985 Koch ..... 36/117.8  
 4,592,154 A 6/1986 Oatman  
 4,654,985 A \* 4/1987 Chalmers ..... 36/118.2  
 4,750,339 A 6/1988 Simpson et al.  
 4,756,098 A 7/1988 Boggia  
 4,785,558 A 11/1988 Shiomura  
 4,811,503 A \* 3/1989 Iwama ..... 36/118.1  
 4,813,158 A 3/1989 Brown  
 5,003,711 A 4/1991 Nerrinck et al.  
 5,291,671 A 3/1994 Caberlotto et al.  
 5,345,638 A 9/1994 Nishida  
 5,371,957 A 12/1994 Gaudio  
 5,381,609 A \* 1/1995 Hieblinger ..... 36/50.1  
 5,463,822 A \* 11/1995 Miller ..... 36/50.1  
 5,678,329 A 10/1997 Griffin et al.  
 5,692,319 A 12/1997 Parker et al.  
 5,755,044 A \* 5/1998 Veylupek ..... 36/50.1  
 5,791,021 A 8/1998 James  
 6,032,387 A \* 3/2000 Johnson ..... 36/50.1  
 6,052,921 A \* 4/2000 Oreck ..... 36/50.1  
 6,286,233 B1 \* 9/2001 Gaither ..... 36/50.1  
 6,333,105 B1 12/2001 Tanaka et al.  
 D456,121 S \* 4/2002 Smith, III ..... D2/901  
 6,378,230 B1 \* 4/2002 Rotem et al. .... 36/50.1  
 6,467,194 B1 \* 10/2002 Johnson ..... 36/50.1  
 D472,041 S 3/2003 Kuerbis  
 6,598,322 B2 7/2003 Jacques et al.  
 6,772,541 B1 8/2004 Ritter  
 7,065,906 B2 \* 6/2006 Jones et al. .... 36/50.1  
 7,134,224 B2 \* 11/2006 Elkington et al. .... 36/50.1  
 D553,842 S 10/2007 Paz  
 7,343,701 B2 3/2008 Pare et al.  
 7,392,990 B2 \* 7/2008 Bussiere ..... 280/11.18  
 7,562,470 B2 7/2009 Keen  
 7,568,298 B2 8/2009 Kerns  
 7,685,740 B2 \* 3/2010 Sokolowski ..... 36/8.3  
 7,793,435 B1 9/2010 Ruth  
 7,818,899 B2 \* 10/2010 Dinndorf et al. .... 36/88  
 7,975,403 B2 \* 7/2011 Mosher ..... 36/51  
 8,001,704 B2 \* 8/2011 Baudouin ..... 36/102  
 8,006,410 B2 8/2011 Romboli et al.  
 8,037,621 B2 \* 10/2011 Hooper ..... 36/3 A  
 8,074,379 B2 \* 12/2011 Robinson et al. .... 36/50.1  
 D651,380 S 1/2012 Wilcots  
 8,151,490 B2 4/2012 Sokolowski  
 8,230,618 B2 7/2012 Bruce et al.  
 8,387,282 B2 \* 3/2013 Baker et al. .... 36/50.1  
 8,424,225 B2 \* 4/2013 Hazenberg et al. .... 36/102  
 8,707,587 B2 \* 4/2014 Christensen et al. .... 36/102  
 2002/0148258 A1 10/2002 Cole et al.  
 2004/0181975 A1 \* 9/2004 Piva ..... 36/117.1  
 2004/0226190 A1 \* 11/2004 Elkington et al. .... 36/50.5  
 2005/0120593 A1 \* 6/2005 Mason ..... 36/107  
 2005/0284000 A1 12/2005 Kerns

2006/0000116 A1 \* 1/2006 Brewer ..... 36/50.1  
 2006/0048413 A1 3/2006 Sokolowski et al.  
 2006/0117607 A1 \* 6/2006 Pare et al. .... 36/50.1  
 2007/0011910 A1 \* 1/2007 Keen ..... 36/50.1  
 2007/0266598 A1 \* 11/2007 Pawlus et al. .... 36/102  
 2008/0110049 A1 5/2008 Sokolowski et al.  
 2008/0216355 A1 \* 9/2008 Becker et al. .... 36/102  
 2009/0126231 A1 5/2009 Malmivaara  
 2010/0077634 A1 4/2010 Bell  
 2010/0146818 A1 \* 6/2010 Sokolowski ..... 36/102  
 2010/0154256 A1 6/2010 Dua  
 2010/0319216 A1 \* 12/2010 Grenzke et al. .... 36/54  
 2011/0126428 A1 \* 6/2011 Hazenberg et al. .... 36/103  
 2011/0197475 A1 8/2011 Weidl et al.  
 2011/0258876 A1 \* 10/2011 Baker et al. .... 36/50.1  
 2012/0023686 A1 2/2012 Huffa et al.  
 2012/0131818 A1 5/2012 Nishiwaki et al.  
 2012/0233882 A1 9/2012 Huffa et al.  
 2012/0240428 A1 \* 9/2012 Knoll ..... 36/50.1  
 2012/0255201 A1 10/2012 Little  
 2012/0260526 A1 10/2012 Smith et al.  
 2013/0212905 A1 \* 8/2013 Hazenberg et al. .... 36/28  
 2014/0101972 A1 \* 4/2014 Ha ..... 36/102  
 2014/0130372 A1 \* 5/2014 Aveni et al. .... 36/83  
 2014/0223778 A1 \* 8/2014 Horacek ..... 36/102  
 2014/0223779 A1 \* 8/2014 Elder et al. .... 36/103

FOREIGN PATENT DOCUMENTS

DE	19738433	4/1998
DE	19728848	1/1999
EP	0448714	10/1991
EP	0728860	8/1996
EP	0758693	2/1997
EP	1233091	8/2002
FR	2171172	9/1973
FR	2697727	10/1993
GB	538365	8/1941
GB	1603487	11/1981
JP	H06113905	4/1994
JP	H08109553	4/1996
JP	09065908	3/1997
JP	H11302943	11/1999
JP	2007190351	8/2007
NL	7304678	10/1974
WO	9003744	4/1990
WO	0032861	6/2000
WO	0231247	4/2002

OTHER PUBLICATIONS

Crocheted Slippers Gladiator Home sandals, <http://etsy.com/listing/5079558>, 2pp, accessed Mar. 25, 2013.  
 Dior concepts, Byron Jeffrey, <http://www.byronjeffrey.com/55336/881326/portfolio/dior>, 4pp, accessed Mar. 25, 2013.  
 RCD-Online—Design consultation service, Design No. 000014915-0006. Designed by Dave J. Schenone, 3pp.  
 Declaration of Dr. Edward C. Frederick from the US Patent and Trademark Office inter Partes Review of U.S. Pat. No. 7,347,011 (178pp).  
 David J. Spencer, Knitting Technology: A Comprehensive Handbook and Practical Guide (Third ed., Woodhead Publishing Ltd. 2001) (413pp).  
 Excerpt of Hannelore Eberle et al., Clothing Technology (Third English ed., Beuth-Verlag GmH 2002) (book cover and back; pp. 2-3, 83).  
 International Search Report and Written Opinion in connection with International Application No. PCT/US2014/019542, mailed Jun. 26, 2014.  
 International Search Report and Written Opinion in connection with International Application No. PCT/US2014/019548, mailed Jun. 26, 2014.

\* cited by examiner

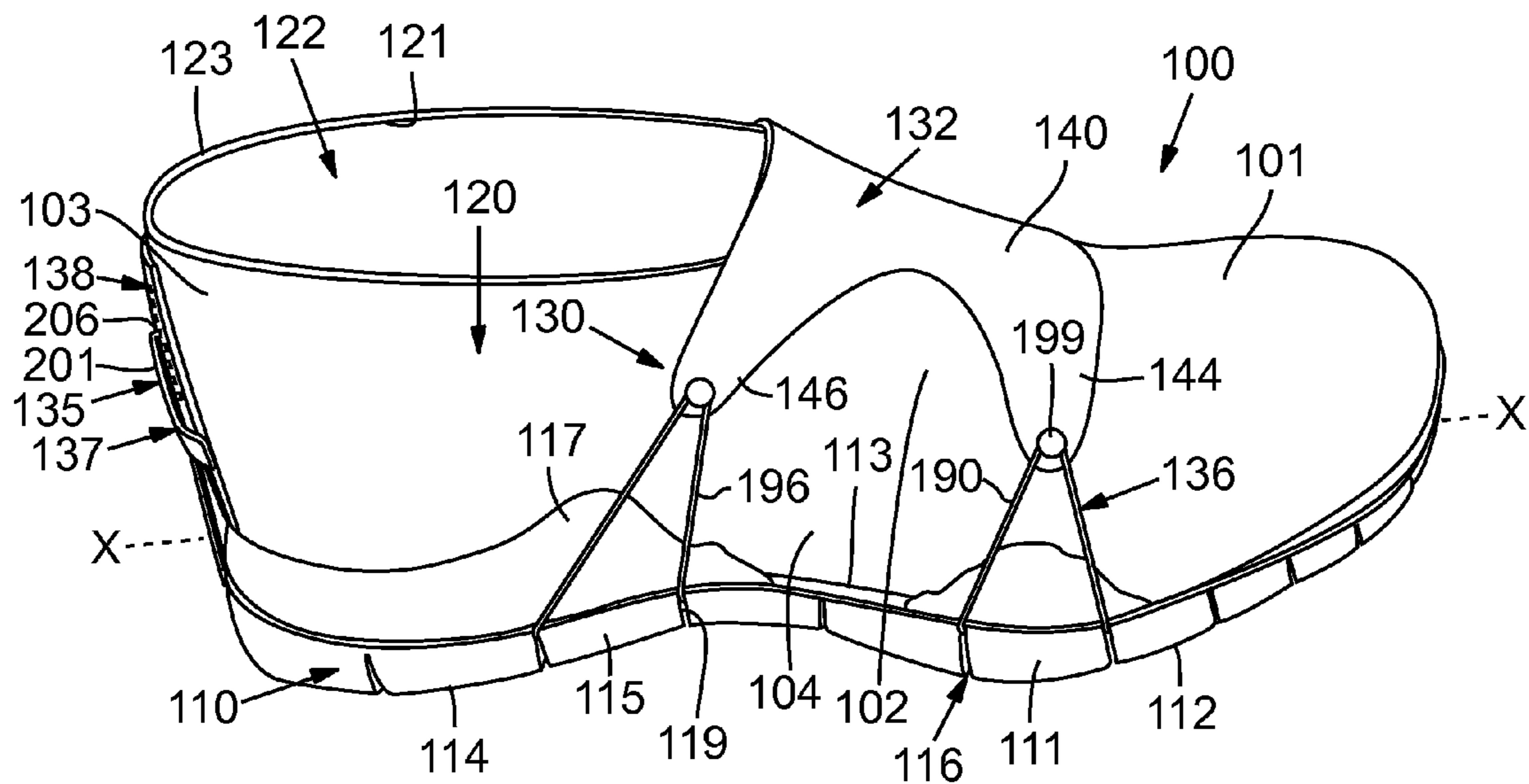

FIG. 1

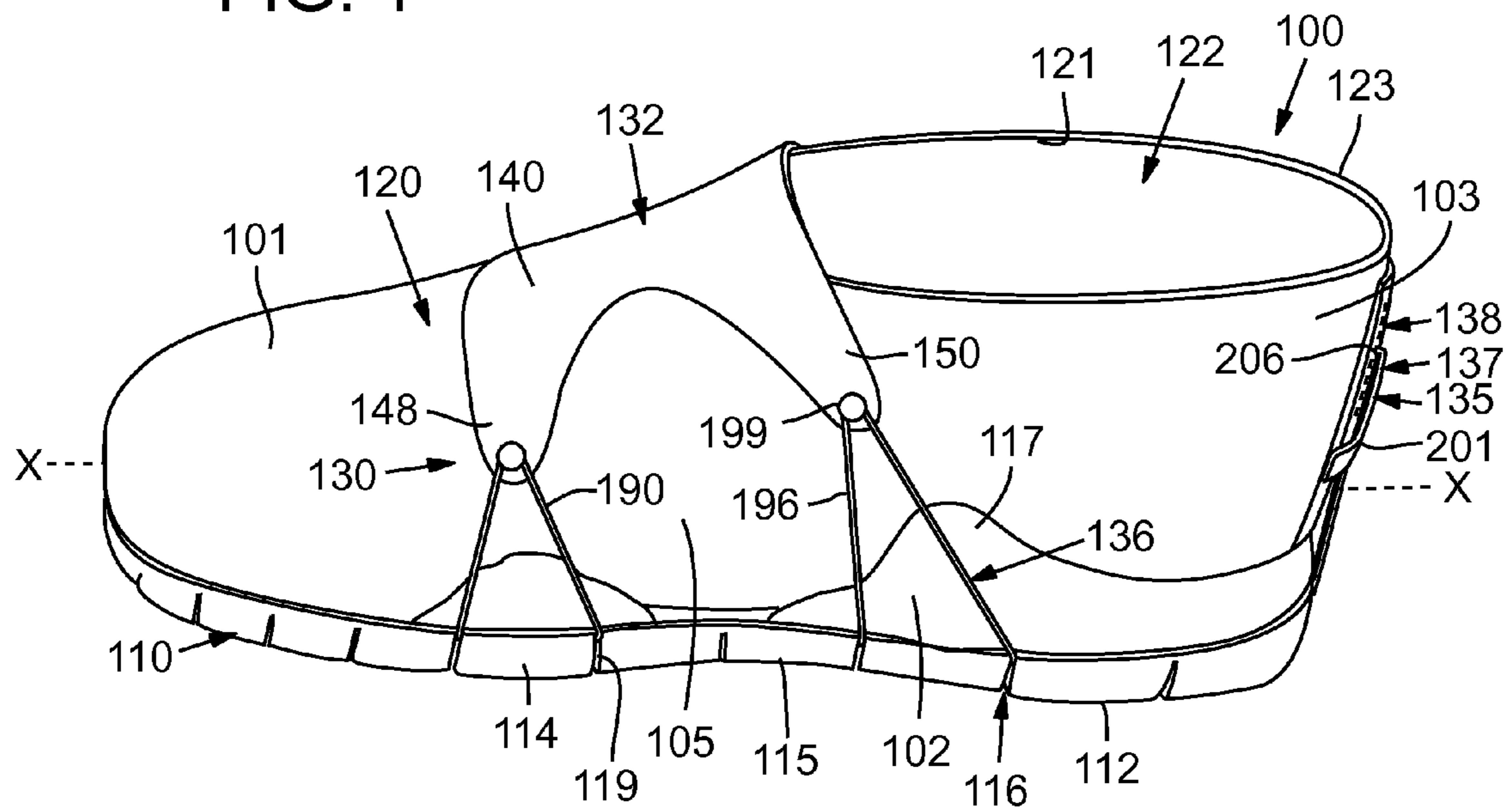

FIG. 2

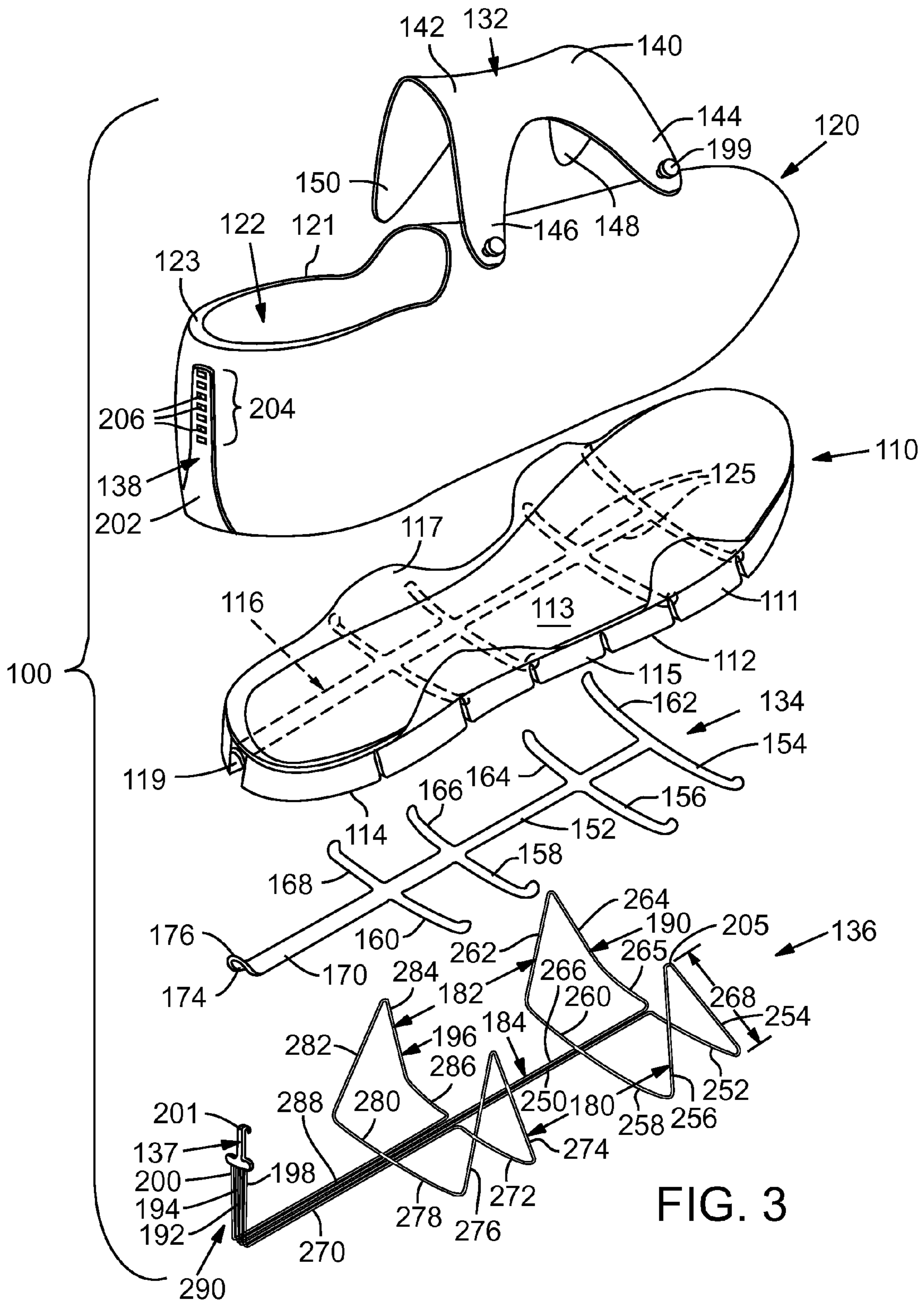

FIG. 3

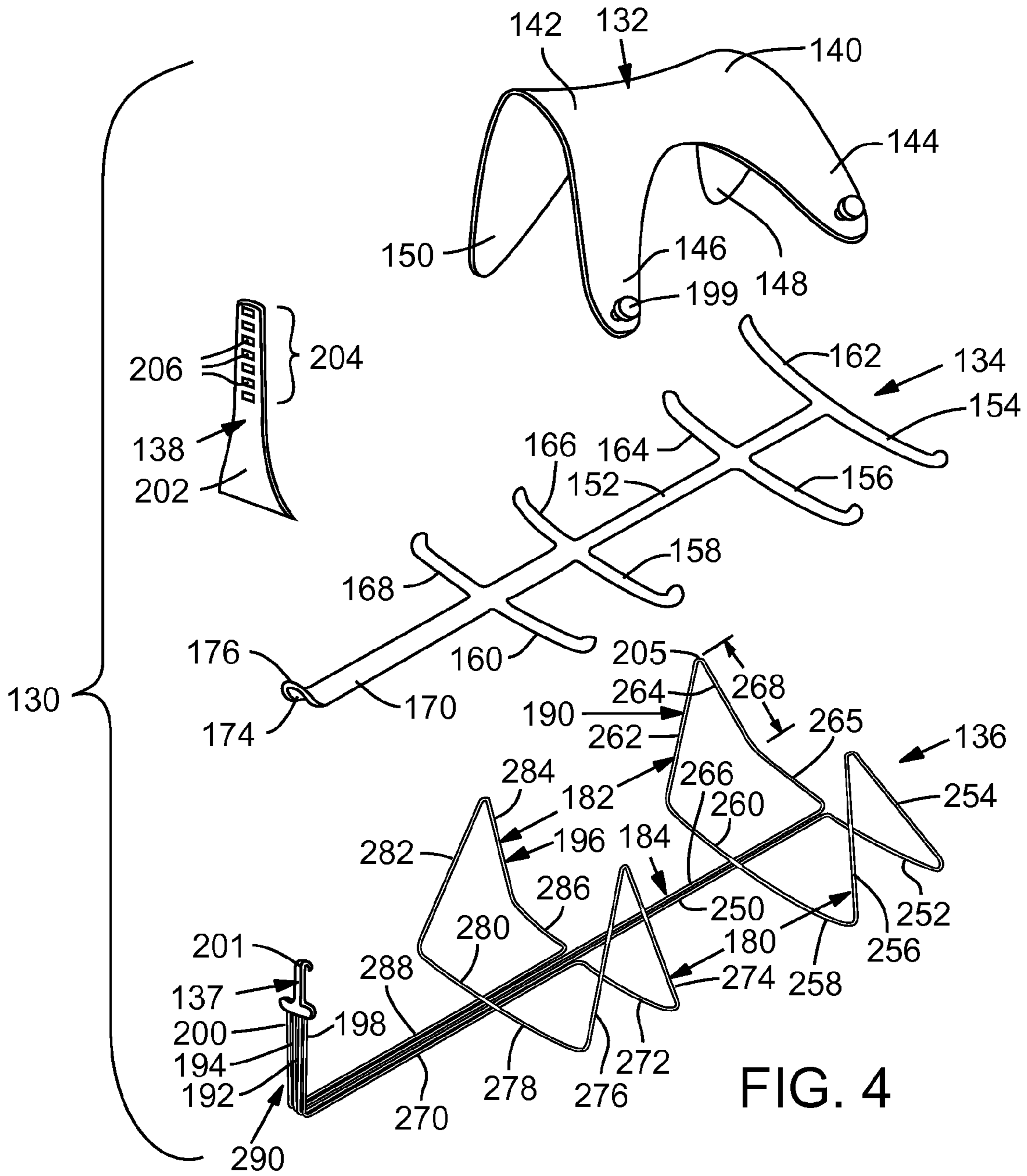

FIG. 4

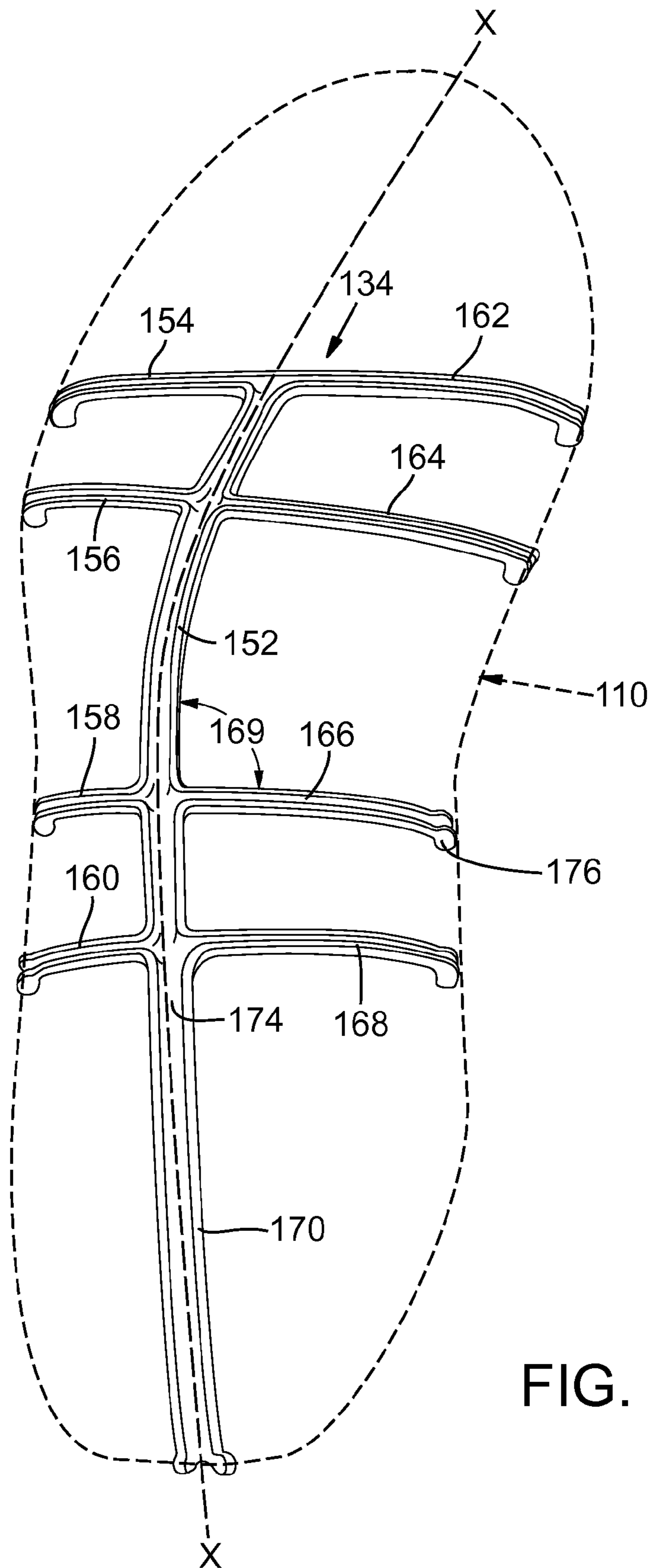

FIG. 5

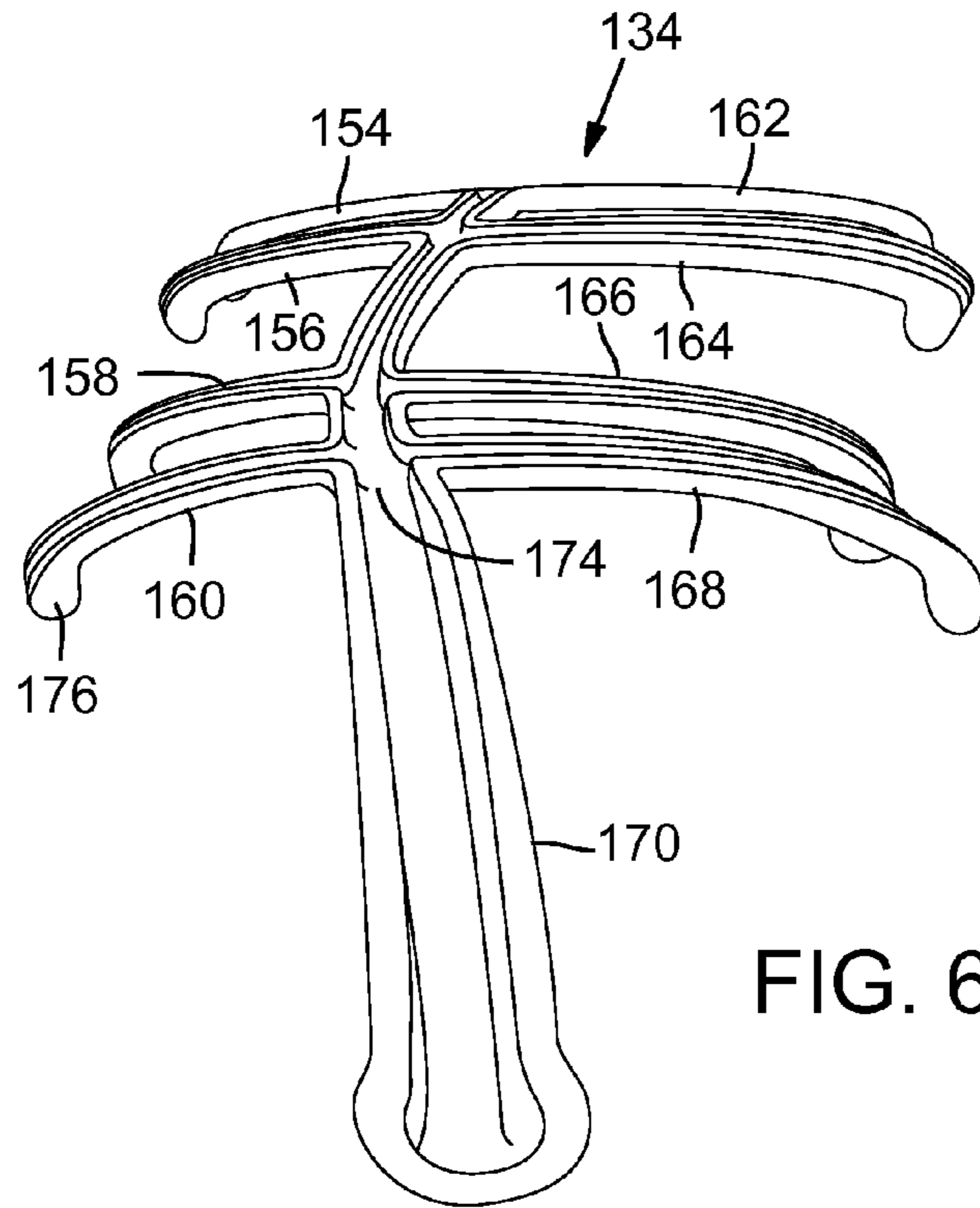

FIG. 6

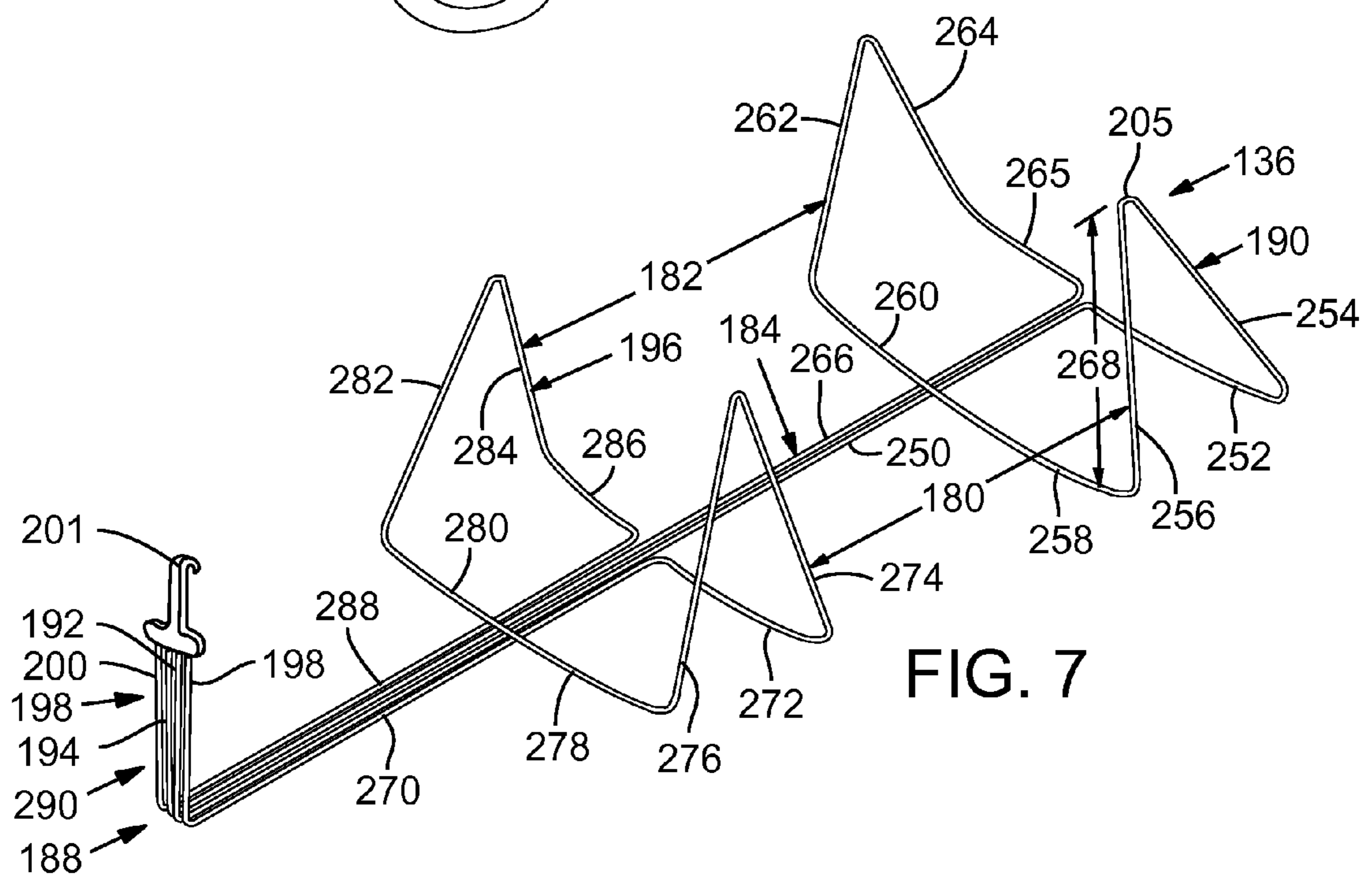

FIG. 7

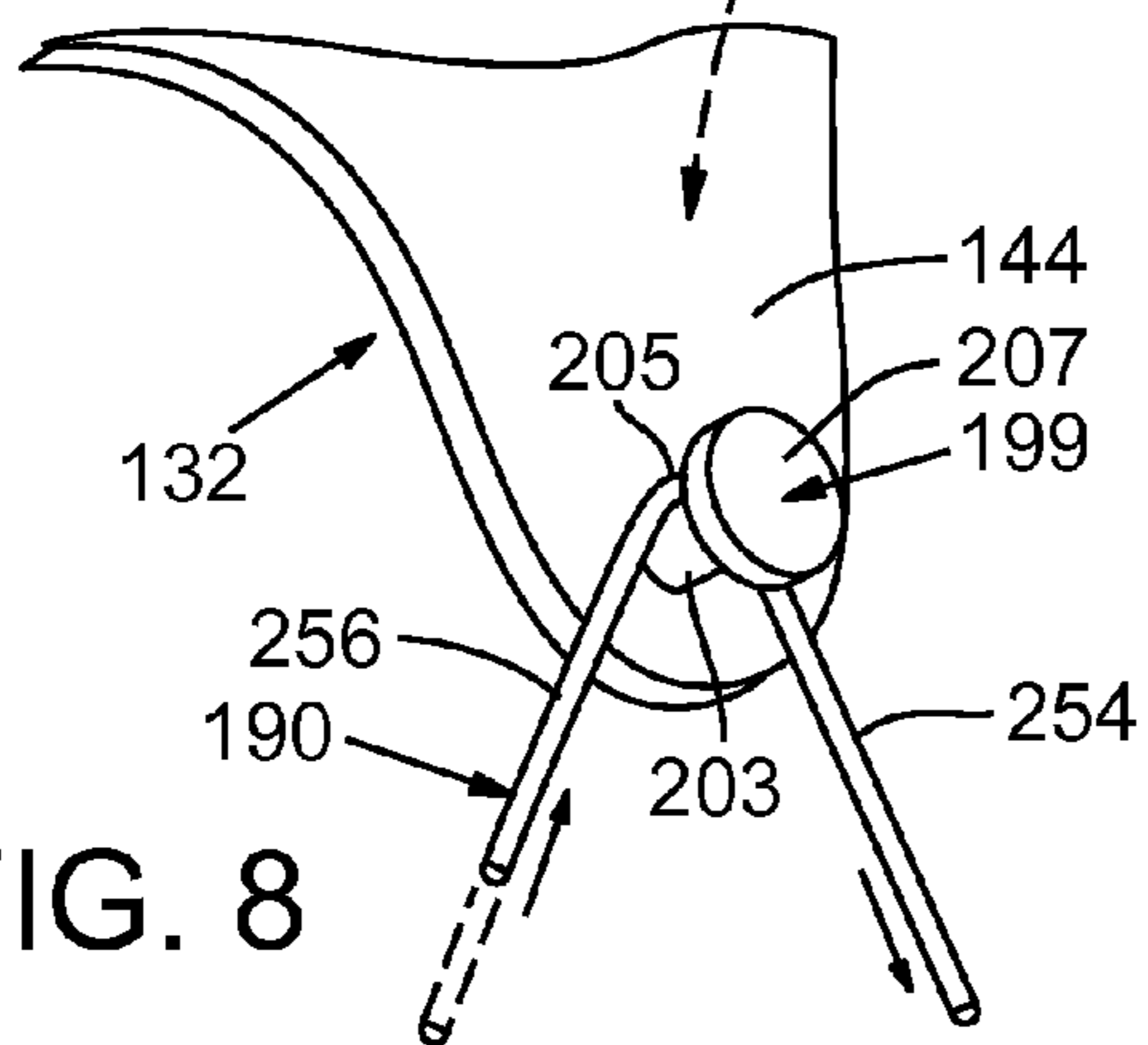
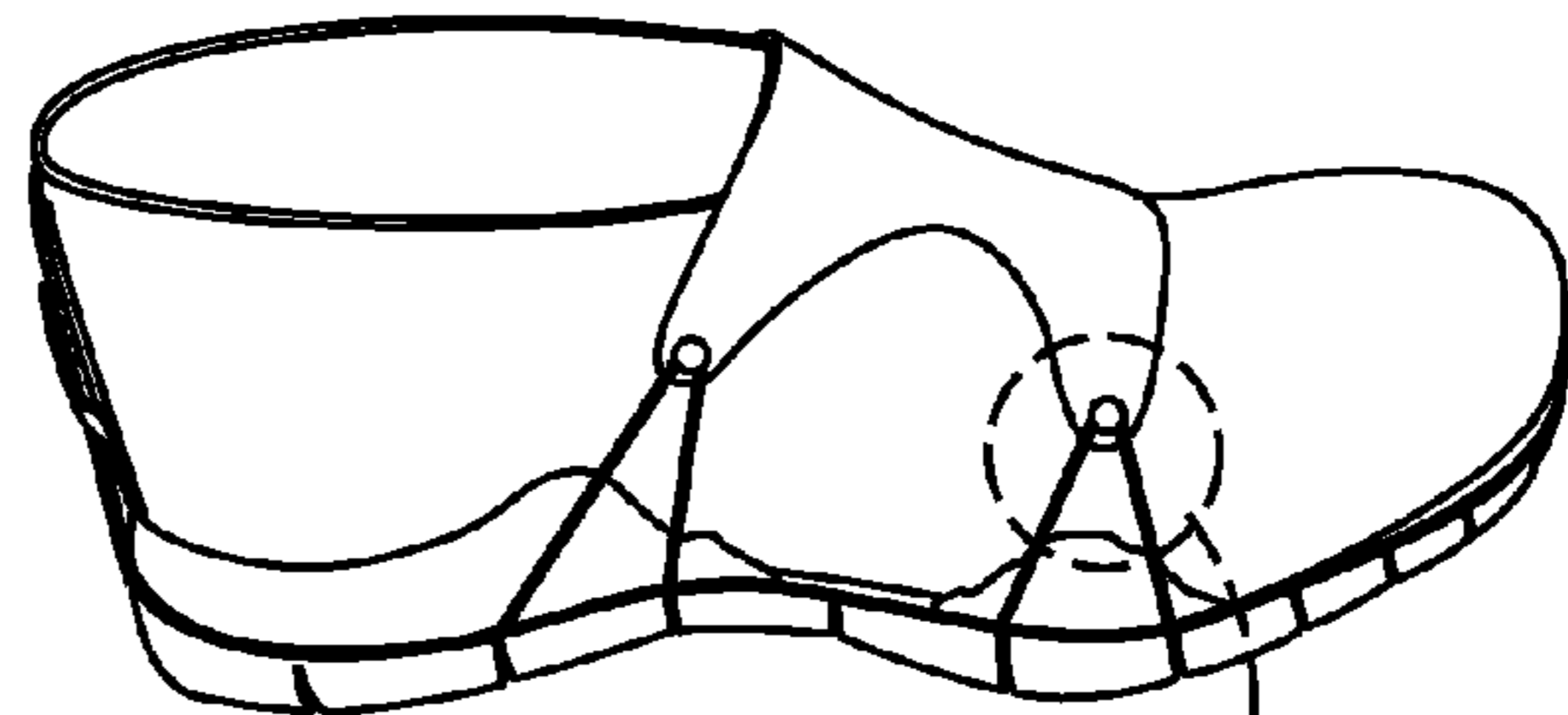
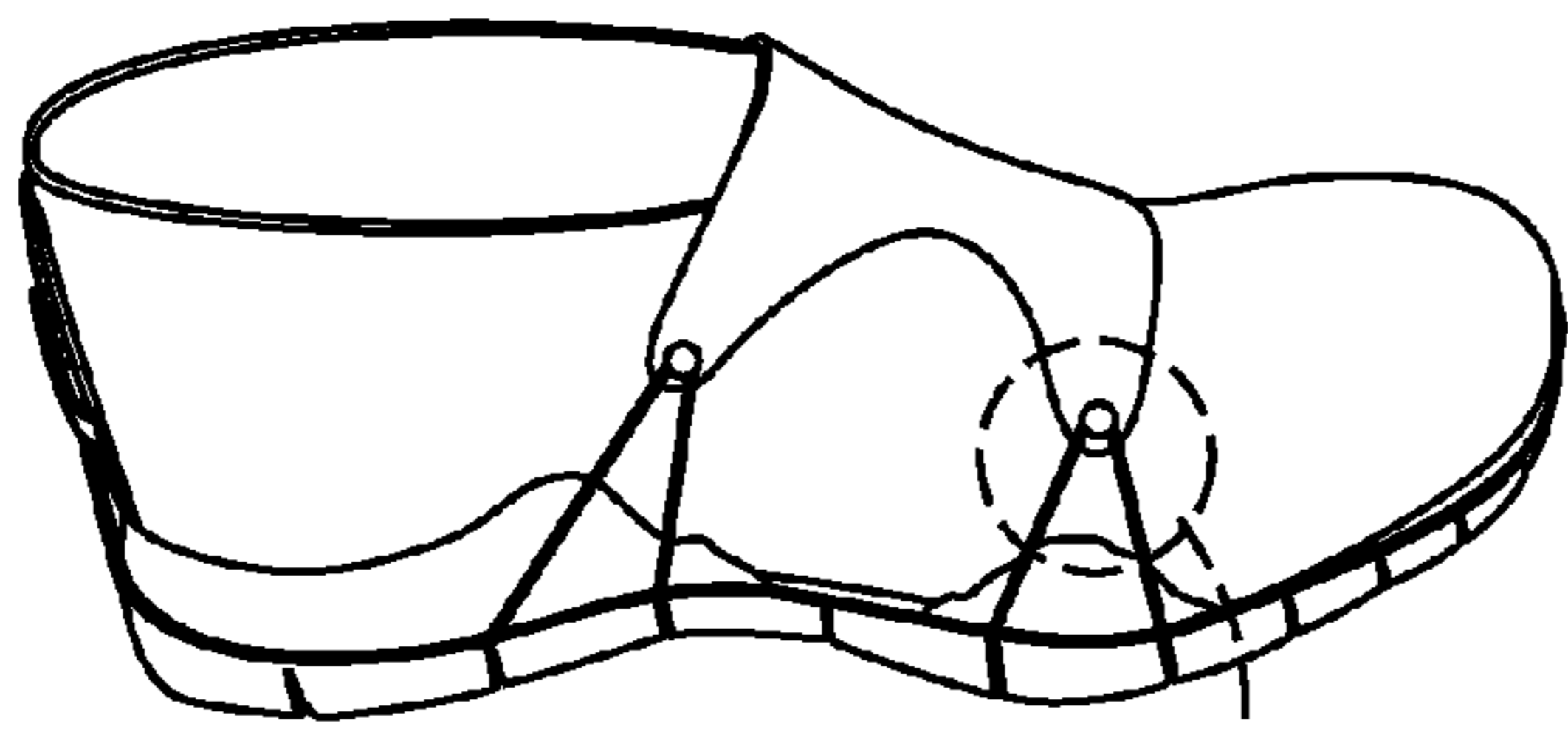

FIG. 8

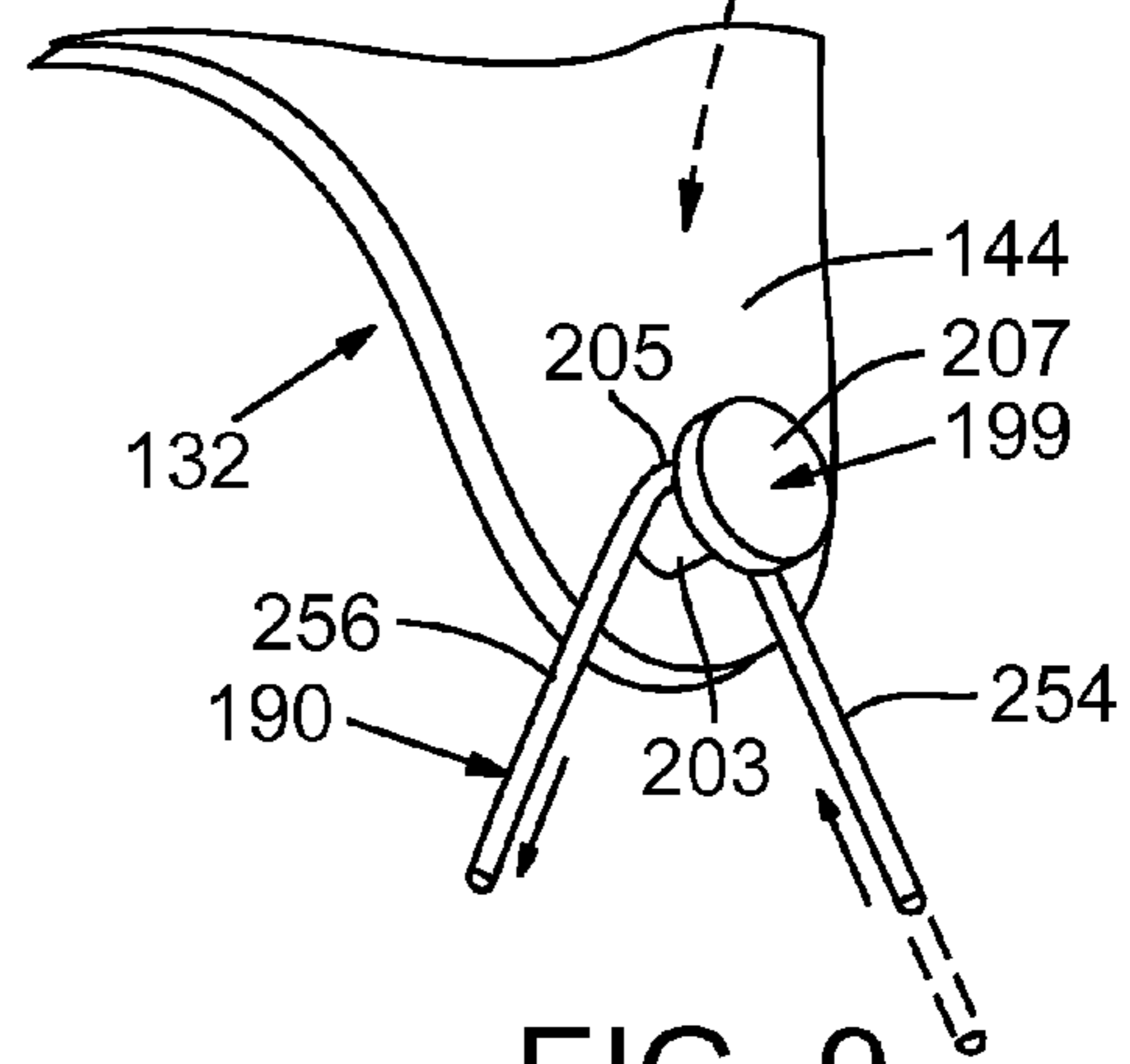

FIG. 9

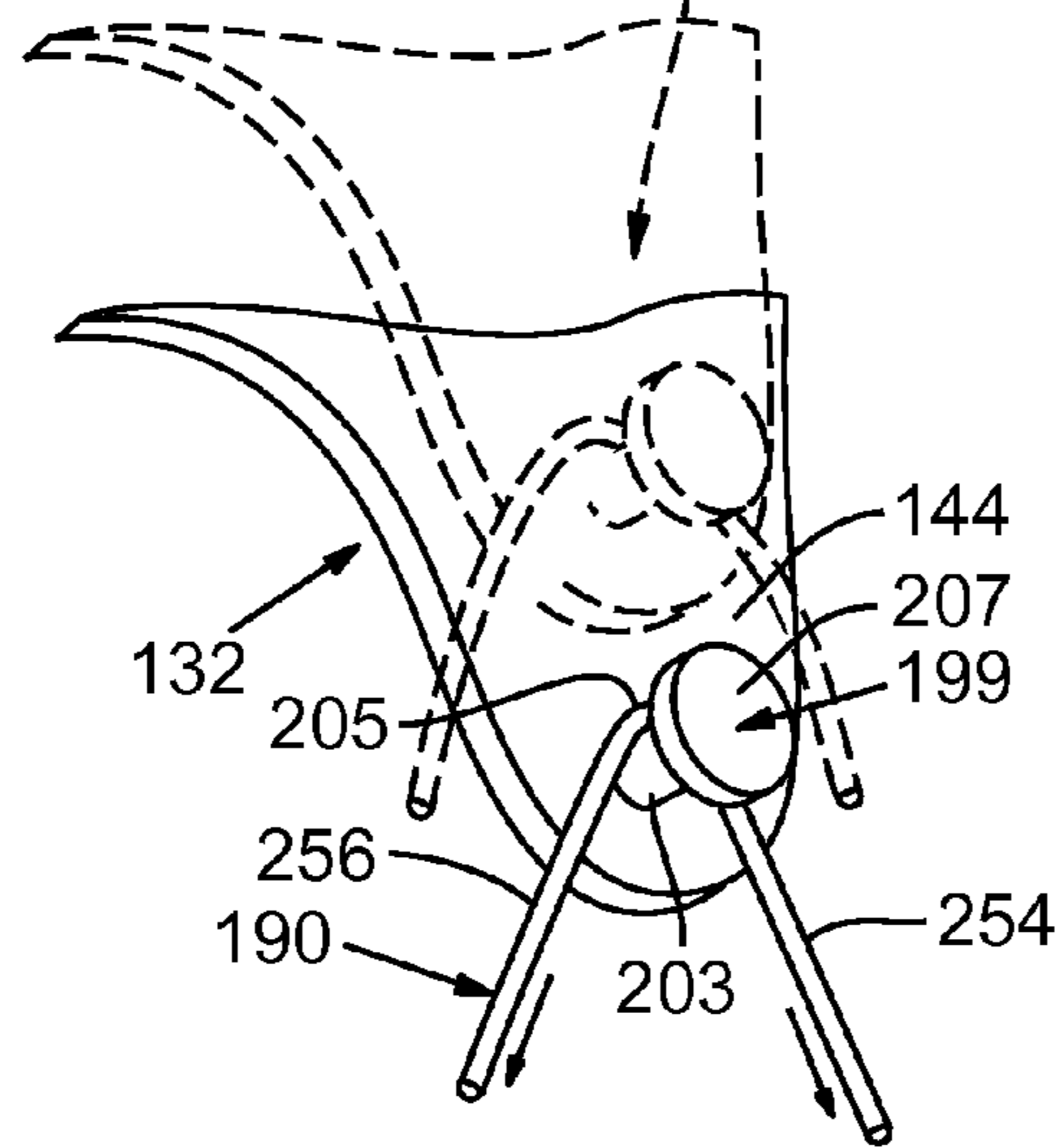
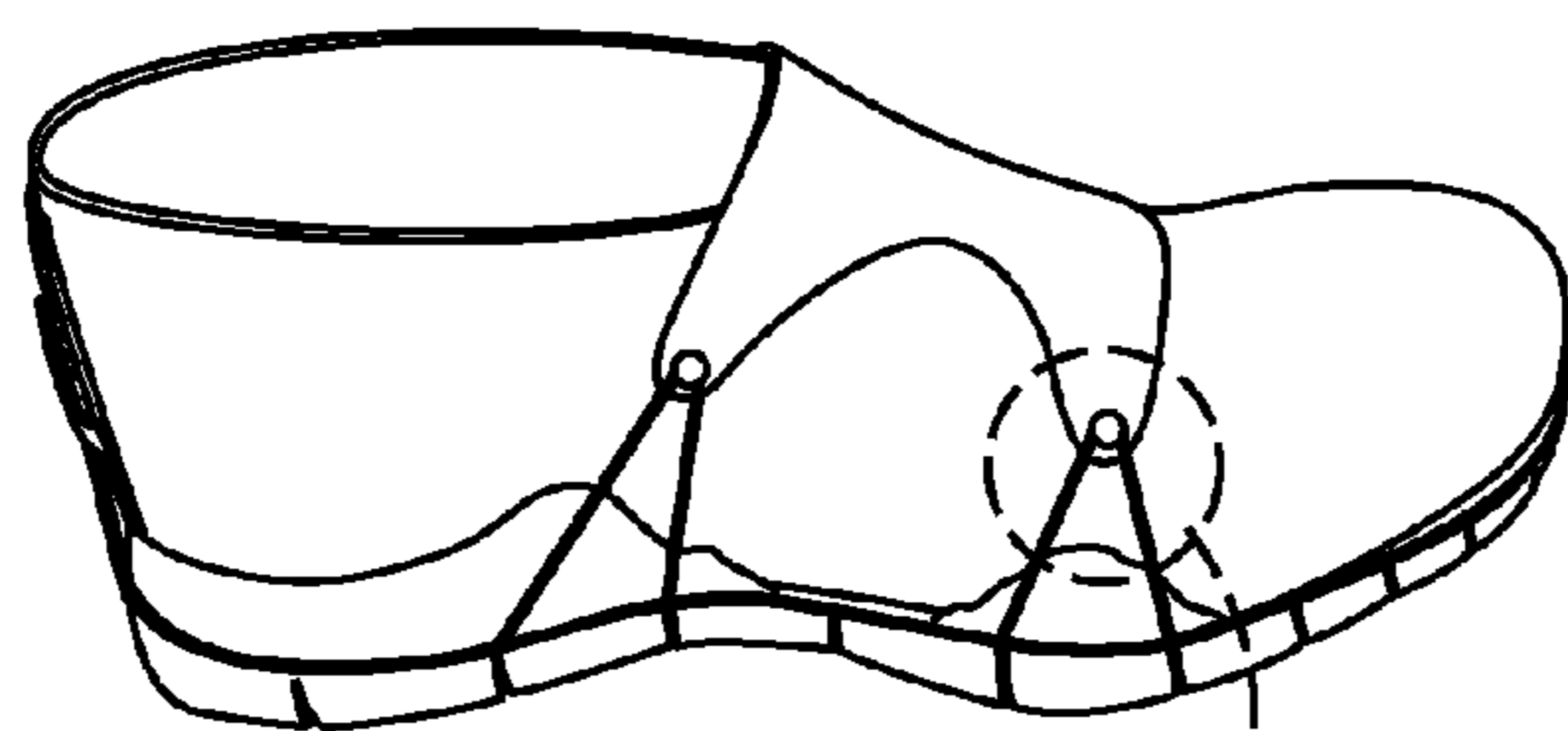

FIG. 10



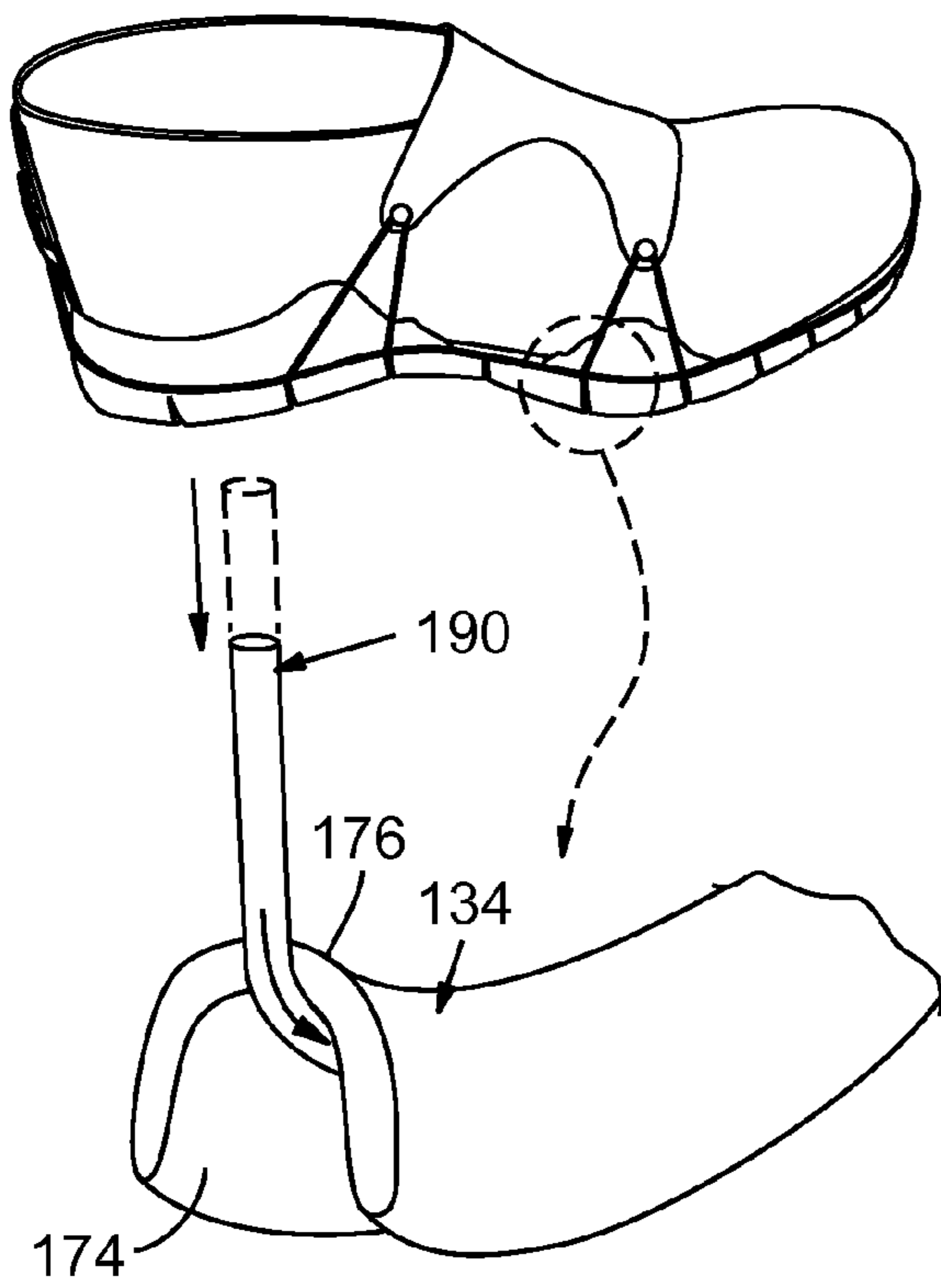

FIG. 11

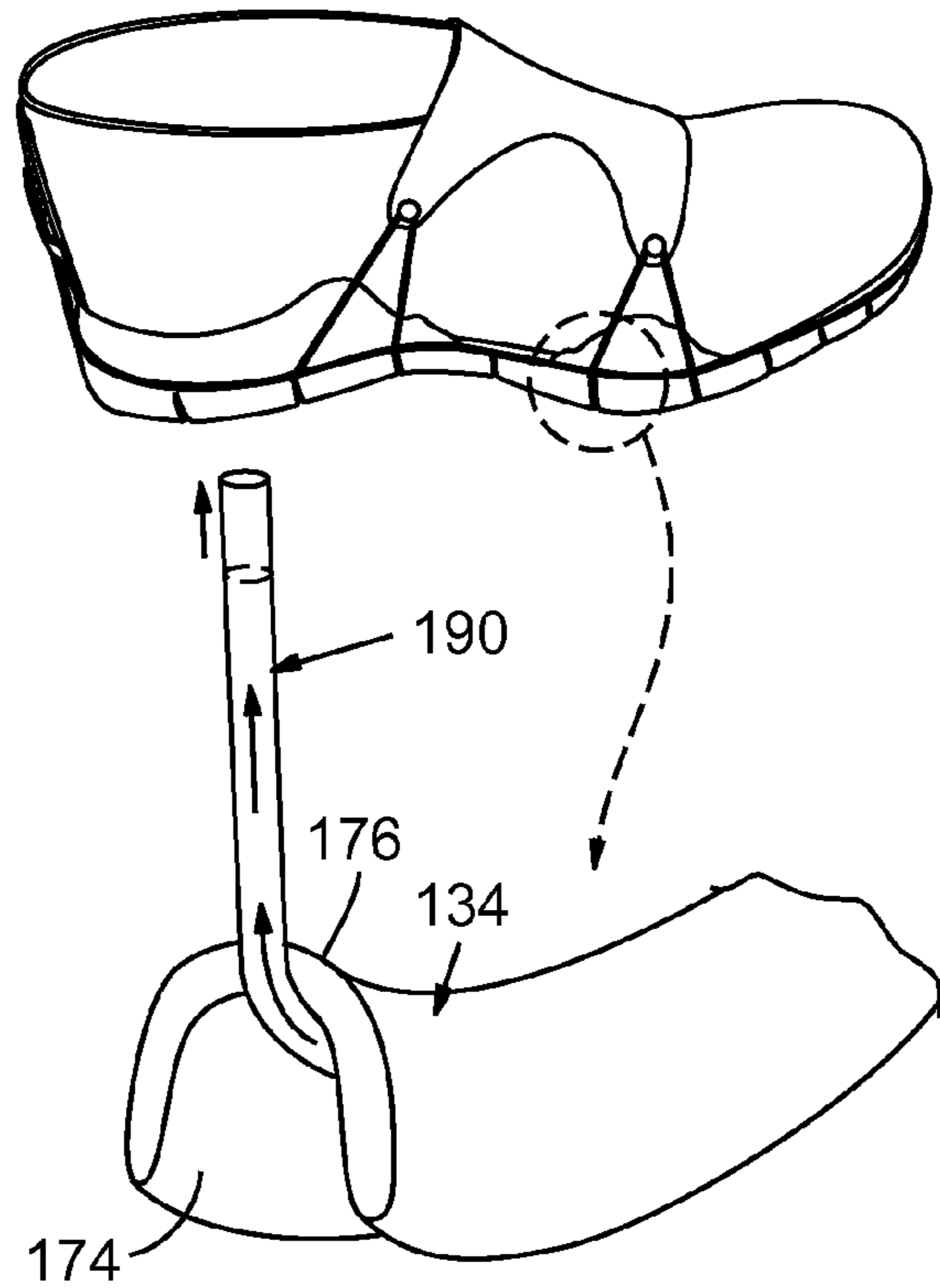

FIG. 12

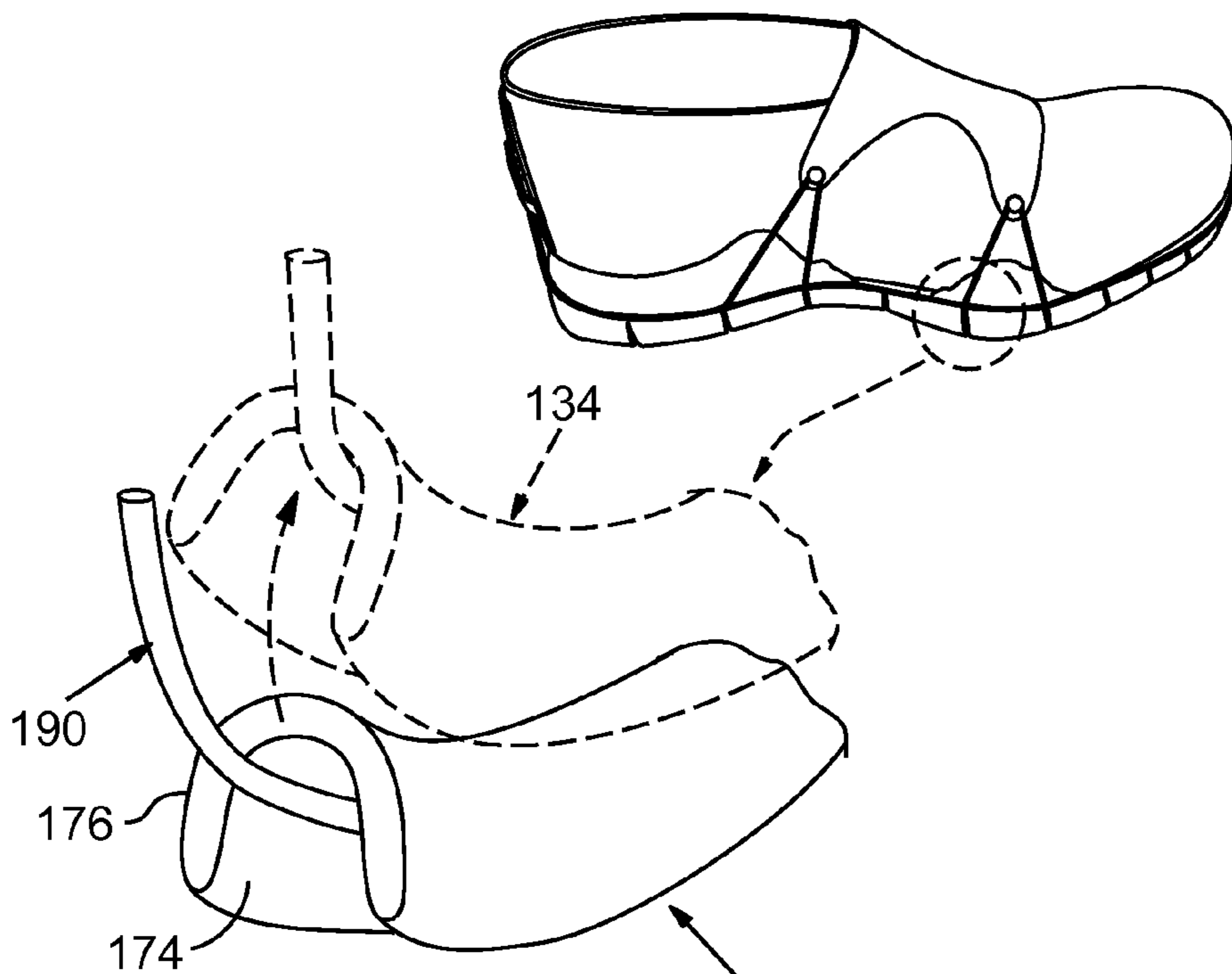

FIG. 13

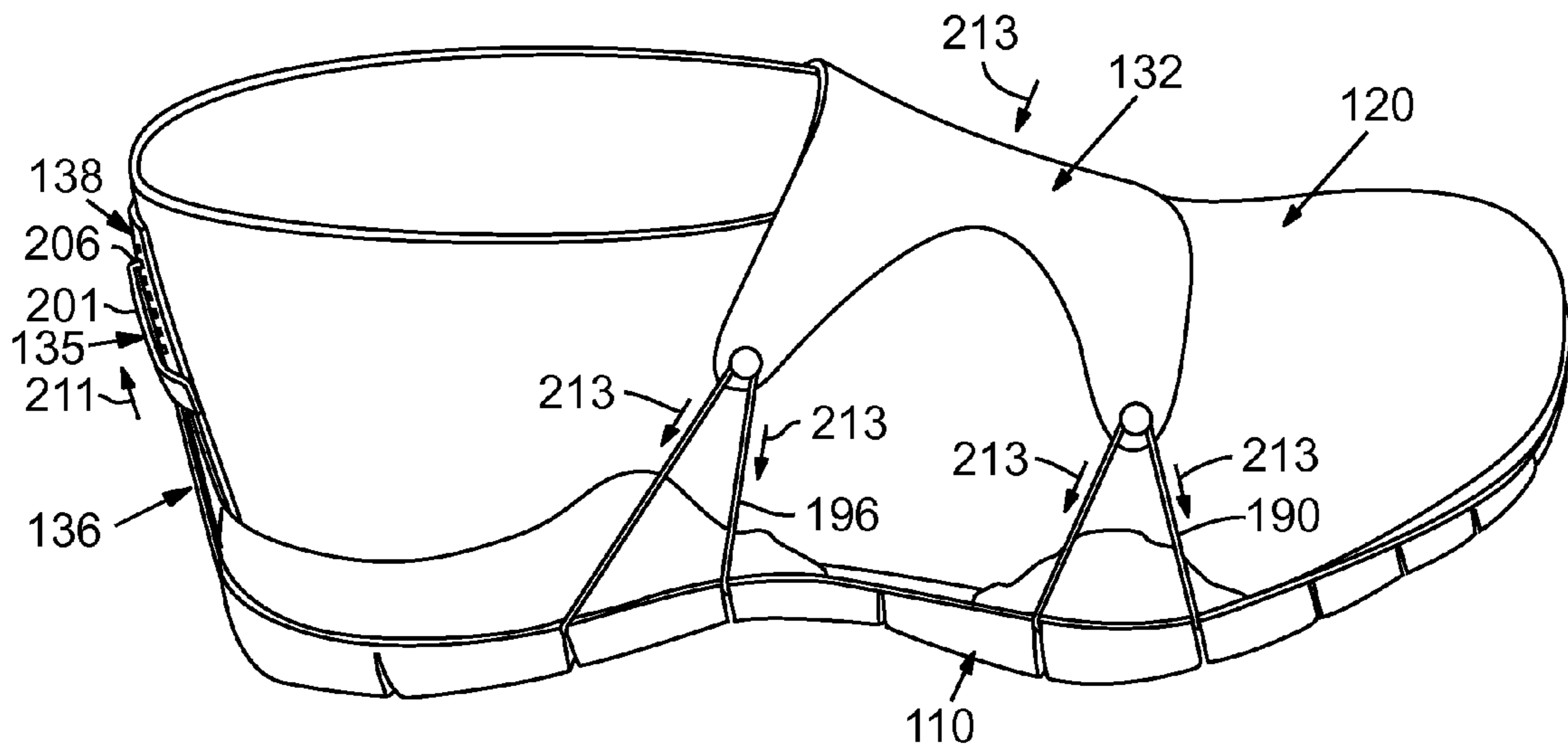

FIG. 14

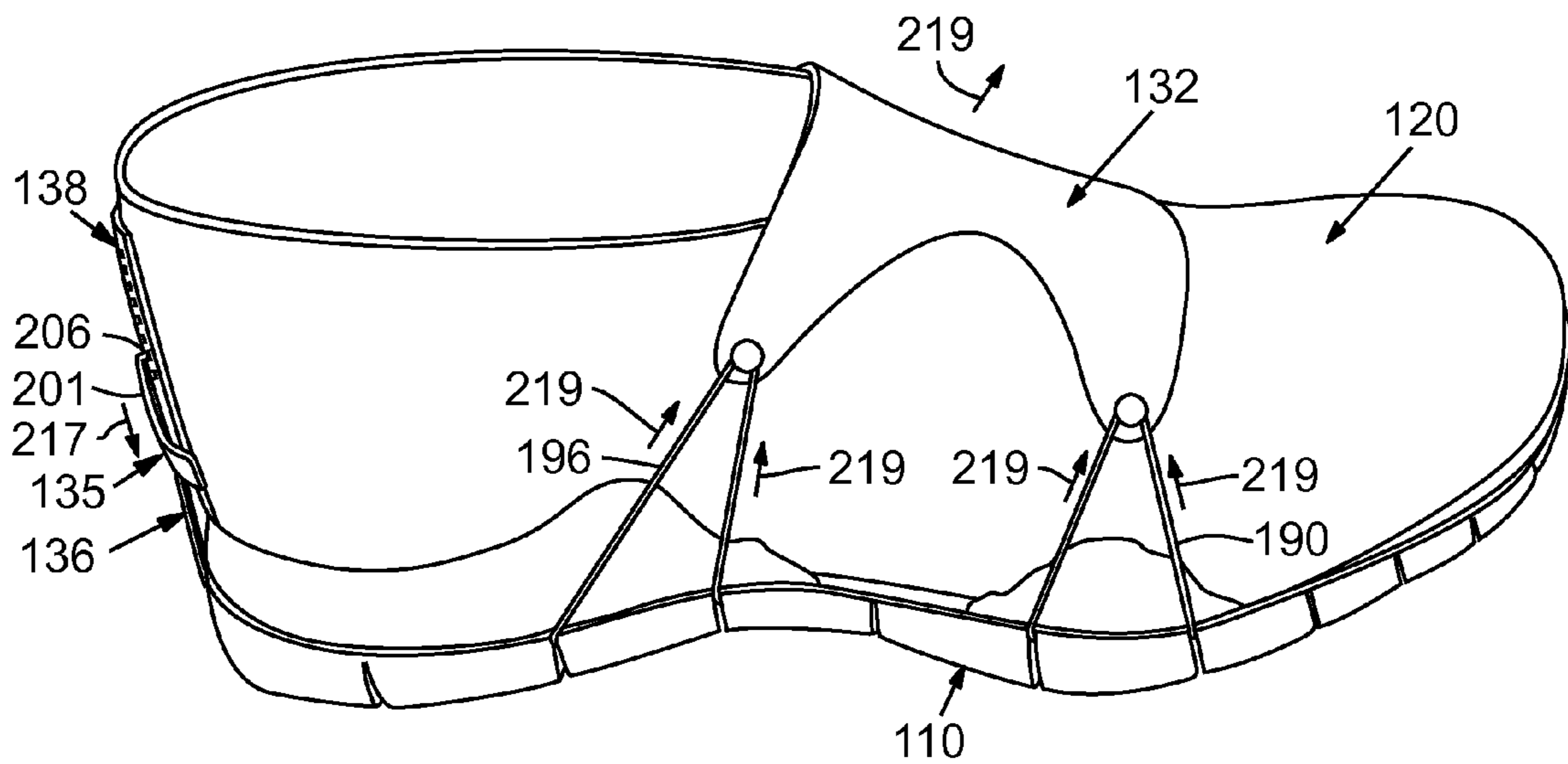

FIG. 15

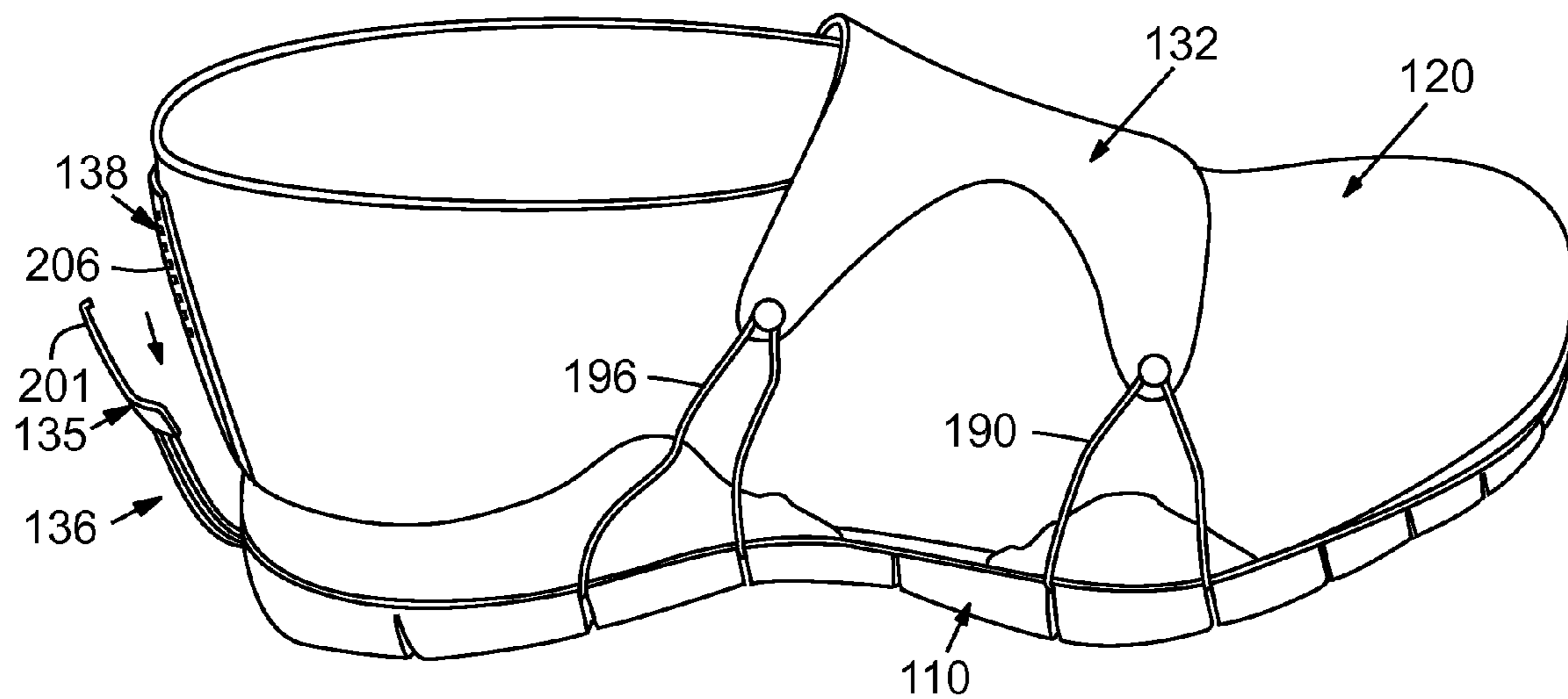
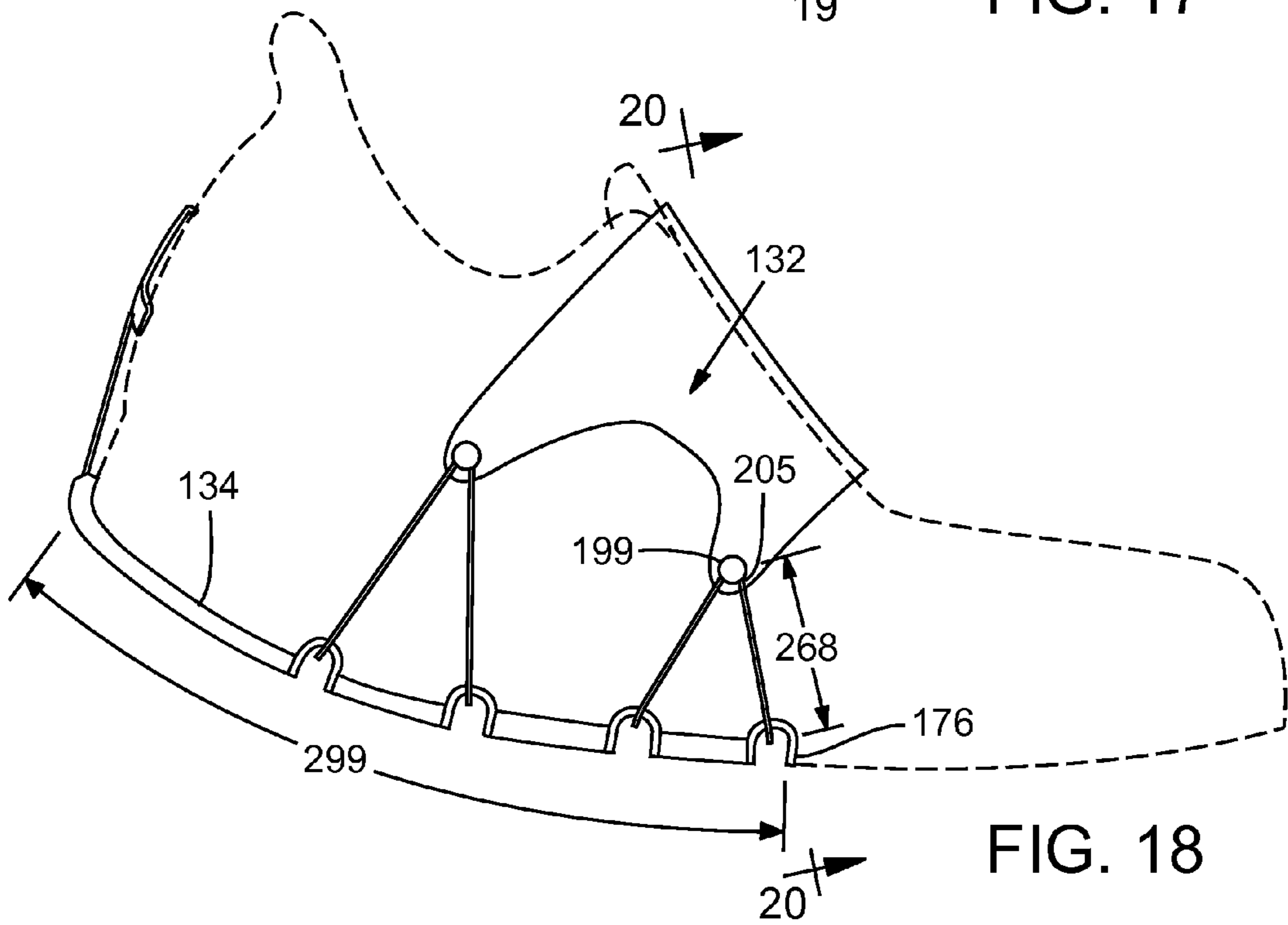
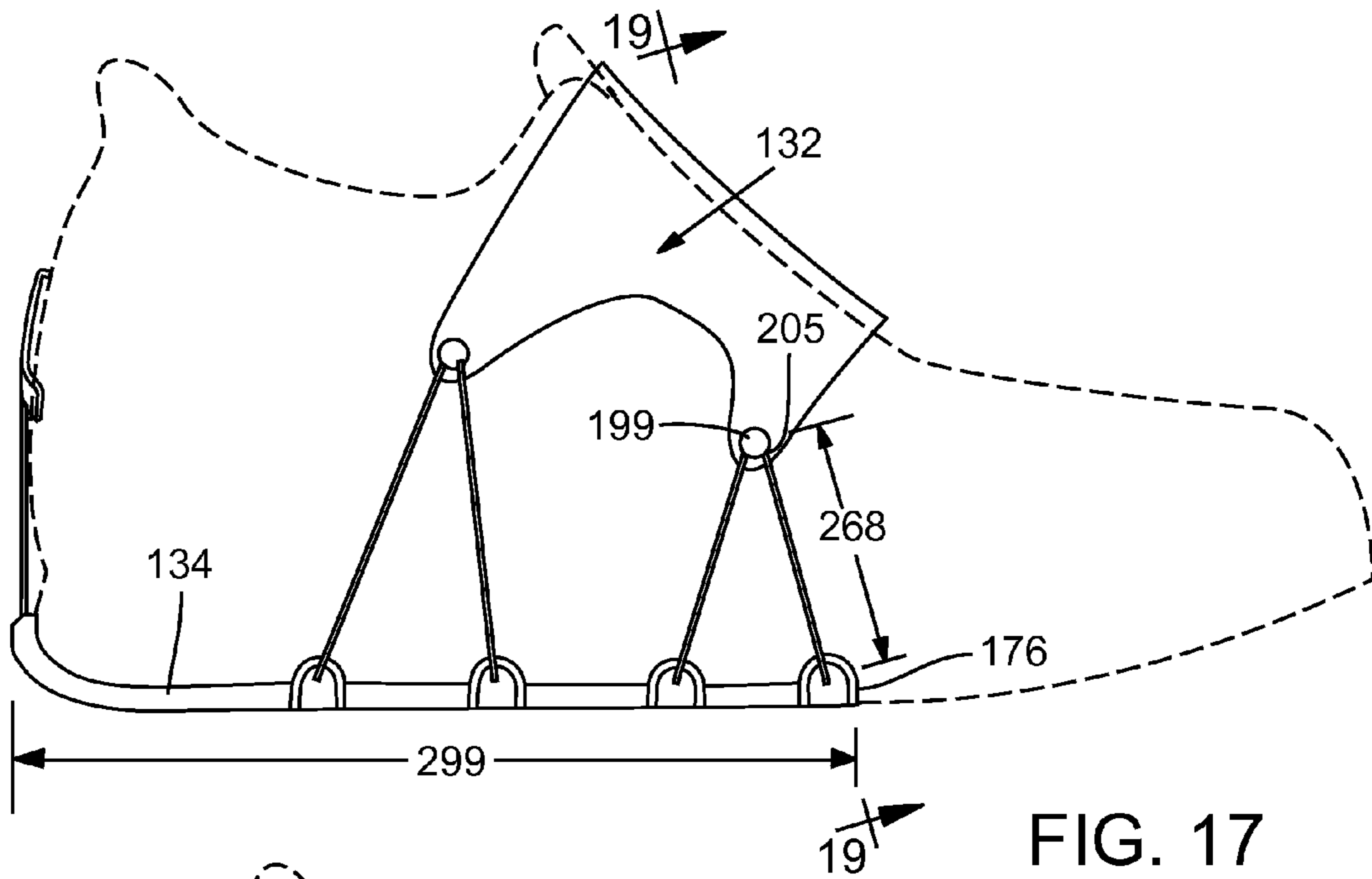

FIG. 16



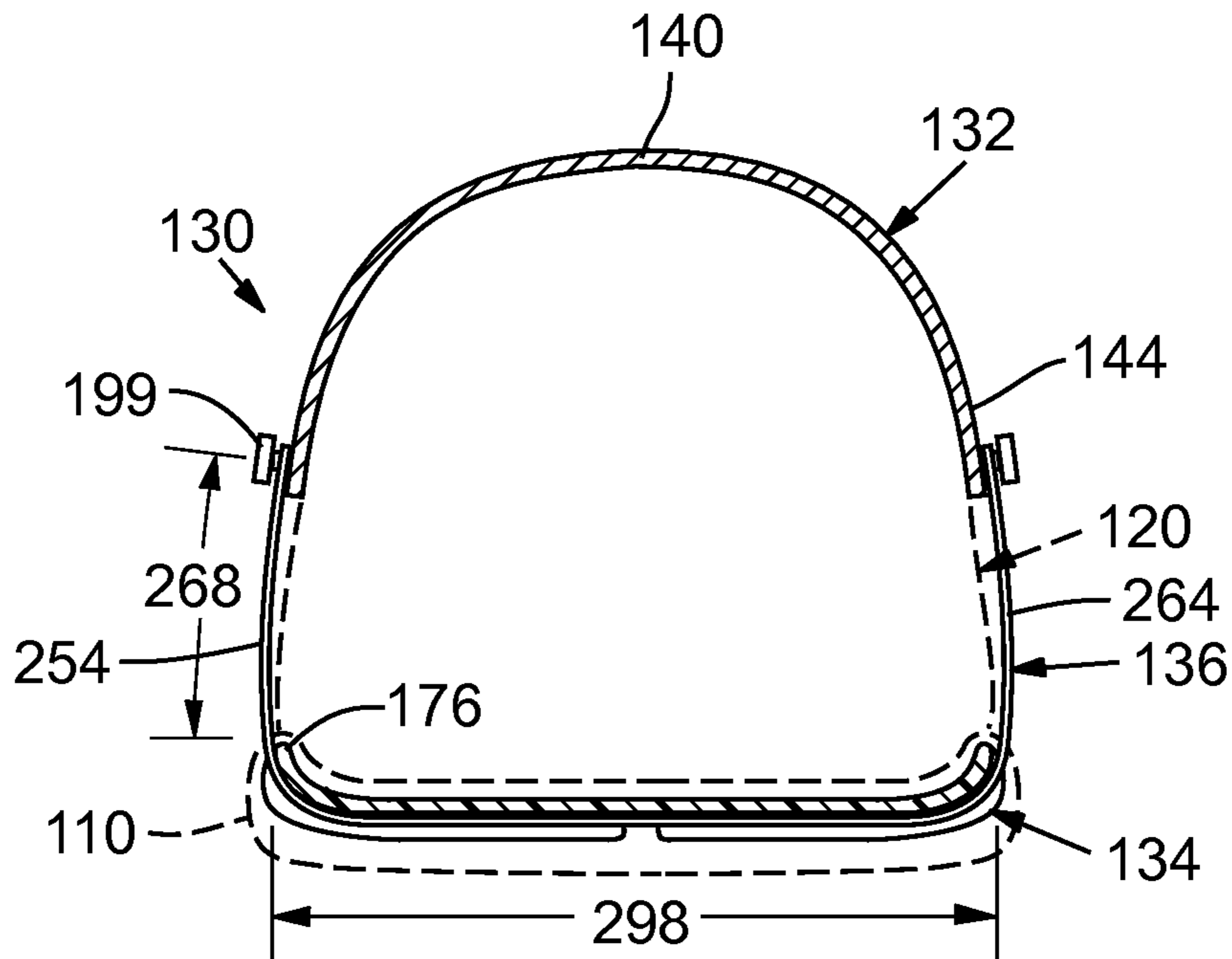

FIG. 19

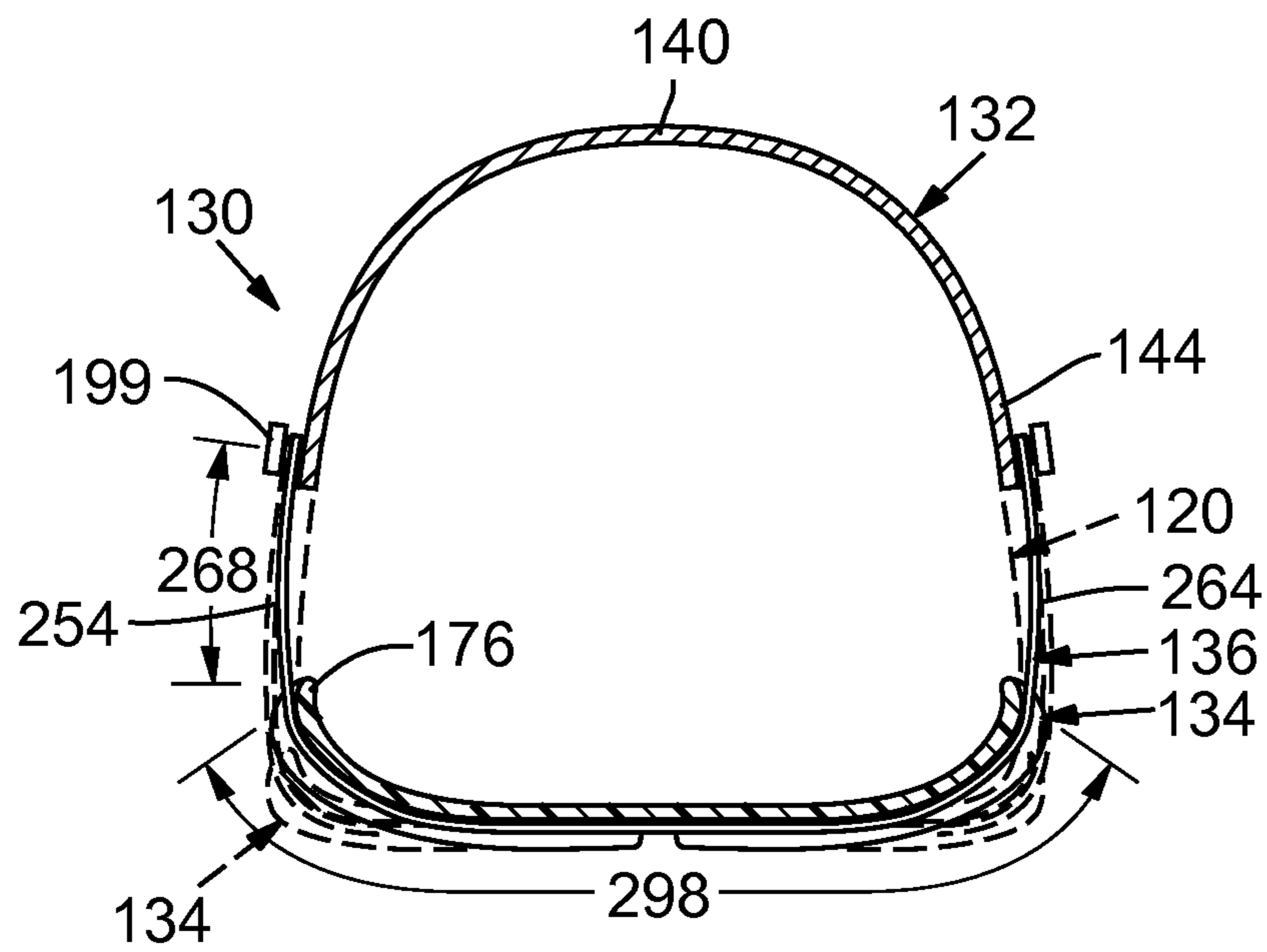

FIG. 20

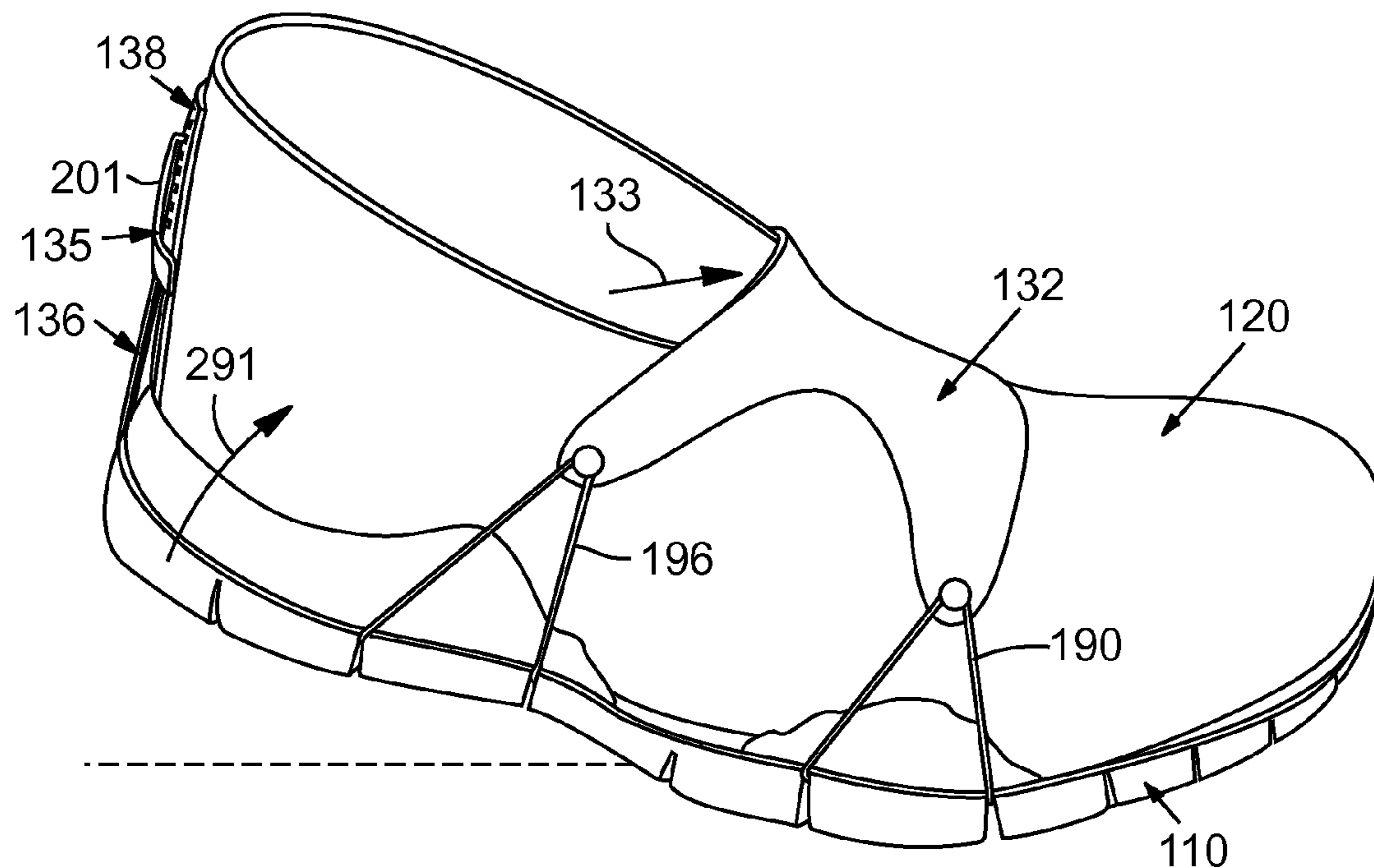

FIG. 21

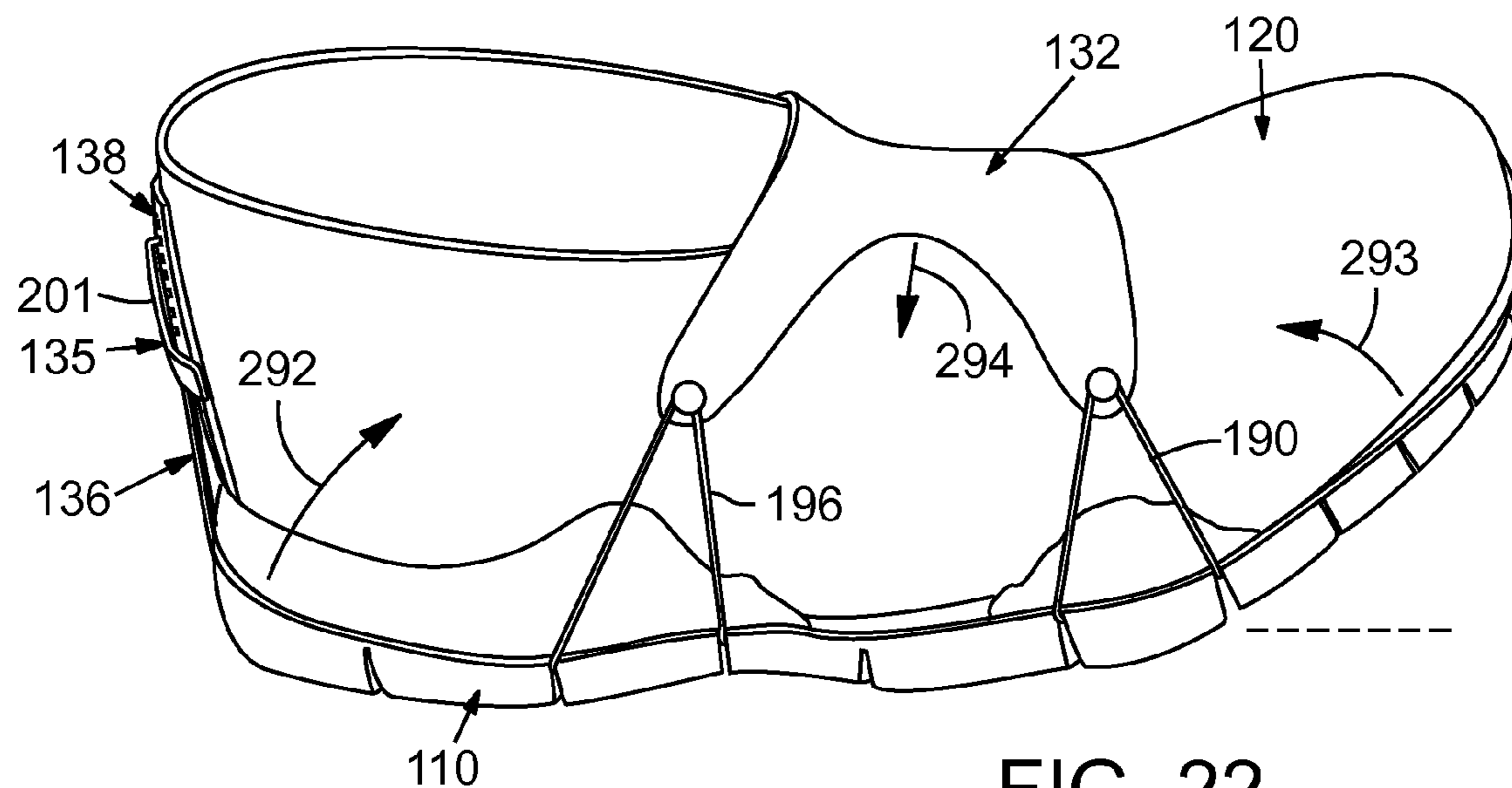

FIG. 22

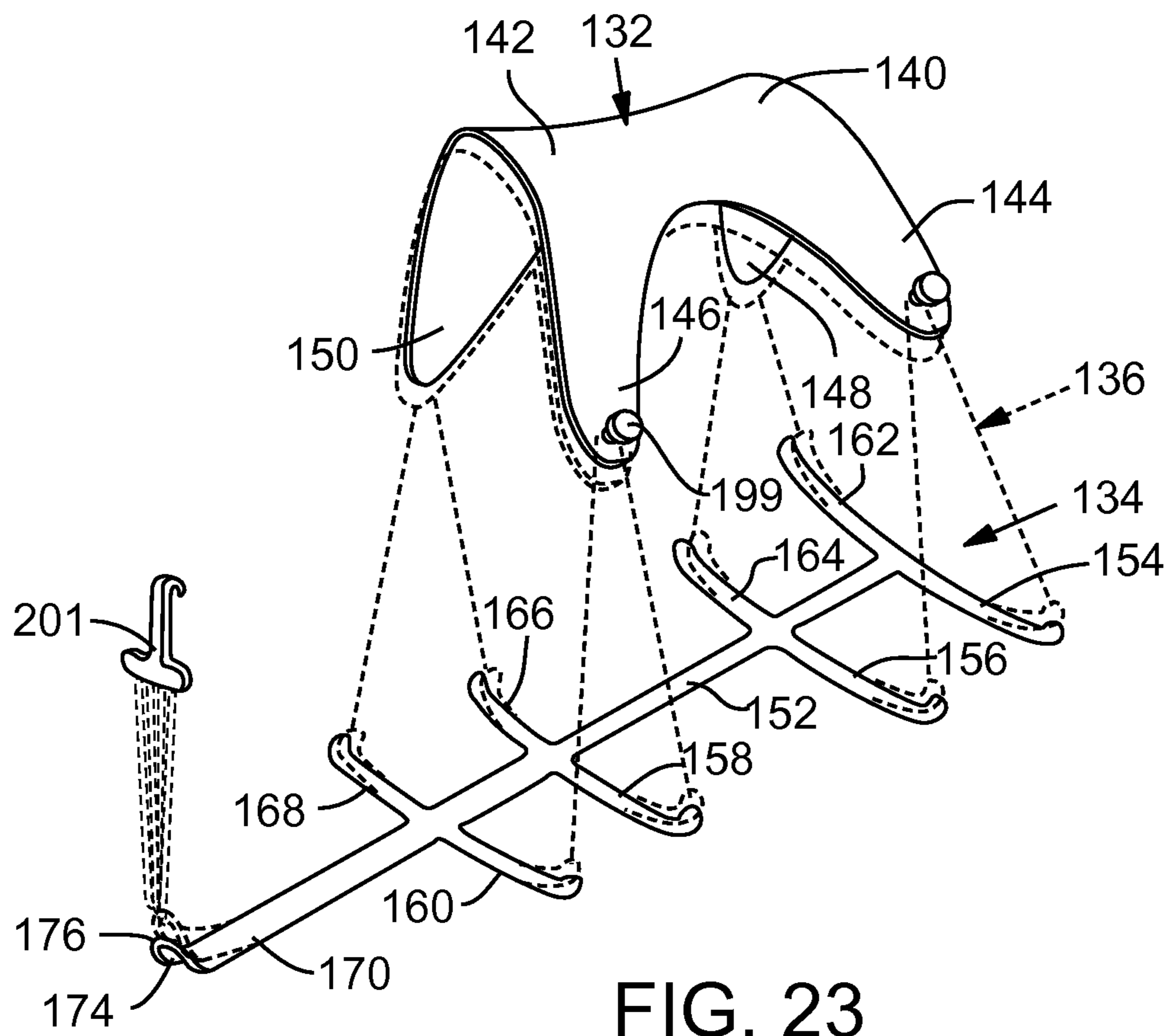
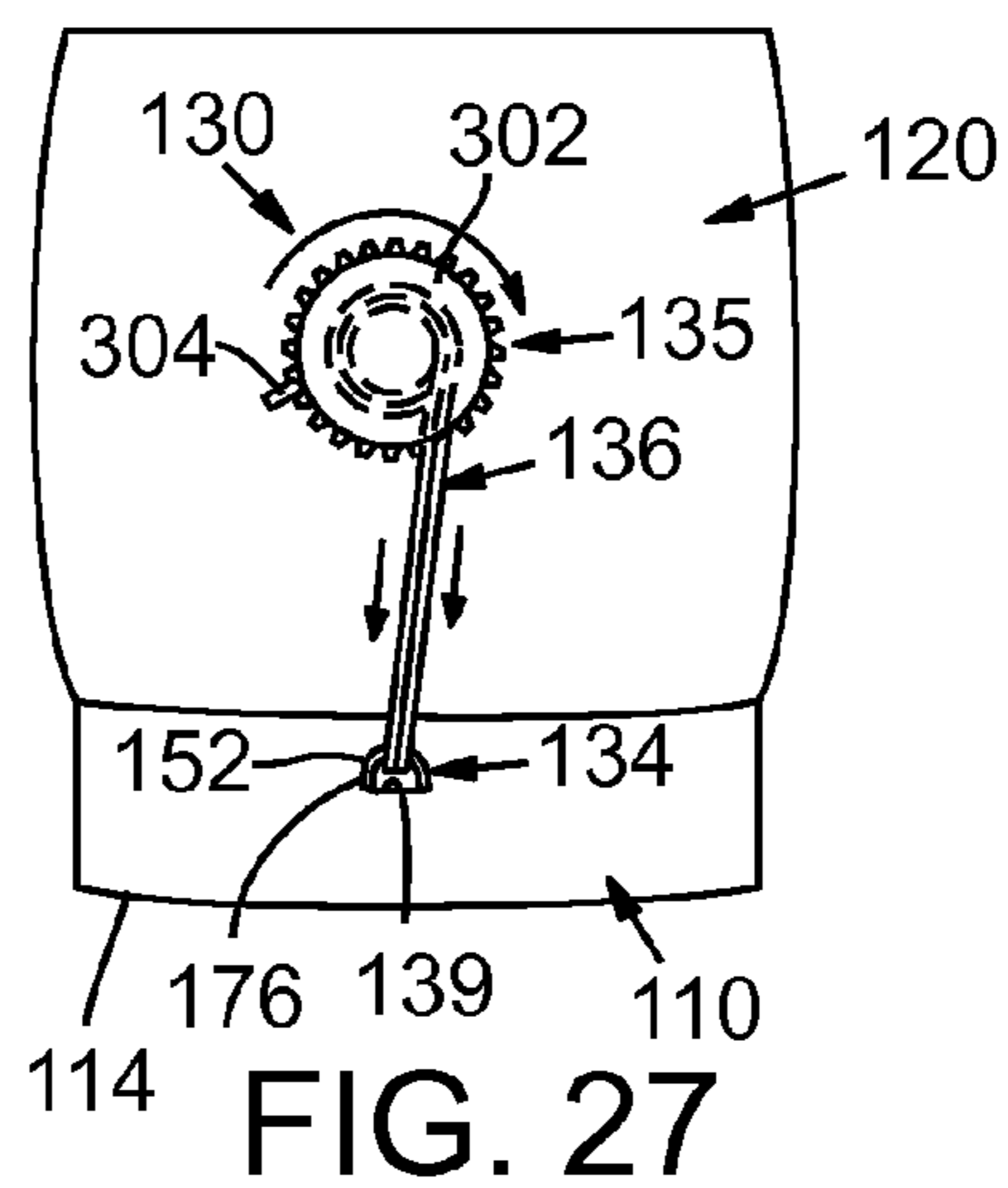
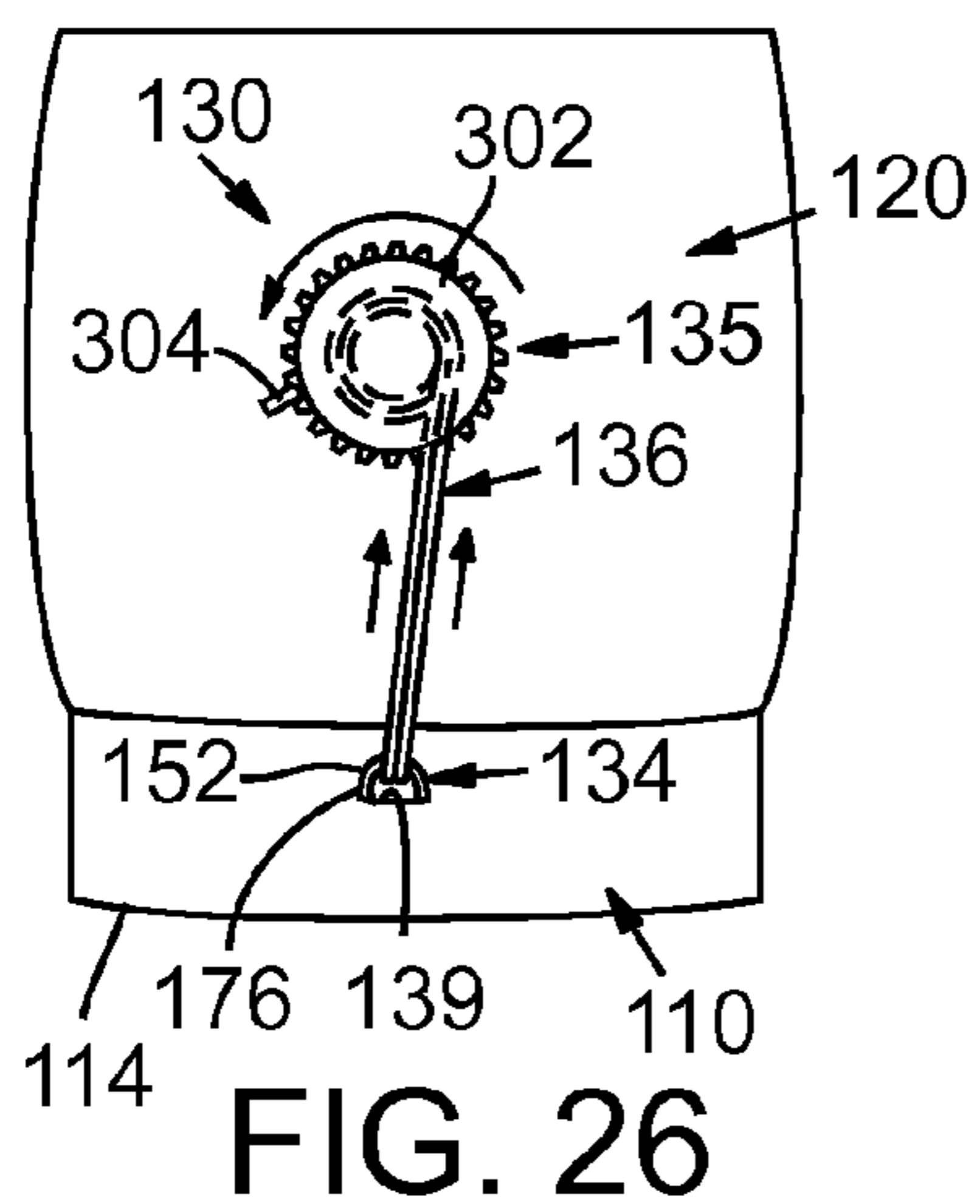
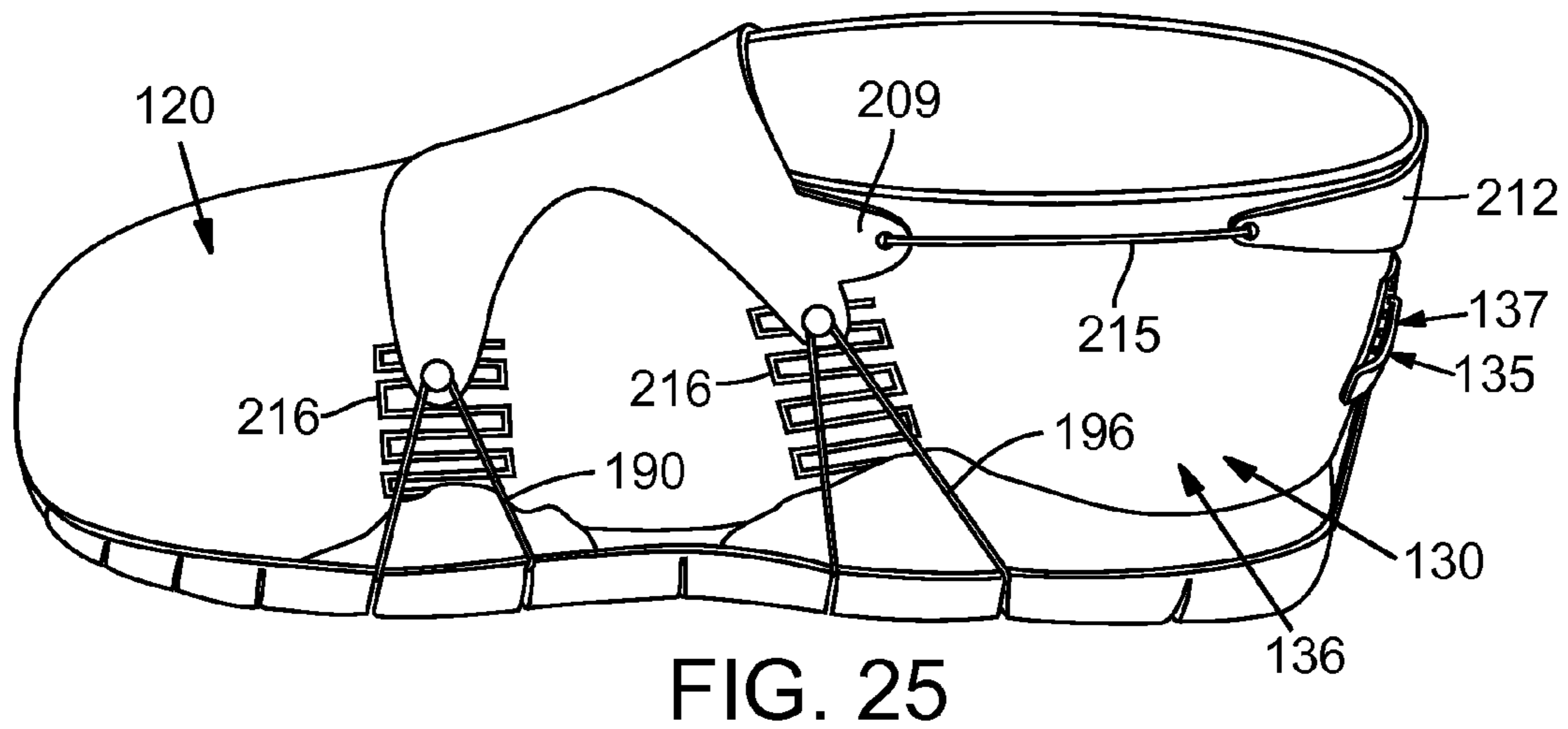
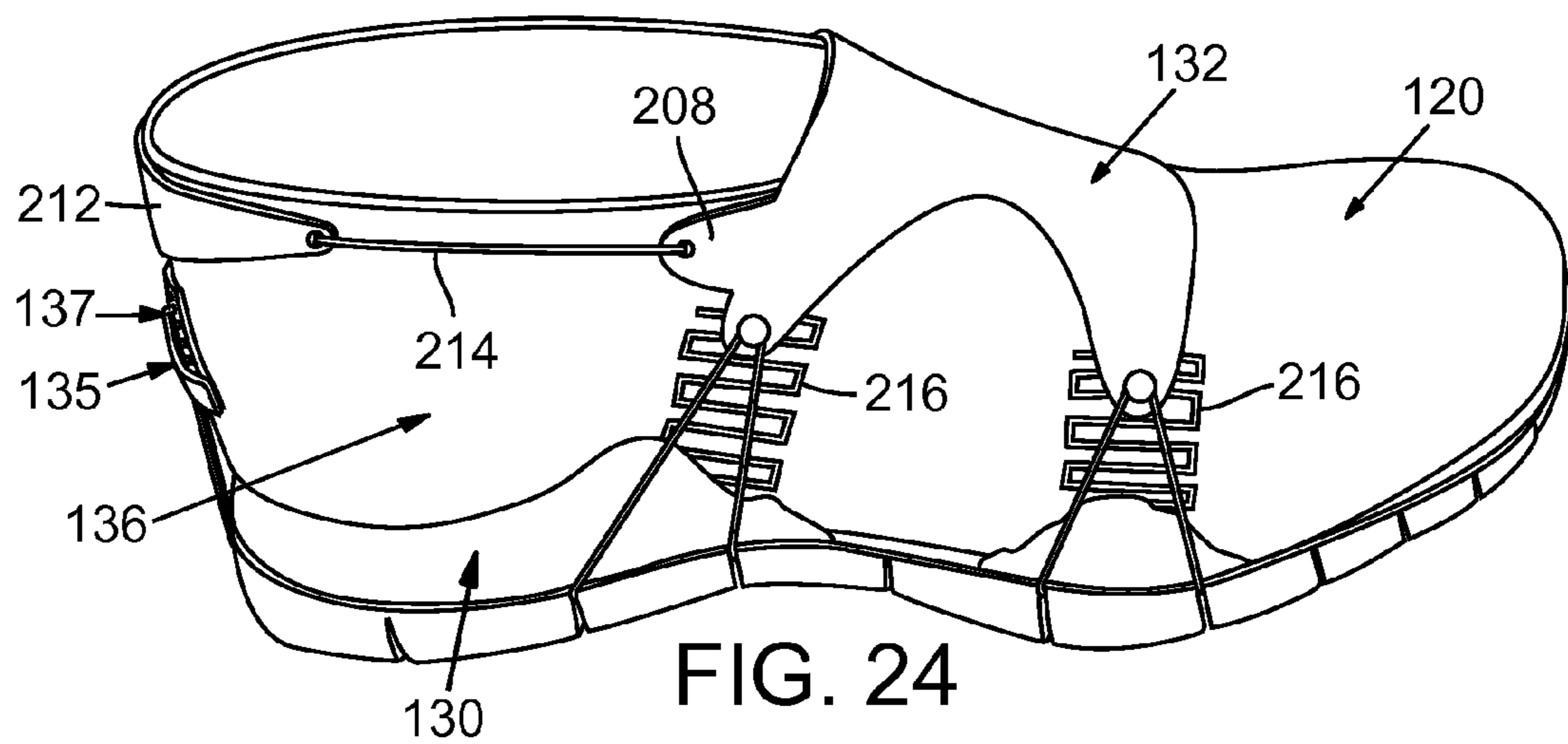
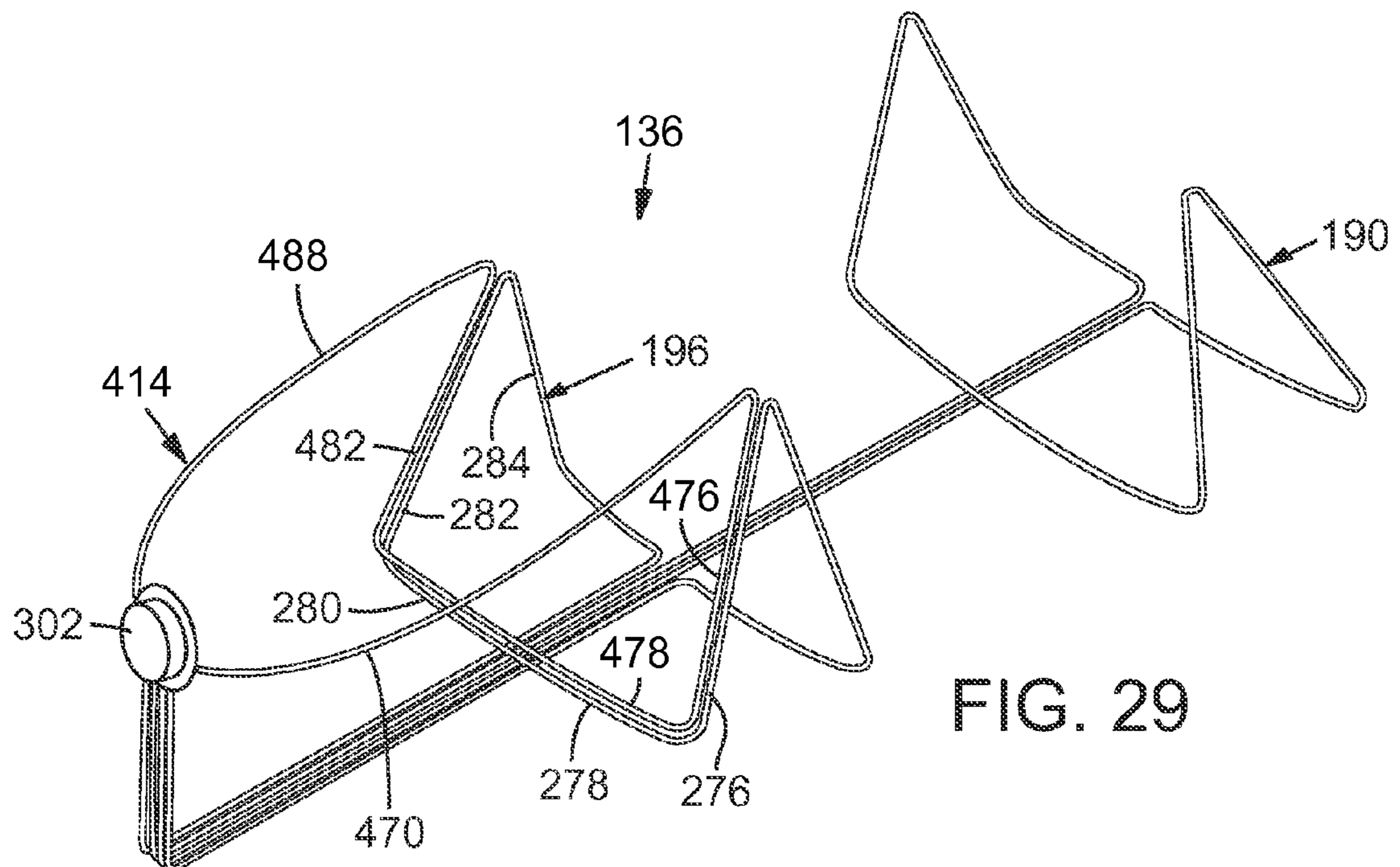
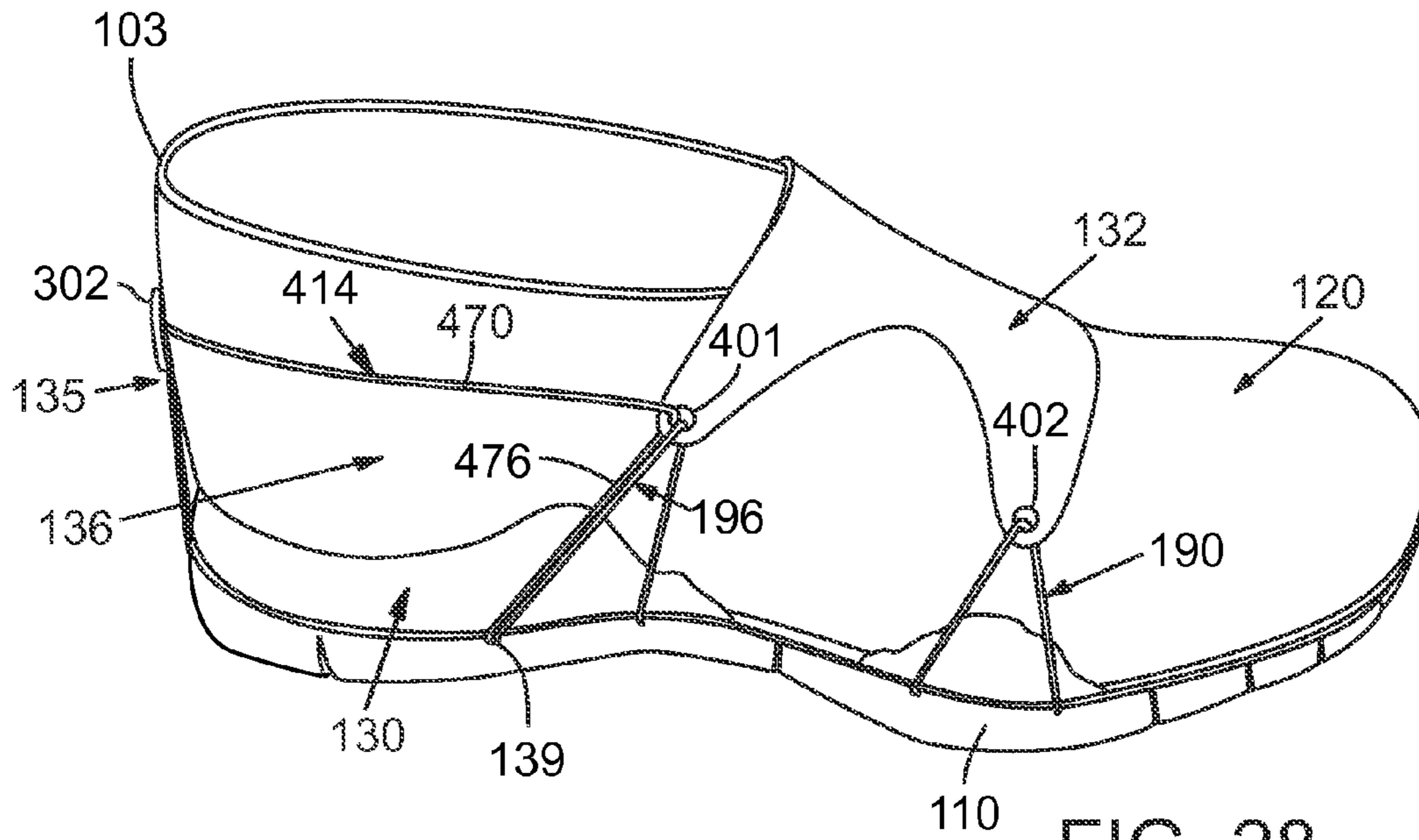

FIG. 23







## 1

**ARTICLE OF FOOTWEAR WITH  
ADJUSTABLE FITTING SYSTEM**

## BACKGROUND

## 1. Field

The following relates to an article of footwear and, more particularly, relates to an article of footwear with an adjustable fitting system.

## 2. Description of Related Art

This section provides background information related to the present disclosure which is not necessarily prior art.

Conventional articles of footwear generally include two primary elements, an upper and a sole structure. The upper is secured to the sole structure, and an interior surface of the upper defines a void for comfortably and securely receiving a foot. The sole structure is secured to a lower area of the upper, thereby being positioned between the upper and the ground. In athletic footwear, for example, the sole structure may include a midsole and an outsole. The midsole often includes a polymer foam material that attenuates ground reaction forces to lessen stresses upon the foot and leg during walking, running, and other ambulatory activities. Additionally, the midsole may include fluid-filled chambers, plates, moderators, or other elements that further attenuate forces, enhance stability, or influence the motions of the foot. The outsole is secured to a lower surface of the midsole and provides a ground-engaging portion of the sole structure formed from a durable and wear-resistant material, such as rubber. The sole structure may also include a sockliner positioned within the void and proximal a lower surface of the foot to enhance footwear comfort.

The upper generally extends over the instep and toe areas of the foot, along the medial and lateral sides of the foot and around the heel area of the foot. In some articles of footwear, such as basketball footwear and boots, the upper may extend upward and around the ankle to provide support or protection for the ankle. Access to the void on the interior of the upper is generally provided by an ankle opening in a heel region of the footwear. A lacing system is often incorporated into the upper to adjust the fit of the upper, thereby permitting entry and removal of the foot from the void within the upper. The lacing system also permits the wearer to modify certain dimensions of the upper, particularly girth, to accommodate feet with varying dimensions. In addition, the upper may include a tongue that extends under the lacing system to enhance adjustability of the footwear, and the upper may incorporate a heel counter to limit movement of the heel.

## SUMMARY

An article of footwear is disclosed that includes an upper that defines a void for receiving a foot. The article of footwear also includes a flexible sole structure that is coupled to the upper. Also, the article of footwear includes a fitting system. The fitting system includes an upper member that is supported by the upper. The fitting system also includes a strand guide that is supported by the sole structure. The strand guide is flexible and configured to flex in concert with the sole structure between a first position and a second position. The strand guide has a guide surface. The fitting system further includes a tensioning system with a flexible strand that is configured to bias the upper member toward the strand guide. The flexible strand has a first section coupled to the upper member and a second section extending through the sole structure. The second section abuts the guide surface. The second section is configured to slide across the guide surface

## 2

as a result of flexure of the strand guide between the first position and the second position. The first section and the upper member are configured to move relative to the sole structure as a result of sliding of the second section across the guide surface.

Additionally, an article of footwear having a medial side, a lateral side, and a longitudinal axis is disclosed. The article of footwear includes an upper that defines a void for receiving a foot. The article of footwear also includes a flexible sole structure that is coupled to the upper. Moreover, the article of footwear includes a fitting system. The fitting system includes an upper member that is supported by the upper and a strand guide that is supported by the sole structure. The strand guide is flexible and configured to flex in concert with the sole structure between a first position and a second position. The fitting system also includes a tensioning system with at least one flexible strand that is configured to bias the upper member toward the strand guide. The flexible strand has a medial portion, a lateral portion, and a central portion. The medial portion is coupled to the upper member at the medial side. The lateral portion is coupled to the upper member at the lateral side. The central portion extends through the sole structure and abuts the strand guide. The central portion is configured to slide across the strand guide as a result of flexure of the strand guide between the first position and the second position.

Still further, an article of footwear having a longitudinal axis extending between a heel region and a forefoot region of the article of footwear is disclosed. The article of footwear includes an upper that defines a void for receiving a foot. The article of footwear also includes a sole structure that is coupled to the upper. Additionally, the article of footwear includes a fitting system. The fitting system includes an upper member that is supported by the upper. The fitting system also includes a strand guide that is supported by the sole structure. The strand guide is flexible and configured to flex in concert with the sole structure between a first position and a second position. The strand guide includes a longitudinal member that extends along the longitudinal axis of the article of footwear. The strand guide also includes a transverse member that extends transversely from the longitudinal member. The strand guide also includes a guide surface that extends continuously across each of the longitudinal member and the transverse member. The fitting system further includes a tensioning system with at least one flexible strand. The strand includes a first section, a second section, a third section, and a fourth section. The first section, the second section, the third section, and the fourth section are arranged continuously in succession along a longitudinal axis of the strand. The first section is attached to the heel region, the second section extends through the sole structure along the guide surface of the longitudinal member, the third section extends transversely from the second section through the sole structure and along the guide surface of the transverse member, and the fourth section extends from the third section and is attached to the upper member.

Other systems, methods, features and advantages of the present disclosure will be, or will become, apparent to one of ordinary skill in the art upon examination of the following figures and detailed description. It is intended that all such additional systems, methods, features and advantages be included within this description and this summary, be within the scope of the present disclosure, and be protected by the following claims.

## BRIEF DESCRIPTION OF THE DRAWINGS

The present disclosure can be better understood with reference to the following drawings and description. The com-

ponents in the figures are not necessarily to scale, emphasis instead being placed upon illustrating the principles of the present disclosure. Moreover, in the figures, like reference numerals designate corresponding parts throughout the different views.

FIG. 1 is a lateral view of an article of footwear with a compressive fitting system according to exemplary embodiments of the present disclosure;

FIG. 2 is a medial view of the article of footwear of FIG. 1;

FIG. 3 is an exploded perspective view of the article of footwear of FIG. 1;

FIG. 4 is an exploded view of the compressive fitting system of the article of footwear of FIG. 1;

FIG. 5 is a bottom view of a strand guide of the compressive fitting system of FIG. 1 with a peripheral edge of the sole structure shown in phantom;

FIG. 6 is an inverted rear view of the strand guide of FIG. 5;

FIG. 7 is a perspective view of a tensioning system of the compressive fitting system of the article of footwear of FIG. 1;

FIGS. 8 and 9 are perspective views of portions of the tensioning system and upper member of the compressive fitting system of FIG. 1;

FIG. 10 is a perspective view of the tensioning system shown pulling the upper member of the compressive fitting of FIG. 1 toward the sole structure;

FIGS. 11 and 12 are perspective views of portions of the tensioning system and strand guide of the compressive fitting system of FIG. 1;

FIG. 13 is a perspective view of the tensioning system and strand guide shown in flexion;

FIG. 14 is a lateral view of the article of footwear of FIG. 1 with the compressive fitting system shown at a first fastened configuration;

FIG. 15 is a lateral view of the article of footwear of FIG. 1 with the compressive fitting system shown at a second fastened configuration;

FIG. 16 is a lateral view of the article of footwear of FIG. 1 with the compressive fitting system shown at an unfastened configuration;

FIG. 17 is a side view of the compressive fitting system shown in a neutral position with the upper and the sole structure shown in phantom;

FIG. 18 is a side view of the compressive fitting system shown in a flexed position with the upper and the sole structure shown in phantom;

FIG. 19 is a section view of the article of footwear with the upper and the sole structure shown in phantom and the compressive fitting system shown in a neutral position;

FIG. 20 is a section view of the article of footwear with the upper and the sole structure shown in phantom and the compressive fitting system shown in a flexed position;

FIG. 21 is a lateral view of the article of footwear of FIG. 1 shown in plantarflexion;

FIG. 22 is a lateral view of the article of footwear of FIG. 1 shown in dorsiflexion;

FIG. 23 is a perspective view of the compressive fitting system of FIG. 1 with the upper member and strand guide shown in a neutral position in solid lines, with the upper member and the strand guide shown in a compressed position in phantom lines, and with the tensioning system shown with broken lines;

FIG. 24 is a lateral view of the article of footwear according to additional embodiments of the present disclosure;

FIG. 25 is a medial view of the article of footwear of FIG. 24;

FIGS. 26 and 27 are rear views of the article of footwear and fitting system according to additional embodiments of the present disclosure, wherein FIG. 26 shows the fitting system being tightened and FIG. 27 shows the fitting system being loosened;

FIG. 28 is a lateral view of the article of footwear according to additional embodiments of the present disclosure; and

FIG. 29 is a perspective view of a tensioning system of the compressive fitting system of the article of footwear of FIG. 28.

#### DETAILED DESCRIPTION

The following discussion and accompanying figures disclose a variety of concepts relating to articles of footwear with fitting systems that adjustably fit the footwear to the wearer's foot. Stated differently, the fitting systems can tighten and secure the footwear to the foot, and the fitting systems can loosen and release the footwear from the foot as will be discussed in detail. The fitting systems can compress the footwear against the wearer's foot in some embodiments so as to closely and comfortably conform the footwear to the foot. The fitting systems can also adjust the fit of the footwear while the wearer's foot moves and flexes while walking, running, jumping, or otherwise moving. As a result, the footwear can be very comfortable to wear, the footwear can enhance the wearer's ability to run and jump, and the footwear can provide additional benefits that will be discussed in detail below.

FIGS. 1 through 3 illustrate exemplary embodiments of an article of footwear 100, also referred to simply as footwear 100. In some embodiments, article of footwear 100 may include a sole structure 110 and an upper 120. Although footwear 100 is illustrated as having a general configuration suitable for running, concepts associated with footwear 100 may also be applied to a variety of other athletic footwear types, including baseball shoes, basketball shoes, cycling shoes, football shoes, tennis shoes, soccer shoes, training shoes, walking shoes, and hiking boots, for example. The concepts may also be applied to footwear types that are generally considered to be non-athletic, including dress shoes, loafers, sandals, and work boots. Accordingly, the concepts disclosed with respect to footwear 100 may be applied to a wide variety of footwear types.

For reference purposes, footwear 100 may be divided into three general regions, namely, a forefoot region 101, a midfoot region 102, and a heel region 103 as shown in FIGS. 1 and 2. These regions 101, 102, 103 can be spaced apart generally along a longitudinal axis X of footwear 100. Forefoot region 101 generally includes portions of footwear 100 corresponding with the toes and the joints connecting the metatarsals with the phalanges. Midfoot region 102 generally includes portions of footwear 100 corresponding with an arch area of the foot. Heel region 103 generally corresponds with rear portions of the foot, including the calcaneus bone. Footwear 100 also includes a lateral side 104 and a medial side 105, which are spaced on opposite sides of axis X, and which extend through each of forefoot region 101, midfoot region 102, and heel region 103 and correspond with opposite sides of footwear 100. More particularly, lateral side 104 corresponds with an outside area of the foot that faces away from the other foot, and medial side 105 corresponds with an inside area of the foot that faces toward the other foot. Forefoot region 101, midfoot region 102, and heel region 103 and lateral side 104, medial side 105 are not intended to demarcate precise areas of footwear 100. Rather, forefoot region 101, midfoot region 102, and heel region 103 and lateral side

**104**, medial side **105** are intended to represent general areas of footwear **100** to aid in the following discussion. Additionally, while the terms forefoot region **101**, midfoot region **102**, heel region **103**, lateral side **104**, and medial side **105** can be applied to footwear **100**, these terms can also indicate corresponding areas of the sole structure **110**, the upper **120**, and individual elements of these structures.

Exemplary embodiments of sole structure **110** are shown FIGS. **1-3**. Sole structure **110** is secured to upper **120** and extends between the foot and the ground when footwear **100** is worn. Thus, sole structure **110** can define a ground engaging surface **114**. Sole structure **110** can also include an upper engaging surface **113** that is coupled to sole structure **110**. Furthermore, sole structure **110** can include a side surface **115** that extends between ground engaging surface **114** and upper engaging surface **113**. Side surface **115** can define a periphery of sole structure **110**. As will be discussed, sole structure **110** can be flexible. For example, sole structure **110** can bend along any suitable axis when the wearer runs, jumps, or otherwise moves the foot within footwear **100**.

In some embodiments, the sole structure **110** can include a midsole **111** and an outsole **112**. In additional embodiments, the sole structure **110** can include a sockliner that is disposed within upper **120** to extend under a lower surface of the foot and to enhance the comfort of footwear **100**.

Midsole **111** can define upper engaging surface **113** and can be secured to a lower surface of upper **120**. Midsole **111** may be formed from a compressible polymer foam element, such as a polyurethane or ethylvinylacetate foam, that attenuates ground reaction forces to provide cushioning when compressed between the foot and the ground during walking, running, or other ambulatory activities. In additional embodiments, midsole **111** may incorporate plates, moderators, fluid-filled chambers, lasting elements, or motion control members that further attenuate forces, enhance stability, or influence the motions of the foot.

As shown in FIG. **3**, upper engaging surface **113** can include one or more projections **117** that extend generally toward upper **120**. For instance, projections **117** can be contoured to support and/or shape corresponding portions of upper **120**. Projections **117** in FIG. **3**, for example, are positioned about heel region **103**, medial region **102**, and forefoot region **101**. Projections **117** can also be shaped to cushion and/or resist medial, lateral, rearward, and forward movements of the wearer's foot within upper **120**.

Outsole **112** can be secured to a lower surface of midsole **111** and may be formed from a wear-resistant rubber material that is textured to impart traction. Outsole **112** can also include a plurality of durable pads that are spaced apart on the lower surface of midsole **111**. Thus, outsole **112** can at least partially define ground engaging surface **114** to provide traction to footwear **100**.

Sole assembly **110** can also include a recess **116**. For instance, recess **116** can extend upward from ground engaging surface **114**. Recess **116** can have any suitable shape and dimension. Recess **116** can extend from ground engaging surface **114** and into outsole **112**. In some embodiments, recess **116** can also extend from ground engaging surface **114**, through outsole **112**, and into midsole **111**. Features of recess **116** will be discussed in further detail below.

Embodiments of upper **120** are also shown in FIGS. **1-3**. Upper **120** can define a void **122** within footwear **100** for receiving and securing a foot relative to sole structure **110**. Upper **120** can be shaped to accommodate the wearer's foot and can extend along a lateral side of the foot, along a medial side of the foot, over the foot, around the heel, and under the foot in some embodiments.

Access to the void **122** can be provided by an ankle opening **121** located in at least heel region **103**. The size of ankle opening **121** can be defined by a rim **123** through which the wearer's foot enters and exits upper **120**.

In some embodiments, upper **120** can be made from a lightweight and flexible material. For instance, upper **120** can be made from fabric, breathable mesh, or other suitable material.

As shown in FIGS. **1-4**, article of footwear **100** can further include a fitting system **130**. Fitting system **130** can secure footwear **100** to the wearer's foot as will be discussed. For instance, fitting system **130** can allow the wearer to selectively tighten footwear **100** to the wearer's foot, and fitting system **130** can allow the wearer to selectively loosen footwear **100** from the wearer's foot. Fitting system **130** can also automatically adjust the fit of the footwear **100** such that footwear **100** comfortably conforms to the wearer's foot as the foot flexes, extends, and moves within upper **120**.

It will be appreciated that fitting system **130** illustrated in FIGS. **1-4** and described below are merely exemplary embodiments of the present disclosure. Thus, fitting system **130** could vary in many ways without departing from the scope of the present disclosure.

Embodiments of fitting system **130** will now be discussed in detail. In some embodiments, fitting system **130** can generally include an upper member **132**, a strand guide **134**, and a tensioning system **136** as shown in FIGS. **1-4**. Upper member **132** can be disposed on, supported by, coupled to, and/or attached to upper **120**. Strand guide **134** can be disposed on, supported by, coupled to, and/or attached to sole structure **110**. Moreover, tensioning system **136** can extend between and operably couple upper member **132** and strand guide **134**. As will be discussed, tension within tensioning system **136** can cause upper member **132** and strand guide **134** to be biased toward each other to fit footwear **100** to the wearer's foot.

In some embodiments, fitting system **130** can further include an adjustment device **135** that allows tension in the tensioning system **136** to be selectively adjusted by the wearer. Accordingly, adjustment device **135** can allow the user to selectively adjust the fit or the compressive load applied by the fitting system **130** to the wearer's foot as will be discussed.

Upper member **132** can have any suitable shape and size. For instance, as shown in FIGS. **1-4**, upper member **132** can include a relatively thin panel **140** of flexible material. In some embodiments, panel **140** can include a knitted or woven fabric, leather, or other suitable material. Panel **140** can also be supported in any suitable position relative to upper **120**. For instance, panel **140** can overlap midfoot region **102** of upper **120** and can extend between medial side **105** and lateral side **104** of upper **120**. Panel **140** can also be disposed immediately forward of ankle opening **121** and can be substantially centered with respect to ankle opening **121**. As such, panel **140** can effectively distribute loads over the midfoot region of the wearer's foot.

It will be appreciated that although panel **140** covers an outer surface of upper **120** and is exposed in the illustrated embodiments, panel **140** could be differently arranged with respect to upper **120**. For example, panel **140** could be overlapped by portions of upper **120**. Panel **140** also could be at least partially enclosed by upper **120** in some embodiments.

As shown in the embodiments of FIG. **3**, panel **140** can have a main body **142** and at least one projection that extends from main body **142**. More specifically, panel **140** can include a forward lateral projection **144**, a rear lateral projection **146**, a forward medial projection **148**, and a rear medial projection

150. Projection 144 and projection 146 can extend from main body 142 toward lateral side 104 of footwear 100. Projection 148 and projection 150 can extend from main body 142 toward medial side 105. Projection 144 and projection 146 can also be spaced apart longitudinally along axis X of footwear 100. Likewise projection 148 and projection 150 can be similarly spaced longitudinally along axis X. Accordingly, panel 140 can be generally butterfly-shaped and symmetrical, and panel 140 can be substantially centered over footwear 100.

Embodiments of strand guide 134 will now be discussed. Strand guide 134 can also have any suitable shape and size. Strand guide 134 can also be coupled to sole structure 110 and can extend through sole structure 110. Moreover, strand guide 134 can be flexible and can flex in concert with sole structure 110. As such, flexure of strand guide 134 can cause sole structure 110 to flex. Also, flexure of sole structure 110 can cause strand guide 134 to flex. Furthermore, strand guide 134 can be coupled to tensioning system 136 and can couple tensioning system to sole structure 110. As such, tension of tensioning system 136 can cause flexure of strand guide 134. Still further, flexure of strand guide 134 can cause a change in tension of tensioning system 136. Strand guide 134 can further reinforce sole structure 110 and distribute forces of the tensioning system 136 on sole structure 110. As such, sole structure 110 is unlikely to be damaged by tensioning system 136. Moreover, strand guide 134 can guide movement of tensioning system 136 relative to sole structure 110 in some embodiments.

As shown in FIGS. 3-6, strand guide 134 can include a longitudinal member 152 with at least one transverse member extending transversely from longitudinal member 152. Also, strand guide 134 can include a plurality of transverse members. For example, strand guide 134 can include a first forward lateral transverse member 154, a second forward lateral transverse member 156, a first rear lateral transverse member 158, and a second rear lateral transverse member 160 that each extend transversely from longitudinal member 152. Strand guide 134 can further include a first forward medial transverse member 162, a second forward medial transverse member 164, a first rear medial transverse member 166, and a second rear medial transverse member 168 that each extend transversely from longitudinal member 152. Transverse member 162, transverse member 164, transverse member 166, and transverse member 168 can each extend in a direction opposite that of transverse member 154, transverse member 156, transverse member 158, and transverse member 160. As shown in the illustrated embodiments, first forward lateral transverse member 154 and first forward medial transverse member 162 can be substantially aligned. Likewise, second forward lateral transverse member 156 and second forward medial transverse member 164 can be substantially aligned, first rear lateral transverse member 158 and first rear medial transverse member 166 can be substantially aligned, and second rear lateral transverse member 160 and second rear medial transverse member 168 can be substantially aligned. Moreover, an end 170 of longitudinal member 152 can extend from second rear lateral transverse member 160 and second rear medial transverse member 168.

One or more of transverse member 154, transverse member 156, transverse member 158, transverse member 160, transverse member 162, transverse member 164, transverse member 166, and transverse member 168 can be integrally attached to longitudinal member 152. Also, strand guide 134 can be made out of any suitable material, such as polymeric or metallic material. Additionally, strand guide 134 can resiliently flexibly as represented in FIGS. 13, 17-20, and 23. For example, as shown in FIG. 23, strand guide 134 is shown in a

neutral position in solid lines, and strand guide 134 is shown in a resiliently flexed position in phantom lines. In some embodiments, strand guide 134 can be resiliently flexed or bent from the neutral position to the flexed position, and upon removal of the bending load, the strand guide 134 can resiliently recover back to the neutral position.

As shown in the embodiments of FIG. 5, longitudinal member 152 can be curved longitudinally. Also, as shown in FIG. 5, transverse member 154, transverse member 156, transverse member 158, transverse member 160, transverse member 162, transverse member 164, transverse member 166, and transverse member 168 can extend transversely from longitudinal member 152 at a respective angle, one of which is indicated at reference numeral 169. It will be appreciated that angles 169 between longitudinal member 152 and each of transverse members can have any suitable value.

Furthermore, strand guide 134 can include one or more upturned ends 176. For example, transverse member 154, transverse member 156, transverse member 158, transverse member 160, transverse member 162, transverse member 164, transverse member 168, and end 170 can each include a respective upturned end 176, which is spaced from longitudinal member 152.

Still further, as shown in FIGS. 5, 6 and 11-13, strand guide 134 can define a guide surface 174. Guide surface 174 can be shaped, sized, and otherwise configured to receive tensioning system 136 to thereby operably couple the tensioning system 136 to strand guide 134. For example, guide surface 174 can be defined by an open groove, a hollow tube, or other aperture included on strand guide 134. In the illustrated embodiments, for example, guide surface 174 is defined by a groove on an underside of strand guide 134. The guide surface 174 can be contoured and concave in cross section. For example, guide surface 174 can be U-shaped in cross section as shown in FIG. 6. Moreover, guide surface 174 can extend and branch continuously along longitudinal member 152, transverse members 154, transverse member 156, transverse member 158, transverse member 160, transverse member 162, transverse member 164, transverse member 166, and transverse member 168.

Strand guide 134 can be operably coupled and supported by sole structure 110 in any suitable fashion. For example, as shown in FIG. 3, strand guide 134 can be received within recess 116 of sole structure 110. Thus, in some embodiments, recess 116 can be shaped and sized to match the shape and size of strand guide 134. Also, in some embodiments, strand guide 134 can be held within recess 116 via friction, via an interference fit, via fasteners, or other suitable attachment device. Thus, strand guide 134 can be exposed through the ground engaging surface 114. In additional embodiments, strand guide 134 can be substantially enclosed within sole structure 110. For example, ground engaging surface 114 can substantially cover strand guide 134, and ends 176 of strand guide 134 can be exposed through respective openings in sole structure 110. Ends 176 can extend slightly outward from sole structure 110 or can be disposed inward relative to sole structure 110. The position of ends 176 can also be dependent on the anatomy of the wearer's foot, the size of the sole structure 110, or other factors.

Additionally, strand guide 134 can be disposed relative to sole structure 110 in any suitable location when coupled to sole structure 110. As shown in the embodiment of FIG. 5 where sole structure 110 is shown in phantom, strand guide 134 can be substantially centered on sole structure 110 and disposed such that longitudinal member 152 can extend generally along longitudinal axis X. Also, lateral transverse member 154, lateral transverse member 156, lateral trans-

verse member 158, and lateral transverse member 160 can extend laterally toward lateral side 104. Medial transverse member 162, medial transverse member 164, medial transverse member 166, and medial transverse member 168 can extend medially toward medial side 105. Uprturned ends 176 of transverse member 154, transverse member 156, transverse member 158, and transverse member 160 can be disposed adjacent side surface 115 of sole structure 110. Also, ends 176 can be exposed through sole openings 119 that are defined by side surface 115 of sole structure 110. Uprturned ends 176 can be turned upward slightly towards upper 120 as shown.

Embodiments of tensioning system 136 will now be discussed with reference to FIGS. 1-4 and 7. As mentioned above, tensioning system 136 can operably couple upper member 132 and strand guide 134. As such, upper member 132 can be biased toward strand guide 134 to fit article of footwear 100 to the wearer's foot. Moreover, tensioning system 136 can allow footwear 100 to adjust to the wearer's foot when it flexes, extends, and moves within upper 120. Tensioning system 136 can also be highly flexible and moveable relative to upper 120 and/or sole structure 110 to thereby accommodate the high degree movement of the wearer's foot.

Tensioning system 136 can include one or more flexible strands. In some embodiments, tensioning system 136 can include a first strand 190 and a second strand 196. The strand 190 and strand 196 can be a cable, a rope, a wire, a cord, braided wires, a yarn, a monofilament, a composite filament including multiple wound or braided filaments, a chain, or other suitable elongate and flexible structures. Also, strand 190 and/or strand 196 can have a substantially fixed length. In additional embodiments, strand 190 and/or strand 196 can be resiliently stretchable and extendable in length. However, it will be appreciated that tensioning system 136 can include any suitable number of strands and/or tensioning system 136 can include alternative structure without departing from the scope of the present disclosure.

Tensioning system 136 can be arranged in any suitable fashion with respect to upper 120, sole structure 110, and strand guide 134. Stated differently, strand 190 and strand 196 can extend over, through, and under any suitable portion of upper 120, sole structure 110, and strand guide 134.

Tensioning system 136 can be cooperatively defined by first strand 190 and second strand 196. For purposes of discussion, the tensioning system 136 will be discussed as being divided into a plurality of portions, sections, or segments. For example, tensioning system 136 can include a central portion 184, a medial portion 182, and a lateral portion 180 as indicated in FIGS. 4 and 7. Central portion 184 of tensioning system 136 can be received and guided by strand guide 134 for movement that is directed substantially parallel to the ground engaging surface 114. Medial portion 182 can branch from central portion 184 and can be connected to the upper member 132 on the medial side 105 of footwear 100. Lateral portion 180 can branch from central portion 184 and can be connected to upper member 132 on the lateral side 104 of footwear 100. First strand 190 and second strand 196 can collectively define each of central portion 184, medial portion 182, and lateral portion 180 of tensioning system 136 in some embodiments.

Tensioning system 136 can also be connected to heel region 103 of footwear 100 on the upper 120 and/or sole structure 110. For example, a tail portion 290 of tensioning system 136 can be attached to heel region 103 and can be attached to central portion 184 of tensioning system 136. In some embodiments, tail portion 290 can be fixedly attached to

heel region 103. In other embodiments, tail portion 290 can be removeably attached to heel region 103.

First strand 190 will now be discussed in greater detail. First strand 192 can be divided longitudinally into a plurality of sections, portions, divisions, or segments. The following discussion of the different longitudinal sections of the first strand 190 is merely exemplary, and it will be appreciated that first strand 192 can be divided longitudinally into any number of sections.

For example, in the embodiments shown in FIGS. 3, 4, and 7, a first end 192 of first strand 190 can extend from heel region 103 and vertically downward. A first horizontal section 250 of first strand 190 can be received in end 170 of longitudinal member 152 and can continuously extend forward along longitudinal member 152 toward forefoot region 101. A second horizontal section 252 of first strand 190 can extend along first forward lateral transverse member 154 toward the lateral side 104. From end 176 of transverse member 154, a third vertical section 254 of first strand 190 can extend vertically upward toward upper 120 and upper member 132 to connect the first strand 190 to forward lateral projection 144 of upper member 132. A fourth vertical section 256 of first strand 190 can extend back vertically downward from forward lateral projection 144 toward sole structure 110. A fifth horizontal section 258 can extend from end 176 of second forward lateral transverse member 156, first strand 190 can cross over longitudinal member 152, and a sixth horizontal section 260 of first strand 190 can extend along second forward medial transverse member 164. Moreover, a seventh vertical section 262 of first strand 190 can extend from end 176 of transverse member 164 upward toward upper 120 and upper member 132 to connect the first strand 190 to forward medial projection 148 of upper member 132. An eighth vertical section 264 can extend back vertically downward from forward medial projection 148 toward sole structure 110. A ninth horizontal section 265 can extend along first forward medial transverse member 162 toward longitudinal member 152. Additionally, a tenth horizontal section 266 can extend longitudinally along longitudinal member 152. From end 176 of longitudinal member 152, a second end 194 of first strand 190 can extend upward and terminate at heel region 103.

It will be appreciated that section 250, section 266, section 252, section 258, section 260, and section 265 can cooperate to at least partially define the central portion 184 of the tensioning system 136 in the illustrated embodiments. It will also be appreciated that section 254 and section 256 can cooperate to at least partially define the lateral portion 180 of tensioning system 136. Moreover, section 262 and section 264 can cooperate to at least partially define the medial portion 182 of tensioning system 136.

Furthermore, section 254 and section 256 can be disposed at an angle relative to each other and can be arranged in an inverted "V" shape as shown in FIGS. 3, 4, and 7. Likewise, section 262 and section 264 can also be disposed at an angle relative to each other and can be arranged in an inverted "V" shape.

Second strand 196 will now be discussed in greater detail. Second strand 196 can be considered to have a plurality of sections, portions, divisions, or segments. As discussed above with respect to first strand 190, the second strand 196 can be divided longitudinally into any number of sections.

Specifically, in the embodiments shown in FIGS. 3, 4, and 7, a first end 198 of second strand 196 can extend from heel region 103 and vertically downward. A first horizontal section 270 of second strand 196 can be received in end 170 of longitudinal member 152 and can continuously extend forward along longitudinal member 152 toward forefoot region

## 11

101. A second horizontal section 272 of second strand 196 can extend along first rear lateral transverse member 158 toward the lateral side 104. From end 176 of transverse member 158, a third vertical section 274 of second strand 196 can extend vertically upward toward upper 120 and upper member 132 to connect the second strand 196 to rear lateral projection 146 of upper member 132. A fourth vertical section 276 of second strand 196 can extend back vertically downward from rear lateral projection 146 toward sole structure 110. A fifth horizontal section 278 can extend from end 176 of second rear lateral transverse member 160, second strand 196 can cross over longitudinal member 152, and a sixth horizontal section 280 of second strand 196 can extend along second rear medial transverse member 168. Moreover, a seventh vertical section 282 of second strand 196 can extend from end 176 of transverse member 168 upward toward upper 120 and upper member 132 to connect the second strand 196 to rear medial projection 150 of upper member 132. An eighth vertical section 284 can extend back vertically downward from rear medial projection 150 toward sole structure 110. A ninth horizontal section 286 can extend along first rear medial transverse member 166 toward longitudinal member 152. Additionally, a tenth horizontal section 288 can extend longitudinally along longitudinal member 152. From end 176 of longitudinal member 152, a second end 200 of second strand 196 can extend upward and terminate at heel region 103.

It will be appreciated that section 270, section 272, section 278, section 286, section 280, and section 288 can cooperate to at least partially define the central portion 184 of the tensioning system 136 in the illustrated embodiments. It will also be appreciated that section 274 and section 276 can cooperate to at least partially define the lateral portion 180 of tensioning system 136. Moreover, section 284 and section 282 can cooperate to at least partially define the medial portion 182 of tensioning system 136.

Furthermore, section 274 and section 276 can be disposed at an angle relative to each other and can be arranged in an inverted "V" shape as shown in FIGS. 3, 4, and 7. Likewise, section 284 and section 282 can also be disposed at an angle relative to each other and can be arranged in an inverted "V" shape.

It will be appreciated that strand 190 and strand 196 could be routed in any suitable way to couple upper member 132 and strand guide 134. It will also be appreciated that first strand 190 and second strand 196 could be braided together or otherwise joined together in some embodiments. Moreover, it will be appreciated that tensioning system 136 could include more or less strands than those in the illustrated embodiments.

Strand 190 and strand 196 can be attached to upper member 132 in any suitable fashion. For example, upper member 132 can include a plurality of fasteners 199 for attaching strand 190 and/or strand 196 to upper member 132. The fasteners 199 can be disposed on respective ones of projection 144, projection 146, projection 148, and projection 150. The fasteners 199 can be of any suitable type, such as pegs, to which the strand 190 and strand 196 are attached. In additional embodiments, fasteners 199 can include eyelets, grommets, hooks, or other fastening devices for attaching to the strand 190 and/or strand 196. Fasteners 199 could also be attached to strand 190 or strand 196 for attaching to upper member 132.

For example, as shown in FIGS. 8, 9, and 10 a vertex 205 of strand 190 can be defined between section 254 and section 256, and vertex 205 can turn over a base 203 of fastener 199 to attach strand 190 to projection 144 of upper member 132. Fasteners 199 can also include an enlarged head 207 that can secure vertex 205 to upper member 132. First strand 190 can

## 12

be similarly attached at projection 148 of upper member 132, and second strand 196 can be similarly attached at projection 146 and projection 150 of upper member 132.

Also, as shown in FIGS. 8 and 9, first strand 190 can slide longitudinally over base 203 of fastener 199. By comparing FIG. 8 and FIG. 9, it will be apparent that strand 190 can slide in either direction over base 203 of fastener 199 with respect to the longitudinal axis of strand 190. It will be appreciated that second strand 196 can be similarly attached to the other fasteners 199. Thus, strand 190 and strand 196 can be moveably attached to upper member 132 at respective locations defined by fasteners 199. Stated differently, strand 190 can slide along the longitudinal axis of strand 190 relative to upper member 132 and, yet, still remain attached to upper member 132. Likewise, strand 196 can slide along the longitudinal axis of strand 196 relative to upper member 132 and, yet, still remain attached to upper member 132.

Moreover, as shown in FIG. 10, tension of first strand 190 can increase to pull upper member 132 toward sole structure 110 and strand guide 134. Stated differently, the first strand 190 can pull upper member 132 from the position shown in phantom in FIG. 10 to the position shown in solid lines in FIG. 10. In contrast, tension of first strand 190 can decrease to allow upper member 132 to move away from sole structure 110 and strand guide 134. It will also be appreciated that tension of second strand 196 can increase to similarly pull upper member 132 toward sole structure 110 and strand guide 134. Furthermore, it will be appreciated that tension of second strand 196 can decrease to allow upper member 132 to move away from sole structure 110 and strand guide 134. Accordingly, increasing tension in tensioning system 136 can pull the upper member 132 and the upper 120 toward the wearer's foot, and decreasing tension in tensioning system 136 can release the upper member 132 and the upper 120 from the wearer's foot.

Additionally, strand 190 and strand 196 can be attached to strand guide 134 in any suitable fashion. For example, strand 190 and strand 196 can be received by guide surface 174 of strand guide 134 and can be substantially aligned with respective portions of strand guide 134.

Also, as shown in FIGS. 11 and 12, strand 190 can abut and slide across guide surface 174 of strand guide 134. By comparing FIGS. 11 and 12, it will be apparent that strand 190 can slide in both longitudinal directions across guide surface 174. It will be appreciated that second strand 196 can similarly slide across respective portions of guide surface 174. It will also be apparent that the recessed, U-shaped contour of guide surface 174 can direct and guide strand 190 and strand 196 toward the inner apex of guide surface 174. Accordingly, the guide surface 174 can help retain strand 190 and strand 196 against the guide surface 174 of strand guide 136.

Furthermore, as shown in FIG. 13, strand guide 134 can flex as a result of changing tension in strand 190. For example, strand guide 134 can bend resiliently between a neutral position shown in solid lines in FIG. 13 and a flexed position shown in phantom in FIG. 13. It will be appreciated that second strand 196 can similarly cause flexion of respective portions of strand guide 134.

As represented in the exemplary embodiment of FIG. 23, the upper member 132 and the strand guide 134 are shown in a neutral position in solid lines. The upper member 132 and strand guide 134 are also shown in a flexed position in phantom in FIG. 23. The tensioning system 136 is shown with broken lines for purposes of clarity; however, it will be apparent from the above description that tensioning system 136 can bias upper member 132 generally toward strand guide 134. As described above with respect to FIGS. 10 and 13, changing

tension in the tensioning system 136 can cause movement of the upper member 132 and the strand guide 134 between the neutral and flexed position. Assuming that the upper member 132 and strand guide 134 are in the neutral position, an increase in tension in tensioning system 136 can pull upper member 132 toward the strand guide 134 and, thus, the sole structure 110. At the same time, ends 176 of strand guide 134 can rotate inward and upward toward upper member 132. Accordingly, upper member 132 and strand guide 134 can compress toward each other in multiple directions and, as a result, the fitting system 130 can cause the footwear 100 to fit tighter to the wearer's foot. It will be appreciated that reducing tension in tensioning system 136 can allow upper member 132 and strand guide 134 to move away from each other for looser fitting footwear 100.

As mentioned above, strand 190 and strand 196 can slide longitudinally and adjust with respect to upper member 132 and strand guide 134. Thus, tensioning system 136 can adjust to changes in tension while the wearer's foot flexes and moves within footwear 100. Stated differently, the wearer's foot may flex so as to increase in volume and push outward on some portions of the inner surface of upper 120. These forces can, for example, push outward on upper member 132 to increase tension in tensioning system 136. The tensioning system 136 can slide relative to upper member 132 to accommodate such changes in tension. Likewise, running, jumping, and other activities can involve flexure of the sole structure 110; however, strand guide 134 can flex in concert with sole structure 110, and tensioning system 136 can slide along strand guide 134 to accommodate such flexure. As such, the fit of footwear 100 can automatically adjust to keep the wearer's foot comfortable and properly supported during such movement.

More specifically, as shown in FIGS. 3, 4, 7, 17, and 18, strand 190 can define a section height 268. For example, as shown in FIG. 3, section 254 has a section height 268 defined from the respective vertex 205, where the strand 190 is coupled to the upper member 132, to the adjacent horizontal section 252, where the strand 190 is coupled to the strand guide 134. Stated differently, the section 254 can freely extend between upper member 132 and strand guide 134 along the section height 268. Section 264 defines a similar section height 268 as shown in FIG. 4. Similarly, section 256 and section 262 can also each define a respective section height 268. Moreover, strand 196 can define similar section heights 268 for section 274, section 276, section 282, and section 284.

It will be appreciated that section height 268 of the sections can adjust due to changing tension of strand 190 and strand 196. Section heights 268 can also change as the upper member 132 moves toward and away from strand guide 134.

Section heights 268 can further change as the strand guide 134 flexes. For example, as shown in FIGS. 17 and 18, footwear 100 can flex and bend in the fore/aft direction to flex strand guide 134. As a result, tensioning system 136 can pull upper member 132 toward strand guide 134. Stated differently, longitudinal member 152 of strand guide 134 can have a longitudinal length 299 as shown in FIG. 17, and longitudinal member 152 can be substantially straight along the length 299. Flexure of the strand guide 134 can increase the curvature of the longitudinal member 152 along the length 299 as shown in FIG. 18. Strand guide 134 can, thus, pull on the strand 190 and/or the strand 196 due to this flexure. Strand 190 and/or strand 196 can accommodate this change in curvature by sliding over fasteners 199 and ends 176. As such, section height 268 can be smaller in the flexed position of

FIG. 18 as compared to the neutral position of FIG. 17. Also, upper member 132 can be pulled toward strand guide 134 and toward the wearer's foot.

Similarly, footwear 100 can flex in the medial/aft direction as shown in FIGS. 19 and 20. As a result, tensioning system 136 can pull upper member 132 toward strand guide 134. Stated differently, strand guide 134 can define a transverse length 298 defined between opposing ends 176, and strand guide 134 can be substantially straight along the length 298 as shown in FIG. 19. Flexure of the strand guide 134 can increase the curvature of the strand guide 134 along the length 298 as shown in FIG. 20. Strand guide 134 can, thus, pull on the strand 190 and/or the strand 196 due to this flexure. Strand 190 and/or strand 196 can accommodate this change in curvature by sliding over fasteners 199 and ends 176. As such, section height 268 can be smaller in the flexed position of FIG. 20 as compared to the neutral position of FIG. 19. Also, upper member 132 can be pulled toward strand 134 and toward the wearer's foot.

As mentioned above, tensioning system 136 can be attached to heel region 103 of upper 120. Specifically, first end 192 and second end 194 of first strand 190 can be attached to heel region 103. First end 198 and second end 200 of second strand 196 can be attached to heel region 103 of upper 120. It will be appreciated, however, that any portion of strand 190 and/or strand 196 can be attached to heel region 103 using any suitable means.

Tensioning system 136 can, thus, be attached to heel region 103 and to upper member 132 at the medial side 105 and lateral side 104 while also extending longitudinally and transversely across sole structure 110. This routing of tensioning system 136 can allow for a high degree of adjustability of footwear 100 relative to the wearer's foot.

Moreover, as mentioned above and as shown in FIGS. 1-4, fitting system 130 can include an adjustment device 135 that allows for selective adjustment of tension within strand 190 and/or strand 196. For example, in the illustrated embodiments, adjustment device 135 can include a fastening portion 137 of tensioning system 136 and a retainer 138 that is included on at least one of upper 120 and sole structure 110. More specifically, first and/or second strand 190, 196 can define the fastening portion 137 of tensioning system 136, and fastening portion 137 can selectively attach or fasten to retainer 138 in one or more fastened configurations represented in FIGS. 14 and 15. Fastening portion 137 can also be configured to detach or unfasten from retainer 138 in an unfastened configuration represented in FIG. 16.

It will be appreciated that by moving fastening portion 137 between the fastened and unfastened configurations, tension of tensioning system 136 can be adjusted. As a result, the biasing or compression level of upper member 132 toward strand guide 134 can be adjusted.

In some embodiments, ends 192, 194, 198, 200 of strands 190, 196 can be attached to a hook 201 to define the fastening portion 137 of tensioning system 136. Also, as shown in FIGS. 1, 2, and 3, retainer 138 can include a body 202 that is supported by upper 120. Body 202 can also be supported by sole structure 110 in some embodiments. Body 202 can be substantially rigid and can be incorporated in a heel counter of upper 120 in some embodiments. Body 202 can be made from rigid, relative lightweight material, such as hard plastic. Body 202 can also have ribs, honeycomb, or other projections that increase rigidity, strength, or other structural support.

Body 202 can further include one or more retaining features 204 as shown in FIGS. 3 and 4. For example, body 202 can include two or more openings 206 that are arranged in a



## 15

vertically-extending row. Hook **201** can be received and retained in any of the openings **206**.

In a first fastened configuration shown in FIG. **14**, hook **201** is received in an opening **206** of retainer **138**. In a second fastened configuration shown in FIG. **15**, hook **201** is received in an opening **206** located further downward on body **202**. In an unfastened configuration shown in FIG. **16**, hook **201** is unfastened from retainer **138**.

To move tensioning system **136** from unfastened configuration of FIG. **16** to first fastened configuration of FIG. **14**, wearer can pull hook **201** upward in the direction of arrow **211**. This can consequently pull and increase tension in first and second strands **190**, **196** to bias and compress upper member **132** toward strand guide **134** in the direction of arrows **213**. Also, midfoot region **102**, lateral side **104**, and/or medial side **105** of upper **120** can more closely conform to the wearer's foot due to such tightening of fitting system **130**. Likewise, such loading of strand guide **134** can transfer to sole structure **110** to flex sole structure **110** and conform sole structure **110** to the sole of the wearer's foot.

If the wearer so chooses, fitting system **130** can be loosened somewhat by moving the tensioning system **136** from the first fastened configuration of FIG. **14** to the second fastened configuration of FIG. **15**. Specifically, hook **201** can be moved downward in the direction of arrow **217** in FIG. **15**. As a consequence, tension can be reduced in tensioning system **136**. Also, upper member **132** can move slightly away from sole structure **110** and strand guide **134** in the direction of arrows **219**.

Moreover, to further loosen fitting system **130**, the wearer can unfasten the hook **201** from retainer **138** as shown in FIG. **16**. The wearer may wish to move fitting system **130** to the unfastened configuration to insert foot into void **122** or to remove foot from void **122** of upper **120**.

Moreover, FIGS. **21** and **22** illustrate how fitting system **130** can automatically adjust the fit of footwear **100** on the wearer's foot during flexion, extension or other movement of the wearer's foot and/or due to impact with the ground surface. FIG. **21** can represent the position of the wearer's foot and footwear **100** when thrusting forward from the ground surface when running or jumping. FIG. **22** can represent the wearer's foot and footwear **100** when the footwear **100** lands back on the ground surface.

For example, during plantarflexion of the wearer's foot represented in FIG. **21**, the wearer's ankle and midfoot can press upward to supply an input force to upper member **132** as represented by arrow **133**. As a result, tension in strands **190**, **196** can increase to draw strand guide **134** upward generally toward the sole of the wearer's foot. Specifically, as shown in FIG. **21**, a reaction load represented by arrow **291** can be transferred to strand guide **134** adjacent heel region **103**. In some embodiments, reaction load **291** can be a bending moment that causes end **170** of strand guide **134** to bend upward toward the sole and heel of the wearer's foot. Thus, the fitting system **130** can cause the sole structure **110** at heel region **103** to pull toward the wearer's foot.

In contrast, FIG. **22** illustrates footwear **100** during dorsiflexion of the wearer's foot. As shown, flexure of sole structure **110** can cause flexure of strand guide **134** as represented by curved arrows **292**, **293** in FIG. **22**. This flexure can increase tension in tensioning system **136** such that upper member **132** is pulled downward against the wearer's foot as represented by arrow **294** in FIG. **22**.

Accordingly, the fitting system **130** allows footwear **100** to comfortably fit and conform to the wearer's foot. Also, movements of the wearer's foot during running, jumping, flexure, and extension can cause the fitting system **130** to adjust.

## 16

Stated differently, fitting system **130** can tighten one or more areas of footwear **100** to the wearer's foot as the foot moves.

Turning now to FIGS. **24** and **25**, additional embodiments are illustrated. As shown, footwear can be substantially similar to the embodiments of FIGS. **1-23**. However, upper member **132** can additionally include a lateral heel projection **208** as shown in FIG. **24** and a medial heel projection **209** as shown in FIG. **25**. Heel projections **208**, **209** can extend generally toward heel region **103** of footwear.

Also, fitting system **130** can include a heel strap **212** that is supported by heel region of footwear. Moreover, tensioning system **136** can include a lateral heel strand **214** as shown in FIG. **24** and a medial heel strand **215** as shown in FIG. **25**. Lateral heel strand **214** can couple and extend between lateral heel projection **208** and one end of heel strap **212**, and medial heel strand **215** can couple and extend between medial heel projection **208** and the opposite end of heel strap **212**.

Thus, fitting system **130** can additionally pull heel region **103** into the wearer's heel due to movement of the wearer's foot and flexure of other areas of footwear. For example, plantarflexion of the foot can load the upper member **132** such that heel strands **214**, **215** pull heel strap **212** against wearer's heel. This can further allow footwear to fit comfortably and adjustably against wearer's foot.

Moreover, as shown in FIGS. **24** and **25**, footwear can include projections **216** that project outwardly from upper **120**. Projections **216** can be of any suitable type. For example, projections **216** can be raised strips of material, such as polymeric material. The projections **216** can extend in an aesthetically pleasing pattern. For example, projections **216** can extend in a serpentine pattern on upper **120**. Projections **216** can be disposed underneath respective ones of the inverted "V" of the tensioning system **136**. The tensioning system **136** can abut against projections **216** and can be supported against projections **216**. For instance, the tensioning system **136** can slide over projections **216**, and projections **216** can protect surrounding portions of upper **120** from abrasion or other damage. The projections **216** can also be configured to guide tensioning system **136**. For example, the projections **216** can include a groove or other opening that receives tensioning system **136** and keeps tensioning system **136** in a predetermined position relative to the upper **120**.

Referring now to FIGS. **26** and **27**, still further embodiments are illustrated. Footwear can be substantially similar to the embodiments discussed above. However, the adjustment device **135** can be different. For example, adjustment device **135** can include a spool **302** on which strands of tensioning system **136** can spool and unspool. Specifically, by rotating spool **302** in one direction, tensioning system **136** can advance toward spool **302**, and a portion of tensioning system **136** can gather onto spool **302** to increase tension in tensioning system **136**. By rotating spool **302** in the opposite direction, the portion of tensioning system **136** can unspool from spool **302** to decrease tension in tensioning system **136**.

Adjustment device **135** can further include a catch **304** that can retain spool **302** at a selected angular position. In some embodiments, for example, catch **304** can be a pawl that engages spokes extending from spool **302**. It will be appreciated that adjustment device **135** can include a release mechanism with which the user can release the catch **304** for unspooling tensioning system **136**. Also, in some embodiments, adjustment device **135** can incorporate one or more features disclosed in U.S. Pat. No. 5,934,599, issued on Aug. 10, 1999 to Hammerslag, U.S. Pat. No. 6,202,953, issued on Mar. 20, 2001 to Hammerslag, and/or U.S. Pat. No. 6,289,558, issued Sep. 18, 2001 to Hammerslag, each of which is hereby incorporated by reference in its entirety.

17

Moreover, as shown in FIGS. 26 and 27, strand guide 134 can be substantially enclosed within sole structure 110. Stated differently, ground engaging surface 114 can cover over strand guide 134. For example, sole structure 110 can include a cavity having a size and dimension conforming to that of strand guide 114, and strand guide 114 can be encapsulated within the cavity. Also, sole openings 139, such as through-holes, can expose ends 176 of strand guide 114 and/or allow passage of strands of tensioning system 136.

In still further embodiments, ends 176 can extend upward from sole structure 110 to be disposed on upper 120. For example, ends 176 can overlap and abut respective portions of upper 120.

Referring now to FIG. 28, additional embodiments of the article of footwear 100 are illustrated. As shown in FIG. 28, footwear 100 can be substantially similar to embodiments discussed above, except as noted herein.

For example, fitting system 130 can include an upper member 132 that is coupled to strands of tensioning system 136 in a different manner. More specifically, as shown in the illustrated embodiments, the upper member 132 can include one or more openings that receive the strands. As shown in FIG. 28, the upper member 132 can include a rear opening 401 and a forward opening 402. The rear opening 401 and forward opening 402 can receive at least one strand of the tensioning system 136 to thereby couple to the respective strand(s).

Also, as shown in FIG. 28, the adjustment device 135 can include a spool 302, similar to the embodiments of FIGS. 26 and 27. Also, portions of the strands of the tensioning system 136 can be enclosed within sole structure 110. The strands can extend out of the sole openings 139, similar to the embodiments discussed above in relation to FIGS. 26 and 27. It will be appreciated that the strand guide 134 can be similarly enclosed and embedded in sole structure 110, similar to the embodiments of FIGS. 26 and 27.

Additionally, as shown in FIGS. 28 and 29, tensioning system 136 can include first strand 190, second strand 196, as well as a heel strand 414. The first strand 190 and second strand 196 can be substantially similar to the embodiments discussed above. However, the heel strand 414 can extend between and can be coupled to the heel region 103 of the upper 120, the upper member 132 of the fitting system 130, and the sole structure 110.

More specifically, as shown in FIG. 29, the heel strand 414 can include a first horizontal section 470 that is coupled to the spool 302. The first horizontal section 470 can be spooled and unspooled from the spool 302. Also, the first horizontal section 470 can extend from the spool 302 across the lateral side 104 of the heel region 103 and can be received within the rear opening 401 to couple to the upper member 132. The heel strand 414 can also include a first vertical section 476 that extends from the rear opening 401 toward the sole structure 110. The first vertical section 476 can extend substantially parallel to the section 276 of the second strand 196. Also, the heel strand 414 can include a second horizontal section 479 that can be coupled to the strand guide 134 and that can extend substantially parallel to the section 278 and the section 280 of the second strand 196. Moreover, the heel strand 414 can include a second vertical section 482 that extends out of the sole structure 110 and that extends upward toward upper member 132 to couple to upper member 132 on the medial side 105 of the footwear 100. The second vertical section 482 can be substantially parallel to the section 282 of the strand 196. Furthermore, the heel strand 414 can include a third horizontal section 488 that extends back toward spool 302. The third horizontal section 488 can be spooled and unspooled from spool 302.

18

The heel strand 414 can function similar to the heel strap 212, strand 214, and strand 215 of the embodiments of FIGS. 24 and 25 to pull heel region 103 toward the wearer's heel. Tension in heel strand 414 can also be selectively adjusted by the wearer to change the amount of force applied by the heel region 103 onto the wearer's foot by rotating the spool 302 in either direction. Moreover, tension in the heel strand 414 can adjust in concert with the strand 190 and the strand 196 to adjust the fit of the footwear 100 according to the movements of the wearer's foot. Also, since heel strand 414 extends into sole structure 110, heel strand 414 can pull upper member 132, heel region 103, and sole structure 110 generally toward each other to compress the wearer's foot.

In summary, embodiments of fitting system 130 described above and shown in FIGS. 1-29 can allow footwear 100 to comfortably and securely fit to wearer's foot. The fit of footwear 100 can be quickly and easily adjusted by the wearer. Also, fit of the footwear 100 can automatically adjust during ambulatory movements of the wearer's foot. Accordingly, the footwear 100 can increase the wearer's ability to run, jump, or otherwise move.

While various embodiments of the present disclosure have been described, the description is intended to be exemplary, rather than limiting and it will be apparent to those of ordinary skill in the art that many more embodiments and implementations are possible that are within the scope of the present disclosure. Accordingly, the present disclosure is not to be restricted except in light of the attached claims and their equivalents. Also, various modifications and changes may be made within the scope of the attached claims.

We claim:

1. An article of footwear comprising:
  - an upper that defines a void for receiving a foot;
  - a flexible sole structure that is coupled to the upper and includes a ground-engaging surface; and
  - a fitting system that includes:
    - an upper member that is supported by the upper,
    - a strand guide that is supported by the sole structure, the strand guide being flexible and configured to flex in concert with the sole structure between a first position and a second position, the strand guide having a guide surface, and
    - a tensioning system with a flexible strand that is configured to bias the upper member toward the strand guide, the flexible strand having a first section coupled to the upper member and a second section extending through the sole structure, the second section abutting the guide surface and received within a groove formed in the ground-engaging surface of the sole structure, the second section configured to slide across the guide surface as a result of flexure of the strand guide between the first position and the second position, the first section and the upper member are configured to move relative to the sole structure as a result of sliding of the second section across the guide surface.

2. The article of footwear of claim 1, wherein the fitting system has a first configuration in which the flexible strand biases the upper member toward the sole structure at a first compression level, and wherein the fitting system has a second configuration in which the flexible strand biases the upper member toward the sole structure at a second compression level, the first compression level being greater than the second compression level.

3. The article of footwear of claim 2, wherein the fitting system further includes a retainer that is supported by at least one of the upper and the sole structure, the retainer including

19

a first retaining feature and a second retaining feature, wherein the tensioning system includes a fastening portion, the fastening portion retained by the first retaining feature in the first configuration, the fastening portion retained by the second retaining feature in the second configuration.

4. The article of footwear of claim 3, wherein the retainer is supported on a heel portion of the upper.

5. The article of footwear of claim 2, wherein the fitting system also includes a spool, and wherein the flexible strand is configured to spool on the spool and unspool from the spool to change the fitting system between the first configuration and the second configuration.

6. The article of footwear of claim 1, wherein the fitting system further includes a retainer supported by at least one of the upper and the sole structure, wherein the tensioning system includes a fastening portion, wherein the fitting system has a fastened configuration in which the fastening portion is fastened to the retainer to bias the upper member toward the sole support structure, and wherein the fitting system has an unfastened configuration in which the fastening portion is unfastened from the retainer.

7. The article of footwear of claim 1, wherein the article of footwear includes a medial side and a lateral side, wherein the upper member extends between the medial side and the lateral side, and wherein the flexible strand includes a medial portion that is attached to the upper member on the medial side, a lateral portion that is attached to the upper member on the lateral side, and a central portion that extends between the medial portion and the lateral portion of the flexible strand.

8. The article of footwear of claim 7, wherein the central portion of the flexible strand extends through the sole structure at least partially along a longitudinal axis of the article of footwear.

9. The article of footwear of claim 8, wherein the strand guide includes a longitudinal member that extends along the longitudinal axis of the article of footwear, wherein the central portion of the flexible strand is configured to slide across the longitudinal member of the strand guide.

10. The article of footwear of claim 9, wherein the strand guide also includes at least one transverse member that extends from the longitudinal member toward one of the medial side and the lateral side, and wherein the central portion of the flexible strand is configured to slide across both the longitudinal member and the at least one transverse member of the strand guide.

11. The article of footwear of claim 10, wherein the at least one transverse member includes a medial transverse member and a lateral transverse member, the medial transverse member extending from the longitudinal member toward the medial side, the lateral transverse member extending from the longitudinal member toward the lateral side, and wherein the central portion of the flexible strand is configured to slide across each of the longitudinal member, the medial transverse member, and the lateral transverse member.

12. The article of footwear of claim 11, wherein the guide surface extends continuously across each of the longitudinal member, the medial transverse member, and the lateral transverse member, and wherein the guide surface is contoured in cross section to retain the flexible strand against the guide surface.

13. The article of footwear of claim 1, wherein the groove of the ground engaging surface receives the strand guide.

14. The article of footwear of claim 1, wherein the tensioning system includes a first flexible strand and a second flexible strand, the first flexible strand coupled to the upper member at a first location, the second flexible strand coupled to the upper

20

member at a second location, the first location and the second location being spaced apart along a longitudinal axis of the article of footwear.

15. The article of footwear of claim 1, wherein the upper includes a forefoot region and a heel region, wherein the fitting system also includes a heel strap that is supported by the heel region, and wherein the heel strap is configured to move relative to the sole structure as a result of sliding of the second section across the guide surface.

16. The article of footwear of claim 1, wherein the first section of the flexible strand is attached to the upper at an attachment location, the flexible strand configured to move along a longitudinal axis of the flexible strand relative to the attachment location and remain attached to the upper member at the attachment location.

17. The article of footwear of claim 1, wherein the flexible strand also has an intermediate section that is coupled to the upper member at a first location and that is coupled to the strand guide at a second location, wherein the intermediate section has a section height measured between the first location and the second location, and wherein the section height changes as a result of flexure of the strand guide.

18. The article of footwear of claim 1, wherein the tensioning system also includes a heel strand that extends from a heel region of the upper to couple to the upper member, and wherein the heel strand extends from the upper member to the strand guide to couple to the strand guide.

19. An article of footwear having a medial side, a lateral side, and a longitudinal axis comprising:  
an upper that defines a void for receiving a foot;  
a flexible sole structure that is coupled to the upper and includes a ground-engaging surface, and  
a fitting system that includes:

an upper member that is supported by the upper,  
a strand guide that is supported by the sole structure, the strand guide being flexible and configured to flex in concert with the sole structure between a first position and a second position, and  
a tensioning system including at least one flexible strand that is configured to bias the upper member toward the strand guide, the flexible strand having a medial portion, a lateral portion, and a central portion, the medial portion being coupled to the upper member at the medial side, the lateral portion being coupled to the upper member at the lateral side, the central portion extending through the sole structure, received within a groove formed in the ground-engaging surface of the sole structure, and abutting the strand guide, the central portion configured to slide across the strand guide as a result of flexure of the strand guide between the first position and the second position.

20. The article of footwear of claim 19, wherein the upper includes a forefoot region and a heel region, wherein the fitting system also includes a heel strap that is supported by the heel region, wherein the heel strap is coupled to the upper member, and wherein the heel strap is configured to move relative to the sole structure as a result of sliding of the central portion across the strand guide.

21. The article of footwear of claim 19, wherein the at least one flexible strand includes a first flexible strand and a second flexible strand, wherein the first flexible strand is coupled to the upper member at a first location of the lateral side, wherein the second flexible strand is coupled to the upper member at a second location of the lateral side, wherein the first location and the second location are spaced from each other along the longitudinal axis, wherein the first flexible strand is coupled to the upper member at a third location of the

## 21

medial side, wherein the second flexible strand is coupled to the upper member at a fourth location of the medial side, wherein the third location and the fourth location are spaced from each other along the longitudinal axis.

22. The article of footwear of claim 19, wherein at least one of the medial portion and the lateral portion of the flexible strand is attached to the upper member at an attachment location, the flexible strand configured to move along a longitudinal axis of the flexible strand relative to the attachment location and remain attached to the upper member at the attachment location.

23. An article of footwear having a longitudinal axis extending between a heel region and a forefoot region of the article of footwear, the article of footwear comprising:

an upper that defines a void for receiving a foot;  
a sole structure that is coupled to the upper and includes a ground-engaging surface; and  
a fitting system that comprises:

an upper member that is supported by the upper,  
a strand guide that is supported by the sole structure, the strand guide being flexible and configured to flex in concert with the sole structure between a first position and a second position, the strand guide including a longitudinal member that extends along the longitudinal axis of the article of footwear, the strand guide also including a transverse member that extends transversely from the longitudinal member, the strand guide also including a guide surface that extends continuously across each of the longitudinal member and the transverse member, and

a tensioning system with at least one flexible strand, the strand including a first section, a second section, a third section, and a fourth section,

wherein the first section, the second section, the third section, and the fourth section are arranged continuously in succession along a longitudinal axis of the strand,

wherein the first section is attached to the heel region, wherein the second section extends through the sole structure along the guide surface of the longitudinal member and is received within a first groove formed

## 22

in the ground-engaging surface of the sole structure, wherein the third section extends transversely from the second section through the sole structure and along the guide surface of the transverse member, and wherein the fourth section extends from the third section and is attached to the upper member.

24. The article of footwear of claim 23, wherein the fourth section is attached to the upper member on a medial side of the article of footwear, and wherein the strand also includes a fifth section attached to the upper member on a lateral side of the article of footwear.

25. The article of footwear of claim 24, wherein at least one of the fourth section and the fifth section includes a vertex that is connected to the upper member.

26. The article of footwear of claim 25, wherein at least one of the fourth section and the fifth section includes a first vertex and a second vertex, each of the first vertex and the second vertex being attached to the upper member, the first vertex and the second vertex being spaced apart from each other along the longitudinal axis.

27. The article of footwear of claim 23, wherein the guide surface is contoured in cross section to retain the strand against the guide surface.

28. The article of footwear of claim 27, wherein the guide surface is U-shaped in cross section.

29. The article of footwear of claim 23, wherein the at least one flexible strand includes a first flexible strand and a second flexible strand, wherein each of the first flexible strand and the second flexible strand includes a respective one of the first section, the second section, the third section, and the fourth section.

30. The article of footwear of claim 23, wherein the fourth section is attached to the upper member at an attachment location, the flexible strand configured to move along a longitudinal axis of the flexible strand relative to the attachment location and remain attached to the upper member at the attachment location.

31. The article of footwear of claim 23, wherein the third section is received within a second groove formed in the ground-engaging surface of the sole structure.

\* \* \* \* \*