



US009186066B2

(12) **United States Patent**
Tearney et al.

(10) **Patent No.:** **US 9,186,066 B2**
(45) **Date of Patent:** **Nov. 17, 2015**

(54) **APPARATUS FOR APPLYING A PLURALITY OF ELECTRO-MAGNETIC RADIATIONS TO A SAMPLE**

(75) Inventors: **Guillermo J. Tearney**, Cambridge, MA (US); **Milen Shishkov**, Watertown, MA (US); **Brett Eugene Bouma**, Quincy, MA (US); **Benjamin J. Vakoc**, Cambridge, MA (US)

(73) Assignee: **The General Hospital Corporation**, Boston, MA (US)

(*) Notice: Subject to any disclaimer, the term of this patent is extended or adjusted under 35 U.S.C. 154(b) by 1638 days.

(21) Appl. No.: **11/670,027**

(22) Filed: **Feb. 1, 2007**

(65) **Prior Publication Data**

US 2007/0179487 A1 Aug. 2, 2007

Related U.S. Application Data

(60) Provisional application No. 60/764,622, filed on Feb. 1, 2006, provisional application No. 60/810,868, filed on Jun. 1, 2006.

(51) **Int. Cl.**
A61B 18/18 (2006.01)
A61B 5/00 (2006.01)
(Continued)

(52) **U.S. Cl.**
CPC **A61B 5/0084** (2013.01); **A61B 5/0066** (2013.01); **A61B 5/6852** (2013.01);
(Continued)

(58) **Field of Classification Search**
CPC A61B 5/0084; A61B 18/22; A61B 18/24; A61B 2017/00057; A61B 2018/2211; G02B 6/2938
USPC 602/2-19; 606/2-19, 108; 600/478
See application file for complete search history.

(56) **References Cited**

U.S. PATENT DOCUMENTS
2,339,754 A 1/1944 Brace
3,090,753 A 5/1963 Matuszak et al.

(Continued)

FOREIGN PATENT DOCUMENTS

CN 1550203 12/2004
DE 4105221 9/1991

(Continued)

OTHER PUBLICATIONS

G. Tearney, M. Brezinski, J. Fujimoto, N. Weissman, S. Boppart, B. Bouma, and J. Southern, "Scanning single-mode fiber optic catheter endoscope for optical coherence tomography," Opt. Lett. 21, 543-545 (1996).*

(Continued)

Primary Examiner — William Thomson

Assistant Examiner — Nathan J Jenness

(74) *Attorney, Agent, or Firm* — Andrews Kurth LLP

(57) **ABSTRACT**

An apparatus for applying a plurality of electro-magnetic radiations to a sample is provided. In one exemplary embodiment, the apparatus can include an arrangement which has a specific portion with a plurality of channels. One of channels can facilitate a first radiation of the radiations to be forwarded to the sample that is within an anatomical structure, and another one of the channels can facilitate a second radiation of the radiations to be forwarded to the sample. The first radiation may have a first wavelength band, and the second radiation may have a second wavelength band. The first wavelength band may be substantially different from the second wavelength band. According to another exemplary embodiment, the first radiation can be adapted to be delivered to a first area of the sample, and the second radiation may be capable of being delivered to a second area of the sample. The first area may be substantially enclosed by the second area. According to yet another exemplary embodiment of the present invention, each of the channels can facilitate at least one particular radiation of the radiations to be forwarded to the sample that is within an anatomical structure of the sample, the radiations being delivered to different areas of the sample. Centers of every one of the areas may be provided substantially along a line.

12 Claims, 18 Drawing Sheets

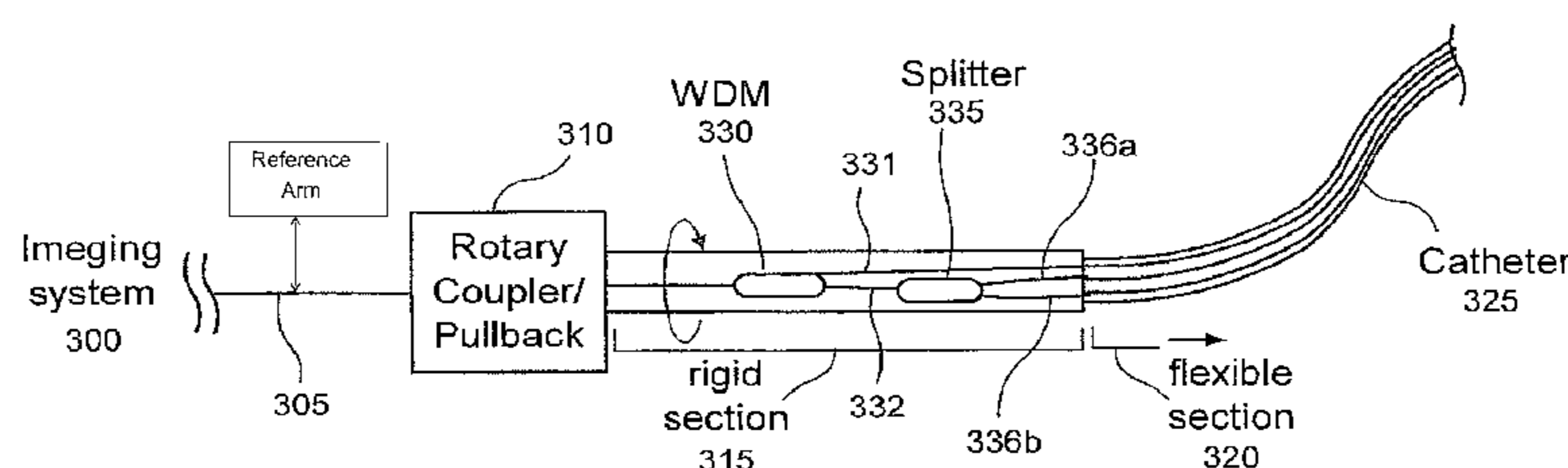

(51)	Int. Cl.		5,212,667 A	5/1993	Tomlinson et al.
	<i>A61B 18/24</i>	(2006.01)	5,214,538 A	5/1993	Lobb
	<i>A61B 17/00</i>	(2006.01)	5,217,456 A	6/1993	Narciso, Jr.
	<i>A61B 17/22</i>	(2006.01)	5,228,001 A	7/1993	Birge et al.
	<i>A61B 18/20</i>	(2006.01)	5,241,364 A	8/1993	Kimura et al.
	<i>A61B 19/00</i>	(2006.01)	5,248,876 A	9/1993	Kerstens et al.
			5,250,186 A	10/1993	Dollinger et al.
			5,251,009 A	10/1993	Bruno
(52)	U.S. Cl.		5,262,644 A	11/1993	Maguire
	CPC	<i>A61B 18/24</i> (2013.01); <i>A61B 2017/00057</i>	5,275,594 A	1/1994	Baker
		(2013.01); <i>A61B 2017/22051</i> (2013.01); <i>A61B</i>	5,281,811 A	1/1994	Lewis
		<i>2018/207</i> (2013.01); <i>A61B 2019/5206</i>	5,283,795 A	2/1994	Fink
		(2013.01); <i>A61B 2019/5217</i> (2013.01)	5,291,885 A	3/1994	Taniji et al.
			5,293,872 A	3/1994	Alfano et al.
			5,293,873 A	3/1994	Fang
			5,302,025 A	4/1994	Kleinerman
(56)	References Cited		5,304,173 A	4/1994	Kittrell et al.
	U.S. PATENT DOCUMENTS		5,304,810 A	4/1994	Amos
			5,305,759 A	4/1994	Kaneko et al.
			5,317,389 A	5/1994	Hochberg et al.
	3,601,480 A	8/1971 Randall	5,318,024 A	6/1994	Kittrell et al.
	3,856,000 A	12/1974 Chikama	5,321,501 A	6/1994	Swanson et al.
	3,872,407 A	3/1975 Hughes	5,333,144 A	7/1994	Liedenbaum et al.
	3,941,121 A	3/1976 Olinger	5,348,003 A	9/1994	Caro
	3,973,219 A	8/1976 Tang et al.	5,353,790 A	10/1994	Jacques et al.
	3,983,507 A	9/1976 Tang et al.	5,383,467 A	1/1995	Auer et al.
	4,030,827 A	6/1977 Delhaye et al.	5,394,235 A	2/1995	Takeuchi et al.
	4,030,831 A	6/1977 Gowrinathan	5,400,771 A	3/1995	Pirak et al.
	4,140,364 A	2/1979 Yamashita et al.	5,404,415 A	4/1995	Mori et al.
	4,141,362 A	2/1979 Wurster	5,411,016 A	5/1995	Kume et al.
	4,224,929 A	9/1980 Furihata	5,414,509 A	5/1995	Veligdan
	4,295,738 A	10/1981 Meltz et al.	5,419,323 A	5/1995	Kittrell et al.
	4,300,816 A	11/1981 Snitzer et al.	5,424,827 A	6/1995	Horwitz et al.
	4,303,300 A	12/1981 Pressiat et al.	5,439,000 A	8/1995	Gunderson et al.
	4,428,643 A	1/1984 Kay	5,441,053 A	8/1995	Lodder et al.
	4,479,499 A	10/1984 Alfano et al.	5,450,203 A	9/1995	Penkethman
	4,533,247 A	8/1985 Epworth	5,454,807 A	10/1995	Lennox et al.
	4,585,349 A	4/1986 Gross et al.	5,459,325 A	10/1995	Hueton et al.
	4,601,036 A	7/1986 Faxvog et al.	5,459,570 A	10/1995	Swanson et al.
	4,607,622 A	8/1986 Fritch et al.	5,465,147 A	11/1995	Swanson
	4,631,498 A	12/1986 Cutler	5,479,928 A	1/1996	Cathignol et al.
	4,639,999 A	2/1987 Daniele	5,486,701 A	1/1996	Norton et al.
	4,650,327 A	3/1987 Ogi	5,491,524 A	2/1996	Hellmuth et al.
	4,682,594 A *	7/1987 Mok 606/7	5,491,552 A	2/1996	Kittrell
	4,734,578 A	3/1988 Horikawa	5,496,305 A *	3/1996	Kittrell et al. 606/15
	4,744,656 A	5/1988 Moran et al.	5,522,004 A	5/1996	Djupsjobacka et al.
	4,751,706 A	6/1988 Rohde et al.	5,526,338 A	6/1996	Hasman et al.
	4,763,977 A	8/1988 Kawasaki et al.	5,555,087 A	9/1996	Miyagawa et al.
	4,770,492 A	9/1988 Levin et al.	5,562,100 A	10/1996	Kittrell et al.
	4,827,907 A	5/1989 Tashiro et al.	5,565,983 A	10/1996	Barnard et al.
	4,834,111 A	5/1989 Khanna et al.	5,565,986 A	10/1996	Knuttel
	4,868,834 A	9/1989 Fox et al.	5,566,267 A	10/1996	Neuberger
	4,890,901 A	1/1990 Cross, Jr.	5,583,342 A	12/1996	Ichie
	4,892,406 A	1/1990 Waters	5,590,660 A	1/1997	MacAulay et al.
	4,905,169 A	2/1990 Buican et al.	5,600,486 A	2/1997	Gal et al.
	4,909,631 A	3/1990 Tan et al.	5,601,087 A	2/1997	Gunderson et al.
	4,925,302 A	5/1990 Cutler	5,621,830 A	4/1997	Lucey et al.
	4,928,005 A	5/1990 Lefèvre et al.	5,623,336 A	4/1997	Raab et al.
	4,940,328 A	7/1990 Hartman	5,628,313 A	5/1997	Webster, Jr.
	4,965,441 A	10/1990 Picard	5,635,830 A	6/1997	Itoh
	4,965,599 A	10/1990 Roddy et al.	5,649,924 A	7/1997	Everett et al.
	4,966,589 A	10/1990 Kaufman	5,697,373 A	12/1997	Richards-Kortum et al.
	4,984,888 A	1/1991 Tobias et al.	5,698,397 A	12/1997	Zarling et al.
	4,993,834 A	2/1991 Carlhoff et al.	5,701,155 A	12/1997	Wood et al.
	4,998,972 A	3/1991 Chin et al.	5,710,630 A	1/1998	Essenpreis et al.
	5,039,193 A	8/1991 Snow et al.	5,716,324 A	2/1998	Toida
	5,040,889 A	8/1991 Keane	5,719,399 A	2/1998	Alfano et al.
	5,045,936 A	9/1991 Lobb et al.	5,730,731 A	3/1998	Mollenauer et al.
	5,046,501 A	9/1991 Crilly	5,735,276 A	4/1998	Lemelson
	5,065,331 A	11/1991 Vachon et al.	5,740,808 A	4/1998	Panescu et al.
	5,085,496 A	2/1992 Yoshida et al.	5,748,318 A	5/1998	Maris et al.
	5,120,953 A	6/1992 Harris	5,748,598 A	5/1998	Swanson et al.
	5,121,983 A	6/1992 Lee	5,752,518 A	5/1998	McGee et al.
	5,127,730 A	7/1992 Brelje et al.	5,776,174 A *	7/1998	Van Tassel 607/89
	5,170,450 A *	12/1992 Dahlgren 385/43	5,784,352 A	7/1998	Swanson et al.
	5,177,488 A	1/1993 Wang et al.	5,785,651 A	7/1998	Kuhn et al.
	5,197,470 A	3/1993 Helfer et al.	5,795,295 A	8/1998	Hellmuth et al.
	5,202,745 A	4/1993 Sorin et al.	5,800,350 A *	9/1998	Coppleson et al. 600/372
	5,202,931 A	4/1993 Bacus et al.	5,801,826 A	9/1998	Williams
	5,208,651 A	5/1993 Buican			

(56)

References Cited

U.S. PATENT DOCUMENTS

5,801,831 A	9/1998	Sargoytchev et al.	6,161,031 A	12/2000	Hochman et al.
5,803,082 A	9/1998	Stapleton et al.	6,166,373 A	12/2000	Mao
5,807,261 A	9/1998	Benaron et al.	6,174,291 B1	1/2001	McMahon et al.
5,810,719 A	9/1998	Toida	6,175,669 B1	1/2001	Colston et al.
5,817,144 A	10/1998	Gregory et al.	6,185,271 B1	2/2001	Kinsinger
5,829,439 A	11/1998	Yokosawa et al.	6,191,862 B1	2/2001	Swanson et al.
5,836,877 A	11/1998	Zavislan et al.	6,193,676 B1	2/2001	Winston et al.
5,840,023 A	11/1998	Oraevsky et al.	6,198,956 B1	3/2001	Dunne
5,840,031 A	11/1998	Crowley	6,201,989 B1	3/2001	Whitehead et al.
5,840,075 A	11/1998	Mueller et al.	6,208,415 B1	3/2001	De Boer et al.
5,842,995 A	12/1998	Mahadevan-Jansen et al.	6,208,887 B1	3/2001	Clarke
5,843,000 A	12/1998	Nishioka et al.	6,245,026 B1	6/2001	Campbell et al.
5,843,052 A	12/1998	Benja-Athon	6,249,349 B1	6/2001	Lauer
5,847,827 A	12/1998	Fercher	6,249,381 B1	6/2001	Suganuma
5,862,273 A	1/1999	Pelletier	6,249,630 B1	6/2001	Stock et al.
5,865,754 A	2/1999	Sevick-Muraca et al.	6,263,234 B1	7/2001	Engelhardt et al.
5,867,268 A	2/1999	Gelikonov et al.	6,264,610 B1	7/2001	Zhu
5,871,449 A	2/1999	Brown	6,272,268 B1	8/2001	Miller et al.
5,872,879 A	2/1999	Hamm	6,272,376 B1	8/2001	Marcu et al.
5,877,856 A	3/1999	Fercher	6,274,871 B1	8/2001	Dukor et al.
5,887,009 A	3/1999	Mandella et al.	6,282,011 B1	8/2001	Tearney et al.
5,892,583 A	4/1999	Li	6,297,018 B1	10/2001	French et al.
5,910,839 A	6/1999	Erskine et al.	6,301,048 B1	10/2001	Cao et al.
5,912,764 A	6/1999	Togino	6,308,092 B1	10/2001	Hoyns
5,920,373 A	7/1999	Bille	6,324,419 B1	11/2001	Guzelsu et al.
5,920,390 A	7/1999	Farahi et al.	6,341,036 B1	1/2002	Tearney et al.
5,921,926 A	7/1999	Rolland et al.	6,353,693 B1	3/2002	Kano et al.
5,926,592 A	7/1999	Harris et al.	6,359,692 B1	3/2002	Groot
5,949,929 A	9/1999	Hamm	6,374,128 B1	4/2002	Toida et al.
5,951,482 A	9/1999	Winston et al.	6,377,349 B1	4/2002	Fercher
5,955,737 A	9/1999	Hallidy et al.	6,384,915 B1	5/2002	Everett et al.
5,956,355 A	9/1999	Swanson et al.	6,393,312 B1	5/2002	Hoyns
5,968,064 A	10/1999	Selmon et al.	6,394,964 B1	5/2002	Sievert, Jr. et al.
5,975,697 A	11/1999	Podoleanu et al.	6,396,941 B1	5/2002	Bacus et al.
5,975,699 A	11/1999	Hellmuth et al.	6,421,164 B2	7/2002	Tearney et al.
5,983,125 A	11/1999	Alfano et al.	6,437,867 B2	8/2002	Zeylikovich et al.
5,987,346 A	11/1999	Benaron et al.	6,441,892 B2	8/2002	Xiao et al.
5,991,697 A	11/1999	Nelson et al.	6,441,959 B1	8/2002	Yang et al.
5,994,690 A	11/1999	Kulkarni et al.	6,445,485 B1	9/2002	Friego et al.
5,995,223 A	11/1999	Power	6,445,939 B1	9/2002	Swanson et al.
6,002,480 A	12/1999	Izatt et al.	6,445,944 B1	9/2002	Ostrovsky
6,004,314 A	12/1999	Wei et al.	6,459,487 B1	10/2002	Chen et al.
6,006,128 A	12/1999	Izatt et al.	6,463,313 B1	10/2002	Winston et al.
6,007,996 A	12/1999	McNamara et al.	6,469,846 B2	10/2002	Ebizuka et al.
6,010,449 A	1/2000	Selmon et al.	6,475,159 B1	11/2002	Casscells et al.
6,011,885 A *	1/2000	Dempewolf et al. 385/34	6,475,210 B1	11/2002	Phelps et al.
6,013,072 A *	1/2000	Winston et al. 606/15	6,477,403 B1	11/2002	Eguchi et al.
6,014,214 A	1/2000	Li	6,485,413 B1	11/2002	Boppart et al.
6,016,197 A	1/2000	Krivoshlykov	6,485,482 B1	11/2002	Belef
6,020,963 A	2/2000	Dimarzio et al.	6,501,551 B1 *	12/2002	Tearney et al. 356/477
6,025,956 A	2/2000	Nagano et al.	6,501,878 B2	12/2002	Hughes et al.
6,033,721 A	3/2000	Nassuphis	6,516,014 B1	2/2003	Sellin et al.
6,037,579 A	3/2000	Chan et al.	6,517,532 B1	2/2003	Altshuler et al.
6,044,288 A	3/2000	Wake et al.	6,538,817 B1	3/2003	Farmer et al.
6,045,511 A	4/2000	Ott et al.	6,540,391 B2	4/2003	Lanzetta et al.
6,048,742 A	4/2000	Weyburne et al.	6,549,801 B1	4/2003	Chen et al.
6,052,186 A	4/2000	Tsai	6,552,796 B2	4/2003	Magnin et al.
6,053,613 A	4/2000	Wei et al.	6,556,305 B1	4/2003	Aziz et al.
6,063,093 A *	5/2000	Winston et al. 606/108	6,556,853 B1	4/2003	Cabib et al.
6,069,698 A	5/2000	Ozawa et al.	6,558,324 B1	5/2003	Von Behren et al.
6,078,047 A	6/2000	Mittleman et al.	6,560,259 B1	5/2003	Hwang et al.
6,091,496 A	7/2000	Hill	6,564,087 B1	5/2003	Pitris et al.
6,091,984 A	7/2000	Perelman et al.	6,564,089 B2	5/2003	Izatt et al.
6,094,274 A	7/2000	Yokoi	6,567,585 B2	5/2003	Harris
6,107,048 A	8/2000	Goldenring et al.	6,593,101 B2	7/2003	Richards-Kortum et al.
6,111,645 A	8/2000	Tearney et al.	6,611,833 B1	8/2003	Johnson et al.
6,117,128 A	9/2000	Gregory	6,615,071 B1	9/2003	Casscells, III et al.
6,120,516 A	9/2000	Selmon et al.	6,622,732 B2	9/2003	Constantz
6,134,003 A	10/2000	Tearney et al.	6,654,127 B2	11/2003	Everett et al.
6,134,010 A	10/2000	Zavislan	6,657,730 B2	12/2003	Pfau et al.
6,134,033 A	10/2000	Bergano et al.	6,658,278 B2	12/2003	Gruhl
6,141,577 A	10/2000	Rolland et al.	6,680,780 B1	1/2004	Fee
6,151,522 A	11/2000	Alfano et al.	6,685,885 B2	2/2004	Nolte et al.
6,159,445 A	12/2000	Klaveness et al.	6,687,007 B1	2/2004	Meigs
6,160,826 A	12/2000	Swanson et al.	6,687,010 B1	2/2004	Horii et al.
			6,687,036 B2	2/2004	Riza
			6,692,430 B2	2/2004	Adler
			6,701,181 B2	3/2004	Tang et al.
			6,721,094 B1	4/2004	Sinclair et al.

(56)

References Cited

U.S. PATENT DOCUMENTS

6,725,073 B1	4/2004	Motamedi et al.	8,315,282 B2	11/2012	Huber et al.
6,738,144 B1	5/2004	Dogariu et al.	2001/0020126 A1	9/2001	Swanson et al.
6,741,355 B2	5/2004	Drabarek	2001/0036002 A1	11/2001	Tearney et al.
6,741,884 B1	5/2004	Freeman et al.	2001/0047137 A1	11/2001	Moreno et al.
6,749,623 B1 *	6/2004	Hsi et al. 607/88	2001/0055462 A1	12/2001	Seibel
6,757,467 B1	6/2004	Rogers	2002/0016533 A1	2/2002	Marchitto et al.
6,790,175 B1	9/2004	Furusawa et al.	2002/0024015 A1	2/2002	Hoffmann et al.
6,806,963 B1	10/2004	Wälti et al.	2002/0026127 A1 *	2/2002	Balbierz et al. 600/567
6,816,743 B2	11/2004	Moreno et al.	2002/0037252 A1	3/2002	Toida et al.
6,831,781 B2	12/2004	Tearney et al.	2002/0048025 A1	4/2002	Takaoka
6,839,496 B1	1/2005	Mills et al.	2002/0048026 A1	4/2002	Isshiki et al.
6,847,454 B2 *	1/2005	Crowley et al. 356/479	2002/0052547 A1	5/2002	Toida
6,869,430 B2 *	3/2005	Balbierz et al. 606/41	2002/0057431 A1	5/2002	Fateley et al.
6,870,620 B2 *	3/2005	Faupel et al. 356/337	2002/0064341 A1	5/2002	Fauver et al.
6,882,432 B2	4/2005	Deck	2002/0076152 A1	6/2002	Hughes et al.
6,895,137 B2 *	5/2005	Zuluaga et al. 385/15	2002/0085209 A1	7/2002	Mittleman et al.
6,900,899 B2	5/2005	Nevis	2002/0086347 A1	7/2002	Johnson et al.
6,903,820 B2	6/2005	Wang	2002/0091322 A1	7/2002	Chaiken et al.
6,904,199 B2 *	6/2005	Zuluaga 385/33	2002/0093662 A1	7/2002	Chen et al.
6,909,105 B1	6/2005	Heintzmann et al.	2002/0109851 A1	8/2002	Deck
6,949,072 B2	9/2005	Furnish et al.	2002/0113965 A1	8/2002	Roche et al.
6,961,123 B1	11/2005	Wang et al.	2002/0122182 A1	9/2002	Everett et al.
6,980,299 B1	12/2005	de Boer	2002/0122246 A1	9/2002	Tearney et al.
6,996,549 B2	2/2006	Zhang et al.	2002/0140942 A1	10/2002	Fee et al.
7,006,231 B2	2/2006	Ostrovsky et al.	2002/0158211 A1	10/2002	Gillispie
7,006,232 B2	2/2006	Rollins et al.	2002/0161357 A1	10/2002	Anderson et al.
7,019,838 B2	3/2006	Izatt et al.	2002/0163622 A1	11/2002	Magnin et al.
7,027,633 B2	4/2006	Foran et al.	2002/0166946 A1	11/2002	Iizuka et al.
7,061,622 B2	6/2006	Rollins et al.	2002/0168158 A1	11/2002	Furusawa et al.
7,072,047 B2	7/2006	Westphal et al.	2002/0172485 A1	11/2002	Keaton et al.
7,075,658 B2	7/2006	Izatt et al.	2002/0183623 A1	12/2002	Tang et al.
7,099,358 B1	8/2006	Chong	2002/0188204 A1	12/2002	McNamara et al.
7,113,288 B2	9/2006	Fercher	2002/0196446 A1	12/2002	Roth et al.
7,113,625 B2	9/2006	Watson et al.	2002/0198457 A1	12/2002	Tearney et al.
7,130,320 B2	10/2006	Tobiason et al.	2003/0001071 A1	1/2003	Mandella et al.
7,139,598 B2	11/2006	Hull et al.	2003/0013973 A1	1/2003	Georgakoudi et al.
7,142,835 B2	11/2006	Paulus	2003/0023153 A1	1/2003	Izatt et al.
7,148,970 B2	12/2006	De Boer	2003/0025917 A1	2/2003	Suhami
7,177,027 B2	2/2007	Hirasawa et al.	2003/0026735 A1	2/2003	Nolte et al.
7,190,464 B2	3/2007	Alphonse	2003/0028114 A1	2/2003	Casscells, III et al.
7,230,708 B2	6/2007	Lapotko et al.	2003/0030816 A1	2/2003	Eom et al.
7,231,243 B2	6/2007	Tearney et al.	2003/0043381 A1	3/2003	Fercher
7,236,637 B2	6/2007	Sirohey et al.	2003/0053673 A1	3/2003	Dewaele et al.
7,242,480 B2	7/2007	Alphonse	2003/0067607 A1	4/2003	Wolleschensky et al.
7,267,494 B2	9/2007	Deng et al.	2003/0082105 A1	5/2003	Fischman et al.
7,272,252 B2	9/2007	De La Torre-Bueno et al.	2003/0097048 A1	5/2003	Ryan et al.
7,304,798 B2	12/2007	Izumi et al.	2003/0103212 A1	6/2003	Westphal et al.
7,310,150 B2	12/2007	Guillermo et al.	2003/0108911 A1	6/2003	Klimant et al.
7,330,270 B2	2/2008	O'Hara et al.	2003/0120137 A1	6/2003	Pawluczyk et al.
7,336,366 B2	2/2008	Choma et al.	2003/0135101 A1	7/2003	Webler
7,342,659 B2	3/2008	Horn et al.	2003/0137669 A1	7/2003	Rollins et al.
7,355,716 B2	4/2008	De Boer et al.	2003/0164952 A1	9/2003	Deichmann et al.
7,355,721 B2	4/2008	Quadling et al.	2003/0165263 A1	9/2003	Hamer et al.
7,359,062 B2	4/2008	Chen et al.	2003/0171691 A1	9/2003	Casscells, III et al.
7,365,858 B2	4/2008	Fang-Yen et al.	2003/0174339 A1	9/2003	Feldchtein et al.
7,366,376 B2	4/2008	Shishkov et al.	2003/0191392 A1	10/2003	Haldeman
7,382,809 B2	6/2008	Chong et al.	2003/0199769 A1	10/2003	Podoleanu et al.
7,391,520 B2	6/2008	Zhou et al.	2003/0216719 A1	11/2003	Debenedictis et al.
7,458,683 B2	12/2008	Chernyak et al.	2003/0218756 A1	11/2003	Chen et al.
7,530,948 B2	5/2009	Seibel et al.	2003/0220749 A1	11/2003	Chen et al.
7,539,530 B2	5/2009	Caplan et al.	2003/0236443 A1	12/2003	Cespedes et al.
7,609,391 B2	10/2009	Betzig	2004/0002650 A1	1/2004	Mandrusov et al.
7,630,083 B2	12/2009	de Boer et al.	2004/0021848 A1 *	2/2004	Bambot et al. 356/39
7,643,152 B2	1/2010	de Boer et al.	2004/0039252 A1	2/2004	Koch
7,643,153 B2	1/2010	de Boer et al.	2004/0039298 A1	2/2004	Abreu
7,646,905 B2	1/2010	Guittet et al.	2004/0054268 A1	3/2004	Esenaliev et al.
7,649,160 B2	1/2010	Colomb et al.	2004/0072200 A1	4/2004	Rigler et al.
7,664,300 B2	2/2010	Lange et al.	2004/0075841 A1	4/2004	Van Neste et al.
7,733,497 B2	6/2010	Yun et al.	2004/0076940 A1	4/2004	Alexander et al.
7,782,464 B2	8/2010	Mujat et al.	2004/0077949 A1	4/2004	Blofgett et al.
7,799,558 B1	9/2010	Dultz	2004/0085540 A1	5/2004	Lapotko et al.
7,805,034 B2	9/2010	Kato et al.	2004/0086245 A1	5/2004	Farroni et al.
7,911,621 B2	3/2011	Motaghianezam et al.	2004/0095464 A1	5/2004	Miyagi et al.
7,969,578 B2	6/2011	Yun et al.	2004/0100631 A1	5/2004	Bashkansky et al.
7,973,936 B2	7/2011	Dantus	2004/0100681 A1	5/2004	Bjarklev et al.
			2004/0110206 A1	6/2004	Wong et al.
			2004/0111032 A1 *	6/2004	Korn 600/478
			2004/0126048 A1	7/2004	Dave et al.
			2004/0126120 A1	7/2004	Cohen et al.

(56)

References Cited

U.S. PATENT DOCUMENTS

2004/0133191 A1 7/2004 Momiuchi et al.
 2004/0150829 A1 8/2004 Koch et al.
 2004/0150830 A1 8/2004 Chan
 2004/0152989 A1 8/2004 Puttappa et al.
 2004/0165184 A1 8/2004 Mizuno
 2004/0166593 A1 8/2004 Nolte et al.
 2004/0189999 A1 9/2004 De Groot et al.
 2004/0204651 A1 10/2004 Freeman et al.
 2004/0212808 A1 10/2004 Okawa et al.
 2004/0239938 A1 12/2004 Izatt et al.
 2004/0246490 A1 12/2004 Wang
 2004/0246583 A1 12/2004 Mueller et al.
 2004/0247268 A1 12/2004 Ishihara et al.
 2004/0254474 A1 12/2004 Seibel et al.
 2004/0258106 A1 12/2004 Araujo et al.
 2004/0263843 A1 12/2004 Knopp et al.
 2005/0004453 A1 1/2005 Tearney et al.
 2005/0018133 A1 1/2005 Huang et al.
 2005/0018200 A1 1/2005 Guillermo et al.
 2005/0018201 A1 1/2005 De Boer et al.
 2005/0035295 A1 2/2005 Bouma et al.
 2005/0036150 A1 2/2005 Izatt et al.
 2005/0046837 A1 3/2005 Izumi et al.
 2005/0049488 A1 3/2005 Homan
 2005/0057680 A1 3/2005 Agan
 2005/0057756 A1 3/2005 Fang-Yen et al.
 2005/0059894 A1 3/2005 Zeng et al.
 2005/0065421 A1 3/2005 Burckhardt et al.
 2005/0075547 A1 4/2005 Wang
 2005/0075704 A1* 4/2005 Tu et al. 607/88
 2005/0083534 A1 4/2005 Riza et al.
 2005/0119567 A1 6/2005 Choi et al.
 2005/0128488 A1 6/2005 Yelin et al.
 2005/0159731 A1* 7/2005 Lee 606/1
 2005/0165303 A1 7/2005 Kleen et al.
 2005/0171437 A1* 8/2005 Carberry 600/476
 2005/0171438 A1 8/2005 Chen et al.
 2005/0190372 A1 9/2005 Dogariu et al.
 2005/0197530 A1 9/2005 Wallace et al.
 2005/0221270 A1 10/2005 Connelly et al.
 2005/0254059 A1 11/2005 Alphonse
 2005/0254061 A1 11/2005 Alphonse et al.
 2006/0020172 A1 1/2006 Luerssen et al.
 2006/0033923 A1 2/2006 Hirasawa et al.
 2006/0039004 A1 2/2006 De Boer et al.
 2006/0093276 A1 5/2006 Bouma et al.
 2006/0103850 A1 5/2006 Alphonse et al.
 2006/0106375 A1 5/2006 Werneth et al.
 2006/0146339 A1 7/2006 Fujita et al.
 2006/0155193 A1 7/2006 Leonardi et al.
 2006/0164639 A1 7/2006 Horn et al.
 2006/0167363 A1 7/2006 Osypka et al.
 2006/0171503 A1 8/2006 O'Hara et al.
 2006/0184048 A1 8/2006 Saadat et al.
 2006/0189928 A1 8/2006 Camus et al.
 2006/0193352 A1 8/2006 Chong et al.
 2006/0224053 A1 10/2006 Black et al.
 2006/0241572 A1* 10/2006 Zhou 606/7
 2006/0244973 A1 11/2006 Yun et al.
 2006/0279742 A1 12/2006 Tearney
 2007/0002435 A1 1/2007 Ye et al.
 2007/0019208 A1 1/2007 Toida et al.
 2007/0024860 A1 2/2007 Tobiason et al.
 2007/0035743 A1 2/2007 Vakoc et al.
 2007/0038040 A1 2/2007 Cense et al.
 2007/0048818 A1 3/2007 Rosen et al.
 2007/0070496 A1 3/2007 Gweon et al.
 2007/0076212 A1* 4/2007 Zuluaga 356/477
 2007/0076217 A1 4/2007 Baker et al.
 2007/0086013 A1 4/2007 De Lega et al.
 2007/0086017 A1 4/2007 Buckland et al.
 2007/0091317 A1 4/2007 Freischlad et al.
 2007/0133002 A1 6/2007 Wax et al.
 2007/0188855 A1 8/2007 Shishkov et al.
 2007/0203404 A1 8/2007 Zysk et al.

2007/0208225 A1 9/2007 Czaniera et al.
 2007/0223006 A1 9/2007 Tearney et al.
 2007/0233056 A1 10/2007 Yun
 2007/0233396 A1 10/2007 Tearney et al.
 2007/0236700 A1 10/2007 Yun et al.
 2007/0253901 A1 11/2007 Deng et al.
 2007/0258094 A1 11/2007 Izatt et al.
 2007/0263226 A1 11/2007 Kurtz et al.
 2007/0291277 A1 12/2007 Everett et al.
 2008/0002197 A1 1/2008 Sun et al.
 2008/0007734 A1 1/2008 Park et al.
 2008/0013960 A1 1/2008 Tearney et al.
 2008/0021275 A1 1/2008 Tearney et al.
 2008/0049220 A1 2/2008 Izzia et al.
 2008/0070323 A1 3/2008 Hess et al.
 2008/0094613 A1 4/2008 de Boer et al.
 2008/0094637 A1 4/2008 de Boer et al.
 2008/0097225 A1 4/2008 Tearney et al.
 2008/0097709 A1 4/2008 de Boer et al.
 2008/0100837 A1 5/2008 de Boer et al.
 2008/0139906 A1 6/2008 Bussek et al.
 2008/0152353 A1 6/2008 de Boer et al.
 2008/0154090 A1 6/2008 Hashimshony
 2008/0192236 A1 8/2008 Smith et al.
 2008/0201081 A1 8/2008 Reid
 2008/0204762 A1 8/2008 Izatt et al.
 2008/0218696 A1 9/2008 Mir
 2008/0226029 A1 9/2008 Weir et al.
 2008/0228086 A1 9/2008 Ilegbusi
 2008/0234560 A1 9/2008 Nomoto et al.
 2008/0252901 A1 10/2008 Shimizu
 2008/0265130 A1 10/2008 Colomb et al.
 2008/0297806 A1 12/2008 Motaghianezam
 2008/0308730 A1 12/2008 Vizi et al.
 2009/0004453 A1 1/2009 Murai et al.
 2009/0005691 A1 1/2009 Huang
 2009/0011948 A1 1/2009 Uniu et al.
 2009/0012368 A1 1/2009 Banik et al.
 2009/0044799 A1 2/2009 Qiu
 2009/0051923 A1 2/2009 Zuluaga
 2009/0131801 A1 5/2009 Suter et al.
 2009/0192358 A1 7/2009 Jaffer et al.
 2009/0196477 A1 8/2009 Cense et al.
 2009/0209834 A1 8/2009 Fine
 2009/0273777 A1 11/2009 Yun et al.
 2009/0281390 A1 11/2009 Qiu et al.
 2009/0290156 A1 11/2009 Popescu et al.
 2009/0305309 A1 12/2009 Chien et al.
 2009/0306520 A1 12/2009 Schmitt et al.
 2009/0323056 A1 12/2009 Yun et al.
 2010/0002241 A1 1/2010 Hirose
 2010/0086251 A1 4/2010 Xu et al.
 2010/0094576 A1 4/2010 de Boer et al.
 2010/0145145 A1 6/2010 Shi et al.
 2010/0150467 A1 6/2010 Zhao et al.
 2010/0261995 A1 10/2010 Mckenna et al.
 2011/0028967 A1 2/2011 Rollins et al.
 2011/0160681 A1 6/2011 Dacey, Jr. et al.
 2011/0218403 A1 9/2011 Tearney et al.

FOREIGN PATENT DOCUMENTS

DE 4309056 9/1994
 DE 19542955 5/1997
 DE 10351319 6/2005
 DE 102005034443 2/2007
 EP 0110201 6/1984
 EP 0251062 1/1988
 EP 0617286 2/1994
 EP 0590268 4/1994
 EP 0697611 2/1996
 EP 0728440 8/1996
 EP 0933096 8/1999
 EP 1324051 7/2003
 EP 1426799 6/2004
 EP 2149776 2/2010
 FR 2738343 8/1995
 GB 1257778 12/1971
 GB 2030313 4/1980

(56)

References Cited

FOREIGN PATENT DOCUMENTS					
			RU	2209094	7/2003
			RU	2213421	9/2003
			RU	2242710	12/2004
			RU	2255426	6/2005
			RU	2108122	6/2006
GB	2209221	5/1989	WO	7900841	10/1979
GB	2298054	8/1996	WO	9201966	2/1992
JP	6073405	4/1985	WO	WO 92/03977 A2	3/1992
JP	62-188001	6/1989	WO	9216865	10/1992
JP	04-056907	2/1992	WO	9219930	11/1992
JP	20040056907	2/1992	WO	9303672	3/1993
JP	4135550	5/1992	WO	9216865	10/1993
JP	4135551	5/1992	WO	9533971	12/1995
JP	5509417	11/1993	WO	96-02184	2/1996
JP	H8-136345	5/1996	WO	96-04839	2/1996
JP	H08-160129	6/1996	WO	9628212	9/1996
JP	9-10213	1/1997	WO	9732182	9/1997
JP	9-230248	9/1997	WO	9800057	1/1998
JP	10-213485	8/1998	WO	9801074	1/1998
JP	10-267631	10/1998	WO	9814132	4/1998
JP	10-267830	10/1998	WO	9835203	8/1998
JP	2259617	10/1999	WO	9838907	9/1998
JP	2000-023978	1/2000	WO	9846123	10/1998
JP	2000-046729	2/2000	WO	9848838	11/1998
JP	2000-121961	4/2000	WO	9848846	11/1998
JP	2000-504234	4/2000	WO	9905487	2/1999
JP	2000-126116	5/2000	WO	9944089	2/1999
JP	2000-131222	5/2000	WO	99-28856	6/1999
JP	2001-4447	1/2001	WO	99-45838	9/1999
JP	2001-500026	1/2001	WO	9944089	9/1999
JP	2001-104315	4/2001	WO	99-45338	10/1999
JP	2001-174404	6/2001	WO	9957507	11/1999
JP	2001-174744	6/2001	WO	00-42906	7/2000
JP	2001-507251	6/2001	WO	00-43730	7/2000
JP	2001-508340	6/2001	WO	0058766	10/2000
JP	2007-539336	6/2001	WO	01-04828	1/2001
JP	2001-212086	8/2001	WO	0101111	1/2001
JP	2008-533712	8/2001	WO	0108579	2/2001
JP	2001-264246	9/2001	WO	0127679	4/2001
JP	2001-515382	9/2001	WO	01-33215	5/2001
JP	2001-525580	12/2001	WO	0138820	5/2001
JP	2002-503134	1/2002	WO	01-42735	6/2001
JP	2002-035005	2/2002	WO	0142735	6/2001
JP	2002-205434	2/2002	WO	01-82786	11/2001
JP	2002-095663	4/2002	WO	02-37075	5/2002
JP	2002-113017	4/2002	WO	0236015	5/2002
JP	2002-148185	5/2002	WO	0237075	5/2002
JP	2002-516586	6/2002	WO	0238040	5/2002
JP	2002-214127	7/2002	WO	02-45572	6/2002
JP	2002-214128	7/2002	WO	02-68853	6/2002
JP	2002214127	7/2002	WO	02053050	7/2002
JP	2003-014585	1/2003	WO	02054027	7/2002
JP	2003-504627	2/2003	WO	02-083003	10/2002
JP	20030035659	2/2003	WO	02084263	10/2002
JP	2003-512085	4/2003	WO	03-003903	1/2003
JP	2003-513278	4/2003	WO	03-012405	2/2003
JP	2003-516531	5/2003	WO	03-013624	2/2003
JP	2004-028970	1/2004	WO	03013624	2/2003
JP	2004-037165	2/2004	WO	03020119	3/2003
JP	2004-057652	2/2004	WO	03046495	6/2003
JP	2004-089552	3/2004	WO	03046636	6/2003
JP	2004-113780	4/2004	WO	03052478	6/2003
JP	2004-514920	5/2004	WO	03053226	7/2003
JP	2004-258144	9/2004	WO	03062802	7/2003
JP	2004-317437	11/2004	WO	03-088826	10/2003
JP	2005-062850	3/2005	WO	03105678	12/2003
JP	2005-110208	4/2005	WO	2004034869	4/2004
JP	2005-510323	4/2005	WO	2004-037068	5/2004
JP	2005-156540	6/2005	WO	2004-043251	5/2004
JP	2005-516187	6/2005	WO	2004057266	7/2004
JP	2005-195485	7/2005	WO	2004066824	8/2004
JP	2005-241872	9/2005	WO	2004-073501	9/2004
JP	2006-237359	9/2006	WO	2004088361	10/2004
JP	2007-500059	1/2007	WO	2004-100789	11/2004
JP	2007-075403	3/2007	WO	2004-105598	12/2004
JP	2007-83053	4/2007	WO	2004105598	12/2004
JP	2007-524455	8/2007	WO	2005000115	1/2005
JP	2007271761	10/2007	WO	2005-045362	5/2005
JP	2003-102672	4/2012	WO	2005-047813	5/2005
RU	2149464	5/2000	WO		

(56)

References Cited

FOREIGN PATENT DOCUMENTS

WO	2005047813	5/2005
WO	2005054780	6/2005
WO	2005082225	9/2005
WO	2006004743	1/2006
WO	2006-020605	2/2006
WO	2006014392	2/2006
WO	2006038876	4/2006
WO	2006039091	4/2006
WO	2006-050320	5/2006
WO	2006-058187	6/2006
WO	2006059109	6/2006
WO	2006124860	11/2006
WO	2006-131859	12/2006
WO	2006130797	12/2006
WO	2007-030835	3/2007
WO	2007028531	3/2007
WO	2007038787	4/2007
WO	2007083138	7/2007
WO	2007084995	7/2007
WO	2009-033064	3/2009
WO	2009153929	12/2009
WO	2011-055376	5/2011
WO	2011-080713	7/2011

OTHER PUBLICATIONS

European Official Action dated Dec. 2, 2008 for EP 07718117.0.

Barfuss et al (1989) "Modified Optical Frequency Domain Reflectometry with High spatial Resolution for Components of integrated optic Systems", Journal of Lightwave Technology, IEEE vol. 7., No. 1.

Yun et al., (2004) "Removing the Depth-Degeneracy in Optical Frequency Domain Imaging with Frequency Shifting", Optics Express, vol. 12, No. 20.

International Search Report and Written Opinion dated Jun. 10, 2009 for PCT/US08/075456.

European Search Report issued May 5, 2009 for European Application No. 01991471.2.

Motz, J.T. et al: "Spectral- and Frequency-Encoded Fluorescence Imaging" Optics Letters, OSA, Optical Society of America, Washington, DC, US, vol. 30, No. 20, Oct. 15, 2005, pp. 2760-2762.

Japanese Notice of Reasons for Rejection dated Jul. 14, 2009 for Japanese Patent application No. 2006-503161.

Office Action dated Aug. 18, 2009 for U.S. Appl. No. 12/277,178.

Office Action dated Aug. 13, 2009 for U.S. Appl. No. 10/136,813.

Office Action dated Aug. 6, 2009 for U.S. Appl. No. 11/624,455.

Office Action dated May 15, 2009 for U.S. Appl. No. 11/537,123.

Office Action dated Apr. 17, 2009 for U.S. Appl. No. 11/537,343.

Office Action dated Apr. 15, 2009 for U.S. Appl. No. 12/205,775.

Office Action dated Dec. 9, 2008 for U.S. Appl. No. 09/709,162.

Office Action dated Dec. 23, 2008 for U.S. Appl. No. 11/780,261.

Office Action dated Jan. 9, 2010 for U.S. Appl. No. 11/624,455.

Office Action dated Feb. 18, 2009 for U.S. Appl. No. 11/285,301.

Beddow et al, (May 2002) "Improved Performance Interferometer Designs for Optical Coherence Tomography", IEEE Optical Fiber Sensors Conference, pp. 527-530.

Yaqoob et al., (Jun. 2002) "High-Speed Wavelength-Multiplexed Fiber-Optic Sensors for Biomedicine," Sensors Proceedings of the IEEE, pp. 325-330.

Office Action dated Feb. 18, 2009 for U.S. Appl. No. 11/697,012.

Zhang et al, (Sep. 2004), "Fourier Domain Functional Optical Coherence Tomography", Saratov Fall Meeting 2004, pp. 8-14.

Office Action dated Feb. 23, 2009 for U.S. Appl. No. 11/956,129.

Office Action dated Mar. 16, 2009 for U.S. Appl. No. 11/621,694.

Office Action dated Oct. 1, 2009 for U.S. Appl. No. 11/677,278.

Office Action dated Oct. 6, 2009 for U.S. Appl. No. 12/015,642.

Lin, Stollen et al., (1977) "A CW Tunable Near-infrared (1.085-1.175-um) Raman Oscillator," Optics Letters, vol. 1, 96.

Summons to attend Oral Proceedings dated Oct. 9, 2009 for European patent application No. 06813365.1.

Office Action dated Dec. 15, 2009 for U.S. Appl. No. 11/549,397.

Devesa, Susan S. et al. (1998) "Changing Patterns in the Incidence of Esophageal and Gastric Carcinoma in the United States." *American Cancer Society* vol. 83, No. 10 pp. 2049-2053.

Barr, H et al. (2005) "Endoscopic Therapy for Barrett's Oesophagus" *Gut* vol. 54:875-884.

Johnston, Mark H.(2005) "Technology Insight: Ablative Techniques for Barrett's Esophagus—Current and Emerging Trends" www.Nature.com/clinicalpractice/gasthep.

Falk, Gary W. et al. (1997) "Surveillance of Patients with Barrett's Esophagus for Dysplasia and Cancer with Ballon Cytology" *Gastroenterology* vol. 112, pp. 1787-1797.

Sepchler, Stuart Jon. (1997) "Barrett's Esophagus: Should We Brush off this Balloning Problem?" *Gastroenterology* vol. 112, pp. 2138-2152.

Froehly, J. et al. (2003) "Multiplexed 3D Imaging Using Wavelength Encoded Spectral Interferometry: A Proof of Principle" *Optics Communications* vol. 222, pp. 127-136.

Kubba A.K. et al. (1999) "Role of p53 Assessment in Management of Barrett's Esophagus" *Digestive Disease and Sciences* vol. 44, No. 4. pp. 659-667.

Reid, Brian J. (2001) "p53 and Neoplastic Progression in Barrett's Esophagus" *The American Journal of Gastroenterology* vol. 96, No. 5, pp. 1321-1323.

Sharma, P. et al.(2003) "Magnification Chromoendoscopy for the Detection of Intestinal Metaplasia and Dysplasia in Barrett's Oesophagus" *Gut* vol. 52, pp. 24-27.

Kuipers E.J et al. (2005) "Diagnostic and Therapeutic Endoscopy" *Journal of Surgical Oncology* vol. 92, pp. 203-209.

Georgakoudi, Irene et al. (2001) "Fluorescence, Reflectance, and Light-Scattering Spectroscopy for Evaluating Dysplasia in Patients with Barrett's Esophagus" *Gastroenterology* vol. 120, pp. 1620-1629.

Adrain, Alyn L. et al. (1997) "High-Resolution Endoluminal Sonography is a Sensitive Modality for the Identification of Barrett's Meaplasia" *Gastrointestinal Endoscopy* vol. 46, No. 2, pp. 147-151.

Canto, Marcia Irene et al (1999) "Vital Staining and Barrett's Esophagus" *Gastrointestinal Endoscopy* vol. 49, No. 3, part 2, pp. 12-16.

Evans, John A. et al. (2006) "Optical Coherence Tomography to Identify Intramucosal Carcinoma and High-Grade Dysplasia in Barrett's Esophagus" *Clinical Gastroenterology and Hepatology* vol. 4, pp. 38-3.

Poneros, John M. et al. (2001) "Diagnosis of Specialized Intestinal Metaplasia by Optical Coherence Tomography" *Gastroenterology* vol. 120, pp. 7-12.

Ho, W. Y. et al. (2005) "115 KHz Tuning Repetition Rate Ultrahigh-Speed Wavelength-Swept Semiconductor Laser" *Optics Letters* col. 30, No. 23, pp. 3159-3161.

Brown, Stanley B. et al. (2004) "The Present and Future Role of Photodynamic Therapy in Cancer Treatment" *The Lancet Oncology* vol. 5, pp. 497-508.

Boogert, Jolanda Van Den et al. (1999) "Endoscopic Ablation Therapy for Barrett's Esophagus with High-Grade Dysplasia: A Review" *The American Journal of Gastroenterology* vol. 94, No. 5, pp. 1153-1160.

Sampliner, Richard E. et al. (1996) "Reversal of Barrett's Esophagus with Acid Suppression and Multipolar Electrocoagulation: Preliminary Results" *Gastrointestinal Endoscopy* vol. 44, No. 5, pp. 532-535.

Sampliner, Richard E. (2004) "Endoscopic Ablative Therapy for Barrett's Esophagus: Current Status" *Gastrointestinal Endoscopy* vol. 59, No. 1, pp. 66-69.

Soetikno, Roy M. et al. (2003) "Endoscopic Mucosal resection" *Gastrointestinal Endoscopy* vol. 57, No. 4, pp. 567-579.

Ganz, Robert A. et al. (2004) "Complete Ablation of Esophageal Epithelium with a Balloon-based Bipolar Electrode: A Phased Evaluation in the Porcine and in the Human Esophagus" *Gastrointestinal Endoscopy* vol. 60, No. 6, pp. 1002-1010.

Pfefer, Jorje et al. (2006) "Performance of the Aer-O-Scope, A Pneumatic, Self Propelling, Self Navigating Colonoscope in Animal Experiments" *Gastrointestinal Endoscopy* vol. 63, No. 5, pp. AB223.

(56)

References Cited

OTHER PUBLICATIONS

- Overholt, Bergein F. et al. (1999) "Photodynamic Therapy for Barrett's Esophagus: Follow-Up in 100 Patients" *Gastrointestinal Endoscopy* vol. 49, No. 1, pp. 1-7.
- Vogel, Alfred et al. (2003) "Mechanisms of Pulsed Laser Ablation of Biological Tissues" *American Chemical Society* vol. 103, pp. 577-644.
- McKenzie, A. L. (1990) "Physics of Thermal Processes in Laser-Tissue Interaction" *Phys. Med. Biol* vol. 35, No. 9, pp. 1175-1209.
- Anderson, R. Rox et al. (1983) "Selective Photothermolysis" *Precise Microsurgery by Selective Absorption of Pulsed Radiation Science* vol. 220, No. 4596, pp. 524-527.
- Jacques, Steven L. (1993) "Role of Tissue Optics and Pulse Duration on Tissue Effects During High-Power Laser Irradiation" *Applied Optics* vol. 32, No. 13, pp. 2447-2454.
- Nahen, Kester et al. (1999) "Investigations on Acoustic On-Line Monitoring of IR Laser Ablation of burned Skin" *Lasers in Surgery and Medicine* vol. 25, pp. 69-78.
- Jerath, Maya R. et al. (1993) "Calibrated Real-Time Control of Lesion Size Based on Reflectance Images" *Applied Optics* vol. 32, No. 7, pp. 1200-1209.
- Jerath, Maya R. et al (1992) "Dynamic Optical Property Changes: Implications for Reflectance Feedback Control of Photocoagulation" *Journal of Photochemical, Photobiology. B: Biol* vol. 16, pp. 113-126.
- Deckelbaum, Lawrence I. (1994) "Coronary Laser Angioplasty" *Lasers in Surgery and Medicine* vol. 14, pp. 101-110.
- Kim, B.M. et al. (1998) "Optical Feedback Signal for Ultrashort Laser Pulse Ablation of Tissue" *Applied Surface Science* vol. 127-129, pp. 857-862.
- Brinkman, Ralf et al. (1996) "Analysis of Cavitation Dynamics During Pulsed Laser Tissue Ablation by Optical On-Line Monitoring" *IEEE Journal of Selected Topics in Quantum Electronics* vol. 2, No. 4, pp. 826-835.
- Whelan, W.M. et al. (2005) "A novel Strategy for Monitoring Laser Thermal Therapy Based on Changes in Optothermal Properties of Heated Tissues" *International Journal of Thermophysics* vol. 26., No. 1, pp. 233-241.
- Thomsen, Sharon et al. (1990) "Microscopic Correlates of Macroscopic Optical Property Changes During Thermal Coagulation of Myocardium" *SPIE* vol. 1202, pp. 2-11.
- Khan, Misban Huzaira et al. (2005) "Intradermally Focused Infrared Laser Pulses: Thermal Effects at Defined Tissue Depths" *Lasers in Surgery and Medicine* vol. 36, pp. 270-280.
- Neumann, R.A. et al. (1991) "Enzyme Histochemical Analysis of Cell Viability After Argon Laser-Induced Coagulation Necrosis of the Skin" *Journal of the American Academy of Dermatology* vol. 25, No. 6, pp. 991-998.
- Nadkarni, Seemantini K. et al (2005) "Characterization of Atherosclerotic Plaques by Laser Speckle Imaging" *Circulation* vol. 112, pp. 885-892.
- Zimnyakov, Dmitry A. et al (2002) "Speckle-Contrast Monitoring of Tissue Thermal Modification" *Applied Optics* vol. 41, No. 28, pp. 5989-5996.
- Morelli, J.G., et al (1986) "Tunable Dye Laser (577 nm) Treatment of Port Wine Stains" *Lasers in Surgery and Medicine* vol. 6, pp. 94-99.
- French, P.M.W. et al. (1993) "Continuous-wave Mode-Locked Cr⁴⁺: YAG Laser" *Optics Letters* vol. 18, No. 1, pp. 39-41.
- Sennaroglu, Alphan et al. (1995) "Efficient Continuous-Wave Chromium-Doped YAG Laser" *Journal of Optical Society of America* vol. 12, No. 5, pp. 930-937.
- Bouma, B et al. (1994) "Hybrid Mode Locking of a Flash-Lamp-Pumped Ti: Al₂O₃ Laser" *Optics Letters* vol. 19, No. 22, pp. 1858-1860.
- Bouma, B et al. (1995) "High Resolution Optical Coherence Tomography Imaging Using a Mode-Locked Ti: Al₂O₃ Laser Source" *Optics Letters* vol. 20, No. 13, pp. 1486-1488.
- Liptak David C. et al., (2007) "On the Development of a Confocal Rayleigh-Brillouin Microscope" *American Institute of Physics* vol. 78.
- Office Action mailed Oct. 1, 2008 for U.S. Appl. No. 11/955,986.
- Invitation of Pay Additional Fees mailed Aug. 7, 2008 for International Application No. PCT/US2008/062354.
- Invitation of Pay Additional Fees mailed Jul. 20, 2008 for International Application No. PCT/US2007/081982.
- International Search Report and Written Opinion mailed Mar. 7, 2006 for PCT/US2005/035711.
- International Search Report and Written Opinion mailed Jul. 18, 2008 for PCT/US2008/057533.
- Aizu, Y et al. (1991) "Bio-Speckle Phenomena and Their Application to the Evaluation of Blood Flow" *Optics and Laser Technology*, vol. 23, No. 4, Aug. 1, 1991.
- Richards G.J. et al. (1997) "Laser Speckle Contrast Analysis (LASCA): A Technique for Measuring Capillary Blood Flow Using the First Order Statistics of Laser Speckle Patterns" Apr. 2, 1997.
- Gonick, Maria M., et al (2002) "Visualization of Blood Microcirculation Parameters in Human Tissues by Time Integrated Dynamic Speckles Analysis" vol. 972, No. 1, Oct. 1, 2002.
- International Search Report and Written Opinion mailed Jul. 4, 2008 for PCT/US2008/051432.
- Jonathan, Enock (2005) "Dual Reference Arm Low-Coherence Interferometer-Based Reflectometer for Optical Coherence Tomography (OCT) Application" *Optics Communications* vol. 252.
- Motaghian Nezam, S.M.R. (2007) "increased Ranging Depth in optical Frequency Domain Imaging by Frequency Encoding" *Optics Letters*, vol. 32, No. 19, Oct. 1, 2007.
- Office Action dated Jun. 30, 2008 for U.S. Appl. No. 11/670,058.
- Office Action dated Jul. 7, 2008 for U.S. Appl. No. 10/551,735.
- Australian Examiner's Report mailed May 27, 2008 for Australian patent application No. 2003210669.
- Notice of Allowance mailed Jun. 4, 2008 for U.S. Appl. No. 11/174,425.
- European communication dated May 15, 2008 for European patent application No. 05819917.5.
- International Search Report and Written Opinion mailed Jun. 10, 2008 for PCT/US2008/051335.
- Oh, W.Y. et al (2006) "Ultrahigh-Speed Optical Frequency Domain Imaging and Application to laser Ablation Monitoring" *Applied Physics Letters*, vol. 88.
- Office Action dated Aug. 21, 2008 for U.S. Appl. No. 11/505,700.
- Sticker, Markus (2002) En Face Imaging of Single Cell layers by Differential Phase-Contrast Optical Coherence Microscopy) *Optics Letters*, col. 27, No. 13, Jul. 1, 2002.
- International Search Report and Written Opinion dated Jul. 17, 2008 for International Application No. PCT/US2008/057450.
- International Search Report and Written Opinion dated Aug. 11, 2008 for International Application No. PCT/US2008/058703.
- US National Library of Medicine (NLM), Bethesda, MD, US; Oct. 2007, "Abstracts of the 19th Annual Symposium of Transcatheter Cardiovascular Therapeutics, Oct. 20-25, 2007, Washington, DC, USA."
- International Search Report and Written Opinion dated May 26, 2008 for International Application No. PCT/US2008/051404.
- Office Action dated Aug. 25, 2008 for U.S. Appl. No. 11/264,655.
- Office Action dated Sep. 11, 2008 for U.S. Appl. No. 11/624,334.
- Office Action dated Aug. 21, 2008 for U.S. Appl. No. 11/956,079.
- Gelikono, V. M. et al. (Oct. 1, "Two-Wavelength Optical Coherence Tomography" *Radio physics and Quantum Electronics, Kluwer Academic Publishers-Consultants*. vol. 47, No. 10-1.
- International Search Report and Written Opinion for PCT/US2007/081982 dated Oct. 19, 2007.
- Database Compendex Engineering Information, Inc., New York, NY, US; Mar. 5, 2007, Yelin, Dvir et al: "Spectral-Domain Spectrally-Encoded Endoscopy".
- Database Biosis Biosciences Information Service, Philadelphia, PA, US; Oct. 2006, Yelin D. et al: "Three-Dimensional Miniature Endoscopy".
- International Search Report and Written Opinion mailed Mar. 14, 2005 for PCT/US2004/018045.
- Notification of the international Preliminary Report on Patentability mailed Oct. 21, 2005.

(56)

References Cited

OTHER PUBLICATIONS

- Shim M.G. et al., "Study of Fiber-Optic Probes for In vivo Medical Raman Spectroscopy" *Applied Spectroscopy*, vol. 53, No. 6, Jun. 1999.
- Bingid U. et al., "Fibre-Optic Laser-Assisted Infrared Tumour Diagnostics (FLAIR); Infrared Tumour Diagnostics" *Journal of Physics D. Applied Physics*, vol. 38, No. 15, Aug. 7, 2005.
- Jun Zhang et al. "Full Range Polarization-Sensitive Fourier Domain Optical Coherence Tomography" *Optics Express*, vol. 12, No. 24, Nov. 29, 2004.
- Yonghua et al., "Real-Time Phase-Resolved Functional Optical Hilbert Transformation" *Optics Letters*, vol. 27, No. 2, Jan. 15, 2002.
- Siavash et al., "Self-Referenced Doppler Optical Coherence Tomography" *Optics Letters*, vol. 27, No. 23, Dec. 1, 2002.
- International Search Report and Written Opinion dated Dec. 20, 2004 for PCT/US04/10152.
- Notification Concerning Transmittal of International Preliminary Report on Patentability dated Oct. 13, 2005 for PCT/US04/10152.
- International Search Report and Written Opinion dated Mar. 23, 2006 for PCT/US2005/042408.
- International Preliminary Report on Patentability dated Jun. 7, 2007 for PCT/US2005/042408.
- International Search Report and Written Opinion dated Feb. 28, 2007 for International Application No. PCT/US2006/038277.
- International Search Report and Written Opinion dated Jan. 30, 2009 for International Application No. PCT/US2008/081834.
- International Search Report and Written Opinion dated Feb. 2, 2009 for International Application No. PCT/US2008/071786.
- Bilenca A et al: "The Role of Amplitude and phase in Fluorescence Coherence Imaging: From Wide Filed to Nanometer Depth Profiling", *Optics IEEE*, May 5, 2007.
- Inoue, Yusuke et al: "Variable Phase-Contrast Fluorescence Spectrometry for Fluorescently Strained Cells", *Applied Physics Letters*, Sep. 18, 2006.
- Bernet, S et al: "Quantitative Imaging of Complex Samples by Spiral Phase Contrast Microscopy", *Optics Express*, May 9, 2006.
- International Search Report and Written Opinion dated Jan. 15, 2009 for International Application No. PCT/US2008/074863.
- Office Action dated Feb. 17, 2009 for U.S. Appl. No. 11/211,483.
- Notice of Reasons for Rejection mailed Dec. 2, 2008 for Japanese patent application No. 2000-533782.
- International Search Report and Written Opinion dated Feb. 24, 2009 for PCT/US2008/076447.
- Fujimoto et al., "High Resolution in Vivo Intra-Arterial Imaging with Optical Coherence Tomography," *Official Journal of the British Cardiac Society*, vol. 82, pp. 128-133 Heart, 1999.
- D. Huang et al., "Optical Coherence Tomography," *Science*, vol. 254, pp. 1178-1181, Nov. 1991.
- Tearney et al., "High-Speed Phase- and Group Delay Scanning with a Grating Based Phase Control Delay Line," *Optics Letters*, vol. 22, pp. 1811-1813, Dec. 1997.
- Rollins, et al., "In Vivo Video Rate Optical Coherence Tomography," *Optics Express*, vol. 3, pp. 219-229, Sep. 1998.
- Saxer, et al., High Speed Fiber-Based Polarization-Sensitive Optical Coherence Tomography of in Vivo Human Skin, *Optical Society of America*, vol. 25, pp. 1355-1357, Sep. 2000.
- Oscar Eduardo Martinez, "3000 Times Grating Compress or with Positive Group Velocity Dispersion," *IEEE*, vol. QE-23, pp. 59-64, Jan. 1987.
- Kulkarni, et al., "Image Enhancement in Optical Coherence Tomography Using Deconvolution," *Electronics Letters*, vol. 33, pp. 1365-1367, Jul. 1997.
- Bashkansky, et al., "Signal Processing for Improving Field Cross-Correlation Function in Optical Coherence Tomography," *Optics & Photonics News*, vol. 9, pp. 8137-8138, May 1998.
- Yung et al., "Phase-Domain Processing of Optical Coherence Tomography Images," *Journal of Biomedical Optics*, vol. 4, pp. 125-136, Jan. 1999.
- Tearney, et al., "In Vivo Endoscopic Optical Biopsy with Optical Coherence Tomography," *Science*, vol. 276, Jun. 1997.
- W. Drexler et al., "In Vivo Ultrahigh-Resolution Optical Coherence Tomography," *Optics Letters* vol. 24, pp. 1221-1223, Sep. 1999
- Nicusor V. Iftimia et al., "A Portable, Low Coherence Interferometry Based Instrument for Fine Needle Aspiration Biopsy Guidance," Accepted to Review of Scientific Instruments, 2005.
- Abbas, G.L., V.W.S. Chan et al., "Local-Oscillator Excess-Noise Suppression for Homodyne and Heterodyne-Detection," *Optics Letters*, vol. 8, pp. 419-421, Aug. 1983 issue.
- Agrawal, G.P., "Population Pulsations and Nondegenerate 4-Wave Mixing in Semiconductor-Lasers and Amplifiers," *Journal of the Optical Society of America B-Optical Physics*, vol. 5, pp. 147-159, Jan. 1998.
- Andretzky, P. et al., "Optical Coherence Tomography by Spectral Radar: Improvement of Signal-to-Noise Ratio," *The International Society for Optical Engineering*, USA, vol. 3915, 2000.
- Ballif, J. et al., "Rapid and Scalable Scans at 21 m/s in optical Low-Coherence Reflectometry," *Optics Letters*, vol. 22, pp. 757-759, Jun. 1997.
- Barfuss H. et al., "Modified Optical Frequency-Domain Reflectometry with High Spatial-Resolution for Components of Integrated Optic Systems," *Journal of Lightwave Technology*, vol. 7, pp. 3-10, Jan. 1989.
- Beaud, P. et al., "Optical Reflectometry with Micrometer Resolution for the Investigation of Integrated Optical-Devices," *IEEE Journal of Quantum Electronics*, vol. 25, pp. 755-759, Apr. 1989.
- Bouma, Brett et al., "Power-Efficient Nonreciprocal Interferometer and Linear-Scanning Fiber-Optic Catheter for Optical Coherence Tomography," *Optics Letters*, vol. 24, pp. 531-533, Apr. 1999.
- Brinkmeyer, E. et al., "Efficient Algorithm for Non-Equidistant Interpolation of Sampled Data," *Electronics Letters*, vol. 28, p. 693, Mar. 1992.
- Brinkmeyer, E. et al., "High-Resolution OADR in Dispersive Wave-Guides," *Electronics Letters*, vol. 26, pp. 413-414, Mar. 1990.
- Chinn, S.R. et al., "Optical Coherence Tomography Using a Frequency-Tunable Optical Source," *Optics Letters*, vol. 22, pp. 340-342, Mar. 1997.
- Danielson, B.L. et al., "Absolute Optical Ranging Using Low Coherence Interferometry," *Applied Optics*, vol. 30, p. 2975, Jul. 1991.
- Dorrer, C. et al., "Spectral Resolution and Sampling Issues in Fourier-Transform Spectral Interferometry," *Journal of the Optical Society of America B-Optical Physics*, vol. 17, pp. 1795-1802, Oct. 2000.
- Dudley, J.M. et al., "Cross-Correlation Frequency Resolved Optical Gating Analysis of Broadband Continuum Generation in Photonic Crystal Fiber: Simulations and Experiments," *Optics Express*, vol. 10, p. 1215, Oct. 2002.
- Eickhoff, W. et al., "Optical Frequency-Domain Reflectometry in Single-Mode Fiber," *Applied Physics Letters*, vol. 39, pp. 693-695, 1981.
- Fercher, Adolf "Optical Coherence Tomography," *Journal of Biomedical Optics*, vol. 1, pp. 157-173, Apr. 1996.
- Ferreira, L.A. et al., "Polarization-Insensitive Fiberoptic White-Light Interferometry," *Optics Communications*, vol. 114, pp. 386-392, Feb. 1995.
- Fujii, Yohji, "High-Isolation Polarization-Independent Optical Circulator", *Journal of Lightwave Technology*, vol. 9, pp. 1239-1243, Oct. 1991.
- Glance, B., "Polarization Independent Coherent Optical Receiver," *Journal of Lightwave Technology*, vol. LT-5, p. 274, Feb. 1987.
- Glombitza, U., "Coherent Frequency-Domain Reflectometry for Characterization of Single-Mode Integrated-Optical Wave-Guides," *Journal of Lightwave Technology*, vol. 11, pp. 1377-1384, Aug. 1993.
- Golubovic, B. et al., "Optical Frequency-Domain Reflectometry Using Rapid Wavelength Tuning of a Cr⁴⁺:Forsterite Laser," *Optics Letters*, vol. 11, pp. 1704-1706, Nov. 1997.
- Haberland, U. H. P. et al., "Chirp Optical Coherence Tomography of Layered Scattering Media," *Journal of Biomedical Optics*, vol. 3, pp. 259-266, Jul. 1998.
- Hammer, Daniel X. et al., "Spectrally Resolved White-Light Interferometry for Measurement of Ocular Dispersion," *Journal of the Optical Society of America A-Optics Image Science and Vision*, vol. 16, pp. 2092-2102, Sep. 1999.

(56)

References Cited

OTHER PUBLICATIONS

- Harvey, K. C. et al., "External-Cavity Diode-Laser Using a Grazing-Incidence Diffraction Grating," *Optics Letters*, vol. 16, pp. 910-912, Jun. 1991.
- Hausler, Gerd et al., "'Coherence Radar' and 'Spectral Radar' New Tools for Dermatological Diagnosis," *Journal of Biomedical Optics*, vol. 3, pp. 21-31, Jan. 1998.
- Hee, Michael R. et al., "Polarization-Sensitive Low-Coherence Reflectometer for Birefringence Characterization and Ranging," *Journal of the Optical Society of America B (Optical Physics)*, vol. 9, p. 903-908, Jun. 1992.
- Hotate Kazuo et al., "Optical Coherence Domain Reflectometry by Synthesis of Coherence Function," *Journal of Lightwave Technology*, vol. 11, pp. 1701-1710, Oct. 1993.
- Inoue, Kyo et al., "Nearly Degenerate 4-Wave-Mixing in a Traveling-Wave Semiconductor-Laser Amplifier," *Applied Physics Letters*, vol. 51, pp. 1051-1053, 1987.
- Ivanov, A. P. et al., "New Method for High-Range Resolution Measurements of Light Scattering in Optically Dense Inhomogeneous Media," *Optics Letters*, vol. 1, pp. 226-228, Dec. 1977.
- Ivanov, A. P. et al., "Interferometric Study of the Spatial Structure of a Light-Scattering Medium," *Journal of Applied Spectroscopy*, vol. 28, pp. 518-525, 1978.
- Kazovsky, L. G. et al., "Heterodyne Detection Through Rain, Snow, and Turbid Media: Effective Receiver Size at Optical Through Millimeter Wavelengths," *Applied Optics*, vol. 22, pp. 706-710, Mar. 1983.
- Kersey, A. D. et al., "Adaptive Polarization Diversity Receiver Configuration for Coherent Optical Fiber Communications," *Electronics Letters*, vol. 25, pp. 275-277, Feb. 1989.
- Kohlhaas, Andreas et al., "High-Resolution OADR for Testing Integrated-Optical Waveguides: Dispersion-Corrupted Experimental Data Corrected by a Numerical Algorithm," *Journal of Lightwave Technology*, vol. 9, pp. 1493-1502, Nov. 1991.
- Larkin, Kieran G., "Efficient Nonlinear Algorithm for Envelope Detection in White Light Interferometry," *Journal of the Optical Society of America A-Optics Image Science and Vision*, vol. 13, pp. 832-843, Apr. 1996.
- Leitgeb, R. et al., "Spectral measurement of Absorption by Spectroscopic Frequency-Domain Optical Coherence Tomography," *Optics Letters*, vol. 25, pp. 820-822, Jun. 2000.
- Lexer, F. et al., "Wavelength-Tuning Interferometry of Intraocular Distances," *Applied Optics*, vol. 36, pp. 6548-6553, Sep. 1997.
- Mitsui, Takahisa, "Dynamic Range of Optical Reflectometry with Spectral Interferometry," *Japanese Journal of Applied Physics Part 1—Regular Papers Short Notes & Review Papers*, vol. 38, pp. 6133-6137, 1999.
- Naganuma, Kazunori et al., "Group-Delay Measurement Using the Fourier-Transform of an Interferometric Cross-Correlation Generated by White Light," *Optics Letters*, vol. 15, p. 393-395, Apr. 1990.
- Okoshi, Takanori, "Polarization-State Control Schemes for Heterodyne or Homodyne Optical Fiber Communications," *Journal of Lightwave Technology*, vol. LT-3, pp. 1232-1237, Dec. 1995.
- Passy, R. et al., "Experimental and Theoretical Investigations of Coherent OFDR with Semiconductor-Laser Sources," *Journal of Lightwave Technology*, vol. 12, pp. 1622-1630, Sep. 1994.
- Podoleanu, Adrian G., "Unbalanced Versus Balanced Operation in an Optical Coherence Tomography System," *Applied Optics*, vol. 39, pp. 173-182, Jan. 2000.
- Price, J. H. V. et al., "Tunable, Femtosecond Pulse Source Operating in the Range 1.06-1.33 μm Based on an Yb³⁺-doped Holey Fiber Amplifier," *Journal of the Optical Society of America B—Optical Physics*, vol. 19, pp. 1286-1294, Jun. 2002.
- Schmitt, J. M. et al., "Measurement of Optical-Properties of Biological Tissues by Low-Coherence Reflectometry," *Applied Optics*, vol. 32, pp. 6032-6042, Oct. 1993.
- Silberberg, Y. et al., "Passive-Mode Locking of a Semiconductor Diode-Laser," *Optics Letters*, vol. 9, pp. 507-509, Nov. 1984.
- Smith, L. Montgomery et al., "Absolute Displacement Measurements Using Modulation of the Spectrum of White-Light in a Michelson Interferometer," *Applied Optics*, vol. 28, pp. 3339-3342, Aug. 1989.
- Sonnenschein, C. M. et al., "Signal-To-Noise Relationships for Coaxial Systems that Heterodyne Backscatter from Atmosphere," *Applied Optics*, vol. 10, pp. 1600-1604, Jul. 1971.
- Sorin, W. V. et al., "Measurement of Rayleigh Backscattering at 1.55 μm with 32 μm Spatial Resolution," *IEEE Photonics Technology Letters*, vol. 4, pp. 374-376, Apr. 1992.
- Sorin, W. V. et al., "A Simple Intensity Noise-Reduction Technique for Optical Low-Coherence Reflectometry," *IEEE Photonics Technology Letters*, vol. 4, pp. 1404-1406, Dec. 1992.
- Swanson, E. A. et al., "High-Speed Optical Coherence Domain Reflectometry," *Optics Letters*, vol. 17, pp. 151-153, Jan. 1992.
- Takada, K. et al., "High-Resolution OFDR with Incorporated Fiberoptic Frequency Encoder," *IEEE Photonics Technology Letters*, vol. 4, pp. 1069-1072, Sep. 1992.
- Takada, Kazumasa et al., "Narrow-Band light Source with Acoustooptic Tunable Filter for Optical Low-Coherence Reflectometry," *IEEE Photonics Technology Letters*, vol. 8, pp. 658-660, May 1996.
- Takada, Kazumasa et al., "New Measurement System for Fault Location in Optical Wave-Guide Devices Based on an Interometric-Technique," *Applied Optics*, vol. 26, pp. 1603-1606, May 1987.
- Tateda, Mitsuhiro et al., "Interferometric Method for Chromatic Dispersion Measurement in a Single-Mode Optical Fiber," *IEEE Journal of Quantum Electronics*, vol. 17, pp. 404-407, Mar. 1981.
- Toide, M. et al., "Two-Dimensional Coherent Detection Imaging in Multiple Scattering Media Based the Directional Resolution Capability of the Optical Heterodyne Method," *Applied Physics B (Photophysics and Laser Chemistry)*, vol. B52, pp. 391-394, 1991.
- Trutna, W. R. et al., "Continuously Tuned External-Cavity Semiconductor-Laser," *Journal of Lightwave Technology*, vol. 11, pp. 1279-1286, Aug. 1993.
- Uttam, Deepak et al., "Precision Time Domain Reflectometry in Optical Fiber Systems Using a Frequency Modulated Continuous Wave Ranging Technique," *Journal of Lightwave Technology*, vol. 3, pp. 971-977, Oct. 1985.
- Von Der Weid, J. P. et al., "On the Characterization of Optical Fiber Network Components with Optical Frequency Domain Reflectometry," *Journal of Lightwave Technology*, vol. 15, pp. 1131-1141, Jul. 1997.
- Wysocki, P.F. et al., "Broad-Spectrum, Wavelength-Swept, Erbium-Doped Fiber Laser at 1.55- μm ," *Optics Letters*, vol. 15, pp. 879-881, Aug. 1990.
- Youngquist, Robert C. et al., "Optical Coherence-Domain Reflectometry—A New Optical Evaluation Technique," *Optics Letters*, vol. 12, pp. 158-160, Mar. 1987.
- Yun, S. H. et al., "Wavelength-Swept Fiber Laser with Frequency Shifted Feedback and Resonantly Swept Intra-Cavity Acoustooptic Tunable Filter," *IEEE Journal of Selected Topics in Quantum Electronics*, vol. 3, pp. 1087-1096, Aug. 1997.
- Yun, S. H. et al., "Interrogation of Fiber Grating Sensor Arrays with a Wavelength-Swept Fiber Laser," *Optics Letters*, vol. 23, pp. 843-845, Jun. 1998.
- Yung, K. M., "Phase-Domain Processing of Optical Coherence Tomography Images," *Journal of Biomedical Optics*, vol. 4, pp. 125-136, Jan. 1999.
- Zhou, Xiao-Qun et al., "Extended-Range FMCW Reflectometry Using an optical Loop with a Frequency Shifter," *IEEE Photonics Technology Letters*, vol. 8, pp. 248-250, Feb. 1996.
- Zorabedian, Paul et al., "Tuning Fidelity of Acoustooptically Controlled External Cavity Semiconductor-Lasers," *Journal of Lightwave Technology*, vol. 13, pp. 62-66, Jan. 1995.
- Victor S. Y. Lin et al., "A Porous Silicon-Based Optical Interferometric Biosensor," *Science Magazine*, vol. 278, pp. 840-843, Oct. 31, 1997.
- De Boer, Johannes F. et al., "Review of Polarization Sensitive Optical Coherence Tomography and Stokes Vector Determination," *Journal of Biomedical Optics*, vol. 7, No. 3, Jul. 2002, pp. 359-371.
- Jiao, Shuliang et al., "Depth-Resolved Two-Dimensional Stokes Vectors of Backscattered Light and Mueller Matrices of Biological Tis-

(56)

References Cited

OTHER PUBLICATIONS

- sue Measured with Optical Coherence Tomography," *Applied Optics*, vol. 39, No. 34, Dec. 1, 2000, pp. 6318-6324.
- Park, B. Hyle et al., "In Vivo Burn Depth Determination by High-Speed Fiber-Based Polarization Sensitive Optical Coherence Tomography," *Journal of Biomedical Optics*, vol. 6 No. 4, Oct. 2001, pp. 474-479.
- Roth, Jonathan E. et al., "Simplified Method for Polarization-Sensitive Optical Coherence Tomography," *Optics Letters*, vol. 26, No. 14, Jul. 15, 2001, pp. 1069-1071.
- Hitzenberger, Christopher K. et al., "Measurement and Imaging of Birefringence and Optic Axis Orientation by Phase Resolved Polarization Sensitive Optical Coherence Tomography," *Optics Express*, vol. 9, No. 13, Dec. 17, 2001, pp. 780-790.
- Wang, Xueding et al., "Propagation of Polarized Light in Birefringent Turbid Media: Time-Resolved Simulations," Optical Imaging Laboratory, Biomedical Engineering Program, Texas A&M University.
- Wong, Brian J.F. et al., "Optical Coherence Tomography of the Rat Cochlea," *Journal of Biomedical Optics*, vol. 5, No. 4, Oct. 2000, pp. 367-370.
- Yao, Gang et al., "Propagation of Polarized Light in Turbid Media: Simulated Animation Sequences," *Optics Express*, vol. 7, No. 5, Aug. 28, 2000, pp. 198-203.
- Wang, Xiao-Jun et al., "Characterization of Dentin and Enamel by Use of Optical Coherence Tomography," *Applied Optics*, vol. 38, No. 10, Apr. 1, 1999, pp. 2092-2096.
- De Boer, Johannes F. et al., "Determination of the Depth-Resolved Stokes Parameters of Light Backscattered from Turbid Media by use of Polarization-Sensitive Optical Coherence Tomography," *Optics Letters*, vol. 24, No. 5, Mar. 1, 1999, pp. 300-302.
- Ducros, Mathieu G. et al., "Polarization Sensitive Optical Coherence Tomography of the Rabbit Eye," *IEEE Journal of Selected Topics in Quantum Electronics*, vol. 5, No. 4, Jul./Aug. 1999, pp. 1159-1167.
- Groner, Warren et al., "Orthogonal Polarization Spectral Imaging: A New Method for Study of the Microcirculation," *Nature Medicine Inc.*, vol. 5 No. 10, Oct. 1999, pp. 1209-1213.
- De Boer, Johannes F. et al., "Polarization Effects in Optical Coherence Tomography of Various Viological Tissues," *IEEE Journal of Selected Topics in Quantum Electronics*, vol. 5, No. 4, Jul./Aug. 1999, pp. 1200-1204.
- Yao, Gang et al., "Two-Dimensional Depth-Resolved Mueller Matrix Characterization of Biological Tissue by Optical Coherence Tomography," *Optics Letters*, Apr. 15, 1999, vol. 24, No. 8, pp. 537-539.
- Lu, Shih-Yau et al., "Homogeneous and Inhomogeneous Jones Matrices," *J. Opt. Soc. Am. A.*, vol. 11, No. 2, Feb. 1994, pp. 766-773.
- Bickel, S. William et al., "Stokes Vectors, Mueller Matrices, and Polarized Scattered Light," *Am. J. Phys.*, vol. 53, No. 5, May 1985 pp. 468-478.
- Bréhonnet, F. Le Roy et al., "Optical Media and Target Characterization by Mueller Matrix Decomposition," *J. Phys. D: Appl. Phys.* 29, 1996, pp. 34-38.
- Cameron, Brent D. et al., "Measurement and Calculation of the Two-Dimensional Backscattering Mueller Matrix of a Turbid Medium," *Optics Letters*, vol. 23, No. 7, Apr. 1, 1998, pp. 485-487.
- De Boer, Johannes F. et al., "Two-Dimensional Birefringence Imaging in Biological Tissue by Polarization-Sensitive Optical Coherence Tomography," *Optics Letters*, vol. 22, No. 12, Jun. 15, 1997, pp. 934-936.
- De Boer, Johannes F. et al., "Imaging Thermally Damaged Tissue by Polarization Sensitive Optical Coherence Tomography," *Optics Express*, vol. 3, No. 6, Sep. 14, 1998, pp. 212-218.
- Everett, M.J. et al., "Birefringence Characterization of Biological Tissue by Use of Optical Coherence Tomography," *Optics Letters*, vol. 23, No. 3, Feb. 1, 1998, pp. 228-230.
- Hee, Michael R. et al., "Polarization-Sensitive Low-Coherence Reflectometer for Birefringence Characterization and Ranging," *J. Opt. Soc. Am. B.*, vol. 9, No. 6, Jun. 1992, pp. 903-908.
- Barakat, Richard, "Statistics of the Stokes Parameters," *J. Opt. Soc. Am. B.*, vol. 4, No. 7, Jul. 1987, pp. 1256-1263.
- Schmitt, J.M. et al., "Cross-Polarized Backscatter in Optical Coherence Tomography of Biological Tissue," *Optics Letters*, vol. 23, No. 13, Jul. 1, 1998, pp. 1060-1062.
- Schoenenberger, Klaus et al., "Mapping of Birefringence and Thermal Damage in Tissue by use of Polarization-Sensitive Optical Coherence Tomography," *Applied Optics*, vol. 37, No. 25, Sep. 1, 1998, pp. 6026-6036.
- Pierce, Mark C. et al., "Simultaneous Intensity, Birefringence, and Flow Measurements with High-Speed Fiber-Based Optical Coherence Tomography," *Optics Letters*, vol. 27, No. 17, Sep. 1, 2002, pp. 1534-1536.
- De Boer, Johannes F. et al., "Review of Polarization Sensitive Optical Coherence Tomography and Stokes Vector Determination," *Journal of Biomedical Optics*, Jul. 2002, vol. 7, No. 3, pp. 359-371.
- Fried, Daniel et al., "Imaging Caries Lesions and Lesion Progression with Polarization Sensitive Optical Coherence Tomography," *Journal of Biomedical Optics*, vol. 7, No. 4, Oct. 2002, pp. 618-627.
- Jiao, Shuliang et al., "Two-Dimensional Depth-Resolved Mueller Matrix of Biological Tissue Measured with Double-Beam Polarization-Sensitive Optical Coherence Tomography," *Optics Letters*, vol. 27, No. 2, Jan. 15, 2002, pp. 101-103.
- Jiao, Shuliang et al., "Jones-Matrix Imaging of Biological Tissues with Quadruple-Channel Optical Coherence Tomography," *Journal of Biomedical Optics*, vol. 7, No. 3, Jul. 2002, pp. 350-358.
- Kuranov, R.V. et al., "Complementary Use of Cross-Polarization and Standard OCT for Differential Diagnosis of Pathological Tissues," *Optics Express*, vol. 10, No. 15, Jul. 29, 2002, pp. 707-713.
- Cense, Barry et al., "In Vivo Depth-Resolved Birefringence Measurements of the Human Retinal Nerve Fiber Layer by Polarization-Sensitive Optical Coherence Tomography," *Optics Letters*, vol. 27, No. 18, Sep. 15, 2002, pp. 1610-1612.
- Ren, Hongwu et al., "Phase-Resolved Functional Optical Coherence Tomography: Simultaneous Imaging of In Situ Tissue Structure, Blood Flow Velocity, Standard Deviation, Birefringence, and Stokes Vectors in Human Skin," *Optics Letters*, vol. 27, No. 19, Oct. 1, 2002, pp. 1702-1704.
- Tripathi, Renu et al., "Spectral Shaping for Non-Gaussian Source Spectra in Optical Coherence Tomography," *Optics Letters*, vol. 27, No. 6, Mar. 15, 2002, pp. 406-408.
- Yasuno, Y. et al., "Birefringence Imaging of Human Skin by Polarization-Sensitive Spectral Interferometric Optical Coherence Tomography," *Optics Letters*, vol. 27, No. 20, Oct. 15, 2002 pp. 1803-1805.
- White, Brian R. et al., "In Vivo Dynamic Human Retinal Blood Flow Imaging Using Ultra-High-Speed Spectral Domain Optical Doppler Tomography," *Optics Express*, vol. 11, No. 25, Dec. 15, 2003, pp. 3490-3497.
- De Boer, Johannes F. et al., "Improved Signal-to-Noise Ratio in Spectral-Domain Compared with Time-Domain Optical Coherence Tomography," *Optics Letters*, vol. 28, No. 21, Nov. 1, 2003, pp. 2067-2069.
- Jiao, Shuliang et al., "Optical-Fiber-Based Mueller Optical Coherence Tomography," *Optics Letters*, vol. 28, No. 14, Jul. 15, 2003, pp. 1206-1208.
- Jiao, Shuliang et al., "Contrast Mechanisms in Polarization-Sensitive Mueller-Matrix Optical Coherence Tomography and Application in Burn Imaging," *Applied Optics*, vol. 42, No. 25, Sep. 1, 2003, pp. 5191-5197.
- Moreau, Julien et al., "Full-Field Birefringence Imaging by Thermal-Light Polarization-Sensitive Optical Coherence Tomography. I. Theory," *Applied Optics*, vol. 42, No. 19, Jul. 1, 2003, pp. 3800-3810.
- Moreau, Julien et al., "Full-Field Birefringence Imaging by Thermal-Light Polarization-Sensitive Optical Coherence Tomography. II. Instrument and Results," *Applied Optics*, vol. 42, No. 19, Jul. 1, 2003, pp. 3811-3818.
- Morgan, Stephen P. et al., "Surface-Reflection Elimination in Polarization Imaging of Superficial Tissue," *Optics Letters*, vol. 28, No. 2, Jan. 15, 2003, pp. 114-116.
- Oh, Jung-Taek et al., "Polarization-Sensitive Optical Coherence Tomography for Photoelasticity Testing of Glass/Epoxy Composites," *Optics Express*, vol. 11, No. 14, Jul. 14, 2003, pp. 1669-1676.

(56)

References Cited

OTHER PUBLICATIONS

- Park, B. Hyle et al., "Real-Time Multi-Functional Optical Coherence Tomography," *Optics Express*, vol. 11, No. 7, Apr. 7, 2003, pp. 782-793.
- Shribak, Michael et al., "Techniques for Fast and Sensitive Measurements of Two-Dimensional Birefringence Distributions," *Applied Optics*, vol. 42, No. 16, Jun. 1, 2003, pp. 3009-3017.
- Somervell, A.R.D. et al., "Direct Measurement of Fringe Amplitude and Phase Using a Heterodyne Interferometer Operating in Broad-band Light," *Elsevier, Optics Communications*, Oct. 2003.
- Stifter, D. et al., "Polarisation-Sensitive Optical Coherence Tomography for Material Characterisation and Strain-Field Mapping," *Applied Physics A 76, Materials Science & Processing*, Jan. 2003, pp. 947-951.
- Davé, Digant P. et al., "Polarization-Maintaining Fiber-Based Optical Low-Coherence Reflectometer for Characterization and Ranging of Birefringence," *Optics Letters*, vol. 28, No. 19, Oct. 1, 2003, pp. 1775-1777.
- Yang, Ying et al., "Observations of Birefringence in Tissues from Optic-Fibre-Based Optical Coherence Tomography," *Measurement Science and Technology*, Nov. 2002, pp. 41-46.
- Yun, S.H. et al., "High-Speed Optical Frequency-Domain Imaging," *Optics Express*, vol. 11, No. 22, Nov. 3, 2003, pp. 2953-2963.
- Yun, S.H. et al., "High-Speed Spectral-Domain Optical Coherence Tomography at 1.3 μm Wavelength," *Optics Express*, vol. 11, No. 26, Dec. 29, 2003, pp. 3598-3604.
- Zhang, Jun et al., "Determination of Birefringence and Absolute Optic Axis Orientation Using Polarization-Sensitive Optical Coherence Tomography with PM Fibers," *Optics Express*, vol. 11, No. 24, Dec. 1, 2003, pp. 3262-3270.
- Pircher, Michael et al., "Three Dimensional Polarization Sensitive OCT of Human Skin In Vivo," 2004, *Optical Society of America*.
- Götzinger, Erich et al., "Measurement and Imaging of Birefringent Properties of the Human Cornea with Phase-Resolved, Polarization-Sensitive Optical Coherence Tomography," *Journal of Biomedical Optics*, vol. 9, No. 1, Jan./Feb. 2004, pp. 94-102.
- Guo, Shuguang et al., "Depth-Resolved Birefringence and Differential Optical Axis Orientation Measurements with Finer-based Polarization-Sensitive Optical Coherence Tomography," *Optics Letters*, vol. 29, No. 17, Sep. 1, 2004, pp. 2025-2027.
- Huang, Xiang-Run et al., "Variation of Peripapillary Retinal Nerve Fiber Layer Birefringence in Normal Human Subjects," *Investigative Ophthalmology & Visual Science*, vol. 45, No. 9, Sep. 2004, pp. 3073-3080.
- Matcher, Stephen J. et al., "The Collagen Structure of Bovine Intervertebral Disc Studied Using Polarization-Sensitive Optical Coherence Tomography," *Physics in Medicine and Biology*, 2004, pp. 1295-1306.
- Nassif, Nader et al., "In Vivo Human Retinal Imaging by Ultrahigh-Speed Spectral Domain Optical Coherence Tomography," *Optics Letters*, vol. 29, No. 5, Mar. 1, 2004, pp. 480-482.
- Nassif, N.A. et al., "In Vivo High-Resolution Video-Rate Spectral-Domain Optical Coherence Tomography of the Human Retina and Optic Nerve," *Optics Express*, vol. 12, No. 3, Feb. 9, 2004, pp. 367-376.
- Park, B. Hyle et al., Comment on "Optical-Fiber-Based Mueller Optical Coherence Tomography," *Optics Letters*, vol. 29, No. 24, Dec. 15, 2004, pp. 2873-2874.
- Park, B. Hyle et al., "Jones Matrix Analysis for a Polarization-Sensitive Optical Coherence Tomography System Using Fiber-Optic Components," *Optics Letters*, vol. 29, No. 21, Nov. 1, 2004, pp. 2512-2514.
- Pierce, Mark C. et al., "Collagen Denaturation can be Quantified in Burned Human Skin Using Polarization-Sensitive Optical Coherence Tomography," *Elsevier, Burns*, 2004, pp. 511-517.
- Pierce, Mark C. et al., "Advances in Optical Coherence Tomography Imaging for Dermatology," *The Society for Investigative Dermatology, Inc.* 2004, pp. 458-463.
- Pierce, Mark C. et al., "Birefringence Measurements in Human Skin Using Polarization-Sensitive Optical Coherence Tomography," *Journal of Biomedical Optics*, vol. 9, No. 2, Mar./Apr. 2004, pp. 287-291.
- Cense, Barry et al., "In Vivo Birefringence and Thickness Measurements of the Human Retinal Nerve Fiber Layer Using Polarization-Sensitive Optical Coherence Tomography," *Journal of Biomedical Optics*, vol. 9, No. 1, Jan./Feb. 2004, pp. 121-125.
- Pircher, Michael et al., "Imaging of Polarization Properties of Human Retina in Vivo with Phase Resolved Transversal PS-OCT," *Optics Express*, vol. 12, No. 24, Nov. 29, 2004 pp. 5940-5951.
- Pircher, Michael et al., "Transversal Phase Resolved Polarization Sensitive Optical Coherence Tomography," *Physics in Medicine & Biology*, 2004, pp. 1257-1263.
- Srinivas, Shyam M. et al., "Determination of Burn Depth by Polarization-Sensitive Optical Coherence Tomography," *Journal of Biomedical Optics*, vol. 9, No. 1, Jan./Feb. 2004, pp. 207-212.
- Strasswimmer, John et al., "Polarization-Sensitive Optical Coherence Tomography of Invasive Basal Cell Carcinoma," *Journal of Biomedical Optics*, vol. 9, No. 2, Mar./Apr. 2004, pp. 292-298.
- Todorovič, Miloš et al., "Determination of Local Polarization Properties of Biological Samples in the Presence of Diattenuation by use of Mueller Optical Coherence Tomography," *Optics Letters*, vol. 29, No. 20, Oct. 15, 2004, pp. 2402-2404.
- Yasuno, Yoshiaki et al., "Polarization-Sensitive Complex Fourier Domain Optical Coherence Tomography for Jones Matrix Imaging of Biological Samples," *Applied Physics Letters*, vol. 85, No. 15, Oct. 11, 2004, pp. 3023-3025.
- Acioli, L. H., M. Ulman, et al. (1991). "Femtosecond Temporal Encoding in Barium-Titanate." *Optics Letters* 16(24): 1984-1986.
- Aigouy, L., A. Lahrech, et al. (1999). "Polarization effects in apertureless scanning near-field optical microscopy: an experimental study." *Optics Letters* 24(4): 187-189.
- Akiba, M., K. P. Chan, et al. (2003). "Full-field optical coherence tomography by two-dimensional heterodyne detection with a pair of CCD cameras." *Optics Letters* 28(10): 816-818.
- Akkin, T., D. P. Dave, et al. (2004). "Detection of neural activity using phase-sensitive optical low-coherence reflectometry." *Optics Express* 12(11): 2377-2386.
- Akkin, T., D. P. Dave, et al. (2003). "Surface analysis using phase sensitive optical low coherence reflectometry." *Lasers in Surgery and Medicine*: 4-4.
- Akkin, T., D. P. Dave, et al. (2003). "Imaging tissue response to electrical and photothermal stimulation with nanometer sensitivity." *Lasers in Surgery and Medicine* 33(4): 219-225.
- Akkin, T., T. E. Milner, et al. (2002). "Phase-sensitive measurement of birefringence change as an indication of neural functionality and diseases." *Lasers in Surgery and Medicine*: 6-6.
- Andretzky, P., Lindner, M.W., Herrmann, J.M., Schultz, A., Konzog, M., Kiesewetter, F., Haeusler, G. (1999). "Optical coherence tomography by 'spectral radar': Dynamic range estimation and in vivo measurements of skin." *Proceedings of SPIE—The International Society for Optical Engineering* 3567: pp. 78-87.
- Antcliff, R. J., T. J. ffytche, et al. (2000). "Optical coherence tomography of melanocytoma." *American Journal of Ophthalmology* 130(6): 845-7.
- Antcliff, R. J., M. R. Stanford, et al. (2000). "Comparison between optical coherence tomography and fundus fluorescein angiography for the detection of cystoid macular edema in patients with uveitis." *Ophthalmology* 107(3): 593-9.
- Anvari, B., T. E. Milner, et al. (1995). "Selective Cooling of Biological Tissues—Application for Thermally Mediated Therapeutic Procedures." *Physics in Medicine and Biology* 40(2): 241-252.
- Anvari, B., B. S. Tanenbaum, et al. (1995). "A Theoretical-Study of the Thermal Response of Skin to Cryogen Spray Cooling and Pulsed-Laser Irradiation—Implications for Treatment of Port-Wine Stain Birthmarks." *Physics in Medicine and Biology* 40(9): 1451-1465.
- Arend, O., M. Ruffer, et al. (2000). "Macular circulation in patients with diabetes mellitus with and without arterial hypertension." *British Journal of Ophthalmology* 84(12): 1392-1396.
- Arimoto, H. and Y. Ohtsuka (1997). "Measurements of the complex degree of spectral coherence by use of a wave-front-folded interferometer." *Optics Letters* 22(13): 958-960.

(56)

References Cited

OTHER PUBLICATIONS

- Azzolini, C., F. Patelli, et al. (2001). "Correlation between optical coherence tomography data and biomicroscopic interpretation of idiopathic macular hole." *American Journal of Ophthalmology* 132(3): 348-55.
- Baba, T., K. Ohno-Matsui, et al. (2002). "Optical coherence tomography of choroidal neovascularization in high myopia." *Acta Ophthalmologica Scandinavica* 80(1): 82-7.
- Bail, M. A. H., Gerd; Herrmann, Juergen M.; Lindner, Michael W.; Ringler, R. (1996). "Optical coherence tomography with the "spectral radar": fast optical analysis in volume scatterers by short-coherence interferometry." *Proc. SPIE*, 2925: p. 298-303.
- Baney, D. M. and W. V. Sorin (1993). "Extended-Range Optical Low-Coherence Reflectometry Using a Recirculating Delay Technique." *Ieee Photonics Technology Letters* 5(9): 1109-1112.
- Baney, D. M., B. Szafraniec, et al. (2002). "Coherent optical spectrum analyzer." *Ieee Photonics Technology Letters* 14(3): 355-357.
- Barakat, R. (1981). "Bilinear Constraints between Elements of the 4by4 Mueller-Jones Transfer-Matrix of Polarization Theory." *Optics Communications* 38(3): 159-161.
- Barakat, R. (1993). "Analytic Proofs of the Arago-Fresnel Laws for the Interference of Polarized-Light." *Journal of the Optical Society of America a-Optics Image Science and Vision* 10(1): 180-185.
- Barbastathis, G. and D. J. Brady (1999). "Multidimensional tomographic imaging using volume holography." *Proceedings of the IEEE* 87(12): 2098-2120.
- Bardal, S., A. Kamal, et al. (1992). "Photoinduced Birefringence in Optical Fibers—a Comparative-Study of Low-Birefringence and High-Birefringence Fibers." *Optics Letters* 17(6): 411-413.
- Barsky, S. H., S. Rosen, et al. (1980). "Nature and Evolution of Port Wine Stains—Computer-Assisted Study." *Journal of Investigative Dermatology* 74(3): 154-157.
- Barton, J. K., J. A. Izatt, et al. (1999). "Three-dimensional reconstruction of blood vessels from in vivo color Doppler optical coherence tomography images." *Dermatology* 198(4): 355-361.
- Barton, J. K., A. Rollins, et al. (2001). "Photothermal coagulation of blood vessels: a comparison of high-speed optical coherence tomography and numerical modelling." *Physics in Medicine and Biology* 46.
- Barton, J. K., A. J. Welch, et al. (1998). "Investigating pulsed dye laser-blood vessel interaction with color Doppler optical coherence tomography." *Optics Express* 3.
- Bashkansky, M., M. D. Duncan, et al. (1997). "Subsurface defect detection in ceramics by high-speed high-resolution optical coherent tomography." *Optics Letters* 22 (1): 61-63.
- Bashkansky, M. and J. Reintjes (2000). "Statistics and reduction of speckle in optical coherence tomography." *Optics Letters* 25(8): 545-547.
- Baumgartner, A., S. Dichtl, et al. (2000). "Polarization-sensitive optical coherence tomography of dental structures." *Caries Research* 34(1): 59-69.
- Baumgartner, A., C. K. Hitzenberger, et al. (2000). "Resolution-improved dual-beam and standard optical coherence tomography: a comparison." *Graefes Archive for Clinical and Experimental Ophthalmology* 238(5): 385-392.
- Baumgartner, A., C. K. Hitzenberger, et al. (1998). "Signal and resolution enhancements in dual beam optical coherence tomography of the human eye." *Journal of Biomedical Optics* 3(1): 45-54.
- Beaurepaire, E., P. Gleyzes, et al. (1998). *Optical coherence microscopy for the in-depth study of biological structures: System based on a parallel detection scheme*, Proceedings of SPIE—The International Society for Optical Engineering.
- Beaurepaire, E., L. Moreaux, et al. (1999). "Combined scanning optical coherence and two-photon-excited fluorescence microscopy." *Optics Letters* 24(14): 969-971.
- Bechara, F. G., T. Gambichler, et al. (2004). "Histomorphologic correlation with routine histology and optical coherence tomography." *Skin Research and Technology* 10 (3): 169-173.
- Bechmann, M., M. J. Thiel, et al. (2000). "Central corneal thickness determined with optical coherence tomography in various types of glaucoma. [see comments]." *British Journal of Ophthalmology* 84(11): 1233-7.
- Bek, T. and M. Kandi (2000). "Quantitative anomaloscopy and optical coherence tomography scanning in central serous chorioretinopathy." *Acta Ophthalmologica Scandinavica* 78(6): 632-7.
- Benoit, A. M., K. Naoun, et al. (2001). "Linear dichroism of the retinal nerve fiber layer expressed with Mueller matrices." *Applied Optics* 40(4): 565-569.
- Bicout, D., C. Brosseau, et al. (1994). "Depolarization of Multiply Scattered Waves by Spherical Diffusers—Influence of the Size Parameter." *Physical Review E* 49(2): 1767-1770.
- Blanchot, L., M. Lebec, et al. (1997). *Low-coherence in depth microscopy for biological tissues imaging: Design of a real time control system*, Proceedings of SPIE—The International Society for Optical Engineering.
- Blumenthal, E. Z. and R. N. Weinreb (2001). "Assessment of the retinal nerve fiber layer in clinical trials of glaucoma neuroprotection. [Review] [36 refs]." *Survey of Ophthalmology* 45(Suppl 3): S305-12; discussion S332-4.
- Blumenthal, E. Z., J. M. Williams, et al. (2000). "Reproducibility of nerve fiber layer thickness measurements by use of optical coherence tomography." *Ophthalmology* 107(12): 2278-82.
- Boppart, S. A., B. E. Bouma, et al. (1996). "Imaging developing neural morphology using optical coherence tomography." *Journal of Neuroscience Methods* 70.
- Boppart, S. A., B. E. Bouma, et al. (1997). "Forward-imaging instruments for optical coherence tomography." *Optics Letters* 22.
- Boppart, S. A., B. E. Bouma, et al. (1998). "Intraoperative assessment of microsurgery with three-dimensional optical coherence tomography." *Radiology* 208: 81-86.
- Boppart, S. A., J. Herrmann, et al. (1999). "High-resolution optical coherence tomography-guided laser ablation of surgical tissue." *Journal of Surgical Research* 82(2): 275-84.
- Bouma, B. E. and J. G. Fujimoto (1996). "Compact Kerr-lens mode-locked resonators." *Optics Letters* 21. 134-136.
- Bouma, B. E., L. E. Nelson, et al. (1998). "Optical coherence tomographic imaging of human tissue at 1.55 μm and 1.81 μm using Er and Tm-doped fiber sources." *Journal of Biomedical Optics* 3. 76-79.
- Bouma, B. E., M. Ramaswamy-Paye, et al. (1997). "Compact resonator designs for mode-locked solid-state lasers." *Applied Physics B (Lasers and Optics)* B65. 213-220.
- Bouma, B. E. and G. J. Tearney (2002). "Clinical imaging with optical coherence tomography." *Academic Radiology* 9(8): 942-953.
- Bouma, B. E., G. J. Tearney, et al. (1996). "Self-phase-modulated Kerr-lens mode-locked Cr:forsterite laser source for optical coherence tomography." *Optics Letters* 21(22): 1839.
- Bouma, B. E., G. J. Tearney, et al. (2000). "High-resolution imaging of the human esophagus and stomach in vivo using optical coherence tomography." *Gastrointestinal Endoscopy* 51(4): 467-474.
- Bouma, B. E., G. J. Tearney, et al. (2003). "Evaluation of intracoronary stenting by intravascular optical coherence tomography." *Heart* 89(3): 317-320.
- Bourquin, S., V. Monterosso, et al. (2000). "Video-rate optical low-coherence reflectometry based on a linear smart detector array." *Optics Letters* 25(2): 102-104.
- Bourquin, S., P. Seitz, et al. (2001). "Optical coherence topography based on a two-dimensional smart detector array." *Optics Letters* 26(8): 512-514.
- Bouzid, A., M. A. G. Abushagur, et al. (1995). "Fiber-optic four-detector polarimeter." *Optics Communications* 118(3-4): 329-334.
- Bowd, C., R. N. Weinreb, et al. (2000). "The retinal nerve fiber layer thickness in ocular hypertensive, normal, and glaucomatous eyes with optical coherence tomography." *Archives of Ophthalmology* 118(1): 22-6.
- Bowd, C., L. M. Zangwill, et al. (2001). "Detecting early glaucoma by assessment of retinal nerve fiber layer thickness and visual function." *Investigative Ophthalmology & Visual Science* 42(9): 1993-2003.

(56)

References Cited

OTHER PUBLICATIONS

- Bowd, C., L. M. Zangwill, et al. (2002). "Imaging of the optic disc and retinal nerve fiber layer: the effects of age, optic disc area, refractive error, and gender." *Journal of the Optical Society of America, A, Optics, Image Science, & Vision* 19(1): 197-207.
- Brand, S., J. M. Poneros, et al. (2000). "Optical coherence tomography in the gastrointestinal tract." *Endoscopy* 32(10): 796-803.
- Brezinski, M. E. and J. G. Fujimoto (1999). "Optical coherence tomography: high-resolution imaging in nontransparent tissue." *IEEE Journal of Selected Topics in Quantum Electronics* 5(4): 1185-1192.
- Brezinski, M. E., G. J. Tearney, et al. (1996). "Imaging of coronary artery microstructure (in vitro) with optical coherence tomography." *American Journal of Cardiology* 77 (1): 92-93.
- Brezinski, M. E., G. J. Tearney, et al. (1996). "Optical coherence tomography for optical biopsy—Properties and demonstration of vascular pathology." *Circulation* 93(6): 1206-1213.
- Brezinski, M. E., G. J. Tearney, et al. (1997). "Assessing atherosclerotic plaque morphology: Comparison of optical coherence tomography and high frequency intravascular ultrasound." *Heart* 77(5): 397-403.
- Brink, H. B. K. and G. J. Vanbloklund (1988). "Birefringence of the Human Foveal Area Assessed In vivo with Mueller-Matrix Ellipsometry." *Journal of the Optical Society of America a-Optics Image Science and Vision* 5(1): 49-57.
- Brosseau, C. and D. Bicoût (1994). "Entropy Production in Multiple-Scattering of Light by a Spatially Random Medium." *Physical Review E* 50(6): 4997-5005.
- Burgoyne, C. F., D. E. Mercante, et al. (2002). "Change detection in regional and volumetric disc parameters using longitudinal confocal scanning laser tomography." *Ophthalmology* 109(3): 455-66.
- Candido, R. and T. J. Allen (2002). "Haemodynamics in microvascular complications in type 1 diabetes." *Diabetes-Metabolism Research and Reviews* 18(4): 286-304.
- Cense, B., T. C. Chen, et al. (2004). "Thickness and birefringence of healthy retinal nerve fiber layer tissue measured with polarization-sensitive optical coherence tomography." *Investigative Ophthalmology & Visual Science* 45(8): 2606-2612.
- Cense, B., N. Nassif, et al. (2004). "Ultrahigh-Resolution High-Speed Retinal Imaging Using Spectral-Domain Optical Coherence Tomography." *Optics Express* 12(11): 2435-2447.
- Chance, B., J. S. Leigh, et al. (1988). "Comparison of Time-Resolved and Time-Unresolved Measurements of Deoxyhemoglobin in Brain." *Proceedings of the National Academy of Sciences of the United States of America* 85(14): 4971-4975.
- Chang, E. P., D. A. Keedy, et al. (1974). "Ultrastructures of Rabbit Corneal Stroma—Mapping of Optical and Morphological Anisotropies." *Biochimica Et Biophysica Acta* 343(3): 615-626.
- Chartier, T., A. Hideur, et al. (2001). "Measurement of the elliptical birefringence of single-mode optical fibers." *Applied Optics* 40(30): 5343-5353.
- Chauhan, B. C., J. W. Blanchard, et al. (2000). "Technique for Detecting Serial Topographic Changes in the Optic Disc and Peripapillary Retina Using Scanning Laser Tomograph." *Invest Ophthalmol Vis Sci* 41: 775-782.
- Chen, Z. P., T. E. Milner, et al. (1997). "Optical Doppler tomographic imaging of fluid flow velocity in highly scattering media." *Optics Letters* 22(1): 64-66.
- Chen, Z. P., T. E. Milner, et al. (1997). "Noninvasive imaging of in vivo blood flow velocity using optical Doppler tomography." *Optics Letters* 22(14): 1119-1121.
- Chen, Z. P., Y. H. Zhao, et al. (1999). "Optical Doppler tomography." *Ieee Journal of Selected Topics in Quantum Electronics* 5(4): 1134-1142.
- Cheong, W. F., S. A. Prael, et al. (1990). "A Review of the Optical-Properties of Biological Tissues." *Ieee Journal of Quantum Electronics* 26(12): 2166-2185.
- Chernikov, S. V., Y. Zhu, et al. (1997). "Supercontinuum self-Q-switched ytterbium fiber laser." *Optics Letters* 22(5): 298-300.
- Cho, S. H., B. E. Bouma, et al. (1999). "Low-repetition-rate high-peak-power Kerr-lens mode-locked Ti:Al/sub 2/0/sub 3/ laser with a multiple-pass cavity." *Optics Letters* 24(6): 417-419.
- Choma, M. A., M. V. Sarunic, et al. (2003). "Sensitivity advantage of swept source and Fourier domain optical coherence tomography." *Optics Express* 11(18): 2183-2189.
- Choma, M. A., C. H. Yang, et al. (2003). "Instantaneous quadrature low-coherence interferometry with 3 × 3 fiber-optic couplers." *Optics Letters* 28(22): 2162-2164.
- Choplin, N. T. and D. C. Lundy (2001). "The sensitivity and specificity of scanning laser polarimetry in the detection of glaucoma in a clinical setting." *Ophthalmology* 108 (5): 899-904.
- Christens Barry, W. A., W. J. Green, et al. (1996). "Spatial mapping of polarized light transmission in the central rabbit cornea." *Experimental Eye Research* 62(6): 651-662.
- Chvapil, M., D. P. Speer, et al. (1984). "Identification of the depth of burn injury by collagen stainability." *Plastic & Reconstructive Surgery* 73(3): 438-41.
- Cioffi, G. A. (2001). "Three common assumptions about ocular blood flow and glaucoma." *Survey of Ophthalmology* 45: S325-S331.
- Coleman, A. L. (1999). "Glaucoma." *Lancet* 354(9192): 1803-10.
- Collaborative Normal-Tension Glaucoma Study Group (1998). "Comparison of Glaucomatous Progression Between Untreated Patients With Normal Tension Glaucoma and Patients with Therapeutically Reduced Intraocular Pressures." *Am J Ophthalmol* 126: 487-97.
- Collaborative Normal-Tension Glaucoma Study Group (1998). "The effectiveness of intraocular pressure reduction in the treatment of normal-tension glaucoma." *Am J Ophthalmol* 126: 498-505.
- Collaborative Normal-Tension Glaucoma Study Group (2001). "Natural History of Normal-Tension Glaucoma." *Ophthalmology* 108: 247-253.
- Colston, B. W., M. J. Everett, et al. (1998). "Imaging of hard- and soft-tissue structure in the oral cavity by optical coherence tomography." *Applied Optics* 37(16): 3582-3585.
- Colston, B. W., U. S. Sathyam, et al. (1998). "Dental OCT." *Optics Express* 3(6): 230-238.
- Congdon, N. G., D. S. Friedman, et al. (2003). "Important causes of visual impairment in the world today." *Jama-Journal of the American Medical Association* 290(15): 2057-2060.
- Cregan, R. F., B. J. Mangan, et al. (1999). "Single-mode photonic band gap guidance of light in air." *Science* 285(5433): 1537-1539.
- DalMolin, M., A. Galtarossa, et al. (1997). "Experimental investigation of linear polarization in high-birefringence single-mode fibers." *Applied Optics* 36(12): 2526-2528.
- Danielson, B. L. and C. D. Whittenberg (1987). "Guided-Wave Reflectometry with Micrometer Resolution." *Applied Optics* 26(14): 2836-2842.
- Dave, D. P. and T. E. Milner (2000). "Doppler-angle measurement in highly scattering media." *Optics Letters* 25(20): 1523-1525.
- de Boer, J. F., T. E. Milner, et al. (1998). *Two dimensional birefringence imaging in biological tissue using phase and polarization sensitive optical coherence tomography*. Trends in Optics and Photonics (TOPS): Advances in Optical Imaging and Photon Migration, Orlando, USA, Optical Society of America, Washington, DC 1998.
- de Boer, J. F., C. E. Saxer, et al. (2001). "Stable carrier generation and phase-resolved digital data processing in optical coherence tomography." *Applied Optics* 40(31): 5787-5790.
- Degroot, P. and L. Deck (1993). "3-Dimensional Imaging by Sub-Nyquist Sampling of White-Light Interferograms." *Optics Letters* 18(17): 1462-1464.
- Denk, W., J. H. Strickler, et al. (1990). "2-Photon Laser Scanning Fluorescence Microscopy." *Science* 248(4951): 73-76.
- Descour, M. R., A. H. O. Karkkainen, et al. (2002). "Toward the development of miniaturized Imaging systems for detection of precancer." *Ieee Journal of Quantum Electronics* 38(2): 122-130.
- Dettwiller, L. (1997). "Polarization state interference: A general investigation." *Pure and Applied Optics* 6(1): 41-53.
- DiCarlo, C. D., W. P. Roach, et al. (1999). "Comparison of optical coherence tomography imaging of cataracts with histopathology." *Journal of Biomedical Optics* 4.

(56)

References Cited

OTHER PUBLICATIONS

- Ding, Z., Y. Zhao, et al. (2002). "Real-time phase-resolved optical coherence tomography and optical Doppler tomography." *Optics Express* 10(5): 236-245.
- Dobrin, P. B. (1996). "Effect of histologic preparation on the cross-sectional area of arterial rings." *Journal of Surgical Research* 61(2): 413-5.
- Donohue, D. J., B. J. Stoyanov, et al. (1995). "Numerical Modeling of the Corneas Lamellar Structure and Birefringence Properties." *Journal of the Optical Society of America a-Optics Image Science and Vision* 12(7): 1425-1438.
- Doornbos, R. M. P., R. Lang, et al. (1999). "The determination of in vivo human tissue optical properties and absolute chromophore concentrations using spatially resolved steady-state diffuse reflectance spectroscopy." *Physics in Medicine and Biology* 44(4): 967-981.
- Drexler, W., A. Baumgartner, et al. (1997). "Biometric investigation of changes in the anterior eye segment during accommodation." *Vision Research* 37(19): 2789-2800.
- Drexler, W., A. Baumgartner, et al. (1997). "Submicrometer precision biometry of the anterior segment of the human eye." *Investigative Ophthalmology & Visual Science* 38(7): 1304-1313.
- Drexler, W., A. Baumgartner, et al. (1998). "Dual beam optical coherence tomography: signal identification for ophthalmologic diagnosis." *Journal of Biomedical Optics* 3 (1): 55-65.
- Drexler, W., O. Findl, et al. (1998). "Partial coherence interferometry: A novel approach to biometry in cataract surgery." *American Journal of Ophthalmology* 126(4): 524-534.
- Drexler, W., O. Findl, et al. (1997). "Clinical feasibility of dual beam optical coherence topography and tomography for ophthalmologic diagnosis." *Investigative Ophthalmology & Visual Science* 38(4): 1038-1038.
- Drexler, W., C. K. Hitzenberger, et al. (1998). "Investigation of dispersion effects in ocular media by multiple wavelength partial coherence interferometry." *Experimental Eye Research* 66(1): 25-33.
- Drexler, W., C. K. Hitzenberger, et al. (1996). "(Sub)micrometer precision biometry of the human eye by optical coherence tomography and topography." *Investigative Ophthalmology & Visual Science* 37(3): 4374-4374.
- Drexler, W., C. K. Hitzenberger, et al. (1995). "Measurement of the Thickness of Fundus Layers by Partial Coherence Tomography." *Optical Engineering* 34(3): 701-710.
- Drexler, W., U. Morgner, et al. (2001). "Ultrahigh-resolution ophthalmic optical coherence tomography." *Nature Medicine* 7(4): 502-507.
- Drexler, W., U. Morgner, et al. (2001). "Ultrahigh-resolution ophthalmic optical coherence tomography. [erratum appears in Nat Med May 2001;7(5):636.]" *Nature Medicine* 7(4): 502-7.
- Drexler, W., H. Sattmann, et al. (2003). "Enhanced visualization of macular pathology with the use of ultrahigh-resolution optical coherence tomography." *Archives of Ophthalmology* 121(5): 695-706.
- Drexler, W., D. Stamper, et al. (2001). "Correlation of collagen organization with polarization sensitive imaging of in vitro cartilage: implications for osteoarthritis." *Journal of Rheumatology* 28(6): 1311-8.
- Droog, E. J., W. Steenbergen, et al. (2001). "Measurement of depth of burns by laser Doppler perfusion imaging." *Burns* 27(6): 561-8.
- Dubois, A., K. Grieve, et al. (2004). "Ultrahigh-resolution full-field optical coherence tomography." *Applied Optics* 43(14): 2874-2883.
- Dubois, A., L. Vabre, et al. (2002). "High-resolution full-field optical coherence tomography with a Linnik microscope." *Applied Optics* 41(4): 805-812.
- Ducros, M., M. Laubscher, et al. (2002). "Parallel optical coherence tomography in scattering samples using a two-dimensional smart-pixel detector array." *Optics Communications* 202(1-3): 29-35.
- Ducros, M. G., J. D. Marsack, et al. (2001). "Primate retina imaging with polarization-sensitive optical coherence tomography." *Journal of the Optical Society of America a-Optics Image Science and Vision* 18(12): 2945-2956.
- Duncan, A., J. H. Meek, et al. (1995). "Optical Pathlength Measurements on Adult Head, Calf and Forearm and the Head of the New-born-Infant Using Phase-Resolved Optical Spectroscopy." *Physics in Medicine and Biology* 40(2): 295-304.
- Eigensee, A., G. Haeusler, et al. (1996). "New method of short-coherence interferometry in human skin (in vivo) and in solid volume scatterers." *Proceedings of SPIE—The International Society for Optical Engineering* 2925: 169-178.
- Eisenbeiss, W., J. Marotz, et al. (1999). "Reflection-optical multispectral imaging method for objective determination of burn depth." *Burns* 25(8): 697-704.
- Elbaum, M., M. King, et al. (1972). "Wavelength-Diversity Technique for Reduction of Speckle Size." *Journal of the Optical Society of America* 62(5): 732-&.
- Ervin, J. C., H. G. Lemij, et al. (2002). "Clinician change detection viewing longitudinal stereophotographs compared to confocal scanning laser tomography in the LSU Experimental Glaucoma (LEG) Study." *Ophthalmology* 109(3): 467-81.
- Essenpreis, M., C. E. Elwell, et al. (1993). "Spectral Dependence of Temporal Point Spread Functions in Human Tissues." *Applied Optics* 32(4): 418-425.
- Eun, H. C. (1995). "Evaluation of skin blood flow by laser Doppler flowmetry. [Review] [151 refs]." *Clinics in Dermatology* 13(4): 337-47.
- Evans, J. A., J. M. Ponerros, et al. (2004). "Application of a histopathologic scoring system to optical coherence tomography (OCT) images to identify high-grade dysplasia in Barrett's esophagus." *Gastroenterology* 126(4): A51-A51.
- Feldchtein, F. I., G. V. Gelikonov, et al. (1998). "In vivo OCT imaging of hard and soft tissue of the oral cavity." *Optics Express* 3(6): 239-250.
- Feldchtein, F. I., G. V. Gelikonov, et al. (1998). "Endoscopic applications of optical coherence tomography." *Optics Express* 3(6): 257-270.
- Fercher, A. F., W. Drexler, et al. (1997). "Optical ocular tomography." *Neuro-Ophthalmology* 18(2): 39-49.
- Fercher, A. F., W. Drexler, et al. (1994). *Measurement of optical distances by optical spectrum modulation*. Proceedings of SPIE—The International Society for Optical Engineering.
- Fercher, A. F., W. Drexler, et al. (2003). "Optical coherence tomography—principles and applications." *Reports on Progress in Physics* 66(2): 239-303.
- Fercher, A. F., C. K. Hitzenberger, et al. (1991). "Measurement of Intraocular Optical Distances Using Partially Coherent Laser-Light." *Journal of Modern Optics* 38(7): 1327-1333.
- Fercher, A. F., C. K. Hitzenberger, et al. (1996). *Ocular partial coherence interferometry*. Proceedings of SPIE—The International Society for Optical Engineering.
- Fercher, A. F., C. K. Hitzenberger, et al. (1993). "In-Vivo Optical Coherence Tomography." *American Journal of Ophthalmology* 116(1): 113-115.
- Fercher, A. F., C. K. Hitzenberger, et al. (1994). *In-vivo dual-beam optical coherence tomography*. Proceedings of SPIE—The International Society for Optical Engineering.
- Fercher, A. F., C. K. Hitzenberger, et al. (1995). "Measurement of Intraocular Distances by Backscattering Spectral Interferometry." *Optics Communications* 117(1-2): 43-48.
- Fercher, A. F., C. K. Hitzenberger, et al. (2000). "A thermal light source technique for optical coherence tomography." *Optics Communications* 185(1-3): 57-64.
- Fercher, A. F., C. K. Hitzenberger, et al. (2001). "Numerical dispersion compensation for Partial Coherence Interferometry and Optical Coherence Tomography." *Optics Express* 9(12): 610-615.
- Fercher, A. F., C. K. Hitzenberger, et al. (2002). "Dispersion compensation for optical coherence tomography depth-scan signals by a numerical technique." *Optics Communications* 204(1-6): 67-74.
- Fercher, A. F., H. C. Li, et al. (1993). "Slit Lamp Laser-Doppler Interferometer." *Lasers in Surgery and Medicine* 13(4): 447-452.
- Fercher, A. F., K. Mengedoh, et al. (1988). "Eye-Length Measurement by Interferometry with Partially Coherent-Light." *Optics Letters* 13(3): 186-188.
- Ferro, P., M. Haelterman, et al. (1991). "All-Optical Polarization Switch with Long Low-Birefringence Fiber." *Electronics Letters* 27(16): 1407-1408.

(56)

References Cited

OTHER PUBLICATIONS

- Fetterman, M. R., D. Goswami, et al. (1998). "Ultrafast pulse shaping: amplification and characterization." *Optics Express* 3(10): 366-375.
- Findl, O., W. Drexler, et al. (2001). "Improved prediction of intraocular lens power using partial coherence interferometry." *Journal of Cataract and Refractive Surgery* 27 (6): 861-867.
- Fork, R. L., C. H. B. Cruz, et al. (1987). "Compression of Optical Pulses to 6 Femtoseconds by Using Cubic Phase Compensation." *Optics Letters* 12(7): 483-485.
- Foschini, G. J. and C. D. Poole (1991). "Statistical-Theory of Polarization Dispersion in Single-Mode Fibers." *Journal of Lightwave Technology* 9(11): 1439-1456.
- Francia, C., F. Bruyere, et al. (1998). "PMD second-order effects on pulse propagation in single-mode optical fibers." *Ieee Photonics Technology Letters* 10(12): 1739-1741.
- Fried, D., R. E. Glens, et al. (1995). "Nature of Light-Scattering in Dental Enamel and Dentin at Visible and near-Infrared Wavelengths." *Applied Optics* 34(7): 1278-1285.
- Fujimoto, J. G., M. E. Brezinski, et al. (1995). "Optical Biopsy and Imaging Using Optical Coherence Tomography." *Nature Medicine* 1(9): 970-972.
- Fukasawa, A. and H. Iijima (2002). "Optical coherence tomography of choroidal osteoma." *American Journal of Ophthalmology* 133(3): 419-21.
- Fymat, A. L. (1981). "High-Resolution Interferometric Spectrophotopolarimetry." *Optical Engineering* 20(1): 25-30.
- Galtarossa, A., L. Palmieri, et al. (2000). "Statistical characterization of fiber random birefringence." *Optics Letters* 25(18): 1322-1324.
- Galtarossa, A., L. Palmieri, et al. (2000). "Measurements of beat length and perturbation length in long single-mode fibers." *Optics Letters* 25(6): 384-386.
- Gandjbakhche, A. H., P. Mills, et al. (1994). "Light-Scattering Technique for the Study of Orientation and Deformation of Red-Blood-Cells in a Concentrated Suspension." *Applied Optics* 33(6): 1070-1078.
- Garcia, N. and M. Nieto-Vesperinas (2002). "Left-handed materials do not make a perfect lens." *Physical Review Letters* 88(20).
- Gelikonov, V. M., G. V. Gelikonov, et al. (1995). "Coherent Optical Tomography of Microscopic Inhomogeneities in Biological Tissues." *Jetp Letters* 61(2): 158-162.
- George, N. and A. Jain (1973). "Speckle Reduction Using Multiple Tones of Illumination." *Applied Optics* 12(6): 1202-1212.
- Gibson, G. N., R. Klank, et al. (1996). "Electro-optically cavity-dumped ultrashort-pulse Ti:sapphire oscillator." *Optics Letters* 21(14): 1055.
- Gil, J. J. (2000). "Characteristic properties of Mueller matrices." *Journal of the Optical Society of America a-Optics Image Science and Vision* 17(2): 328-334.
- Gil, J. J. and E. Bernabeu (1987). "Obtainment of the Polarizing and Retardation Parameters of a Nondepolarizing Optical-System from the Polar Decomposition of Its Mueller Matrix." *Optik* 76(2): 67-71.
- Gladkova, N. D., G. A. Petrova, et al. (2000). "In vivo optical coherence tomography imaging of human skin: norm and pathology." *Skin Research and Technology* 6 (1): 6-16.
- Glaessl, A., A. G. Schreyer, et al. (2001). "Laser surgical planning with magnetic resonance imaging-based 3-dimensional reconstructions for intralesional Nd: YAG laser therapy of a venous malformation of the neck." *Archives of Dermatology* 137(10): 1331-1335.
- Gloesmann, M., B. Hermann, et al. (2003). "Histologic correlation of pig retina radial stratification with ultrahigh-resolution optical coherence tomography." *Investigative Ophthalmology & Visual Science* 44(4): 1696-1703.
- Goldberg, L. and D. Mehuys (1994). "High-Power Superluminescent Diode Source." *Electronics Letters* 30(20): 1682-1684.
- Goldsmith, J. A., Y. Li, et al. (2005). "Anterior chamber width measurement by high speed optical coherence tomography." *Ophthalmology* 112(2): 238-244.
- Goldstein, L. E., J. A. Muffat, et al. (2003). "Cytosolic beta-amyloid deposition and supranuclear cataracts in lenses from people with Alzheimer's disease." *Lancet* 361(9365): 1258-1265.
- Golubovic, B., B. E. Bouma, et al. (1996). "Thin crystal, room-temperature Cr/sup 4 +/-forstefite laser using near-infrared pumping." *Optics Letters* 21(24): 1993-1995.
- Gonzalez, S. and Z. Tannous (2002). "Real-time, in vivo confocal reflectance microscopy of basal cell carcinoma." *Journal of the American Academy of Dermatology* 47(6): 869-874.
- Gordon, M. O. and M. A. Kass (1999). "The Ocular Hypertension Treatment Study: design and baseline description of the participants." *Archives of Ophthalmology* 117(5): 573-83.
- Grayson, T. P., J. R. Torgerson, et al. (1994). "Observation of a Nonlocal Pancharatnam Phase-Shift in the Process of Induced Coherence without Induced Emission." *Physical Review A* 49(1): 626-628.
- Greaney, M. J., D. C. Hoffman, et al. (2002). "Comparison of optic nerve imaging methods to distinguish normal eyes from those with glaucoma." *Investigative Ophthalmology & Visual Science* 43(1): 140-5.
- Greenfield, D. S., H. Bagga, et al. (2003). "Macular thickness changes in glaucomatous optic neuropathy detected using optical coherence tomography." *Archives of Ophthalmology* 121(1): 41-46.
- Greenfield, D. S., R. W. Knighton, et al. "Effect of corneal polarization axis on assessment of retinal nerve fiber layer thickness by scanning laser polarimetry." *American Journal of Ophthalmology* 129(6): 715-722. (2000).
- Griffin, R. A., D. D. Sampson, et al. (1995). "Coherence Coding for Photonic Code-Division Multiple-Access Networks." *Journal of Lightwave Technology* 13(9): 1826-1837.
- Guedes, V., J. S. Schuman, et al. (2003). "Optical coherence tomography measurement of macular and nerve fiber layer thickness in normal and glaucomatous human eyes." *Ophthalmology* 110(1): 177-189.
- Gueugniaud, P. Y., H. Carsin, et al. (2000). "Current advances in the initial management of major thermal burns. [Review] [76 refs]." *Intensive Care Medicine* 26(7): 848-56.
- Guido, S. and R. T. Tranquillo (1993). "A Methodology for the Systematic and Quantitative Study of Cell Contact Guidance in Oriented Collagen Gels—Correlation of Fibroblast Orientation and Gel Birefringence." *Journal of Cell Science* 105: 317-331.
- Gurses-Ozden, R., H. Ishikawa, et al. (1999). "Increasing sampling density improves reproducibility of optical coherence tomography measurements." *Journal of Glaucoma* 8(4): 238-41.
- Guzzi, R. (1998). "Scattering Theory from Homogeneous and Coated Spheres." 1-11.
- Haberland, U. B., Vladimir; Schmitt, Hans J. (1996). "Optical coherent tomography of scattering media using electrically tunable near-infrared semiconductor laser." *Applied Optics* Draft Copy.
- Haberland, U. R., Walter; Blazek, Vladimir; Schmitt, Hans J. (1995). "Investigation of highly scattering media using near-infrared continuous wave tunable semiconductor laser." *Proc. SPIE*, 2389: 503-512.
- Hale, G. M. and M. R. Querry (1973). "Optical-Constants of Water in 200-Nm to 200-Mum Wavelength Region." *Applied Optics* 12(3): 555-563.
- Hammer, D. X., R. D. Ferguson, et al. (2002). "Image stabilization for scanning laser ophthalmoscopy." *Optics Express* 10(26): 1542.
- Hara, T., Y. Ooi, et al. (1989). "Transfer Characteristics of the Microchannel Spatial Light-Modulator." *Applied Optics* 28(22): 4781-4786.
- Harland, C. C., S. G. Kale, et al. (2000). "Differentiation of common benign pigmented skin lesions from melanoma by high-resolution ultrasound." *British Journal of Dermatology* 143(2): 281-289.
- Hartl, I., X. D. Li, et al. (2001). "Ultrahigh-resolution optical coherence tomography using continuum generation in an air-silica microstructure optical fiber." *Optics Letters* 26(9): 608-610.
- Hassenstein, A., A. A. Bialasiewicz, et al. (2000). "Optical coherence tomography in uveitis patients." *American Journal of Ophthalmology* 130(5): 669-70.
- Hattenhauer, M. G., D. H. Johnson, et al. (1998). "The probability of blindness from open-angle glaucoma. [see comments]." *Ophthalmology* 105(11): 2099-104.

(56)

References Cited

OTHER PUBLICATIONS

- Hausler, G., J. M. Herrmann, et al. (1996). "Observation of light propagation in volume scatterers with 10(11)-fold slow motion." *Optics Letters* 21(14): 1087-1089.
- Hazebroek, H. F. and A. A. Holscher (1973). "Interferometric Ellipsometry." *Journal of Physics E-Scientific Instruments* 6(9): 822-826.
- Hazebroek, H. F. and W. M. Visser (1983). "Automated Laser Interferometric Ellipsometry and Precision Reflectometry." *Journal of Physics E-Scientific Instruments* 16(7): 654-661.
- He, Z. Y., N. Mukohzaka, et al. (1997). "Selective image extraction by synthesis of the coherence function using two-dimensional optical lock-in amplifier with microchannel spatial light modulator." *Ieee Photonics Technology Letters* 9(4): 514-516.
- Hee, M. R., J. A. Izatt, et al. (1993). "Femtosecond Transillumination Optical Coherence Tomography." *Optics Letters* 18(12): 950-952.
- Hee, M. R., J. A. Izatt, et al. (1995). "Optical coherence tomography of the human retina." *Archives of Ophthalmology* 113(3): 325-32.
- Hee, M. R., C. A. Puliafito, et al. (1998). "Topography of diabetic macular edema with optical coherence tomography." *Ophthalmology* 105(2): 360-70.
- Hee, M. R., C. A. Puliafito, et al. (1995). "Quantitative assessment of macular edema with optical coherence tomography." *Archives of Ophthalmology* 113(8): 1019-29.
- Hellmuth, T. and M. Welle (1998). "Simultaneous measurement of dispersion, spectrum, and distance with a fourier transform spectrometer." *Journal of Biomedical Optics* 3(1): 7-11.
- Hemenger, R. P. (1989). "Birefringence of a medium of tenuous parallel cylinders." *Applied Optics* 28(18): 4030-4034.
- Henry, M. (1981). "Fresnel-Arago Laws for Interference in Polarized-Light—Demonstration Experiment." *American Journal of Physics* 49(7): 690-691.
- Herz, P. R., Y. Chen, et al. (2004). "Micromotor endoscope catheter for in vivo, ultrahigh-resolution optical coherence tomography." *Optics Letters* 29(19): 2261-2263.
- Hirakawa, H., H. Iijima, et al. (1999). "Optical coherence tomography of cystoid macular edema associated with retinitis pigmentosa." *American Journal of Ophthalmology* 128(2): 185-91.
- Hitzenberger, C. K., A. Baumgartner, et al. (1994). "Interferometric Measurement of Corneal Thickness with Micrometer Precision." *American Journal of Ophthalmology* 118(4): 468-476.
- Hitzenberger, C. K., A. Baumgartner, et al. (1999). "Dispersion effects in partial coherence interferometry: Implications for intraocular ranging." *Journal of Biomedical Optics* 4(1): 144-151.
- Hitzenberger, C. K., A. Baumgartner, et al. (1998). "Dispersion induced multiple signal peak splitting in partial coherence interferometry." *Optics Communications* 154 (4): 179-185.
- Hitzenberger, C. K., M. Danner, et al. (1999). "Measurement of the spatial coherence of superluminescent diodes." *Journal of Modern Optics* 46(12): 1763-1774.
- Hitzenberger, C. K. and A. F. Fercher (1999). "Differential phase contrast in optical coherence tomography." *Optics Letters* 24(9): 622-624.
- Hitzenberger, C. K., M. Sticker, et al. (2001). "Differential phase measurements in low-coherence interferometry without 2 pi ambiguity." *Optics Letters* 26(23): 1864-1866.
- Hoeling, B. M., A. D. Fernandez, et al. (2000). "An optical coherence microscope for 3-dimensional imaging in developmental biology." *Optics Express* 6(7): 136-146.
- Hoerauf, H., C. Scholz, et al. (2002). "Transscleral optical coherence tomography: a new imaging method for the anterior segment of the eye." *Archives of Ophthalmology* 120(6): 816-9.
- Hoffmann, K., M. Happe, et al. (1998). "Optical coherence tomography (OCT) in dermatology." *Journal of Investigative Dermatology* 110(4): 583-583.
- Hoh, S. T., D. S. Greenfield, et al. (2000). "Optical coherence tomography and scanning laser polarimetry in normal, ocular hypertensive, and glaucomatous eyes." *American Journal of Ophthalmology* 129(2): 129-35.
- Hohenleutner, U., M. Hilbert, et al. (1995). "Epidermal Damage and Limited Coagulation Depth with the Flashlamp-Pumped Pulsed Dye-Laser—a Histochemical-Study." *Journal of Investigative Dermatology* 104(5): 798-802.
- Holland, A. J. A., H. C. O. Martin, et al. (2002). "Laser Doppler imaging prediction of bum wound outcome in children." *Burns* 28(1): 11-17.
- Hotate, K. and T. Okugawa (1994). "Optical Information-Processing by Synthesis of the Coherence Function." *Journal of Lightwave Technology* 12(7): 1247-1255.
- Hourdakis, C. J. and A. Perris (1995). "A Monte-Carlo Estimation of Tissue Optical-Properties for Use in Laser Dosimetry." *Physics in Medicine and Biology* 40(3): 351-364.
- Hu, Z., F. Li, et al. (2000). "Wavelength-tunable narrow-linewidth semiconductor fiber-ring laser." *IEEE Photonics Technology Letters* 12(8): 977-979.
- Huang, F., W. Yang, et al. (2001). "Quadrature spectral interferometric detection and pulse shaping." *Optics Letters* 26(6): 382-384.
- Huang, X. R. and R. W. Knighton (2002). "Linear birefringence of the retinal nerve fiber layer measured in vitro with a multispectral imaging micropolarimeter." *Journal of Biomedical Optics* 7(2): 199-204.
- Huber, R., M. Wojtkowski, et al. (2005). "Amplified, frequency swept lasers for frequency domain reflectometry and OCT imaging: design and scaling principles." *Optics Express* 13(9): 3513-3528.
- Hunter, D. G., J. C. Sandruck, et al. (1999). "Mathematical modeling of retinal birefringence scanning." *Journal of the Optical Society of America a-Optics Image Science and Vision* 16(9): 2103-2111.
- Hurwitz, H. H. and R. C. Jones (1941). "A new calculus for the treatment of optical systems II. Proof of three general equivalence theorems." *Journal of the Optical Society of America* 31(7): 493-499.
- Huttner, B., C. De Barros, et al. (1999). "Polarization-induced pulse spreading in birefringent optical fibers with zero differential group delay." *Optics Letters* 24(6): 370-372.
- Huttner, B., B. Gisin, et al. (1999). "Distributed PMD measurement with a polarization-OTDR in optical fibers." *Journal of Lightwave Technology* 17(10): 1843-1848.
- Huttner, B., J. Reecht, et al. (1998). "Local birefringence measurements in single-mode fibers with coherent optical frequency-domain reflectometry." *Ieee Photonics Technology Letters* 10(10): 1458-1460.
- Hyde, S. C. W., N. P. Barry, et al. (1995). "Sub-100-Mu-M Depth-Resolved Holographic Imaging through Scattering Media in the near-Infrared." *Optics Letters* 20(22): 2330-2332.
- Hyde, S. C. W., N. P. Barry, et al. (1995). "Depth-Resolved Holographic Imaging through Scattering Media by Photorefractive." *Optics Letters* 20(11): 1331-1333.
- Iftimia, N. V., B. E. Bouma, et al. (2004). "Adaptive ranging for optical coherence tomography." *Optics Express* 12(17): 4025-4034.
- Iida, T., N. Hagimura, et al. (2000). "Evaluation of central serous chorioretinopathy with optical coherence tomography." *American Journal of Ophthalmology* 129(1): 16-20.
- Imai, M., H. Iijima, et al. (2001). "Optical coherence tomography of tractional macular elevations in eyes with proliferative diabetic retinopathy. [republished in Am J Ophthalmol. Sep. 2001;132(3):458-61 ; 11530091.]" *American Journal of Ophthalmology* 132(1): 81-4.
- Indebetouw, G. and P. Klysubun (2000). "Imaging through scattering media with depth resolution by use of low-coherence gating in spatiotemporal digital holography." *Optics Letters* 25(4): 212-214.
- Ip, M. S., B. J. Baker, et al. (2002). "Anatomical outcomes of surgery for idiopathic macular hole as determined by optical coherence tomography." *Archives of Ophthalmology* 120(1): 29-35.
- Ismail, R., V. Tanner, et al. (2002). "Optical coherence tomography imaging of severe commotio retinae and associated macular hole." *British Journal of Ophthalmology* 86(4): 473-4.
- Izatt, J. A., M. R. Hee, et al. (1994). "Optical Coherence Microscopy in Scattering Media." *Optics Letters* 19(8): 590-592.
- Izatt, J. A., M. R. Hee, et al. (1994). "Micrometer-scale resolution imaging of the anterior eye in vivo with optical coherence tomography." *Archives of Ophthalmology* 112 (12): 1584-9.

(56)

References Cited

OTHER PUBLICATIONS

- Izatt, J. A., M. D. Kulkarni, et al. (1997). "In vivo bidirectional color Doppler flow imaging of picoliter blood volumes using optical coherence tomography." *Optics Letters* 22(18): 1439-1441.
- Izatt, J. A., M. D. Kulkarni, et al. (1996). "Optical coherence tomography and microscopy in gastrointestinal tissues." *IEEE Journal of Selected Topics in Quantum Electronics* 2(4): 1017.
- Jacques, S. L., J. S. Nelson, et al. (1993). "Pulsed Photothermal Radiometry of Port-Wine-Stain Lesions." *Applied Optics* 32(13): 2439-2446.
- Jacques, S. L., J. R. Roman, et al. (2000). "Imaging superficial tissues with polarized light." *Lasers in Surgery and Medicine* 26(2): 119-129.
- Jang, I. K., B. E. Bouma, et al. (2002). "Visualization of coronary atherosclerotic plaques in patients using optical coherence tomography: Comparison with intravascular ultrasound." *Journal of the American College of Cardiology* 39(4): 604-609.
- Jang, I. K., B. D. MacNeill, et al. (2002). "In-vivo characterization of coronary plaques in patients with ST elevation acute myocardial infarction using optical coherence tomography (OCT)." *Circulation* 106(19): 698-698 3440 Suppl. S.
- Jang, I. K., G. J. Teamey, et al. (2000). "Comparison of optical coherence tomography and intravascular ultrasound for detection of coronary plaques with large lipid-core in living patients." *Circulation* 102(18): 509-509.
- Jeng, J. C., A. Bridgeman, et al. (2003). "Laser Doppler imaging determines need for excision and grafting in advance of clinical judgment: a prospective blinded trial." *Burns* 29(7): 665-670.
- Jesser, C. A., S. A. Boppart, et al. (1999). "High resolution imaging of transitional cell carcinoma with optical coherence tomography: feasibility for the evaluation of bladder pathology." *British Journal of Radiology* 72: 1170-1176.
- Johnson, C. A., J. L. Keltner, et al. (2002). "Baseline visual field characteristics in the ocular hypertension treatment study." *Ophthalmology* 109(3): 432-7.
- Jones, R. C. (1941). "A new calculus for the treatment of optical systems III. The Sohncke theory of optical activity." *Journal of the Optical Society of America* 31 (7): 500-503.
- Jones, R. C. (1941). "A new calculus for the treatment of optical systems I. Description and discussion of the calculus." *Journal of the Optical Society of America* 31(7): 488-493.
- Jones, R. C. (1942). "A new calculus for the treatment of optical systems. IV." *Journal of the Optical Society of America* 32(8): 486-493.
- Jones, R. C. (1947). "A New Calculus for the Treatment of Optical Systems .6. Experimental Determination of the Matrix." *Journal of the Optical Society of America* 37(2): 110-112.
- Jones, R. C. (1947). "A New Calculus for the Treatment of Optical Systems .5. A More General Formulation, and Description of Another Calculus." *Journal of the Optical Society of America* 37(2): 107-110.
- Jones, R. C. (1948). "A New Calculus for the Treatment of Optical Systems .7. Properties of the N-Matrices." *Journal of the Optical Society of America* 38(8): 671-685.
- Jones, R. C. (1956). "New Calculus for the Treatment of Optical Systems .8. Electromagnetic Theory." *Journal of the Optical Society of America* 46(2): 126-131.
- Jopson, R. M., L. E. Nelson, et al. (1999). "Measurement of second-order polarization-mode dispersion vectors in optical fibers." *Ieee Photonics Technology Letters* 11 (9): 1153-1155.
- Jost, B. M., A. V. Sergienko, et al. (1998). "Spatial correlations of spontaneously down-converted photon pairs detected with a single-photon-sensitive CCD camera." *Optics Express* 3(2): 81-88.
- Kaplan, B., E. Compain, et al. (2000). "Phase-modulated Mueller ellipsometry characterization of scattering by latex sphere suspensions." *Applied Optics* 39 (4): 629-636.
- Kass, M. A., D. K. Heuer, et al. (2002). "The Ocular Hypertension Treatment Study: a randomized trial determines that topical ocular hypotensive medication delays or prevents the onset of primary open-angle glaucoma." *Archives of Ophthalmology* 120(6): 701-13; discussion 829-30.
- Kasuga, Y., J. Arai, et al. (2000). "Optical coherence tomography to confirm early closure of macular holes." *American Journal of Ophthalmology* 130(5): 675-6.
- Kaufman, T., S. N. Lusthaus, et al. (1990). "Deep Partial Skin Thickness Burns—a Reproducible Animal-Model to Study Burn Wound-Healing." *Burns* 16(1): 13-16.
- Kemp, N. J., J. Park, et al. (2005). "High-sensitivity determination of birefringence in turbid media with enhanced polarization-sensitive optical coherence tomography." *Journal of the Optical Society of America a-Optics Image Science and Vision* 22(3): 552-560.
- Kerrigan-Baumrind, L. A., H. A. Quigley, et al. (2000). "Number of ganglion cells in glaucoma eyes compared with threshold visual field tests in the same persons." *Investigative Ophthalmology & Visual Science* 41(3): 741-8.
- Kesen, M. R., G. L. Spaeth, et al. (2002). "The Heidelberg Retina Tomograph vs clinical impression in the diagnosis of glaucoma." *American Journal of Ophthalmology* 133(5): 613-6.
- Kienle, A. and R. Hibst (1995). "A New Optimal Wavelength for Treatment of Port-Wine Stains." *Physics in Medicine and Biology* 40(10): 1559-1576.
- Kienle, A., L. Lilge, et al. (1996). "Spatially resolved absolute diffuse reflectance measurements for noninvasive determination of the optical scattering and absorption coefficients of biological tissue." *Applied Optics* 35(13): 2304-2314.
- Kim, B. Y. and S. S. Choi (1981). "Analysis and Measurement of Birefringence in Single-Mode Fibers Using the Backscattering Method." *Optics Letters* 6(11): 578-580.
- Kimel, S., L. O. Svaasand, et al. (1994). "Differential Vascular-Response to Laser Photothermolysis." *Journal of Investigative Dermatology* 103(5): 693-700.
- Kloppenber, F. W. H., G. Beerhuizen, et al. (2001). "Perfusion of burn wounds assessed by Laser Doppler Imaging is related to burn depth and healing time." *Burns* 27(4): 359-363.
- Knighton, R. W. and X. R. Huang (2002). "Analytical methods for scanning laser polarimetry." *Optics Express* 10(21): 1179-1189.
- Knighton, R. W., X. R. Huang, et al. (2002). "Analytical model of scanning laser polarimetry for retinal nerve fiber layer assessment." *Investigative Ophthalmology & Visual Science* 43(2): 383-392.
- Knuettel, A. R. S., Joseph M.: Shay, M.; Knutson, Jay R. (1994). "Stationary low-coherence light imaging and spectroscopy using a CCD camera." *Proc. SPIE*, vol. 2135: p. 239-250.
- Knuttel, A. and M. Boehlau-Godau (2000). "Spatially confined and temporally resolved refractive index and scattering evaluation in human skin performed with optical coherence tomography." *Journal of Biomedical Optics* 5(1): 83-92.
- Knuttel, A. and J. M. Schmitt (1993). "Stationary Depth-Profiling Reflectometer Based on Low-Coherence Interferometry." *Optics Communications* 102(3-4): 193-198.
- Knuttel, A., J. M. Schmitt, et al. (1994). "Low-Coherence Reflectometry for Stationary Lateral and Depth Profiling with Acoustooptic Deflectors and a Ccd Camera." *Optics Letters* 19(4): 302-304.
- Kobayashi, M., H. Hanafusa, et al. (1991). "Polarization-Independent Interferometric Optical-Time-Domain Reflectometer." *Journal of Lightwave Technology* 9(5): 623-628.
- Kolios, M. C., M. D. Sherar, et al. (1995). "Large Blood-Vessel Cooling in Heated Tissues—a Numerical Study." *Physics in Medicine and Biology* 40(4): 477-494.
- Koozekanani, D., K. Boyer, et al. (2001). "Retinal thickness measurements from optical coherence tomography using a Markov boundary model." *Ieee Transactions on Medical Imaging* 20(9): 900-916.
- Kop, R. H. J. and R. Sprik (1995). "Phase-sensitive interferometry with ultrashort optical pulses." *Review of Scientific Instruments* 66(12): 5459-5463.
- Kramer, R. Z., J. Bella, et al. (1999). "Sequence dependent conformational variations of collagen triple-helical structure." *Nature Structural Biology* 6(5): 454-7.

(56)

References Cited

OTHER PUBLICATIONS

- Kulkarni, M. D., T. G. van Leeuwen, et al. (1998). "Velocity-estimation accuracy and frame-rate limitations in color Doppler optical coherence tomography." *Optics Letters* 23(13): 1057-1059.
- Kwon, Y. H., C. S. Kim, et al. (2001). "Rate of visual field loss and long-term visual outcome in primary open-angle glaucoma." *American Journal of Ophthalmology* 132(1): 47-56.
- Kwong, K. F., D. Yankelevich, et al. (1993). "400-Hz Mechanical Scanning Optical Delay-Line." *Optics Letters* 18(7): 558-560.
- Landers, J., I. Goldberg, et al. (2002). "Analysis of risk factors that may be associated with progression from ocular hypertension to primary open angle glaucoma." *Clin Experiment Ophthalmology* 30(4): 242-7.
- Laszlo, A. and A. Venetianer (1998). Heat resistance in mammalian cells: Lessons and challenges. *Stress of Life*. 851: 169-178.
- Laszlo, A. and A. Venetianer (1998). "Heat resistance in mammalian cells: lessons and challenges. [Review] [52 refs]." *Annals of the New York Academy of Sciences* 851: 169-78.
- Laufer, J., R. Simpson, et al. (1998). "Effect of temperature on the optical properties of ex vivo human dermis and subdermis." *Physics in Medicine and Biology* 43(9): 2479-2489.
- Lederer, D. E., J. S. Schuman, et al. (2003). "Analysis of macular volume in normal and glaucomatous eyes using optical coherence tomography." *American Journal of Ophthalmology* 135(6): 838-843.
- Lee, P. P., Z. W. Feldman, et al. (2003). "Longitudinal prevalence of major eye diseases." *Archives of Ophthalmology* 121(9): 1303-1310.
- Lehrer, M. S., T. T. Sun, et al. (1998). "Strategies of epithelial repair: modulation of stem cell and transit amplifying cell proliferation." *Journal of Cell Science* 111(Pt 19): 2867-75.
- Leibowitz, H. M., D. E. Krueger, et al. (1980). "The Framingham Eye Study monograph: An ophthalmological and epidemiological study of cataract, glaucoma, diabetic retinopathy, macular degeneration, and visual acuity in a general population of 2631 adults, 1973-1975." *Survey of Ophthalmology* 24(Suppl): 335-610.
- Leitgeb, R., C. K. Hitzenberger, et al. (2003). "Performance of fourier domain vs. time domain optical coherence tomography." *Optics Express* 11(8): 889-894.
- Leitgeb, R., L. F. Schmetterer, et al. (2002). "Flow velocity measurements by frequency domain short coherence interferometry." *Proc. SPIE* 4619: 16-21.
- Leitgeb, R. A., W. Drexler, et al. (2004). "Ultrahigh resolution Fourier domain optical coherence tomography." *Optics Express* 12(10): 2156-2165.
- Leitgeb, R. A., C. K. Hitzenberger, et al. (2003). "Phase-shifting algorithm to achieve high-speed long-depth-range probing by frequency-domain optical coherence tomography." *Optics Letters* 28(22): 2201-2203.
- Leitgeb, R. A., L. Schmetterer, et al. (2003). "Real-time assessment of retinal blood flow with ultrafast acquisition by color Doppler Fourier domain optical coherence tomography." *Optics Express* 11(23): 3116-3121.
- Leitgeb, R. A., L. Schmetterer, et al. (2004). "Real-time measurement of in vitro flow by Fourier-domain color Doppler optical coherence tomography." *Optics Letters* 29 (2): 171-173.
- LeRoyBrehonnet, F. and B. LeJeune (1997). "Utilization of Mueller matrix formalism to obtain optical targets depolarization and polarization properties." *Progress in Quantum Electronics* 21(2): 109-151.
- Leske, M. C., A. M. Connell, et al. (1995). "Risk factors for open-angle glaucoma. The Barbados Eye Study. [see comments]." *Archives of Ophthalmology* 113(7): 918-24.
- Leske, M. C., A. M. Connell, et al. (2001). "Incidence of open-angle glaucoma: the Barbados Eye Studies. The Barbados Eye Studies Group. [see comments]." *Archives of Ophthalmology* 119(1): 89-95.
- Leske, M. C., A. Heijl, et al. (1999). "Early Manifest Glaucoma Trial. Design and Baseline Data." *Ophthalmology* 106(11): 2144-2153.
- Lewis, S. E., J. R. DeBoer, et al. (2005). "Sensitive, selective, and analytical improvements to a porous silicon gas sensor." *Sensors and Actuators B: Chemical* 110(1): 54-65.
- Lexer, F., C. K. Hitzenberger, et al. (1999). "Dynamic coherent focus OCT with depth-independent transversal resolution." *Journal of Modern Optics* 46(3): 541-553.
- Li, X., C. Chudoba, et al. (2000). "Imaging needle for optical coherence tomography." *Optics Letters* 25: 1520-1522.
- Li, X., T. H. Ko, et al. (2001). "Intraluminal fiber-optic Doppler imaging catheter for structural and functional optical coherence tomography." *Optics Letters* 26: 1906-1908.
- Liddington, M. I. and P. G. Shakespeare (1996). "Timing of the thermographic assessment of burns." *Burns* 22(1): 26-8.
- Lindmo, T., D. J. Smithies, et al. (1998). "Accuracy and noise in optical Doppler tomography studied by Monte Carlo simulation." *Physics in Medicine and Biology* 43(10): 3045-3064.
- Liu, J., X. Chen, et al. (1999). "New thermal wave aspects on burn evaluation of skin subjected to instantaneous heating." *IEEE Transactions on Biomedical Engineering* 46(4): 420-8.
- Luke, D. G., R. McBride, et al. (1995). "Polarization mode dispersion minimization in fiber-wound piezoelectric cylinders." *Optics Letters* 20(24): 2550-2552.
- MacNeill, B. D., I. K. Jong, et al. (2004). "Focal and multi-focal plaque distributions in patients with macrophage acute and stable presentations of coronary artery disease." *Journal of the American College of Cardiology* 44(5): 972-979.
- Mahgerefteh, D. and C. R. Menyuk (1999). "Effect of first-order PMD compensation on the statistics of pulse broadening in a fiber with randomly varying birefringence." *Ieee Photonics Technology Letters* 11(3): 340-342.
- Maitland, D. J. and J. T. Walsh, Jr. (1997). "Quantitative measurements of linear birefringence during heating of native collagen." *Lasers in Surgery & Medicine* 20 (3): 310-8.
- Majaron, B., S. M. Srinivas, et al. (2000). "Deep coagulation of dermal collagen with repetitive Er : YAG laser irradiation." *Lasers in Surgery and Medicine* 26(2): 215-222.
- Mansuripur, M. (1991). "Effects of High-Numerical-Aperture Focusing on the State of Polarization in Optical and Magneto-optic Data-Storage Systems." *Applied Optics* 30(22): 3154-3162.
- Marshall, G. W., S. J. Marshall, et al. (1997). "The dentin substrate: structure and properties related to bonding." *Journal of Dentistry* 25(6): 441-458.
- Martin, P. (1997). "Wound healing—Aiming for perfect skin regeneration." *Science* 276 (5309): 75-81.
- Martinez, O. E. (1987). "3000 Times Grating Compressor with Positive Group-Velocity Dispersion—Application to Fiber Compensation in 1.3-1.6 Mu-M Region." *Ieee Journal of Quantum Electronics* 23(1): 59-64.
- Martinez, O. E., J. P. Gordon, et al. (1984). "Negative Group-Velocity Dispersion Using Refraction." *Journal of the Optical Society of America a-Optics Image Science and Vision* 1(10): 1003-1006.
- McKinney, J. D., M. A. Webster, et al. (2000). "Characterization and imaging in optically scattering media by use of laser speckle and a variable-coherence source." *Optics Letters* 25(1): 4-6.
- Miglior, S., M. Casula, et al. (2001). "Clinical ability of Heidelberg retinal tomograph examination to detect glaucomatous visual field changes." *Ophthalmology* 108 (9): 1621-7.
- Milner, T. E., D. M. Goodman, et al. (1996). "Imaging laser heated subsurface chromophores in biological materials: Determination of lateral physical dimensions." *Physics in Medicine and Biology* 41(1): 31-44.
- Milner, T. E., D. M. Goodman, et al. (1995). "Depth Profiling of Laser-Heated Chromophores in Biological Tissues by Pulsed Photothermal Radiometry." *Journal of the Optical Society of America a-Optics Image Science and Vision* 12 (7): 1479-1488.
- Milner, T. E., D. J. Smithies, et al. (1996). "Depth determination of chromophores in human skin by pulsed photothermal radiometry." *Applied Optics* 35(19): 3379-3385.
- Mishchenko, M. I. and J. W. Hovenier (1995). "Depolarization of Light Backscattered by Randomly Oriented Nonspherical Particles." *Optics Letters* 20(12): 1356-&.
- Mistlberger, A., J. M. Liebmann, et al. (1999). "Heidelberg retina tomography and optical coherence tomography in normal, ocular-hypertensive, and glaucomatous eyes." *Ophthalmology* 106(10): 2027-32.

(56)

References Cited

OTHER PUBLICATIONS

- Mitsui, T. (1999). "High-speed detection of ballistic photons propagating through suspensions using spectral interferometry." *Japanese Journal of Applied Physics Part 1—Regular Papers Short Notes & Review Papers* 38(5A): 2978-2982.
- Molteno, A. C., N. J. Bosma, et al. (1999). "Otago glaucoma surgery outcome study: long-term results of trabeculectomy—1976 to 1995." *Ophthalmology* 106(9): 1742-50.
- Morgner, U., W. Drexler, et al. (2000). "Spectroscopic optical coherence tomography." *Optics Letters* 25(2): 111-113.
- Morgner, U., F. X. Kartner, et al. (1999). "Sub-two-cycle pulses from a Kerr-lens mode-locked Ti : sapphire laser (vol. 24, p. 411, 1999)." *Optics Letters* 24(13): 920-920.
- Mourant, J. R., A. H. Hielscher, et al. (1998). "Evidence of intrinsic differences in the light scattering properties of tumorigenic and nontumorigenic cells." *Cancer Cytopathology* 84(6): 366-374.
- Muller, M., J. Squier, et al. (1998). "Dispersion pre-compensation of 15 femtosecond optical pulses for high-numerical-aperture objectives." *Journal of Microscopy—Oxford* 191: 141-150.
- Muscat, S., N. McKay, et al. (2002). "Repeatability and reproducibility of corneal thickness measurements by optical coherence tomography." *Investigative Ophthalmology & Visual Science* 43(6): 1791-5.
- Musch, D. C., P. R. Lichter, et al. (1999). "The Collaborative Initial Glaucoma Treatment Study. Study Design, Methods, and Baseline Characteristics of Enrolled Patients." *Ophthalmology* 106: 653-662.
- Neerken, S., Lucassen, G.W., Bisschop, M.A., Lenderink, E., Nuijs, T.A.M. (2004). "Characterization of age-related effects in human skin: A comparative study that applies confocal laser scanning microscopy and optical coherence tomography." *Journal of Biomedical Optics* 9(2): 274-281.
- Nelson, J. S., K. M. Kelly, et al. (2001). "Imaging blood flow in human port-wine stain in situ and in real time using optical Doppler tomography." *Archives of Dermatology* 137(6): 741-744.
- Newson, T. P., F. Farahi, et al. (1988). "Combined Interferometric and Polarimetric Fiber Optic Temperature Sensor with a Short Coherence Length Source." *Optics Communications* 68(3): 161-165.
- November, L. J. (1993). "Recovery of the Matrix Operators in the Similarity and Congruency Transformations—Applications in Polarimetry." *Journal of the Optical Society of America a—Optics Image Science and Vision* 10(4): 719-739.
- Oh, W. Y., S. H. Yun, et al. (2005). "Wide tuning range wavelength-swept laser with two semiconductor optical amplifiers." *Ieee Photonics Technology Letters* 17(3): 678-680.
- Oka, K. and T. Kato (1999). "Spectroscopic polarimetry with a channeled spectrum." *Optics Letters* 24(21): 1475-1477.
- Okugawa, T. and K. Rotate (1996). "Real-time optical image processing by synthesis of the coherence function using real-time holography." *Ieee Photonics Technology Letters* 8(2): 257-259.
- Oshima, M., R. Torii, et al. (2001). "Finite element simulation of blood flow in the cerebral artery." *Computer Methods in Applied Mechanics and Engineering* 191 (6-7): 661-671.
- Pan, Y. T., H. K. Xie, et al. (2001). "Endoscopic optical coherence tomography based on a microelectromechanical mirror." *Optics Letters* 26(24): 1966-1968.
- Parisi, V., G. Manni, et al. (2001). "Correlation between optical coherence tomography, pattern electroretinogram, and visual evoked potentials in open-angle glaucoma patients." *Ophthalmology* 108(5): 905-12.
- Park, B. H., M. C. Pierce, et al. (2005). "Real-time fiber-based multifunctional spectral-domain optical coherence tomography at 1.3 μm ." *Optics Express* 13(11): 3931-3944.
- Park, D. H., J. W. Hwang, et al. (1998). "Use of laser Doppler flowmetry for estimation of the depth of burns." *Plastic and Reconstructive Surgery* 101(6): 1516-1523.
- Pendry, J. B., A. J. Holden, et al. (1999). "Magnetism from conductors and enhanced nonlinear phenomena." *Ieee Transactions on Microwave Theory and Techniques* 47(11): 2075-2084.
- Penninckx, D. and V. Morenas (1999). "Jones matrix of polarization mode dispersion." *Optics Letters* 24(13): 875-877.
- Pierce, M. C., M. Shishkov, et al. (2005). "Effects of sample arm motion in endoscopic polarization-sensitive optical coherence tomography." *Optics Express* 13(15): 5739-5749.
- Pircher, M., E. Gotzinger, et al. (2003). "Measurement and imaging of water concentration in human cornea with differential absorption optical coherence tomography." *Optics Express* 11(18): 2190-2197.
- Pircher, M., E. Gotzinger, et al. (2003). "Speckle reduction in optical coherence tomography by frequency compounding." *Journal of Biomedical Optics* 8(3): 565-569.
- Podoleanu, A. G., G. M. Dobre, et al. (1998). "En-face coherence imaging using galvanometer scanner modulation." *Optics Letters* 23(3): 147-149.
- Podoleanu, A. G. and D. A. Jackson (1999). "Noise analysis of a combined optical coherence tomograph and a confocal scanning ophthalmoscope." *Applied Optics* 38(10): 2116-2127.
- Podoleanu, A. G., J. A. Rogers, et al. (2000). "Three dimensional OCT images from retina and skin." *Optics Express* 7(9): 292-298.
- Podoleanu, A. G., M. Seeger, et al. (1998). "Transversal and longitudinal images from the retina of the living eye using low coherence reflectometry." *Journal of Biomedical Optics* 3(1): 12-20.
- Poole, C. D. (1988). "Statistical Treatment of Polarization Dispersion in Single-Mode Fiber." *Optics Letters* 13(8): 687-689.
- Povazay, B., K. Bizheva, et al. (2002). "Submicrometer axial resolution optical coherence tomography." *Optics Letters* 27(20): 1800-1802.
- Qi, B., A. P. Himmer, et al. (2004). "Dynamic focus control in high-speed optical coherence tomography based on a microelectromechanical mirror." *Optics Communications* 232(1-6): 123-128.
- Radhakrishnan, S., A. M. Rollins, et al. (2001). "Real-time optical coherence tomography of the anterior segment at 1310 nm." *Archives of Ophthalmology* 119(8): 1179-1185.
- Rogers, A. J. (1981). "Polarization-Optical Time Domain Reflectometry—a Technique for the Measurement of Field Distributions." *Applied Optics* 20(6): 1060-1074.
- Rollins, A. M. and J. A. Izatt (1999). "Optimal interferometer designs for optical coherence tomography." *Optics Letters* 24(21): 1484-1486.
- Rollins, A. M., R. Ung-arnyawee, et al. (1999). "Real-time in vivo imaging of human gastrointestinal ultrastructure by use of endoscopic optical coherence tomography with a novel efficient interferometer design." *Optics Letters* 24(19): 1358-1360.
- Rollins, A. M., S. Yazdanfar, et al. (2002). "Real-time in vivo colors Doppler optical coherence tomography." *Journal of Biomedical Optics* 7(1): 123-129.
- Rollins, A. M., S. Yazdanfar, et al. (2000). "Imaging of human retinal hemodynamics using color Doppler optical coherence tomography." *Investigative Ophthalmology & Visual Science* 41(4): S548-S548.
- Sandoz, P. (1997). "Wavelet transform as a processing tool in white-light interferometry." *Optics Letters* 22(14): 1065-1067.
- Sankaran, V., M. J. Everett, et al. (1999). "Comparison of polarized-light propagation in biological tissue and phantoms." *Optics Letters* 24(15): 1044-1046.
- Sankaran, V., J. T. Walsh, et al. (2000). "Polarized light propagation through tissue phanto, ehms containing densely packed scatterers." *Optics Letters* 25(4): 239-241.
- Sarunic, M. V., M. A. Choma, et al. (2005). "Instantaneous complex conjugate resolved spectral domain and swept-source OCT using 3x3 fiber couplers." *Optics Express* 13(3): 957-967.
- Sathyam, U. S., B. W. Colston, et al. (1999). "Evaluation of optical coherence quantitation of analytes in turbid media by use of two wavelengths." *Applied Optics* 38(10): 2097-2104.
- Schmitt, J. M. (1997). "Array detection for speckle reduction in optical coherence microscopy." *Physics in Medicine and Biology* 42(7): 1427-1439.
- Schmitt, J. M. (1999). "Optical coherence tomography (OCT): A review." *Ieee Journal of Selected Topics in Quantum Electronics* 5(4): 1205-1215.
- Schmitt, J. M. and A. Knüttel (1997). "Model of optical coherence tomography of heterogeneous tissue." *Journal of the Optical Society of America a—Optics Image Science and Vision* 14(6): 1231-1242.

(56)

References Cited

OTHER PUBLICATIONS

- Schmitt, J. M., S. L. Lee, et al. (1997). "An optical coherence microscope with enhanced resolving power in thick tissue." *Optics Communications* 142(4-6): 203-207.
- Schmitt, J. M., S. H. Xiang, et al. (1998). "Differential absorption imaging with optical coherence tomography." *Journal of the Optical Society of America a-Optics Image Science and Vision* 15(9): 2288-2296.
- Schmitt, J. M., S. H. Xiang, et al. (1999). "Speckle in optical coherence tomography." *Journal of Biomedical Optics* 4(1): 95-105.
- Schmitt, J. M., M. J. Yadlowsky, et al. (1995). "Subsurface Imaging of Living Skin with Optical Coherence Microscopy." *Dermatology* 191(2): 93-98.
- Shi, H., J. Finlay, et al. (1997). "Multiwavelength 10-GHz picosecond pulse generation from a single-stripe semiconductor diode laser." *Ieee Photonics Technology Letters* 9(11): 1439-1441.
- Shi, H., I. Nitta, et al. (1999). "Demonstration of phase correlation in multiwavelength mode-locked semiconductor diode lasers." *Optics Letters* 24(4): 238-240.
- Simon, R. (1982). "The Connection between Mueller and Jones Matrices of Polarization Optics." *Optics Communications* 42(5): 293-297.
- Smith, P. J. M., E.M.; Taylor, C.M.; Selviah, D.R.; Day, S.E.; Commander, L.G. "Variable-Focus Microlenses as a Potential Technology for Endoscopy."
- Smithies, D. J., T. Lindmo, et al. (1998). "Signal attenuation and localization in optical coherence tomography studied by Monte Carlo simulation." *Physics in Medicine and Biology* 43(10): 3025-3044.
- Sorin, W. V. and D. F. Gray (1992). "Simultaneous Thickness and Group Index Measurement Using Optical Low-Coherence Reflectometry." *Ieee Photonics Technology Letters* 4(1): 105-107.
- Sticker, M., C. K. Hitzenberger, et al. (2001). "Quantitative differential phase measurement and imaging in transparent and turbid media by optical coherence tomography." *Optics Letters* 26(8): 518-520.
- Sticker, M., M. Pircher, et al. (2002). "En face imaging of single cell layers by differential phase-contrast optical coherence microscopy." *Optics Letters* 27(13): 1126-1128.
- Stoller, P., B. M. Kim, et al. (2002). "Polarization-dependent optical second-harmonic imaging of a rat-tail tendon." *Journal of Biomedical Optics* 7(2): 205-214.
- Sun, C. S. (2003). "Multiplexing of fiber-optic acoustic sensors in a Michelson interferometer configuration." *Optics Letters* 28(12): 1001-1003.
- Swanson, E. A., J. A. Izatt, et al. (1993). "In-Vivo Retinal Imaging by Optical Coherence Tomography." *Optics Letters* 18(21): 1864-1866.
- Takada, K., A. Himeno, et al. (1991). "Phase-Noise and Shot-Noise Limited Operations of Low Coherence Optical-Time Domain Reflectometry." *Applied Physics Letters* 59(20): 2483-2485.
- Takenaka, H. (1973). "Unified Formalism for Polarization Optics by Using Group-Theory I (Theory)." *Japanese Journal of Applied Physics* 12(2): 226-231.
- Tanno, N., T. Ichimura, et al. (1994). "Optical Multimode Frequency-Domain Reflectometer." *Optics Letters* 19(8): 587-589.
- Tan-no, N., T. Ichimura, et al. (1994). "Optical Multimode Frequency-Domain Reflectometer." *Optics Letters* 19(8): 587-589.
- Targowski, P., M. Wojtkowski, et al. (2004). "Complex spectral OCT in human eye imaging in vivo." *Optics Communications* 229(1-6): 79-84.
- Tearney, G. J., S. A. Boppart, et al. (1996). "Scanning single-mode fiber optic catheter-endoscope for optical coherence tomography (vol. 21, p. 543, 1996)." *Optics Letters* 21(12): 912-912.
- Tearney, G. J., B. E. Bouma, et al. (1996). "Rapid acquisition of in vivo biological images by use of optical coherence tomography." *Optics Letters* 21(17): 1408-1410.
- Tearney, G. J., B. E. Bouma, et al. (1997). "In vivo endoscopic optical biopsy with optical coherence tomography." *Science* 276(5321): 2037-2039.
- Tearney, G. J., M. E. Brezinski, et al. (1996). "Catheter-based optical imaging of a human coronary artery." *Circulation* 94(11): 3013-3013.
- Tearney, G. J., M. E. Brezinski, et al. (1997). "In vivo endoscopic optical biopsy with optical coherence tomography." *Science* 276(5321): 2037-9.
- Tearney, G. J., M. E. Brezinski, et al. (1997). "Optical biopsy in human gastrointestinal tissue using optical coherence tomography." *American Journal of Gastroenterology* 92(10): 1800-1804.
- Tearney, G. J., M. E. Brezinski, et al. (1995). "Determination of the refractive index of highly scattering human tissue by optical coherence tomography." *Optics Letters* 20(21): 2258-2260.
- Tearney, G. J., I. K. Jang, et al. (2000). "Porcine coronary imaging in vivo by optical coherence tomography." *Acta Cardiologica* 55(4): 233-237.
- Tearney, G. J., R. H. Webb, et al. (1998). "Spectrally encoded confocal microscopy." *Optics Letters* 23(15): 1152-1154.
- Tearney, G. J., H. Yabushita, et al. (2003). "Quantification of macrophage content in atherosclerotic plaques by optical coherence tomography." *Circulation* 107(1): 113-119.
- Tower, T. T. and R. T. Tranquillo (2001). "Alignment maps of tissues: I. Microscopic elliptical polarimetry." *Biophysical Journal* 81(5): 2954-2963.
- Tower, T. T. and R. T. Tranquillo (2001). "Alignment maps of tissues: II. Fast harmonic analysis for imaging." *Biophysical Journal* 81(5): 2964-2971.
- Troy, T. L. and S. N. Thennadil (2001). "Optical properties of human skin in the near infrared wavelength range of 1000 to 2200 nm." *Journal of Biomedical Optics* 6 (2): 167-176.
- Vabre, L., A. Dubois, et al. (2002). "Thermal-light full-field optical coherence tomography." *Optics Letters* 27(7): 530-532.
- Vakhtin, A. B., D. J. Kane, et al. (2003). "Common-path interferometer for frequency-domain optical coherence tomography." *Applied Optics* 42(34): 6953-6958.
- Vakhtin, A. B., K. A. Peterson, et al. (2003). "Differential spectral interferometry: an imaging technique for biomedical applications." *Optics Letters* 28(15): 1332-1334.
- Vakoc, B. J., S. H. Yun, et al. (2005). "Phase-resolved optical frequency domain imaging." *Optics Express* 13(14): 5483-5493.
- van Leeuwen, T. G., M. D. Kulkarni, et al. (1999). "High-flow-velocity and shear-rate imaging by use of color Doppler optical coherence tomography." *Optics Letters* 24(22): 1584-1586.
- Vansteenkiste, N., P. Vignolo, et al. (1993). "Optical Reversibility Theorems for Polarization—Application to Remote-Control of Polarization." *Journal of the Optical Society of America a-Optics Image Science and Vision* 10(10): 2240-2245.
- Vargas, O., E. K. Chan, et al. (1999). "Use of an agent to reduce scattering in skin." *Lasers in Surgery and Medicine* 24(2): 133-141.
- Wang, R. K. (1999). "Resolution improved optical coherence-gated tomography for imaging through biological tissues." *Journal of Modern Optics* 46(13): 1905-1912.
- Wang, X. J., T. E. Milner, et al. (1997). "Measurement of fluid-flow-velocity profile in turbid media by the use of optical Doppler tomography." *Applied Optics* 36(1): 144-149.
- Wang, X. J., T. E. Milner, et al. (1995). "Characterization of Fluid-Flow Velocity by Optical Doppler Tomography." *Optics Letters* 20(11): 1337-1339.
- Wang, Y. M., J. S. Nelson, et al. (2003). "Optimal wavelength for ultrahigh-resolution optical coherence tomography." *Optics Express* 11(12): 1411-1417.
- Wang, Y. M., Y. H. Zhao, et al. (2003). "Ultrahigh-resolution optical coherence tomography by broadband continuum generation from a photonic crystal fiber." *Optics Letters* 28(3): 182-184.
- Watkins, L. R., S. M. Tan, et al. (1999). "Determination of interferometer phase distributions by use of wavelets." *Optics Letters* 24(13): 905-907.
- Wetzel, J. (2001). "Optical coherence tomography in dermatology: a review." *Skin Research and Technology* 7(1): 1-9.
- Wentworth, R. H. (1989). "Theoretical Noise Performance of Coherence-Multiplexed Interferometric Sensors." *Journal of Lightwave Technology* 7(6): 941-956.
- Westphal, V., A. M. Rollins, et al. (2002). "Correction of geometric and refractive image distortions in optical coherence tomography applying Fermat's principle." *Optics Express* 10(9): 397-404.

(56)

References Cited

OTHER PUBLICATIONS

- Westphal, V., S. Yazdanfar, et al. (2002). "Real-time, high velocity-resolution color Doppler optical coherence tomography." *Optics Letters* 27(1): 34-36.
- Williams, P. A. (1999). "Rotating-wave-plate Stokes polarimeter for differential group delay measurements of polarization-mode dispersion." *Applied Optics* 38(31): 6508-6515.
- Wojtkowski, M., T. Bajraszewski, et al. (2003). "Real-time in vivo imaging by high-speed spectral optical coherence tomography." *Optics Letters* 28(19): 1745-1747.
- Wojtkowski, M., A. Kowalczyk, et al. "Full range complex spectral optical coherence tomography technique in eye imaging." (2002). *Optics Letters* 27(16): 1415-1417.
- Wojtkowski, M., R. Leitgeb, et al. (2002). "In vivo human retinal imaging by Fourier domain optical coherence tomography." *Journal of Biomedical Optics* 7(3): 457-463.
- Wojtkowski, M., R. Leitgeb, et al. (2002). "Fourier domain OCT imaging of the human eye in vivo." *Proc. SPIE* 4619: 230-236.
- Wojtkowski, M., V. J. Srinivasan, et al. (2004). "Ultrahigh-resolution, high-speed, Fourier domain optical coherence tomography and methods for dispersion compensation." *Optics Express* 12(11): 2404-2422.
- Wong, B. J. F., Y. H. Zhao, et al. (2004). "Imaging the internal structure of the rat cochlea using optical coherence tomography at 0.827 μm and 1.3 μm ." *Otolaryngology-Head and Neck Surgery* 130(3): 334-338.
- Yabushita, H. B., B.E.; Houser, S.L.; Aretz, H.T.; Jang, I.; Schlendorf, K.H.; Kauffman, C.R.; Shishkov, M.; Halpern, E.F.; Tearney, G.J. "Measurement of Thin Fibrous Caps in Atherosclerotic Plaques by Optical Coherence Tomography."
- Yang, C., A. Wax, et al. (2001). "Phase-dispersion optical tomography." *Optics Letters* 26(10): 686-688.
- Yang, C., A. Wax, et al. (2001). "Phase-referenced interferometer with subwavelength and subhertz sensitivity applied to the study of cell membrane dynamics." *Optics Letters* 26(16): 1271-1273.
- Yang, C. H., A. Wax, et al. (2001). "Phase-dispersion optical tomography." *Optics Letters* 26(10): 686-688.
- Yang, C. H., A. Wax, et al. (2000). "Interferometric phase-dispersion microscopy." *Optics Letters* 25(20): 1526-1528.
- Yang, V. X. D., M. L. Gordon, et al. (2002). "Improved phase-resolved optical Doppler tomography using the Kasai velocity estimator and histogram segmentation." *Optics Communications* 208(4-6): 209-214.
- Yang, V. X. D., M. L. Gordon, et al. (2003). "High speed, wide velocity dynamic range Doppler optical coherence tomography (Part I): System design, signal processing, and performance." *Optics Express* 11(7): 794-809.
- Yang, V. X. D., M. L. Gordon, et al. (2003). "High speed, wide velocity dynamic range Doppler optical coherence tomography (Part II): Imaging in vivo cardiac dynamics of *Xenopus laevis*." *Optics Express* 11(14): 1650-1658.
- Yang, V. X. D., M. L. Gordon, et al. (2003). "High speed, wide velocity dynamic range Doppler optical coherence tomography (Part III): in vivo endoscopic imaging of blood flow in the rat and human gastrointestinal tracts." *Optics Express* 11(19): 2416-2424.
- Yang, V. X. D., B. Qi, et al. (2003). "In vivo feasibility of endoscopic catheter-based Doppler optical coherence tomography." *Gastroenterology* 124(4): A49-A50.
- Yao, G. and L. H. V. Wang (2000). "Theoretical and experimental studies of ultrasound-modulated optical tomography in biological tissue." *Applied Optics* 39(4): 659-664.
- Yazdanfar, S. and J. A. Izatt (2002). "Self-referenced Doppler optical coherence tomography." *Optics Letters* 27(23): 2085-2087.
- Yazdanfar, S., M. D. Kulkarni, et al. (1997). "High resolution imaging of in vivo cardiac dynamics using color Doppler optical coherence tomography." *Optics Express* 1 (13) : 424-431.
- Yazdanfar, S., A. M. Rollins, et al. (2000). "Imaging and velocimetry of the human retinal circulation with color Doppler optical coherence tomography." *Optics Letters* 25(19): 1448-1450.
- Yazdanfar, S., A. M. Rollins, et al. (2000). "Noninvasive imaging and velocimetry of human retinal blood flow using color Doppler optical coherence tomography." *Investigative Ophthalmology & Visual Science* 41(4): S548-S548.
- Yazdanfar, S., A. M. Rollins, et al. (2003). "In vivo imaging of human retinal flow dynamics by color Doppler optical coherence tomography." *Archives of Ophthalmology* 121(2): 235-239.
- Yazdanfar, S., C. H. Yang, et al. (2005). "Frequency estimation precision in Doppler optical coherence tomography using the Cramer-Rao lower bound." *Optics Express* 13(2): 410-416.
- Yun, S. H., C. Boudoux, et al. (2004). "Extended-cavity semiconductor wavelength-swept laser for biomedical imaging." *Ieee Photonics Technology Letters* 16(1): 293-295.
- Yun, S. H., C. Boudoux, et al. (2003). "High-speed wavelength-swept semiconductor laser with a polygon-scanner-based wavelength filter." *Optics Letters* 28(20): 1981-1983.
- Yun, S. H., G. J. Tearney, et al. (2004). "Pulsed-source and swept-source spectral-domain optical coherence tomography with reduced motion artifacts." *Optics Express* 12(23): 5614-5624.
- Yun, S. H., G. J. Tearney, et al. (2004). "Removing the depth-degeneracy in optical frequency domain imaging with frequency shifting." *Optics Express* 12(20): 4822-4828.
- Yun, S. H., G. J. Tearney, et al. (2004). "Motion artifacts in optical coherence tomography with frequency-domain ranging." *Optics Express* 12(13): 2977-2998.
- Zhang, J., J. S. Nelson, et al. (2005). "Removal of a mirror image and enhancement of the signal-to-noise ratio in Fourier-domain optical coherence tomography using an electro-optic phase modulator." *Optics Letters* 30(2): 147-149.
- Zhang, Y., M. Sato, et al. (2001). "Numerical investigations of optimal synthesis of several low coherence sources for resolution improvement." *Optics Communications* 192(3-6): 183-192.
- Zhang, Y., M. Sato, et al. (2001). "Resolution improvement in optical coherence tomography by optimal synthesis of light-emitting diodes." *Optics Letters* 26(4): 205-207.
- Zhao, Y., Z. Chen, et al. (2002). "Real-time phase-resolved functional optical coherence tomography by use of optical Hilbert transformation." *Optics Letters* 27(2): 98-100.
- Zhao, Y. H., Z. P. Chen, et al. (2000). "Doppler standard deviation imaging for clinical monitoring of in vivo human skin blood flow." *Optics Letters* 25(18): 1358-1360.
- Zhao, Y. H., Z. P. Chen, et al. (2000). "Phase-resolved optical coherence tomography and optical Doppler tomography for imaging blood flow in human skin with fast scanning speed and high velocity sensitivity." *Optics Letters* 25(2): 114-116.
- Zhou, D., P. R. Prucnal, et al. (1998). "A widely tunable narrow linewidth semiconductor fiber ring laser." *IEEE Photonics Technology Letters* 10(6): 781-783.
- Zuluaga, A. F. and R. Richards-Kortum (1999). "Spatially resolved spectral interferometry for determination of subsurface structure." *Optics Letters* 24(8): 519-521.
- Zvyagin, A. V., J. B. FitzGerald, et al. (2000). "Real-time detection technique for Doppler optical coherence tomography." *Optics Letters* 25(22): 1645-1647.
- Marc Nikles et al., "Brillouin gain spectrum characterization in single-mode optical fibers", *Journal of Lightwave Technology* 1997, 15 (10): 1842-1851.
- Tsuyoshi Sonehara et al., "Forced Brillouin Spectroscopy Using Frequency-Tunable Continuous-Wave Lasers", *Physical Review Letters* 1995, 75 (23): 4234-4237.
- Hajime Tanaka et al., "New Method of Superheterodyne Light Beating Spectroscopy for Brillouin-Scattering Using Frequency-Tunable Lasers", *Physical Review Letters* 1995, 74 (9): 1609-1612.
- Webb RH et al. "Confocal Scanning Laser Ophthalmoscope", *Applied Optics* 1987, 26 (8): 1492-1499.
- Andreas Zumbusch et al. "Three-dimensional vibrational imaging by coherent anti-Stokes Raman scattering", *Physical Review Letters* 1999, 82 (20): 4142-4145.
- Katrin Kneipp et al., "Single molecule detection using surface-enhanced Raman scattering (SERS)", *Physical Review Letters* 1997, 78 (9): 1667-1670.
- K.J. Koski et al., "Brillouin imaging" *Applied Physics Letters* 87, 2005.

(56)

References Cited

OTHER PUBLICATIONS

- Boas et al., "Diffusing temporal light correlation for burn diagnosis", *SPIE*, 1999, 2979:468-477.
- David J. Briers, "Speckle fluctuations and biomedical optics: implications and applications", *Optical Engineering*, 1993, 32(2):277-283.
- Clark et al., "Tracking Speckle Patterns with Optical Correlation", *SPIE*, 1992, 1772:77-87.
- Clark et al., "Tracking Speckle Patterns with Optical Correlation", *SPIE*, 1992, 1772:77-87.
- Facchini et al., "An endoscopic system for DSPI", *Optik*, 1993, 95(1):27-30.
- Hrabovsky, M., "Theory of speckle displacement and decorrelation: application in mechanics", *SPIE*, 1998, 3479:345-354.
- Sean J. Kirkpatrick et al., "Micromechanical behavior of cortical bone as inferred from laser speckle data", *Journal of Biomedical Materials Research*, 1998, 39(3):373-379.
- Sean J. Kirkpatrick et al., "Laser speckle microstrain measurements in vascular tissue", *SPIE*, 1999, 3598:121-129.
- Loree et al., "Mechanical Properties of Model Atherosclerotic Lesion Lipid Pools", *Arteriosclerosis and Thrombosis*, 1994, 14(2):230-234.
- Podbielska, H. "Interferometric Methods and Biomedical Research", *SPIE*, 1999, 2732:134-141.
- Richards-Kortum et al., "Spectral diagnosis of atherosclerosis using an optical fiber laser catheter", *American Heart Journal*, 1989, 118(2):381-391.
- Ruth, B. "blood flow determination by the laser speckle method", *Int J Microcirc: Clin Exp*, 1990, 9:21-45.
- Shapo et al., "Intravascular strain imaging: Experiments on an Inhomogeneous Phantom", *IEEE Ultrasonics Symposium* 1996, 2:1177-1180.
- Shapo et al., "Ultrasonic displacement and strain imaging of coronary arteries with a catheter array", *IEEE Ultrasonics Symposium* 1995, 2:1511-1514.
- Thompson et al., "Imaging in scattering media by use of laser speckle", *Opt. Soc. Am. A.*, 1997, 14(9):2269-2277.
- Thompson et al., "Diffusive media characterization with laser speckle", *Applied Optics*, 1997, 36(16):3726-3734.
- Tuchin, Valery V., "Coherent Optical Techniques for the Analysis of Tissue Structure and Dynamics," *Journal of Biomedical Optics*, 1999, 4(1):106-124.
- M. Wussling et al., "Laser diffraction and speckling studies in skeletal and heart muscle", *Biomed, Biochim, Acta*, 1986, 45(1/2): S 23-S 27.
- T. Yoshimura et al., "Statistical properties of dynamic speckles", *J. Opt. Soc. Am. A.* 1986, 3(7):1032-1054.
- Zimnyakov et al., "Spatial speckle correlometry in applications to tissue structure monitoring", *Applied Optics* 1997, 36(22): 5594-5607.
- Zimnyakov et al., "A study of statistical properties of partially developed speckle fields as applied to the diagnosis of structural changes in human skin", *Optics and Spectroscopy*, 1994, 76(5): 747-753.
- Zimnyakov et al., "Speckle patterns polarization analysis as an approach to turbid tissue structure monitoring", *SPIE* 1999, 2981:172-180.
- Ramasamy Manoharan et al., "Biochemical analysis and mapping of atherosclerotic human artery using FT-IR microspectroscopy", *Atherosclerosis*, May 1993, 181-1930.
- N.V. Salunke et al., "Biomechanics of Atherosclerotic Plaque" *Critical Reviews™ in Biomedical Engineering* 1997, 25(3):243-285.
- D. Fu et al., "Non-invasive quantitative reconstruction of tissue elasticity using an iterative forward approach", *Phys. Med. Biol.* 2000 (45): 1495-1509.
- S.B. Adams Jr. et al., "The use of polarization sensitive optical coherence tomography and elastography to assess connective tissue", *Optical Soc. of American Washington* 2002, p. 3.
- International Search Report for International Patent application No. PCT/US2005/039740.
- International Written Opinion for International Patent application No. PCT/US2005/039740.
- International Search Report for International Patent application No. PCT/US2005/030294.
- International Written Opinion for International Patent application No. PCT/US2005/043951.
- International Search Report for International Patent application No. PCT/US2005/043951.
- Erdelyi et al. "Generation of diffraction-free beams for applications in optical microlithography", *J. Vac. Sci. Technol. B* 15 (12), Mar./Apr. 1997, pp. 287-292.
- International Search Report for International Patent application No. PCT/US2005/023664.
- International Written Opinion for International Patent application No. PCT/US2005/023664.
- Tearney et al., "Spectrally encoded miniature endoscopy" *Optical Society of America; Optical Letters* vol. 27, No. 6, Mar. 15, 2002; pp. 412-414.
- Yelin et al., "Double-clad Fiber for Endoscopy" *Optical Society of America; Optical Letters* vol. 29, No. 20, Oct. 16, 2005; pp. 2408-2410.
- International Search Report for International Patent application No. PCT/US2001/049704.
- International Search Report for International Patent application No. PCT/US2004/039454.
- International Written Opinion for International Patent application No. PCT/US2004/039454.
- PCT International Preliminary Report on Patentability for International Application No. PCT/US2004/038404 dated Jun. 2, 2006.
- Notice of Reasons for Rejection and English translation for Japanese Patent Application No. 2002-538830.
- Office Action dated Aug. 24, 2006 for U.S. Appl. No. 10/137,749.
- Barry Cense et al., "Spectral-domain polarization-sensitive optical coherence tomography at 850nm", *Coherence Domain Optical Methods and Optical Coherence Tomography in Biomedicine IX*, 2005, pp. 159-162.
- A. Ymeti et al., "Integration of microfluidics with a four-channel integrated optical Young interferometer immunosensor", *Biosensors and Bioelectronics*, Elsevier Science Publishers, 2005, pp. 1417-1421.
- PCT International Search Report for Application No. PCT/US2006/018865 filed May 5, 2006.
- International Written Opinion for International Patent application No. PCT/US2006/018865 filed May 5, 2006.
- John M. Ponerros, "Diagnosis of Barrett's esophagus using optical coherence tomography", *Gastrointestinal Endoscopy clinics of North America*, 14 (2004) pp. 573-588.
- P.F. Escobar et al., "Diagnostic efficacy of optical coherence tomography in the management of preinvasive and invasive cancer of uterine cervix and vulva", *Int. Journal of Gynecological Cancer* 2004, 14, pp. 470-474.
- Ko T et al., "Ultrahigh resolution in vivo versus ex vivo OCT imaging and tissue preservation", *Conference on Lasers and electro-optics*, 2001, pp. 252-253.
- Paul M. Ripley et al., "A comparison of Artificial Intelligence techniques for spectral classification in the diagnosis of human pathologies based upon optical biopsy", *Journal of Optical Society of America*, 2000, pp. 217-219.
- Wolfgang Drexler et al., "Ultrahigh-resolution optical coherence tomography", *Journal of Biomedical Optics Spie USA*, 2004, pp. 47-74.
- PCT International Search Report for Application No. PCT/US2006/016677 filed Apr. 28, 2006.
- International Written Opinion for International Patent application No. PCT/US2006/016677 filed Apr. 28, 2006.
- Office Action dated Nov. 13, 2006 for U.S. Appl. No. 10/501,268.
- Office Action dated Nov. 20, 2006 for U.S. Appl. No. 09/709,162.
- PCT International Search Report and Written Opinion for Application No. PCT/US2004/023585 filed Jul. 23, 2004.
- Office Action dated Dec. 6, 2006 for U.S. Appl. No. 10/997,789.
- Elliott, K. H. "The use of commercial CCD cameras as linear detectors in the physics undergraduate teaching laboratory", *European Journal of Physics* 19, 1998, pp. 107-117.

(56)

References Cited

OTHER PUBLICATIONS

- Lauer, V. "New approach to optical diffraction tomography yielding a vector equation of diffraction tomography and a novel tomographic microscope", *Journal of Microscopy* vol. 205, Issue 2, 2002, pp. 165-176.
- Yu, P. et al. "Imaging of tumor necroses using full-frame optical coherence imaging", *Proceedings of SPIE* vol. 4956, 2003, pp. 34-41.
- Zhao, Y. et al. "Three-dimensional reconstruction of in vivo blood vessels in human skin using phase-resolved optical Doppler tomography", *IEEE Journal of Selected Topics in Quantum Electronics* 7.6 (2001): 931-935.
- Office Action dated Dec. 18, 2006 for U.S. Appl. No. 10/501,276.
- R. Haggitt et al., "Barrett's Esophagus Correlation Between Mucin Histochemistry, Flow Cytometry, and Histological Diagnosis for Predicting Increased Cancer Risk," Apr. 1988, *American Journal of Pathology*, vol. 131, No. 1, pp. 53-61.
- R.H. Hardwick et al., (1995) "c-erbB-2 Overexpression in the Dysplasia/Carcinoma Sequence of Barrett's Oesophagus," *Journal of Clinical Pathology*, vol. 48, No. 2, pp. 129-132.
- W. Polkowski et al, (1998) "Clinical Decision making in Barrett's Oesophagus can be supported by Computerized Immunoquantitation and Morphometry of Features Associated with Proliferation and Differentiation," *Journal of pathology*, vol. 184, pp. 161-168.
- J.R. Turner et al., MN Antigen Expression in Normal Preneoplastic, and Neoplastic Esophagus: A Clinicopathological Study of a New Cancer-Associated Biomarker, Jun. 1997, *Human Pathology*, vol. 28, No. 6, pp. 740-744.
- D.J. Bowery et al., (1999) "Patterns of Gastritis in Patients with Gastro-Oesophageal Reflux Disease," *Gut*, vol. 45, pp. 798-803.
- O'Reich et al., (2000) "Expression of Oestrogen and Progesterone Receptors in Low-Grade Endometrial Stromal Sarcomas," *British Journal of Cancer*, vol. 82, No. 5, pp. 1030-1034.
- M.I. Canto et al., (1999) "Vital Staining and Barrett's Esophagus," *Gastrointestinal Endoscopy*, vol. 49, No. 3, Part 2, pp. S12-S16.
- S. Jackle et al., (2000) "In Vivo Endoscopic Optical Coherence Tomography of the Human Gastrointestinal Tract-Toward Optical Biopsy," *Endoscopy*, vol. 32, No. 10, pp. 743-749.
- E. Montgomery et al., "Reproducibility of the Diagnosis of Dysplasia in Barrett Esophagus: A Reaffirmation," Apr. 2001, *Human Pathology*, vol. 32, No. 4, pp. 368-378.
- H. Geddert et al., "Expression of Cyclin B1 in the Metaplasia-Dysphasia-Carcinoma Sequence of Barrett Esophagus," Jan. 2002, *Cancer*, vol. 94, No. 1, pp. 212-218.
- P. Pfau et al., (2003) "Criteria for the Diagnosis of Dysphasia by Endoscopic Optical Coherence Tomography," *Gastrointestinal Endoscopy*, vol. 58, No. 2, pp. 196-2002.
- R. Kiesslich et al., (2004) "Confocal Laser Endoscopy for Diagnosing Intraepithelial Neoplasias and Colorectal Cancer in Vivo," *Gastroenterology*, vol. 127, No. 3, pp. 706-713.
- X. Qi et al., (2004) "Computer Aided Diagnosis of Dysphasia in Barrett's Esophagus Using Endoscopic Optical Coherence Tomography," *SPIE, Coherence Domain Optical Methods and Optical Coherence Tomography in Biomedicine VIII. Proc. of Conference on*, vol. 5316, pp. 33-40.
- Seltzer et al., (1991) "160 nm Continuous Tuning of a MQW Laser in an External Cavity Across the Entire 1.3 μ m Communications Window," *Electronics Letters*, vol. 27, pp. 95-96.
- Office Action dated Jan. 25, 2010 for U.S. Appl. No. 11/537,048.
- International Search Report dated Jan. 27, 2010 for PCT/US2009/050553.
- International Search Report dated Jan. 27, 2010 for PCT/US2009/047988.
- International Search Report dated Feb. 23, 2010 for U.S. Appl. No. 11/445,131.
- Office Action dated Mar. 18, 2010 of U.S. Appl. No. 11/844,454.
- Office Action dated Apr. 8, 2010 of U.S. Appl. No. 11/414,564.
- Japanese Office Action dated Apr. 13, 2010 for Japanese Patent application No. 2007-515029.
- International Search Report dated May 27, 2010 for PCT/US2009/063420.
- Office Action dated May 28, 2010 for U.S. Appl. No. 12/015,642.
- Office Action dated Jun. 2, 2010 for U.S. Appl. No. 12/112,205.
- Office Action dated Oct. 11, 2007 for U.S. Appl. No. 11/534,095.
- Office Action dated Oct. 9, 2007 for U.S. Appl. No. 09/709,162.
- Notice of Allowance dated Oct. 3, 2007 for U.S. Appl. No. 11/225,840.
- Siavash Yazdanfar et al., "In Vivo imaging in blood flow in human retinal vessels using color Doppler optical coherence tomography", *SPIE*, 1999 vol. 3598, pp. 177-184.
- Office Action dated Oct. 30, 2007 for U.S. Appl. No. 11/670,069.
- Tang C. L. et al., "Wide-band electro-optical tuning of semiconductor lasers", *Applied Physics Letters*, vol. 30, No. 2, Jan. 15, 1977, pp. 113-116.
- Tang C. L. et al., "Transient effects in wavelength-modulated dye lasers", *Applied Physics Letters*, vol. 26, No. 9, May 1, 1975, pp. 534-537.
- Telle M. John, et al., "Very rapid tuning of cw dye laser", *Applied Physics Letters*, vol. 26, No. 10, May 15, 1975, pp. 572-574.
- Telle M. John, et al., "New method for electro-optical tuning of tunable lasers", *Applied Physics Letters*, vol. 24, No. 2, Jan. 15, 1974, pp. 85-87.
- Schmitt M. Joseph et al. "OCT elastography: imaging microscopic deformation and strain of tissue", *Optics Express*, vol. 3, No. 6, Sep. 14, 1998, pp. 199-211.
- M. Gualini Muddassir et al., "Recent Advancements of Optical Interferometry Applied to Medicine", *IEEE Transactions on Medical Imaging*, vol. 23, No. 2, Feb. 2004, pp. 205-212.
- Maurice L. Roch et al. "Noninvasive Vascular Elastography: Theoretical Framework", *IEEE Transactions on Medical Imaging*, vol. 23, No. 2, Feb. 2004, pp. 164-180.
- Kirkpatrick J. Sean et al. "Optical Assessment of Tissue Mechanical Properties", *Proceedings of the SPIE—The International Society for Optical Engineering SPIE—vol. 4001, 2000, pp. 92-101.*
- Lisauskas B. Jennifer et al., "Investigation of Plaque Biomechanics from Intravascular Ultrasound Images using Finite Element Modeling", *Proceedings of the 19th International Conference—IEEE Oct. 30-Nov. 2, 1997, pp. 887-888.*
- Parker K. J. et al., "Techniques for Elastic Imaging: A Review", *IEEE Engineering in Medicine and Biology*, Nov./Dec. 1996, pp. 52-59.
- European Patent Office Search Report for Application No. 05791226.3.
- Dubois Arnaud et al., "Ultrahigh-resolution OCT using white-light interference microscopy", *Proceedings of SPIE*, 2003, vol. 4956, pp. 14-21.
- Office Action dated Jan. 3, 2008 for U.S. Appl. No. 10/997,789.
- Office Action dated Dec. 21, 2007 for U.S. Appl. No. 11/264,655.
- Office Action dated Dec. 18, 2007 for U.S. Appl. No. 11/288,994.
- Office Action dated Jan. 10, 2008 for U.S. Appl. No. 11/435,228.
- Office Action dated Jan. 10, 2008 for U.S. Appl. No. 11/410,937.
- Office Action dated Jan. 11, 2008 for U.S. Appl. No. 11/445,990.
- Office Action dated Feb. 4, 2008 for U.S. Appl. No. 10/861,179.
- PCT International Search Report and Written Opinion for Application No. PCT/US2007/061463 dated Jan. 23, 2008.
- PCT International Search Report and Written Opinion for Application No. PCT/US2007/061481 dated Mar. 17, 2008.
- PCT International Search Report and Written Opinion for Application No. PCT/US2007/078254 dated Mar. 28, 2008.
- Sadhwani, Ajay et al., "Determination of Teflon thickness with laser speckle I. Potential for burn depth diagnosis", *Optical Society of America*, 1996, vol. 35, No. 28, pp. 5727-5735.
- C.J. Stewart et al., "A comparison of two laser-based methods for determination of burn scar perfusion: Laser Doppler versus laser speckle imaging", *Elsevier Ltd.*, 2005, vol. 31, pp. 744-752.
- G. J. Tearney et al., "Atherosclerotic plaque characterization by spatial and temporal speckle pattern analysis", *CLEO 2001*, vol. 56, pp. 307-307.
- PCT International Search Report for Application No. PCT/US2007/068233 dated Feb. 21, 2008.
- PCT International Search Report for Application No. PCT/US2007/060787 dated Mar. 18, 2008.
- Statement under Article 19 and Reply to PCT Written Opinion for PCT International Application No. PCT/US2005/043951 dated Jun. 6, 2006.

(56)

References Cited

OTHER PUBLICATIONS

- PCT International Preliminary Report on Patentability for Application No. PCT/US2005/043951 dated Jun. 7, 2007.
- PCT International Search Report and Written Opinion for Application No. PCT/US2007/060670 dated Sep. 21, 2007.
- J. M. Schmitt et al., "Speckle in Optical Coherence Tomography: An Overview", SPIE vol. 3726, pp. 450-461.
- Hariri, Lida P. et al. "Endoscopic Optical Coherence Tomography and Laser-Induced Fluorescence Spectroscopy in a Murine Colon Cancer Model", *Laser in Surgery and Medicine*, vol. 38, 2006, pp. 305-313.
- PCT International Search Report and Written Opinion for Application No. PCT/US2006/031905 dated May 3, 2007.
- PCT International Search Report and Written Opinion for Application No. PCT/US2007/060481 dated May 23, 2007.
- PCT International Search Report and Written Opinion for Application No. PCT/US2007/060717 dated May 24, 2007.
- PCT International Search Report and Written Opinion for Application No. PCT/US2007/060319 dated Jun. 6, 2007.
- D. Yelin et al., "Three-dimensional imaging using spectral encoding heterodyne interferometry", *Optics Letters*, Jul. 15, 2005, vol. 30, No. 14, pp. 1794-1796.
- Akiba, Masahiro et al. "En-face optical coherence imaging for three-dimensional microscopy", SPIE, 2002, pp. 8-15.
- Office Action dated Aug. 10, 2007 for U.S. Appl. No. 10/997,789.
- Office Action dated Feb. 2, 2007 for U.S. Appl. No. 11/174,425.
- PCT International Search Report and Written Opinion for Application No. PCT/US2007/060657 dated Aug. 13, 2007.
- Lewis, Neil E. et al., "Applications of Fourier Transform Infrared Imaging Microscopy in Neurotoxicity", *Annals New York Academy of Sciences*, pp. 234-246.
- Joo, Chulmin et al., Spectral-domain optical coherence phase microscopy for quantitative phase-contrast imaging, *Optics Letters*, Aug. 15, 2005, vol. 30, No. 16, pp. 2131-2133.
- Guo, Bujin et al., "Laser-based mid-infrared reflectance imaging of biological tissues", *Optics Express*, Jan. 12, 2004, vol. 12, No. 1, pp. 208-219.
- Office Action dated Mar. 28, 2007 for U.S. Appl. No. 11/241,907.
- Office Action dated May 23, 2007 for U.S. Appl. No. 10/406,751.
- Office Action dated May 23, 2007 for U.S. Appl. No. 10/551,735.
- PCT International Search Report and Written Opinion for Application No. PCT/US2007/061815 dated Aug. 2, 2007.
- Sir Randall, John et al., "Brillouin scattering in systems of biological significance", *Phil. Trans. R. Soc. Lond. A* 293, 1979, pp. 341-348.
- Takagi, Yasunari, "Application of a microscope to Brillouin scattering spectroscopy", *Review of Scientific Instruments*, No. 12, Dec. 1992, pp. 5552-5555.
- Lees, S. et al., "Studies of Compact Hard Tissues and Collagen by Means of Brillouin Light Scattering", *Connective Tissue Research*, 1990, vol. 24, pp. 187-205.
- Berovic, N. "Observation of Brillouin scattering from single muscle fibers", *European Biophysics Journal*, 1989, vol. 17, pp. 69-74.
- PCT International Search Report and Written Opinion for Application No. PCT/US2007/062465 dated Aug. 8, 2007.
- Pyhtila John W. et al., "Rapid, depth-resolved light scattering measurements using Fourier domain, angle-resolved low coherence interferometry", *Optics Society of America*, 2004.
- Pyhtila John W. et al., "Determining nuclear morphology using an improved angle-resolved low coherence interferometry system", *Optics Express*, Dec. 15, 2003, vol. 11, No. 25, pp. 3473-3484.
- Desjardins A.E., et al., "Speckle reduction in OCT using massively-parallel detection and frequency-domain ranging", *Optics Express*, May 15, 2006, vol. 14, No. 11, pp. 4736-4745.
- Nadkarni, Seemantini K., et al., "Measurement of fibrous cap thickness in atherosclerotic plaques by spatiotemporal analysis of laser speckle images", *Journal of Biomedical Optics*, vol. 11 Mar./Apr. 2006, pp. 021006-1-021006-8.
- PCT International Search Report and Written Opinion for Application No. PCT/US2007/066017 dated Aug. 30, 2007.
- Yamanari M. et al., "Polarization sensitive Fourier domain optical coherence tomography with continuous polarization modulation", *Proc. of SPIE*, vol. 6079, 2006.
- Zhang Jun et al., "Full range polarization-sensitive Fourier domain optical coherence tomography", *Optics Express*, Nov. 29, 2004, vol. 12, No. 24, pp. 6033-6039.
- European Patent Office Search report for Application No. 01991092.6-2305 dated Jan. 12, 2006.
- Office Action dated Jul. 7, 2010 for U.S. Appl. No. 11/624,277.
- Montag Ethan D., "Parts of the Eye" online textbook for JIMG 774: Vision & Psychophysics, download on Jun. 23, 2010 from http://www.cis.rit.edu/people/faculty/montag/vandplite/pages/chap_8/ch8p3.html.
- Office Action dated Jul. 16, 2010 for U.S. Appl. No. 11/445,990.
- Office Action dated Jul. 20, 2010 for U.S. Appl. No. 11/625,135.
- Office Action dated Aug. 5, 2010 for U.S. Appl. No. 11/623,852.
- Chinese office action dated Aug. 4, 2010 for CN 200780005949.9.
- Chinese office action dated Aug. 4, 2010 for CN 200780016266.3.
- Zhang et al., "Full Range Polarization-Sensitive Fourier Domain Optical Coherence Tomography" *Optics Express*, Nov. 29, 2004, vol. 12, No. 24.
- Office Action dated Aug. 27, 2010 for U.S. Appl. No. 11/569,790.
- Office Action dated Aug. 31, 2010 for U.S. Appl. No. 11/677,278.
- Office Action dated Sep. 3, 2010 for U.S. Appl. No. 12/139,314.
- Yong Zhao et al: "Virtual Data Grid Middleware Services for Data-Intensive Science", *Concurrency and Computation: Practice and Experience*, Wiley, London, GB, Jan. 1, 2000, pp. 1-7, pp. 1532-0626.
- Swan et al., "Toward Nanometer-Scale Resolution in Fluorescence Microscopy using Spectral Self-Interference" *IEEE Journal. Selected Topics in Quantum Electronics* 9 (2) 2003, pp. 294-300.
- Moiseev et al., "Spectral Self-Interference Fluorescence Microscopy", *J. Appl. Phys.* 96 (9) 2004, pp. 5311-5315.
- Hendrik Verschueren, "Interference Reflection Microscopy in Cell Biology", *J. Cell Sci.* 75, 1985, pp. 289-301.
- Park et al., "Diffraction Phase and Fluorescence Microscopy", *Opt. Expr.* 14 (18) 2006, pp. 8263-8268.
- Swan et al. "High Resolution Spectral Self-Interference Fluorescence Microscopy", *Proc. SPIE* 4621, 2002, pp. 77-85.
- Sanchez et al., "Near-Field Fluorescence Microscopy Based on Two-Photon Excitation with Metal Tips", *Phys. Rev. Lett.* 82 (20) 1999, pp. 4014-4017.
- Wojtkowski, Maciej, Ph.D. "Three-Dimensional Retinal Imaging with High-Speed Ultrahigh-Resolution Optical Coherence Tomography" *Ophthalmology*, Oct. 2005, 112(10): 1734-1746.
- Vaughan, J.M. et al., "Brillouin Scattering, Density and Elastic Properties of the Lens and Cornea of the Eye", *Nature*, vol. 284, Apr. 3, 1980, pp. 489-491.
- Hess, S.T. et al. "Ultra-high Resolution Imaging by Fluorescence Photoactivation Localization Microscopy" *Biophysical Journal* vol. 91, Dec. 2006, 4258-4272.
- Fernandez-Suarez, M. et al., "Fluorescent Probes for super-Resolution Imaging in Living Cells" *Nature Reviews Molecular Cell Biology* vol. 9, Dec. 2008.
- Extended European Search Report mailed Dec. 14, 2010 for EP 10182301.1.
- S. Hell et al., "Breaking the diffraction resolution limit by stimulated-emission—stimulated-emission-depletion fluorescence microscopy," *Optics Letters*. 19:495 (1995) and *Ground State Depletion (GSD)*.
- S. Hell et al. "Ground-State-Depletion fluorescence microscopy—a concept for breaking the diffraction resolution limit," *Applied Physics B*. 60:780 (1994) *fluorescence microscopy, photo-activated localization microscopy (PALM)*.
- E. Betzig et al. "Imaging intracellular fluorescent proteins at nanometer resolution," *Science* 313:1642 (2006), *stochastic optical reconstruction microscopy (STORM)*.
- M. Rust et al. "Sub-diffraction-limited imaging by stochastic optical reconstruction microscopy (STORM)," *Nature Methods* 3:783 (2006), and *structured illumination microscopy (SIM)*.
- B. Bailey et al. "Enhancement of Axial Resolution in Fluorescence Microscopy by Standing-Wave Excitation," *Nature* 366:44 (1993).

(56)

References Cited

OTHER PUBLICATIONS

- M. Gustafsson "Surpassing the lateral resolution limit by a factor of two using structured illumination microscopy," *Journal of Microscopy* 198:82 (2000).
- M. Gustafsson "Nonlinear structured illumination microscopy: Wide-field fluorescence imaging with theoretically unlimited resolution," *PNAS* 102:13081 (2005).
- R. Thompson et al. "Precise nanometer localization analysis for individual fluorescent probes," *Biophysical Journal* 82:2775 (2002).
- K. Drabe et al. "Localization of Spontaneous Emission in front of a mirror," *Optics Communications* 73:91 (1989).
- Swan et al. "Toward nanometer-scale resolution in fluorescence microscopy using spectral self-interference," *IEEE Quantum Electronics* 9:294 (2003).
- C. Joo, et al. "Spectral Domain optical coherence phase and multiphoton microscopy," *Optics Letters* 32:623 (2007).
- Virmani et al., "Lesions from sudden coronary death: A comprehensive morphological classification scheme for atherosclerotic lesions," *Arterioscler. Thromb. Vase. Bio.*, 20:1262-75 (2000).
- Gonzalez, R.C. and Wintz, P., "Digital Image Processing" Addison-Wesley Publishing Company, Reading MA, 1987.
- V. Tuchin et al., "Speckle interferometry in the measurements of fibrotissues vibrations," *SPIE*, 1647: 125 (1992).
- A.A. Bednov et al., "Investigation of Statistical Properties of Lymph Flow Dynamics Using Speckle-Microscopy," *SPIE*, 2981: 181-90 (1997).
- Feng et al., "Mesoscopic Conductors and Correlations in Laser Speckle Patterns" *Science, New Series*, vol. 251, No. 4994, pp. 633-639 (Feb. 8, 1991).
- Lee et al., "The Unstable Atheroma," *Arteriosclerosis, Thrombosis & Vascular Biology*, 17:1859-67 (1997).
- International Search report dated Apr. 29, 2011 for PCT/US2010/051715.
- International Search report dated Sep. 13, 2010 for PCT/US2010/023215.
- International Search Report dated Jul. 28, 2011 for PCT/US2010/059534.
- International Search report dated Nov. 18, 2011 for PCT/US2011/027450.
- International Search report dated Nov. 18, 2011 for PCT/US2011/027437.
- International Search report dated Nov. 22, 2011 for PCT/US2011/027421.
- Fu L et al: Double-Clad Photonic Crystal Fiber Coupler for compact Nonlinear Optical Microscopy Imaging, *Optics Letters*, OSA, Optical Society of America, vol. 31, No. 10, May 15, 2006, pp. 1471-1473.
- Japanese language Appeal Decision dated Jan. 10, 2012 for JP 2006-503161.
- Japanese Notice of Grounds for Rejection dated Oct. 28, 2011 for JP2009-294737.
- Japanese Notice of Grounds for Rejection dated Dec. 28, 2011 for JP2008-535793.
- Japanese Notice of Reasons for Rejection dated Dec. 12, 2011 for JP 2008-533712.
- International Search Report and Written Opinion mailed Feb. 9, 2012 based on PCT/US2011/034810.
- Japanese Notice of Reasons for Rejection dated Mar. 27, 2012 for JP 2003-102672.
- Japanese Notice of Reasons for Rejection dated May 8, 2012 for JP 2008-533727.
- Korean Office Action dated May 25, 2012 for KR 10-2007-7008116.
- Japanese Notice of Reasons for Rejection dated May 21, 2012 for JP 2008-551523.
- Japanese Notice of Reasons for Rejection dated Jun. 20, 2012 for JP 2009-546534.
- European Official Communication dated Aug. 1, 2012 for EP 10193526.0.
- European Search Report dated Jun. 25, 2012 for EP 10733985.5.
- Wieser, Wolfgang et al., "Multi-Megahertz OCT: High Quality 3D Imaging at 20 million A-Scans and 4.5 Gvoxels Per Second" Jul. 5, 2010, vol. 18, No. 14, *Optics Express*.
- European Communication Pursuant to EPC Article 94(3) for EP 07845206.7 dated Aug. 30, 2012.
- International Search Report and Written Opinion mailed Aug. 30, 2012 for PCT/US2012/035234.
- Giuliano, Scarcelli et al., "Three-Dimensional Brillouin Confocal Microscopy". *Optical Society of American*, 2007, CtuV5.
- Giuliano, Scarcelli et al., "Confocal Brillouin Microscopy for Three-Dimensional Mechanical Imaging." *Nat Photonics*, Dec. 9, 2007.
- Japanese Notice of Reasons for Rejections dated Oct. 10, 2012 for 2008-553511.
- W.Y. Oh et al: "High-Speed Polarization Sensitive Optical Frequency Domain Imaging with Frequency Multiplexing", *Optics Express*, vol. 16, No. 2, Jan. 1, 2008.
- Athey, B.D. et al., "Development and Demonstration of a Networked Telepathology 3-D Imaging, Databasing, and Communication System", 1998 ("C2"), pp. 5-17.
- D'Amico, A.V., et al. "Optical Coherence Tomography as a Method for Identifying Benign and Malignant Microscopic Structures in the Prostate Gland", *Urology*, vol. 55, Issue 5, May 2000 ("C3"), pp. 783-787.
- Tearney, G.J. et al., "In Vivo Endoscopic Optical Biopsy with Optical Coherence Tomography", *Science*, vol. 276, No. 5321, Jun. 27, 1997 ("C6"), pp. 2037-2039.
- Japanese Notice of Reasons for Rejections dated Oct. 2, 2012 for 2007-543626.
- Canadian Office Action dated Oct. 10, 2012 for 2,514,189.
- Japanese Notice of Reasons for Rejections dated Nov. 9, 2012 for JP 2007-530134.
- Japanese Notice of Reasons for Rejections dated Nov. 27, 2012 for JP 2009-554772.
- Japanese Notice of Reasons for Rejections dated Oct. 11, 2012 for JP 2008-533712.
- Yoden, K. et al. "An Approach to Optical Reflection Tomography Along the Geometrical Thickness," *Optical Review*, vol. 7, No. 5, Oct. 1, 2000.
- International Search Report and Written Opinion mailed Oct. 25, 2012 for PCT/US2012/047415.
- Joshua, Fox et al: "Measuring Primate RNFL Thickness with OCT", *IEEE Journal of Selected Topics in Quantum Electronics*, IEEE Service Center, Piscataway, NJ, US, vol. 7, No. 6, Nov. 1, 2001.
- European Official Communication dated Feb. 6, 2013 for 04822169.1.
- International Search Report mailed Jan. 31, 2013 for PCT/US2012/061135.
- Viliyarn K. Pratt. *Lazernye Sistemy Svyazi*. Moskva, Izdatelstvo "Svyaz", 1972. p. 68-70.
- International Search Report and Written Opinion mailed Jan. 31, 2013 for PCT/US2012/060843.
- European Search Report mailed on Mar. 11, 2013 for EP 10739129.4.
- Huber, R et al: "Fourier Domain Mode Locked Lasers for OCT Imaging at up to 290 kHz Sweep Rates", *Proceedings of SPIE*, SPIE—International Society for Optical Engineering, US, vol. 5861, No. 1, Jan. 1, 2005.
- M. Kourogi et al; "Programmable High Speed (1MHz) Vernier-mode-locked Frequency-Swept Laser for OCT Imaging", *Proceedings of SPIE*, vol. 6847, Feb. 7, 2008.
- Notice of Reasons for Rejection dated Feb. 5, 2013 for JP 2008-509233.
- Notice of Reasons for Rejection dated Feb. 19, 2013 for JP 2008-507983.
- European Extended Search Report mailed Mar. 26, 2013 for EP 09825421.1.
- Masahiro, Yamanari et al: "polarization-Sensitive Swept-Source Optical Coherence Tomography with Continuous Source Polarization Modulation", *Optics Express*, vol. 16, No. 8, Apr. 14, 2008.
- European Extended Search Report mailed on Feb. 1, 2013 for EP 12171521.3.

(56)

References Cited

OTHER PUBLICATIONS

Nakamura, Koichiro et al., "A New Technique of Optical Ranging by a Frequency-Shifted Feedback Laser", IEEE Photonics Technology Letters, vol. 10, No. 12, pp. 1041-1135, Dec. 1998.

Lee, Seok-Jeong et al., "Ultrahigh Scanning Speed Optical Coherence Tomography Using Optical Frequency Comb Generators", The Japan Society of Applied Physics, vol. 40 (2001).

Kinoshita, Masaya et al., "Optical Frequency-Domain Imaging Microprofilometry with a Frequency-Tunable Liquid-Crystal Fbry-Perot Etalon Device" Applied Optics, vol. 38, No. 34, Dec. 1, 1999. Notice of Reasons for Rejection mailed on Apr. 16, 2013 for JP 2009-510092.

Bachmann A.H. et al: "Heterodyne Fourier Domain Optical Coherence Tomography for Full Range Probing with High Axial Resolution", Optics Express, OSA, vol. 14, No. 4, Feb. 20, 2006.

European Search Report for 12194876.4 dated Feb. 1, 2013.

International Search Report and Written Opinion for PCT/US2013/022136.

Thomas J. Flotte: "Pathology Correlations with Optical Biopsy Techniques", Annals of the New York Academy of Sciences, Wiley-Blackwell Publishing, INC. SU, vol. 838, No. 1, Feb. 1, 1998, pp. 143-149.

Constance R. Chu et al: Arthroscopic Microscopy of Articular Cartilage Using Optical Coherence Tomography, American Journal of Sports Medicine, American Orthopedic Society for Sports Medicine, Waltham, MA, Vo. 32, No. 9, Apr. 1, 2004.

Bouma B E et al: Diagnosis of Specialized Intestinal Metaplasia of the Esophagus with Optical Coherence Tomography, Conference on Lasers and Electro-Optics. Technical Digest. OSA, US, vol. 56, May 6, 2001.

Shen et al: "Ex Vivo Histology-Correlated Optical Coherence Tomography in the Detection of Transmural Inflammation in Crohn's Disease", Clinical Gastroenterology and Hepatology, vol. 2, No. 9, Sep. 1, 2004.

Shen et al: "In Vivo Colonscopic Optical Coherence Tomography for Transmural Inflammation in Inflammatory Bowel Disease", Clinical Gastroenterology and Hepatology, American Gastroenterological Association, US, vol. 2, No. 12, Dec. 1, 2004.

Ge Z et al: "Identification of Colonic Dysplasia and Neoplasia by Diffuse Reflectance Spectroscopy and Pattern Recognition Techniques", Applied Spectroscopy, The Society for Applied Spectroscopy, vol. 52, No. 6, Jun. 1, 1998.

Elena Zagaynova et al: "Optical Coherence Tomography: Potentialities in Clinical Practice", Proceedings of SPIE, Aug. 20, 2004.

Westphal et al: "Correlation of Endoscopic Optical Coherence Tomography with Histology in the Lower-GI Tract", Gastrointestinal Endoscopy, Elsevier, NL, vol. 61, No. 4, Apr. 1, 2005.

Haggitt et al: "Barrett's Esophagus, Dysplasia, and Adenocarcinoma", Human Pathology, Saunders, Philadelphia, PA, US, vol. 25, No. 10, Oct. 1, 1994.

Gang Yao et al. "Monte Carlo Simulation of an Optical Coherence Tomography Signal in Homogenous Turbid Media," Physics in Medicine and Biology, 1999.

Murakami, K. "A Miniature Confocal Optical Scanning Microscopy for Endoscopes", Proceedings of SPIE, vol. 5721, Feb. 28, 2005, pp. 119-131.

Seok, H. Yun et al: "Comprehensive Volumetric Optical Microscopy in Vivo", Nature Medicine, vol. 12, No. 12, Jan. 1, 2007.

Baxter: "Image Zooming", Jan. 25, 2005, Retrieved from the Internet.

Qiang Zhou et al: "A Novel Machine Vision Application for Analysis and Visualization of Confocal Microscopic Images" Machine Vision and Applications, vol. 16, No. 2, Feb. 1, 2005.

Igor Gurov et al: (2007) "Full-field High-Speed Optical Coherence Tomography System for Evaluating Multilayer and Random Tissues", Proc. of SPIE, vol. 6618.

Igor Gurov et al: "High-Speed Signal Evaluation in Optical Coherence Tomography Based on Sub-Nyquist Sampling and Kalman Filtering Method" AIP Coherence Proceedings, vol. 860, Jan. 1, 2006.

Groot De P et al: "Three Dimensional Imaging by Sub-Nyquist Sampling of White-Light Interferograms", Optics Letters, vol. 18, No. 17, Sep. 1, 1993.

Third Office Action for Japanese Patent Application 2011-276472 dated on Jan. 13, 2015.

Fourth Office Action for Chinese Patent Application 200780009476.X dated on Nov. 4, 2014.

Third Office Action for European Patent Application 07845211.7 dated on Oct. 22, 2014.

Poneros er al: "Optical Coherence Tomography of the Biliary Tree During ERCP", Gastrointestinal Endoscopy, Elsevier, NL, vol. 55, No. 1, Jan. 1, 2002, pp. 84-88.

* cited by examiner

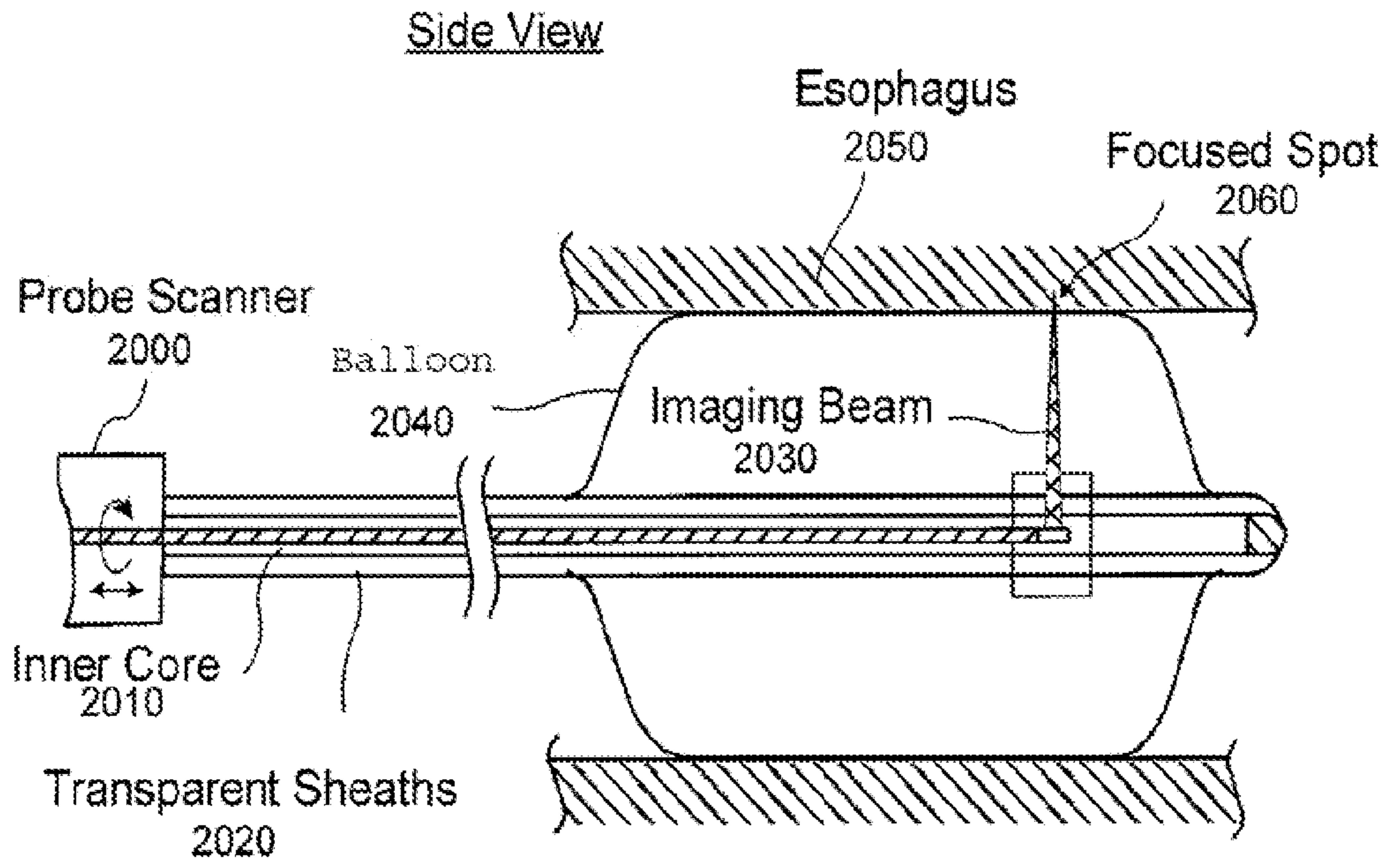

FIG. 1A

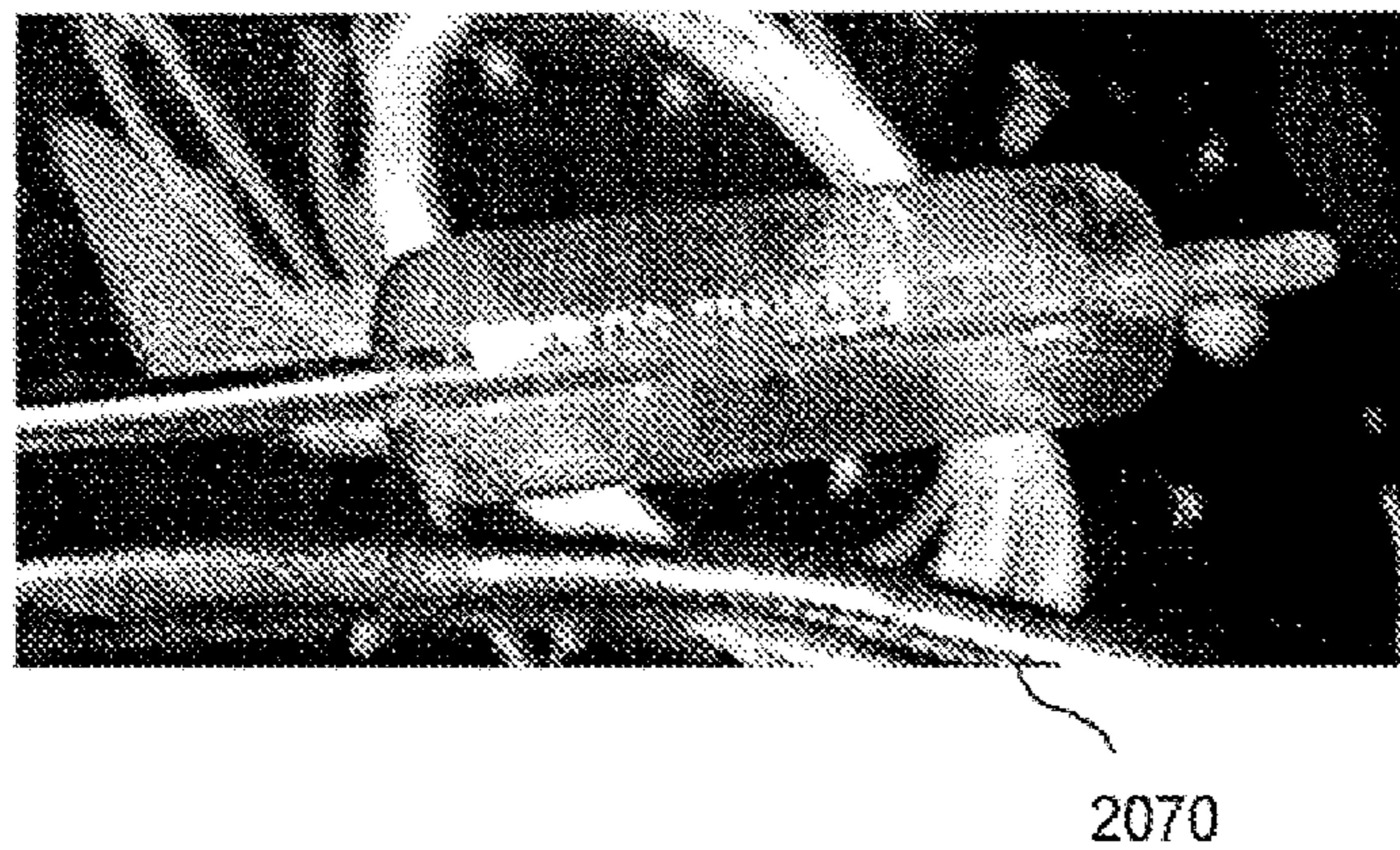

FIG. 1B

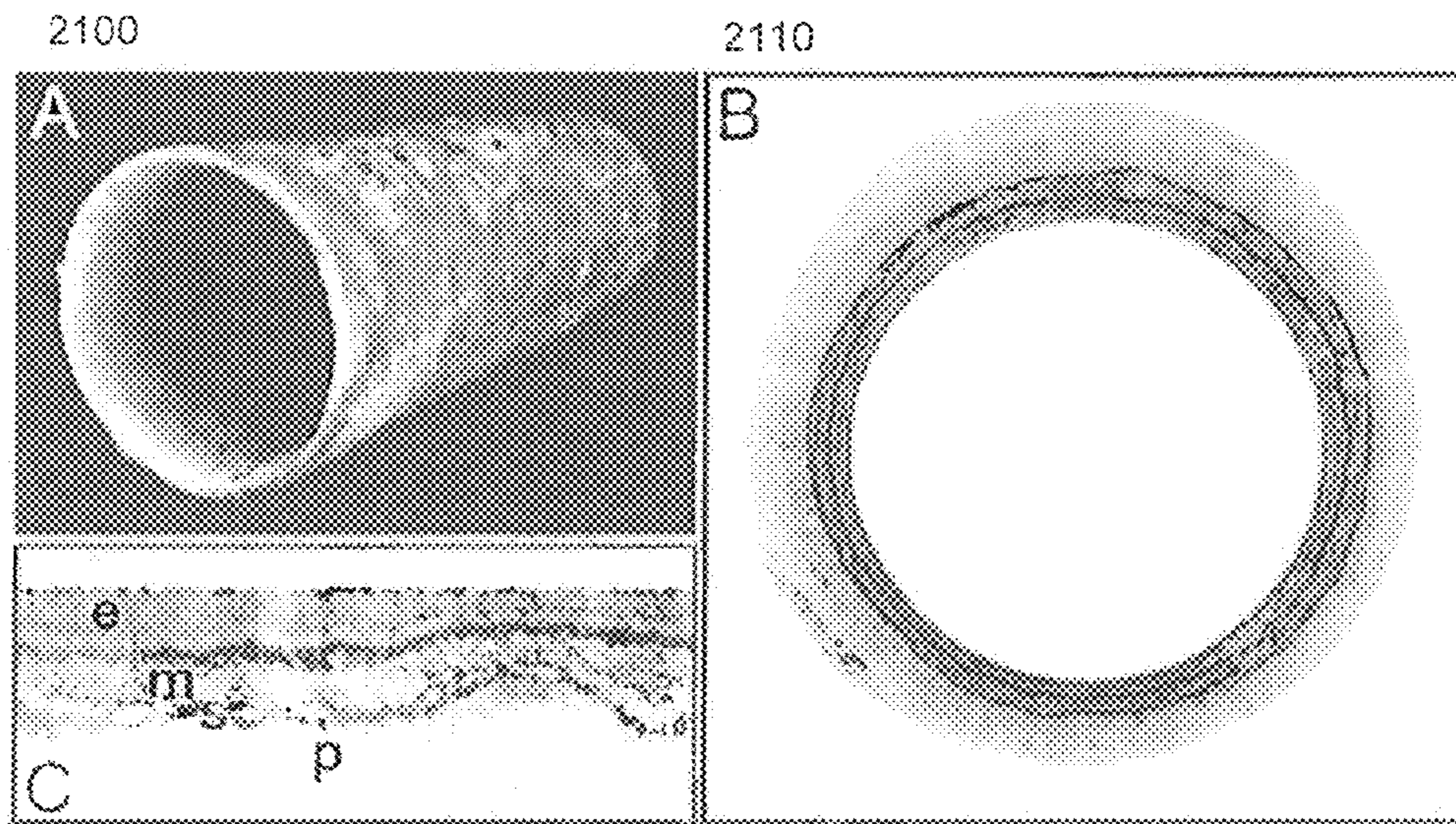

FIG. 2

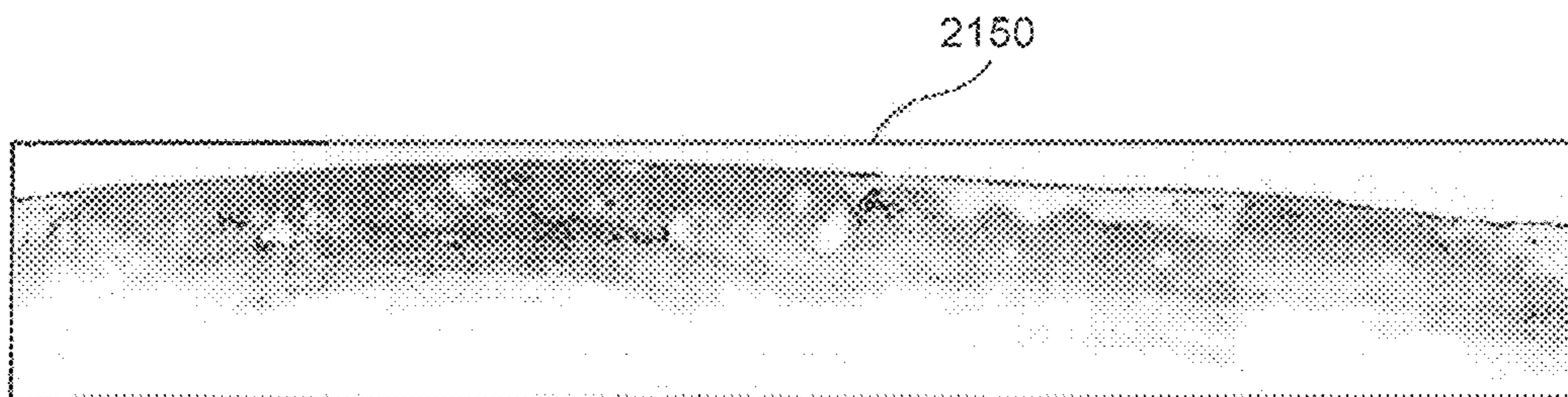

FIG. 3

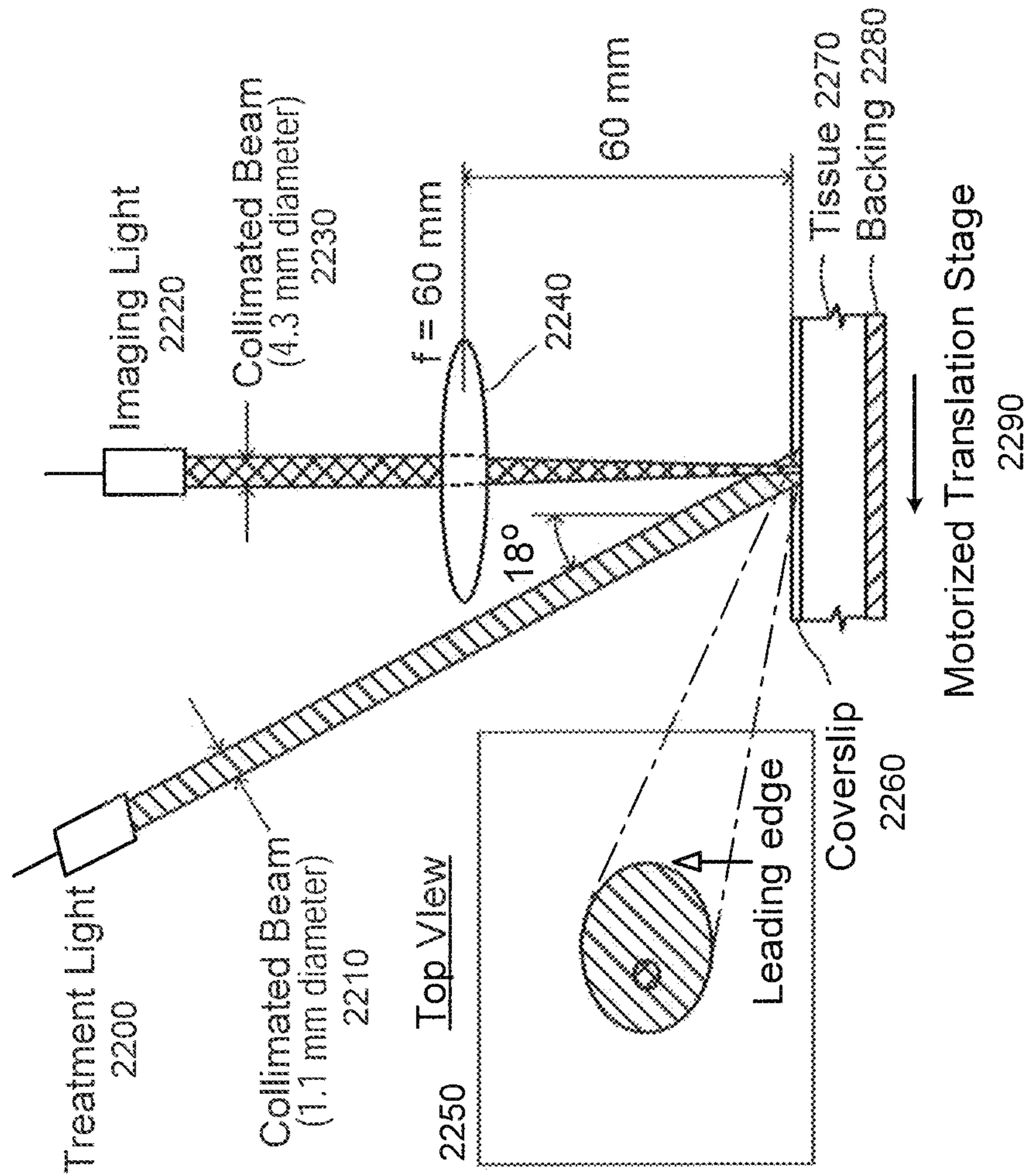

FIG. 4

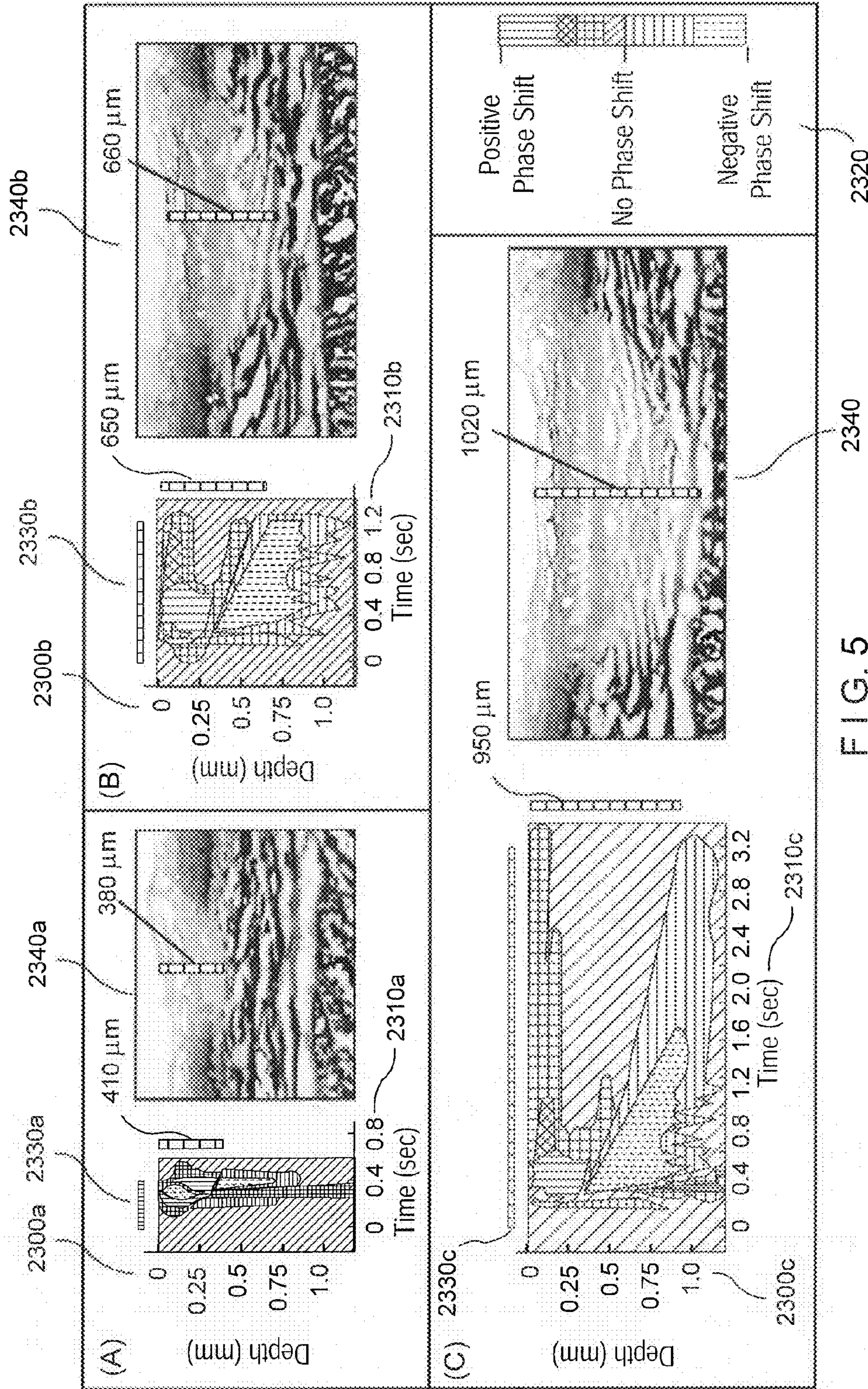

FIG. 5

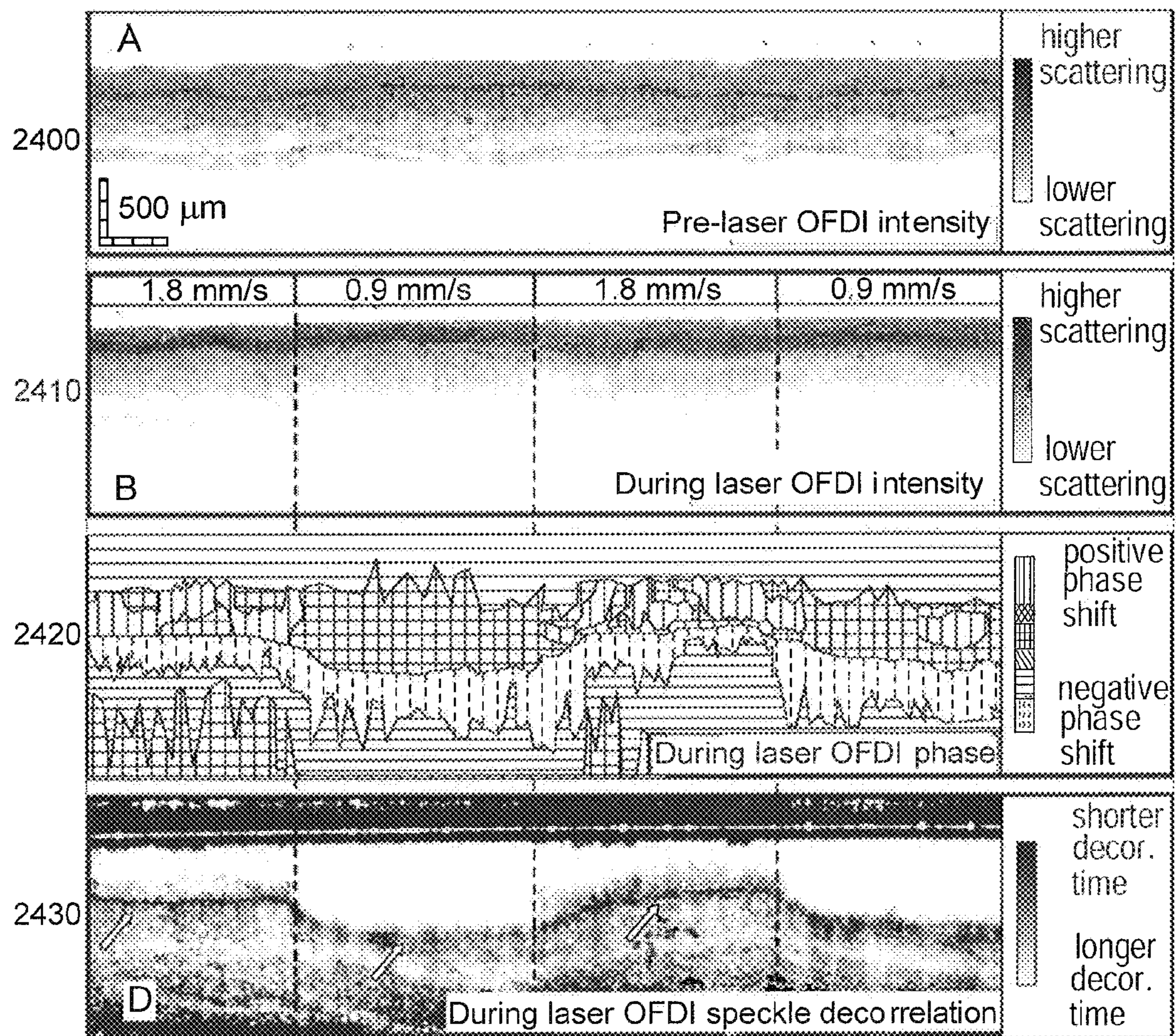

FIG. 6

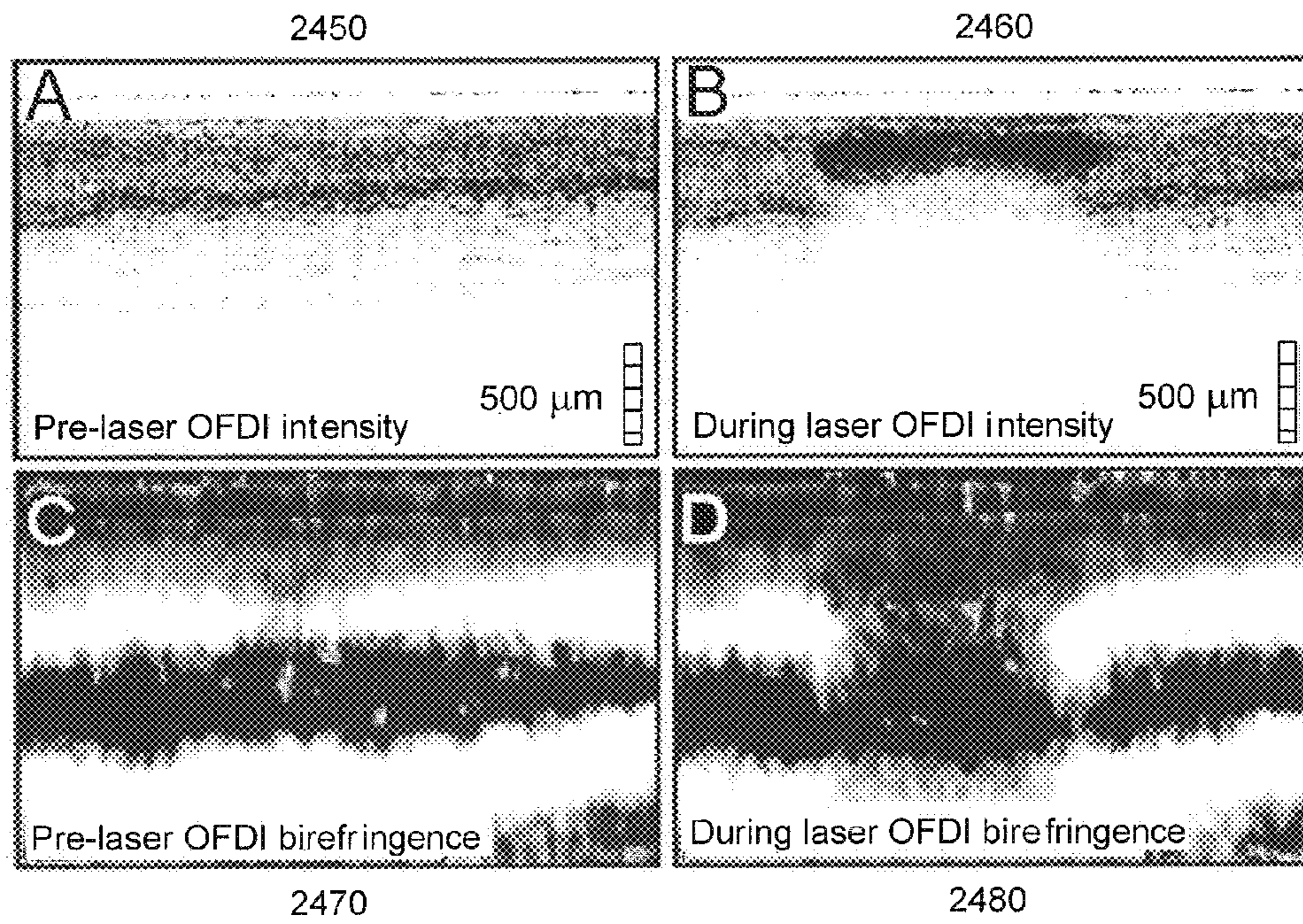

FIG. 7

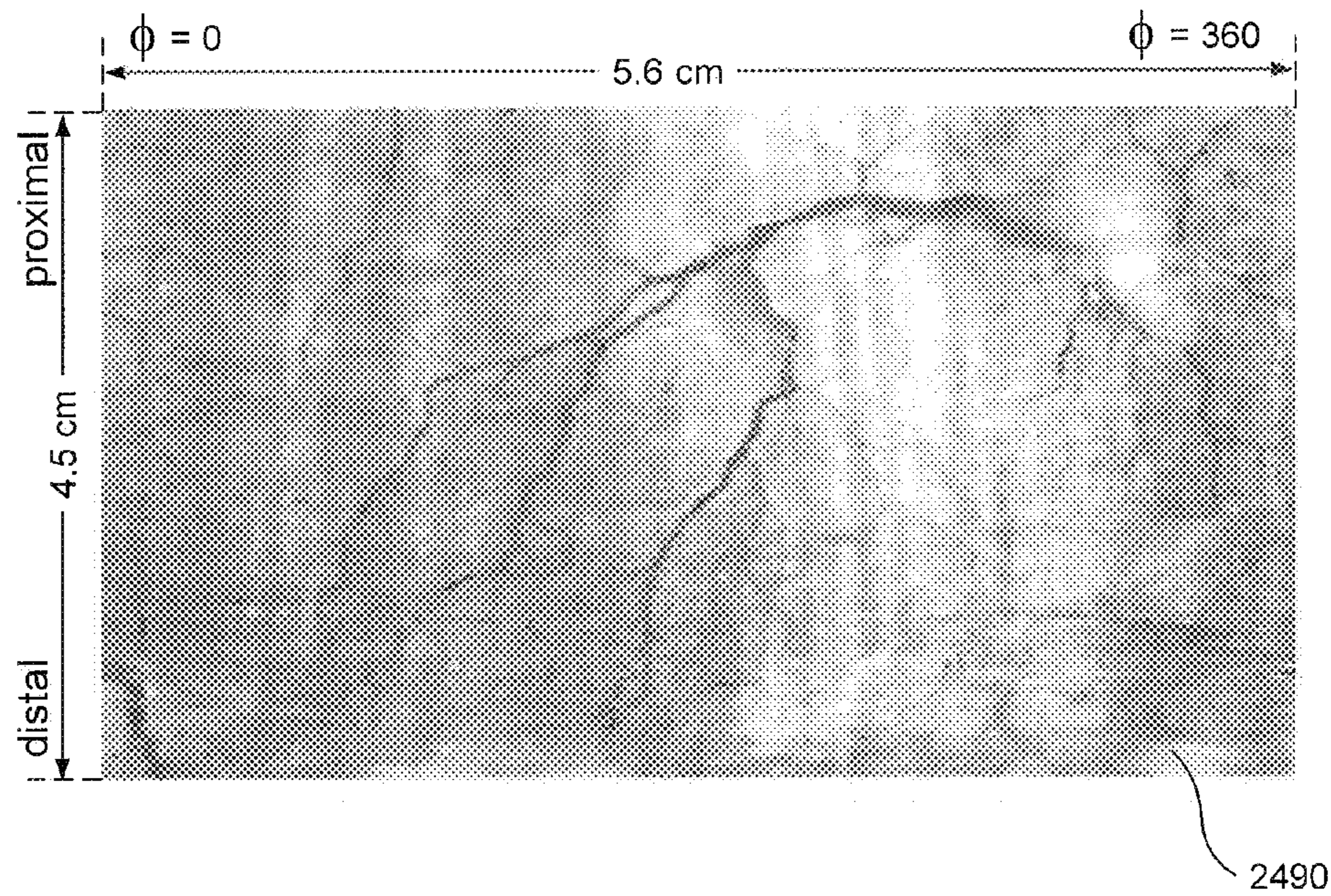

FIG. 8



FIG. 9

2590

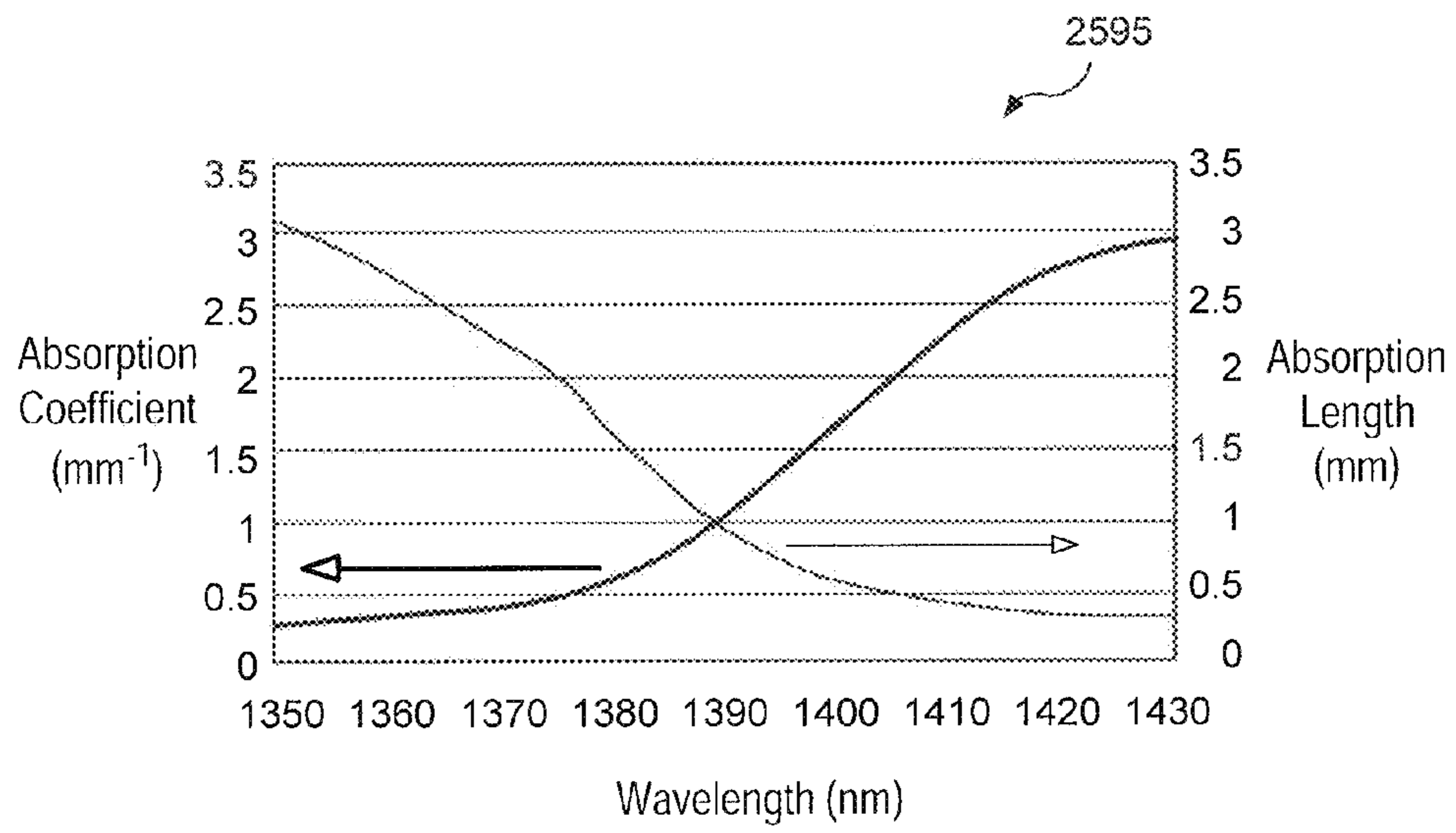

FIG. 10

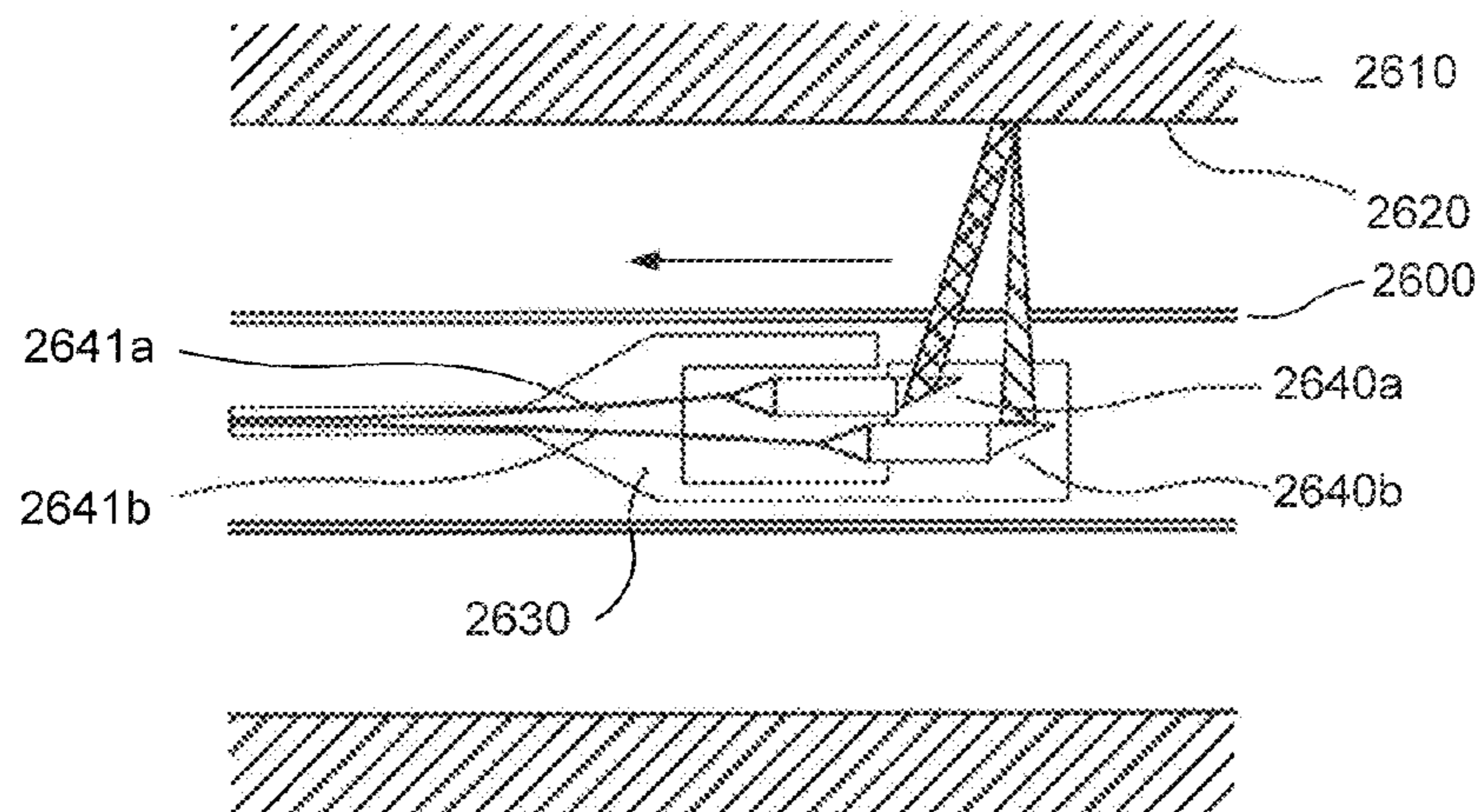

FIG. 11

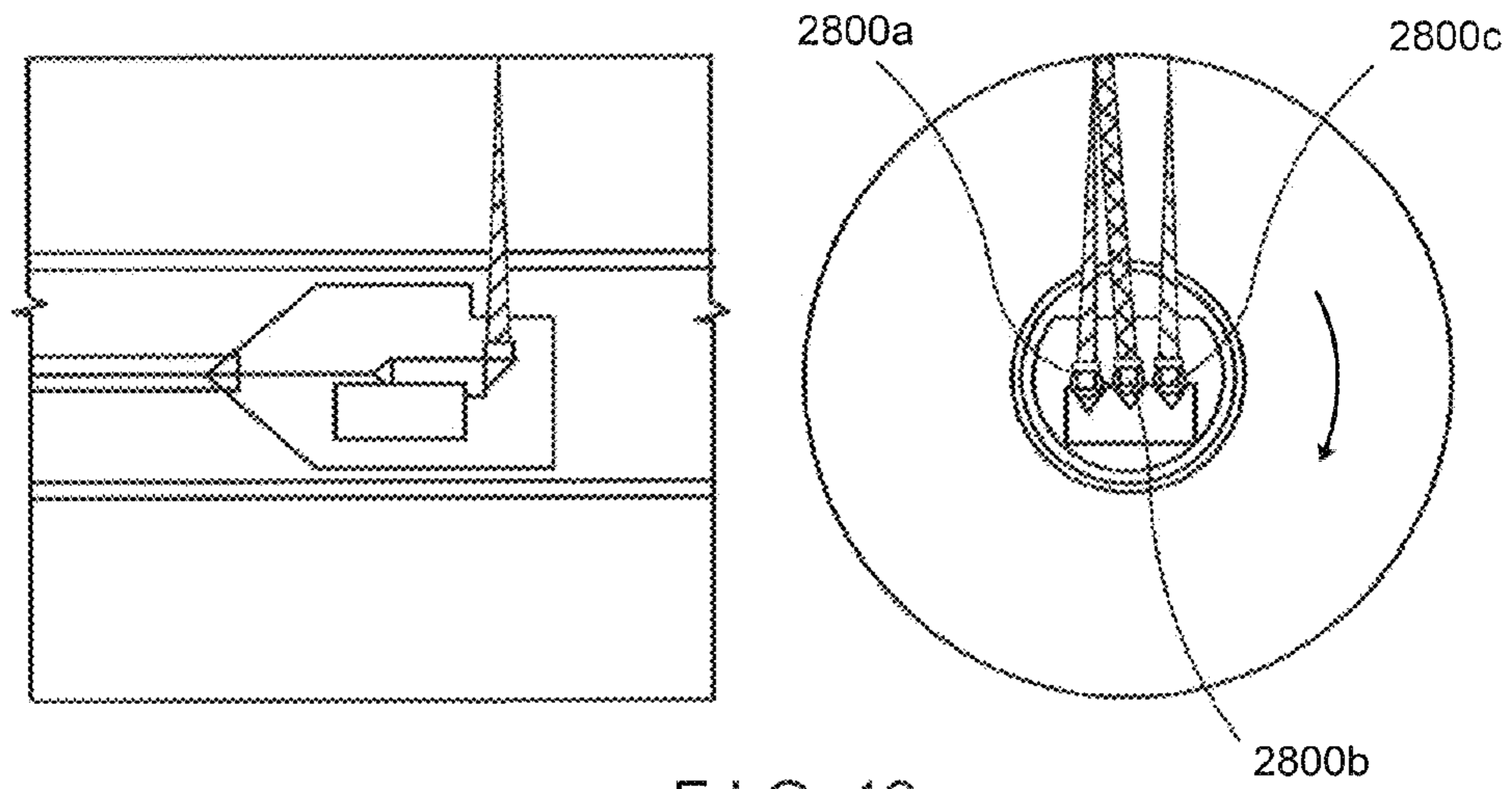

FIG. 12

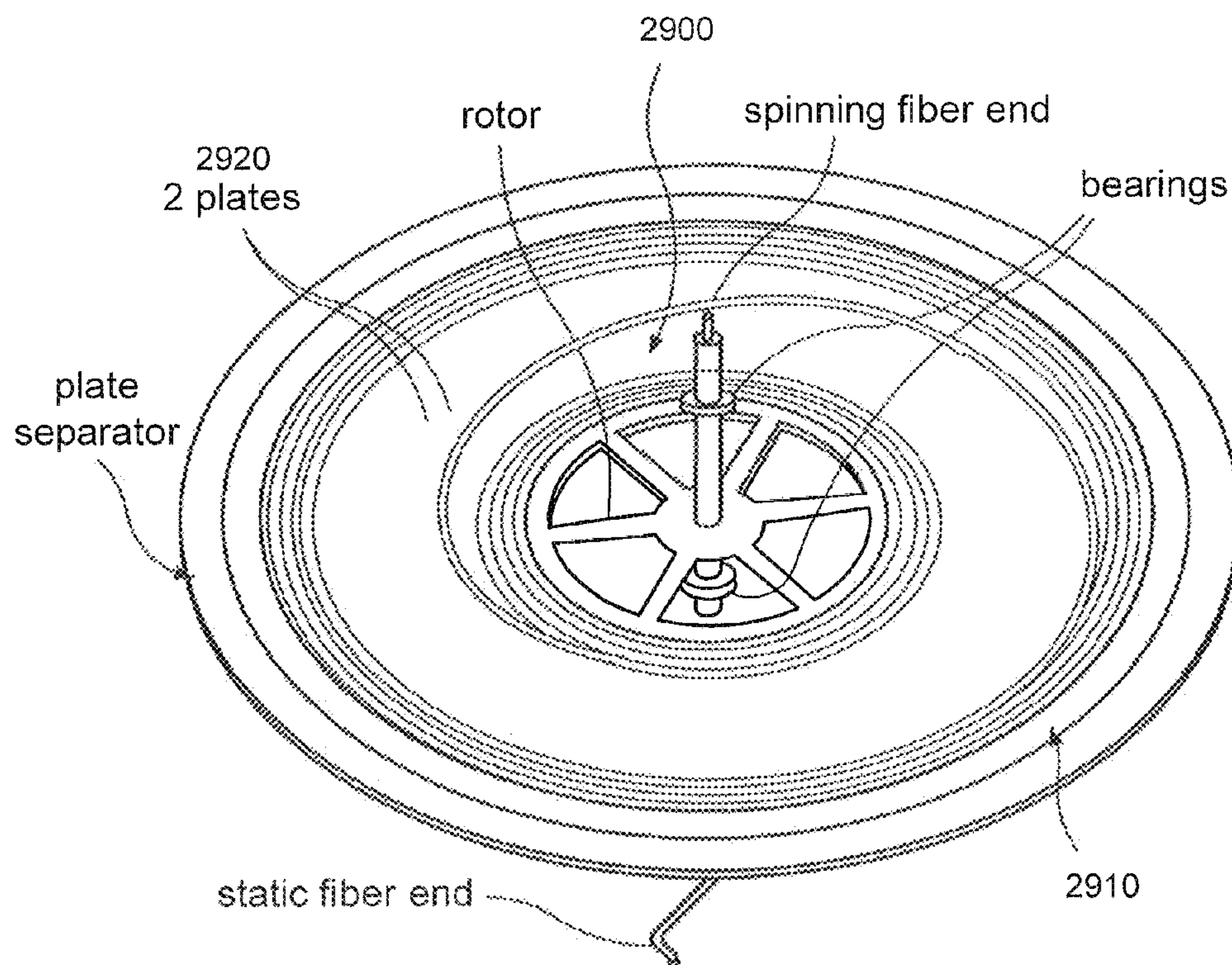

FIG. 13

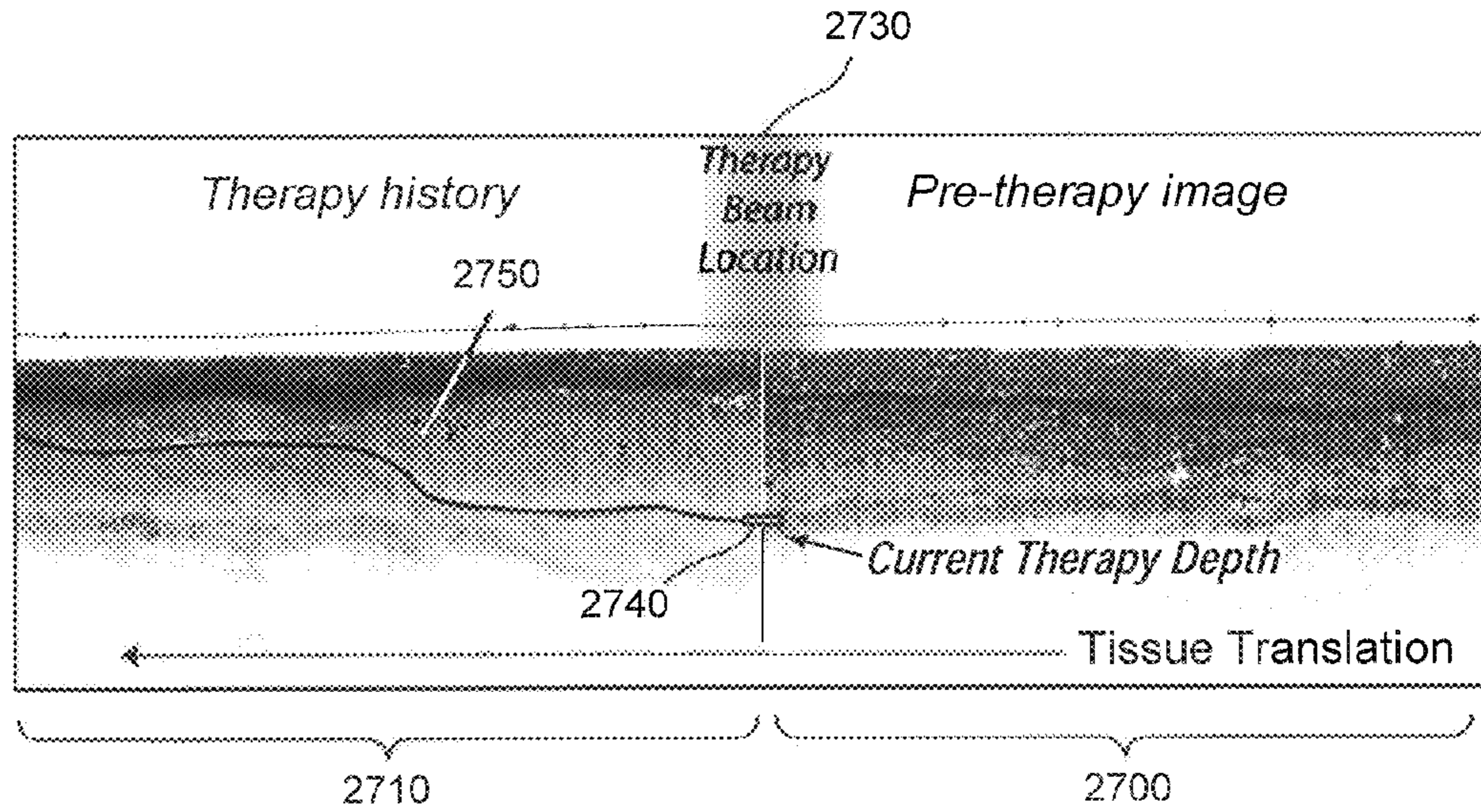

FIG. 14

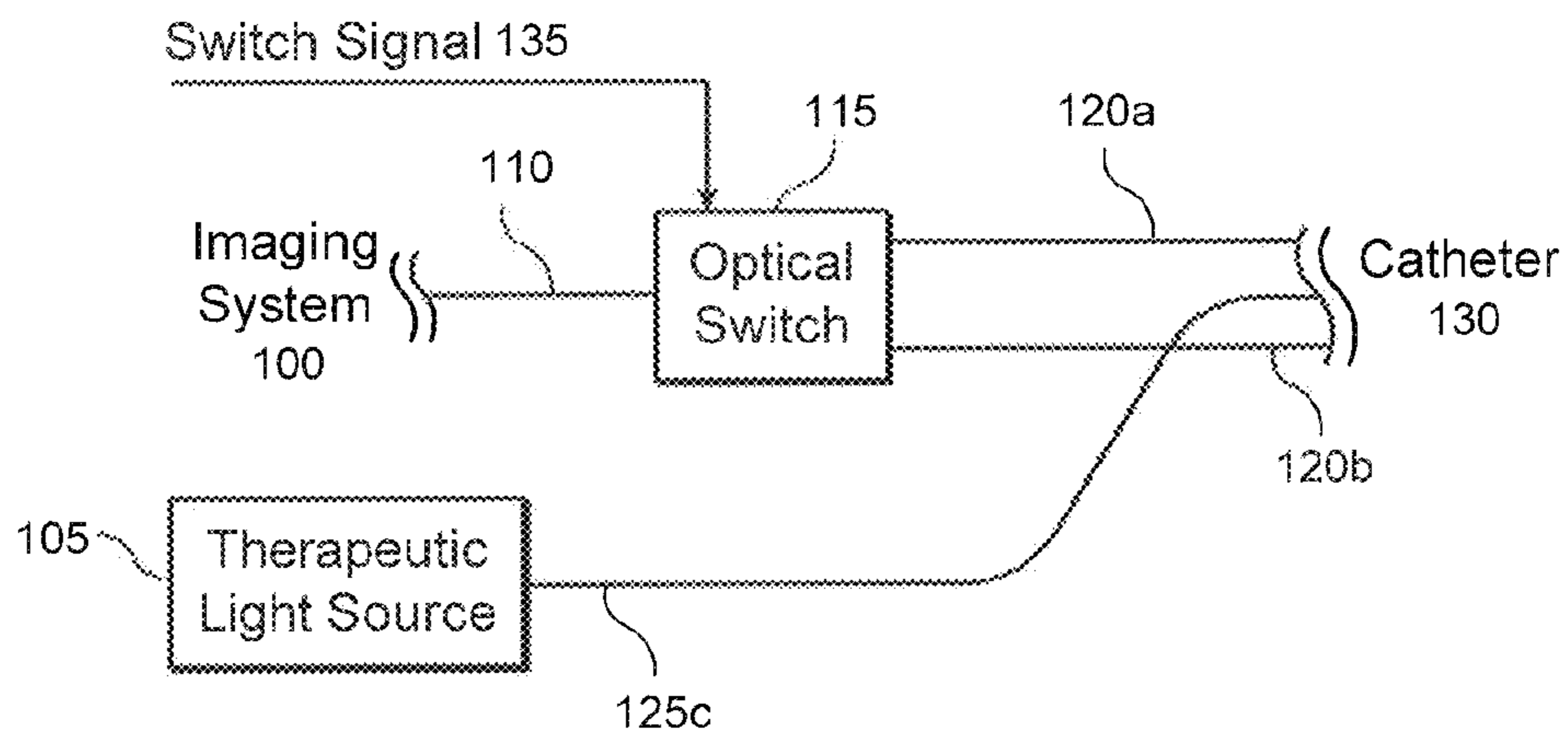

FIG. 15

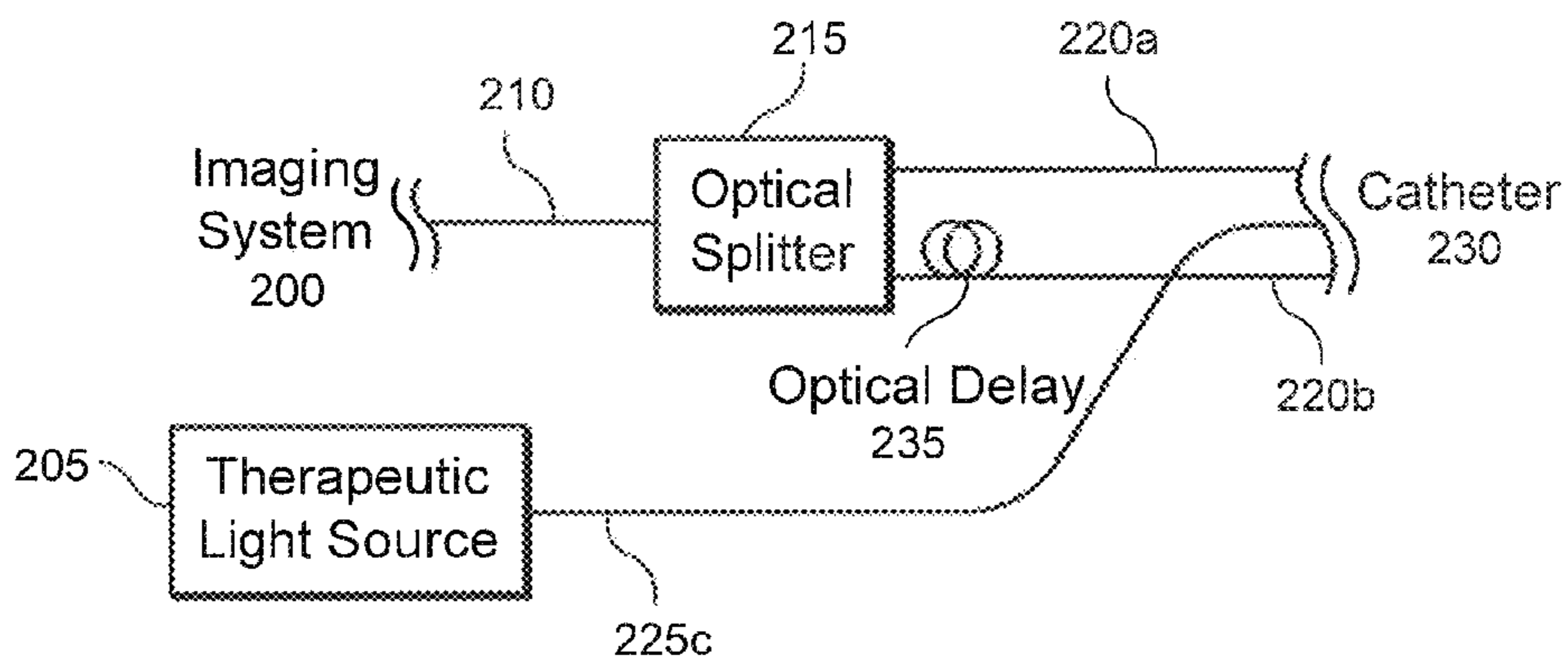

FIG. 16

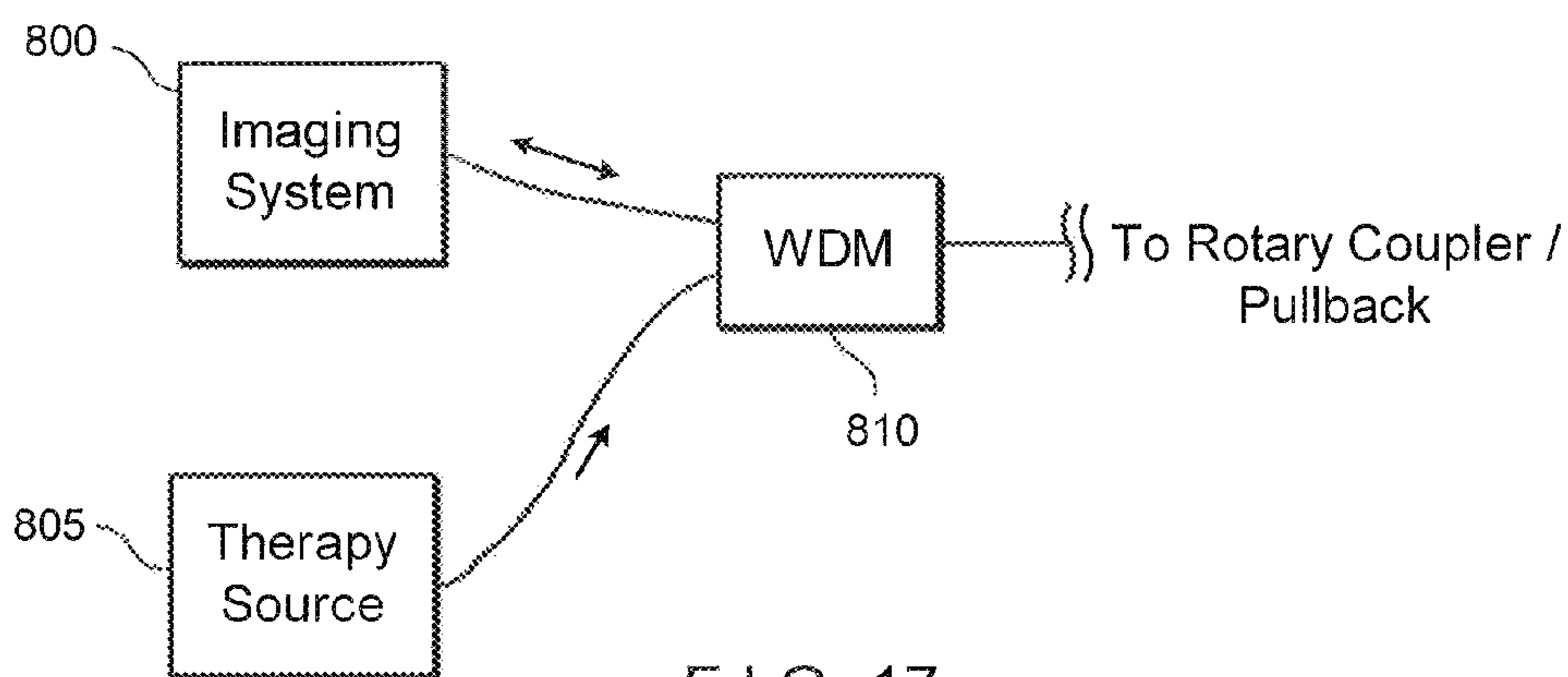

FIG. 17

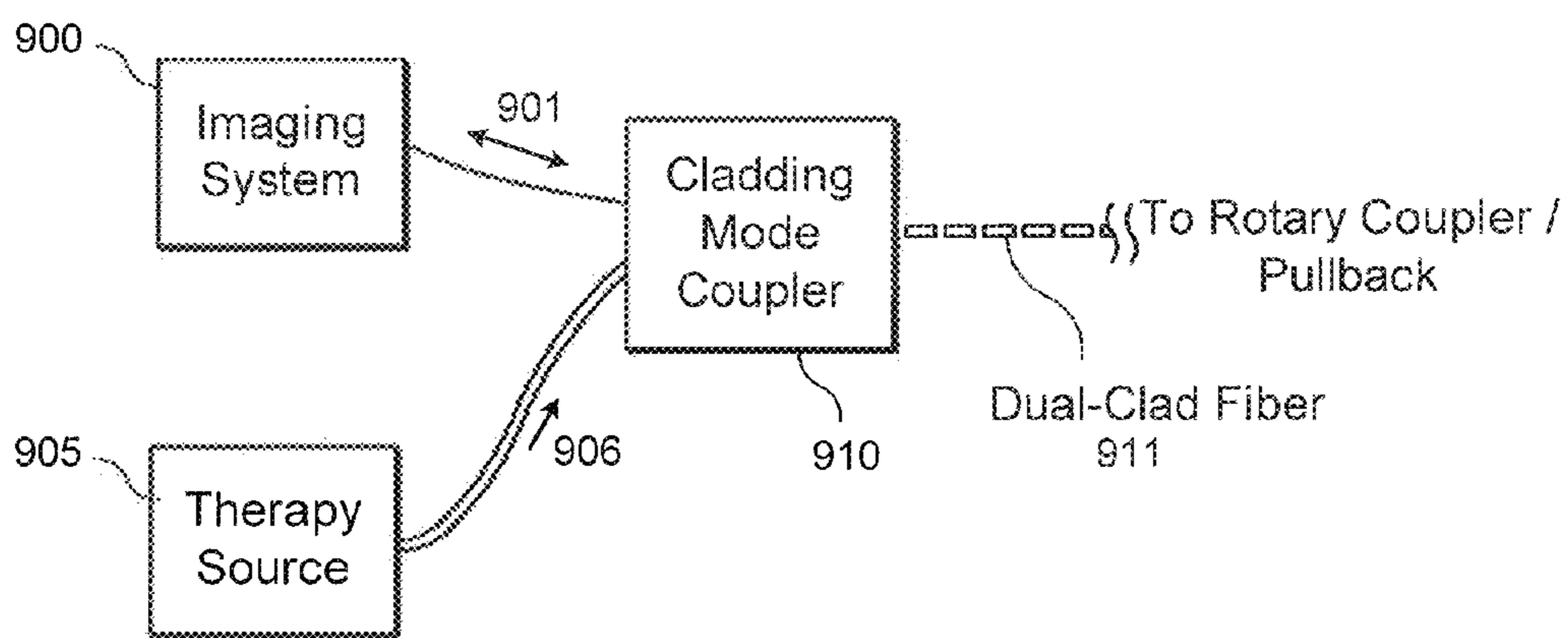

FIG. 18

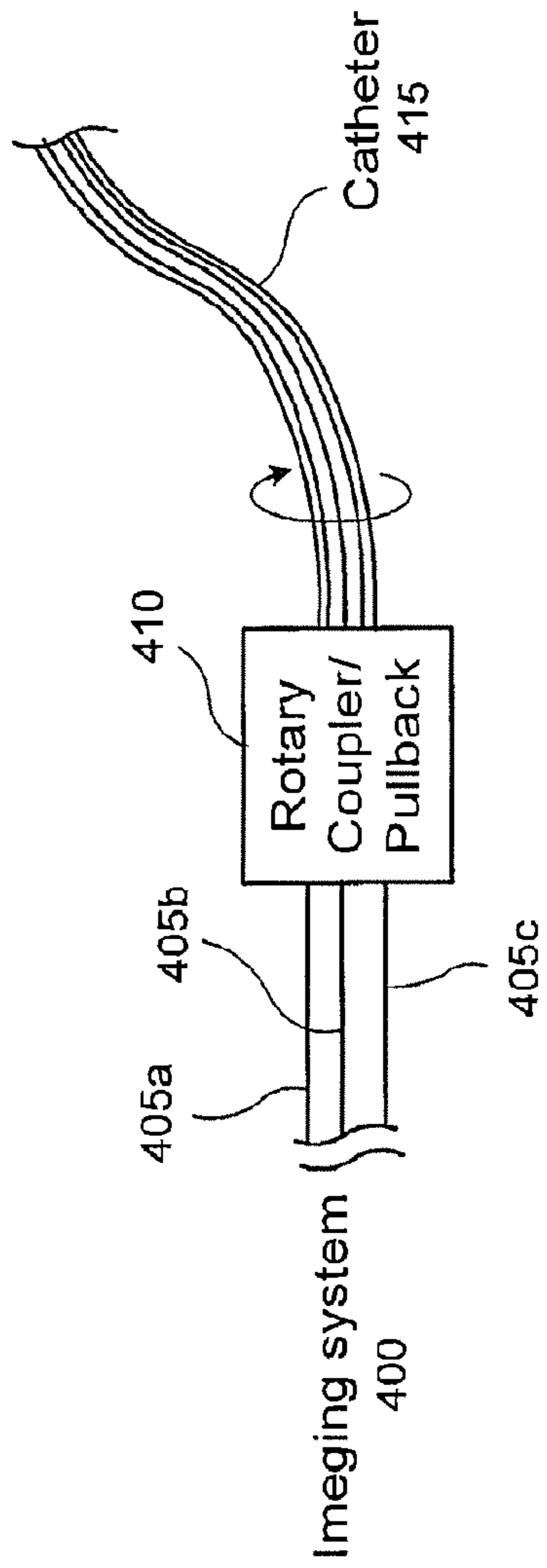

FIG. 19

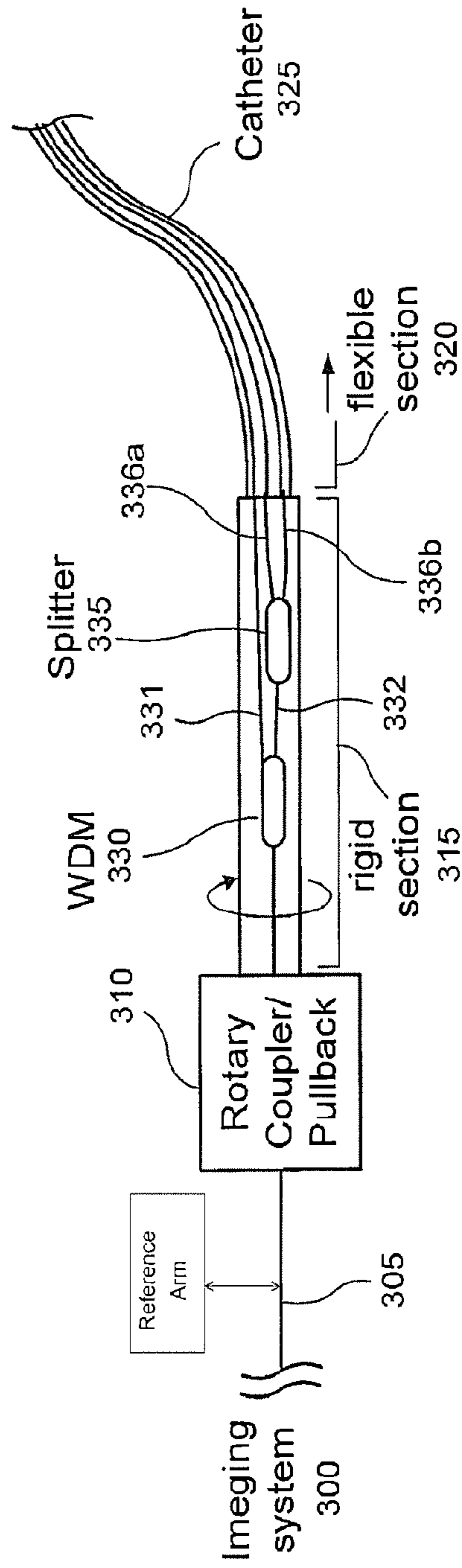

FIG. 20

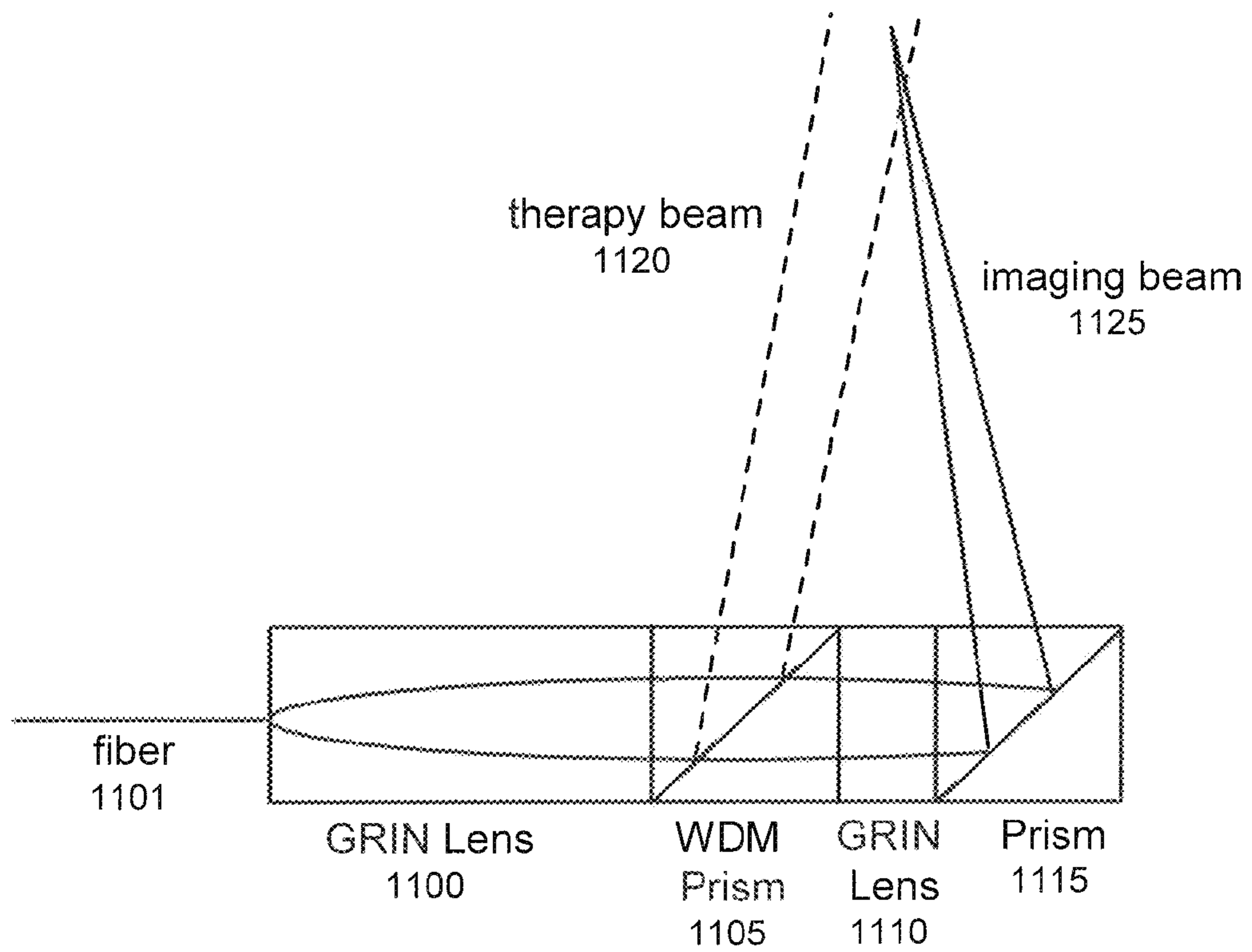

FIG. 21

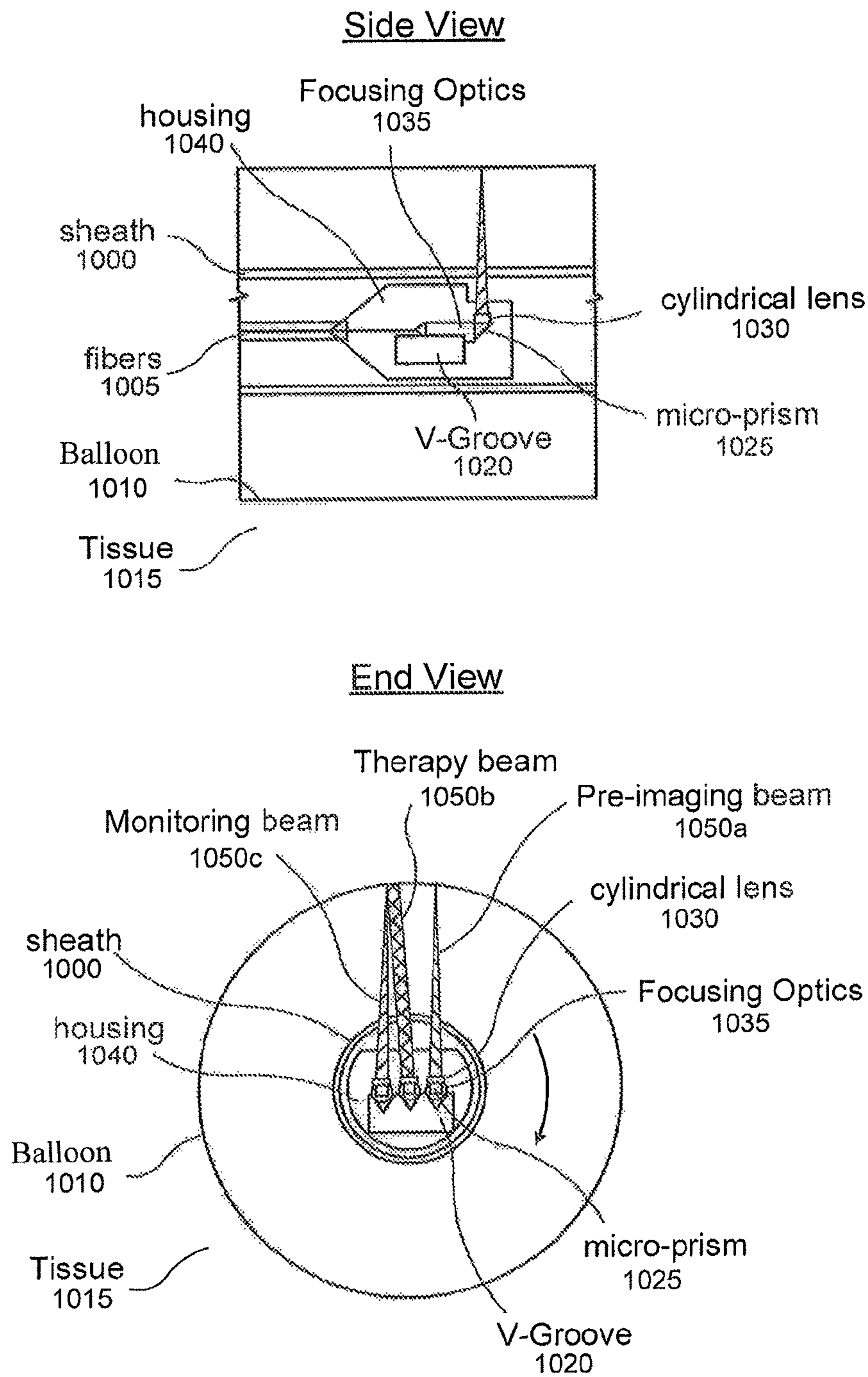

FIG. 22

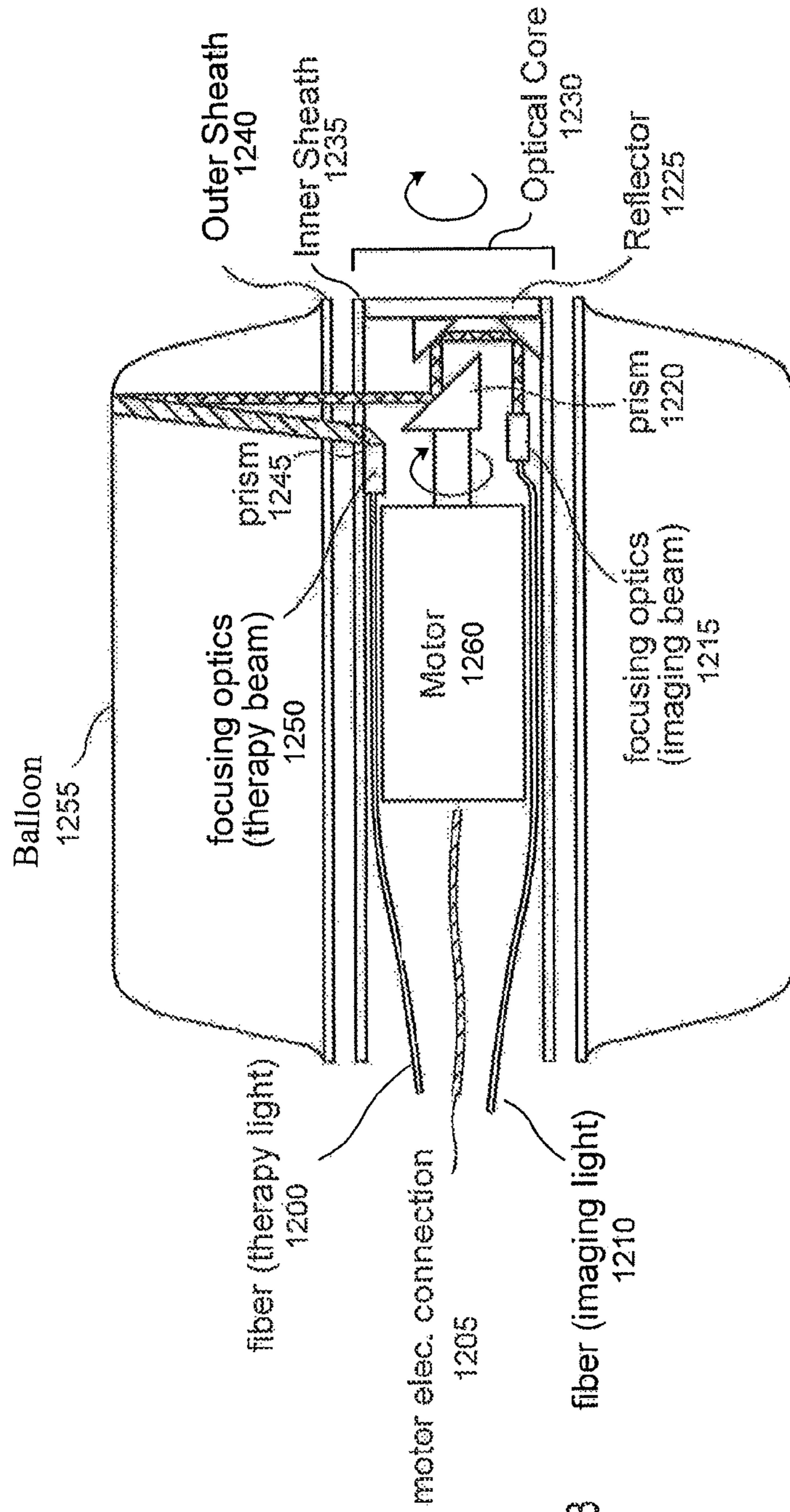

FIG. 23

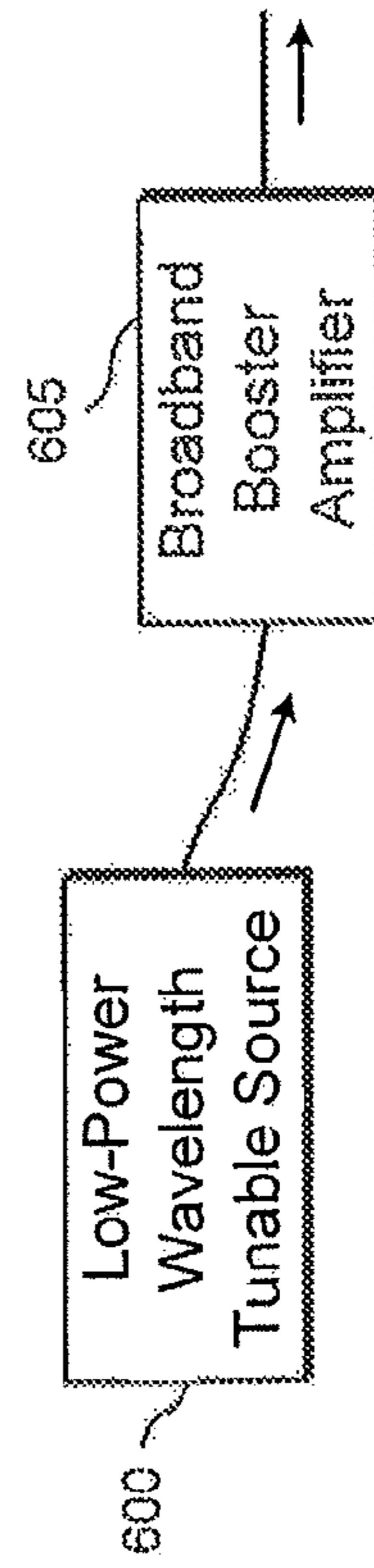

FIG. 24

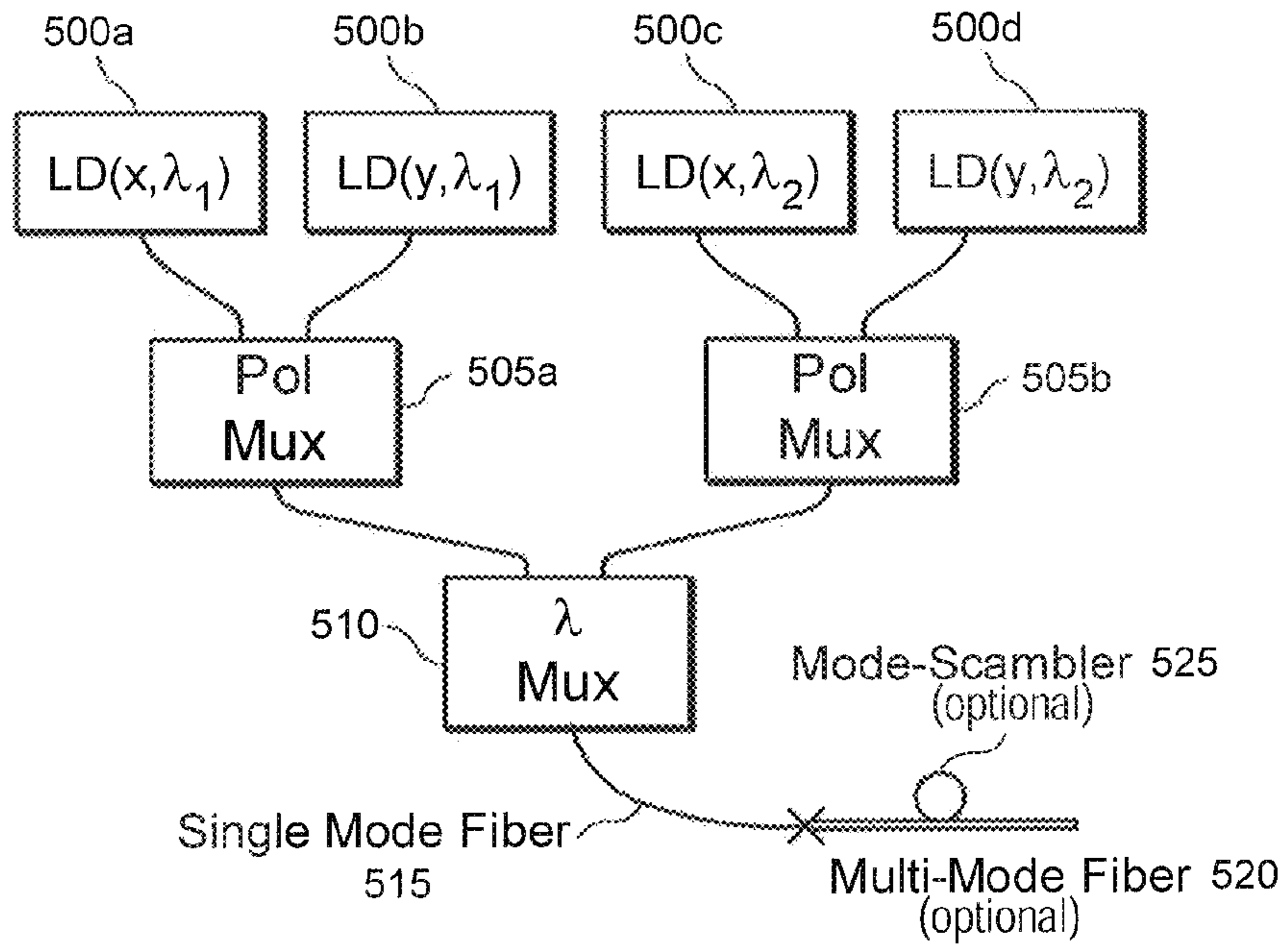

FIG. 25

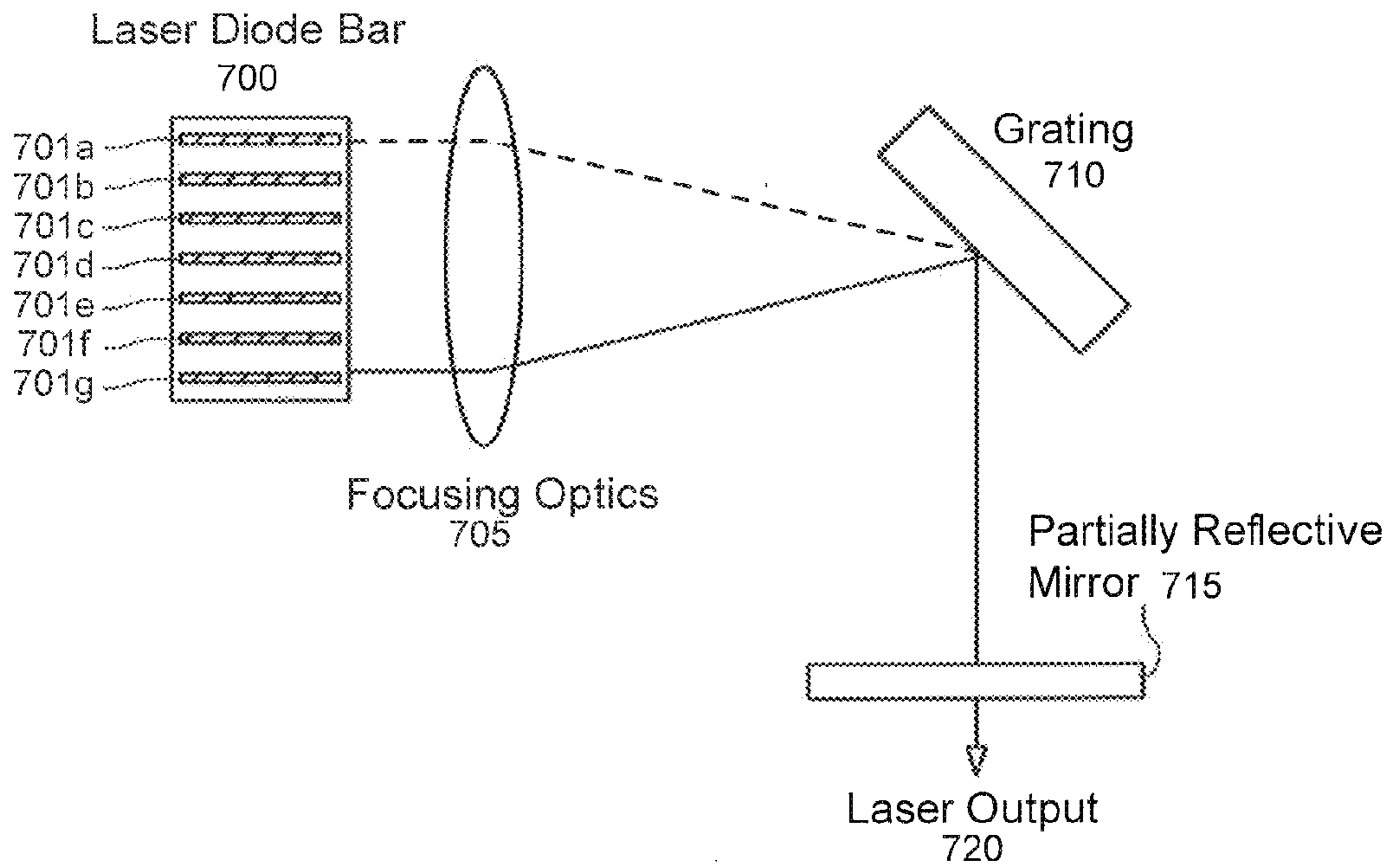

FIG. 26

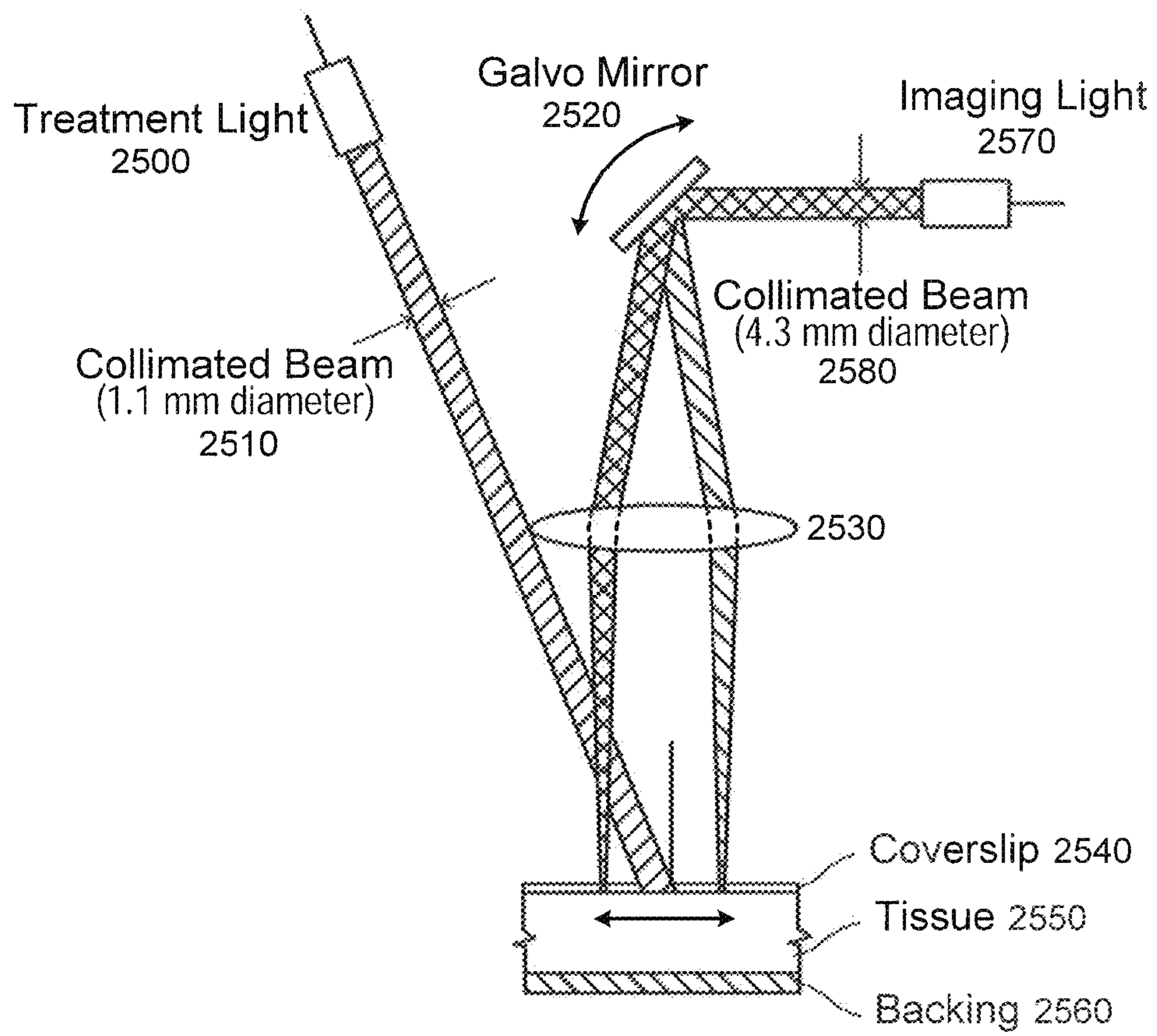

FIG. 27

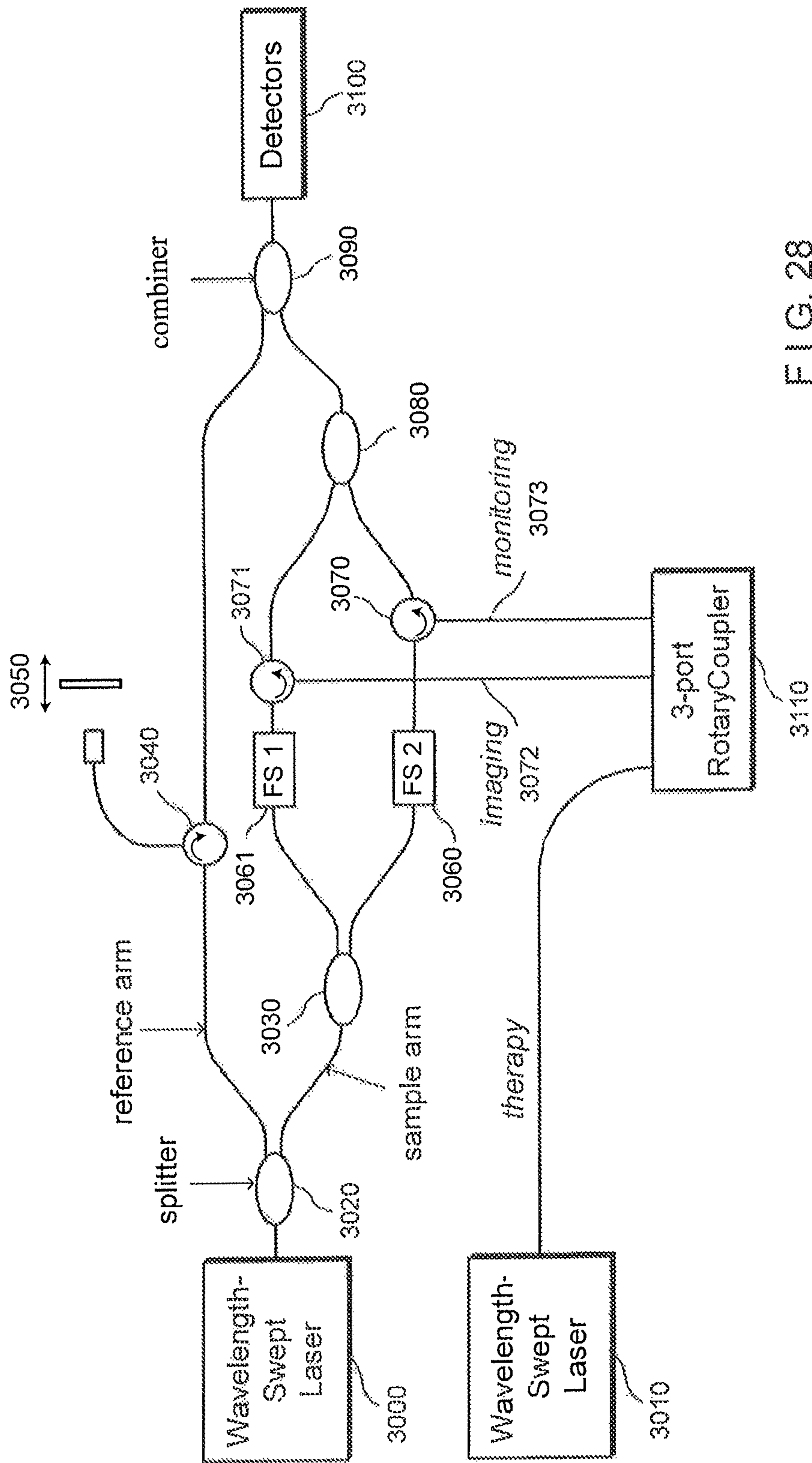
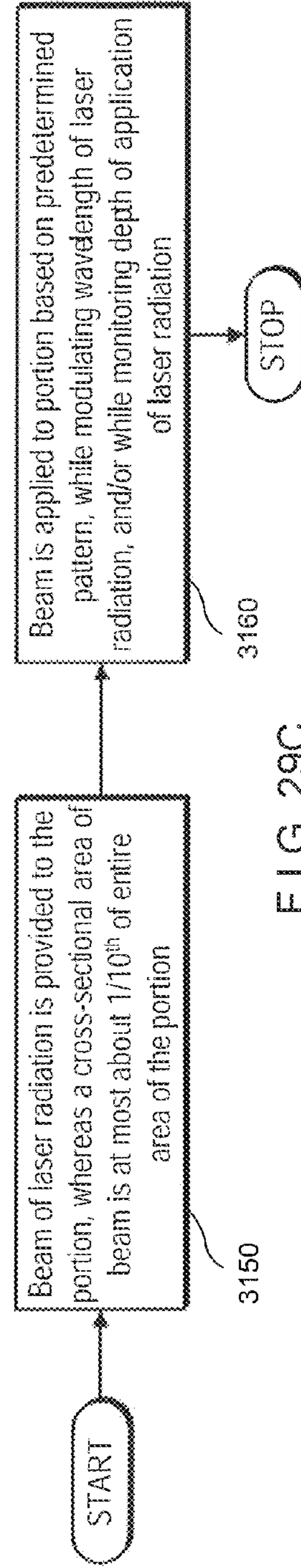
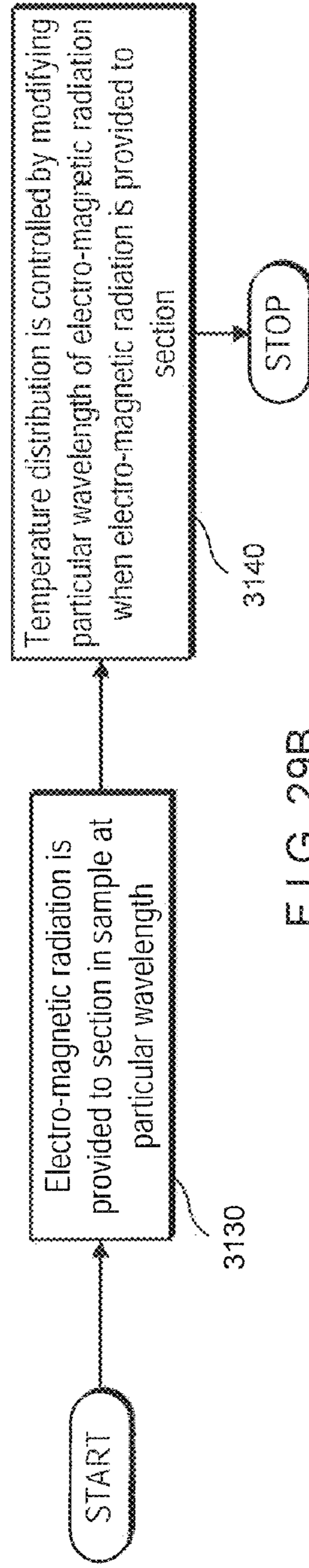
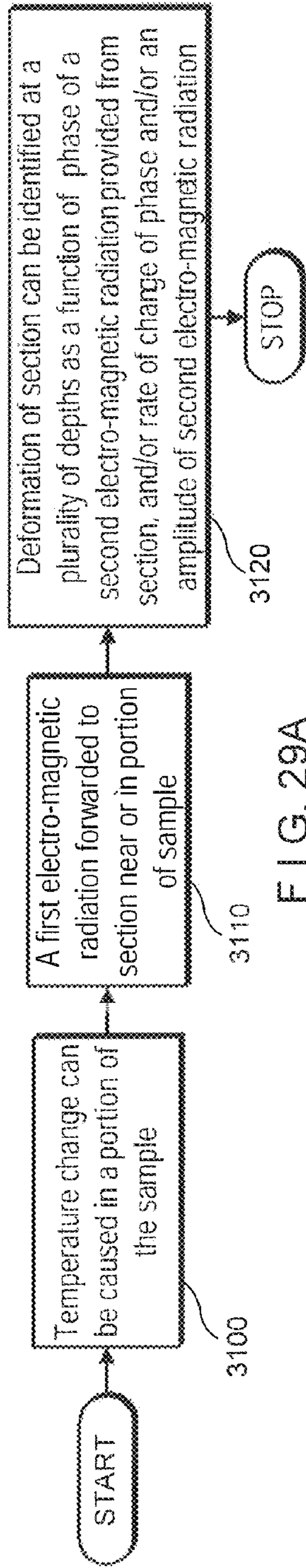

FIG. 28



**APPARATUS FOR APPLYING A PLURALITY
OF ELECTRO-MAGNETIC RADIATIONS TO
A SAMPLE**

CROSS-REFERENCE TO RELATED
APPLICATION(S)

This application is based upon and claims the benefit of priority from U.S. Patent Application Ser. No. 60/764,622, filed Feb. 1, 2006 and U.S. patent Application Ser. No. 60/810,868, filed Jun. 1, 2006, the entire disclosures of which are incorporated herein by reference.

STATEMENT REGARDING FEDERALLY
SPONSORED RESEARCH

The invention was made with the U.S. Government support under Contract No. 17-02-2-0006 awarded by the US Department of the Army Cooperative Agreement (DAMD). Thus, the U.S. Government has certain rights in the invention.

FIELD OF THE INVENTION

The present invention relates to apparatus for controlling at least one of at least two sections of at least one fiber, and in particular to the apparatus which can include a plurality of channels.

BACKGROUND OF THE INVENTION

A use of lasers for ablating or thermally destroying diseased tissue is known and at time preferred, primarily due to the potential for precise local effect with minimal collateral damage. In practice, however, laser therapy has been less than perfect for use in certain clinical applications, such as the treatment of early epithelial cancers and their precursors. One of the problems with laser therapy for these applications has been the inability to accurately control and guide the treatment depth, resulting in either disease recurrence due to incomplete therapy or complications associated with overly aggressive treatment.

Epithelial Cancer: Diagnosis and Treatment

Methods and techniques for identifying and treating cancer at an early stage have been widely pursued as offering the potential to dramatically decrease the morbidity and mortality associated with metastasis. Since epithelial cancers and precursor lesions are frequently focal and can be distributed heterogeneously across a wide field, a sensitive diagnosis is extremely demanding. A diagnosis should be rendered on the size scale of a single cell in a field comprising possibly more than a billion cells.

Epithelial cancer also presents challenges for therapy. Since they are superficial, access to epithelial lesions can frequently be obtained through the use of minimally invasive catheters or endoscope. The therapeutic challenge, however, is in comprehensively killing, resecting or ablating the entire lesion without damage to underlying or adjacent tissues. This is particularly challenging since the depth of disease and even the thickness of normal epithelial layers can vary substantially. Additionally, epithelial tissues are highly compliant and therapeutic instrumentation can result in significant compression. As a result, therapies designed to affect tissue to a fixed depth risk either under-treatment resulting in recurrence, or over-treatment that can lead to significant complications.

Barrett's Esophagus

The importance of Barrett's esophagus (BE) is based primarily on the prevalence of this disease, the rapid increase in its incidence, and the dismal prognosis for patients with high-grade dysplasia and adenocarcinoma as described in publication 1 identified below. The current consensus (as described in publications 2 and 3 identified below) holds that comprehensive destruction of BE in a controlled fashion, along with anti-reflux treatment, results in squamous regrowth and that continued reflux control prevents the return of BE. The challenge is in achieving comprehensive removal of the pathologic mucosa, while preserving the underlying tissues of the esophageal wall. Treatment that is incomplete can result in a squamous overgrowth that masks underlying pathology. Overly aggressive therapy can result in stricture or perforation of the esophageal wall. Provided below is the information relating to screening and therapy of BE.

Screening

Several approaches for esophageal screening in the management of BE have been investigated. Brush cytology (as described in publications 4 and 5 identified below) and the use of biological markers, such as the deletion and/or mutation of the 17p (p53) gene, (as described in publications 6 and 7 identified below) can be used independently of endoscopy but cannot provide spatial mapping of disease. High magnification video endoscopy (as described in publication 8 identified below), fluorescence spectroscopy (as described in publications 9 identified below), and light-scattering spectroscopy (as described in publications 10 identified below) each show promise for point diagnoses, but provide insufficient information regarding subsurface microstructure and have not been demonstrated for wide-field screening. High-resolution endoscopic ultrasound and chromoendoscopy (as described in publications 11 and 12 identified below, respectively) can both be applied to a wide field, but have suffered from low sensitivity and specificity.

Optical coherence tomography (OCT) system, methods and techniques (as described in publications 13 and 14 identified below) has been developed. Certain accurate OCT diagnostic criteria have been developed for specialized intestinal metaplasia, dysplasia and adenocarcinoma, as described in International Patent Application PCT/US2004/029148, filed Sep. 8, 2004, U.S. patent application Ser. No. 10/501,276, filed Jul. 9, 2004, and publications 15-17 identified below. For example, advances in OCT technology have occurred demonstrating that the acquisition of an OCT signal in the wavelength domain (as opposed to the time domain) can provide orders of magnitude improvement in imaging speed while maintaining excellent image quality, as described in publications 18-20 identified below. One such exemplary second-generation imaging technology has been developed, e.g., optical frequency domain imaging (OFDI), as described in U.S. patent application Ser. No. 11/266,779, filed Nov. 2, 2005 and publication 21 identified below. With OFDI methods, techniques and systems, high-resolution ranging can be conducted in a tissue by detecting spectrally-resolved interference between the tissue sample and a reference while the source wavelength is tuned. (See, e.g., publication 22 identified below). Currently, OFDI methods, techniques and systems may be capable of capturing (e.g., 10 μm) 3 voxels at rates of approximately 40 million per second and the imaging speeds may likely be more than double in the near future, as provided in publication 23 identified below. Additionally, phase-sensitive OFDI methods, techniques and systems has been used for imaging flow, as provided in publication 24 identified below.

Controllable Therapy

Certain endoluminal approaches have been evaluated for the treatment of SIM (with and without dysplasia), including photodynamic therapy (PDT) (as provided in reference 25 identified below), laser (532 nm and 1064 nm) (as provided in reference 26 identified below), multipolar electrocoagulation (as provided in reference 27 identified below), argon plasma coagulation (as provided in reference 28 identified below), endoscopic mucosal resection (as provided in reference 29 identified below), radiofrequency ablation (as provided in reference 30 identified below) and cryoablation (as provided in reference 31 identified below) using liquid nitrogen. Although each of these techniques appear to be successful, most studies describe non-uniform therapy that can potentially result in persistent SIM or excessively deep ablation, resulting in stricture or perforation. In a study of over 100 patients, PDT may result in a stricture rate of 30% for single treatments and 50% for more than one treatment (as provided in reference 32 identified below). An exemplary reason for failure is not entirely clear but possible contributing causes include the operator-dependent nature of many of these hand-held, hand-aimed devices, the large surface area that requires treatment and the inherent preference for a physician-determined visual end point for the treatment (as provided in references 3 and 30 identified below). Additionally, a high variability may exist in the thickness of mucosal layers within and between patients and have directly observed significant compression of the soft tissues of the esophagus. The prior therapeutic approaches, however, do not account for the variability of layer thickness or compressibility of the esophageal wall.

Accordingly, there is a need to overcome the deficiencies described herein above.

OBJECTS AND SUMMARY OF THE INVENTION

To address and/or overcome the above-described problems and/or deficiencies as well as other deficiencies, exemplary embodiments of apparatus for controlling at least one of at least two sections of at least one fiber, and which includes a plurality of channels.

Such deficiencies can be addressed using the exemplary embodiments of the present invention. In one exemplary embodiment of the present invention, an apparatus for applying a plurality of electro-magnetic radiations to a sample can be provided. The apparatus can include an arrangement which has a specific portion with a plurality of channels. One of channels can facilitate a first radiation of the radiations to be forwarded to the sample that is within an anatomical structure, and another one of the channels can facilitate a second radiation of the radiations to be forwarded to the sample. The first radiation may have a first wavelength band, and the second radiation may have a second wavelength band. The first wavelength band may be substantially different from the second wavelength band.

For example, the channels can include at least one optical fiber. The optical fiber may be double-cladded and/or dual-cored. A further arrangement can be provided which can have a single channel which is in an optical communication with at least two of the channels of the specific portion. The further arrangement may be a fused fiber wavelength division multiplexer, a thin film wavelength division multiplexer, a grating and/or a dichroic mirror.

According to another exemplary embodiment, the first radiation can be adapted to be delivered to a first area of the sample, and the second radiation may be capable of being

delivered to a second area of the sample. The first area may be substantially enclosed by the second area. A further one of channels can facilitate a third radiation of the radiations to be forwarded to the sample. The third radiation may be delivered to a third area of the sample that is substantially separate from the first and second areas. A further arrangement having a single channel can be provided which is in an optical communication with at least two particular channels of the channels of the specific portion. A path from the single channel to the sample via one of the particular channels may have a first optical distance, and a path from the single channel to the sample via another one of the particular channels may have a second optical distance. The first optical distance may be different from the second optical distance by at least about 0.5 mm and/or at most about 8 mm.

According to yet another exemplary embodiment of the present invention, each of the channels can facilitate at least one particular radiation of the radiations to be forwarded to the sample that is within an anatomical structure of the sample, the radiations being delivered to different areas of the sample. Centers of every one of the areas may be provided substantially along a line. The line can be provided substantially parallel to a scanning direction of the radiations.

These and other objects, features and advantages of the present invention will become apparent upon reading the following detailed description of embodiments of the invention, when taken in conjunction with the appended claims.

BRIEF DESCRIPTION OF THE DRAWINGS

Further objects, features and advantages of the present invention will become apparent from the following detailed description taken in conjunction with the accompanying figures showing illustrative embodiments of the present invention, in which:

FIG. 1 is a schematic diagram of an OFDI balloon catheter in accordance with an exemplary embodiment of the present invention;

FIG. 2A is an exemplary image of a perspective view of a swine esophagus obtained using the OFDI balloon catheter in accordance with an exemplary embodiment of the present invention;

FIG. 2B is an exemplary image of a top view of the swine esophagus of FIG. 2A;

FIG. 2C is an exemplary image of a side view of a wall of the swine esophagus of FIG. 2A;

FIG. 3 is an exemplary OFDI image acquired in a human subject using a BE technique in accordance with an exemplary embodiment of the present invention;

FIG. 4 is a schematic diagram of exemplary arrangement and usage thereof for treating and monitoring tissue in accordance with an exemplary embodiment of the present invention;

FIG. 5 is a set of multiple exemplary m-mode OFDI phase images obtained using the exemplary arrangement of FIG. 4 together with a corresponding histology;

FIGS. 6A-6D are exemplary images associated with the OFDI data acquired for a translating sample in accordance with the exemplary embodiment of the present invention;

FIG. 7A is an exemplary pre-laser treatment OFDI image obtained using the exemplary embodiment of the present invention;

FIG. 7B is an exemplary pre-laser treatment birefringence image obtained using the exemplary embodiment of the present invention;

5

FIG. 7C is an exemplary post-laser treatment OFDI image obtained using the exemplary embodiment of the present invention;

FIG. 7D is an exemplary post-laser treatment birefringence image obtained using the exemplary embodiment of the present invention;

FIG. 8 is an image of an exemplary vascular map extracted from a comprehensive dataset obtained from porcine esophagus in-vivo which can be obtained using the exemplary embodiment of the present invention;

FIG. 9 is an exemplary in-vivo Doppler flow image of a porcine esophagus obtained using the exemplary embodiment of the present invention;

FIG. 10 is a plot of water absorption coefficient and corresponding penetration depth as a function of wavelength obtained using the exemplary embodiment of the present invention;

FIG. 11 is a schematic diagram of a two beam catheter probe in accordance with another exemplary embodiment of the present invention;

FIG. 12 is schematic side and front illustrations of a three beam catheter probe in accordance with yet another exemplary embodiment of the present invention;

FIG. 13 is a perspective view of a watch-spring multichannel optical rotary junction in accordance with an exemplary embodiment of the present invention;

FIG. 14 is a conceptual rendering of an image which can provide feedback to a user obtained using an exemplary embodiment of the present invention;

FIG. 15 is a block diagram of a sample arm of an OFDI system incorporating an optical switch in accordance with a further exemplary embodiment of the present invention;

FIG. 16 is a block diagram of the sample arm of the OFDI system incorporating an optical splitter in accordance with a still further exemplary embodiment of the present invention;

FIG. 17 is a block diagram of the sample arm of the OFDI system incorporating a single wavelength-division multiplexer in accordance with yet further exemplary embodiment of the present invention;

FIG. 18 is a block diagram of the sample arm of the OFDI system incorporating a cladding mode coupler and a dual-clad fiber in accordance with still another exemplary embodiment of the present invention;

FIG. 19 is a block diagram of a three-port rotary coupler and catheter in accordance with an exemplary embodiment of the present invention;

FIG. 20 is a block diagram of a single-fiber rotary coupler with subsequent demultiplexing of the therapy light and capable of splitting of imaging light in accordance with another exemplary embodiment of the present invention;

FIG. 21 is a schematic diagram and usage of a two-beam in-line catheter probe in accordance with an exemplary embodiment of the present invention;

FIG. 22 are front and side illustrations of a three-beam catheter probe and balloon catheter in accordance with an exemplary embodiment of the present invention;

FIG. 23 is a side view of a micro-motor-based arrangement capable of generating a slowly rotatable therapy beam and fast scanning imaging beam in accordance with an exemplary embodiment of the present invention;

FIG. 24 is a block diagram of a therapy source incorporating a low power tunable source followed by a broadband booster amplifier in accordance with an exemplary embodiment of the present invention;

6

FIG. 25 is a block diagram of a therapy source incorporating multiple laser diodes (LDs) at difference wavelengths and polarizations in accordance with another exemplary embodiment of the present invention;

FIG. 26 is an illustration of a wavelength-tunable therapy source incorporating a laser diode bar and results generated thereby in accordance with an exemplary embodiment of the present invention;

FIG. 27 is a side view of another exemplary embodiment of a system which includes a galvanometric scanner which can allow the OFDI beam to be repetitively scanned across the surface of the tissue, and usage thereof;

FIG. 28 is a schematic diagram of a further exemplary embodiment of the OFDI system according to the present invention which can be used to detect both the imaging and monitoring signals via acousto-optic frequency shifters;

FIG. 29A is a flow diagram of an exemplary embodiment of a method for obtaining information associated with at least one portion of a sample according to the present invention;

FIG. 29B is a flow diagram of another exemplary embodiment of the method for controlling a temperature distribution in the sample according to the present invention; and

FIG. 29C is a flow diagram of yet another exemplary embodiment of the method for applying a laser radiation to at least one portion of a biological structure according to the present invention.

Throughout the figures, the same reference numerals and characters, unless otherwise stated, are used to denote like features, elements, components or portions of the illustrated embodiments. Moreover, while the subject invention will now be described in detail with reference to the figures, it is done so in connection with the illustrative embodiments. It is intended that changes and modifications can be made to the described embodiments without departing from the true scope and spirit of the subject invention as defined by the appended claims.

DETAILED DESCRIPTION OF EXEMPLARY EMBODIMENTS

An exemplary embodiment of the system and method according to the present invention for controlling and localizing therapy can be based on a thermal excitation delivered by a conventional, spatially scanned laser beam. For example, in the absence of photochemical or phase transition processes, the laser energy absorbed by tissue can be substantially or entirely converted to a temperature rise, as described in publication 33 identified below. For exposure durations greater than approximately 10 ms, temperatures in excess of 60-70° C. generally can lead to irreversible protein denaturation and cell death irrespective of duration, as described in publication 34 identified below. When the energy is absorbed, it can be subject to a spatial redistribution by a thermal diffusion. In 1983, as described in publication 35 identified below, an exemplary concept was described which provided that spatially confined microsurgical effects (selective photothermolysis) can be achieved by the use of laser exposures that are shorter than the characteristic thermal diffusion time of the heated volume. For a relatively large (>1 mm) diameter laser beam and laser wavelengths in the vicinity of 1450 nm, this characteristic diffusion time for biological tissues may be on the order of 1 second. Under these conditions, the temperature increase can be determined by the laser power density, P_a , the absorption coefficient, μ_a , and the duration of exposure t (as described in publications 33 and 34 identified below) as follows:

$$\Delta T(t, r, z) \approx \frac{P_d t \mu_a}{\rho c} \exp\left(-\mu_a z - \frac{2r^2}{W^2}\right) \quad \text{Eq. 1}$$

where ρ is the tissue density, c the heat capacity, and r the radial distance from the center of a Gaussian laser beam of $1/e^2$ radius, W . Although this approximation neglects scattering of the laser light as it propagates into the tissue, models that explicitly include scattering (as described in publication 36 identified below) indicate less than 10% deviation from Eq. 1 under the stated conditions.

Since the absorption coefficient is wavelength-dependent, Eq. 1 indicates that laser parameters P_d , t , and wavelength can be used to control the depth of thermal injury and to minimize collateral damage to underlying tissues. Operating in the visible portion of the spectrum is challenging since absorption is governed by a wide range of chromophores whose concentration is highly variable across different tissues and pathologic conditions. By comparison, the absorption spectrum of biological tissues near $1.45 \mu\text{m}$ may be dominated by water, and can therefore be roughly constant across a range of tissues. Additionally, by tuning over a modest wavelength range, from 1375 nm to 1430 nm for example, absorption lengths can be selected that range from over 2 mm to $300 \mu\text{m}$. This exemplary range is well matched to the depths characteristic of epithelial lesions.

Exemplary Monitoring

Several approaches have been investigated for monitoring laser therapy, including the analysis of the acoustic transients generated during ablation (as described in publication 37 identified below), changes in tissue reflectivity (as described in publications 38 and 39 identified below), fluorescence spectroscopy for discrimination between plaque and vessel wall (as described in publication 40 identified below), plasma spectroscopy to distinguish between bone and nerve tissue (as described in publication 41 identified below), and analysis of the cavitation bubble dynamics at the tip of a laser optical probe for controlled sclera perforation in glaucoma surgery (as described in publication 42 identified below). With the exception of the procedures that are based on a reflectivity described in publications 38 and 39, in each of such methods, the monitoring signal arose only after the zone of thermal injury has transitioned across a boundary of the specific tissue types. None could determine the depth of thermal injury or the spatial relationship of the damaged tissue to adjacent viable tissue. Certain degree of spatial resolution has been achieved by monitoring the portion of laser light that is not absorbed by the tissue. By inserting an optical fiber through a needle, this light can be collected from different perspectives surrounding the heated volume and temperature-dependent scattering changes can be measured (as described in publication 43 identified below). A more direct approach, high-resolution in situ imaging, has also been demonstrated for visualizing scattering changes and the physical removal of tissue resulting from ablative laser irradiation (as described in publication 44 identified below).

Exemplary embodiments of monitoring systems, methods and techniques according to the present invention may utilize information regarding well-known tissue responses to a thermal injury. These exemplary responses can include, but not limited to, microscopic deformation (as described in publication 33 identified below) and changes in scattering (as described in publications 36, 38 and 45 identified below), birefringence (as described in publication 46 identified below), and blood flow (as described in publication 47 identified below) that can result from laser heating and that can be

observed over a range of temperatures beginning as low as 45°C . One exemplary aspect of an exemplary embodiment of the method and technique according to the present invention is that these thermal responses can be detected with high spatial resolution and presented in a cross-sectional image format along with the microscopic tissue structure.

Exemplary Strategies for Conformal Laser Therapy

According to an exemplary embodiment of the present invention, a system, arrangement and method can be provided that are capable of screening and delivering precisely guided laser therapy. Since the characteristic length-scales preferably usable for comprehensive screening and comprehensive therapy are likely distinct, it is possible to separately perform these objectives. For example, the screening (e.g., possibly performed as a first step) may utilize comprehensive imaging technique(s) with a resolution on the cellular size-scale. This exemplary procedure can be used to identify regions for subsequent therapy. After the performance of the screening procedure, the endoscopic probe can be directed back to the specified regions, and therapy may be performed under real-time guidance so that all disease is treated and collateral damage is minimized. This exemplary result can improve the management of patients with Barrett's esophagus by, e.g., increasing the effectiveness of therapy while decreasing the risk of complications.

Although described in conjunction with a treatment of epithelial cancers, the exemplary embodiments of the system, techniques and methods according to the present invention can be applicable to any application of laser treatment including but not limited to, for example, applications in dermatology. Some relevant epithelial cancers and precancerous lesions addressed by the exemplary embodiments of the present invention can include, but not limited to, the larynx, cervix and ovaries, bladder, oral cavity and lung. In addition, the exemplary embodiments of the present invention can be applicable to the areas of monitoring photodynamic therapy, radiofrequency ablation, and cryotherapy to provide control over depth and spatial extent of therapy.

Exemplary Wide-Field Screening

In order to perform an effective screening procedure, it is preferable to conduct a comprehensive examination of large surface areas and the application of accurate diagnostic criteria in order to identify specific regions of pathology. Various OCT diagnostic criteria has been developed and verified for specialized intestinal metaplasia, dysplasia and adenocarcinoma, as describe in publications 15-17 identified below. For example, across 288 biopsies obtained from 121 patients, a sensitivity and specificity for diagnosing SIM (versus all other upper GI tract tissues) has been determined of about 97% and 92%, respectively, as described in publication 16 identified below. Until recently, however, the exemplary OCT technique was too slow to image large mucosal surface areas. As discussed herein below, advances have been made that may overcome this timing issue, and provide a preliminary demonstration of comprehensive esophageal imaging in vivo.

Optical Frequency-Domain Imaging (OFDI)

As described above, publication 21 identified below describes the development of the OFDI technique as an alternative to the use of the OCT techniques. Although the light source (as discussed in publication 22 and 23 identified below) and the detection principles of OFDI are useful, the contrast, resolution and cross-sectional image presentation are approximately equivalent or similar to those provided by OCT. One of the advantages of OFDI is that OFDI has a higher detection sensitivity, thus enabling a significant increase in the image acquisition speed, without compromising image quality. The system used for these preliminary

studies was designed specifically for endoscopic imaging and provides an acquisition rate of 10,000 depth-scans (A-lines) per second, an axial resolution of 8 μm in tissue, and a ranging depth of 3.5 mm, as described in publication 24 identified below. The imaging speed of this exemplary system is limited solely by the rate at which data can be transferred across the computer's bus and stored to a hard drive.

Exemplary Balloon Catheter

For comprehensive esophageal imaging, an exemplary embodiment of an OFDI catheter may be provided in accordance with the present invention that can be centered within the esophageal lumen using a balloon sheath shown in FIG. 1. The exemplary catheter may include of a probe scanner **2000** which can rotate, and may pull back an inner optical core **2010**. The inner core **2010** can be enclosed within a transparent sheath **2020**. At the distal end of the catheter, the balloon **2040** which, when inflated, may center the imaging optics. The imaging beam **2030** can be focused onto the esophageal surface **2050**. This imaging beam **2030** may be scanned to achieve comprehensive imaging. The balloon **2040** can have an inflated diameter of 1.8 cm, and may allow for a longitudinal imaging over a length of 4.5 cm without repositioning. The optical core **2010** of the catheter can include an optical fiber, a spacer for expansion of the optical beam, a gradient index lens for focusing, and a right-angle prism for directing the beam perpendicularly to the longitudinal axis of the catheter. A miniature cylindrical lens was fabricated in-house and placed on the second surface of the prism. This lens compensated for astigmatism induced by the plastic sheaths and resulted in a diffraction-limited beam (30 μm diameter) on the tissue surface. In use, the exemplary catheter may be rotated at rate of about 4 revolutions per second, allowing the acquisition of 2500 axial scans per circular cross-section. This exemplary OFDI system can record an encoder signal to precisely track the rotation and pull-back of the catheter. This information is used in reconstructing the 3-dimensional data set.

Preliminary Porcine Esophageal Imaging

The esophageal imaging techniques can be performed in two ~50 kg swine. Although the complete 20 GB data set may likely not be represented in discrete figures, the information content is shown by FIGS. 2A-2C. For example, in a perspective view of FIG. 2A, an image **2100** provides a 3D rendering of the entire imaged esophagus. In a front view of FIG. 2B, an image **2110** illustrates a single transverse cross section of the imaged esophagus. In FIG. 2C, image **2120** shows a zoomed cross sectional image of at least one portion of the esophagus. A sampling with a resolution of 10 μm \times 20 μm \times 30 μm (r, θ ,z) can yield a comprehensive microscopic data set that can be displayed volumetrically as the image **2100** of FIG. 2A for mapping and orientation, or in high-resolution cross-sectional images in which the entire esophageal wall can be visualized as the image **2110** in FIG. 2B. An expanded view of the image **2120** of FIG. 2C depicts the architectural structure of the mucosal layers.

Preliminary Human Esophageal Imaging

An exemplary single rotational image **2150** is shown in FIG. 3. Hallmark features of SIM (disorganized epithelial architecture with irregular surface; presence of large epithelial glands) of a patient are shown therein. This patient had a prior diagnosis of BE, and imaging was performed prior to PDT.

These preliminary studies demonstrate that a) comprehensive OFDI microscopic imaging in vivo is feasible, b) the architectural structure of the entire esophageal wall can be

visualized, and c) features important to the diagnosis of SIM in human subjects can be detected using the balloon centering probe.

Monitoring Laser Thermal Injury

In response to heating, tissue proteins and collagen can denature, giving rise to microscopic deformation (described in publications 33 identified below), increased in scattering (described in publications 36, 38 and 45 identified below), reduced birefringence (described in publication 46 identified below), and reduced blood flow (described in publication 47 identified below). The description below provides the methods for monitoring these changes using exemplary OFDI in accordance with the exemplary embodiments of the present invention. In the exemplary demonstration of each, freshly obtained porcine esophagus samples and duodenum samples (as a proxy for SIM) were mounted with a microscope cover glass on the epithelial surface so that the approximate pressure and thermal conductivity of the balloon catheter could be simulated.

An exemplary embodiment of an apparatus for collecting OFDI signals during a laser irradiation and use thereof according to the present invention is shown in FIG. 4. For example, the treatment light is delivered through a collimator **2200**. The imaging light is delivered through a second collimator **2220**. The treatment beam **2210** and imaging beam **2230** overlap when reaching the tissue **2270** which is covered with a think glass cover slip **2260** and resting on a backing **2280**. The tissue is translated by a motorized translation stage **2290**. The imaging beam is focused by a lens **2250**. The top-down image depicting beam overlap **2250** is provided. For a thermal excitation, a collimated, high-power Gaussian laser beam (e.g., diameter=1.1 mm; wavelength=1450 nm; power=400 mW) can be used. The OFDI sampling beam can be focused at the tissue surface to, e.g., a $1/e^2$ intensity diameter of 23 μm and aligned so that it overlapped with the laser spot as shown in FIG. 4. During the data collection, the samples may be held at a fixed location and/or translated using a motorized stage.

Exemplary Microscopic Deformation

As laser energy is deposited in tissue, the resulting temperature increase can denature proteins and collagen. These changes can be manifested by microscopic deformation that can be measured using phase-sensitive OFDI. The following data demonstrates this capability.

Fixed Spot—

For such exemplary experiment, the samples were held at a fixed location. OFDI depth-scans were acquired continuously at a rate of about 10 kHz while the 1450 nm laser was switched on, held at a constant power of 400 mW for a predetermined duration, and switched off. Representative data for three different laser exposure durations is shown in the graphs of FIG. 5 as "M-mode" images where the vertical axis **2300a**, **2300b**, **2300c** represents depth within the tissue, the horizontal axis **2310a**, **2310b**, **2310c** denotes time and the magnitude of the measured phase-shift is represented using a color lookup table **2320** (red=positive phase-shift; blue=negative). A red horizontal line **2330a**, **2330b**, **2330c**, at the top of each phase-shift image denotes the interval over which the laser was on. Upon initial laser exposure, a superficial region of positive phase-shift overlying a lower region of negative shift has been observed. As the laser irradiation continued, the depth at which the phase transitioned from positive to negative became progressively deeper and the magnitude of the overlying phase-shift decreased. No measurable phase-shift was detected after the laser was switched off. A protein denaturation gives rise to local microscopic structural changes and a nidus of local deformation that is

detected as a phase-shift in the interferometric signal. As the laser exposure continues, the zone of active denaturation propagates in depth with overlying tissues becoming completely denatured. The depth at which the direction of the phase-shift reverses identifies the focal center of active denaturation.

To verify these results, histological sections were obtained following laser exposure and nitro-blue tetrazolium chloride (NBTC) staining was used to assess the extent of laser damage. NBTC stains positive for lactate dehydrogenase (LDH), which is a thermolabile enzyme; loss of LDH activity ensues rapidly upon heat induced cell damage and is correlated with cell lethality (as described in publications 48 and 49 identified below). Therefore, the depth of the border between unstained and stained tissue have been selected as the depth of laser damage. Corresponding phase-shift data and histology are shown in 2340a, 2340b, 2340c. The preliminary findings suggest that the border between thermally denatured tissue and viable tissue corresponds with the inflection point of the phase-shift measured with OFDI. Quantitatively, the depth-derivative of the phase-shift has been determined for each A-line and defined the depth of injury as the point of maximum negative value of the derivative. The depths determined in this way are provided in FIG. 5 as vertical lines adjacent to each M-mode image and show a good correspondence with histomorphometry.

Translating Spot—

Laser treatment of large epithelial surface areas can be facilitated by adding a therapeutic laser beam to the existing OFDI catheter so that the laser and OFDI beams are simultaneously scanned. The preliminary imaging studies demonstrated comprehensive esophageal imaging with an OFDI beam size of 30 μm . Obtaining a precise alignment of >1 mm diameter laser beam on successive rotational scans should therefore be obtainable. To simulate the monitoring while scanning, the computer-controlled translation stage 2290 (see FIG. 4) can be controlled to repetitively toggle the sample velocity from 1.8 mm/s to 0.9 mm/s.

An OFDI intensity image 2400 acquired with no laser irradiation is shown in FIG. 6A. For the images 2410, 2420 and 2430 shown in FIGS. 6B, 6C, and 6D, respectively, the 1450 nm laser power was about 400 mW. The translation of the samples during the exposure resulted in a line of laser damage across the surface of the sample. Since the thermal energy deposition can be proportional to the exposure time (see Eq. 1), the depth of laser damage can vary along the line according to the inverse of the translation velocity. Histology sections, obtained from regions of fast and slow translation and with an orientation perpendicular to the line, indicated laser injury depths of 0.41 mm and 0.69 mm respectively. The phase-shift data corresponding to the image 2410 of FIG. 6B is illustrated as the image 2420 in FIG. 6C. In a substantial agreement with the histomorphometric measurements, the depth of the damage determined by the phase-shift data (max negative derivative) can be 0.40 mm and 0.67 mm in the regions of fast and slow velocity, respectively.

Speckle Decorrelation

Speckle is a phenomenon that is commonly observed when imaging with coherent illumination and manifests as a grainy pattern of high- and low-intensity that does not appear to correlate with the macroscopic structure. In tissue, speckle generally arises from the interference between photons that have traversed different paths during propagation within the sample. If the scatterers within the tissue are moving, even on a microscopic scale, the speckle pattern is likely seen to rapidly fluctuate. The measurements of the time-evolution of the speckle pattern can therefore provide insight into micro-

scopic motion within the sample. This exemplary technique has been provided for investigating biomechanical properties (as described in publication 50 identified below), and thermal excitation (as described in publication 51 identified below), in biological tissues. The extension of these concepts to the depth-resolved monitoring of laser tissue interactions with OFDI has been reviewed.

Viewing the OFDI images of the tissue during laser exposure provides an indication of the potential of this exemplary technique. With no laser exposure, the speckle pattern observed in OFDI remained constant over the depth and transverse extent of the image. Under laser irradiation, the speckle pattern was observed to rapidly fluctuate in the local region of the laser beam. In slow-motion viewing, we observed that the speckle fluctuations began near the tissue surface and propagated downward in time. To quantify these observations, the rate of speckle decorrelation for each depth point of the image 2410 shown in FIG. 6B has been determined. In particular, the depth-dependent width of the temporal autocorrelation function of the OFDI intensity signal has been determined. Speckle decorrelation images were then generated by displaying the autocorrelation width using a grayscale lookup table. The image 2430 of FIG. 6D is the speckle decorrelation image corresponding to the images 2410 and 2420 of FIGS. 6B and 6C, respectively. The depth of the peak decorrelation rate (black band, denoted by arrows in FIG. 6D) can be observed to vary in correspondence with the translational rate of the sample and the depth of laser damage indicated in histology. The consistency of this finding across samples of esophagus and duodenum confirm that the depth of peak decorrelation rate is a quantifiable metric for determining the depth of laser injury.

Birefringence

As light propagates within materials, its polarization state can become altered if the index of refraction is non-isotropic. This effect is known as birefringence. Many tissues, especially muscle and collagen, exhibit strong birefringence which is lost upon thermal heating and denaturation (as described in publication 46). Polarization-sensitive OCT (PS-OCT) techniques, methods and systems have been described for quantifying burn depth through measurements of birefringence loss. (See publications 52 and 53 identified below). In PS-OCT, two detector channels can be configured to receive orthogonal polarization states of the light returning from the sample. Birefringent samples induce a depth-dependent rotation of the polarization state, resulting in a variation in the percentage of the sample light detected in each channel. If the ratio of the two channels is displayed as a grayscale in a cross-sectional image, birefringence is observed as a characteristic banding pattern.

For example, the apparatus of FIG. 4 can be modified to include a galvanometric scanner so that the OFDI beam may be repetitively scanned across the surface of the tissue while the sample was held stationary and the 1450 nm laser spot remained fixed on center, as shown in FIG. 27. As shown in FIG. 27, the treatment light can be delivered through a first collimator 2500 providing a treatment beam 2510 incident on the tissue 2550 that is covered by a cover slip 2540 and against a backing 2560. The imaging light may be provided by a second collimator 2570 producing an imaging beam 2580 that is directed by a galvo-mirror 2520 through a lens 2530. This arrangement/system can be an exemplary embodiment of a therapeutic monitoring system applicable to applications in dermatology. OFDI images or video of esophageal and duodenal tissues were acquired during laser irradiation.

FIGS. 7A-7D show images of the representative data. In frames acquired prior to laser irradiation, the layered esoph-

ageal structure can be observed in the intensity image **2450** (see FIG. 7A) and characteristic birefringence banding can be observed in the corresponding polarization image **2460** (see FIG. 7B). In frames acquired during laser exposure, the epithelial scattering intensity may be increased dramatically within the 1.1 mm laser spot **2470** (see FIG. 7C), and the birefringence banding in the corresponding polarization image **2480** (see FIG. 7D) can be lost. Reviewing the polarization moving images in slow-motion, a zone of decreased birefringence can be observed that may begin near the surface and propagated downward. These observations are generally consistent with a downward propagating zone of denatured tissue. Measurements of the percent-loss of birefringence is a quantitative metric for monitoring laser thermal damage.

Scattering

Thermally induced changes to the microscopic structure of tissue can alter optical scattering. Since the signal in OFDI arises from scattering and small changes can be detected over a large dynamic range, we investigated the use of scattering measurements for monitoring thermally induced changes in tissue. Scattering changes observed in image **2460** of FIG. 7B may be representative of the preliminary observations in both duodenum and esophagus samples. In certain cases, it was determined that the significant scattering changes within the epithelium and relatively smaller changes in the underlying tissues of the muscularis mucosa and muscularis propria. For example, two potential quantitative metrics for laser damage that could be obtained from scattering measurements: changes in the depth-resolved scattering intensity and changes in the depth-integrated scattering intensity.

Blood Flow

Laser therapy can to alter vessels and capillaries resulting in decreased blood flow (as described in publication 54 identified below). Since the esophageal mucosa is highly vascularized, monitoring changes in blood flow may provide an additional method for monitoring laser therapy. An image **2490** of FIG. 8, acquired during our recent swine studies, graphically illustrates the porcine esophageal vascularity. This exemplary image **2490** was generated by unwrapping the tubular image data to display the epithelial surface as if the esophagus was longitudinally opened and pinned flat. The intensity data has been integrated over depth into the tissue. Although this type of large scale visualization is a convenient way to map the vessels, it is possible to use a more sensitive and quantitative method/technique/system for measuring blood flow. Doppler OCT (as described in publications 55 and 56 identified below) has been demonstrated for visualizing and quantifying blood flow in tissue and has been investigated as an arrangement for assessing flow following laser therapy (as described in publication 57 identified below). The Doppler measurements with OFDI (as described in publication 24 identified below) have been described, and the possibility of simultaneously measuring structure and flow in vivo has been reviewed.

A cross-sectional view of an exemplary image **2590** of FIG. 9 has been acquired in the esophagus of a living swine and displays intensity as a grayscale and Doppler as a superimposed color. The coordinates (r,θ) of this data have been mapped to Cartesian coordinates (vertical, horizontal) for simplicity of display. This result was representative of our observations at multiple locations in two swine. Additionally, in time-sequences of Doppler images, we clearly observed pulsatile flow.

Summary of Monitoring

Cause	Effect	Measurement
Thermal denaturing of cellular proteins and collagen	Focal deformation Loss of birefringence Δ Scattering	Phase & Speckle Polarization Intensity
Thermal coagulation of vessels	Loss of blood flow	Doppler flow & Vascular Map

Based on the preliminary investigation, the proposed measurements would likely be complementary; and the phase-shift and speckle decorrelation, which are only applicable during laser irradiation, may be more sensitive and provide greater spatial resolution. The changes in birefringence, scattering and flow are persistent and could be applied for follow-up imaging after laser treatment.

Exemplary Control

In addition to monitoring for laser thermal injury, effective conformal laser therapy may use precise control over the volume of treated tissue. One exemplary approach to controlling treatment depth is to operate within the conditions for thermal confinement in order to minimize collateral damage and to manipulate laser wavelength, power, and exposure time to control the depth of thermal injury. In the transverse dimension (along the epithelial surface), thermal injury can be controlled through the use of a raster-scanned, spatially-collimated beam. A flat-top beam with a diameter of 1-3 mm with well-defined edges may allow spatial control while also permitting therapy of large epithelial areas through raster scanning. Exemplary laser control parameters are described herein below in the context of Eq. 1. The temperature distribution of Eq. 1 generally applies only in the limit of weak scattering.

Wavelength

From the temperature distribution of Eq. 1, it is evident that μ_a would likely be an optimal parameter for control over depth of laser injury. Although μ_a is characteristic of the sample rather than an externally controllable parameter, in this invention we exploit the wavelength dependence of μ_a to achieve depth control. In this invention, we target the absorption coefficient at longer wavelengths where water absorption dominates. Since the water content is approximately constant in epithelial tissues, thermal injury depth can be closely regulated by changing the laser wavelength by small amounts. In the vicinity of the water absorption band near 1.45 μm , absorption lengths (see graph **2595** of FIG. 10) range from 0.3 mm to over 2 mm within a narrow spectral range (1375 nm to 1430 nm). These lengths correspond well to the characteristic length scales appropriate for the treatment of epithelial disease. A tunable laser, operable in the vicinity of the 1450 nm water absorption band can be used to control therapy through wavelength tuning.

Power and Exposure Duration

Upon the review of Eq. 1, the absorption coefficient does more than control the exponential depth decay of the temperature distribution; e.g., it also can control the amplitude. Since the amplitude term is also dependent upon power density and exposure duration, these variables can be used to normalize the amplitude while allowing the absorption coefficient to change.

Procedure Duration

In the evaluation of a proposed new therapy, it may be important to estimate the preferable procedure time and evaluate this estimate in the context of competing approaches and constraints specific to the clinical setting and patient acceptance. PDT is currently applied for the treatment of BE

in the endoscopy setting and requires procedure times on the order of 20 minutes. For the exemplary conformal laser therapy technique, the procedure performance time may be estimated by $2At/(\pi rv)$, where A is the treatment area, r is the laser spot radius, and v is the laser spot scan velocity. For an esophageal treatment length of 60 mm and an esophageal diameter of 20 mm.

According to the exemplary embodiment of the present invention, a combined system can be provided which may allow for a controlled laser excitation. In one exemplary embodiment, the exemplary system can be used endoscopically for conformal laser therapy capable of comprehensively treating epithelial lesions while minimizing collateral damage to adjacent tissues.

Exemplary System Design

According to the exemplary embodiment of the present invention, a system can be provided for performing conformal laser therapy of epithelial disease through a combination of monitoring and control. Since laser beams can easily be shaped and spatially scanned and since margins in the transverse plane (along the surface of the esophagus) are less critical, the primary challenge for achieving accurate control of laser therapy is in limiting and adjusting the depth of laser damage. Based on the modeling and analysis described above, it is possible to utilize laser wavelength and power and scanning speed to vary the depth of laser damage over a clinically significant range while not significantly altering the transverse extent of injury.

Exemplary Therapy Laser Arrangement

The laser wavelengths between approximately 1375 nm and 1430 nm can provide absorption lengths ranging from over 2 mm to less than 0.3 mm. Semiconductor lasers can operate in this spectral range. Since such lasers can be compact and environmentally stable, these laser can be effectively used in clinical applications. Materials suitable for this specific wavelength range, however, may not be standard. A less expensive alternative for the early testing phase of exemplary embodiments of the methods according to the present can be provided by a solid-state laser material, tetravalent chromium-doped YAG (Cr⁴⁺:YAG). For example, a tunability with this material over the spectral range of 1340 nm-1570 nm can be implemented (as described in publications 58 and 59 identified below). The exemplary design and construction of tunable solid-state lasers that operate in the near infrared spectral range are described in publications 60-65 identified below. An electromechanical shutter, external to the laser resonator, can be used to turn on/off the exemplary laser.

Exemplary Benchtop System

An exemplary embodiment of a benchtop optical system according to the present invention may be provided that can be similar to the systems shown in FIGS. 4 and 27 and described herein. For example, the OFDI sampling beam may be focused at the sample to a diameter of ~25 μ m. The axial location of the focus can be determined using a standard z-scan technique, and may be registered within the OFDI cross-sectional image. The subsequent axial positioning of the samples within the OFDI image window may ensure a constant focus location for all samples. Data may be collected with the two beams fixed with respect to each other and while the sample is translated perpendicular to the laser beam axis.

Exemplary Positioning and Registration of Laser and OFDI Beams

According to the exemplary embodiment of the present invention, the offset between the OFDI beam and the center of the laser spot is not critical for monitoring. OFDI data may be collected for various offsets (as depicted in FIG. 4) to determine the offset that yields the greatest indicated depth of

thermal injury. This offset can then be used in all subsequent studies and may be registered as follows. A small, low-power, short-duration epithelial burn may be induced on the surface of the sample while the sample is held fixed (non-translating).

As shown in FIG. 7, the increase in epithelial scattering can be readily observed in OFDI and is spatially localized as defined by the laser beam profile. Although not illustrated in FIG. 4, the OFDI beam can be relayed to the focusing lens by a pair of galvanometers that provide two-dimensional scanning. The galvanometers may be used to generate an en face OFDI image of the sample and the epithelial burn may appear as a circle of increased scattering. The galvanometers can then be positioned and fixed so that the OFDI beam is positioned with the desired offset (as schematically shown in FIG. 4).

Exemplary Wavelength Scaling

One of the purposes of this experiment is to test the exemplary technique and method of wavelength variation and power normalization according to the present invention for achieving clinically relevant variation in the depth of laser damage. Laser wavelength may be varied from about 1375 nm to 1405 nm in 2 nm steps with laser spot size and scanning speed held constant. For each wavelength, the laser power may be adjusted so that the product $P^d \oplus \mu_z$ in Eq. 1 can be maintained as constant. This should yield lines of constant width and with damage depth ranging from approximately 0.25 to 1.5 mm.

Exemplary Scanning Velocity Scaling

One exemplary embodiment according to the present invention for affecting therapeutic depth may include scaling the scan velocity. For example, the therapy beam scan speed can be varied from 1 mm/s to 5 mm/s. Slower scan speeds allow time for heat to conduct to deeper areas of the tissue, producing deeper therapy.

Exemplary Positioning and Registration of Laser and OFDI Beams

To ensure accurate therapeutic monitoring, the spatial relationship between the OFDI sampling beam and the laser spot can be controlled.

Exemplary Endoscopic Probe Designs

One exemplary embodiment of the present invention can include an endoscopic probe for comprehensive, volumetric imaging and simultaneous laser therapy, as shown in FIG. 11. For example, two beam relay optics **2640a** and **2640b** may be used, one of which conveys imaging light **2640b** and the other therapy light **2640a**. These relay optics are placed within a housing **2630** that is enclosed within a first transparent sheath **2600**. A balloon centration mechanism (as described above) **2620** may be used to maintain a constant distance between the optical probe **2630** and the tissue surface **2610**. Laser light and the OFDI beam may be delivered through separate optical fibers **2641a** and **2641b**. Each fiber may have its own relay optics to produce independently controllable spot sizes. A further exemplary embodiment of the present invention can include these relay optics designed to produce overlapping spots. The optical fibers and distal optics may be housed in a wound-wire drive shaft and placed inside a balloon-centering probe identical to the balloon sheaths.

Longitudinal scans can be activated using a computer controlled translation stage attached to the proximal end of the drive shaft. This exemplary arrangement may be the same as the arrangement which can be used for the pull-back esophageal imaging of our preliminary studies. A manual rotation of the drive shaft may be possible, as is automated rotation using an exemplary rotary coupler **2900** shown in FIG. 13. In one exemplary embodiment of the present invention, an endoscopic system may screen for disease over large fields-of-view, accurate monitoring of laser-tissue interaction, and pre-

cisely control laser therapy. One of the applications of such exemplary embodiment may be the identification and treatment of epithelial cancers and their precursors. In a further exemplary embodiment, the system can incorporate procedures and software modules than can directly link screening, monitoring, and control.

In yet another exemplary embodiment, the system may be used to generate a high-resolution, 3-dimensional map of the entire distal esophagus to facilitate therapeutic planning. Thereafter, the use may be presented with a 'live' cross-sectional image comprising three sections, as illustrated in FIG. 14. A right section 2700 of the image may be the tissue immediately ahead of the therapeutic lase, the center 2730 of the image may be the location of the laser with a marker 2740 designating the zone of therapy, and the left section 2710 of the image may be the tissue that has already been treated. Since the three beams may be continuously scanning, the tissue may appear to move from right to left as the image updates. The user (e.g., an endoscopist) may operate a control servo to start/stop the treatment and increase or decrease the depth of therapy. By viewing the zone of treatment 2710 and looking ahead to the untreated tissue 2700, the user may be able to steer and conform the region of laser therapy to the desired target.

An exemplary embodiment of the endoscopic probe for imaging, monitoring and laser therapy through a centering balloon according to the present invention is shown in FIG. 12. This exemplary probe can rotate to scan the esophagus circumferentially and may be longitudinally translated at a slower rate to define segments for therapy. This probe may include, e.g., three or more optical channels: a first channel 2800c for imaging the tissue prior to laser irradiation, a second channel 2800b for treatment, and a third channel 2800a for monitoring. Each optical fiber may be separately imaged transversely onto the esophageal wall through the balloon. The alignment of the resulting output beams may be such that, upon rotation in the clockwise direction, the imaging beam precedes the treatment beam sufficiently so that non-treated tissue may be sampled. The monitoring beam may be aligned to fall within the laser spot. Following initial alignment of the three beams, the optics may be bonded together with epoxy, and the alignment may be fixed.

Exemplary Rotary Junction

An exemplary rotational coupler according to the present invention which can connect the three-channel catheter to the OFDI system is shown in FIG. 13, and can be referred to "watch-spring" rotary junction (since it can rely on two concentric spools). For example, as the inner spool 2900 rotates in one direction, optical fiber is wound from the outer spool 2910 onto the inner spool 2900. On reversing the direction, the fiber can unwind from the inner spool. Ribbon optical fiber may be used and two parallel plates 2920 with a gap matched to the ribbon width can ensure that the windings remain flat and do not bind. The plates may be sufficiently large so that up to, e.g., 100 rotations may be possible prior to requiring counter rotation. With a 1 mm laser spot, full treatment of 6 cm long esophageal segments may be 60 revolutions. A plate diameter of less than 10 cm can be used. In addition to accommodating three optical channels, this exemplary embodiment of the arrangement and system according to the present invention can avoid the loss and back-reflections that arise from air-gap couplers.

Exemplary High-Speed Acquisition and Processing

A further exemplary embodiment of the system and arrangement according to the present invention can utilize, e.g., a high-speed imaging system. The exemplary embodiment of the digital acquisition and processing system can be

based on VME-bus hardware for acquiring, processing and storing the OFDI signals in real-time. The exemplary components of such exemplary system and arrangement may comprise a VME chassis containing high-speed digitizers residing on a single-board computer and fiber-optic links to a RAID storage array. This exemplary system and arrangement can be controlled via a host processor (e.g., a personal computer). The analog OFDI signals may be digitized using wide-band receivers (e.g., 12 bit, 210 MS/s) with integrated field-programmable-gate-array (FPGA) processors. Processing power, resident on the acquisition board, may be important since the raw data rate may be 800 MB/s for the two polarization channels of the OFDI system. The FPGA processor can be configured or programmed to transform each polarization channel from the frequency-domain to a 1024-element array representing reflectivity versus depth (one A-line). This data can be passed to the single-board computer for subsequent processing and for combining the two channels prior to transferring the final data to a RAID array of hard drives. The final data storage rate may be, e.g., 400 MB/s. By striping the data across multiple hard drives, this data rate can be continuously sustained.

Software on a processing arrangement in accordance with an exemplary embodiment of the present invention can permit a user control over the exemplary system, and may enable a display of the images at a down-sampled rate in real-time. For example, the exemplary system can be used in two exemplary modes: a burst mode at full data rate, and continuous mode at half data rate. The exemplary endoscopic system and arrangement can include the components and software described above, and additional procedures (e.g., software) can be provided to program both the FPGA processor and single-board computer to facilitate the computations of phase-shift, birefringence, speckle, and Doppler signals in real-time. The combined computational capacity of the Vertex 4 Pro FPGA and quad G4 single-board computers may be ample for displaying the monitoring signal in real-time.

Exemplary Laser

Using Eq. 1, the spot size while maintaining a constant scan velocity can be doubled by using a 4-fold increase in the laser power in order to maintain a constant temperature distribution in the tissue. Doubling the scan velocity at a constant spot size should use a doubled laser power. One exemplary embodiment of a laser arrangement in accordance with the present invention can utilize a single-emitter semiconductor laser diode. Previous devices have provided more than 3 W of laser power over this spectral range using a simple external cavity design including a diffraction grating for wavelength control. The laser power and wavelength may be controlled via the host processing arrangement of the OFDI system based on an analog signal from a potentiometer. The potentiometer may be a hand-held dial that the user (e.g., an endoscopist) may use to increase or decrease the depth of laser damage.

Exemplary User Interface

The exemplary embodiment of the system and method according to the present invention can provide a user interface to the operator that includes a cross-sectional image of the tissue. The image may be continuously updated and may include views of treated and upcoming, untreated tissue as well as a designation for the zone of laser treatment as determined by the monitoring procedures. The user interface may be programmed on the host processing arrangement, and can use computational results from the FPGA processor and single-board computer. Images and laser parameters may be archived to the RAID array.

In one further exemplary embodiment of the present invention, the imaging system/arrangement 100 can be connected

to a three-fiber probe using an optical switch **115** as shown in a block diagram of FIG. **15**. The exemplary probe, such as that described above with reference to FIG. **12**, can include two imaging fibers and one therapy fiber. The switch **115** can alternately couple imaging light to one of the two imaging fibers **120a**, **120b** which can be used to acquire re-therapy images and, e.g., during-therapy imaging. A therapeutic light source **105** may connect directly to the therapy fiber **125c**. The fibers can be connected to the catheter **130**, which can be, e.g., the exemplary catheter shown FIG. **12**. A signal from the imaging system **100** can control the state of the optical switch **115**.

In yet another exemplary embodiment according to the present invention shown in FIG. **16**, the exemplary imaging system/arrangement **200** can be coupled to an exemplary three-port catheter such as one shown in FIG. **12** via an optical splitter **215** that can couple light to both of two imaging fibers **220a**, **220b**. This exemplary imaging system can separate the image signal from each using path-length encoding techniques. To generate the differential path length, an optical delay **235** may be placed in one fiber **220b** or multiple fibers. The therapeutic light source **205** can be coupled directly or indirectly to the therapy fiber **225c** of the catheter.

In still another exemplary embodiment of the exemplary imaging system/arrangement **800** according to the present invention shown in FIG. **17**, light may be combined with the therapy source **805** using a single wavelength-division multiplexer **810**. The combined light may be coupled to a single fiber rotary coupler, and then to an exemplary single fiber catheter such as the catheter shown in FIG. **21**.

In a further exemplary embodiment of the imaging system/arrangement **900** according to the present invention shown in FIG. **18**, light may be combined with the therapy light **905** using a cladding mode coupler that couples the imaging system **900** light from the single mode fiber **901** to the single mode core of a dual-clad fiber **911** and the therapy light from a multimode fiber **906** to the cladding mode of a dual-clad fiber **911**.

FIG. **19** shows exemplary connections between a system **400** with three output fibers **405a**, **405b**, **405c**, such as one shown schematically in, e.g., FIGS. **15** and **16**, and a three-port catheter **415**, such as one shown in FIG. **12** via a multi-channel rotary coupler **410**, such as one shown in FIG. **13**.

FIG. **20** shows a schematic diagram of an exemplary system **300** according to the present invention in which a single fiber **305** containing both the imaging light and therapy light may be coupled to a single-channel rotary coupler **310**. For example, after the rotary coupler **310**, the light can be divided by a wavelength-division multiplexer (WDM) **330** that separates the imaging light onto a first fiber **332** and the therapy light onto a second fiber **331**. The imaging light may further be separated using an optical splitter **335** that creates two imaging ports **336a** and **336b**. The fibers **31**, **336a**, **336b** can be connected to a three-port catheter **325** design such as that shown in FIG. **12**. The catheter section **320** may be flexible allowing endoscopic insertion and the section containing a WDM **330** and a splitter **335** can be enclosed within a rigid tube **315** to protect these components.

FIG. **21** shows a side view of an exemplary embodiment of a distal optics arrangement according to the present invention that may create a single imaging beam **1125** and a separate therapy beam **1120** from a single-mode fiber **1101**. For example, the light from the fiber containing both imaging and therapy light can first be focused by a first GRIN lens **1100**. The light is then passed into a wavelength-division multiplexing prism **1105** that can direct the therapy light wavelengths upward to create the therapy beam **1120**, and transmits the

imaging light wavelengths to a second GRIN lens **1110**, which can alternately focus the imaging light and directs it to a final prism **1115** that directs the imaging beam **1125** upward. The angle of the prisms **1105** and **1115** may be such that the beams are made to overlap at the appropriate distance from the device.

FIG. **22** shows side and front views of an exemplary embodiment of a three-port catheter in accordance with the present invention. The exemplary catheter can include three fibers **1005** that connect to three sets of focusing optics **1035** contained in a V-groove **1020** inside a housing **1040**. The focusing optics can provide beam focusing. Micro-prisms **1025** can redirect the optical beam upward through a cylindrical lens **1030** that corrects for astigmatism induced by the transparent sheath **1000**. A balloon **1010** centration mechanism may be used to maintain centering of the optics **1035** within the luminal tissue **1015**. In the end-view, the monitoring beam **1050c**, therapy beam **1050b**, and pre-imaging beam **1050a** can be seen. The housing **1040** can be adapted to rotate by a multichannel rotary coupler such as one shown in FIG. **13**.

FIG. **23** shows a side view of an exemplary embodiment of a catheter in accordance with the present invention which can utilize a miniature motor **1260** to achieve rotation of the imaging beam. For example, the motor **1260** can be enclosed within a transparent sheath **1235**. The rotation of the motor shaft can rotate a prism **1220**. The imaging light can be coupled to the distal optics via a fiber **1210**, where the light can be focused by focusing optics **1215**, and reflected onto the prism **1220** by a reflector **1225**. The rotation of the prism **1220** sweeps the imaging beam circumferentially. The motor electrical connections **1205** can be achieved through the same lumen as the fiber **1210**. The therapy light is coupled to the distal optics on fiber **1200**. This therapy light may be focused using focusing optics **1250**, and directed sideways by prism **1245** at a fixed rotational angle relative to the inner sheath **1235**. The imaging beam thus sweeps through the fixed therapy spot. The translation of the therapy spot is achieved by rotation of the entire inner sheath **1235** within the outer sheath **1240**. This exemplary rotation can be achieved through the use of a multi-channel rotary coupler such as a coupler shown in FIG. **13**. The catheter can use a balloon **1255** for centration of an optical core **1230**.

FIG. **24** shows a block diagram of an exemplary embodiment of a laser therapy source according to the present invention with wavelength tunability utilizing a low power wavelength tunable source **600**, followed by a broadband booster amplifier **605** to increase the optical power.

FIG. **25** shows a block and functional diagram of an exemplary embodiment of a laser therapy source incorporating multiple laser diodes **500a**, **500b**, **500c**, **500d** at different wavelengths and polarizations, and the exemplary procedure to implement such arrangement. For example, the light can be combined by the polarization multiplexers **505a**, **505b** and wavelength division multiplexers **510** to a single mode fiber **515**. Optionally, the light can be coupled to a multimode fiber **520**. A fast mode scrambler **525** can be used to scramble the transverse mode pattern output from the multimode fiber at a fast rate. Other source arrangements which can output light on a single mode fiber can use a similar design to couple light to a multimode fiber.

FIG. **26** shows an exemplary embodiment of a therapy light source and use thereof according to the present invention. For example, a laser diode bar **700** can be used with multiple wavelengths **701a-g**. Each waveguide can be coupled to a free-space laser cavity through a lens apparatus **705** and a grating **710** and a partially reflecting end mirror **715**. Because

of the wavelength dispersion of the grating, the laser formed by each waveguide lases at a different wavelength. Thus, by adjusting the drive current to each of the waveguides **701a-g**, the laser output **720** power and spectral shape can be adjusted.

In a further exemplary embodiment according to the present invention, a single OFDI system can be modified to facilitate a detection of both the imaging and monitoring signals through the use of acousto-optic frequency shifters as shown in FIG. **28**. For example, a wavelength swept laser source **3000** can be separated by a first splitter **3020** to produce a sample arm path and reference arm path. The radiation in the reference arm path can be forwarded to a circulator **3040** which can provide the radiation to a reflective arrangement **3050** (e.g., a mirror), which then forwards a return radiation to the circulator **3040**, thereby forwarding such radiation toward a combiner **3090**. The sample arm path is further separated by a second splitter **3030**, with a first output of this splitter being directed to a first frequency shifter **3061** and a second output being directed to a second frequency shifter **3060**. Each of the frequency shifters can be driven with a separate frequency. The light from the first frequency shifter **3061** can be coupled through an optical circulator **3071** to the imaging fiber **3072** of a three-fiber rotary coupler **3110** like that shown in FIG. **13**. The light from the second frequency shifter **3060** may be coupled through a circulator **3070** to a monitoring fiber **3073** of the same rotary coupler.

A separate therapy laser **3010** can be coupled to the third therapy fiber. The returned light on the imaging fiber **3072** and monitoring fiber **3073** may be recombined at an optical combiner **3080**, and mixed with the reference arm light at a second combiner **3090** with the output directed to a set of detectors **3100**. Due to the frequency shifters, the interference signal due to the imaging light and the interference signal due to the monitoring light are encoded at separate carrier frequencies and can be separated through conventional frequency domain techniques.

FIG. **29A** shows a flow diagram of an exemplary embodiment of a method for obtaining information associated with at least one portion of a sample according to the present invention. For example, a temperature change can be caused in the portion of the sample in step **3100**. At least one first electromagnetic radiation can be forwarded to a section near or in the portion of the sample in step **3110**. A deformation of the section can be identified at a plurality of depths as a function of (i) a phase of at least one second electro-magnetic radiation provided from the section, and/or (ii) a rate of change of the phase and/or an amplitude of the second electro-magnetic radiation in step **3120**.

FIG. **29B** shows a flow diagram of another exemplary embodiment of the method for controlling a temperature distribution in the sample according to the present invention. For example, an electro-magnetic radiation can be provided to the section in the sample at a particular wavelength in step **3130**. The temperature distribution can be controlled by modifying the particular wavelength of the electro-magnetic radiation when the electro-magnetic radiation can be provided to the section in step **3140**.

FIG. **29C** illustrates a flow diagram of yet another exemplary embodiment of the method for applying a laser radiation to at least one portion of a biological structure according to the present invention. For example, a beam of the laser radiation can be provided to the portion in step **3150**, whereas a cross-sectional area of the beam is at most about $\frac{1}{10}^{th}$ of an entire area of the at least one portion. In step **3160**, the beam can be applied to the portion (I) based on a predetermined

pattern, (II) while modulating a wavelength of the laser radiation, and/or (III) while monitoring a depth of the application of the laser radiation.

EXEMPLARY REFERENCES

1. Devesa S S, Blot W J and Fraumeni J F, Jr. Changing patterns in the incidence of esophageal and gastric carcinoma in the United States. *Cancer* 1998; 83:2049-2053.
2. Barr H, Stone N and Rembacken B. Endoscopic therapy for Barrett's oesophagus. *Gut* 2005; 54:875-884.
3. Johnston M H. Technology insight: ablative techniques for Barrett's esophagus—current and emerging trends. *Nature Clinical Practice Gastroenterology & Hepatology* 2005; 2:323-330.
4. Falk G W, Chittajallu R, Goldblum J R, Biscotti C V, Geisinger K R, Petras R E, Birgisson S, Rice T W and Richter J E. Surveillance of patients with Barrett's esophagus for dysplasia and cancer with balloon cytology. *Gastroenterology* 1997; 112:1787-1797.
5. Spechler S J. Barrett's esophagus: should we brush off this ballooning problem? *Gastroenterology* 1997; 112:2138-2142.
6. Kubba A K, Poole N A and Watson A. Role of p53 assessment in management of Barrett's esophagus. *Dig Dis Sci* 1999; 44:659-667.
7. Reid B J. p53 and neoplastic progression in Barrett's esophagus. *Am J Gastroenterol* 2001; 96:1321-1323.
8. Sharma P, Weston A P, Topalovski M, Cherian R, Bhattacharyya A, Sampliner R E. Magnification chromoendoscopy for the detection of intestinal metaplasia and dysplasia in Barrett's oesophagus. *GUT* 2003; 52: 24-27.
9. Kuipers E J and Haringsma J. Diagnostic and therapeutic endoscopy. *Journal of Surgical Oncology* 2005; 92:203-209.
10. Georgakoudi I, Jacobson B C, Van Dam J, Backman V, Wallace M B, Muller M G, Zhang Q, Badizadegan K, Sun D, Thomas G A, Perelman L T and Feld M S. Fluorescence, reflectance, and light-scattering spectroscopy for evaluating dysplasia in patients with Barrett's esophagus. *Gastroenterology* 2001; 120:1620-1629.
11. Adrain A L, Ter H C, Cassidy M J, Schiano T D, Liu J B and Miller L S. High-resolution endoluminal sonography is a sensitive modality for the identification of Barrett's metaplasia. *Gastrointest Endosc* 1997; 46:147-151.
12. Canto M I. Vital staining and Barrett's esophagus. *Gastrointest Endosc* 1999; 49:S12-16.
13. Huang D, Swanson E A, Lin C P, Schuman J S, Stinson W G, Chang W, Hee M R, Flotte T, Gregory K, Puliafito C A and Fujimoto J G. Optical coherence tomography. *Science* 1991; 254:1178-1181.
14. Tearney G J, Brezinski M E, Bouma B E, Boppart S A, Pitvis C, Southern J F and Fujimoto J G. In vivo endoscopic optical biopsy with optical coherence tomography. *Science* 1997; 276:2037-2039.
15. Evans J A, Ponomeros J M, Bouma B E, Bressner J, Halpern E F, Shishkov M, Lauwers G Y, Mino-Kenudson M, Nishioka N S and Tearney G J. Optical Coherence Tomography to Identify Intramucosal Carcinoma and High Grade Dysplasia in Barrett's Esophagus. *Clinical Gastroenterology and Hepatology* 2005; 4:38-43.
16. Ponomeros J M, Brand S, Bouma B E, Tearney G J, Compton C C and Nishioka N S. Diagnosis of Specialized Intestinal Metaplasia by Optical Coherence Tomography. *Gastroenterology* 2001; 120:7-12.

17. Brand S, Poneros J M, Bouma B E, Tearney G J, Compton C C and Nishioka N S. Optical Coherent Tomography in the Gastrointestinal Tract. *Endoscopy* 2000; 32:796-803.
18. de Boer J F, Cense B, Park B H, Pierce M C, Tearney G J and Bouma B E. Improved signal-to-noise ratio in spectral-domain compared with time-domain optical coherence tomography. *Optics Letters* 2003; 28:2067-2069.
19. Choma M A, Sarunic M V, Changhuei Y and Izatt J A. Sensitivity advantage of swept source and Fourier domain optical coherence tomography. *Optics Express* 2003; 11:2183-2189.
20. Leitgeb R, Hitzenberger C K and Fercher A F. Performance of Fourier domain vs. time domain optical coherence tomography. *Optics Express* 2003; 11:889-894.
21. Yun S H, Teamey G J, de Boer J F, Iftimia N and Bouma B E. High-speed optical frequency-domain imaging. *Optics Express* 2003; 11:2953-2963.
22. Yun S H, Boudoux C, Teamey G J and Bouma B E. High-speed wavelength-swept semiconductor laser with a polygon-scanner-based wavelength filter. *Optics Letters* 2003; 28:1981-1983.
23. Oh W Y, Yun S H, Tearney G J and Bouma B E. 115 kHz tuning repetition rate ultrahigh-speed wavelength-swept semiconductor laser. *Optics Letters* 2005; 30:3159-3161.
24. Vakoc B J, Yun S H, de Boer J F, Tearney G J and Bouma B E. Phase-resolved optical frequency domain imaging. *Optics Express* 2005; 13:5483-5493.
25. Brown S B, Brown E A and Walker I. The present and future role of photodynamic therapy in cancer treatment. *Lancet Oncol* 2004; 5:497-508.
26. van den Boogert J, van Hillegersberg R, Siersema P D, de Bruin R W and Tilanus H W. Endoscopic ablation therapy for Barrett's esophagus with high-grade dysplasia: a review. *Am J Gastroenterol* 1999; 94:1153-1160.
27. Sampliner R E, Fennerty B and Garewal H S. Reversal of Barrett's esophagus with acid suppression and multipolar electrocoagulation: preliminary results. *Gastrointest Endosc* 1996; 44:532-535.
28. Sampliner R E. Endoscopic ablative therapy for Barrett's esophagus: current status. *Gastrointest Endosc* 2004; 59:66-69.
29. Soetikno R M, Gotoda T, Nakanishi Y and Soehendra N. Endoscopic mucosal resection. *Gastrointest Endosc* 2003; 57:567-579.
30. Ganz R A, Utley D S, Stem R A, Jackson J, Batts K P and Termin P. Complete ablation of esophageal epithelium with a balloon-based bipolar electrode: a phased evaluation in the porcine and in the human esophagus. *Gastrointest Endosc* 2004; 60:1002-1010.
31. Mark H, Johnston, Brooks D, Cash, Cathy A, Dykes, Halisha S, Mays and Lavonne R. Johnston Cryoablation of Dysplasia in Barrett's Esophagus (BE) and Early Stage Esophageal Cancer. *Gastrointest Endosc* 2006; 63: AB223.
32. Overholt B F, Panjehpour M and Haydek J M. Photodynamic therapy for Barrett's esophagus: follow-up in 100 patients. *Gastrointest Endosc* 1999; 49:1-7.
33. Vogel A and Venugopalan V. Mechanisms of pulsed laser ablation of biological tissues. *Chemical Reviews* 2003; 103:2079-2079.
34. McKenzie A L. Physics of thermal processes in laser-tissue interactions. *Physics in Medicine & Biology* 1990; 35:1175-1209.
35. Anderson R R and Parrish J A. Selective photothermolysis: precise microsurgery by selective absorption of pulsed radiation. *Science* 1983; 220:524-527.

36. Jacques S L. Role of tissue optics and pulse duration on tissue effects during high-power laser irradiation. *Applied Optics* 1993; 32:2447-2454.
37. Nahen K and Vogel A. Investigations on acoustic on-line monitoring of IR laser ablation of burned skin. *Lasers in Surgery & Medicine* 1999; 25:69-78.
38. Jerath M R, Kaisig D, Rylander H G, 3rd and Welch A J. Calibrated real-time control of lesion size based on reflectance images. *Applied Optics* 1993; 32:1200-1209.
39. Jerath M R, Gardner C M, Rylander H G, 3rd and Welch A J. Dynamic optical property changes: implications for reflectance feedback control of photocoagulation. *Journal of Photochemistry & Photobiology B—Biology* 1992; 16:113-126.
40. Deckelbaum L I. Coronary laser angioplasty. *Lasers in Surgery & Medicine* 1994; 14:101-110.
41. Kim B M, Feit M D, Rubenchik A M, Mammini B M and Da Silva L B. Optical feedback signal for ultra short laser pulse ablation of tissue. *Applied Surface Science* 1998; 127-129:857-862.
42. Brinkmann R, Hansen C, Mohrenstecher D, Scheu M and Birngruber R. Analysis of cavitation dynamics during pulsed laser tissue ablation by optical on-line monitoring. *Selected Topics in Quantum Electronics, IEEE Journal of* 1996; 2:826.
43. Whelan W M, Davidson S R H, Chin L C L and Vitkin I A. A Novel Strategy For Monitoring Laser Thermal Therapy Based on Changes in Optothermal Properties of Heated Tissues. *International Journal of Thermophysics* 2005; 26:233-241.
44. Boppart S A, Herrmann J, Pitris C, Stamper D L, Brezinski M E and Fujimoto J G. High-resolution optical coherence tomography-guided laser ablation of surgical tissue. *Journal of Surgical Research* 1999; 82:275-284.
45. Thomsen S L, Jacques S L and Flock S T. Microscopic correlates of macroscopic optical property changes during thermal coagulation of myocardium. *Proceedings of the*
46. Maitland D J and Walsh J T, Jr. Quantitative measurements of linear birefringence during heating of native collagen. *Lasers Surg Med* 1997; 20:310-318.
47. Kimel S, Svaasand L O, Hammer-Wilson M, Schell M J, Milner T E, Nelson J S and Bems M W. Differential vascular response to laser photothermolysis. *Journal of Investigative Dermatology* 1994; 103:693-700.
48. Khan M H, Sink R K, Manstein D, Eimerl D and Anderson R R. Intradermally focused infrared laser pulses: Thermal effects at defined tissue depths. *Lasers in Surgery and Medicine* 2005; 36:270-280.
49. Neumann R A, Knobler R M, Pieczkowski F and Gebhart W. Enzyme histochemical analysis of cell viability after argon laser-induced coagulation necrosis of the skin. *Journal of the American Academy of Dermatology* 1991; 25:991-998.
50. Nadkarni S, Helg T, Bouma B E, Chan R C, Minsky M S, Chau A H, Motz J, Houser S L and Tearney G J. Characterization of atherosclerotic plaques by laser speckle analysis. *Circulation* 2005; 112:885-892.
51. Zimnyakov D A, Agafonov D N, Sviridov A P, Omel'chenko A I, Kuznetsova L V and Bagratashvili V N. Speckle-contrast monitoring of tissue thermal modification. *Appl Opt* 2002; 41:5989-5996.
52. Pierce M C, Sheridan R L, Park B H, Cense B and de Boer J F. Collagen denaturation can be quantified in burned human skin using polarization-sensitive optical coherence tomography. *Burns* 2004; 30:511-517.
53. de Boer J F, Milner T E, van Gemert M J C and Nelson J S. Two-dimensional birefringence imaging in biological

- tissue using polarization sensitive optical coherence tomography. *Optics Letters* 1997; 22:934-936.
54. Morelli J G, Tan O T, Garden J, Margolis R, Seki Y, Boll J, Carney J M, Anderson R R, Furumoto H and Parrish J A. Tunable dye laser (577 nm) treatment of port wine stains. *Lasers Surg Med* 1986; 6:94-99.
55. Chen Z P, Milner T E, Dave D and Nelson J S. Optical Doppler tomographic imaging of fluid flow velocity in highly scattering media. *Optics Letters* 1997; 22:64-66.
56. Izatt J A, Kulkarni M D, Yazdanfar S, Barton J K and Welch A J. In vivo bidirectional color Doppler flow imaging of picoliter blood volumes using optical coherence tomography. *Optics Letters* 1997; 22:1439.
57. Barton J K, Welch A J and Izatt J A. Investigating pulsed dye laser-blood vessel interaction with color Doppler optical coherence tomography. *Optics Express* 1998; 3:251-256.
58. French P M W, Rizvi N H, Taylor J R and Shestakov A V. Continuous-wave mode-locked Cr⁴⁺:YAG laser. *Optics Letters* 1993; 18:39-41.
59. Sennaroglu A, Pollock C R and Nathel H. Efficient continuous-wave chromium-doped YAG laser. *Journal of the Optical Society of America B* 1995; 12:930-937.
60. Bouma B, Gouveia-Neto A, Izatt J A, Russell J, Sierra R, Keller U and Fujimoto J G. Hybrid mode locking of a flash-lamp-pumped Ti:Al₂O₃ laser. *Optics Letters* 1994; 19:1858-1860.
61. Bouma B, Tearney G J, Boppart S A, Hee M R, Brezinski M E and Fujimoto J G. High-resolution optical coherence tomographic imaging using a mode-locked Ti:Al₂O₃ laser source. *Optics Letters* 1995; 20:1486-1488.
62. Bouma B E and Fujimoto J G. Compact Kerr-lens mode-locked resonators. *Optics Letters* 1996; 21:134-136.
63. Bouma B E, Nelson L E, Tearney G J, Jones D J, Brezinski M E and Fujimoto J G. Optical coherence tomographic imaging of human tissue at 1.55 μ m and 1.81 μ m using Er and Tm-doped fiber sources. *Journal of Biomedical Optics* 1998; 3:76-79.
64. Bouma B E, Ramaswamy-Paye M and Fujimoto J G. Compact resonator designs for mode-locked solid-state lasers. *Applied Physics B (Lasers and Optics)* 1997; 65: 213-220.
65. Bouma B E, Tearney G J, Bilinsky I P, Golubovic B and Fujimoto J G. Self-phase-modulated Kerr-lens mode-locked Cr:forsterite laser source for optical coherence tomography. *Optics Letters* 1996; 21:1839-1841.

The foregoing merely illustrates the principles of the invention. Various modifications and alterations to the described embodiments will be apparent to those skilled in the art in view of the teachings herein. Indeed, the arrangements, systems and methods according to the exemplary embodiments of the present invention can be used with and/or implement any OCT system, OFDI system, SD-OCT system or other imaging systems, and for example with those described in International patent application PCT/US2004/029148, filed Sep. 8, 2004, U.S. patent application Ser. No. 11/266,779, filed Nov. 2, 2005, and U.S. patent application Ser. No. 10/501,276, filed Jul. 9, 2004, the disclosures of which are incorporated by reference herein in their entireties. It will thus be appreciated that those skilled in the art will be able to devise numerous systems, arrangements and methods which, although not explicitly shown or described herein, embody the principles of the invention and are thus within the spirit and scope of the present invention. In addition, to the extent that the prior art knowledge has not been explicitly incorporated by reference herein above, it is explicitly being

incorporated herein in its entirety. All publications referenced herein above are incorporated herein by reference in their entireties.

What is claimed is:

1. An apparatus for applying a plurality of electro-magnetic radiations to a sample, comprising:
 - a first arrangement which is configured to provide the radiations, at least two of which are separated into a first radiation to be provided to the sample, and an additional radiation to be provided to a reference arm;
 - a catheter second arrangement having a specific portion with a plurality of channels, wherein one of the channels facilitates the first radiation to be forwarded to the sample that is within an anatomical structure, and another one of the channels facilitates a second radiation of the radiations to be forwarded to the sample, the first radiation having a first wavelength band, and the second radiation having a second wavelength band, wherein the first wavelength band is different from the second wavelength band,
 - wherein the channels further include a first fiber transmitting the first and second radiations, and wherein the first and second radiations transmitted via the first fiber are separated within a catheter body of the catheter second arrangement, and provided into the one of the channels having a second fiber and the other one of the channels having a third fiber, wherein the catheter body in which the separated first and second radiations are transmitted is configured to be inserted into the anatomical structure;
 - a processor third arrangement configured to (i) receive first information associated with the first radiation reflected from the sample, and (ii) determine an effect of the second radiation on the sample based on the first information; and
 - a rotary coupler arrangement which receives the radiations via at least one fourth fiber and provides the first radiation to the first fiber, wherein, when activated, the rotary coupler arrangement causes the specific portion to be continuously rotated within the anatomical structure.
2. The apparatus according to claim 1, wherein the catheter second arrangement includes a fourth arrangement having a single channel which, when transmitting at least one radiation, is in a simultaneous optical communication with at least two of the channels of the specific portion, and wherein the fourth arrangement is at least one of a fused fiber wavelength division multiplexer, a thin film wavelength division multiplexer, a grating or a dichroic mirror.
3. The apparatus according to claim 1, further comprising a fourth arrangement which is configured to detect an interference between a third radiation provided from the sample that is based on the first radiation and a fourth radiation provided from the reference that is based on the additional radiation.
4. The apparatus according to claim 1, wherein the first information is based on (i) a phase of the first radiation provided from the sample, or (ii) a rate of change of at least one of the phase or an amplitude of the first radiation.
5. The apparatus according to claim 1, wherein the processor third arrangement is further configured to monitor a change of the first information.
6. An apparatus for applying a plurality of electro-magnetic radiations to a sample, comprising:
 - a first arrangement which is configured to provide the radiations, at least two of which are separated into a first radiation and a second radiation to be provided to the sample, and an additional radiation to be provided to a reference arm; and

a catheter second arrangement having a specific portion with a plurality of channels, wherein one of the channels facilitates the first radiation to be forwarded to the sample that is within an anatomical structure, and another one of the channels facilitates the second radiation of the radiations to be forwarded to the sample, the first radiation being delivered to a first area of the sample, and the second radiation being delivered to a second area of the sample,

wherein each of the channels is structured to facilitate at least one particular radiation of the radiations to be forwarded to an anatomical structure that is within the sample, the radiations being delivered to different areas of the sample, and wherein centers of every one of the areas are provided along a line.

7. The apparatus according to claim 6, wherein a further one of channels facilitates a third radiation of the radiations to be forwarded to the sample, and wherein the third radiation is delivered to a third area of the sample that is separate from the first and second areas.

8. The apparatus according to claim 6, further comprising: a fourth arrangement having a single channel which is in an optical communication with at least two particular channels of the channels of the specific portion,

wherein a path from the single channel to the sample via one of the particular channels has a first optical distance, and a path from the single channel to the sample via another one of the particular channels has a second optical distance, and

wherein the first optical distance is different from the second optical distance by at least one of (i) at least 0.5 mm or (ii) at most 8 mm.

9. The apparatus according to claim 6, wherein the channels are structured to facilitate the transmission of the first radiation that has a first wavelength band, and the second radiation that has a second wavelength band, and wherein the first wavelength band is different from the second wavelength band.

10. The apparatus according to claim 6, further comprising a fourth arrangement which is configured to detect an interference between a third radiation provided from the sample that is based on the first radiation and a fourth radiation provided from the reference that is based on the additional radiation.

11. The apparatus according to claim 6, further comprising a processor third arrangement configured to (i) receive first information associated with the first radiation reflected from the sample, and (ii) determine an effect of the second radiation on the sample based on the first information.

12. The apparatus according to claim 6, wherein the channels include a first fiber transmitting the first radiation, and the apparatus further comprising a rotary coupler arrangement which receives the radiations via at least one second fiber and provides the first radiation to the first fiber, wherein, when activated, the rotary coupler arrangement causes the specific portion to be continuously rotated within the anatomical structure.

* * * * *