



US009181893B2

(12) **United States Patent**
Kim et al.

(10) **Patent No.:** **US 9,181,893 B2**
(45) **Date of Patent:** ***Nov. 10, 2015**

(54) **ELECTRONICALLY CONTROLLED FUEL INJECTION VALVE**

(75) Inventors: **Dong-Hun Kim**, Ulsan (KR);
Seung-Hyup Ryu, Ulsan (KR);
Tae-Hyung Park, Ulsan (KR)

(73) Assignee: **HYUNDAI HEAVY INDUSTRIES CO., LTD.**, Ulsan (KR)

(*) Notice: Subject to any disclaimer, the term of this patent is extended or adjusted under 35 U.S.C. 154(b) by 214 days.

This patent is subject to a terminal disclaimer.

(21) Appl. No.: **13/997,731**

(22) PCT Filed: **Dec. 23, 2011**

(86) PCT No.: **PCT/KR2011/010037**

§ 371 (c)(1),
(2), (4) Date: **Jul. 26, 2013**

(87) PCT Pub. No.: **WO2012/091367**

PCT Pub. Date: **Jul. 5, 2012**

(65) **Prior Publication Data**

US 2013/0332048 A1 Dec. 12, 2013

(30) **Foreign Application Priority Data**

Dec. 28, 2010 (KR) 10-2010-0136403
Dec. 28, 2010 (KR) 10-2010-0136405

(51) **Int. Cl.**

F02M 51/00 (2006.01)
F02D 41/38 (2006.01)
F02M 61/10 (2006.01)
F02M 63/00 (2006.01)
F02M 47/02 (2006.01)
F02M 61/20 (2006.01)

(52) **U.S. Cl.**

CPC **F02D 41/38** (2013.01); **F02M 47/02** (2013.01); **F02M 61/10** (2013.01); **F02M 63/001** (2013.01); **F02M 47/027** (2013.01); **F02M 61/205** (2013.01); **F02M 2200/50** (2013.01)

(58) **Field of Classification Search**

CPC **F02M 61/10**; **F02M 51/0671**
USPC **123/490**; **239/584**, **585.1**, **585.5**
See application file for complete search history.

(56) **References Cited**

U.S. PATENT DOCUMENTS

5,988,533 A 11/1999 Augustin
6,161,773 A 12/2000 Camplin et al.

(Continued)

FOREIGN PATENT DOCUMENTS

JP 07-324665 A 12/1995
JP 10-131828 A 5/1998

(Continued)

Primary Examiner — John Kwon

(74) *Attorney, Agent, or Firm* — Rabin & Berdo, P.C.

(57) **ABSTRACT**

An electronically controlled fuel injection valve can control the time to inject fuel and the amount of fuel to be injected in response to a control signal independently from the operating condition of an engine unlike a traditional mechanical fuel injection valve. The electronically controlled fuel injection valve employs a control method for fuel injection that increases the force of lifting up a cutoff needle of an injection controller by delivering high-pressure fuel to a lower pressure chamber via a control needle, thereby rapidly controlling fuel injection, has a simple structure making it easy to assemble, replace and precisely machine parts, and has a simple flow path structure which facilitates fabrication.

4 Claims, 11 Drawing Sheets

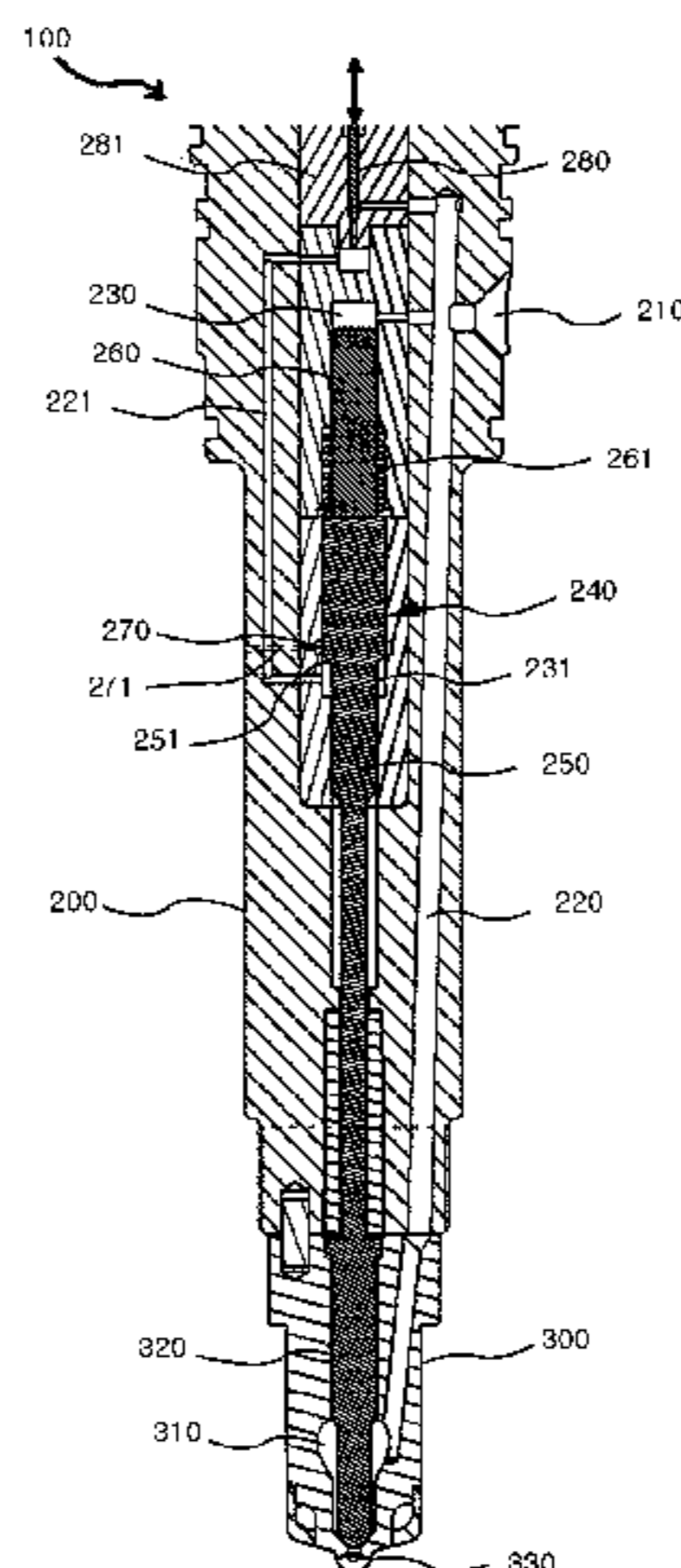

(56)

References Cited

FOREIGN PATENT DOCUMENTS

U.S. PATENT DOCUMENTS

2010/0199948 A1* 8/2010 Rogak et al. 123/304
2011/0006130 A1* 1/2011 Kondo et al. 239/71

JP 2000-087821 A 3/2000
JP 2010-249103 A 11/2010

* cited by examiner

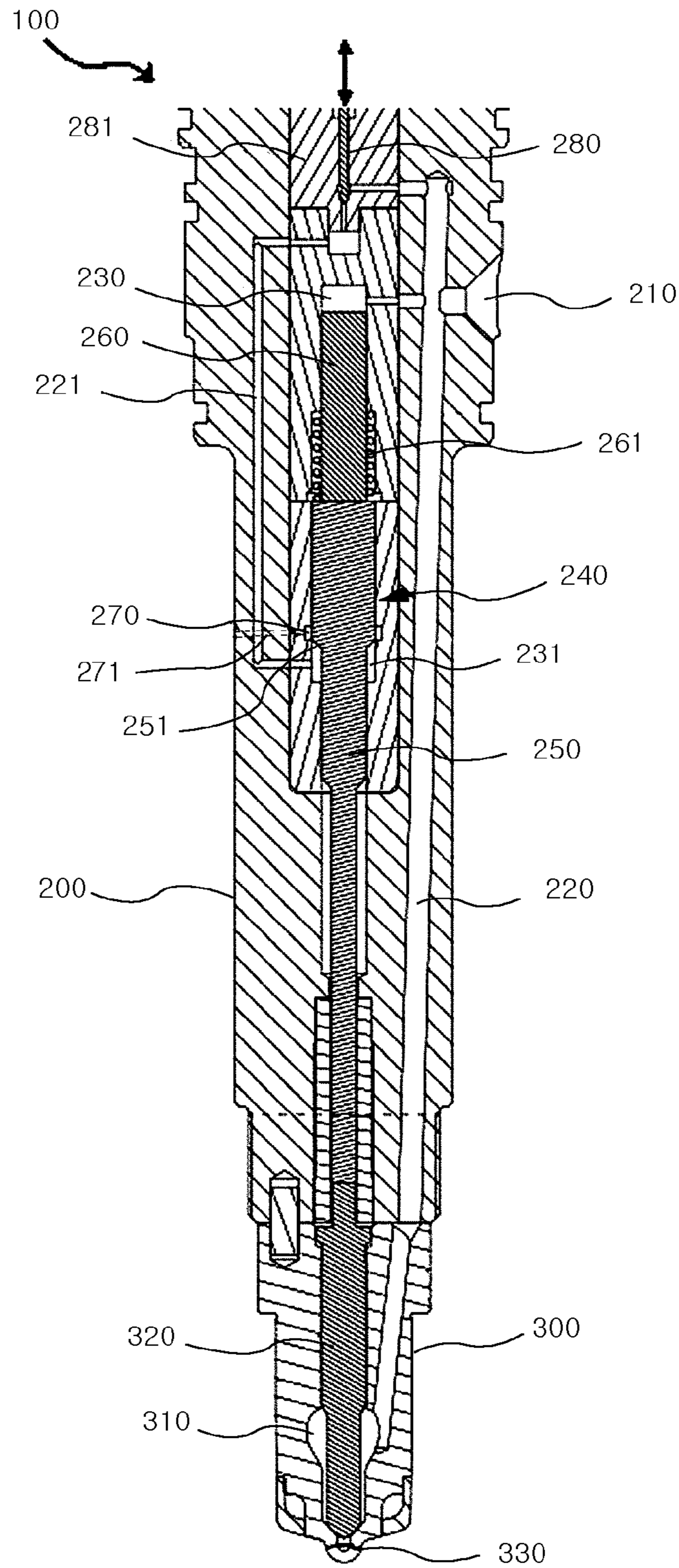

FIG. 1

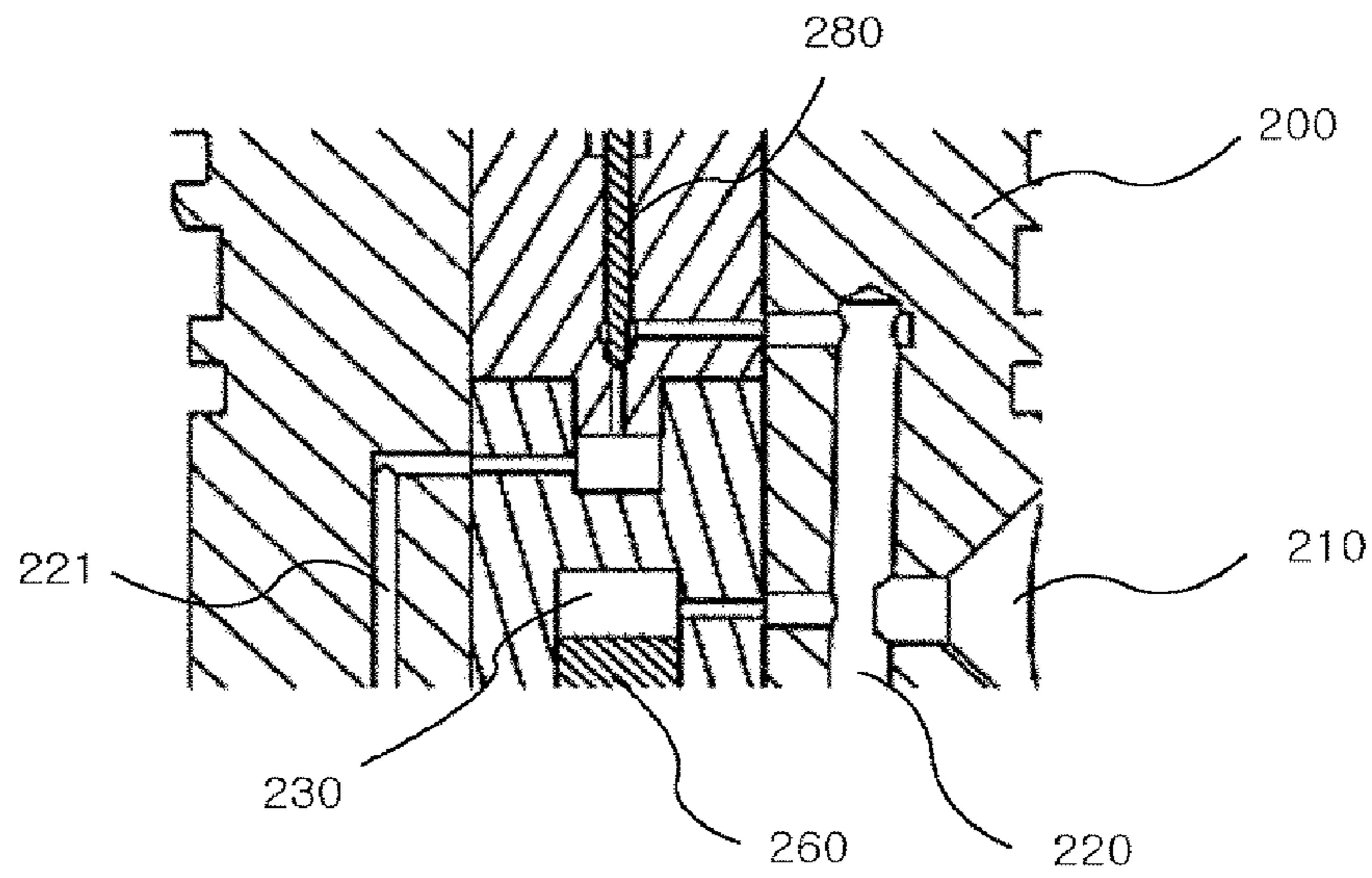

FIG. 2

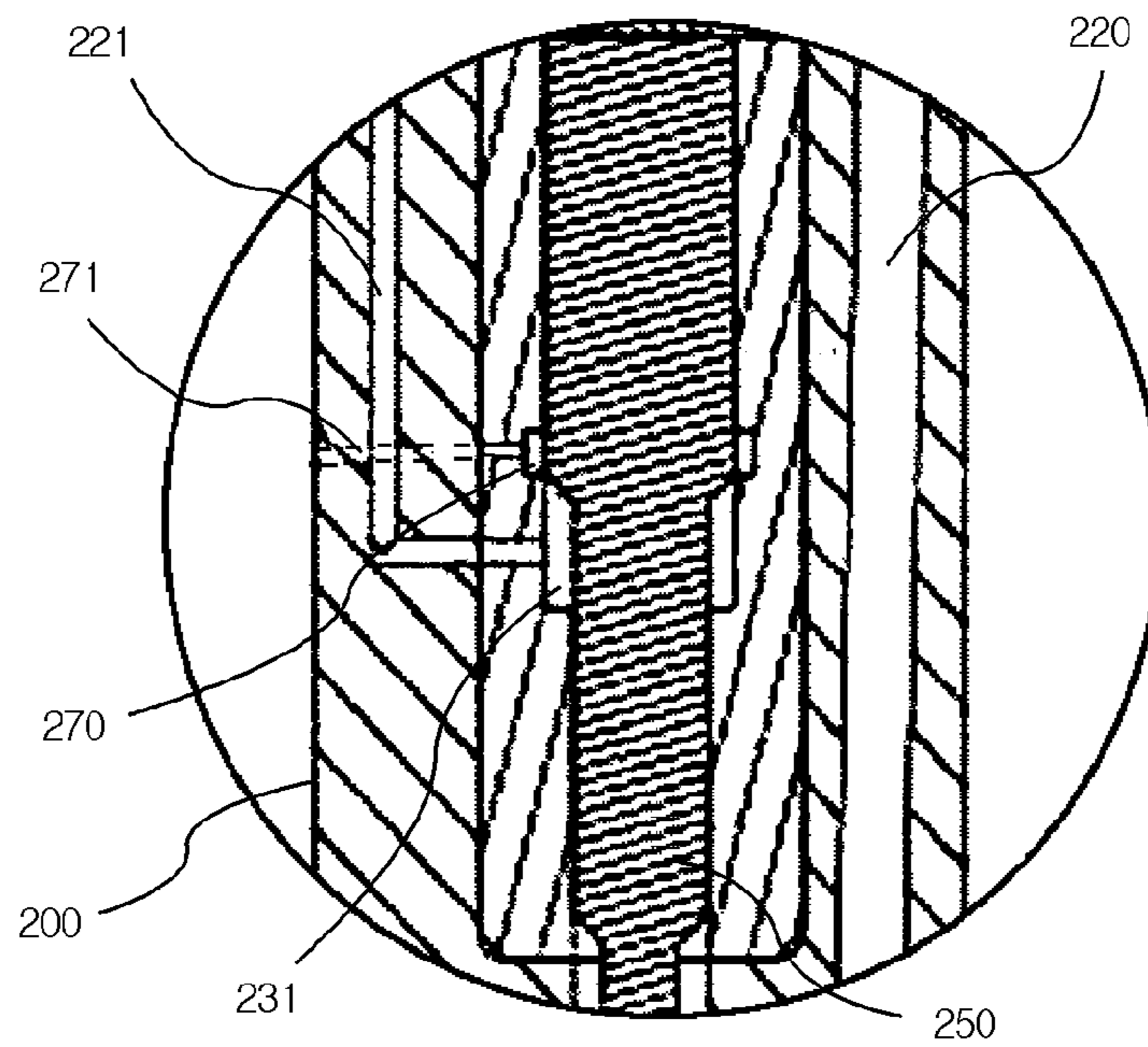

FIG. 3

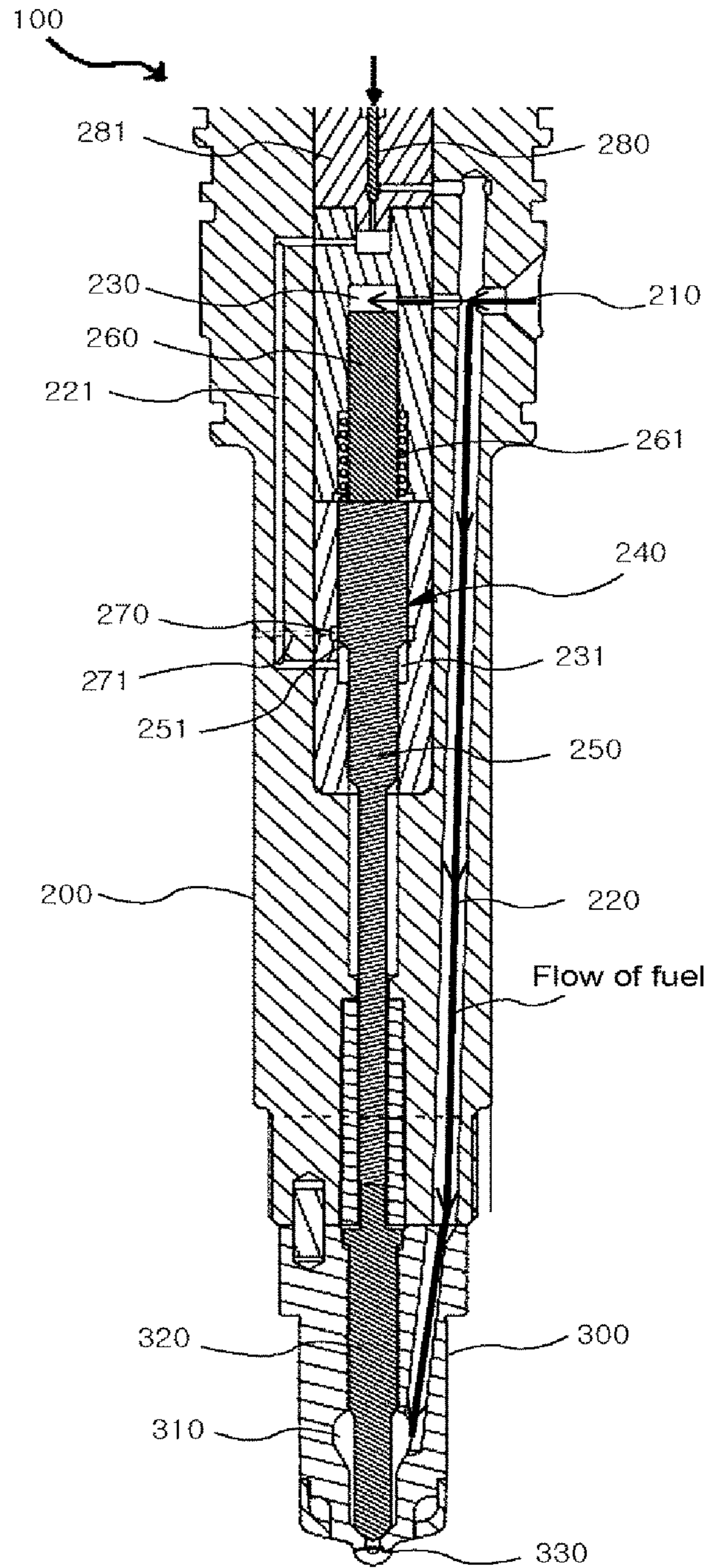

FIG. 4

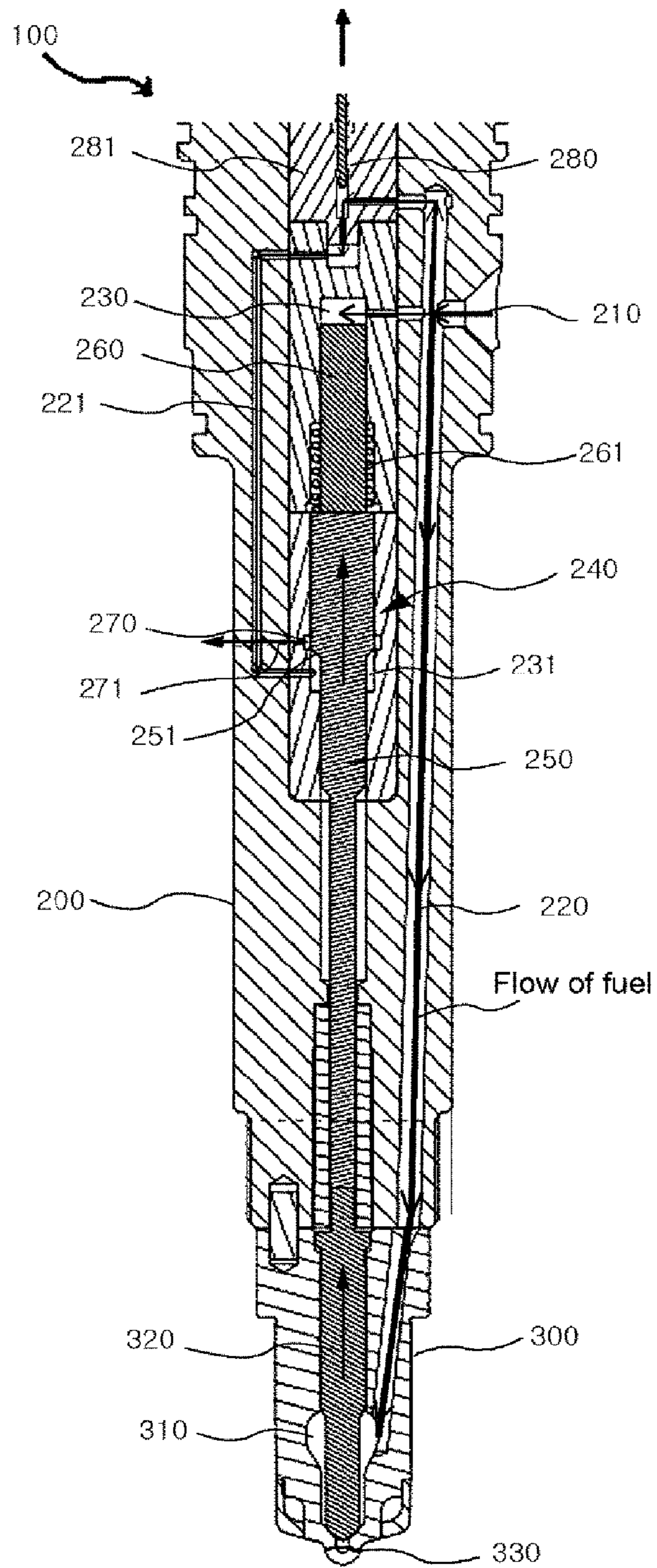

FIG. 5

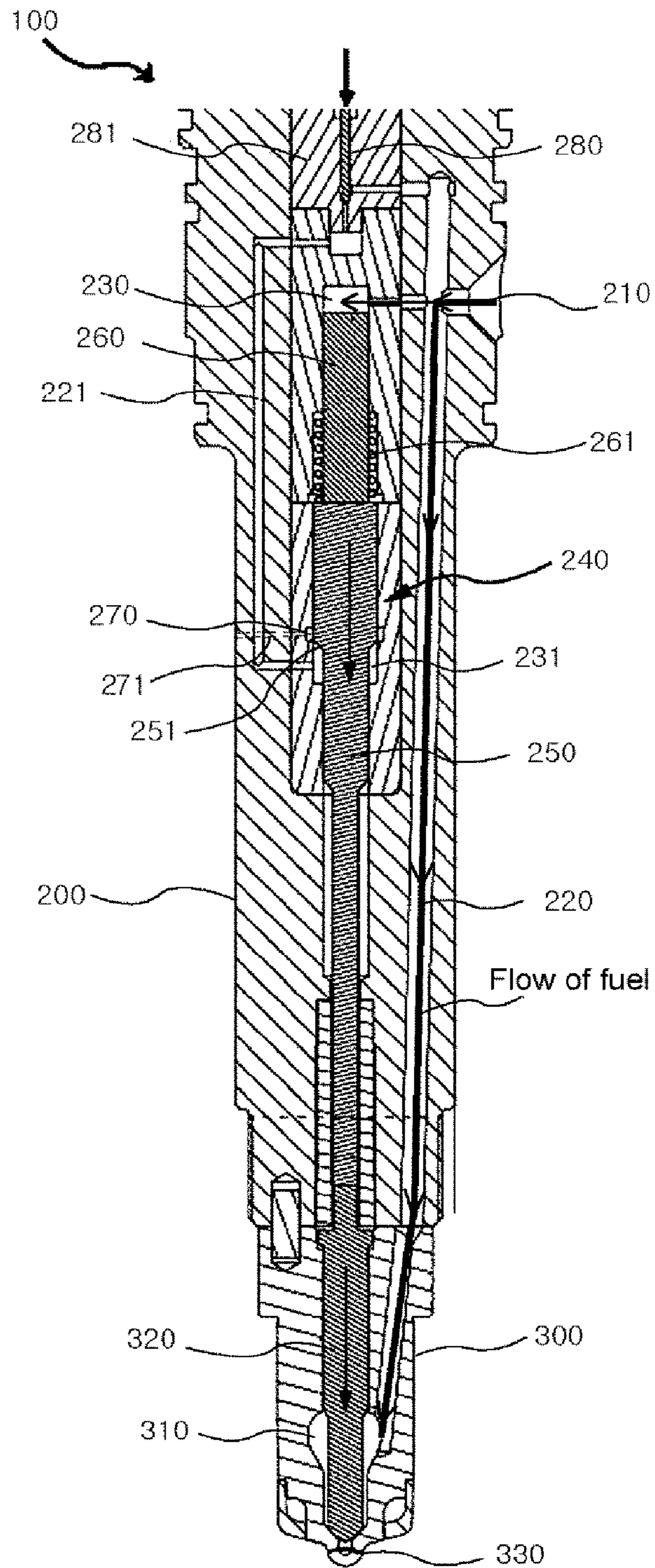

FIG. 6

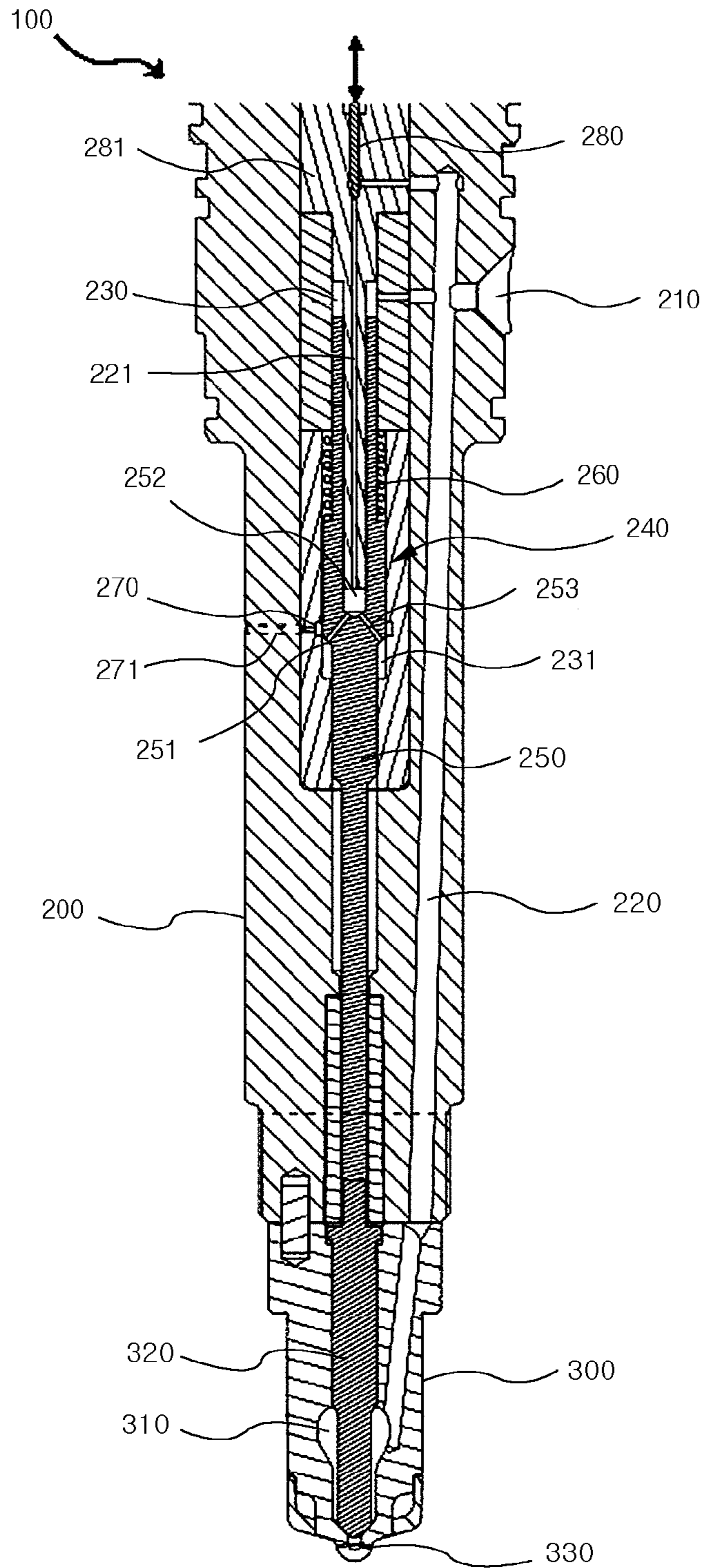

FIG. 7

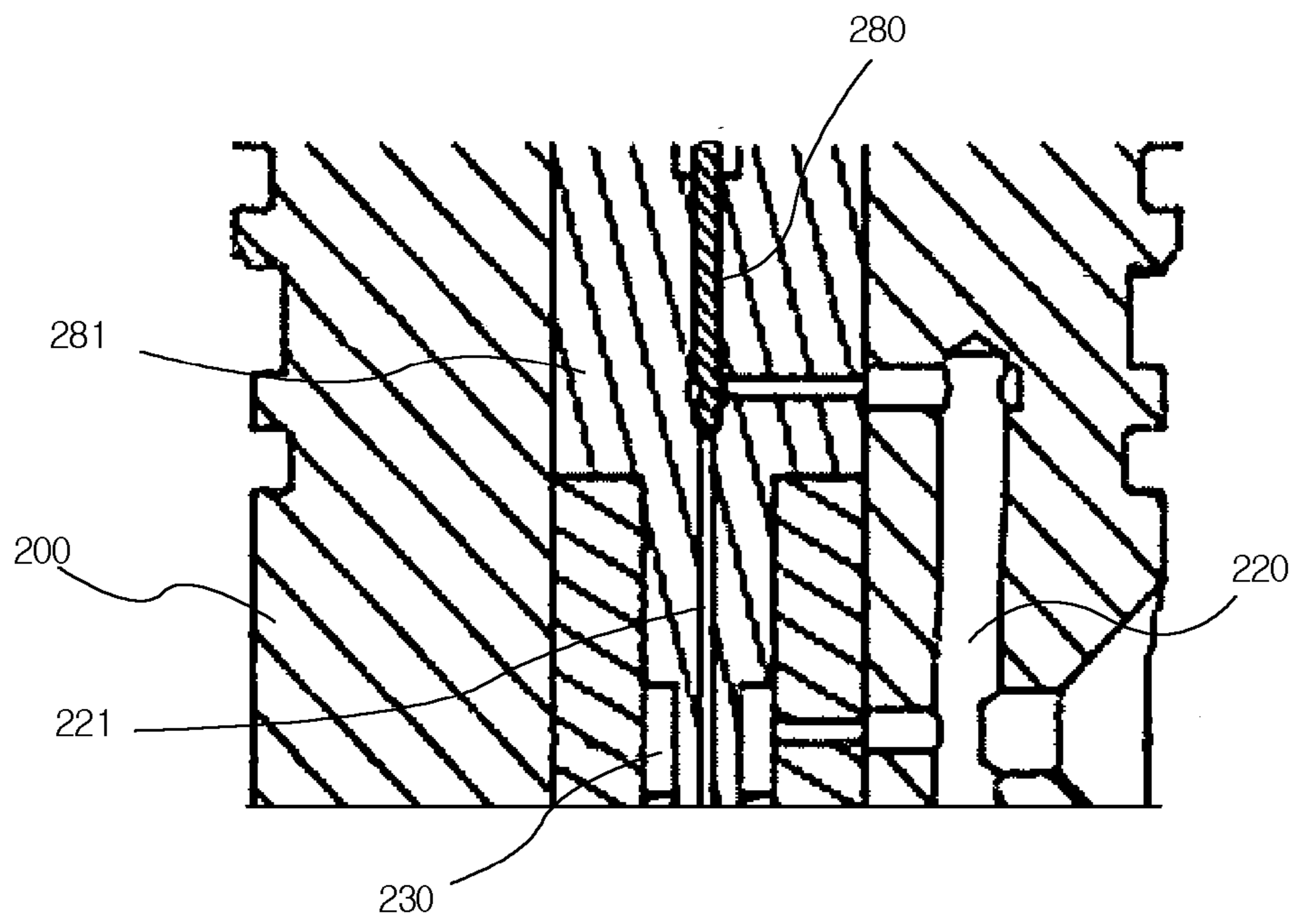

FIG. 8

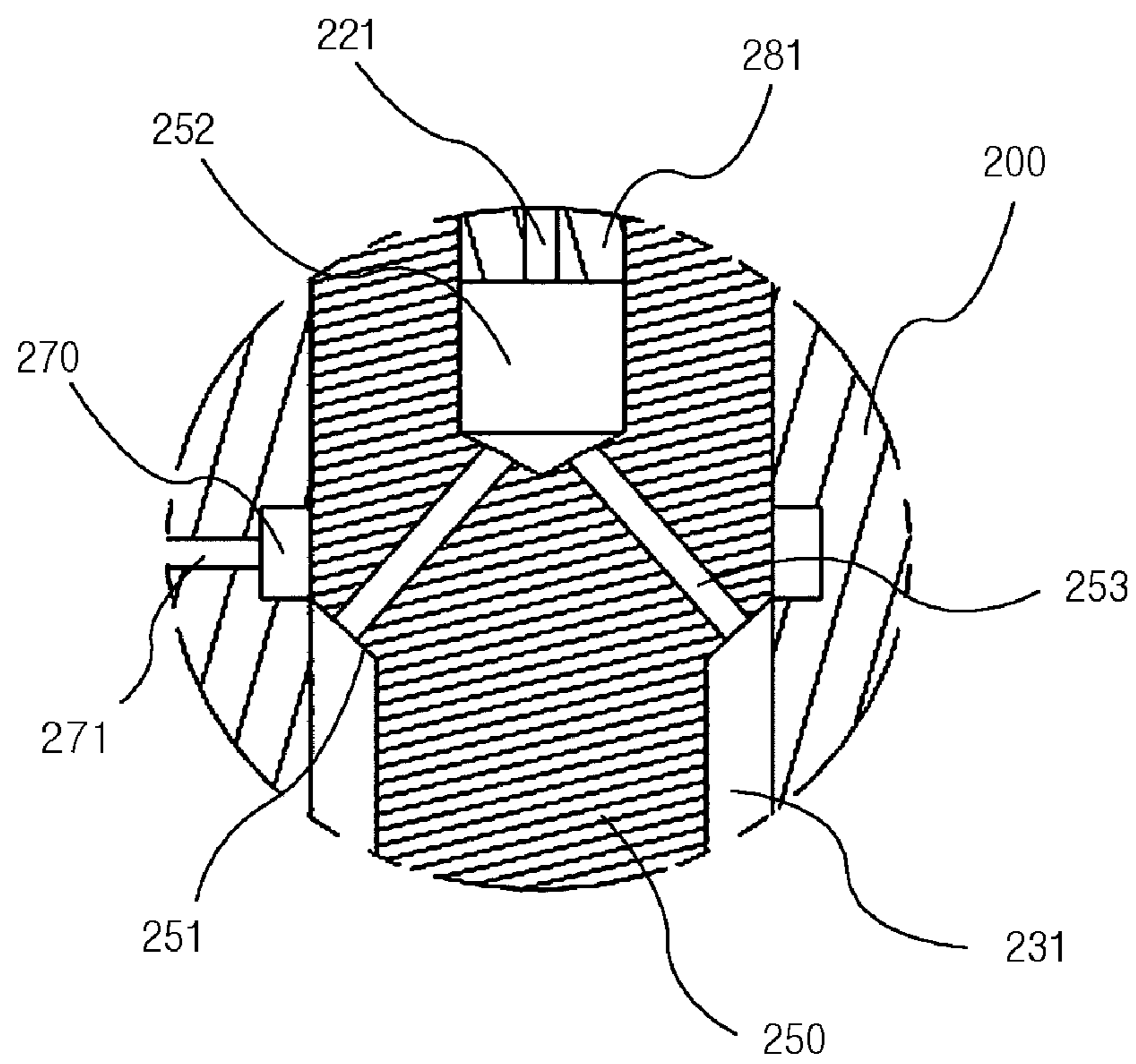

FIG. 9

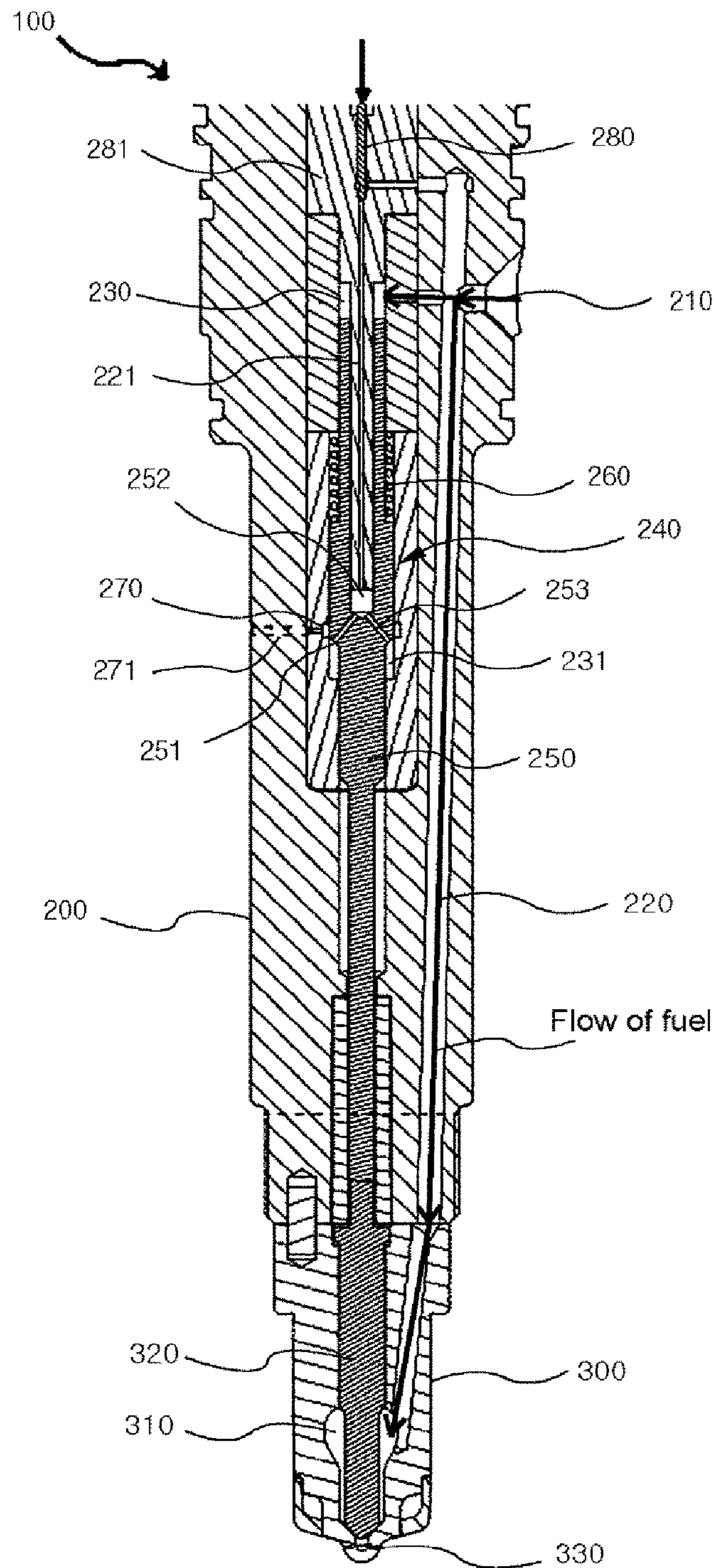

FIG. 10

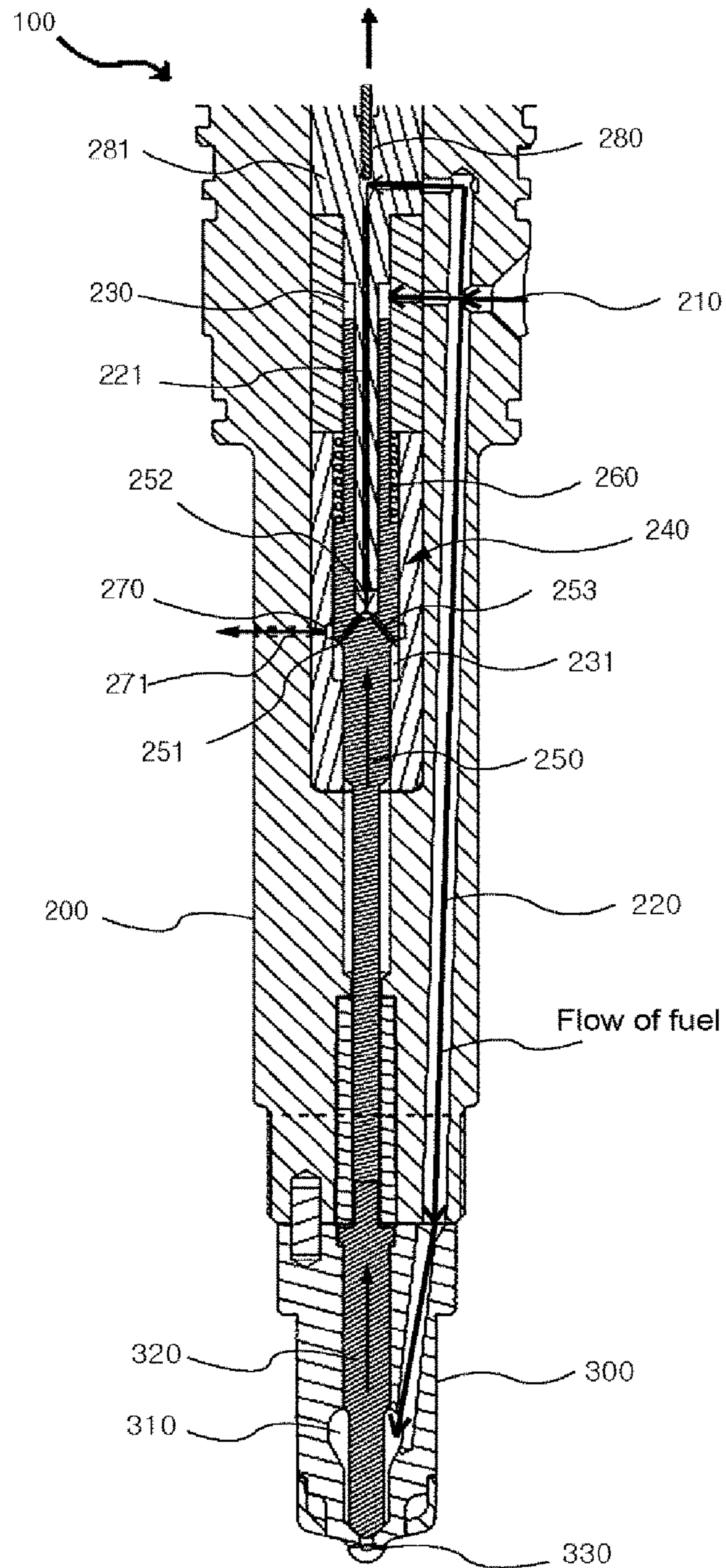

FIG. 11

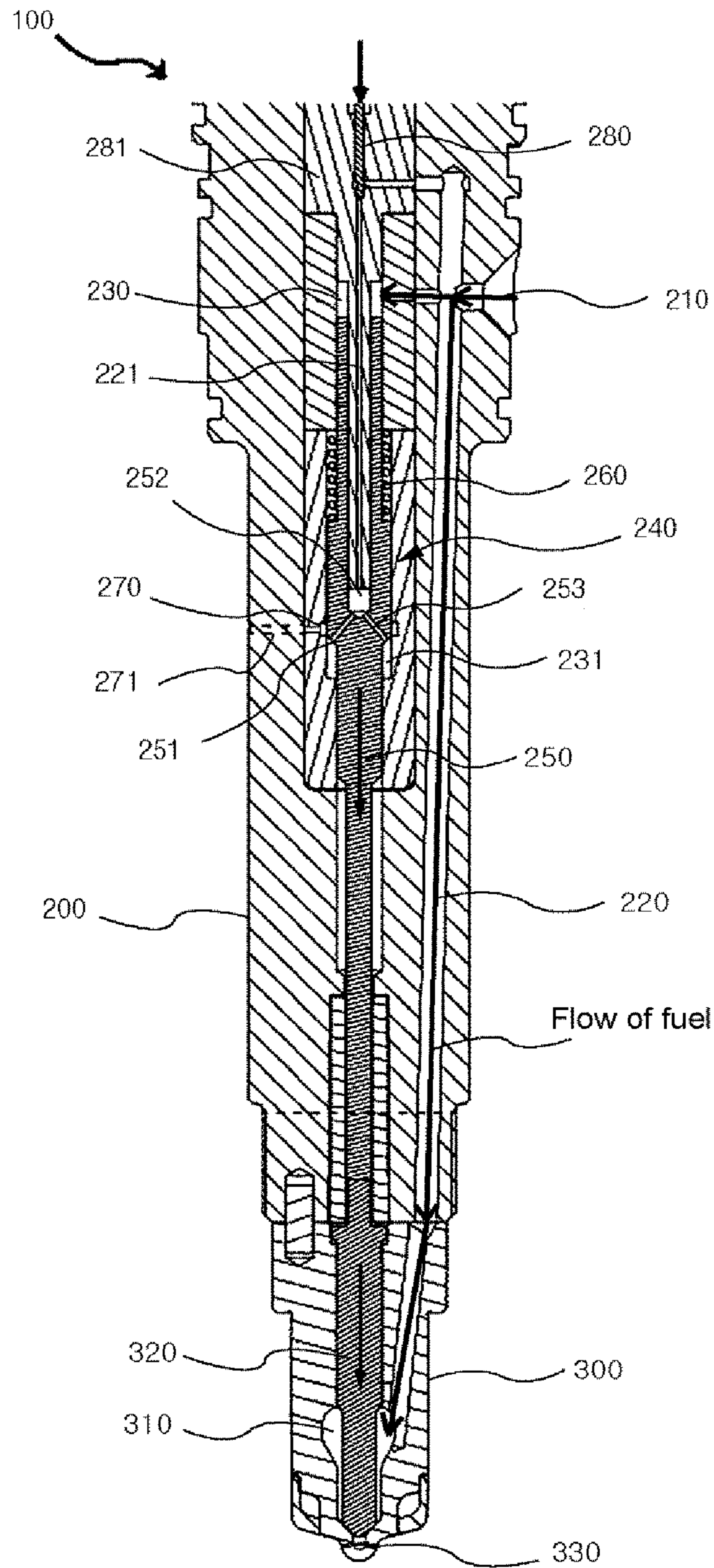

FIG. 12

1

ELECTRONICALLY CONTROLLED FUEL INJECTION VALVE

TECHNICAL FIELD

The present invention relates, in general, to an electronically controlled fuel injection valve and, more particularly, to an electronically controlled fuel injection valve which can independently control the time to inject fuel and the amount of fuel to be injected in response to a control signal sent from the operating condition of an engine, and when fuel is not injected, prevent a nozzle part from being constantly subjected to high pressure due to the nozzle part being not supplied with fuel.

BACKGROUND ART

In response to the development of electronic control technologies, it is the rapidly-growing trend to electronically control engines. Fuel injection methods using a common rail are being widely applied to electronically controlled engines since fuel injection can be performed under high pressure even with a low load and can be easily performed in response to a control signal.

A variety of research and development is being performed on electronically controlled fuel injection valves that are key devices of common rail fuel injection systems. In order to improve the performance of the fuel injection valve, a large number of patent applications are being filed for various types of fuel injection valve driving mechanisms.

A traditional mechanical fuel injection valve is configured such that fuel is injected by lifting up a needle using only the pressure of fuel that is fed into a chamber of a nozzle part. Since injection characteristics such as the time to inject fuel and the amount of fuel to be injected are always uniform, control over fuel injection cannot be performed independently from the operating condition of an engine and this can be problematic.

DISCLOSURE

Technical Problem

Accordingly, the present invention has been made keeping in mind the above problems occurring in the related art, and is intended to provide an electronically controlled fuel injection valve which can control the time to inject fuel and the amount of fuel to be injected in response to a control signal independently from the operating condition of an engine unlike a traditional mechanical fuel injection valve, which employs a control method for fuel injection that increases the force of lifting up a cutoff needle of an injection controller by delivering high-pressure fuel to a lower pressure chamber via a control needle, thereby rapidly controlling fuel injection, which has a simple structure making it easy to assemble, replace and precisely machine parts, and which has a simple flow path structure which facilitates fabrication.

Technical Solution

In order to accomplish the above objects, the present invention provides an electronically controlled fuel injection valve that includes: a valve body having defined therein a first flow path along which fuel is fed through a fuel supply port, and having a control valve housing in an upper portion thereof; a nozzle part coupled to a lower portion of the valve body, and having defined therein a nozzle chamber which is filled with

2

fuel that is supplied via the first flow path so that a needle disposed therein is pressed upward, whereby the needle is lifted up so that fuel is injected; a needle driving part disposed inside the valve body, the needle driving part driving the needle of the nozzle part; an upper pressure chamber formed above the needle driving part, the upper pressure chamber creating a pressure when the upper pressure chamber is filled with fuel fed through the fuel supply port, the pressure pressing the needle driving part in a downward direction; a lower pressure chamber positioned below the upper pressure chamber, the lower pressure chamber creating a pressure when the lower pressure chamber is filled up with fuel, the pressure pressing the needle driving part in an upward direction; a second flow path formed inside the valve body via the control valve housing, the second flow path being connected to the lower pressure chamber, such that fuel can be supplied the lower pressure chamber; a control needle disposed in the control valve housing, the control needle opening and closing the second flow path in response to a control signal, thereby controlling a flow rate of fuel that is supplied to the lower pressure chamber; a control chamber formed in the valve body so as to be connected to the lower pressure chamber, such that the control chamber is filled with fuel from the lower pressure chamber 231 when fuel is discharged; and a control orifice connected to the control chamber, and allows fuel inside the control chamber to be discharged out of the valve body.

In addition, the needle driving part may include: a spindle disposed inside the valve body such that the spindle can drive the needle of the nozzle part; a pressure piston disposed above the spindle, the pressure piston applying a downward force to the spindle under a pressure of fuel that fills the upper pressure chamber; and a spring disposed so as to be inserted into the pressure piston, the spring applying a downward force to the spindle.

In order to accomplish the above objects, the present invention also provides an electronically controlled fuel injection valve that includes: a valve body having defined therein a first flow path along which fuel is fed through a fuel supply port, and having a control valve housing in an upper portion thereof; a nozzle part coupled to a lower portion of the valve body, and having defined therein a nozzle chamber which is filled with fuel that is supplied via the first flow path so that a needle disposed therein is pressed upward, whereby the needle is lifted up so that fuel is injected; a needle driving part disposed inside the valve body, the needle driving part driving the needle of the nozzle part; an upper pressure chamber formed above the needle driving part, the upper pressure chamber creating a pressure when the upper pressure chamber is filled with fuel fed through the fuel supply port, the pressure pressing the needle driving part in a downward direction; a lower pressure chamber positioned below the upper pressure chamber, the lower pressure chamber creating a pressure when the lower pressure chamber is filled up with fuel, the pressure pressing the needle driving part in an upward direction; a second flow path formed inside the needle pressing part via the control valve housing, the second flow path being connected to the lower pressure chamber, such that fuel can be supplied the lower pressure chamber; a control needle disposed in the control valve housing, the control needle opening and closing the second flow path in response to a control signal, thereby controlling a flow rate of fuel that is supplied to the lower pressure chamber; a control chamber formed in the valve body so as to be connected to the lower pressure chamber, such that the control chamber is filled with fuel from the lower pressure chamber when fuel is discharged; and a control orifice connected to the control cham-

3

ber, and allows fuel inside the control chamber to be discharged out of the valve body.

In addition, the needle driving part may include: a spindle disposed inside the valve body so as to be positioned in a lower portion of the upper pressure chamber, the spindle applying a downward force to the needle of the nozzle part under a pressure of fuel that fills the upper pressure chamber; and a spring fitted into the spindle, the spring applying a downward force to the spindle.

Furthermore, the spindle may have a pressure acting surface having a stepped shape such that an upward driving force can act in response to a pressure of fuel that fills the lower pressure chamber.

As described above, the present invention has the following useful merits. It is possible to independently control the time to inject fuel and the amount of fuel to be injected in response to a control signal from the operating condition of an engine, unlike a traditional mechanical fuel injection valve. A control method for fuel injection increases the force of lifting up a cutoff needle of an injection controller by delivering high-pressure fuel to a lower pressure chamber via a control needle, thereby rapidly controlling fuel injection. The simplified structure facilitates replacement of parts. Since the spindle and the piston are separately fabricated such that surfaces which require precision machining are minimized, it is possible to facilitate precision machining of parts, thereby reducing fabrication cost. Since the second flow path is formed inside the spindle via the control valve housing, the structure of the flow path connected to the lower pressure chamber is simplified, thereby facilitating machining.

DESCRIPTION OF DRAWINGS

FIG. 1 is an example view showing a fuel injection valve according to a first embodiment of the present invention;

FIG. 2 is an example view specifically showing the installation structure of the control needle of the fuel injection valve according to the first embodiment of the present invention;

FIG. 3 is an example view specifically showing the structure of the spindle and the lower pressure chamber of the fuel injection valve according to the first embodiment of the present invention;

FIG. 4 is an example view showing the operating state and the flow of fuel when fuel is not injected in response to closing of the control needle of the fuel injection valve according to the first embodiment of the present invention;

FIG. 5 is an example view showing the operating state and the flow of fuel when fuel is injected in response to opening of the control needle of the fuel injection valve according to the first embodiment of the present invention;

FIG. 6 is an example view showing the operating state and the flow of fuel when fuel injection is completed in response to re-closing of the control needle of the fuel injection valve according to the first embodiment of the present invention;

FIG. 7 is an example view showing a fuel injection valve according to a second embodiment of the present invention;

FIG. 8 is an example view specifically showing the installation structure of the control needle of the fuel injection valve according to the second embodiment of the present invention;

FIG. 9 is an example view specifically showing the structure of the spindle and the lower pressure chamber of the fuel injection valve according to the second embodiment of the present invention;

FIG. 10 is an example view showing the operating state and the flow of fuel when fuel is not injected in response to closing

4

of the control needle of the fuel injection valve according to the second embodiment of the present invention;

FIG. 11 is an example view showing the operating state and the flow of fuel when fuel is injected in response to opening of the control needle of the fuel injection valve according to the second embodiment of the present invention; and

FIG. 12 is an example view showing the operating state and the flow of fuel when fuel injection is completed in response to re-closing of the control needle of the fuel injection valve according to the second embodiment of the present invention.

<Description of the Reference Numerals in the Drawings>

100: fuel injection valve	200: valve body
210: fuel supply port	220: first flow path
221: second flow path	230: upper pressure chamber
231: lower pressure chamber	
240: needle driving part	250: spindle
251: pressure acting surface	
252: insertion hole	253: connection hole
260: pressure piston	261: spring
270: control chamber	271: control orifice
280: control needle	281: control valve housing
300: nozzle part	310: nozzle chamber
320: needle	330: nozzle hole

Mode for Invention

Reference will now be made in detail to embodiments of the present invention and their functions in conjunction with the accompanying drawings. In the following description of the present invention, detailed descriptions of known functions and components incorporated herein will be omitted when they may make the subject matter of the present invention unclear.

FIG. 1 is an example view showing a fuel injection valve according to a first embodiment of the present invention, FIG. 2 is an example view specifically showing the installation structure of the control needle of the fuel injection valve according to the first embodiment of the present invention, FIG. 3 is an example view specifically showing the structure of the spindle and the lower pressure chamber of the fuel injection valve according to the first embodiment of the present invention, FIG. 4 is an example view showing the operating state and the flow of fuel when fuel is not injected in response to closing of the control needle of the fuel injection valve according to the first embodiment of the present invention, FIG. 5 is an example view showing the operating state and the flow of fuel when fuel is injected in response to opening of the control needle of the fuel injection valve according to the first embodiment of the present invention, and FIG. 6 is an example view showing the operating state and the flow of fuel when fuel injection is completed in response to re-closing of the control needle of the fuel injection valve according to the first embodiment of the present invention.

As shown in the figures, the fuel injection valve 100 according to the present invention includes a valve body 200, a nozzle part 300, a needle driving part 240, an upper pressure chamber 230, a lower pressure chamber 231, a second flow path 221, a control needle 280, a control chamber 270 and a control orifice 271. The valve body 200 has defined therein a first flow path 220 along which fuel is fed through a fuel supply port 210, and has a control valve housing 281 in the upper portion thereof. The nozzle part 300 is coupled to the lower portion of the valve body 200, and has defined therein a nozzle chamber 310 which is filled with fuel that is supplied via the first flow path 220 so that a needle 320 disposed therein is pressed upward, whereby the needle 320 is lifted up so that fuel is injected toward a nozzle hole 330. The needle driving

part **240** is disposed inside the valve body **200**, and drives the needle **320** of the nozzle part **300**. The upper pressure chamber **230** is formed above the needle driving part **240**, and causes a pressure to form when it is filled with fuel fed through the fuel supply port **210**, the pressure moving the needle driving part **240** in the downward direction. The lower pressure chamber **231** is positioned below the upper pressure chamber **230**, and causes a pressure to form when it is filled up with fuel, the pressure pressing the needle driving part **240** in the upward direction. The second flow path **221** is formed inside the valve body **200** via the control valve housing **281**, and is connected to the lower pressure chamber **231**, such that the lower pressure chamber **231** can be filled with fuel that is supplied through the fuel supply port **210**. The control needle **280** is disposed in the control valve housing **281**, and opens and closes the second flow path **221** in response to a control signal, thereby controlling the flow rate of fuel that is supplied to the lower pressure chamber **231**. The control chamber **270** is formed in the valve body **200** so as to be connected to the lower pressure chamber **231**, such that it is filled with fuel from the lower pressure chamber **231** when fuel is discharged. The control orifice **271** is formed in the valve body **200** so as to be connected to the control chamber **270**, and allows fuel that has filled inside the control chamber **270** to be discharged out of the valve body **200**.

The control needle **280** is configured such that it can be actuated by an actuator (not shown) which operates in response to a control signal so as to open and close the second flow path **221**, thereby controlling the flow rate of fuel that flows into the lower pressure chamber **231**.

In the meantime, the needle driving part **240** includes a spindle **250**, a pressure piston **260** and a spring **261**. The spindle **250** is disposed inside the valve body **200** such that it can drive the needle **320** of the nozzle part **300**. The pressure piston **260** is disposed above the spindle **250**, and applies a downward force to the spindle **250** under the pressure of fuel that fills the upper pressure chamber **230**. The spring **261** is disposed such that it is inserted into the pressure piston **260**, and applies a downward force to the spindle **250**.

In the first embodiment of the present invention, since the spindle **250** and the pressure piston **350** are separately provided, it is easy to adjust the intervals from the spindle **250** and the pressure piston **260** which require precision machining to the inner circumference of the valve body **200**, and thus fabrication cost for the valve is reduced.

That is, the interval between the spindle **250** and the inner circumference of the valve body **200** and the interval between the pressure piston **260** and the inner circumference of the valve body **200** must be precisely machined to a very small size in order to prevent high-pressure fuel that fills the inside of the upper pressure chamber **230** and the lower pressure chamber **231** from leaking through the intervals. When the spindle **250** and the pressure piston **260** are formed integrally, machining is difficult since one part has a large number of surfaces that must be precisely machined. In contrast, the first embodiment of the present invention is designed such that the surfaces of each part that require precision machining are minimized by separately configuring the spindle **250** and the pressure piston **260**. This consequently leads to an advantage in that it becomes easy to precisely machine the parts.

In addition, a pressure acting surface **251** having a stepped shape is formed on the spindle **250** such that a driving force can act in the upward direction in response to the pressure of fuel that fills the lower pressure chamber **231**.

In addition, the control chamber **277** and the control orifice **271** are formed such that they are connected to the lower pressure chamber **231** to discharge fuel inside the lower pres-

sure chamber **231** out of the valve body **200** when the spindle **250** is actuated in the upward direction. In contrast, when the spindle **250** is not actuated, the control chamber **277** and the control orifice **271** are disconnected from the lower pressure chamber **231** so that fuel is not discharged.

A description will be given of the operating state of the fuel injection valve having the above-described configuration according to the first embodiment of the present invention.

First, when fuel is not injected, high-pressure fuel that is supplied through the fuel supply port **210** fills the nozzle chamber **310** of the nozzle part **300** through the upper pressure chamber **230** which is formed above the pressure piston **350** and through the first flow path **220**.

During the standby period in which fuel is not injected as such, fuel is not delivered to the lower pressure chamber **231** through the second flow path **221** since the control needle **280** stays closing the second flow path **221**.

Then, the total of a force that acts in the downward direction on the upper portion of the pressure piston **260** under the pressure of fuel that has filled the upper pressure chamber **230** and a force from the spring **261** that acts in the downward direction is greater than a force acting in the upward direction on the needle **320** of the nozzle part **300** that is caused by the pressure that fills the nozzle chamber **310**. Consequently, the needle **320** stays closed, whereby fuel is not injected through the nozzle hole **330**.

When starting fuel injection, as the actuator operates in response to a control signal to lift up the control needle **280**, the second flow path **221** which has been closed by the control needle **280** is opened, thereby allowing high-pressure fuel to be delivered to the lower pressure chamber **231**. The pressure of fuel that fills the lower pressure chamber **231** acts on the pressure acting surface **251** of the spindle **320**.

Accordingly, as the force for pushing the spindle **250** and the needle **320** of the needle **320** in the upward direction under the pressure of acting on the needle **320** caused by fuel that has filled up the nozzle chamber **310** of the nozzle **300** and the pressure acting on the spindle **250** caused by fuel that is filling the lower pressure chamber **231** becomes greater than the total of the force that fills the upper pressure chamber **230** and acts on the upper portion of the pressure piston **260** and the force from the spring **261** that acts in the downward direction, the spindle **250** and the needle **320** of the nozzle part **300** are lifted up, whereby fuel is injected through the nozzle hole **330**.

When completing fuel injection, the control needle **280** moves downward in response to a control signal, thereby closing the second path **221** which is connected to the lower pressure chamber **231**.

When the second flow path **221** is closed as such, fuel is no longer supplied to the lower pressure chamber **231** but is discharged through control orifice **270**, so that the pressure inside the lower pressure chamber **231** decreases.

Then, the force for lifting up the spindle **320** and the needle **320** of the nozzle part **300** caused by the pressure of fuel becomes smaller than the total of the force for pressing down the spindle **250** and the needle **320** of the nozzle part **300** caused by the pressure that acts on the upper portion of the pressure piston **260** and the force from the spring **261**. Consequently, the needle **320** of the nozzle part **300** moves downward to close the flow path, thereby completing fuel injection through the nozzle hole **330**.

In the fuel injection valve according to the first embodiment of the present invention as described above, the control needle **280** can operate in response to a control signal to control the time to inject fuel and the amount of fuel to be

injected independently from the operating condition of an engine unlike the traditional mechanical fuel injection valve.

In addition, a control method for fuel injection is to increase the force of lifting up the needle **320** of the nozzle part **300** by delivering high-pressure fuel to the lower pressure chamber **231** via the control needle **280**, so that control over fuel injection can be rapidly performed.

Furthermore, the spindle **250** and the pressure piston **260** are designed such that they are separately fabricated such that surfaces of each part which require precision machining are minimized. This leads to an advantage in that precision machining of parts is easy.

In addition, parts can be easily assembled and replaced due to the simple structure. In particular, there is an advantage in that the nozzle part can be easily replaced.

FIG. 7 is an example view showing a fuel injection valve according to a second embodiment of the present invention, FIG. 8 is an example view specifically showing the installation structure of the control needle of the fuel injection valve according to the second embodiment of the present invention, FIG. 9 is an example view specifically showing the structure of the spindle and the lower pressure chamber of the fuel injection valve according to the second embodiment of the present invention, FIG. 10 is an example view showing the operating state and the flow of fuel when fuel is not injected in response to closing of the control needle of the fuel injection valve according to the second embodiment of the present invention, FIG. 11 is an example view showing the operating state and the flow of fuel when fuel is injected in response to opening of the control needle of the fuel injection valve according to the second embodiment of the present invention, and FIG. 12 is an example view showing the operating state and the flow of fuel when fuel injection is completed in response to re-closing of the control needle of the fuel injection valve according to the second embodiment of the present invention.

As shown in the figures, the fuel injection valve **100** according to the second embodiment of the present invention includes a valve body **200**, a nozzle part **300**, a needle driving part **240**, an upper pressure chamber **230**, a lower pressure chamber **231**, a second flow path **221**, a control needle **280**, a control chamber **270** and a control orifice **271**. The valve body **200** has defined therein a first flow path **220** along which fuel is fed through a fuel supply port **210**, and has a control valve housing **281** in the upper portion thereof. The nozzle part **300** is coupled to the lower portion of the valve body **200**, and has defined therein a nozzle chamber **310** which is filled with fuel that is supplied via the first flow path **220** so that a needle **320** disposed therein is pressed upward, whereby the needle **320** is lifted up so that fuel is injected toward a nozzle hole **330**. The needle driving part **240** is disposed inside the valve body **200**, and drives the needle **320** of the nozzle part **300**. The upper pressure chamber **230** is formed above the needle driving part **240**, and creates a pressure when it is filled with fuel fed through the fuel supply port **210**, the pressure moving the needle driving part **240** in the downward direction. The lower pressure chamber **231** is positioned below the upper pressure chamber **230**, and creates a pressure when it is filled up with fuel, the pressure pressing the needle driving part **240** in the upward direction. The second flow path **221** is formed inside the needle driving part **240** via the control valve housing **281**, and is connected to the lower pressure chamber **231** such that fuel can be supplied the lower pressure chamber **231**. The control needle **280** is disposed in the control valve housing **281**, and opens and closes the second flow path **221** in response to a control signal, thereby controlling the flow rate of fuel that is supplied to the lower pressure chamber **231**. The

control chamber **270** is formed in the valve body **200** so as to be connected to the lower pressure chamber **231**, such that it is filled with fuel from the lower pressure chamber **231** when fuel is discharged. The control orifice **271** is formed in the valve body **200** so as to be connected to the control chamber **270**, and allows fuel that has filled inside the control chamber **270** to be discharged out of the valve body **200**.

The control needle **280** is configured such that it can be actuated by an actuator (not shown) which operates in response to a control signal so as to open and close the second flow path **221**, thereby controlling the flow rate of fuel that flows into the lower pressure chamber **231**.

The needle driving part **240** includes a spindle **250** and a spring **261**. The spindle **250** is disposed inside the valve body **200** such that it is positioned in the lower portion of the upper pressure chamber **230**, and applies a downward force to the needle **320** of the nozzle part **300** under the pressure of fuel that fills the upper pressure chamber **230**. The spring **261** is fitted into the spindle **250**, and applies a downward force to the spindle **250**.

The spindle **250** has an insertion hole **252** into which the control valve housing **281** can be inserted.

Since the control valve housing **281** in which the second flow path **221** is formed is inserted into and coupled to the insertion hole **252**, the second flow path **221** is positioned inside the spindle **250**. Consequently, the second flow path **221** has a simple structure, and thus can be easily machined.

In addition, a plurality of connection holes **253** is formed in the insertion hole **252**. The connection holes **253** are connected to the lower pressure chamber **231** such that fuel that feeds through the second flow path **221** can be supplied to the lower pressure chamber **231** which is formed outside the spindle **250**.

In addition, a pressure acting surface **251** which has a stepped shape is formed on the spindle **250** such that a driving force can act in the upward direction in response to the pressure of fuel that fills the lower pressure chamber **231**.

In addition, the control chamber **277** and the control orifice **271** are formed such that they are connected to the lower pressure chamber **231** to discharge fuel inside the lower pressure chamber **231** out of the valve body **200** when the spindle **250** is actuated in the upward direction. In contrast, when the spindle **250** is not actuated, the control chamber **277** and the control orifice **271** are disconnected from the lower pressure chamber **231** so that fuel is not discharged.

A description will be given of the operating state of the fuel injection valve having the above-described configuration according to the second embodiment of the present invention.

First, when fuel is not injected, high-pressure fuel that is supplied through the fuel supply port **210** fills the nozzle chamber **310** of the nozzle part **300** through the upper pressure chamber **230** which is formed above the pressure piston **350** and through the first flow path **220**.

During the standby period in which fuel is not injected as such, fuel is not delivered to the lower pressure chamber **231** through the second flow path **221** since the control needle **280** stays closing the second flow path **221**.

Then, the total of a force that acts in the downward direction on the upper portion of the spindle **250** under the pressure of fuel that has filled the upper pressure chamber **230** and a force from the spring **261** that acts in the downward direction is greater than a force acting in the upward direction on the needle **320** of the nozzle part **300** that is caused by the pressure that fills the nozzle chamber **310**. Consequently, the needle **320** stays closed, whereby fuel is not injected through the nozzle hole **330**.

When starting fuel injection, as the actuator operates in response to a control signal to lift up the control needle **280**, the second flow path **221** which has been closed by the control needle **280** is opened, thereby allowing high-pressure fuel to be delivered to the lower pressure chamber **231** through the connection holes **253** inside the spindle **250**. The pressure of fuel that fills the lower pressure chamber **231** acts on the pressure acting surface **251** of the spindle **320**.

Accordingly, as the force for pushing the spindle **250** and the needle **320** of the nozzle part **300** in the upward direction, under the pressure of acting on the needle **320** caused by fuel that has filled up the nozzle chamber **310** of the nozzle **300** and the pressure acting on the spindle **250** caused by fuel that is filling the lower pressure chamber **231**, becomes greater than the total of the force that fills the upper pressure chamber **230** and acts on the upper portion of the spindle **250** and the force from the spring **261** that acts in the downward direction, the spindle **250** and the needle **320** of the nozzle part **300** are lifted up, whereby fuel is injected through the nozzle hole **330**.

When completing fuel injection, the control needle **280** moves downward in response to a control signal, thereby closing the second path **221** which is connected to the lower pressure chamber **231**.

When the second flow path **221** is closed as such, fuel is no longer supplied to the lower pressure chamber **231** but is discharged through control orifice **270** so that the pressure inside the lower pressure chamber **231** decreases.

Then, the force for lifting up the spindle **320** and the needle **320** of the nozzle part **300** caused by the pressure of fuel becomes smaller than the total of the force for pressing down the spindle **250** and the needle **320** of the nozzle part **300** caused by the pressure that acts on the upper portion of the spindle **250** and the force from the spring **261**. Consequently, the needle **320** of the nozzle part **300** moves downward to close the flow path, thereby completing fuel injection through the nozzle hole **330**.

In the fuel injection valve according to the present invention as described above, the control needle **280** can operate in response to a control signal to control the time to inject fuel and the amount of fuel to be injected independently from the operating condition of an engine unlike the traditional mechanical fuel injection valve.

In addition, a control method for fuel injection is to increase the force of lifting up the needle **320** of the nozzle part **300** by delivering high-pressure fuel to the lower pressure chamber **231** via the control needle **280**, so that control over fuel injection can be rapidly performed.

Furthermore, since the structure of the second flow path is simplified, fabrication is simplified and parts can be easily assembled and replaced.

Although the present invention has been described hereinabove with respect to the certain exemplary embodiments, it should be understood that the present invention is not limited to the foregoing embodiments. It is apparent to a person having ordinary skill in the art to which the present invention belongs that a variety of changes can be made without departing from the concept of the present invention that is defined in the appended claims, and that such changes fall within the scope of the claims.

What is claimed is:

1. An electronically controlled fuel injection valve comprising:

- a valve body having defined therein a first flow path along which fuel is fed through a fuel supply port, and having a control valve housing in an upper portion thereof;
- a nozzle part coupled to a lower portion of the valve body, and having defined therein a nozzle chamber which is filled with fuel that is supplied via the first flow path so that a needle disposed therein is pressed upward, whereby the needle is lifted up so that fuel is injected;
- a needle driving part disposed inside the valve body, the needle driving part driving the needle of the nozzle part;
- an upper pressure chamber formed above the needle driving part, the upper pressure chamber creating a pressure when the upper pressure chamber is filled with fuel fed through the fuel supply port, the pressure pressing the needle driving part in a downward direction;
- a lower pressure chamber positioned below the upper pressure chamber, the lower pressure chamber creating a pressure when the lower pressure chamber is filled up with fuel, the pressure pressing the needle driving part in an upward direction;
- a second flow path formed inside the valve body via the control valve housing, the second flow path being connected to the lower pressure chamber, such that fuel is supplied the lower pressure chamber;
- a control needle disposed in the control valve housing, the control needle opening and closing the second flow path in response to a control signal, thereby controlling a flow rate of fuel that is supplied to the lower pressure chamber;
- a control chamber formed in the valve body so as to be connected to the lower pressure chamber, such that the control chamber is filled with fuel from the lower pressure chamber when fuel is discharged; and
- a control orifice connected to the control chamber, and allows fuel inside the control chamber to be discharged out of the valve body.

2. The electronically controlled fuel injection valve according to claim **1**, wherein the needle driving part comprises:

- a spindle disposed inside the valve body such that the spindle drives the needle of the nozzle part;
- a pressure piston disposed above the spindle, the pressure piston applying a downward force to the spindle under a pressure of fuel that fills the upper pressure chamber; and
- a spring disposed so as to be inserted into the pressure piston, the spring applying a downward force to the spindle.

3. The electronically controlled fuel injection valve according to claim **1**, wherein the spindle has a pressure acting surface having a stepped shape such that an upward driving force acts in response to a pressure of fuel that fills the lower pressure chamber.

4. The electronically controlled fuel injection valve according to claim **2**, wherein the spindle has a pressure acting surface having a stepped shape such that an upward driving force acts in response to a pressure of fuel that fills the lower pressure chamber.