

US009164191B2

(12) **United States Patent**
Dogru

(10) **Patent No.:** **US 9,164,191 B2**
(45) **Date of Patent:** **Oct. 20, 2015**

(54) **SEQUENTIAL FULLY IMPLICIT WELL MODEL FOR RESERVOIR SIMULATION**

(75) Inventor: **Ali H. Dogru**, Dhahran (SA)

(73) Assignee: **Saudi Arabian Oil Company**, Dhahran (SA)

(*) Notice: Subject to any disclaimer, the term of this patent is extended or adjusted under 35 U.S.C. 154(b) by 182 days.

(21) Appl. No.: **13/023,728**

(22) Filed: **Feb. 9, 2011**

(65) **Prior Publication Data**

US 2012/0203518 A1 Aug. 9, 2012

(51) **Int. Cl.**
E21B 43/00 (2006.01)
G01V 99/00 (2009.01)

(52) **U.S. Cl.**
CPC **G01V 99/005** (2013.01); **E21B 43/00** (2013.01)

(58) **Field of Classification Search**
CPC G01V 99/005; G06F 17/5009; G06F 17/5018
USPC 703/2, 10
See application file for complete search history.

(56) **References Cited**

U.S. PATENT DOCUMENTS

4,991,095	A *	2/1991	Swanson	702/16
6,018,497	A *	1/2000	Gunasekera	367/72
6,078,869	A *	6/2000	Gunasekera	702/6
6,106,561	A *	8/2000	Farmer	703/10
7,369,979	B1 *	5/2008	Spivey	703/10
7,627,461	B2 *	12/2009	Guyaguler et al.	703/10
8,285,532	B2 *	10/2012	Zangl et al.	703/10
8,396,699	B2 *	3/2013	Maliassov	703/7

8,805,660	B2 *	8/2014	Guyaguler et al.	703/10
2006/0036418	A1 *	2/2006	Pita et al.	703/10
2006/0235667	A1 *	10/2006	Fung et al.	703/10
2007/0265815	A1 *	11/2007	Couet et al.	703/10
2007/0271077	A1 *	11/2007	Kosmala et al.	703/5
2009/0248378	A1 *	10/2009	Li et al.	703/10
2010/0094605	A1 *	4/2010	Hajibeygi et al.	703/2
2010/0191511	A1	7/2010	Hsu et al.	
2010/0250216	A1 *	9/2010	Narr et al.	703/10
2010/0312535	A1 *	12/2010	Chen et al.	703/10

(Continued)

OTHER PUBLICATIONS

Stern, D., et al. "A Technique for Generating Reservoir Simulation Grids to Preserve Geologic Heterogeneity" SPE 51942 (1999).*

(Continued)

Primary Examiner — Kamini S Shah

Assistant Examiner — Jay B Hann

(74) *Attorney, Agent, or Firm* — Bracewell & Giuliani LLP; Constance G. Rhebergen; Albert B. Kimball, Jr.

(57) **ABSTRACT**

A subsurface hydrocarbon reservoir with wells is simulated by simultaneous solution of reservoir and well equations which simulate flow profiles along a well without requiring an unstructured coefficient matrix for reservoir unknowns. An analytical model of the reservoir is formed using the known or measured bottom hole pressure. Where several layers in an interval in the reservoir are present between vertical flow barriers in the reservoir, and communicate vertically with others, the communicating layers are combined for analytical modeling into a single layer for that interval for simulation purposes. The matrix of equations defining the unknown pressures and saturations of the intervals of combined layers in the reservoir are solved in the computer, and a perforation rate determined for each such interval of combined layers. Rates for the intervals in the reservoir are then combined to determine total well rate.

23 Claims, 14 Drawing Sheets

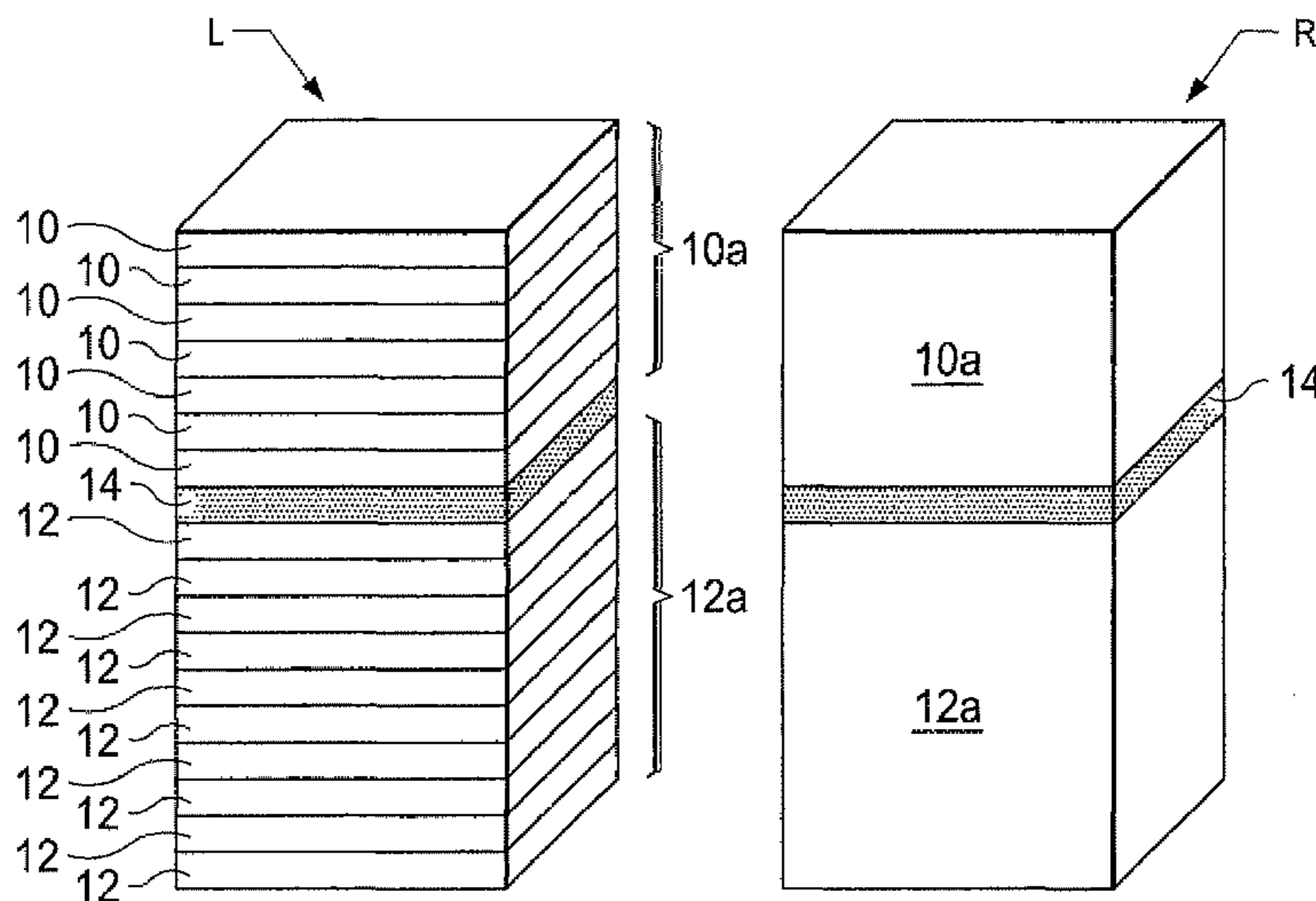

(56)

References Cited

U.S. PATENT DOCUMENTS

2011/0011595	A1	1/2011	Huang et al.	
2011/0015909	A1*	1/2011	Zhao	703/2
2011/0024125	A1	2/2011	Wallace et al.	
2012/0221302	A1*	8/2012	Lewandowski et al.	703/2
2013/0116993	A1*	5/2013	Maliassov	703/2

OTHER PUBLICATIONS

Fung, Larry S.K., et al., A Fully-Implicit Fully-Coupled Well Model for Parallel Mega-Cell Reservoir Simulation SPE Technical Symposium of Saudi Arabia Section, May 14-16, 2005, Dhahran, Saudi Arabia.

Holmes, Jonathan A. et al., "Modeling Advanced Wells in Reservoir Simulation" Journal of Petroleum Technology, vol. 53, No. 11, Nov. 2001.

Coats, K.H., et al., "Compositional and Black Oil Reservoir Simulation" SPE Reservoir Evaluation & Engineering, vol. 1, No. 4, Aug. 1998, pp. 372-379.

Muskat, M., "The Flow of Homogenous Fluids Through Porous Media", 1937, pp. 264-277, Mc-Graw Hill.

Muskat, M., "Physical Principles of Oil-Production", 1949, pp. 204-215, McGraw-Hill.

PCT Int'l Search Report and the Written Opinion dated May 28, 2013; Int'l Application No. PCT/US2012/023284; Int'l Filing Date: Jan. 31, 2012.

* cited by examiner

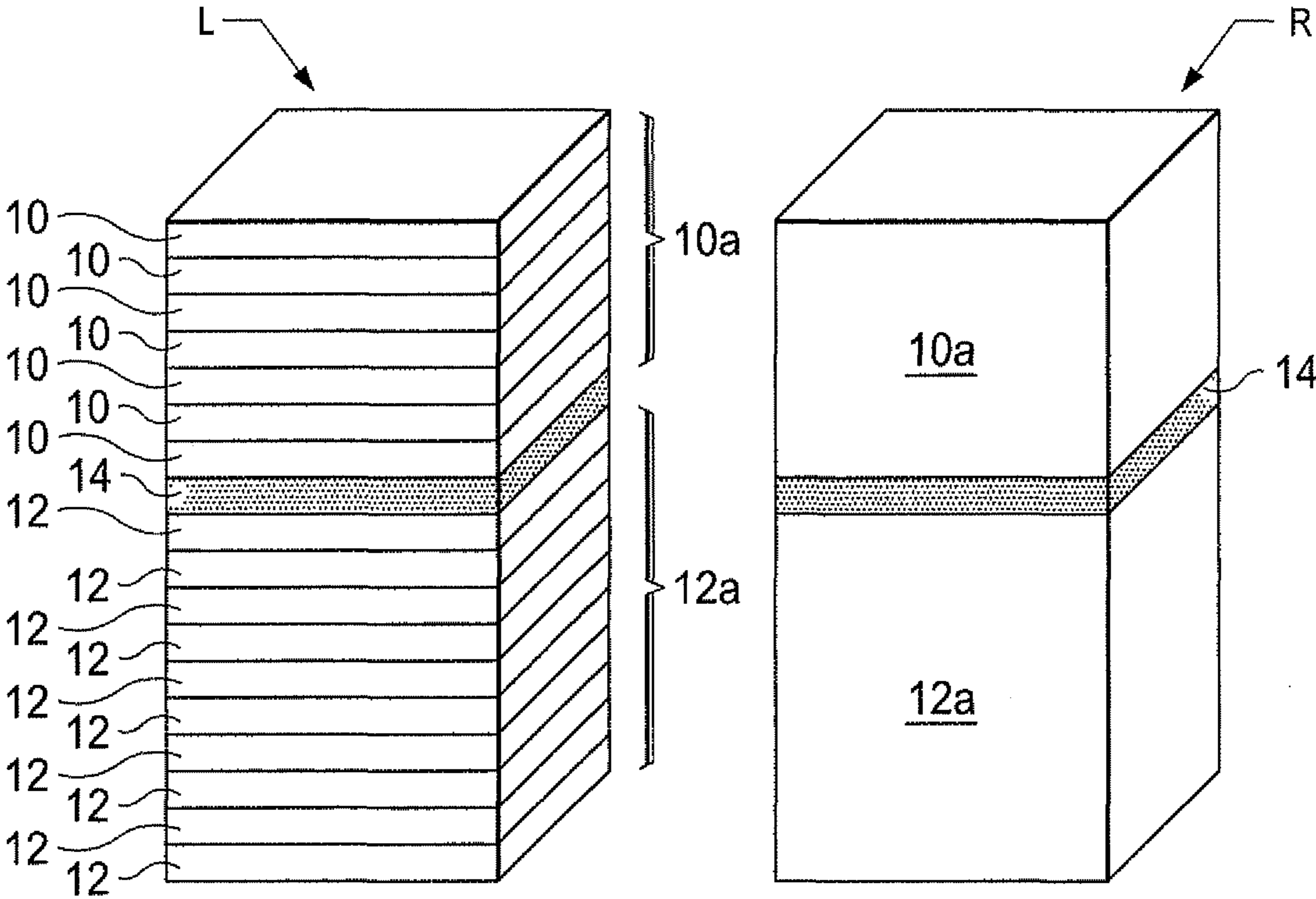

FIG. 1

FIG. 1A

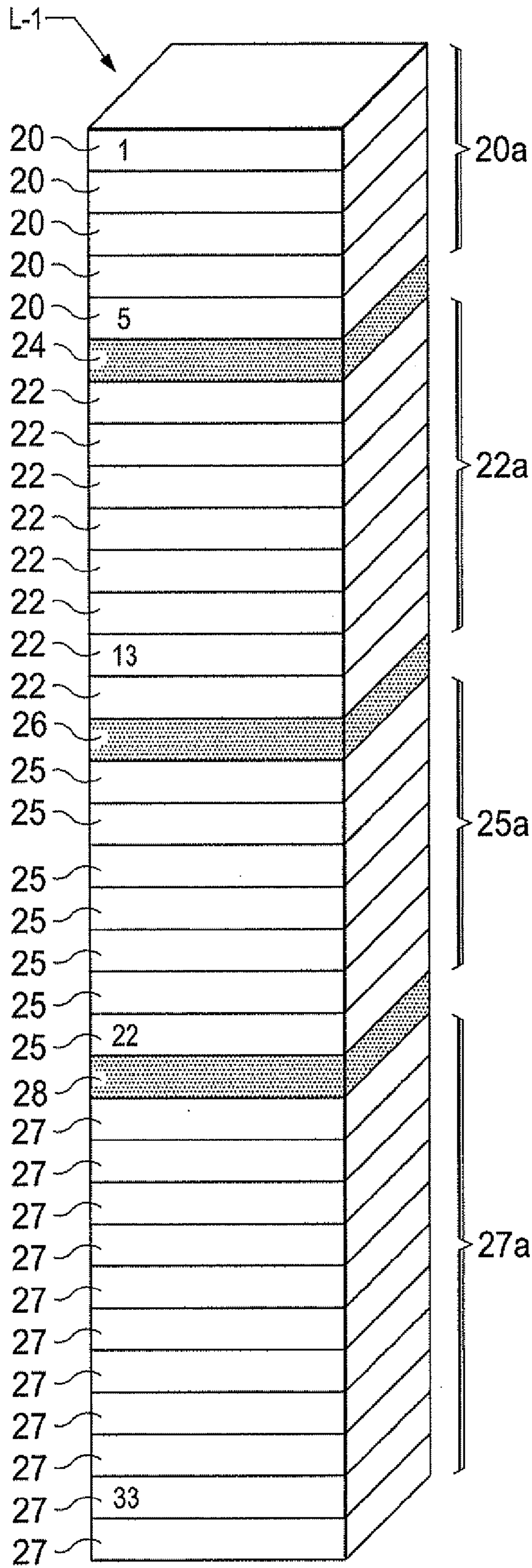

FIG. 2

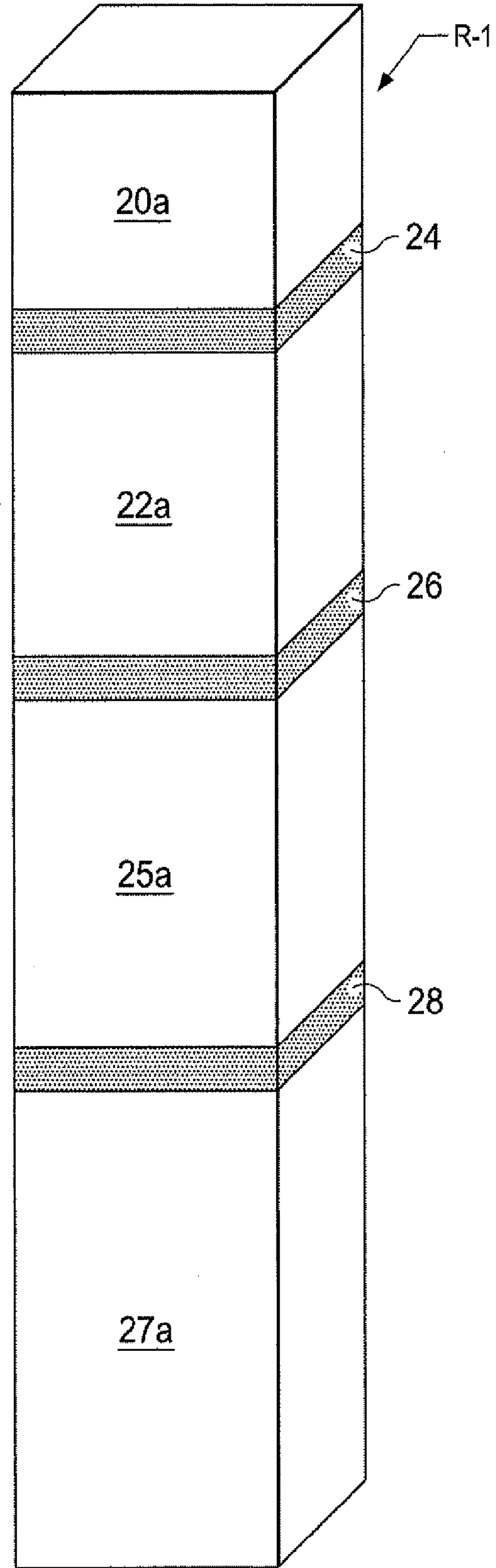

FIG. 2A

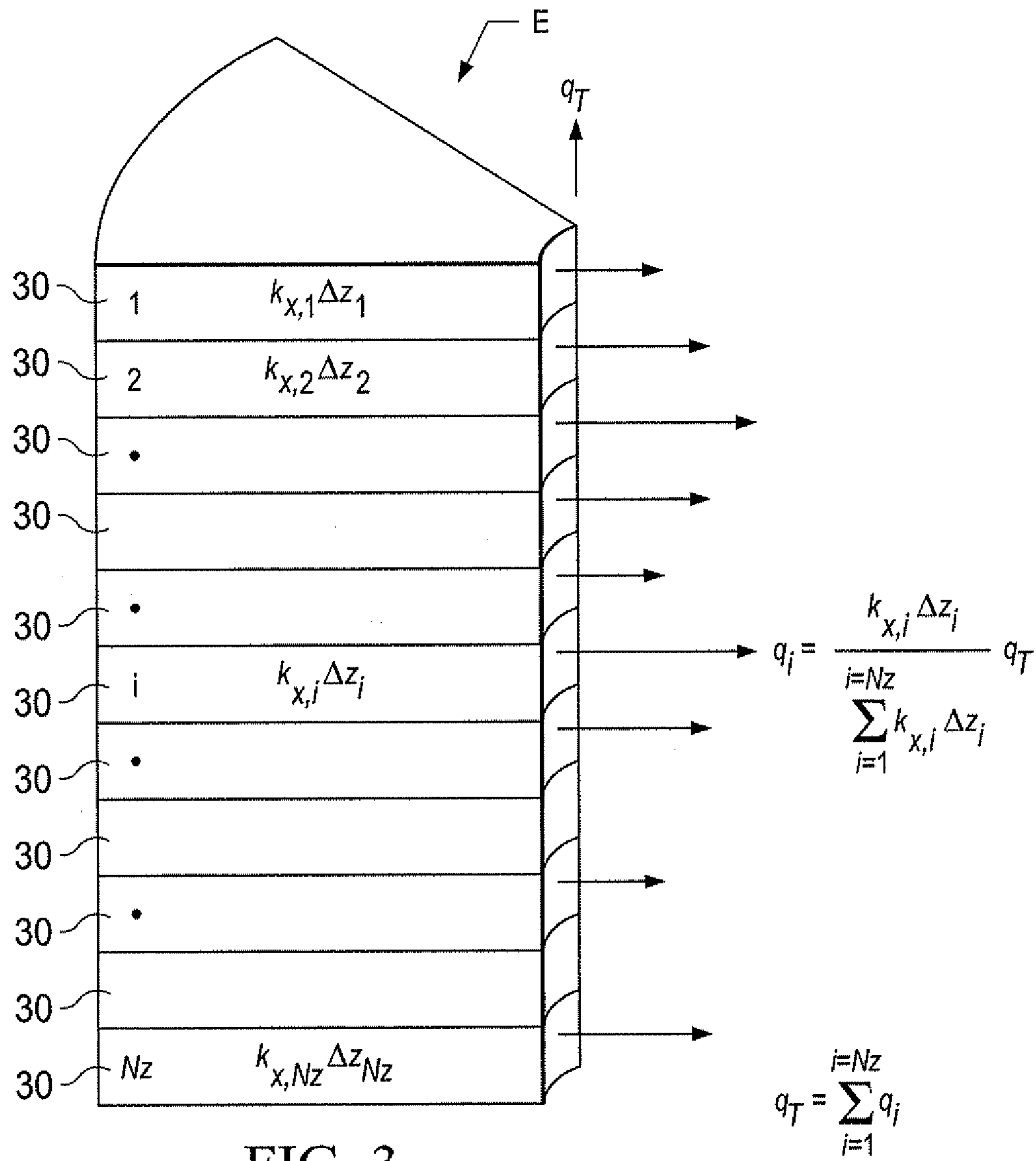

FIG. 3

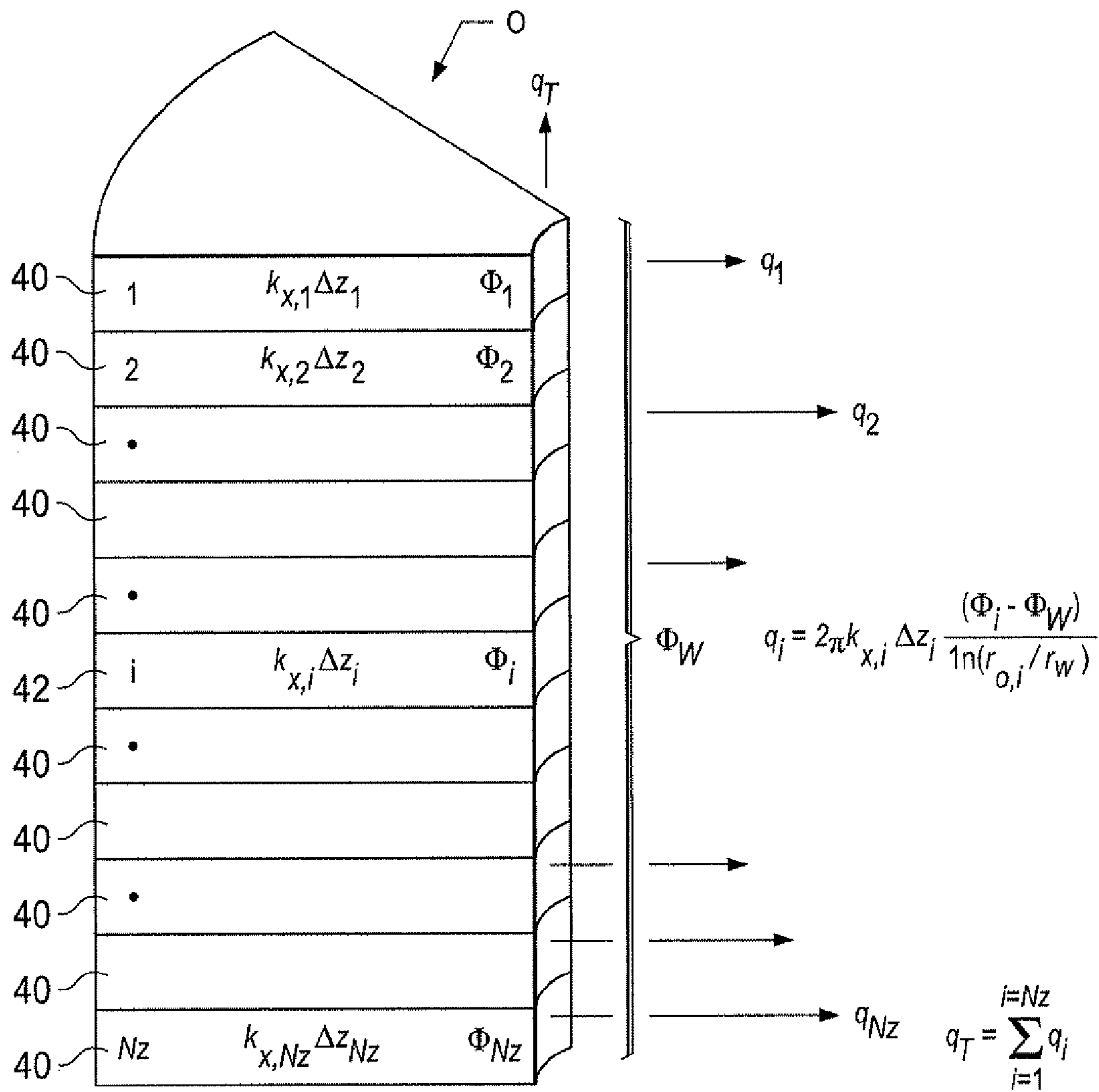

FIG. 4

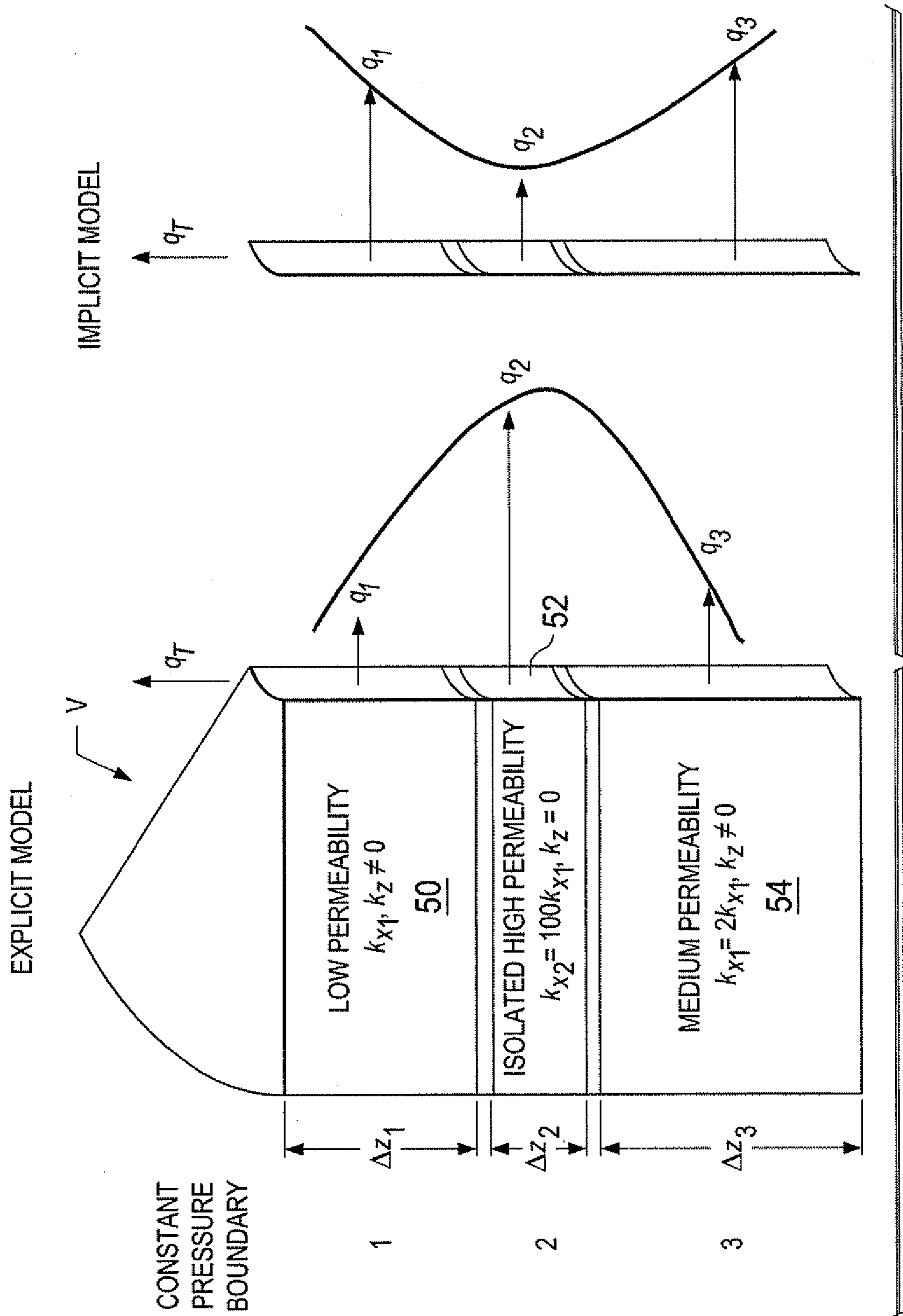

FIG. 5

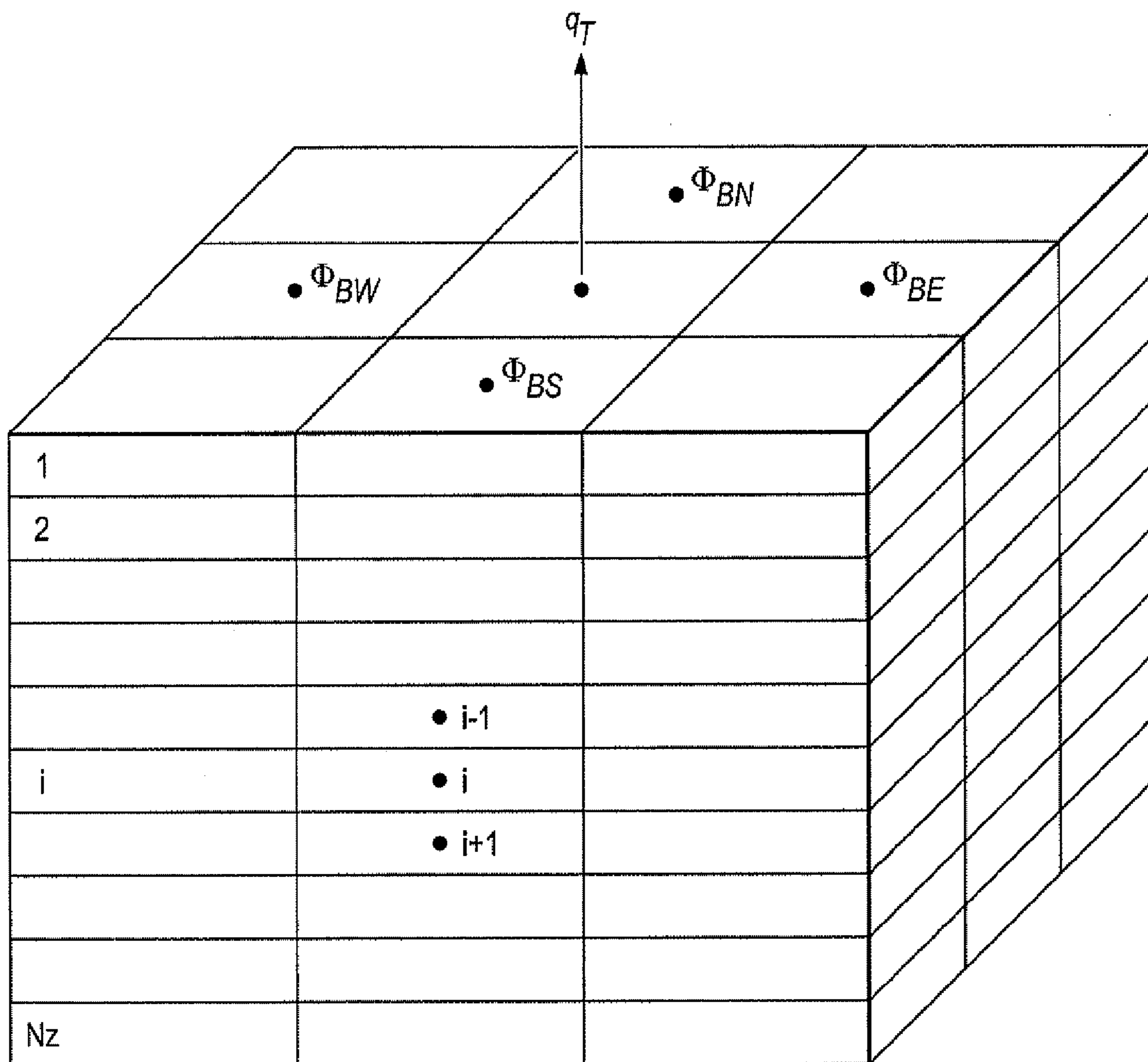

FIG. 6

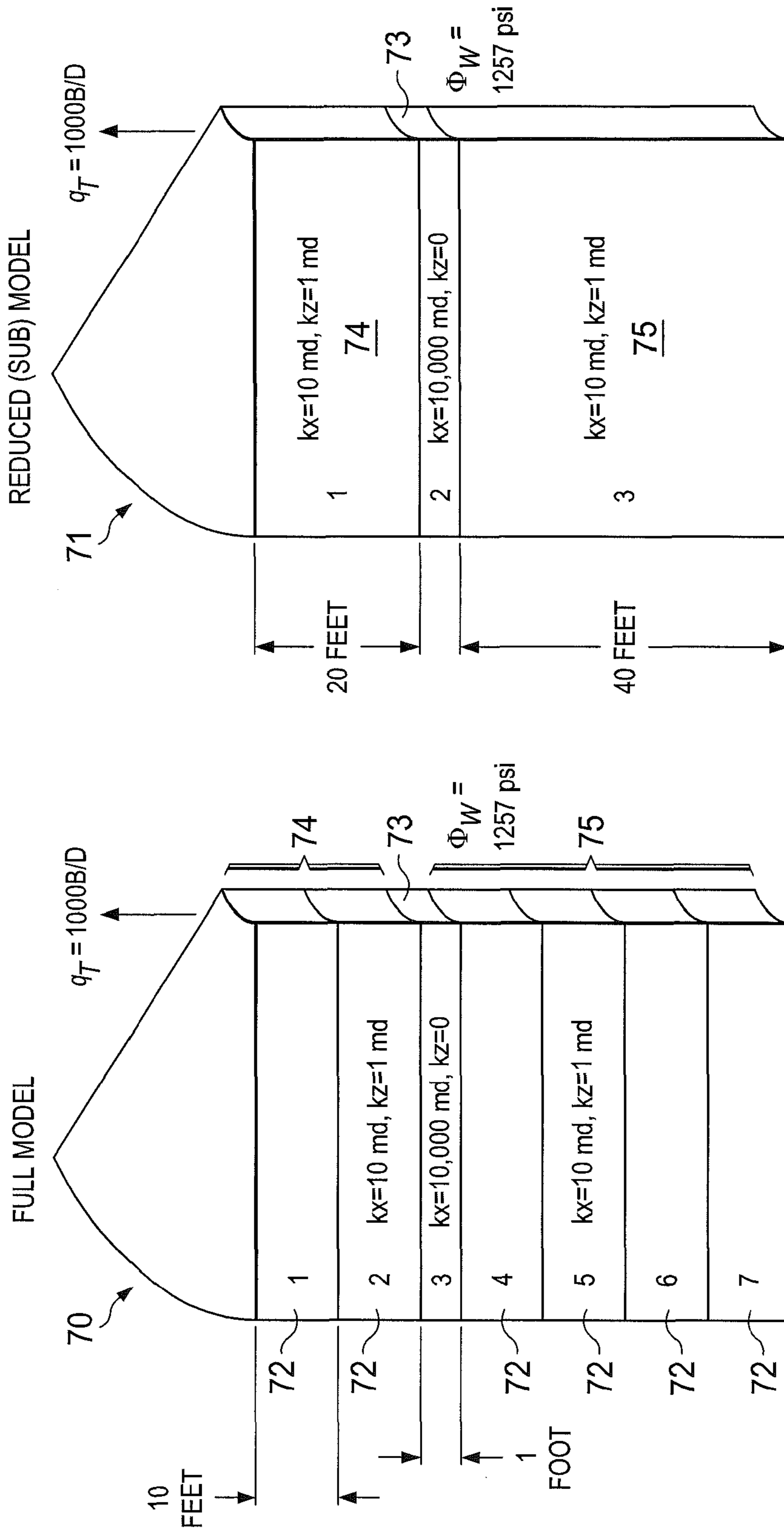

FIG. 7B

FIG. 7A

PRIOR ART

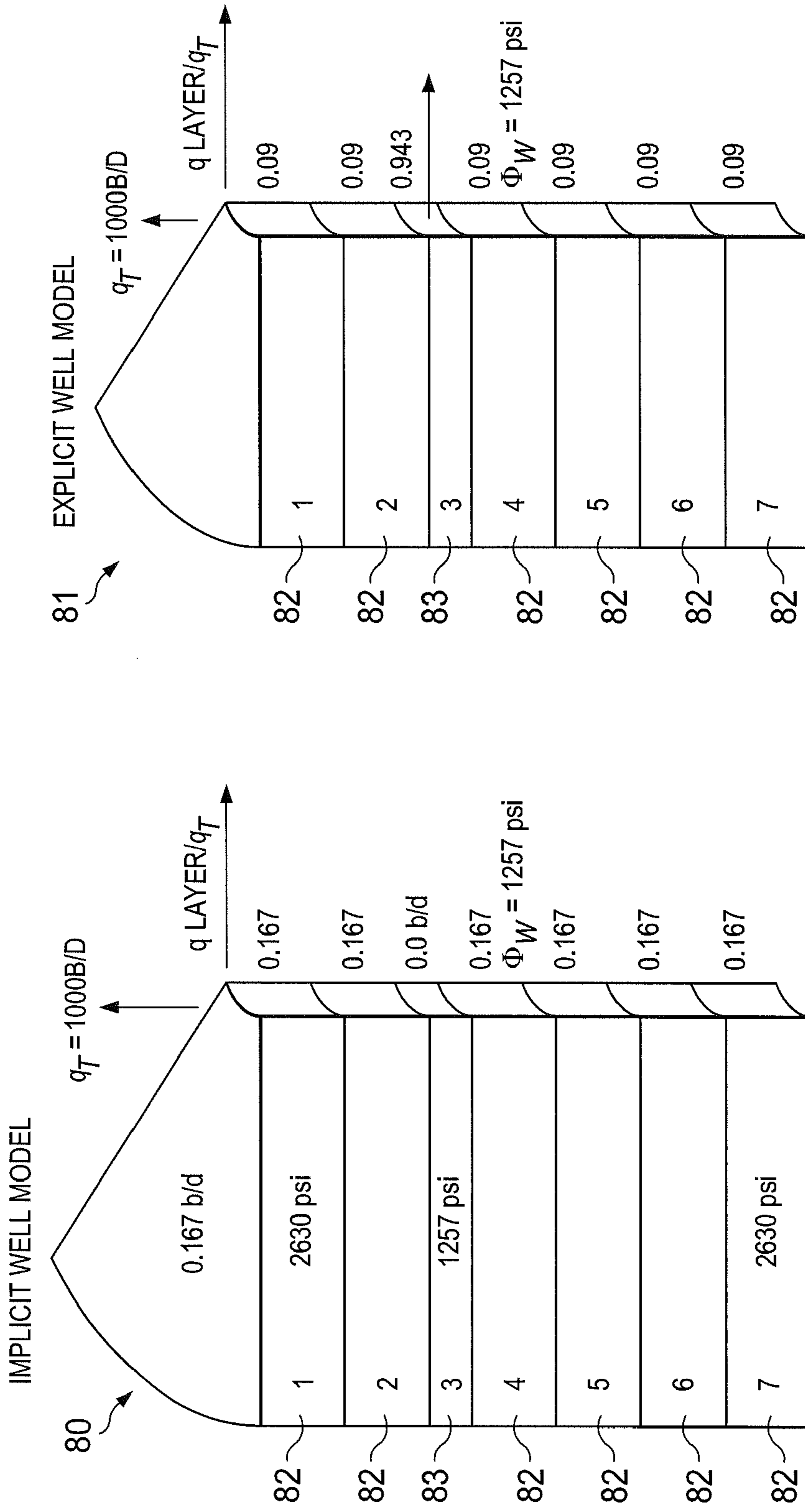

FIG. 8B

FIG. 8A

PRIOR ART

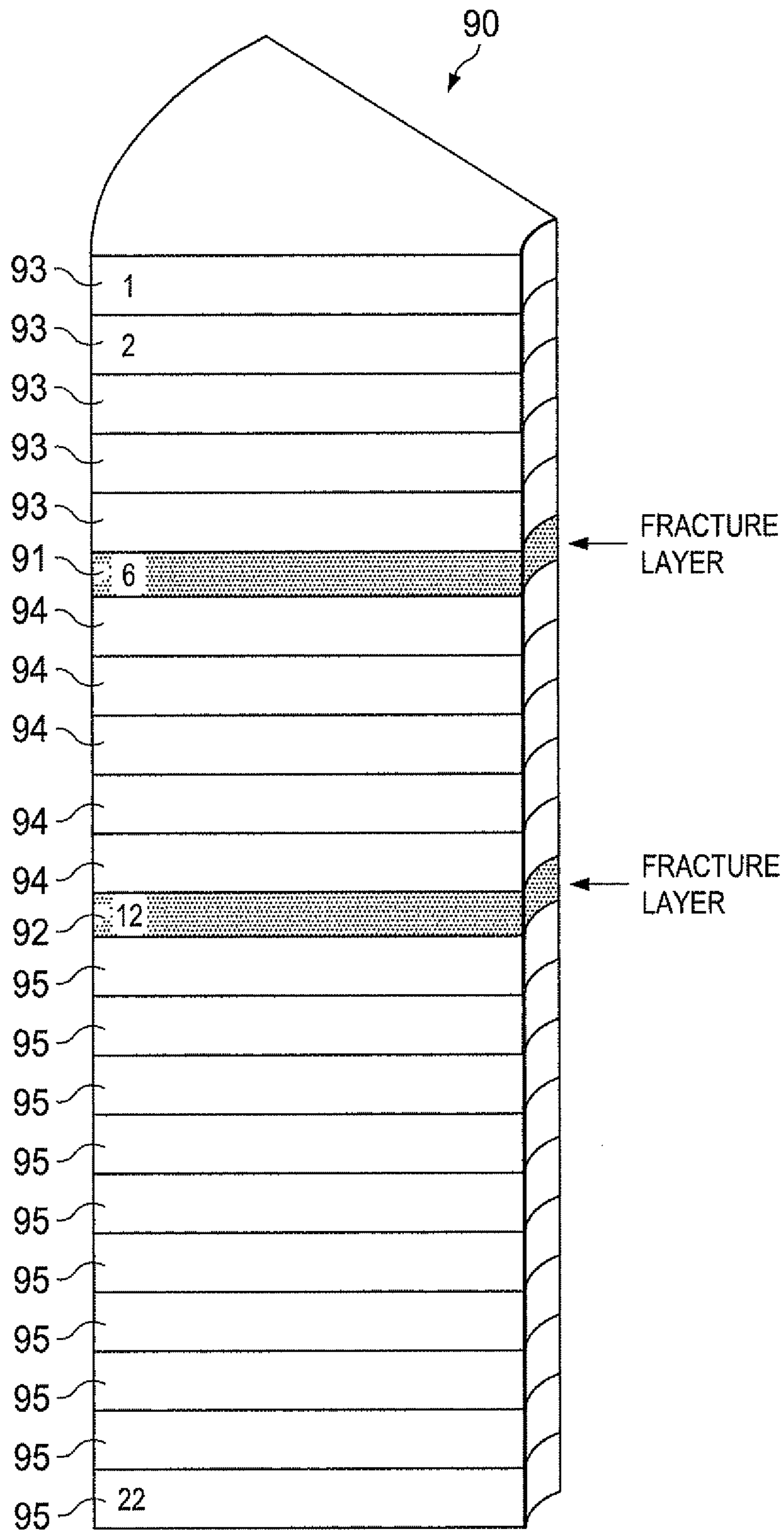
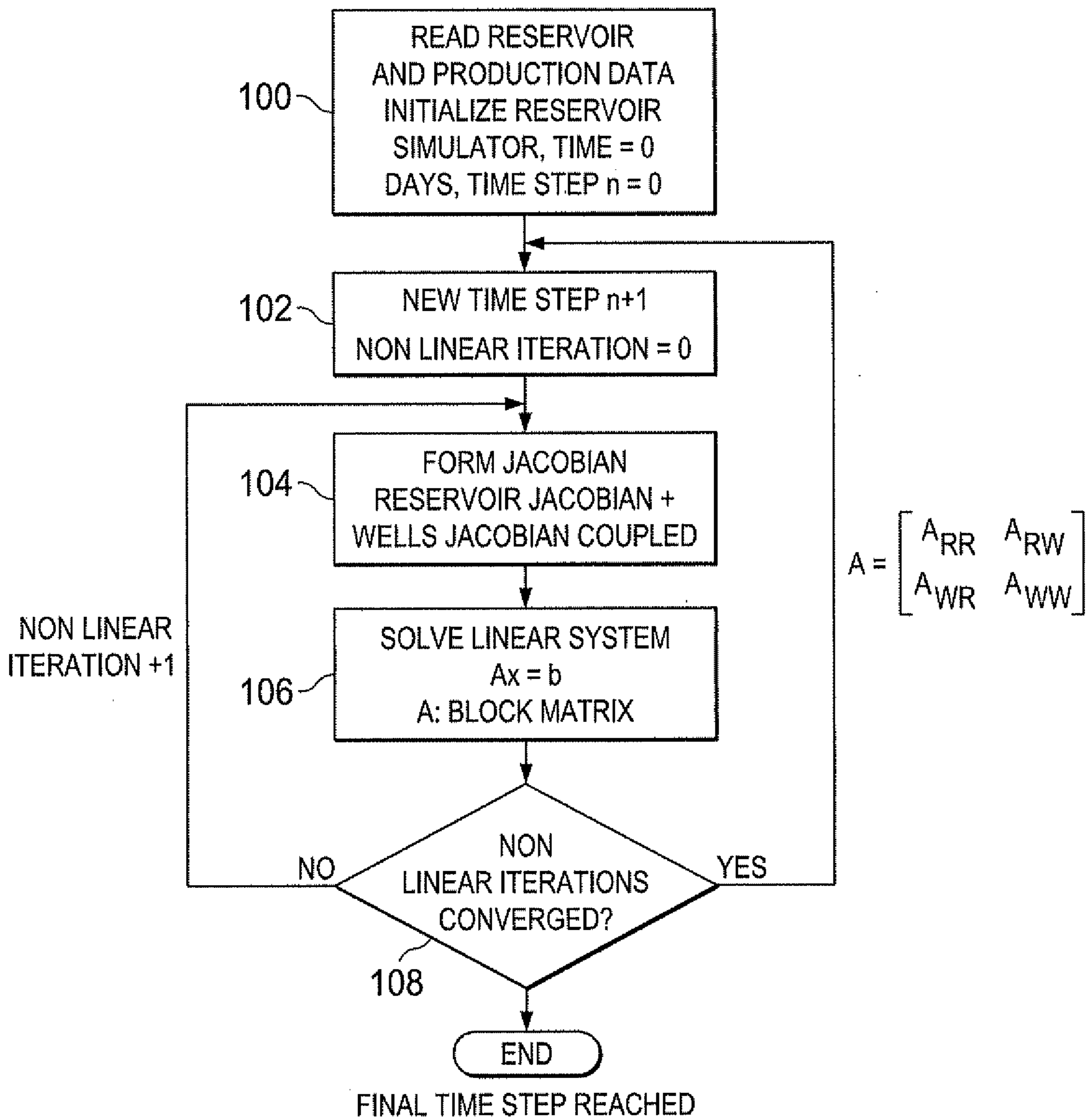

FIG. 9



FIG. 10



F

FIG. 11

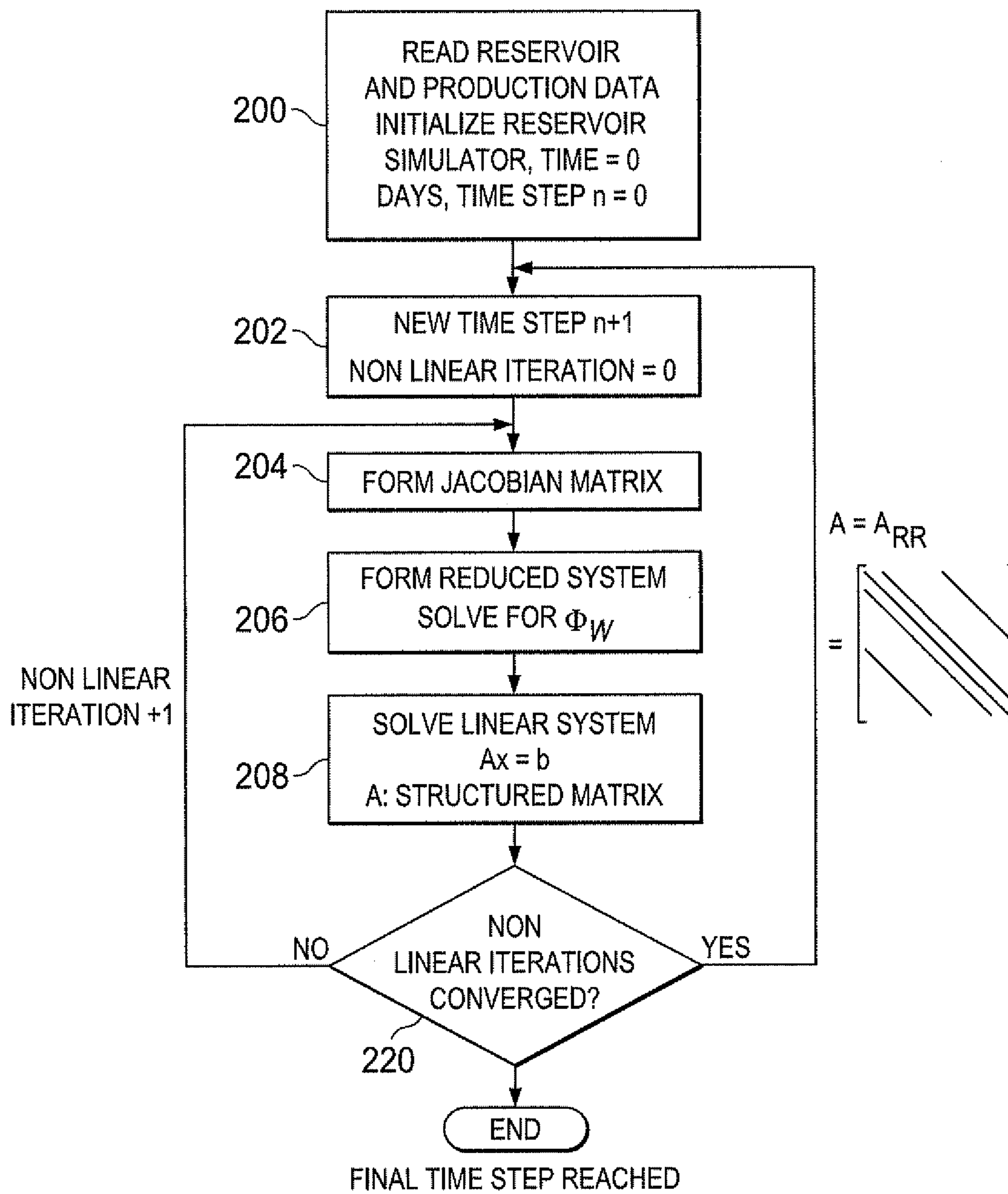

FIG. 12

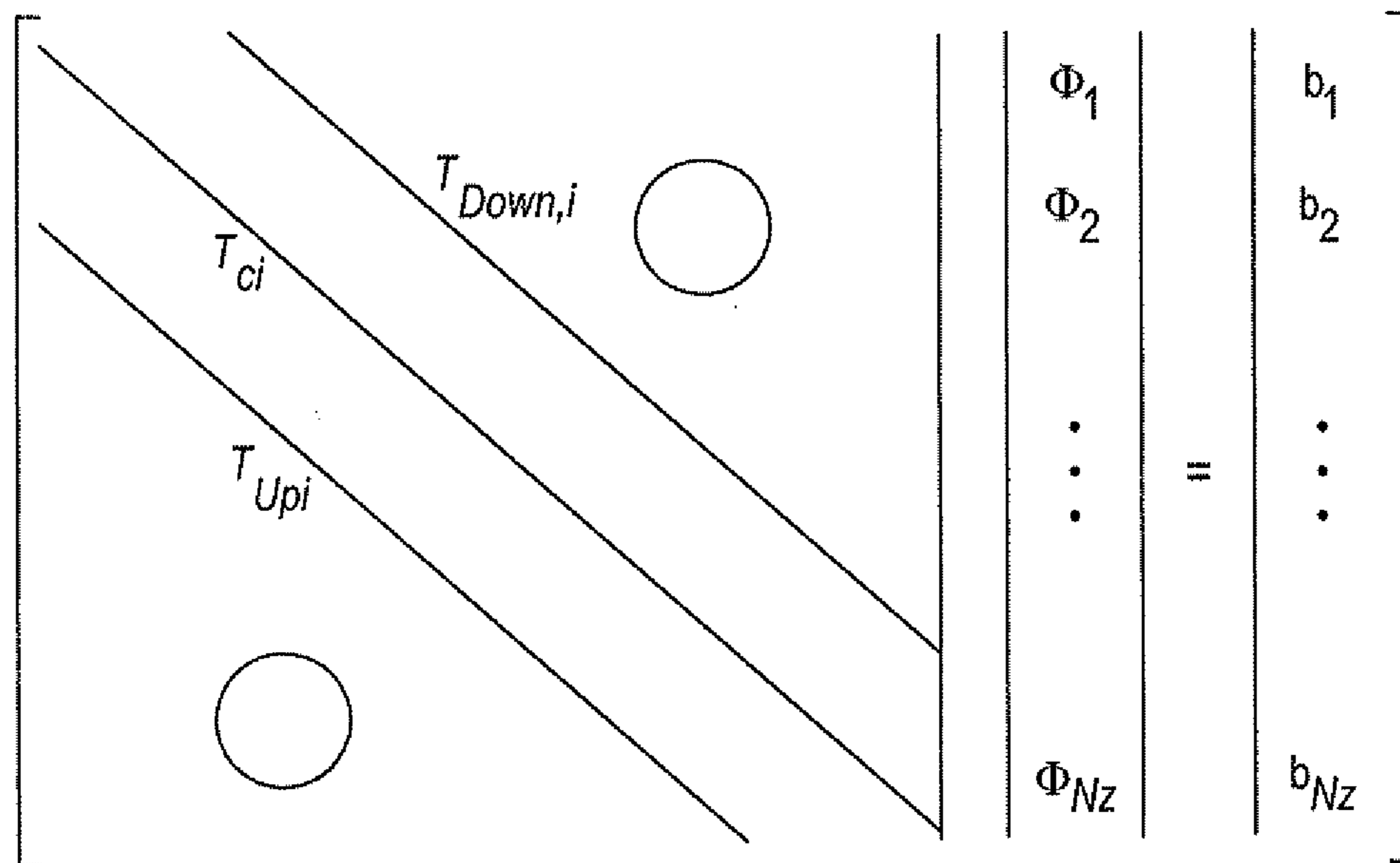

FIG. 13

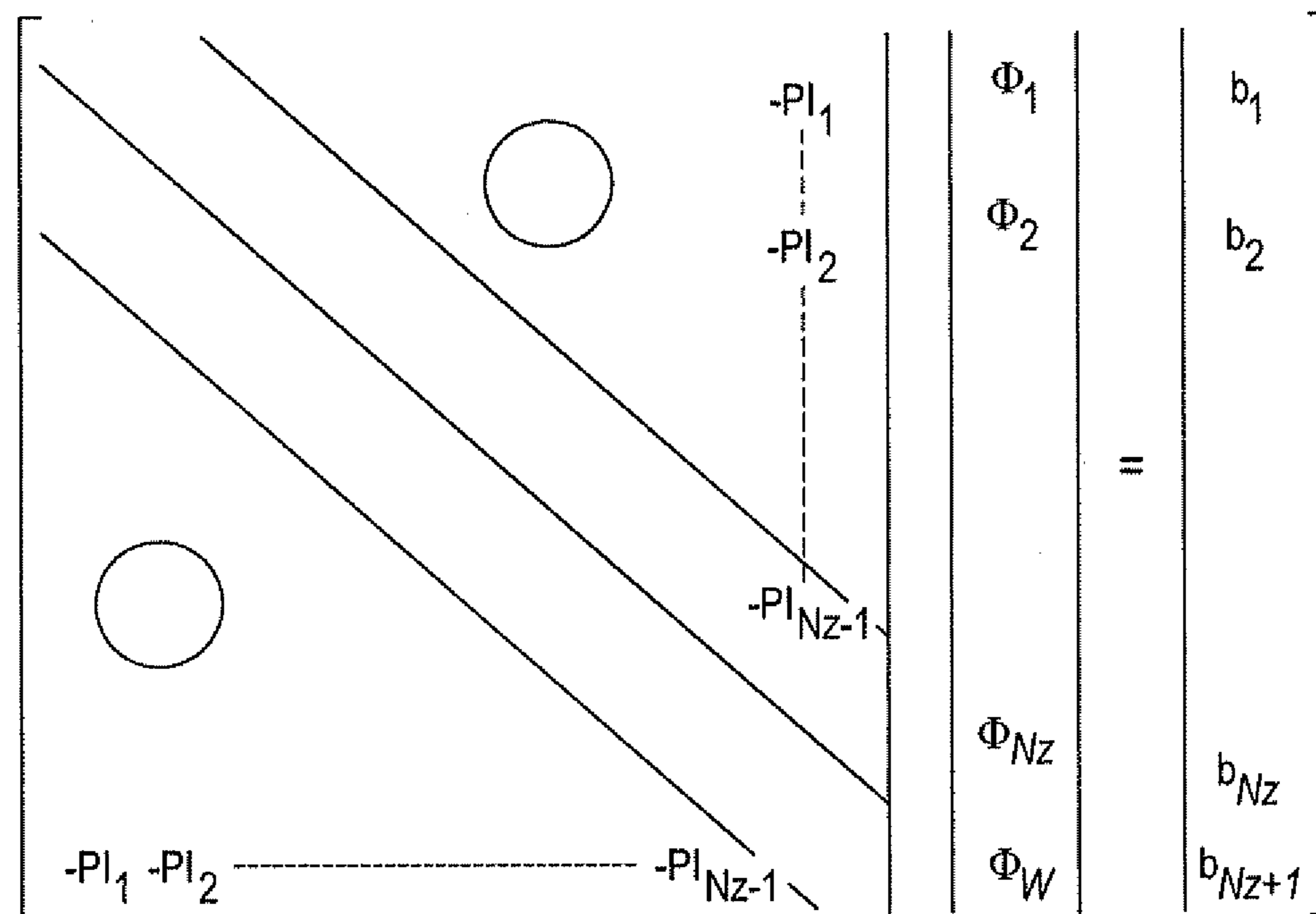

FIG. 14

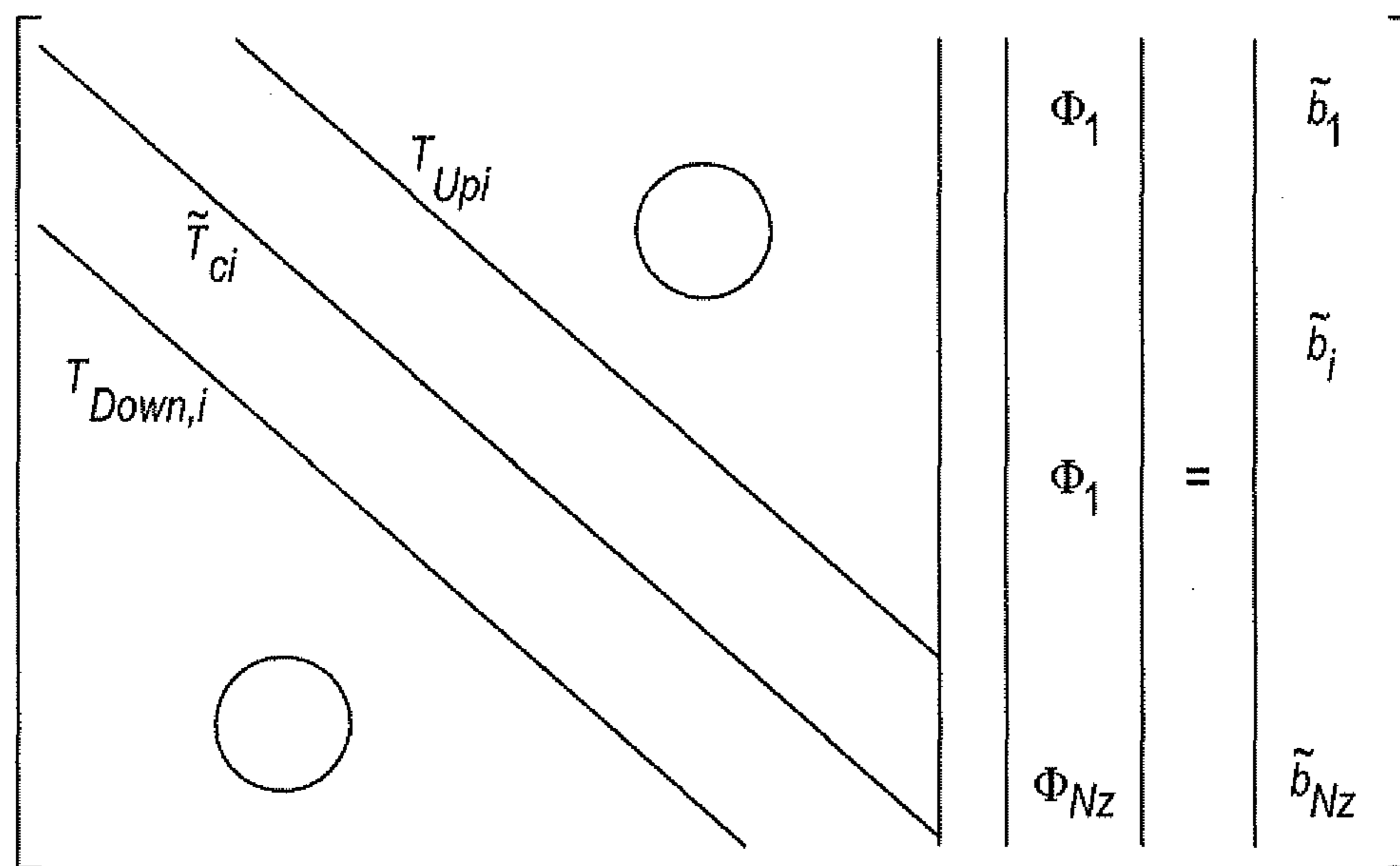

FIG. 16

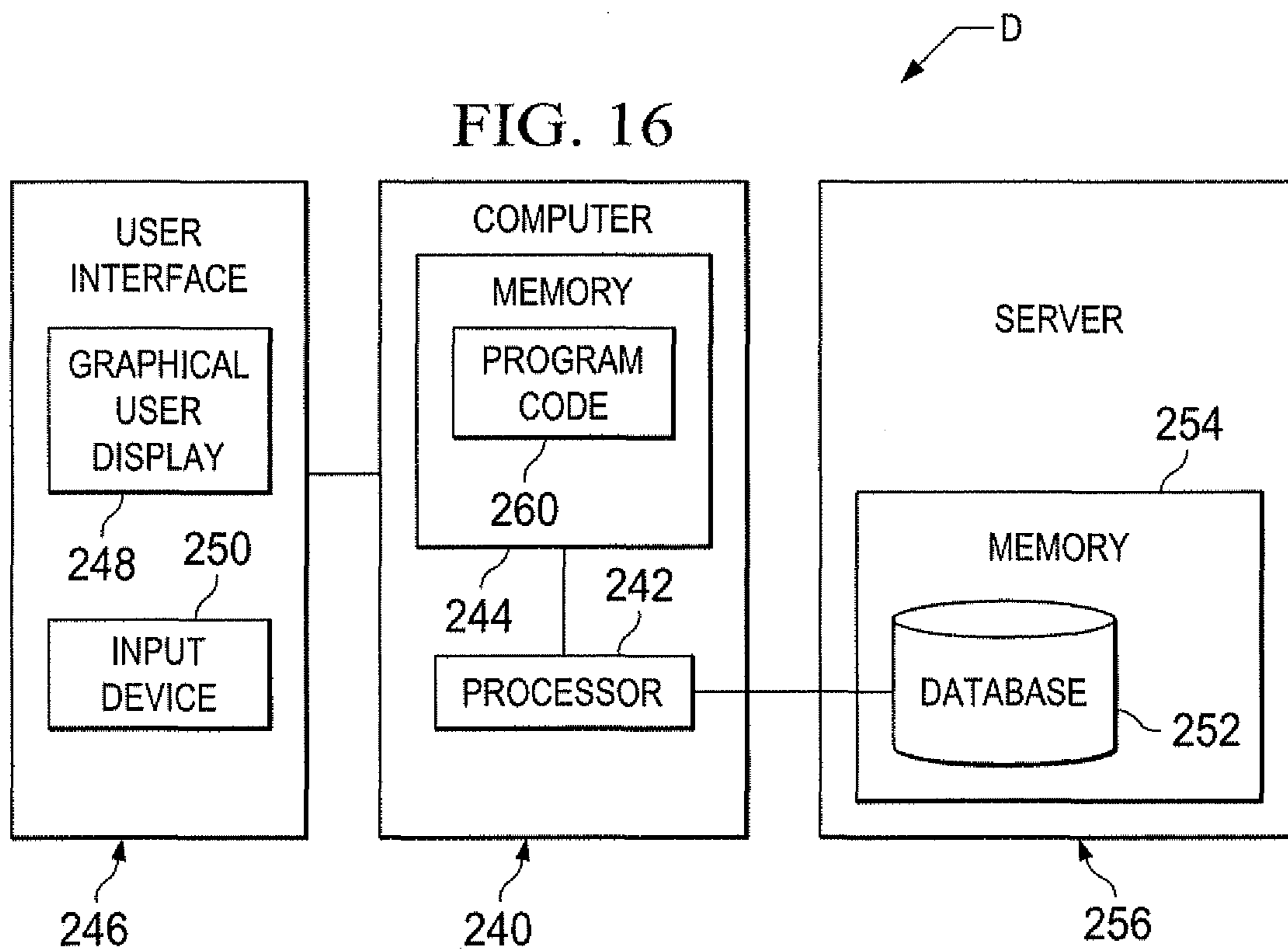
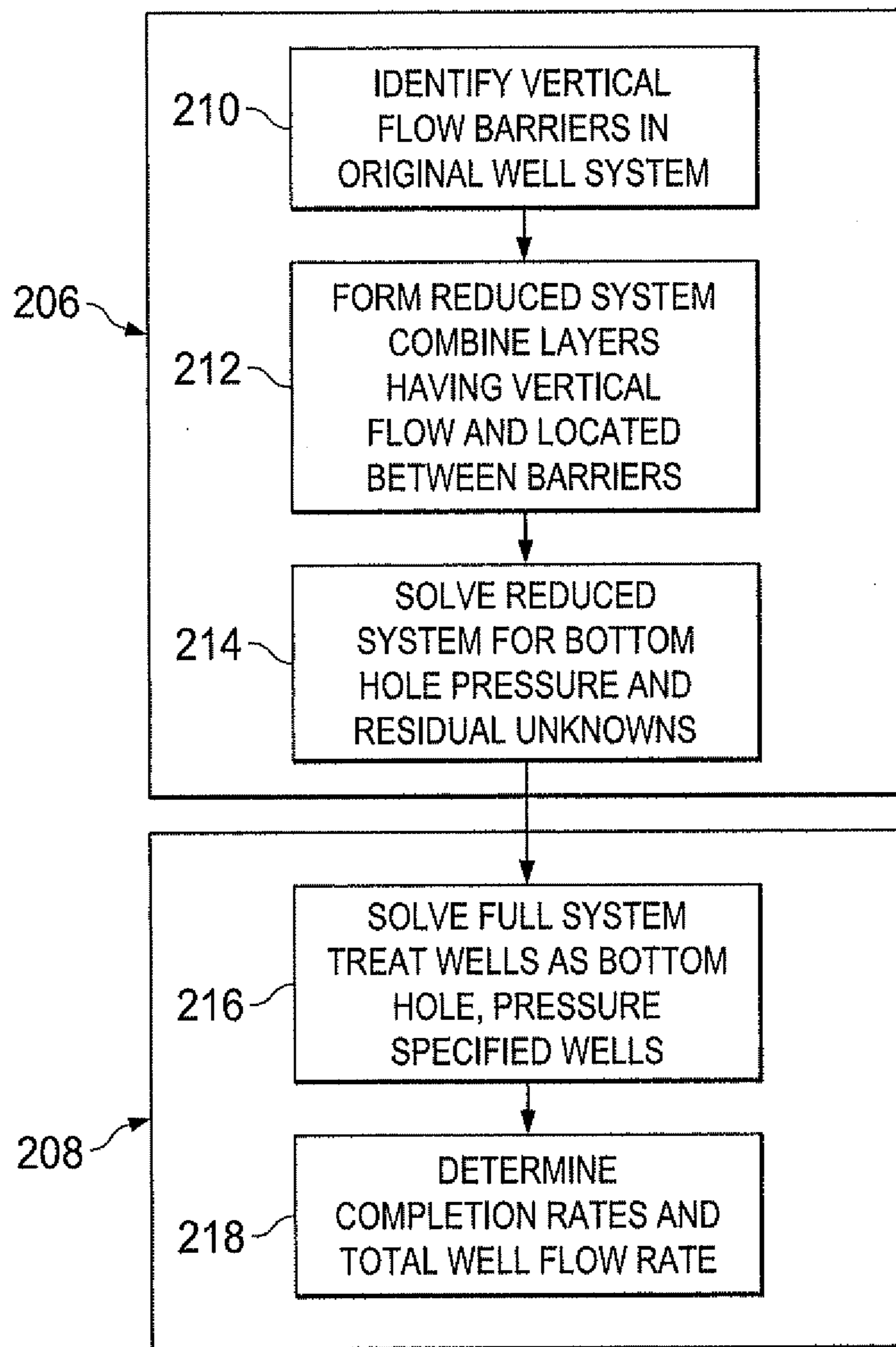

FIG. 15



SEQUENTIAL FULLY IMPLICIT WELL MODEL FOR RESERVOIR SIMULATION

BACKGROUND OF THE INVENTION

1. Field of the Invention

The present invention relates to computerized simulation of hydrocarbon reservoirs in the earth, and in particular to simulation of flow profiles along wells in a reservoir.

2. Description of the Related Art

Well models have played an important role in numerical reservoir simulation. Well models have been used to calculate oil, water and gas production rates from wells in an oil and gas reservoirs. If the well production rate is known, they are used to calculate the flow profile along the perforated interval of the well. With the increasing capabilities for measuring flow rates along the perforated intervals of a well, a proper numerical well model is necessary to compute the correct flow profile to match the measurements.

It is well known that simple well models such as explicit or semi implicit models could be adequate if all reservoir layers communicated vertically. For these models, well production rate was allocated to the perforations in proportion to the layer productivity indices (or total mobility). Therefore, the calculations were simple. The resulting coefficient matrix for the unknowns remained unchanged. Specifically, the coefficient matrix maintained a regular sparse structure. Therefore, any such sparse matrix solver could be used to solve the linear system for the grid block pressures and saturations for every time step.

However, for highly heterogeneous reservoirs with some vertically non-communicating layers, the above-mentioned well models did not produce the correct physical solution. Instead, they produced incorrect flow profiles and in some occasions caused simulator convergence problems.

With the increasing sophistication of reservoir models, the number of vertical layers has come to be in the order of hundreds to represent reservoir heterogeneity. Fully implicit, fully coupled well models with simultaneous solution of reservoir and well equations have been necessary to correctly simulate the flow profiles along the well and also necessary for the numerical stability of the reservoir simulation. In order to solve the fully coupled system, generally well equations were eliminated first. This created an unstructured coefficient matrix for the reservoir unknowns to be solved. Solutions of this type of matrices required specialized solvers with specialized preconditioners. For well with many completions and many wells in a simulation model, this method has become computationally expensive in terms of processor time.

SUMMARY OF THE INVENTION

Briefly, the present provides a new and improved computer implemented method of forming a well model for reservoir simulation of well in a subsurface reservoir from a reservoir model having formation layers having vertical fluid flow and flow barrier layers with no vertical fluid flow. The computer implemented method forms a reduced system model of the reservoir from a full reservoir model by assembling as a single vertical flow layer the flow layers having vertical flow and located adjacent a flow barrier layer in the reservoir model. The method then solves the reduced system model by matrix computation for the bottom hole pressure of the well and residual unknowns. The method then solves the full reservoir model by treating the well as having the determined bottom hole pressure, determines completion rates for the

layers of the well for the full reservoir model, and determines total rate for the well from the determined completion rates for the layers of the well. The method then forms a record of the determined completion rates for the layers and the determined total rate for the well.

The present invention provides a new and improved data processing system for forming a well model for reservoir simulation of well in a subsurface reservoir from a reservoir model having formation layers having vertical fluid flow and flow barrier layers with no vertical fluid flow. The data processing system includes a processor which performs the steps of solving by matrix computation the reduced system model for the bottom hole pressure of the well and residual unknowns and solving the full reservoir model by treating the well as having the determined bottom hole pressure. The processor also determines completion rates for the layers of the well for the full reservoir model and determines total rate for the well from the determined completion rates for the layers of the well. The data processing system also includes a memory forming a record the determined completion rates for the layers and the determined total rate for the well.

The present invention further provides a new and improved data storage device having stored in a computer readable medium computer operable instructions for causing a data processor in forming a well model for reservoir simulation of well in a subsurface reservoir from a reservoir model having formation layers having vertical fluid flow and flow barrier layers with no vertical fluid flow to perform steps of solving by matrix computation the reduced system model for the bottom hole pressure of the well and residual unknowns and solving the full reservoir model by treating the well as having the determined bottom hole pressure. The instructions stored in the data storage device also include instructions causing the data processor to determine completion rates for the layers of the well for the full reservoir model, determine the total rate for the well from the determined completion rates for the layers of the well, and form a record the determined completion rates for the layers and the determined total rate for the well.

BRIEF DESCRIPTION OF THE DRAWINGS

FIGS. 1 and 1A are schematic diagrams of multiple subsurface formation layers above and below a flow barrier in a reservoir being formed into single layers according to the present invention.

FIGS. 2 and 2A are schematic diagrams of multiple subsurface formation layers above and below several vertically spaced flow barriers in a reservoir being formed into single layers according to the present invention.

FIG. 3 is a schematic diagram of a well model for simulation based on an explicit model methodology.

FIG. 4 is a schematic diagram of a well model for simulation based on a fully implicit, fully coupled model methodology.

FIG. 5 is a schematic diagram of a well model for reservoir simulation with a comparison of flow profiles obtained from the models of FIGS. 3 and 4.

FIG. 6 is a schematic diagram of a finite difference grid system for the models of FIGS. 3 and 4.

FIGS. 7A and 7B are schematic diagrams illustrating the reservoir layers for an unmodified conventional well layer model and a well layer model according to the present invention, respectively.

FIGS. 8A and 8B are schematic diagrams of flow profiles illustrating comparisons between the models of FIGS. 7A and 7B, respectively.

FIG. 9 is a schematic diagram of a well layer model having fractured layers.

FIG. 10 is a functional block diagram or flow chart of data processing steps for a method and system for a sequential fully implicit well model for reservoir simulation.

FIG. 11 is a functional block diagram or flow chart of data processing steps for a method and system for a sequential fully implicit well model for reservoir simulation according to the present invention.

FIG. 12 is a schematic diagram of a linear system of equations with a tridiagonal coefficient matrix.

FIG. 13 is a schematic diagram of a linear system of equations for an implicit well model.

FIG. 14 is a schematic diagram of a reservoir coefficient matrix for processing according to the present invention.

FIG. 15 is a functional block diagram or flow chart of steps illustrating the analytical methodology for reservoir simulation according to the present invention.

FIG. 16 is a schematic diagram of a computer network for a sequential fully implicit well model for reservoir simulation according to the present invention.

DETAILED DESCRIPTION OF THE PREFERRED EMBODIMENTS

By way of introduction, the present invention provides a sequential fully implicit well model for reservoir simulation. Reservoir simulation is a mathematical modeling science for reservoir engineering. The fluid flow inside the oil or gas reservoir (porous media) is described by a set of partial differential equations. These equations describe the pressure (energy) distribution, oil, water and gas velocity distribution, fractional volumes (saturations) of oil, water, gas at any point in reservoir at any time during the life of the reservoir which produces oil, gas and water. Fluid flow inside the reservoir is described by tracing the movement of the component of the mixture. Amounts of components such as methane, ethane, CO₂, nitrogen, H₂S and water are expressed either in mass unit or moles.

Since these equations and associated thermodynamic and physical laws describing the fluid flow are complicated, they can only be solved on digital computers to obtain pressure distribution, velocity distribution and fluid saturation or the amount of component mass or mole distribution within the reservoir at any time at any point. This is only can be done by solving these equations numerically, not analytically. Numerical solution requires that the reservoir be subdivided into elements (cells) in the area and vertical direction (x, y, z—three dimensional space) and time is sub-divided into intervals of days or months. For each element, the unknowns (pressure, velocity, volume fractions, etc.) are determined by solving the complicated mathematical equations.

In fact, a reservoir simulator model can be considered the collection of rectangular prisms (like bricks in the walls of a building). The changes in the pressure and velocity fields take place due to oil, water and gas production at the wells distributed within the reservoir. Simulation is carried out over time (t). Generally, the production or injection rate of each well is known. However, since the wells go through several reservoir layers (elements), the contribution of each reservoir element (well perforation) to the production is calculated by different methods. This invention deals with the calculation of how much each well perforation contributes to the total well production. Since these calculations can be expensive and very important boundary conditions for the simulator, the proposed method suggests a practical method to calculate correctly the flow profiles along a well trajectory. As will be

described, it can be shown that some other methods used will result in incorrect flow profiles which cause problems in obtaining the correct numerical solution and can be very expensive computationally.

The equations describing a general reservoir simulation model and indicate the well terms which are of interest in connection with the present invention are set forth below.

$$\Delta x \sum_{j=1}^{n_p} \rho_{i,j} \lambda_j \Delta x \Phi_j + \Delta y \sum_{j=1}^{n_p} \rho_{i,j} \lambda_j \Delta y \Phi_j + \Delta z \sum_{j=1}^{n_p} \rho_{i,j} \lambda_j \Delta z \Phi_j + q_{i,w,k} \Delta t n_i \quad (1)$$

$$i = 1, n_c$$

Nomenclature

$\Delta x, \Delta y, \Delta z$ —Grid Dimensions in x, y and z directions

k_x, k_y, k_z —permeability in x, y and z directions

P=Pressure

ρ =fluid (oil) density

g=gravitational constant

z=vertical depth from a datum depth

r_o =Peaceman's radius=0.2 Δx

r_w =wellbore radius

Equation (1) is a set of coupled non linear partial differential equations describing the fluid flow in the reservoir. In the above set of equations n_i represents the i th component of the fluids. n_c is the total number of components of the hydrocarbons and water flowing in the reservoir. Here a component means such as methane, ethane, propane, CO₂, H₂S, water, etc. The number of components depends on the hydrocarbon water system available for the reservoir of interest. Typically, the number of components can change from 3 to 10. Equation (1) combines the continuity equations and momentum equations.

In Equation (1) is the well perforation rate at location x_k, y_k, z_k for component i . Again, the calculation of this term from the specified production rates at the well head is the subject of the present invention.

In addition to the differential equations in Equation (1), pore volume constraint at any point (element) in the reservoir must be satisfied:

$$V_p(P(x, y, z)) = \sum_{j=1}^{n_p} \frac{N_j}{\rho_j} \quad (2)$$

There are n_c+1 equations in Equations (1) and (2), and n_c+1 unknowns. These equations are solved simultaneously with thermodynamics phase constraints for each component by Equation (3)

$$f_i^V(n_{iV}; n_1, n_2, \dots, n_{n_c}, P, T) = f_i^L(n_{iL}; n_1, n_2, \dots, n_{n_c}, P, T) \quad (3)$$

In the fluid system in a reservoir typically there are three fluid phases: oil phase, gas phase and water phase. Each fluid phase may contain different amounts of components described above based on the reservoir pressure and temperature. The fluid phases are described by the symbol j . The symbol j has the maximum value 3 (oil, water and gas phases). The symbol n_p is the maximum number of phases (sometimes it could be 1 (oil); 2 (oil and gas or oil and water); or 3 (oil, water and gas)). The number of phases n_p varies based on reservoir pressure (P) and temperature (T). The symbol n_i is the number of moles of component i in the fluid system. The

5

symbol n_c is the maximum number of components in the fluid system. The number of phases and fraction of each component in each phase $n_{i,j}$ as well as the phase density ρ_j and $\rho_{i,j}$ are determined from Equation (3). In Equation (3), V stands for the vapor (gas) phase and L stands for liquid phase (oil or water).

The phase total is defined by:

$$N_j = \sum_{i=1}^{n_c} n_{i,j} \quad (4)$$

Total component moles are defined by Equation (5).

$$n_i = \sum_{j=1}^{n_p} n_{i,j} \quad (5)$$

Phase mobility in Equation (1), the relation between the phases, definition of fluid potential and differentiation symbols are defined in Equations (6) through (9).

$$\lambda_j = \frac{k_{r,j}}{\mu_j} \quad (6)$$

In Equation (6), the numerator defines the phase relative permeability and the denominator is the phase viscosity.

The capillary pressure between the phases are defined by Equation (7) with respect to the phase pressures:

$$P_c(s_j, s_j) = P_j - P_j \quad (7)$$

The fluid potential for phase j is defined by:

$$\Phi_j = P_j - g\rho_j z \quad (8)$$

Discrete differentiation operators in the x, y, and z directions are defined by:

$$\Delta_x = \frac{\delta}{\delta x}, \Delta_y = \frac{\delta}{\delta y}, \Delta_z = \frac{\delta}{\delta z}, \Delta_t = \frac{\delta}{\delta t} \quad (9)$$

δ defines the discrete differentiation symbol.

Equations (1) and (2), together with the constraints and definitions in Equations (3) through (9), are solved simultaneously for a given time t in simulation by a well model which is the subject of the present invention. This is done to find the distribution of n_i (x, y, x, and t), P (x, y, z, and t) for the given well production rates q_T for each well from which the component rates in Equation (1) are calculated according to the present invention. In order to solve Equations (1) and (2), reservoir boundaries in (x, y, z) space, rock property distribution K (x, y, z), rock porosity distribution and fluid properties and saturation dependent data is entered into simulation.

According to the present invention and as will be described below, a reduced system for reservoir simulation is formed which yields the same determination of a calculated bottom hole pressure as complex, computationally time consuming prior fully coupled well models. According to the present invention, it has been determined that where a number of formation layers communicate vertically, the communicating layers can be combined for processing into a single layer, as

6

indicated schematically in FIGS. 1 and 2. This is done by identifying the vertical flow barriers in the reservoir, and combining the layers above and below the various flow barriers. Therefore, the full system is reduced to a smaller dimensional system with many fewer layers for incorporation into a model for processing.

As shown in FIG. 1, a model L represents in simplified schematic form a complex subsurface reservoir which is composed of seven individual formation layers 10, each of which is in flow communication vertically with adjacent layers 10. The model L includes another group of ten formation layers 12, each of which is in flow communication vertically with adjacent layers 12. The groups of formation layers 10 and 12 in flow communication with other similar adjacent layers in model L are separated as indicated in FIG. 1 by a fluid impermeable barrier layer 14 which is a barrier to vertical fluid flow.

According to the present invention, the model L is reduced for processing purposes to a reduced or simplified model R (FIG. 1A) by lumping together or combining, for the purposes of determining potential Φ and completion rates, the layers 10 of the model L above the flow barrier 14 into a composite layer 10a in the reduced model R. Similarly, the layers 12 of the model L below the flow barrier 14 are combined into a composite layer 12a in the reduced model R.

Similarly, as indicated by FIG. 2, a reservoir model L-1 is composed of five upper individual formation layers 20, each of which is in flow communication vertically with adjacent layers 20. The model L-1 includes another group of seven formation layers 22, each of which is in flow communication vertically with adjacent layers 22. The groups of formation layers 20 and 22 in flow communication with other similar adjacent layers in model L-1 are separated as indicated in FIG. 2 by a fluid impermeable barrier layer 24 which is a barrier to vertical fluid flow. Another group of nine formation layers 25 in flow communication with each other are separated from the layers 22 below a fluid barrier layer 26 which is a vertical fluid flow barrier as indicated in the model L-1. A final lower group of ten formation layers 27 in flow communication with each other are located below a fluid flow barrier layer 28 in the model L-1.

According to the present invention, the model L-1 is reduced for processing purposes to a reduced or simplified model R-1 (FIG. 2A) by lumping together or combining, for the purposes of determining potential Φ and completion rates, the layers 20 of the model L-1 above the flow barrier 24 into a composite layer 20a in the reduced model R. Similarly, other layers 22, 25, and 27 of the model L-1 below flow barriers 24, 26 and 28 are combined into composite layers 22a, 25a, and 27a in the reduced model R-1.

The reduced systems or models according to the present invention are solved for the reservoir unknowns and the bottom hole pressure. Next, the wells in the full system are treated as specified bottom hole pressure and solved implicitly for the reservoir unknowns. The diagonal elements of the coefficient matrix and the right hand side vector for the reservoir model are the only components which are modified in processing according to the present invention, and these are only slightly modified. A regular sparse solver technique or methodology is then used to solve for the reservoir unknowns. The perforation rates are computed by using the reservoir unknowns (pressures and saturations). These rates are then summed up to calculate the total well rate. The error between the determined total well rate according to the present invention and the input well rate will diminish with the simulator's Newton iterations for every time step.

The flow rates calculated according to the present invention also converge with the flow rates calculated by the fully

coupled simultaneous solution. Because the present invention requires solving a small system model, the computational cost is less. It has been found that the methodology of the present invention converges if the reduced system is constructed properly, by using upscaling properly when combining communicating layers.

It is well known that simple well models such as explicit or semi-implicit models have been generally adequate if all reservoir layers communicate vertically. As shown in FIG. 3, an explicit model E is composed of a number Nz of reservoir layers 30 in vertical flow communication, each layer having a permeability k and a thickness Δz and a perforation layer rate q_i defined as indicated in FIG. 3. The total production rate q_T for the explicit model E is then the sum of the individual production rates q_i for the Nz layers of the explicit model as indicated in Equation (3) below.

For explicit models, the well production rate is allocated to the perforations in proportion to the layer productivity indices (or total mobility). Therefore, the calculations are simple. The resulting coefficient matrix for the unknowns remains unchanged, i.e., maintains a regular sparse structure, as shown in matrix format in FIG. 12. Therefore, any sparse matrix solver can be used to solve the linear system for the grid block pressures and saturations for every time step. The linear system is presented in Equation (15) below.

Well Models

The methodology of several models is presented based also for simplicity on a simple fluid system in the form of flow of an incompressible single phase oil flow inside the reservoir. However, it should be understood that the present invention general in applicability to reservoirs, and can be used for any number of wells and fluid phases in a regular reservoir simulation model.

FIG. (6) illustrates the finite difference grid G used in this description. As seen, a well is located at the center of the central cell in vertical directions. The models set forth below also contemplate that the well is completed in the vertical Nz directions, and the potentials in the adjacent cells:

Φ_{BW} , Φ_{BE} , Φ_{BN} , Φ_{BS}
are constants.

The steady state volume balance equation for the cell (i) in FIG. 6 is as follows:

$$T_{wi}(\Phi_{BW}-\Phi_i)+T_{Ei}(\Phi_{BE}-\Phi_i)+T_{Ni}(\Phi_{BN}-\Phi_i)+T_{Up,i}(\Phi_{i-1}-\Phi_i)+T_{Down,i}(\Phi_{i+1}-\Phi_i)-q_i=0.0 \quad (10)$$

In Equation (11), T represents the transmissibility between the cells. The subscripts W, E, N, and S denote west, east, south and north directions, and (i) represent the cell index.

The transmissibilities between cells for three directions are defined by Equation (11) below:

$$\begin{aligned} T_{wi} &= k_{x,i-1/2} \frac{\Delta y_i \Delta z_i}{0.5(\Delta x_{i-1} + \Delta x_i)} \\ T_{Ni} &= k_{y,i-1/2} \frac{\Delta x_i \Delta z_i}{0.5(\Delta y_{i-1} + \Delta y_i)} \\ T_{Up,i} &= k_{z,i-1/2} \frac{\Delta x_i \Delta y_i}{0.5(\Delta z_{i-1} + \Delta z_i)} \\ T_{Down,i} &= k_{z,i+1/2} \frac{\Delta x_i \Delta y_i}{0.5(\Delta z_{i+1} + \Delta z_i)} \end{aligned} \quad (11)$$

Other transmissibilities in Equation (10) are defined in a similar manner to the three transmissibility expressions given in Equation (10).

Conventional well models can be generally classified in three groups: (a) the Explicit Well Model; (b) the Bottom Hole Pressure Specified Well Model; and the Fully Implicit Well Model. For a better understanding of the present invention, a brief review of each well model is presented.

Explicit Well Model

For an explicit well model, the source term q_i in Equation (10) is defined according to Equation (12) by:

$$q_i = \frac{k_{x,i} \Delta z_i}{\sum_{i=1}^{Nz} k_{x,i} \Delta z_i} q_T \quad (12)$$

Substituting Equation (12) into Equation (10) for cell i results in

$$T_{Up,i} \Phi_{i-1} - T_{C,i} \Phi_i + T_{Down,i} \Phi_{i+1} = b_i \quad (13)$$

where

$$T_{C,i} = T_{Up,i} + T_{Down,i} + T_{Wi} + T_{Ei} + T_{Ni} + T_{Si}; \quad (14a)$$

and

$$b_i = -\frac{k_{x,i} \Delta z_i}{\sum_{i=1}^{Nz} k_{x,i} \Delta z_i} q_T - (T_{Wi} \Phi_{BW} + T_{Ei} \Phi_{BE} + T_{Ni} \Phi_{BN} + T_{Si} \Phi_{BS}) \quad (14b)$$

Writing Equation (5) for all the cells $i=1, Nz$ results in a linear system of equations with a tridiagonal coefficient matrix of the type illustrated in FIG. 12, which can be written in matrix vector notation as below:

$$A_{RR} \vec{\Phi}_R = \vec{b}_R \quad (15)$$

In Equation (6), A_{RR} is a (Nz×Nz) tridiagonal matrix, and Φ_R and b_R are (Nz×1) vectors. Equation (6) is solved by computer processing for the reservoir unknown potentials Φ_R by a tridiagonal linear system solver such as the Thomas algorithm.

Bottomhole Pressure Specified Well Model

Φ_w is the uniform potential along the wellbore open to production using conventional techniques according to techniques explained in the literature, such as the textbooks by Muskat "Physical Principles of Oil Production", McGraw-Hill Book Co. (1949) and "The Flow of Homogeneous Fluids Through Porous Media", McGraw-Hill Book Co. (1937). For the purposes of modeling in the present context, the friction pressure drop along the well is considered negligible. Assuming that Φ_w is known (or specified), the oil rate from the perforation is calculated by Equation (16) as follows:

$$\begin{aligned} q_i &= P I_i (\Phi_i - \Phi_w) \\ &= \frac{2\pi k_{x,i} \Delta z_i}{\ln(r_{o,i}/r_w)} (\Phi_i - \Phi_w) \end{aligned} \quad (16)$$

The variables in Equation (16) are explained in the Nomenclature section above. Substituting Equation (16) into Equation (10) and collecting the terms for the cell i , for cell i the following result occurs:

$$T_{Up,i}\Phi_{i-1}+T_{C,i}\Phi_i+T_{Down,i}\Phi_{i+1}W=b_i \quad (17)$$

$$\text{Let } T_{ci}=-\left(T_{Up,i}+T_{down,i}+T_{wi}+T_{Ei}+T_{Ni}+T_{Si}+PI_i\right) \quad (17a)$$

$$b_i=-\left(PI_i\Phi_W+T_{wi}+T_{Ei}\Phi_{BE}+T_{Ni}\Phi_{BN}+T_{Si}\Phi_{BS}\right) \quad (17b)$$

Equation (17) when written for all the grid blocks $i=1, Nz$ results in a matrix system illustrated in FIG. 13. The matrix of FIG. 13 for the bottom hole pressure specified well model can be seen to be similar to the matrix of FIG. 12, and in a comparable manner Equation (17) is similar to Equation (15). The bottom hole pressure specified well model can be easily solved matrix by matrix computer processing with a tridiagonal equation solver methodology.

Fully Implicit Well Model

Total production rate q_T for a well according to a fully implicit well model is specified according to Equation (18).

$$q_T - \sum_{i=1}^{i=Nz} PI_i(\Phi_i - \Phi_W) = 0.0 \quad (18)$$

The individual completion rate q_i is calculated by Equation (15). For the implicit well model, the wellbore potential Φ_W is assumed constant throughout the well but it is unknown.

Substituting Equation (18) into Equation (10) and collecting the terms for the cell i for cell (i) arrives at the following expression:

$$T_{Up,i}\Phi_{i-1}+T_{C,i}\Phi_i+T_{Down,i}\Phi_{i+1}W-PI_i\Phi_W=b_i \quad (19)$$

Let

$$T_{ci}=-\left(T_{Up,i}+T_{down,i}+T_{wi}+T_{Ei}+T_{Ni}+PI_i\right) \quad (19a)$$

$$b_i=-\left(T_{wi}\Phi_{BW}+T_{Ei}\Phi_{BE}+T_{Ni}\Phi_{BN}+T_{Si}\Phi_{BS}\right) \quad (19b)$$

Writing Equation (19) for all cells yields a linear system of equations with the form illustrated in FIG. 14, lower diagonal solid line represents $T_{Up,i}$ as defined by Equation (2), and the upper diagonal solid line describes the elements called $T_{Down,i}$ described above. The central term $T_{C,i}$ is defined by Equation (10a) and right hand side b_i is defined by Equation (10b).

The linear system of the matrix of FIG. 14 can be represented in vector matrix notation as below:

$$\begin{bmatrix} A_{RR} & A_{RW} \\ A_{WR} & A_{WW} \end{bmatrix} \begin{bmatrix} \vec{\Phi}_R \\ \Phi_W \end{bmatrix} = \begin{bmatrix} \vec{b}_R \\ b_W \end{bmatrix} \quad (20)$$

In Equation (20), A_{RR} is a $(Nz \times Nz)$ tridiagonal matrix, A_{RW} is a $(Nz \times 1)$ vector (reservoir PI's), A_{WR} is a $(1 \times Nz)$ vector (PI's) and A_{WW} is (1×1) scalar. For this example:

$$\left(A_{WW} = \sum_{i=1}^{Nz} PI_{NZ} \right)$$

Writing in algebraic form:

$$A_{RR}\vec{\Phi}_R+A_{RW}\Phi_W=\vec{b}_R \quad (21)$$

$$A_{wR}\vec{\Phi}_R+A_{ww}\Phi_W=b_w \quad (22)$$

Solving for Φ_W results in:

$$\Phi_W=A_{ww}^{-1}(b_w-A_{wR}\vec{\Phi}_R) \quad (23)$$

Substituting into Equations (12) and (13)

$$A_{RR}\vec{\Phi}_R+A_{RW}A_{ww}^{-1}(b_w-A_{wR}\vec{\Phi}_R)=\vec{b}_R \quad (24)$$

Collecting the terms in Equation (25) produces:

$$(A_{RR}-A_{RW}A_{ww}^{-1}A_{wR})\vec{\Phi}_R=\vec{b}_R-A_{RW}A_{ww}^{-1}b_w \quad (25)$$

The coefficient matrix $(A_{RR}-A_{RW}A_{ww}^{-1}A_{wR})$ of Equation (24) is an $(Nz \times Nz)$ full matrix.

The resulting coefficient matrix can be defined as follows:

$$\tilde{A}=A_{RR}-A_{RW}A_{ww}^{-1}A_{wR} \quad (26)$$

and

$$\tilde{b}=\vec{b}_R-A_{RW}A_{ww}^{-1}b_w$$

Then Equation (26) can be written as:

$$\tilde{A}\vec{\Phi}_R=\tilde{b}_R \quad (27)$$

The matrix of Equation (18) can be solved by a direct solver by Gaussian elimination or any other suitable conventional solver for the full matrices.

If in the implicit well model the number of layers Nz is large, and wells are fully completed in all the layers, then the solution of Equation (27) becomes expensive in computation time. For this reason and also if many wells are involved, generally Equation (27) is solved by iterative methods by reducing the coefficient matrix to a sparse matrix by preconditioning. An example of this is described in "A Fully-Implicit Fully-Coupled Well Model for Parallel Mega-Cell Reservoir Simulation", SPE Technical Symposium of Saudi Arabia Section, 14-16 May 2005.

A flow chart I (FIG. 10) indicates the basic computer processing sequence of fully implicit, fully coupled well model simultaneous solution for the type of matrix illustrated in FIG. 12. During a step 100, simulation begins by reading the reservoir and production data. Reservoir data includes reservoir geometric information-its size, extent (length) in x, y, and z directions, reservoir properties such as permeability distribution, porosity distribution, thickness of layers, relative permeability data, capillary pressure data, fluid property data such as fluid density tables, formation volume factor tables, viscosity tables, location of wells, location of well perforations within the reservoir

Production data includes oil, water, and gas production rate measured or specified for the wells defined in the previous step. Production data also includes minimum bottomhole pressure for each well.

In many instances, only oil production rates and water production rates are input if the gas production data is not available. If no water is produced in the field, only oil production rates are read as input.

During step 102 the time step is incremented by one, and an iteration counter of the number of non-linear iterations performed during the present time step is set to zero. During step 104, a Jacobian matrix of reservoir data is formed. In step 106, the resultant linear system of Equation (18) is then solved by iterative methods by reducing the coefficient matrix to a sparse matrix by preconditioning. During step 108, a conver-

gence step is performed to determine whether the non-linear iterations have converged. The individual residuals of the equations resulting from step **106** are checked against user-specified tolerances. If these tolerances are satisfied, the non-linear iteration loop is exited, the solution output is written to file for the current time step and processing returns to step **102** for the time step to be advanced, and processing for the incremented time step proceeds as indicated. If the user-specified tolerances are determined not satisfied during step **108**, processing according to the non-linear iteration loop returns to step **114** and continues. If the number on nonlinear iterations becomes too large, a decision may be made to adjust the model.

However, based on the strength of the preconditioning, this method can also be very expensive in computation time, since there is no exact way of representing the full matrix in Equation (18) by a sparse matrix. For difficult problems, with extreme heterogeneity and small layer thicknesses, the iterative method may not converge.

Additionally, for highly heterogeneous reservoirs with some vertically non-communicating layers, the above described well models do not produce the correct physical solution. Instead, they can produce incorrect flow profiles, and in some occasions they can cause simulator convergence problems.

The Present Invention

Explicit and fully implicit models can produce totally different flow profiles in case of some vertical flow barriers. This is displayed in FIG. 5. As shown in FIG. 5, a reservoir model V is composed of an upper layer **50** of relatively low permeability, and with vertical flow, located above an isolated high permeability layer **52** with no vertical flow communication with adjacent layers. The flow barrier layer **52** is located in the reservoir V above a layer **54** of medium permeability and having vertical flow communication. As can be seen in FIG. 5, the production rates q_T for the model V are the same for both implicit and explicit well modeling methods. However, the production rates q_1 , q_2 , and q_3 of layers **50**, **52** and **54** differ significantly. The production rate q_2 for the layer **52** is the major contribution to the total production rate q_T as shown by curve **56** for the explicit model. On the contrary, for the implicit model as shown by curve **58**, production rate q_2 for the layer **52** is markedly less. In the fully implicit well model, the production rate for the layer **2** is significantly less due to the fact that this method takes into account internal reservoir heterogeneity (all the reservoir properties throughout the reservoir) in addition to the perforation index (or layer **2** property alone as is used by the explicit method as the only data to assign the rate fraction to this perforation). For example, the fully implicit method sees that there is no fluid supplied into layer **2** from layer **1** and layer **3** due to the impermeable barrier between layer **2** and layer **1** and **3**. Therefore, once some fluid is produced from layer **2**, the pressure of layer **2** should go down and this layer should not supply at a high rate into the well, although the layer has very high permeability. On the other hand, the explicit method assigns the rate for layer **2** based on the permeability of this layer alone without considering the layer connection to the above and below layers. Based on this, the explicit method will assign a very high rate for this layer. In later simulation time steps, this will cause instability in the production rates, i.e., the simulator will reduce the time step size and will take a very long time to complete the simulation. It is unsatisfactory for reservoir

simulation to have models provide divergent results for the same input data based on the modeling technique selected for use.

According to the present invention, a more comprehensive well model is provided. The well model according to the present invention is called a coupled reservoir well model. The associated numerical solution is referred to fully implicit, fully coupled and simultaneous solution. A fully implicit fully coupled reservoir well model produces correct flow profile along the perforated well interval, as will be described. As shown in FIG. 4, a reservoir model O is composed of a number Z of i individual layers **1** through N_z , each with a permeability $k_{x,i}$ and a thickness Δz_i and a potential Φ_i defined as indicated in FIG. 4, and upper and lower layers **40** of relatively low permeability, and with vertical flow, located above and below, respectively, an isolated high permeability layer **42** with no vertical flow communication with adjacent layers. As can be seen in FIG. 4, the production rates q_i for layer i of the model O is indicated by the expression set forth in FIG. 5.

The fully implicit coupled reservoir well model V of FIG. 5 is presented in Equation 6 above and is also presented here in matrix format for further description:

$$\begin{bmatrix} A_{RR} & A_{RW} \\ A_{WR} & A_{WW} \end{bmatrix} \begin{bmatrix} \bar{X}_R \\ \bar{X}_W \end{bmatrix} = \begin{bmatrix} \bar{b}_R \\ \bar{b}_W \end{bmatrix}$$

The present invention is based on the fact that the bottom hole pressure of a layered reservoir with a vertical well is the same as a system according to the present invention. The system according to the present invention is formed by identifying flow barriers and lumping together or combining for processing purposes the reservoir layers which are communicating in the vertical direction. Care should be taken according to the present invention in the formation of the reduced system. The reduced system must be formed correctly, or otherwise errors in the reduced system construction can increase the total number of Newton iterations.

The system according to the present invention is solved for the bottom hole pressure. The solution is carried out by treating the well as specified bottom hole pressure well. The procedure is fully implicit; however, it is not a simultaneous solution. Instead, the solution is sequential. The method of the present invention is convergent since it is part of the global Newton iteration of the simulator. Therefore, if the model according to the present invention is constructed correctly, any possible error in rate calculations will be small and will diminish with the simulator Newtonian iterations.

A flow chart F (FIG. 11) illustrates the basic computer processing sequence according to the present invention and the computational methodology taking place during a typical embodiment of a sequential fully implicit well model for reservoir simulation with the present invention.

During a step **200**, simulation begins by reading the reservoir and production data. Reservoir and production data read in during step **200** are of the types discussed above. The reservoir simulator is also initialized during step **200**, setting the simulation day and the time step to zero. During step **202** the time step is incremented by one, and an iteration counter of the number of non-linear iterations performed during the present time step is set to zero.

During step **204**, a Jacobian matrix of reservoir data is formed. In step **206**, a reduced system like that defined by the model R described above is formed according to the present

invention' and the matrix solved for bottom hole potential Φ_w in the manner described above. During step 208, the modified linear system matrix A is solved according to the present invention in the manner set forth above.

FIG. 15 illustrates the methodology of forming the reduced system matrix R and solving for bottom hole potential Φ_w according to steps 204 and 206 of FIG. 11. As indicated at step 210, vertical flow barriers in the original well system model are identified. This can be done based on well log data or by specification by a reservoir analyst from data in the original reservoir model.

After steps 210, a reduced system model is then formed by the data processing system D during a step 212. Those layers in the model which are located between flow barrier layers and have vertical flow are combined together for analytical model purposes.

Next, during step 214, the resulting reduced system is solved by computer processing for bottom hole potential Φ_w and residual unknowns using the techniques discussed of Equations (6) and (14) above. Step 216 then solves with the data processing system D the full system structural matrix of Equation (18) using a direct solver or other suitable technique described above. Completion rates q_c and total well flow rate q_T are then determined with the data processing system D based on the results of step 216.

Referring again to FIG. 11, during step 220, a convergence step is performed to determine whether the non-linear iterations have converged. The individual residuals of the equations resulting from step 216 are checked against user-specified tolerances. If these tolerances are satisfied, the non-linear iteration loop is exited the solution output is written to file for the current time step and processing returns to step 202 for the time step to be advanced, and processing for the incremented time step the proceeds as indicated. If the user-specified tolerances are determined not satisfied during step 208, processing according to the non-linear iteration loop returns to step 204 and continues. If the number on non-linear iterations becomes too large, a decision may be made to adjust the model.

As illustrated in FIG. 16, a data processing system D according to the present invention includes a computer 240 having a processor 242 and memory 244 coupled to the processor 242 to store operating instructions, control information and database records therein. The computer 240 may, if desired, be a portable digital processor, such as a personal computer in the form of a laptop computer, notebook computer or other suitable programmed or programmable digital data processing apparatus, such as a desktop computer. It should also be understood that the computer 240 may be a multi-core processor with nodes such as those from Intel Corporation or Advanced Micro Devices (AMD), or a mainframe computer of any conventional type of suitable processing capacity such as those available from International Business Machines (IBM) of Armonk, N.Y. or other source.

The computer 240 has a user interface 246 and an output display 248 for displaying output data or records of processing of well logging data measurements performed according to the present invention to obtain a measure of transmissibility of fluid in subsurface formations. The output display 48 includes components such as a printer and an output display screen capable of providing printed output information or visible displays in the form of graphs, data sheets, graphical images, data plots and the like as output records or images.

The user interface 246 of computer 240 also includes a suitable user input device or input/output control unit 250 to provide a user access to control or access information and database records and operate the computer 240. Data process-

ing system D further includes a database 252 stored in computer memory, which may be internal memory 244, or an external, networked, or non-networked memory as indicated at 254 in an associated database server 256.

The data processing system D includes program code 260 stored in memories 244 of the computer 240. The program code 260, according to the present invention is in the form of computer operable instructions causing the data processor 242 to form a sequential fully implicit well model for reservoir simulation according to the present invention in the manner that has been set forth.

It should be noted that program code 260 may be in the form of microcode, programs, routines, or symbolic computer operable languages that provide a specific set of ordered operations that control the functioning of the data processing system D and direct its operation. The instructions of program code 260 may be may be stored in memory 244 of the computer 240, or on computer diskette, magnetic tape, conventional hard disk drive, electronic read-only memory, optical storage device, or other appropriate data storage device having a computer usable medium stored thereon. Program code 260 may also be contained on a data storage device such as server 64 as a computer readable medium, as shown.

Two illustrative example model problems are presented below: a seven layer homogeneous reservoir with one flow barrier (FIG. 7); and a twenty-two layer heterogeneous reservoir with two flow barriers (FIG. 8).

Seven Layer Homogeneous Reservoir Model

FIG. 7A illustrates the seven reservoir layers and properties for the original model 70 and reduced model 71. As seen, it was assumed that reservoir has seven layers. Layer thickness of each layer 72 with vertical flow is 10 ft. A layer 73 which represents a fracture with no vertical flow is present which is 1 ft thick. It was further assumed that the layer 73 does not communicate with the layers 72 above and below. It was assumed that there is a vertical well in the middle, as indicated by an arrow. Initial reservoir potential (datum corrected pressure) is 3,000 psi for the model of FIG. 7A. Each layer 72 was assumed to have 10 md areal permeability k_x and k_y , 1 md vertical permeability k_z .

Table 1 summarizes the reservoir and grid properties for the model 70. The grid size in the area direction (square grid) was assumed to be 840 ft. Oil viscosity was set to 1 cp and Oil Formation Volume factor was assumed to be 1. Well Total Oil Production rate was set to 1,000 B/D. A Layer Productivity Index PI for each layer completion was calculated by Peaceman's method, as described below, and is also shown in Table 1.

TABLE 1

Problem 1 - Reservoir Properties				
Layer	Thickness, ft	$K_x = k_y$, md	K_z , md	Layer, PI b/d/psi
1	10.	10.	1	0.12
2	10.	10.	1	0.12
3	1	10,000	1.e-9	12.14
4	10	10	1	0.12
5	10	10	1	0.12
6	10	10	1	0.12
7	10	10	1	0.12

Fully Implicit Fully Coupled Simultaneous Solution

The coefficient matrix for the solution of reservoir pressures and the bottom hole pressure is formed in a similar

15

manner explained above with regard to Equation (3) and as shown in FIG. 3. It can be seen that there are only 8 unknowns (7 potentials or datum corrected pressures) and the one bottom hole potential), and that the coefficient matrix is non-sparse. The linear system of equations can be solved by a direct method, such as Gaussian Elimination, for the unknown reservoir (layer) potentials Φ_i , $i=1, 7$ and the other unknown Φ_w .

Results

Table 2 summarizes the calculated layer potentials, wellbore potential and layer (completion) flow rates for the model 70 of FIG. 7A.

TABLE 2

Exact Solution of the Original Problem (using full model)			
Layer	Potential, psi	Bottom hole (Wellbore) Potential, psi	Rate/d
1	2630.61	1257.36	166.67
2	2630.61	1257.36	166.67
3	1257.37	1257.36	0.0
4	2630.61	1257.36	166.67
5	2630.61	1257.36	166.67
6	2630.61	1257.36	166.67
7	2630.61	1257.36	166.67

From the computed results we see that computed bottom hole potential

$$\Phi_w=1257.36 \text{ psi.}$$

Formation of the Problem According to the Present Invention

According to the reservoir data in Table 1 and as shown in FIG. 7A, there is only one layer 73 which does not communicate vertically with the other layers. Therefore, as shown in FIG. 7B, the layers 72 above the fracture layer 73 are combined into a single layer according to form the reduced model in accordance with the present invention. Similarly layers 72 below layer 73 are combined into a single layer. The reduced model now can be seen to have only three layers. The total number of the unknowns is 4 as opposed to 8 as in the full model.

Table 3 summarizes the properties of reduced model 71 formed according to processing with the present invention.

TABLE 3

Reduced Model				
Layer	Thickness, ft	$K_x = K_y$, md	K_z , md	PI, b/d/psi
1	20	10	1	0.24
2	1	10,000	0	12.14
3	40	10	1	0.40

The linear system of equations (Equation 6) for the reduced system still has an unstructured coefficient matrix, but with a 50% less number of unknowns. In actual reservoirs, with hundreds of layers and only a few flow barriers, the model size reduction according to the present invention would be drastic, for example, a reduced system model according to the present invention could be 1 percent of size of the full system. The reduced system is solved by a direct solver for the layer potentials and the bottom hole potential. Table 4 presents the results.

16

TABLE 4

Results of The Reduced System		
Layer	Potential, psi	Bottom hole (Wellbore) Potential, psi
1	2630.61	1257.36
2	1257.37	1257.36
3	2630.61	1257.36

It can be seen that computed bottom hole potential:

$$\Phi_w=1257.36 \text{ psi}$$

is exactly the same as the Φ_w calculated for the full model.

The determined well potential is the only information needed for the next step. The well is next treated as a specified bottom hole pressure (potential) model. Computer processing according to the procedure described with the matrix of FIG. 13 and Equation (7) is followed to calculate the flow profile (layer rates) and the total well rate. In FIG. 13, lower diagonal solid line of the matrix represents $T_{Up,i}$ as defined by Equation (2), and the upper diagonal solid line of the matrix describes the elements called $T_{Down,i}$ as also defined by Equation (2). The central term $T_{C,i}$ is defined by Equation (5a) and the right hand side b_i is defined by Equation (5b).

The results are summarized in Table 5. It is to be noted that total calculated well rate is exactly same as input value of 1,000 b/d.

TABLE 5

Results for the Total System With the Present Invention		
Layer	Potential, psi	Rate/d
1	2630.61	166.67
2	2630.61	166.67
3	1257.37	0.0
4	2630.61	166.67
5	2630.61	166.67
6	2630.61	166.67
7	2630.61	166.67
Total		1,000.

Therefore the difference or error between well rates for the calculated and input well is zero for this case and there no need for an extra iteration. This is because of the fact that the reservoir was homogeneous and no upscaling errors were made while forming the reduced system. Matrix diagonal elements and right hand side are the same as in FIG. (12) i.e., lower diagonal solid line represents $T_{up,i}$ defined by Equation (2), upper diagonal solid line describes the elements called $T_{Down,i}$ described above. The central term $T_{C,i}$ defined by Equation (5a) and right hand side b_i defined by Equation (5b) on page 13.

The terms PI appear on FIG. 13 are the perforation productivity indexes for a square grid is defined by:

$$PI_i = 2\pi k_{x,i} \frac{\Delta z_i}{\ln(0.2\Delta x/r_w)}$$

where r_w is the well bore radius.

Comparison with the Explicit Well Model

In several reservoir simulators, semi implicit well models or explicit well models are used. If the formulation of the well

17

model is semi-implicit but it collapses to explicit in the pressure variable, this formulation collapses to explicit well models. The explicit well model is for this problem obtained by following the computer processing procedures for the matrix of FIG. 12 and Equation (3) above. In FIG. 12, the terms $T_{Down,i}$, $T_{Up,i}$ which appear on the diagonal elements are defined by equation (2), and $T_{C,i}$, b_i are defined by Equation (5a) and Equation (5b). FIG. 8A illustrates the seven reservoir layers and properties for an implicit well model **80** and FIG. **8B** an explicit well model **81**, of like structure to the model of FIGS. 7A and 7B. As seen it was assumed that reservoir has seven layers. Layers **82** each have a potential Φ of 2630 psi. A layer **83** which represents a fracture and was further assumed that does not communicate with the layers **72** above and below has a potential Φ of 1257 psi. It was assumed that there is a vertical well in the middle, as indicated by an arrow. FIGS. **8A** and **8B** compare the results of Implicit and Explicit Models. Computed perforation (layer) rates are summarized in Table 6.

TABLE 6

Comparison of Perforation (Layer) Rates for Different Well Models			
Layer/ Perforation	Exact Solution (Fully Implicit Fully Coupled Simultaneous Solution), Rate b/d	New Method Rate, b/d	Explicit Method Rate, b/d
1	166.67	166.67	9.43
2	166.67	166.67	9.73
3	0.0	0.0	943.40
4	166.67	166.67	9.43
5	166.67	166.67	9.43
6	166.67	166.67	9.43
7	166.67	166.67	9.43

As can be seen, the model **81** according to the explicit method is inaccurate; it totally miscalculates the perforation rate. The explicit model method assigns practically all the well production from the thin fracture layer **83** as indicated in FIG. **8B** since this layer has the highest productivity index.

The implicit methods (whether the computationally intensive fully implicit model or the reduced model according to the present invention) do not make such an assignment and instead determine that the layer **83** is not getting fluid support from the layers **82** above and below. The only fluid support a fracture layer of this type shown at **83** when present in an actual reservoir can get is from its planar neighboring cells. However, since the fracture layer is a very thin layer, transmissibility in these directions is by nature small. Therefore, the fracture layer cannot supply fluid at the rates simulated by the explicit model.

In fact, conventional implicit well models show that during the transient time the fracture layers support most of the well production as do the explicit methods. However, the layer pressure in layer **83** quickly declines and assumes the value of the uniform wellbore potential (constant bottom hole pressure). After the pressure declines, it reaches steady state, and the well production rate is in fact made by the contribution from the layers **82** above and below the vertical flow barrier **83**.

Twenty-Two Layer Heterogeneous Reservoir Model

A model grid system **90** includes twenty two layers as shown in FIG. 9. The location of high permeability fracture layers **6** and **12** as counted moving downward through the layer and indicated schematically at **91** and **92**. There are five

18

layers **93**, numbered **1** through **5** above layer **91**, each with vertical flow. There are also five layers **94** in the model **90** with vertical flow between the flow barrier layers **91** and **92**, and ten layers **95** with vertical flow located below the flow barrier layer **92**. Reservoir data for the model **90** is shown in Table 7.

TABLE 7

Reservoir Data for 22 Layer Problem			
Layer	Thickness, ft	Permeability, mD ($K_x = K_y$)	Vertical Permeability, K_z , mD
1	10	2	2
2	10	5	1
3	10	3	3
4	10	10	5
5	10	5	4
6	1	1,000.	1.e-9
7	10	6	6
8	10	3	3
9	10	9	6
10	10	12	2
11	10	5	5
12	1	1,000.	1.e-9
13	10	7.5	3.5
14	10	7.5	3.5
15	10	7.5	3.5
16	10	7.5	3.5
17	10	7.5	3.5
18	10	9.2	1.2
19	10	9.2	1.2
20	10	9.2	1.2
21	10	9.2	1.2
22	10	9.2	1.2

Areal neighboring cell permeabilities=20 mD
Total Well Production Rate=2,500 B/D
Well Completed in all layers.

Results

Fully Implicit Fully Coupled Simultaneous Solution
Calculated bottom hole potential $\Phi_w=1421.247$ psi

TABLE 8

Potential Distribution, psi		
Layer	Φ_w	Φ_l
1	1421.25	2901.32
2	1421.25	2900.82
3	1421.25	2900.38
4	1421.25	2900.38
5	1421.25	2900.38
6	1421.25	1421.25
7	1421.25	2864.43
8	1421.25	2864.37
9	1421.25	2864.10
10	1421.25	2863.88
11	1421.25	2864.03
12	1421.25	1421.25
13	1421.25	2841.62
14	1421.25	2841.58
15	1421.25	2841.48
16	1421.25	2841.33
17	1421.25	2841.13
18	1421.25	2840.65
19	1421.25	2840.08
20	1421.25	2839.65
21	1421.25	2839.37
22	1421.25	2839.24

The model **90** was then subjected to the explicit model techniques of the type described above and flow data deter-

19

mined. A comparison of flow rate distribution for fully implicit and explicit processing of the reservoir model 90 using techniques previously described is set forth in Table 9.

TABLE 9

Comparison of Flow Rates for Fully Implicit Fully Coupled and Explicit Methods		
Layer	Implicit/	Explicit
1	35.93	14.56
2	89.78	36.39
3	53.85	21.83
4	179.48	72.78
5	89.74	36.39
6	0.00	727.80
7	105.09	43.67
8	52.54	21.83
9	157.60	65.50
10	210.10	87.34
11	87.55	36.39
12	0.00	727.80
13	129.29	54.59
14	129.28	54.59
15	129.28	54.59
16	129.26	54.59
17	129.24	54.59
18	158.49	66.96
19	158.42	66.96
20	158.37	66.96
21	158.34	66.96
22	158.33	66.96

Reduced Model Construction

Since there are only two vertical flow barriers layers 91 and 92, layers 93 above layer 91 in FIG. 9 can be combined into one layer; layers 94 below layer 91 into one layer, and layers 95 below layer 92 into another single layer. Therefore the total number of layers according to the present invention is 5. The properties of the reduced model are as follows:

TABLE 10

Reduced Model Properties					
Layer	Thickness, ft	K_x , mD	K_z , mD	PI, b/d/psi	PI Fraction
1	50	5	2.19	0.3	0.07
2	1	1000	0	1.21	0.29
3	50	7	3.66	0.42	0.10
4	1	1000	0	1.21	0.29
5	100	8.35	1.79	1.01	0.24

Calculated Bottom Hole Potential

$\Phi_w=1421.34$ psi

The reduced model in accordance with the present invention the proceeds to determine bottom hole potential Φ_w . The results of the reduced model with five layers are set forth below in Table 11.

TABLE 11

Potential Distribution		
Layer	Pot wf	Pot
1	1421.34	2900.53
2	1421.34	1421.35

20

TABLE 11-continued

Potential Distribution		
Layer	Pot wf	Pot
3	1421.34	2864.16
4	1421.34	1421.35
5	1421.34	2840.61

Using the bottom hole Potential Φ_w calculated from the reduced model and computing potentials using specified bottom hole pressure Φ_w for the full model, completion layer rates are calculated according to Equation (8), The results are indicated below in Table 13.

TABLE 12

Calculated Rates		
Layer	New Method	Fully Coupled Method
1	35.92	35.93
2	89.78	89.78
3	53.85	53.48
4	179.47	179.47
5	89.73	89.73
6	0.00	0.00
7	105.09	105.09
8	52.54	52.54
9	157.59	157.60
10	210.09	210.10
11	87.55	87.55
12	0.00	0.00
13	129.28	129.29
14	129.28	129.28
15	129.27	129.28
16	129.25	129.26
17	129.24	129.24
18	158.48	158.49
19	158.41	158.42
20	158.37	158.37
21	158.33	158.34
22	158.32	158.33

Newly calculated qt 2499.84 b/d
Error= $2,500.-2499.8488=0.15$ b/d

The present invention obtains a reduced model with a production rate acceptably accurate in comparison to the results obtained by the fully implicit, fully coupled processing techniques of the prior art, but with a substantial reduction in model complexity and computer processing time.

The present invention, as has been described above, does not require a special linear solver for the solution of the coupled reservoir and well equations. In contrast, the coefficient matrix for the previously used coupled reservoir and well equations does not have regular sparse structure. Therefore, the conventional types of coupled reservoir and well equations require special solvers which can be expensive and can also face convergence problems.

It can be seen that, as described above, the present invention does not require any special solver for the solution of coupled reservoir and well equations. The same solver used for reservoir equations is utilized. The only modification made to the coefficient matrix is in the diagonal terms.

The present invention solves reservoir simulation problems where the vertical wells have many completions, which is a common occurrence in reservoirs. In recent simulation studies wells with more than 100 vertical layers (completions) are very common. The fully coupled fully implicit well model with simultaneous solution is very expensive for these cases. The present invention can save significant amounts of computer time.

The present invention is very useful for wells having hundreds of perforations completed in highly heterogeneous reservoirs. The present invention reduces the large, time consuming problem of well modeling simulation in reservoirs with large numbers of layers (completions) problem to a small problem by recognizing and advantageously using the physical principles involved. With the present invention, it has been found that vertically communicating layers can be lumped into a single layer. The reduced model so formed preserves the same bottom hole pressure as the original full model. Once the reduced model is solved for the bottom hole pressure, the wells in the large system are then treated as specified bottom hole pressure and solved easily by a conventional linear solver. Thus, the present invention eliminates the need for writing or acquiring unstructured linear solvers for many wells with hundreds of completions which would be expensive.

The invention has been sufficiently described so that a person with average knowledge in the matter may reproduce and obtain the results mentioned in the invention herein. Nonetheless, any skilled person in the field of technique, subject of the invention herein, may carry out modifications not described in the request herein, to apply these modifications to a determined structure, or in the manufacturing process of the same, requires the claimed matter in the following claims; such structures shall be covered within the scope of the invention.

It should be noted and understood that there can be improvements and modifications made of the present invention described in detail above without departing from the spirit or scope of the invention as set forth in the accompanying claims.

The invention claimed is:

1. A computer implemented method of forming a model of determined well completion rates of component fluids of a subsurface reservoir from measured total well production by reservoir simulation of well production, at a time step during life of the subsurface reservoir, from a vertical well in the subsurface reservoir with a coupled well reservoir simulator model, the reservoir simulator model having formation layers having unknown formation pressures and completion rates at the time step, the formation layers comprising vertical fluid flow layers having vertical fluid flow therefrom and flow barrier layers with no vertical fluid flow therefrom, the coupled well reservoir simulator model being organized into a plurality of cells including a plurality of well cells at locations of the vertical well in formation layers of the reservoir, and a plurality of reservoir cells adjacent the well and having unknown formation pressures and completion rates at the time step, the method comprising the computer implemented steps of:

forming a reduced system model consisting of:

interval well cells between flow barrier layers of the reservoir assembled by combining vertically disposed well cells of the vertical flow formation layers having vertical fluid communication therebetween and being located between flow barrier layers in the coupled reservoir model; and

reservoir cells adjacent the interval well cells;

solving the reduced system model for a bottom hole pressure of the well;

solving by reservoir simulation the coupled well reservoir model of the well cells and reservoir cells for layer completion rates of component fluids of the well cells of each of the formation layers of the coupled well reservoir model at the time step, treating the well as having the determined bottom hole pressure of the well;

determining a simulator total well production rate for the well from the layer completion rates of the component fluids of the formation layers of the coupled reservoir model of the well at the time step;

comparing the simulator total well production rate for the well with the measured total well production at the time step to determine if simulator convergence is achieved; and, if so,

forming a record of the layer completion rates of the component fluids for the layers at the well cells and of the determined total well production rate for the well at the time step; and

if the results of the step of comparing indicate convergence is not achieved, iterating to the step of solving by reservoir simulation the coupled well reservoir model, determining a simulator total well production rate for the well from the well completion rates of the component fluids, and comparing.

2. The computer implement method of claim 1, wherein the reservoir model has a plurality of flow barrier layers vertically spaced from each other by vertically disposed well cells and wherein the step of assembling comprises assembling as separate interval well cells the interval well cells between vertically adjacent pairs of the vertically spaced flow barrier layers.

3. The method of claim 1, wherein the step of forming a record comprises the step of storing in computer memory the determined layer completion rates for the component fluids of the well and the determined total well production rate for the well at the time step.

4. The method of claim 1, wherein the step of forming a record comprises the step of forming an output display of the determined layer completion rates for the component fluids of the well and the determined total well production rate for the well at the time step.

5. The method of claim 1, further including the step of identifying the flow barrier layers in the reservoir.

6. The computer implement method of claim 1, wherein the coupled well reservoir model has a plurality of wells and wherein the method comprises the steps of:

performing the steps of solving the reduced system model, solving by reservoir simulation the coupled well reservoir model, determining layer completion rates, determining a simulator total well production rate, comparing, and forming a record for each of the plurality of wells.

7. The computer implemented method of claim 1, wherein the component fluids comprise hydrocarbons and water.

8. The computer implemented method of claim 1, wherein the coupled well reservoir model is formed as a structured matrix and the step of solving by reservoir simulation comprises the step of:

solving the coupled well reservoir model structured matrix.

9. The computer implemented method of claim 1, wherein the step of comparing the simulator total well production rate for the well with the measured total well production rate for the well indicates convergence is achieved, and further including the steps of:

incrementing the simulator time step: and

repeating for the incremented time step the steps of forming a reduced system model, solving the reduced system model for a bottom hole pressure of the well, solving by reservoir simulation the coupled well reservoir model, determining a simulator total well production rate for the well from the well completion rates of the component fluids, and comparing.

10. A data processing system for forming a model of determined well completion rates of component fluids of a subsurface reservoir from measured total well production by reservoir simulation of well production, at a time step during life of the reservoir, from a vertical well in the subsurface reservoir with a coupled well reservoir simulator model, the reservoir simulator model having formation layers having unknown formation pressures and completion rates at the time step, the formation layers comprising vertical fluid flow layers having vertical fluid flow therefrom and flow barrier layers with no vertical fluid flow therefrom, the coupled well reservoir simulator model being organized into a plurality of cells including a plurality of well cells at locations of the vertical well in formation layers of the reservoir, and a plurality of reservoir cells adjacent the well and having unknown formation pressures and completion rates at the time step, the data processing system comprising:

a processor performing the steps of:

forming a reduced system model consisting of:

interval well cells between flow barrier layers of the reservoir assembled by combining vertically disposed well cells of the vertical flow formation layers having vertical fluid communication therebetween and being located between flow barrier layers in the coupled reservoir model; and

reservoir cells adjacent the interval well cells;

solving the reduced system model for a bottom hole pressure of the well;

solving by reservoir simulation the coupled well reservoir model of well cells and reservoir cells for layer completion rates of component fluids of the well cells of each of the formation layers of the coupled well reservoir model at the time step, treating the well as having the determined bottom hole pressure of the well;

determining a simulator total well production rate for the well from the layer completion rates of the component fluids of the formation layers of the coupled reservoir model of the well at the time steps; and, if so, writing to memory a record of the layer completion rates of the component fluids for the layers at the well cells and of the determined total well production rate for the well at the time step; and

if the results of the step of comparing indicate convergence is not achieved, iterating to the step of solving by reservoir simulation the coupled well reservoir model, determining a simulator total well production rate for the well from the well completion rates of the component fluids, and comparing; and the data processing system further including

a memory forming a record of the layer completion rates for the component fluids for the layers at the well cells and of the determined total well production rate for the well at the time step.

11. The data processing system of claim **10**, further including:

a display forming an output image of the layer completion rates for the component fluids for the layers at the well cells and of the determined total well production rate for the well at the time step.

12. The data processing system of claim **10**, wherein the reservoir model has a plurality of flow barrier layers vertically spaced from each other by vertically disposed well cells and wherein the processor in performing the step of assembling assembles as separate interval well cells the interval well cells between vertically adjacent pairs of the vertically spaced flow barrier layers.

13. The data processing system of claim **10**, further including the processor performing step of identifying the flow barrier layers in the reservoir.

14. The data processing system of claim **10**, wherein the coupled well reservoir simulator model has a plurality of wells and wherein the processor performs the steps of solving the reduced system model, determining a simulator total well production rate, comparing, and forming a record for each of the plurality of wells.

15. The data processing system of claim **10**, wherein the component fluids comprise hydrocarbons and water.

16. The data processing system of claim **10**, wherein the coupled well reservoir model is formed as a structured matrix and the processor in performing the step of solving by reservoir simulation performs the step of:

solving the coupled well reservoir model structured matrix.

17. The data processing system of claim **10**, wherein the processor during the step of comparing the simulator total well production rate for the well with the measured total well production rate for the well indicates convergence is achieved, and the processor further performs the steps of:

incrementing the simulator time step: and

repeating for the incremented time step the steps of forming a reduced system model, solving the reduced system model for a bottom hole pressure of the well, solving by reservoir simulation the coupled well reservoir model, determining a simulator total well production rate for the well from the well completion rates of the component fluids, and comparing.

18. A data storage device having stored in a non-transitory computer readable medium computer operable instructions for causing a data processor, in forming a model of determined well completion rates of component fluids of a subsurface reservoir from measured total well production by reservoir simulation of well production, at a time step during life of the subsurface reservoir, from a vertical well in the subsurface reservoir with a coupled well reservoir simulator model, the reservoir simulator model having formation layers having unknown formation pressures and completion rates at the time step, the formation layers comprising vertical fluid flow layers having vertical fluid flow therefrom and flow barrier layers with no vertical fluid flow therefrom, the coupled well reservoir simulator model being organized into a plurality of cells including a plurality of well cells at locations of the vertical well in formation layers of the reservoir, and a plurality of reservoir cells adjacent the well and having unknown formation pressures and completion rates at the time step, to perform a sequence of steps comprising:

forming a reduced system model consisting of:

interval well cells between flow barrier layers of the reservoir assembled by combining vertically disposed well cells of the vertical flow formation layers having vertical fluid communication therebetween and being located between flow barrier layers in the coupled reservoir model; and

reservoir cells adjacent the interval well cells;

solving the reduced system model for a bottom hole pressure of the well;

solving by reservoir simulation the coupled well reservoir model of well cells and reservoir cells for layer completion rates of component fluids of the well cells of each of the formation layers of the coupled well reservoir at the time step, treating the well as having the determined bottom hole pressure of the well;

determining a simulator total well production rate for the well from the layer completion rates of the component

25

fluids of the formation layers of the coupled reservoir model of the well at the time step; and, if so, forming a record the layer completion rates of the component fluids for the layers at the well cells and of the determined total well production rate for the well at the time step; and

if the results of the step of comparing indicate convergence is not achieved, iterating to the step of solving by reservoir simulation the coupled well reservoir model, determining a simulator total well production rate for the well from the well completion rates of the component fluids, and comparing.

19. The data storage device of claim 18, wherein the coupled well reservoir model has a plurality of flow barrier layers vertically spaced from each other by vertically disposed well cells and wherein the stored instructions for the step of assembling comprise instructions for assembling as separate interval well cells the interval well cells between vertically adjacent pairs of the vertically spaced flow barrier layers.

20. The data storage device of claim 18, further including the stored instructions comprising instructions causing the processor to perform the step of identifying the flow barrier layers in the reservoir.

26

21. The data storage device of claim 18, wherein the component fluids comprise hydrocarbons and water.

22. The data storage device of claim 18, wherein the coupled well reservoir model is formed as a structured matrix and the instructions for the step of solving by reservoir simulation further include instructions causing the data processor to perform the step of:

solving the coupled well reservoir model structured matrix.

23. The data storage device of claim 18, wherein comparing the simulator total well production rate for the well with the measured total well production rate for the well indicates convergence is achieved, and wherein the stored instructions further include instructions causing the processor to perform the steps of:

incrementing the simulator time step: and

repeating for the incremented time step the steps of forming a reduced system model, solving the reduced system model for a bottom hole pressure of the well, solving by reservoir simulation the coupled well reservoir model, determining a simulator total well production rate for the well from the well completion rates of the component fluids, and comparing.

* * * * *

UNITED STATES PATENT AND TRADEMARK OFFICE
CERTIFICATE OF CORRECTION

PATENT NO. : 9,164,191 B2
APPLICATION NO. : 13/023728
DATED : October 20, 2015
INVENTOR(S) : Ali H. Dogru

Page 1 of 1

It is certified that error appears in the above-identified patent and that said Letters Patent is hereby corrected as shown below:

In the Claims

In Column 22, Line 20, Claim 2, third word appears as “implement” and should read --implemented--.

In Column 22, Line 20, Claim 2, the last word appears as “the” and should read --the coupled well--.

In Column 22, Line 39, Claim 6, the third word appears as “implement” and should read --implemented--.

In Column 23, Line 62, Claim 12, the first word appears as “reservoir” and should read --coupled well reservoir--.

Signed and Sealed this
Seventh Day of June, 2016



Michelle K. Lee
Director of the United States Patent and Trademark Office