



US009131528B2

(12) **United States Patent**
Zhang et al.

(10) **Patent No.:** **US 9,131,528 B2**
(45) **Date of Patent:** **Sep. 8, 2015**

(54) **PHYSICAL LAYER FRAME FORMAT FOR WLAN**

(71) Applicant: **MARVELL WORLD TRADE LTD.**,
St. Michael (BB)

(72) Inventors: **Hongyuan Zhang**, Fremont, CA (US);
Sudhir Srinivasa, Sunnyvale, CA (US);
Rohit U. Nabar, Sunnyvale, CA (US);
Raja Banerjea, Sunnyvale, CA (US)

(73) Assignee: **MARVELL WORLD TRADE LTD.**,
St. Michael (BB)

(*) Notice: Subject to any disclaimer, the term of this patent is extended or adjusted under 35 U.S.C. 154(b) by 101 days.

(21) Appl. No.: **13/856,277**

(22) Filed: **Apr. 3, 2013**

(65) **Prior Publication Data**

US 2013/0259017 A1 Oct. 3, 2013

Related U.S. Application Data

(60) Provisional application No. 61/619,640, filed on Apr. 3, 2012.

(51) **Int. Cl.**
H04W 84/02 (2009.01)
H04L 1/00 (2006.01)

(52) **U.S. Cl.**
CPC **H04W 84/02** (2013.01); **H04L 1/009** (2013.01); **H04L 1/0041** (2013.01); **H04L 1/0061** (2013.01); **H04L 1/0072** (2013.01); **H04L 1/0079** (2013.01)

(58) **Field of Classification Search**
CPC H04W 84/02; H04L 1/0041; H04L 1/0061
USPC 370/338
See application file for complete search history.

(56) **References Cited**

U.S. PATENT DOCUMENTS

7,478,314 B1 1/2009 Cheong et al.
7,599,332 B2 10/2009 Zelst et al.

(Continued)

FOREIGN PATENT DOCUMENTS

WO WO-2012/122119 A1 9/2012
WO WO-2013/152111 A1 10/2013
WO WO-2014/183059 A1 11/2014

OTHER PUBLICATIONS

International Preliminary Report on Patentability in corresponding International Application No. PCT/US2013/035132 dated Oct. 7, 2014 (7 pages).

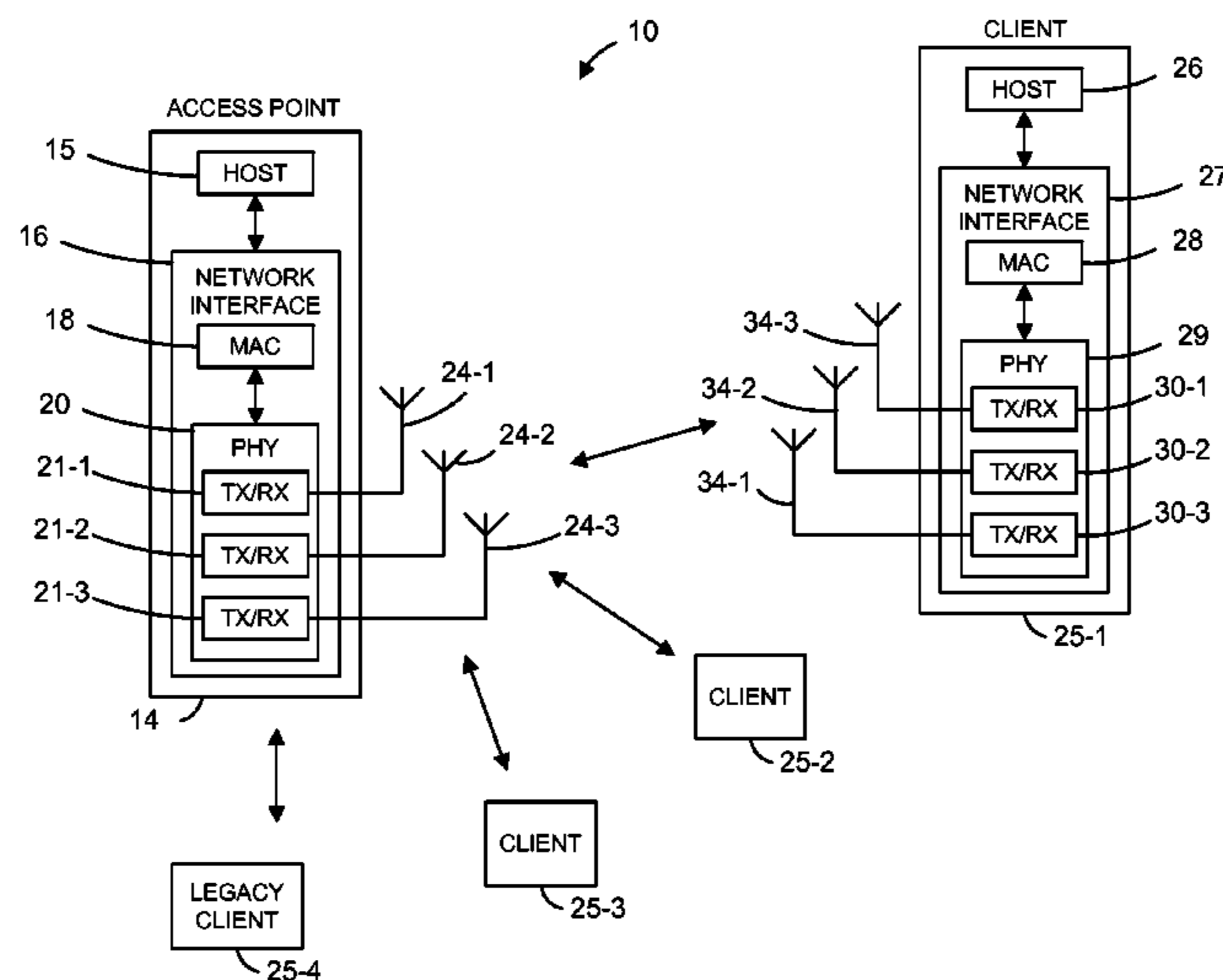
(Continued)

Primary Examiner — Sai-Ming Chan

(57) **ABSTRACT**

In a method for generating a data unit conforming to a first communication protocol, a first field and a second field to be included in a preamble of the data unit are generated. The first field includes a first set of one or more information bits that indicate a duration of the data unit and is formatted such that the first field allows a receiver device that conforms to a second communication protocol to determine the duration of the data unit. The second field includes a second set of one or more information bits that indicate to a receiver device that conforms to the first communication protocol that the data unit conforms to the first communication protocol. The first field and the second field are modulated using a modulation scheme specified for a field corresponding to the first field and the second field, respectively, by the second communication protocol.

8 Claims, 16 Drawing Sheets



(56)

References Cited

U.S. PATENT DOCUMENTS

7,742,390	B2	6/2010	Mujtaba	
7,974,225	B2	7/2011	Kasher	
8,144,647	B2	3/2012	Nabar et al.	
8,201,065	B1	6/2012	Cheong et al.	
8,619,907	B2	12/2013	Mujtaba et al.	
8,627,171	B2	1/2014	Pi	
8,681,757	B2	3/2014	Lee et al.	
2009/0196163	A1	8/2009	Du	
2010/0046358	A1	2/2010	van Nee	
2010/0046656	A1*	2/2010	van Nee et al.	375/267
2010/0091673	A1	4/2010	Sawai et al.	
2010/0260159	A1*	10/2010	Zhang et al.	370/338
2010/0309834	A1	12/2010	Fischer et al.	
2011/0002219	A1	1/2011	Kim et al.	
2011/0032875	A1	2/2011	Erceg et al.	
2012/0195391	A1	8/2012	Zhang et al.	
2012/0201316	A1	8/2012	Zhang et al.	
2012/0294294	A1	11/2012	Zhang	
2012/0300874	A1	11/2012	Zhang	
2012/0327871	A1	12/2012	Ghosh et al.	
2013/0202001	A1	8/2013	Zhang	
2014/0337690	A1	11/2014	Zhang	

OTHER PUBLICATIONS

Gunnam, et al., "Multi-Rate Layered Decoder Architecture for Block LDPC Codes of the IEEE 802.11n Wireless Standard," IEEE International Symposium on Circuits and Systems, 2007 (ISCAS 2007), pp. 1645-1648 (2007).

IEEE Std 802.11a-1999 (Supplement to IEEE Std 802.11-1999) "Supplement to IEEE Standard for Information technology—Telecommunications and information exchange between systems—Local and metropolitan area networks—Specific requirements—Part 11: Wireless LAN Medium Access Control (MAC) and Physical Layer (PHY) specifications: High-Speed Physical Layer in the 5 GHz Band," *The Institute of Electrical and Electronics Engineers, Inc.*, (1999).

IEEE Std 802.11ac/D2.1 "Draft STANDARD for Information Technology—Telecommunications and information exchange between systems—Local and metropolitan area networks—Specific requirements, Part 11: Wireless LAN Medium Access Control (MAC) and Physical Layer (PHY) specifications: Amendment 4: Enhancements for Very High Throughput for Operation in Bands below 6 GHz," *The Institute of Electrical and Electronics Engineers, Inc.*, Mar. 2012.

IEEE Std 802.11ac/D2.0 "Draft STANDARD for Information Technology—Telecommunications and information exchange between systems—Local and metropolitan area networks—Specific requirements, Part 11: Wireless LAN Medium Access Control (MAC) and Physical Layer (PHY) specifications: Amendment 4: Enhancements for Very High Throughput for Operation in Bands below 6 GHz," *The Institute of Electrical and Electronics Engineers, Inc.*, Jan. 2012.

IEEE Std 802.11b-1999/Cor Jan. 2001 (Corrigendum to IEEE Std 802.11b-1999) "IEEE Standard for Information technology—Telecommunications and information exchange between systems—Local and metropolitan area networks—Specific requirements, Part 11: Wireless LAN Medium Access Control (MAC) and Physical Layer (PHY) specifications, Amendment 2: Higher-speed Physical Layer (PHY) extension in the 2.4 GHz band-Corrigendum 1," *The Institute of Electrical and Electronics Engineers, Inc.*, Nov. 7, 2001.

International Standard, ISO/IEC 8802-11, ANSI/IEEE Std 802.11, "Information technology—Telecommunications and information exchange between systems—local and metropolitan area networks—specific requirements" Part 11: Wireless LAN Medium Access Control (MAC) and Physical Layer (PHY) specifications, *The Institute of Electrical and Electronics Engineers, Inc.*, (1999).

IEEE Std 802.11a-1999 (R2003) (Supplement to IEEE Std 802.11-1999) "Supplement to IEEE Standard for Information technology—Telecommunications and information exchange between systems—Local and metropolitan area networks—Specific requirements—Part 11: Wireless LAN Medium Access Control (MAC) and Physical Layer (PHY) specifications: High-Speed Physical Layer in the 5 GHz

Band," *The Institute of Electrical and Electronics Engineers, Inc.*, (1999) Reaffirmed Jun. 12, 2003.

S. A. Mujtaba, "IEEE P802.11—Wireless LANs, TGn Sync Proposal Technical Specification," *The Institute of Electrical and Electronics Engineers, Inc.*, doc.: IEEE 802.11-04/0889r6, May 2005.

"IEEE P802.11n™/D3.00, Draft STANDARD for Information Technology—Telecommunications and information exchange between systems—Local and metropolitan area networks—Specific requirements, Part 11: Wireless LAN Medium Access Control (MAC) and Physical Layer (PHY) specifications: Amendment 4: Enhancements for Higher Throughput," *The Institute of Electrical and Electronics Engineers, Inc.*, Sep. 2007.

Syafei et al., "Design of 1.2 Gbps MIMO WLAN System for 4K Digital Cinema Transmission," IEEE 20th Int'l Symposium on Personal, Indoor and Mobile Radio Communications (PIMRC 2009), *The Institute of Electrical and Electronics Engineers*, pp. 207-211 (2009).

Imashioya et al., "RTL Design of 1.2 Gbps MIMO WLAN System and Its Business Aspect," IEEE 9th Int'l Symposium on Communications and Information Technology (ISCIT 2009), *The Institute of Electrical and Electronics Engineers*, pp. 296-301 (2009).

Syafei et al., "A Design of Next Generation Gigabit MIMO Wireless LAN System," IEEE 12th Int'l Conference on Advanced Communication Technology (ICACT 2010), *The Institute of Electrical and Electronics Engineers*, pp. 941-946 (2010).

Syafei et al., "A Gigabit MIMO WLAN System with International Standardization Strategy," IEEE Int'l Symposium on Intelligent Signal Processing and Communication Systems (ISPACS 2009), *The Institute of Electrical and Electronics Engineers*, pp. 228-231 (2009).

Shi et al., "Phase Tracking During VHT-LTF," Doc. No. IEEE 802.11-10/0771r0, *The Institute of Electrical and Electronics Engineers, Inc.*, Jul. 2010.

van Zelst et al., "Pilot Sequence for VHT-DATA," Doc. No. IEEE 802.11-10/0811r1, *The Institute of Electrical and Electronics Engineers, Inc.*, Jul. 2010.

IEEE Std 802.11af/D1.05 "Draft Standard for Information Technology—Telecommunications and information exchange between systems—Local and metropolitan area networks—Specific requirements, Part 11: Wireless LAN Medium Access Control (MAC) and Physical Layer (PHY) specifications: Amendment 4: TV White Spaces Operation," *The Institute of Electrical and Electronics Engineers, Inc.*, Nov. 2011.

Vermani, et al. "Preamble Format for 1 MHz," *The Institute of Electrical and Electronics Engineers*, doc. No. IEEE 802.11-11/1482r2, (Nov. 2011).

International Search Report issued in corresponding PCT/US2013/035132, mailed Jun. 24, 2013.

Written Opinion issued in corresponding PCT/US2013/035132, mailed Jun. 24, 2013.

IEEE Std 802.11b-1999 (Supplement to ANSI/IEEE Std 802.11, 1999 Edition) "Supplement to IEEE Standard for Information technology—Telecommunications and information exchange between systems—Local and metropolitan area networks—Specific requirements Part 11: Wireless LAN Medium Access Control (MAC) and Physical Layer (PHY) specifications: Higher-speed Physical Layer Extension in the 2.4 GHz Band," *The Institute of Electrical and Electronics Engineers, Inc.*, pp. 1-89 (Sep. 1999).

IEEE Std 802.11g/D2.8, May 2002 (Supplement to ANSI/IEEE Std 802.11, 1999 Edition) "Draft Supplement to Standard [for] Information technology—Telecommunications and information exchange between systems—Local and metropolitan area networks—Specific requirements—Part 11: Wireless LAN Medium Access Control (MAC) and Physical Layer (PHY) specifications: Further Higher-Speed Physical Layer Extension in the 2.4 GHz Band," *The Institute of Electrical and Electronics Engineers, Inc.*, pp. 1-53 (May 2002).

IEEE Std 802.11g/D8.2, Apr. 2003 (Supplement to ANSI/IEEE Std 802.11, 1999 (Reaff 2003)) "Draft Supplement to Standard [for] Information technology—Telecommunications and information exchange between systems—Local and metropolitan area networks—Specific requirements, Part 11: Wireless LAN Medium Access Control (MAC) and Physical Layer (PHY) specifications:

(56)

References Cited

OTHER PUBLICATIONS

Further Higher Data Rate Extension in the 2.4 GHz Band,” *The Institute of Electrical and Electronics Engineers, Inc.*, pp. 1-69 (Apr. 2003).

IEEE Std. 802.11n™ “IEEE Standard for Information Technology—Telecommunications and information exchange between systems—Local and metropolitan area networks—Specific requirements, Part 11: Wireless LAN Medium Access Control (MAC) and Physical Layer (PHY) Specifications: Amendment 5: Enhancements for Higher Throughput,” *The Institute of Electrical and Electronics Engineers, Inc.*, pp. 1-535 (Oct. 2009).

Cheong, et al., “Methods, Algorithms, Software, Circuits, Receivers and Systems for Decoding Convolutional Code,” U.S. Appl. No. 13/871,520, filed Apr. 26, 2013.

Francis, Michael, “Viterbi Decoder Block Decoding—Trellis Termination and Tail Biting,” Xilinx XAPP551 v2.0, pp. 1-21 (Jul. 30, 2010).

van Nee, et al. “The 802.11n MIMO-OFDM Standard for Wireless LAN and Beyond,” *Wireless Personal Communications*, vol. 37, pp. 445-453 (Jun. 2006).

Invitation to Pay Additional Fees and Partial International Search Report for PCT Application No. PCT/US2014/037534, 9 pages (Aug. 21, 2014).

International Search Report and Written Opinion in International Application No. PCT/US2014/037534, dated Oct. 21, 2014 (21 pages).

IEEE Std 802.11ac/D3.0 “Draft STANDARD for Information Technology—Telecommunications and information exchange between systems—Local and metropolitan area networks—Specific requirements, Part 11: Wireless LAN Medium Access Control (MAC) and Physical Layer (PHY) specifications: Amendment 4: Enhancements for Very High Throughput for Operation in Bands below 6 GHz,” *The Institute of Electrical and Electronics Engineers, Inc.*, pp. 1-385 (Jun. 2012).

IEEE Std 802.11ac/D4.0 “Draft STANDARD for Information Technology—Telecommunications and information exchange between systems—Local and metropolitan area networks—Specific requirements, Part 11: Wireless LAN Medium Access Control (MAC) and Physical Layer (PHY) specifications: Amendment 4: Enhancements for Very High Throughput for Operation in Bands below 6 GHz,” *The Institute of Electrical and Electronics Engineers, Inc.*, pp. 1-408 (Oct. 2012).

IEEE Std 802.11ac/D5.0 “Draft Standard for Information Technology—Telecommunications and information exchange between systems—Local and metropolitan area networks—Specific requirements, Part 11: Wireless LAN Medium Access Control (MAC) and Physical Layer (PHY) specifications: Amendment 4: Enhancements for Very High Throughput for Operation in Bands below 6 GHz,” *The Institute of Electrical and Electronics Engineers, Inc.*, pp. 1-440 (Jan. 2013).

de Vegt, “Potential Compromise for 802.11ah Use Case Document”, Institute of Electrical and Electronics Engineers, doc. No. IEEE 802.11-11/0457r0, pp. 1-27 (Mar. 2011).

Lee et al., “TGaf PHY proposal,” The Institute of Electrical and Electronics Engineers, doc. No. IEEE 802.11-12/0809r5, pp. 1-43 (Jul. 10, 2012).

Park, “Proposed Specification Framework for TGah,” The Institute of Electrical and Electronics Engineers, doc. No. IEEE 802.11--yy/xxxxr05, pp. 1-12 (Jan. 2012).

Park, “Proposed Specification Framework for TGah,” The Institute of Electrical and Electronics Engineers, doc. No. IEEE 802.11-11/1137r6, pp. 1-13 (Mar. 2012).

Park, Proposed Specification Framework for TGah D9.x., The Institute of Electrical and Electronics Engineers, doc. No. IEEE 802.11-yy/xxxxr0, pp. 1-30 (Jul. 2012).

Park, “Proposed Specification Framework for TGah,” The Institute of Electrical and Electronics Engineers, doc. No. IEEE 802.11-11/1137r11, pp. 1-36 (Sep. 2012).

Park, “Specification Framework for TGah,” The Institute of Electrical and Electronics Engineers, doc. No. IEEE 802.11-11/1137r13, pp. 1-58 (Jan. 14, 2013).

Perahia, et al., “Gigabit Wireless LANs: an overview of IEEE 802.11ac and 802.11ad,” *ACM Sigmobile Mobile Computing and Communications Review*, vol. 15, No. 3, pp. 23-33 (Jul. 2011).

Shao, “Channel Selection for 802.11ah,” doc.: IEEE 802.11-12/0816r0, pp. 1-11 (Jul. 2012).

Stacey et al., “IEEE P802.11, Wireless LANs, Proposed TGac Draft Amendment,” Institute of Electrical and Electronics Engineers, doc. No. IEEE 802.11-10/1361r3 pp. 1-154 (Jan. 2011).

Stacey et al., “Specification Framework for TGac,” document No. IEEE 802.11-09/0992r20, *Institute for Electrical and Electronics Engineers*, pp. 1-49, (Jan. 18, 2011).

Taghavi et al., “Introductory Submission for TGah,” doc. No. IEEE 802.11-11/0062r0, Institute for Electrical and Electronics Engineers, pp. 1-5 (Jan. 14, 2011).

Vermani, et al. “Spec Framework Text for PHY Numerology,” The Institute of Electrical and Electronics Engineers, doc. No. IEEE 802.11-11/1311r0, pp. 1-5 (Sep. 2011).

Vermani, et al. “Preamble Format for 1 MHz,” The Institute of Electrical and Electronics Engineers, doc. No. IEEE 802.11-11/1482r2, pp. 1-30 (Nov. 2011).

Yu et al., “Coverage extension for IEEE802.11ah,” The Institute of Electrical and Electronics Engineers, doc. No. IEEE 802.11-11/0035r1, pp. 1-10 (Jan. 2011).

Zhang et al., “11ah Data Transmission Flow,” The Institute of Electrical and Electronics Engineers, doc. No. IEEE 802.11-11/1484r1, pp. 1-15 (Nov. 2011).

Zhang et al., 1 MHz Waveform in Wider BW, The Institute of Electrical and Electronics Engineers, doc. No. IEEE 802.11-12/0309r1, pp. 1-10 (Mar. 2012).

Zhang et al., “Beamforming Feedback for Single Stream,” The Institute of Electrical and Electronics Engineers, doc. No. IEEE 802.11-12/1312r0, pp. 1-22 (Nov. 12, 2012).

* cited by examiner

FIG. 1

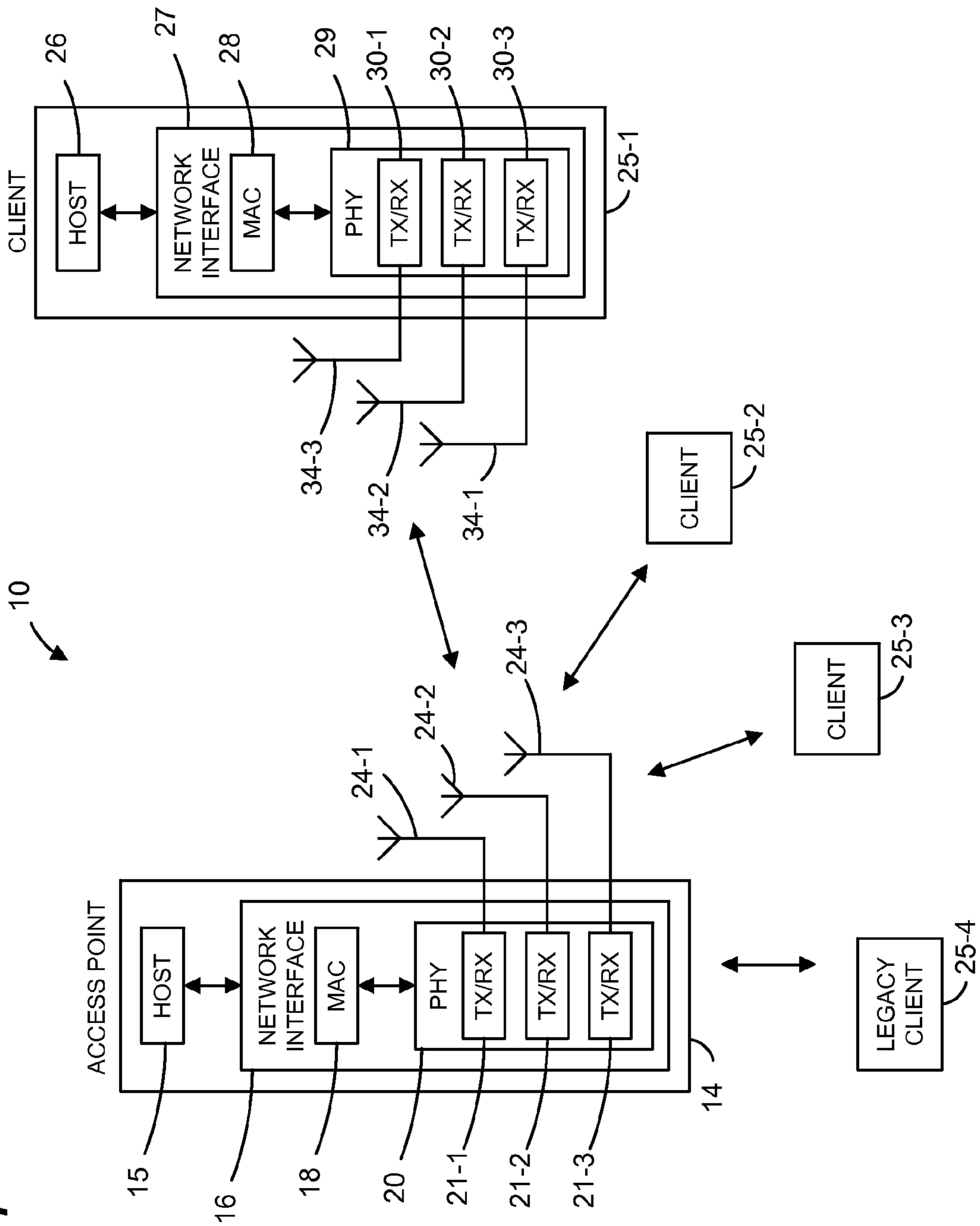


FIG. 2A

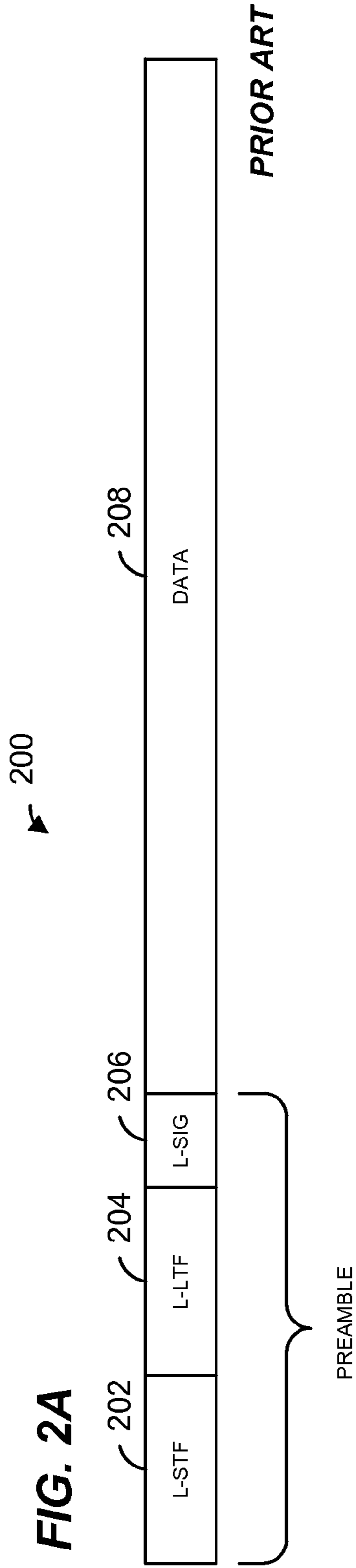


FIG. 2B

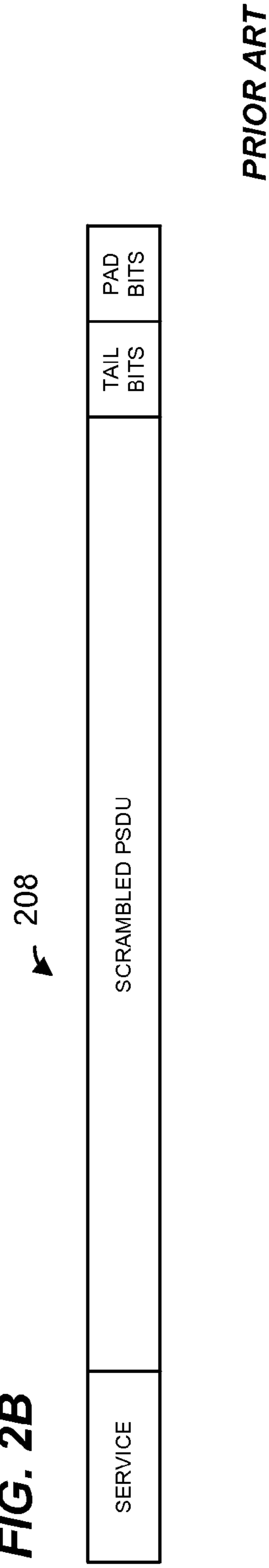


FIG. 3

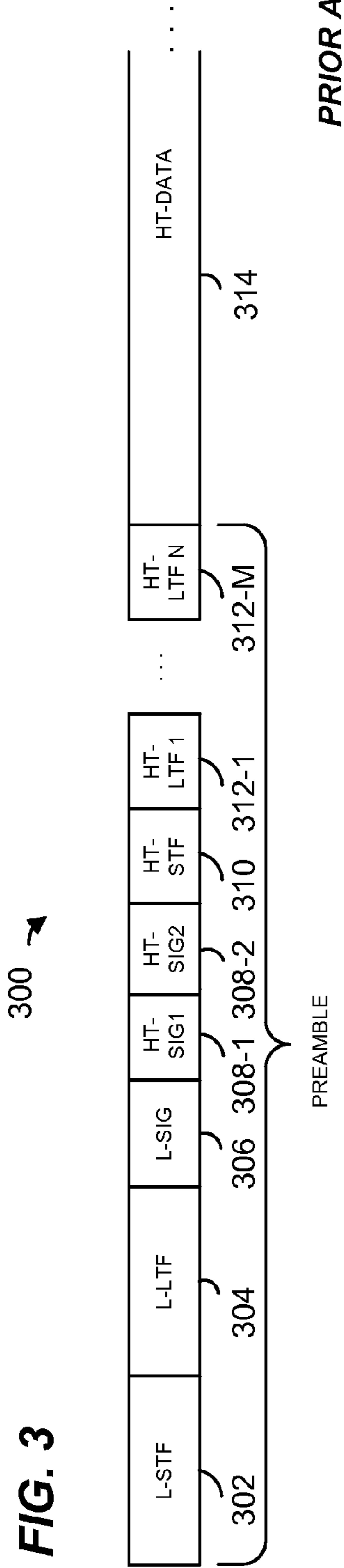


FIG. 4

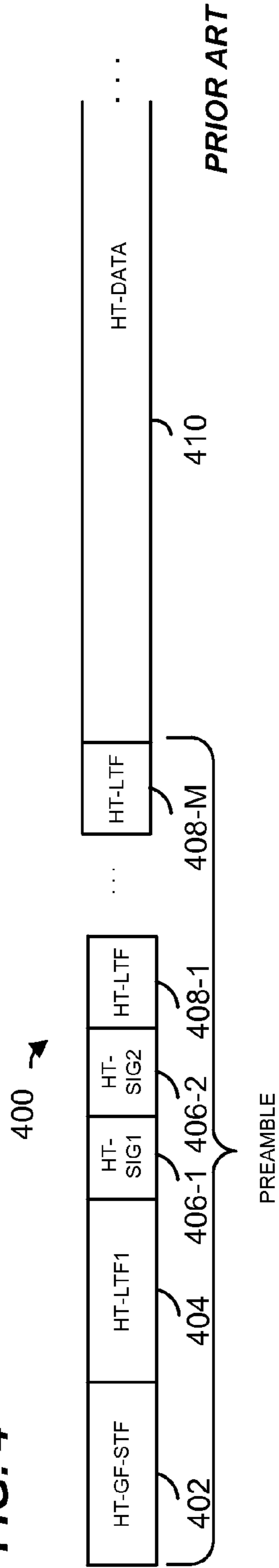


FIG. 5

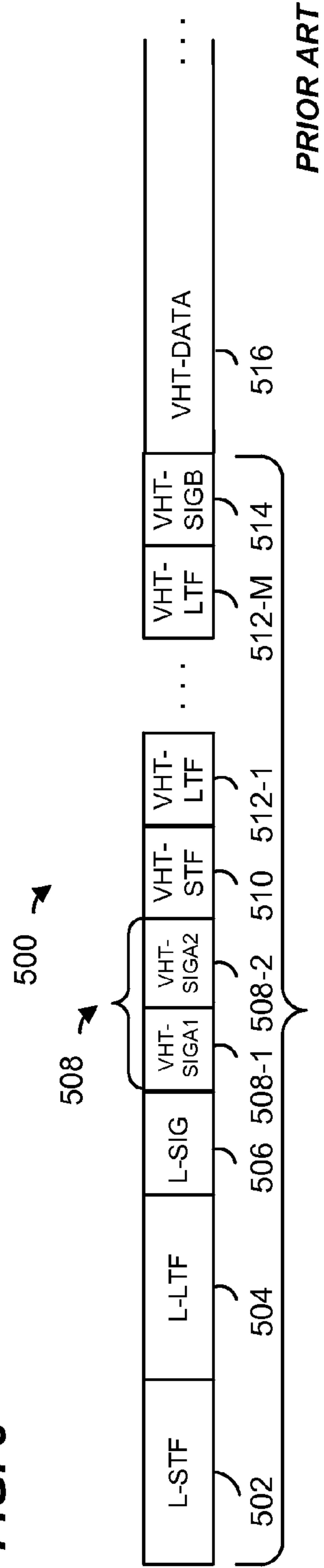


FIG. 6A

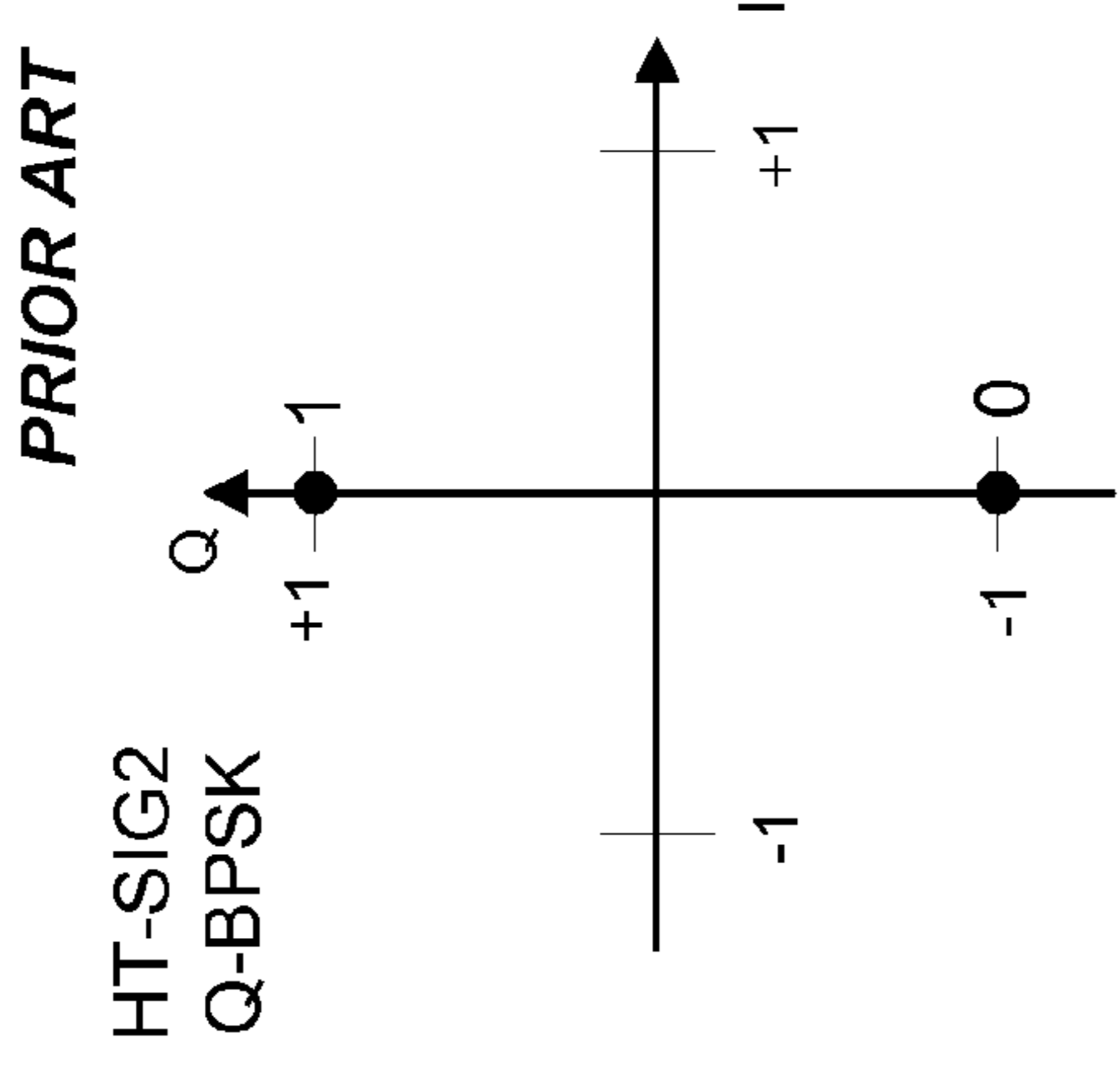
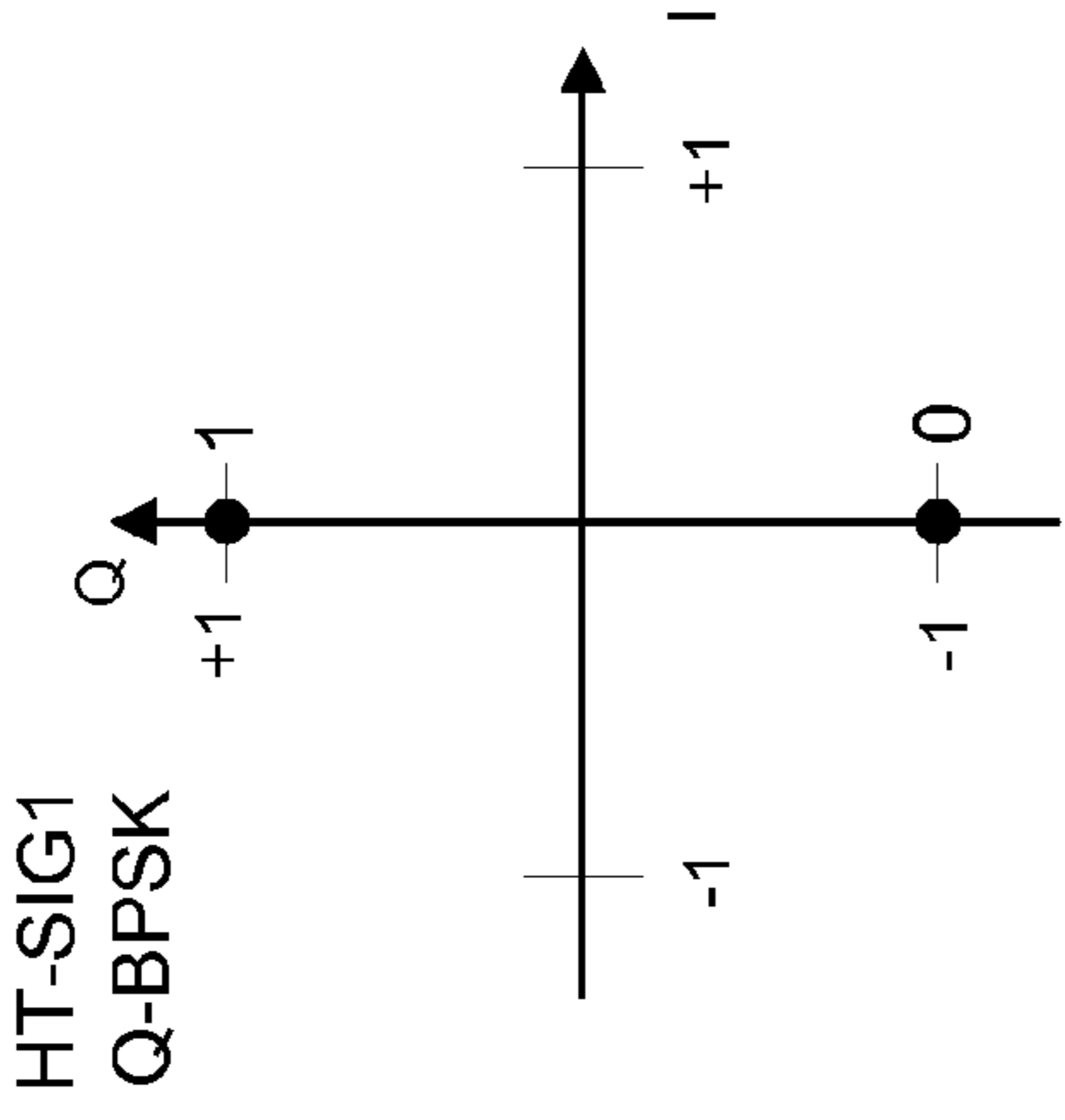
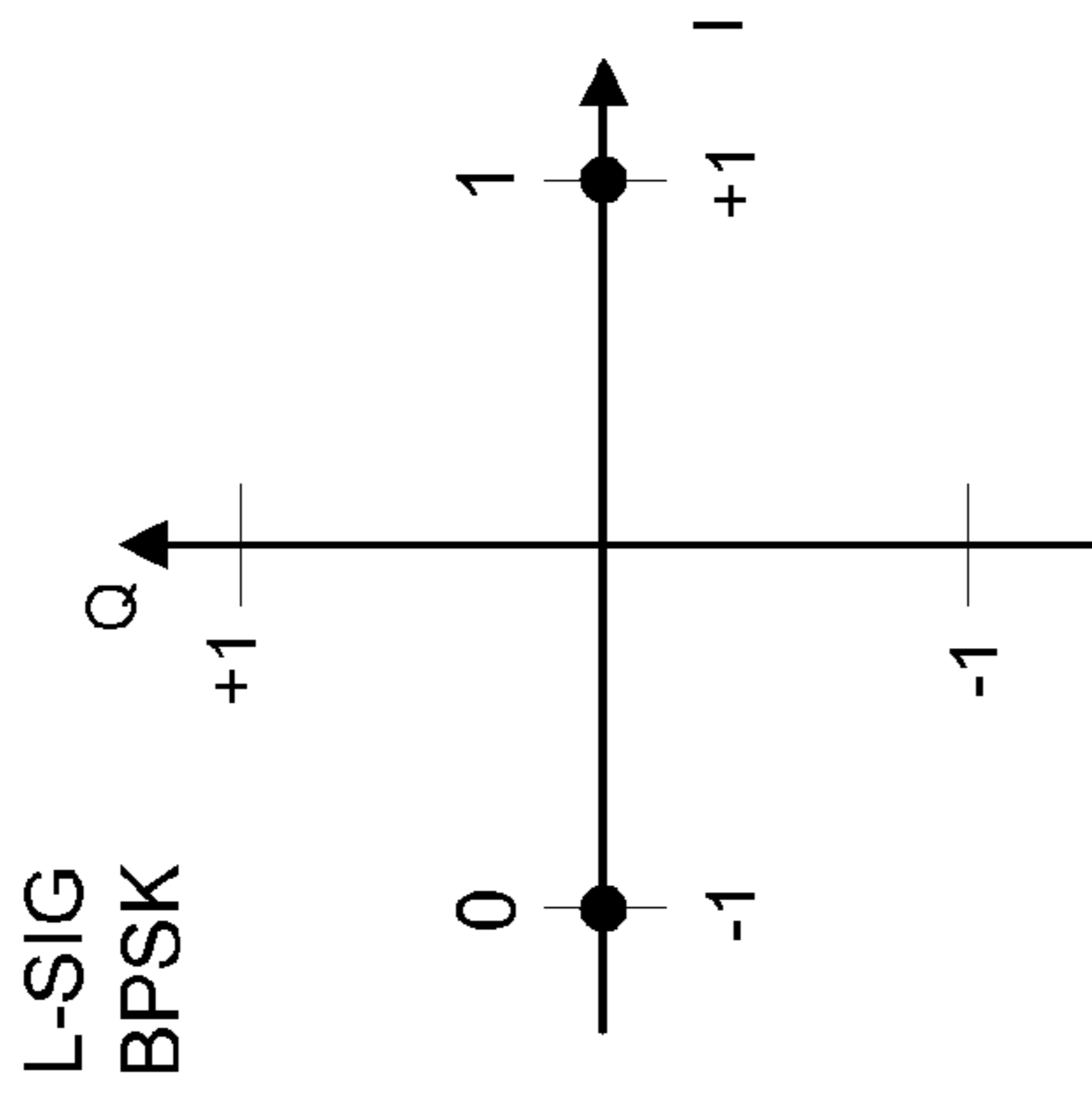


FIG. 6B

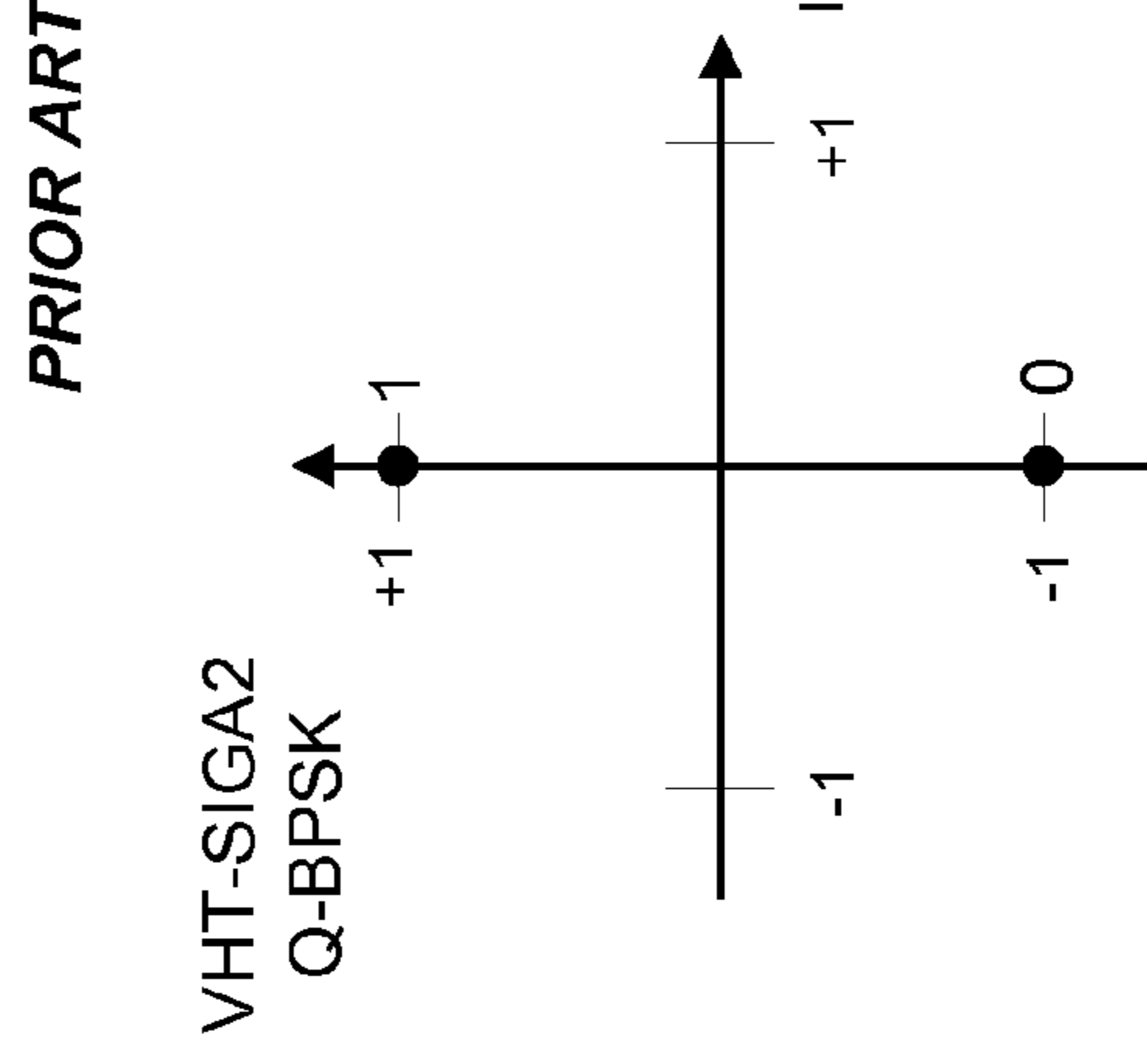
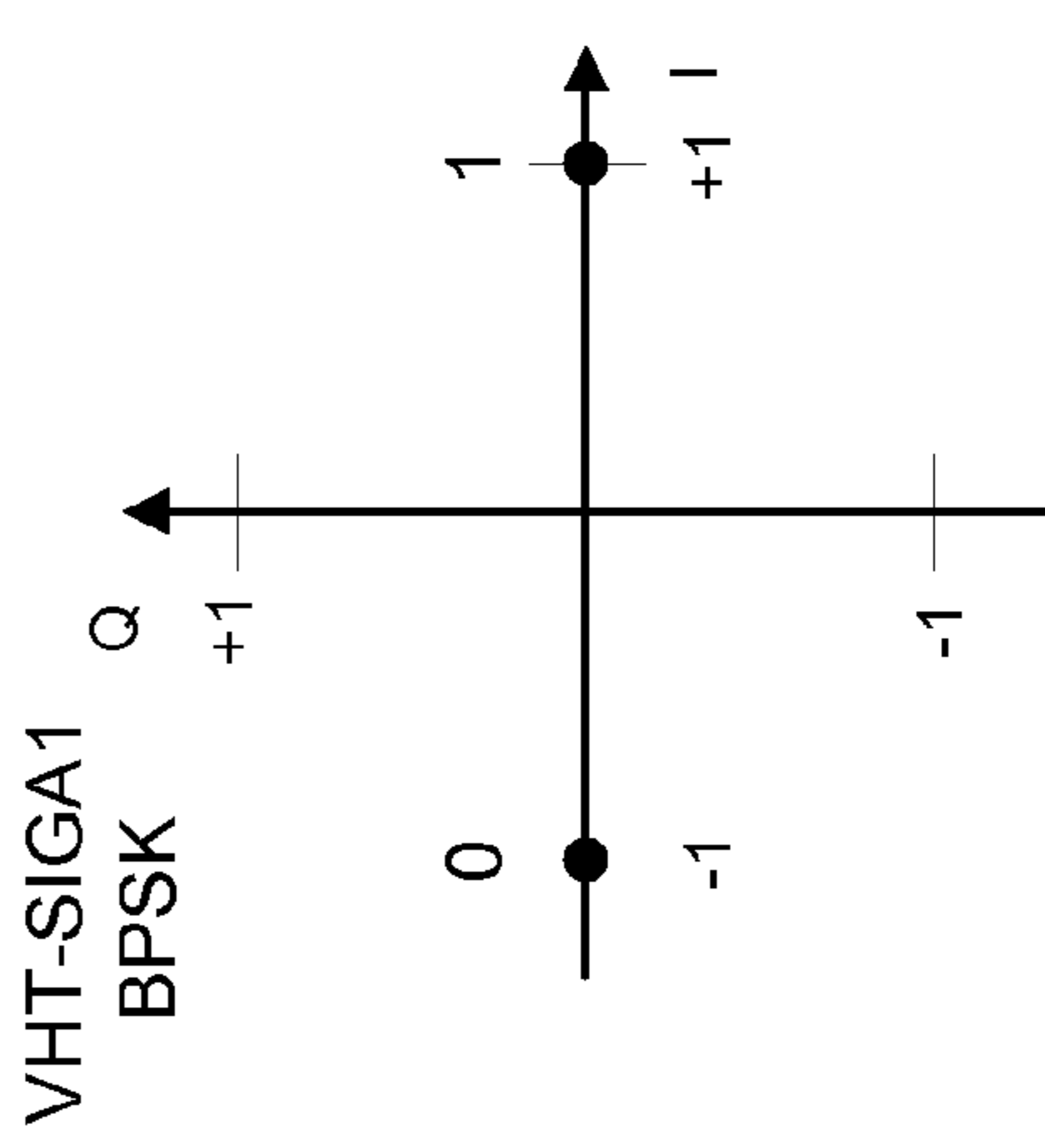
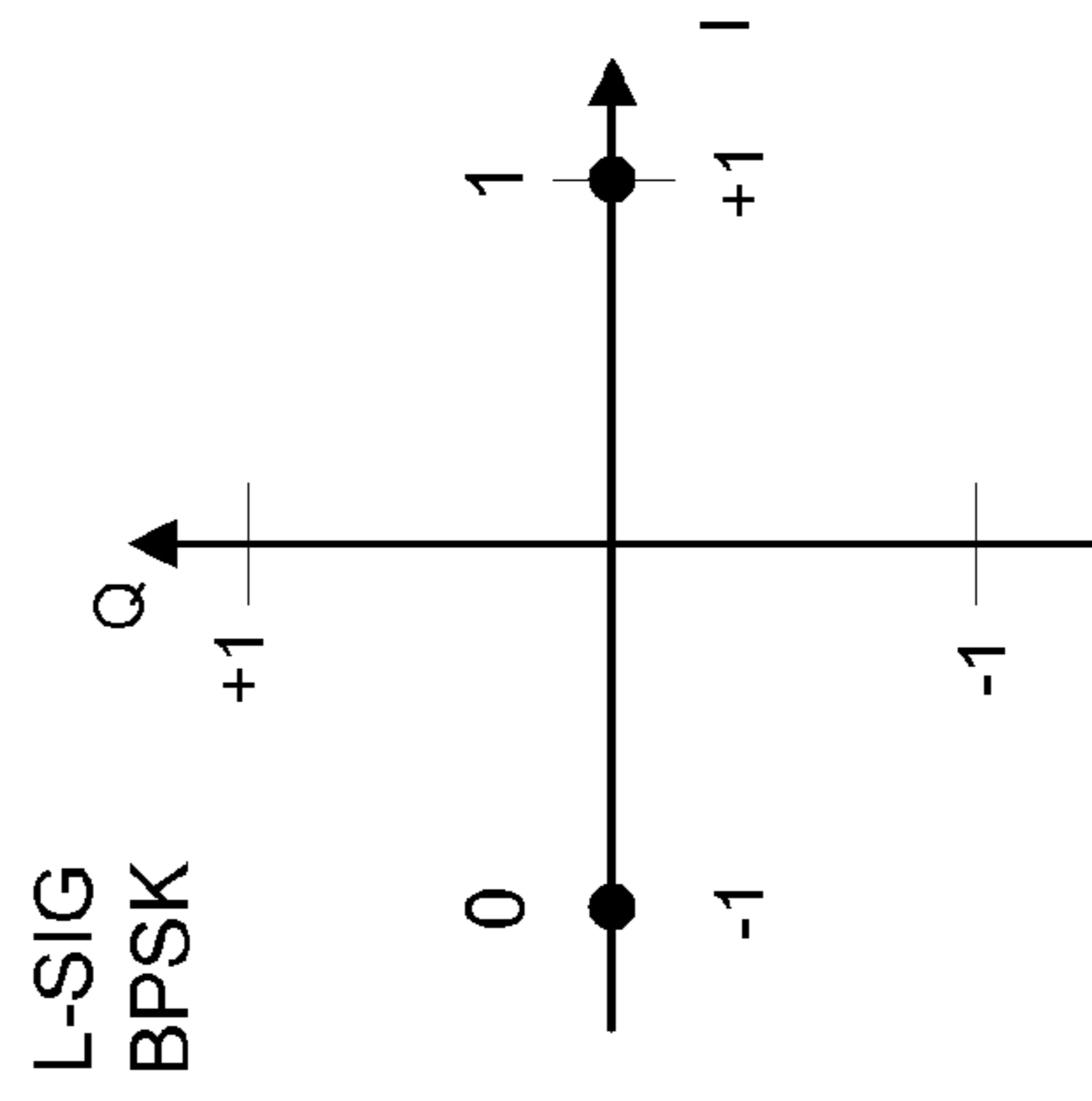


FIG. 7A

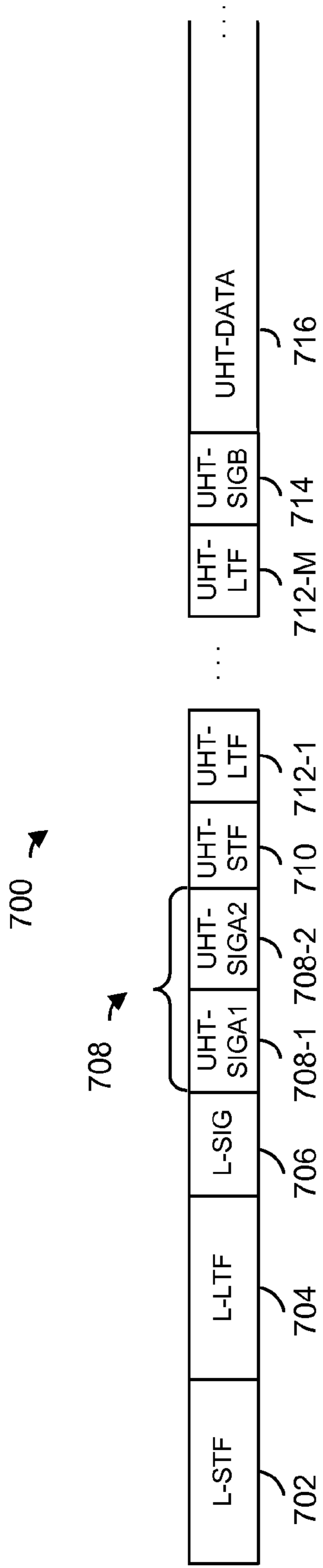


FIG. 7B

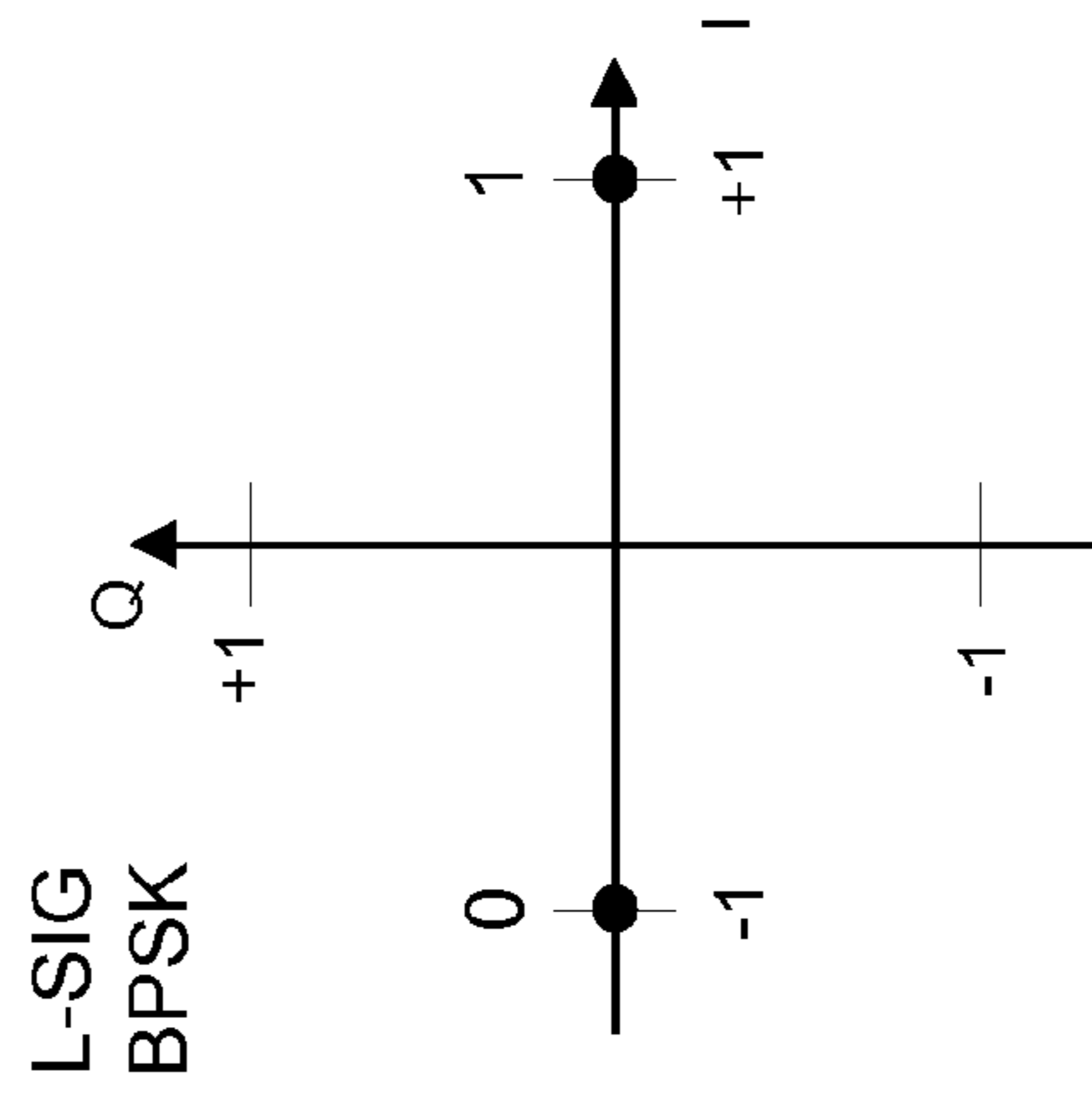


FIG. 7C

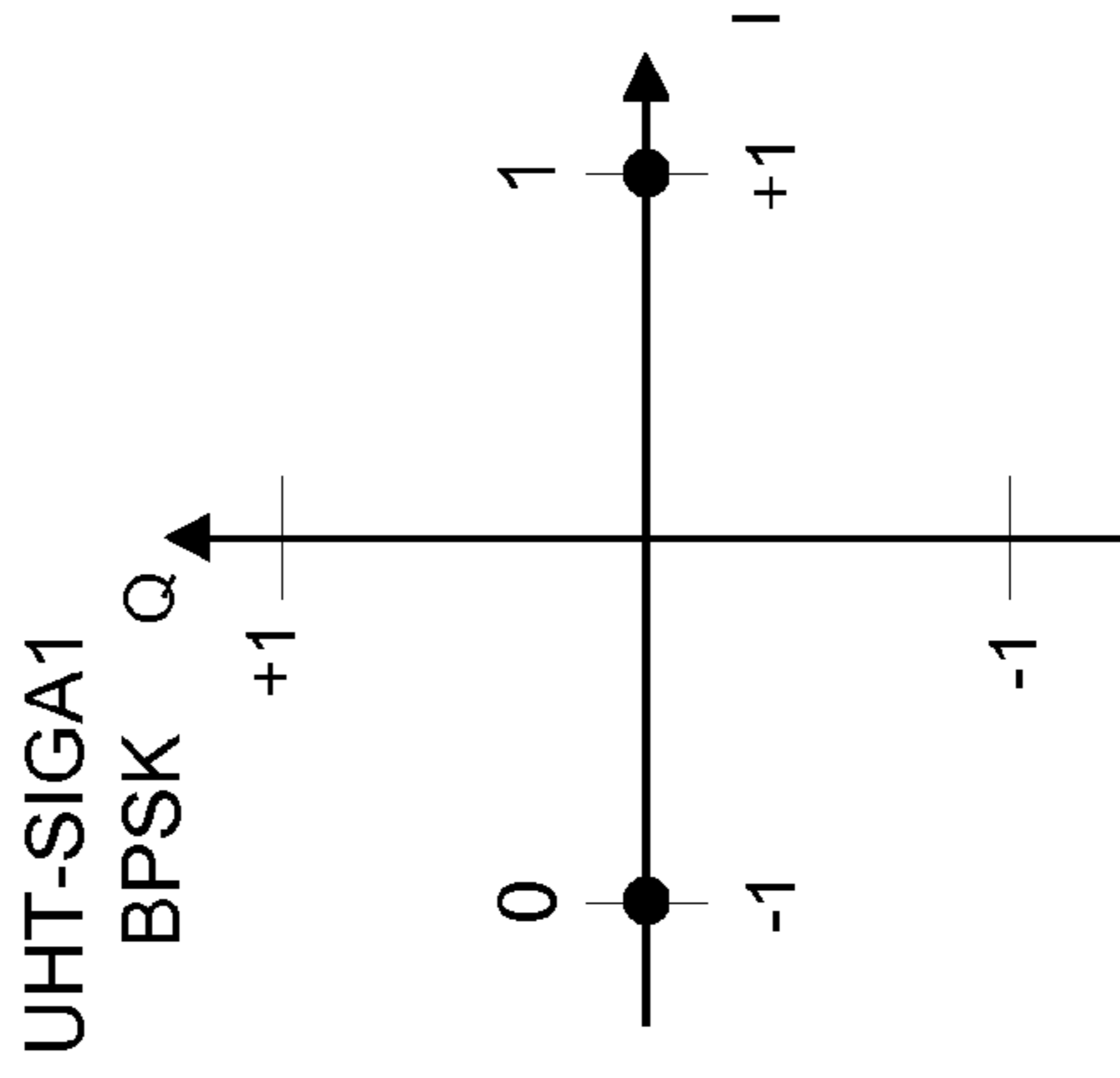


FIG. 7D

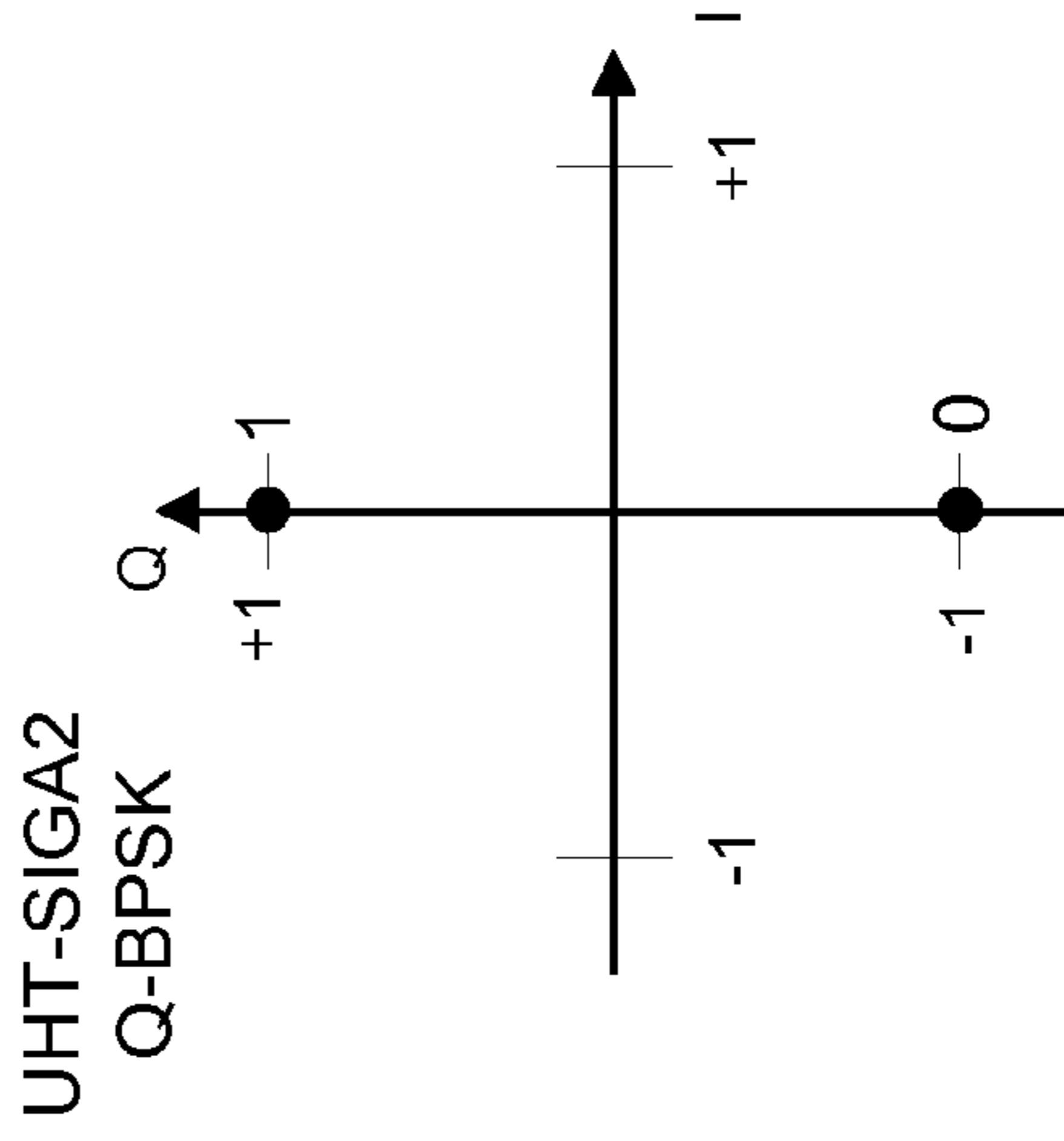


FIG. 8A

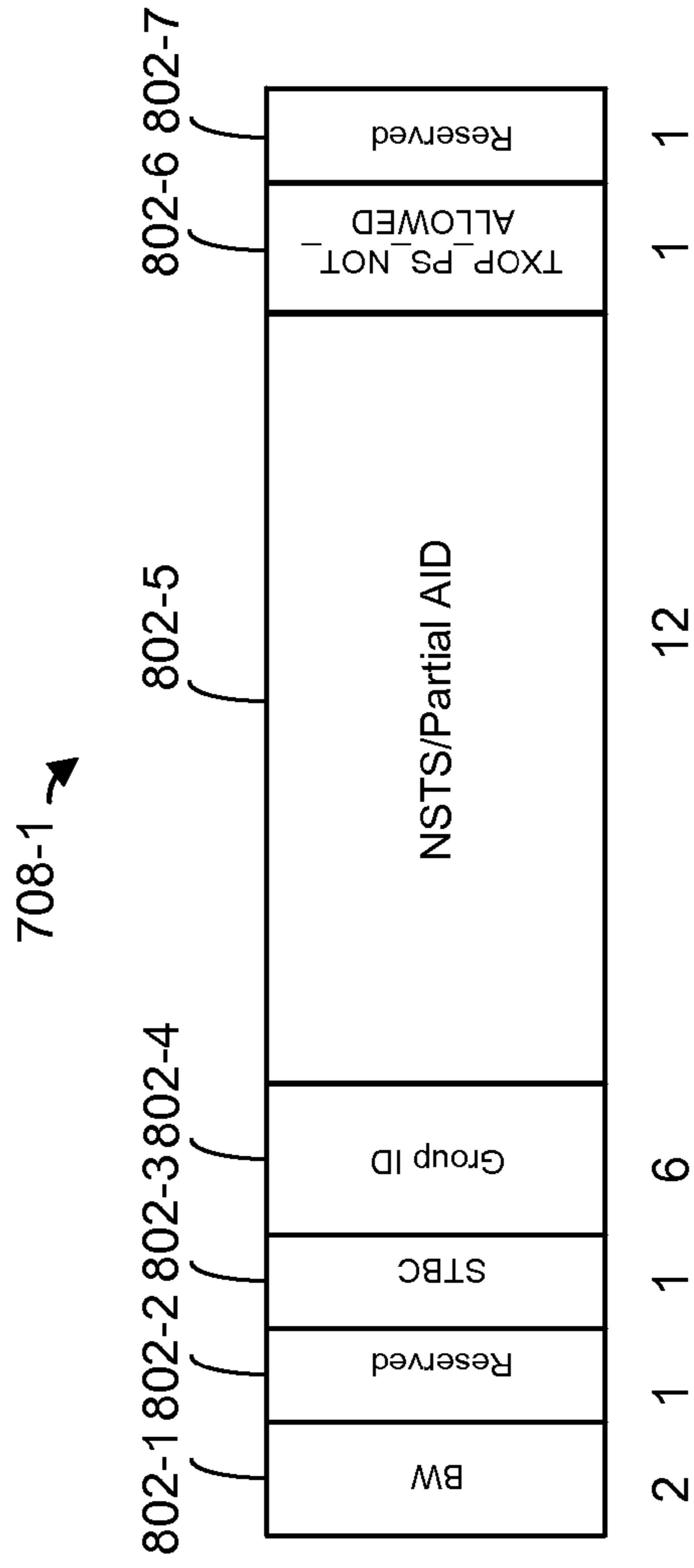


FIG. 8B

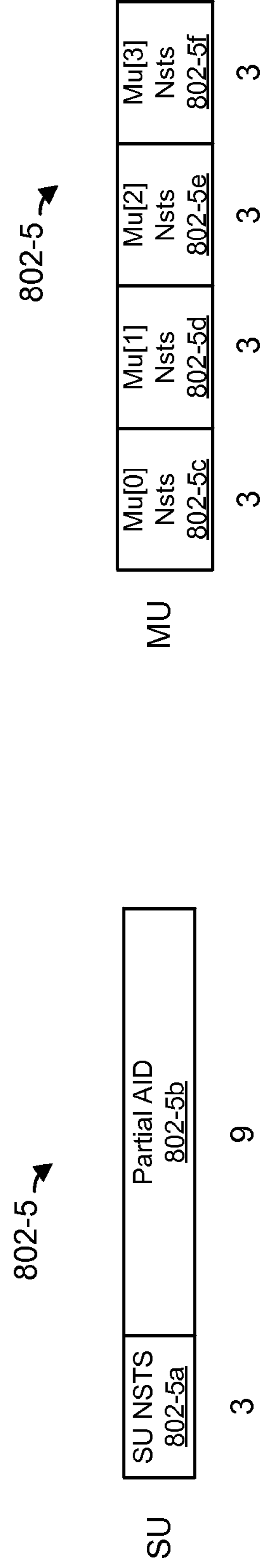


FIG. 8D

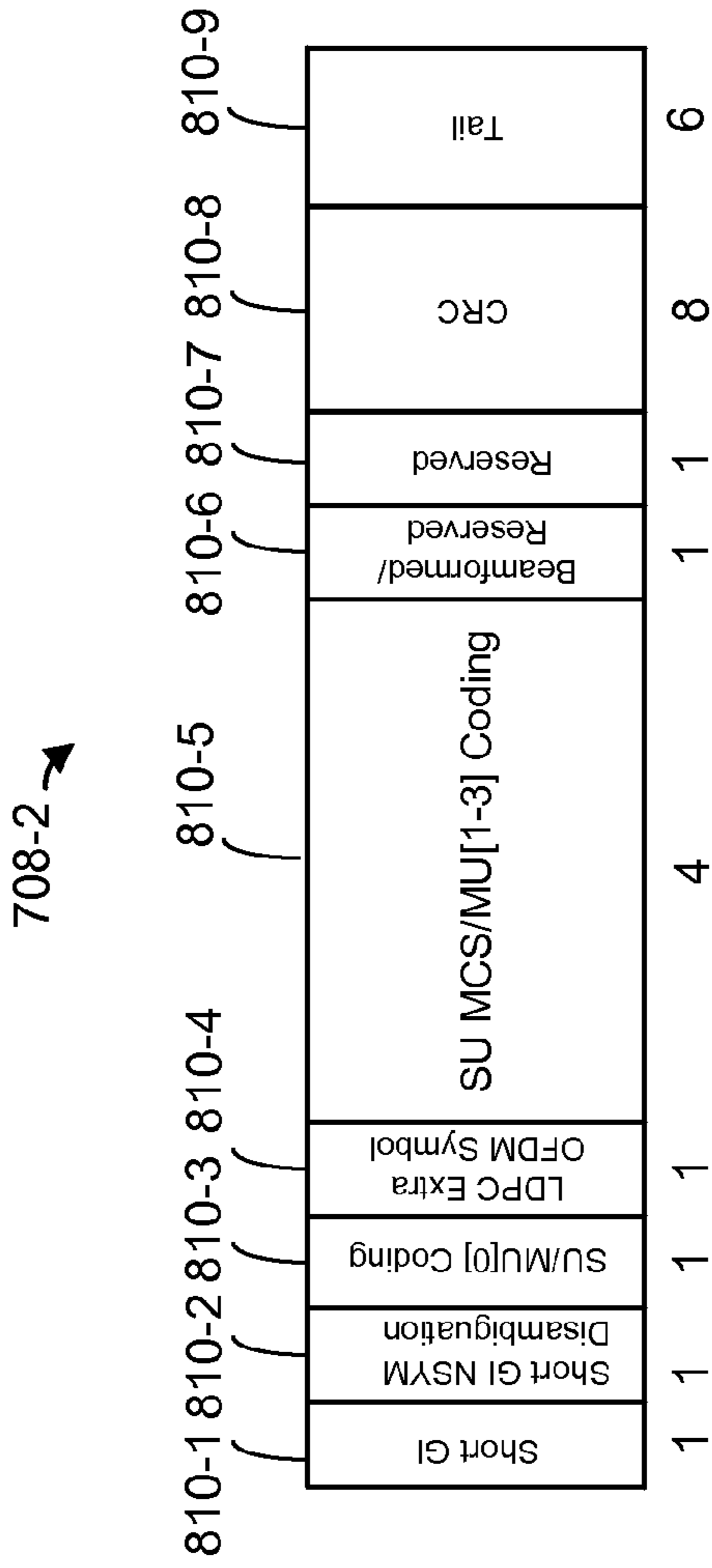


FIG. 8E

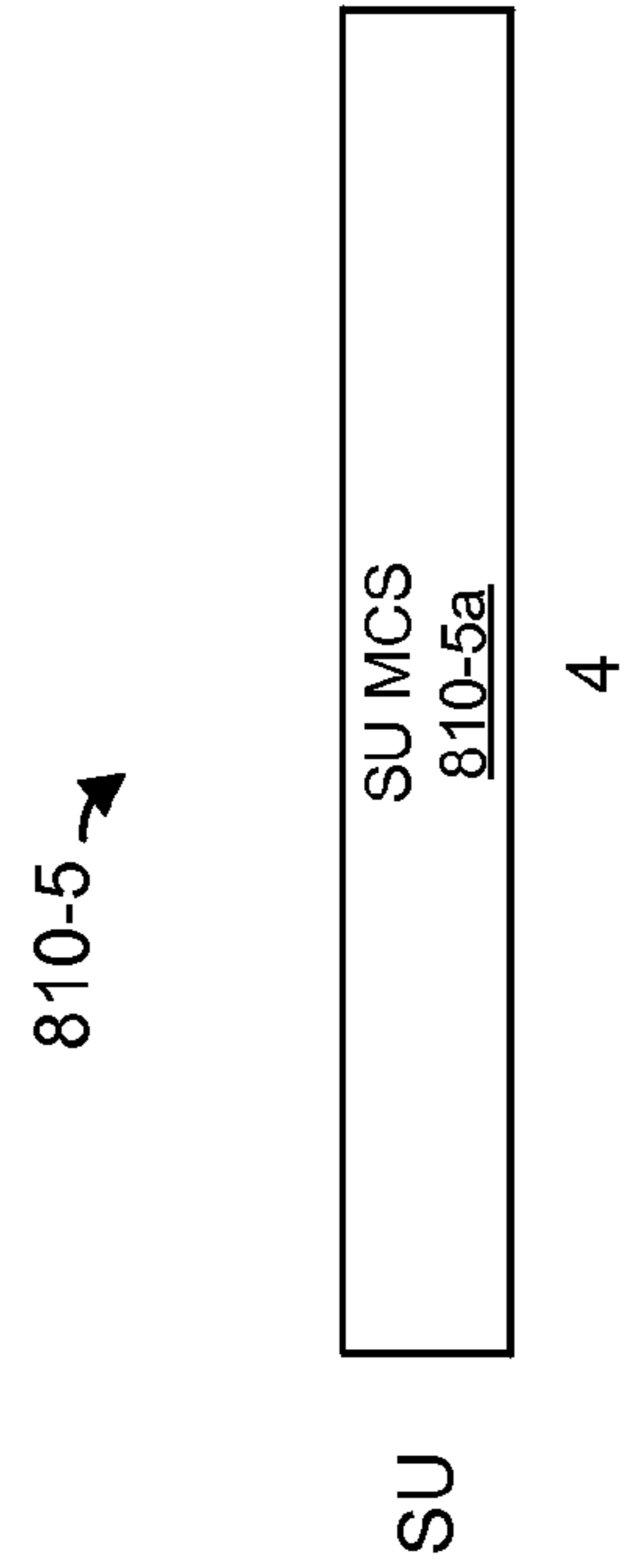


FIG. 8F

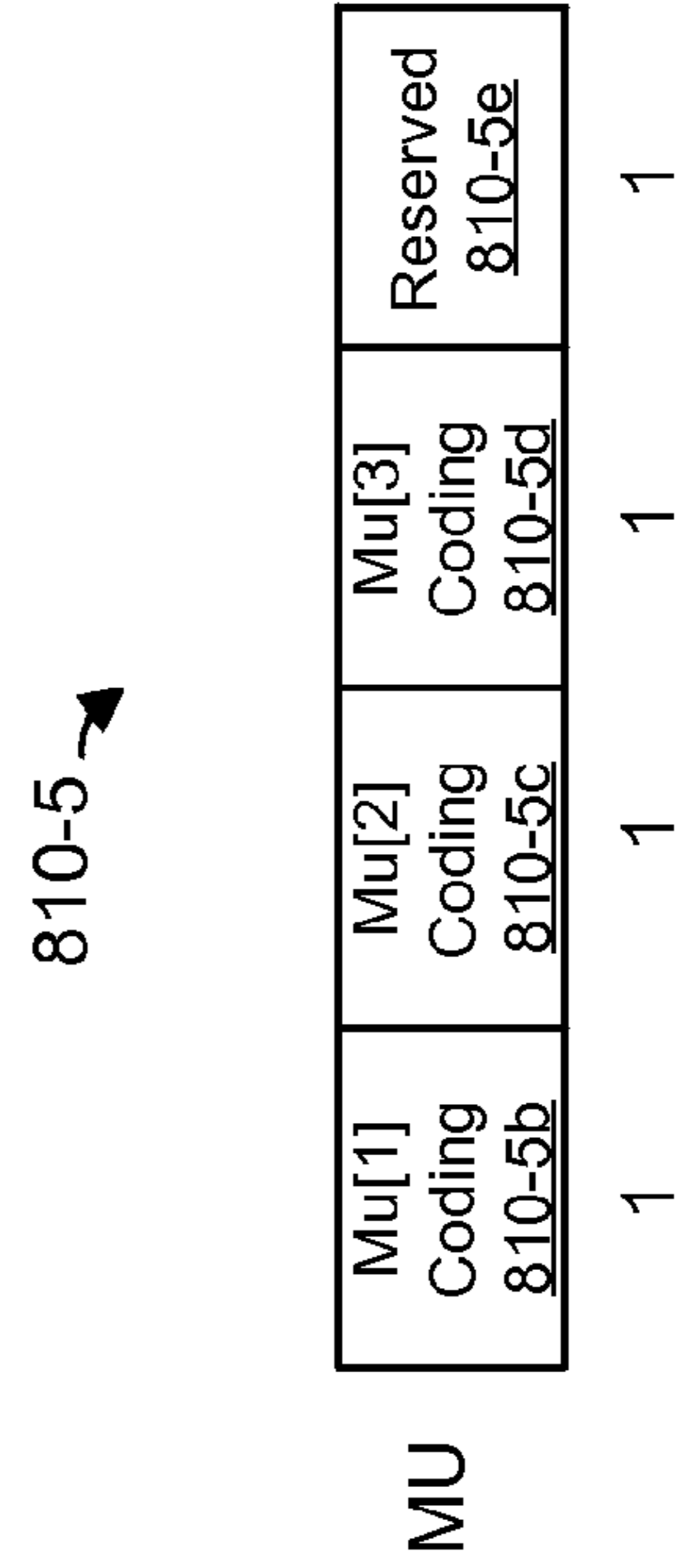


FIG. 9A

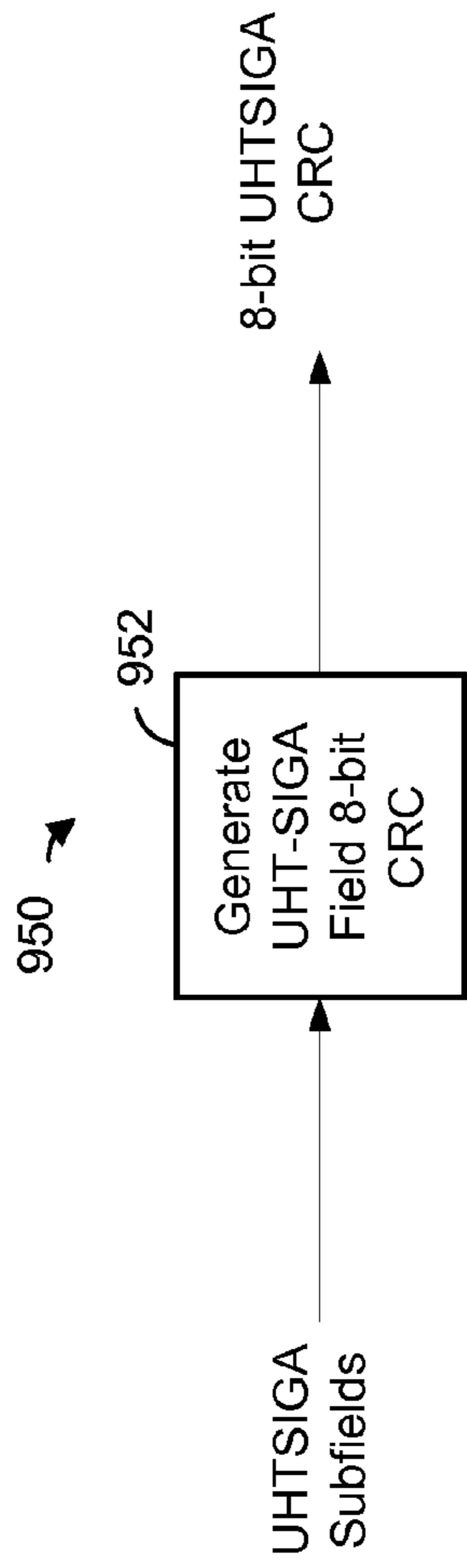


FIG. 9B

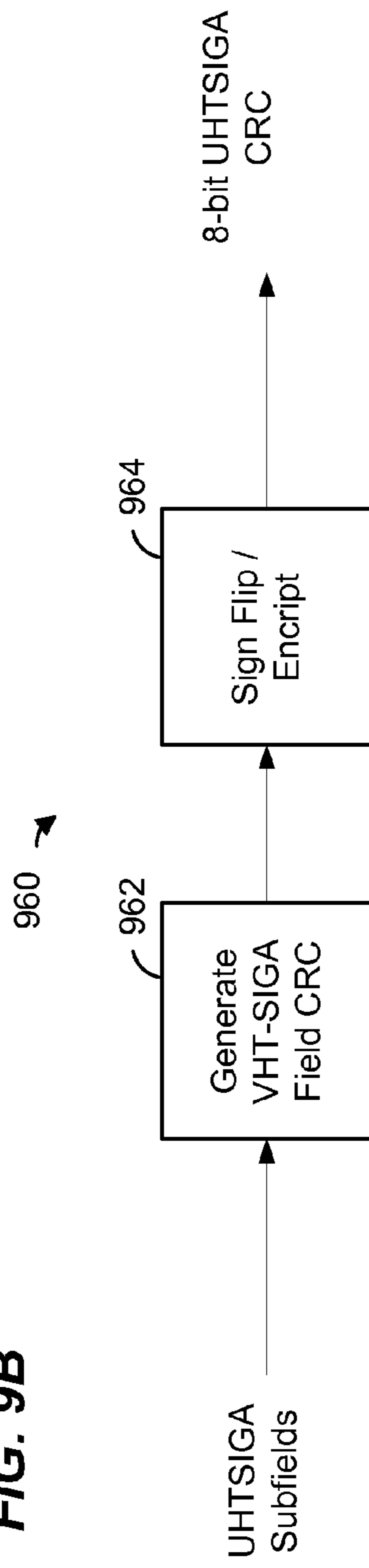


FIG. 9C

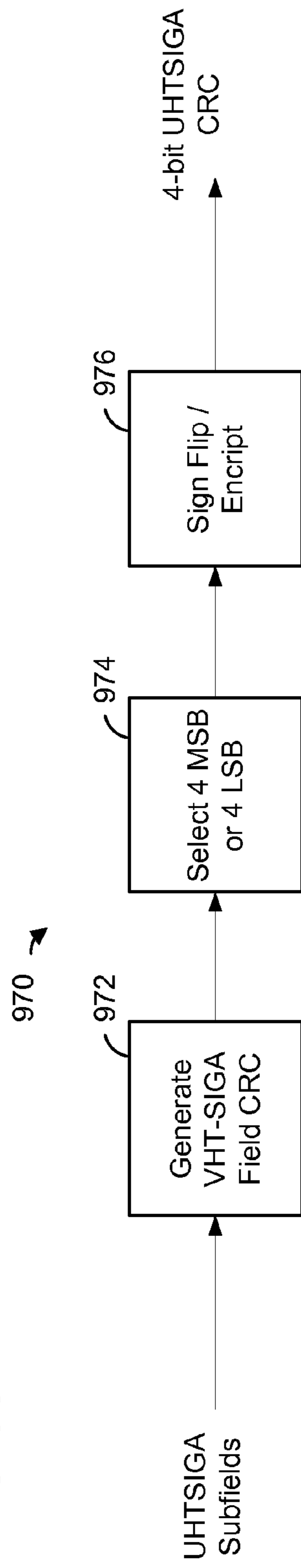


FIG. 10

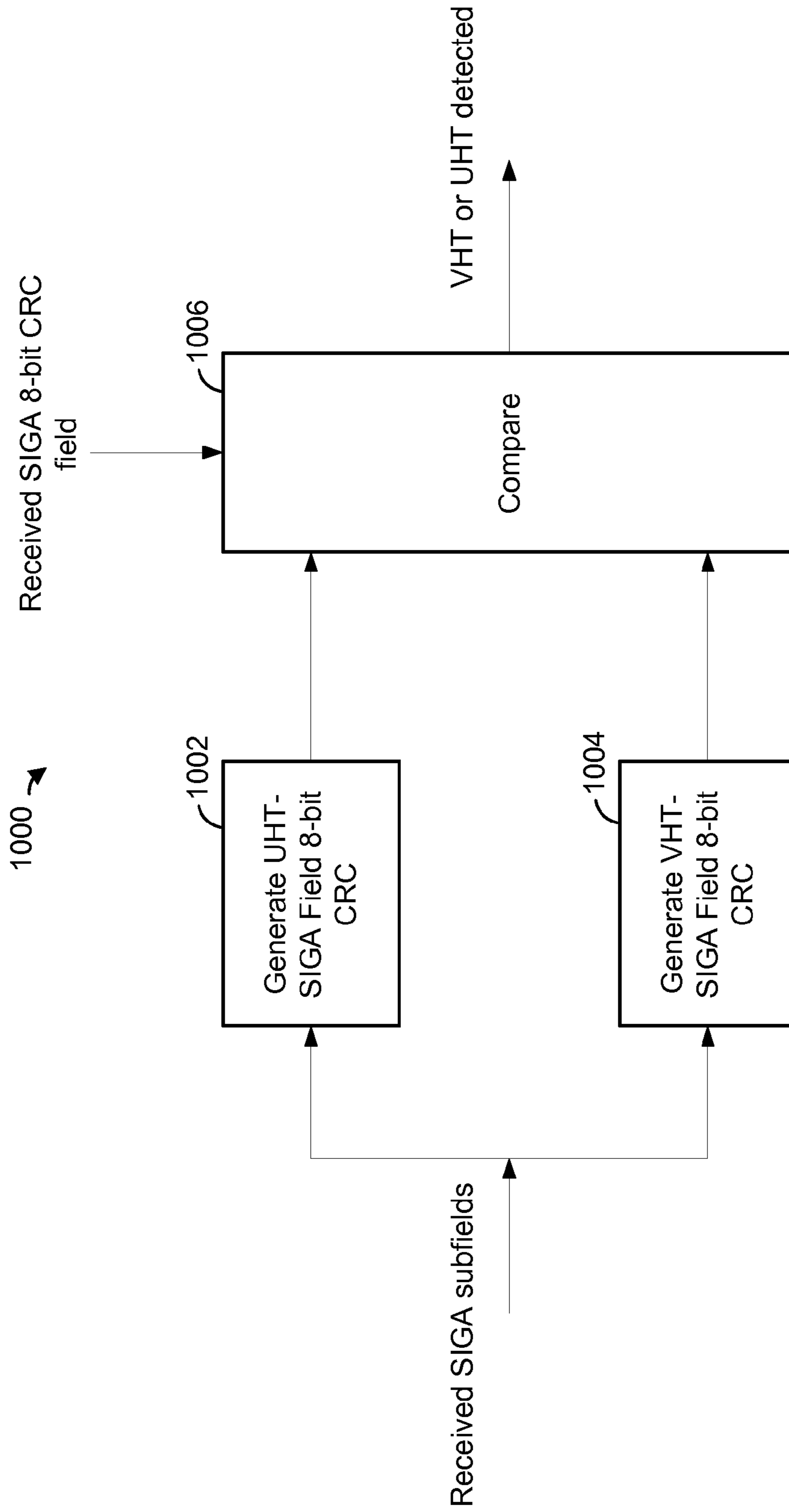


FIG. 11

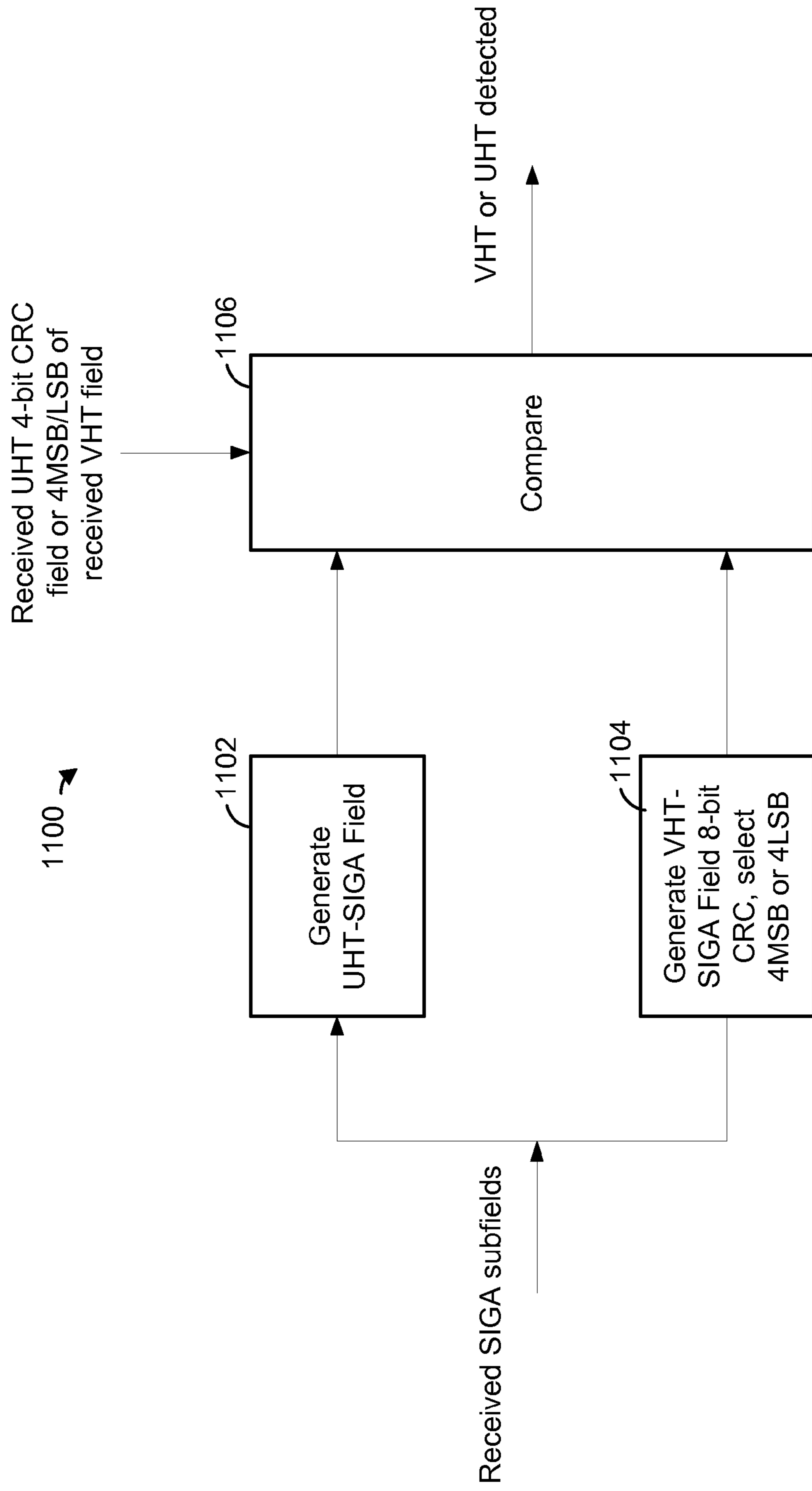


FIG. 12

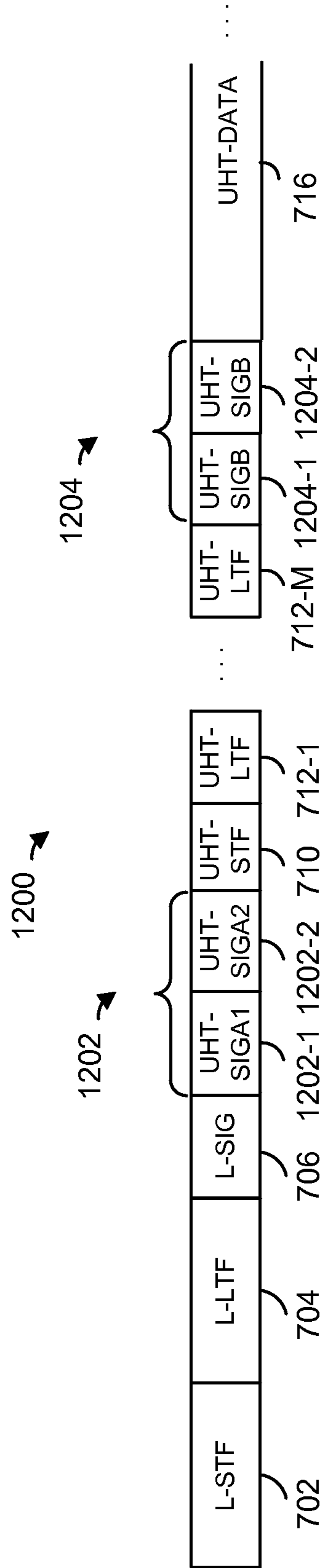


FIG. 13A

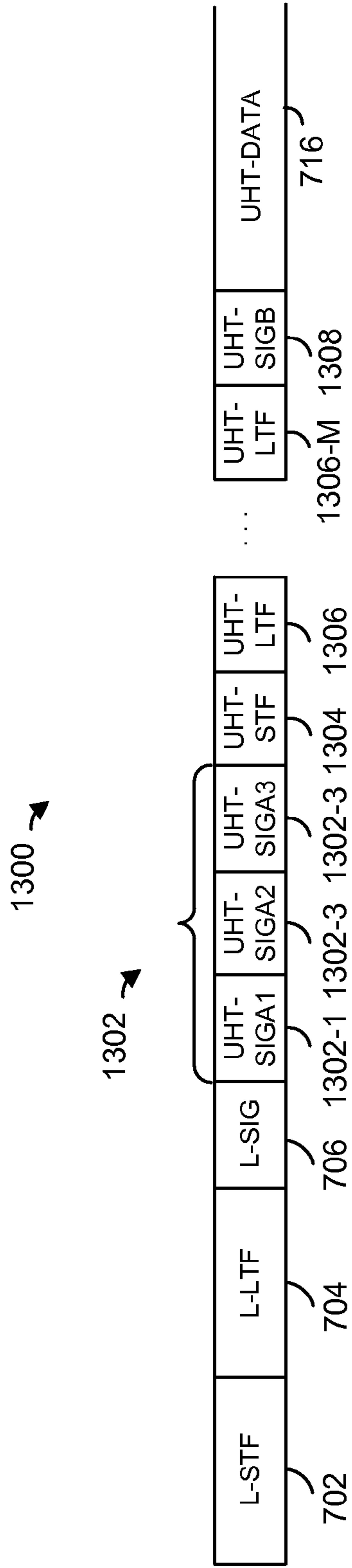


FIG. 13B

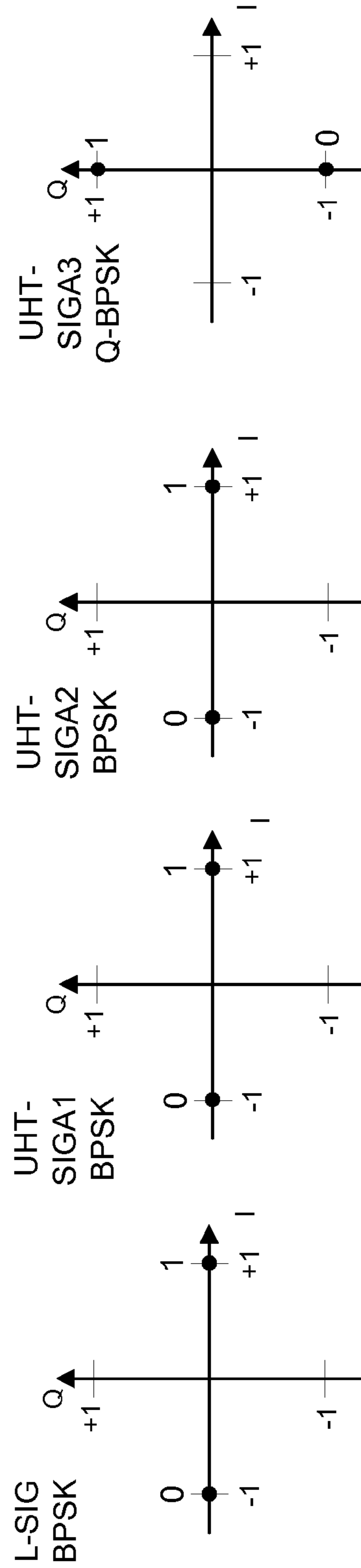


FIG. 14A

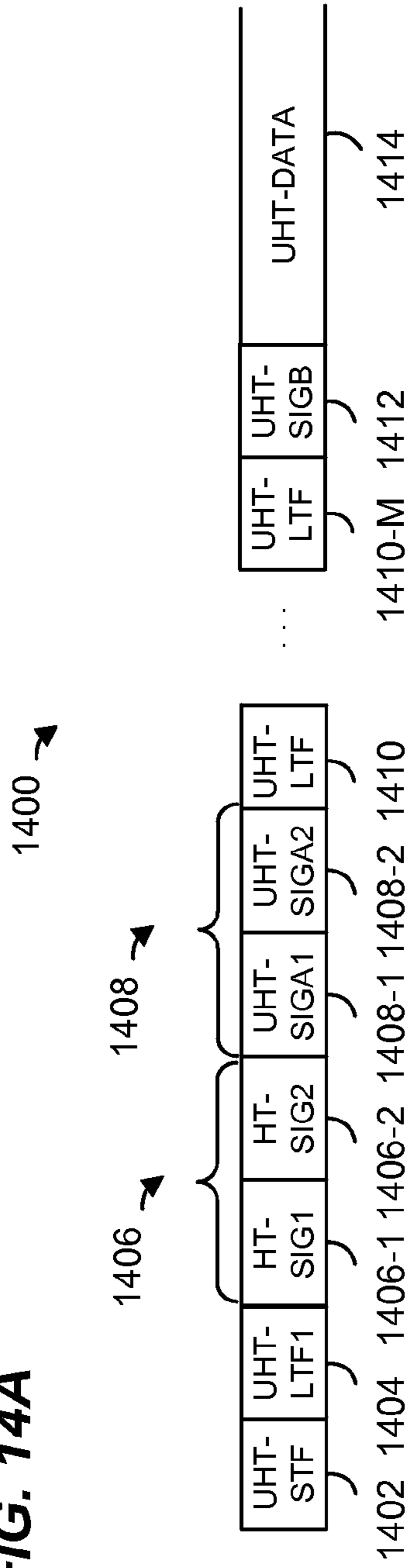


FIG. 14B

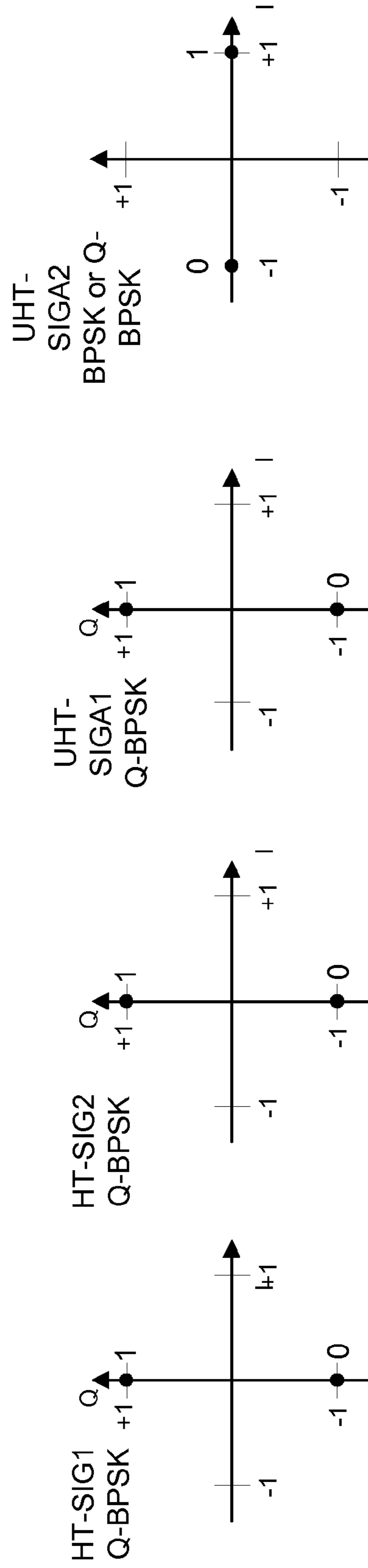


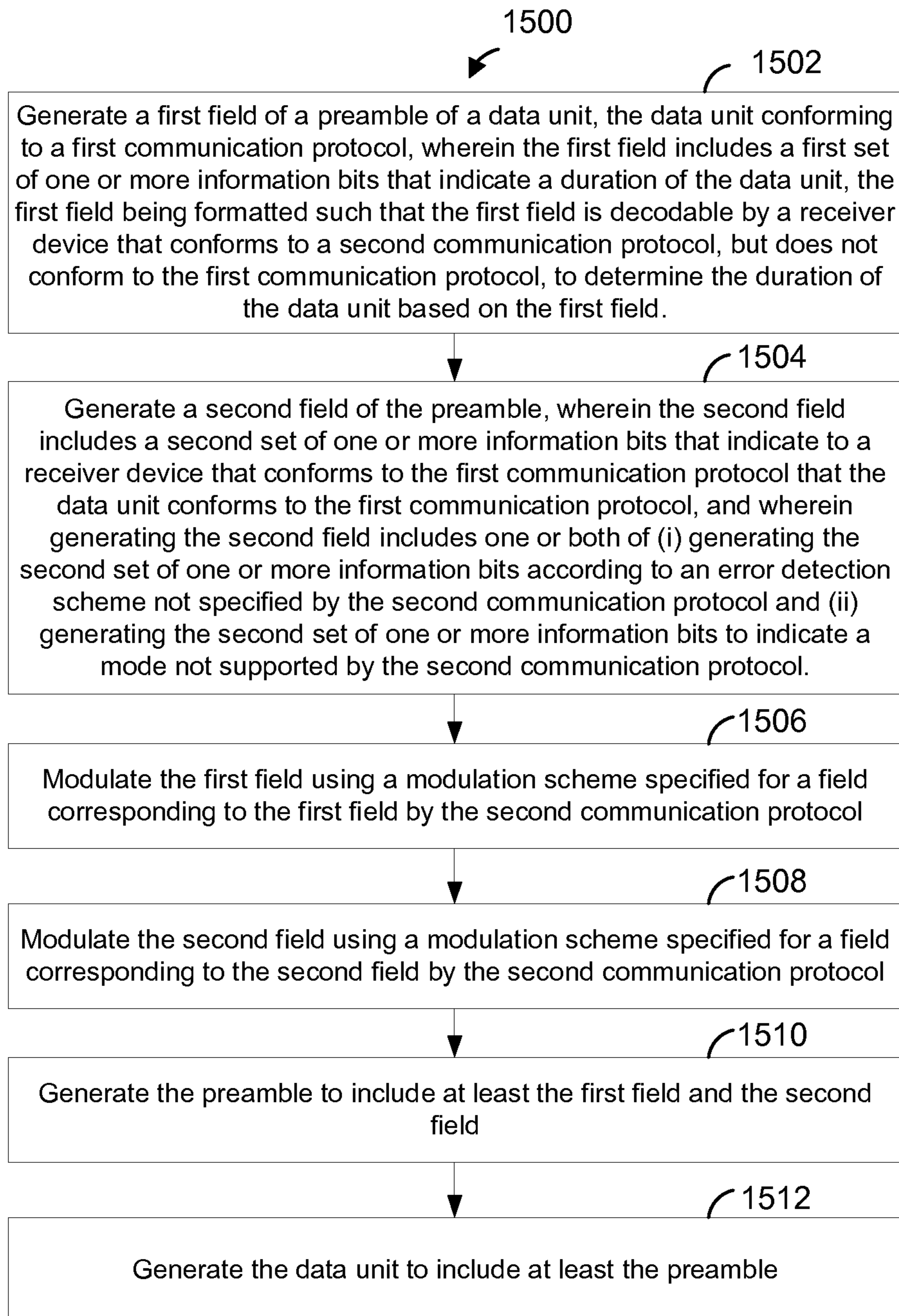
FIG. 15

FIG. 16

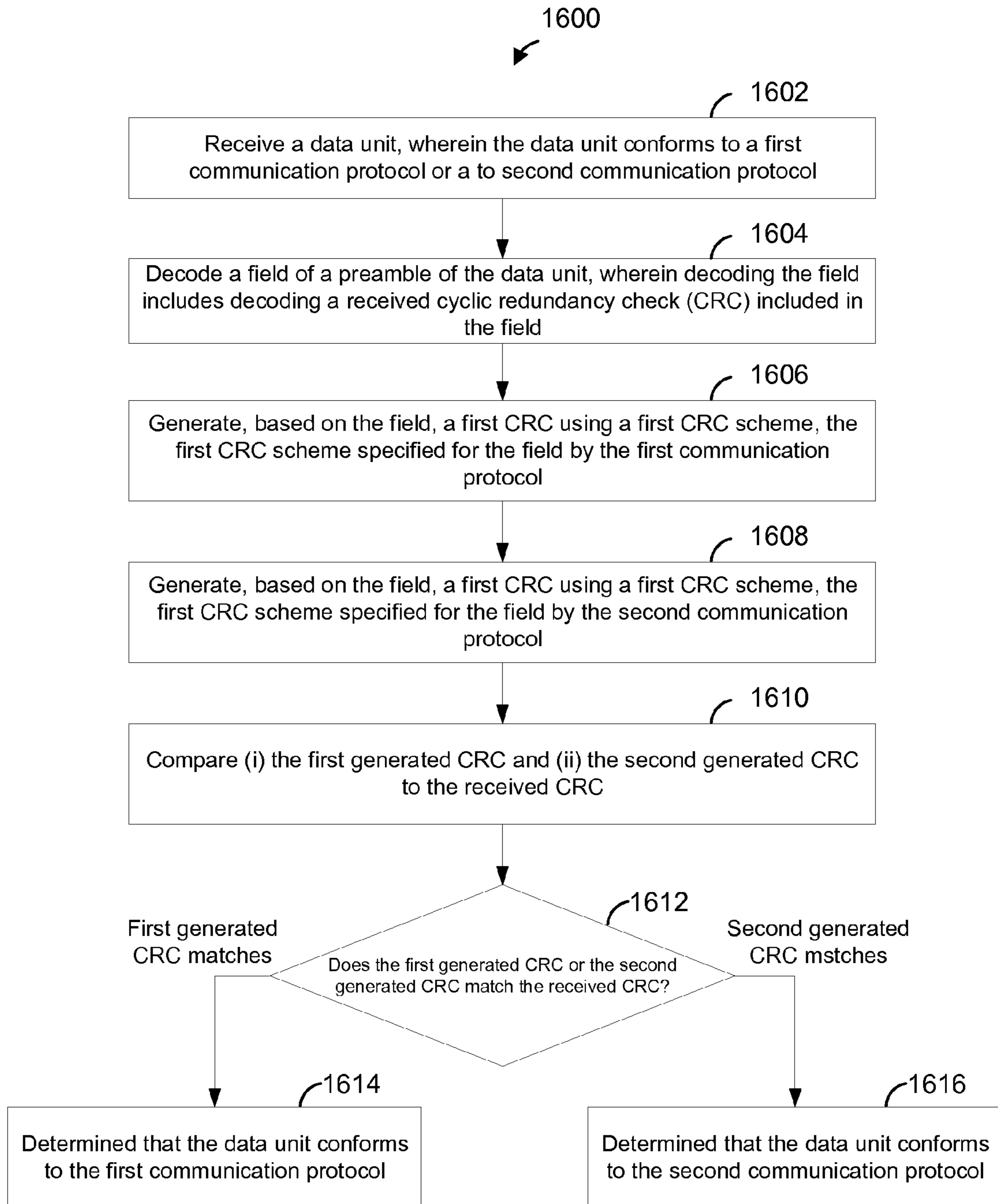
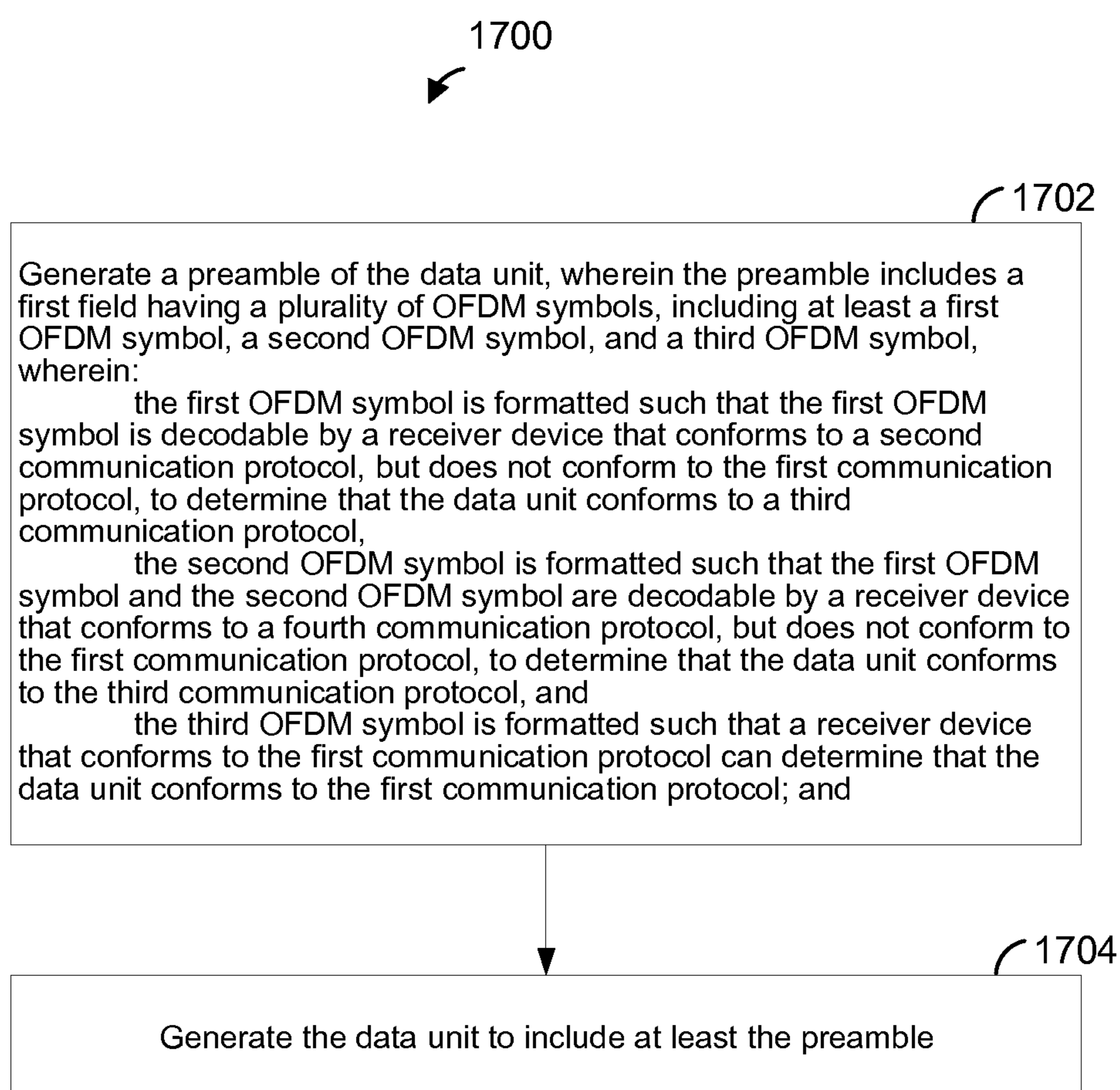


FIG. 17

1**PHYSICAL LAYER FRAME FORMAT FOR
WLAN****CROSS-REFERENCES TO RELATED
APPLICATIONS**

This claims the benefit of U.S. Provisional Patent Application No. 61/619,640, filed Apr. 3, 2012, entitled "Preamble Design for "post-11ac" WLAN at 5 GHz," the disclosure of which is hereby expressly incorporated herein by reference in its entirety.

FIELD OF THE DISCLOSURE

The present disclosure relates generally to communication networks and, more particularly, to wireless local area networks that utilize orthogonal frequency division multiplexing (OFDM).

BACKGROUND

When operating in an infrastructure mode, wireless local area networks (WLANs) typically include an access point (AP) and one or more client stations. WLANs have evolved rapidly over the past decade. Development of WLAN standards such as the Institute for Electrical and Electronics Engineers (IEEE) 802.11a, 802.11b, 802.11g, and 802.11n Standards has improved single-user peak data throughput. For example, the IEEE 802.11b Standard specifies a single-user peak throughput of 11 megabits per second (Mbps), the IEEE 802.11a and 802.11g Standards specify a single-user peak throughput of 54 Mbps, the IEEE 802.11n Standard specifies a single-user peak throughput of 600 Mbps, and the IEEE 802.11ac Standard specifies a single-user peak throughput in the gigabits per second (Gbps) range. Future standards promise to provide even greater throughputs, such as throughputs in the tens of Gbps range.

SUMMARY

In an embodiment, a method for generating a data unit for transmission via a communication channel, the data unit conforming to a first communication protocol, includes generating a first field to be included in a preamble of the data unit, wherein the first field includes a first set of one or more information bits that indicate a duration of the data unit, the first field being formatted such that the first field is decodable by a receiver device that conforms to a second communication protocol, but does not conform to the first communication protocol, to determine the duration of the data unit based on the first field. The method also includes generating a second field to be included in the preamble, wherein the second field includes a second set of one or more information bits that indicate to a receiver device that conforms to the first communication protocol that the data unit conforms to the first communication protocol, and wherein generating the second field includes one or both of (i) generating the second set of one or more information bits according to an error detection scheme not specified by the second communication protocol and (ii) generating the second set of one or more information bits to indicate a mode not supported by the second communication protocol. The method further includes modulating the first field using a modulation scheme specified for a field corresponding to the first field by the second communication protocol, and modulating the second field using a modulation scheme specified for a field corresponding to the second field by the second communication protocol. The method addition-

2

ally includes generating the preamble to include at least the first field and the second field, and generating the data unit to include at least the preamble.

In other embodiments, the method includes any combination of one or more of the following elements.

Generating the second set of one or more information bits according to the error detection scheme not specified by the second communication protocol comprises generating a cyclic redundancy check (CRC) for the second field according to a CRC polynomial different than a CRC polynomial specified for the corresponding field by the second communication protocol.

Generating the second set of one or more information bits according to the error detection scheme not specified by the second communication protocol comprises generating a cyclic redundancy check (CRC) for the second field, including generating a plurality of CRC bits according to a CRC polynomial specified for the corresponding field by the second communication protocol, and encrypting one or more bits of the plurality of CRC bits to generate the CRC for the second field.

Generating the second set of one or more information bits according to the error detection scheme not specified by the second communication protocol comprises generating a cyclic redundancy check (CRC) for the second field, including generating a plurality of CRC bits according to a CRC polynomial specified for the corresponding field by the second communication protocol, selecting a subset of the plurality of CRC bits, the subset to be utilized for the CRC for the second field; and encrypting one or more bits in the selected subset of the plurality of CRC bits to generate the CRC for the second field.

The second field includes a modulation and coding (MCS) subfield, and wherein generating the second set of one or more information bits to indicate the mode not supported by the second communication protocol includes generating the MCS subfield to indicate a modulation and coding scheme not supported by the second communication protocol.

The second field further includes an indication that the data unit conforms to the first communication protocol.

The second communication protocol conforms to the Institute for Electrical and Electronics Engineers (IEEE) 802.11ac Standard.

The first communication protocol is a communication protocol that supports a higher throughput than the IEEE 802.11ac Standard.

In another embodiment, an apparatus comprises a network interface configured to generate a first field to be included in a preamble of the data unit, wherein the first field includes a first set of one or more information bits that indicate a duration of the data unit, the first field being formatted such that the first field is decodable by a receiver device that conforms to a second communication protocol, but does not conform to the first communication protocol, to determine the duration of the data unit based on the first field. The network interface is also configured to generate a second field to be included in the preamble, wherein the second field includes a second set of one or more information bits that indicate to a receiver device that conforms to the first communication protocol that the data unit conforms to the first communication protocol, and wherein generating the second field includes one or both of (i) generating the second set of one or more information bits according to an error detection scheme not specified by the second communication protocol and (ii) generating the second set of one or more information bits to indicate a mode not supported by the second communication protocol. The network interface is further configured to modulate the first field

using a modulation scheme specified for a field corresponding to the first field by the second communication protocol, and modulate the second field using a modulation scheme specified for a field corresponding to the second field by the second communication protocol. The network interface is additionally configured to generate the preamble to include at least the first field and the second field, and generate the data unit to include at least the preamble.

In other embodiments, the apparatus includes any combination of one or more of the following features.

The network interface is configured to generate the second set of one or more information bits according to the error detection scheme not specified by the second communication protocol at least by generating a cyclic redundancy check (CRC) for the second field according to a CRC polynomial different than a CRC polynomial specified for the corresponding field by the second communication protocol.

The network interface is configured to generate the second set of one or more information bits according to the error detection scheme not specified by the second communication protocol at least by generating a cyclic redundancy check (CRC) for the second field, including generating a plurality of CRC bits according to a CRC polynomial specified for the corresponding field by the second communication protocol, and encrypting one or more bits of the plurality of CRC bits to generate the CRC for the second field.

The network interface is configured to generate the second set of one or more information bits according to the error detection scheme not specified by the second communication protocol at least by generating a cyclic redundancy check (CRC) for the second field, including generating a plurality of CRC bits according to a CRC polynomial specified for the corresponding field in the second communication protocol, selecting a subset of the plurality of CRC, the subset to be utilized for the CRC for the second field; and encrypting one or more bits in the selected subset of the plurality of CRC bits to generate the CRC for the second field.

The second field includes a modulation and coding (MCS) subfield.

The network interface is configured to generate the second set of one or more information bits to indicate the mode not supported by the second communication protocol at least by generating the MCS subfield to indicate a modulation and coding scheme not supported by the second communication protocol.

The network interface is further configured to include, in the second field, an indication that the data unit conforms to the first communication protocol.

The second communication protocol conforms to the Institute for Electrical and Electronics Engineers (IEEE) 802.11ac Standard.

The first communication protocol is a communication protocol that supports a higher throughput than the IEEE 802.11ac Standard.

In yet another embodiment, a method includes receiving a data unit, wherein the data unit conforms to a first communication protocol or to a second communication protocol, and decoding a field of a preamble of the data unit, including decoding a received cyclic redundancy check (CRC) included in the field. The method also includes generating, based on the field, a first CRC using a first CRC generation scheme, the first CRC generation scheme specified for the first field by the first communication protocol. The method further includes generating, based on the field, a second CRC using a second CRC generation scheme, the second CRC generation scheme specified for the field by the second communication protocol. The method further still includes comparing (i) the first gen-

erated CRC and (ii) the second generated CRC to the received CRC. The method additionally includes determining that the data unit conforms to the first communication protocol when the first generated CRC matches the received CRC, and determining that the data unit conforms to the second communication protocol when the second generated CRC matches the received CRC.

In other embodiments, the method includes any combination of one or more of the following elements.

Generating the first CRC comprises generating the first CRC according to a first CRC polynomial, the first CRC polynomial specified for the field by the first communication protocol.

Generating the second CRC comprises generating the second CRC according to a second CRC polynomial, the second CRC polynomial specified for the field by the second communication protocol, wherein the second CRC polynomial is different than the first CRC polynomial.

Generating the first CRC comprises generating the first CRC according to a first CRC polynomial, the first CRC polynomial specified for the field by the first communication protocol.

Generating the second CRC comprises generating a plurality of CRC bits according to the first CRC polynomial, and encrypting one or more bits of the plurality of CRC bits to generate the second CRC.

Generating the second CRC comprises generating a plurality of CRC bits according to the first CRC polynomial, selecting a subset of the plurality of CRC bits, the subset to be utilized for the CRC for the second CRC; and encrypting one or more bits in the selected subset of the plurality of CRC bits to generate the second CRC.

In still another embodiment, an apparatus comprises a network interface configured to receive a data unit, wherein the data unit conforms to a first communication protocol or a second communication protocol, and decode a field of a preamble of the data unit, including decoding a received cyclic redundancy check (CRC) included in the field. The network interface is also configured to generate, based on the field, a first CRC using a first CRC generation scheme, the first CRC generation scheme specified for the first field by the first communication protocol, and generate, based on the field, a second CRC using a second CRC generation scheme, the second CRC generation scheme specified for the field by the second communication protocol. The network interface is further configured to compare the first generated CRC and the second generated CRC to the received CRC. The network interface is additionally configured to determine that the data unit conforms to the first communication protocol when the first generated CRC matches the received CRC, and determine that the data unit conforms to the second communication protocol when the second generated CRC matches the received CRC.

In other embodiments, the apparatus includes any combination of one or more of the following features.

The network interface is configured to generate the first CRC the first CRC according to a first CRC polynomial, the first CRC polynomial specified for the field by the first communication protocol.

Generate the second CRC according to a second CRC polynomial, the second CRC polynomial specified for the field by the second communication protocol, wherein the second CRC polynomial is different than the first CRC polynomial.

Generate the second CRC at least by generating a plurality of CRC bits according to the first CRC polynomial, and encrypting one or more bits of the plurality of CRC bits to generate the second CRC.

The network interface is configured to generate the first CRC according to a first CRC polynomial, the first CRC polynomial specified for the field by the first communication protocol.

Generate the second CRC at least by generating a plurality of CRC bits according to the first CRC polynomial, selecting a subset of the plurality of CRC bits, the subset to be utilized for the CRC for the second CRC; and encrypting one or more bits in the selected subset of the plurality of CRC bits to generate the second CRC.

In still another embodiment, a method for generating a data unit for transmission via a communication channel, the data unit conforming to a first communication protocol, includes generating a preamble of the data unit, wherein the preamble includes a first field having a plurality of orthogonal frequency division multiplexing (OFDM) symbols, including at least (i) a first OFDM symbol, (ii) a second OFDM symbol, and (iii) a third OFDM symbol. The first OFDM symbol is formatted such that the first OFDM symbol is decodable by a receiver device that conforms to a second communication protocol, but does not conform to the first communication protocol, to determine that the data unit conforms to a third communication protocol. The second OFDM symbol is formatted such that the first OFDM symbol and the second OFDM symbol are decodable by a receiver device that conforms to a fourth communication protocol, but does not conform to the first communication protocol, to determine that the data unit conforms to the third communication protocol. The third OFDM symbol is formatted such that a receiver device that conforms to the first communication protocol can determine that the data unit conforms to the first communication protocol. The method also includes generating the data unit to include at least the preamble.

In other embodiments, the method includes any combination of one or more of the following elements.

A second field of the preamble substantially conforms to the third communication protocol, and wherein the second field includes a rate and a length subfield that indicate the duration of the data unit.

The first OFDM symbol is modulated using the same modulation as the second OFDM symbol, wherein the modulation is different than the modulation specified for the corresponding OFDM symbols by the second communication protocol.

The second communication protocol conforms to the Institute for Electrical and Electronics Engineers (IEEE) 802.11n Standard.

The third communication protocol conforms to the IEEE 802.11a Standard.

The fourth communication protocol conforms to the IEEE 802.11ac Standard.

The first communication protocol is a communication protocol that supports a higher throughput than the IEEE 802.11ac Standard.

In still another embodiment, an apparatus comprises a network interface configured to generate a preamble of the data unit, wherein the preamble includes a first field having a plurality of orthogonal frequency division multiplexing (OFDM) symbols, including at least (i) a first OFDM symbol, (ii) a second OFDM symbol, and (iii) a third OFDM symbol. The first OFDM symbol is formatted such that the first OFDM symbol is decodable by a receiver device that conforms to a second communication protocol, but does not conform to the

first communication protocol, to determine that the data unit conforms to a third communication protocol. The second OFDM symbol is formatted such that the first OFDM symbol and the second OFDM symbol are decodable by a receiver device that conforms to a fourth communication protocol, but does not conform to the first communication protocol, to determine that the data unit conforms to the third communication protocol. The third OFDM symbol is formatted such that a receiver device that conforms to the first communication protocol can determine that the data unit conforms to the first communication protocol. The network interface is also configured to generate the data unit to include at least the preamble.

In other embodiments, the apparatus includes any combination of one or more of the following features.

The network interface is further configured to generate a second field of the preamble, wherein the second field (i) substantially conforms to the third communication protocol, and (ii) includes a rate and a length subfield that indicate the duration of the data unit.

The network interface is configured to modulate the first OFDM symbol using the same modulation as the second OFDM symbol, wherein the modulation is different than the modulation specified for the corresponding OFDM symbols by the second communication protocol.

BRIEF DESCRIPTION OF THE DRAWINGS

FIG. 1 is a block diagram of an example wireless local area network (WLAN) 10, according to an embodiment;

FIGS. 2A and 2B are diagrams of a prior art data unit format;

FIG. 3 is a diagram of another prior art data unit format;

FIG. 4 is a diagram of another prior art data unit format;

FIG. 5 is a diagram of another prior art data unit format;

FIG. 6A illustrates diagrams of modulation used to modulate symbols in a prior art data unit;

FIG. 6B illustrates diagrams of modulation used to modulate symbols in an example data unit, according to an embodiment;

FIG. 7A is a diagram of an example data unit format, according to an embodiment;

FIGS. 7B-7D are diagrams illustrating modulation of the signal fields of the example data unit format of FIG. 7A, according to an embodiment;

FIGS. 8A-8F are diagrams of example bit allocations for a signal field, according to an embodiment.

FIGS. 9A-9C are diagrams depicting several example cyclic redundancy check (CRC) generation schemes, according to several embodiments.

FIG. 10 is a block diagram depicting a detection scheme for detecting whether a data unit conforms to a first communication protocol or to a second communication protocol, according to an embodiment.

FIG. 11 is a block diagram depicting another detection scheme for detecting whether a data unit conforms to a first communication protocol or to a second communication protocol, according to an embodiment.

FIG. 12 is a block diagram depicting yet another detection scheme for detecting whether a data unit conforms to a first communication protocol or to a second communication protocol, according to an embodiment.

FIG. 13A is a diagram of an example data unit format, according to an embodiment.

FIG. 13B illustrates diagrams of modulation used to modulate symbols in the data unit depicted in FIG. 13A, according to an embodiment;

FIG. 14A is a diagram of an example data unit format, according to an embodiment

FIG. 14B illustrates diagrams of modulation used to modulate symbols in the data unit depicted in FIG. 14A, according to an embodiment;

FIG. 15 is a diagram of a method for generating a data unit, according to an embodiment;

FIG. 16 is a diagram of a method for detecting whether a data unit conforms to a first communication protocol or to a second communication protocol, according to an embodiment.

FIG. 17 is a diagram of a method for generating a data unit, according to an embodiment.

DETAILED DESCRIPTION

In embodiments described below, a wireless network device such as an access point (AP) of a wireless local area network (WLAN) transmits data streams to one or more client stations. The AP is configured to operate with client stations according to at least a first communication protocol. The first communication protocol, according to some embodiments, is referred herein as “ultra high throughput” or “UHT” communication protocol. In some embodiments, different client stations in the vicinity of the AP are configured to operate according to one or more other communication protocols which define operation in the same frequency band as the UHT communication protocol but with generally lower data throughputs. The lower data throughput communication protocols (e.g., IEEE 802.11a, IEEE 802.11n, and/or IEEE 802.11ac) are collectively referred herein as “legacy” communication protocols. When the AP transmits a data unit according to the UHT communication protocol, a preamble of the data is formatted such that a client station that operates according to a legacy protocol, and not the UHT communication protocol, is able to determine certain information regarding the data unit, such as a duration of the data unit, and/or that the data unit does not conform to the second protocol. Additionally, a preamble of the data unit is formatted such that a client station that operates according to the UHT protocol is able to determine the data unit conforms to the UHT communication protocol. Similarly, a client station configured to operate according to the UHT communication protocol also transmits data units such as described above.

In at least some embodiments, data units formatted such as described above are useful, for example, with an AP that is configured to operate with client stations according to a plurality of different communication protocols and/or with WLANs in which a plurality of client stations operate according to a plurality of different communication protocols. Continuing with the example above, a communication device configured to operate according to both the UHT communication protocol and a legacy communication protocol is able to determine that the data unit is formatted according to the UHT communication protocol and not the legacy communication protocol. Similarly, a communication device configured to operate according to a legacy communication protocol but not the UHT communication protocol is able to determine that the data unit is not formatted according to the legacy communication protocol and/or determine a duration of the data unit.

FIG. 1 is a block diagram of an example wireless local area network (WLAN) 10, according to an embodiment. An AP 14 includes a host processor 15 coupled to a network interface 16. The network interface 16 includes a medium access control (MAC) processing unit 18 and a physical layer (PHY) processing unit 20. The PHY processing unit 20 includes a

plurality of transceivers 21, and the transceivers 21 are coupled to a plurality of antennas 24. Although three transceivers 21 and three antennas 24 are illustrated in FIG. 1, the AP 14 includes other suitable numbers (e.g., 1, 2, 4, 5, etc.) of transceivers 21 and antennas 24 in other embodiments. In one embodiment, the MAC processing unit 18 and the PHY processing unit 20 are configured to operate according to a first communication protocol (e.g., UHT communication protocol). In another embodiment, the MAC processing unit 18 and the PHY processing unit 20 are also configured to operate according to a second communication protocol (e.g., IEEE 802.11ac Standard). In yet another embodiment, the MAC processing unit 18 and the PHY processing unit 20 are additionally configured to operate according to the second communication protocol, a third communication protocol and/or a fourth communication protocol (e.g., the IEEE 802.11a Standard and/or the IEEE 802.11n Standard).

The WLAN 10 includes a plurality of client stations 25. Although four client stations 25 are illustrated in FIG. 1, the WLAN 10 includes other suitable numbers (e.g., 1, 2, 3, 5, 6, etc.) of client stations 25 in various scenarios and embodiments. At least one of the client stations 25 (e.g., client station 25-1) is configured to operate at least according to the first communication protocol. In some embodiments, at least one of the client stations 25 is not configured to operate according to the first communication protocol but is configured to operate according to at least one of the second communication protocol, the third communication protocol and/or the fourth communication protocol (referred to herein as a “legacy client station”).

The client station 25-1 includes a host processor 26 coupled to a network interface 27. The network interface 27 includes a MAC processing unit 28 and a PHY processing unit 29. The PHY processing unit 29 includes a plurality of transceivers 30, and the transceivers 30 are coupled to a plurality of antennas 34. Although three transceivers 30 and three antennas 34 are illustrated in FIG. 1, the client station 25-1 includes other suitable numbers (e.g., 1, 2, 4, 5, etc.) of transceivers 30 and antennas 34 in other embodiments.

According to an embodiment, the client station 25-4 is a legacy client station, i.e., the client station 25-4 is not enabled to receive and fully decode a data unit that is transmitted by the AP 14 or another client station 25 according to the first communication protocol. Similarly, according to an embodiment, the legacy client station 25-4 is not enabled to transmit data units according to the first communication protocol. On the other hand, the legacy client station 25-4 is enabled to receive and fully decode and transmit data units according to the second communication protocol, the third communication protocol and/or the fourth communication protocol.

In an embodiment, one or both of the client stations 25-2 and 25-3, has a structure the same as or similar to the client station 25-1. In an embodiment, the client station 25-4, has a structure similar to the client station 25-1. In these embodiments, the client stations 25 structured the same as or similar to the client station 25-1 have the same or a different number of transceivers and antennas. For example, the client station 25-2 has only two transceivers and two antennas, according to an embodiment.

In various embodiments, the PHY processing unit 20 of the AP 14 is configured to generate data units conforming to the first communication protocol and having formats described hereinafter. The transceiver(s) 21 is/are configured to transmit the generated data units via the antenna(s) 24. Similarly, the transceiver(s) 24 is/are configured to receive the data units via the antenna(s) 24. The PHY processing unit 20 of the AP 14 is configured to process received data units conforming to

the first communication protocol and having formats described hereinafter and to determine that such data units conform to the first communication protocol, according to various embodiments.

In various embodiments, the PHY processing unit **29** of the client device **25-1** is configured to generate data units conforming to the first communication protocol and having formats described hereinafter. The transceiver(s) **30** is/are configured to transmit the generated data units via the antenna(s) **34**. Similarly, the transceiver(s) **30** is/are configured to receive data units via the antenna(s) **34**. The PHY processing unit **29** of the client device **25-1** is configured to process received data units conforming to the first communication protocol and having formats described hereinafter and to determine that such data units conform to the first communication protocol, according to various embodiments.

FIG. 2A is a diagram of a prior art OFDM data unit **200** that the AP **14** is configured to transmit to the client station **25-4** via orthogonal frequency division multiplexing (OFDM) modulation, according to an embodiment. In an embodiment, the client station **25-4** is also configured to transmit the data unit **200** to the AP **14**. The data unit **200** conforms to the IEEE 802.11a Standard and occupies a 20 Megahertz (MHz) band. The data unit **200** includes a preamble having a legacy short training field (L-STF) **202**, generally used for packet detection, initial synchronization, and automatic gain control, etc., and a legacy long training field (L-LTF) **204**, generally used for channel estimation and fine synchronization. The data unit **200** also includes a legacy signal field (L-SIG) **206**, used to carry certain physical layer (PHY) parameters of with the data unit **200**, such as modulation type and coding rate used to transmit the data unit, for example. The data unit **200** also includes a data portion **208**. FIG. 2B is a diagram of example data portion **208** (not low density parity check encoded), which includes a service field, a scrambled physical layer service data unit (PSDU), tail bits, and padding bits, if needed. The data unit **200** is designed for transmission over one spatial or space-time stream in a single input single output (SISO) channel configuration.

FIG. 3 is a diagram of a prior art OFDM data unit **300** that the AP **14** is configured to transmit to the client station **25-4** via orthogonal frequency domain multiplexing (OFDM) modulation, according to an embodiment. In an embodiment, the client station **25-4** is also configured to transmit the data unit **300** to the AP **14**. The data unit **300** conforms to the IEEE 802.11n Standard, occupies a 20 MHz band, and is designed for mixed mode situations, i.e., when the WLAN includes one or more client stations that conform to the IEEE 802.11a Standard but not the IEEE 802.11n Standard. The data unit **300** includes a preamble having an L-STF **302**, an L-LTF **304**, an L-SIG **306**, a high throughput signal field (HT-SIG) **308**, a high throughput short training field (HT-STF) **310**, and M data high throughput long training fields (HT-LTFs) **312**, where M is an integer generally determined by the number of spatial streams used to transmit the data unit **300** in a multiple input multiple output (MIMO) channel configuration. In particular, according to the IEEE 802.11n Standard, the data unit **300** includes two HT-LTFs **312** if the data unit **300** is transmitted using two spatial streams, and four HT-LTFs **312** if the data unit **300** is transmitted using three or four spatial streams. An indication of the particular number of spatial streams being utilized is included in the HT-SIG field **308**. The data unit **300** also includes a data portion **314**.

FIG. 4 is a diagram of a prior art OFDM data unit **400** that the AP **14** is configured to transmit to the client station **25-4** via orthogonal frequency domain multiplexing (OFDM) modulation, according to an embodiment. In an embodiment,

the client station **25-4** is also configured to transmit the data unit **400** to the AP **14**. The data unit **400** conforms to the IEEE 802.11n Standard, occupies a 20 MHz band, and is designed for “Greenfield” situations, i.e., when the WLAN does not include any client stations that conform to the IEEE 802.11a Standard but not the IEEE 802.11n Standard. The data unit **400** includes a preamble having a high throughput Greenfield short training field (HT-GF-STF) **402**, a first high throughput long training field (HT-LTF1) **404**, a HT-SIG **406**, and M data HT-LTFs **408**, where M is an integer which generally corresponds to a number of spatial streams used to transmit the data unit **400** in a multiple input multiple output (MIMO) channel configuration. The data unit **400** also includes a data portion **410**.

FIG. 5 is a diagram of a prior art OFDM data unit **500** that the client station AP **14** is configured to transmit to the client station **25-4** via orthogonal frequency domain multiplexing (OFDM) modulation, according to an embodiment. In an embodiment, the client station **25-4** is also configured to transmit the data unit **500** to the AP **14**. The data unit **500** conforms to the IEEE 802.11ac Standard and is designed for “Mixed field” situations. The data unit **500** occupies a 20 MHz bandwidth. In other embodiments or scenarios, a data unit similar to the data unit **500** occupies a different bandwidth, such as a 40 MHz, an 80 MHz, or a 160 MHz bandwidth. The data unit **500** includes a preamble having an L-STF **502**, an L-LTF **504**, an L-SIG **506**, two first very high throughput signal fields (VHT-SIGAs) **508** including a first very high throughput signal field (VHT-SIGA1) **508-1** and a second very high throughput signal field (VHT-SIGA2) **508-2**, a very high throughput short training field (VHT-STF) **510**, M very high throughput long training fields (VHT-LTFs) **512**, where M is an integer, and a second very high throughput signal field (VHT-SIG-B) **514**. The data unit **500** also includes a data portion **516**.

FIG. 6A is a set of diagrams illustrating modulation of the L-SIG, HT-SIG1, and HT-SIG2 fields of the data unit **300** of FIG. 3, as defined by the IEEE 802.11n Standard. The L-SIG field is modulated according to binary phase shift keying (BPSK), whereas the HT-SIG1 and HT-SIG2 fields are modulated according to BPSK, but on the quadrature axis (Q-BPSK). In other words, the modulation of the HT-SIG1 and HT-SIG2 fields is rotated by 90 degrees as compared to the modulation of the L-SIG field.

FIG. 6B is a set of diagrams illustrating modulation of the L-SIG, VHT-SIGA1, and VHT-SIGA2 fields of the data unit **500** of FIG. 5, as defined by the IEEE 802.11ac Standard. Unlike the HT-SIG1 field in FIG. 6A, the VHT-SIGA1 field is modulated according to BPSK, same as the modulation of the L-SIG field. On the other hand, the VHT-SIGA2 field is rotated by 90 degrees as compared to the modulation of the L-SIG field.

FIG. 7A is a diagram of an OFDM data unit **700** that the client station AP **14** is configured to transmit to the client station **25-1** via orthogonal frequency domain multiplexing (OFDM) modulation, according to an embodiment. In an embodiment, the client station **25-1** is also configured to transmit the data unit **700** to the AP **14**. The data unit **700** conforms to the first communication protocol and occupies a 20 MHz bandwidth. Data units similar to the data unit **700** occupy other suitable bandwidth such as 40 MHz, 80 MHz, 160 MHz, 320 MHz, 640 MHz, for example, or other suitable bandwidths, in other embodiments. The data unit **700** is suitable for “mixed mode” situations, i.e. when the WLAN includes a client station (e.g., the legacy client station **24-4**) that conforms to a legacy communication protocol, but not the

first communication protocol. The data unit **700** is utilized in other situations as well, in some embodiments.

The data unit **700** includes a preamble having an L-STF **702**, an L-LTF **704**, an L-SIG **706**, two first ultra high throughput signal fields (UHT-SIGAs) **708** including a first ultra high throughput signal field (UHT-SIGA1) **708-1** and a second ultra high throughput signal field (UHT-SIGA2) **708-2**, an ultra high throughput short training field (UHT-STF) **710**, M ultra high throughput long training fields (UHT-LTFs) **712**, where M is an integer, and a third ultra high throughput signal field (UHT-SIGB) **714**. In an embodiment, the UHT-SIGAs **708** comprise two OFDM symbols, where the UHT-SIGA1 **708-1** field comprises the first OFDM symbol and the UHT-SIGA2 comprises the second OFDM symbol. In at least some examples, the UHT-SIGAs **708** are collectively referred to as a single very high throughput signal field (UHT-SIGA) **708**. In some embodiments, the data unit **700** also includes a data portion **716**. In other embodiments, the data unit **700** omits the data portion **716**.

In the embodiment of FIG. 7A, the data unit **700** includes one of each of the L-STF **702**, the L-LTF **704**, the L-SIG **706**, the UHT-SIGA1s **708**. In other embodiments in which an OFDM data unit similar to the data unit **700** occupies a cumulative bandwidth other than 20 MHz, each of the L-STF **702**, the L-LTF **704**, the L-SIG **706**, the UHT-SIGA1s **708** is repeated over a corresponding number of 20 MHz sub-bands of the whole bandwidth of the data unit, in an embodiment. For example, in an embodiment, the OFDM data unit occupies an 80 MHz bandwidth and, accordingly, includes four of each of the L-STF **702**, the L-LTF **704**, the L-SIG **706**, the UHT-SIGA1s **708**, in an embodiment. In some embodiments, the modulation of different 20 MHz sub-bands signals is rotated by different angles. For example, in one embodiment, a first subband is rotated 0-degrees, a second subband is rotated 90-degrees, a third sub-band is rotated 180-degrees, and a fourth sub-band is rotated 270-degrees. In other embodiments, different suitable rotations are utilized. The different phases of the 20 MHz sub-band signals result in reduced peak to average power ratio (PAPR) of OFDM symbols in the data unit **700**, in at least some embodiments. In an embodiment, if the data unit that conforms to the first communication protocol is an OFDM data unit that occupies a cumulative bandwidth such as 20 MHz, 40 MHz, 80 MHz, 160 MHz, 320 MHz, 640 MHz, etc., the UHT-STF, the UHT-LTFs, the UHT-SIGB and the UHT data portion occupy the corresponding whole bandwidth of the data unit.

FIGS. 7B, 7C and 7D are diagrams illustrating modulation of the L-SIG **706**, UHT-SIGA1 **708-1**, and UHT-SIGA2 **708-2**, respectively, of the data unit **700** of FIG. 7A, according to an embodiment. In this embodiment, the L-SIG **706**, UHT-SIGA1 **708-1**, and UHT-SIGA2 **708-2** fields have the same modulation as the modulation of the corresponding field as defined in the IEEE 802.11ac Standard and depicted in FIG. 6B. Accordingly, the UHT-SIGA1 field is modulated the same as the L-SIG field. On the other hand, the UHT-SIGA2 field is rotated by 90 degrees as compared to the modulation of the L-SIG field.

In an embodiment, because the modulations of the L-SIG **706**, UHT-SIGA1 **708-1**, and UHT-SIGA2 **708-2** fields of the data unit **700** correspond to the modulations of the corresponding fields in a data unit that conforms to the IEEE 802.11ac Standard (e.g., the data unit **500** of FIG. 5), legacy client stations configured to operate according to the IEEE 802.11a Standard and/or the IEEE 802.11n Standard will assume, in at least some circumstances, that the data unit **700** conforms to the IEEE 802.11ac Standard and will process the data unit **700** accordingly. For example, a client station the

conforms to the IEEE 802.11a Standard will recognize the legacy IEEE 802.11a Standard portion of the preamble of the data unit **700** and will set the data unit duration according to a duration indicated in the L-SIG **706**. For example, the legacy client station will calculate a duration based on a rate and a length (e.g., in number of bytes) indicated in the L-SIG field **706**, according to an embodiment. In an embodiment, the rate and the length in the L-SIG field **706** are set such that a client station configured to operate according to a legacy communication protocol will calculate, based the rate and the length, a packet duration (T) that corresponds to, or at least approximates, the actual duration of the data unit **700**. For example, the rate is set to indicate a lowest rate defined by the IEEE 802.11a Standard (i.e., 6 Mbps), and the length is set to a value computed such that packet duration computed using the lowest rate at least approximates the actual duration of the data unit **700**, in one embodiment.

In an embodiment, a legacy client station that conforms to the IEEE 802.11a Standard, when receiving the data unit **700**, will compute a packet duration for the data unit **700**, e.g., using a rate and a length fields of L-SIG field **706**, and will wait until the end of the computed packet duration before performing clear channel assessment (CCA), in an embodiment. Thus, in this embodiment, communication medium is protected against access by the legacy client station at least for the duration of the data unit **700**. In an embodiment, the legacy client station will continue decoding the data unit **700**, but will fail an error check (e.g., using a frame check sequence (FCS)) at the end of the data unit **700**.

Similarly, a legacy client station configured to operate according to the IEEE 802.11n Standard, when receiving the data unit **700**, will compute a packet duration (T) of the data unit **700** based on the rate and the length indicated in the L-SIG **706** of the data unit **700**, in an embodiment. The legacy client station will detect the modulation of the first UHT signal field (UHT-SIGA1) **708-1** (BPSK) and will assume that the data unit **700** is a legacy data unit that conforms to the IEEE 802.11a Standard. In an embodiment, the legacy client station will continue decoding the data unit **700**, but will fail an error check (e.g., using a frame check sequence (FCS)) at the end of the data unit. In any event, according to the IEEE 802.11n Standard, the legacy client station will wait until the end of a computed packet duration (T) before performing clear channel assessment (CCA), in an embodiment. Thus, communication medium will be protected from access by the legacy client station for the duration of the data unit **700**, in an embodiment.

A legacy client station configured to operate according to the IEEE 802.11ac Standard but not the first communication protocol, when receiving the data unit **700**, will compute a packet duration (T) of the data unit **700** based on the rate and the length indicated in the L-SIG **706** of the data unit **700**, in an embodiment. However, the legacy client station will not be able to detect, based on the modulation of the data unit **700**, that the data unit **700** does not conform to the IEEE 802.11ac Standard, in an embodiment. In some embodiments, one or more UHT signal fields (e.g., the UHT-SIGA1 and/or the UHT-SIGA2) of the data unit **700** is/are formatted to intentionally cause the legacy client station to detect an error when decoding the data unit **700**, and to therefore stop decoding (or “drop”) the data unit **700**. For example, UHT-SIGA **708** of the data unit **700** is formatted to intentionally cause an error when the SIGA field is decoded by a legacy device according to the IEEE 802.11ac Standard, in an embodiment. Further, according to the IEEE 802.11ac Standard, when an error is detected in decoding the VHT-SIGA field, the client station will drop the data unit **700** and will wait until the end of a computed

packet duration (T), calculated, for example, based on a rate and a length indicated in the L-SIG 706 of the data unit 700, before performing clear channel assessment (CCA), in an embodiment. Thus, communication medium will be protected from access by the legacy client station for the duration of the data unit 700, in an embodiment.

FIGS. 8A-8F are diagrams of example bit allocations for various portions of the UHT-SIGA field 708, according to an embodiment. In particular, FIGS. 8A-8C are diagrams of example bit allocations for the UHT-SIGA1 field 708-1 (or portions of the UHT-SIGA1 field 708-1), and FIGS. 8D-8F are diagrams of example bit allocations for the UHT-SIGA2 field 708-2 (or portions of the UHT-SIGA1 field 708-2), according to an embodiment. The UHT-SIGA field 708 is generally formatted similar to a VHT-SIGA1 field as specified in the IEEE 802.11ac Standard, but one or more subfields of the UHT-SIGA field 708 are altered as compared to the corresponding subfields defined in the IEEE 802.11ac Standard and/or include values unsupported by the IEEE 802.11ac Standard to intentionally cause a legacy client station configured to operate according to the IEEE 802.11ac Standard to detect an error from the UHT-SIGA field 708, in some embodiments.

Referring to FIG. 8A, the UHT-SIGA1 field 708-1 includes a plurality of subfield 802 that collectively comprise 24 information bits, in the illustrated embodiment. The plurality of subfields 802 includes a 2-bit bandwidth (BW) subfield 802-1, a first 1-bit reserved subfield 802-2, a 1-bit space time block coding (STBC) subfield 802-3, a 6-bit Group Identification (Group ID) subfield 802-4, a 12-bit NSTS/Partial AID subfield 802-5, the content of which depends on whether the data unit 700 is a single user data unit (e.g., a data unit that used to transmit information to a single client station) or in a multiuser data unit (e.g., a data unit that includes independent data streams to multiple client stations), a 1-bit TXOP_PS_NOT_ALLOWED subfield 802-6, and a second 1-bit reserved subfield 802-7. FIGS. 8B and 8C are diagrams of the NSTS/Partial AID subfield 802-5 for a single user and a multi user data unit, respectively, according to an embodiment. Referring to FIG. 8B, in an embodiment in which the data unit 700 is a single user data unit, the NSTS/Partial AID subfield 802-5 comprises a 3-bit single user number of space-time streams subfield 802-5a and a 9-bit Partial AID subfield 802-5b. Referring to FIG. 8C, in an embodiment in which the data unit 700 is a multiuser data unit, the NSTS/Partial AID subfield 802-5 comprises four 3-bit user Nsts subfields 802-5c through 802-5f, where each of the user subfields 802-5c through 802-5f indicates a number of space time streams corresponding to a intended recipient of the signal field 800.

Referring to now FIG. 8D, the UHT-SIGA2 field 708-2 includes a plurality of subfield 810 that collectively comprise 24 information bits, in the illustrated embodiment. The plurality of subfields 810 includes a 1-bit Short GI subfield 810-1, a 1-bit Short GI NSYM Disambiguation subfield 810-2, a 1-bit SU/MU[0] Coding subfield 910-3, a 1-bit LDPC Extra OFDM Symbol subfield 810-4, a 12-bit SU MCS/MU [1-3] Coding subfield 910-5, the content of which depends on whether the data unit 700 is a single user data unit or a multiuser data unit, a 1-bit beamsteering/reserved subfield 810-6, a reserved subfield 810-7, an 8-bit cyclic redundancy check (CRC) subfield 810-8, and a tail subfield 801-9. FIGS. 8E and 8F are diagrams of the SU MCS/MU[1-3] Coding subfield 810-5 for a single user and a multi user data unit, respectively. Referring to FIG. 8E, in an embodiment in which the data unit 700 is a single user data unit, the SU MCS/MU[1-3] Coding subfield 810-5 comprises a 4-bit single SU MCS subfield 810-5a. Referring to FIG. 8F, in an

embodiment in which the data unit 700 is a multiuser data unit, the SU MCS/MU[1-3] Coding subfield 810-5 comprises four 1-bit subfields 810-5b through 810-5e, where each of the subfields 810-5b through 810-5d indicates a coding utilized for a particular intended recipient of the signal field 810, and the subfield 810-5e is reserved.

In some embodiments, a signal field of a data unit that conforms to the first communication protocol (e.g., the UHT-SIGA field 708 of the data unit 700) is formatted similarly to a corresponding signal field of a legacy data unit specified by a legacy communication protocol (e.g., the VHT-SIGA as specified in the IEEE 802.11ac Standard), but with a set of one or more information bits generated differently than the corresponding information bits generated according to the legacy communication protocol. For example, the set of one or more information bits includes information bits generated an error detection scheme (e.g., CRC) not specified by the legacy communication protocol, in an embodiment. As another example, the set of one or more information bits includes information bits set to indicate a mode not supported by the legacy communication protocol, in an embodiment. The differences between the signal field formatted according to the first communication protocol and a signal field formatted according to the legacy communication protocol cause a receiving device that conforms to the second communication protocol, but not the first communication protocol, to detect an error when decoding a signal field of a data unit that conforms to the first communication protocol, in at least some embodiments and/or scenarios. Further, such differences permit a receiver device that conforms to the first communication protocol whether a data unit being received conforms to the first communication protocol or to a legacy communication protocol, in at least some embodiments.

For example, in some embodiments, CRC to be included in the CRC subfield 810-8 (FIG. 8C) is generated differently than CRC specified for the VHT-SIGA field by the IEEE 802.11ac Standard. The different CRC for the UHT-SIGA 708 field will cause a CRC error when the UHT-SIGA field 708 is decoded by a client station that conforms to the IEEE 802.11ac Standard, but not the first communication protocol, in an embodiment. Further, the different CRC will permit a client station that conforms to the first communication protocol to determine that the data unit 700 conforms to the first communication protocol, in an embodiment.

FIGS. 9A-9C are diagrams depicting several example CRC generation schemes 950, 960, 970 used for generating CRC for a UHT-SIGA field of a data unit that conforms to the first communication protocol, according to some embodiments. In various embodiments, the CRC generation schemes 950, 960, 970 are used to generate the CRC subfield 810-8 (FIG. 8D) or a CRC field for another suitable UHT-SIGA field of a data unit that conforms to the first communication protocol.

Referring to FIG. 9A, according to the CRC generation scheme 950, an 8-bit CRC for the UHT-SIGA field is generated using a polynomial that is different from the polynomial specified for the VHT-SIGA field in the IEEE 802.11ac Standard, in an embodiment. For example, an 8-bit polynomial at least substantially orthogonal to the polynomial specified for the VHT-SIGA field is utilized at block 952, in one embodiment. In other embodiments, other suitable polynomials different from the CRC polynomial specified for the VHT-SIGA field are utilized at block 952. Referring now to FIG. 9B, according to the CRC generation scheme 960, an 8-bit CRC for the UHT-SIGA 708 is generated using the polynomial specified for the VHT-SIGA field in the IEEE 802.11ac Standard (block 962), but one or more bits of the generated CRC

are flipped (i.e., “0” changed to “1” and “1” changed to “0”), or otherwise encrypted (block **964**), in this embodiment.

Referring now to FIG. **9C**, according to the CRC generation scheme **970**, a CRC having less bits than the 8-bit CRC specified for the VHT-SIGA field in the IEEE 802.11ac Standard is generated for the UHT-SIGA field, in an embodiment. For example, a 4-bit CRC is generated for the UHT-SIGA, in some embodiments. The 4-bit CRC is generated, for example, using the polynomial specified for the VHT-SIGA field in the IEEE 802.11ac Standard (block **972**). Then, a 4-bit subset of the generated CRC (block **974**) is selected. For example, the four most significant bits (MSB) or the four most significant bits (LSB) of the generated CRC (block **974**) are selected, in some embodiments. Further, one or more bits of the selected 4-bit CRC are flipped (i.e., “0” changed to “1” and “1” changed to “0”), or otherwise encrypted (block **976**), in this embodiment. In other embodiments, the CRC generation scheme **970** generates a CRC that is another suitable number of bits less than 8 (e.g., 7 bits, 6 bits, 5 bits, etc.). For example, a 5-bit CRC is generated using the polynomial specified for the VHT-SIGA field in the IEEE 802.11ac Standard, selecting five most significant bits (MSB) of the generated CRC, the five least significant bits (LSB) of the generated CRC, or another 5-bit subset of the generated CRC, and encrypting (e.g., flipping) one or more bits of the resulting 5-bit CRC, in some embodiments. In some embodiments in which fewer CRC bits are utilized (e.g., fewer than 8), the remaining bit locations of the UHT-SIGA field (e.g., the other ones of MSBs or LSBs of the CRC subfield **810-8** of FIG. **8D**) are reserved and/or are utilized to signal additional information relevant to the first communication protocol.

While FIGS. **9A-9C** depict several example CRC generation schemes utilized for the UHT-SIGA field **708** according to some embodiments, in general, any CRC generation scheme different than a CRC generation scheme specified for the VHT-SIGA field by the IEEE 802.11ac Standard can be utilized, and other suitable CRC generation are utilized to generate CRC for the UHT-SIGA field **708** in other embodiments.

As just an example, in some embodiments, CRC having less bits than the 8-bit CRC specified for the VHT-SIGA field in the IEEE 802.11ac Standard is generated for the UHT-SIGA field using a polynomial that is different from the polynomial specified by the IEEE 802.11ac Standard. For example, an x-bit CRC is generated using an x-bit polynomial designed such that the generated CRC is at least substantially uncorrelated with the corresponding bits of the VHT-SIGA CRC generated according to the IEEE 802.11ac Standard, where x is an integer between 1 and 7, in some embodiments. In some such embodiments, the remaining bit locations of the UHT-SIGA field that correspond to bit locations of the CRC subfield of a VHT-SIGA field defined by the IEEE 802.11ac Standard (e.g., the other ones of MSBs or LSBs of the CRC subfield **910-8** of FIG. **8D**) are reserved or are utilized to signal additional information relevant to the first communication protocol.

In an embodiment, differences in CRC generation for the UHT-SIGA field according to the first communication protocol and for the VHT-SIGA field as defined in the IEEE 802.11ac Standard will cause a legacy client station configured to operate according to the IEEE 802.11ac Standard to detect a CRC error when decoding the data unit **700** and to therefore drop the data unit **700**. Further, differences in CRC generation for the UHT-SIGA field according to the first communication protocol and for the VHT-SIGA field defined in the IEEE 802.11ac Standard will permit a client station configured to operate according to the first communication

protocol, when receiving a data unit, to detect whether the data unit conforms to the first communication protocol or to the IEEE 802.11ac Standard.

FIG. **10** is a block diagram depicting a detection scheme **1000** used by a client station (e.g., the client station **25-1**) configured to operate according the first communication protocol to determine whether a data unit conforms to the first communication protocol or to a legacy communication protocol (e.g., the IEEE 802.11ac Standard), according to an embodiment. The detection scheme **1000** is suitable for use in embodiments in which the UHT-SIGA field of data units conforming to the first communication protocol include a CRC having the same number of bits as CRC specified for a corresponding field by the legacy communication protocol (e.g., 8 bits). According to the detection scheme **1100**, a client station receiving a data unit decodes the SIGA field of the data unit. After decoding the signal field, the client station excludes CRC bits and BCC tail bits from the decoded SIGA field to generate a set of bits based on which a CRC for the SIGA field of the data unit should be generated, in an embodiment. Then, a first CRC for the SIGA field is generated (block **1002**) based on the set of bits and using a CRC generation scheme specified in the first communication protocol. A second CRC for the SIGA field is generated (block **1004**) based on the set of bits and using a CRC generation scheme specified in the legacy communication protocol (e.g., the IEEE 802.11ac Standard). The first generated CRC and the second generated CRC is each compared (block **1006**) to the received CRC that was received in the SIGA field of the data unit. When a match is detected between the received CRC and the first generated CRC, it is determined that the data unit conforms to the first communication protocol, in an embodiment. On the other hand, when a match is detected between the received CRC and the second generated CRC, it is determined that the data unit conforms to the legacy communication protocol (e.g., the IEEE 802.11ac Standard), in an embodiment.

FIG. **11** is a block diagram depicting a detection scheme **1100** used by a client station (e.g., the client station **25-1**) configured to operate according the first communication protocol to detect to whether a data unit conforms to the first communication protocol or to a legacy communication protocol, according to another embodiment. The detection scheme **1100** is suitable for use in embodiments in which the UHT-SIGA field of data units conforming to the first communication protocol include fewer bits (e.g., 4 bits) than the number of CRC bits specified for a corresponding field by the legacy communication protocol, according to an embodiment. According to the detection scheme **1100**, the client station, when receiving a data unit, decodes the SIGA field of the data unit. The client station then excludes CRC bits and BCC tail bits from the decoded SIGA field to generate a set of bits based on which CRC for the SIGA field should be generated. Then, a first CRC for the received SIGA field is generated (block **1102**) based on the set of bits and using the CRC generation scheme specified in the first communication protocol. In the embodiment of FIG. **11**, CRC according to the field communication protocol is generated using a CRC polynomial specified for the corresponding field by the legacy communication protocol, selecting a subset of bits of the generated CRC (e.g., four LSBs, four MSBs, another suitable subset of CRC bits, etc.) to be utilized for the first CRC, and encrypting one or more bits in the selected subset to generate the first CRC. A second CRC for the SIGA field is generated (block **1104**) based on the set of bits and according to the CRC generation scheme specified in the IEEE 802.11ac Standard and using four LSB or four MSB of the generated CRC as the

second CRC. The first generated CRC and the second generated CRC are compared (block 1106) to the corresponding bits of the CRC that was received in the SIGA field of the data unit. When a match is detected between the received CRC and the first generated CRC, it is determined that the data unit conforms to the first communication protocol, in an embodiment. On the other hand, when a match is detected between the received CRC and the second generated CRC, it is determined that the data unit conforms to the legacy communication protocol (e.g., the IEEE 802.11ac Standard), in an embodiment.

In some embodiments, in addition to or instead of using CRC to intentionally cause a legacy station to detect an error from the UHT-SIGA field 708, one or more subfields of the UHT-SIGA field 708 are set to indicate a mode that is not supported by legacy client stations configured to operate according to the legacy communication protocol to intentionally cause a legacy station to detect an error from the UHT-SIGA field 708. For example, the UHT-SIGA field 708 includes an indication of a modulation and coding scheme not supported by a legacy client station operating according to the IEEE 802.11ac Standard to intentionally cause the legacy client station to detect an error when decoding the UHT-SIGA field 708, and an embodiment. As another example, in some embodiments, the UHT-SIGA field 708 includes subfield combination that is not supported or “unallowable” according to the IEEE 802.11ac Standard. For example, for a single user data unit, the Group ID subfield of the UHT-SIGA field 708 is set to a value of 0 or 63 and the SU MCS field 902-5b is set to indicate an MCS greater than 9, in an embodiment. As another example, in another embodiment, the STBC subfield 902-3 and the SU NSTS subfield 902-5a are both set to a logic one (1). As yet another example, in yet another embodiment, for a multi-user data unit, the STBC subfield 902-3 and each of Nsts subfields 902-5c through 902-5f is set to a logic one (1). In other embodiments, other SIGA subfield combinations unallowable in the IEEE 802.11ac Standard are utilized in the UHT-SIGA field 708 to intentionally cause an error when the UHT-SIG field 708 is decoded by a legacy client station. Further, such unallowable combinations included in the UHT-SIGA field 708 of the data unit 700 indicate to a client station that conforms to the first communication protocol that the data unit 700 conforms to the first communication protocol, in some embodiments.

In some embodiments, one or more additional indications is/are included in the UHT-SIGA field 708 of the data unit 700 to indicate to a client station configured to operate according to the first communication protocol that the data unit 700 conforms to the first communication protocol. For example, a subfield that corresponds to a reserved subfield in a VHT-SIGA field generated according to the IEEE 802.11ac Standard is set to a logic zero (0) in the UHT-SIGA field 708 to indicate to a client station configured to operate according to the first communication protocol that the data unit 700 conforms to the first communication protocol. In this embodiment, a client station operating according to the first communication protocol, when receiving a data unit, determines that the data unit conforms to the first communication protocol if the reserved bit in the UHT-SIGA field is set of logic zero (0) and determines that the data unit conforms to the IEEE 802.11ac Standard if the reserved bit is set to a logic one (1), in an embodiment.

In some embodiments, at least some portions (e.g., subfields) of a UHT-SIGA field (e.g., the UHT-SIGA field 708) that are not used to intentionally cause an error at a legacy device are not formatted the same as the corresponding portions (e.g., subfields) of a VHT-SIGA field specified by the

IEEE 802.11ac Standard. For example, such portions are altered to include additional information relevant to the first communication protocol, in some embodiments. For example, whereas the VHT-SIGA field specified by the IEEE 802.11ac Standard includes two bits to indicate the BW of a data unit, some data units that conform, to the first communication protocol occupy wider bandwidth than the widest bandwidth specified by the IEEE 802.11ac Standard. Thus, in some embodiments, one or more extra bits are needed to signal the bandwidth for data units that conform to the first communication protocol. For example, in one embodiment, the UHT-SIGA field includes a 3-bit bandwidth indication. Additionally or alternatively, in some embodiments, extra signal field bits are utilized for the UHT-SIGA field to signal new physical layer (PHY) features that are not present in the IEEE 802.11ac Standard.

In some such embodiments, VHT-SIGA subfields that are reserved according to the IEEE 802.11ac Standard are utilized in the UHT-SIGA field to signal the wider bandwidth and/or additional PHY features according to the first communication protocol. Additionally or alternatively, in some embodiments in which UHT-SIGA utilizes a shorter than the eight bit CRC defined for VHT-SIGA in the IEEE 802.11ac Standard, bits corresponding to the remaining CRC bits of the VHT-SIGA field are utilized in the UHT-SIGA field to signal the wider bandwidth and/or additional PHY features according to the first communication protocol.

In some embodiments in which the UHT-SIGA field 708 includes an explicit indication to signal that the data unit 700 conforms to the first communication protocol, schemes designed to intentionally cause an error at a legacy client station are not employed for the UHT-SIGA field 708. For example, in an embodiment, CRC for the UHT-SIGA field 708 is generated using the VHT-SIGA CRC polynomial specified in the IEEE 802.11ac Standard and with the same number of bits as specified in the IEEE 802.11ac Standard. Further, in this embodiment, a subfield that corresponds to a reserved subfield in a VHT-SIGA field generated according to the IEEE 802.11ac Standard is set to a logic zero (0) in the UHT-SIGA field 708 to indicate to a client station configured to operate according to the first communication protocol that the data unit 700 conforms to the first communication protocol. In this case, a client station configured to operate according to the first communication protocol will determine that the data unit 700 conforms to the first communication protocol based on the indication included in the UHT-SIGA field 708. However, a legacy client station receiving the data unit 700, in this case, will not necessarily detect an error from the UHT-SIGA field 708 and will not necessarily drop the data unit 700. In some situations, in such embodiments, the legacy client station will drop the data unit 700 even without detecting an intentionally caused error from the UHT-SIGA field 708. For example, the legacy client station will determine that the partial address identification (PAID) and/or the group ID (GID) included in the UHT-SIGA field 708 do not match the corresponding parameters of the client station, and will drop (stop decoding) the data unit 700 based on this determination. In other embodiments, however, the legacy client station will not drop the data unit 700 even when the client station determines that the partial address identification (PAID) and/or the group ID (GID) included in the UHT-SIGA field 708 do not match the corresponding parameters of the client station. In this case, the client station will continue decoding the data unit 700 for the duration of the data unit 700, and will discard the data unit 700 based on a failed FCS check at the end of the data unit 700, in at least some situations.

In another embodiment, CRC for the UHT-SIGA field **708** is generated using the VHT-SIGA CRC polynomial specified in the IEEE 802.11ac Standard, but with fewer bits than specified in the IEEE 802.11ac Standard. For example, a CRC is generated using the VHT-SIGA CRC polynomial and x number of the generated CRC is/are used as the CRC for the UHT-SIGA field **708**. For example, four (or another suitable number, such as e.g., 5 or 6) MSB or LSB of the CRC generated using the VHT-SIGA CRC polynomial are utilized, in some embodiments. In some such embodiments, the remaining bit locations of the CRC subfield are reserved or are utilized to signal additional information relevant to the first communication protocol. In such embodiments, although CRC is not intentionally designed to cause an error from the UHT-SIGA field at a legacy client device, it is highly likely that such an error will be detected, in which case the client station will drop the data unit **700**. Further, in such embodiments, a client station configured to operate according to the first communication protocol will perform a CRC check for the UHT-SIGA field **708** by generating CRC based on received bits of the UHT-SIGA field **708** using the CRC polynomial specified for the VHT-SIGA field in the IEEE 802.11ac Standard and comparing 4 (or another suitable number, such as e.g., 5 or 6) MSB or LSB of the generated CRC to the received CRC in the UHT-SIGA field. Upon passing the CRC check, the client station will decode the received UHT-SIGA field and will determine that the data unit **700** conforms to the first communication protocol based on the indication included in the UHT-SIGA field.

FIG. **12** is a diagram of an OFDM data unit **1200** that the client station AP **14** is configured to transmit to the client station **25-1** via orthogonal frequency domain multiplexing (OFDM) modulation, according to an embodiment. In an embodiment, the client station **25-1** is also configured to transmit the data unit **1200** to the AP **14**. The data unit **1200** conforms to the first communication protocol and occupies a 20 MHz bandwidth. Data units similar to the data unit **1200** occupy other suitable bandwidth such as 40 MHz, 80 MHz, 160 MHz, 320 MHz, 640 MHz, for example, or other suitable bandwidths, in other embodiments. The data unit **1200** is suitable for “mixed mode” situations, i.e. when the WLAN **10** includes a client station (e.g., the legacy client station **24-4**) that conforms to a legacy communication protocol, but not the first communication protocol. The data unit **1200** is utilized in other situations as well, in some embodiments.

The data unit **1200** is similar to the data unit **700** of FIG. **7A**, except that the data unit **1200** includes two UHT-SIGB fields **1204** as compared to a single UHT-SIG field **714** included in the data unit **700**. Further, UHT-SIGA fields **1202** are different from the UHT-SIGA fields **708** of the data unit **700**, in some embodiments. For example, one or more information bits of the UHT-SIGA fields **708** are moved from the UHT-SIGA fields **1202** to the UHT-SIGB fields **1204**, on an embodiment. For example, one or more information bits that are not required for determining appropriate processing of the UHT-LTFs **712** are moved to the UHT-SIGB fields **1204**, in some embodiments. Various UHT-SIGA generation schemes used to intentionally cause a legacy client station to detect an error from the UHT-SIGA and/or to indicate to a client station configured to operate according to the first communication protocol that the data unit **700** conforms to the first communication protocol are applied to the UHT-SIGA fields **1202**, in at least some embodiments.

FIG. **13A** is a diagram of an OFDM data unit **1300** that the client station AP **14** is configured to transmit to the client station **25-1** via orthogonal frequency domain multiplexing (OFDM) modulation, according to an embodiment. In an

embodiment, the client station **25-1** is also configured to transmit the data unit **1300** to the AP **14**. The data unit **1300** conforms to the first communication protocol and occupies a 20 MHz bandwidth. Data units similar to the data unit **1300** occupy other suitable bandwidth such as 40 MHz, 80 MHz, 160 MHz, 320 MHz, 640 MHz, or other suitable bandwidths, in other embodiments. The data unit **1300** is suitable for “mixed mode” situations, i.e. when the WLAN **10** includes a client station (e.g., the legacy client station **24-4**) that conforms to a legacy communication protocol, but not the first communication protocol. The data unit **1300** is utilized in other situations as well, in some embodiments.

The data unit **1300** is similar to the data unit **700** of FIG. **7A**, except that the data unit **1200** includes three UHT-SIGA fields **1302** as compared to two UHT-SIGA field **708** included in the data unit **700**. In some embodiments, data unit similar to the data unit **1300** include other suitable numbers (e.g., 4, 5, 6, etc.) of the UHT-SIGA fields **1302**. Each UHT-SIGA field **1302** comprises one OFDM symbol of the data unit **1300**, in an embodiment. Additional UHT-SIGA fields **1320** as compared to the two UHT-SIGA fields **708** of the data unit **700** are utilized to carry additional information relevant to the first communication protocol, for example to signal wider bandwidths defined in the first communication protocol, or to signal additional PHY features included in the first communication protocol. In some embodiments, UHT-SIGB field **1308** is omitted from the data unit **1300**, and at least some of the Information included in the UHT-SIGB field **1308** (e.g., MU information) is moved to the UHT-SIGA fields **1302**, in some such embodiments.

FIG. **13B** is a set of diagrams illustrating modulation of the L-SIG **706**, UHT-SIGA1 **1302-1**, and UHT-SIGA2 **1302-2**, and UHT-SIGA2 **1302-2** of the data unit **1300** of FIG. **13A**, according to an embodiment. In this embodiment, the L-SIG **706**, the UHT-SIGA1 **1302-1**, and the UHT-SIGA2 **1302-2** fields are modulated according to BPSK modulation, signaling to legacy client stations configured to operate to the IEEE 802.11a Standard and/or the IEEE 802.11n Standard that the data unit **1300** conforms to the IEEE 802.11a Standard. Accordingly, legacy client stations configured to operate to the IEEE 802.11a Standard, the IEEE 802.11n Standard and/or the IEEE 802.11ac will process the data unit **1300** in the same manner that such devices would treat an IEEE 802.11a packet, in at least some embodiments and/or scenarios. For example, a legacy client station will compute, based on the L-SIG field **706**, a packet duration for the data unit **1300**, and will wait until the end of the computed packet duration before performing clear channel assessment (CCA), in an embodiment. Further, a client station configured to operate according to the first communication protocol will detect the modulation of the UHT-SIGA3 field **1302-3** (e.g., Q-BPSK) and, based on the detected modulation, will determined that the data unit **1300** conforms to the first communication protocol, in an embodiment.

FIG. **14A** is a diagram of an OFDM data unit **1400** that the client station AP **14** is configured to transmit to the client station **25-1** via orthogonal frequency domain multiplexing (OFDM) modulation, according to an embodiment. In an embodiment, the client station **25-1** is also configured to transmit the data unit **1400** to the AP **14**. The data unit **1400** conforms to the first communication protocol and occupies a 20 MHz bandwidth. Data units similar to the data unit **1400** occupy other suitable bandwidth such as 40 MHz, 80 MHz, 160 MHz, 320 MHz, 640 MHz, or other suitable bandwidths, in other embodiments. The data unit **1400** is suitable for situations in which the WLAN **10** does not include any client

stations configured to operate to the IEEE 802.11a Standard but not the IEEE 802.11n Standard, in some embodiments.

The data unit **1400** includes a preamble having an ultra high throughput short training field (UHT-STF) **1402**, a first ultra high throughput long training field (UHT-LTF) **1404**, two legacy high throughput signal fields (HT-SIGs) **1406** including a first high throughput signal field (HT-SIG1) **1406-1** and a second high throughput signal field (HT-SIG2) **1406-2**, two ultra high throughput signal fields (UHT-SIGs) **1408** including a first ultra high throughput signal field (UHT-SIG1) **1408-1** and a second ultra high throughput signal field (UHT-SIG2) **1408-2**, M ultra high throughput long training fields (UHT-LTFs) **1410**, where M is an integer, and a third ultra high throughput signal field (UHT-SIGB) **714**. In an embodiment, the UHT-SIGs **1408** comprise two OFDM symbols, where the UHT-SIGA1 **1408-1** field comprises the first OFDM symbol and the UHT-SIGA2 **1408-2** comprises the second OFDM symbol. In at least some examples, the UHT-SIGs **1408** are collectively referred to as a single very high throughput signal field (UHT-SIGA) **1408**. In some embodiments, the data unit **1400** also includes a data portion **1414**. In other embodiments, the data unit **1400** omits the data portion **1414**.

In the embodiment of FIG. **1400A**, the data unit **1400** includes one of each of the UHT-STF **1402**, the UHT-LTF1 **1403**, the HT-SIG **1406** and the UHT-SIGA **1408**. In other embodiments in which an OFDM data unit similar to the data unit **1400** occupies a cumulative bandwidth other than 20 MHz, each of the UHT-STF **1402**, the UHT-LTF1 **1403**, the HT-SIG **1406** and the UHT-SIGA **1408** is repeated over a corresponding number of 20 MHz sub-bands of the whole bandwidth of the data unit, in an embodiment. For example, in an embodiment, the OFDM data unit occupies an 80 MHz bandwidth and, accordingly, includes four of each of the UHT-STF **1402**, the UHT-LTF1 **1403**, the HT-SIG **1406** and the UHT-SIGA **1408**. In some embodiments, the modulation of different 20 MHz sub-bands signals is rotated by different angles. For example, in one embodiment, a first subband is rotated 0-degrees, a second subband is rotated 90-degrees, a third sub-band is rotated 180-degrees, and a fourth sub-band is rotated 270-degrees. In other embodiments, different suitable rotations are utilized. The different phases of the 20 MHz sub-band signals result in reduced peak to average power ratio (PAPR) of OFDM symbols in the data unit **700**, in at least some embodiments.

Further, if the data unit conforming to the first communication protocol is an OFDM data unit that occupies a cumulative bandwidth such as 20 MHz, 40 MHz, 80 MHz, 160 MHz, 320 MHz, 640 MHz, etc., UHT-LTFs **1410**, the UHT-SIGB **1412** and the UHT data portion **1414** occupy the corresponding whole bandwidth of the data unit, according to an embodiment. Further, in an embodiment, each of the UHT-STF **1402**, the UHT-LTF1 **1403**, the HT-SIG **1406** and the UHT-SIGA **1408** are single stream fields mapped to multiple spatial streams of the data unit **1400** using a column (e.g., the first column) or a row (e.g., the first row) of a spatial stream mapping matrix ("P matrix") used for mapping multi-stream portion of the data unit **1400** e.g., the UHT-LTFs **1410**, the UHT-SIGB **1412** and the UHT data portion **1414**) to multiple spatial streams.

In some embodiments, data units similar to the data unit **1300** include other suitable numbers (e.g., 4, 5, 6, etc.) of the UHT-SIGA fields **1408**. Each UHT-SIGA field **1408** comprises one OFDM symbol, in an embodiment. Additional UHT-SIGA fields **1408** are utilized to carry additional information relevant to the first communication protocol, for example to signal wider bandwidths defined in the first com-

munication protocol, or to signal additional PHY features included in the first communication protocol, in some embodiments. Further, the UHT-SIGB field **1412** is omitted from the data unit **1400**, and at least some of the information included in the UHT-SIGB field **1412** (e.g., MU information) is moved to the UHT-SIGA fields **1406**, in some such embodiments.

FIG. **14B** is a set of diagrams illustrating modulation of HT-SIG1 **1406-1**, UHT-SIGA2 **1406-2**, and UHT-SIGA1 **1408-1** and UHT-SIGA2 **1408-2** of the data unit **1400** of FIG. **14A**, according to an embodiment. In the illustrated embodiment, HT-SIG1 **1406-1**, UHT-SIGA2 **1406-2**, and UHT-SIGA1 **1408-1** are modulated using Q-BPSK modulation. In an embodiment, legacy client stations configured to operate to the IEEE 802.11n Standard and/or the IEEE 802.11ac Standard detect Q-BPSK modulation of the HT-SIG1 **1406-1**, UHT-SIGA2 **1406-2**, and UHT-SIGA1 **1408-1** and, based on the detected modulation, will process the data unit **1400** as the legacy client station would process an IEEE 802.11n green-field packet. In such embodiments, the legacy client station will calculate a duration based on a rate and a length (e.g., in number of bytes) indicated in the HT-SIG field **1406** of the data unit **1400**. In an embodiment, the rate and the length in the HT-SIG field **1406** are set such that a client station configured to operate according to a legacy communication protocol will calculate, based the rate and the length, a packet duration (T) that corresponds to, or at least approximates, the actual duration of the data unit **1400**. For example, the rate is set to indicate a lowest rate defined by the IEEE 802.11n Standard (i.e., 6 Mbps), and the length is set to a value computed such that packet duration computed using the lowest rate at least approximates the actual duration of the data unit **1400**. A legacy client station, when receiving the data unit **1400**, will compute a packet duration for the data unit **1400**, and will wait until the end of the computed packet duration before performing clear channel assessment (CCA), in an embodiment. Further, a client station configured to operate according to the first communication protocol will detect the modulation of the UHT-SIGA2 field **1408-2** (e.g., Q-BPSK) of the data unit **1400** and will determine that the data unit **1400** conforms to the first communication protocol, according to an embodiment.

FIG. **15** is a flow diagram of an example method **1500** for generating a data unit, according to an embodiment. With reference to FIG. **1**, the method **1500** is implemented by the network interface **16**, in an embodiment. For example, in one such embodiment, the PHY processing unit **20** is configured to implement the method **1500**. According to another embodiment, the MAC processing **18** is also configured to implement at least a part of the method **1500**. With continued reference to FIG. **1**, in yet another embodiment, the method **1500** is implemented by the network interface **27** (e.g., the PHY processing unit **29** and/or the MAC processing unit **28**). In other embodiments, the method **1500** is implemented by other suitable network interfaces.

At block **1502**, a first field of a preamble of a data unit conforming to a first communication protocol is generated. Referring to FIG. **7**, in one embodiment, the L-SIG field **706** of the data unit **700** is generated. In another embodiment, another suitable first field is generated. The first field includes a first set of one or more information bits that indicate a duration of the data unit. The first field is formatted such that the first field decodable by a receiver device that conforms to a second communication protocol, but does not conform to the first communication protocol, to determine the duration of the data unit based on the first field. The first set of information bits corresponds, for example, to a rate subfield and a

length subfield of the preamble of the data unit, wherein the rate subfield and the length subfield are generated to allow the receiver device that conforms to the second communication protocol to compute at least an approximate duration of the data unit, in an embodiment. In another embodiment, the first set of information bits indicate other suitable information to allow a receiver device that conforms to the second communication protocol to determine a duration of the data unit.

In an embodiment, the first communication protocol is the UHT communication protocol and the second communication protocol is a legacy communication protocol such as the IEEE 802.11ac Standard. In other embodiments, the first communication protocol and/or the second communication protocol is another suitable communication protocol, including communication protocol not yet defined. For example, the second communication protocol is the UHT communication protocol, and the first communication protocol is a communication protocol defining even higher throughputs, in some embodiments.

At block **1504**, a second field of the preamble is generated. Referring to FIG. 7, in one embodiment, the UHT-SIGA field **708** of the data unit **700** is generated. In another embodiment, another suitable second field is generated. The second field includes a second set of one or more information bits that indicate to a receiver device that conforms to the first communication protocol that the data unit conforms to the first communication protocol. The second set of one or more information is generated according to an error detection scheme, such as a cyclic redundancy check (CRC) scheme, not specified by the second communication protocol, in an embodiment. For example, the second set of information bits is generated according to the CRC generation scheme **950** of FIG. 9A, the CRC generation scheme **960** of FIG. 9B or the CRC generation scheme **970** of FIG. 9C, in some example embodiments. In other embodiments, the second set of one or more information bits is generated according to other suitable error detection schemes not specified by the second communication protocol. Additionally or alternatively, the second set of one or more information bits is generated to indicate a mode not supported by the second communication protocol, such as a GID and MCS combination, or another suitable mode, not supported by the second communication protocol.

At block **1506**, the first field generated at block **1502** is modulation according to a modulation scheme specified for a field corresponding to the first field by the second communication protocol. For example, the first field is modulating using BPSK modulation, in an embodiment. In another embodiment, the first field is modulated using another suitable modulation scheme, such as Q-BPSK modulation or another suitable modulation specified for a field corresponding to the first field by the second communication protocol.

At block **1508**, the second field generated at block **1502** is modulation according to a modulation scheme specified for a field corresponding to the second field by the second communication protocol. For example, the second field comprises two OFDM symbols, wherein the first OFDM symbol is modulated using Q-BPSK modulation at block **1508** and the second OFDM symbol is modulation using BPSK modulation as specified by the second communication protocol, in one embodiment. In other embodiments, the second field is modulated at block **1508** using other suitable modulation schemes specified for a field corresponding to the second field by the second communication protocol.

At block **1510**, the preamble of the data unit is generated to include at least the first field and the second field. At block **1512**, the data unit is generated to include at least the preamble generated at block **1510**. In some embodiments, the

data unit is generated to further include a data portion. When the data unit is generated to include a data portion, the data portion is generated such that the data portion conforms to the first communication protocol, but does not conform to the second communication protocol, in some embodiments.

FIG. 16 is a flow diagram of an example method **1600**, according to an embodiment. With reference to FIG. 1, the method **1600** is implemented by the network interface **16**, in an embodiment. For example, in one such embodiment, the PHY processing unit **20** is configured to implement the method **1600**. According to another embodiment, the MAC processing **18** is also configured to implement at least a part of the method **1600**. With continued reference to FIG. 1, in yet another embodiment, the method **1600** is implemented by the network interface **27** (e.g., the PHY processing unit **29** and/or the MAC processing unit **28**). In other embodiments, the method **1600** is implemented by other suitable network interfaces.

At block **1602**, a data unit that conforms to a first communication protocol or to a second communication protocol is received. In an embodiment, the data unit is received by a receiver device via a communication channel. In an embodiment, the data unit **700** of FIG. 7 is received. In another embodiment, the data unit **500** of FIG. 5 is received. In another embodiment, another suitable data unit is received. In an embodiment, the first communication protocol is the UHT communication protocol and the second communication protocol is a legacy communication protocol such as the IEEE 802.11ac Standard. In other embodiments, the first communication protocol and/or the second communication protocol is another suitable communication protocol, including communication protocol not yet defined. For example, the second communication protocol is the UHT communication protocol, and the first communication protocol is a communication protocol defining even higher throughputs, in some embodiments.

At block **1604**, a field of a preamble of the data unit received at block **1602** is decoded. Referring to FIG. 7, in an embodiment, the UHT-SIGA field **708** of the data unit **700** is decoded. Referring to FIG. 5, the VHT-SIGA field **508** is decoded, in another embodiment. In another embodiment, another suitable field of a preamble of the data unit received at block **1602** is decoded. In an embodiment, decoding the field at block **1604** included decoding a received CRC included in the field decoded at block **1604**.

At block **1606**, a first CRC is generated based on the field decoded at block **1604**. The first CRC is generated using a first CRC generation scheme, the first CRC generation scheme specified for the field by the first communication protocol. For example, the first CRC is generated according to the CRC generation scheme **950** of FIG. 9A, the CRC generation scheme **960** of FIG. 9B or the CRC generation scheme **970** of FIG. 9C, in some example embodiments. In other embodiments, the first CRC is generated according to other suitable CRC generation schemes specified for the field by the first communication protocol.

At block **1608**, a second CRC is generated based on the field decoded at block **1604**. The second CRC is generated using a second CRC generation scheme, the second CRC generation scheme specified for the field by the second communication protocol. For example, the second CRC is generated according to the CRC generation scheme specified for the VHT-SIGA field in the IEEE 802.11ac Standard, in one embodiment. In other embodiments, the second CRC is generated according to other suitable schemes specified for the field by the second communication protocol.

At block **1610**, the first CRC generated at block **1606** and the second CRC generated at block **1608** are compared to the received CRC decoded at block **1604**. At block **1612**, it is determined whether the first generated CRC or the second generated CRC matches the received CRC. When it is determined at block **1612** that the first generated CRC matches the received CRC, the method continues at block **1614**, where it is determined that the data unit received at block **1602** conforms to the first communication protocol. On the other hand, when it is determined at block **1612** that the second generated CRC matches the received CRC, the method continues at block **1616**, where it is determined that the data unit received at block **1602** conforms to the second communication protocol.

FIG. **17** is a flow diagram of an example method **1700** for generating a data unit that conforms to a first communication protocol, according to an embodiment. With reference to FIG. **1**, the method **1700** is implemented by the network interface **16**, in an embodiment. For example, in one such embodiment, the PHY processing unit **20** is configured to implement the method **1700**. According to another embodiment, the MAC processing **18** is also configured to implement at least a part of the method **1700**. With continued reference to FIG. **1**, in yet another embodiment, the method **1700** is implemented by the network interface **27** (e.g., the PHY processing unit **29** and/or the MAC processing unit **28**). In other embodiments, the method **1700** is implemented by other suitable network interfaces.

At block **1702**, a preamble of the data unit is generated. In an embodiment, the preamble of the data unit **1300** in FIG. **13** is generated. In another embodiment, another suitable preamble is generated. The preamble includes a first field having a plurality of OFDM symbols. In an embodiment, the first field is the signal field **1302** in FIG. **13**. In another embodiment, the first field is another suitable first field. The first field includes at least a first OFDM symbol, a second OFDM symbol, and a third OFDM symbol.

The first OFDM symbol is formatted such that the first OFDM symbol is decodable by a receiver device that conforms to a second communication protocol, but does not conform to the first communication protocol, to determine that the data unit conforms to a third communication protocol. The first OFDM symbol is formatted, for example, as the UHT-SIGA1 **1302-1** of FIG. **13**, in an embodiment. In this embodiment, the first OFDM symbol is modulated according to BPSK modulation. In an embodiment, BPSK modulation of the first OFDM symbol causes a device that conforms to the second communication protocol (e.g., a legacy client station that conforms to the IEEE 802.11n Standard), to determine that the data unit conforms a third communication protocol (e.g., the IEEE 802.11a Standard).

The second OFDM symbol is formatted such that the second OFDM symbol and the first OFDM symbol are decodable by a receiver device that conforms to a fourth communication protocol, but does not conform to the first communication protocol, to determine that the data unit conforms to the third communication protocol. The second OFDM symbol is formatted, for example, as the UHT-SIGA2 **1302-2** of FIG. **13**, in an embodiment. In this embodiment, the second OFDM symbol is modulated according to BPSK modulation. In an embodiment, BPSK modulation of the first OFDM symbol, in combination with BPSK modulation of the first OFDM symbol, causes a device that conforms to the fourth communication protocol (e.g., a legacy client station that conforms to the IEEE 802.11ac Standard), to determine that the data unit conforms the third communication protocol (e.g., the IEEE 802.11a Standard).

The third OFDM symbol is formatted such a receiver device that conforms to the first communication protocol can determine that the data unit conforms to the first communication protocol. The third OFDM symbol is formatted, for example, as the UHT-SIGA3 **1302-3** of FIG. **13**, in an embodiment. In this embodiment, the third OFDM symbol is modulated according to Q-BPSK modulation. In an embodiment, Q-BPSK modulation of the third OFDM symbol causes a device that conforms to the first communication protocol (e.g., the UHT communication protocol), to determine that the data unit conforms the first communication protocol.

At block **1704**, the data unit is generated to include at least the preamble. In an embodiment, the data unit **1300** of FIG. **13** is generated. In an embodiment, the data unit **1300** is generated, wherein the data unit **1300** omits the data portion **716**. In another embodiment, the data unit **1300** is generated, wherein the data unit **1300** includes the data portion **716**. In other embodiments, other suitable data units are generated. When the data unit is generated to include a data portion, the data portion is generated such that the data portion conforms to the first communication protocol, and does not conform to either of the second communication protocol, the third communication protocol, and the fourth communication protocol, in some embodiments.

At least some of the various blocks, operations, and techniques described above may be implemented utilizing hardware, a processor executing firmware instructions, a processor executing software instructions, or any combination thereof. When implemented utilizing a processor executing software or firmware instructions, the software or firmware instructions may be stored in any computer readable memory such as on a magnetic disk, an optical disk, or other storage medium, in a RAM or ROM or flash memory, processor, hard disk drive, optical disk drive, tape drive, etc. Likewise, the software or firmware instructions may be delivered to a user or a system via any known or desired delivery method including, for example, on a computer readable disk or other transportable computer storage mechanism or via communication media. Communication media typically embodies computer readable instructions, data structures, program modules or other data in a modulated data signal such as a carrier wave or other transport mechanism. The term “modulated data signal” means a signal that has one or more of its characteristics set or changed in such a manner as to encode information in the signal. By way of example, and not limitation, communication media includes wired media such as a wired network or direct-wired connection, and wireless media such as acoustic, radio frequency, infrared and other wireless media. Thus, the software or firmware instructions may be delivered to a user or a system via a communication channel such as a telephone line, a DSL line, a cable television line, a fiber optics line, a wireless communication channel, the Internet, etc. (which are viewed as being the same as or interchangeable with providing such software via a transportable storage medium). The software or firmware instructions may include machine readable instructions that, when executed by the processor, cause the processor to perform various acts.

When implemented in hardware, the hardware may comprise one or more of discrete components, an integrated circuit, an application-specific integrated circuit (ASIC), etc.

While the present invention has been described with reference to specific examples, which are intended to be illustrative only and not to be limiting of the invention, changes, additions and/or deletions may be made to the disclosed embodiments without departing from the scope of the invention.

What is claimed is:

1. A method, comprising:

receiving a data unit, wherein the data unit conforms to a first communication protocol or to a second communication protocol;

decoding a field of a preamble of the data unit, including decoding a received cyclic redundancy check (CRC) included in the field;

generating, based on the field, a first CRC using a first CRC generation scheme, the first CRC generation scheme specified for the first field by the first communication protocol;

generating, based on the field, a second CRC using a second CRC generation scheme, the second CRC generation scheme specified for the field by the second communication protocol;

comparing (i) the first generated CRC and (ii) the second generated CRC to the received CRC;

determining that the data unit conforms to the first communication protocol when the first generated CRC matches the received CRC; and

determining that the data unit conforms to the second communication protocol when the second generated CRC matches the received CRC.

2. A method according to claim **1**, wherein:

generating the first CRC comprises generating the first CRC according to a first CRC polynomial, the first CRC polynomial specified for the field by the first communication protocol, and

generating the second CRC comprises generating the second CRC according to a second CRC polynomial, the second CRC polynomial specified for the field by the second communication protocol, wherein the second CRC polynomial is different than the first CRC polynomial.

3. A method according to claim **1**, wherein:

generating the first CRC comprises generating the first CRC according to a first CRC polynomial, the first CRC polynomial specified for the field by the first communication protocol, and

generating the second CRC comprises:
generating a plurality of CRC bits according to the first CRC polynomial, and
encrypting one or more bits of the plurality of CRC bits to generate the second CRC.

4. A method according to claim **1**, wherein:

generating the first CRC comprises generating the first CRC according to a first CRC polynomial, the first CRC polynomial specified for the field by the first communication protocol, and

generating the second CRC comprises:
generating a plurality of CRC bits according to the first CRC polynomial,
selecting a subset of the plurality of CRC bits, the subset to be utilized for the CRC for the second CRC; and
encrypting one or more bits in the selected subset of the plurality of CRC bits to generate the second CRC.

5. An apparatus, comprising:

a network interface configured to:

receive a data unit, wherein the data unit conforms to a first communication protocol or a second communication protocol;

decode a field of a preamble of the data unit, including decoding a received cyclic redundancy check (CRC) included in the field;

generate, based on the field, a first CRC using a first CRC generation scheme, the first CRC generation scheme specified for the first field by the first communication protocol;

generate, based on the field, a second CRC using a second CRC generation scheme, the second CRC generation scheme specified for the field by the second communication protocol;

compare the first generated CRC and the second generated CRC to the received CRC;

determine that the data unit conforms to the first communication protocol when the first generated CRC matches the received CRC; and

determine that the data unit conforms to the second communication protocol when the second generated CRC matches the received CRC.

6. Apparatus according to claim **5**, wherein the network interface is configured to:

generate the first CRC according to a first CRC polynomial, the first CRC polynomial specified for the field by the first communication protocol, and

generate the second CRC according to a second CRC polynomial, the second CRC polynomial specified for the field by the second communication protocol, wherein the second CRC polynomial is different than the first CRC polynomial.

7. Apparatus according to claim **5**, wherein the network interface is configured to:

generate the first CRC according to a first CRC polynomial, the first CRC polynomial specified for the field by the first communication protocol, and

generate the second CRC at least by:
generating a plurality of CRC bits according to the first CRC polynomial, and
encrypting one or more bits of the plurality of CRC bits to generate the second CRC.

8. Apparatus according to claim **5**, wherein the network interface is configured to:

generate the first CRC according to a first CRC polynomial, the first CRC polynomial specified for the field by the first communication protocol, and

generate the second CRC at least by:
generating a plurality of CRC bits according to the first CRC polynomial,
selecting a subset of the plurality of CRC bits, the subset to be utilized for the CRC for the second CRC; and
encrypting one or more bits in the selected subset of the plurality of CRC bits to generate the second CRC.

* * * * *