



(12) **United States Patent**
Lin et al.

(10) **Patent No.:** **US 9,123,468 B2**
(45) **Date of Patent:** **Sep. 1, 2015**

(54) **METHOD FOR FABRICATING SOLID ELECTROLYTIC CAPACITORS**

(71) Applicant: **APAQ TECHNOLOGY CO., LTD.**,
Miaoli County (TW)

(72) Inventors: **Ching-Feng Lin**, Hsinchu County (TW);
Ming-Tsung Chen, Changhua County (TW);
Shu-Yu Lin, Miaoli County (TW)

(73) Assignee: **APAQ TECHNOLOGY CO., LTD.**,
Miaoli County (TW)

(*) Notice: Subject to any disclaimer, the term of this patent is extended or adjusted under 35 U.S.C. 154(b) by 219 days.

(21) Appl. No.: **13/803,064**

(22) Filed: **Mar. 14, 2013**

(65) **Prior Publication Data**

US 2014/0259580 A1 Sep. 18, 2014

(51) **Int. Cl.**

H01G 9/00 (2006.01)
H01G 9/042 (2006.01)
H01G 9/045 (2006.01)
H01G 9/052 (2006.01)
H01G 9/15 (2006.01)

(52) **U.S. Cl.**

CPC **H01G 9/0029** (2013.01); **H01G 9/045** (2013.01); **H01G 9/0425** (2013.01); **H01G 9/052** (2013.01); **H01G 9/15** (2013.01); **Y10T 29/417** (2015.01)

(58) **Field of Classification Search**

CPC C25B 11/0405; H01L 31/0392; Y02E 60/122; H01G 9/045; H01G 9/012; H01G 9/07; H01G 9/0029; H01G 9/042; H01G 9/15; H01M 4/667; Y10T 29/417
USPC 29/25.03, 25.42; 361/502
See application file for complete search history.

(56) **References Cited**

U.S. PATENT DOCUMENTS

6,514,296 B1 * 2/2003 Tsai et al. 29/25.03
8,027,147 B2 * 9/2011 Miller et al. 361/502

* cited by examiner

Primary Examiner — Thiem Phan

(74) *Attorney, Agent, or Firm* — Lai & Cai Intellectual Property (USA) Office

(57) **ABSTRACT**

The instant disclosure relates to an improved method for the production of solid electrolytic capacitor, comprising the following steps. First, provide an insulating substrate. Next, form a plurality of conducting gels including aluminum powder on the insulating substrate. Thirdly, execute a high-temperature sintering process to metalize the conducting gels to form a plurality of aluminum plates. Next, form a dielectric layer on every aluminum plate. Then form an isolation layer on every dielectric layer to define an anodic region and a cathodic region. Lastly, form a conductive layer on the dielectric layer of every cathodic region, thus defining a solid electrolytic capacitor unit.

6 Claims, 7 Drawing Sheets

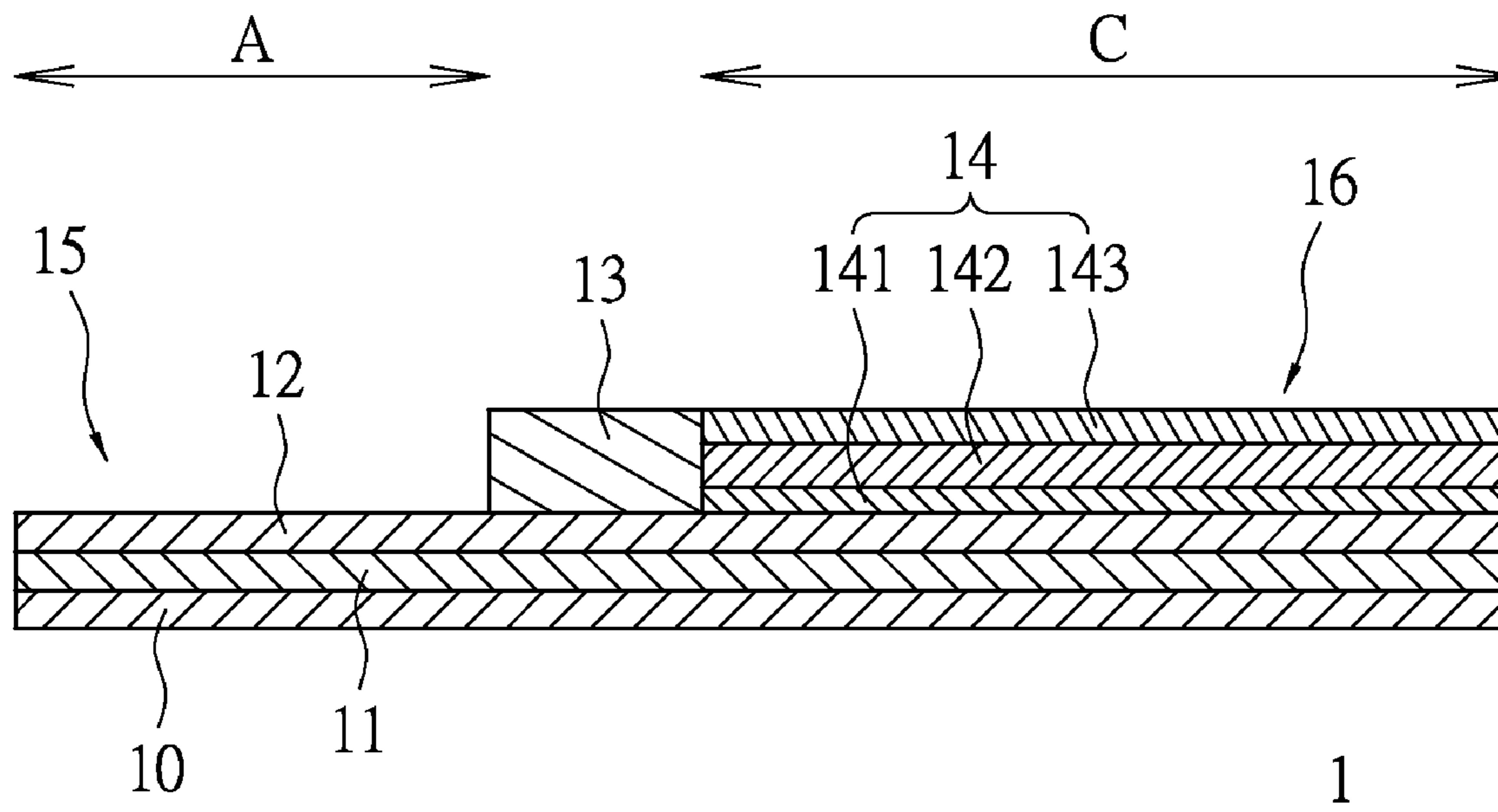

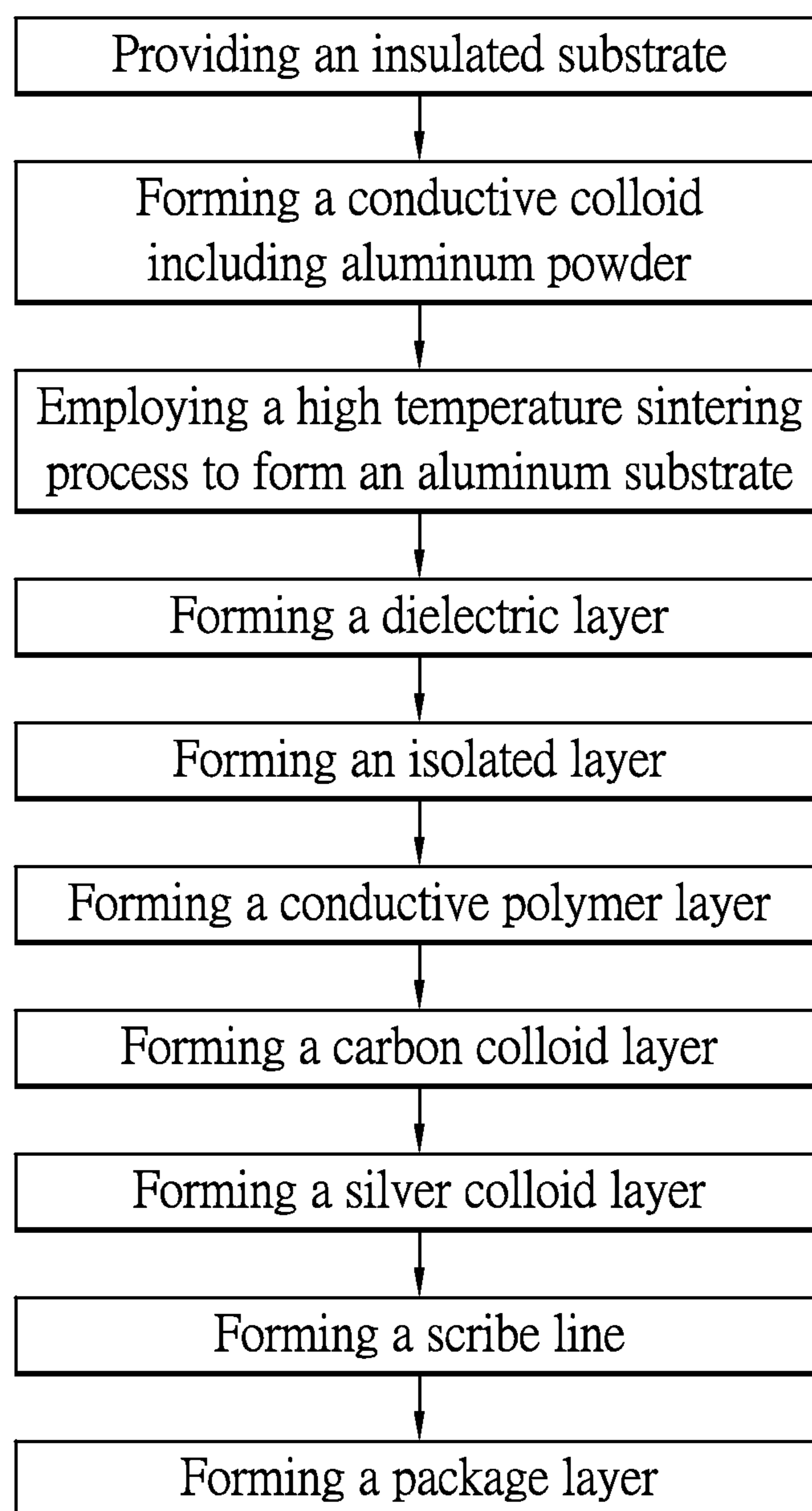

FIG.1

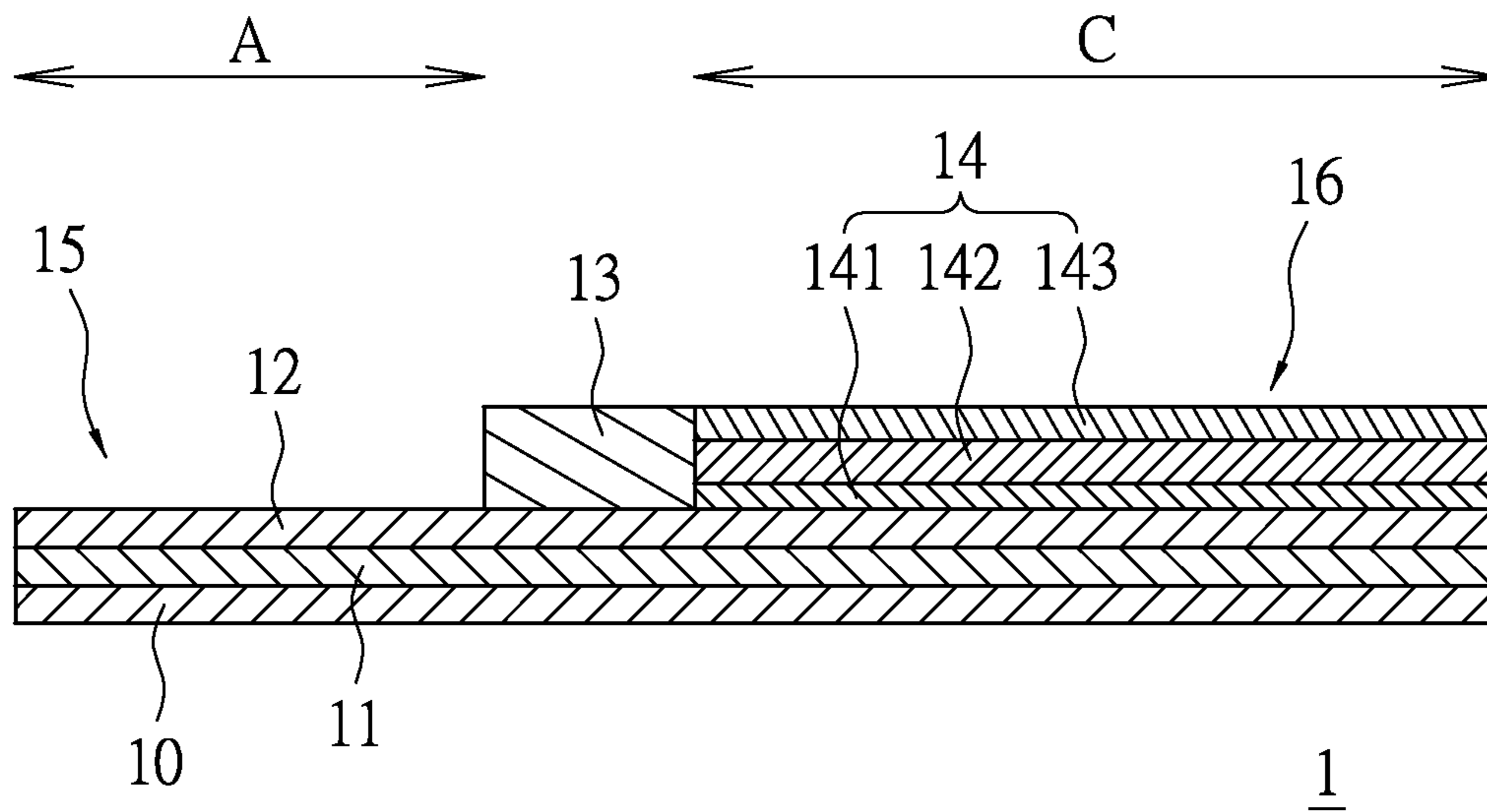

FIG.2

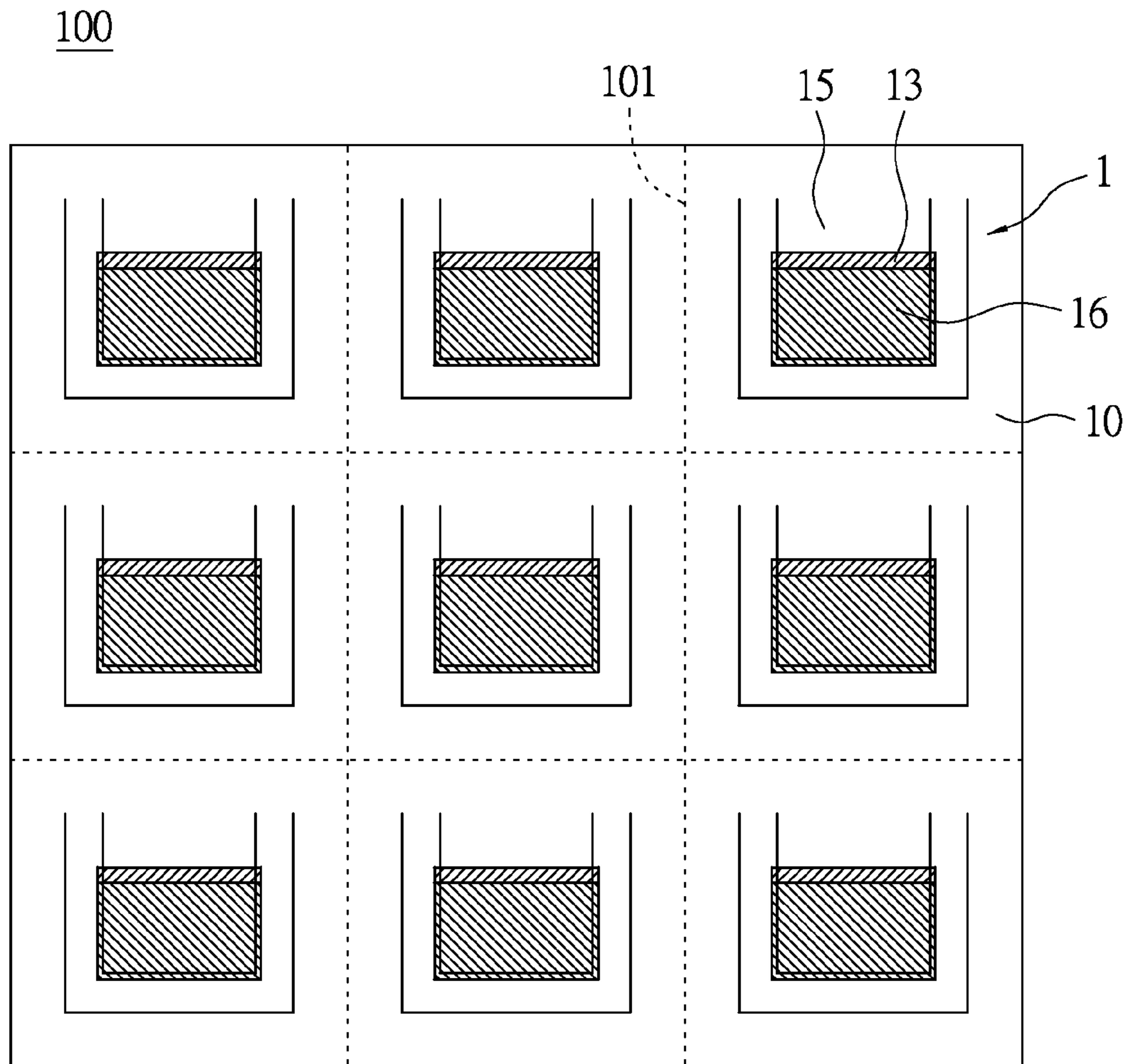

FIG.3

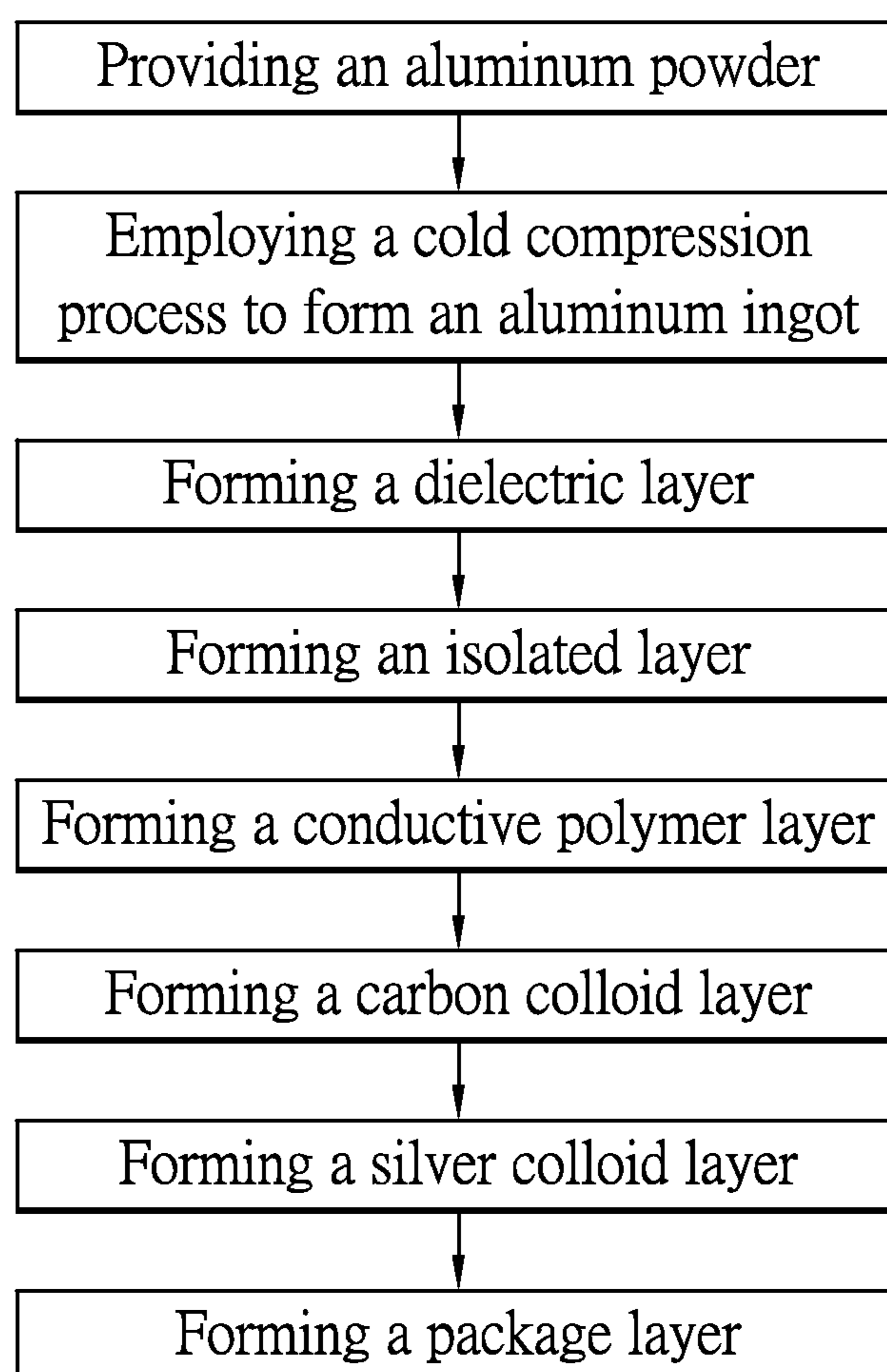

FIG.4

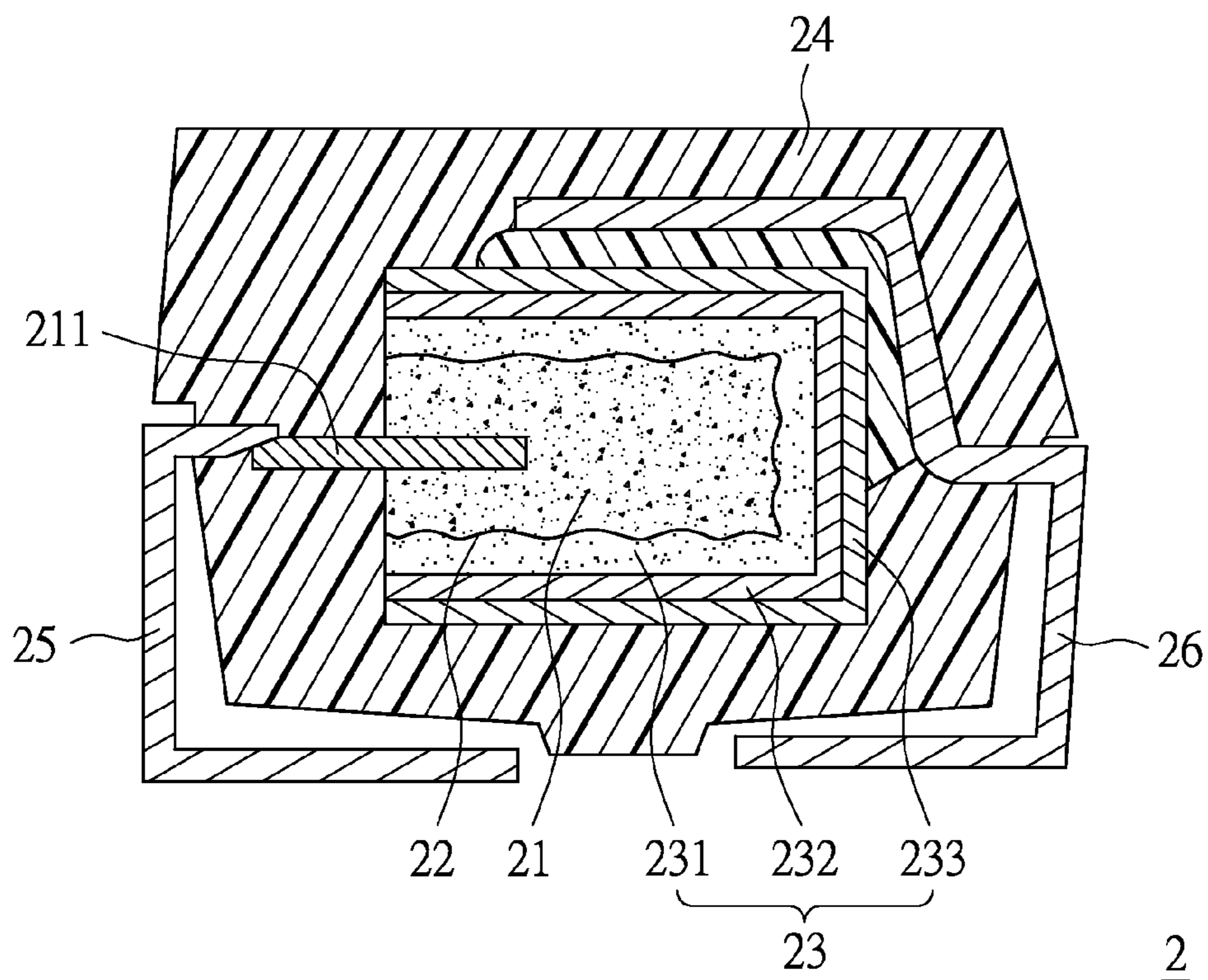

FIG.5

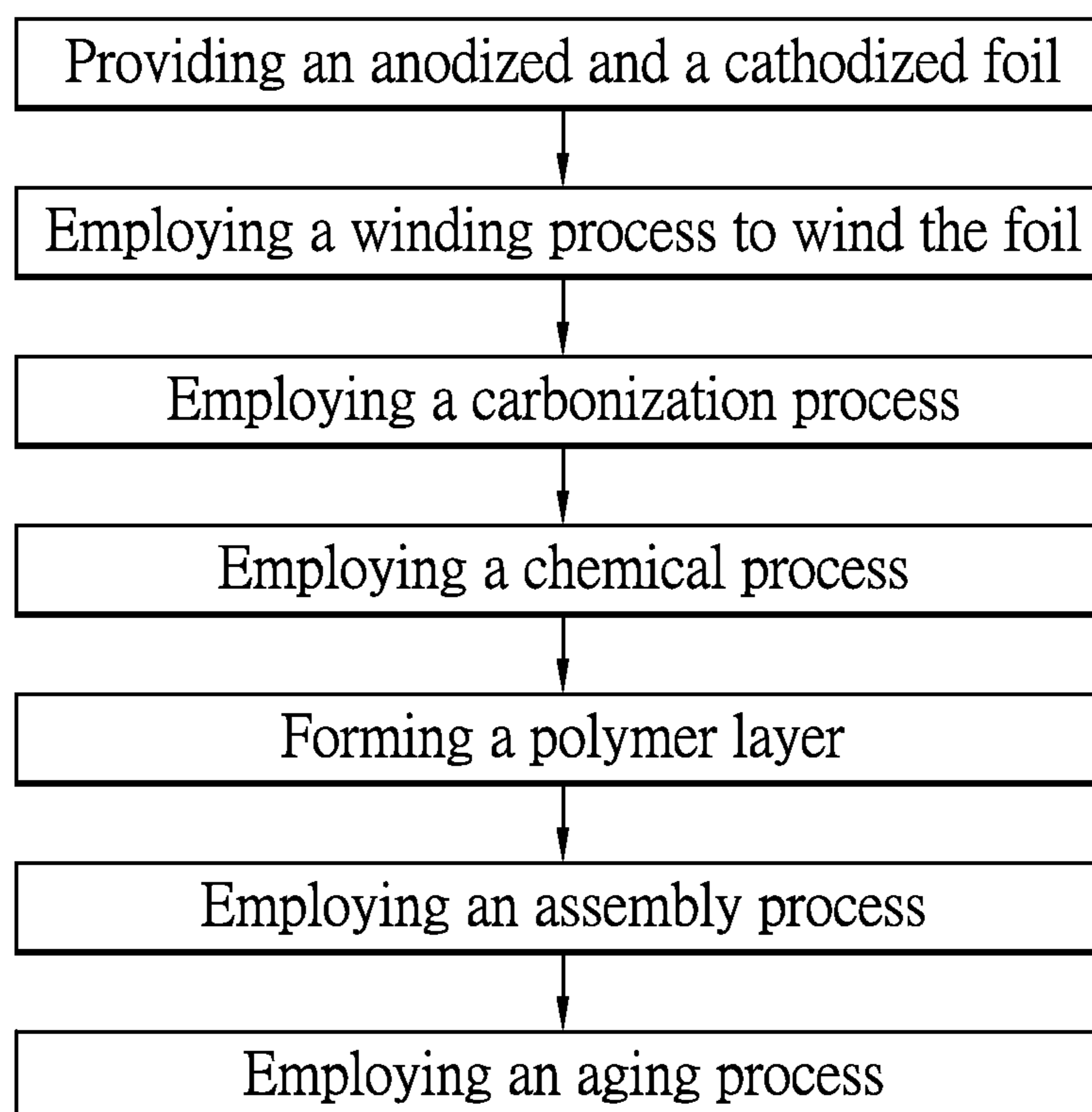

FIG.6

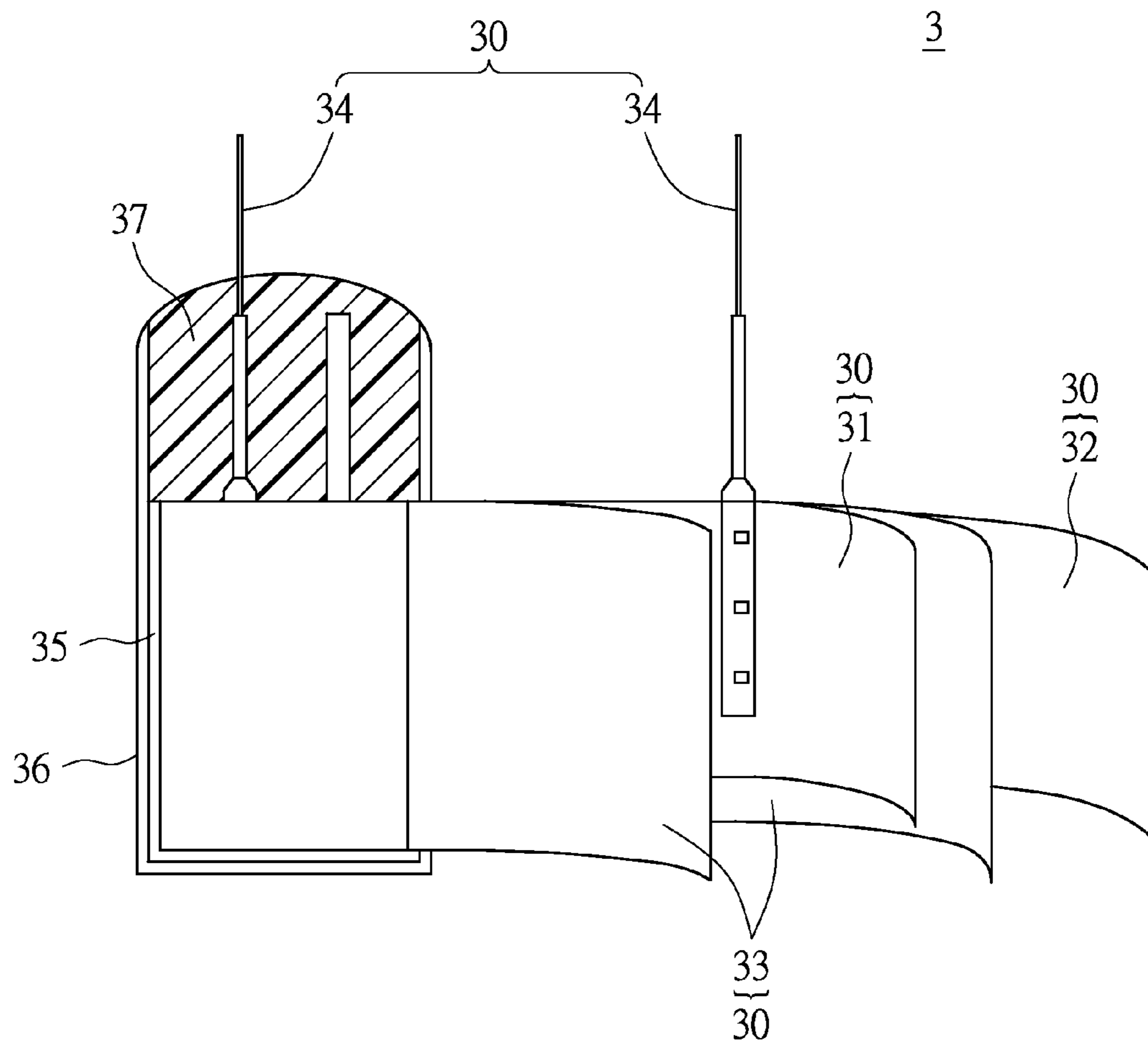

FIG. 7

1

**METHOD FOR FABRICATING SOLID
ELECTROLYTIC CAPACITORS**

BACKGROUND OF THE INVENTION

1. Field of the Invention

The instant disclosure relates to a method for fabricating solid electrolytic capacitors; in particular, a method for improving fabrication of solid electrolytic capacitors.

2. Description of Related Art

As technology rapidly evolves in the semiconductor industry, the demand for products requiring the use of semiconductors as well as the development of a more advanced, sophisticated electronic components become increasingly high. Semiconductor technologies such as flip chip packaging technology, laminated substrate design, and passive components design have an indispensable position in the semiconductor industry.

Take flip chip or ball grid array package structure for example, chips are configured on and electrically connected to the surface of the packaging substrate which is aggregated and formed from multiple layers of patterned circuits, and insulating layers. The patterned circuits are made by etching via photolithography while an insulating layer is disposed between two neighboring patterned circuits. Furthermore, in order to obtain the desired electrical characteristics for the package substrate, the substrate is further arranged with passive components such as capacitors, inductors and resistors which may be electrically connected to the chips and other electronic components through internal wiring of the substrate.

Among passive components, capacitors are classified according to the type of electrolyte applied, and can generally be categorized into liquid electrolytic capacitors and solid electrolytic capacitors. While the life span of the former is determined by the drying time of the liquid electrolyte, the latter uses a solid electrolyte, therefore eliminating the danger of drying electrolyte and providing a longer capacitor life span.

Traditional surface mounted tantalum solid capacitors usually comprise anode elements made from tantalum powder. However, the tantalum powder in the anode element leads to a relatively high technical threshold. For example: in order to increase overall capacitance, small particle size is essential to increase the overall reactive surface and consequently, the capacitance.

However, smaller particle size of the tantalum powder requires additional processing efforts to achieve. Thus, the smaller the particle size is required, the more processing is required to produce the desired size, and as a result, increases the costs. In addition, tantalum particles of smaller size make permeation of the cathode agent more difficult. Furthermore, since only after high-temperature sintering will the tantalum powder be able to form the tantalum sintered bodies on a substrate, the high-temperature sintering process required in the fabrication of traditional surface mounted solid capacitor renders the entire fabrication process more complex.

Additionally, prior art illustrates a multi-layer micro-capacitor comprising a stacked structure of multiple metal layers and dielectric layers, thus facilitating the miniaturization of capacitors, thereby increasing the scope of applications. However, such a structure comes with a higher cost, a high probability of short-circuiting, and a plurality of complex processes during fabrication and assembly.

2

To address the above issues, the inventor strives via associated experience and research to present the instant disclosure, which can effectively improve the limitation described above.

SUMMARY OF THE INVENTION

In order to simplify the complexity of the process, reduce manufacturing costs, and obtain a high yield of the solid electrolyte capacitor, the instant disclosure provides a method for improving fabrication of a solid electrolytic capacitor. According to the first embodiment of the instant disclosure, the method includes an insulating substrate having formed a plurality of aluminum powder containing conductive gel bodies. The conductive gel bodies are arranged in a matrix formation, wherein a scribe line is defined between every two adjacent conductive gels. Thereafter, a high-temperature sintering process is applied on the conductive gel to form a complex aluminum substrate. Next, a dielectric layer is formed at the surface of each of the aluminum substrate, and then an isolation layer is formed at each of the dielectric layer to define an anodic region and a cathodic region. Successively, on each of the cathodic region, an electrically conductive layer is formed on the surface of the dielectric layer resulting in a solid electrolytic capacitor unit.

According to a second embodiment, the improved method includes an aluminum powder being cold compressed to form an aluminum pellet, followed by coating the surface of the aluminum pellet with a dielectric layer, and successively coating a conductive layer on the surface of the dielectric layer.

In summary, one of the embodiments of the instant disclosure, the conductive gel including aluminum powder is formed on the insulating substrate by partial screen printing, and then the conductive gel is sintered to form the aluminum substrate. As a result, one skilled in the art can accurately control the thickness and size of the aluminum substrate, enhances the yield of the capacitor, and can also effectively simplify the complexity of the manufacturing process. Thus, reducing manufacturing costs and process time. In the second embodiment, aluminum pellets are formed by cold compressing an aluminum powder without a high-temperature sintering process resulting in an anode element with higher structural strength. Consequently, with such simplified manufacturing process, the complexity, cost, and process time of the capacitor fabrication are greatly reduced.

In order to further understand the instant disclosure, the following embodiments and illustrations are provided. However, the detailed description and drawings are merely illustrative of the disclosure, rather than limiting the scope being defined by the appended claims and equivalents thereof.

BRIEF DESCRIPTION OF THE DRAWINGS

FIG. 1 is a flow chart illustrating a method for improving fabrication of solid electrolytic capacitors according to a first embodiment of the instant disclosure;

FIG. 2 is a cross-sectional view of a method for improving fabrication of solid electrolytic capacitors according to the first embodiment of the instant disclosure;

FIG. 3 is a top view of a method for improving fabrication of solid electrolytic capacitors according to the first embodiment of the instant disclosure;

FIG. 4 is a flow chart illustrating a method for improving fabrication of solid electrolytic capacitors according to a second embodiment of the instant disclosure;

3

FIG. 5 is a cross-sectional view of a method for improving fabrication of solid electrolytic capacitors according to the second embodiment of the instant disclosure;

FIG. 6 is a flow chart illustrating a method for improving fabrication of solid electrolytic capacitors according to a third embodiment of the instant disclosure; and

FIG. 7 is a cross-sectional view of a method for improving fabrication of solid electrolytic capacitors according to the third embodiment of the instant disclosure.

DETAILED DESCRIPTION OF THE PREFERRED EMBODIMENTS

The instant disclosure is a method for improving fabrication of the solid electrolytic capacitors especially suitable for the manufacturing of chips. Replacement of tantalum powder with aluminum powder further improves the problem encountered during the fabrication of the tantalum capacitors, and simplifies the fabrication of the multi-layer capacitor

First Embodiment

FIG. 1 is a flow chart for a first embodiment of the method, and in conjunction with FIGS. 2 and 3, the method is further explained in details.

Initially, an insulating substrate **10**, preferably an aluminum oxide (Al_2O_3) substrate, is provided.

Next, a conductive gel (not shown in figures) including aluminum powder is formed, preferably formed by a thermosetting resin containing from about 0 wt % to about 50 wt %, a powder of aluminum containing from about 30 wt % to about 100 wt %, and a curing agent containing from about 0 wt % to about 50 wt %. The thermosetting resin is preferably an epoxy resin but is not limited thereto. Moreover, to improve conductivity, the particle size of the aluminum powder ranges from 0.05 to 5 microns. The aluminum powder can be pre-treated in order to provide uneven surfaces for obtaining more surface areas. The most suitable curing agent is preferred to be latent curable. Furthermore, the conductive gel may contain inorganic filler from about 0 wt % to about 50 wt % to reduce linear expansion. Examples of inorganic fillers contemplated for use in the conductive gel are silica, aluminum oxide, or aluminum hydroxide. The conductive gel can be formed on the insulating substrate **10** via techniques such as printing, spray-coating, or similar fashion, and is arranged in a matrix arrangement. Between every two adjacent conductive gels, a scribe line **101** is defined therebetween for facilitating substrate cutting in the process thereafter. Preferably, the conductive gel is formed on the insulating substrate **10** via partial screen printing for the precise control of length and thickness of the conductive gel formed, thus reduces fabrication cost and process time.

As the conductive gel is cured (metalized) on the insulating substrate **10**, a complex aluminum substrate **11** (a sintered body of the conductive gel) is formed on the insulating substrate via a high temperature sintering process. Preferably, the temperature and the time of the high temperature sintering process ranges from 300° C. to 550° C., and from 0.5 hour to 1.5 hours, respectively.

Moreover, the insulating substrate **10** and the aluminum substrate **11** are chemically treated, preferably anodized in the instant embodiment, to form an oxidized film, preferably an insulating alumina spacer, onto the surface of the insulating substrate **11**, thus forming a dielectric layer **12**. Furthermore, the chemical treatment may also use electrochemical formation or chemical solution to control the thickness of the dielectric layer **12** being formed. The dielectric layer **12** of the

4

first embodiment is produced by an ammonium adipate based, a phosphoric acid based or the combination solution thereof. An alternative to the chemical treatment of the first embodiment is to immerse the insulating substrate **10** and the aluminum substrate **11** into an electrolyte bath for cross oxidation, heat treating and therefore producing a dense dielectric layer **12**, preferably an oxidized film.

Furthermore, an isolation layer **13** such as an insulating resin is formed on the center surface of the dielectric layer **12** for isolating an anode capacitance **15** from a cathode capacitance **16** arranged on two opposite sides of the isolation layer **13**, thus defining an anodic region A and a cathodic region C on the insulating substrate **10**.

In addition, a conductive layer **14** including a conductive polymer layer **141**, a carbon gel layer **142**, and a silver gel layer **143** preferably arranged in the cathodic region C is formed on the surface of the dielectric layer **12**. Specifically, the conductive polymer layer **141** is first formed on the dielectric layer **12**, then the carbon gel layer **142** is formed on the conductive polymer layer **141**, and sequentially the silver gel layer **143** is formed on the carbon gel layer **142** resulting in the conductive layer **14** and the cathode capacitance **16**. The aluminum substrate **11** covered by the dielectric layer **12** and oppositely arranged from the cathode capacitance **16** of the isolation layer **13** is the anode capacitance **15**. As a result, a solid electrolytic capacitor unit **100** is fabricated.

Moreover, the conductive polymer layer **141** is formed as a film by evenly coating a conductive polymer solution onto the surface of the dielectric layer **12** through a field-effect controlled precision coating technique, thus providing solid electrolytic qualities. The preferred conductive polymer maybe polyaniline, polypyrrole or polythiophen while the most preferred conductive polymer layer **141** is polyaniline. The composition of the conductive polymer solution includes anilines, oxidants and dopants. The carbon gel layer **142** can be formed by conductive gel, carbon paste. However, the form of the carbon gel layer **142** is not limited to the samples of the embodiment provided therein.

Furthermore, the solid electrolytic capacitor unit **100** is cut into a plurality of solid electrolytic capacitors **1** by precisely cutting the insulating substrate **10** conformingly along the scribe lines **101**.

Successively, the anode capacitance **15** and the cathode capacitance **16** are separately arranged on a lead frame of a supporting member (not shown) to form two opposing electrodes. The solid electrolytic capacitor **1** is covered with coating materials such as heat and electrically insulating resins, then cured and aged to form a package structure and facilitate soldering the package structure onto circuit boards via surface-mount technology (SMT)

Second Embodiment

FIG. 4 is a flow chart and in conjunction with FIG. 5 illustrate a second embodiment for the method. Foremost, a powder of aluminum is provided. The aluminum powder may contain a binder such as camphor, stearic acid, polyvinyl alcohol, or naphthalene. The preferred aluminum powder is formed with the binder while the preferred weight percent of the binder ranges from 3 to 5%.

Next, a thoroughly mixed aluminum powder and binder mixture is cold compressed into a plurality of rectangular parallelepiped aluminum pellets **21** with a compression molding process. Preferably, the cold press load ranges from 3 to 15 MN/m² to provide the desired bulk density. In addition, a lead electrode **211** is inserted within the aluminum powder in a cantilever fashion during the cold press process

for mutually communicating electricity. The preferred lead electrode **211** is an aluminum or a tantalum wire but not limited to the examples provided therein. The preferred lead electrode **211** in the second embodiment is a 20 μm aluminum wire to further reduce thickness of components in a capacitor but not limited to examples provided therein. Moreover, the preferred capacitor fabricated has high capacitance or low leakage rate. By etching the aluminum powder unevenly and cavernously on the surface before the cold press process, the surface area of the aluminum powder is increased, thus providing improved capacitance.

The compressed aluminum pellet **21** is further chemically treated, specifically anodized, to form an oxide coating, specifically an insulating aluminum oxide film, on the surface of the pellet **21**, thereby forming a dielectric layer **22**. Similar to the first embodiment, the chemical treatment may also use electrochemical formation treatment or chemical solution to control the thickness of the dielectric layer **22** being formed. The dielectric layer **22** of the second embodiment is produced by an ammonium adipate based, a phosphoric acid based or the combination solution thereof. An alternative to the chemical treatment of the second embodiment is to immerse the aluminum pellet **21** into an electrolyte bath for cross oxidation, heat treating and therefore producing a dense dielectric layer **22**, specifically an oxidized film.

A conductive polymer layer **231** is formed on the surface of the dielectric layer **22**, then a carbon gel layer **232** is formed on the surface of the conductive polymer layer **231**, and a silver gel layer **233** is formed on the surface of the carbon gel layer **232** resulting in a cathode (not marked). Similar to the first embodiment, the aluminum pellet **21** of the second embodiment is formed with a lead electrode **211** extruding therefrom in a cantilever fashion and resulting in an anode (not marked). As a result, a conductive layer **23** is formed.

The lead electrode **211** and the conductive layer **23** are separately and electrically connected to a conductive terminal such as an anode **25** and a cathode **26** through a conductive bonding agent. Successively, the lead electrode **211**, the conductive layer **23**, part of the anode **25** and cathode **26** are covered by a resin-type coating, cured, and aged to form a packaging structure **24**, thereby fabricating a solid electrolytic capacitor **2** of the second embodiment.

A flow chart in FIG. **6** and FIG. **7** illustrate the third embodiment of the method in the instant disclosure. Initially, a powder of aluminum is sprayed onto a sheet of aluminum and dried through a high temperature sintering process resulting with a porous aluminum sintered body. An oxide film is then formed by oxidation on the sintered body resulting with an anodized foil **31**. In addition, a cathodized foil **32** is also formed. Please refer to the first embodiment for the preferred time and temperature of the high temperature sintering process. The aluminum powder may also include titanium or hydride based sintering agent as the raw aluminum powder. Moreover, preferred examples of the cathodized foil **32** may contain carbon, aluminum, and titanium but are not limited to the examples provided therein.

Next, a preferred spacer **33** or a thin sheet of suitable materials such as Manila hemp fiber electrolytic paper and a lead electrode **34** are wound between the anodized foil **31** and the cathodized foil **32** to form a capacitor core **30**. The preferred spacer **33** material is Manila hemp fiber electrolytic paper but is not limited to the example provided herein. The preferred thickness of the spacer **33** is from 30 to 60 μm while the preferred density is from 0.2 to 0.6 g/cm^3 .

Moreover, the capacitor core **30** is carbonized or similar carbonization techniques at a preferred temperature ranging from 200° C. to 300° C. Sequentially, the capacitor core **30** is

immersed into an electrolyte bath to form a dielectric layer. Consecutively, the capacitor core **30** is dipped into a polymer solution, and heat treated to cure after removed from the solution to form a polymer layer **35** with preferably high conductivity.

The capacitor core **30** is housed by an aluminum cover **36**. Then an epoxy resin, a butyl rubber or a preferably suitable sealant packages and seals the capacitor core **30** and an aluminum cover **36** therein while exposing the lead electrode **34**, thus resulting in a package structure **37**.

Successively, the package structure **37** is cured and aged to form a solid electrolytic capacitor **3** of the third embodiment. Temperature and time of the aging process may be adjusted depending on the type, capacity, and voltage of the capacitor.

In summary, the first embodiment illustrates the conductive gel containing aluminum powder partially screen-printed onto the insulating substrate **10**, and subsequently high temperature sintering the insulating substrate **10** to form the aluminum substrate **11**. As a result, the fabrication process is simplified, production time is reduced, and the yield of capacitor is improved through precisely controlling the thickness and length of the aluminum substrate **11**. In the second embodiment of the instant disclosure differs from the first embodiment in terms of the form of aluminum and technique to fabricate the capacitor, wherein the aluminum powder is cold compressed to form an aluminum pellet **21** instead of high temperature sintering. Furthermore, the aluminum powder maybe pre-treated to obtain higher surface area to increase capacitance of the capacitor while aluminum powder replaces tantalum powder to resolve problems generated during the production of tantalum based capacitors. The three embodiments of the instant disclosure effectively simplify the fabrication of the solid electrolytic capacitors through altering the physical and chemical characteristics of aluminum powder.

The aforementioned illustrations and detailed descriptions are exemplarities for the purpose of further explaining the scope of the instant disclosure. Other objectives and advantages related to the instant disclosure will be illustrated in the subsequent descriptions and appended drawings.

What is claimed is:

1. A method for improving fabrication of solid electrolytic capacitors comprising the steps of:

- providing an insulating substrate;
- forming a plurality of aluminum powder containing conductive gel bodies on the insulating substrate, wherein two adjacent conductive gel bodies define a scribe line therebetween;
- employing a high temperature sintering process to metalize the conductive gel bodies into a plurality of aluminum substrates;
- forming a dielectric layer on each of the surface of the aluminum substrate;
- forming an isolation layer on each of the dielectric layer to define an anodic region and a cathodic region; and
- covering the dielectric layer of the cathodic region with a conductive layer.

2. The method as recited in claim **1**, wherein the step of covering the conductive layer includes steps of: forming a conductive polymer layer on the dielectric layer of the cathodic region; forming a carbon gel layer on the conductive polymer layer; and forming a silver gel layer on the carbon gel layer.

3. The method as recited in claim **2**, wherein the carbon gel layer is formed by one of the following: a conductive carbon gel, and a carbon based paste.

4. The method as recited in claim 1, wherein the aluminum powder containing conductive gel bodies comprises:
a thermosetting resin presented from about 0 wt % to about 50 wt %;
a powder of aluminum presented from about 30 wt % to about 100 wt %;
a curing agent presented from about 0 wt % to about 50 wt %; and
an inorganic filler presented from about 0 wt % to about 50 wt %.

5. The method as recited in claim 4, wherein the particle size of the aluminum powder ranges from 0.05 to 5 μm .

6. The method as recited in claim 1, wherein the conductive gel is formed on the insulating substrate via partial screen printing and the temperature and the time of the high temperature sintering process ranges from 300° C. to 550° C., and from 0.5 hour to 1.5 hours, respectively.

* * * * *