



US009114354B2

(12) **United States Patent**  
**Ball et al.**

(10) **Patent No.:** **US 9,114,354 B2**  
(45) **Date of Patent:** **Aug. 25, 2015**

(54) **HEAT TRANSFER DEVICE FOR WATER RECOVERY SYSTEM**

(71) Applicant: **Z124**, George Town (KY)  
(72) Inventors: **James Ball**, Hamilton (CA); **Charles Becze**, Oakville (CA); **Michael J. Flynn**, Burlington (CA); **Kean Wing Kin Lam**, Richmond Hill (CA); **Richard Teltz**, Hamilton (CA)

(73) Assignee: **Z124**, George Town (KY)

(\*) Notice: Subject to any disclaimer, the term of this patent is extended or adjusted under 35 U.S.C. 154(b) by 198 days.

(21) Appl. No.: **13/660,620**

(22) Filed: **Oct. 25, 2012**

(65) **Prior Publication Data**

US 2013/0319233 A1 Dec. 5, 2013

**Related U.S. Application Data**

(60) Provisional application No. 61/655,316, filed on Jun. 4, 2012.

(51) **Int. Cl.**  
**B01D 53/02** (2006.01)  
**B01D 53/26** (2006.01)  
(Continued)

(52) **U.S. Cl.**  
CPC ..... **B01D 53/263** (2013.01); **B01D 53/0454** (2013.01); **B01D 53/18** (2013.01);  
(Continued)

(58) **Field of Classification Search**  
CPC .... B01D 53/0454; B01D 53/18; B01D 53/26;  
B01D 53/263; B01D 53/28; F24F 3/1417;  
F25B 17/02; F25B 37/00; F25B 43/00;  
F25D 21/14; Y02B 30/62; Y02B 60/50;  
Y10T 29/49396; Y10T 29/49826  
See application file for complete search history.

(56) **References Cited**

U.S. PATENT DOCUMENTS

1,772,089 A 8/1930 Smith  
2,026,935 A 1/1936 Downs

(Continued)

FOREIGN PATENT DOCUMENTS

GB 513562 10/1939  
GB 518473 2/1940

OTHER PUBLICATIONS

Website "Co-Generation," E. Power Generation, Marlow Industries, Inc., 2012, 1 page, retrieved from [www.marlow.com/resources/knowledgebase/ii-tem-primary-uses/e-power-generation/co-generation.html](http://www.marlow.com/resources/knowledgebase/ii-tem-primary-uses/e-power-generation/co-generation.html).

(Continued)

*Primary Examiner* — Christopher P Jones

(74) *Attorney, Agent, or Firm* — Sheridan Ross P.C.

(57) **ABSTRACT**

A system and method to recover water from an ambient airstream. Dehumidification of the airstream is also achieved by removal of the water. A device of the system includes a chamber having a group of trays that hold respective amounts of liquid desiccant in each tray. A foam media absorbs the desiccant to increase an exposed surface of the desiccant to the airstream. Fans and valves are used to control airflow through the device. A charge cycle circulates air through the device to remove water vapor from the airstream. A subsequent extraction cycle removes water collected in the liquid desiccant by a condenser communicating with the chamber. A heat source adds heat to the chamber before and/or during the extraction cycle. A controller is used to integrate and manage all system functions and input variables to achieve a high efficiency of operational energy use for water collection.

**18 Claims, 13 Drawing Sheets**

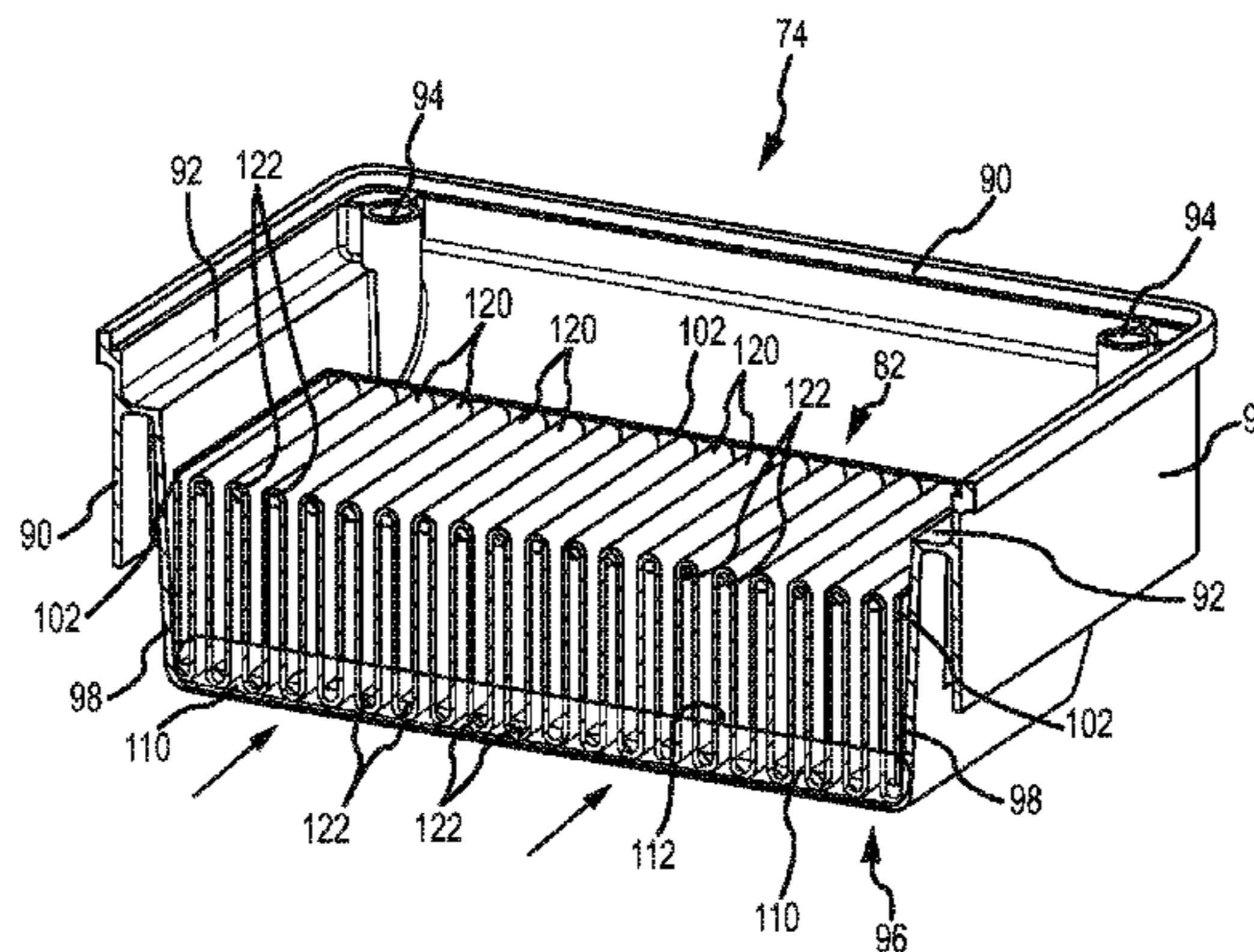



- (51) **Int. Cl.**  
*F25B 17/02* (2006.01)  
*F25D 21/14* (2006.01)  
*F24F 3/14* (2006.01)  
*F25B 43/00* (2006.01)  
*B01D 53/18* (2006.01)  
*B01D 53/04* (2006.01)  
*B01D 53/28* (2006.01)  
*F25B 37/00* (2006.01)

- 2012/0176078 A1 7/2012 English et al.  
 2012/0176978 A1 7/2012 Kim  
 2012/0199211 A1 8/2012 Schroder et al.  
 2013/0319244 A1 12/2013 Ball et al.

OTHER PUBLICATIONS

Website “Direct Generation,” E. Power Generation, Marlow Industries, Inc., 2012, 1 page, retrieved from [www.marlow.com/resources/knowledgebase/ii-tem-primary-uses/e-power-generation/direct-generation.html](http://www.marlow.com/resources/knowledgebase/ii-tem-primary-uses/e-power-generation/direct-generation.html).

Website “Energy Harvesting,” E. Power Generation, Marlow Industries, Inc., 2012, 1 page, retrieved from [www.marlow.com/resources/knowledgebase/ii-tem-primary-uses/e-power-generation/energy-harvesting.html](http://www.marlow.com/resources/knowledgebase/ii-tem-primary-uses/e-power-generation/energy-harvesting.html).

Website “Waste Heat Recovery,” E. Power Generation, Marlow Industries, Inc., 2012, 1 page, retrieved from [www.marlow.com/resources/knowledgebase/ii-tem-primary-uses/e-power-generation/waste-heat-recovery.html](http://www.marlow.com/resources/knowledgebase/ii-tem-primary-uses/e-power-generation/waste-heat-recovery.html).

Venkatasubramanian, “Efficient Thermoelectric Power Conversion of Waste Heat for Deployed Forces (EW-1651),” SERDP, Arlington, VA, 2012, 3 pages, retrieved from [www.serdp.org/content/view/pdf/6791](http://www.serdp.org/content/view/pdf/6791).

Notice of Allowance for U.S. Appl. No. 13/908,576 mailed Jun. 30, 2014, 8 pages.

Corrected Notice of Allowance for U.S. Appl. No. 13/713,972, mailed Aug. 1, 2014 4 pages.

Official Action for U.S. Appl. No. 13/660,572 mailed Jun. 26, 2014, 8 pages.

Official Action for U.S. Appl. No. 13/693,451 mailed Aug. 19, 2014, 5 pages.

Hung et al. “Integration of Desiccant tray unit with internal cooling for aeration of paddy silo in humid tropical climate,” Biosystems Engineering, Jan. 2009, vol. 102, No. 1, pp. 75-82.

International Search Report and Written Opinion for International (PCT) Patent Application No. PCT/IB2013/001858, mailed Dec. 4, 2013 4 pages.

Notice of Allowance for U.S. Appl. No. 13/660,499, mailed May 9, 2014 11 pages.

Notice of Allowance for U.S. Appl. No. 13/713,972, mailed May 21, 2014 11 pages.

Notice of Allowance for U.S. Appl. No. 13/660,525, mailed May 12, 2014 11 pages.

Notice of Allowance for U.S. Appl. No. 13/693,398, mailed May 16, 2014 11 pages.

Notice of Allowance for U.S. Appl. No. 13/660,602, mailed May 14, 2014 11 pages.

Notice of Allowance for U.S. Appl. No. 13/660,639, mailed May 30, 2014 9 pages.

Notice of Allowance for U.S. Appl. No. 13/693,418, mailed May 29, 2014 10 pages.

U.S. Appl. No. 13/660,499, filed Oct. 25, 2012, Ball et al.

U.S. Appl. No. 13/713,972, filed Dec. 13, 2012, Becze et al.

U.S. Appl. No. 13/660,525, filed Oct. 25, 2012, Ball et al.

U.S. Appl. No. 13/714,006, filed Dec. 13, 2012, Becze et al.

U.S. Appl. No. 13/693,398, filed Dec. 4, 2012, Becze et al.

U.S. Appl. No. 13/660,572, filed Oct. 25, 2012, Ball et al.

U.S. Appl. No. 13/660,602, filed Oct. 25, 2012, Ball et al.

U.S. Appl. No. 13/660,639, filed Oct. 25, 2012, Ball et al.

U.S. Appl. No. 13/693,418, filed Dec. 4, 2012, Becze et al.

U.S. Appl. No. 13/693,451, filed Dec. 4, 2012, Becze et al.

U.S. Appl. No. 13/723,113, filed Dec. 20, 2012, Becze et al.

U.S. Appl. No. 13/746,824, filed Mar. 26, 2013, Ball et al.

Website “Waste Heat Recovery Applications,” Cool Energy, 2 pages, Jul. 16, 2012 webarchive, retrieved from ([web/archive.org/web/20120716024750/http://www.coolenergyinc.com/wasteheat.html](http://web.archive.org/web/20120716024750/http://www.coolenergyinc.com/wasteheat.html)).

Website “Waste heat recovery unit,” Wikipedia, modified May 28, 2012, retrieved from ([web/archive.org/web/20120815192859/http://en.wikipedia.org/wiki/Waste\\_heat\\_rec](http://web.archive.org/web/20120815192859/http://en.wikipedia.org/wiki/Waste_heat_rec) . . .).

Bhatia “Desiccant Cooling Technology Resource Guide,” Continuing Education and Development, Inc. Jan. 2000, 115 pages.

- (52) **U.S. Cl.**  
 CPC ..... *B01D 53/26* (2013.01); *B01D 53/28* (2013.01); *F24F 3/1417* (2013.01); *F25B 17/02* (2013.01); *F25B 37/00* (2013.01); *F25B 43/00* (2013.01); *F25D 21/14* (2013.01); *Y02B 30/62* (2013.01); *Y02B 60/50* (2013.01); *Y10T 29/49396* (2015.01); *Y10T 29/49826* (2015.01)

(56) **References Cited**

U.S. PATENT DOCUMENTS

2,804,935	A	9/1957	Hutchinson	
2,804,941	A	9/1957	Hutchinson	
2,995,203	A	8/1961	Maurer	
3,254,473	A	6/1966	Fryar et al.	
3,254,497	A	6/1966	Henry et al.	
3,257,738	A	6/1966	Thomas	
3,288,448	A	11/1966	Patterson et al.	
4,209,364	A	6/1980	Rothschild	
4,330,627	A	5/1982	Thomas et al.	
4,612,447	A	9/1986	Rowe	
4,722,018	A	1/1988	Pohl	
4,842,045	A	6/1989	Reinmuller	
4,971,610	A	11/1990	Henderson	
5,988,283	A	11/1999	Gann	
6,059,934	A	5/2000	Stober et al.	
6,134,903	A	10/2000	Potnis et al.	
6,156,102	A	12/2000	Conrad et al.	
6,216,483	B1	4/2001	Potnis et al.	
6,216,489	B1	4/2001	Potnis et al.	
6,336,957	B1 *	1/2002	Tsymerman	95/115
6,463,891	B2	10/2002	Algrain et al.	
6,536,215	B1	3/2003	Vikstrom	
6,562,303	B1	5/2003	Ragnarsson	
6,641,947	B1	11/2003	Molloy et al.	
6,717,284	B2	4/2004	Lin	
6,729,133	B1	5/2004	Sorter et al.	
6,800,965	B1	10/2004	Turner et al.	
6,823,151	B2	11/2004	Carlson et al.	
6,898,943	B2	5/2005	Tanaka	
6,899,749	B2	5/2005	Johansson	
6,938,683	B2	9/2005	Lin	
6,981,915	B2	1/2006	Moore et al.	
7,157,802	B2	1/2007	Bodkin	
7,228,887	B2	6/2007	Chen et al.	
7,377,958	B2	5/2008	Cunanan	
7,569,194	B2	8/2009	Russell	
7,780,762	B2	8/2010	Blondel et al.	
7,863,839	B2	1/2011	Schuricht et al.	
7,969,029	B2	6/2011	Vitagliano	
8,021,542	B2	9/2011	Kirts	
2001/0015077	A1	8/2001	Potnis et al.	
2002/0005271	A1	1/2002	Weiss et al.	
2004/0031282	A1	2/2004	Kopko	
2006/0156750	A1	7/2006	Lowenstein et al.	
2006/0206996	A1	9/2006	Lumbert	
2006/0257258	A1	11/2006	Zwebner	
2007/0280400	A1	12/2007	Keller	
2009/0133414	A1 *	5/2009	Vetrovec et al.	62/94
2009/0175726	A1	7/2009	Rosati et al.	
2010/0083530	A1	4/2010	Weisselberg et al.	
2011/0138832	A1	6/2011	Al-Hadhrami et al.	
2011/0220729	A1	9/2011	Bucknell	
2011/0232485	A1	9/2011	Ellsworth	
2011/0283118	A1	11/2011	Maniktala	

(56)

**References Cited**

OTHER PUBLICATIONS

Callier "Military Aircraft May Produce Electricity from Waste Heat," RenewableEnergyWorld.com, Oct. 15, 2009, 1 page, found at ([www.renewableenergyworld.com/rea/news/article/2009/10/the-future-of-electricity-may-be-found-in-environmentally-friendly-thermoelectric-cells](http://www.renewableenergyworld.com/rea/news/article/2009/10/the-future-of-electricity-may-be-found-in-environmentally-friendly-thermoelectric-cells)).

International Preliminary Report on Patentability for International Patent Application No. PCT/IB2013/001858, mailed Dec. 18, 2014 8 pages.

Notice of Allowance for U.S. Appl. No. 13/714,006, mailed Dec. 19, 2014 5 pages.

Notice of Allowance for U.S. Appl. No. 13/660,572, mailed Dec. 4, 2014, 5 pages.

Notice of Allowance for U.S. Appl. No. 13/693,451, mailed Jan. 13, 2015, 9 pages.

Restriction Requirement for U.S. Appl. No. 13/723,113, mailed Nov. 12, 2014, 12 pages.

Notice of Allowance for U.S. Appl. No. 13/723,113, mailed Jan. 27, 2015, 14 pages.

Official Action for U.S. Appl. No. 13/746,824, mailed Jan. 21, 2015, 7 pages.

\* cited by examiner



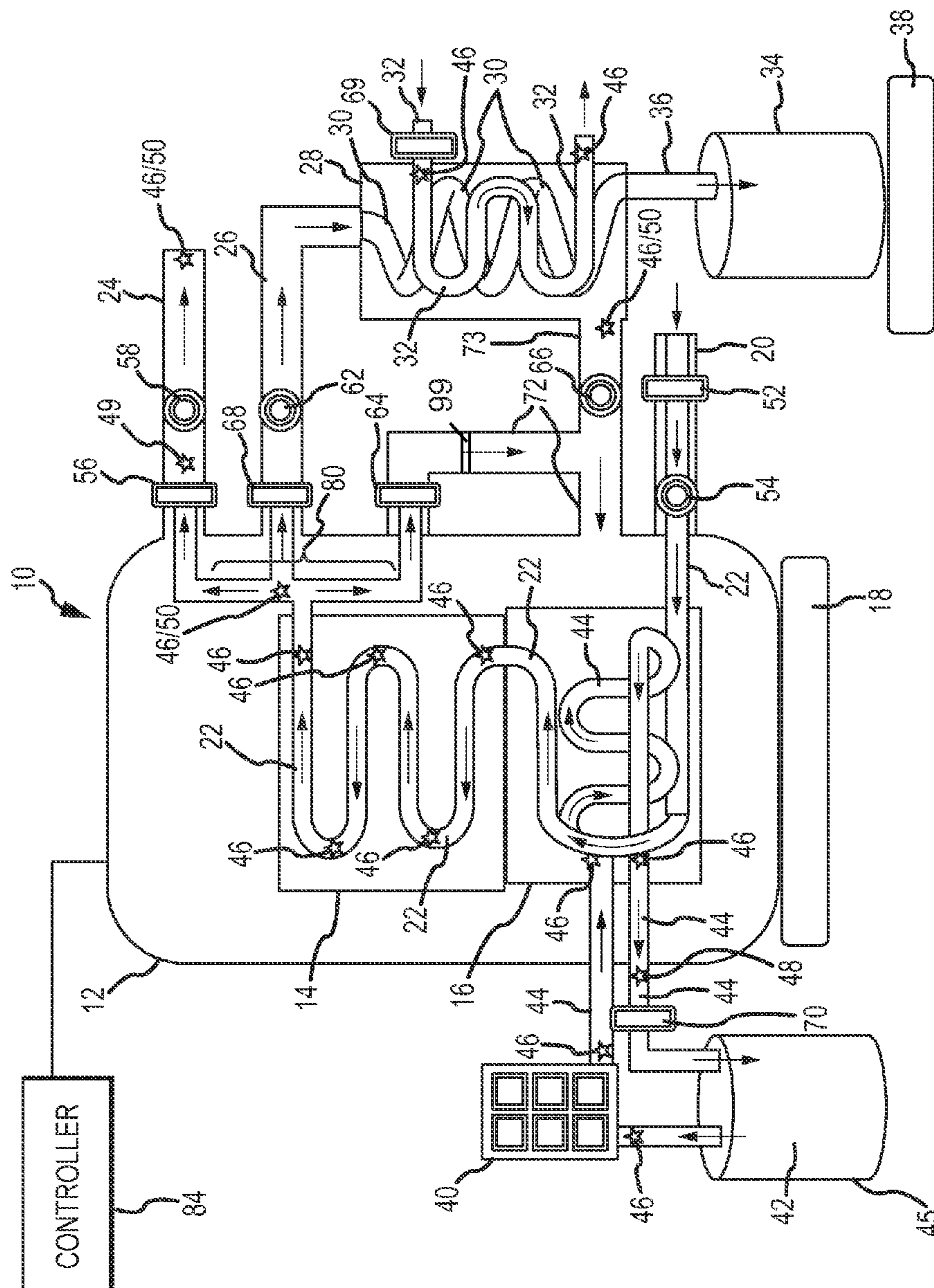

FIG. 1

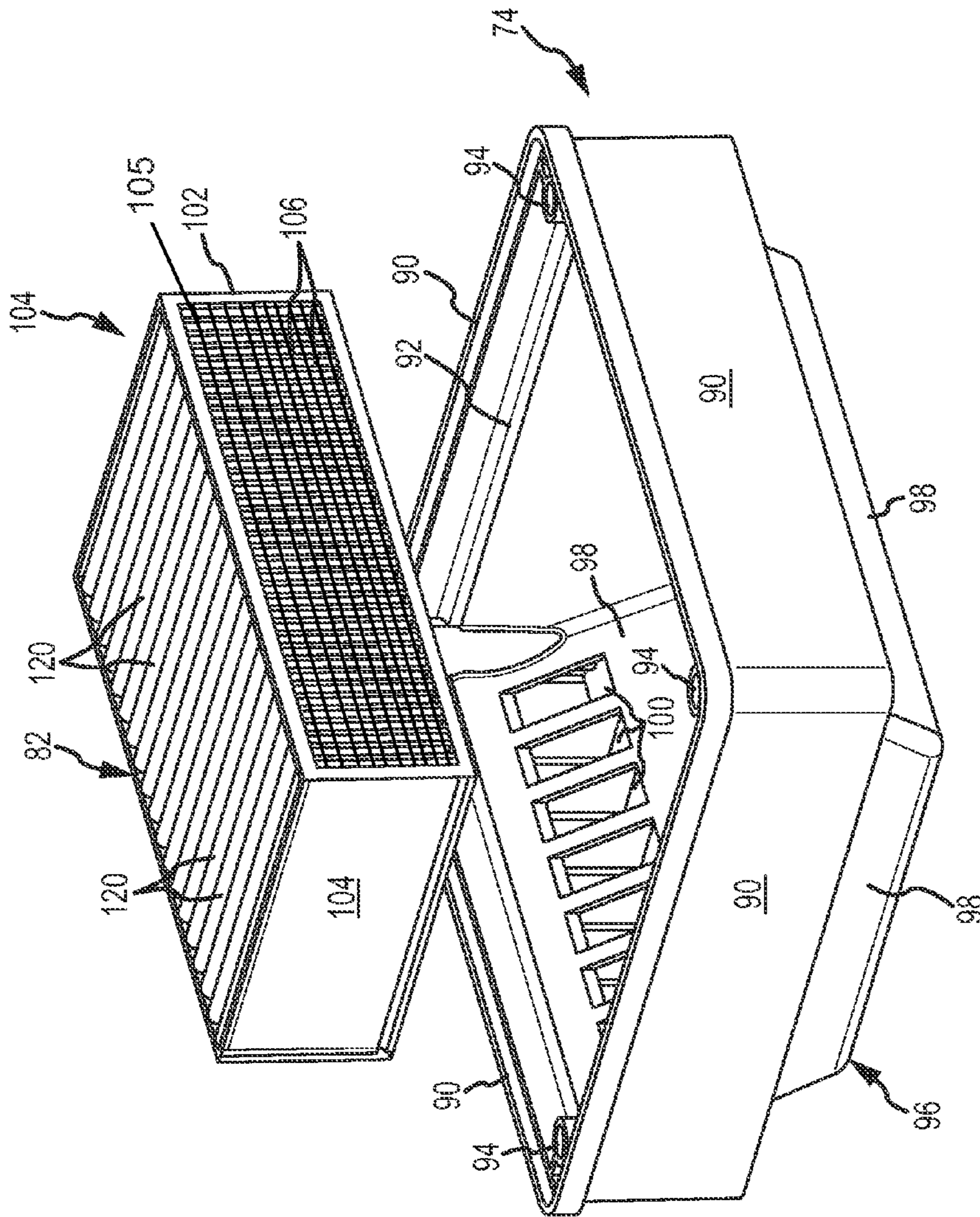

FIG. 2

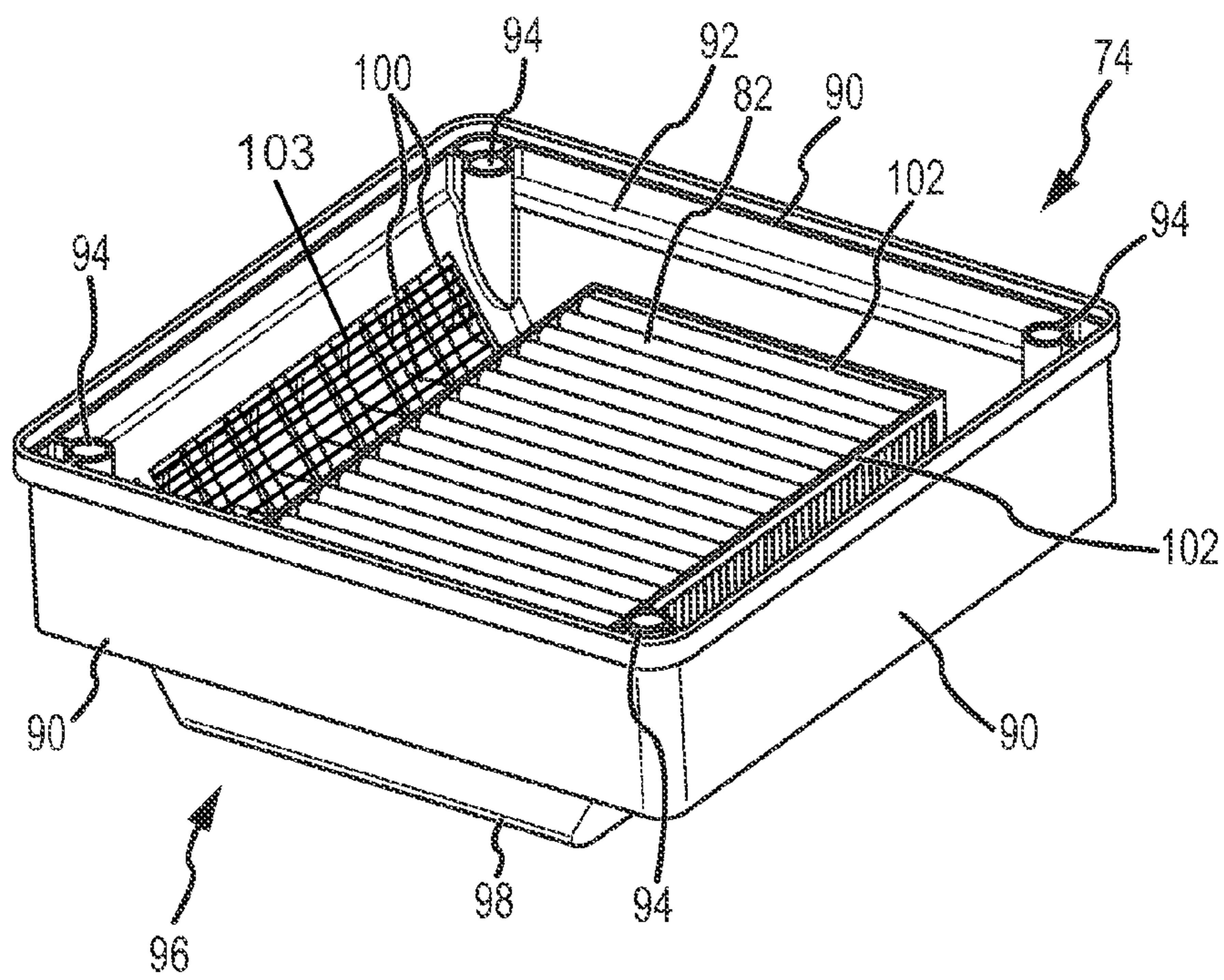

FIG.3



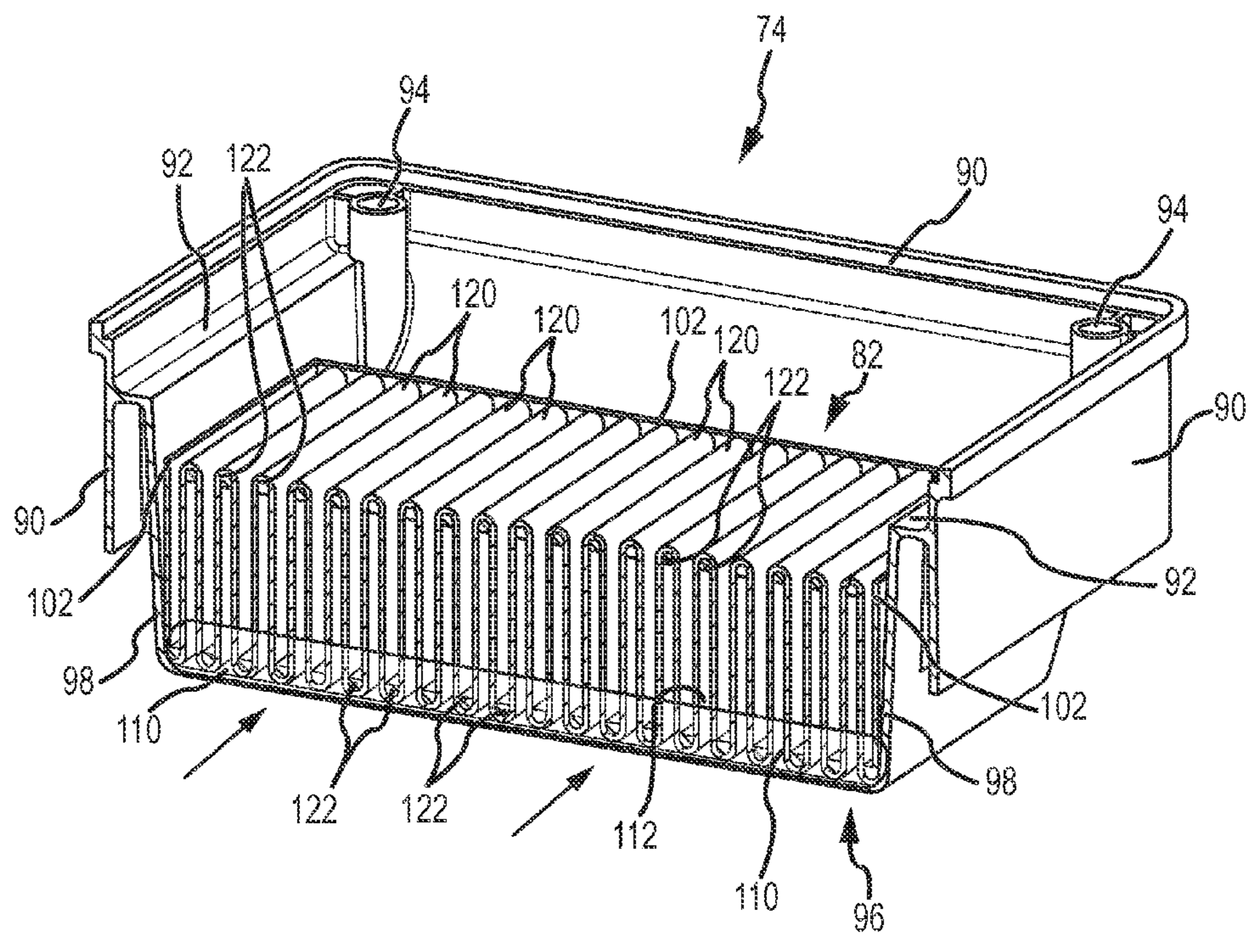

FIG.4

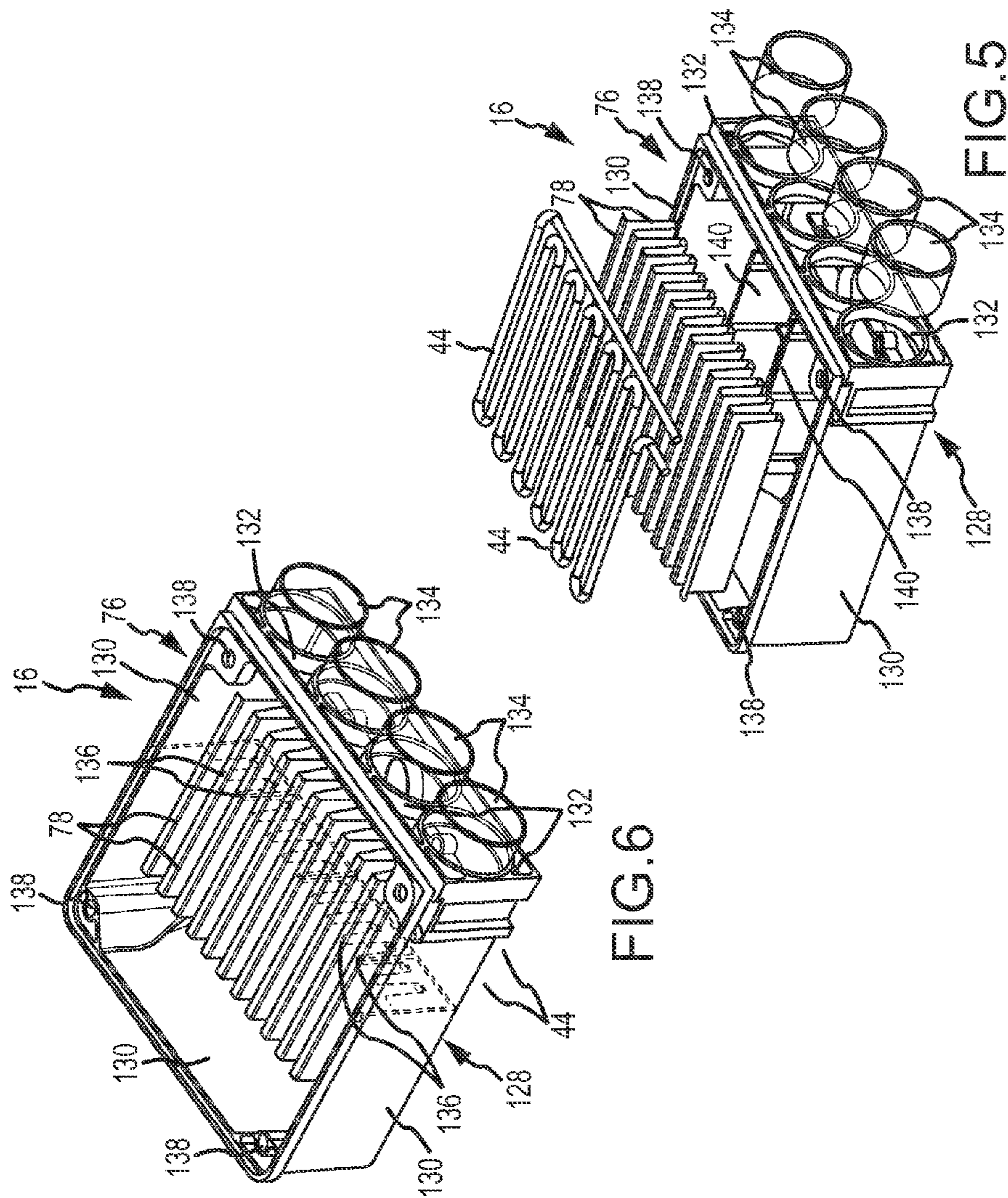

FIG. 5

FIG. 6



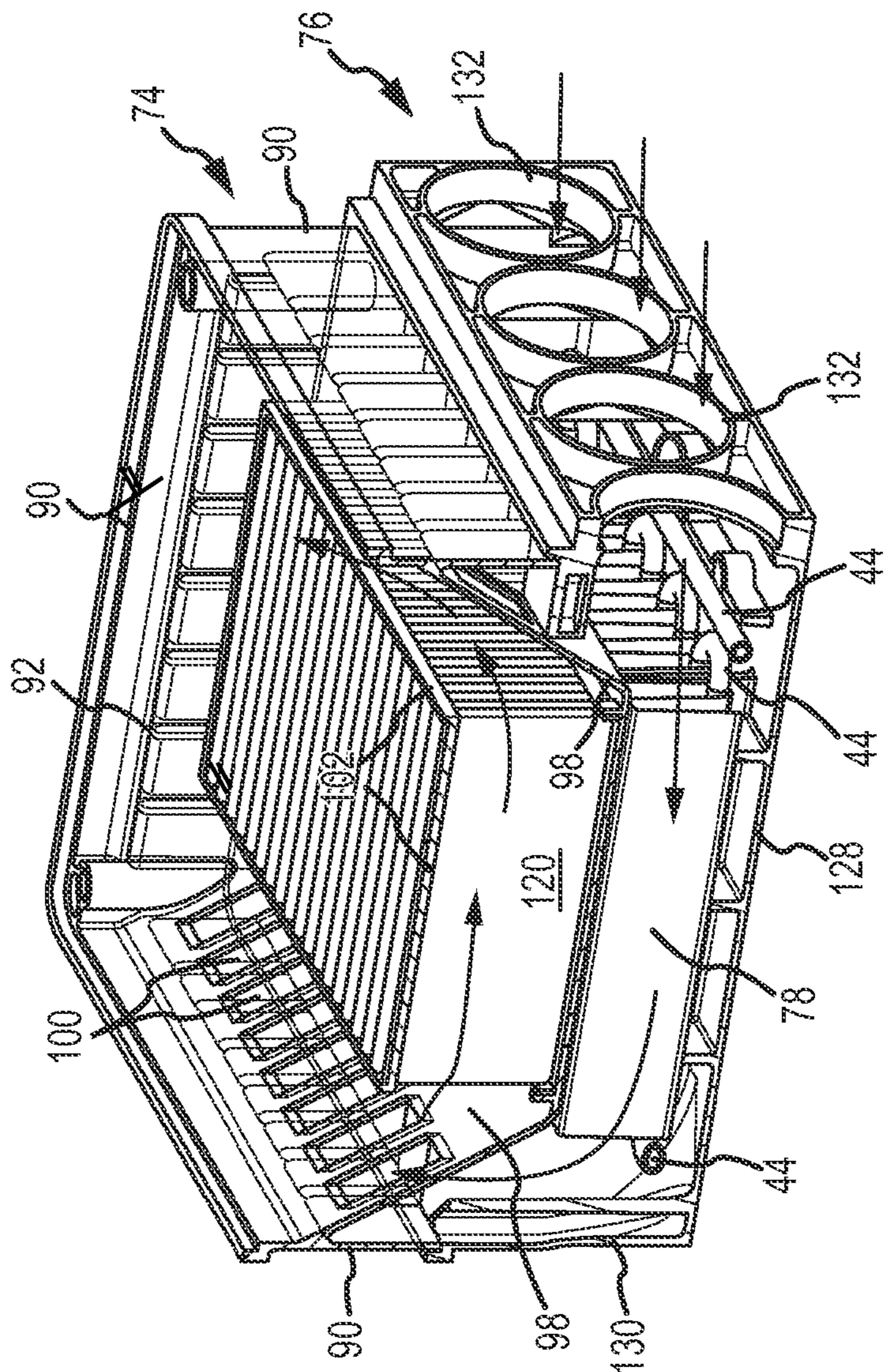

FIG.7

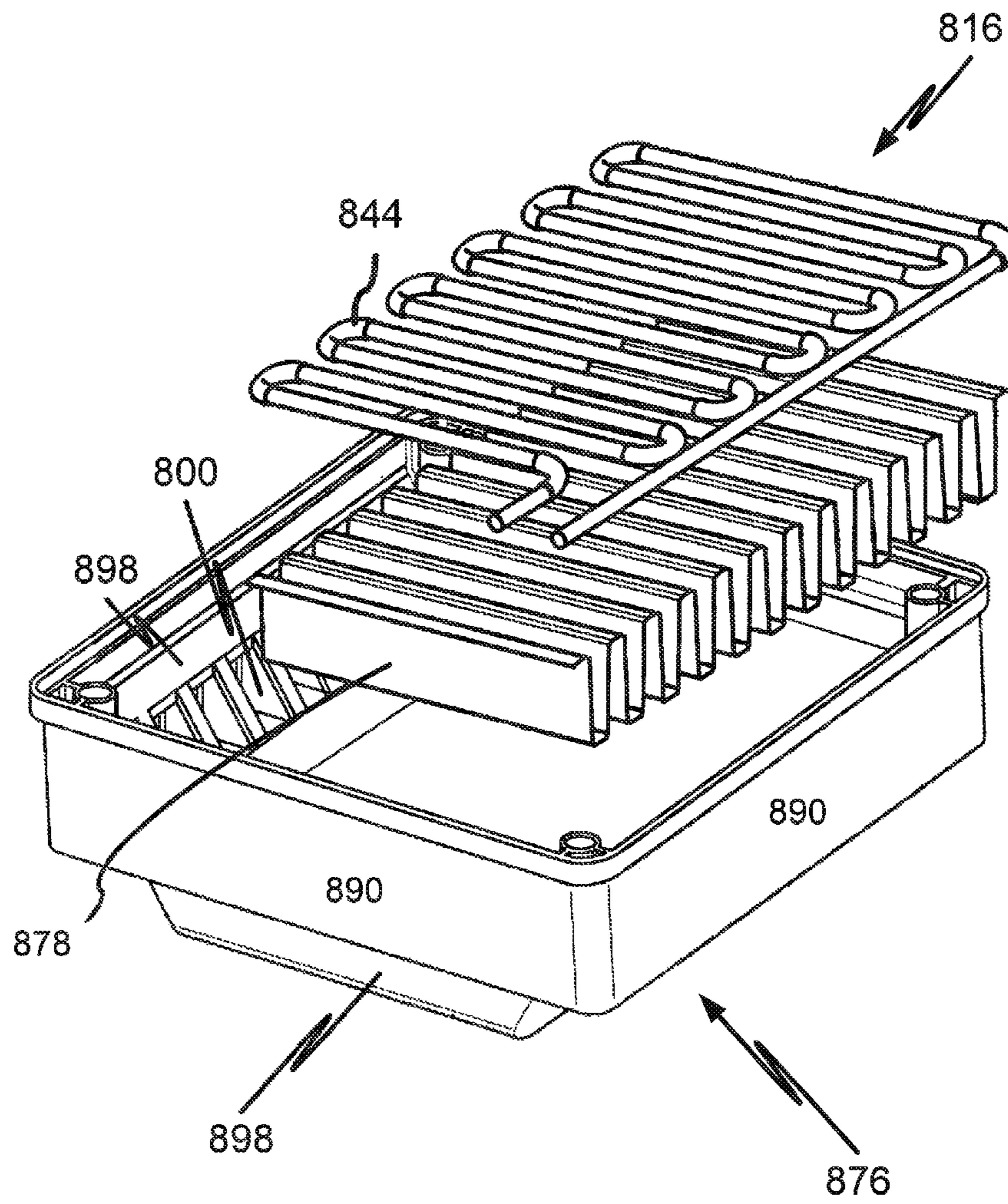

FIG.8



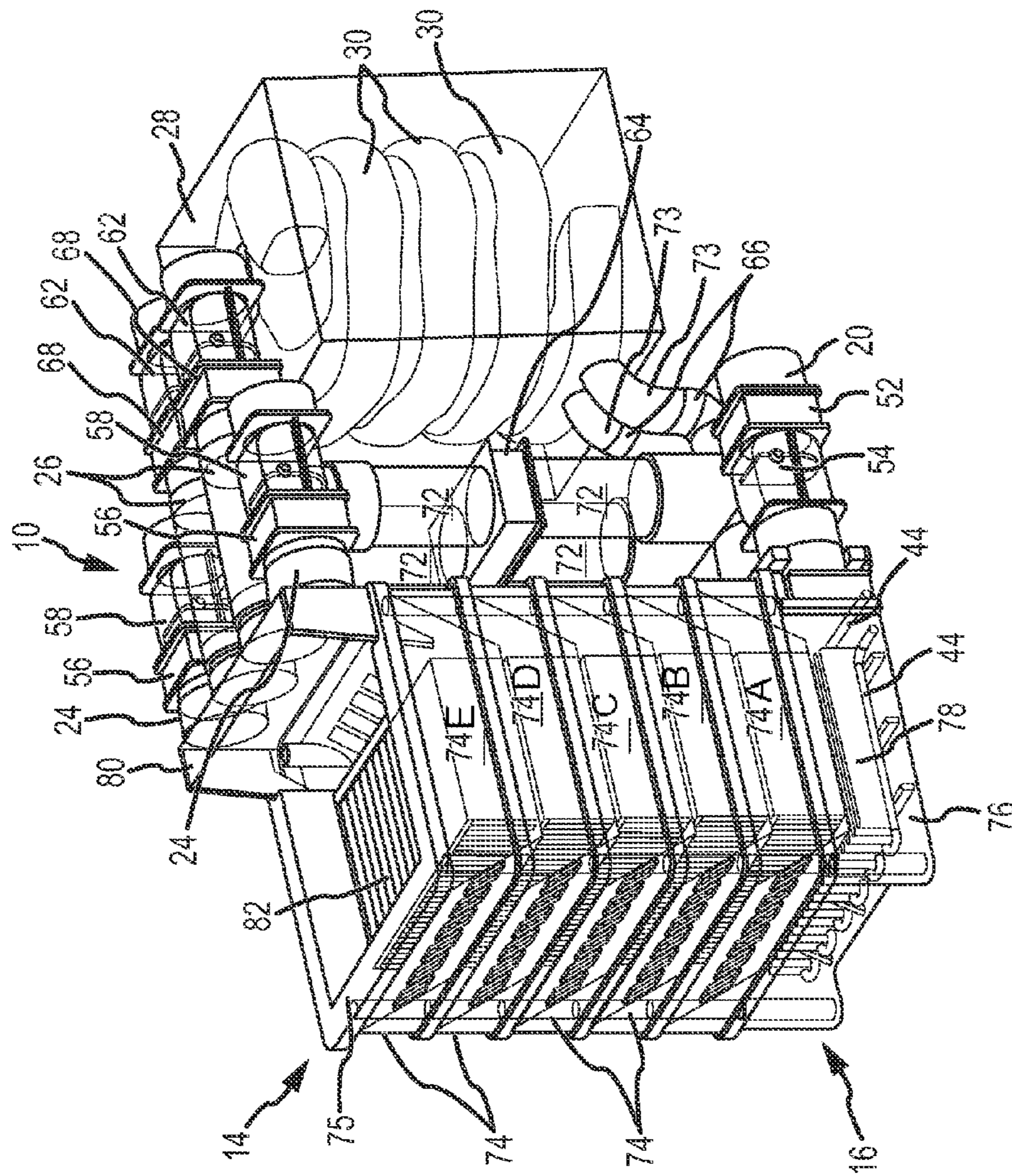

FIG.9

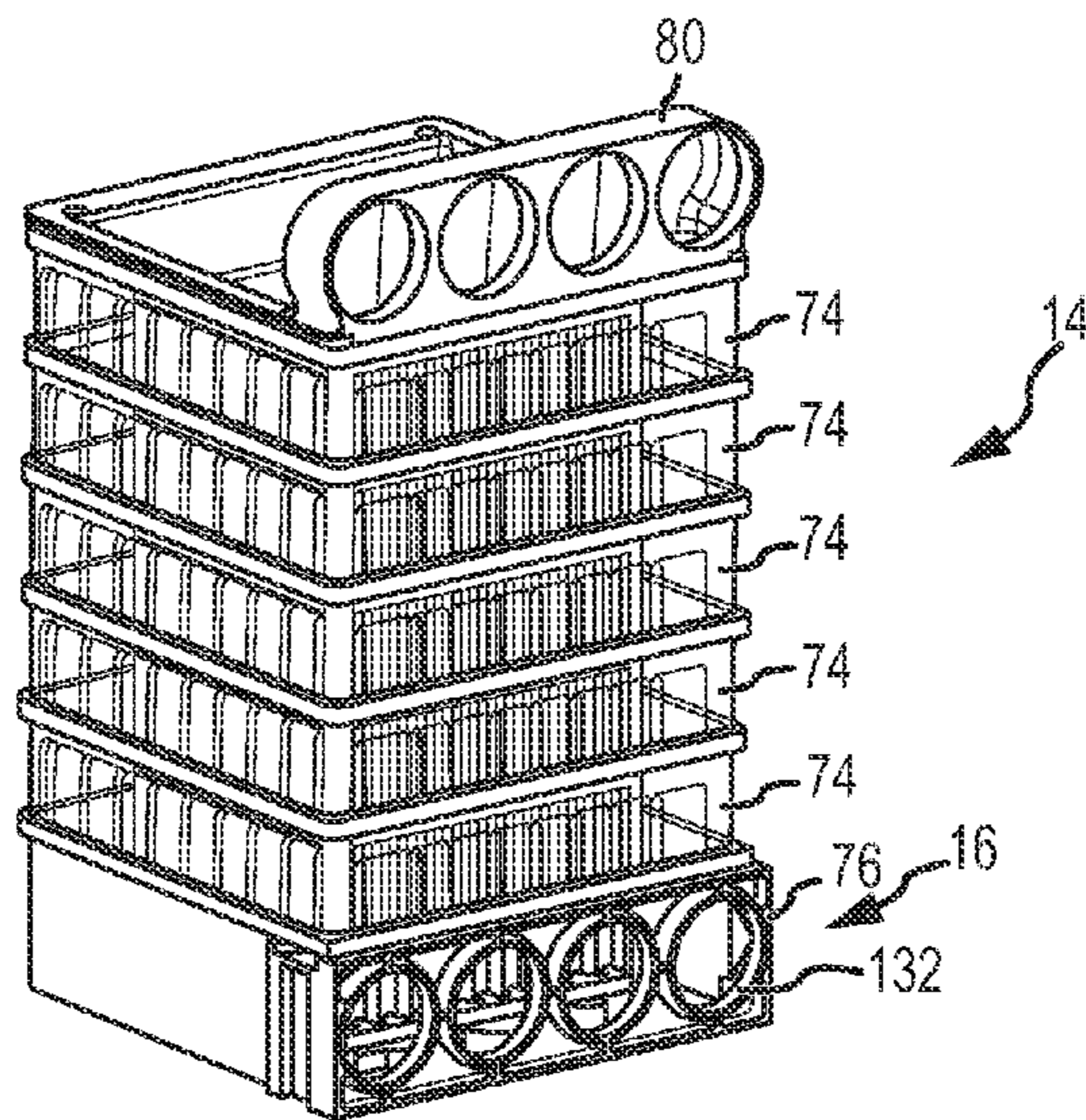

FIG. 10

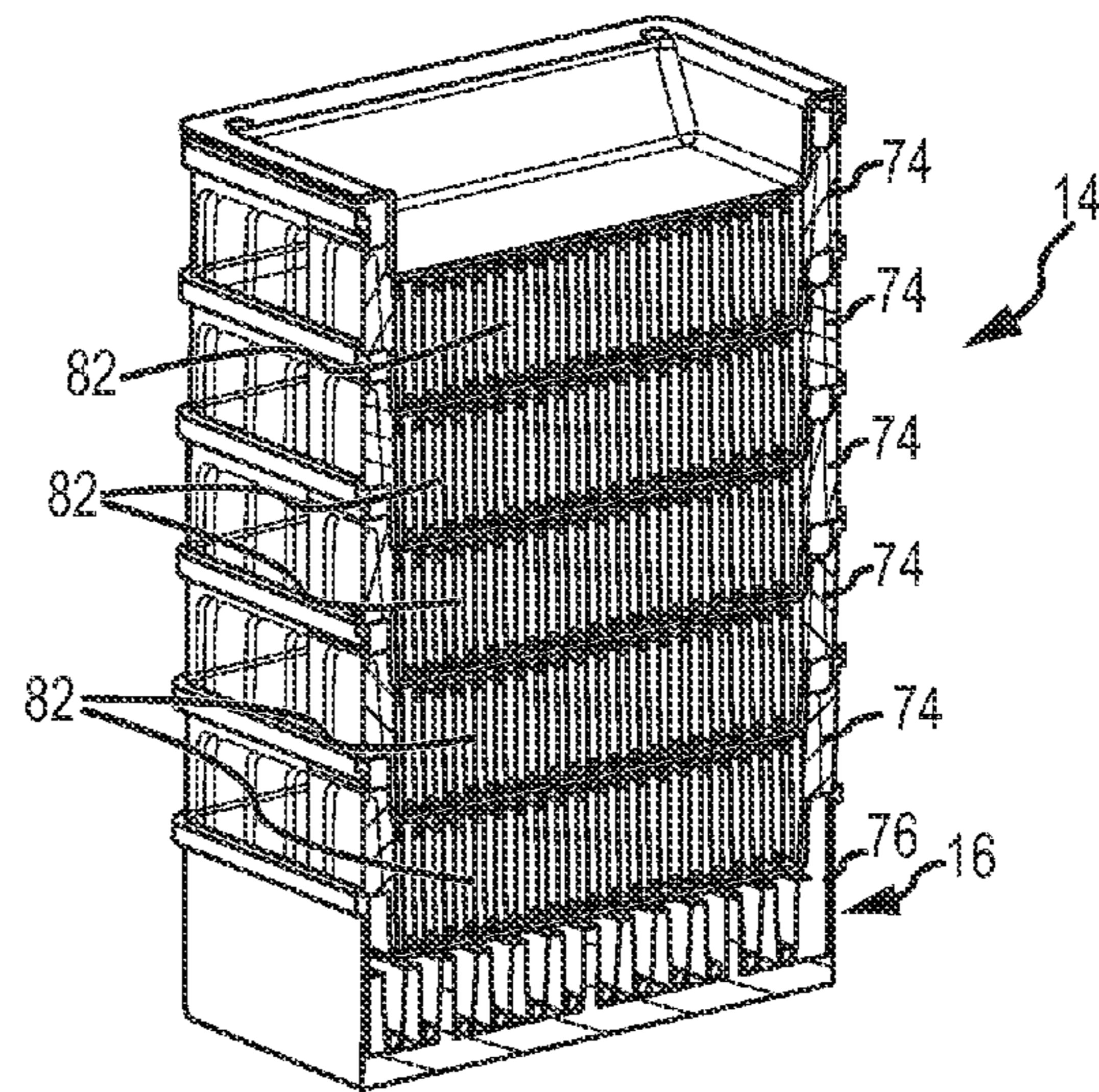

FIG. 11



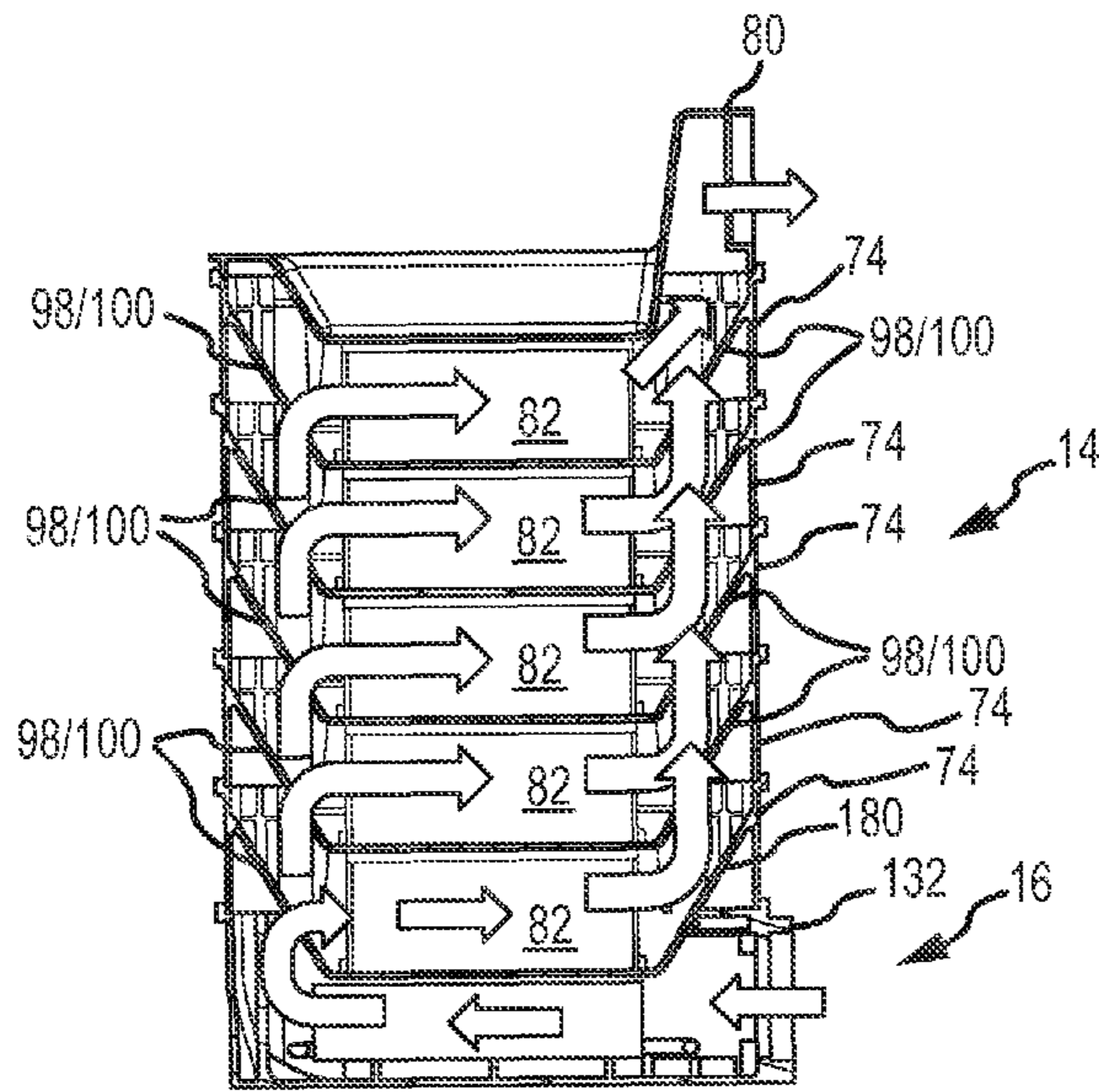

FIG. 12

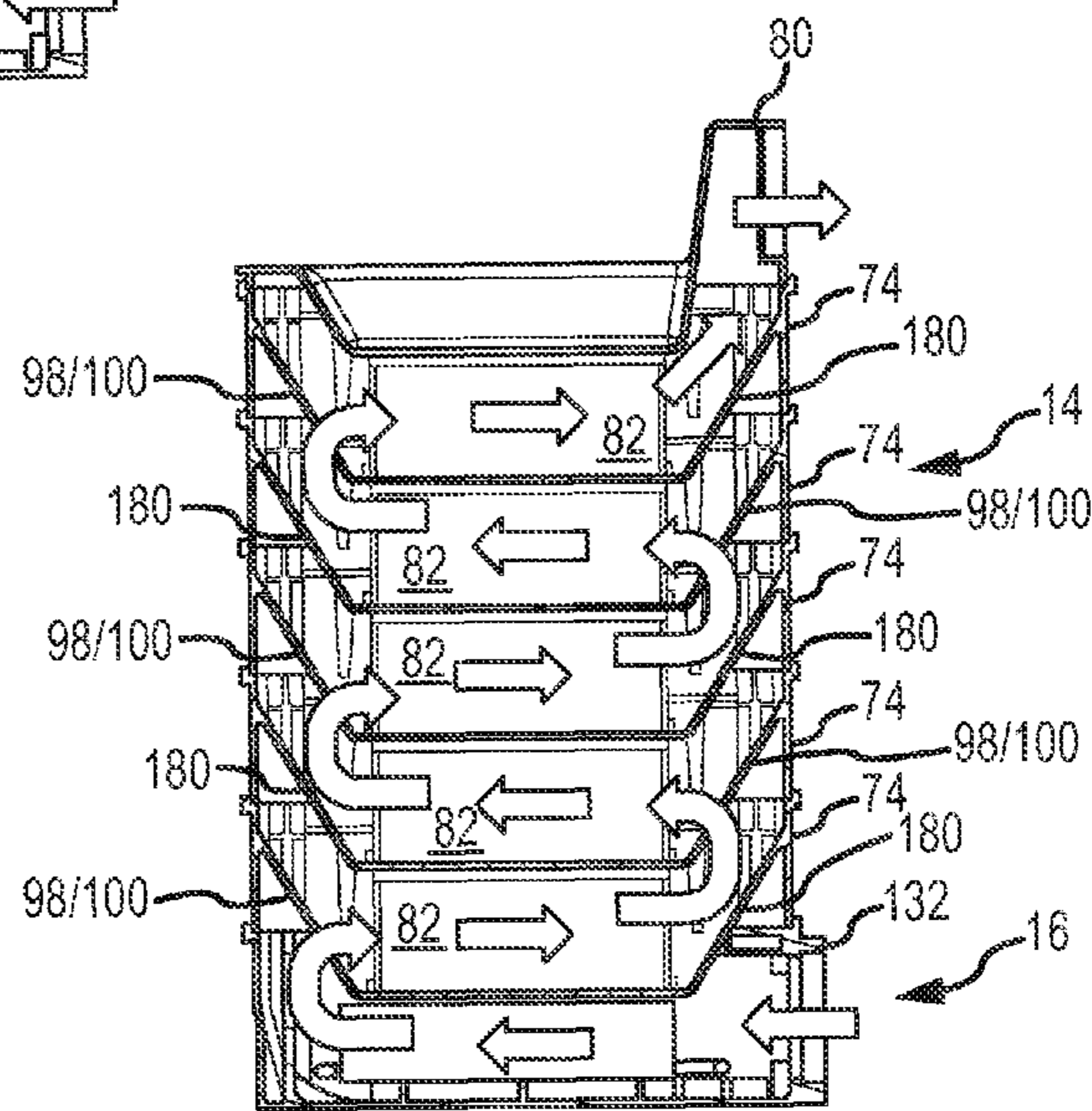

FIG. 13

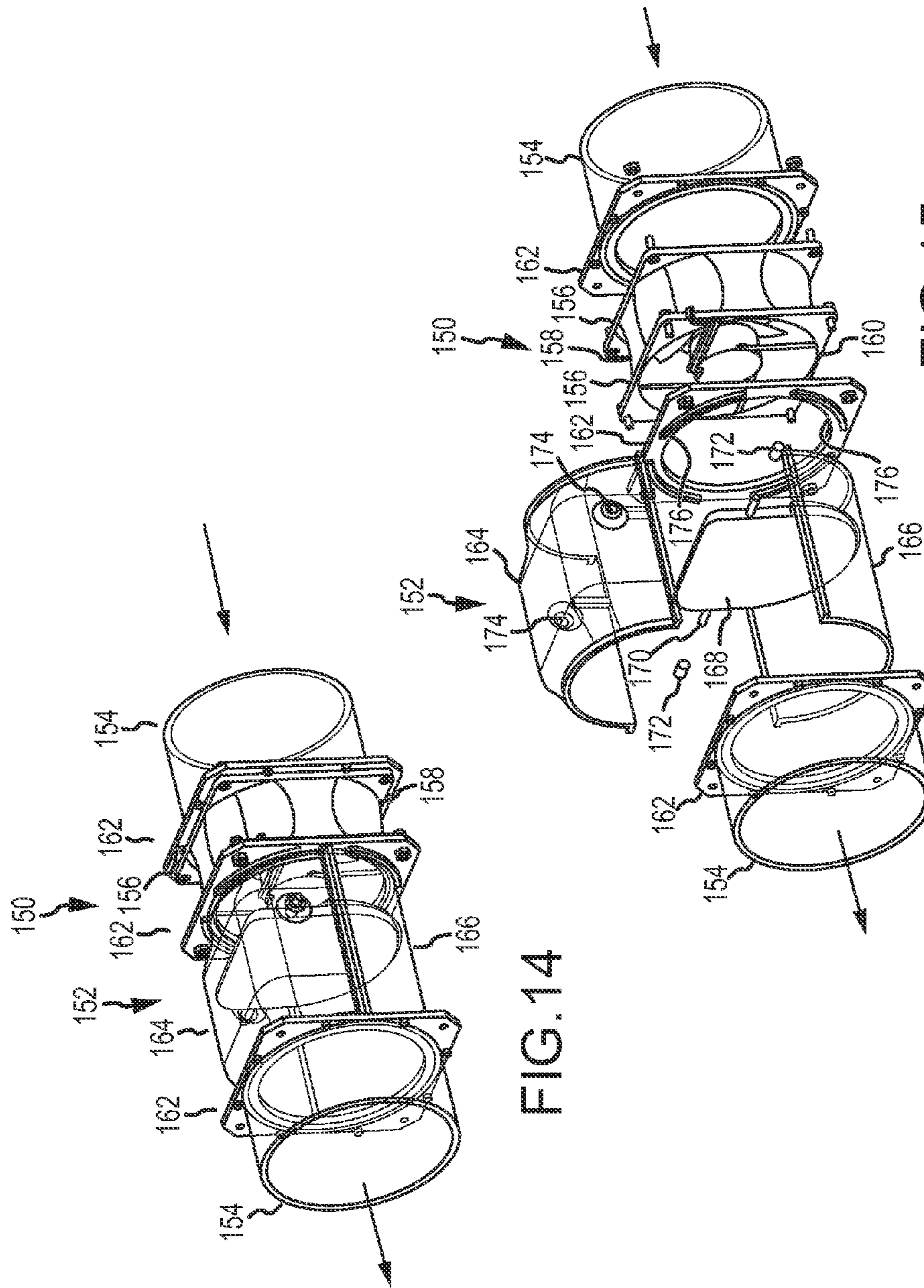

FIG.14

FIG.15



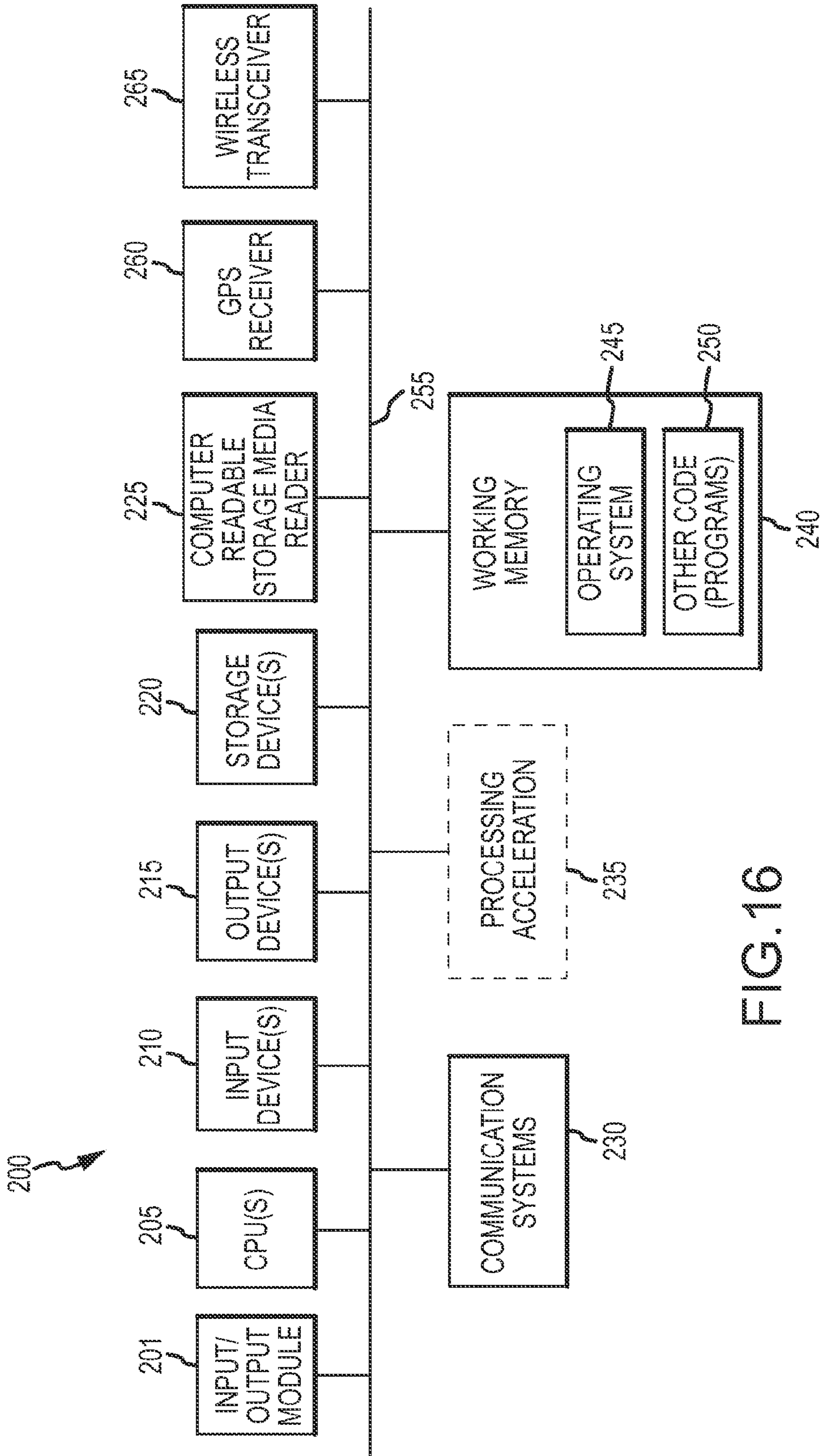
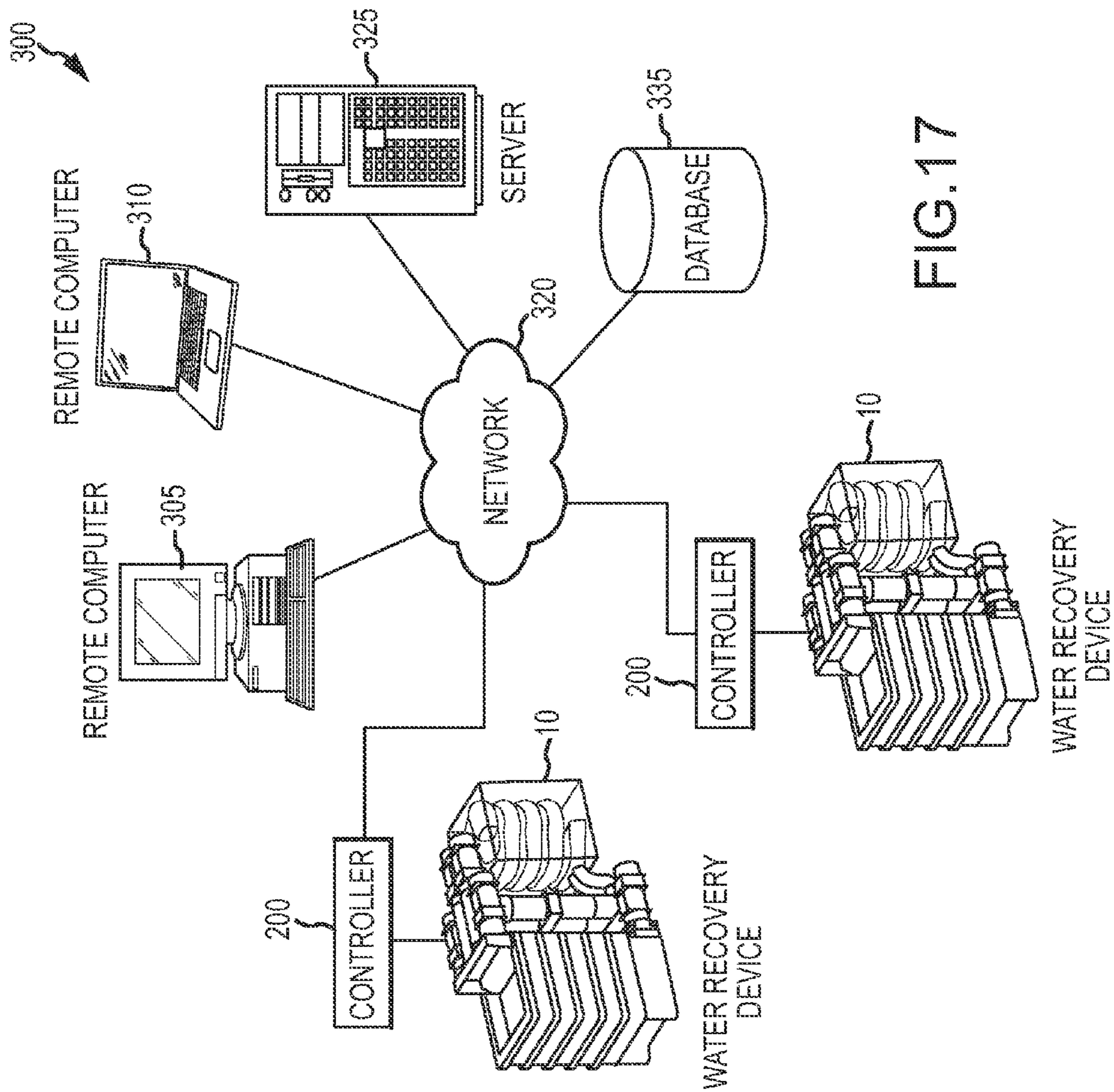

FIG. 16





## HEAT TRANSFER DEVICE FOR WATER RECOVERY SYSTEM

### CROSS REFERENCE TO RELATED APPLICATION

The present application claims the benefits of and priority, under 35 U.S.C. §119(e), to U.S. Provisional Application Ser. No. 61/655,316, filed Jun. 4, 2012, entitled "WATER RECOVERY SYSTEM AND METHOD," herein incorporated by reference in its entirety for all purposes.

### FIELD OF THE INVENTION

The invention relates to a water recovery system and method of recovering water from ambient air. More particularly, the invention relates to an apparatus/device and method using a desiccant solution to extract water from the air, and then separating the water from the desiccant. The recovered water may be treated to obtain potable water. A byproduct of the system and method is a stream of dehumidified air that may be used for conditioning an interior airspace within a man-made structure.

### BACKGROUND OF THE INVENTION

Potable water is often difficult to obtain in many locations throughout the world. In arid climates, there is simply a shortage of water and if water is available, it may be difficult to make the water potable without extensive water treatment resources. Even in wet climates, potable water may be in short supply because of the lack of treatment equipment. Unfortunate events such as war or general political conflict within a country often results in diminished infrastructure that would normally have the capability to provide potable water.

There are a number of known solutions for obtaining potable water by removing water vapor from the ambient air. One known method includes passing an airstream over a cool surface to condense the water vapor. This technique is well known, for example, in heating, ventilating, and air conditioning units (HVAC). In these types of systems, the condensed water however is usually considered as waste material, and is disposed of.

The use of solid and liquid desiccants is also known for extracting water from air. In a closed loop process, ambient air is passed through a chamber containing a desiccant soaked media. As the air passes in contact with the media, moisture from the air stream is removed by absorption into the desiccant. Heat is then applied to the desiccant media to vaporize the captured moisture. The water vapor is transported away from the chamber, and then condensed and collected. The desiccant is therefore re-concentrated and can be reused in a next water recovery effort.

Water recovery systems include the use of both solid and liquid desiccants. In liquid desiccant systems, one goal is to increase the exposed surface area of the desiccants to the air stream in order to maximize water vapor removal. One method of achieving this is to spray the liquid desiccant in a mist onto the media. However, a misting device adds to the complexity and cost of the system. Systems with solid forms of desiccants may provide a more compact construction. However, solid desiccants have relatively small exposed surface areas thereby limiting the capability to remove water vapor from a passing air stream.

One example of a reference that discloses the use of a liquid desiccant for recovering water from an airstream is the U.S.

Patent Application Publication No. 2011/0232485. The reference provides a composite desiccant material formed by a porous polyvinyl alcohol (PVA) foam or non-woven sheets of fiber soaked in a solution of a hygroscopic desiccant such as calcium chloride (CaCl). The desiccant is held in pores of the fiber material ranging in size from 50 microns to 1000 microns. The fiber material is provided in sheets arranged in a stack in a multi-chamber system. During an absorption phase, atmospheric or ambient air flows through the chamber. The water vapor is removed through contact with the desiccant, and is held in the fiber material. In a water recovery phase, energy is added to the chamber in the form of heat in order to release the water from the desiccant by evaporation. Fans circulate air through the chamber, and eventually into a water recovery chamber within a condensing area. Water is recovered in the condensing area, and the dried or water lean airstream leaving the chamber may be used to condition a man-made structure. As also set forth in this reference, a control system can be used to operate fans within the water recovery system when conditions of humidity and the remaining capacity of the desiccant stack are conducive to an efficient charging operation to remove water from the ambient air. The control system may also initiate a regeneration cycle when the availability of low grade heat energy and the degree of saturation of the desiccant are conducive to removing water from the desiccant, that is, when the degree of moisture in the chamber is high enough relative to the temperature of an available cold source for an efficient condensing operation. U.S. Patent Application Publication No. 2011/0232485 is herein incorporated by reference in its entirety for all purposes.

Another example of a patent reference that discloses a method and device for recovering water from ambient air is the U.S. Pat. No. 6,156,102. Specifically, this reference discloses separating water from air by the use of a liquid desiccant to withdraw water from air, treatment of the liquid desiccant to produce water, and regenerating the desiccant for subsequent use. In one preferred embodiment, the method disclosed includes providing a hygroscopic solution comprising a solute in an initial concentration; contacting the hygroscopic solution with ambient air containing water to obtain a water rich hygroscopic solution having a concentration of solute less than the initial concentration and a water lean airstream; separating the water lean airstream from the water rich hygroscopic solution; releasing the water lean airstream to the atmosphere; and treating the water rich hygroscopic solution to obtain water and to return the hygroscopic solution to its original state for re-use. U.S. Pat. No. 6,156,102 is herein incorporated by reference in its entirety for all purposes.

As described in the U.S. Pat. No. 6,156,102, the effectiveness of liquid desiccants can be expressed in terms of both their "drying efficiency" and "drying capacity". Drying efficiency is the ratio of total water exposed to the hygroscopic solution as compared to the amount of water removed. The drying capacity is the quantity of water that a unit mass of desiccant can extract from the air. The drying efficiency and drying capacity of a hygroscopic solution is in part dependent upon the pressure of the water vapor in the air and on the concentration of the solute. In general, a hygroscopic solution having a high concentration of solute and thus a low partial pressure of water vapor in the solute, more quickly absorbs water from air having a higher partial pressure of water vapor. Accordingly, the hygroscopic solution has an initial drying efficiency that is relatively high. As water continues to be absorbed during a water recovery process, the partial pressure of the water vapor in the solution increases and the rate of



water absorption slows down. Eventually, the hygroscopic solution and the air may reach equilibrium, and no more water will be absorbed by the hygroscopic solution. In a desiccant regenerative process for the hygroscopic solution, the collected water in the hygroscopic solution must be removed. U.S. Pat. No. 6,156,102 is herein incorporated by reference in its entirety for all purposes.

While the prior art may be adequate for its intended purposes, there is still a need for a water recovery system and method that takes advantage of a modular construction in order to provide an integral capability to control parameters for efficient recovery of water from an ambient airstream. There is also a need to provide a construction that is easily adaptable to maximize water recovery for a specific application or situation. There is also a need to provide a water recovery system and method in which pre-established logic can be used to control a water recovery device based upon known environmental factors and taking into consideration the necessary amount of water to be produced. There is yet further a need to provide a device and method that requires a minimum amount of energy for operation, and is conducive to accepting forms of waste heat for operation. There is also a need to provide a water recovery device and method that is reliable, simple to operate, and requires minimum intervention for daily operations. There is also a need to provide a water recovery device and method that is easy to transport, deploy and commission. There is also a need to provide a water recovery device in which monitoring of the concentration of the liquid desiccant solution is achieved automatically, in order to timely and efficiently recover water once the liquid desiccant solution has reached its water saturation limit. During the regenerative phase of a desiccant solution, it is preferable that the concentration of the desiccant does not become too high, which otherwise could result in crystallization or solidification of the liquid desiccant resulting in a reduced efficiency of the device until the desiccant chemical can be placed back into its optimal concentration with water.

#### SUMMARY OF THE INVENTION

The present invention includes a system and method for recovering water from an ambient airstream. Additionally, the invention achieves dehumidification of the airstream by removal of the water. The device is characterized by a group or stack of trays that hold an amount of liquid desiccant in each tray. A foam media absorbs or wicks the desiccant to increase the exposed surface area between the desiccant and the airstream that is passed through an enclosed chamber that holds the desiccant trays. A number of fans and dampers or valves are used to control the airflow through the chamber.

Operation of the device includes two cycles. The first cycle is a charge cycle in which ambient air is passed through the chamber, across the desiccant stack, and back to the environment. The desiccant causes water vapor in the airstream to be taken up and held in a foam media material that holds the desiccant. In a preferred embodiment, the desiccant is a liquid solution of CaCl and water that is impregnated into the foam media. The foam media may include a thin sheet of PVA that is arranged in an accordion folded manner to increase the surface area of the sheet that is exposed to the airstream. Once the desiccant media has absorbed a sufficient amount of water from the airstream, an extraction cycle is initiated to recover water from the desiccant solution. In this cycle, the chamber is isolated from the ambient air, and energy is added to the chamber in order to vaporize the water from the desiccant solution. In addition to heat energy, the interior pressure of the chamber may be reduced to lower the evaporation tempera-

ture required to vaporize the water. For example, a fan can be used to remove an amount of air within the chamber, and then the chamber can be sealed to maintain the lower pressure state. One or more fans circulate the air within the chamber across the desiccant media to increase the rate of evaporation. When the internal temperature of the chamber exceeds a dew point temperature, relative to the external ambient conditions, a condensing circuit is enabled to condense the water vapor from the internal chamber air. The extraction cycle may also be referred to as a regeneration cycle in which the removal of water from the desiccant solution regenerates the desiccant placing it in a condition for re-use in which the concentration of the desiccant is returned to an optimal percentage.

Heat energy may be added to the chamber through a water or glycol-based heat exchanger. There are several possible sources of heat energy that can be used to include solar collectors, photovoltaic cells, waste heat from nearby industrial sources, electrical heaters, and gas heaters, among others.

The condensed water is captured, and may be further treated in order to make potable water. For example, the recovered water may be filtered, exposed to an ultra violet light source, mineralized, chlorinated, or may be otherwise treated to make the water safe for consumption.

A controller is used to integrate and manage all system functions and input variables to achieve a high efficiency of operational energy use for water output. The controller uses sensor inputs to estimate the amount of water in the system, the power used, the power stored, and the relevant external and internal environmental conditions such as temperature, pressure, humidity, sunlight/darkness. During the extraction cycle the controller is used to control heat energy added to the chamber and to also control the condensing rate to therefore sustain continuous operation for recovering water from a previous charge cycle. The controller may take advantage of sensor inputs and software that incorporates a number of algorithms to maximize efficiency of operation. For example, the algorithms may synthesize these inputs to control heat energy added to the chamber in a manner that minimizes energy usage from heat delivery systems and from fans and other internal components. During the charging cycle, similar inputs and algorithms can be used to control power consumption of fans and other internal components and to ensure a maximum water uptake.

For both system cycles, the algorithms may define optimal operating conditions for a known geographical area and a known calendar date which comprises historical data regarding average temperature, humidity, and sunlight/darkness conditions. From these algorithms, a baseline operating sequence can be established, and then modified by actual environmental conditions at the time. The controller receives multiple inputs that measure temperature, humidity, and pressure of the device during operation. Consequently, the controller manipulates outputs to efficiently operate the device by controlling outputs such as fans, dampers, and heat energy added to the device. During an extraction or regeneration cycle, the controller monitors the amount of water removed from the chamber to ensure that too much water is not removed that could result in a high desiccant concentration and crystallization of the desiccant.

In another aspect of control, the invention may include a system in which one or more devices may communicate with remote computing devices within a communications network. These remote computing devices can be used to assist in control of the device(s) and to gather data from the devices or to send updated commands for device operation. Accordingly each controller may further include a wireless transmis-



sion and receiving capability. In this regard, a system of the invention may therefore also include multiple devices, each of the devices having a wireless communication capability.

In another aspect of control, the invention may include "location based" capabilities in which Global Positioning System (GPS), magnetometer or other location based sub-systems are used to identify location and orientation of the installed system. This information can be used to further exploit data about geographical and/or weather conditions to enable better system efficiencies. For example, knowledge of orientation and duration of sunlight, directions of prevailing winds, etc may be used to obtain better efficiencies for solar energy extraction and minimized fan power needs, respectively.

In another feature of the invention, the device has a modular construction in which the desiccant trays can be arranged in a desired configuration. Further, the modular construction takes advantage of uniform sized tubing and couplers/flanges that allow for easy assembly and disassembly of the device. Further, the fans and dampers may also be of uniform construction, therefore allowing interchangeability among components, for ease of assembly/disassembly.

In yet another feature of the invention, the modular construction allows for a number of different options for adding heat energy to the device. Each of the desiccant trays may be configured to connect to a heating assembly. The heating assembly, in a preferred embodiment, may include a heating coil placed in close proximity to heat distribution fins. The heating assembly itself may be configured as a stackable tray unit.

In yet another feature of the invention, the airflow through the chamber of the device may be dynamically configured to optimize desired water extraction. For example, each of the desiccant trays may include airflow openings on one or more sides of the trays that control the direction of airflow through the chamber. In one example, the airflow may take a torturous path through the chamber in which there is a single or serial path through each of the desiccant trays. In another example, the airflow may take a parallel flow pattern through the chamber in which there may be multiple paths available for airflow through the chamber. Accordingly, airflow through the chamber may be configured to best match fan capabilities in moving an optimum flow of air through the device.

In yet another feature of the invention, the dried airstream that is produced when leaving the device may be used for a number of applications, such as providing a humidity controlled airstream to condition an airspace within a building or other man made structure. Particularly in hot, humid climates, the dried airstream produced can greatly improve working and living conditions within habitable spaces.

Although calcium chloride is disclosed for use as a preferred chemical hygroscopic desiccant, it should be understood that there are a number of other hygroscopic desiccants that could be used. For example, lithium bromide, magnesium chloride, and lithium chloride are known as effective hygroscopic desiccants. However, one advantage of calcium chloride is that it is a non-toxic chemical, and is therefore safe to use.

In one aspect of the invention, it can be considered a system for recovering water from ambient air. In another aspect of the invention, it can be considered an apparatus for recovering water from ambient air with options for manual control, automatic control, or combinations thereof. In another aspect of the invention, it can be considered a system for dehumidifying ambient air for purposes of providing conditioned air for an interior space of a man made structure.

In another aspect of the invention, it may include various sub-combinations of the system and device. These sub-combinations may include (1) the desiccant stack, (2) the heat exchanger with the desiccant stack, (3) the desiccant stack and the condenser, (4) the desiccant stack, heat exchanger, and condenser, and (5) and the desiccant stack, heat exchanger, and condenser further in combination with a controller. Each of these sub-combinations has utility.

Other aspects of the invention include a construction for a desiccant cartridge, a method of selectively controlling air flow through a chamber for a water recovery device, a modular construction for a water recovery device utilizing easily assembled components, a method for controlling a charging cycle of a water recovery apparatus including the use of algorithms to optimize operation, a method for controlling an extraction cycle of a water recovery apparatus including the use of algorithms to optimize operation, a method of operating a water recovery device including the use of algorithms to minimize energy usage, a method of operating a water recovery device including the use of algorithms to provide an even and continuous operation of a water recovery device, and a method of controlling operation of a water recovery device incorporating a plurality of control inputs including various sensors, weigh scales, and flow meters.

Yet further aspects of the invention include a water recovery device utilizing multiple energy sources to power an extraction cycle, a method of determining optimal formulations for a liquid desiccant solution used within a water recovery device, a construction for a desiccant media including a formulation for a liquid desiccant solution, a water recovery device including configurable desiccant media cartridges, a method for selective and dynamic control of a liquid desiccant solution used within a water recovery device, a water recovery device including insulating and sealing components that effectively isolate airflow through the device and otherwise provide optimal temperature and pressure conditions within a chamber of the device, and a method for determining an optimal initial desiccant formulation of a water recovery device considering relevant geographical data corresponding to the geographical location where the device is to be installed.

Taking into consideration the above aspects and features of the invention, the invention can be further described as a water recovery device comprising (i) a desiccant stack including a chamber defining an airflow path therein, the stack including a plurality of desiccant trays; (ii) a condenser communicating with the desiccant stack; (iii) a heat source operative to add heat energy to the chamber; and (iv) wherein an airstream within the water recovery device is warmed prior to or during an extraction cycle, the extraction cycle operative to remove a retained water vapor from within the chamber, the condenser providing a cooling source to condense the water vapor and thereby producing an amount of water condensate.

The invention can yet be further described as a water recovery system comprising (a) a water recovery device including: (1) a desiccant stack including a chamber defining an airflow path therein, the stack including a plurality of desiccant trays; (2) a condenser communicating with the desiccant stack; (3) a heat source operative to add heat energy to the desiccant stack; wherein an airstream within the water recovery device is warmed prior to or during an extraction cycle, the extraction cycle operative to remove a retained water vapor from within the chamber, the condenser providing a cooling source to condense the water vapor and thereby producing an amount of water condensate; (b) a controller incorporated in the device for controlling functioning of the device to include an extraction cycle, the device further including a plurality of



7

sensors as inputs to the controller, and a plurality of valves as outputs of the controller, the valves being located within a heat transport line of the device; and (c) said water recovery device further including a communications node incorporated within a communications system enabling the water recovery device to communicate within the communications system.

Further still, a method is provided for recovering water vapor from ambient air, said method comprising: providing a water recovery device including (i) a desiccant stack having a chamber defining an airflow path therein, the stack including a plurality of desiccant trays; (iii) a heating source communicating with the desiccant stack for providing heat to the desiccant stack; (iv) at least one heating line, the heating line communicating with the heat source; (v) at least one heating element, the heating element communicating with the heating line, the heating element operative to provide heat to the desiccant stack; and operating the device in an extraction cycle to remove the retained water vapor within the chamber; and condensing the water vapor by a cooling source within the condenser thereby producing an amount of water condensate.

The preceding is a simplified summary of the disclosure to provide an understanding of some aspects of the invention. This summary is neither an extensive nor exhaustive overview of the disclosure and its various aspects, embodiments, and/or configurations. It is intended neither to identify key or critical elements of the disclosure nor to delineate the scope of the disclosure but to present selected concepts of the disclosure in a simplified form as an introduction to the more detailed description presented below. As will be appreciated, other aspects, embodiments, and/or configurations of the disclosure are possible utilizing, alone or in combination, one or more of the features set forth above or described in detail below. Therefore, other features and advantages of the present disclosure will become apparent from a review of the following detailed description, taken in conjunction with the drawings.

#### BRIEF DESCRIPTION OF THE DRAWINGS

FIG. 1 is a schematic diagram of the device of the invention in one preferred embodiment;

FIG. 2 is an exploded perspective view of a desiccant tray and desiccant media cartridge;

FIG. 3 is another perspective view of the desiccant tray with the desiccant media cartridge mounted within the tray;

FIG. 4 is a vertical section of the desiccant tray of FIG. 2 showing details of the arrangement of the desiccant media cartridge and an amount of desiccant solution within the tray;

FIG. 5 is an exploded perspective view of a heat exchanger assembly;

FIG. 6 is a perspective of the assembled heat exchanger assembly of FIG. 5;

FIG. 7 is a vertical section of a desiccant tray mounted over a heat exchanger assembly, illustrating the relationship between heat distribution elements of the heat exchanger and the desiccant tray;

FIG. 8 is a perspective view of a heat exchanger tray with a heat exchanger mounted in the tray;

FIG. 9 is a fragmentary perspective of the device in a preferred embodiment;

FIG. 10 is a perspective view of a preferred embodiment of a desiccant stack including a plurality of vertically stacked desiccant trays, a heat exchanger assembly located beneath the desiccant trays, and a stack exhaust manifold for directing exhaust air from the desiccant stack;

8

FIG. 11 is a vertical section of FIG. 10 illustrating the relationship between the desiccant trays and the heat exchanger assembly;

FIG. 12 is a schematic diagram of a desiccant stack, and one configuration for an airflow path through the chamber, referred to herein as a parallel flow path;

FIG. 13 is another schematic diagram of a desiccant stack, and another configuration for an airflow path through the chamber, referred to herein as a serial flow path;

FIG. 14 is an exploded perspective of components of the device including a fan and damper/valve combination;

FIG. 15 is an assembled perspective of the components of FIG. 14;

FIG. 16 is a schematic diagram of components of a controller that may be used in conjunction with control of the device; and

FIG. 17 is a schematic diagram of a communication system, including a plurality of devices with integral controllers operating within a communications network in which one or all of the devices may communicate with other communication nodes of the network, to include download and upload of data and commands.

#### DETAILED DESCRIPTION OF THE DRAWINGS

Referring to FIG. 1, a schematic diagram is shown for purposes of illustrating the major functional components of a device of the system. Specifically, the device 10 includes a housing 12 that defines therein an interior space or chamber for receiving a flow of air to remove water vapor from the airstream. The chamber is more specifically defined as including a desiccant stack 14 including a plurality of desiccant trays 74 (see FIG. 2) that each holds a desiccant media material.

Each of the trays 74 have a quantity of a liquid desiccant solution placed in contact with the desiccant media material that wicks or absorbs the solution, as set forth further below with respect to the description of the FIGS. 2-4. The device 10 further includes one or more heat exchanger assemblies 16 for providing heat to the chamber. A weigh scale 18 is used to monitor the mass of water vapor that is collected from the airstream during a charge cycle, as well as the mass of water vapor that is removed from the liquid desiccant solution during an extraction cycle.

An ambient or environmental or ambient air intake line 20 provides an entry point for the ambient air to enter the chamber area. The ambient air entering the chamber follows a flow path 22 through the heat exchanger assembly 16 and the desiccant stack 14. In the schematic diagram of FIG. 1, the flow path 22 illustrates a winding or torturous path, which is explained in more detail below with respect to configurable flow paths shown in the FIGS. 11 and 12. An exhaust line 24 returns the airstream that has traveled through the chamber back to the atmosphere. Alternatively, the exhaust line 24 may communicate with ductwork of a man made structure (not shown) to provide a conditioned airstream for the structure.

The airstream through the chamber may take one of several paths, depending upon the particular cycle in which the device is operating at the time. In the case of a charge cycle, the airstream is exhausted to the atmosphere or manmade structure through the exhaust line 24. During an extraction cycle, air within the chamber exits the chamber through the condenser inlet line 26 that interconnects the chamber with the condenser 28. Also during an extraction cycle, prior to when air within the chamber reaches the desired saturated state ready for condensing, air is re-circulated through the chamber by re-circulating line 72, as also discussed below.



FIG. 1 also schematically illustrates a cooling coil 30 that is used to condense the moist airstream for extraction of water vapor from the airstream. An ambient air cooling line 32 is also illustrated within the condenser 28. During the extraction cycle, ambient air is used as the cooling source for condens-  
 5 ing the warmer, moist airstream that has entered the cooling coil 30. A water collection container 34 is provided for collecting the condensed water by water line 36 that interconnects the condenser 28 to the container 34. A weigh scale 38 may also be used to monitor the amount of water extracted. In  
 10 conjunction with scale 18, the scale 38 provides control inputs for monitoring water recovery.

The heat exchanger assembly 16 includes a heat source 40. The heat source 40 in the schematic of FIG. 1 is shown as a solar collector or photovoltaic cell; however the heat source  
 15 could be many other sources such as an electric or gas heater, or available waste heat sources. For example, the heat source could include waste heat from an industrial process, or waste heat captured from the exhaust manifold or engine of a  
 20 vehicle. A closed loop heating line 44 is used to re-circulate an amount of heating fluid. As shown, the heating line 44 traverses through the chamber and in close proximity with the desiccant stack 14. The heating fluid 42 may be a conven-  
 25 tional heating fluid such as water or glycol. A heating fluid container 45 is provided to store the heating fluid. A fluid pump 70 is used to re-circulate the heating fluid 42 through the heating line 44. Although FIG. 1 illustrates the heat source 40 and container 45 as separated from the other components  
 30 of the heat exchanger assembly 16 within the chamber, it shall be understood that the heat exchanger assembly 16 could be housed in a number of different configurations to accommodate the particular application which the device is being used.

A controller 84 may be used to provide automatic control of the operation of the device. The controller 84 may take the  
 35 form of known industrial controllers that accommodate control inputs and outputs, and a processor with integral software or firmware. With respect to inputs, the device may be monitored by a number of temperature sensing devices 46, such as thermocouples or RTDs. In FIG. 1, there are a number of  
 40 temperature sensors shown at various locations throughout the device. Within the heat exchanger assembly, a number of temperature sensing devices 46 are also shown to include sensors located within the heat exchanger, and within the  
 45 heating line at the entrance and exit from the heat source 40. A number of temperature sensors are also illustrated within the desiccant stack 14, as well as within the condenser 28.

In addition to temperature control, the FIG. 1 also illustrates a liquid flow sensor 48 that measures the flow rate of the  
 50 heating fluid 42 through the heating line 44. An airflow sensor 49 may also be incorporated within the exhaust line 24 to monitor the flow rate of air through the chamber. Further, a number of relative humidity sensors 50 may be incorporated within the device to measure relative humidity of the air-  
 55 stream. As shown in FIG. 1, relative humidity sensors 50 may be co-located with temperature sensors 46 at the exhaust line 24, at the condenser return line 73, and at other selected locations in which it may be desirable to monitor the relative humidity.

With respect to controlling airflow through the device, a number of fans may be used to precisely control airflow.  
 60 Referring again to the FIG. 1, the fans may include an intake fan 52 communicating with the air intake line 20, an exhaust fan 56 that communicates with the exhaust line 24, a condenser fan 68 that introduces air into the condenser 28 along  
 65 condenser inlet line 26, a re-circulating fan 64 that re-circulates air through the chamber through re-circulating line 72, and an ambient air cooling fan 69 that introduces ambient air

into the condenser 28. Control of air flow through the device is also achieved through a number of dampers or valves. Again referring to the FIG. 1 valves used to control air flow may include an air intake valve 54 mounted in the air intake  
 5 line 20, an exhaust valve 58 that is mounted in the air exhaust line 24, a condenser inlet valve 62 that is mounted in the condenser inlet line 26, and a re-circulating valve 66 that is mounted in the condenser return line 73.

Referring now to FIGS. 2-4, a desiccant tray 74 is illustrated in accordance with a preferred embodiment. The tray  
 10 74 includes sidewalls 90, and a base 96. One or more of the sidewalls 90 may include rod receiving channels 94 that receive rods or dowels (not shown) that stabilize the connection between stacked trays 74. At least one pair of opposing  
 15 sidewalls 90 may include an interior flange 92 for mounting a sealing gasket 75 (see FIG. 8). Preferably, there is a sealing gasket placed between each stacked tray 74 to thereby limit airflow loss through the chamber. The base 96 holds an  
 20 amount of liquid desiccant solution 110 (FIG. 4). The base 96 includes base sidewalls 98, and one or more of the sidewalls 98 may include a plurality of airflow circulation slots or openings 100. As shown, these openings 100 are disposed at  
 25 the upper portion of base sidewalls 98, above the liquid line 112 of the liquid desiccant solution 110, and below the top edge of the sidewalls 90. FIGS. 2-4 also illustrate a desiccant media cartridge 82 that is placed within the desiccant tray 74,  
 30 as best illustrated in the FIG. 3. The media cartridge 82 is shown as a rectangular shaped element that fits within the confines of base sidewalls 98. The media cartridge 82 includes a media frame 102 that holds media material 120 in  
 35 an accordion folded configuration. The media frame 102 may also include one or more frame panels 104 that can be used to direct airflow through the chamber by preventing air from passing through the panels 104. In the FIG. 2, it is intended to  
 40 show that the two end walls of the media frame 102 include media frame panels 104, while the opposing sidewalls of the media frame 102 remains open thereby allowing airflow horizontally through the media cartridge 82. In order to stabilize the open sides of the frame 102, the frame may further include  
 45 screen supports 106 comprising a plurality of wire elements as shown.

Referring to FIG. 4, the media material 120 is illustrated in the form of a thin sheet that is held in the accordion folded  
 50 configuration to thereby maximize the exposed surface area of the media material to air passing through the chamber. As shown, the desiccant solution 110 fills a portion of the base 96, and the lower end of the media material 120 is submerged in the fluid solution 110. As mentioned, one example of an acceptable media material may include a thin sheet of PVA  
 55 foam, an absorbent foam that readily wicks the desiccant solution 110. In order to maintain the media material in the accordion folded configuration with uniform gaps or spaces between the folds of material, an internal wire support 122 may be used for stabilizing the media material. When the  
 60 media material 120 absorbs or wicks the desiccant solution 110, the material serves to evenly distribute the desiccant solution in large surface area within a confined space. Accordingly, the media material 120 and the desiccant solution 110 provide a hygroscopic feature to effectively remove  
 65 water vapor from a passing airstream. As shown in the FIG. 4, the media material 120 is preferably oriented in a parallel relationship with the flow of air, thereby enabling air to pass through the gaps between the folds of the media material. In this orientation, the airstream maintains significant contact  
 with the exposed surfaces of the media material. As air continues to flow through a media cartridge 82, the amount of water vapor retained in the media material increases. It is



possible for the amount of retained water vapor to exceed the liquid holding capacity of the media material, resulting in dripping of the desiccant solution into the pool of desiccant fluid **110**. As discussed further below, it is advantageous to begin an extraction cycle prior to complete saturation of the media material.

The thickness of the media material, as well as the configuration of the media material in terms of the size of the gaps between folds of the media material can be adjusted to meet the desired water recovery needs for a particular use. Thinner sheets of material with larger gaps between folds of the material allows for better airflow through the chamber, thereby reducing the airflow pressure drop through the chamber. However, this configuration of the media material limits the amount of water vapor that can be removed from the airflow. Reducing the size of the gaps between the folds of the media material and increasing the width of the media material results in increased capability to remove water from the airflow, but with the disadvantage of increased pressure drop through the chamber therefore requiring greater fan capacity in moving air through the chamber. It is therefore contemplated to adjust the particular configuration of the media material so that water recovery is achieved to meet the needs of the particular use of the device without excessive air pressure drop through the device that may exceed the capacity of the fans.

The desiccant solution **110** is placed in each of the trays **74**. This may be done manually at the start of operation of the device. As the device continues to operate, it may be necessary to replenish the desiccant solution. For example, some portions of the desiccant media that absorb the desiccant solution may become dried and crystallized, thereby preventing reactivation of the desiccant chemical without cleaning and re-soaking the desiccant media. In lieu of manually replacing the desiccant solution **110**, it is also contemplated that the desiccant solution **110** may be automatically replenished. A desiccant solution reservoir (not shown), and a water reservoir (not shown) may have fluid conveying lines that connect to each or selected ones of the trays **74**. Each of the trays may also include a liquid level sensor (not shown) and/or a desiccant concentration sensor (not shown) to sense the concentration of the chemical desiccant. Chemical concentration sensors are devices that measure the electrical potential of a solution, and changes in the electrical potential correspond to known changes in the concentration of a chemical within the solution. Based on inputs from these sensors, replenishment valves (not shown) mounted in the fluid conveying lines could be selectively opened to release a designated amount of water and/or desiccant solution in order to replenish the desiccant solution in the trays. In many cases, it may only be necessary to add water back to the desiccant solution in order to place it at the optimum desiccant concentration.

Referring now to FIGS. **5** and **6**, components are illustrated for the heat exchanger assembly **16** that may reside below a desiccant stack **14**. As shown, the assembly includes a housing **76**, including sidewalls **130** and a bottom wall or base **128**. One side of the housing **76** includes a tubing manifold **132** with openings to receive corresponding tubing sections **134**. Extending upward from the base **128** is a plurality of baffles **140** that are used to support the heating distribution element **78**. As shown, the heating distributional element **78** may be an accordion folded element that fits between the sidewalls **130** and disposed above the heating line **44**. The heating line **44** is configured in a winding path to thereby more evenly transfer heat to the heat distribution element **78**. The heating line **44** passes through one of the sidewalls **130** as shown in FIG. **6**,

and communicates with the heat source **40** and container **45** (FIG. **1**). Optionally, a wire support element **136** maybe disposed within the housing **76** in order to maintain the heating element **78** in its accordion folded configuration. The heat distribution element **78** may be made from aluminum or another type of corrosive resistant conductor. The housing **76** may also include rod receiving channels **138** that align with channels **98** of the desiccant trays **74** to receive stabilizing rods (not shown) that help to hold the desiccant stack and heat exchanger assembly in a stabilized vertical orientation.

Referring to FIG. **7**, the arrangement of a desiccant tray **74** is shown with respect to the heat exchanger housing **76**. As shown, the base or bottom portion of the desiccant tray **74** is located in close proximity to the upper surfaces the heat distribution element **78**. This orientation may allow for most efficient heat transfer to the overlying tray **74**. FIG. **7** also illustrates the available space for air entering the device in which the air first passes through the gaps between adjacent sections of the heat distribution element **78**. The airstream is then directed upwards, through the openings **100** in the base sidewall **98** of the tray. Next, air is forced horizontally through the gaps in the media material **120** and substantially parallel with the orientation of the media material **120**. The air then travels upward into the next desiccant tray **74**. The path of airflow through this next desiccant tray may be dictated by the orientation of the openings **100** in the base sidewalls **98** of the tray.

Further, it is contemplated that a desiccant stack may take advantage of multiple heat exchanging assemblies powered by a single source of power. For example, a desiccant stack **14** may include one or more heat exchange assemblies such as heat exchange assembly **16** or heat exchange assembly **816**, which are disposed throughout a desiccant stack **14** and between one or more desiccant trays **74**. As shown in FIG. **8**, heat exchanger assembly components, such as a heat distribution element **878**, a heating line **844**, and one or more sensors, may be housed in a modified tray **876**. Modified tray **876** may be modular in design such that tray **876** may be placed within a desiccant stack **14**; that is, tray **876** may be stacked on top of desiccant trays **74**, and/or desiccant trays **74** may be stacked on top of tray **876**.

As shown in FIG. **8**, heating assembly **816** may include similar components to those of heating assembly **16**. As shown, heating assembly **816** includes a housing **876**, sidewalls **890** and a bottom wall or base **898**. The heating distributional element **878** may be an accordion folded element that fits between the sidewalls **890** and disposed below the heating line **844**. The heating line **844** is configured in a winding path to thereby more evenly transfer heat to the heat distribution element **878**. The heating line **844** eventually passes through one of the sidewalls **870** and communicates with the heat source **40**. Heating line **844** may or may not connect to container **45** (FIG. **1**), depending on whether heating element **844** is a fluid type heating line or an electrical type heating line.

Heating line **844** may be configured to communicate with heat source **40** in a variety of ways. For example, heat source **40** may communicate with heat exchange assembly **16** and one or more heat exchange assemblies **816** using a plurality of fluid distribution lines. The plurality of fluid distribution lines may be arranged in a parallel or serial manner such that each heat exchange assembly **16** and/or heat exchange assembly **816** directly communicates with the heat source **40**. Alternatively, or in combination, the plurality of fluid distribution lines may be arranged in a serial manner—that is, each heat exchange assembly **16** or **816** may communicate directly with a previous heat exchange assembly **16** or **816**. In such a serial



## 13

configuration, Heating line **44** or **844** may further be configured to connect to a fluid distribution line utilizing quick connect fittings to further modularize the installation and removal of heating assembly **816** in a desiccant stack **14**.

Similar to desiccant tray **74**, heat exchange assembly **816** includes sidewalls **898**, and one or more of the sidewalls **898** may include a plurality of airflow circulation slots or openings **800**. As shown, these openings **800** are disposed at the upper portion of base sidewalls **898**. Openings **800** direct the airflow in an orientation most efficient for transferring heat from heat exchange assembly **816** to the surrounding airstream. For example, the airstream may first enter the heat exchange assembly **816** through openings **800**. The airstream then is forced horizontally through the gaps between adjacent sections of the heat distribution element **878**. The airstream is then directed upwards, through the openings **800** in the base sidewall **898** of the tray. The air then travels upward into a desiccant tray **74**.

It is further contemplated that the heat exchange assembly **16** and/or the heat exchange assemblies **816** are capable of regulating a temperature within each of their respective housings or trays. Heat exchange assembly **16** or heat exchange assembly **816** may be connected in either serial or parallel distribution configuration. For example, heat exchange assembly **16** or **816** may include a series of temperature regulation valves to control an amount of fluid that flows through heat distribution line. The amount of fluid that flows through a heat distribution line may be proportional to the amount of heat required to warm an airstream within the chamber at specific point in time. For instance, when initiating an extraction cycle, a large delta may exist between a current temperature of an airstream and a desired temperature of an airstream; therefore, a large amount of heat may initially be required to bring the temperature of the airstream, within the chamber, to an optimal or efficient level. By increasing the flow of fluid through heat exchange assembly **16** and/or heat exchange assembly **816**, the heat distribution lines flowing through heat exchange assembly **16** and heat exchange assembly **816** would be able to distribute this larger quantity of heat. Once a desired temperature within the chamber has been reached, the flow through heating line **44** or **844** may then be reduced to maintain the temperature within the chamber and/or the temperature of the airstream. If housing or trays are connected in a serial distribution manner, a bypass valve located near an entrance of each heat exchange assembly **16** or heat exchange assembly **816** may be required.

The flow rate of the fluid, along with the temperature of fluid, impact the temperature of the airstream when pump **70** is recirculation the heating fluid throughout heat exchange assemblies **16** and **816**. Similar to the liquid flow sensor **48** as described above, there may be one or more liquid flow sensors that measure the flow rate of the heating fluid **42** through the various heat exchange assemblies **16** or **816**. The one or more liquid flow sensors may provide a flow rate to the controller **200**; that is, the controller **200** is configured to monitor the flow rate of a fluid **42**. Based in part on the airstream temperature as measured at various locations throughout the desiccant stack **74** and tubing assemblies, fluid pump **70** may be instructed to increase or decrease its output by controller **200** accordingly. Additionally, configurable valves, including fluid bypass valves, may be adjusted to alter a flow rate at a specific location within the device, such as a particular heat exchange assembly. Further, as the heating fluid is circulated, it may be necessary to warm the heating fluid to a desired temperature. Controller **200** may direct the heating source **40** to warm the fluid to a specified temperature in accordance with desired operating conditions.

## 14

In another embodiment, in addition to or in lieu of using heat exchange assembly **16** or **816**, other configurations or devices may be used to add heat to the device or system. For instance, the airstream may be passed through an inline radiator **99** residing in re-circulating line **72**. An inline radiator may further connect to container **45**; with a fluid pump similar to or the same as fluid pump **70** providing a recirculation source of heated fluid **42**.

In another embodiment, multiple energy sources and varying methods of delivering heat may be utilized to add heat to the device **10**. For example, under some operating conditions and in some environments, it may be more efficient to utilize an electric heating element to provide additional heat necessary to increase the temperature of the passing airstream. Such an electrical heating element may be disposed in the heat exchange assembly **16** and may be used instead of heating line **44**. Similarly, an electrical heating element may be disposed in heat exchange assembly **816** and used instead of heating line **844**. When an electrical heating element is utilized in varying configurations, a fluid distribution system, such as fluid container **45**, fluid heater, and fluid distribution piping may not be necessary. Instead, electrical connections are configured to link a power source **40** to the electrical heating element.

In another embodiment, heating elements may be disposed in various places throughout the device **10**. For example, heating element **105** (FIG. 2) may be disposed at both ends of a desiccant media frame **102** and may act more like a forced convection heater. That is, if heating element **105** is an electrical heating element, electricity may pass through the element, warming the surrounding air. Air passing through a desiccant media frame **102** may be warmed. A desiccant media frame **102** may be configured with the necessary electrical connections to operatively connect heating element **105** with a power source, such as power source **40**. Of course, appropriate environmental electrical connections are required when an electric heating element is disposed in close proximity to a desiccant media or if an electric heating element is disposed in a humid or wet environment.

In another embodiment, an electrical heating element(s) may be placed across opening **100**, as shown in FIG. 3. As shown, heating elements **103** warm the airstream passing through openings **100**. Similar to the electrical heating elements **105**, when air passes over heating elements **103**, the passing air, in conjunction with the heating elements, act more like a forced convection heater. That is, electricity passes through the element and warms the surrounding air flowing through openings **100**. In this embodiment and others requiring an electrical connection, an electrical connection is made amongst a stack of desiccant trays such that the necessary electrical energy is provided. For instance, electrical connectors capable of withstanding the environmental conditions located on the top and bottom of a desiccant tray may provide the necessary electrical connections. Alternatively, or in addition, the electrical connections may reside at other locations through the device. Similarly, electrical heating elements **103** may be placed across openings **800**.

In another embodiment, the heat exchange assemblies **16** and **816** are used to provide a consistent airstream temperature within the stack of desiccant media trays, as previously described. However, upon initiating a water extraction cycle, electrical heating elements, such as heating elements **103**, **105**, and **844** may be used to augment or add additional heat to the system as necessary.

Referring to FIG. 9, a preferred embodiment is illustrated for the device **10**. More specifically, a preferred embodiment is illustrated with respect to construction details for the des-



## 15

iccant stack **14**, heat exchanger **16**, and the group air conveying elements including fans, valves, conveying lines, and connectors. More specifically, FIG. **9** illustrates a desiccant stack **14** arranged in a plurality of desiccant trays **74** stacked vertically upon one another over a single heat exchanger assembly **16**. The most upper tray **74** is removed for illustration purposes to shown a sealing gasket **75** that is placed between stacked trays. The stack exhaust manifold **80** is also shown in which airflow from the chamber is returned to the atmosphere through lines **24**. As shown in this embodiment, instead of a single exhaust line **24**, there is a pair of exhaust lines **24** arranged as the outside pair of conveying lines in the group of four adjacent lines. The embodiment of FIG. **9** is intended to illustrate that some of the conveying elements may be provided in duplicate for better airflow control of the device. Accordingly, in addition to duplication of the exhaust lines **24** and associated fans and valves, the FIG. **9** also illustrates duplication of the condenser inlet line **26**, re-circulating line **72**, return line **73**, and the associated valves and fans for these lines. Because of the angle of view in FIG. **9**, another inlet line **20** and associated conveying elements cannot be seen, but the FIG. **8** is intended also to represent that there can also be duplication of these elements. In FIG. **9**, the condenser **28** is shown in a schematic form only, and it shall be understood that the distal free ends of the lines **26** interconnect with the inlet of the coil **30**. Additionally, the FIG. **9** does not illustrate the other components of the condenser as shown in the FIG. **1**, but it shall also be understood that the condenser includes these other elements.

In terms of the modular construction of the device, it is clear that the desiccant trays **74** may be conveniently stacked on top of one another in a space saving arrangement. Additionally, the location of the various fans and valves may be conveniently located adjacent the desiccant stack to maintain a relatively small device profile. The lines for conveying airflow may be a plurality of uniform tubing sections, and the tubing sections may connect to one another by a friction fit. Therefore, it is unnecessary to provide sealing gaskets between each and every tubing section. As discussed in more detail below with respect to the FIGS. **14** and **15**, the modular construction of the invention further allows for friction fit attachments between the sections of tubing and the various valves and fans.

Referring to FIG. **10**, a desiccant stack **14** is illustrated in the same arrangement as shown in the FIG. **9**, but with the various tubing sections, valves, and fans removed. Referring to the FIG. **11**, this vertical cross-sectional clearly illustrates the compact and orderly arrangement of the desiccant trays when placed in a vertical configuration. Although the FIGS. **10** and **11** illustrate a vertical desiccant stack arrangement; it is also contemplated that a desiccant stack could include combinations of both vertically and horizontally extending desiccant trays. Accordingly, with respect to a horizontally extending group of desiccant trays, each of the desiccant trays could also include a tubing manifold **132** in lieu of solid sidewalls **90** and **98** enabling horizontally adjacent trays **74** to communicate with one another by tubing sections interconnecting the trays by their corresponding manifolds **132**. Therefore, one can appreciate the highly configurable nature of the device in terms of adjusting its shape and size for a particular use. For uses of the device with greater water recovery requirements, a larger number of trays can be used to increase water recovery, or uses of the device with lesser water recovery requirements may dictate a fewer number of trays be used. The requisite number of air conveying lines, fans, and valves can be added to a desiccant stack to ensure proper airflow through the device for purposes of both main-

## 16

taining airflow through the device during a charging cycle, as well as airflow through the device during an extraction cycle.

Referring to FIGS. **12** and **13**, in yet another aspect of the invention, it is contemplated that a user may dynamically configure the flow path of air through the device in order to maximize efficiency for the intended use of the device. In the example of FIG. **12**, a parallel flow path is illustrated by the directional arrows in which each of the trays **74** have opposing base sidewalls **98** with openings **100**, which therefore allows airflow to travel upwards in a vertical manner through the chamber and also horizontally through the media cartridges **82**. The only blocked sidewall with no openings **100** is the solid sidewall **180** located above the heat exchanger assembly **16**. This sidewall **180** ensures the air initially passes through the heat exchanger for purposes of heating the air, for example, during an extraction cycle. As shown in the FIG. **11** air may travel horizontally through either a first lower media cartridge, or the media cartridge in the second or next higher tray **74**.

In the example of FIG. **12**, the directional arrows show a torturous or serial flow path that is provided through the chamber of the device. Accordingly, alternating and opposite sidewalls of the stacked desiccant trays **74** include the solid sidewalls **180** without openings **100**. One can appreciate the advantages of the dynamic and modular construction of the present invention in which the trays can be placed not only in various combinations of vertical and horizontal arrangements, but also each tray may be configured with either solid sidewalls **180** or sidewalls **98** with openings **100** in order to establish a desired airflow path through the chamber, and thereby maximizing airflow for the intended use of the device.

Referring now to FIGS. **14** and **15**, an example construction is provided for a valve or damper and fan combination. As shown, in the schematic diagram of FIG. **1**, airflow control through the device includes various pairs of fans and dampers. Accordingly, the FIGS. **14** and **15** are intended to illustrate how these various pairs of fans and dampers may be constructed in accordance with the advantages of the modular construction of the invention. A fan assembly **150** is shown as including a fan housing **158** disposed between a pair of fan flanges **156**. The fan **160** is disposed within the fan housing **158**, and includes a characteristic fan hub, and a plurality of fan blades. A valve assembly **152** connects to the fan assembly. A single connecting flange **162** may be placed between the valve assembly and fan assembly. The construction of the valve assembly **152** may include two half sections, shown as upper half section **164** and lower half section **166**. The flapper or valve element **168** has a mounting pin **170**, which is received in the pin openings **174** of the upper half section **164**. Pin locks **172** may be used to secure the ends of the mounting pin **170**. As also shown in FIG. **13**, an adjacent tubing or conduit section **154** may be secured to the fan also by a single connecting flange **162**. Similarly, the opposite end of the valve assembly **152** may connect to an adjacent tubing section **154** by a single connecting flange **162**. The tubing sections **154** may simply be frictionally received within the adjacent flanges **162**. The half sections **164** and **166** may be secured to the flanges **164** also by a friction fit, as achieved by the flange extensions **176**, or by some other connecting means in which substantial airflow loss is limited between the connections. As also shown, the fan **150** may be secured to its abutting flanges **162** as by a screw and nut combination. The FIGS. **14** and **15** are intended to illustrate an example construction in which pairs of fans and valves may be connected to one another in line with sections of tubing, wherein the construction is simple, reliable, and repeatable without the need for special tools or equipment. Thus, functionally distinct pairs of fans



and valves of the device when installed in the device may be assembled by similar assembly methods.

Additionally, flapper or valve element **168** may be dynamically controlled via an integrated controller **84**.

In order to control the device, an integral controller **84** (FIG. 1) may be used. While manual control is also possible, use of a controller has a number of advantages to include less burdensome user efforts, and more timely and precise control of the device for producing the desired amount of water. The controller **84** may be a known industrial controller, such as a programmable logic controller (PLC).

Referring to the FIG. 16, this figure is intended to represent the controller **84** as a computing device **200** with known functionality. More specifically, FIG. 16 illustrates one embodiment of a computing device **200** comprising hardware elements that may be electrically coupled via a bus **255**. The hardware elements may include one or more central processing units (CPUs) **205**; one or more input devices **210** (e.g., a mouse, a keyboard, etc.); and one or more output devices **215** (e.g., a display device, a printer, etc.). The computing device **200** may also include one or more storage device **220**. By way of example, storage device(s) **220** may be disk drives, optical storage devices, solid-state storage device such as a random access memory ("RAM") and/or a read-only memory ("ROM"), which can be programmable, flash-updateable and/or the like. The controller **200** also includes one or more input/output modules **201**. The input/output modules may be built in with the controller, or may be one or more external input/output modules that plug into the controller. For PLCs, most of these are equipped with extensive input/output module capabilities in which a wide range of inputs and outputs may be accommodated. Further, because PLCs are typically made for severe operating conditions, the use of a PLC as a controller in the device of the invention may be a preferred option.

The computing device **200** may additionally include a computer-readable storage media reader **225**; a communications system **230** (e.g., a modem, a network card (wireless or wired), an infra-red communication device, etc.); and working memory **240**, which may include RAM and ROM devices. Optionally, the computing device **200** may include a processing acceleration unit **235**, which can include a DSP, a special-purpose processor and/or the like. The computer-readable storage media reader **225** can further be connected to a computer-readable storage medium, together (and, optionally, in combination with storage device(s) **220**) comprehensively representing remote, local, fixed, and/or removable storage devices plus storage media for temporarily and/or more permanently containing computer-readable information. The communications system **230** may permit data to be exchanged with a data network and/or with another computing device within a network, as further explained below regarding FIG. 16.

The computing device may also comprise software elements, shown as located within a working memory **240**, including an operating system **245** and/or other code **250**, such as program code implementing a program or code for operation of the device. The computing device **200** may also employ a GPS receiver **260** for location based capabilities. The GPS receiver **260** can be used to further exploit data regarding geographical and/or weather conditions to improve the operational efficiency of device. For example, the GPS receiver can be used to download data regarding orientation and duration of sunlight and the direction(s) of prevailing winds. This data can be used to update or improve the algorithms to obtain better efficiencies for solar energy extraction and to minimize fan power needs. The computing device **200**

may other include a radio transceiver **265** that enables the device to have a wireless communications capability. A particular radio communications protocol may be employed depending upon geographical limitations where the device is installed, enabling the device to maintain wireless communications with a wireless communications network.

Alternate components of the computing device might also be used and/or particular elements might be implemented in hardware, software (including portable software, such as applets), or both. Further, connection to other computing devices such as network input/output devices may be employed.

Although the device has been described with the use of a computing device **200**, it is also contemplated that the device may also be controlled by one or more microcontrollers. A microcontroller is an integrated chip including a central processing unit (CPU), a memory element (such as RAM or ROM), a group of input/output ports, and timers. Microcontrollers, however, are typically designed to execute only a limited number of tasks because of the limited processor capabilities and therefore, are limited in terms of their ability to monitor numerous inputs and to generate numerous command outputs. Nonetheless, because of the relatively few inputs and outputs of the device, a microcontroller in combination with a communications element, such as a transceiver with a wireless capability, remains as a viable solution in terms of providing control for the device.

The computing device or microcontroller(s) may also be incorporated within a communications network, as shown in the FIG. 17. The FIG. 17 is intended to illustrate that either a computing device or microcontroller(s) be represented by the reference numeral **200**. Further, the FIG. 17 is intended to illustrate an example communication system **300** that may be used in connection with the device and method disclosed herein. The system **300** may include one or more remote general purpose computers **305** and **310** that communicate through a communications network **310** with one or more of the devices **10**, each with their own integral controller/microprocessor(s) **200**. By way of example, the general purpose computers may be personal computers and/or laptop computers running various versions of Microsoft Corp.'s Windows™ and/or Apple Corp.'s Macintosh™ operating system(s) and/or workstation computers running any of a variety of commercially-available UNIX™ or UNIX-like operating systems. These remote computers **305** and **310** may also have any of a variety of applications, including for example, database client and/or server applications, and web browser applications. Alternatively, the user computers **305** and **310** may be other electronic devices, such as an Internet-enabled mobile telephone, and/or personal digital assistant, capable of communicating via the network **320** and/or displaying and navigating web pages or other types of electronic documents. Although the exemplary system **300** is shown with two remote computers, any number of remote computers may be supported.

The network **320** may be any type of network familiar to those skilled in the art that can support data communications using any of a variety of commercially-available protocols, including without limitation TCP/IP, SNA, IPX, AppleTalk, and the like. Merely by way of example, the network **320** maybe a local area network ("LAN"), such as an Ethernet network, a Token-Ring network and/or the like; a wide-area network; a virtual network, including without limitation a virtual private network ("VPN"); the Internet; an intranet; an extranet; a public switched telephone network ("PSTN"); an infra-red network; a wireless network (e.g., a network operating under any of the IEEE 802.11 suite of protocols, the



Bluetooth™ protocol known in the art, and/or any other wireless protocol); and/or any combination of these and/or other networks.

The system 300 may also include one or more server computers 325. The server 325 may be a web server, which may be used to process requests for web pages or other electronic documents from user computers 305 and 310. The web server can be running an operating system including any of those discussed above, as well as any commercially-available server operating systems. The web server 325 can also run a variety of server applications, including HTTP servers, FTP servers, CGI servers, database servers, Java servers, and the like. In some instances, the web server 325 may publish operations available as one or more web services.

The system 300 may also include a database 335. The database 335 may reside in a variety of locations. By way of example, database 335 may reside on a storage medium local to (and/or resident in) one or more of the computers 305, 310, or on a storage medium local to one or more of the controllers/microprocessor(s) 200 of the devices 10. Alternatively, the database 335 may be remote from any or all of the computers or controllers, and in communication (e.g., via the network 320) with one or all of the computers and controllers. The database 335 may reside in a storage-area network (“SAN”) familiar to those skilled in the art. Similarly, any necessary files for performing the functions attributed to the computers and/or controllers/microprocessors may be stored remote from or locally on the respective computers or controllers. The database 335 may be a relational database, such as Oracle 10i™, that is adapted to store, update, and retrieve data in response to SQL-formatted commands.

As also shown in the FIG. 17, the controllers/microprocessor(s) 200 each communicate with other components of the system 300 through the network 320. Although the controllers/microprocessors 200 may have the capability to independently operate and control their corresponding devices 10, additional features of the invention may be available when the controllers are incorporated within the communication system 300. For example, if a device is moved from one location to another, the controller could receive updated algorithms that provide more closely matched programming features corresponding to the particular environment in which the devices may operate. Additionally, software or other command updates may be downloaded to the controllers/microprocessors thereby eliminating the need for manual software updates. Additionally, information may be uploaded from the controllers/microprocessors. This information may be used as historical operating data to improve software programming or other aspects of control for the devices. Since the devices may be operating in remote or austere conditions, the capability for the controllers to communicate through a communications network can provide other benefits. For example, if a controller experiences a malfunction or suffers from a reduced functional capacity, it would be possible to bypass control of the device as normally provided by the controller/microcontroller by commands sent through one or more of the remote computers. In the event there are a multitude of devices functioning simultaneously within one or more locations, the computing capability of the server 325 may be advantageous in providing additional or supplemental control to the devices. Additionally, the database 335 can be useful in compiling operational data for the devices in order to improve the sets of algorithms and software commands that may be associated with operation of the devices. Those skilled in the art can appreciate other advantages of incorporating a device 10 within a communication system 300.

In accordance with methods of the present invention, a device removes water vapor from an incoming, ambient airstream. The exhaust airstream leaving the device is therefore a dried or water lean airstream. Operation of the device can conceptually be divided into two main cycles, namely, a charge cycle and an extraction cycle. In the charge cycle, the ambient airstream is passed through a chamber, across a desiccant stack, and back to the environment. The desiccant absorbs water vapor in the air stream. The desiccant is preferably employed in a liquid solution with water. The desiccant solution is distributed in the chamber by a desiccant media, including a plurality of media sheets, preferably in folded media sheets configured within media cartridges disposed in each tray of the desiccant stack.

In accordance with the methods, a charge cycle includes absorption of water vapor, and controlling the amount of water vapor removed from the airstream such that the desiccant solution does not become over saturated with water. In arid climates, it may be advantageous to run the charge cycle during nighttime hours when the relative humidity rises due to a corresponding drop in ambient air temperature. A controlled flow of air is passed through the chamber of the device by one or more fans. As set forth above in the illustrated preferred embodiment, one or more fans may be located at the entrance to the chamber, coupled with one or more fans located at the exit of the chamber. Airflow sensors along with temperature and humidity sensors monitor the state of the chamber. An optimum airflow through the chamber is achieved to match the desired quantity of water to be recovered. If a relatively small amount of water is the recovery requirement, then a smaller volume of air is passed through the chamber as compared to a larger water recovery requirement that must be attained in the same amount of operation time. Once the desiccant media has absorbed the requisite amount of water for the charge cycle, an extraction cycle is commenced. First, the chamber is isolated from the ambient airstream by closing all valves or dampers that communicate with the surrounding environment. Heat energy is added to the chamber. This may be achieved by use of a heat exchanger that has many possible sources of power. Heat energy is added to a predetermined point in which vaporization occurs for the water within the chamber. At this point, the moist air within the chamber can be circulated through a condenser. Preferably, the condenser does not require a separate source of power for cooling. Rather, it is preferred to initiate condensing when the internal temperature within the chamber exceeds a dew point temperature relative to the external ambient temperature. Accordingly, the cooling “source” for the condenser is simply the ambient air, and a flow of ambient air is passed through the condenser to achieve condensing of the moist chamber air. The condenser has a passageway, typically defined by a cooling coil, in which the cooler temperature of the coil causes the water vapor to condense. Water droplets condensed on the surfaces of the condensing coil are collected in a container that communicates with the condensing coil. During this condensing phase of the extraction cycle, heat continues to be added to the chamber for a period of time to evaporate a desired amount of water trapped within the chamber. Accordingly, recirculation of the air within the chamber occurs in which a return line is provided from the condenser back to the chamber. In addition to adding heat to the chamber, the vaporization temperature of the water can be more easily achieved by reducing the pressure within the chamber. For example, a partial vacuum can be drawn for the air within the chamber, and the remaining amount of air within the chamber can be heated and re-circulated during the condensing phase.



Further in accordance with methods of the invention, it is contemplated that optimal desiccant solution ratios are maintained for each reservoir of solution within each tray. Liquid level sensors along with chemical concentration sensors may be employed in each tray to monitor liquid levels and desiccant concentrations. As needed, desiccant solution can be replaced and/or water may be automatically added to each tray as supplied from supply reservoirs that communicate with each of the trays.

Further in accordance with methods of the invention, the dried airstream that is produced during a charge cycle can be used to condition the interior airspace of a man-made structure. Accordingly, duct work may be connected to the exhaust airstream interconnecting the exhaust airstream with the interior airspace.

Also in accordance with methods of the invention, the modular construction of the device allows for easily changing the water recovery capacity of the device. Therefore, it is contemplated that water recovery capability can be optimized by changing the number of trays used by changing the exposed surface area of the media cartridges, and/or changing the flow path of air through the chamber. As discussed, a serial flow path through the chamber or a parallel flow path through the chamber changes the dwell time of the airstream within the chamber. These different flow paths also result in greater or lesser contact of the desiccant media with the airstream which, in turn, alters the rate at which water is absorbed by the desiccant. Additionally, the flow rate of air through the chamber of the device can also be adjusted to meet the desired water recovery requirement. In general, a greater flow rate of air through the chamber should result in a greater amount of water recovered as compared to a lesser flow rate.

Also in accordance with methods of the invention, it is contemplated that dynamic programming is used with a controller/microprocessor to optimize device operation. Within the controller/microprocessor programming, algorithms can be used that establish base line or initial operation parameters based upon known environmental factors. These environmental factors include daily temperature data, daylight data, humidity data, wind data, and potential damage scenario data. Each of these factors may ultimately affect the operation of the device. With respect to temperature and humidity data, this data will partially determine optimum times for operating the cycles of the device. The daylight data also helps to define when temperature and humidity changes will most rapidly occur during average temperature conditions. Wind data can be used to ensure the device is oriented in the proper direction such that a constant flow of air can be provided through the device without undue affects of adverse wind conditions. Potential damage scenarios relate to the specific location where the device is placed, and the chances that a human or environmental event will damage or destroy the device. By evaluating each of these factors as compared to different geographical locations, initial setup and operation of a device is simplified and initially optimized. As a particular device is placed into operation, continued monitoring of environmental conditions along with the operational capability of the device can be used to alter the initial operational algorithms to then establish optimal operational parameters. Because multiple devices may be employed in austere or difficult to travel locations, it is also advantageous to incorporate the devices within a communications network in which operation of the devices may also be controlled remotely. For example, consider a device that has been damaged, or has one or more components that are not functioning to capacity. In this scenario, commands may be issued from a remote computing device to change the current operational algorithms to com-

pensate for the damage to components. One specific example could relate to a component such as a fan or valve that has limited functioning, and therefore, the operational algorithm could be modified to change the operation of these elements in order to meet the desired water recovery goal.

Also in accordance with methods of the present invention, it may be possible to determine the optimum times for running a charge cycle simply by evaluating nighttime hours. For example, light sensors and a time of day clock may be used by the controller to initiate and terminate a charge cycle, the conclusion in this method of control being that nighttime hours are the best for running the charge cycle.

Further in accordance with methods of the invention, it is contemplated that the recovered water may be further treated to ensure it is potable. For example, a number of additional water treatment measures may be taken to make the water potable. Such measures may include filtration, exposure to ultraviolet light, mineralization, chlorination, and/or further chemical treatment.

Further in accordance with methods of the invention, it is contemplated that in lieu of a single heat exchanger, a desiccant stack may take advantage of multiple heat exchanging assemblies powered by a single source of power. Accordingly, selected trays within a desiccant stack may be disposed between one or more heat exchanging assemblies in which each assembly has a heating line, a heat distribution element, and sensors. These assemblies may each have their own housing, or the trays may be modified to incorporate the heat exchanging assemblies in which a single housing can be used for both a desiccant tray and heat exchanging assembly combination.

While illustrative embodiments have been described in detail herein, it is to be understood that the concepts may be otherwise variously embodied and employed, and that the appended claims are intended to be construed to include such variations, except as limited by the prior art.

What is claimed is:

1. A water recovery device comprising:

a desiccant stack including a chamber defining an airflow path therein, the desiccant stack including a plurality of desiccant trays, each desiccant tray including a desiccant media cartridge and an amount of liquid desiccant placed within the desiccant tray and being absorbed by a media material of the media cartridge;

a condenser communicating with the desiccant stack;

a heat source operative to add heat energy to the chamber; and

wherein an airstream within the water recovery device is warmed prior to or during an extraction cycle, the extraction cycle operative to remove a retained water vapor from within the chamber, the condenser providing a cooling source to condense the water vapor and thereby producing an amount of water condensate.

2. A water recovery device, as claimed in claim 1, wherein the heat energy is added to the chamber using a water or glycol-based heat exchanger.

3. A water recovery device, as claimed in claim 2, wherein the heat exchanger further includes a heating element disposed below a heating line, the heating line transferring heat to the heating element, and wherein the heating element is disposed within an airflow path.

4. A water recovery device, as claimed in claim 3, wherein the heating line communicates with a heat source, the heat source configured to regulate a temperature of the heating line such that the temperature of the heating line is increased when the temperature of the heating line falls below a temperature threshold.



5. The water recovery device, as claimed in claim 3, further including an electrical heating element, the electrical heating element adding heat energy to the chamber and being disposed within the defined airflow path of the chamber.

6. The water recovery device, as claimed in claim 5, wherein the electrical heating element and the heat exchanger simultaneously add heat energy to the chamber.

7. A water recovery device recovery device, as claimed in claim 1, wherein the heat source is configured to regulate a temperature of a heating line such that the temperature of the heating line is increased when the temperature of the airstream falls below a temperature threshold.

8. A water recovery device, as claimed in claim 1, wherein an electrical heating element adds heat energy to the chamber, and wherein the electrical heating element is disposed within the defined airflow path of the chamber.

9. A water recovery device, as claimed in claim 8, wherein the electrical heating element is disposed in at least one desiccant tray such that an airflow is warmed prior to flowing past a desiccant media located in the desiccant tray.

10. The water recovery device, as claimed in claim 1, further including an electrical heating element, wherein at least one desiccant tray includes a desiccant media cartridge, the electrical heating element disposed within an airflow path such that an airflow is warmed before passing the desiccant media cartridge.

11. A water recovery system comprising:

(a) a water recovery device including:

(1) a desiccant stack including a chamber defining an airflow path therein, the desiccant stack including a plurality of desiccant trays, each desiccant tray including a desiccant media cartridge and an amount of liquid desiccant placed within the desiccant tray and being absorbed by a media material of the media cartridge;

(2) a condenser communicating with the desiccant stack;

(3) a heat source operative to add heat energy to the desiccant stack;

wherein an airstream within the water recovery device is warmed prior to or during an extraction cycle, the extraction cycle operative to remove a retained water vapor from within the chamber, the condenser providing a cooling source to condense the water vapor and thereby producing an amount of water condensate;

(b) a controller incorporated in the device for controlling functioning of the water recovery device to include an extraction cycle, the water recovery device further including a plurality of sensors as inputs to the controller, and a plurality of valves as outputs of the controller, the valves being located within a heat transport line of the water recovery device; and

(c) a communications node incorporated within a communications system enabling the water recovery device to communicate within the communications system.

12. A water recovery system, as claimed in claim 11, wherein the heat energy is added to the desiccant stack using a water or glycol-based heat exchanger.

13. A water recovery device, as claimed in claim 12, wherein the heat exchanger further includes a heating element disposed below a heating line, the heating line transferring heat to the heating element, and wherein the heating element is disposed within an airflow path.

14. A water recovery device, as claimed in claim 12, wherein an electrical heating element adds heat energy to the desiccant stack, and wherein the electrical heating element is disposed within the defined airflow path of the desiccant stack.

15. The water recovery device, as claimed in claim 14, wherein the electrical heating element and the heat exchanger add heat energy to the desiccant stack simultaneously.

16. A water recovery device, as claimed in claim 11, wherein the heating line communicates with a heat source, the heat source configured to regulate a temperature of the heating line such that the temperature of the heating line is increased when the temperature of the heating line falls below a temperature threshold.

17. The water recovery device, as claimed in claim 11, further including an electrical heating element, the electrical heating element disposed within an airflow path such that an airstream is warmed before passing the desiccant media cartridge.

18. The water recovery device, as claimed in claim 11, further including an electrical heating element, the electrical heating element adding heat energy to the desiccant stack and being disposed within the defined airflow path of the desiccant stack.

\* \* \* \* \*