

US009113999B2

(12) **United States Patent**
Taylor et al.

(10) **Patent No.:** **US 9,113,999 B2**
(45) **Date of Patent:** **Aug. 25, 2015**

(54) **METHODS FOR DEPLOYING A POSITIONING ANCHOR WITH A STENT-GRAFT**

USPC 623/1.11, 1.25, 1.27, 1.28, 1.29, 1.35;
604/103.07, 544, 916, 918; 606/191,
606/192, 194, 198

See application file for complete search history.

(75) Inventors: **Charles S. Taylor**, San Francisco, CA (US); **Christopher Zarins**, Portola Valley, CA (US); **Robert A. Geshlider**, San Francisco, CA (US); **Dwight P. Morejohn**, Davis, CA (US); **Peter Johansson**, Lafayette, CA (US); **Susan W. Vican**, San Francisco, CA (US); **James T. McKinley**, Woodside, CA (US)

(56) **References Cited**

U.S. PATENT DOCUMENTS

4,565,738 A 1/1986 Purdy
4,638,803 A 1/1987 Rand

(Continued)

FOREIGN PATENT DOCUMENTS

DE 4010975 A1 10/1991
EP 95302708.3 11/1995

(Continued)

OTHER PUBLICATIONS

Carmi et al., "Endovascular stent-graft adapted to the endoluminal environment: prototype of a new endoluminal approach," J Endovasc Ther. Jun. 2002;9(3):380-381.

(Continued)

Primary Examiner — Brian Pellegrino

(74) *Attorney, Agent, or Firm* — Kenneth R. Shurtz, Esq.; Kilpatrick Townsend & Stockton LLP

(57) **ABSTRACT**

A positioning anchor is provided for a stent-graft for implantation to treat a damaged body lumen. The positioning anchor is generally tubular surrounding a primary fluid conduit. Arms extend laterally from the generally tubular structure of the anchor surrounding lateral fluid conduits. The form of these arms is preferably custom configured to match a particular patient's luminal geometry. The anchor thus fits within the luminal geometry to remain in a desired fixed position for implantation of the anchor and any stent-graft coupled to the anchor. The anchor is most preferably formed with two walls having a void therebetween which can be filled with fixation media to further secure the anchor at the desired implantation site. A lumen shaper balloon and delivery catheter are also disclosed for proper delivery, expansion and inflation of the positioning anchor and stent-graft elements according to this invention.

21 Claims, 12 Drawing Sheets

(73) Assignee: **Nellix, Inc.**, Irvine, CA (US)

(*) Notice: Subject to any disclaimer, the term of this patent is extended or adjusted under 35 U.S.C. 154(b) by 1985 days.

(21) Appl. No.: **11/876,458**

(22) Filed: **Oct. 22, 2007**

(65) **Prior Publication Data**

US 2008/0039923 A1 Feb. 14, 2008

Related U.S. Application Data

(62) Division of application No. 10/668,901, filed on Sep. 22, 2003, now abandoned.

(60) Provisional application No. 60/412,501, filed on Sep. 20, 2002.

(51) **Int. Cl.**

A61F 2/06 (2013.01)

A61F 2/82 (2013.01)

A61F 2/07 (2013.01)

(52) **U.S. Cl.**

CPC **A61F 2/07** (2013.01); **A61F 2002/061** (2013.01); **A61F 2002/065** (2013.01); **A61F 2002/077** (2013.01); **A61F 2240/002** (2013.01); **A61F 2250/0003** (2013.01)

(58) **Field of Classification Search**

CPC **A61F 2/954**; **A61F 2250/0003**; **A61F 2002/061**; **A61F 2/07**; **A61F 2002/077**

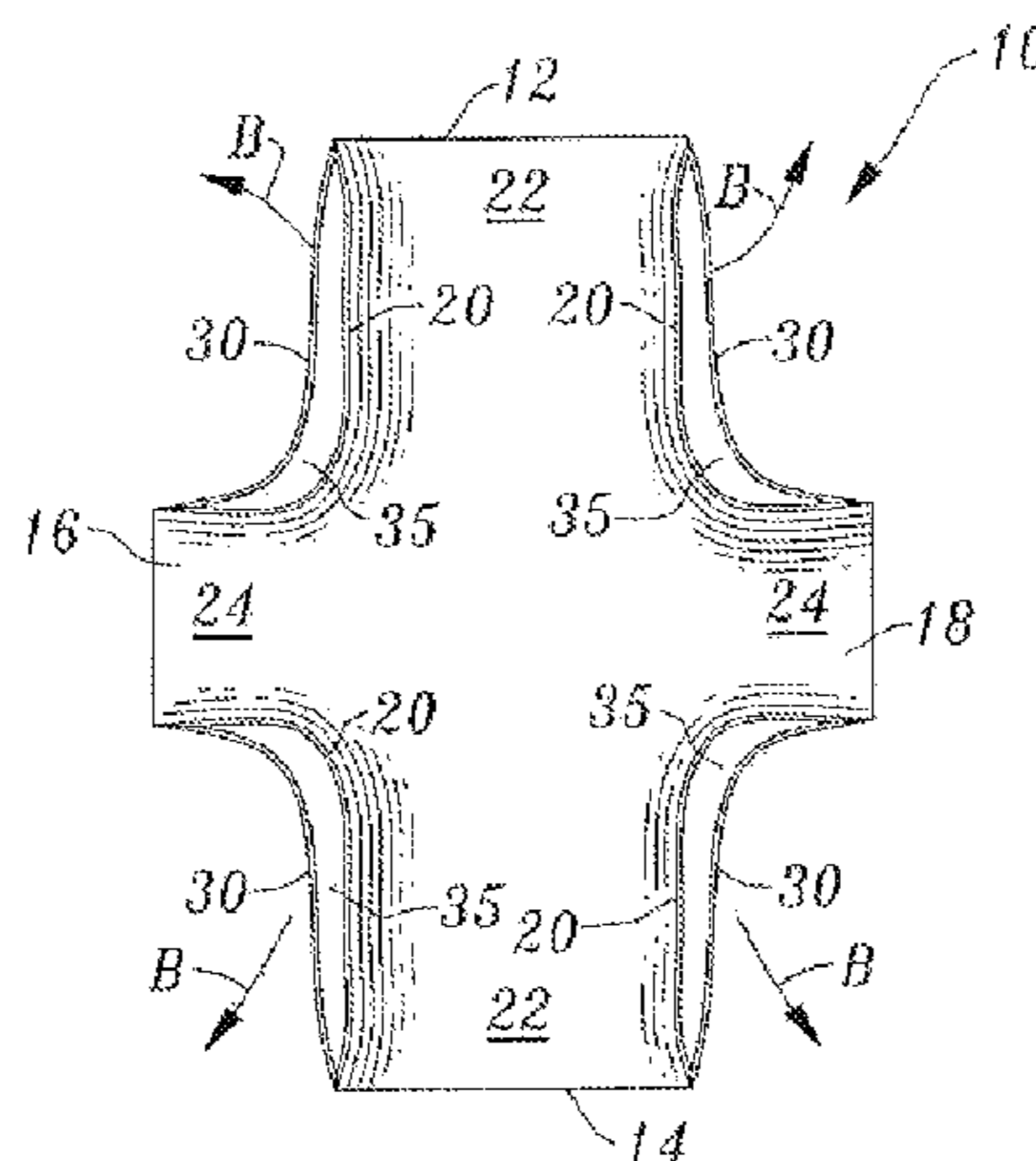

(56)

References Cited

U.S. PATENT DOCUMENTS

4,641,653	A	2/1987	Rockey	5,605,530	A	2/1997	Fischell
4,704,126	A	11/1987	Baswell	5,607,442	A	3/1997	Fischell
4,710,192	A	12/1987	Liotta	5,607,445	A	3/1997	Summers
4,728,328	A	3/1988	Hughes et al.	5,607,468	A	3/1997	Rogers
4,731,073	A	3/1988	Robinson	5,609,605	A	3/1997	Marshall
4,733,665	A	3/1988	Palmaz	5,617,878	A	4/1997	Taheri
4,743,258	A	5/1988	Ikada et al.	5,618,299	A	4/1997	Khosravi
4,763,654	A	8/1988	Jang	5,624,411	A	4/1997	Tuch
4,856,516	A	8/1989	Hillstead	5,630,840	A	5/1997	Mayer
4,858,264	A	8/1989	Reinhart	5,632,760	A	5/1997	Sheiban
4,892,544	A	1/1990	Frisch	5,632,762	A	5/1997	Myler 606/192
4,976,692	A	12/1990	Atad	5,632,763	A	5/1997	Glastra
5,002,532	A	3/1991	Gaiser	5,632,771	A	5/1997	Boatman
5,074,845	A	12/1991	Miraki	D380,266	S	6/1997	Boatman
5,104,404	A	4/1992	Wolff	5,634,941	A	6/1997	Winston
5,108,417	A	4/1992	Sawyer	5,636,641	A	6/1997	Fariabi
5,122,154	A	6/1992	Rhodes	D380,831	S	7/1997	Kavteladze
5,133,732	A	7/1992	Wiktor	5,662,614	A	9/1997	Edoga
5,139,480	A	8/1992	Hickle	5,665,117	A	9/1997	Rhodes
5,156,620	A	10/1992	Pigott	5,674,241	A	10/1997	Bley
5,195,984	A	3/1993	Schatz	5,676,697	A	10/1997	McDonald 623/1.35
5,217,484	A	6/1993	Marks	5,683,449	A	11/1997	Marcade
5,222,970	A	6/1993	Reeves	5,690,643	A	11/1997	WiJay
5,234,437	A	8/1993	Sepetka	5,693,038	A	12/1997	Suzuki et al.
5,242,399	A	9/1993	Lau	5,693,067	A	12/1997	Purdy
5,250,071	A	10/1993	Palermo	5,693,088	A	12/1997	Lazarus
5,261,916	A	11/1993	Engelson	5,697,971	A	12/1997	Fischell
5,263,964	A	11/1993	Purdy	5,709,707	A	1/1998	Lock
5,292,331	A	3/1994	Houki et al.	5,718,713	A	2/1998	Frantzen
5,314,444	A	5/1994	Gianturco	5,723,004	A	3/1998	Dereume
5,316,023	A	5/1994	Palmaz et al.	5,725,568	A	3/1998	Hastings
5,330,528	A	7/1994	Lazim	5,725,572	A	3/1998	Lam
5,334,217	A	8/1994	Das	5,728,068	A	3/1998	Leone
5,350,397	A	9/1994	Palermo	5,728,131	A	3/1998	Frantzen
5,352,199	A	10/1994	Tower	5,728,158	A	3/1998	Lau
5,375,612	A	12/1994	Cottenceau	5,733,303	A	3/1998	Israel et al.
5,383,892	A	1/1995	Cardon	5,735,892	A	4/1998	Myers
5,421,955	A	6/1995	Lau	5,735,893	A	4/1998	Lau
5,423,849	A	6/1995	Engelson	5,741,327	A	4/1998	Frantzen
5,425,739	A	6/1995	Jessen	5,741,333	A	4/1998	Frid
5,425,744	A	6/1995	Fagan	5,746,691	A	5/1998	Frantzen
5,441,510	A	8/1995	Simpson	5,755,769	A	5/1998	Richard
5,441,515	A	8/1995	Khosravi	5,755,773	A	5/1998	Evans et al.
5,443,477	A	8/1995	Marin	5,755,778	A	5/1998	Kleshinski
5,443,496	A	8/1995	Schwartz	5,766,151	A	6/1998	Valley et al.
5,449,373	A	9/1995	Pinchasik	5,766,238	A	6/1998	Lau
5,485,667	A	1/1996	Kleshinski	5,769,882	A	6/1998	Fogarty et al.
5,494,029	A	2/1996	Lane et al.	5,776,114	A	7/1998	Frantzen
5,496,277	A	3/1996	Termin	5,776,161	A	7/1998	Globerman
5,507,767	A	4/1996	Maeda	5,782,907	A	7/1998	Frantzen
5,507,769	A	4/1996	Marin et al.	5,785,679	A	7/1998	Abolfathi et al.
5,507,771	A	4/1996	Gianturco	5,788,626	A	8/1998	Thompson
5,514,115	A	5/1996	Frantzen	5,797,953	A	8/1998	Tekulve
5,514,154	A	5/1996	Lau	5,800,393	A	9/1998	Sahota
5,522,882	A	6/1996	Gaterud	5,800,512	A	9/1998	Lentz et al.
5,531,741	A	7/1996	Barbacci	5,800,514	A	9/1998	Nunez
5,534,024	A	7/1996	Rogers et al.	5,800,525	A	9/1998	Bachinski
5,545,210	A	8/1996	Hess	5,807,404	A	9/1998	Richter
5,549,662	A	8/1996	Fordenbacher	5,810,872	A	9/1998	Kanesaka
5,549,663	A	8/1996	Cottone, Jr.	5,824,036	A	10/1998	Lauterjung
5,554,181	A	9/1996	Das	5,824,037	A	10/1998	Fogarty et al.
5,562,641	A	10/1996	Flomenblit	5,824,040	A	10/1998	Cox
5,562,698	A	10/1996	Parker	5,824,049	A	10/1998	Ragheb
5,562,728	A	10/1996	Lazarus	5,824,054	A	10/1998	Khosravi et al.
5,569,295	A	10/1996	Lam	5,824,056	A	10/1998	Rosenberg
5,578,074	A	11/1996	Mirigian	5,827,321	A	10/1998	Roubin
5,578,149	A	11/1996	De Scheerder	5,836,966	A	11/1998	St. Germain
5,591,195	A	1/1997	Taheri	5,843,160	A	12/1998	Rhodes
5,591,223	A	1/1997	Lock	5,843,175	A	12/1998	Frantzen
5,591,226	A	1/1997	Trerotola	5,846,246	A	12/1998	Dirks
5,591,228	A	1/1997	Edoga	5,846,261	A	12/1998	Kotula et al.
5,591,230	A	1/1997	Horn	5,849,037	A	12/1998	Frid
5,593,417	A	1/1997	Rhodes	5,860,998	A	1/1999	Robinson
5,601,600	A	2/1997	Ton	5,863,627	A	1/1999	Szycher
5,603,721	A	2/1997	Lau	5,867,762	A	2/1999	Rafferty et al.
				5,868,685	A	2/1999	Powell et al.
				5,868,708	A	2/1999	Hart
				5,868,782	A	2/1999	Frantzen
				5,871,537	A	2/1999	Holman

(56)

References Cited

U.S. PATENT DOCUMENTS

5,873,907 A	2/1999	Frantzen	6,592,614 B2	7/2003	Lenker et al.
5,876,448 A	3/1999	Thompson et al.	6,613,037 B2	9/2003	Khosravi et al.
5,879,381 A	3/1999	Moriuchi	6,645,242 B1	11/2003	Quinn
5,888,660 A	3/1999	Landoni et al.	6,656,214 B1	12/2003	Fogarty et al.
5,902,332 A	5/1999	Schatz	6,656,220 B1	12/2003	Gomez et al.
5,919,224 A	7/1999	Thompson	6,663,607 B2	12/2003	Slaikou et al.
5,928,279 A	7/1999	Shannon et al.	6,663,667 B2	12/2003	Dehdashtian et al.
5,931,866 A	8/1999	Frantzen	6,679,300 B1	1/2004	Sommer et al.
5,944,750 A	8/1999	Tanner	6,682,546 B2	1/2004	Amplatz
5,947,991 A	9/1999	Cowan	6,692,486 B2	2/2004	Jaafar et al.
5,948,184 A	9/1999	Frantzen	6,695,833 B1	2/2004	Frantzen et al.
5,976,178 A	11/1999	Goldsteen et al.	6,729,356 B1	5/2004	Baker et al.
5,984,955 A	11/1999	Wisselink	6,730,119 B1	5/2004	Smalling
5,994,750 A	11/1999	Yagi	6,733,521 B2	5/2004	Chobotov
6,007,573 A	12/1999	Wallace	6,761,733 B2	7/2004	Chobotov
6,015,431 A	1/2000	Thornton	6,773,454 B2	8/2004	Wholey et al.
6,022,359 A	2/2000	Frantzen	6,776,771 B2	8/2004	Van Moorlegem et al.
6,033,434 A	3/2000	Borghia	6,827,735 B2	12/2004	Greenberg
6,042,606 A	3/2000	Frantzen	6,843,803 B2	1/2005	Ryan et al.
6,056,776 A	5/2000	Lau	6,878,161 B2	4/2005	Lenker
6,066,167 A	5/2000	Lau	6,878,164 B2	4/2005	Kujawski
6,066,168 A	5/2000	Lau	6,887,268 B2	5/2005	Butaric et al.
6,083,259 A	7/2000	Frantzen	6,918,926 B2	7/2005	Letort
6,093,199 A	7/2000	Brown	6,945,989 B1	9/2005	Betelia et al.
6,099,548 A	8/2000	Taheri	6,958,051 B2	10/2005	Hart et al.
6,110,198 A	8/2000	Fogarty et al.	6,960,227 B2	11/2005	Jones et al.
6,123,715 A	9/2000	Amplatz	7,022,100 B1	4/2006	Aboul-Hosn et al.
6,123,722 A	9/2000	Fogarty	7,105,012 B2	9/2006	Trout, III
6,124,523 A	9/2000	Banas et al.	7,112,217 B1	9/2006	Kugler
6,132,457 A	10/2000	Chobotov	7,122,052 B2	10/2006	Greenhalgh
6,152,144 A	11/2000	Lesh	7,131,991 B2	11/2006	Zarins et al.
6,152,943 A	11/2000	Sawhney	7,147,661 B2	12/2006	Chobotov et al.
6,168,592 B1	1/2001	Kupiecki et al.	7,175,652 B2	2/2007	Cook et al.
6,187,033 B1	2/2001	Schmitt	7,229,472 B2	6/2007	DePalma et al.
6,187,034 B1	2/2001	Frantzen	7,314,483 B2	1/2008	Landau et al.
6,190,402 B1	2/2001	Horton et al.	7,326,237 B2	2/2008	Depalma et al.
6,190,406 B1	2/2001	Horton et al.	7,435,253 B1	10/2008	Hartley et al.
6,193,745 B1	2/2001	Fogarty et al.	7,530,988 B2	5/2009	Evans et al.
6,196,230 B1	3/2001	Hall et al.	7,666,220 B2	2/2010	Evans et al.
6,203,732 B1	3/2001	Clubb	7,682,383 B2	3/2010	Robin
6,214,022 B1	4/2001	Taylor et al.	7,708,773 B2	5/2010	Pinchuk et al.
6,231,562 B1	5/2001	Khosravi et al.	7,790,273 B2	9/2010	Lee et al.
6,235,050 B1	5/2001	Quiachon et al.	7,828,838 B2	11/2010	Bolduc et al.
6,241,761 B1	6/2001	Villafana	7,951,448 B2	5/2011	Lee et al.
6,254,633 B1	7/2001	Pinchuk et al.	2001/0020184 A1	9/2001	Dehdashtian et al.
6,261,305 B1	7/2001	Marotta	2001/0027337 A1	10/2001	Robin
6,280,466 B1	8/2001	Kugler	2001/0027338 A1	10/2001	Greenberg
6,283,991 B1	9/2001	Cox et al.	2001/0044655 A1	11/2001	Patnaik et al.
6,290,722 B1	9/2001	Wang	2002/0019665 A1	2/2002	Dehdashtian et al.
6,290,731 B1	9/2001	Solovay et al.	2002/0026217 A1	2/2002	Baker et al.
6,293,960 B1	9/2001	Ken	2002/0045848 A1	4/2002	Jaafar et al.
6,296,603 B1	10/2001	Turnlund et al.	2002/0045931 A1	4/2002	Sogard et al.
6,299,597 B1	10/2001	Buscemi et al.	2002/0052643 A1	5/2002	Wholey et al.
6,299,604 B1	10/2001	Ragheb	2002/0077594 A1	6/2002	Chien et al.
6,312,462 B1	11/2001	McDermott	2002/0151953 A1	10/2002	Chobotov
6,312,463 B1	11/2001	Rourke et al.	2002/0151956 A1	10/2002	Chobotov
6,325,816 B1	12/2001	Fulton, III	2002/0151958 A1	10/2002	Chuter
6,325,819 B1	12/2001	Pavcnik et al.	2002/0156518 A1*	10/2002	Tehrani 623/1.35
6,331,184 B1	12/2001	Abrams	2002/0165521 A1	11/2002	Cioanta et al.
6,331,191 B1	12/2001	Chobotov	2002/0169497 A1	11/2002	Wholey et al.
6,334,869 B1	1/2002	Leonhardt et al.	2002/0183629 A1	12/2002	Fitz
6,344,056 B1	2/2002	Dehdashtian	2003/0004560 A1	1/2003	Chobotov
6,375,675 B2	4/2002	Dehdashtian et al.	2003/0009132 A1	1/2003	Schwartz et al.
6,395,019 B2	5/2002	Chobotov	2003/0014075 A1	1/2003	Rosenbluth et al.
6,409,757 B1	6/2002	Trout, III et al.	2003/0028209 A1	2/2003	Teoh et al.
6,432,131 B1	8/2002	Ravenscroft	2003/0036745 A1	2/2003	Khosravi et al.
6,451,047 B2	9/2002	McCrea	2003/0051735 A1	3/2003	Pavcnik et al.
6,463,317 B1	10/2002	Kucharczyk et al.	2003/0074056 A1	4/2003	Killion et al.
6,506,204 B2	1/2003	Mazzocchi	2003/0078647 A1	4/2003	Vallana et al.
6,527,799 B2	3/2003	Shanley	2003/0093145 A1	5/2003	Lawrence-Brown et al.
6,544,276 B1	4/2003	Azizi	2003/0130720 A1	7/2003	DePalma et al.
6,547,804 B2	4/2003	Porter et al.	2003/0130725 A1	7/2003	DePalma et al.
6,554,858 B2	4/2003	Dereume et al.	2003/0135269 A1	7/2003	Swanstrom
6,576,007 B2	6/2003	Dehdashtian et al.	2003/0204242 A1	10/2003	Zarins et al.
6,579,301 B1	6/2003	Bales	2003/0204249 A1	10/2003	Letort
			2003/0216802 A1	11/2003	Chobotov et al.
			2003/0220649 A1	11/2003	Bao et al.
			2003/0225446 A1	12/2003	Hartley
			2004/0016997 A1	1/2004	Ushio

(56)

References Cited

U.S. PATENT DOCUMENTS

2004/0044358	A1	3/2004	Khosravi et al.
2004/0082989	A1	4/2004	Cook et al.
2004/0091543	A1	5/2004	Bell et al.
2004/0098096	A1	5/2004	Eton
2004/0116997	A1	6/2004	Taylor et al.
2004/0147811	A1	7/2004	Diederich et al.
2004/0153025	A1	8/2004	Seifert et al.
2004/0167607	A1	8/2004	Frantzen
2004/0193245	A1	9/2004	Deem et al.
2004/0204755	A1	10/2004	Robin
2004/0215172	A1	10/2004	Chu et al.
2004/0215316	A1	10/2004	Smalling
2004/0220522	A1	11/2004	Briscoe et al.
2004/0243057	A1	12/2004	Vinten-Johansen et al.
2005/0004660	A1	1/2005	Rosenbluth et al.
2005/0027238	A1	2/2005	Fago et al.
2005/0028484	A1	2/2005	Littlewood
2005/0065592	A1	3/2005	Holzer
2005/0090804	A1	4/2005	Chobotov et al.
2005/0096731	A1	5/2005	Looietal
2005/0215989	A1	9/2005	Abboud et al.
2005/0245891	A1	11/2005	McCormick et al.
2005/0251251	A1	11/2005	Cribier
2006/0015173	A1	1/2006	Clifford et al.
2006/0025853	A1	2/2006	Evans et al.
2006/0074481	A1	4/2006	Vardi et al.
2006/0135942	A1	6/2006	Fernandes et al.
2006/0142836	A1	6/2006	Hartley et al.
2006/0155369	A1	7/2006	Edwin et al.
2006/0161244	A1	7/2006	Seguin
2006/0184109	A1	8/2006	Gobel
2006/0206197	A1	9/2006	Morsi
2006/0212112	A1	9/2006	Evans et al.
2006/0265043	A1	11/2006	Mandrusov et al.
2006/0292206	A1	12/2006	Kim et al.
2007/0032850	A1	2/2007	Ruiz et al.
2007/0043420	A1	2/2007	Lostetter
2007/0050008	A1	3/2007	Kim et al.
2007/0055355	A1	3/2007	Kim et al.
2007/0061005	A1	3/2007	Kim et al.
2007/0150041	A1	6/2007	Evans et al.
2007/0162109	A1	7/2007	Davila et al.
2007/0208416	A1	9/2007	Burpee et al.
2007/0276477	A1	11/2007	Lee et al.
2008/0039923	A1	2/2008	Taylor et al.
2008/0154368	A1	6/2008	Justis et al.
2008/0228259	A1	9/2008	Chu
2008/0294237	A1	11/2008	Chu
2009/0099649	A1	4/2009	Chobotov et al.
2009/0198267	A1	8/2009	Evans et al.
2009/0209855	A1	8/2009	Drilling et al.
2009/0216125	A1	8/2009	Lenker
2009/0318949	A1	12/2009	Ganpath et al.
2009/0319029	A1	12/2009	Evans et al.
2010/0004728	A1	1/2010	Rao et al.
2010/0036360	A1	2/2010	Herbowy et al.
2010/0106087	A1	4/2010	Evans et al.
2010/0217383	A1	8/2010	Leonhardt et al.
2012/0016456	A1	1/2012	Herbowy et al.

FOREIGN PATENT DOCUMENTS

EP	1325717	7/2003
EP	1903985	4/2008
FR	2834199	A1 7/2003
JP	4-322665	A 11/1992
JP	2003-525692	9/2003
JP	2004-537353	A 12/2004
JP	2005-505380	A 2/2005
JP	2005-532120	A 10/2005
JP	2008-510502	A 4/2008
WO	97/17912	A1 5/1997
WO	97/19653	6/1997
WO	98/53761	A1 12/1998

WO	99/00073	A1 1/1999
WO	99/44539	A2 9/1999
WO	00/29060	A2 5/2000
WO	WO 00/51522	9/2000
WO	WO 01/21108	3/2001
WO	01/66038	9/2001
WO	WO 01/66038	9/2001
WO	02/078569	A2 10/2002
WO	02/083038	A2 10/2002
WO	WO 02/102282	12/2002
WO	03/007785	A2 1/2003
WO	03/032869	A1 4/2003
WO	03/037222	A2 5/2003
WO	03/053288	A1 7/2003
WO	2004/004603	A1 1/2004
WO	2004/026183	A2 4/2004
WO	2004/026183	A3 4/2004
WO	2004/037116	A2 5/2004
WO	2004/037116	A3 5/2004
WO	WO 2004/045393	A2 6/2004
WO	2006/012567	A2 2/2006
WO	2006/012567	A3 2/2006
WO	2006/116725	A2 11/2006
WO	2007/008600	A2 1/2007
WO	2007/142916	A2 12/2007

OTHER PUBLICATIONS

Gilling-Smith, "Stent Graft Migration After Endovascular Aneurysm Repair," presented at 25th International Charing Cross Symposium, Apr. 13, 2003 [Power Point Presentation and Transcript], 56 pages total.

Patrick W. Serruys and Michael JB Kutryk; Handbook of Coronary Stents, Second Edition; 1998; pp. 45, 55, 78, 103, 112, 132, 158, 174, 185, 190, 207, 215, 230, 239; Martin Dunitz; UK.

Journal of Endovascular Therapy; Apr. 2000; pp. 111, 114, 132-140; vol. 7th No. 2; International Society of Endovascular Specialists; Phoenix, AZ.

Donayre et al., "Fillable Endovascular Aneurysm Repair," Endovascular Today, pp. 64-66, Jan. 2009.

International Search Report and Written Opinion of PCT Application No. PCT/US2009/046310, dated Jul. 29, 2009, 9 pages total.

International Search Report of PCT/US 06/16403, dated Aug. 7, 2007. 2 pages.

International Search Report and Written Opinion of PCT Application No. PCT/US2006/062257, mailed Jan. 18, 2008. 7 pages total.

International Search Report and Written Opinion of PCT Application No. PCT/US07/69671, dated Jul. 7, 2008, 9 pages.

International Search Report and Written Opinion of PCT Application No. PCT/US09/34136, D dated Apr. 8, 2009, 16 pages total.

U.S. Appl. No. 12/371,087, filed Feb. 13, 2009, first named inventor: K.T. Venkateswara Rao.

International Search Report and Written Opinion of PCT Application No. PCT/US09/41718, dated Jun. 22, 2009, 23 pages total.

Supplementary European Search Report and Search Opinion of EP Patent Application No. 05773726, mailed Apr. 23, 2010, 6 pages total.

International Search Report and The Written Opinion of The International Searching Authority, Issued in PCT/US2012/032612 on Jul. 25, 2012, 13 pages.

International Search Report of the International Searching Authority for Application No. PCT/US2012/021878, mailed on May 23, 2012, 4 pages.

Written Opinion, including search, of the International Searching Authority for Application No. PCT/US2012/021878, mailed May 23, 2012, 9 pages.

Extended European search report of corresponding EP Application No. 06751879.5, dated Apr. 16, 2013. 9 pages.

European Search Report and Search Opinion of EP Patent Application No. 06774540.6, mailed Mar. 30, 2010, 6 pages total.

EP report, dated Nov. 7, 2013, of corresponding EP Application No. 09733719.0.

Search report dated Oct. 17, 2013 of corresponding PCT/US2012/032612.

(56)

References Cited

OTHER PUBLICATIONS

International Preliminary Report on Patentability PCT/US2012/021878 dated Aug. 1, 2013.

Report of European Patent Application No. 06850439.8 dated May 15, 2013.

Report for European Patent Application No. 06850439.8, dated Aug. 8, 2012.

Examination report for JP Application. No. 2008-547709 dated Dec. 13, 2011.

International Search Report and Written Opinion of PCT Application No. PCT /US2009/046308, mailed Nov. 17, 2009, 12 pages total.

Examination Report of corresponding Japanese Application No. 2011-512667, dated Jun. 18, 2013.

International Preliminary Report on Patentability and Written Opinion of The International Searching Authority, Issued in PCT/US2010/061621 on Jul. 12, 2012, 7 pages.

PCT International Search Report and Written Opinion dated Feb. 28, 2011 for PCT Application No. PCT/US2010/61621. 11 pages.

U.S. Appl. No. 60/855,889, filed Oct. 31, 2006; first named inventor: Steven L. Herbowy.

U.S. Appl. No. 12/429,474, filed Apr. 24, 2009; first named inventor: Steven L. Herbowy.

U.S. Appl. No. 61/052,059, filed May 9, 2008; first named inventor: Gwendolyn A. Watanabe.

William Tanski, Mark Fillinger. *Outcomes of original and low-permeability Gore Excluder endoprosthesis for endovascular abdominal aortic aneurysm repair*. Journal of Vascular Surgery. Feb. 2007. p. 243-249.

Susan M. Trocciola et al. The development of endotension is associated with increased transmission of pressure and serous components

in porous expanded polytetrafluoroethylene stent-grafts: Characterization using a canine model. Journal of Vascular Surgery. Jan. 2006. p. 109-116.

Shan-e-ali Haider et al. Sac behavior after aneurysm treatment with the Gore Excluder low-permeability aortic endoprosthesis: 12-month comparison to the original Excluder device. Journal of Vascular Surgery. vol. 44, No. 4. 694-700. Oct. 2006.

Examination report of EP Application No. 06751879.5, dated Mar. 24, 2014. 5 pages.

Examination Report of Japanese Patent Application No. 2007-522822, dated Feb. 8, 2011.

Examination Report of Japanese Patent Application No. 2011-506487, dated Jun. 11, 2013.

Official Action for Japanese Patent Application No. 2008-547709, dated Oct. 30, 2012.

Examination Report of Japanese Patent Application No. 2008-547709, dated Jul. 22, 2013.

Examination Report of European Patent Application 03754880.7; dated Dec. 16, 2010.

Examination Report of European Patent Application 03754880.7; dated Dec. 22, 2011.

Examination Report of European App. 03754880.7, dated Feb. 22, 2013.

Examination Report of European Application No. 03754880.7; dated Jun. 29, 2012. 4 pages.

Extended European Search Report of Application No. 11180827.5, dated Jan. 30, 2012. 6 pages.

Search report of corresponding PCT/US2014/021928, mailed May 20, 2014. 8 pages.

Examination Report of Japanese Patent Application No. 2011-506487, dated May 7, 2014.

* cited by examiner

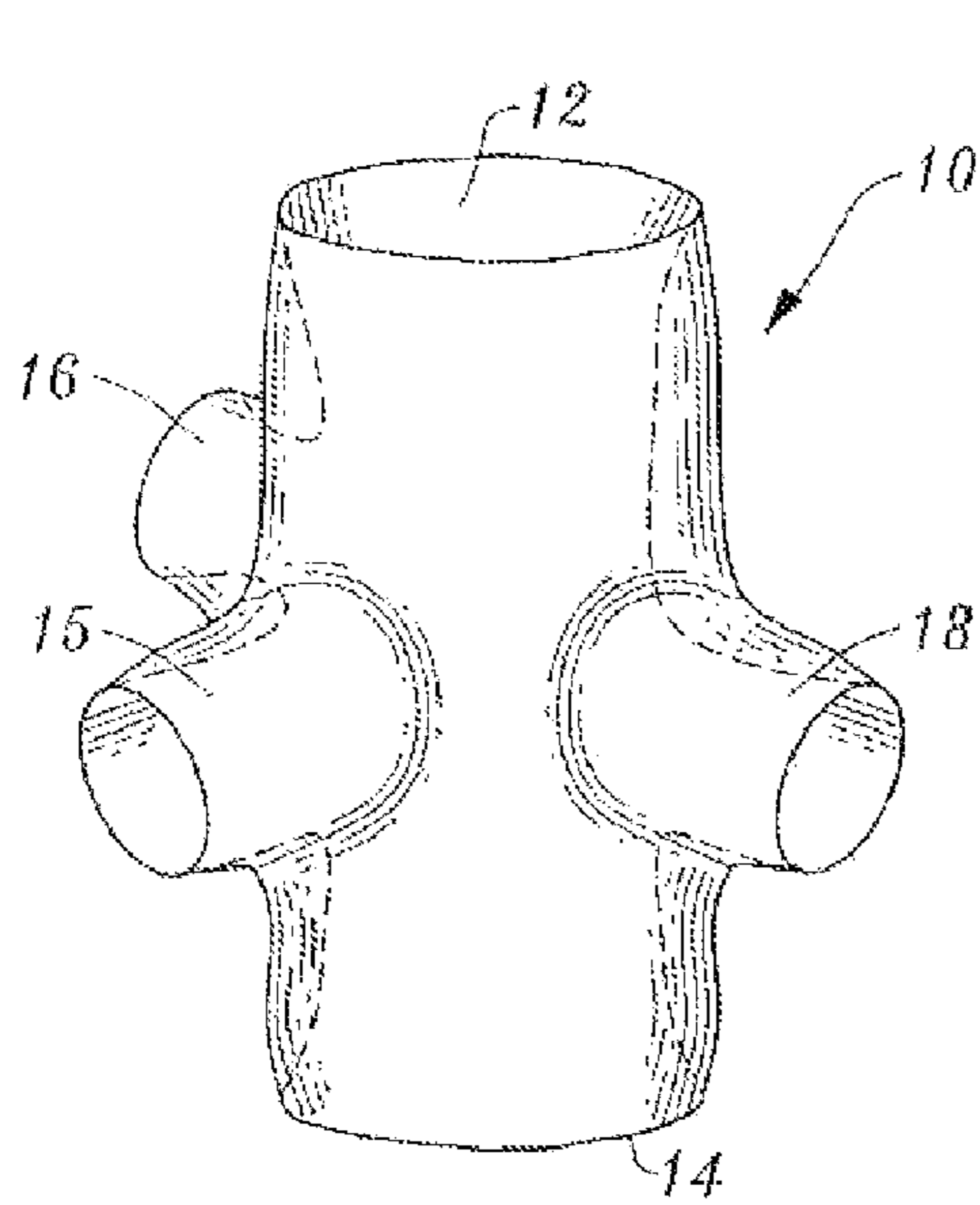

Fig. 1

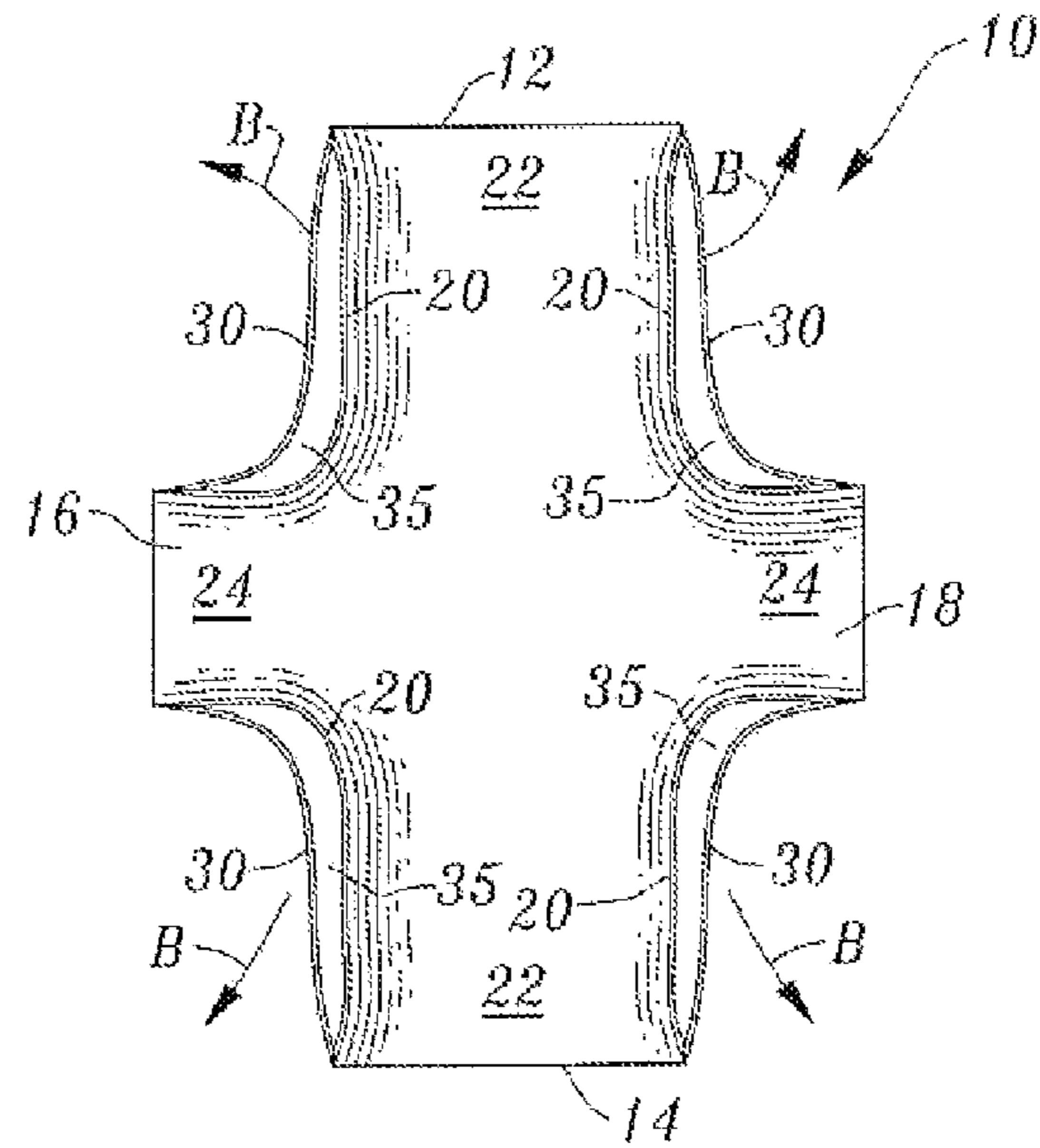

Fig. 2

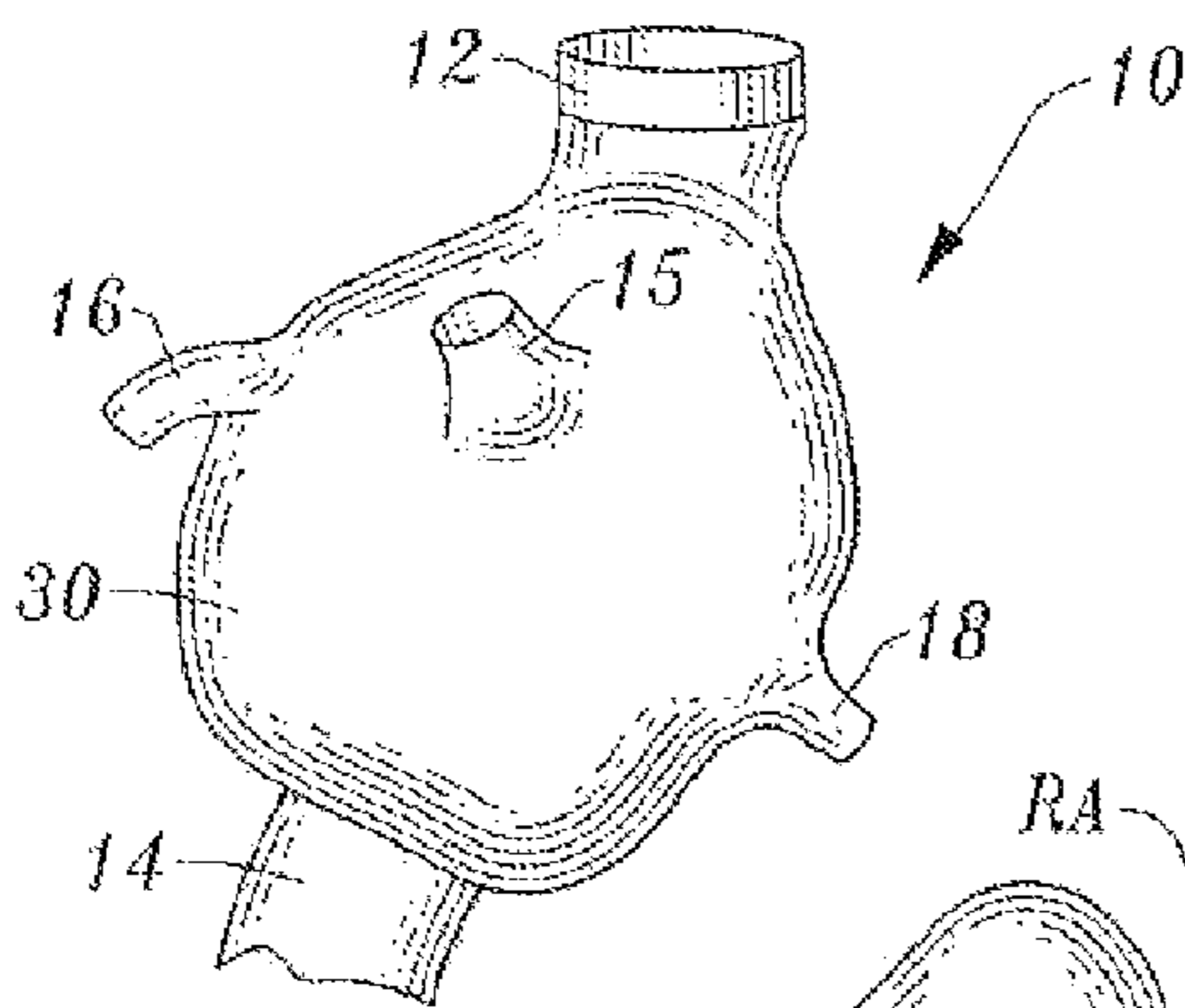

Fig. 3

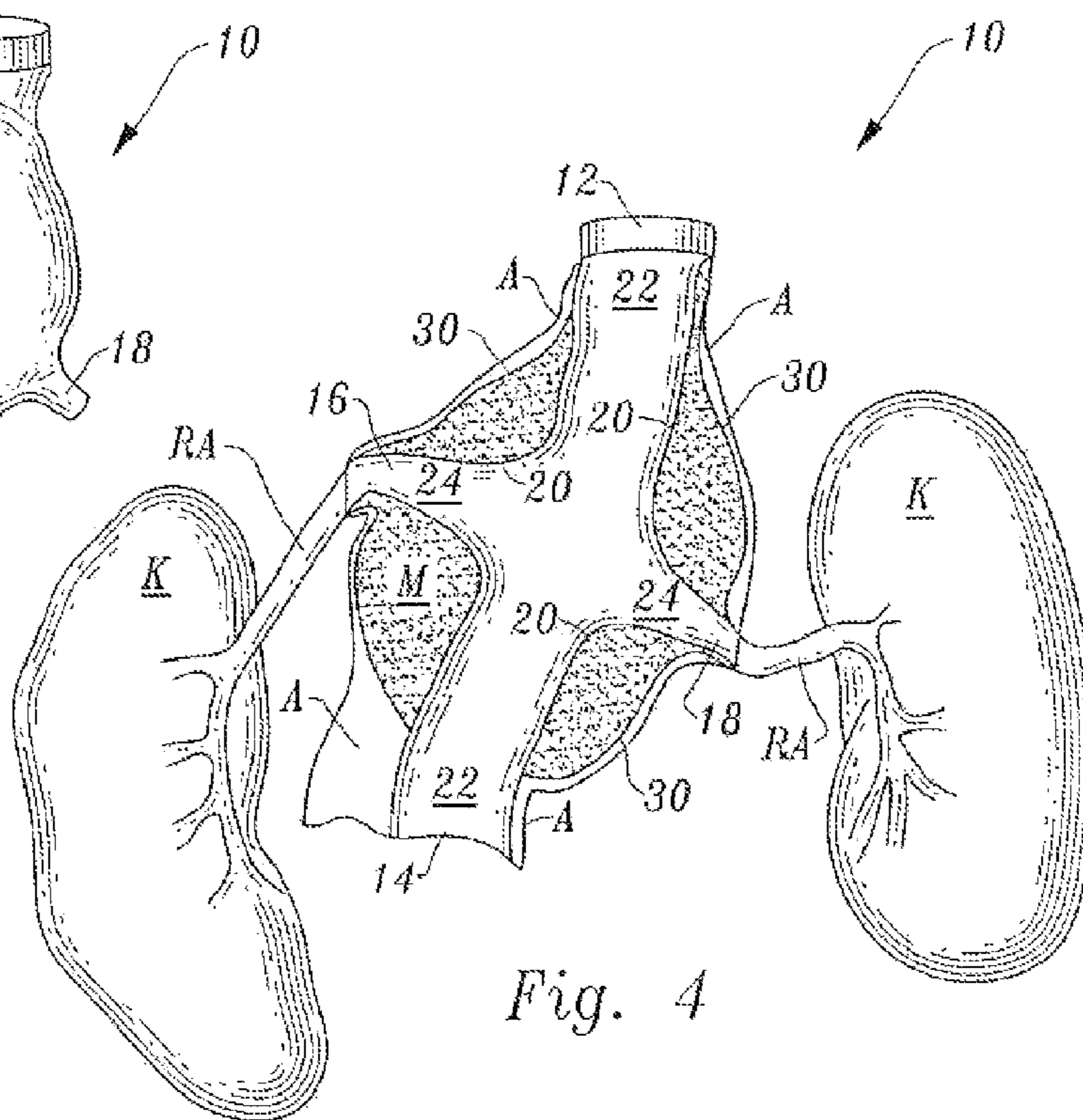

Fig. 4

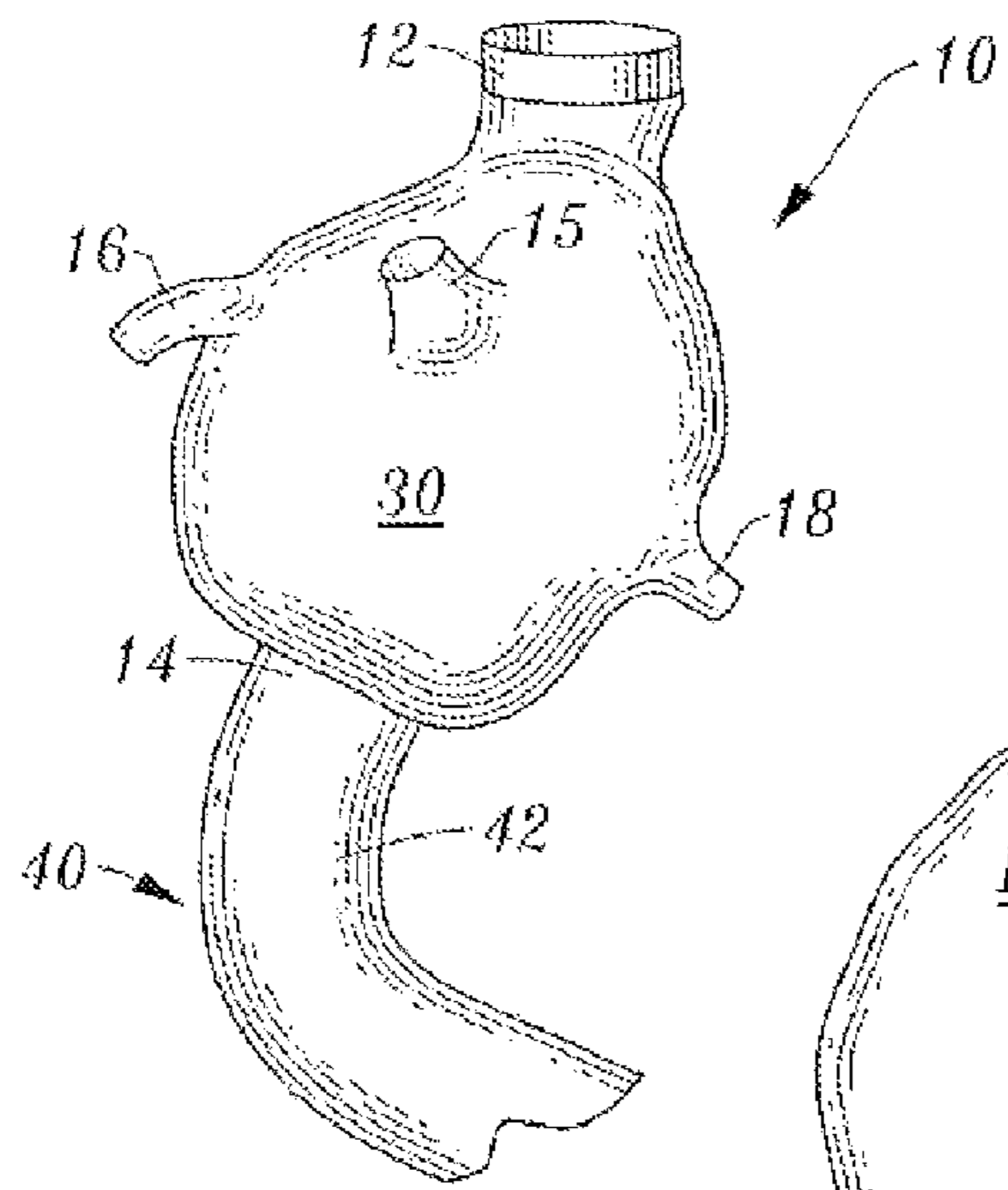

Fig. 5

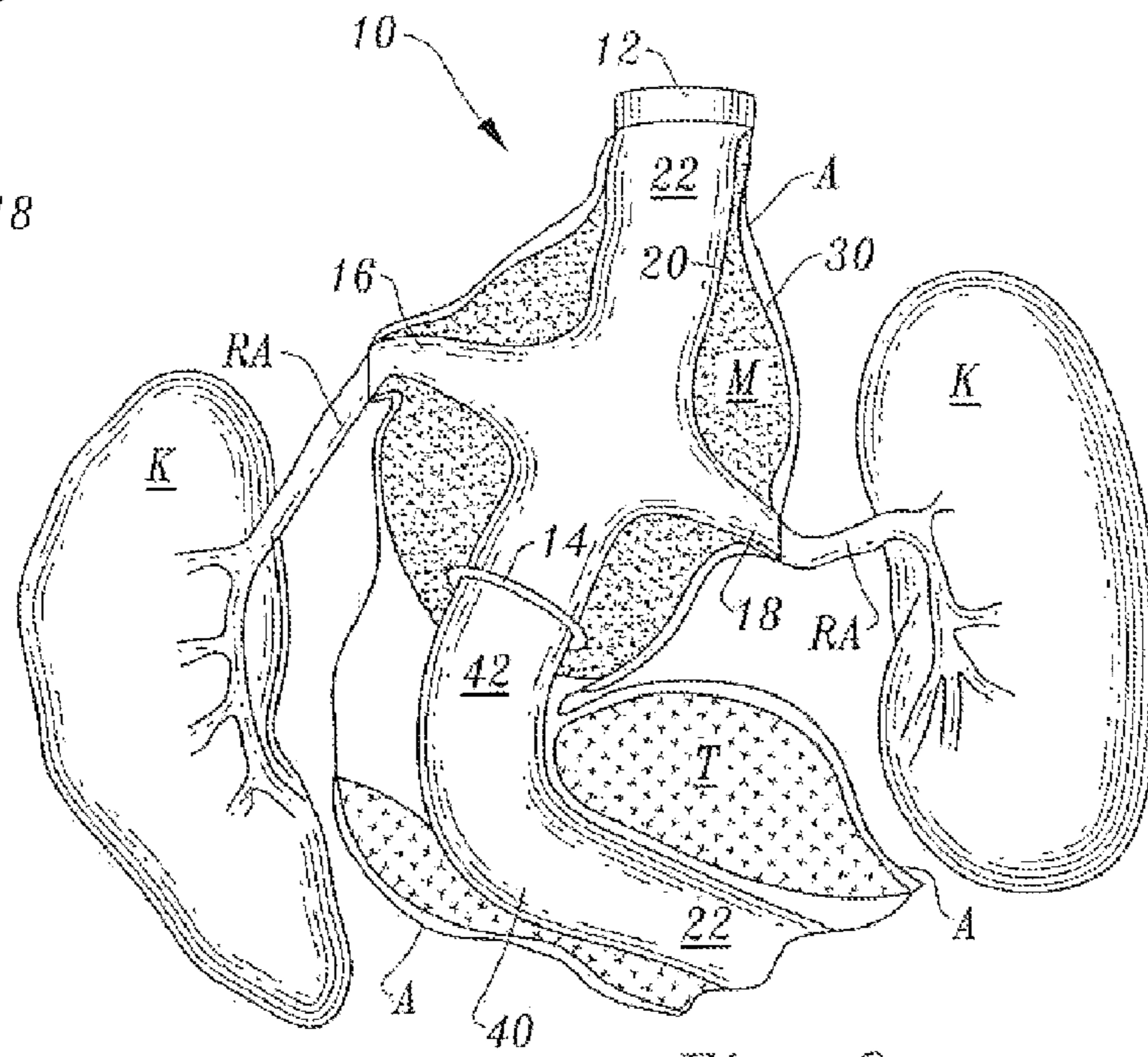

Fig. 6

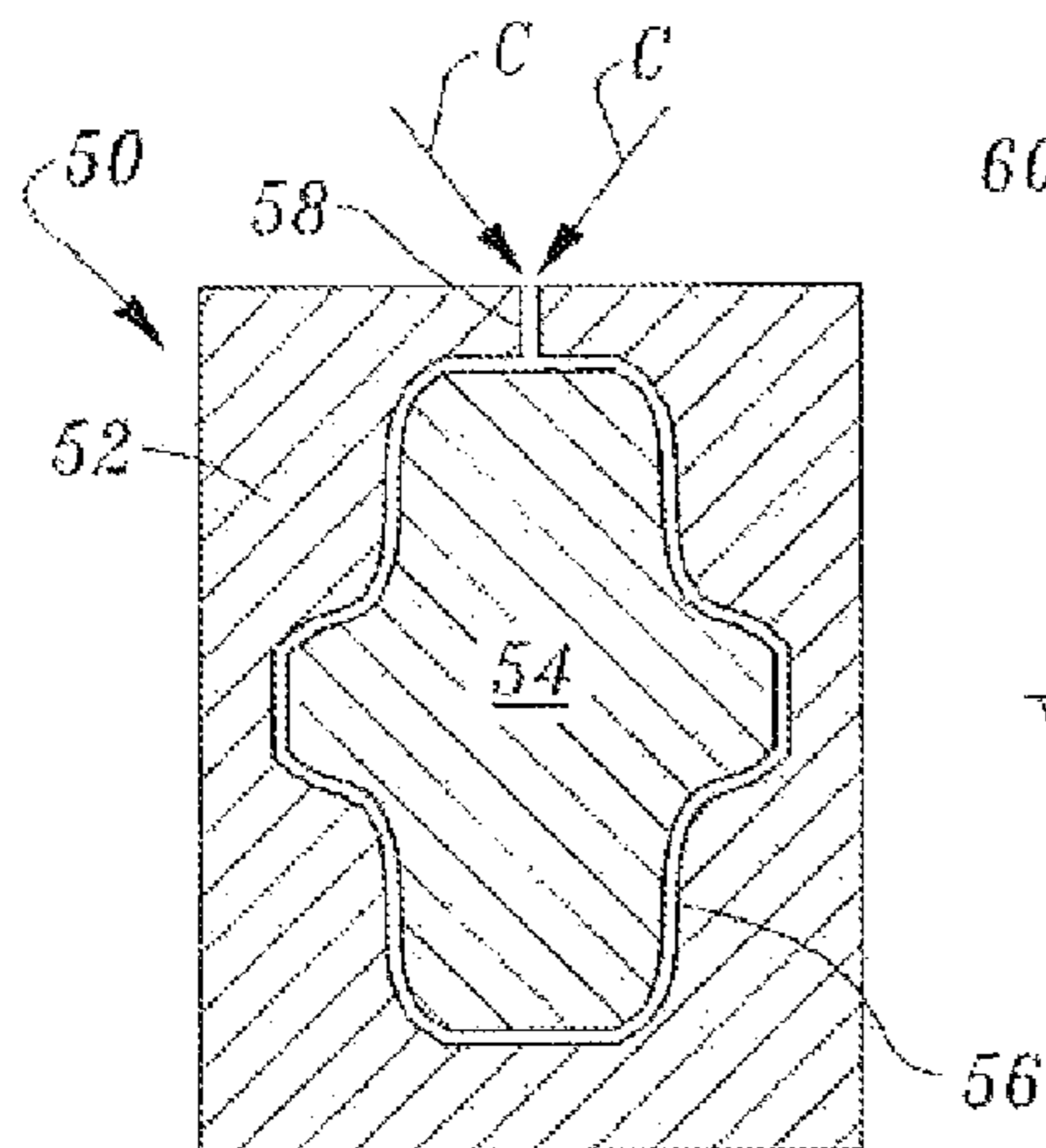

Fig. 7

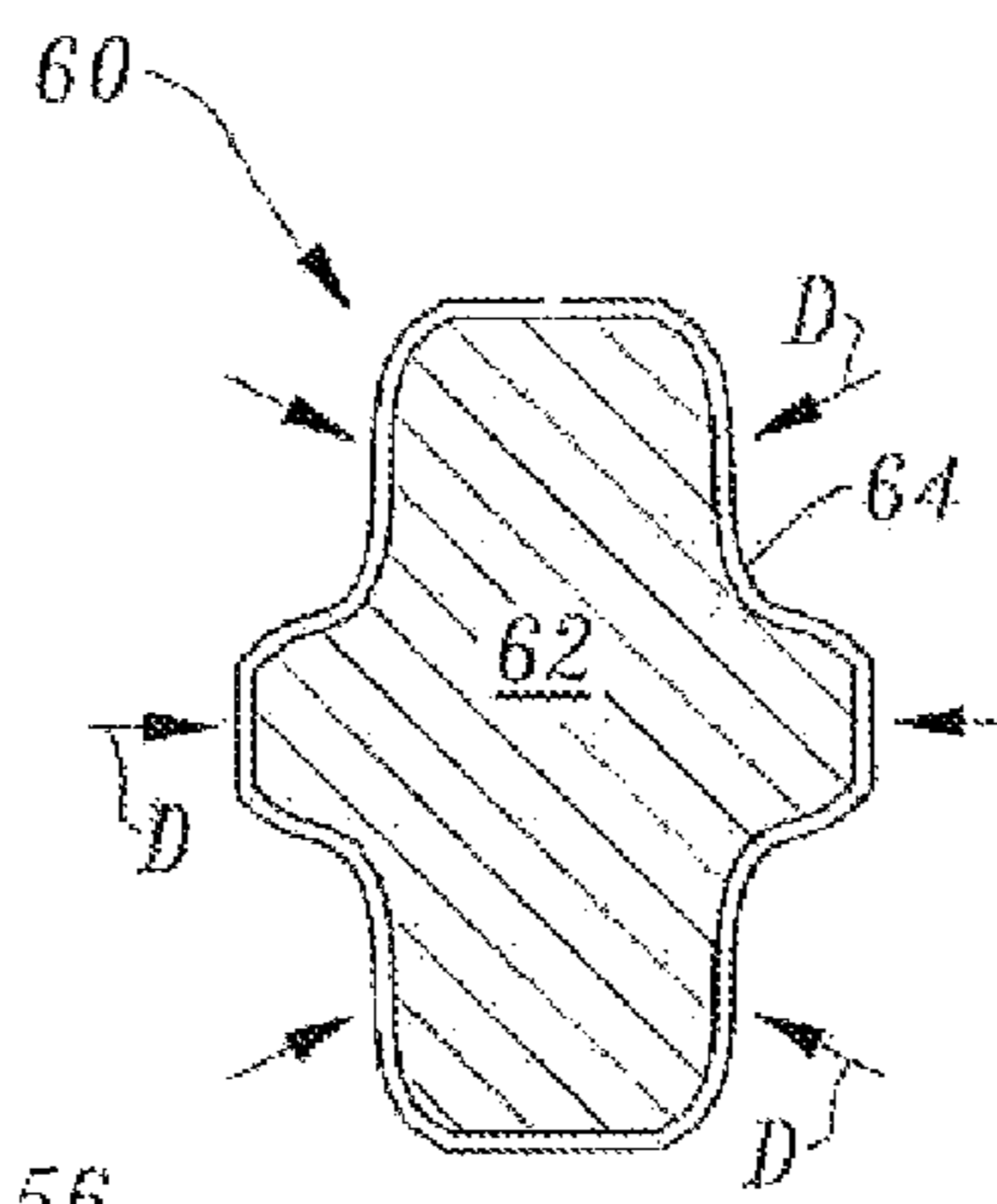

Fig. 8

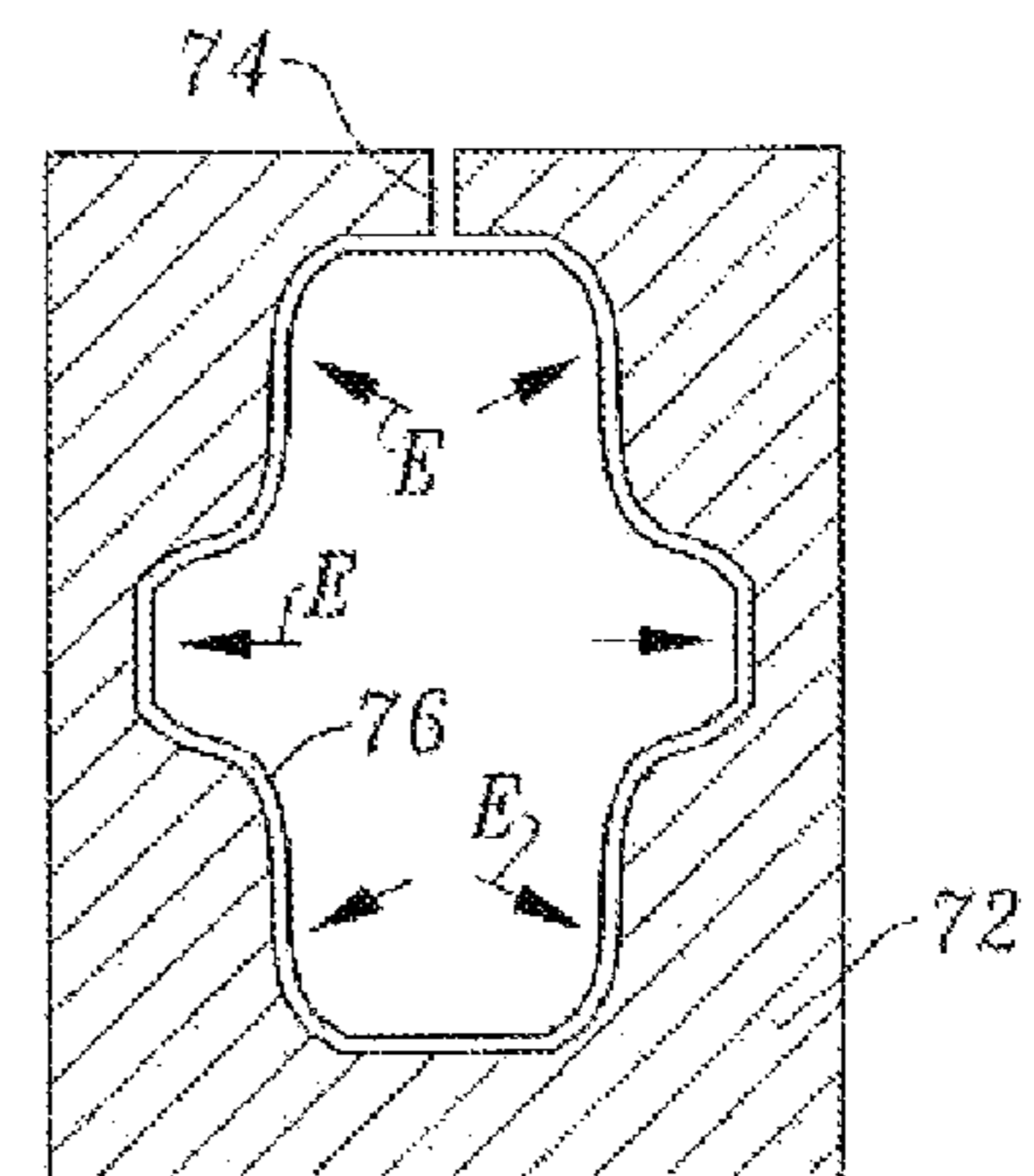

Fig. 9

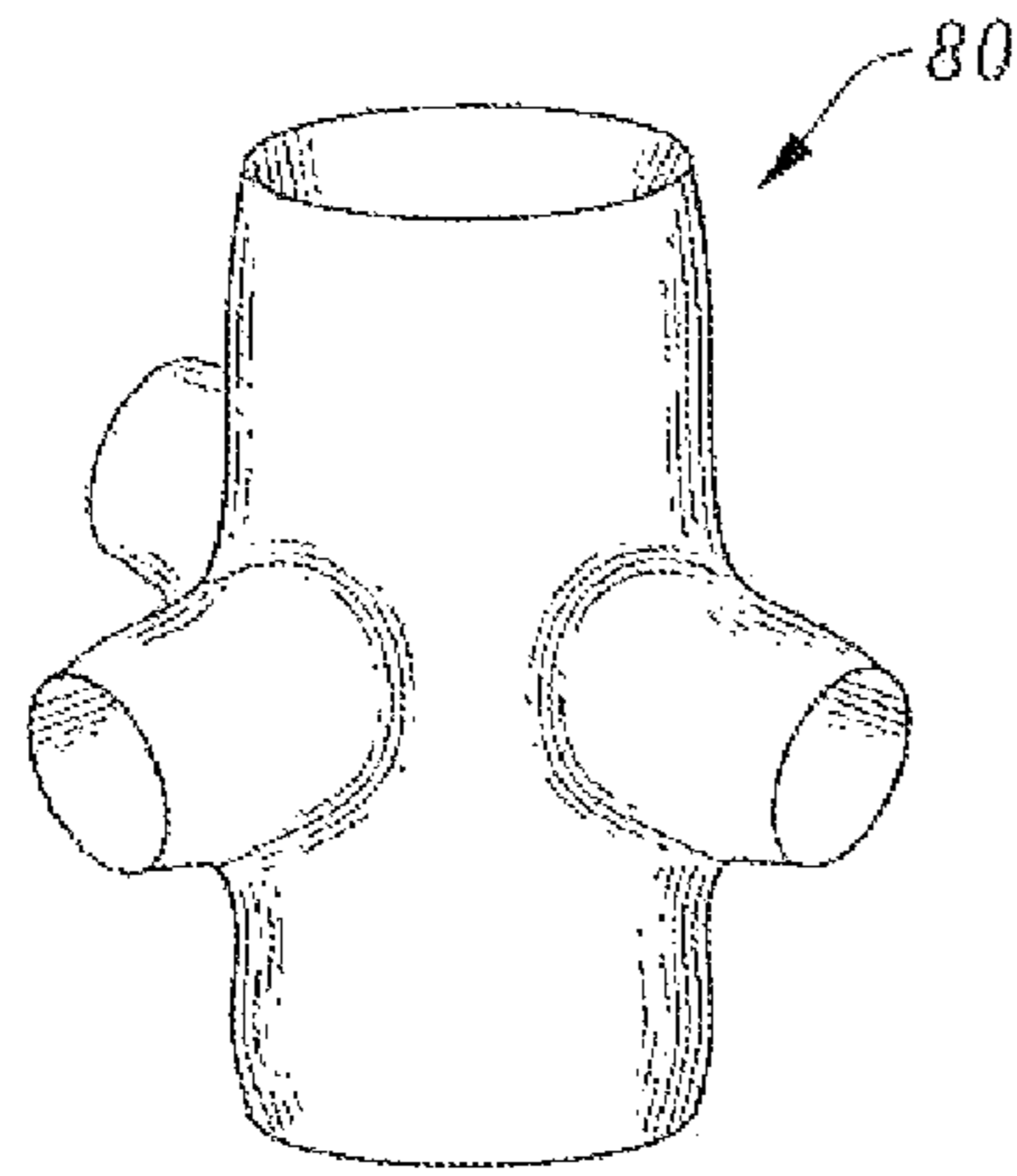

Fig. 10

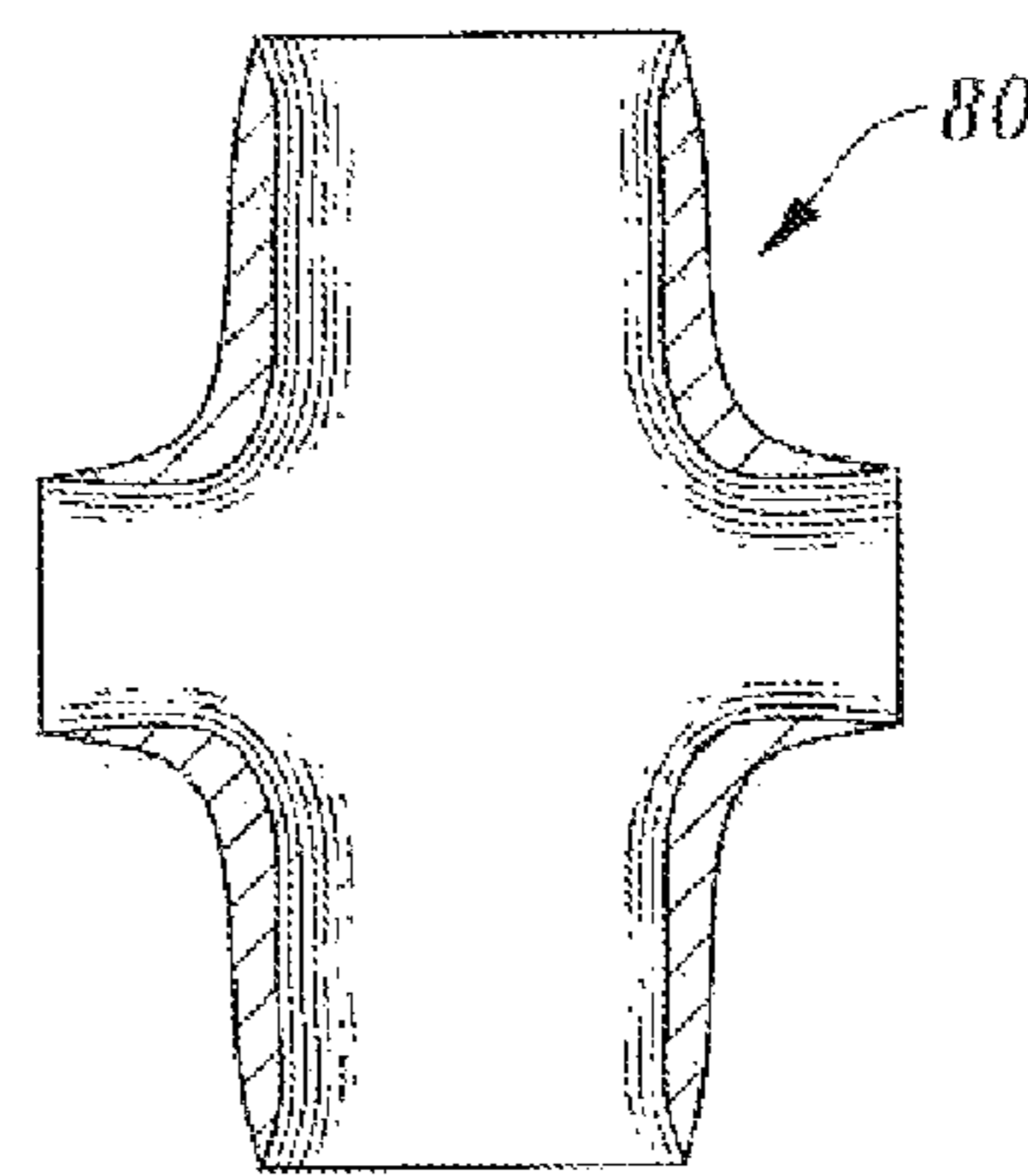

Fig. 11

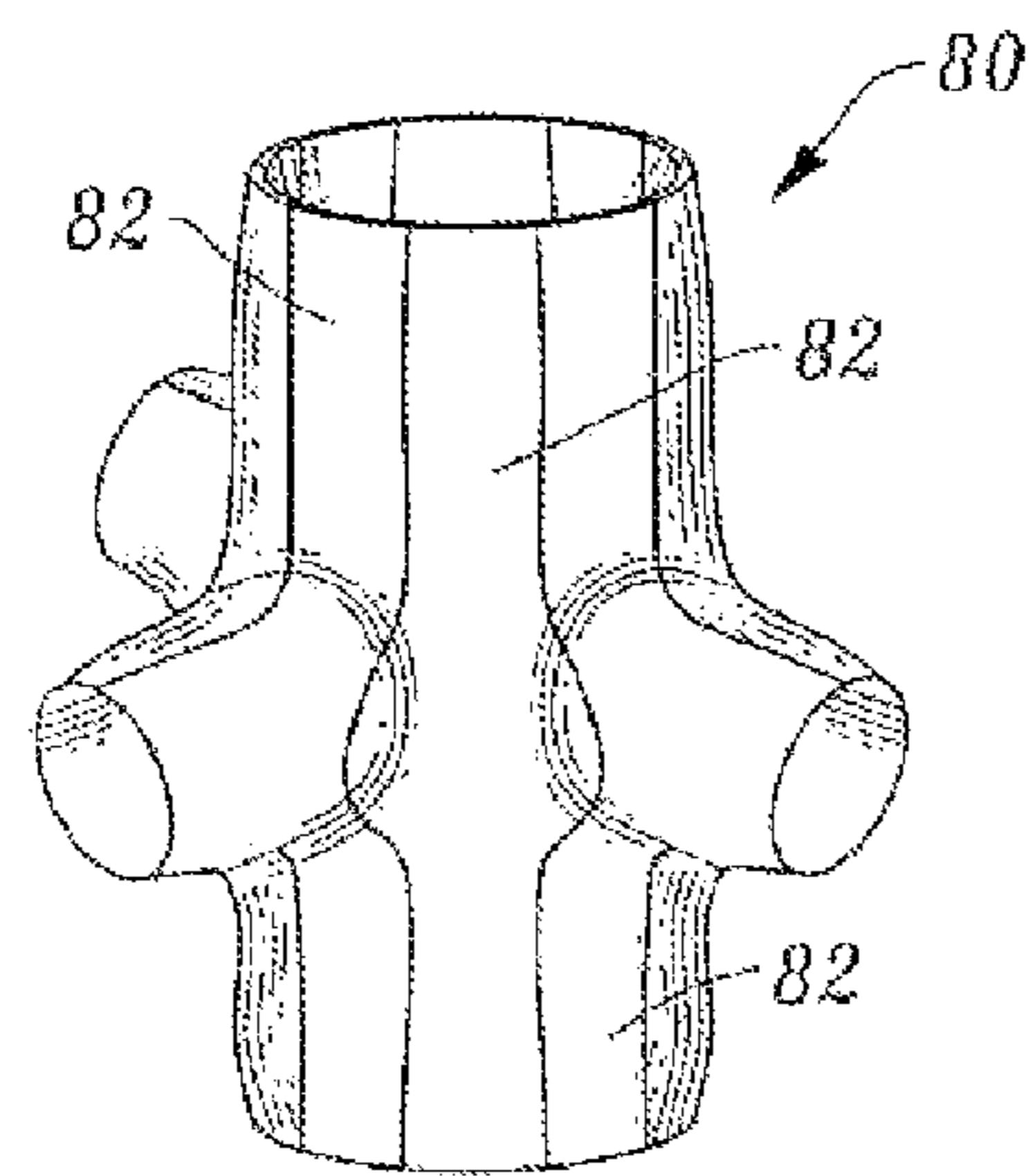

Fig. 12

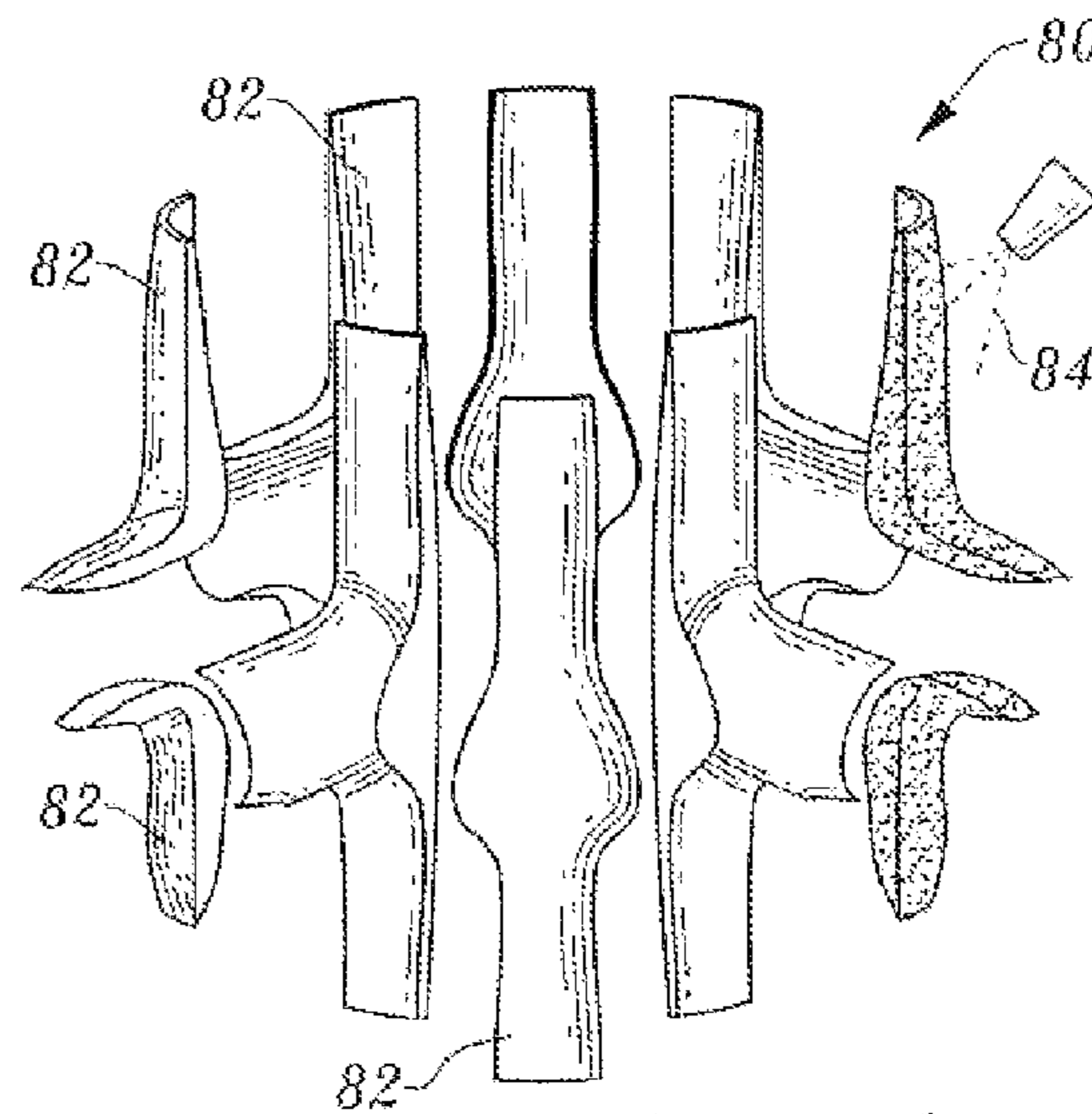

Fig. 13

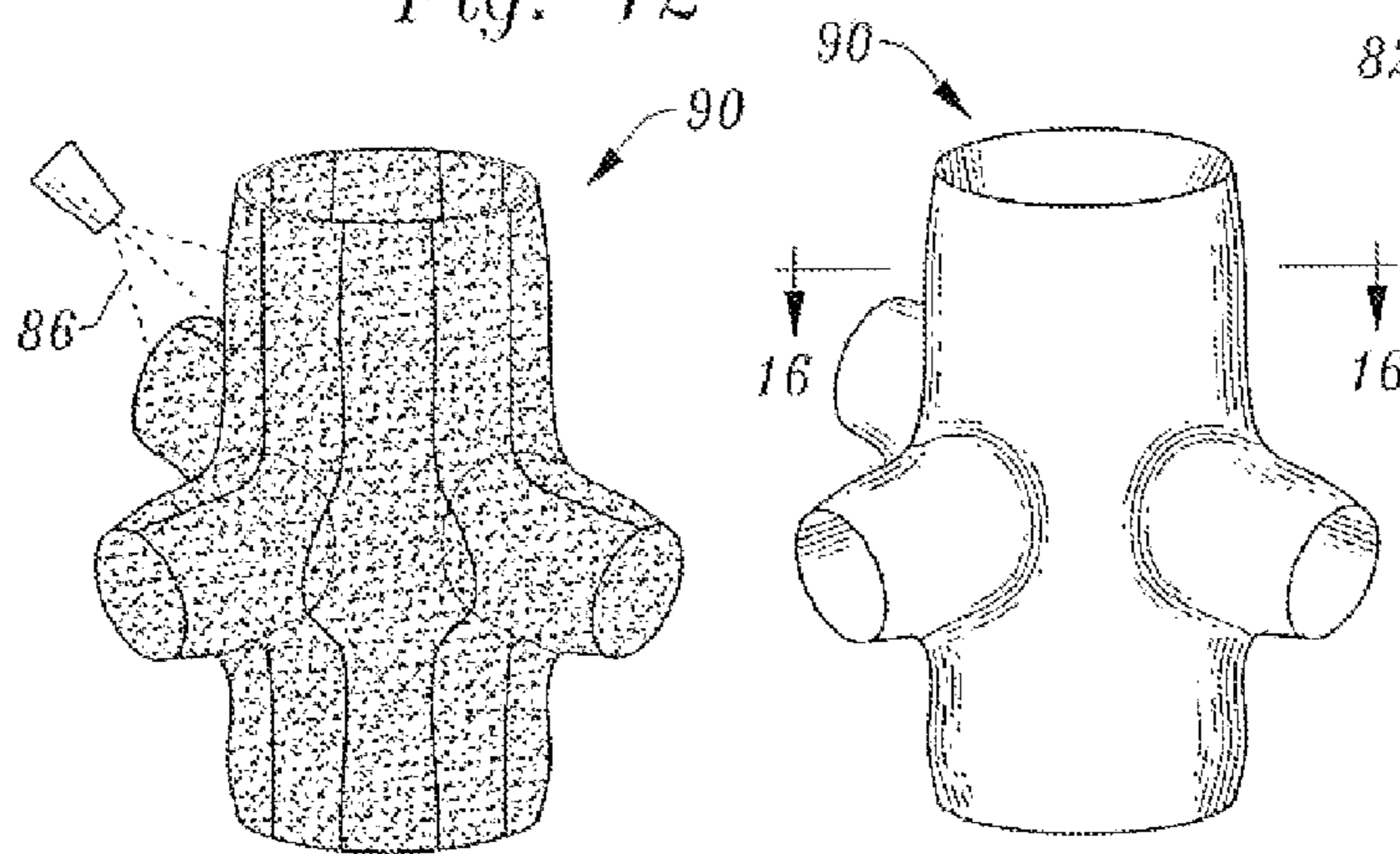

Fig. 14

Fig. 15

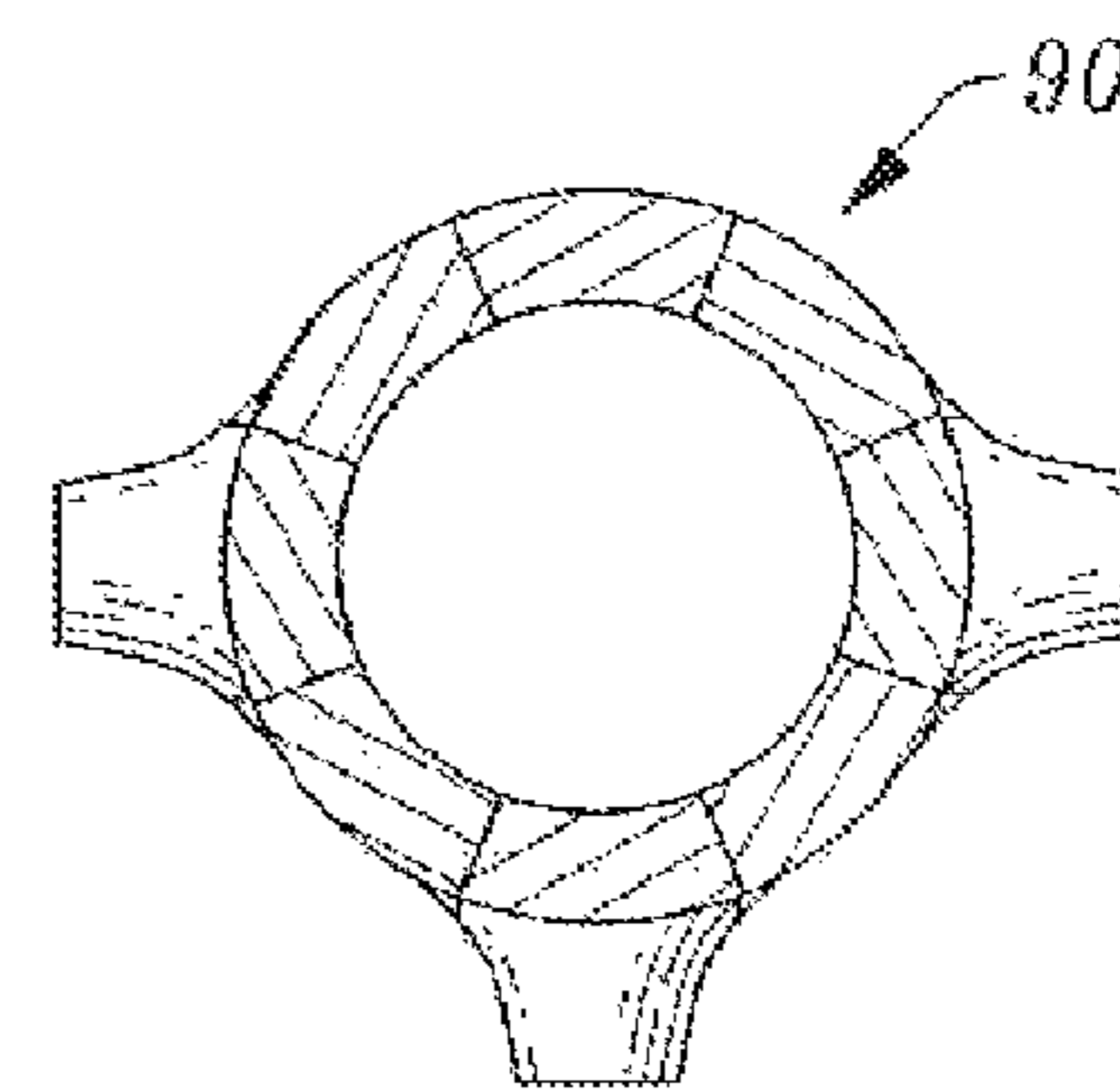

Fig. 16

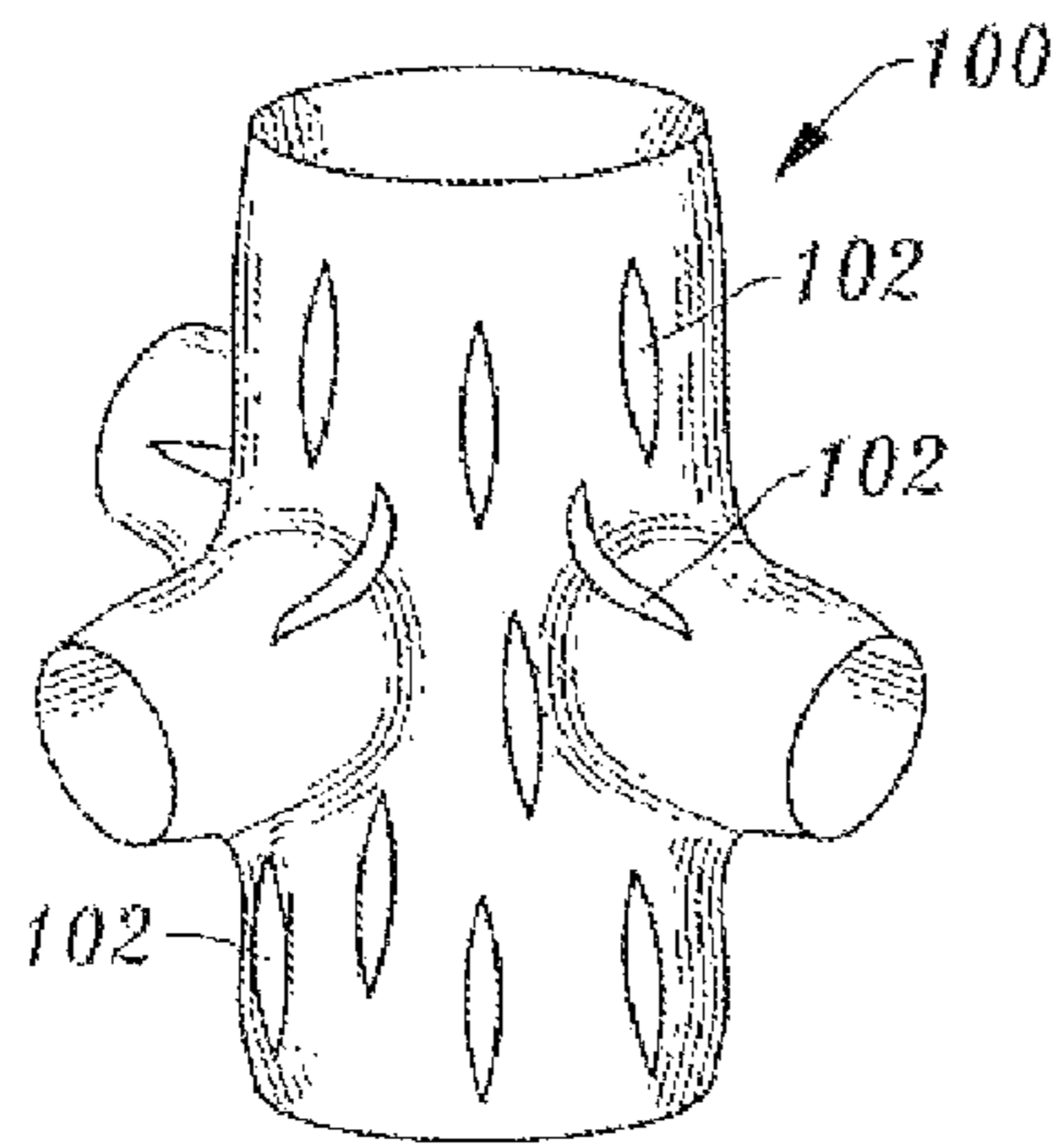

Fig. 17

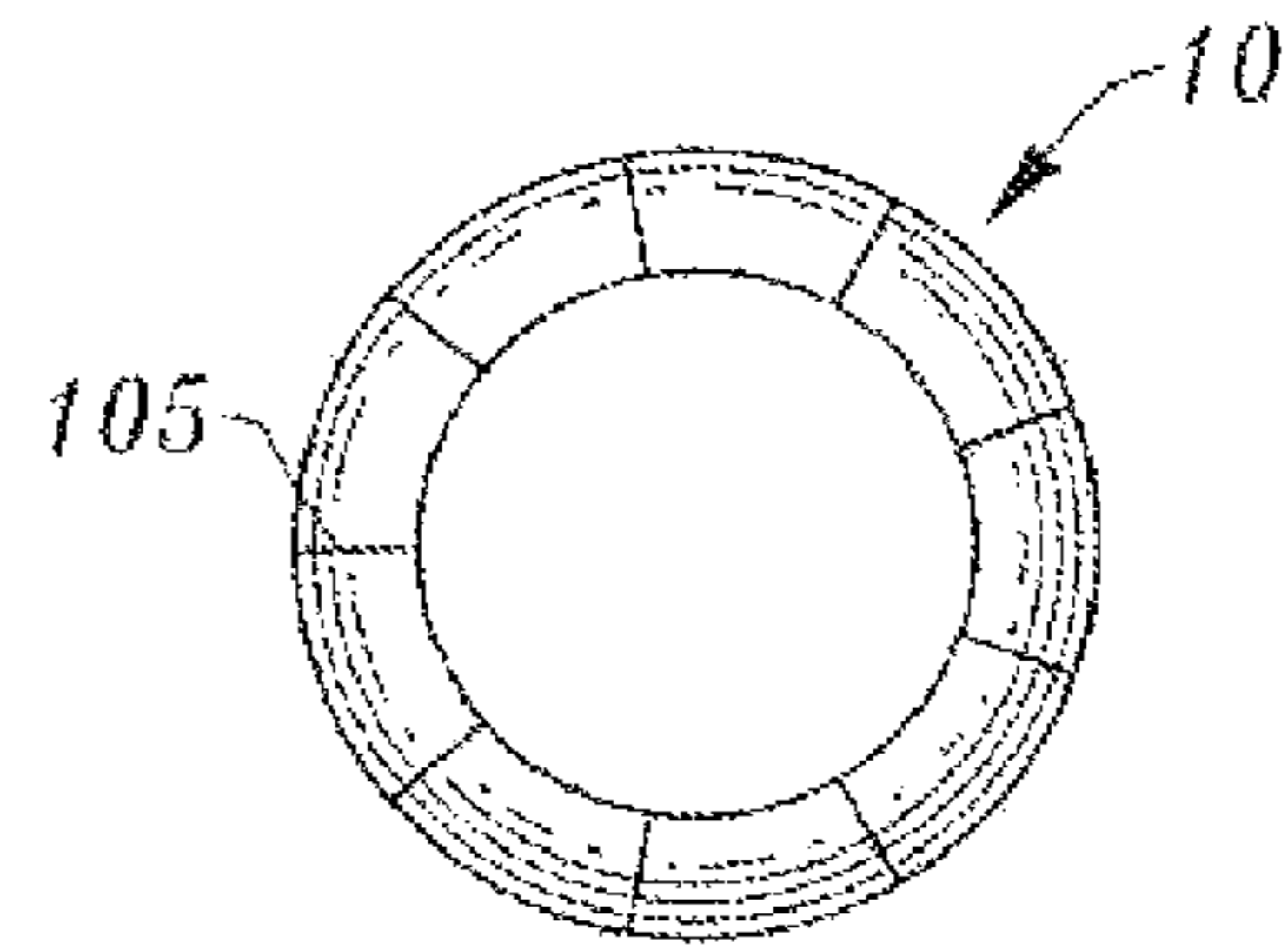

Fig. 18

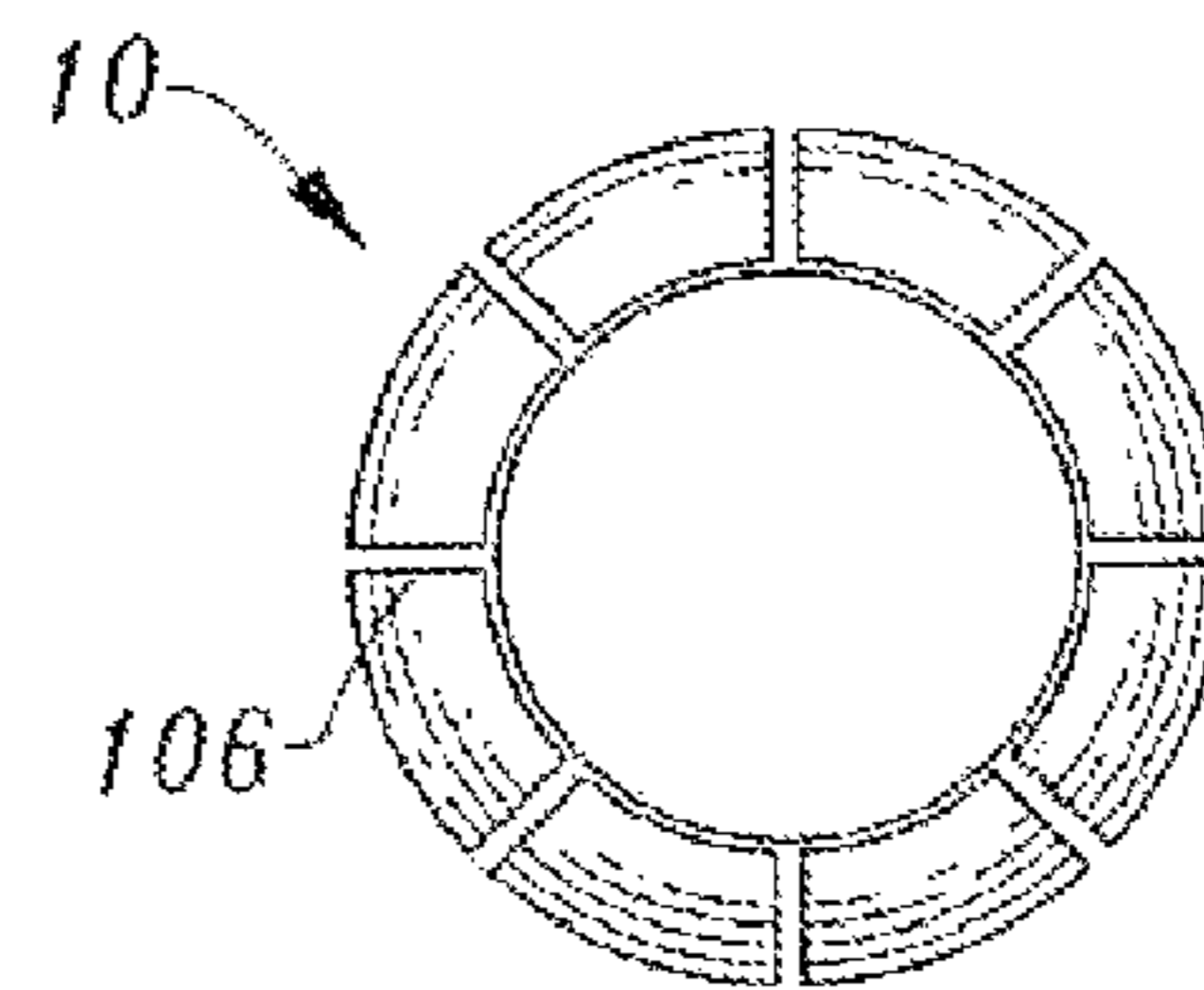

Fig. 19

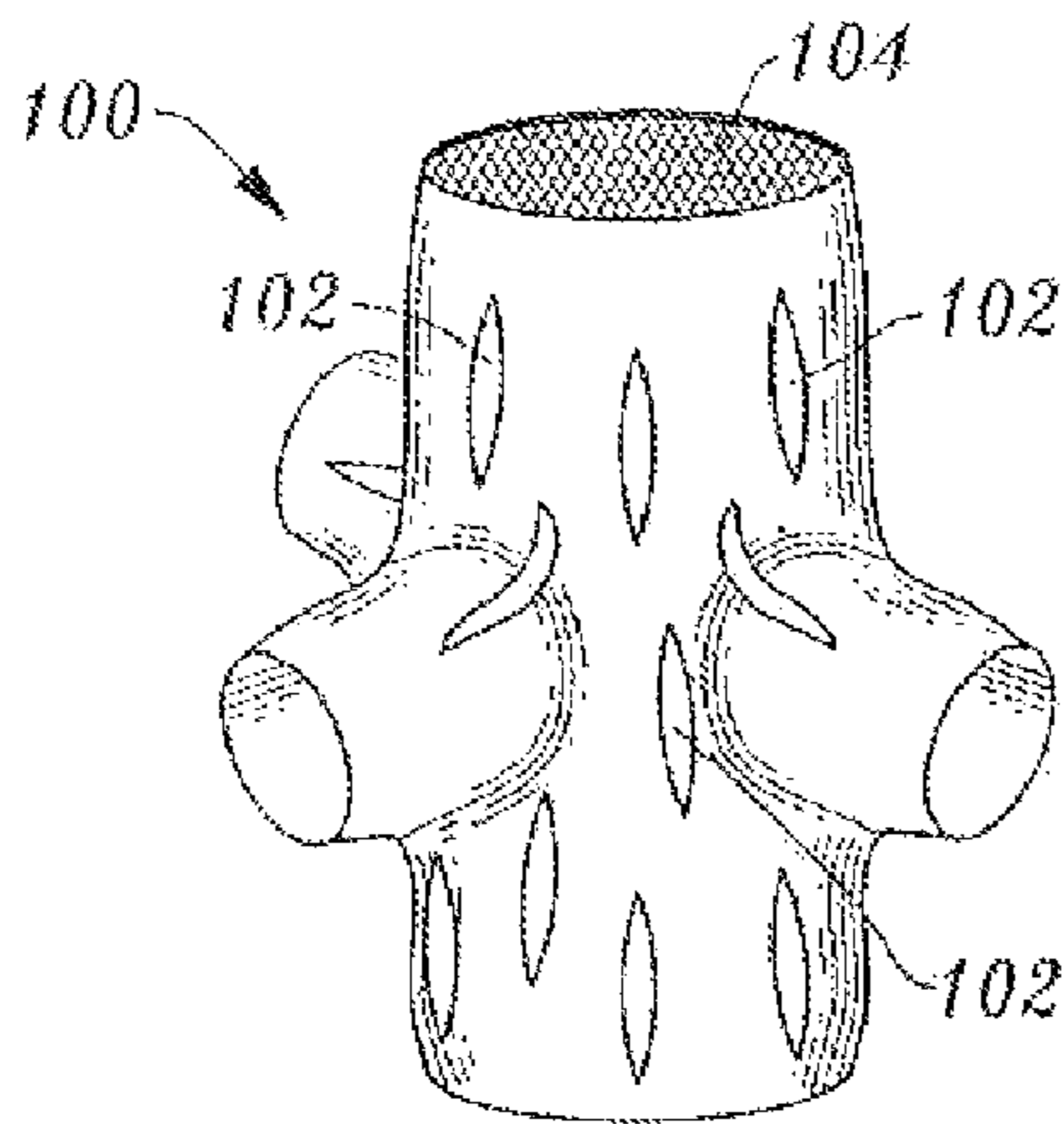

Fig. 21

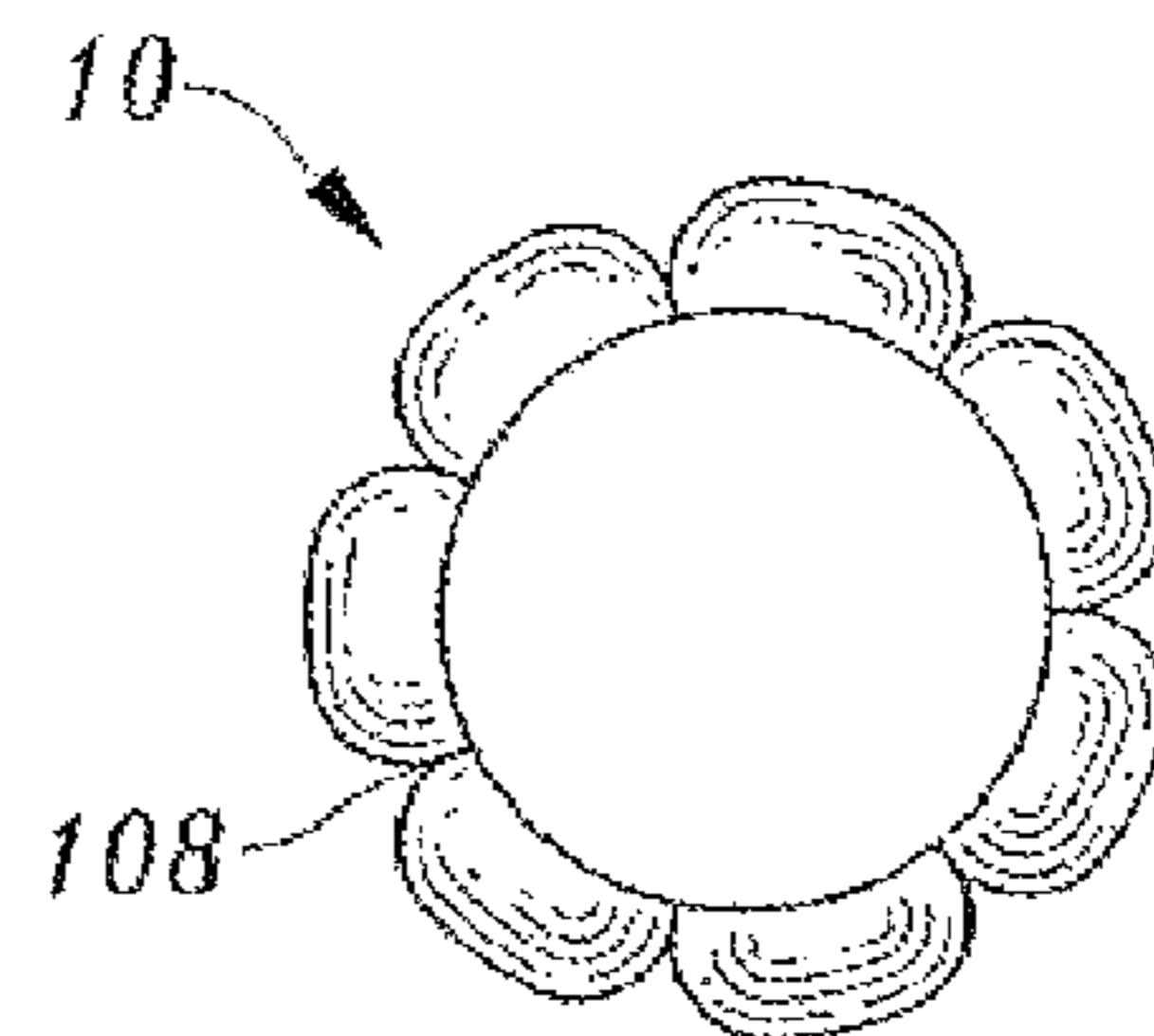

Fig. 20

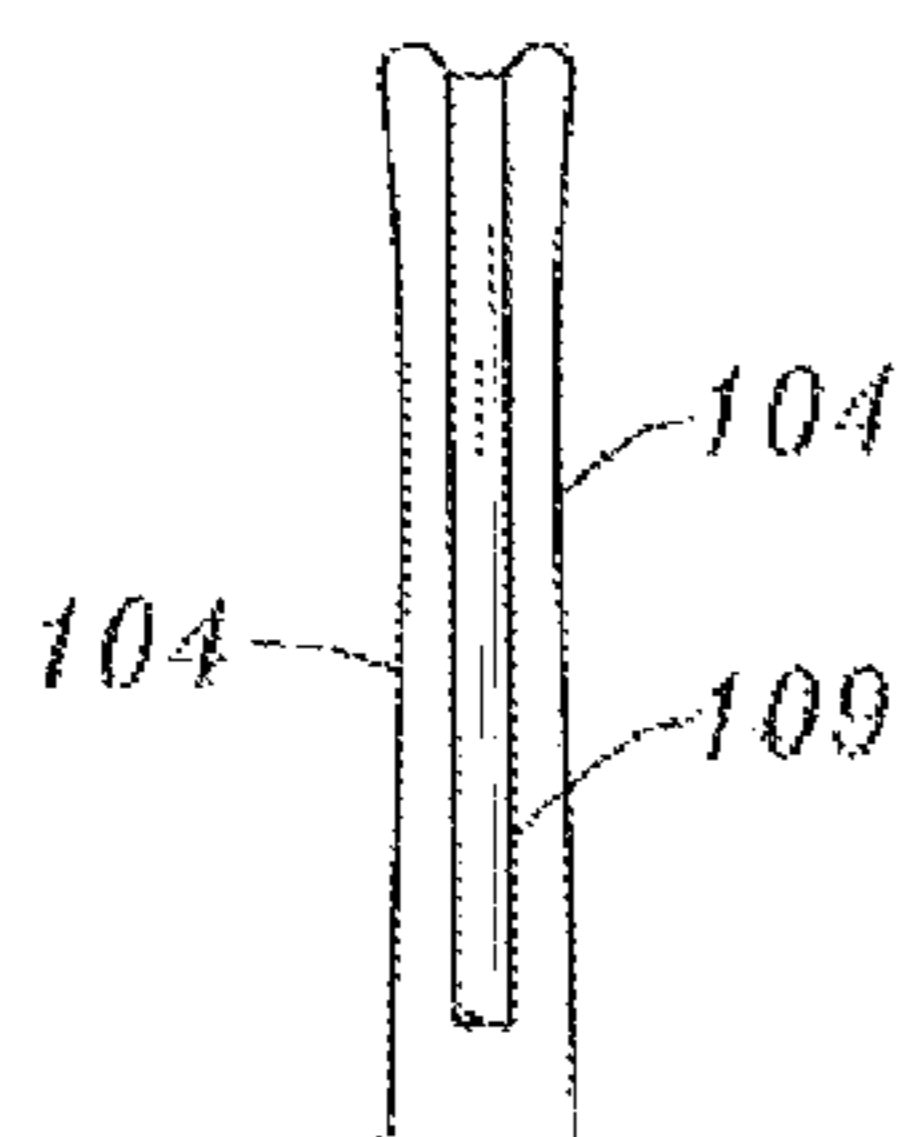

Fig. 22

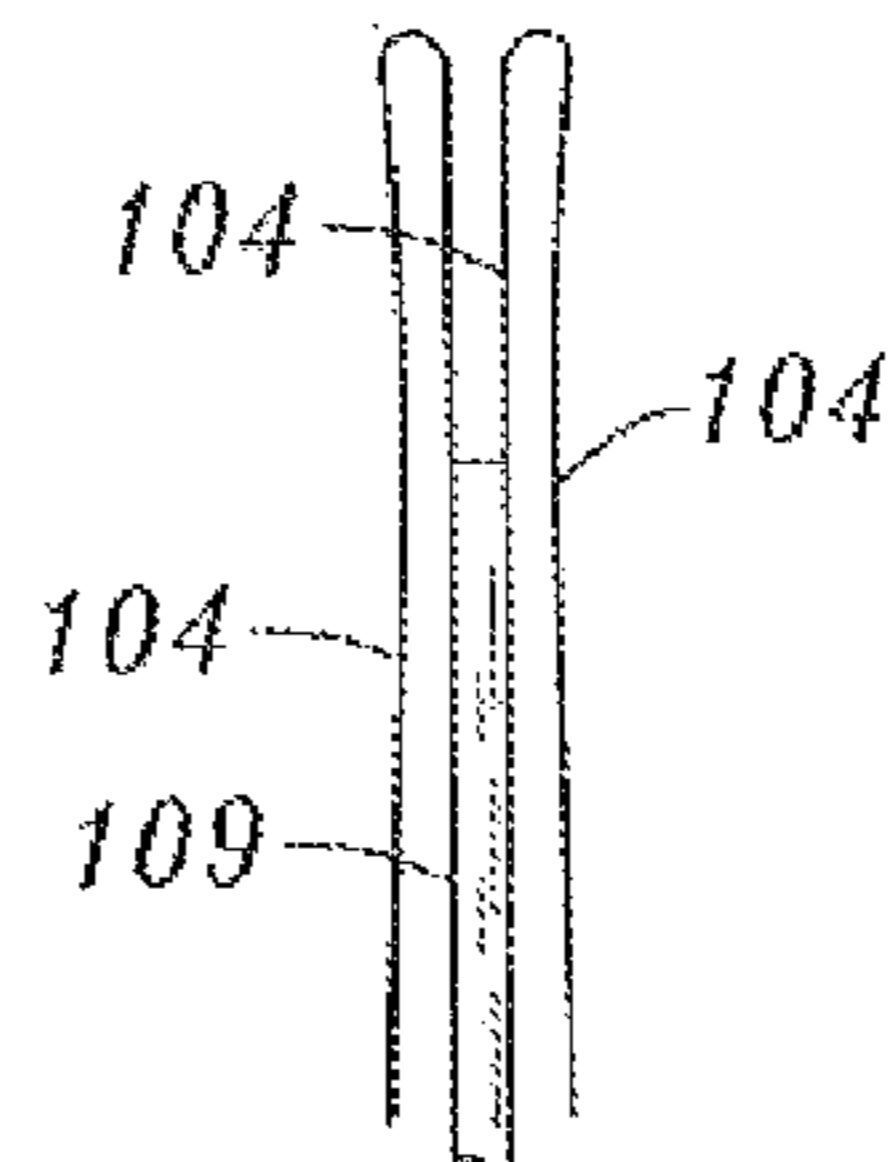

Fig. 23

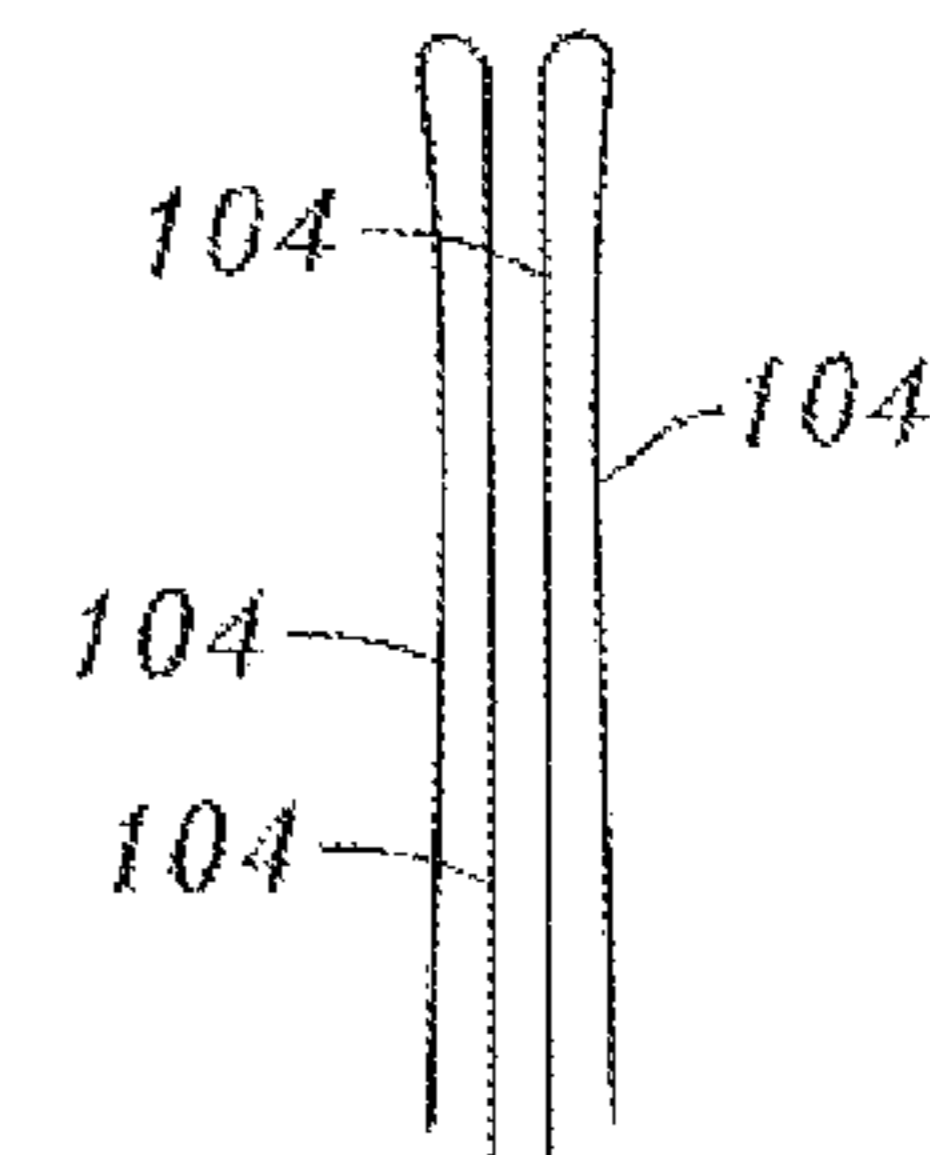

Fig. 24

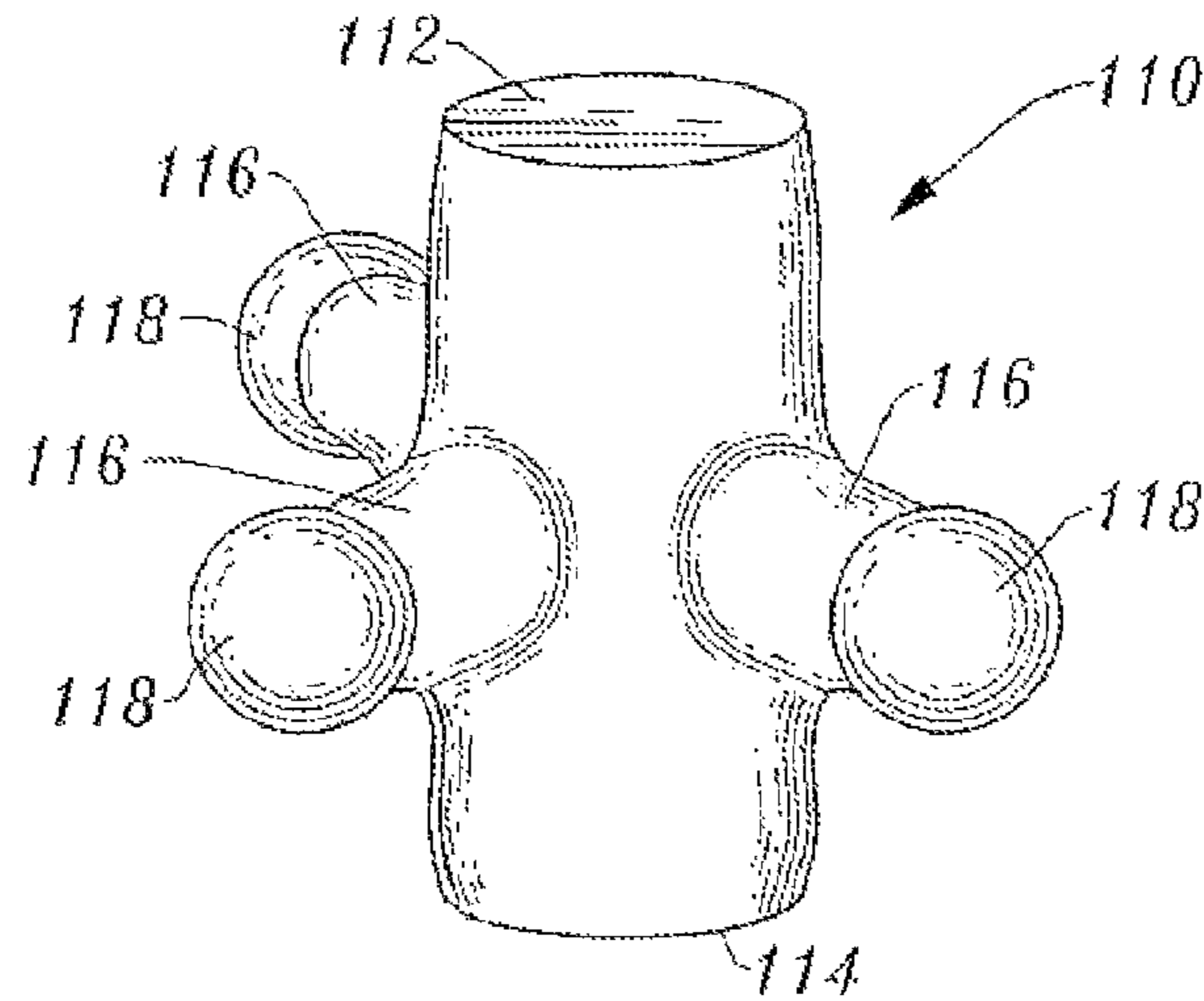

Fig. 25

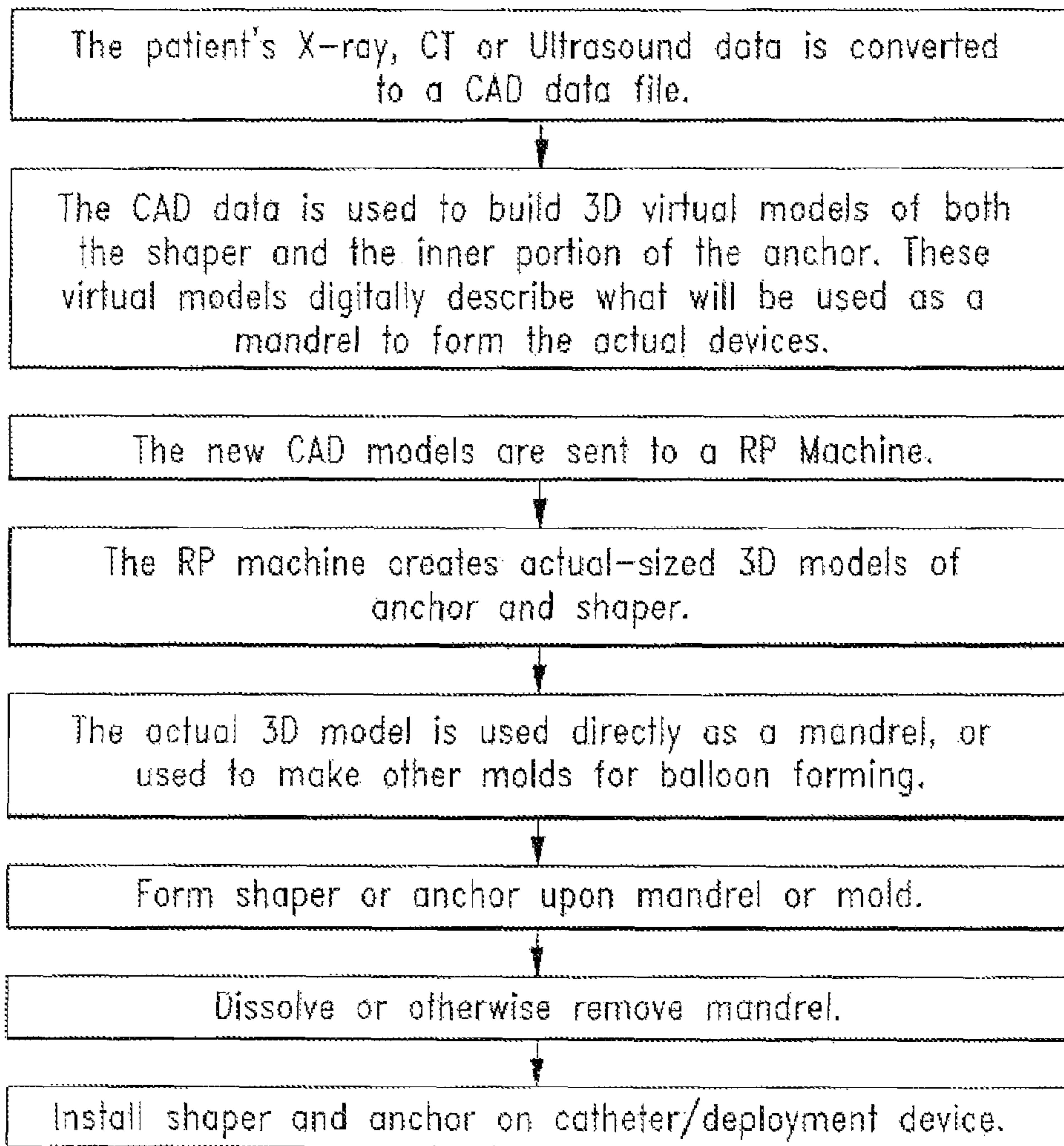

Fig. 26

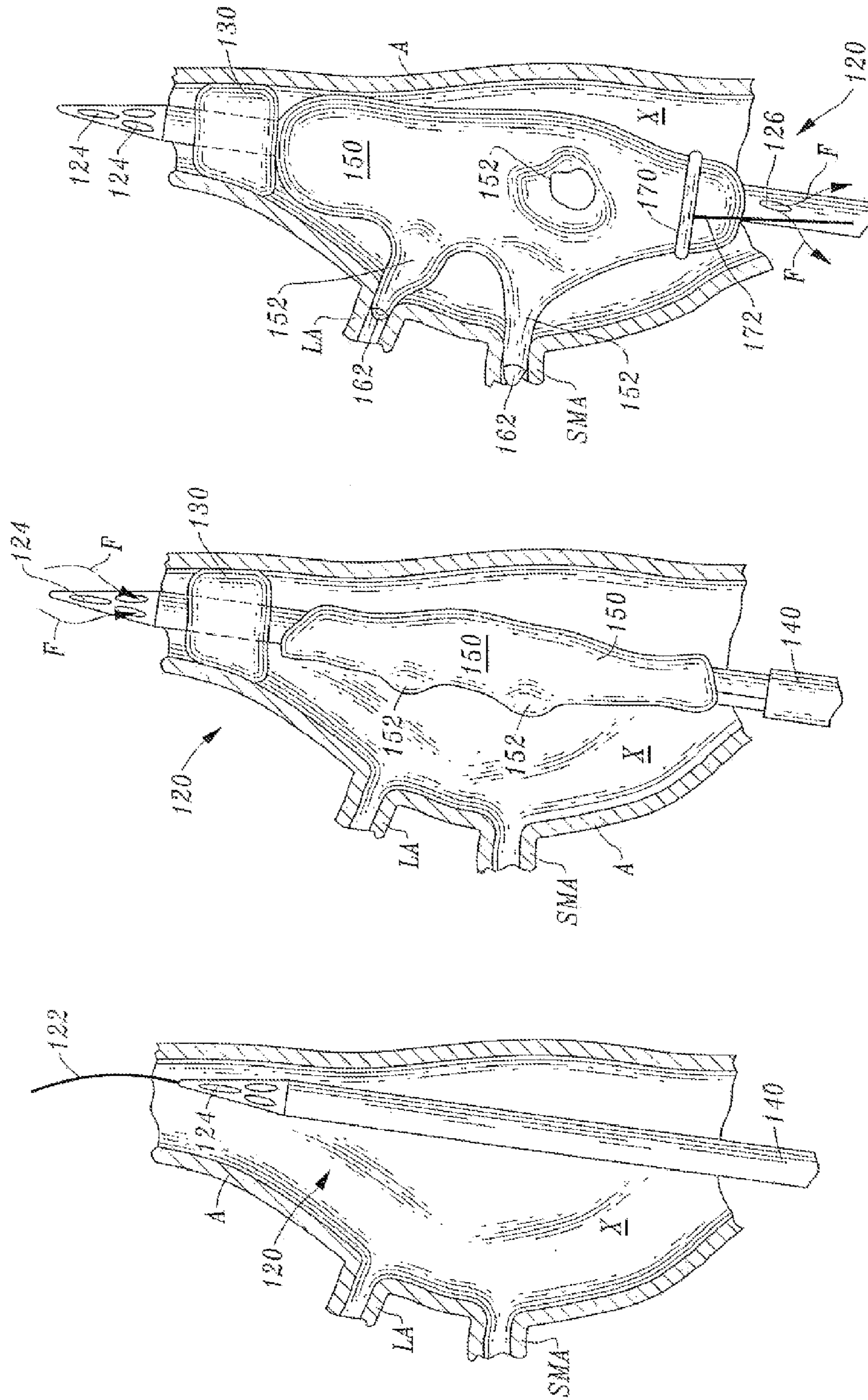

Fig. 29

Fig. 28

Fig. 27

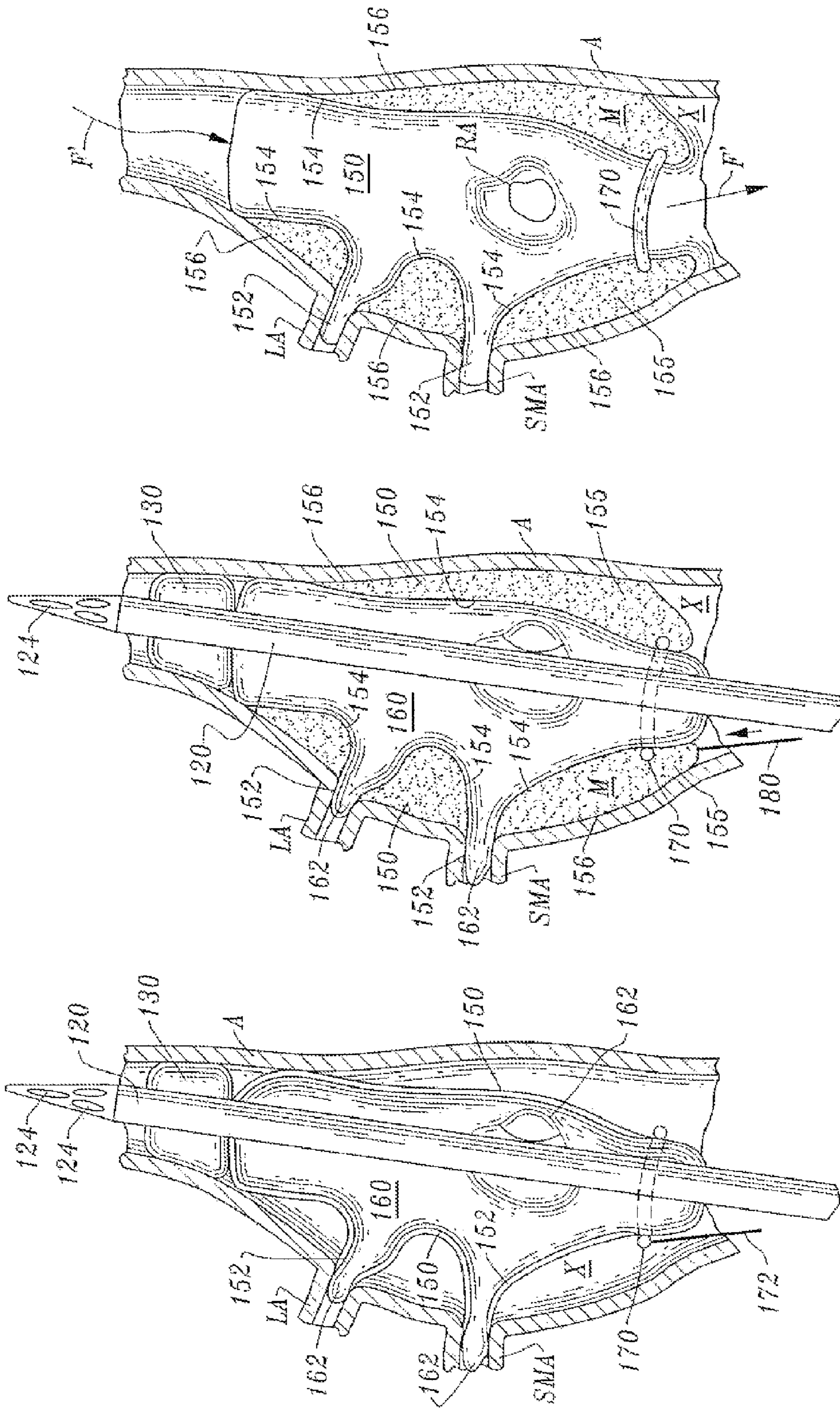

Fig. 32

Fig. 31

Fig. 30

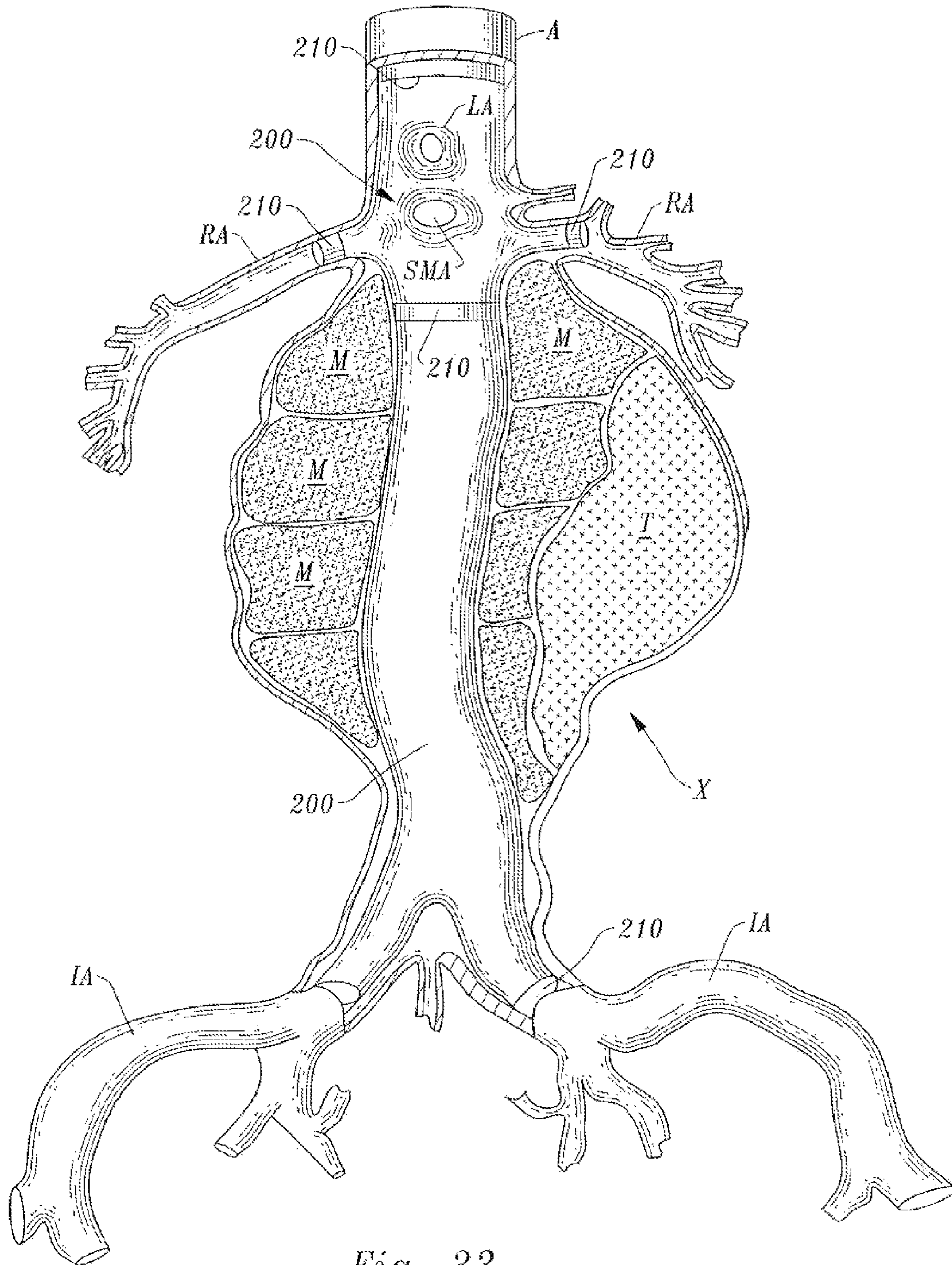

Fig. 33

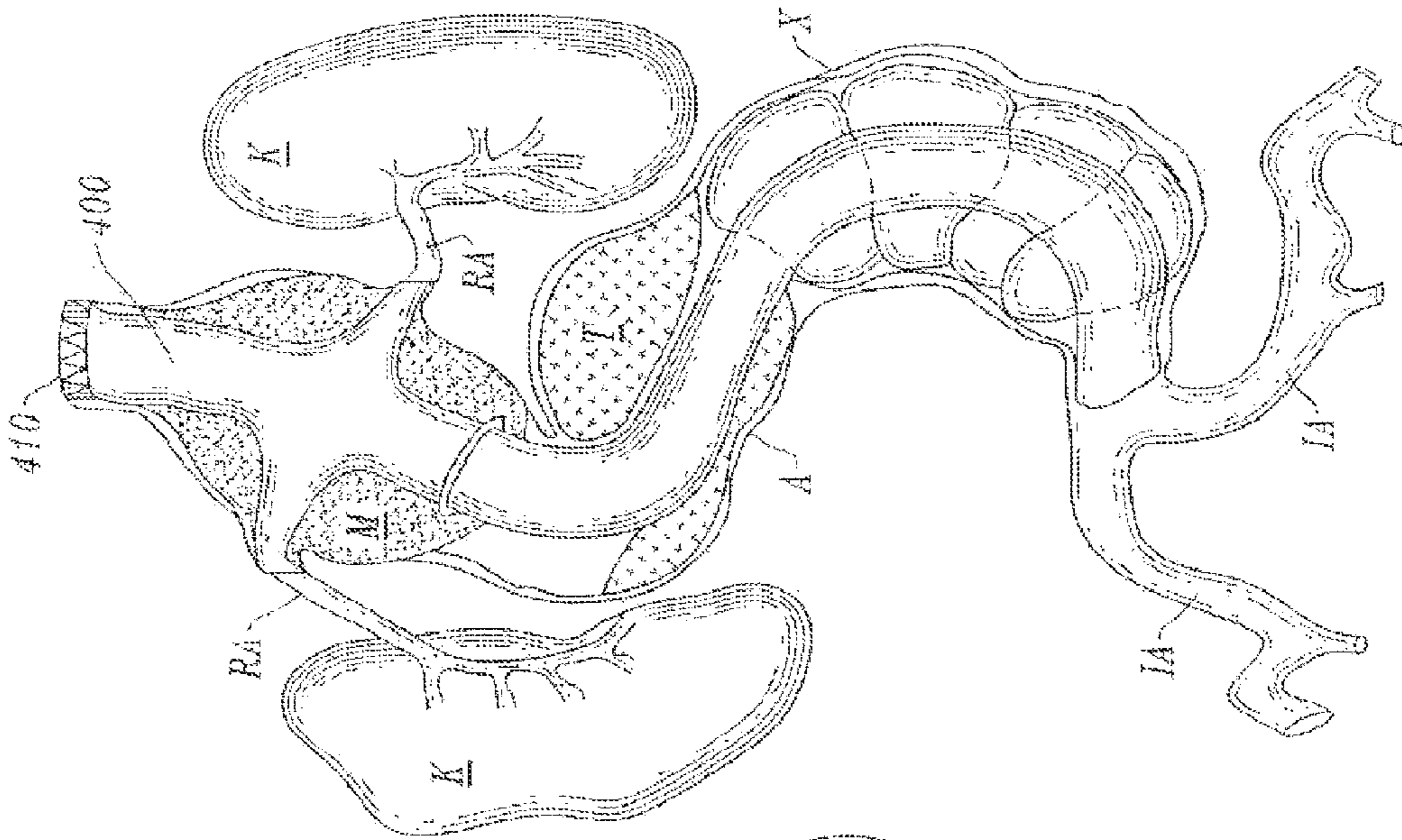

Fig. 36

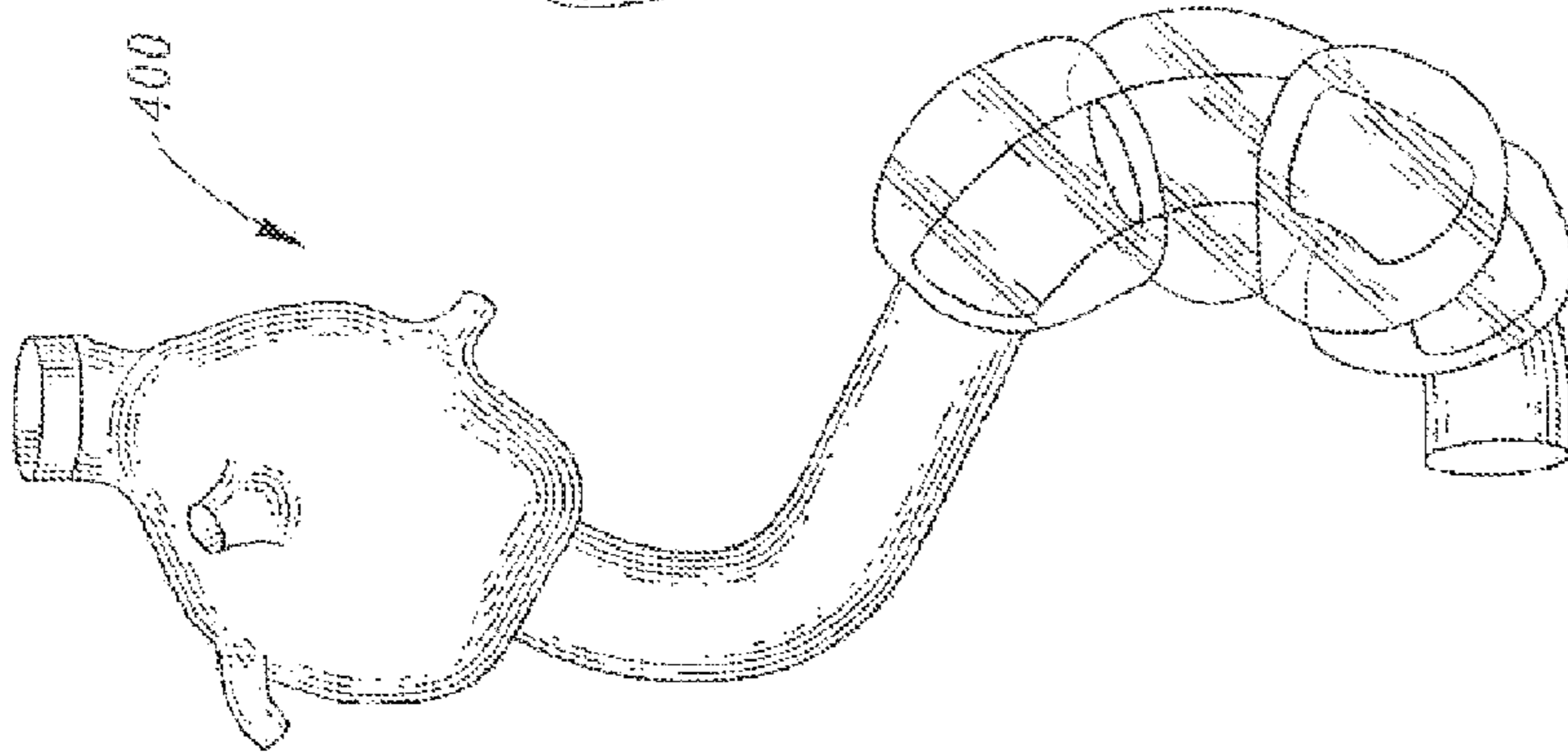

Fig. 35

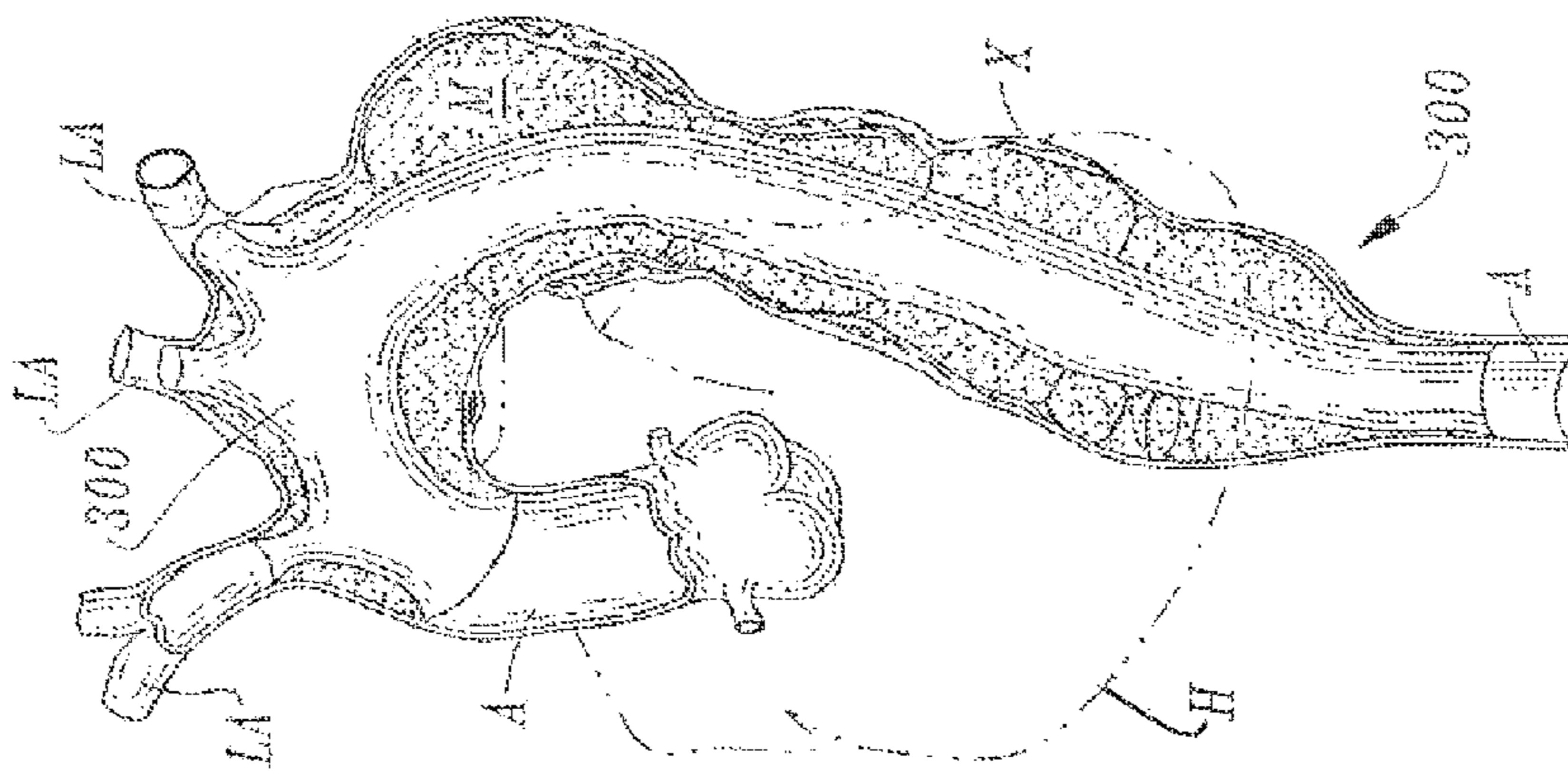

Fig. 34

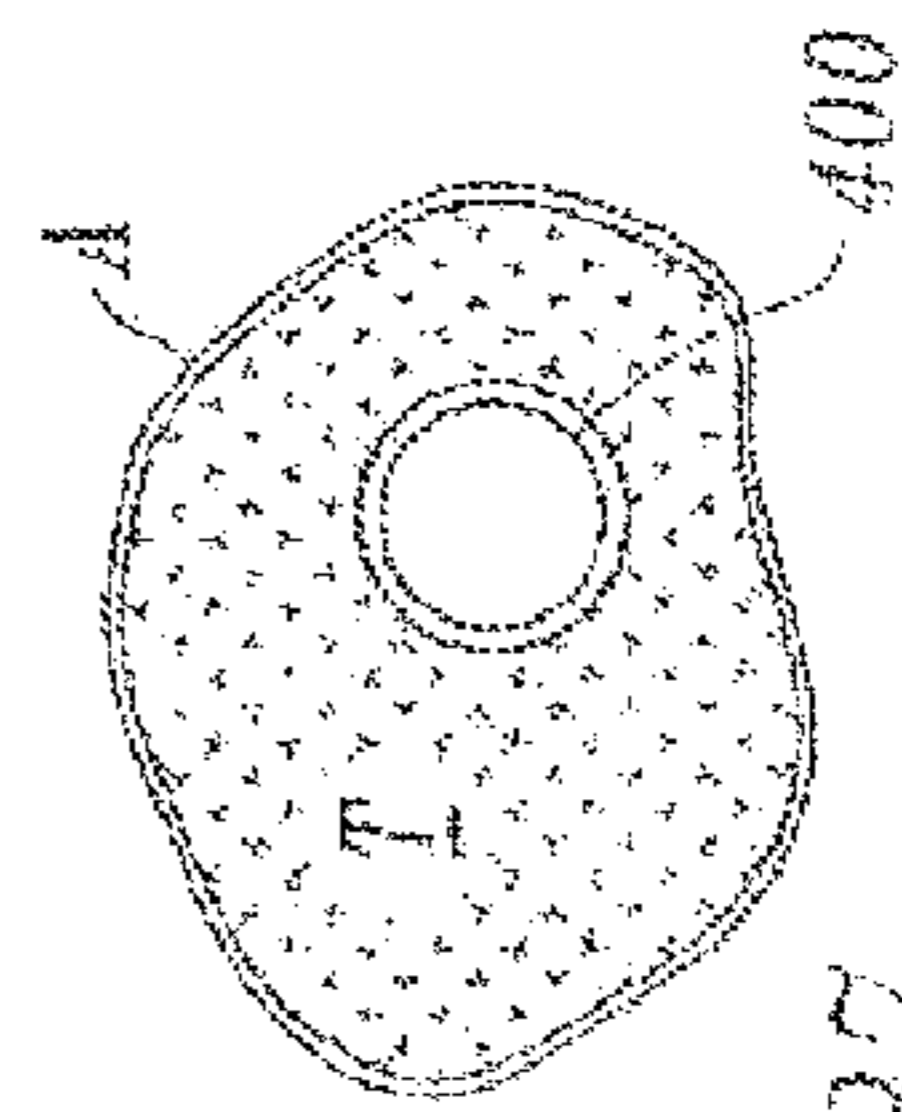

Fig. 37

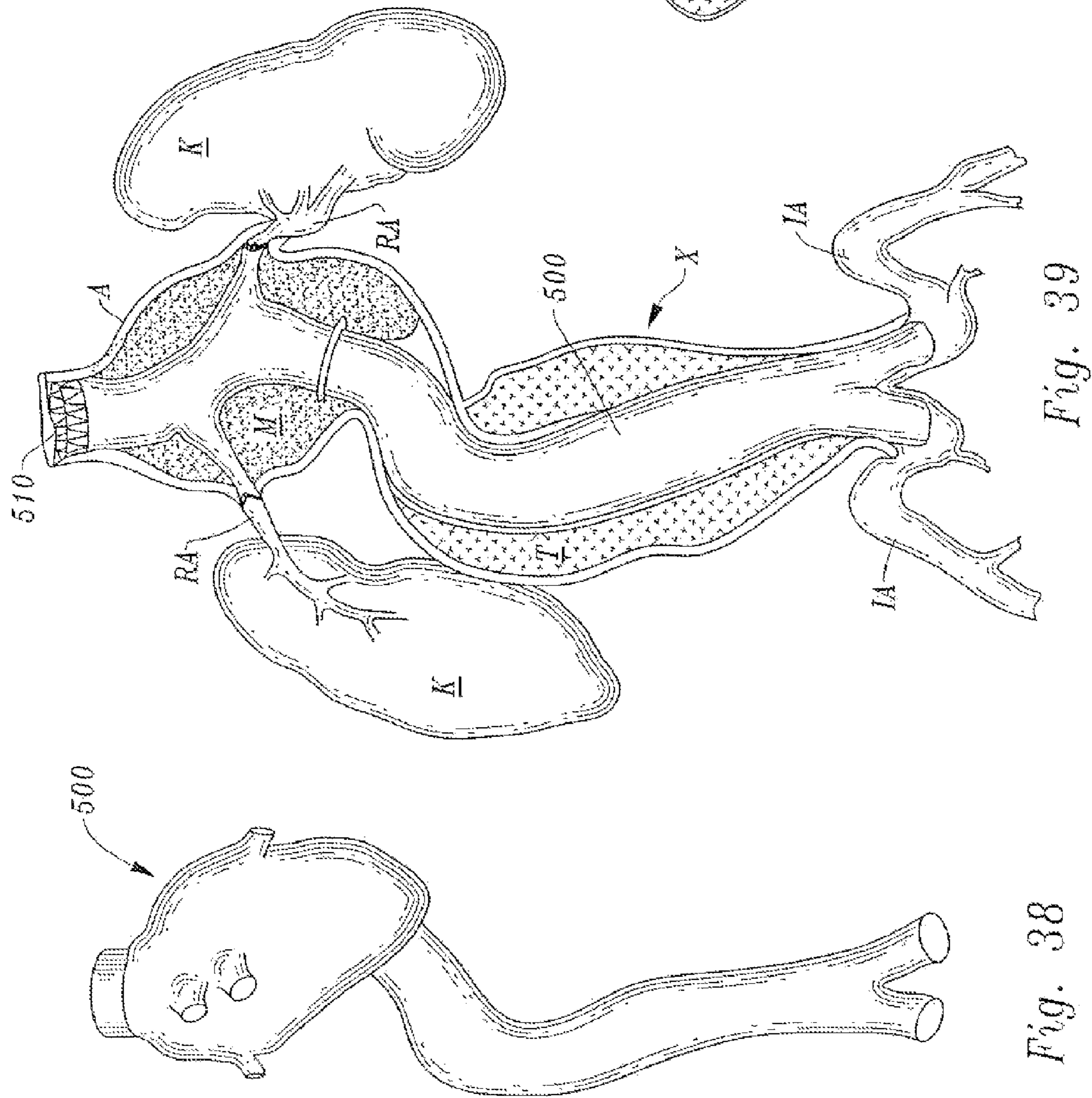

Fig. 38

Fig. 39

Fig. 40

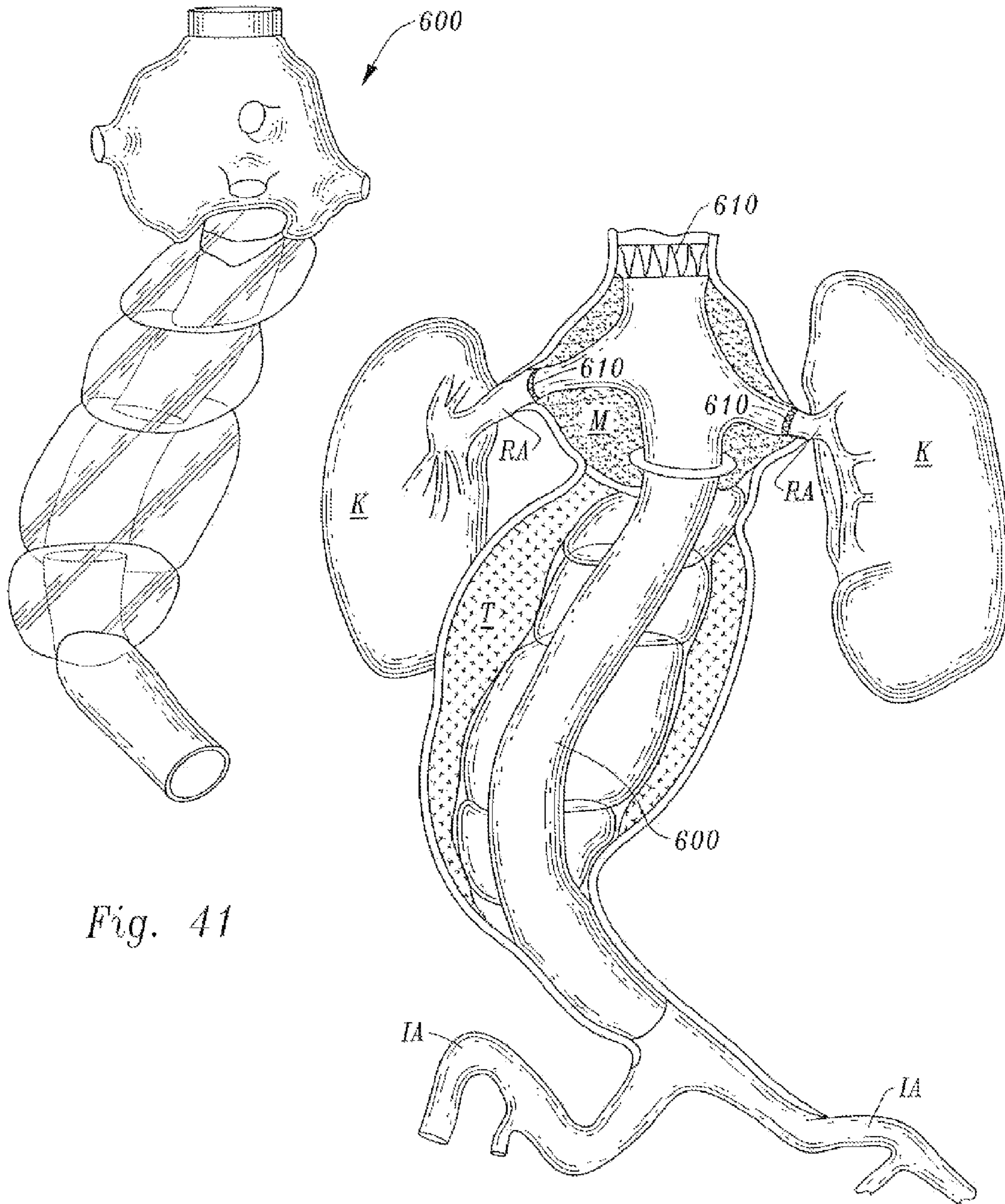

Fig. 41

Fig. 42

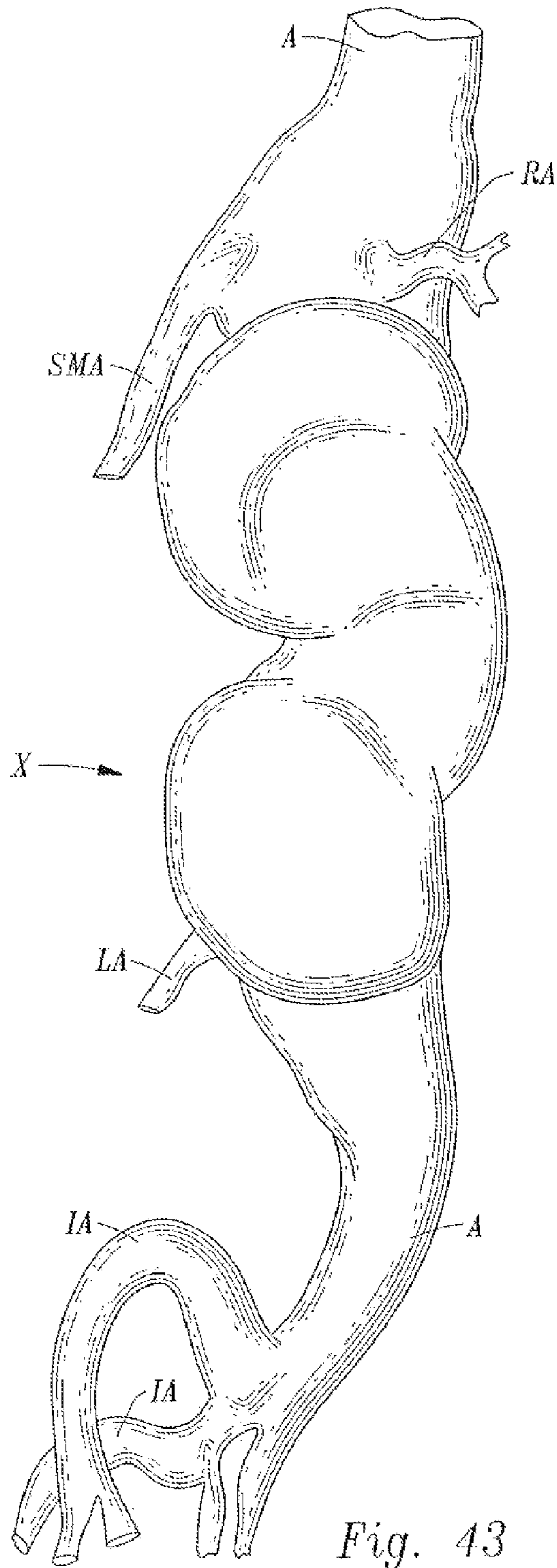

Fig. 43

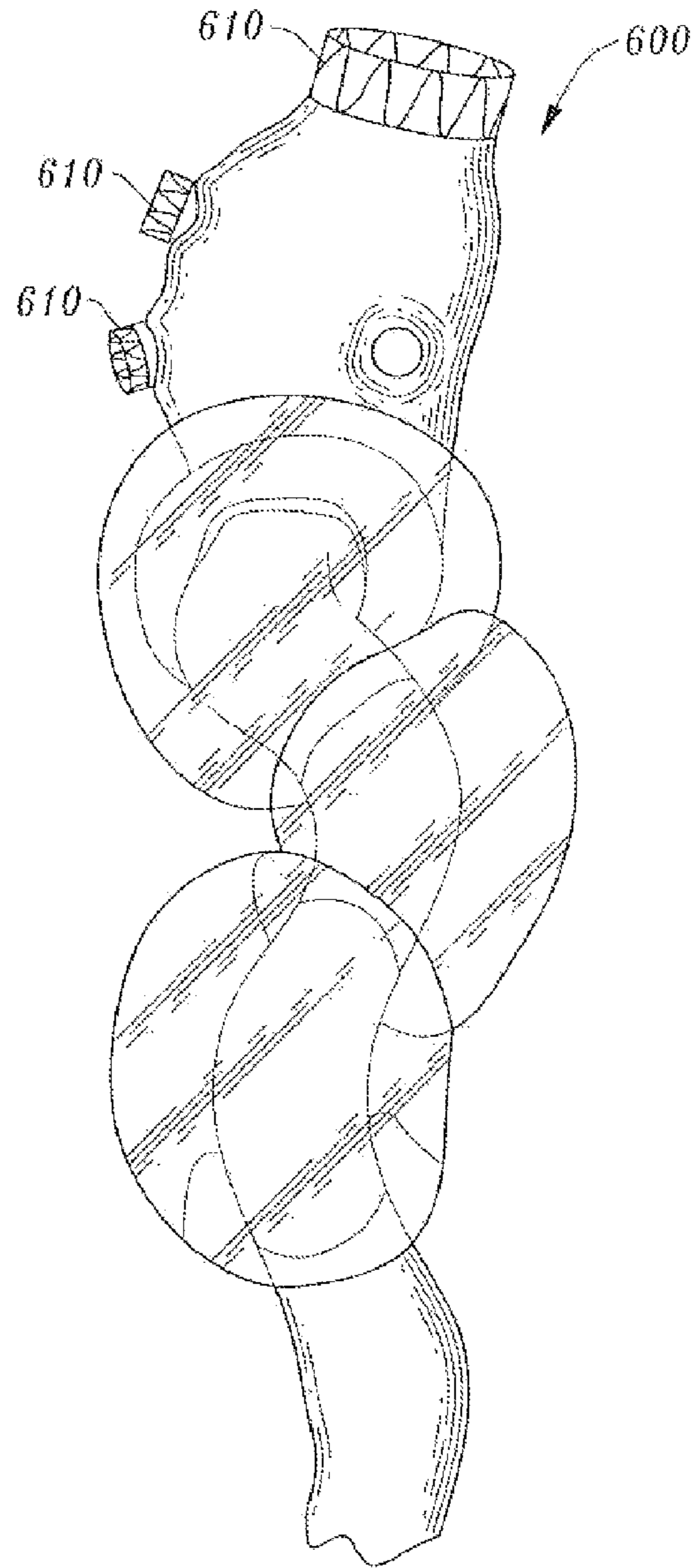

Fig. 44

1

METHODS FOR DEPLOYING A POSITIONING ANCHOR WITH A STENT-GRAFT

CROSS-REFERENCES TO RELATED APPLICATIONS

The present application is a divisional of U.S. patent application Ser. No. 10/668,901, filed on Sep. 22, 2003, now abandoned which claimed the benefit of provisional U.S. Application No. 60/412,501 filed on Sep. 20, 2002, the full disclosures of which are incorporated herein by reference.

BACKGROUND OF THE INVENTION

1. Field of the Invention

The following invention relates to stent-grafts for implantation into body lumens for support of the body lumens and to provide for repair and proper fluid flow through the body lumen. More particularly, this invention relates to stent-grafts which include anchors to keep the stent-grafts in a desired position, especially when implanted intraluminally, and most particularly to stent-grafts for intra-luminal implantation into the aortic artery of a human patient.

Stents are known in the surgical arts which are implanted intraluminally or otherwise and expanded to support the lumen and maintain fluid flow through the lumen. Such stents are often used in arteries where blood flow has become restricted with the stent propping the artery open to maintain proper fluid flow.

When an artery or other lumen becomes damaged, replacement of the damaged artery section with a graft may be indicated. Such grafts can be taken from other body lumens of the patient, or be in the form of an artificial prosthesis. Such grafts can replace a portion of the damaged artery or be implanted intraluminally or otherwise within the damaged section of the artery without removal of the damaged artery itself. The graft then supports blood flow within the damaged artery.

For grafts to function properly, they must be held in place where desired within the artery or other lumen. One technique for maintaining the proper position of the graft is to utilize a stent within a portion of the graft with the stent radially expanded to hold the portion of the graft adjacent the stent in position relative to the artery or other body lumen. Such a graft held in place by a stent can be provided as a single assembly for implantation, being then often referred to as a stent-graft. The stent can be coextensive with the graft or only provided at specific locations along the graft. The stent both acts to hold the graft in the desired position and also to maintain the desired open cross-section of the artery to maintain proper blood flow. When a graft is configured to both provide a substitute channel for flow of fluid through a body lumen and to keep the body lumen propped open, it can be referred to as a stent-graft also, even if it does not include a separate stent-like structure which is providing this support function.

One body lumen which is particularly suited to treatment of damage therein with a stent-graft is the aorta when it has developed an aneurysm. Such an aortic aneurysm can occur anywhere between the heart and the iliac arteries, resulting in an undesirable widening of at least a portion of the artery. Once such an aneurysm has formed, it is susceptible to rupture with a high probability of resulting mortality. It is known in the art to install a stent-graft in the aorta where the aneurysm exists. The stent-graft provides a new channel for blood flow through the region of the aneurysm, taking stress off of

2

the arterial wall where the aneurysm exists so that the aneurysm will not rupture, and also channeling blood flow through the stent-graft so that even if the aneurysm were to rupture, internal bleeding would not result. The portion of the aorta which has the aneurysm therein can either be removed or remain in place if the stent-graft is delivered intraluminally or otherwise, within the portion of the aorta having the aneurysm.

One challenge presented by implantation of stent-grafts within the aorta is how to maintain the position of the stent-graft precisely where desired. It is desirable to avoid or minimize the need for suturing through the walls of the aorta so that the aorta walls can remain unpenetrated, and to avoid stressing the walls of the aneurysm by utilizing a stent which provides too great of radial pressure outward on the wall of the aorta. The relatively high blood flow and blood pressure existing within the aorta puts forces upon the stent-graft which present the possibility of dislodging the stent-graft from its desired position. Additionally, differing patient luminal geometries can cause a stent-graft which is well designed for an average patient to be either too large, too small or the wrong shape to be effectively held in place without damaging the aorta once implanted. Also, when the aneurysm is at a location on the aorta where a significant lateral artery is located, such as one of the renal arteries, one of the iliac arteries, or arteries extending off of the aortic arch, a typical prior art stent-graft will tend to block or limit flow to such lateral arteries, decreasing blood circulation to these portions of the patient, and decreasing the effectiveness of the procedure.

Accordingly, a need exists for implantable devices which can function effectively as a stent-graft and which can be placed within the aorta or other body lumens adjacent an aneurysm or other defect which will properly fit within the body lumen, avoid placing undesirable stress upon the body lumen, hold the stent-graft in the desired position and maintain blood flow to major lateral arteries off of the aorta, or other lateral lumens off of a primary lumen in which the device is implanted.

BRIEF SUMMARY OF THE INVENTION

This invention provides a stent-graft which is configured to be securely anchored within a body lumen such as the aorta. The stent-graft can be in the form of a positioning anchor alone, or a combination of a positioning anchor and a stent-graft extending from the positioning anchor, or in the form of a stent-graft alone with some of the anchoring aspects according to this invention built into the stent-graft itself. The positioning anchor according to this invention is preferably a double walled generally tubular structure with a void between an inner wall and an outer wall of the anchor. A primary fluid conduit is thus defined by the inner wall of the anchor, providing the generally tubular structure for the anchor. Lateral fluid conduits are also preferably provided which extend laterally from the primary fluid conduit and out of the anchor.

In a preferred embodiment of this invention, the contour of the walls of the anchor is provided in a custom fashion matching the particular luminal geometry of the patient in which implantation is to occur. Hence, the size, shape and position of the lateral fluid conduits within arms extending from the anchor are preferably precisely positioned where needed to allow these arms of the anchor to extend at least partially into the lateral arteries or other lateral lumens located within the patient at the site where implantation is to occur. Radially expandable stents can circumscribe the arms of the anchor to secure the arms within lateral lumens within the patient.

The void between the inner wall and outer wall of the anchor is preferably fillable with a fixation media so that the anchor can be inflated, bringing the outer wall into contact with walls of the aorta or other body lumen at the implantation site. The fixation media can provide a rigidifying effect for the anchor, helping to maintain a geometry of the anchor within the aorta. Because the contour of the anchor matches the geometry of the patient at the implantation site, the anchor resists movement of the anchor, and any stent-graft coupled thereto, away from the implantation site.

Various different manufacturing methods are provided to form the walls of the anchor with the desired geometry, either with the anchor in a single walled form or in a double walled form. In the double walled form, the void can be totally open or can be spanned by interconnections functioning as “quilting” to maintain a maximum distance that the inner wall and outer wall can be spaced from each other. The anchor and other portions of the stent-graft can optionally be lined along the inner wall with a liner if such a liner is desired for the particular implantation procedure being conducted.

To provide the anchor and optionally a stent-graft coupled thereto with the desired geometry matching that of the aorta of the patient at the implantation site, the following procedure is preferably followed. Initially, patient luminal geometry is mapped utilizing imaging technology known in the art to create a data file corresponding with the patient’s luminal geometry. This data file can then be used to create a three-dimensional virtual model of the patient geometry as well as a desired geometry for the anchor, any stent-graft, and optionally a lumen shaper balloon to be utilized to precisely expand and support the anchor during expansion and inflation/fixation of the anchor. These models are then sent in digital form to a rapid prototyping (RP) machine to create actual models of these structures, such as the anchor and the shaper balloon. These models can then either be used directly as a mandrel/mold for the forming of the anchor and/or shaper balloon or used indirectly to make such mandrels/molds. Once the mandrels and/or molds have been made for the various components needed for the implantation procedure, the anchor, shaper and other equipment are formed by applying appropriate material for the formation of these structures against the mandrel and/or mold. Finally, the mandrel and/or mold is removed to provide the finished custom shaped anchor, shaper balloon or other structure for use in the implantation procedure.

Deployment can occur in any desired fashion, with intraluminal implantation considered most preferred. With such intra-luminal implantation, the lumen shaper balloon is collapsed upon a catheter with the anchor collapsed down upon the lumen shaper balloon. The catheter is then inserted as is known in the art into the aorta or other body lumen in an intra-luminal fashion.

When the catheter is properly positioned, typically with the assistance of imaging technology to verify its position, the lumen shaper balloon is expanded to cause the anchor to be expanded with arms of the anchor extending into the lateral lumens for proper support of the anchor. The lumen shaper balloon then remains inflated while the fixation media is delivered into the void between the inner wall and outer wall of the anchor, causing inflation of the anchor. The lumen shaper balloon maintains the position of the inner wall during such filling of the void, causing the outer wall to expand away from the inner wall until it comes into contact with the luminal wall of the patient or other tissues or deposits which may have collected within the lumen and are to be abutted by the outer wall of the anchor. Once this fixation media has been delivered, and optionally has been allowed to set through a

desired rigidity, the lumen shaper balloon can be deflated for removal of the lumen shaper balloon along with the catheter for completion of the procedure.

If a stent-graft is to be included along with the anchor, such a stent-graft can be implanted along with the anchor or in a secondary procedure with the stent-graft coupled to the anchor. The lumen shaper balloon can be configured to appropriately support the stent-graft and expand it into the desired position. If the stent-graft includes two walls with a void there between, fixation media can be utilized to fill this void in the stent-graft, either in a common procedure with the inflation of the anchor, or in a secondary procedure. Once any stent-graft has been properly positioned where desired and inflated with any fixation having taken place, any expansion shaper balloons on the catheter can be deflated and removed along with the catheter intraluminally out of the body lumen.

The implant including either the anchor alone, anchor and stent-graft or stent-graft alone remains in place with fluid flow through the lumen occurring through the interior tubular structure of the finally implanted structure, with the anchor or corresponding portions of the stent-graft fitting snugly within the patient’s luminal geometry to maintain proper position for the anchor and/or stent-graft. Proper fluid flow is thus maintained through the primary fluid conduit of the lumen, as well as maintaining fluid flow through the lateral lumen extending from the primary lumen through lateral fluid conduits within the anchor and/or stent-graft.

Accordingly, a primary object of the present invention is to provide a stent-graft which securely maintains its position within a body lumen while avoiding or minimizing penetration of the luminal wall and avoiding or minimizing stress placed upon the luminal wall.

Another object of the present invention is to provide a stent-graft which can support fluid flow through a body lumen main pathway while also maintaining fluid flow to lateral lumens coupled to the primary lumen.

Another object of the present invention is to provide a stent-graft which can fill at least a portion of a space within an aneurysm within a body lumen and provide a channel for fluid flow past the location of the aneurysm.

Another object of the present invention is to provide a stent-graft which can be customized in shape and form to match particular luminal geometry of a particular patient.

Another object of the present invention is to provide a stent-graft which can be delivered intraluminally and remain securely affixed at an implantation site.

Another object of the present invention is to provide methods for manufacturing stent-grafts which include an inner wall and an outer wall with a void therebetween.

Other further objects of the present invention will become apparent from a careful reading of the included drawing figures, the claims and detailed description of the invention.

BRIEF DESCRIPTION OF THE DRAWINGS

FIG. 1 is a perspective view of an anchor for a stent-graft or for use alone, according to this invention.

FIG. 2 is a full sectional front elevation view of that which is shown in FIG. 1.

FIG. 3 is a perspective view of that which is shown in FIG. 1 after inflation of a void between an inner wall and an outer wall of the anchor.

FIG. 4 is a full sectional view of that which is shown in FIG. 3 and including associated patient geometry surrounding the anchor.

FIG. 5 is a perspective view of a combination anchor and stent-graft and with the anchor shown inflated.

5

FIG. 6 is a full sectional view of that which is shown in FIG. 5 shown within patient anatomy, and revealing the single walled structure of the stent-graft of this embodiment along with the double walled structure of the anchor of this embodiment.

FIG. 7 is a full sectional view of a cavity mold revealing one method for forming a single walled anchor and/or stent-graft according to this invention.

FIG. 8 is a full sectional view of a mandrel mold for use in the formation of a single walled anchor and/or stent-graft according to this invention.

FIG. 9 is a full sectional view of a rotating mold which can be used to form a single walled form of the anchor and/or stent-graft according to this invention.

FIG. 10 is a perspective view of a sacrificial mandrel for use in the formation of the double walled anchor of FIG. 1.

FIG. 11 is a full sectional view of the sacrificial mandrel of FIG. 10.

FIG. 12 is a perspective view of the sacrificial mandrel revealing cut lines for the cutting of the mandrel into sections, as a first step in a quilting process to provide interconnections between an inner wall and an outer wall of an anchor formed with the sacrificial mandrel shown therein.

FIG. 13 is a perspective view of that which is shown in FIG. 12 after cutting of the mandrel into sections and at the beginning of a coating process for individual sections of the sacrificial mandrel.

FIG. 14 is a perspective view of the sacrificial mandrel after having been reassembled and receiving a second coating to form the anchor with quilting included therein.

FIG. 15 is a perspective view of the anchor with internal quilting not visible within an interior thereof.

FIG. 16 is a full sectional top plan view of the anchor and mandrel together and revealing the orientation of the quilting interconnection between the inner wall and the outer wall and with the sacrificial mandrel still included therein.

FIG. 17 is a perspective view of a quilting mandrel which includes slits therein to form quilting interconnections between the inner wall and the outer wall of the anchor after the quilting mandrel is coating with the material forming the anchor.

FIG. 18 is a full sectional top plan view of a portion of that which is shown in FIG. 15 or 17 after removal of the sacrificial mandrel from within the voids of the anchor and revealing one orientation for the quilting between the inner wall and the outer wall of the anchor.

FIG. 19 is a top plan view similar to that which is shown in FIG. 18, but illustrating thicker interconnections between the inner wall and the outer wall of the anchor.

FIG. 20 is a sectional top plan view similar to that which is shown in FIGS. 18 and 19, but with interconnections with irregular widths forming quilting between the inner wall and the outer wall of the anchor.

FIG. 21 is a perspective view of the quilting mandrel with a liner included therein.

FIGS. 22-24 reveal a sequence of steps associated with the positioning of the liner within the mandrel or onto an anchor after formation of the anchor upon the mandrel, especially when a double wall of the liner material is desired to be provided adjacent the inner wall of the anchor.

FIG. 25 is a perspective view of the lumen shaper balloon according to the preferred embodiment for use in expanding the anchor of this invention.

FIG. 26 is a flow chart identifying the sequence of steps in the formation of a custom anchor, lumen shaper balloon and/

6

or stent-graft with a particular geometry matching the particular luminal geometry of a patient to be treated with the device of this invention.

FIGS. 27-32 reveal steps in the process of delivering the anchor intraluminally to an implantation site.

FIG. 33 is a front elevation view in partial section of a human patient's aorta with a customized stent-graft with anchor according to this invention implanted therein.

FIG. 34 is a front elevation view in partial section of a patient's aorta with an anchor and stent-graft implanted therein especially at an aortic arch to treat an aneurysm therein.

FIG. 35 is a perspective view of a stent-graft with positioning anchor and with a portion of the stent-graft shown with a single walled and with a portion of the stent graft including separate toroidal sections in the form of double walls for at least a portion of the stent-graft.

FIG. 36 is a front elevation view of a patient with the stent-graft and anchor of FIG. 35 implanted within the patient and shown in full section.

FIG. 37 is a full sectional view of a portion of that which is shown in FIG. 36 adjacent where a single walled portion of the stent-graft is provided and where thrombus is present within an aortic aneurysm within the patient.

FIG. 38 is a perspective view of a custom configured combined stent-graft with positioning anchor for treatment of a particular patient's aortic aneurysm with a double walled anchor and single walled stent-graft indicated.

FIG. 39 is a front elevation view of a patient's anatomy with the stent-graft with positioning anchor of FIG. 38 implanted therein and shown in full section.

FIG. 40 is a top plan full sectional view of a portion of that which is shown in FIG. 39 revealing the position of the single walled stent-graft surrounded by thrombus within the aorta of the patient.

FIG. 41 is a perspective view of an alternative combination stent-graft with positioning anchor where both the positioning anchor and the stent-graft are formed together and are double walled in construction, having been custom manufactured to match a particular patient's arterial geometry.

FIG. 42 is a front elevation view of a patient's anatomy in section showing the stent-graft with positioning anchor of FIG. 41 in full section implanted therein, and particularly showing how stents are utilized to hold arms of the anchor in position relative to renal arteries of the patient and with the double walled stent-graft extending from the anchor.

FIG. 43 is a side elevation view of the aorta of the patient shown in FIG. 42, and revealing how the superior mesenteric artery is located relative to one of the renal arteries.

FIG. 44 is a perspective view of the stent-graft of FIG. 41 shown from a side so that the arms of the anchor positioned for insertion within the mesenteric arteries are shown, and with radially expandable stents thereon for holding of the arms of the anchor in the desired positions, along with a stent for supporting an upper end of the anchor.

DETAILED DESCRIPTION OF THE INVENTION

Referring to the drawings, wherein like reference numerals represent like parts throughout the various drawing figures, reference numeral 10 is directed to an anchor (FIGS. 1-4) for use either alone or in combination with a stent-graft 40 to treat a damaged lumen such as an aorta A (FIG. 4) by providing a primary fluid conduit 22 for bypass fluid flow through the damaged area. The anchor 10 includes arms such as renal arms 16, 18 which extend laterally for positioning within the renal arteries RA or other lateral arteries LA to assist in

maintaining a position of the anchor **10**. The anchor **10** can be inflated, such as with a fixation media **M** to secure the position of the anchor **10** within the aorta **A** or other body lumen. A stent-graft **40** (FIG. **5**) can be formed with or attached to the anchor **10** to further extend the primary fluid conduit for bypass fluid flow through the damaged portion of the aorta **A**.

In essence, and with particular reference to FIGS. **1-4**, basic details of the anchor **10** of this invention are described. The anchor **10** is preferably double walled including an inner wall **20** inboard of an outer wall **30** (FIG. **2**). A void **35** is provided between the walls **20**, **30**. Arms **16**, **18** preferably extend laterally from a primary fluid conduit **22** extending through the anchor **10**. When the void **35** is filled with fixation media **M** (FIG. **4**) the outer wall **30** expands away from the inner wall **20** (along arrow **B** of FIG. **2**) to fill a defect such as an aneurysm within the aorta **A** and to fix the position of the anchor **10**.

The arms **16**, **18** of the anchor **10** extend into lateral arteries such as the renal arteries **RA** to further assist in maintaining the desired position for the anchor **10**. The anchor **10** can be utilized alone or can have a stent-graft **40** (FIGS. **5** and **6**) attached thereto or formed therewith to extend the primary fluid conduit **22** as needed to bypass damaged portions of the aorta **A**. The stent-graft **40** can be single walled or double walled in form (FIGS. **41-44**) to help fill and support any aneurismal space which is desired to be filled within the aorta **A** or other body lumen in which the implant is positioned.

More specifically, and with particular reference to FIGS. **1-4**, particular details of the anchor **10** are described. The anchor **10** preferably has a geometry provided to match a geometry of the patient at the implantation site for the anchor **10**. The anchor **10** can either be manufactured to approximate typical patient geometry or custom manufactured as described in detail below, to match a particular patient's luminal anatomy at an implantation site. For ease of illustration, FIGS. **1-4** depict an anchor **10** of somewhat simplified typical geometry for an anchor **10** configured for implantation at a junction between the aorta **A** of the patient and renal arteries **RA** leading to kidneys **K** of the patient.

The anchor **10** preferably has a particular geometry as follows. The anchor **10** is preferably generally tubular in form surrounding a primary fluid conduit **22** between an upper end **12** and a lower end **14**. Multiple arms preferably surround lateral fluid conduits **24** extending away from the primary fluid conduit **22**. Such arms can include a superior mesenteric artery (SMA) arm **15** (FIG. **3**) and first and second renal arms **16**, **18**. These arms **15**, **16**, **18** are located where desired so that these arms **15**, **16**, **18** can extend at least partially into lateral arteries of the corresponding name within the patient.

The anchor **10** can be single walled to provide at least some of the desired function according to this invention, but is most preferably double walled in form. If the anchor **10** is single walled, it would typically be utilized in a patient which does not have an aneurysm or other defect at the location where the anchor **10** is to be implanted. The arms, such as the arms **15**, **16**, **18** of such a single walled anchor would be positioned into corresponding arterial pathways extending from the aorta or other lumen into which the anchor is to be implanted. Most preferably, radially expandable stents would be located adjacent these arms and radially expanded to bring such arms **15**, **16**, **18** of the anchor **10** into intimate contact with these lateral arteries. Additionally, a radial expandable stent can be utilized adjacent the upper end **12** and/or the lower end **14** to hold the ends **12**, **14** of the anchor **10** securely in contact with the wall of the aorta **A**. If desired, additional attachment structures could be utilized including sutures, staples, or other attachment structures known in the art to secure such a single

walled anchor at the desired implantation site. Such a single walled anchor according to this invention might support a single walled stent-graft, or a double walled stent-graft which would typically pass through a portion of the aorta **A** or other body lumen which is damaged. Such a single walled stent-graft would include a single wall which could merely extend the primary fluid channel away from the single walled anchor or could be provided as a separate piece configured to be attachable to such a single walled anchor, either outside of the patient or intraluminally during implantation of the single walled anchor and the stent-graft. The stent-graft **40** would typically have an upper end **42** (FIGS. **5** and **6**) for formation with the anchor **10** or for attachment to the anchor **10**.

According to the preferred embodiment, the anchor **10** is double walled, as particularly shown in FIGS. **1-4**, or with varying geometries to match a particular geometry of a particular patient at a specific desired implantation site, either within the aorta or in other arteries or body lumens where implantation is desired. With such a double walled anchor **10**, the anchor **10** is capable of undergoing an inflation and fixation procedure to assist in holding the anchor **10** in the desired implantation site location, and to fill an aneurysm or other defect space within the aorta **A** or other body lumen.

Specifically, after the anchor **10** has been positioned at the implantation site and oriented with the arms such as the arms **15**, **16**, **18**, passing into corresponding lateral arteries, a fixation matrix **M** is delivered into the void **35** between the inner wall **20** and the outer wall **30**. The inner wall **20** is preferably supported to prevent the inner wall **20** from collapsing inwardly into the primary fluid channel **22**. Such support is preferably provided by a lumen shaper balloon which has been inflated inboard of the inner wall **20**. One such lumen shaper balloon **110** is shown in FIG. **25** which could be utilized along with the anchor **10** of FIG. **1** during filling of the void **35** within the anchor **10**.

Because the inner wall **20** is prevented from collapsing inwardly, the void **35** can only expand to receive the fixation matrix **M** by having the artery wall **30** expand away from the inner wall **20**, along arrow **B** of FIG. **2**. This expansion can both cause the outer wall **30** to expand into an aneurismal space or other defect and to enlarge the overall size of the anchor **10** to prevent the anchor **10** from moving away from its desired implantation site.

As particularly shown in FIG. **4**, the anchor **10** has been expanded with the fixation matrix **M** so that the anchor **10** fills the space at the junction between the aorta **A** and the renal arteries **RA** such that the anchor **10** is securely held in position by the matching geometry between the anchor **10** and the patient geometry at that implantation site. Such a fixation methodology is generally analogous to the means by which a glove remains upon the hand due to matching geometry between inboard and outboard structures. This fixation methodology can be further enhanced by having the fixation media **M** formed of a material having a desired hardness which is either originally existing for the media **M** or which occurs in the media **M** after some transformation of the media **M**.

For instance, the media **M** could be initially presented into the void **35** in the form of a gas which undergoes a phase change or other transformation into a liquid or solid form either through a temperature change, a chemical reaction with agents located within the void **35** or a sufficient time for a gaseous matrix to set into a liquid or solid form. As another alternative, the fixation media **M** can be originally delivered as a liquid which could either remain liquid or undergo some level of firmness enhancement, such as by setting into a gel, or hardening into a solid, either by temperature change, chemical reaction or other setting procedure.

If necessary, or desirable, the media M could be delivered with multiple different components which would react together within the void 35 to solidify the media M within the void 35 to a desired level of firmness. Such firmness can both enhance the support with which the anchor 10 supports the wall of the aorta A, and can assist in holding the anchor 10 itself and any stent-graft 40 coupled to the anchor 10 fixed at the desired position within the patient.

The anchor 10 can be formed from a variety of different materials, either being formed from a single material or multiple different materials in combination. Most preferably, the material forming the anchor 10 is at least one layer of material which is impervious to fluid migration therethrough, either directly or by the inclusion of a fluid barrier liner, such as adjacent the inner wall 20 of the anchor 10. Most preferably, and to facilitate custom shaping of the contour of the anchor 10 to match the desired patient geometry at the implantation site, the anchor 10 is formed from a layer of moldable material. Such a moldable material could be in the form of a polymeric hydrocarbon. The anchor 10 itself, and/or an accompanying stent-graft 40 could be formed from parylene with a Dacron liner. The anchor 10 could be provided without a liner or formed entirely out of Dacron. Other materials exhibiting bio-compatibility and sufficient preclusion of fluid migration therethrough would also be suitable for formation of the anchor 10 and stent-graft 40 according to this invention.

The material forming the anchor 10 preferably is flexible to facilitate collapsing of the anchor 10 and the stent-graft onto a catheter for intra-luminal implantation. Such flexibility also assists in allowing the catheter to follow curving arterial pathways during intra-luminal delivery to the implantation site. Additionally, the material forming the anchor 10 and the stent-graft 40 is preferably substantially inelastic, at least within an operating range of pressures and forces with which the material encounters during implantation and function according to this invention. Some elasticity could be accommodated, provided that such an elasticity does not interfere with the function of the anchor 10 and stent-graft 40.

For particular discussion of the attributes of parylene and other materials from which the anchor 10 might be manufactured, particular reference is made to U.S. patent application Ser. No. 09/671,550, filed on Sep. 27, 2000, incorporated herein by reference.

The anchor 10 and other portions of the stent-graft 40 can be formed of any suitable method which provides the anchor 10 with the desired geometry and from the materials having the desired functional characteristics to function properly according to this invention. If the anchor 10 is to be formed in a single walled manner, one option includes use of a two-piece cavity mold 50 (FIG. 7), including an outer form 52 and an inner form 54. A cavity 56 between the forms 52, 54 is accessed through an entrance 58 for the material to enter the cavity mold 50. Such forming can generally be referred to as casting with the more specific manufacturing method utilizing such a mold including merely pouring the material into the mold, utilizing a vacuum to pull material into the mold, or utilizing some form of compression between the forms 52, 54 or compression or pressurization of the material at the entrance 58 to flow the material forming the anchor 10 entirely into the cavity mold 50.

With reference to FIG. 8, a mandrel mold 60 is provided which includes an inner mandrel 62 upon which a layer 64 of the material is deposited. Such material can be delivered, along arrow D of FIG. 8, to form the layer 64 upon the mandrel mold 60. Such delivery can occur by vapor deposition within a vacuum, dipping of the mandrel into fluid material for formation of the anchor 10 which can later harden, or

with utilization of vacuum forming, such as where a layer of the material is sucked onto the inner mandrel 62 by small vacuum holes formed within the inner mandrel 62.

With particular reference to FIG. 9, a rotating mold 70 is shown which includes an outer form 72 only, with an entrance 74 leading into a void within the outer form 72. A layer 76 is formed upon surfaces within the form 72. This layer 76 can be formed such as by filling the mold 70 with material through the entrance 74 and then spinning the mold 70 until a layer of the material with which the anchor is to be formed is applied to surfaces of the form 72 by forces applied along arrow E. Alternatively, vapor deposition can occur within the mold 70, gas pressure can be applied to blow the material against surfaces of the mold 70, or a vacuum forming technique can be utilized where small vacuum ports are included within the outer form 72 extending into the cavity within the mold 70 to suck the material forming the layer 76, typically originally provided in a solid sheet form, up against surfaces of the mold 70. Such techniques shown in FIGS. 7-9 are suitable for forming a single walled anchor, most particularly. With some modification, some of these manufacturing methods could similarly be utilized for forming at least one of the walls of a double walled anchor 10 or for formation of both the inner wall 20 and the outer wall 30 of such an anchor 10.

With particular reference to FIGS. 10 and 11, details of a sacrificial mandrel 80 are shown which can be utilized according to a preferred embodiment to form the double walled anchor 10 of this invention. The sacrificial mandrel 80 is essentially identical in size and contour to the void 35 of the anchor 10, such as that shown in FIGS. 1 and 2. Such a sacrificial mandrel 80 can be manufactured utilizing various suitable casting or other forming techniques.

Preferably, the sacrificial mandrel 80 would be formed of a material which can be readily destroyed for removal after formation of the double walled anchor 10 about the sacrificial mandrel 80, leaving the void 35 within the anchor 10. For instance, the sacrificial mandrel 80 can be formed of a water soluble material, so that once it comes into contact with water it liquefies and can be removed leaving the void 35 within the anchor 10.

As another alternative, the sacrificial mandrel 80 can be formed from a material which easily dissolves when an appropriate solvent is applied. For instance, the sacrificial mandrel 80 could be formed of a foam material, such as Styrofoam, which would react with a solvent such as acetone to pass entirely into solution and be poured out of the void 35 in the form of a liquid. Such removal of the sacrificial mandrel 80 would typically occur by forming a hole somewhere in the anchor 10 leading into the void 35, or removal of the sacrificial mandrel 80 after it has been so dissolved. Other alternatives include forming the sacrificial mandrel 80 from a material which can be readily oxidized, such as by combustion or otherwise gasified by a chemical reaction to allow the sacrificial mandrel 80 to be removed in the form of a gas out of the void 35 within the anchor 10.

As another alternative, the sacrificial mandrel 80 could be formed from a solid material, such as a wax, which has a suitable melting point so that it can merely be heated until it changes phase into a liquid or gaseous form, to then be removed from the void 35 within the anchor 10.

Similarly, the sacrificial mandrel 80 could be formed from an easily fracturable solid material, such that sharp blows to the anchor 10 with the sacrificial mandrel 80 included therein would cause the sacrificial mandrel 80 to shatter into small solid pieces which could be removed from an appropriate hole leading into the void 35 within the anchor 10. Such shattering could also be provided by appropriately tuned

11

vibrations, or ultrasonic waves, which might be directed at the sacrificial mandrel through the walls 20, 30 of the anchor 10.

While it is preferable that the sacrificial mandrel 80 be removed from the void 35, it is also conceivable that the sacrificial mandrel 80 would remain in some form within the void 35 and be implanted along with the anchor 10. For instance, if the sacrificial mandrel is formed of a collapsible foam material which has any resiliency and shape memory, it could be collapsed upon a catheter with an appropriate sheath to hold the anchor in its collapsed form. Once reaching the implantation site, the retraction of the sheath would cause such resilient foam to expand within the void 35 to the desired expanded position. If additional expansion is required, additional material could be provided along with the material forming the sacrificial mandrel 80, to further increase the size of the void 35 and/or to solidify the material forming the sacrificial mandrel 80 further, to enhance a firmness of the anchor 10. In such an embodiment, the sacrificial mandrel 80 would not necessarily be sacrificed, but rather remain in a position within the void 35 of the anchor 10.

With particular reference to FIGS. 12-16, details of a first quilting method are described which allows for the providing of interconnections between the inner wall 20 and outer wall 30 of the anchor 10 or corresponding portions of a double walled stent-graft, such as the toroidal sections of the stent-graft shown in FIGS. 35 and 41-44. When such interconnections are desired, the sacrificial mandrel 80 can be sliced along lines dividing the sacrificial mandrel 80 into separate sections 82 (FIG. 13). Such sections would be cut in orientations where the interconnection walls would be desired. Individual sections 82 would then be coated with a first coating 84 (FIG. 13) so that each section 82 of the sacrificial mandrel 80 is entirely coated with the material with which the anchor 10 is to be formed. Next, the sections 82 would be reassembled (FIG. 14) to again form the sacrificial mandrel 80 as it was originally constructed. A second coating 86 is then applied to the exterior of the outer wall 30 and the interior of the inner wall 20. This second coating 86 reattaches separate sections 82 of the sacrificial mandrel 80 back together. When the pieces of the original sacrificial mandrel 80 are later removed, multiple separate chambers are included within the void 35.

As described above, such interconnections can assist in resisting collapse of the inner wall 20 and constriction of the primary fluid conduit 22 during inflation of the void 35 with fixation media M. The finished anchor/mandrel combination 90 has a similar form (FIG. 15) as the sacrificial mandrel 80 (FIG. 10) and the desired finished construction for the anchor 10 (FIG. 1). However, the multiple interconnections extend between the inner wall 20 and outer wall 30, as particularly shown in the sectional view of FIG. 16. Hence, after the sacrificial mandrel 80 material has been removed, the sectional configuration of the anchor 10 can be as shown in FIG. 18. Alternatively, if the first coating 84 (FIG. 13) is thicker, than thicker interconnections provide wide quilting 106 between chambers in the void 35 (FIG. 19).

In accordance with a second quilting method, FIG. 17 provides a quilting mandrel 100 similar to the sacrificial mandrel 80 (FIG. 10) except that slits 102 are provided at various locations passing through the quilted mandrel 100. These slits 102 can have various different widths or tapering widths depending on whether thin quilting 105 (FIG. 18) is desired or wide quilting 106 (FIG. 19) is desired or whether tapered quilting 108 (FIG. 20) is desired.

When the quilting mandrel 100 is sprayed or vapor deposited with the material forming the anchor 10, some of the material passes through the slits 102 to form the quilting between the inner wall 20 and the outer wall 30 of the anchor

12

10. When the sacrificial quilting mandrel 100 is removed, the void 35 is provided with interconnection regions existing where the slits are provided within the quilting mandrel 100.

If desired, the anchor 10 can include a liner 104, such as adjacent the inner wall 20. Such a liner 104 is shown in FIG. 21 within the quilting mandrel 100. This liner 104 could be provided along with the quilting mandrel 100 so that formation of the walls 20, 30 occurs with the liner 104 in position to bond the liner 104 to the material forming the walls 20, 30. Alternatively, the liner 104 can be provided later after forming the inner wall 20 and outer wall 30 of the anchor 10 upon the sacrificial mandrel 80 or the quilting mandrel 100. Such a liner 104 can be attached to the anchor 10 before implantation of the anchor 10 or such a liner 104 can be provided during implantation or after implantation of the anchor 10.

Where a double walled liner 104 is desired, a rod 109 can be utilized to double back the liner 104 upon itself. Such a rod 109 can be one portion of a circular tube such that a double walled liner 104 becomes a quadruple walled liner 104, when the rod 109 is moved downwardly such as in FIGS. 22-24, or can be changed from a single walled liner 104 to a double walled liner 104 if the rod 109 is in the form of a single rod 109 between two liners 104.

The liner 104 can include holes therein adjacent where lateral arms are located within the anchor 10, or can be continuous in those locations in a fashion precluding blood flow to lateral arteries, if desired. For instance, if a lateral artery is not particularly needed for blood flow, such a lateral artery can merely be utilized as an anchoring point for the arms of the anchor 10, and not maintain blood flow therethrough. Preferably however, any liner 104 includes appropriate holes adjacent the arms of the anchor 10 so that blood flow is maintained through the lateral arteries adjacent where the anchor 10 is implanted.

With particular reference to FIG. 25, details of the shaper balloon 110 are described. As discussed above, the shaper balloon 110 is provided to expand the anchor 10 after translation of the anchor 10 with the catheter to the implantation site. The lumen shaper balloon 110 is also provided to support the inner wall 20 of the anchor 10 during inflation of the void 35 in the anchor 10 with fixation media M. The lumen shaper balloon 110 preferably includes a geometry matching generally that of the inner wall 20 of the anchor 10. The lumen shaper balloon 110 thus includes a top 112 spaced from a bottom 114. Arms 116 extend away from the exterior surface of the shaper balloon 110.

The shaper balloon 110 is preferably enclosed so that the top 112 and bottom 114 are enclosed with at least one access port for the delivery of an inflation fluid into the lumen shaper balloon 110. Preferably, knobs 118 are located at the ends of each of the arms 115 which are enclosed to allow the lumen shaper balloon 110 to be inflated without any holes where leakage would occur. These knobs 118 preferably inflate to a larger diameter than adjacent arms. The knobs 118 can be located adjacent where radially expandable stents are to be expanded between the anchor 10 and the lateral artery walls of the patient. The knobs 118 thus provide the radial force necessary to expand the radial expandable stent to the diameter desired. As an alternative, such radial expandable stents can be delivered in a separate procedure after general positioning of the anchor 10.

Preferably, the shaper balloon 110 is custom manufactured to a geometry matching a contour of the particular patient's body lumen geometry where the anchor 10 is to be implanted. Hence, a custom shaper balloon 110 is provided particularly adapted for expansion, inflation and proper positioning of the custom anchor 10 at the implantation site. The lumen shaper

balloon **110** would typically be a single walled structure, such that the manufacturing techniques particularly illustrated in FIGS. 7-9 and discussed in detail above would be suitable for formation of the lumen shaper balloon **110**.

With particular reference to FIG. 26, details of the process to be followed in custom manufacture of the anchor **10**, the lumen shaper balloon **110** and any custom manufactured stent-grafts **40** are described. Initially, patient imaging information in the form of X-rays, computer tomography (CT) scans, ultrasound data, magnetic resonance imaging (MRI) data or other imaging data are acquired and converted into a data file such as that which can be read by a computer aided drafting (CAD) file or other corresponding data coding methodology. This imaging information can be viewed, such as by a physician or other medical treatment planners to determine how best to treat any defects in the body lumens being imaged.

On computer displays viewing the data, the treatment planner can construct a desired geometry for the anchor **10** and/or stent-graft **40** which would match the particular patient's luminal geometry at the treatment site. Some or all of this process of constructing a desired geometry for the anchor **10** and/or the stent-graft **40** could similarly occur in an automated fashion by a computer recognizing the geometry of the patient's body lumen and taking appropriate measurements to construct a desirable anchor **10** and/or stent-graft **40**.

Once such virtual models of the anchor **10** have been created, an automated or manual process can be utilized to define desired geometry for the lumen shaper balloon **110** to be utilized in positioning and expanding the anchor **10**. These virtual models also digitally describe the geometry of mandrels and/or molds to be used in forming the actual devices which will be used in the implantation procedure.

Data files corresponding with the geometry of the desired anchor **10** and desired lumen shaper balloon **110** are then sent to a rapid prototyping (RP) machine, such as that provided by Z-Corp or 3-D Systems. The rapid prototyping machine then creates actual three-dimensional models, preferably of full size, for the anchor **10** and the lumen shaper balloon **110**. These 3-D models of the anchor **10** and lumen shaper balloon **110** can then either be used directly or indirectly to form mandrels or other molds which will then be used in formation of the final anchor **10** and lumen shaper balloon **110**.

Finally, in the case of a sacrificial mandrel **80**, the mandrel is removed as is discussed in detail above to provide voids **35** where desired within the anchor **10**. The final shaper balloon **110** and anchor **10** can then be collapsed upon a catheter or other deployment device for use in the implantation procedure, to be delivered to the implantation site.

With particular reference to FIGS. 27-32, the preferred method for intra-luminal implantation of an anchor **150**, similar to that of the anchor **10**, is described. In these figures, a lateral view is provided with the primary fluid conduit extending vertically in the foam of a human patient's aorta and with lateral arteries in the form of the superior mesenteric artery (SMA) and a second lateral artery LA, such as the inferior mesenteric artery. Renal arteries are not shown in this sectional view, but would typically also be included in the geometry of the anchor **150** and shaper balloon **160**.

Initially, a delivery catheter **120** is provided which includes the shaper balloon **160** collapsed upon the delivery catheter **120** and with the anchor **150** overlying and collapsed upon the shaper balloon **160**. A sheath **140** overlies the anchor **150** and shaper balloon **160** to assist in holding the shaper balloon **160** and anchor **150** in their collapsed configuration.

The delivery catheter **120** can then be fed through an insertion site, such as in the femoral artery of one of the legs of the

patient, up to the aorta A or other implantation site. A guide wire **122** is preferably provided to assist in steering the delivery catheter **120** along the desired arterial pathway up to the aorta A. Once the delivery catheter **120** has reached the implantation site where an aneurysm X exists, and adjacent the lateral arteries to which the anchor **10** has been custom manufactured, the delivery catheter **120** is then rotated to the desired orientation. Radiopaque markers can be included upon the delivery catheter **120**, the sheath **140** or upon the anchor **150** or shaper balloon **160** to determine both the position of the delivery catheter **120** and the orientation of the delivery catheter **120**.

The sheath **140** is then retracted to expose the anchor **150**. Preferably, a seal balloon **130** is provided near a tip of the delivery catheter **120**. This seal balloon **130** can be initially inflated, such as through a fluid delivery conduit within the delivery catheter **120** and with an outlet at the seal balloon **130**. The seal balloon **130** can thus be expanded to block off the aorta A. Preferably, a tip of the delivery catheter **120** includes a bypass inlet **124** to a hollow center of the delivery catheter **120**, or other pathway extending to the bypass outlet **126**. In this way, blood flow F can be diverted through the delivery catheter **120** during the positioning, expansion and inflation procedure for the anchor **150**.

The shaper balloon **160** is then inflated by delivery of an appropriate inflation fluid into the shaper balloon **160**. This causes the anchor **150** to be expanded to its fully expanded (but uninflated) form (FIG. 29). As inflation of the shaper balloon **160** occurs, arms **152** in the anchor **150** begin to protrude with the assistance of the arms **162** of the shaper balloon **160**. The delivery catheter **120** can be further rotated if necessary to make sure that the arms **152** are oriented where desired so that the arms **152** feed into the lateral artery LA and superior mesenteric artery SMA for proper positioning of the anchor **150**. When the shaper balloon **160** has been fully inflated, the entire aneurysm X has not typically been entirely filled. However, the arms **152**, of the anchor **150** should extend into the lateral arteries LA extending off of the aorta A.

If desired, a collar **170** can be provided within the anchor **150** which is in the form of a separate void which can be initially filled to provide added structure to the anchor **150** and to further assist in preventing the anchor **150** from slipping within the aorta A. Such filling of the collar **170** can occur through a filler tube **172** leading to the collar **170**. Once the expanded but uninflated anchor **150** is properly positioned with its arms **152** extending into the lateral arteries extending through the aorta A, the anchor **150** is ready for inflation.

Fixation media M is then delivered through the media delivery tube **180** (FIG. 31) to expand the outer wall **156** away from the inner wall **154** and fill the void **155** between these walls **154**, **156**. As discussed in detail above, the fixation media M is then allowed to harden to the desired firmness according to the type of fixation media M utilized. If desired, radial expandable stents can be radial expanded within the arms **152** of the anchor **150** to secure the arms **152** where desired within lateral arteries, and/or adjacent an upper end and/or a lower end of the anchor **150**.

Finally, the lumen shaper balloon, which has remained inflated to ensure that the primary fluid conduit through the anchor **150** remains fully open during setting and filling of the void **155** with the media M, can be deflated along with the seal balloon **130**. The delivery catheter **120**, fill balloon **130** and lumen shaper balloon **160** can then be retracted out of the anchor **150**.

If portions of a stent-graft are coupled to the anchor **150**, they can be inflated before movement of the delivery catheter **120**, or with a balloon such as the seal balloon **130** utilized to

expand the stent-graft as the delivery catheter **120** is retracted. Once the delivery catheter **120** and lumen shaper balloon **160** has been removed, blood flow F' occurs through the anchor **150** and with blood allowed to flow through the lateral arteries coupled to the aorta A at the implantation site.

While this implantation procedure has been particularly described with regard to the anchor **150** being inflated at a junction of the aorta A and renal arteries RA , a similar procedure could be utilized for delivery of an anchor to the aortic arch, or to a location above the renal arteries, or to a location below the renal arteries, depending on the particular treatment plan indicated for the patient's condition. An analogous delivery procedure would be utilized for the expansion and inflation of a double walled stent-graft according to this invention with the exception that no arms would be included which would require positioning into lateral arteries. Such a stent-graft can be provided along with the anchor or implanted in a separate follow-up procedure after positioning of the anchor.

With particular reference to FIGS. **33-44**, various particular examples are provided of different luminal defects, and particularly aortic aneurysms, with varying implants in the form of anchors and stent-grafts provided to treat such typical hypothetical cases. With particular reference to FIG. **33**, an aneurysm X is presented within an aorta A which is primarily below the renal arteries RA and above the iliac arteries IA , but close to the iliac arteries IA . This aneurysm X includes a significant amount of thrombus T in at least one portion of the aneurysm X . A stent-graft with renal anchor **200** is custom manufactured to have a geometry similar to that depicted in FIG. **33**.

Specifically, the anchor portion is generally in the form of a single walled anchor which includes stents **210** in arms of the anchor which extend into the renal arteries, the superior mesenteric artery SMA and other lateral arteries LA . Additional stents **210** support upper and lower ends of the anchor adjacent walls of the aorta A .

A series of toroids are manufactured along with the stent-graft portion of the implant **200**. These toroids are generally similar to those shown in the stent-graft with positioning anchor **600** of FIGS. **41-44**. Once these toroidal sections have been filled with fixation media M , they fill portions of the aneurysm X which are not already filled with thrombus T . A final channel is provided which extends through the aneurysm X down to the iliac arteries IA . In this case, the stent-graft portion splits into two separate channels to feed each of the iliac arteries IA separately. Stents can be provided at the ends of these separate channels to support the lower most ends of the implant **200**.

With particular reference to FIG. **34**, a stent-graft with aortic arch anchor **300** is depicted. In this example, the patient's aortic arch and portions of the aorta above the renal arteries includes an aneurysm therein. The position of the patient's heart H is shown in broken lines for reference. The aneurysm X both exists within the aortic arch and below the aortic arch. An anchor is provided which includes two walls so that the anchor portion of the implant can be expanded, as well as toroidal sections on the stent-graft portion of the implant **300**. The aortic arch anchor is custom manufactured to have lateral artery arms positioned where desired to match the particular patient geometry, so that the aortic arch anchor, once expanded, will securely hold both the anchor and the stent-graft in the desired position. Media M fills both the void within the aortic arch anchor and in the stent-graft, extending from the aortic arch anchor to fill excess space within the aneurysm X .

With particular reference to FIGS. **35-37**, a third example is provided. In this example, the patient has an aortic aneurysm which includes both a junction between the aorta and the renal arteries and an aneurysm X extending down to near the iliac arteries IA . However, a sufficient amount of thrombus T exists in a midpoint of the aneurysm that the stent-graft portion of the proposed implant **400** need only be a single walled stent-graft at upper portions thereof. Lower portions of the stent-graft include toroidal fillable sections so that the stent-graft is double walled in this lower region.

Also, the anchor portion of the implant **400** is double walled, similar to the embodiment of FIGS. **3** and **4**. This example illustrates how portions of the aneurysm X can be filled with media within the anchor and portions of the aneurysm X can be filled with media through the toroids on the stent-graft, with still further portions of the aneurysm X filled with the thrombus T already existing within the aneurysm X , and with potentially other portions of the aneurysm X remaining unfilled where it is deemed that such a void is not disadvantageous. In this embodiment the aneurysm stops sufficiently short of the iliac arteries IA . Hence, a single tubular ending to the stent-graft is custom provided for termination of the lower end of the implant **400**. FIG. **37** provides a cross-section of a portion of the stent-graft which is single walled, and illustrating how the thrombus T can act to support the stent-graft within the aorta A .

FIGS. **38-40** provide a fourth example for the function of the invention of this application. In this example, the patient has an aneurysm with a significant amount of thrombus T in the lower portion thereof, but without a significant amount of thrombus near the junction with the renal arteries RA . In this example, a stent-graft with positioning anchor **500** is manufactured as shown in FIG. **38**. This stent-graft with positioning anchor is configured to utilize the renal arteries primarily for anchoring of the anchor and the stent-graft portions of the implant **500**.

Fixation media M is utilized to expand the anchor portion of the implant **500** to fill the void adjacent the renal arteries RA . Because lower portions of the aneurysm X include a significant amount of thrombus T which is already effectively positioned to support the stent-graft portion of the implant **500**, the stent-graft portion can be merely a single walled stent-graft extending entirely down from the anchor portion of the implant **500**, without any toroidal sections which require any filling. In this example the stent-graft is shown with dual tubes at lower ends extending into each of the iliac arteries IA . FIG. **40** again illustrates a cross-section where the stent-graft portion of the implant **500** is supported by thrombus T .

FIGS. **41-44** show a fifth example where an implant **600** in the form of custom stent-graft with renal artery anchor is provided according to this invention. In this example, a stent-graft with positioning anchor is custom manufactured to match the patient's particular geometry, in a situation where an aneurysm X exists both at the junction of the aorta with the renal arteries RA and with the aneurysm X extending below the junction with the renal arteries RA . Insufficient thrombus T exists to provide adequate support for the stent-graft portion extending below the anchor portion of the implant **600**. Hence, a series of toroids are included on the stent-graft portion which can be separately filled with fixation media M similar to the inflation of the anchor portion of the implant **600**.

In FIG. **42** radially expandable stents **610** are shown to illustrate how the anchor portion of the implant **600** is held both within the renal arteries RA and within the aorta A (FIG. **42**). FIG. **43** clearly illustrates the geometry of the aneurysm

X from a side view with FIG. 44 showing the implant 600 from a side view to further illustrate the positioning of stents 610, particularly for use in holding the various arms of the anchor portion of the implant 600 within lateral arteries to secure the anchor portion of the implant 600 in the desired implantation position within the patient.

This disclosure is provided to reveal a preferred embodiment of the invention and a best mode for practicing the invention. Having thus described the invention in this way, it should be apparent that various different modifications can be made to the preferred embodiment without departing from the scope and spirit of this invention disclosure. When structures are identified as a means to perform a function, the identification is intended to include all structures which can perform the function specified. When structures of this invention are identified as being coupled together, such language should be interpreted broadly to include the structures being coupled directly together or coupled together through intervening structures. Such coupling could be permanent or temporary and either in a rigid fashion or in a fashion which allows pivoting, sliding or other relative motion while still providing some form of attachment, unless specifically restricted.

What is claimed is:

1. A method for deploying a double walled anchor intraluminally at an intersection of a main vessel and at least two branch vessels, the anchor inflatable with a fixation media, the deployment method including the steps of:

providing the anchor, the anchor comprising an inner wall surrounding and defining a primary fluid conduit having an upper opening and a lower opening, an outer wall outside of an exterior of the inner wall, and a fillable void between the inner and outer wall, wherein the inner and outer walls further form at least two arms extending laterally outward from the primary fluid conduit between the upper and lower opening, the inner wall of each arm surrounding and defining at least one lateral fluid conduit in fluid communication with the primary fluid conduit, and wherein the fillable void surrounds the primary fluid conduit, extends into each arm and surrounds each lateral fluid conduit;

collapsing the anchor onto a catheter;

advancing the catheter from a lumen insertion point to an implantation site for the anchor;

expanding the inner wall and the outer wall of the anchor away from the catheter to a desired position for the inner wall so as to facilitate blood flow of the main vessel through the primary fluid conduit after deployment;

expanding each arm of the anchor into a separate branch vessel;

expanding the inner wall of each arm to a desired position for the inner wall so as to facilitate blood flow from the primary fluid conduit through the lateral fluid conduits into the branch vessels after deployment of the anchor; and

substantially filling a space between an outside surface of the outer wall and a wall of each of the main vessel and the branch vessels at the intersection of the main and branch vessels by filling the fillable void between the inner wall and the outer wall with the fixation media to inflate the anchor thereby expanding the outer wall to contact the walls of the main vessel and branch vessels.

2. The deployment method of claim 1, including the further step of supporting the inner wall adjacent an inside surface of the inner wall during said filling step, such that a position of the inner wall is not deflected inward during said filling step.

3. The deploying method of claim 2, wherein said supporting step includes the step of positioning a lumen shaper balloon inside of the inner wall of the anchor during said filling step.

4. The deploying method of claim 3, wherein said expanding step includes the step of inflating the lumen shaper balloon inside of the inner wall until the inner wall and the outer wall are expanded away from the catheter to the desired position for the inner wall, said lumen shaper balloon remaining inflated and adjacent the inner wall during said filling step to provide support for the inner wall.

5. The method of claim 4, wherein inserting each arm into a separate branch vessel comprises inflating a lumen shaper balloon so that at least two portions of the balloon corresponding to the at least two branch vessels expand toward the branch vessels thereby inserting each arm into a corresponding branch lumen.

6. The method of claim 4, wherein expanding the inner wall of each arm comprises inflating the lumen shaper balloon inside of the inner wall until the inner wall is expanded to the desired position for the inner wall so as to redefine a blood flow lumen through the each branch vessel.

7. The deploying method of claim 1, including the further step of allowing the fixation media to set from a more fluid form to a less fluid foam.

8. The deployment method of claim 1, including the further step of diverting fluid flow from passage through the main vessel and branch vessels at the implantation site to a pathway through the catheter, at least during said expanding step and said filling step, such that fluid flow through the main vessel and branch vessels continues.

9. The deployment method of claim 1, including the further step of providing a lumen shaper balloon having a deflated lesser diameter form and an inflated greater diameter form, said inflated greater diameter form having a contour at least partially matching a contour of the anchor adjacent the lateral conduit of the anchor, such that transition of the lumen shaper balloon from the deflated form to the inflated form during said expanding step causes the arm of the anchor adjacent the lateral conduit to be expanded into a lateral lumen extending from a primary lumen in which the implantation site is located.

10. The deployment method of claim 9, including the further steps of:

positioning a radially expandable stent on each of the at least two arms of the anchor and expanding each radially expandable stent until said radially expandable stent assists in engaging each of the at least two arms of the anchor with a branch vessel at the implantation site for the anchor.

11. The deployment method of claim 2, including the further step of coupling a graft to the anchor, the graft having a tubular form surrounding the primary fluid conduit and extending the primary fluid conduit beyond the anchor.

12. The deployment method of claim 11, wherein said coupling step precedes said collapsing step, such that said graft is coupled to the anchor before implantation thereof.

13. The deployment method of claim 12, including the further step of forming the graft together with the anchor before said collapsing step.

14. The deployment method of claim 12, including the further step of attaching the graft to the anchor before said implantation step.

19

15. The deployment method of claim 11, wherein said coupling step occurs after said advancing step, said coupling step including the step of attaching the graft to the anchor after the anchor has been located at the implantation site for the anchor.

16. The method of claim 1 wherein filling the void between the inner wall and the outer wall with the fixation media expands the outer wall to contact to an inside surface of an aneurysm substantially filling an aneurysmal space occurring at the intersection of the main vessel and branch vessels, thereby forming a redefined blood flow through the aneurysm and supporting the filled aneurysm.

17. The method of claim 1, wherein the void between the inner and outer wall extends over a majority of the inner and outer walls.

18. The method of claim 17, wherein the void between the inner and outer wall extends over substantially the entire inner and outer walls.

20

19. The method of claim 1, further comprising: engaging the outer wall of the anchor so that a majority of the outside surface of the outer wall contacts the walls of the at least two branch vessels and the wall of the main vessel and/or aneurysm to securely hold the anchor at the implantation site.

20. The method of claim 1, further comprising: filling an aneurysmal space between an inside surface of an aneurysm and the outside surface of the outer wall by filling the fillable void with the fixation media thereby expanding the outer wall outward toward the inside surface of the aneurysm.

21. The method of claim 1, wherein the anchor comprises an upper end adjacent the upper opening and a lower end adjacent the lower opening and further comprising expanding a stent adjacent the upper and/or lower end of the anchor to hold the upper and/or lower end of the anchor securely in contact with the wall of the main vessel.

* * * * *