

US009103080B2

(12) **United States Patent**
Jolicoeur et al.

(10) **Patent No.:** **US 9,103,080 B2**
(45) **Date of Patent:** **Aug. 11, 2015**

(54) **ARTICULATING WORK PLATFORM SUPPORT SYSTEM, WORK PLATFORM SYSTEM, AND METHODS OF USE THEREOF**

(75) Inventors: **Paul Jolicoeur**, Troy, NY (US); **Roy Scrafford**, Scotia, NY (US); **Clifford Westrick**, Albany, NY (US); **Dave Gordon**, Schenectady, NY (US); **Tom Silic**, Saratoga Springs, NY (US); **Edward Tifft**, N. Bennington, VT (US); **Mathieu Grumberg**, Delmar, NY (US)

(73) Assignee: **SAFWAY SERVICES, LLC**, Waukesha, WI (US)

(*) Notice: Subject to any disclaimer, the term of this patent is extended or adjusted under 35 U.S.C. 154(b) by 0 days.

(21) Appl. No.: **13/106,958**

(22) Filed: **May 13, 2011**

(65) **Prior Publication Data**

US 2011/0214945 A1 Sep. 8, 2011

Related U.S. Application Data

(60) Continuation of application No. 12/853,921, filed on Aug. 10, 2010, now Pat. No. 7,941,986, and a division of application No. 10/814,945, filed on Mar. 31, 2004, now Pat. No. 7,779,599.

(51) **Int. Cl.**

E04H 12/00 (2006.01)
E01D 19/10 (2006.01)
E04G 1/34 (2006.01)

(Continued)

(52) **U.S. Cl.**

CPC **E01D 19/106** (2013.01); **E04G 1/34** (2013.01); **E04G 3/30** (2013.01); **E04G 5/14** (2013.01); **Y10T 29/49826** (2015.01); **Y10T 29/49947** (2015.01); **Y10T 403/32106** (2015.01)

(58) **Field of Classification Search**

USPC 52/169.12, 634, 646, 647, 648.1, 650.3, 52/651.1, 656.9, 633, 636, 641, 653.1, 52/654.1, 655.1, 693, 64, 65, 220.1, 52/745.19, 745.2; 182/141, 142, 150; 403/169, 170, 178, 217, 218

See application file for complete search history.

(56) **References Cited**

U.S. PATENT DOCUMENTS

748,962 A 1/1904 Lewis
1,819,032 A 8/1931 Kuhlman
2,303,428 A 12/1942 Black

(Continued)

FOREIGN PATENT DOCUMENTS

AU 200138987 B2 11/2001
CA 2824872 A1 5/2013

(Continued)

OTHER PUBLICATIONS

Examination Report of the European Patent Office; Application No. 05730794.4; dated Jul. 25, 2012; 5 pages.

(Continued)

Primary Examiner — William Gilbert

(74) *Attorney, Agent, or Firm* — Whyte Hirschboeck Dudek S.C.

(57) **ABSTRACT**

The invention includes a work platform and support system that includes a hub and joist configuration, wherein the hubs and joists are capable of articulation, or pivoting. One method of installation allows for sections of new work platform system to be extended from an existing suspended work platform system. The system is also capable of supporting, without failure, its own weight and at least four times the maximum intended load applied to it.

63 Claims, 30 Drawing Sheets

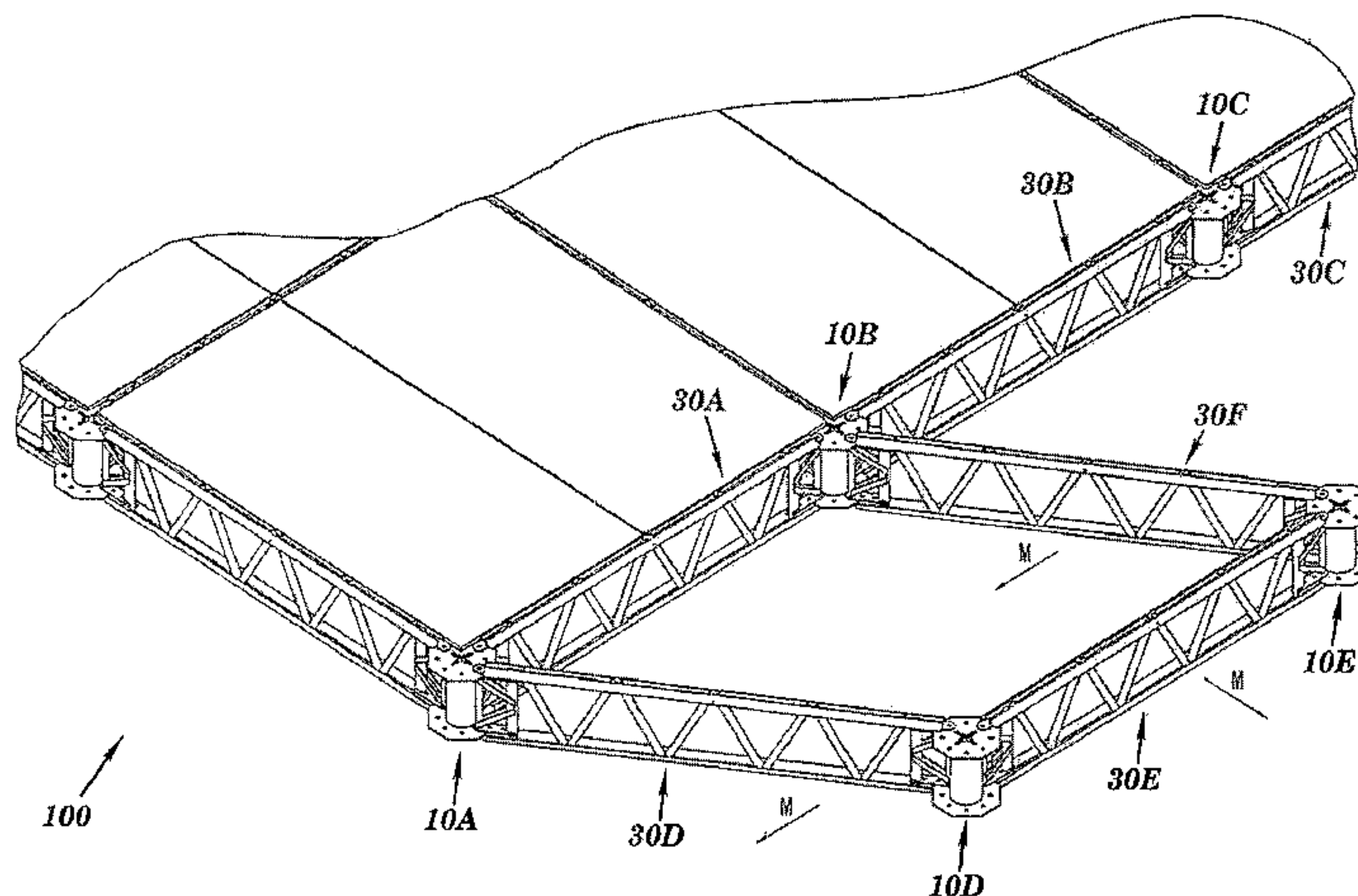

- (51) **Int. Cl.**
E04G 3/30 (2006.01)
E04G 5/14 (2006.01)

(56) **References Cited**

U.S. PATENT DOCUMENTS

2,882,099	A	4/1959	Symons	
2,903,282	A	9/1959	Wright	
2,987,148	A	6/1961	Millard	
2,994,402	A	8/1961	Tyler	
3,420,011	A	1/1969	Takahashi	
3,425,179	A	2/1969	Haroldson	
3,635,509	A	1/1972	Birkemeier et al.	
4,058,184	A	11/1977	Stuart et al.	
4,244,152	A *	1/1981	Harper, Jr.	52/81.3
4,445,307	A	5/1984	Puccinelli et al.	
4,566,245	A	1/1986	Ruter	
4,574,535	A	3/1986	Pabsch	
4,624,374	A	11/1986	Murtaugh	
4,660,680	A	4/1987	Potin	
4,671,382	A	6/1987	D'Alessio et al.	
4,685,535	A	8/1987	Bush et al.	
4,815,563	A	3/1989	Puccinelli et al.	
4,922,669	A *	5/1990	De Pas et al.	52/646
4,958,845	A *	9/1990	Parks	280/407.1
5,028,164	A	7/1991	Williams	
5,078,532	A	1/1992	Williams	
5,203,428	A	4/1993	Beeche	
5,207,527	A	5/1993	Duncan et al.	
5,214,899	A	6/1993	Beeche et al.	
5,274,980	A	1/1994	Zeigler	
5,301,770	A	4/1994	Regan et al.	
5,343,978	A	9/1994	VanAmburg	
D366,531	S	1/1996	Wedge	
5,771,655	A	6/1998	Strickland et al.	
6,223,482	B1	5/2001	Zohar	
6,386,319	B2	5/2002	Apostolopoulos	
7,726,447	B2	6/2010	Kawaguchi et al.	
7,971,686	B1	7/2011	Hayman	
8,123,001	B1	2/2012	Apostolopoulos et al.	
8,206,052	B1	6/2012	Hayman	
8,303,207	B2	11/2012	Thacker	
8,393,439	B2	3/2013	Thacker	
2002/0059770	A1 *	5/2002	Fritsche et al.	52/645
2004/0020138	A1	2/2004	Grearson	
2004/0128492	A1	7/2004	Wang	
2004/0211147	A1	10/2004	Vanagan	
2007/0187179	A1	8/2007	Simoes	
2009/0052980	A1	2/2009	Williams	
2010/0175951	A1	7/2010	Winson et al.	
2011/0180350	A1	7/2011	Thacker	
2011/0262215	A1	10/2011	Thacker	
2012/0186910	A1	7/2012	Thacker et al.	
2012/0186911	A1	7/2012	Thacker et al.	
2013/0043095	A1	2/2013	Thacker	
2013/0142564	A1	6/2013	Thacker	

FOREIGN PATENT DOCUMENTS

DE	202012008975	U1	2/2014
EP	1785549	A1	5/2007
EP	1921222	A1	6/2007
EP	1978180	A2	8/2008

EP	2031150	A2	3/2009
EP	ES2354336		3/2011
EP	2354375	A1	8/2011
JP	S63-066989		12/1988
NZ	587700	A	3/2012
WO	WO2009123567	A2	10/2009
WO	WO2010045963	A1	4/2010
WO	WO2011094351	A2	8/2011
WO	WO2012102881	A1	8/2012
WO	WO2013066859	A1	5/2013

OTHER PUBLICATIONS

Office Communication; Canadian Patent Application No. 2,561,444; Feb. 16, 2012; 2 pages.
 Examination report for Canadian patent application No. 2,821,556 dated Jun. 25, 2014, 3 pages.
 Runback Component Identification Engineering Drawings, Safway Services, Inc., dated May 19, 2013, 1 page.
 Runback Development Engineering Drawings, Safway Services, Inc., dated Aug. 10, 2003, 1 page.
 Next Generation Products Information Page, SafeDeck: http://www.nextgenscaffold.com/index.php?option=com_content&view=article&id=18&Itemid=35, 1 page, printed Oct. 31, 2014.
 SafeDeck Motor YouTube video: <http://www.youtube.com/watch?v=Alqe-uGcnel>; posted on Feb. 28, 2014.
 PERI Formwork Systems Inc., PERI UP Scaffold Units, product page, url: http://www.peri-usa.com/products.cfm/fuseaction/diashowlproduct_ID/138/currentimage/6/, printed Jul. 2, 2014, 1 page; PERI UP Scaffold Units believed to be publicly and/or commercially available and/or sold circa 1995.
 DSS Direct Scaffold Supply Product Catalog, updated Mar. 5, 2012, 96 pages; product on cover page of catalog believed to be publicly and/or commercially available and/or sold circa 1996.
 Safway Group Safflock System Scaffold Technical Manual, revised Nov. 2014, 72 pages; Safflock product believed to be publicly and/or commercially available and/or sold circa 2003.
 Safway Systems Scaffold Product Selection Guide, revised Nov. 2012, 20 pages; Systems Scaffold Product believed to be publicly and/or commercially available and/or sold circa 1983.
 Safway Tube & Clamp Scaffold Product Selection Guide, revised Nov. 2012, 10 pages; Tube & Clamp Scaffold product believed to be publicly and/or commercially available and/or sold circa 1960's.
 Layher Allround Scaffolding brochure, Layher AllroundTechnology, 10 pages; Layher Allround Scaffolding believed to be publicly and/or commercially available and/or sold circa 1974; retrieved from url: <http://www.layherco.uk/brochures.aspx>.
 Layher Allround Scaffolding brochure, For All-Round Use in Building Work, 6 pages; Layher Allround Scaffolding believed to be publicly and/or commercially available and/or sold circa 1974; retrieved from url: <http://www.layher.co.uk/brochures.aspx>.
 QES Simplicity is the Key product sheet; QES believed to be publicly and/or commercially available and/or sold circa 1983.
 WACO Scaffolding & Equipment, System Scaffolding brochure dated 2010, WACO system scaffolding shown on first page believed to be publicly and/or commercially available and/or sold circa 1983.
 Layher Allround Scaffolding System Catalogue 2008; Layher Allround Scaffolding believed to be publicly and/or commercially available and/or sold circa 1974.
 Patent Construction Systems, Safety Rules and Instructions #910 for QES Quick Erect Scaffold, 1993.

* cited by examiner

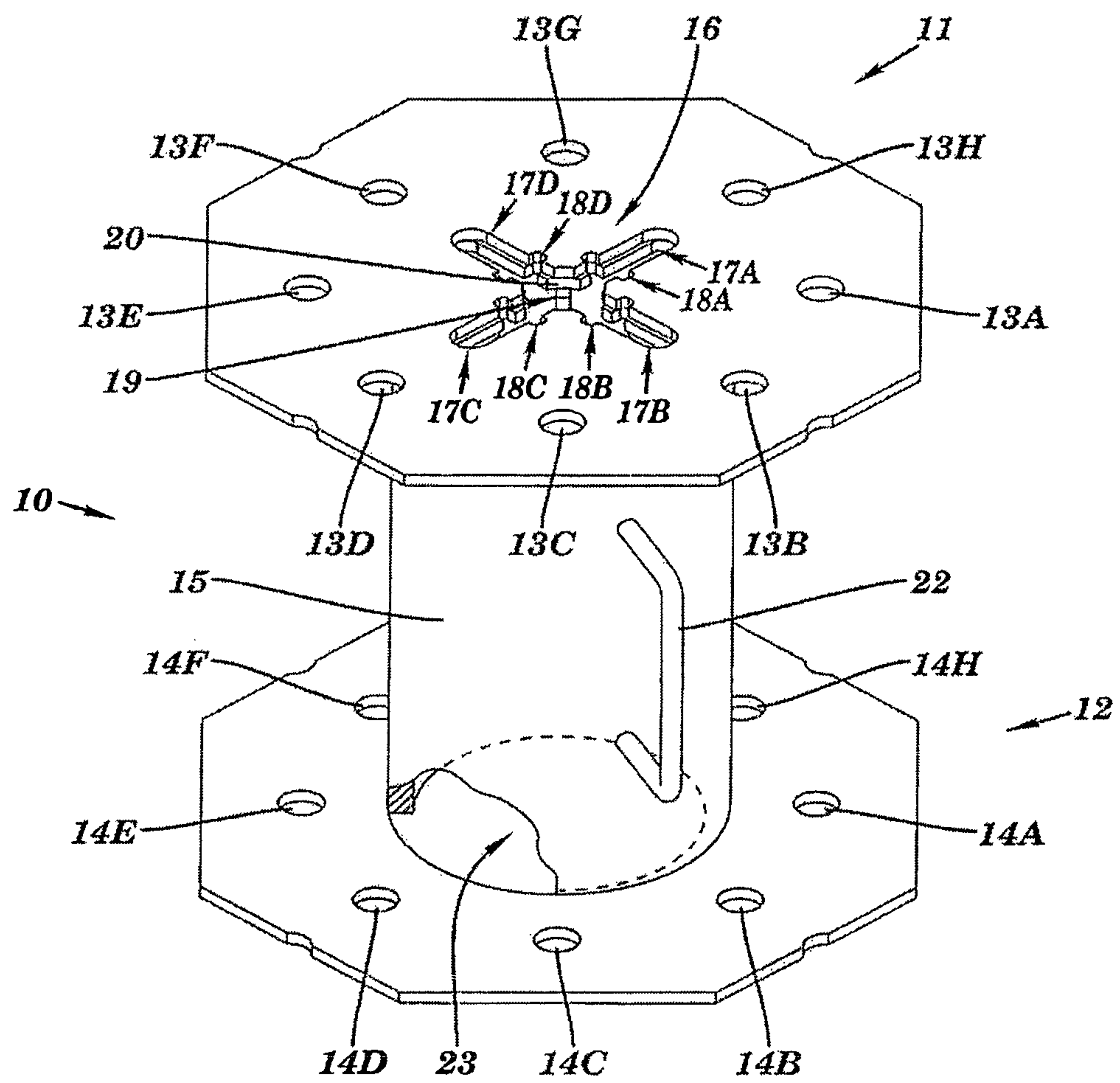
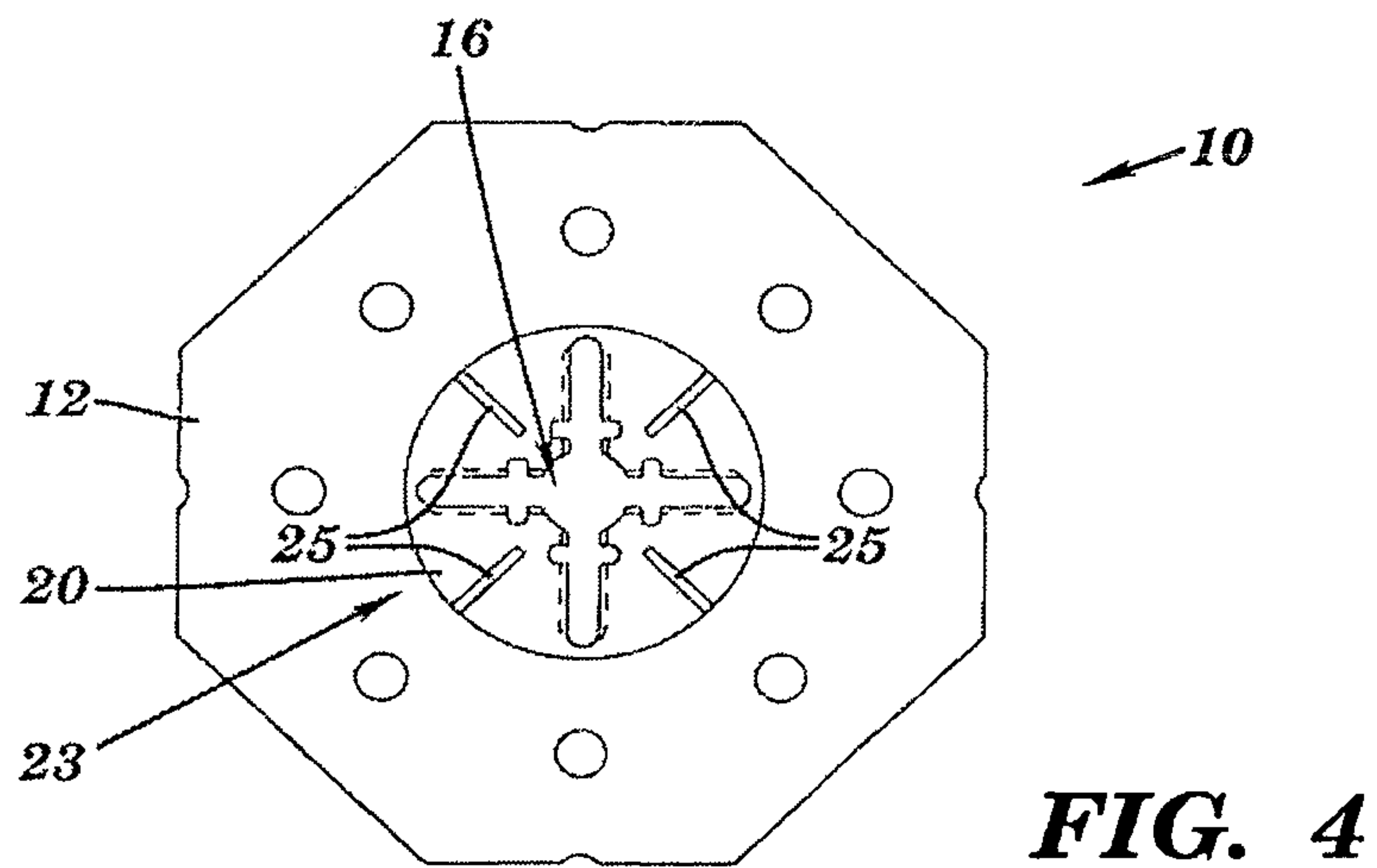
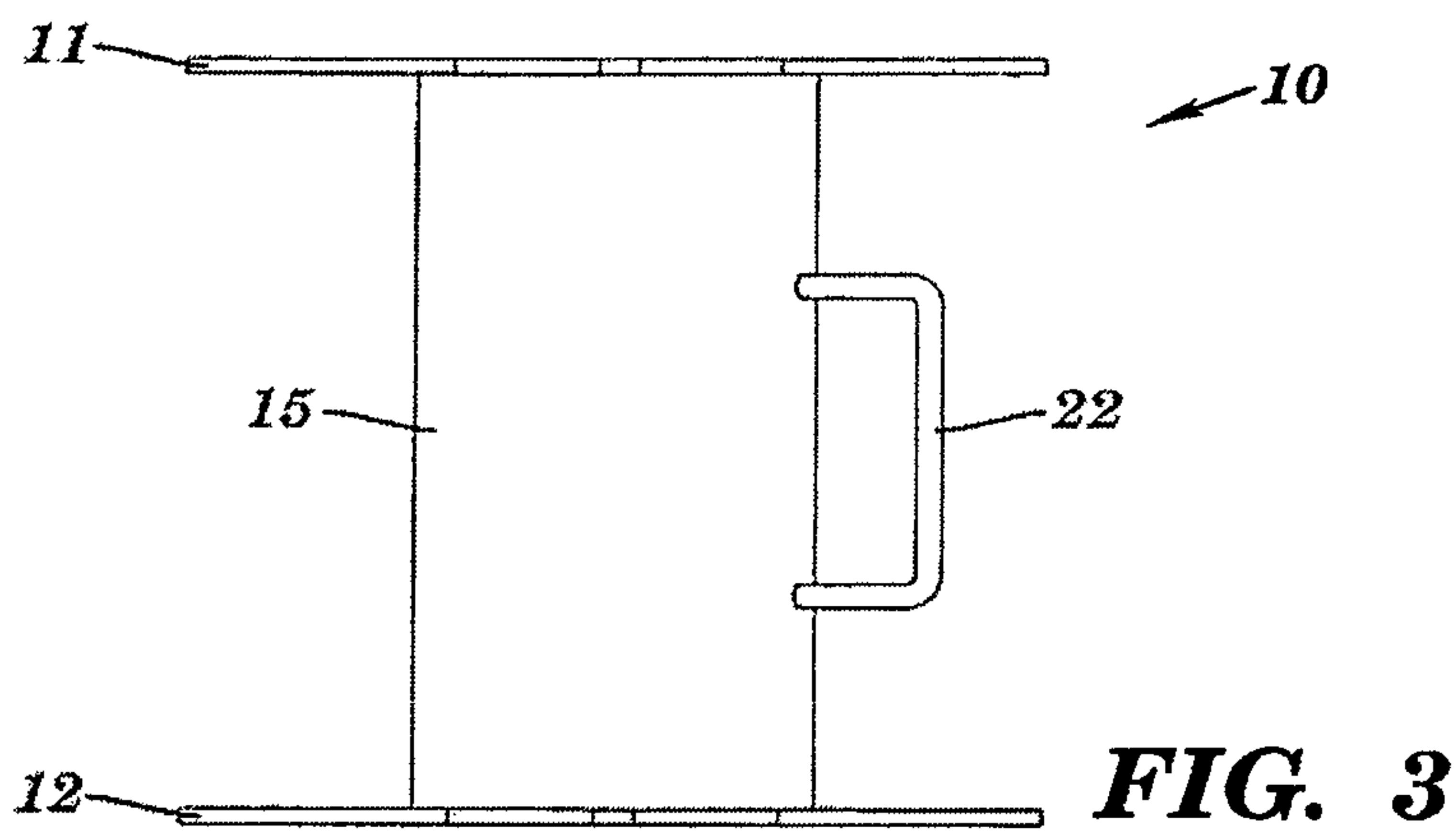
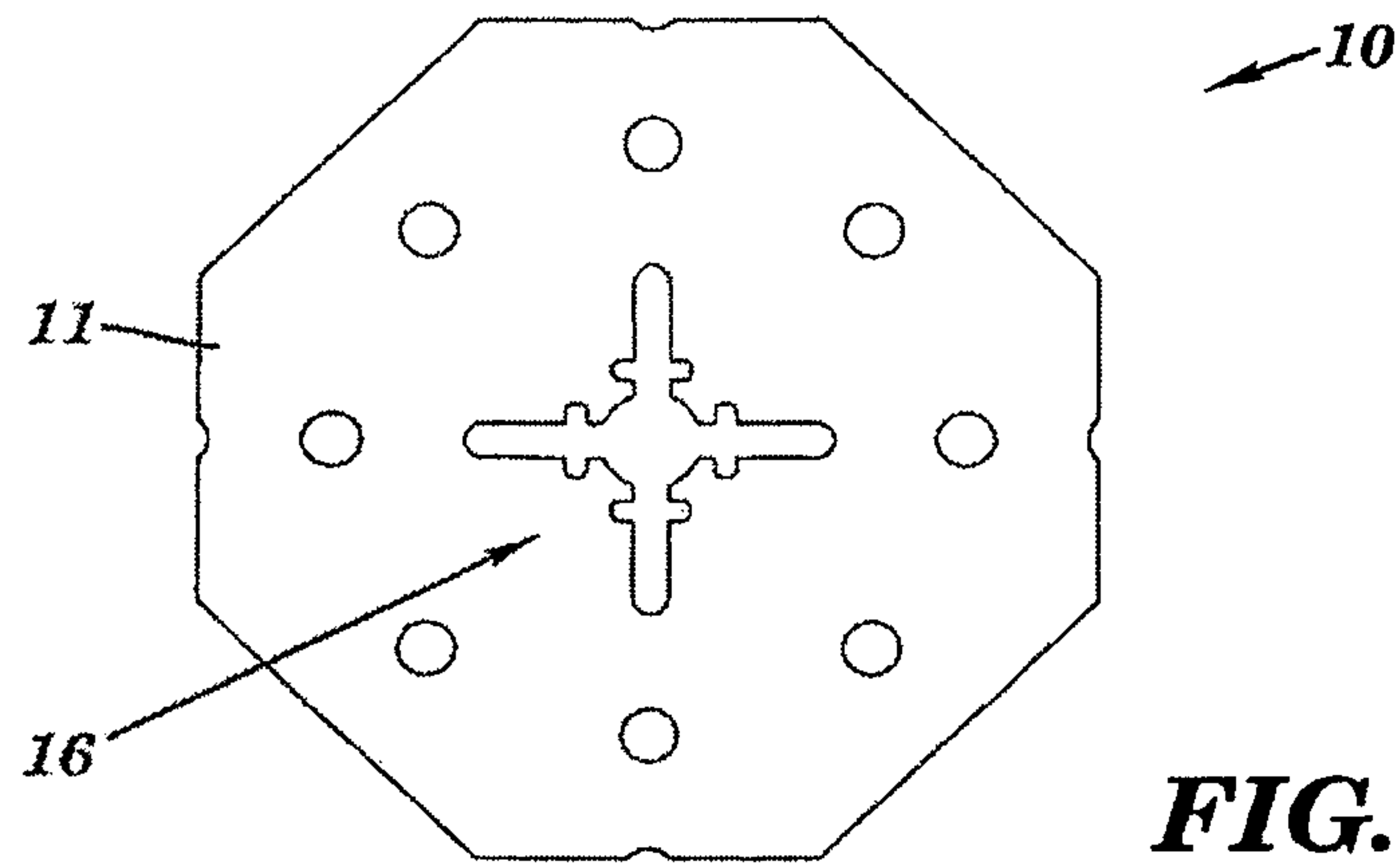

FIG. 1



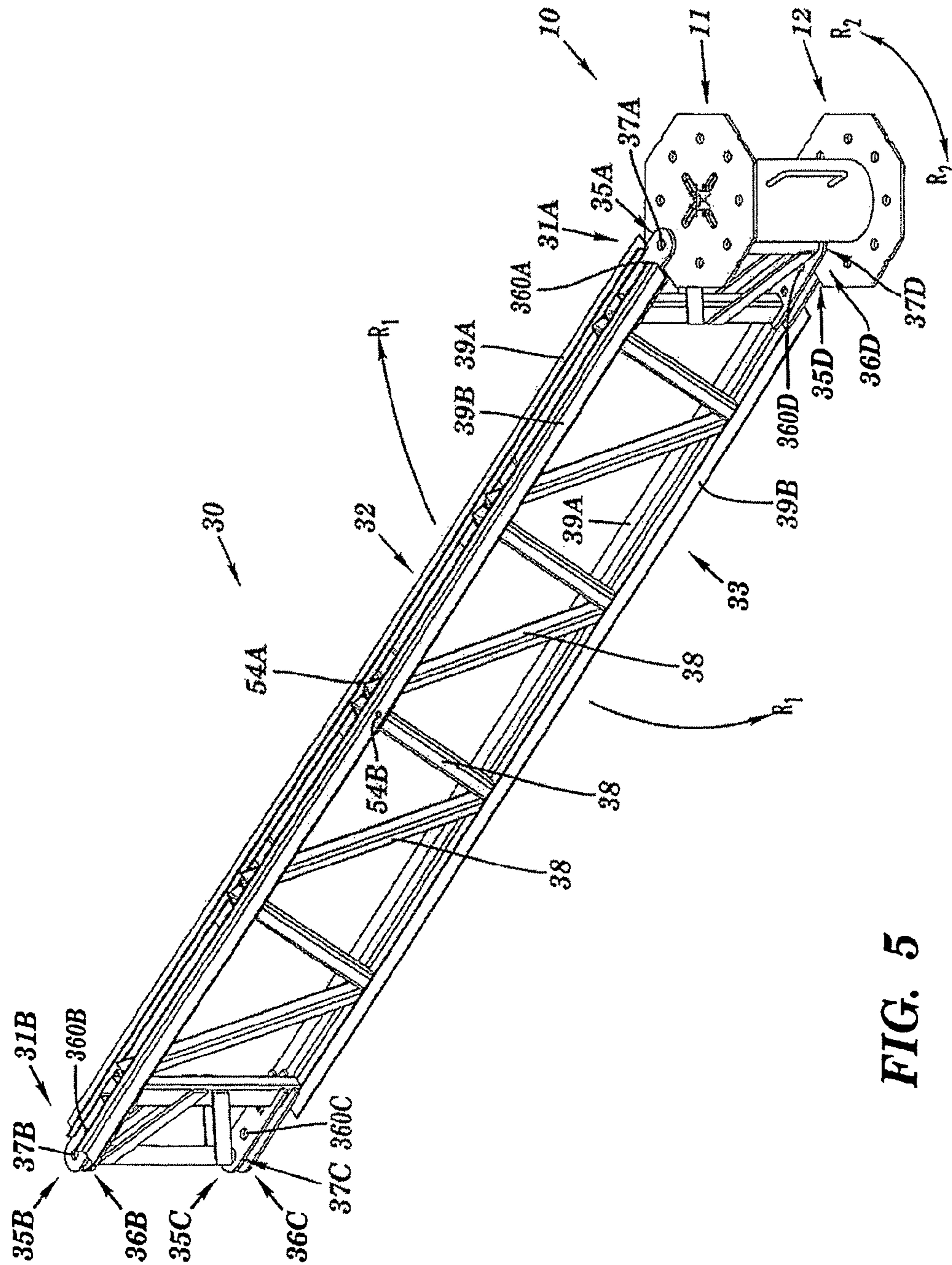

FIG. 5

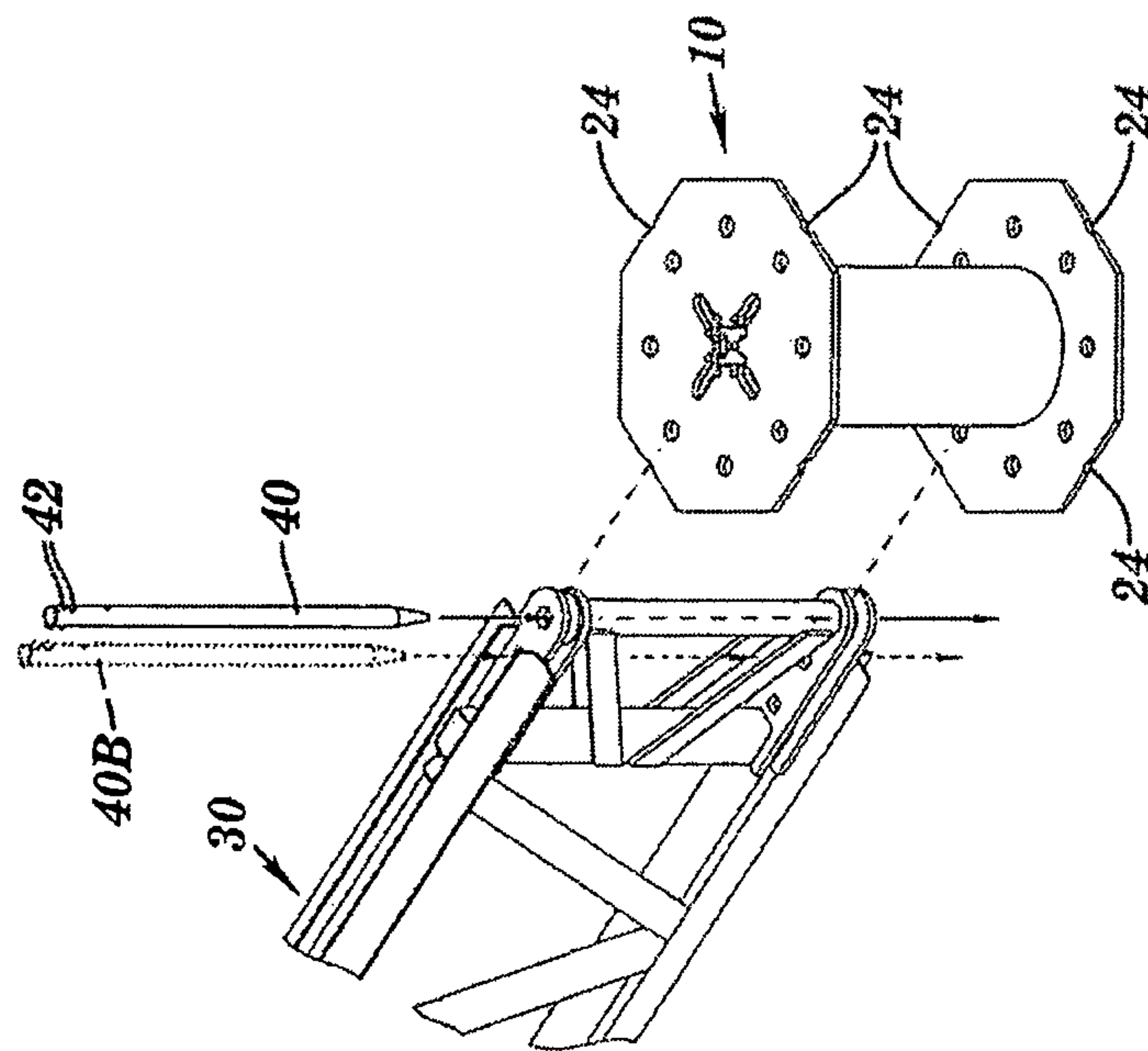

FIG. 6A

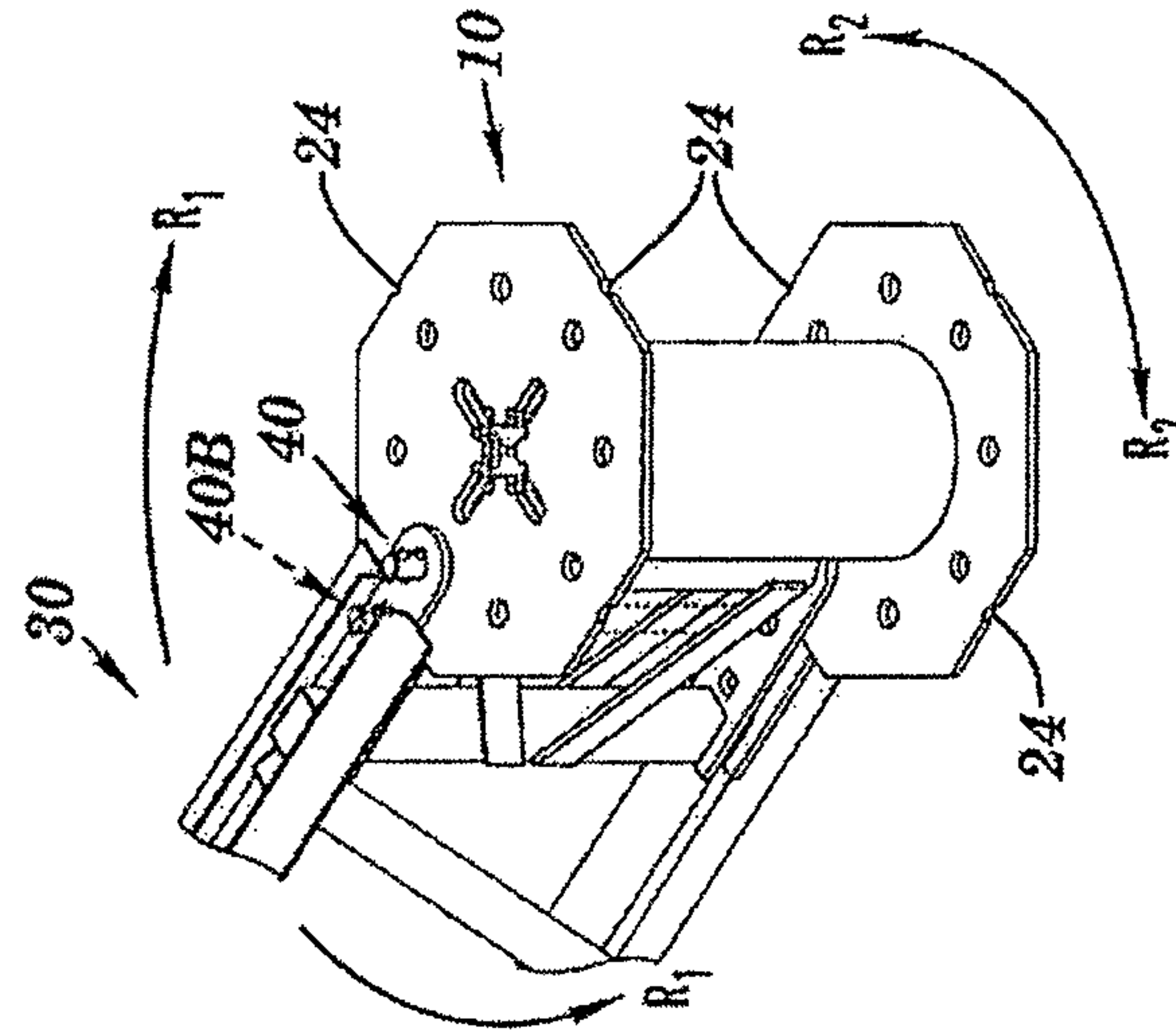

FIG. 6B

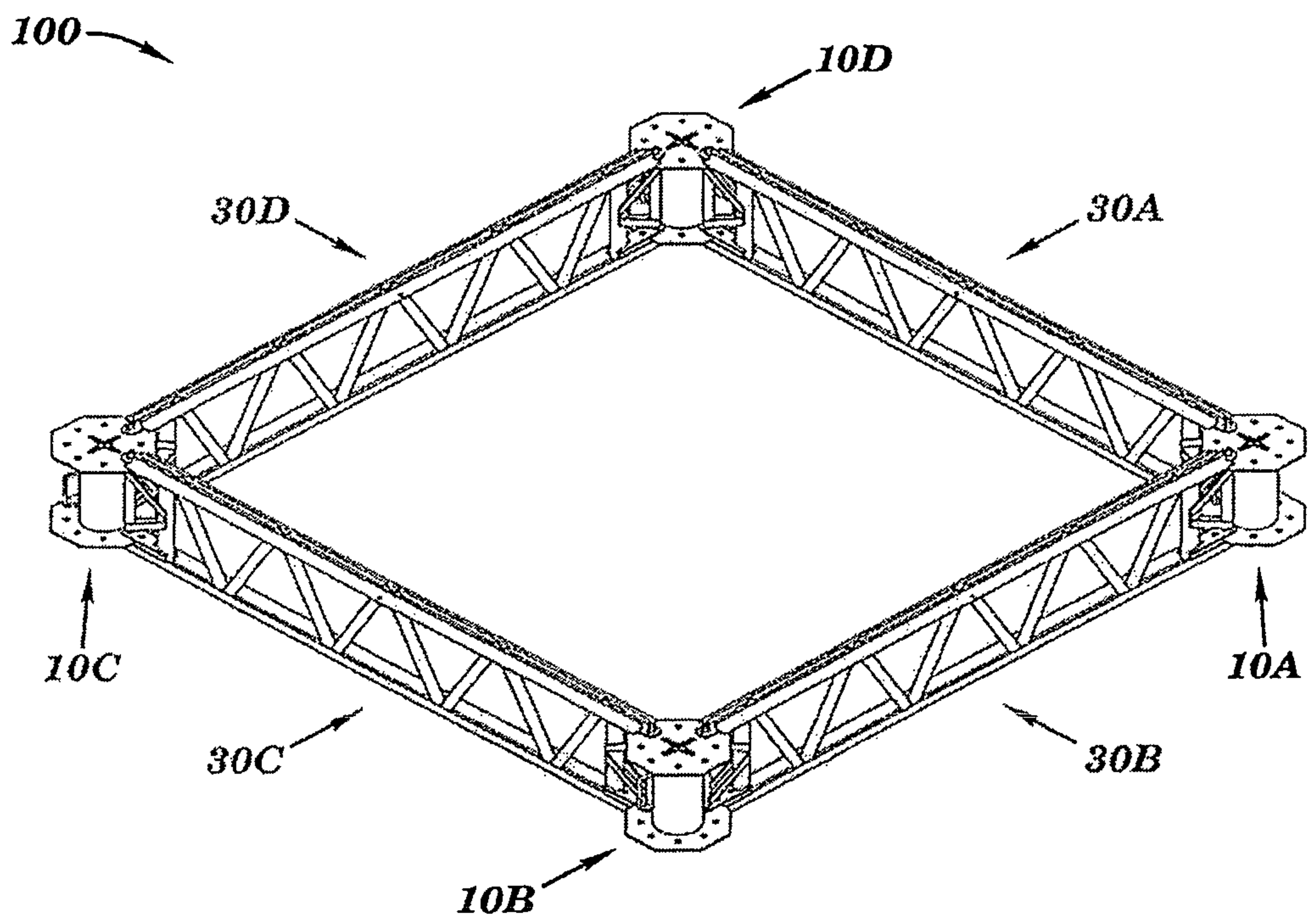

FIG. 7

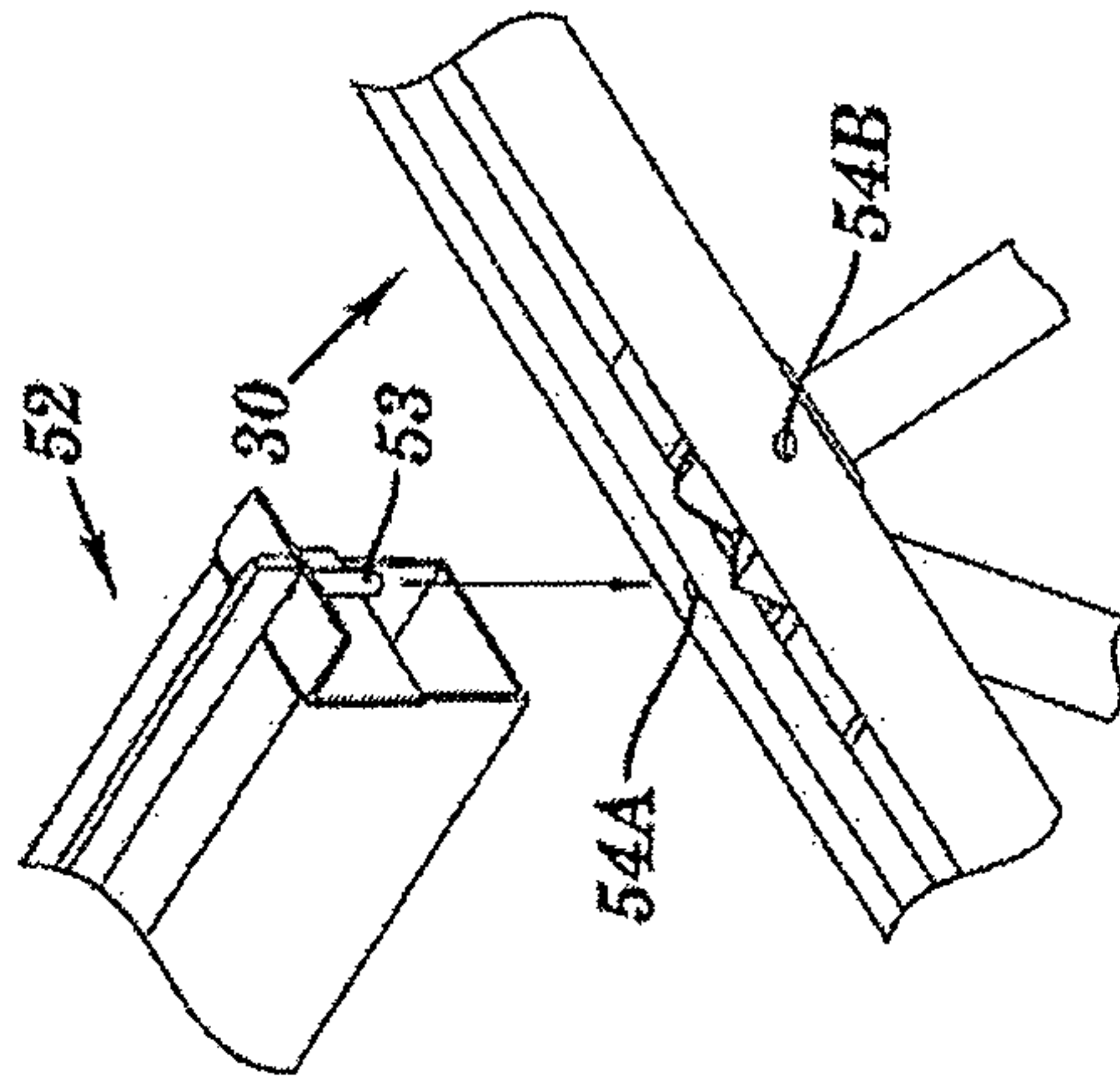

FIG. 8B

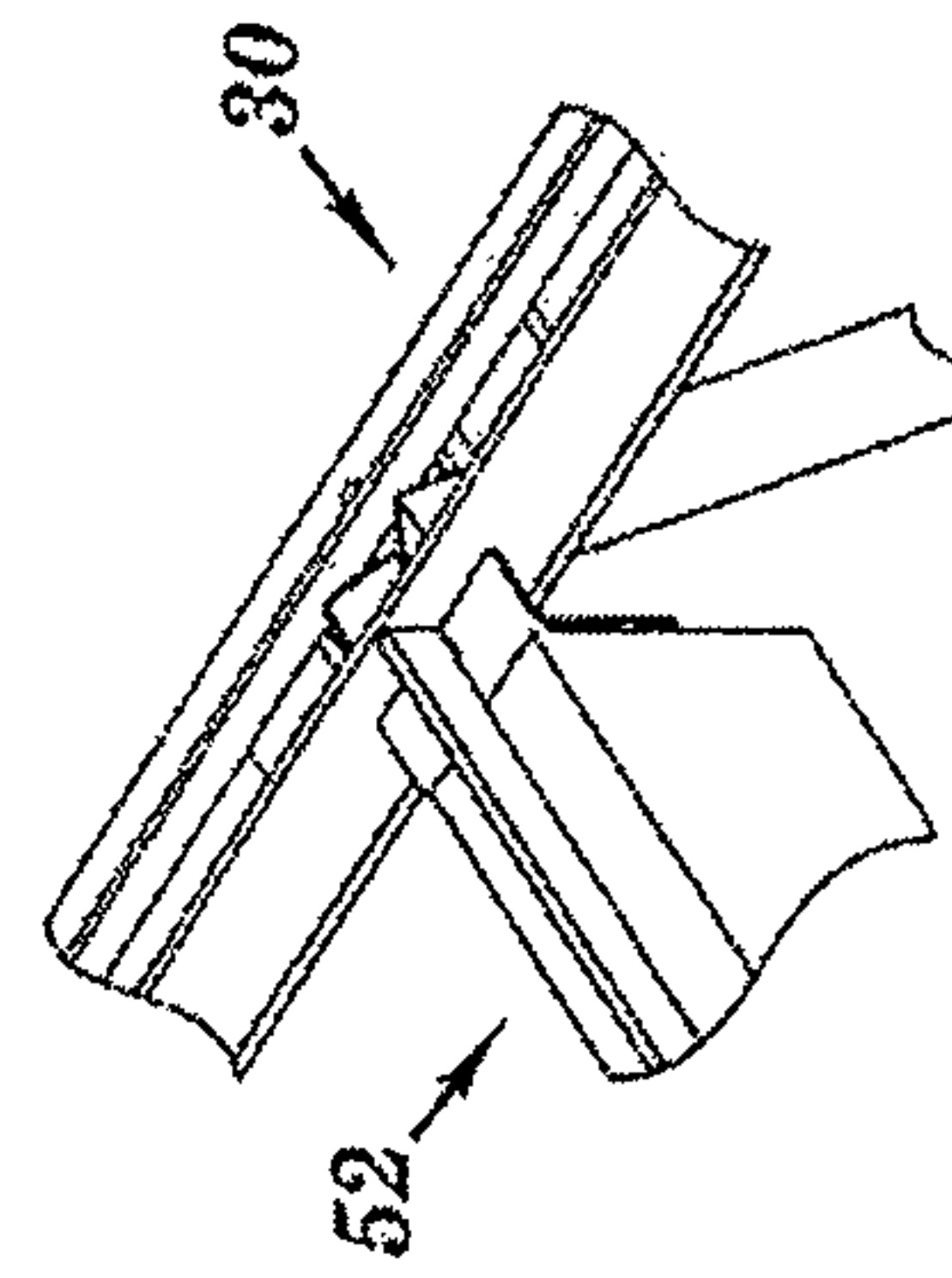

FIG. 8C

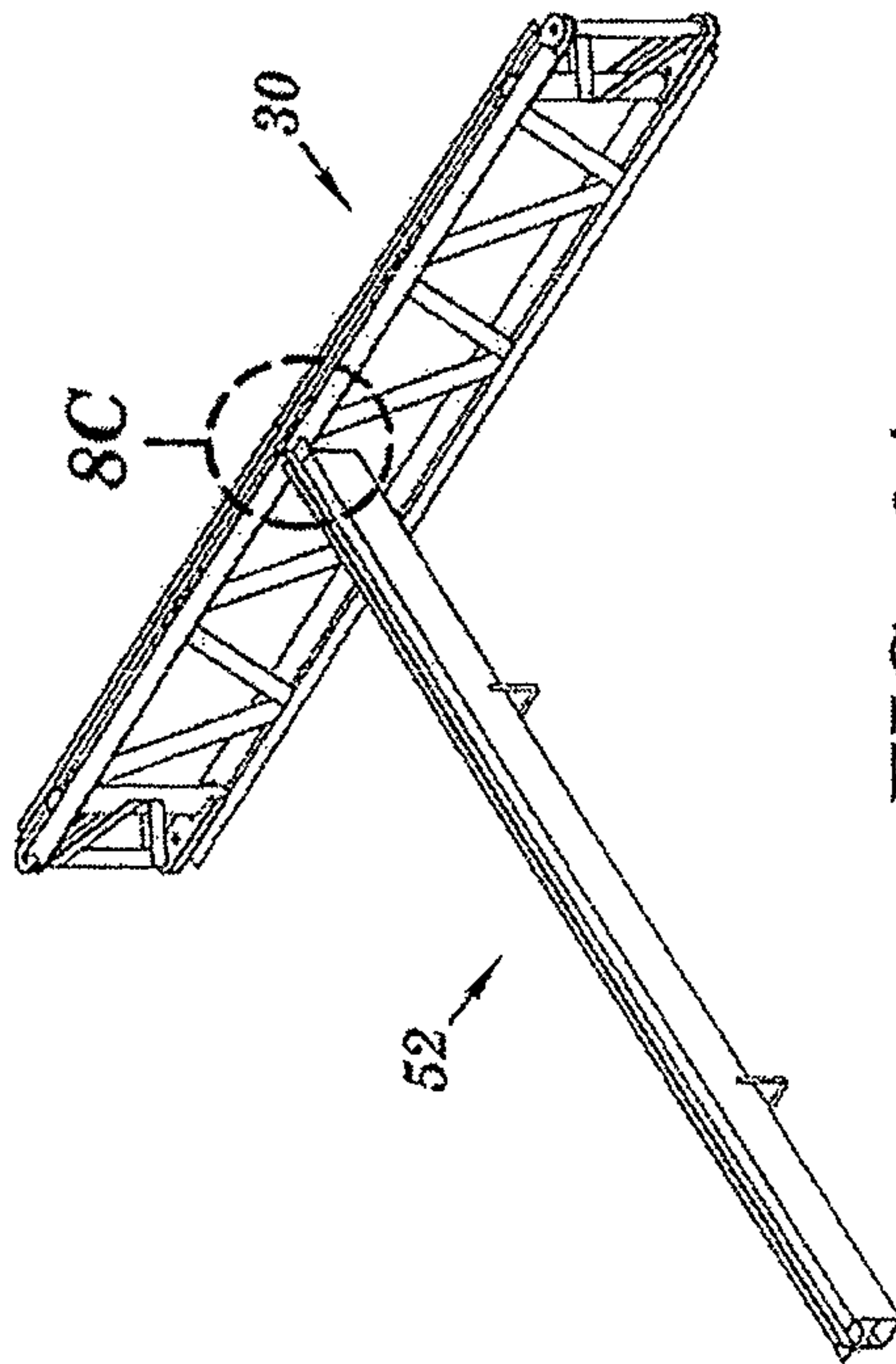

FIG. 8A

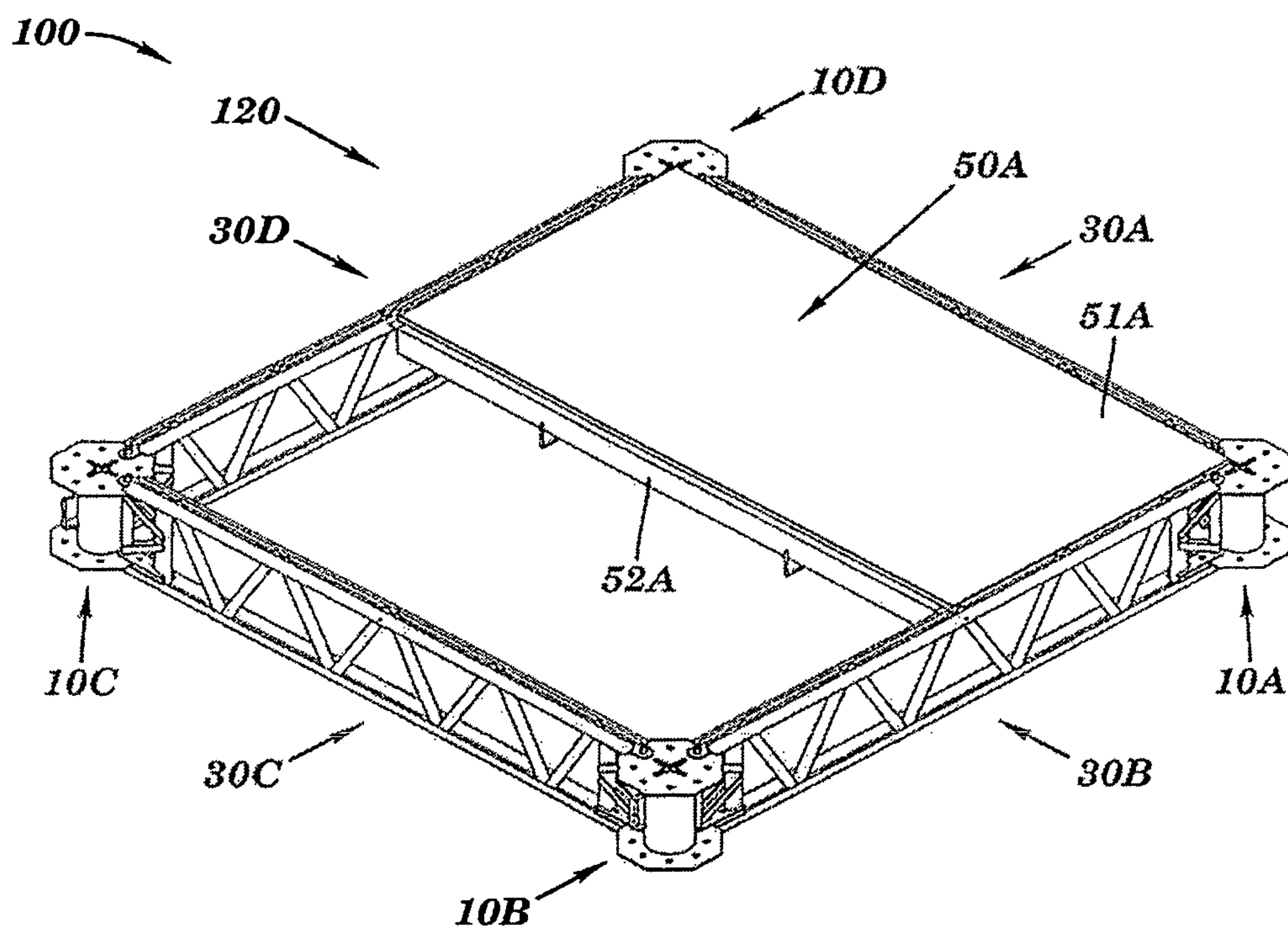

FIG. 9

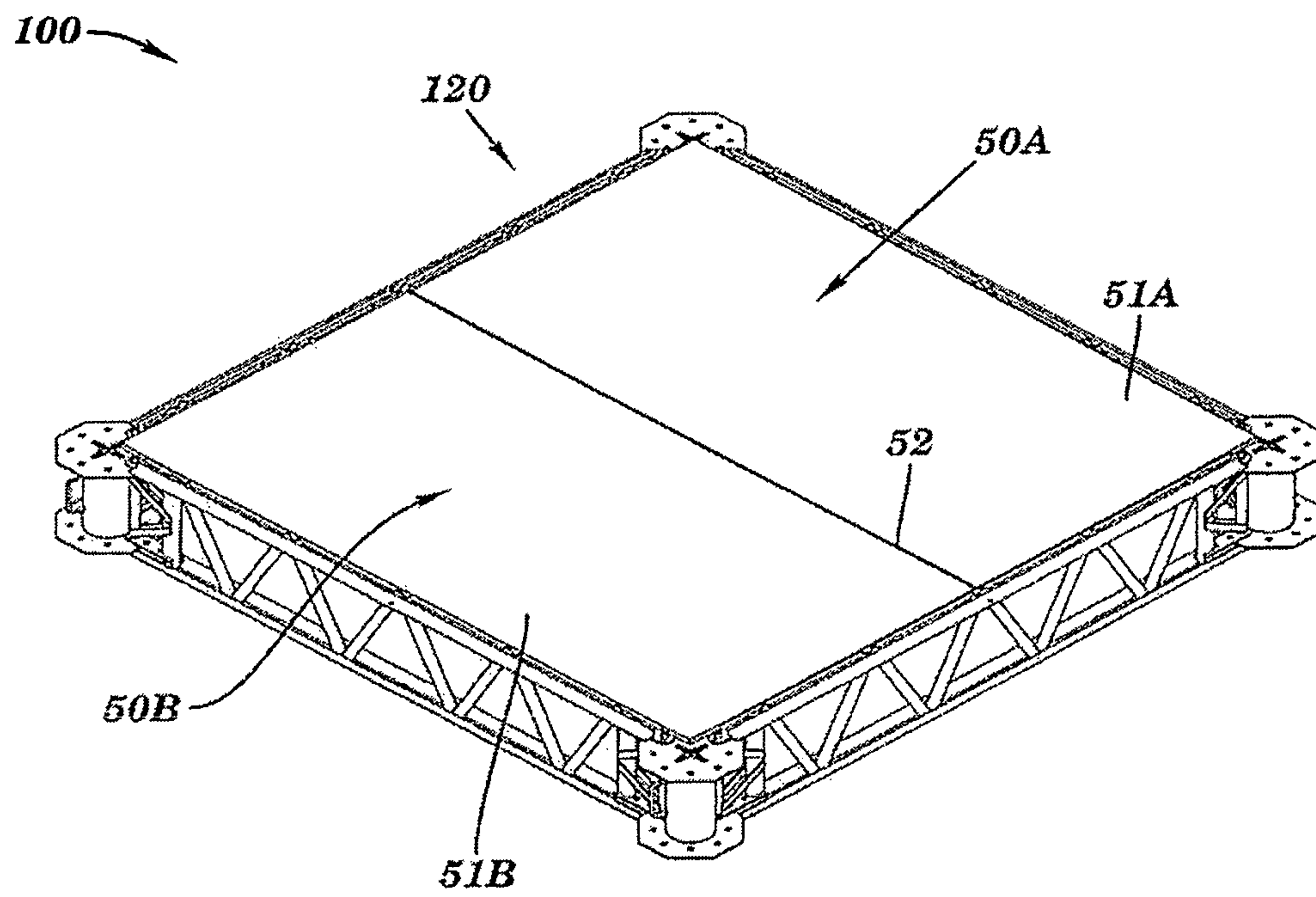

FIG. 10

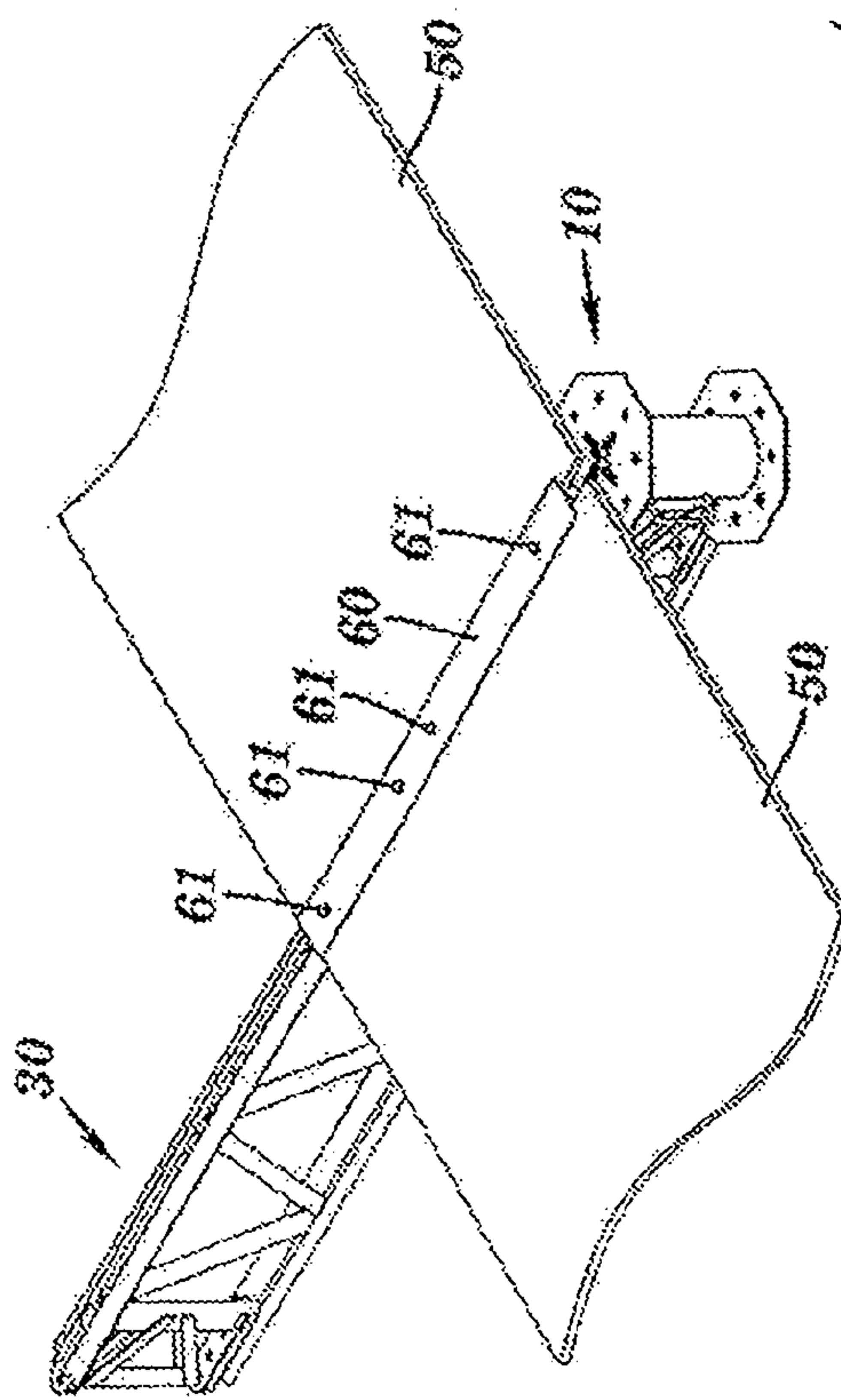

FIG. 11A

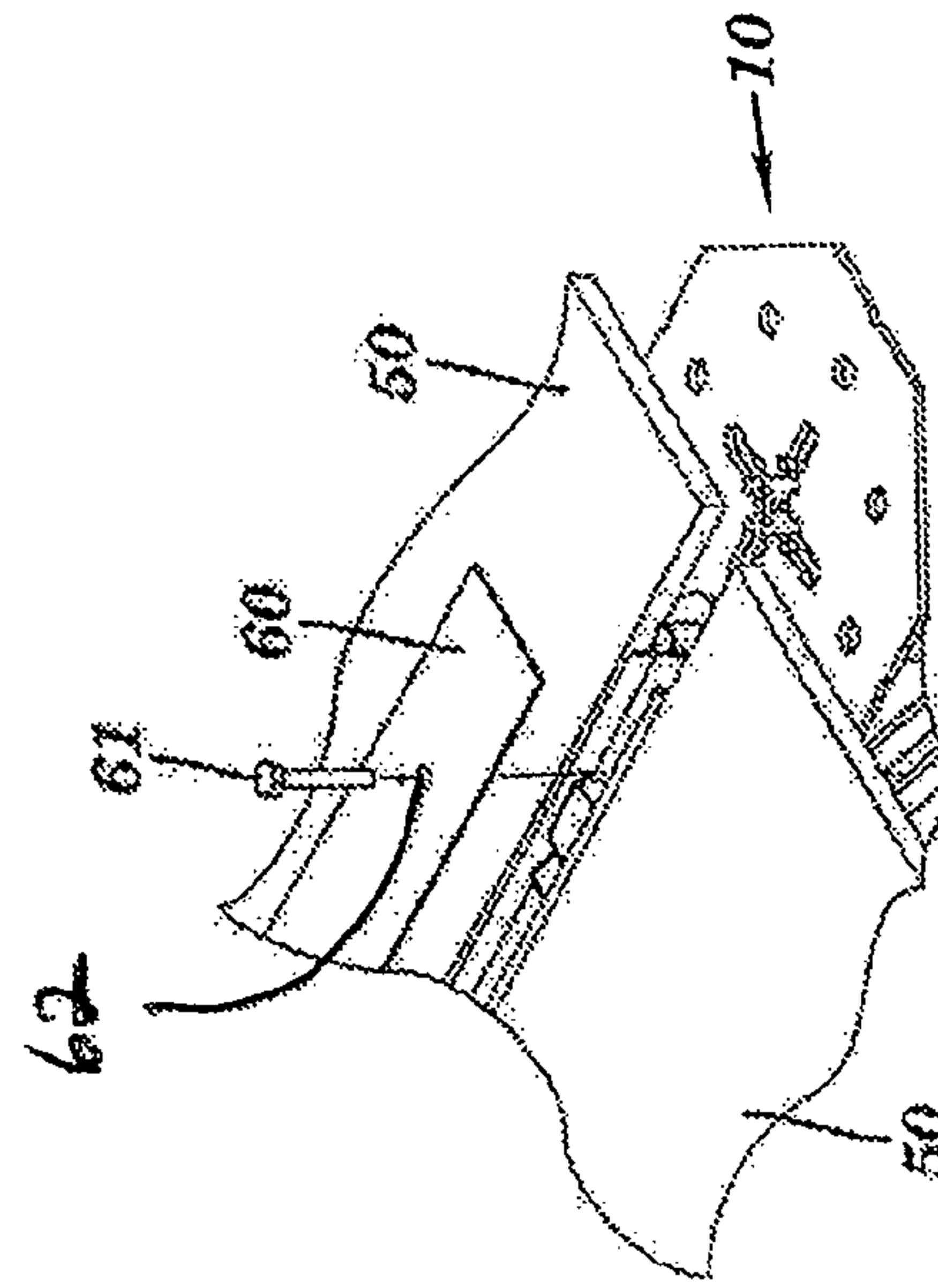

FIG. 11B

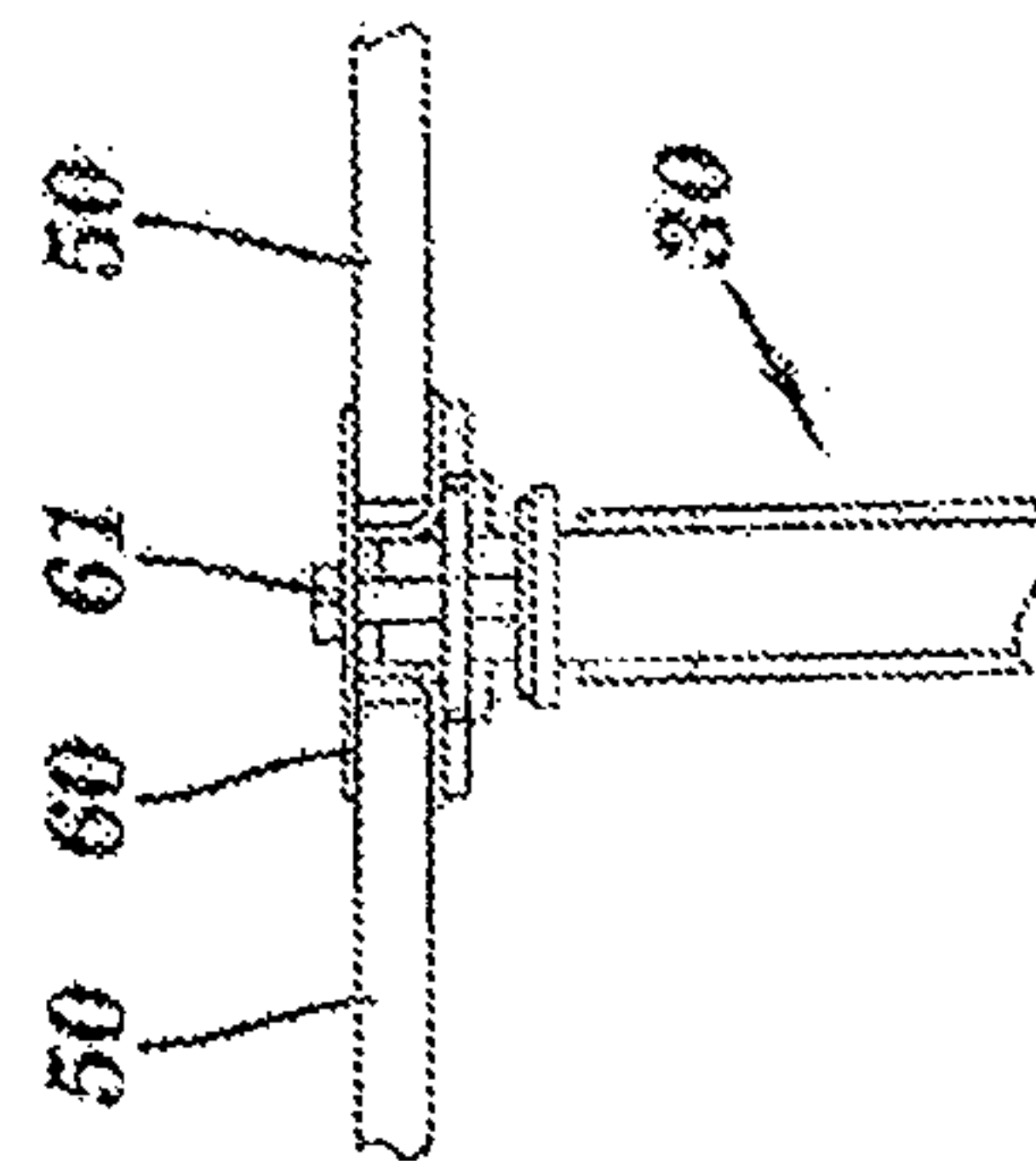

FIG. 11C

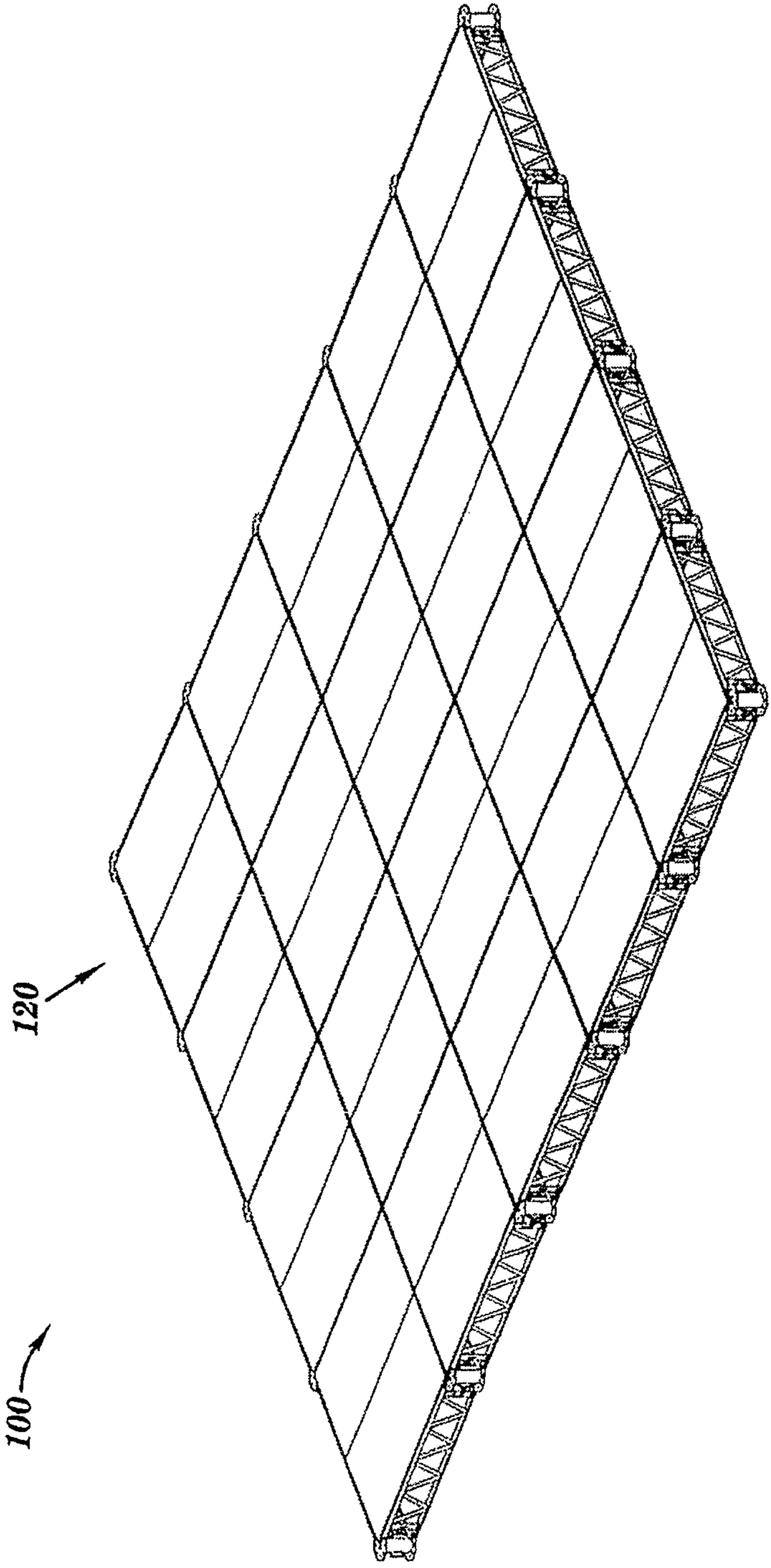

FIG. 12

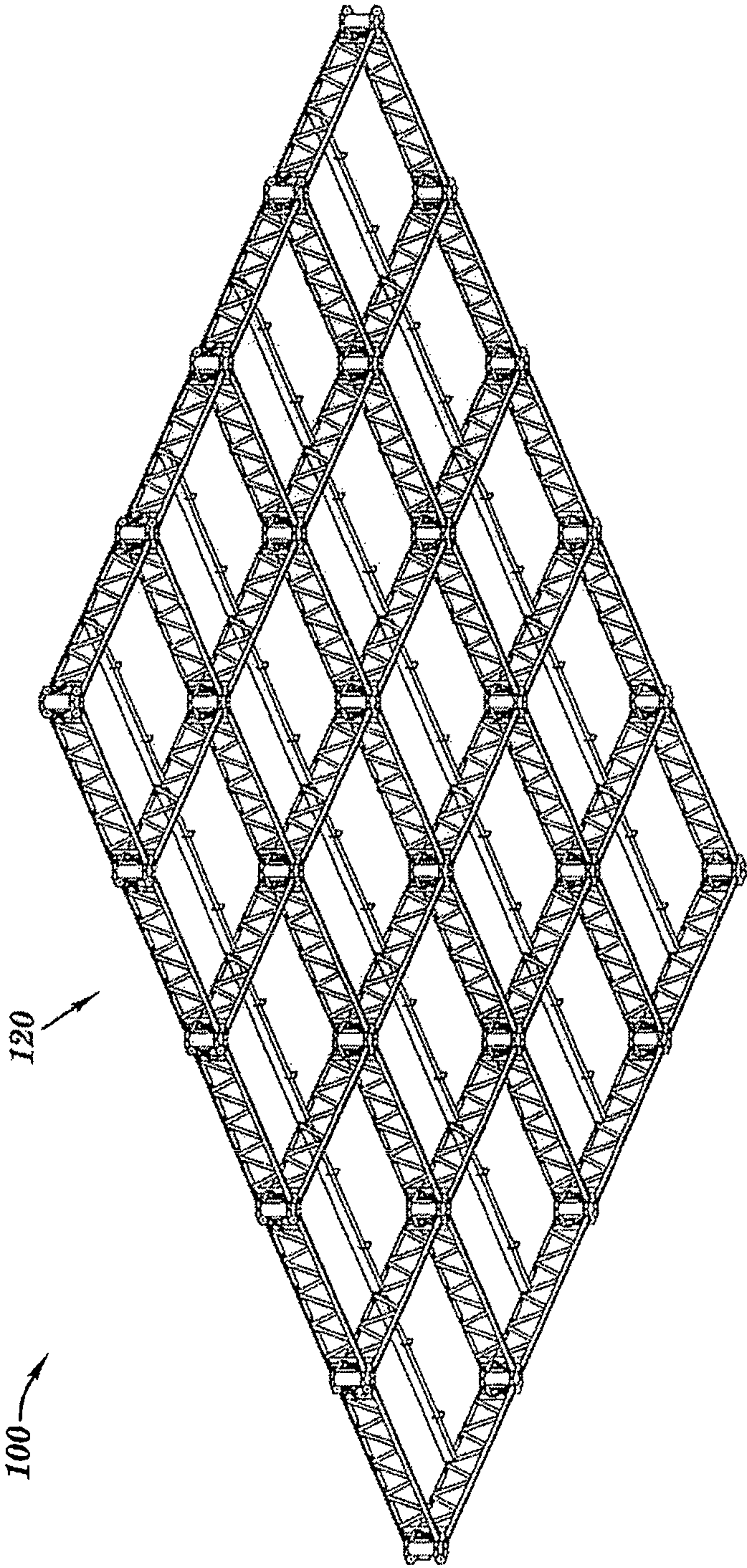

FIG. 13

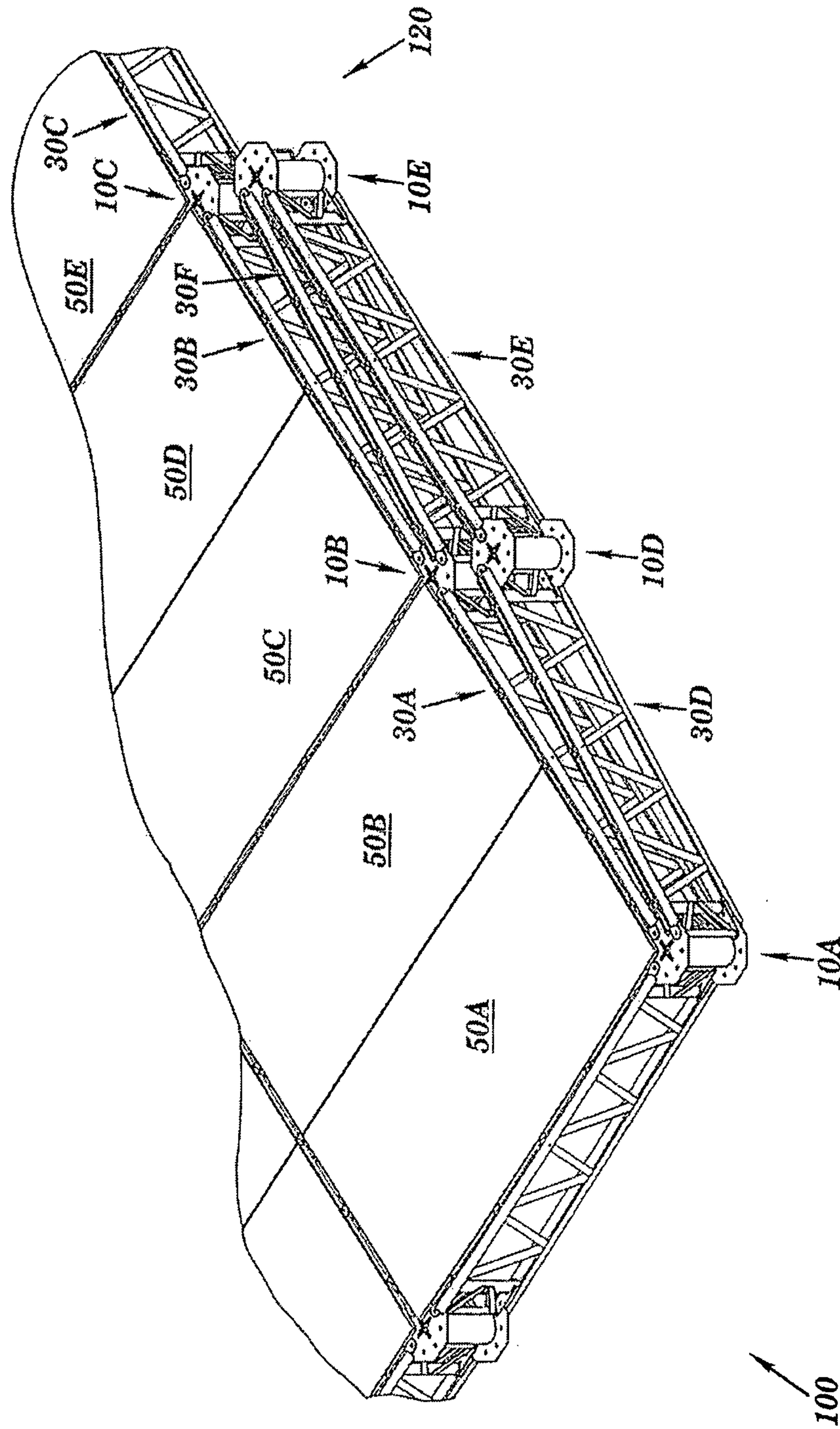

FIG. 14

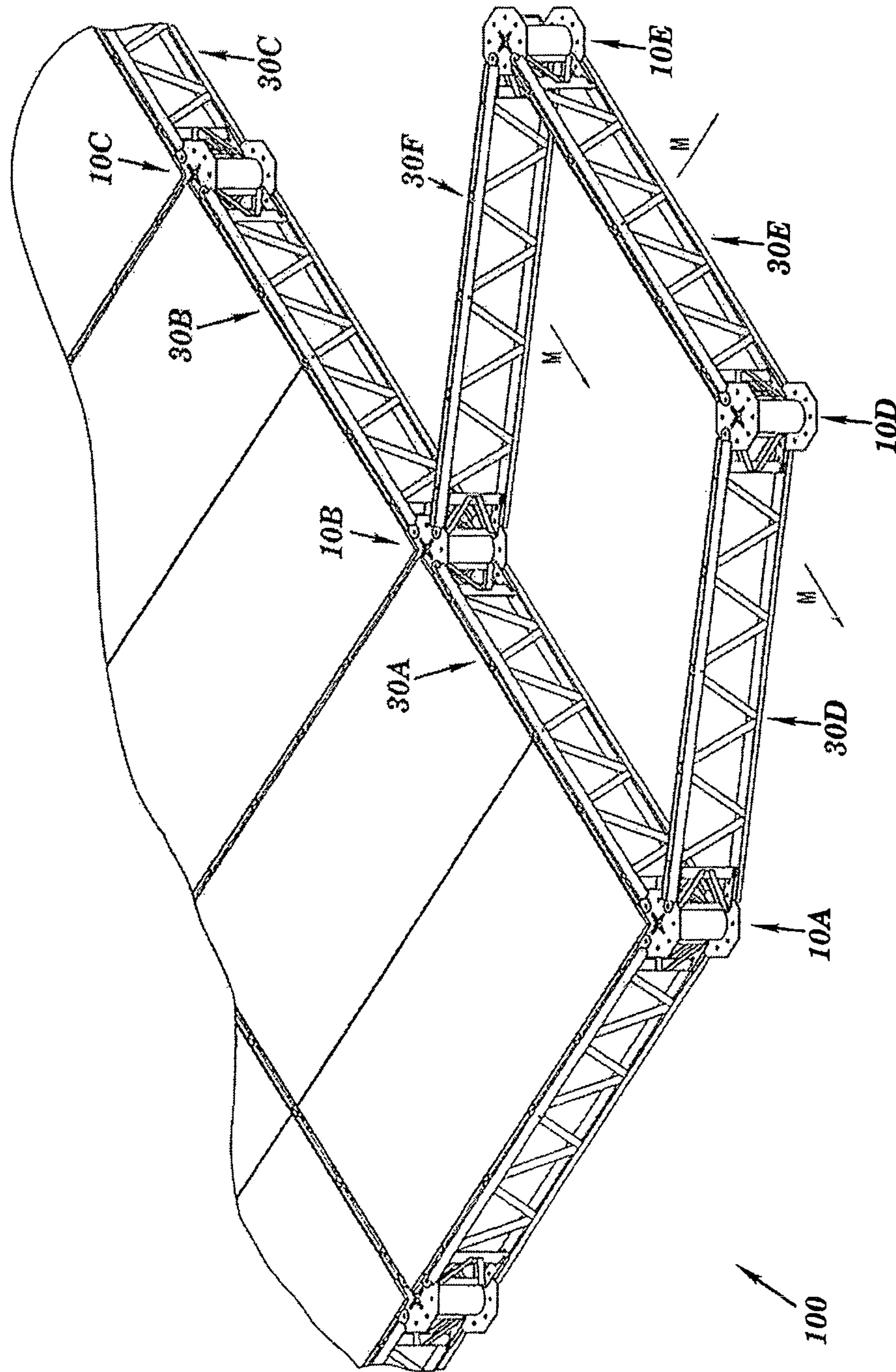

FIG. 16

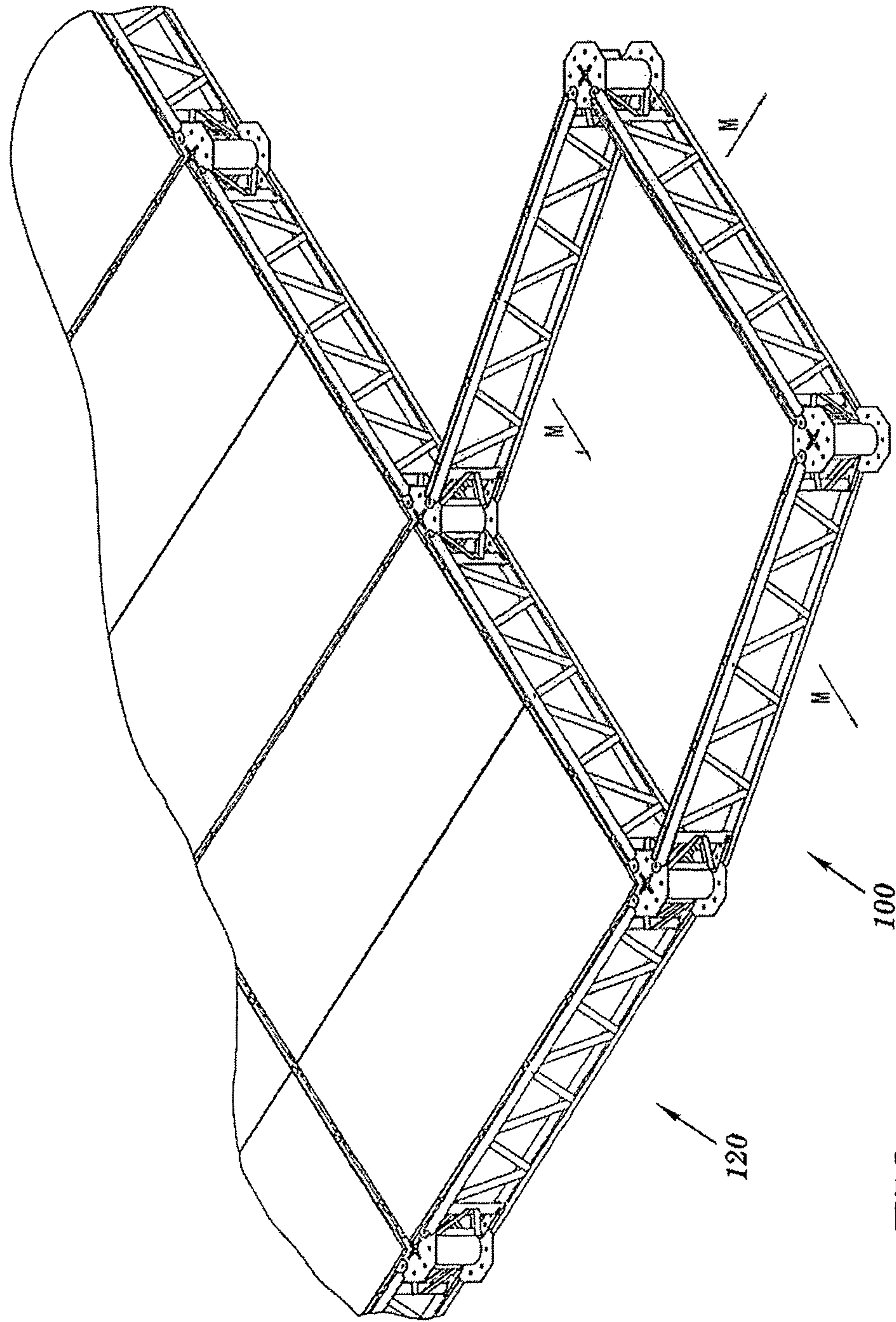

FIG. 17

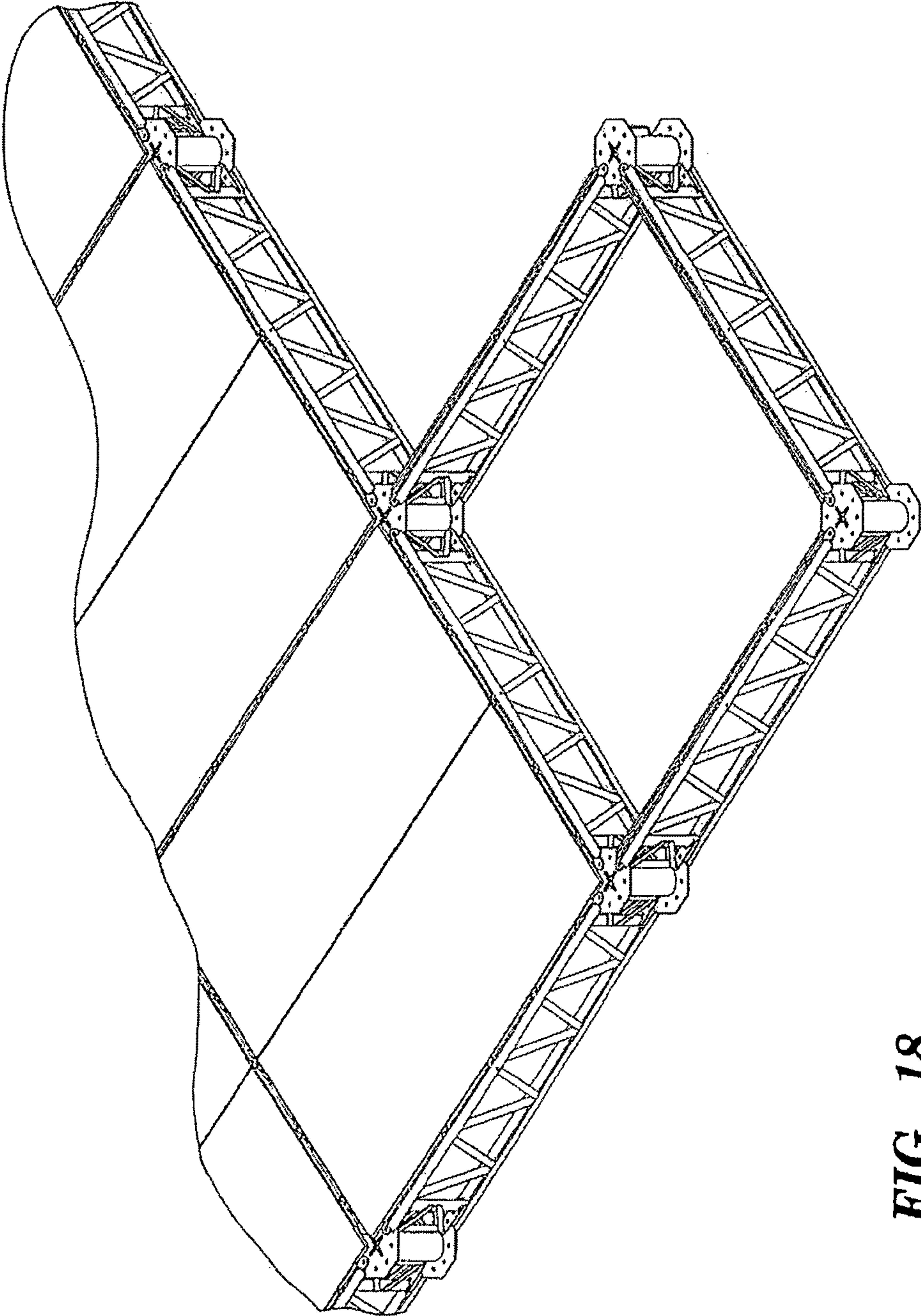
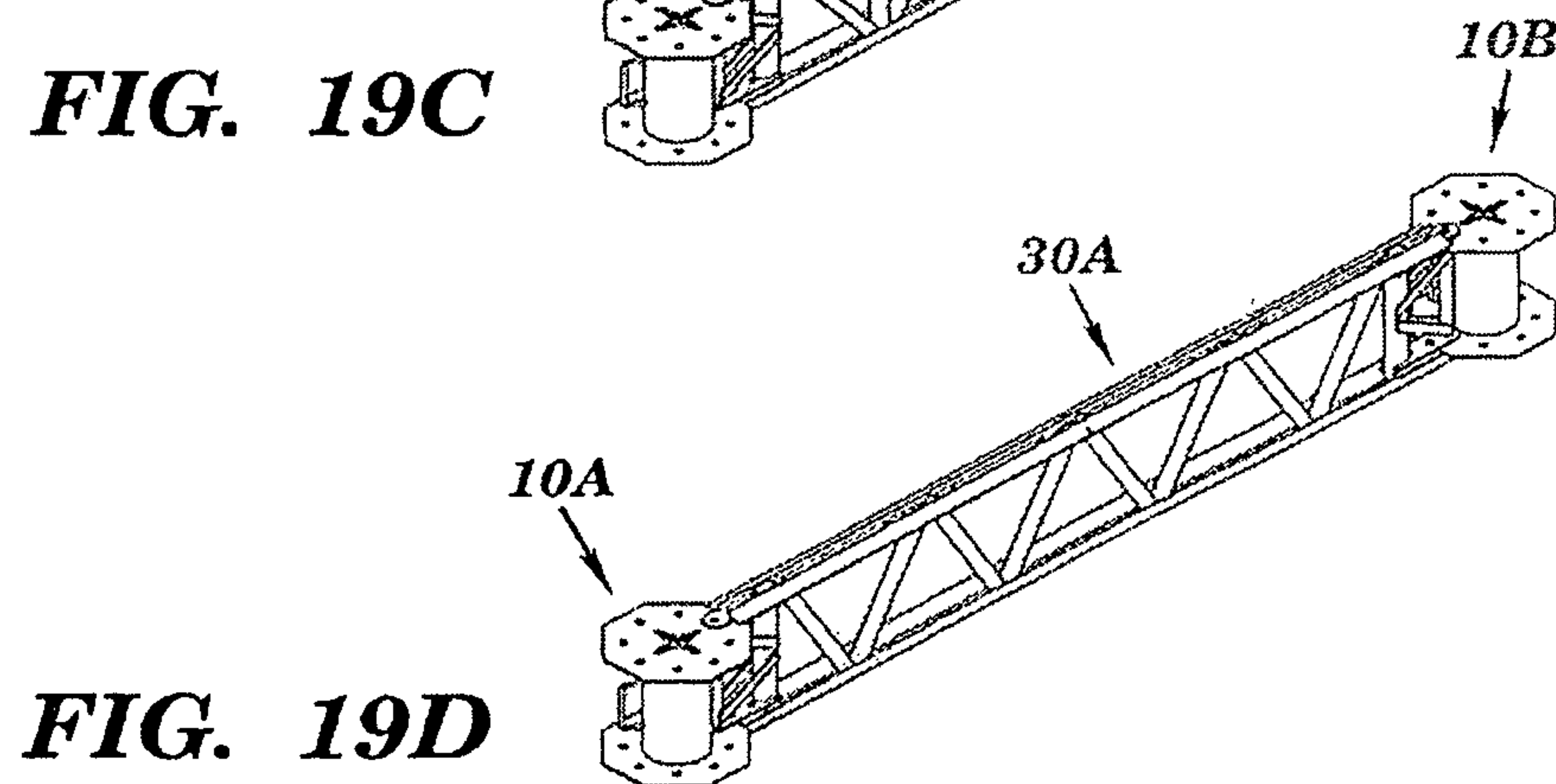
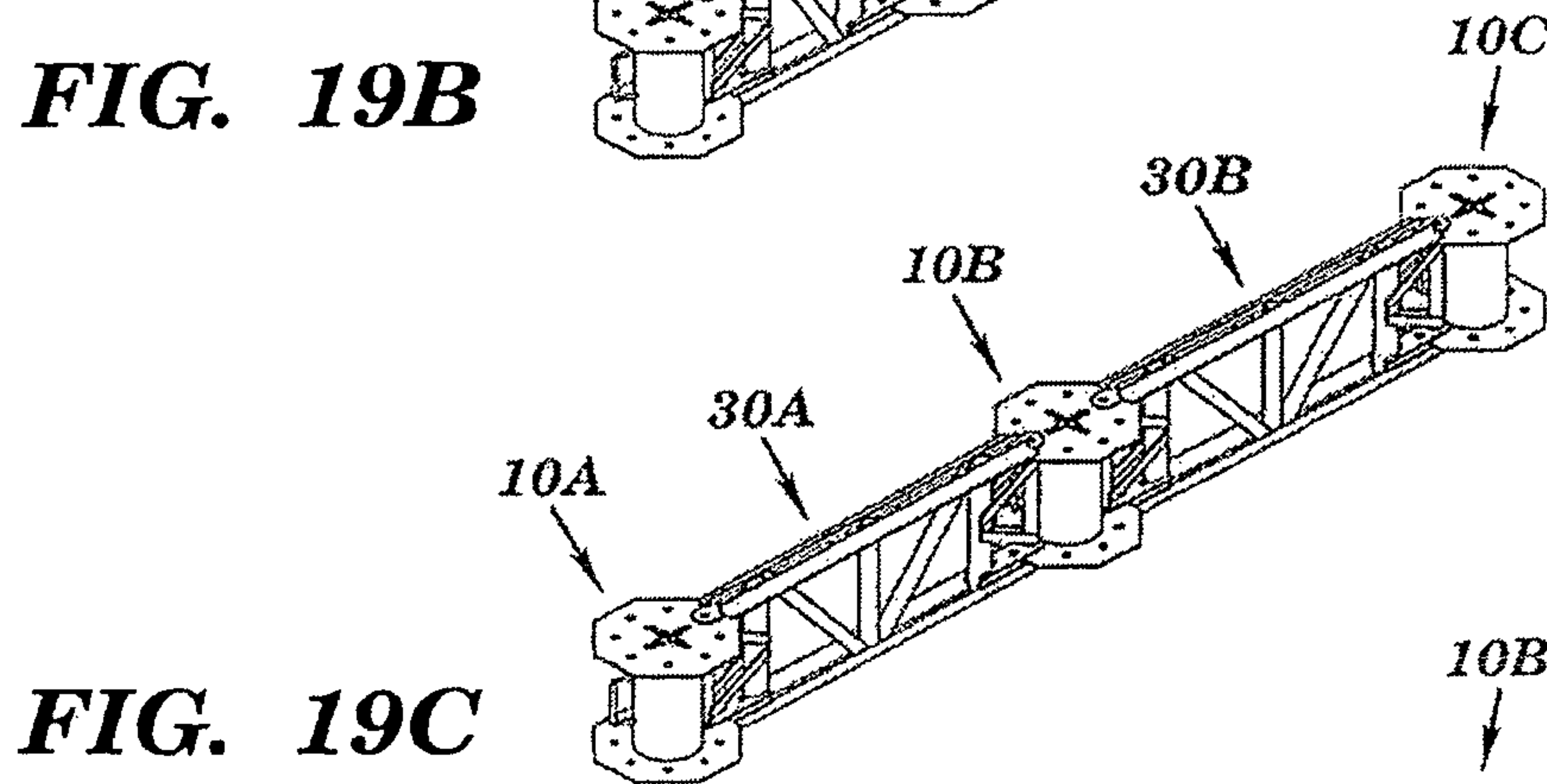
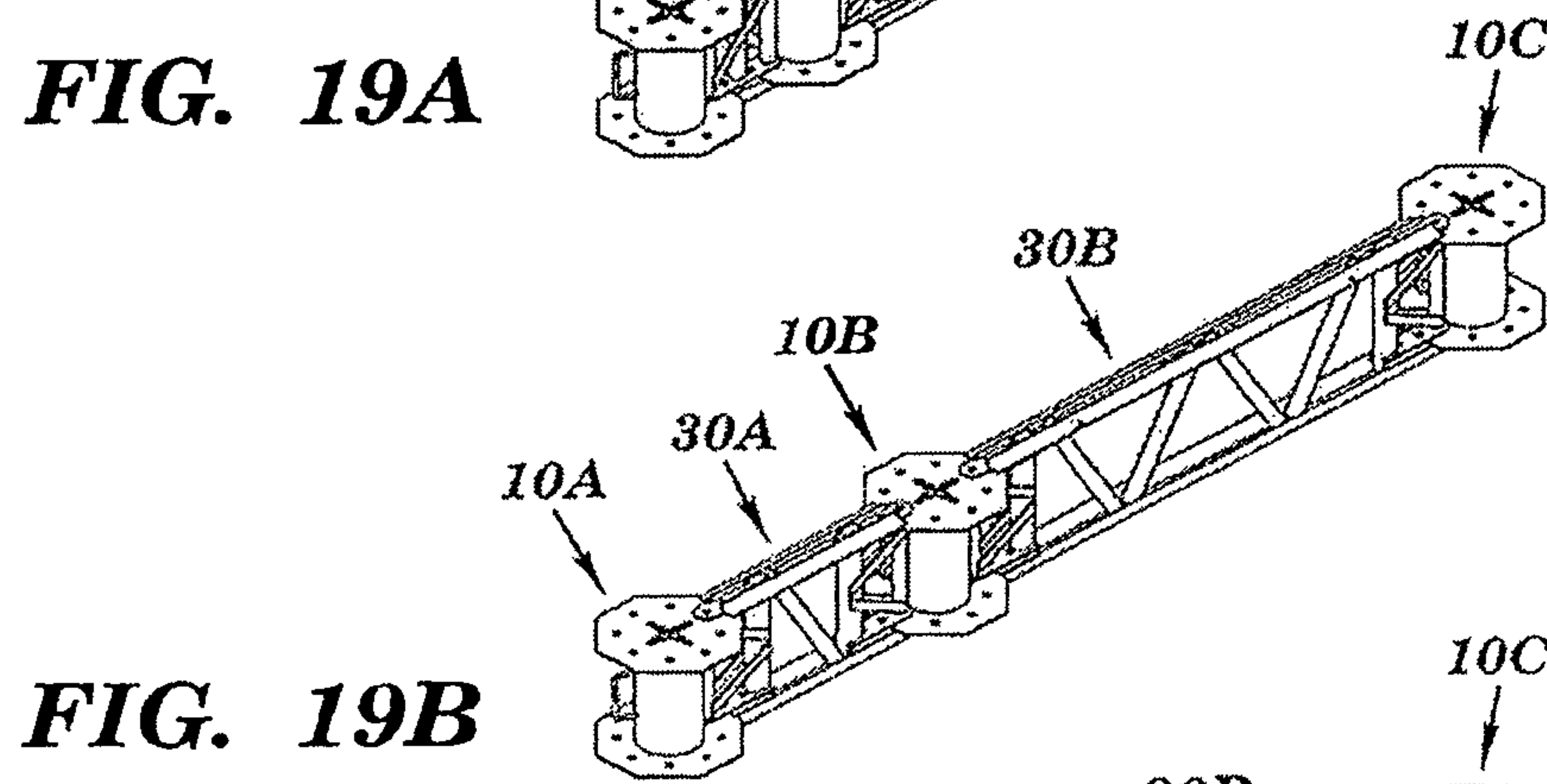
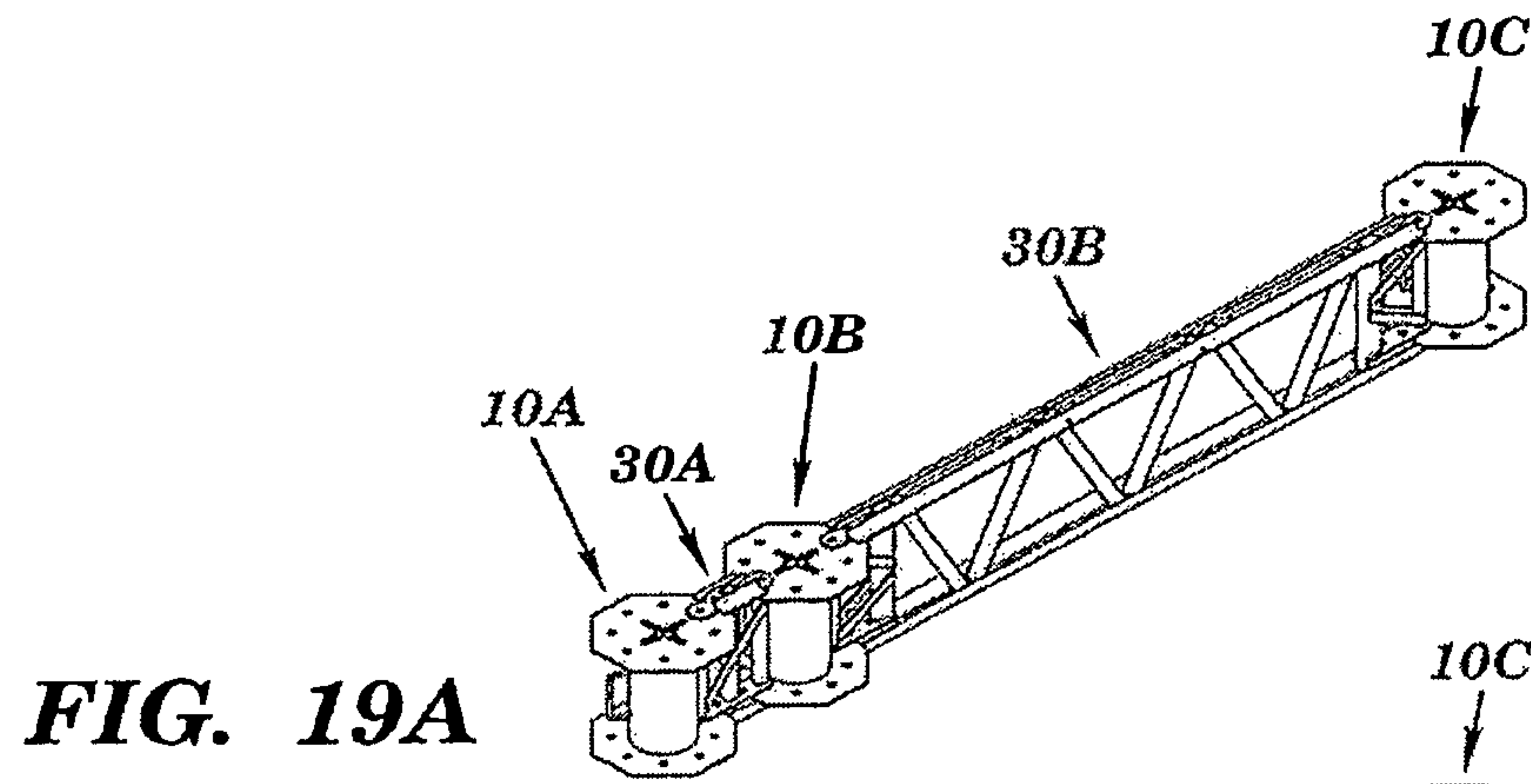

FIG. 18



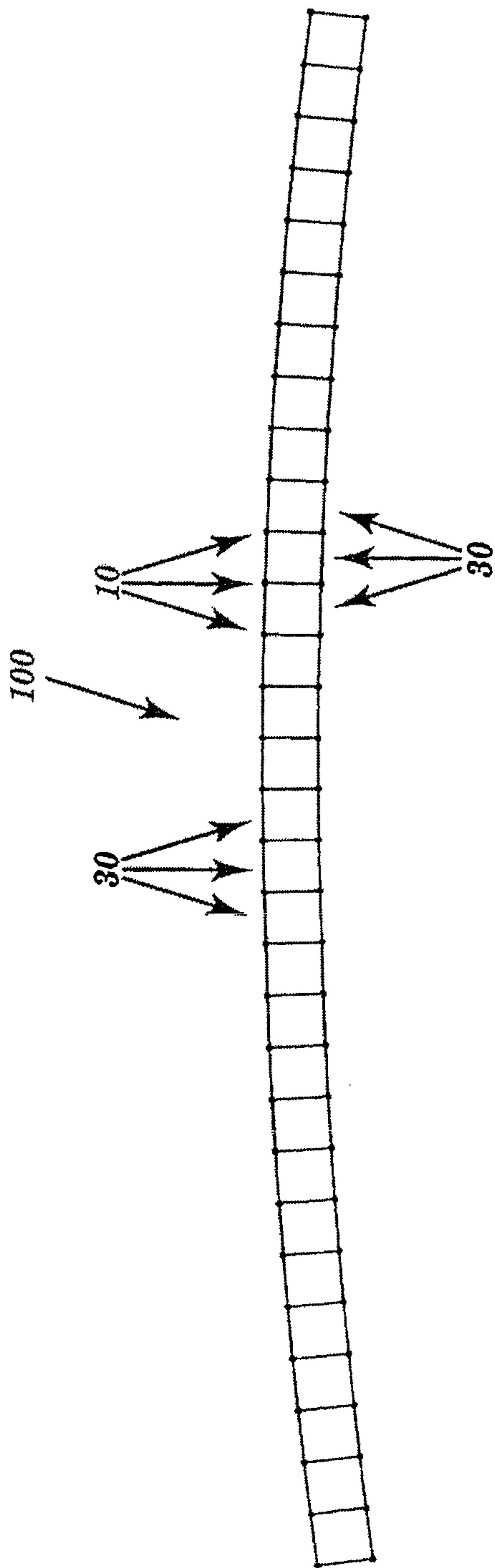

FIG. 20A

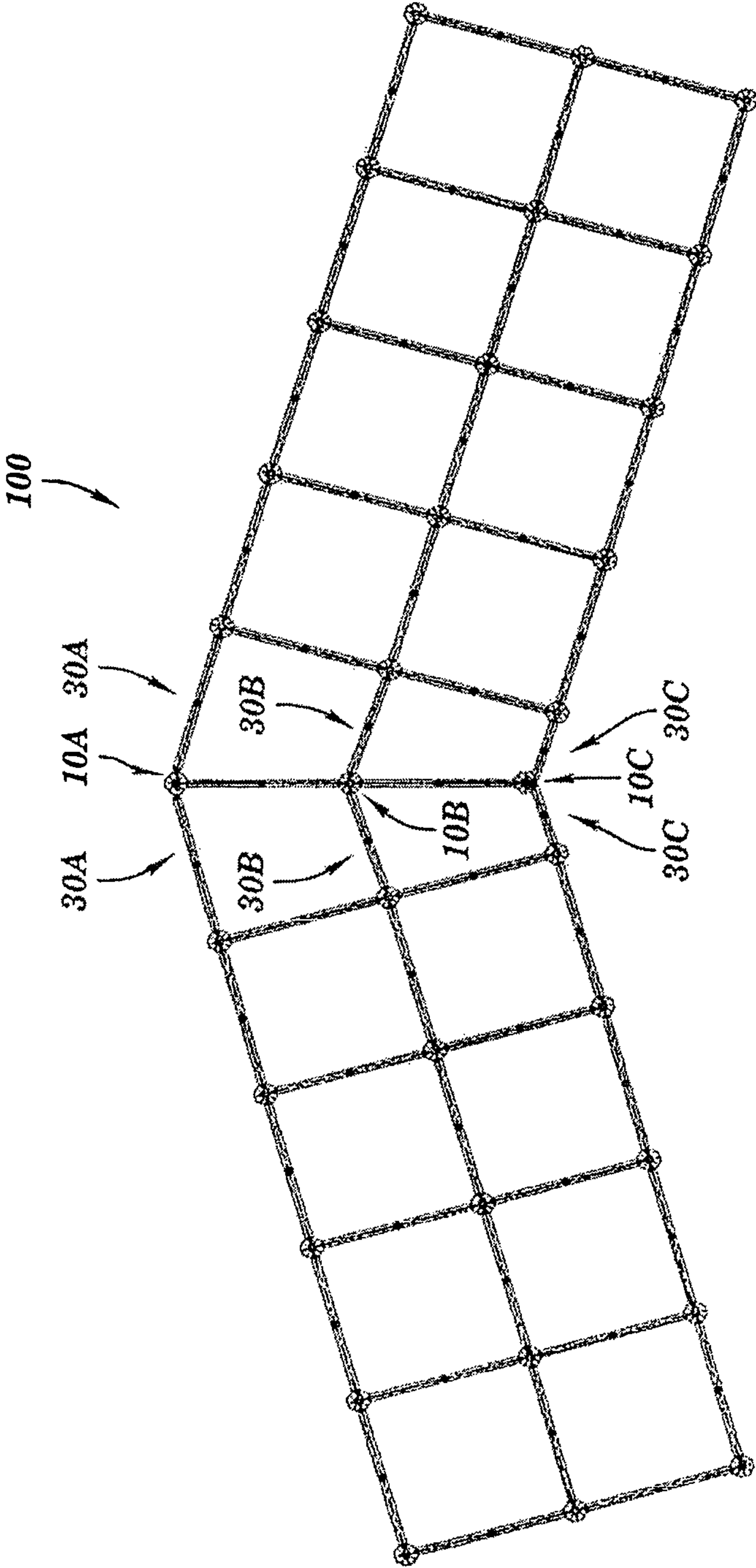
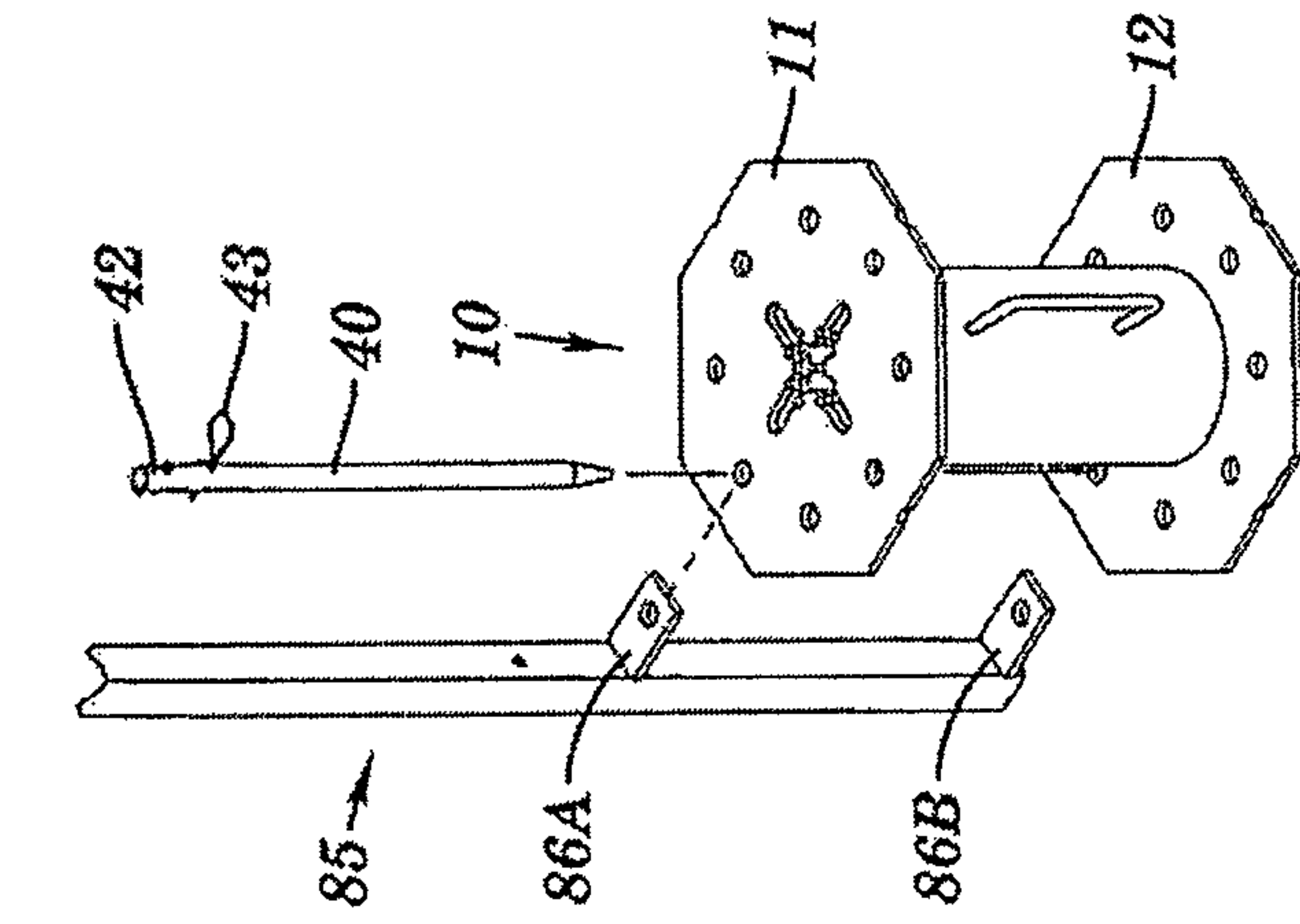
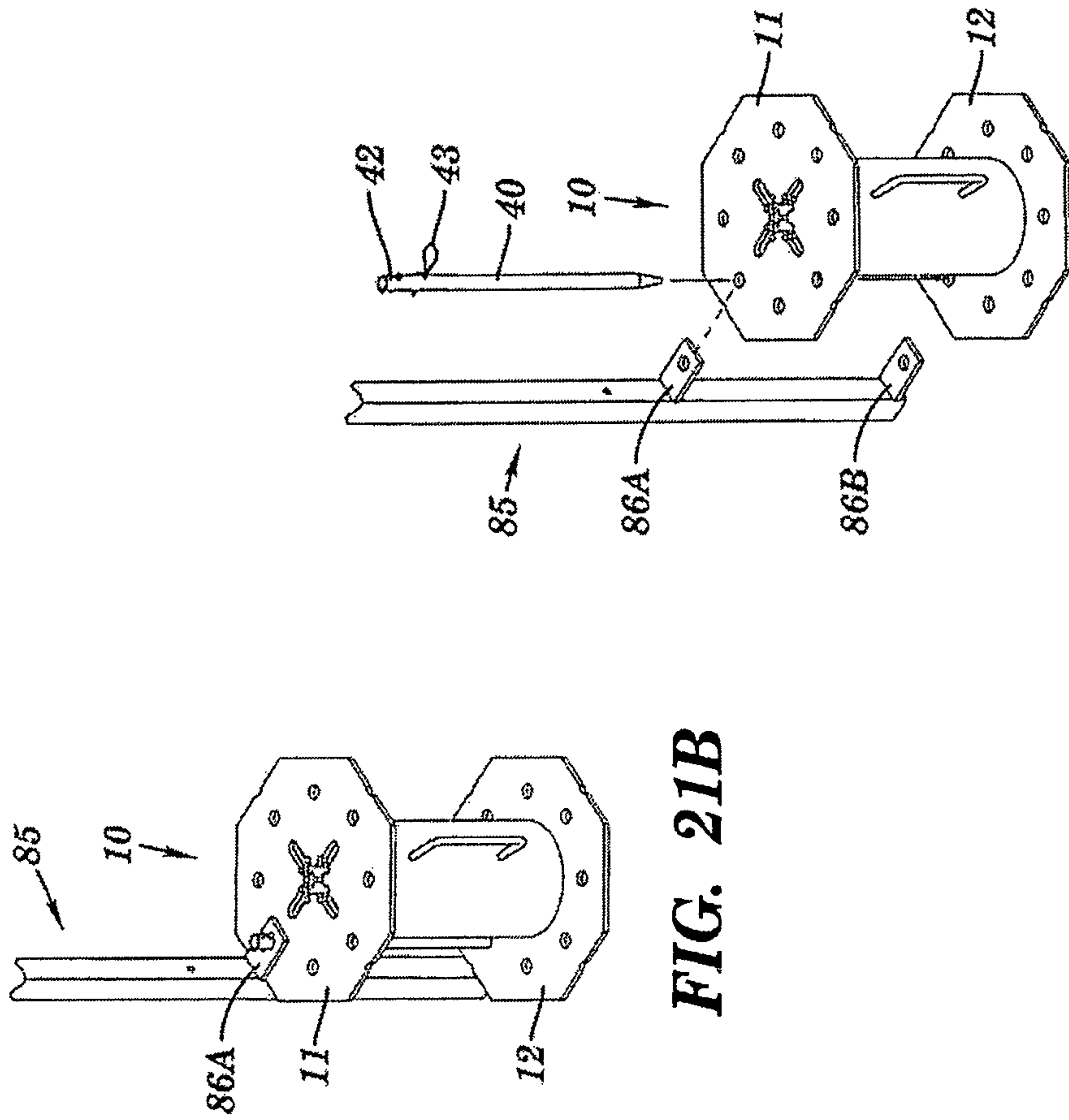

FIG. 20B



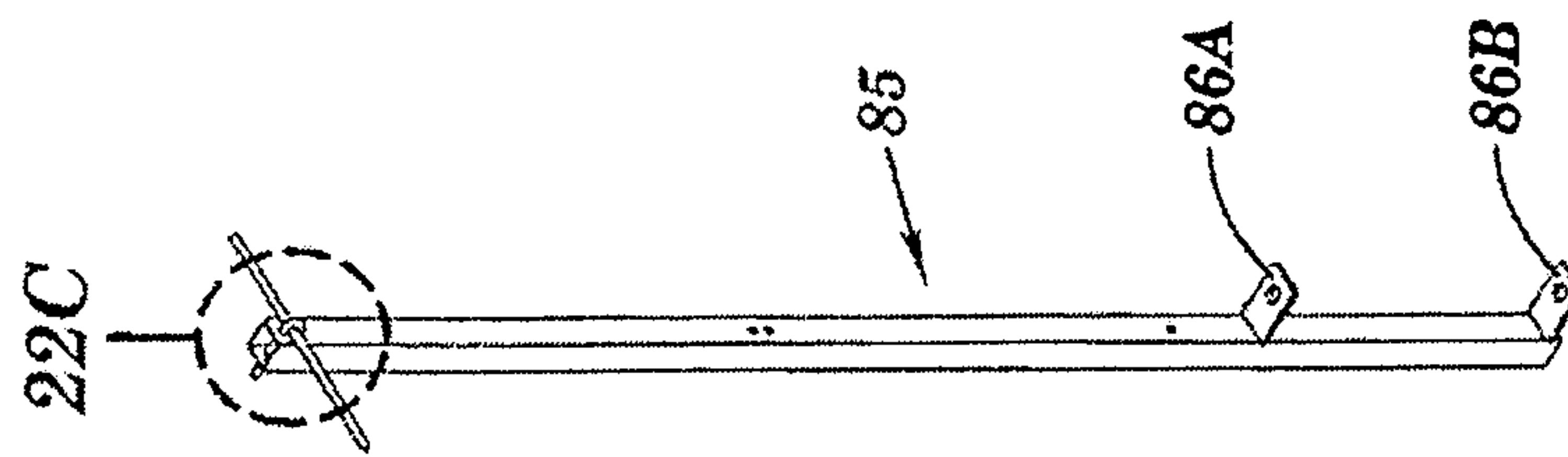

FIG. 22A

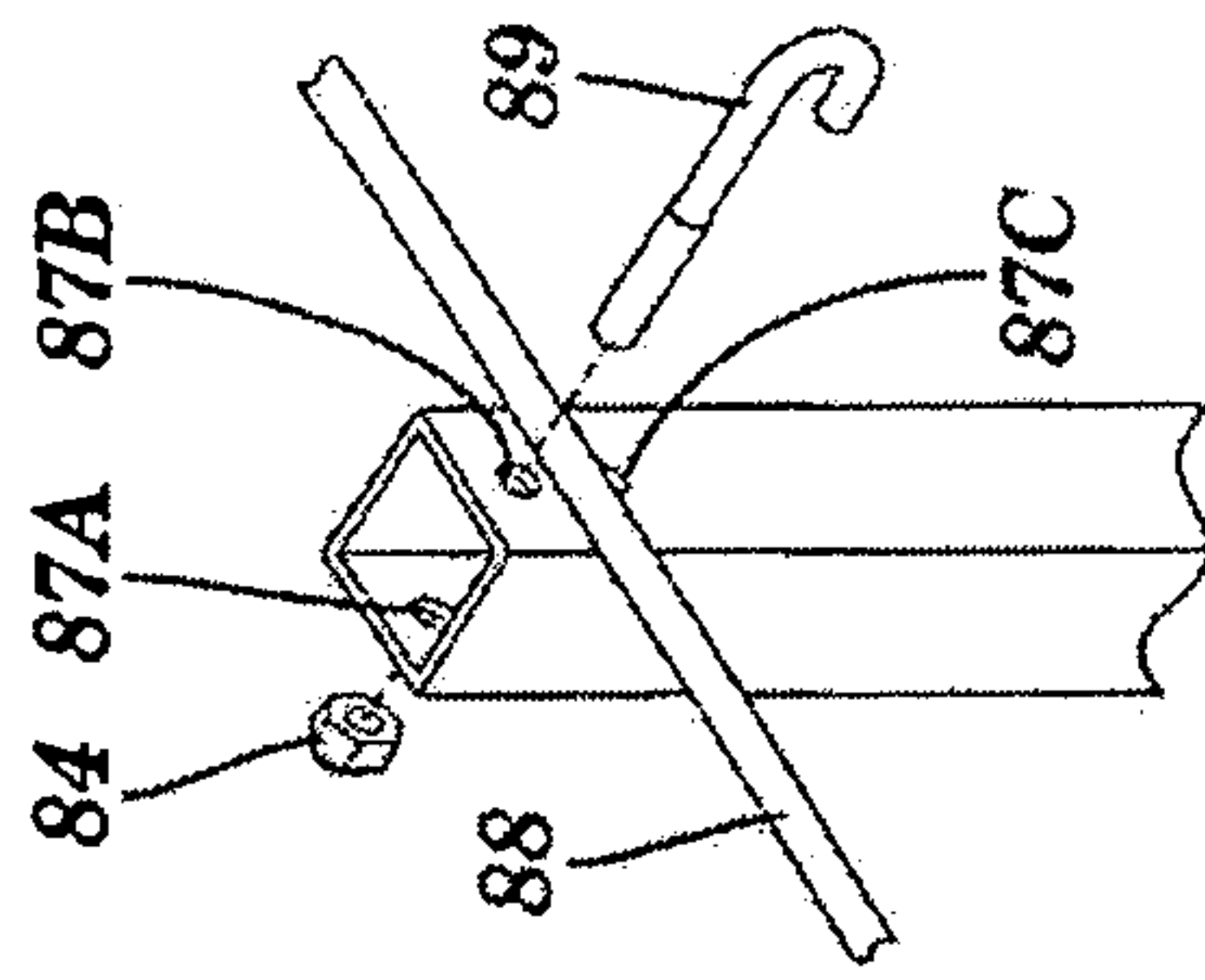

FIG. 22B

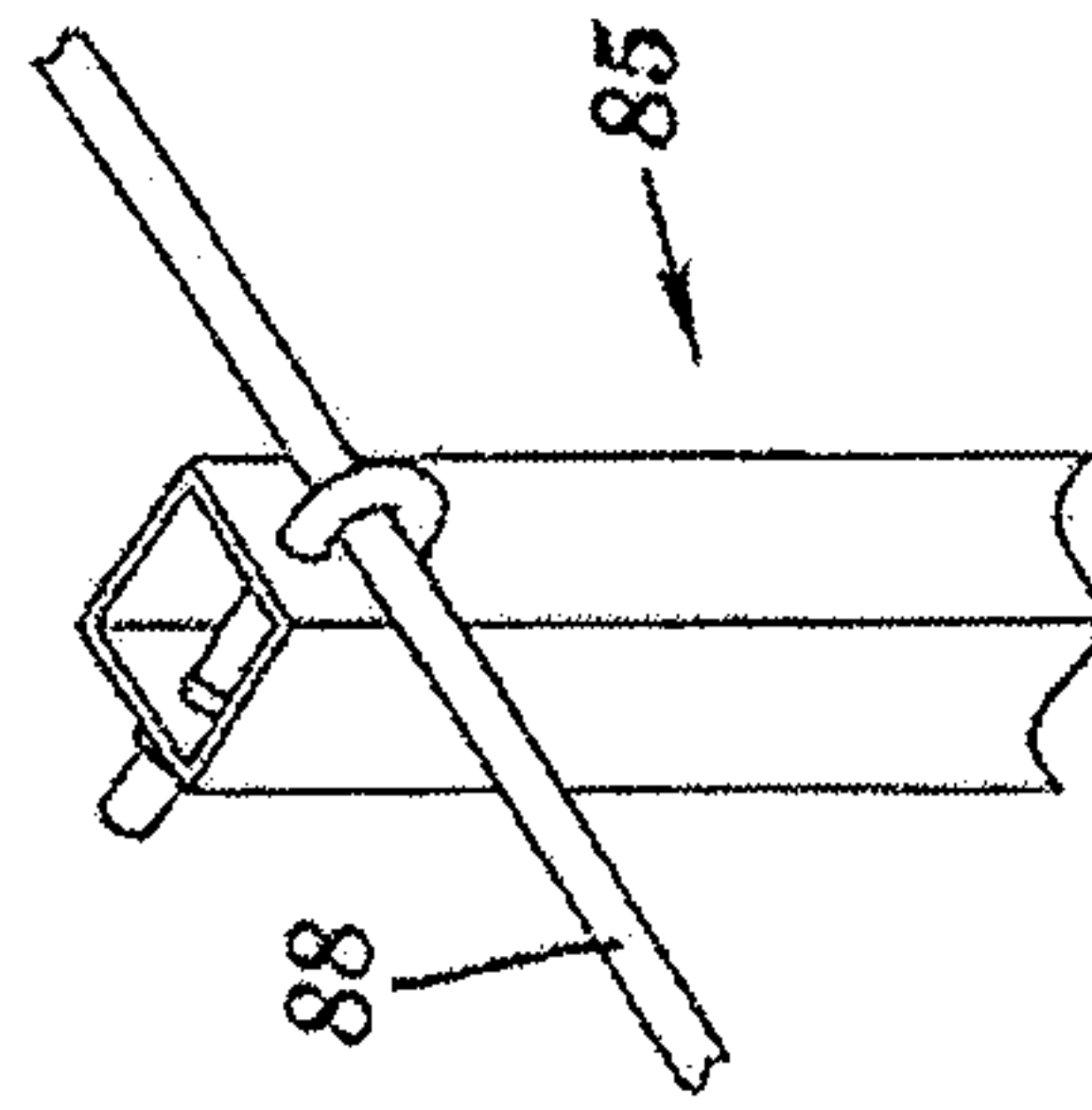

FIG. 22C

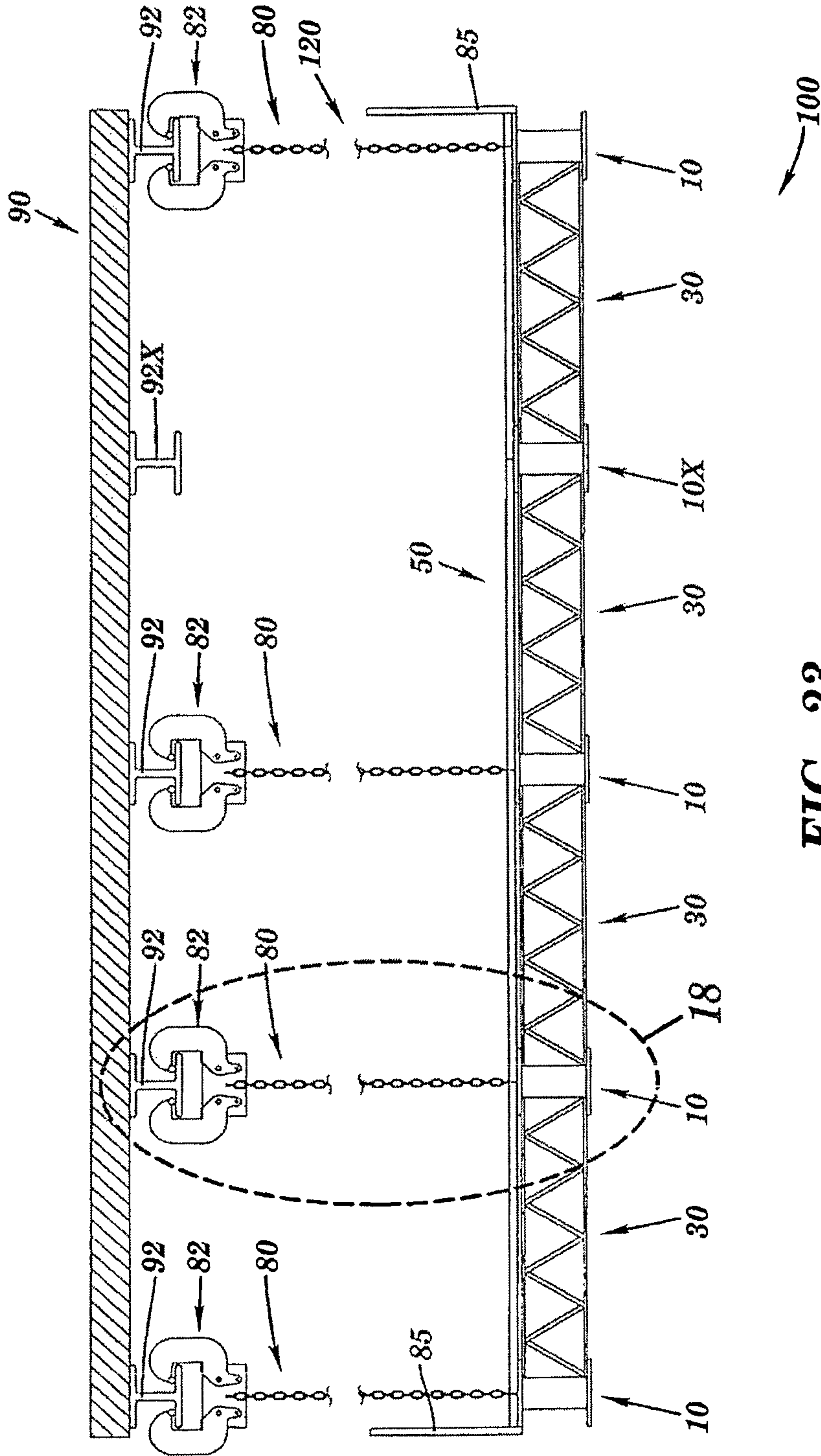

FIG. 23

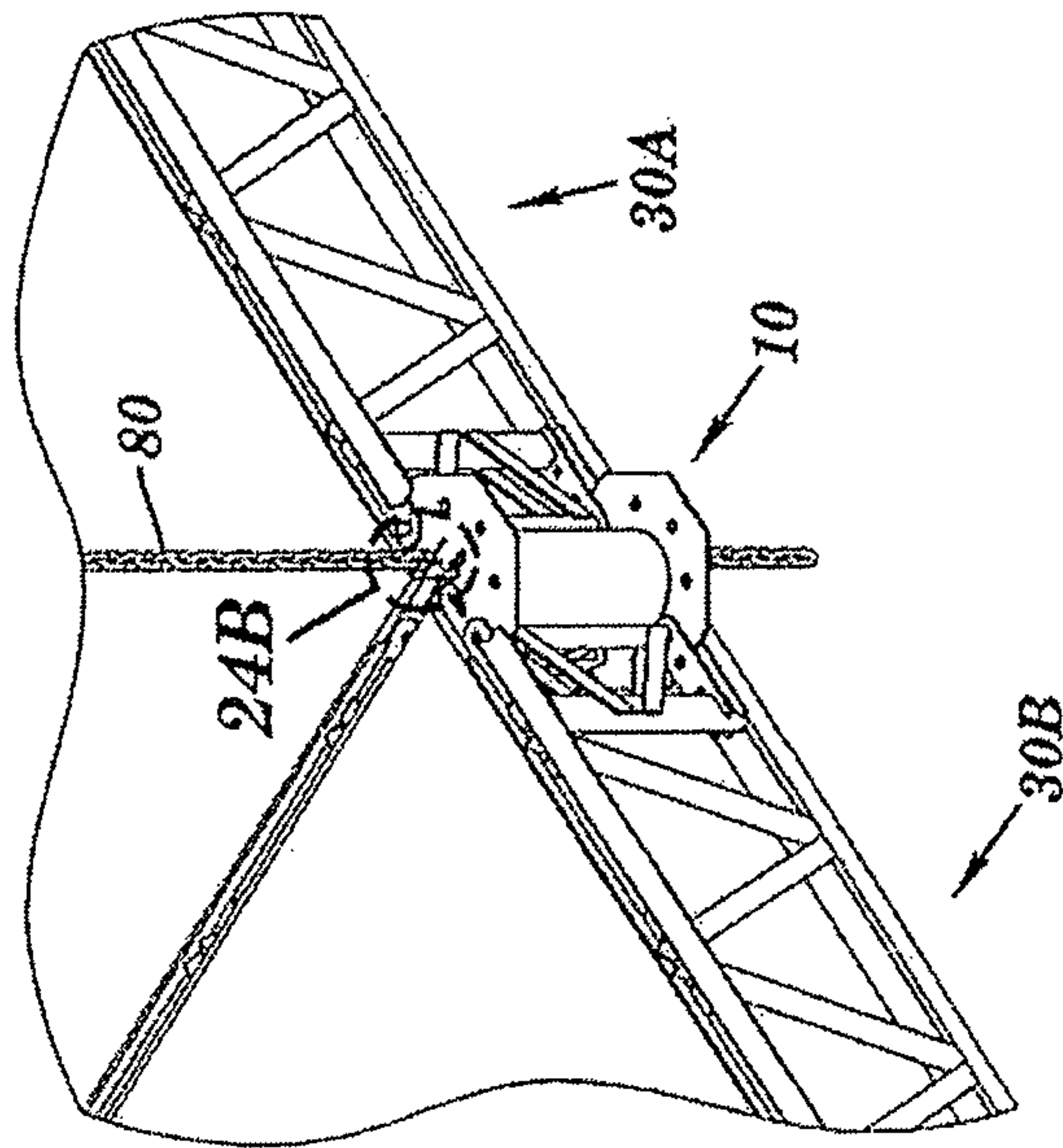

FIG. 24A

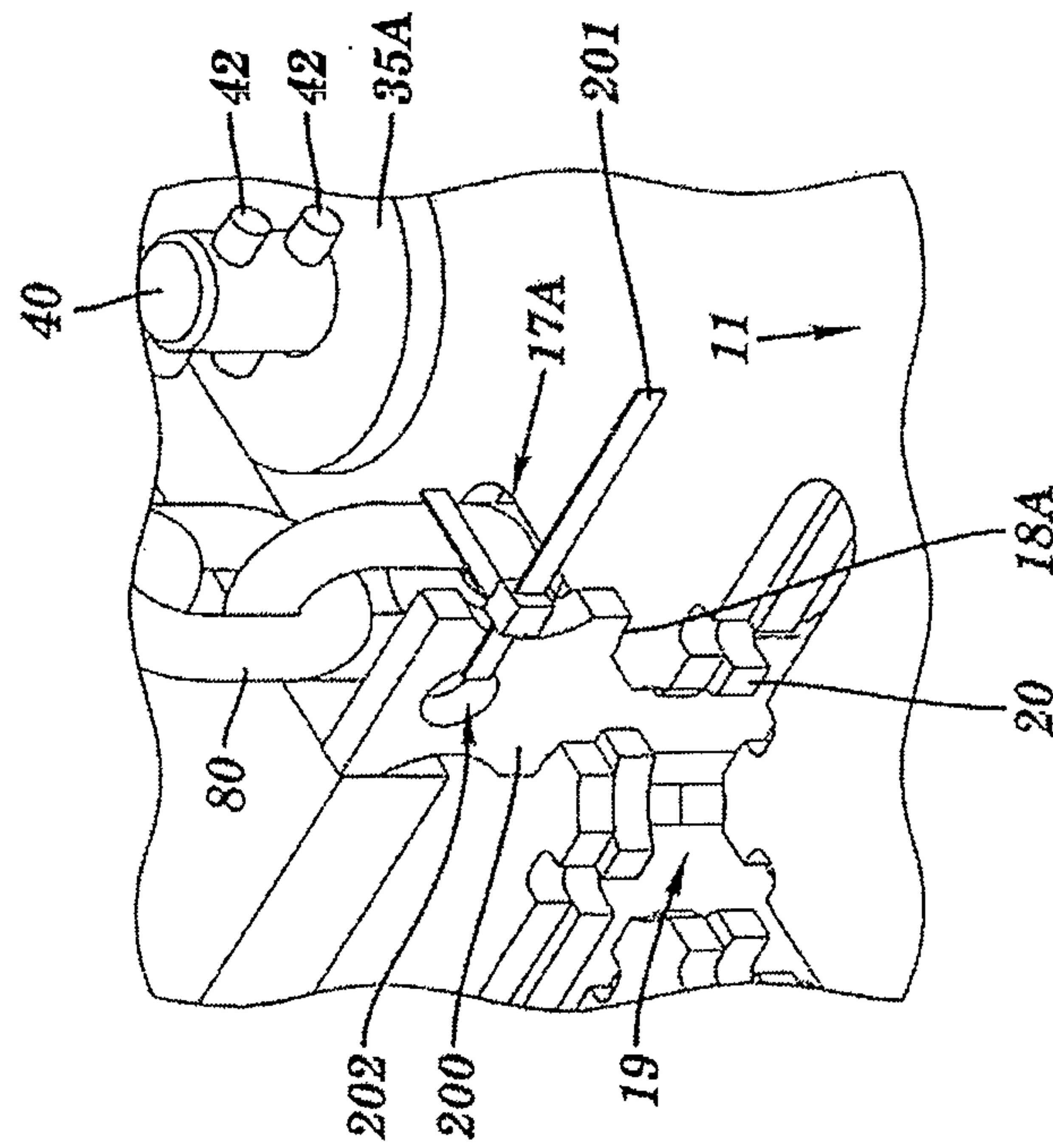

FIG. 24B

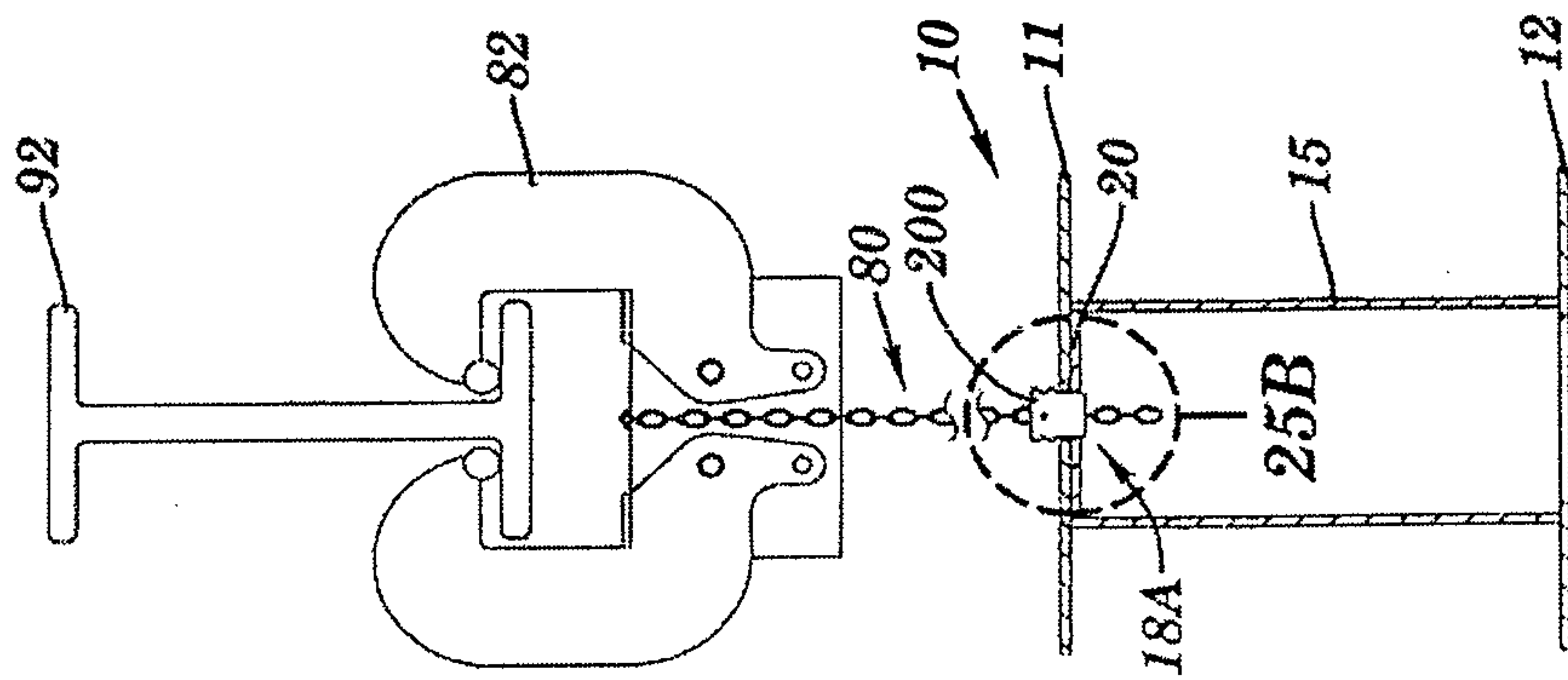

FIG. 25A

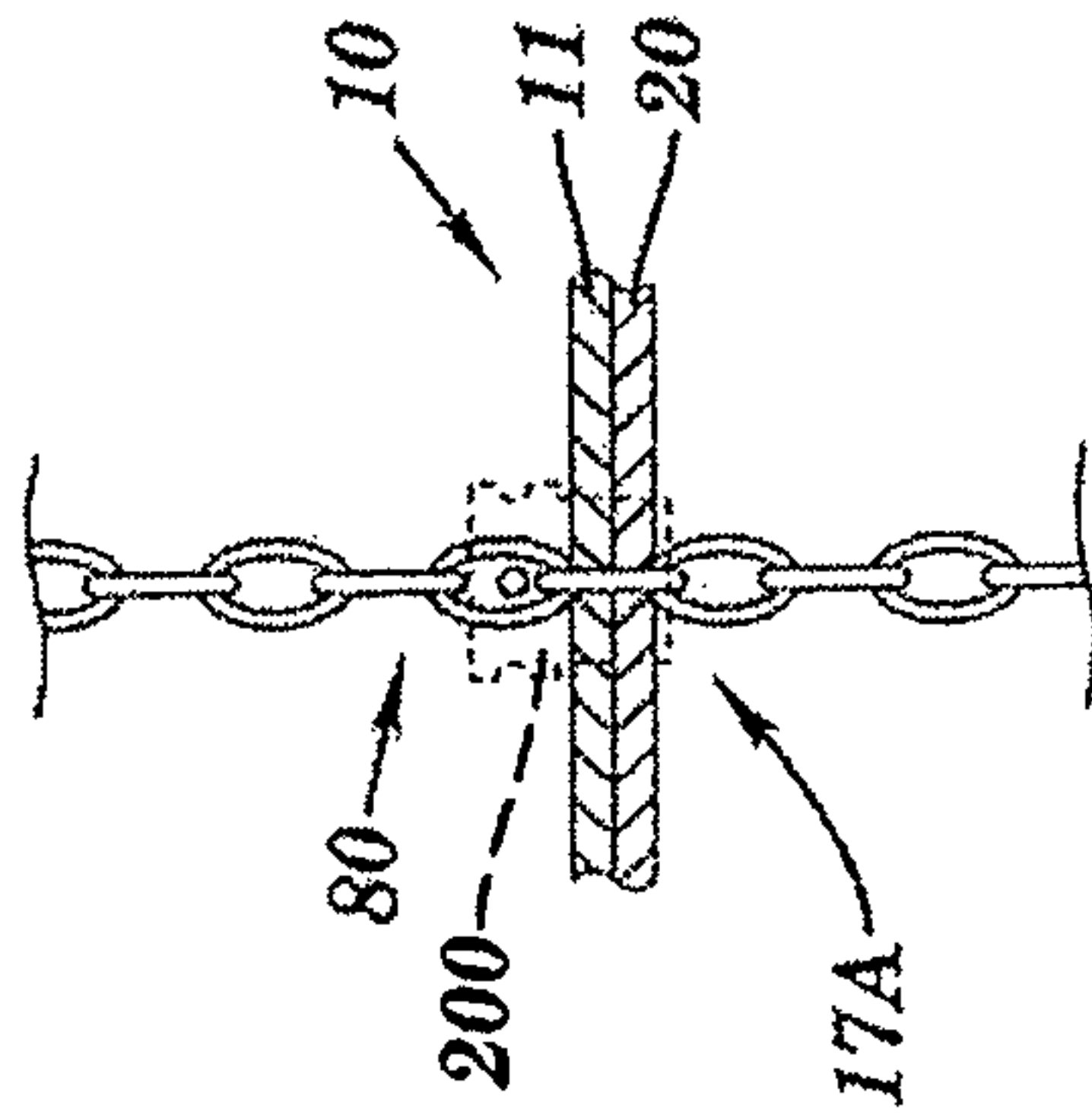

FIG. 25B

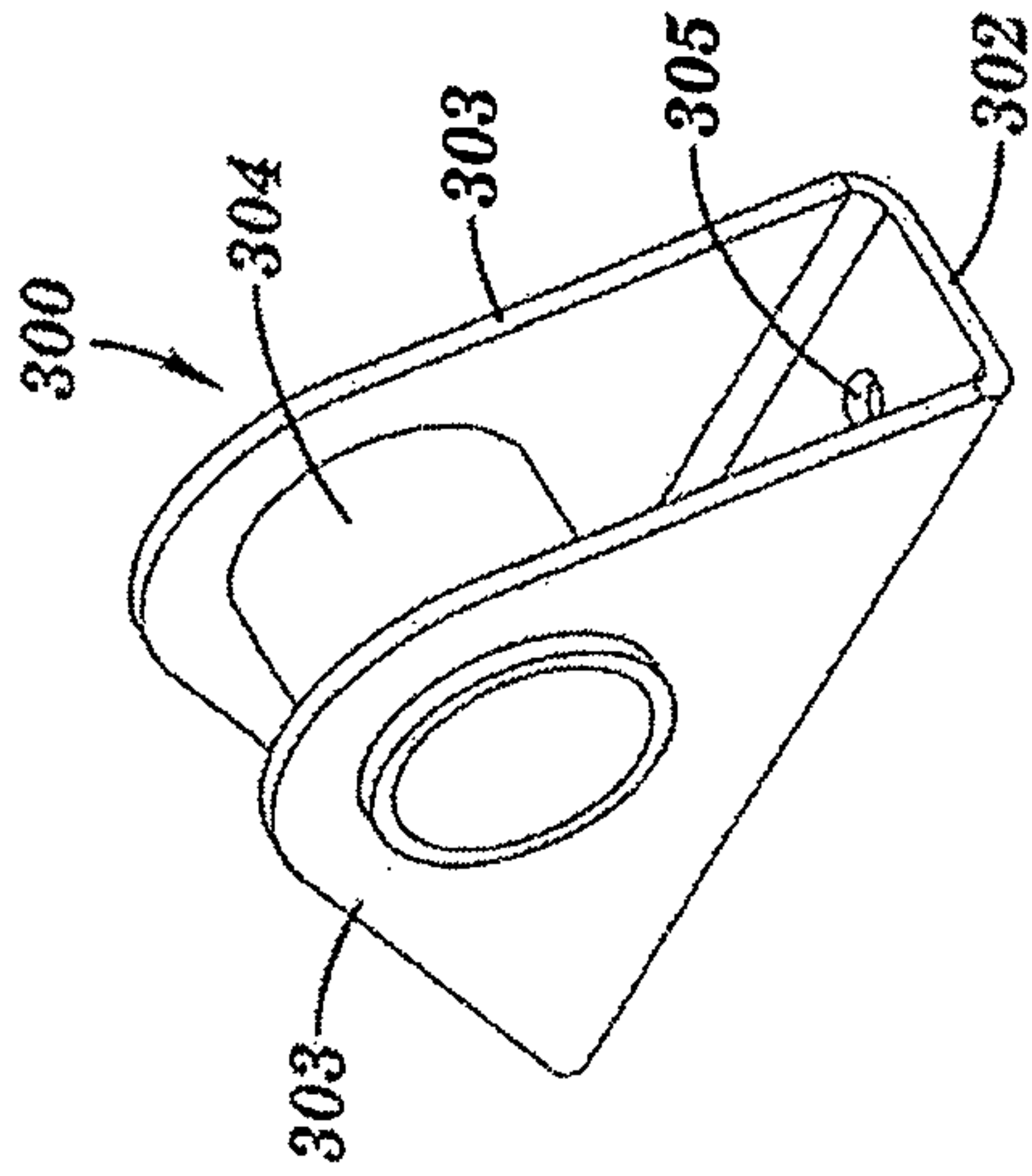

FIG. 26A

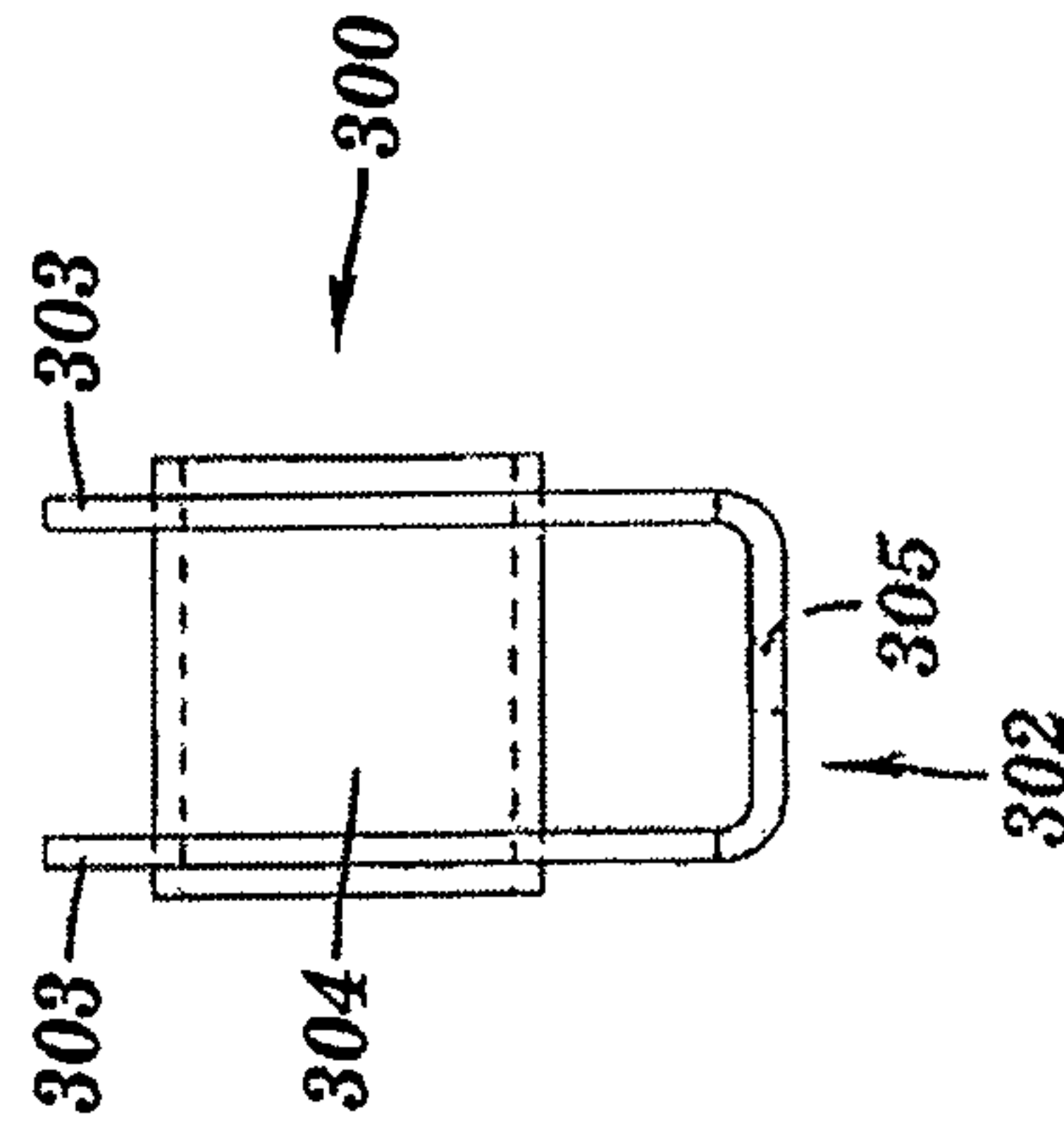

FIG. 26C

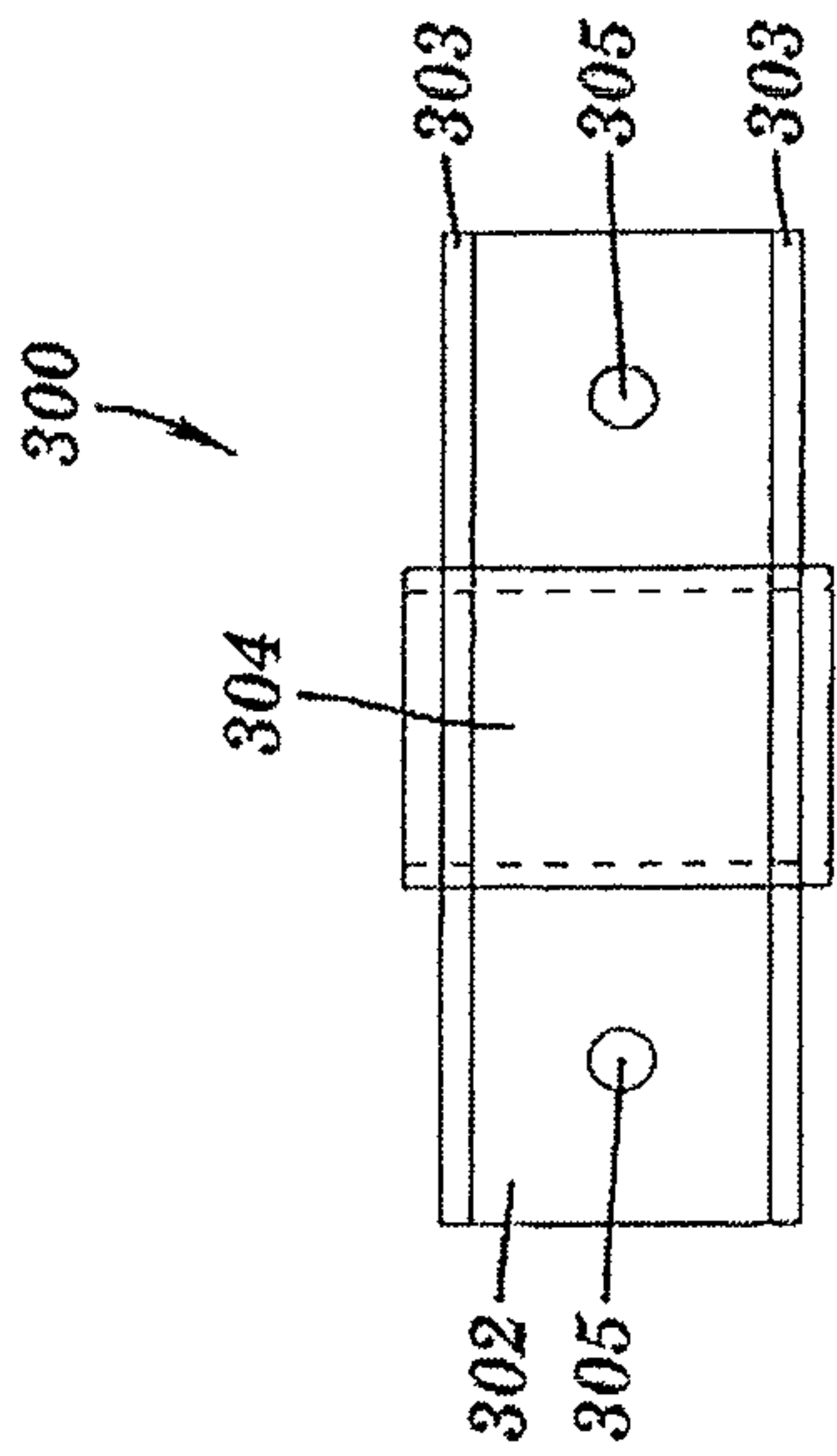

FIG. 26B

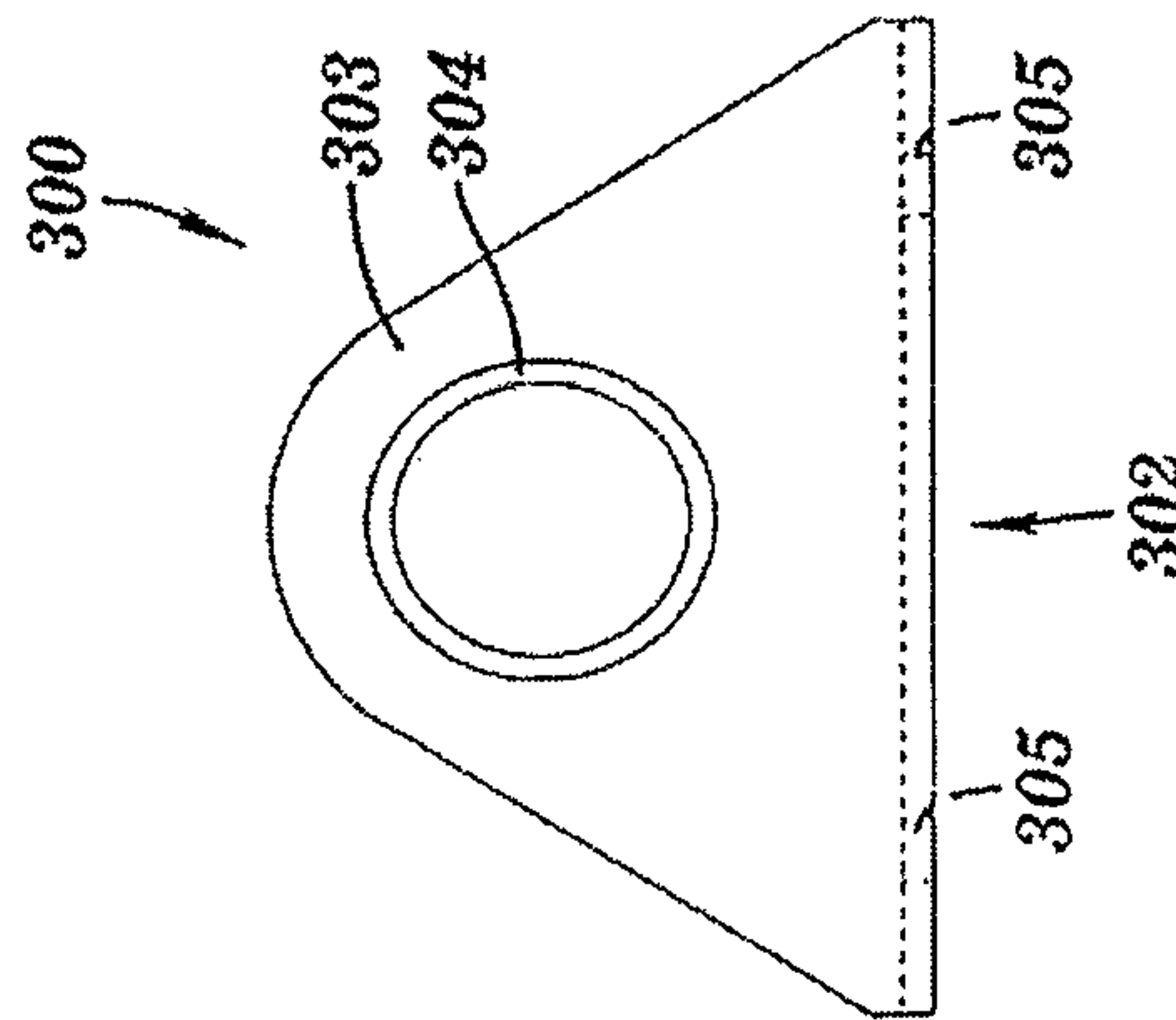

FIG. 26D

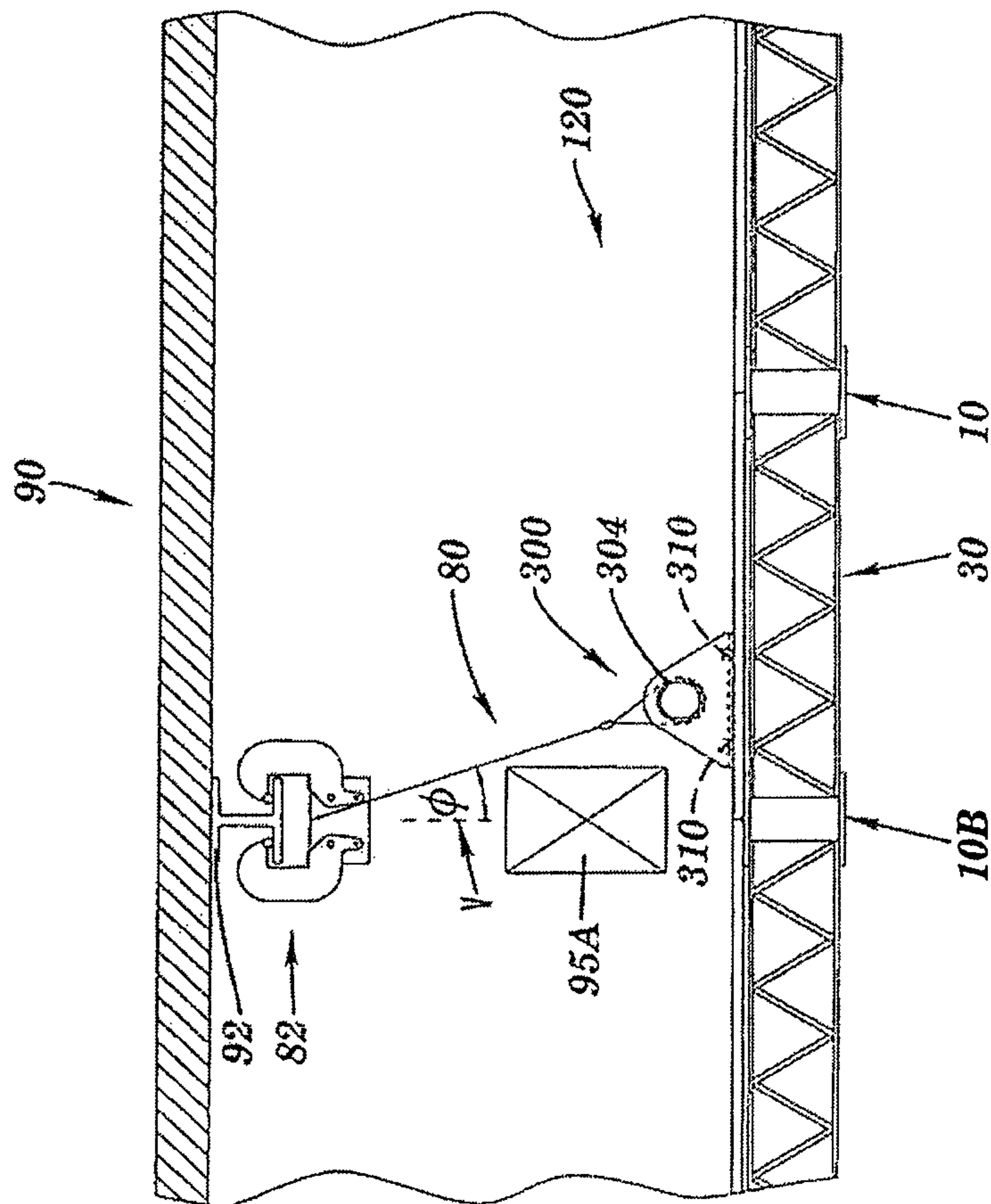

FIG. 27

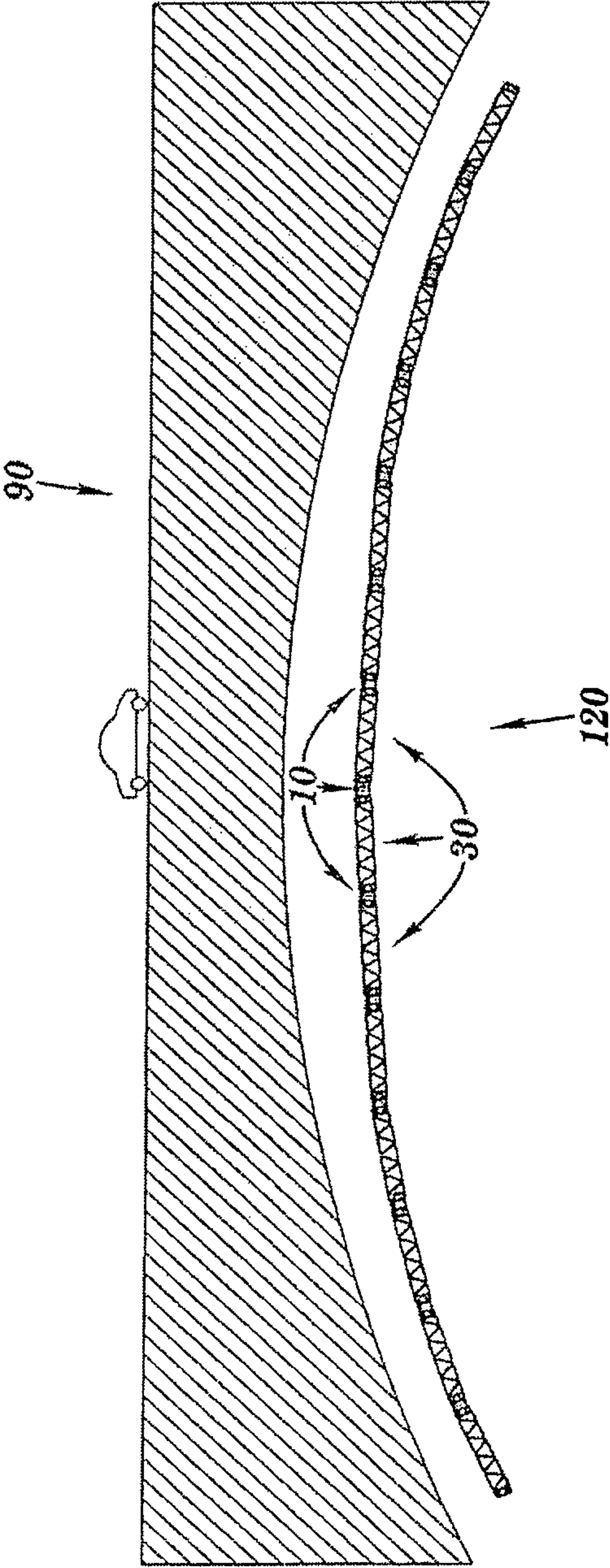

FIG. 28A

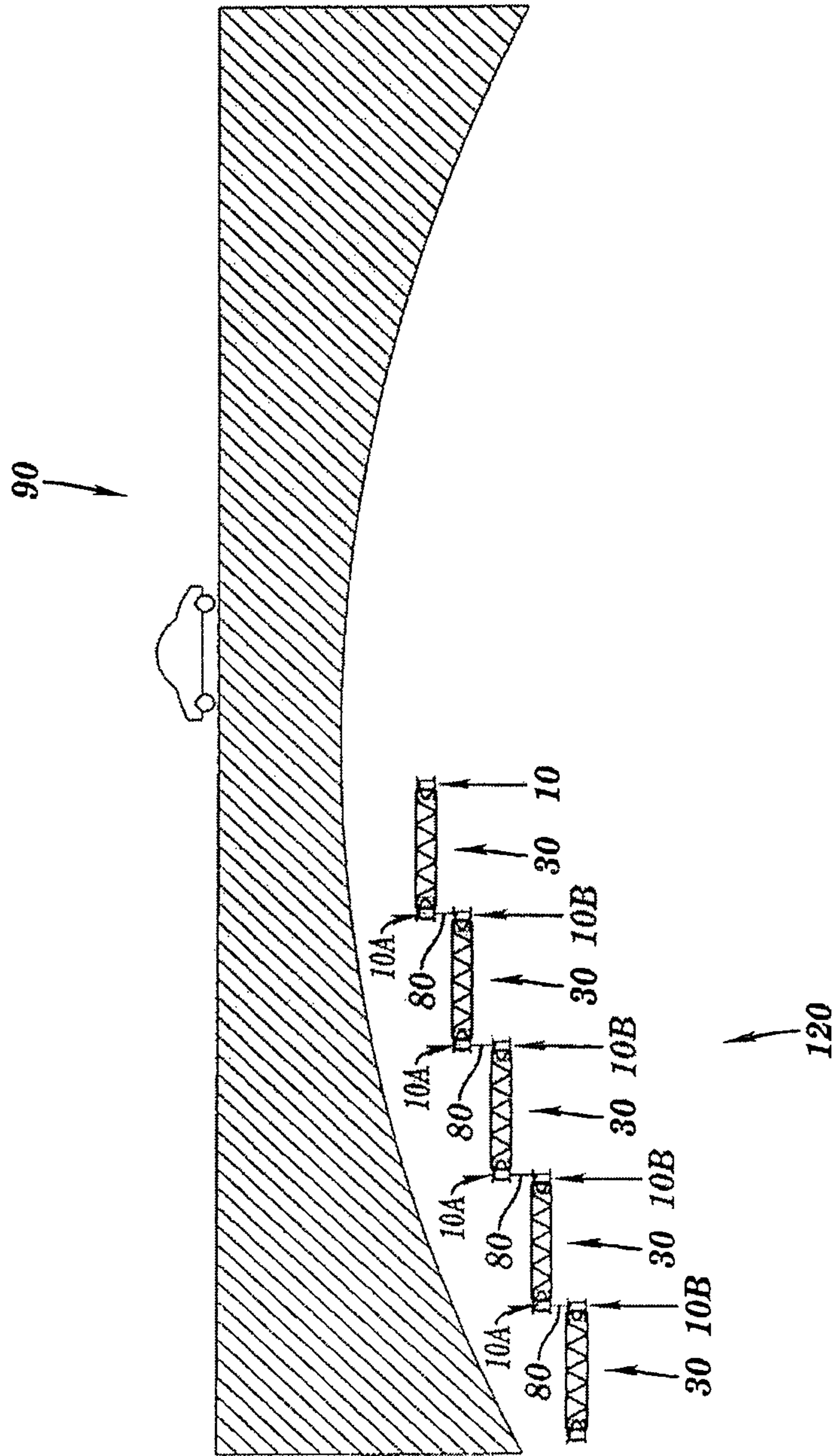

FIG. 28B

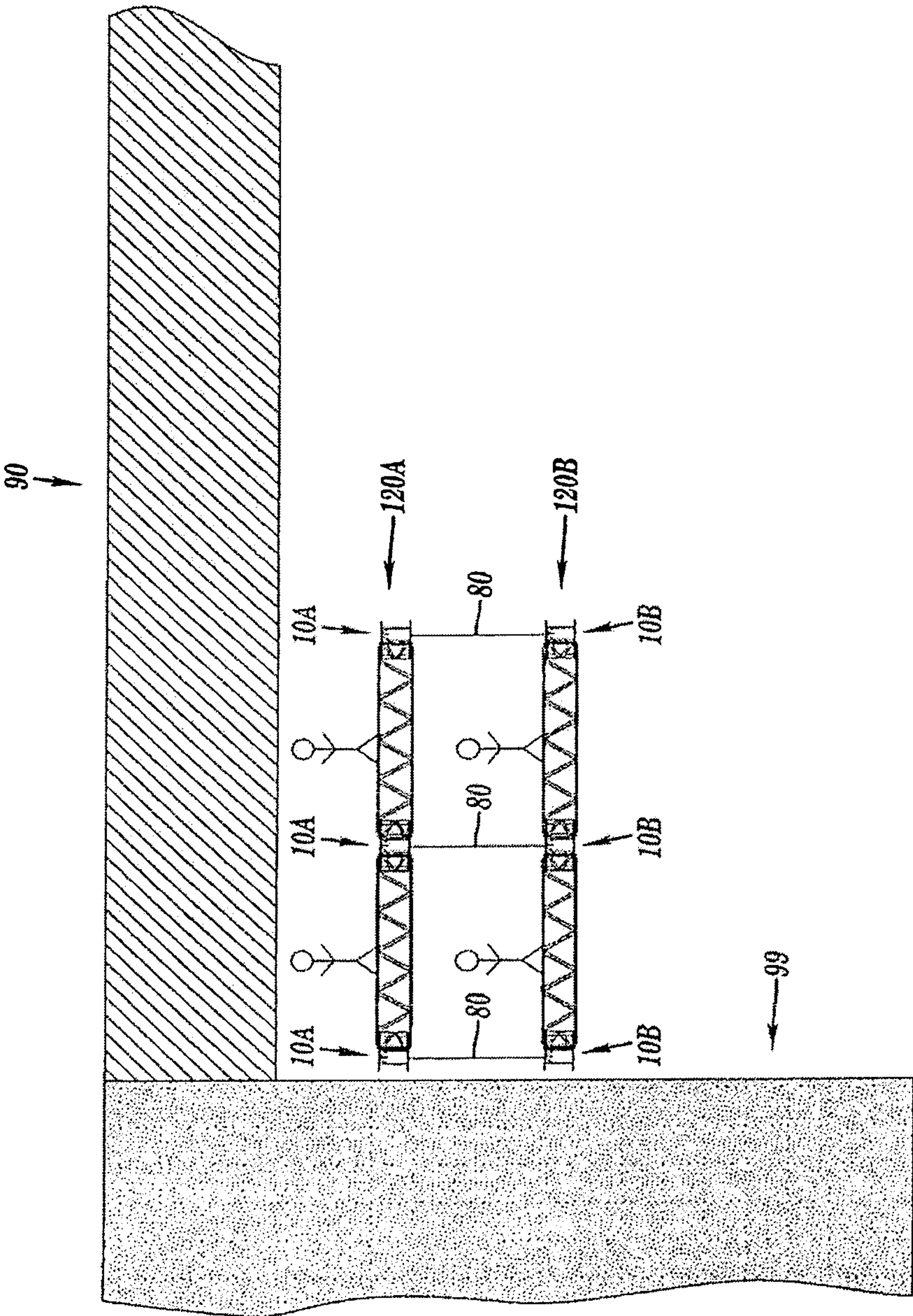

FIG. 28C

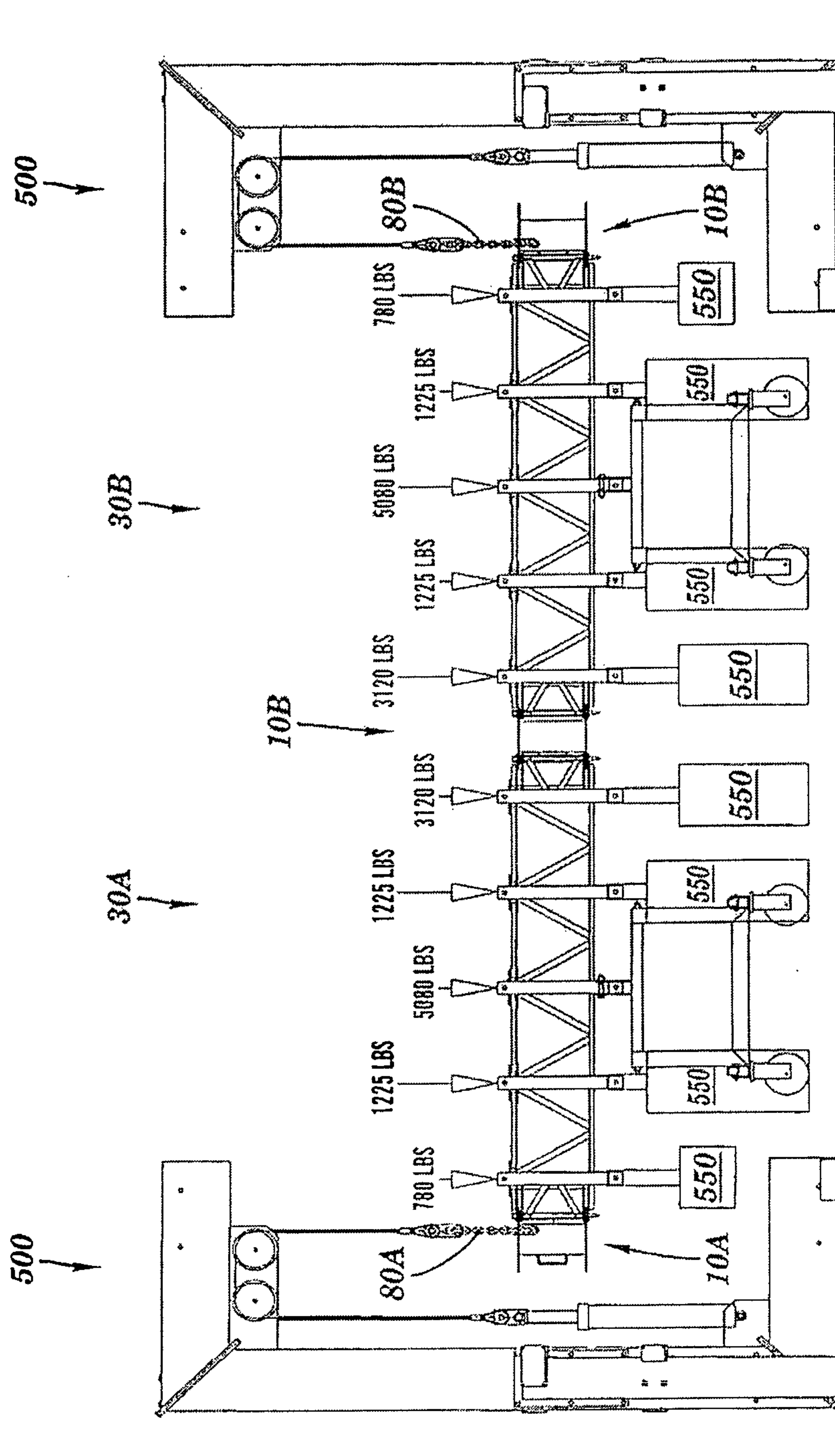

FIG. 29

**ARTICULATING WORK PLATFORM
SUPPORT SYSTEM, WORK PLATFORM
SYSTEM, AND METHODS OF USE THEREOF**

CROSS-REFERENCE TO RELATED
APPLICATIONS

This Continuation Patent Application claims the benefit of pending U.S. Divisional patent application Ser. No. 12/853,921 filed Aug. 10, 2010, and U.S. patent application Ser. No. 10/814,945, filed Mar. 31, 2004 now U.S. Pat. No. 7,779,599, both titled "Articulating Work Platform Support System, Work Platform System and Methods of Use Thereof", and both of which are incorporated by reference in their entireties herein.

BACKGROUND OF THE INVENTION

1. Technical Field

The invention relates, generally, to the field of construction and temporary work platforms that are erected to access various parts of various structures. Specifically, the invention relates to a unique articulating work platform support system, a work platform system, the various pieces of such systems and methods of using and manufacturing the same.

2. Related Art

Current work platform structures suffer from numerous deficiencies and shortcomings. Paramount to all work platforms that are suspended above the ground is the safety of the workers using them. For all work platform systems, in order to be legal, must meet numerous regulations promulgated by the U.S. Department of Labor Occupational Safety and Health Administration (i.e., "OSHA"). Many work platform systems currently used in the marketplace are believed to not meet all of these OSHA regulations.

Additionally, in the construction industry, costs are always of significant importance. Whether the construction project is a public works project (e.g., low bid), or a private project, reducing and/or maintaining costs is critical to the contractor(s) and the owner. Reducing labor, material, and/or equipment costs all help to address the all important cost.

In the area of work platforms and support systems, a significant portion of the cost is for the labor to erect and disassemble.

Some current work platform systems, require full assembly remote from the final installation location (e.g., on the ground; in a construction "yard", etc.), and then transporting (e.g., jacking, winching, lifting, moving, etc.) the assembled work platform into its requisite final location on the job site. This "build-then-move" aspect of many work platform systems is time consuming and requires significant labor and equipment to complete.

In summary, a need exists to overcome the above stated, and other, deficiencies in the art of work platform and work platform support systems. A need exists for an improved system that clearly meets, and exceeds, all OSHA regulations, while also requiring reduced time, labor, and equipment, to assemble, move, extend, and disassemble.

SUMMARY OF THE INVENTION

To overcome the aforementioned, and other, deficiencies, the present invention provides a device for use with work platform system, a work platform support system, a work platform system, and a method of manufacturing and installing same.

In a first general aspect, the present invention provides an apparatus comprising: a plurality of joists; and a plurality of hubs pivotally attached to said plurality of joists, wherein said plurality of hubs are adapted to receive a work platform.

5 In a second general aspect, the present invention provides a work platform support system comprising:

a plurality of joists;

a plurality of hubs, wherein each hub operatively connects to at least two joists; and

10 further wherein said system is configured to be articulating.

In a third general aspect, the present invention provides a work platform system comprising:

a plurality of joists;

15 a plurality of hubs, wherein each hub pivotally connects to at least two joists; and

at least one work platform which rests on at least one of said plurality of joists, said plurality of hubs, or a combination thereof.

20 In a fourth general aspect, the present invention provides a device for interconnecting with at least one joist of a work platform support system comprising:

a first surface with a first set of openings;

a second surface substantially parallel to said first surface, said second surface having a second set of openings; and

25 a structural element interspersed between said first surface and said second surface, wherein at least one of said first set and said second set of openings is adapted to provide an articulation of said device when interconnected with said at least one joist.

30 In a fifth general aspect, the present invention provides a work platform system comprising:

at least one hub;

at least one joist interconnected with said at least one hub; and

35 at least one section formed from said at least one hub and said at least one joist, wherein said at least one section can be articulated from a first position into a second position, further wherein said at least one section is capable of supporting without failure its own weight and at least about four times the maximum intended load applied or transmitted to it.

40 In a sixth general aspect, the present invention provides a work platform system for suspending a work platform from a structure, said system comprising:

a plurality of joists;

45 at least one hub for interconnecting at least two of said plurality of joists, wherein said at least two joists may articulate; and

a suspension connector for suspending said system from said structure.

50 In a seventh general aspect, the present invention provides method comprising:

providing a plurality of joists; and

55 pivotally attaching at least one hub to at least two of said plurality of joists, wherein said at least one hub is adapted to receive a work platform.

In a eighth general aspect, the present invention provides a method of installing a work platform support system to a structure comprising:

providing a plurality of joists;

60 providing at least one hub;

pivotally attaching at least one hub to said plurality of joists; and

suspending said at least one hub from said structure.

65 In a ninth general aspect, the present invention provides method of extending a second work platform system from a first, suspended work platform system, said method comprising:

attaching a plurality of joists to said first system;
 attaching a plurality of hubs to said plurality of joists;
 articulating said plurality of joists and plurality of hubs,
 thereby forming said extending second work platform system.

The foregoing and other features and advantages of the invention will be apparent from the following more particular description of embodiments of the invention. It is to be understood that both the foregoing general description and the following detailed description are exemplary, but are not restrictive, of the invention.

BRIEF DESCRIPTION OF THE DRAWINGS

The features of the present invention will best be understood from a detailed description of the invention and an embodiment thereof selected for the purposes of illustration and shown in the accompanying drawings in which:

FIG. 1 is top perspective view of a hub, in accordance with the present invention;

FIG. 2 is top view of a hub, in accordance with the present invention;

FIG. 3 is a side elevation view of an embodiment of a hub, in accordance with the present invention;

FIG. 4 is bottom view of a hub, in accordance with the present invention;

FIG. 5 is a top perspective view of a hub and joist, in accordance with the present invention;

FIG. 6A is an exploded top perspective view of an interconnection between a hub and joist, in accordance with the present invention;

FIG. 6B is a top perspective view of the view in FIG. 6A, in accordance with the present invention;

FIG. 7 is a top perspective view of a work platform support system, in accordance with the present invention;

FIG. 8A is a top perspective view of an interconnection between a joist and deck support, in accordance with the present invention;

FIG. 8B is a exploded reverse top perspective view of an interconnection between a joist and deck support, in accordance with the present invention;

FIG. 8C is a close-up top perspective view of an interconnection between a joist and deck support, in accordance with the present invention;

FIG. 9 is a top perspective view of a work platform support system and work platform system, in accordance with the present invention;

FIG. 10 is a top perspective view of a second embodiment of a work platform support system and work platform system, in accordance with the present invention;

FIG. 11A is a top perspective view of a joist, hub, and portion of a deck retainer assembly, in accordance with the present invention;

FIG. 11B is an exploded close-up perspective view of a joist, hub, and portion of a deck retainer assembly, in accordance with the present invention;

FIG. 11C is an end sectional view of a joist and a portion of a deck retainer assembly, in accordance with the present invention;

FIG. 12 is a top perspective view of a third embodiment of a work platform support system and work platform system, in accordance with the present invention;

FIG. 13 is a bottom perspective view of the embodiment shown in FIG. 12, in accordance with the present invention;

FIG. 14 is a top perspective view of a work platform system and a work platform support system prior to articulation, in accordance with the present invention;

FIG. 15 is a top perspective view of the embodiment in FIG. 14 undergoing articulation, in accordance with the present invention;

FIG. 16 is a top perspective view of the embodiment in FIG. 15 undergoing further articulation, in accordance with the present invention;

FIG. 17 is a top perspective view of the embodiment in FIG. 16 undergoing further articulation, in accordance with the present invention;

FIG. 18 is a top perspective view of the embodiment in FIG. 14 having completed articulation, in accordance with the present invention;

FIG. 19A is a top perspective view of a joist and hub assembly, in accordance with the present invention;

FIG. 19B is a top perspective view of a second embodiment of a joist and hub assembly, in accordance with the present invention;

FIG. 19C is a top perspective view of a third embodiment of a joist and hub assembly, in accordance with the present invention;

FIG. 19D is a top perspective view of a fourth embodiment of a joist and hub assembly, in accordance with the present invention;

FIG. 20A is a plan view of a curved work platform support system, in accordance with the present invention;

FIG. 20B is a plan view of an angled work platform support system, in accordance with the present invention;

FIG. 21A is a top perspective view of an interconnection between a hub and a railing standard, in accordance with the present invention;

FIG. 21B is a close-up of FIG. 21A, in accordance with the present invention;

FIG. 21C is an exploded view of FIG. 21B, in accordance with the present invention;

FIG. 22A is a top perspective view of a railing standard and railing, in accordance with the present invention;

FIG. 22B is an exploded view of FIG. 22C, in accordance with the present invention;

FIG. 22C is a close up top perspective view of an interconnection between a railing standard and railing, in accordance with the present invention;

FIG. 23 is a sectional elevation view of a work platform support system and work platform system attached to a structure, in accordance with the present invention;

FIG. 24A is a top perspective view of an interface between a hub and a suspension connector, in accordance with the present invention;

FIG. 24B is a close-up the interface shown in FIG. 24A, in accordance with the present invention;

FIG. 25A is a sectional elevation view of a hub, suspension connector, and structure attachment device, in accordance with the present invention;

FIG. 25B is a close-up sectional elevation view the interconnection between the hub and suspension connector, in accordance with the present invention;

FIG. 26A is a top, perspective view of an auxiliary suspender mounting bracket, in accordance with the present invention;

FIG. 26B is a plan view of an auxiliary suspender mounting bracket, in accordance with the present invention;

FIG. 26C is a front elevation view of an auxiliary suspender mounting bracket, in accordance with the present invention;

FIG. 26D is a side elevation view of an auxiliary suspender mounting bracket, in accordance with the present invention;

5

FIG. 27 is an elevation sectional view showing suspension of a work platform system from a structure via an auxiliary suspender mounting bracket, in accordance with the present invention;

FIG. 28A is an elevation view of a work platform system suspended under an arched bridge, in accordance with the present invention;

FIG. 28B is an elevation view of a second embodiment of a work platform system suspended under an arched bridge, in accordance with the present invention;

FIG. 28C is an elevation view of a multi-leveled work platform system suspended under a structure, in accordance with the present invention; and

FIG. 29 is an elevation view of load test set up conducted on an embodiment of the present invention.

DETAILED DESCRIPTION OF THE INVENTION

Although certain preferred embodiments of the present invention will be shown and described in detail, it should be understood that various changes and modifications may be made without departing from the scope of the appended claims. The scope of the present invention will in no way be limited to the number of constituting components, the materials thereof, the shapes thereof, the relative arrangement thereof, etc., and are disclosed simply as an example of an embodiment. The features and advantages of the present invention are illustrated in detail in the accompanying drawings, wherein like reference numerals refer to like elements throughout the drawings.

As a preface to the detailed description, it should be noted that, as used in this specification and the appended claims, the singular forms “a”, “an” and “the” include plural referents, unless the context clearly dictates otherwise.

Referring now to the drawings, FIG. 1 illustrates a portion of the present invention, namely a hub, herein denoted by a 10. The hub 10 which connects with a joist 30 (See e.g., FIG. 5), makes up in integral portion of a work platform support system and work platform system. A joist is any elongate structural member adapted for bearing or supporting a load, such as a bar joist, truss, shaped-steel (i.e., I-beam, C-beam, etc.), or the like. The hub 10 is configured so that, when attached to a joist 30, allows for articulation of both the hub 10 and the joist 30. A hub is an interconnection structure, such as a node, hinge, pivot, post, column, center, shaft, spindle, or the like. Articulation, as used herein, is defined as the capability to swing, and/or rotate, about a pivot point or axis. As will be discussed in more detail below, this articulation feature inter alia allows for less manpower to readily assemble and disassemble components of the system in, or near, the desired finished position.

The hub 10 includes a top element 11 and a bottom element 12 spaced at distal ends of a middle section 15. The top element 11 and bottom element 12 may be substantially planar in configuration, as well as, being parallel to each other. The top element 11 and bottom element 12, in the embodiment shown, are octagonal in plan. The middle section 15 may be a cylindrical section wherein a longitudinal axis of the middle section 15 is normal to the planes of the top element 11 and bottom element 12. In the embodiment shown, the middle section 15 is a right circular cylinder. In FIG. 1, a lower portion of the middle section 15 is removed for clarity purposes to show that the middle section 15 is hollow.

There are a plurality of openings 13, 14, extending through both the top element 11 and bottom element 12, respectively. The plurality of openings 13 (e.g., 13A, 13B, 13C, 13D, 13E, 13F, 13G, 13H) are interspersed on the top element 11 so as to

6

offer various locations for connecting to one, or more, joists 30 (see e.g., FIG. 5). The plurality of openings 14 (e.g., 14A, 14B, 14C, 14D, 14E, 14F, 14G, 14H) are similarly spaced on the bottom element 12 so that respective openings (e.g., 13A and 14A) are coaxial.

At the center of the top element 11 is a center opening 16 which is configured to receive suspension connector (See e.g., FIGS. 22, 23A, 24A, 24B). The center opening 16 may be generally cruciform in configuration due to its center opening area 19 with four slots 17 (e.g., 17A, 17B, 17C, 17D) extending therefrom. Transverse to each of the four slots 17A, 17B, 17C, 17D, and interconnected thereto, are a series of cross slots 18A, 18B, 18C, 18D, whose utility will be apparent as discussed below. For added strength a second reinforcing plate 20 is added to the underside of the top element 11 wherein openings on the reinforcing plate 20 correspond to the center opening 16 configuration and all the ancillary openings thereto (17, 18, 19). A handle 22 is optionally added to the side of the middle section 15.

FIGS. 2, 3, and 4 show the top, side, and bottom view of the same embodiment of the hub 10 depicted in FIG. 1. FIG. 4 shows inter alia a bottom opening 23 on the bottom element 12. The bottom face of the reinforcing 20 can be seen within the bottom opening 23. Attached to the reinforcing 20 and the interior face of the middle section 15 are a plurality of gussets 25 that provide added support to the hub 10.

FIG. 5 depicts a top perspective view of the interconnection between a single hub 10 and a single joist 30, while FIGS. 6A and 6B shows a exploded close-up view, and a regular perspective close-up view, respectively, of a typical connection detail between the hub 10 and joist 30.

The joist 30 includes an upper element 32 and a bottom element 33. Interspersed between elements 32, 33 are a plurality of diagonal support members 38. Each element 32, 33 is made of two L-shaped pieces of angle iron 39A, 39B. Elements 32, 33 typically may be identical in construction, with the exception being upper element 32 includes connector holes 54A, 54B at its midspan (See e.g., FIGS. 8A, 8B). The joist 30 includes a first end 31A and a second end 31B. At either end 31A, 31B of both the upper element 32 and bottom element 33 extends an upper connecting flange 35 and a lower connecting flange 36. Through both upper and lower connection flanges 35, 36 are connecting holes 37. Thus, there are four upper connecting flanges 35A, 35B, 35C, 35D; four lower connecting flanges 36A, 36B, 36C, 36D. Thus, at a first end 31A, extending from the upper element 32, is an upper connection flange 35A and lower connection flange 36A, with a connecting hole 37A therethrough. Similarly, at the second end 31B of the upper element 32, extends an upper connection flange 35B and lower connection flange 36B, with a connecting hole 37B therethrough. Continuing, at the first end 31A of the lower element 33 extends an upper connection flange 35D and lower connection flange 36D. Through these connection flanges 35D, 36D are a connecting hole 37D. At the second end 31B of the joist 30 extending from the lower element 33 is an upper connection flange 35C and lower connection flange 36C with a connecting hole 37C therethrough.

Interior to each of the connector holes 37A, 37B, 37C, 37D are additional locking holes 360A, 360B, 360C, 360D also located on the connection flanges 35A, 35B, 35C, 35D.

As FIGS. 6A and 6B depict in further clarity, a pin 40 may be placed through the connecting holes 37 any two corresponding top and bottom openings 13, 14 of the hub 10. In this manner, the joist 30 can be connected in a virtually limitless number of ways, and angles, to the hub 10. For example, a pin 40 may be placed in through an upper connection flange 35A;

through an opening 13A; through a lower connection flange 36A (all of the first end 31A of the upper element 32); through an upper connection flange 35D; through an opening 14A; and, then through the lower connection flange 36D. In this scenario, the pin 40 further threads through connecting holes 37A and 37D. The pin 40 includes two roll pins 42 at its upper end. The lower of the two roll pins 42 acts as a stop, thereby preventing the pin 40 from slipping all the way through the joist 30 and hub 10. The upper roll pin 42 acts as a finger hold to allow easy purchase and removal of the pin 40 from the joist 30 and hub 10. The design of these various parts are such that free rotation of both the joist 30 and hub 10 is allowed, even while the joist 30 and hub 10 are connected together. Rotational arrow R_1 show the rotation of the joist 30, while rotational arrow R_2 shows the rotation of the hub 10. These rotational capabilities of the joist 30 and hub 10 provide, in part, the articulating capability of the present invention.

A second optional locking pin 40B may be added through the locking holes 360A, 360C, 360C, 360D at the end of joist 30 in order to lock the joist 30 to prevent articulation, if so desired. The locking pin 40B abuts a groove 24 on the hub 10. The grooves are situated on both the upper element 11 and lower element 12. Similarly, the locking pin 40B can include additional two roll pins 42 as does the pin 40.

It should be apparent to one skilled in the art, that while the joist 30 depicted in the figures is made of particular shaped elements, there are other embodiments that provide the aspects of the present invention. For example, the joist 30 in the figures may commonly be called a bar joist, or open-web beam or joist, the joist 30 could also be made of structural tubing. That is the joist 30 could be made of multiple pieces of structural tubing shapes; or, the joist 30 could be one single structural tubing shape. Similarly, the joist 30 could be made of shaped steel (e.g., wide flange elements, narrow flange members, etc.), or other suitable shapes and materials.

FIG. 7 depicts a section, or module, of a work platform support system 100 as constructed. Note that four hubs 10A, 10B, 10C, 10D are interconnected with four joists 30A, 30B, 30C, 30D. FIG. 7 shows a work platform support system 100 that is square in plan. It should be apparent to one skilled in the art, that other shapes and configurations can be made. By varying the lengths of joists 30, for example, other shapes can be made. For example, a work platform support system 100 that is rectangular can be constructed. Also, by attaching joists 30 to various openings 13, 14 of the hub 10, various angles at which the joists 30 interconnect with the hubs 10 can be achieved. For example, a work platform support system 100 that is triangular in plan (not shown) may be constructed. Thus, by changing joist 30 lengths (See e.g., FIGS. 19A-19D) and/or changing the angle(s) at which the joists 30 extend from the hubs 10, virtually any shape and size work platform support system 100 may be constructed. Further, different shape, size, and configuration of work platform support system 100 can be joined and abutted with each other, so that the work platform design is virtually completely customizable. This adaptability of the work platform support system 100 provides a convenient way to gain access to virtually any shape work area required in construction.

FIGS. 8A, 8B, and 8C depict various views, and close-up views of the interconnection between a middle support deck joist 52 and the joist 30. The middle support deck joist 52 provides added support to support platforms 50 (see e.g., FIG. 9) and may span between two joists 30. At either end of the middle support deck joist 52 is a pin 53 which communicates with a corresponding hole 54 on the upper portion of the joist 30. For example, FIG. 8B depicts an exploded view of the interconnection, wherein pin 53 will go in hole 54A. In this

manner, movement (both lateral and axial) of the middle support deck joist 52 is minimized.

FIG. 9 shows the embodiment of support system 100 from FIG. 7 wherein a platform 50A has been placed on the support system 100 thus transforming the support system 100 into a work platform system 120. The platform 50A rests, in this embodiment, on the middle support deck joist 52A and on the joists 30A, 30B, 30D. The edges of the platform 50A may rest on the top of the middle support deck joist 52 and the angle iron 39A, 39B on the top of the applicable joists 30A, 30B, 30D. The configuration of the top of the middle support deck joist 52 and the angle iron 39A, 39B is such that vertical and horizontal movement of the platform 50A is avoided. The work platform 50 typically is sized to be a 4"x8' piece of material. The work platform 50A may include a wood panel 51A, for example. Suitable work platform 50 may be made from metal (e.g., steel, aluminum, etc.), wood, plastic, composite, or other suitable materials. Similarly, the work platform 50 may be made of items that are solid, corrugated, grated, smooth, or other suitable configurations. For example, the work platform 50 may be wood sheeting, plywood, roof decking material, metal on a frame, grating, steel sheeting, and the like. Thus, after placing a first work platform 50A on the work platform support system 100, an installer may continue in this manner and place additional multiple work platforms 50A, 50B, such as shown in FIG. 10, so that the entire support system 100 covered with wood platforms 51A, 51B so that a complete work platform system 120 is created.

FIGS. 11A, 11B, and 11C show various close-up views of an additional, optional feature that may be provide as part of a work platform system 120. A deck retainer plate 60 may be placed over the spacing between the multiple work platforms 50. The deck retainer plate 60 may include a plurality of holes 62 so that a plurality of deck retainer bolts 61 may adhere the deck retainer plate 60 to the joist 30. The deck retainer plate 60 is one way in which to adhere work platforms 50 to the support system 100.

As FIGS. 12 and 13 depict, there is virtually no limit as to the size and shape of the support system 100 and work platform system 120 that can be made with the present invention. FIGS. 12 and 13 show top and bottom perspective views, respectively, of one large rectangular embodiment of a support system 100 and work platform system 120.

As stated above, one deficiency of numerous existing work platforms are their inability to be installed in situ and also their inability to be relocated, extended, or removed, while a portion of the work platform is already installed in place. The present invention overcomes this deficiency. That is, the invention allows for a worker, or workers, to add on additional sections of support system 100 while this worker(s) is physically on an existing, installed portion of support system 100. That is the worker(s) can extend, relocate, or remove support system 100 with only the need of hand tools. No mechanical tools, hoists, cranes, or other equipment is required to add to, subtract from, or relocate the support system 100. This advantage, thus, offers savings in labor, time, and equipment.

For as FIGS. 14 through 18 depict the gradual articulation of just one section of work support system 100 into place. This can be readily accomplished by one, or two, workers by simply placing sequentially an additional joist 30D off of an existing hub 10A. Then a "new" hub 10D is connected to the first joist 30D. A second additional joist 30E is connected to the hub 30D. Further, another hub 10E and joist 30F are connected so that the final joist 30F is connected back to an existing hub 10B. In this manner, a worker(s) can install a new section of support system 100 (e.g., made up of "new" hubs 10D, 10E and "new" joists 30D, 30E, 30F) off of an existing

section of support system **100** (e.g., made up of inter alia hubs **10Q**, **10B**, **10C** and joists **30A**, **30B**). The worker(s) can install new, or relocate, sections of support system **100**, while the worker remains on existing sections of work platform **50**. That is, additional lift equipment, machinery is not required to install, relocate, or remove the additional support system **100** sections. Further, the installing worker(s) need not extend beyond the existing installed support system **100** or, they need only extend barely beyond the system **100**. This allows the present invention to be safer than existing systems available, during installation, relocation, tear down, and movement. For example, as shown in FIG. **14**, the installer(s) can be on the existing work platforms **50A**, **50B**, **50C**, **50D** when relocating, or installing, the next section(s) of the invention.

As FIGS. **15** through **17** clearly show via the motion arrows “M”, that by a combination of rotation of the new joists **30D**, **30E**, **30F** and new hubs **10D**, **10E**, that the new section of work support system **100** is able to move and rotate into its final requisite location. That is, the supports system **100** articulates into place. Further, the articulation can be initiated and stopped (and even reversed) by an installer(s) while the installer(s) remains on the pre-existing support system **100**. Although not shown, additional supplemental devices to aid in the articulation (e.g., motors, hand tools, mechanical tools, hydraulics, etc.) can be used.

FIG. **18** shows a new section of support system **100** articulated into place, prior to the installation of support platform(s) **50** and other pieces, as discussed supra (See e.g., FIGS. **8A**, **8B**, **8C**, **9**, **10**, **11A**, **11B**, **11C**, **12**). The removal of a portion of the support system **100** can essentially be done by reversing the aforementioned steps.

Although the present invention, as discussed, may be installed, and extended, via the aforementioned articulation capability, it should be apparent that this method of use is not the only method available. For example, in lieu of articulating the various modules, or sections, of support system **100** from already installed section of support system **100**, the installation may be done, essentially, “in the air”. That is, the system **100** may erected and connected together “in the air”, in a piece-by-piece order via the use of multiple pieces of lifting, or hoisting, equipment. Alternatively, the hubs **10** and joists **30** may be preassembled on the ground, or at a remote location, and then moved and hoisted as a pre-assembled module into the desired location underneath a structure.

With reference to the teachings herein, including at least FIGS. **6A**, **9** and **14-18**, it is apparent that at least one of the joists is to be connected with at least one of the hubs using a pin to provide free rotation of the at least one joist with respect to the at least one hub about the pin. Moreover, it is apparent that the free rotation is restricted by at least one of: i) an additional pin that is to be located proximate a perimeter of the at least one hub; and ii) at least a portion of a work platform when the platform is positioned with respect to the hubs and the joists in the final position.

FIGS. **19A**, **19B**, **19C** **19D** show various embodiments of a joist **30** and hub **10** configuration. For example, FIG. **19D** shows a “standard” length joist **30A** (e.g., 8 foot nominal length) with two hubs **10A**, **10B**. This “standard” length joist **30A** could be termed a “6/6 unit”. FIG. **19C** shows two joists **30A**, **30B** of equal length connected to hubs **10A**, **10B**, **10C**. The joists **30A**, **30B** in FIG. **19C**, being half the length, each of the length of the joist **30A** in FIG. **19D**, may be termed a “3/6 unit” in that they are half the length of the aforementioned “6/6 unit”. Similarly, two unequal length joists **30A**, **30B** are depicted in FIG. **19B**, and can be termed a “2/6 unit” and a “4/6 unit”, respectively. This is because the “2/6 unit” is approximately one third the length of a “standard” “6/6 unit”

joist as shown in FIG. **19D**, as is the “4/6 unit” is approximately two thirds the length of the “6/6 unit”. The same system is shown in FIG. **19A**, wherein the first joist **30A** is termed a “1/6 unit” and the second joist **30B** is termed a “5/6 unit”. As stated above, by using different lengths of joist **30**, and by extending joists **30** from hubs **10** at different angles, one can obtain a nearly infinite variety of configurations and footprints of the support systems **100**. This variety, for example, allows the installer to set up the support system **100** around various obstacles (e.g., columns, piers, abutments, etc.) and structures. The variety allows the installer to create numerous shapes to the work platform system **120** beyond just a rectangle.

FIGS. **20A** and **20B** depict the plan view of just two embodiments of the invention. In these figures it can be seen that the work platform support system **100** is capable of various horizontal alignments. For example, FIG. **20A** shows 8 foot length joists **30** interconnected with a plurality of hubs **10**. Due to spacing between the pin **40** and hub **10**, some flexibility is provided in the system **100** so that the system **100** can be curved, or “racked”, in the horizontal direction. This can help allow the system **100** to be installed around structures. FIG. **20B** depicts a system **100** that is angled. For example, the joists **30C** connected to hub **10C** can be shorter than joists **30B** connected to hub **10B**. Joists **30B**, in turn, are shorter than joists **30A**, which are connected to hub **10A**. In this fashion, by using joists **30A**, **30B**, **30C** of different length and/or altering the angle at which a joist **30** is connected to a hub **10**, systems **100** that are angled, as in FIG. **20B** can be configured. Similarly, this allows the system **100** to be installed, for example, around various impediments, structures, and the like.

FIGS. **21A** through **22C** show various connection details as to how a railing system can be attached to the present invention. FIGS. **21A**, **21B** and **21C** show the interconnection between a railing standard **85** and the hub **10**. The railing standard **85** is typically elongate and includes a first flange **86A**, and a second flange **86B** extending therefrom for connection to the hub **10**. The first flange **86A** has a hole in it, as does the second flange **86B**. By leading the pin **40** through the upper flange **86A**, then through holes **13** in the upper element **11** down through the lower flange **86B**, and then through the holes **14** in the lower element **12** an installer is able to attach the railing standard **85** to the hub **10** of the support system **100**. The pin **40** may include various devices, such as roll pins **42** and a holding loop **43**. In this manner, a plurality of railing standards **85** may be attached to a plurality of hubs **10**, creating a railing system around the work platform system **120** so as to meet the regulations promulgated by OSHA.

FIGS. **22A**, **22B**, **22C** depict various views of a railing standard **85** and its interconnection with a railing **88**. The railing **88** can be a variety of materials, such as chain, cable, line, and the like. For example, the railing **88** may be galvanized aircraft cable. The railing standard **85** includes a plurality of holes **87**. As the exploded view in FIG. **22B** shows, a J-bolt **89** may be used with a nut **84** to attach the railing **88** to the railing standard **85**. By attaching a plurality of railings **88** to the plurality of railing standards **85** a railing system that meets the OSHA regulations is made. For example, an additional railing **88** may be added at the midpoint of the railing standard **85**. In other embodiments, the railing standards **85** can also be used to erect a work enclosure system. For example, tarps, sheeting, or the like could be attached to the railing standards **85** to enclose the work area for painting, demolition, asbestos or lead paint abatement, and similar activities where the workers do not want any escape of fumes, paint, hazardous materials, debris, etc. from the work area.

FIG. 23 shows an elevation sectional view of one embodiment wherein a support system 100 and work platform system 120 are attached, via a suspension connector 80, to a structure 90. The structure 90 in this embodiment is a bridge 90. On the underside of the bridge 90 are a plurality of beams 92. A series of suspension connectors 80, in this embodiment high strength chains, are attached to several of the beams 92 via structure attachment device 82, in this embodiment standard beam clamps. At the perimeter of the work platform system 120 are a plurality of railing standards 85, thereby creating a railing system around the work platform system 120. The plurality of chains 80 are attached to various hubs 10 in the support system 100 thereby providing structural connection to the bridge 90. In this manner, a work platform system 120 and support system 100 can be fully suspended from a suitable structure 90. Note that each hub 10 does not necessarily require a suspension connector 80 to be connected to the structure 90. For example, there is no suspension connector 80 connecting hub 10X to beam 92X. This may be because hub 10A does not line up underneath beam 92X, or other suitable suspension point, and thus, using a chain 80 in that location is either not possible, or not desirable.

The suspension connector 80 may be any suitable support mechanism that can support both the work platform system 120, and all its ancillary dead loads, plus any intended live load that is placed upon the work platform system 120. In fact, the work platform system 120 may support its own weight plus at least four times the intended live load that is to be placed on the work platform system 120. Similarly, the suspension connector 80 is also suitable to support its own weight plus at least four times the intended live load placed on it. The suspension connector 80 may be a high-strength chain, cable, or the like. For example, one suitable suspension connector 80 is $\frac{3}{8}$ " grade 100, heat-treated alloy chain.

The suspension connector 80 is attached to a beam clamp 82 which is further attached to a plurality of elements 92 on the underside of a structure 90. The structure 90 may be a bridge, viaduct, ceiling structure of a building, or the like. Similarly, the elements 92 which the suspension connector 80 are attached to may be beams, joists, or any other suitable structural element of the structure 90. Instead of beam clamps 82, other suitable structure attachment devices 82 may be used.

FIGS. 24A, 24B, 25A, 25B all depict various views of the interconnection between the suspension connector 80 (e.g., chain, cable, etc.) and the hub 10. In the embodiment shown, a free end of the chain 80 (i.e., end distal to structure 90) is placed through the center opening area 19 of the top element 11 of the hub 10. The chain 80 is then slid over and in to one of the four slots 17 (e.g., 17A). Once the chain 80 is placed within slot 17A, a chain retainer pin 200 is placed in the adjacent transverse slot 18A so that the chain 80 kept retained in the distal end of slot 17A. The chain 80 and slot 17A are sized and configured so that upon proper placement of the keeper pin 200 within the transverse slot 18A, the chain 80 is effectively locked to the hub 10 and is unable to slip, vertically or horizontally, from its position in 17A. This locking system effectively fixes the hub 10 to the chain 80. As an added safety check, a zip tie 201 may be placed between a hole 202 in the chain retainer pin 200 and an adjacent link in the chain 80. This further provides a visual aid to the installer to ensure that the chain retainer pin 200 has been installed.

An alternative device for connecting a suspension connector 80 to the work platform support system 100 is an auxiliary suspender mounting bracket 300. The auxiliary mounting bracket 300 is typically used when a particular hub 10 can not be accessed for connection with a suspension connector

80. As the various FIGS. 26A, 26B, 26C, and 26D depict, one embodiment of the auxiliary suspender mounting bracket 300 includes two opposing and parallel flanges 303. Spanning the flanges 303 is an interconnecting tube 304 and a base plate 302. Through the base plate 302 are a plurality of mounting holes 305. The auxiliary suspender mounting bracket 300 can be used in lieu of, or in addition to, the hub 10 for a suspension point. The bracket 300 allows a suspension connector 80 to be connected to the system 100 at locations other than a hub 10.

For example, FIG. 27 depicts a scenario that may typically be encountered when installing a work platform system 120. Note that FIG. 27 is not drawn to scale. One or more obstructions 95A may be located on the underside of the structure 90, or between the structure 90 and the work platform system 120. These obstruction(s) 95A may be man-made, or natural. For example, the obstructions 95A may be concrete beams, box-beams, inadequately sized framework, ductwork, lighting, finished surfaces, and the like. The obstructions 95A are such that a particular hub 10B is not practical, or possible, as a connecting point for the system 120 to a suspension connector 80. In this case, one or more auxiliary suspender mounting brackets 300 may be attached to a joist 30. High strength bolts (not shown) may be passed through the mounting holes 305 and then through holes on an upper element 32 and connected to bolts below the upper element 32. (See for similar connection detail the connection of plate 60 in FIG. 11B). The suspension connector 80 (e.g., chain) may be connected, via a beam clamp 82, to a beam 92 that is on the underside of the structure 90.

As shown in FIG. 27, obstruction 95B is directly vertically over hub 10B, thereby rendering hub 10B inadequate for a suspension point. Thus, a bracket 300 can be attached to a joist 30 adjacent to hub 10B, thereby allowing a suspension connector 80 to get proper attachment to a nearby beam 92. The angle, Φ , between the suspension connector 80 and vertical, denoted by V, allows for the suspension connector 80 to be either non-vertical, or slightly off of vertical.

FIGS. 28A, 28B, and 28C show elevation views of various embodiments wherein the vertical flexibility of the present invention is apparent. For example, FIG. 28A shows a portion of a work platform system 120 suspended from the non-flat underside of a structure 90 (e.g., arched bridge). The suspension connector 80 and other connection details are not shown for ease of illustration. There is flexibility, due to the design, in the interconnections between hub 10 and joist 30. This flexibility allows for some bendability in the vertical direction (See e.g., FIG. 28A). This allows the system 120, for example, to parallel, or "mirror", the underside of a curved, arched bridge.

Alternatively, should the curvature of the supporting structure 90 be even greater, a configuration such as shown in FIG. 28B can be installed. That is multiple portions of the system 120 are not co-planar, but rather stepped, or tiered. If required, various suspension connectors 80 may be installed of such length so that multiple hubs 10A, 10B may be installed to the same suspension connector 80. As discussed above, the suspension connector 80 may be connected to a slot 17 of the upper hub 10A, then passed through the bottom opening 23 of the upper hub 10A and then connected also to a slot 17 of the lower hub 10B (See e.g., FIGS. 24A, 24B).

As FIG. 28C shows another configuration of the present invention is the capability to install the system 120 in a multi-level configuration. For example, where work perhaps needs to be done on a vertical structure 99 (e.g., bridge pier), at least two systems 120A, 120B may be installed. Similar to the connection scenario used in FIG. 28B (above), suspension connector 80 can, again, be of suitable length so as to pass

from hubs 10A on the upper system 120 on to, and also connect up to, the hubs 10B on the lower system 120. In this manner, multiple levels of system 120 may be installed in a vertical orientation.

Load Testing:

The present invention is capable of supporting its own weight and at least four times the intended live load applied, or transmitted, upon the work platform system 120. Various load tests were conducted on the present invention. See e.g., FIG. 26.

For example, one uniform load test was conducted on a 8 foot×8 foot module of a work platform system 120. In this load test, a two (2) 4'×8' sheets of ¾" BB OES PLYFORM decking served as the platform 50. The platform 50 (i.e., Plyform) was installed as discussed above. The work platform system 120 included standard hubs 10, joists 30, supports 52, and the like, as discussed above. One of the two sheets of Plyform was uniformly loaded with a plurality of steel plates. Each plate was ½"×12"×30", and weighed 50 pounds. Twelve (12) plates were arranged per layer on the platform 50. A total of 256 plates were added, producing a total live load of 12,800 pounds, or 400 PSF (i.e., pounds per square foot). Further, the Plyform platform 50 was thoroughly soaked with water while the full weight of the plates on it. The test was witnessed and there was no failure of the Plyform after being loaded for over twenty four hours. In conclusion, by using ¾" BB OES PLYFORM as the platform 50 in the present invention, when supported on all four sides, the work platform system 120 is capable of supporting a uniform load of 100 PSF at a 4:1 safety factor.

Another load test was conducted on the invention. In this second load test, a nominal 8 foot×8 foot module of a work platform system 120 was erected. The four hubs 10 of this module were supported off the floor and secured to resist uplift. Then, two additional 8 foot×8 foot work platform system 120 modules, or "grids", were assembled from one side of the original, supported module. This resulted in a 16 foot cantilever, which simulates a scenario that might be encountered during erection of the work platform system 120. The work platform system 120 included standard hubs 10, joists 30, supports 52, and the like, as discussed above. One extreme corner of the cantilever was loaded with weight to simulate a load on a cantilever. A 1,000 weight with a 30"×30" footprint was placed on the cantilevered corner. Additional 50 pound weights were added, producing a total live load on the corner of 2,200 pounds. The test was witnessed and there was no failure of the work platform system 120 and the maximum deflection at the hub 10 at the loaded corner was 6.5 inches. In conclusion, in a 16 foot cantilever configuration, the present invention is capable of supporting a load of 550 pounds with a 4:1 safety factor.

A third load test that was conducted, and witnessed, on an embodiment of the present invention, entailed the live loading of a 16 foot span with 45 PSF×4 Safety Factor (i.e., 180 PSF). In this test, as depicted in FIG. 29, two joists 30A, 30B and three hubs 10A, 10B, 10C were connected to form a 16 foot span. The span was then lifted via chains 80A, 80B connected to the two outer hubs 10A, 10C. The chains 80A, 80B were connected, in turn, to cables, hydraulic cylinders, and fixed framing 500. As FIG. 29 indicates weight (i.e., 22,835 pounds), simulating an intended live load plus a factor of safety of four, were suspended along lengths of the joists 30A, 30B. Strips of plywood approximately 1 foot wide were clamped to either side of the joists 30A, 30B in to simulate a portion of the platform 50. The structure (i.e., hubs 10, joists

30) was suspended with the aforementioned weight without failure. The test was repeated a second time, resulting in no failure.

A fourth load test conducted, and witnessed, on a portion of the present invention entailed a chain load test. In this test, a chain 80 was attached to a hub 10. The chain 80, which was a Grade 100 chain, was connected to one of the slots 17 of the hub 10, similar to the methods discussed above. The chain 80 and hub 10 assembly then was setup on a hydraulic test stand wherein a 30.6 Kip load was applied to the chain 80. There was no failure of either the hub 10 or chain 80. In conclusion, a typical hub 10 and chain 80 can withstand at least a 7.4 Kip load with a 4:1 factor of safety.

Thus, depending on spacing of the suspension connectors 80 that attach to the work platform system 120, various loading capabilities are created with the present invention. If the suspension connectors 80 are spaced in a 8 foot×8 foot grid configuration, the system 120 can be termed a heavy duty support system that can support 75 PSF. If the suspension connectors 80 are spaced at a 8 foot×16 foot grid, the system 120 can be termed a medium duty support system that can support 50 PSF. Similarly, if the suspension connectors 80 are spaced at 16 foot×16 foot grid, the system 120 can be termed a light duty support system that can support 25 PSF.

The foregoing description of the present invention has been presented for purposes of illustration and description. It is not intended to be exhaustive or to limit the invention to the precise form disclosed or to the materials in which the form may be embodied, and many modifications and variations are possible in light of the above teaching.

What is claimed is:

1. An interconnection structure comprising:

an element, an additional element and a section situated therebetween connecting the element and the additional element,

the element having a centralized element opening disposed generally at or about a center of the element, and a slot extending from the centralized element opening to a distal end, the slot configured to receive and retain a suspension connector therein, at or near the distal end of the slot; and

the section connecting the element and the additional element having a substantially uniform cross-section along a length thereof.

2. The interconnection structure of claim 1, wherein the element comprises a surface that is substantially planar.

3. The interconnection structure of claim 2, wherein the additional element comprises a surface that is substantially planar.

4. The interconnection structure of claim 3, wherein the element comprises a surface that is substantially planar and the additional element comprises a surface that is substantially planar and the respective surfaces are substantially parallel to each other.

5. The interconnection structure of claim 1 wherein the element and the additional element are positioned at distal ends of the section.

6. The interconnection structure of claim 1, wherein the opening is at least one of generally cruciform in shape so as to be configured to receive the suspension connector.

7. An interconnection structure comprising:

an element, an additional element and a section situated therebetween connecting the element and the additional element,

the element having a centralized element opening disposed generally at or about a center of the element, and a slot extending from the centralized element opening to a

15

distal end, the slot configured to receive and retain a suspension connector therein, at or near the distal end of the slot; wherein the element comprises a surface that is substantially planar and octagonal and the additional element includes a surface that is substantially planar and octagonal and the respective surfaces are substantially parallel.

8. An interconnection structure comprising: an element, an additional element and a section situated therebetween connecting the element and the additional element,

the element having a centralized element opening disposed generally at or about a center of the element, and a slot extending from the centralized element opening to a distal end, the slot configured to receive and retain a suspension connector therein, at or near the distal end of the slot; wherein the section connected between the element and the additional element is a cylindrical section.

9. The interconnection structure of claim **8**, wherein a longitudinal axis of the cylindrical section is normal to the at least a surface of the element and at least a surface of the second element.

10. An interconnection structure comprising: an element, an additional element and a section situated therebetween connecting the element and the additional element,

the element having a centralized element opening disposed generally at or about a center of the element, and a slot extending from the centralized element opening to a distal end, the slot configured to receive and retain a suspension connector therein, at or near the distal end of the slot; wherein an elongate structural member is configured to be interconnected by way of at least one respective pair of coaxial openings to provide for articulation of the at least one elongate structural member, and the section connecting the element and the additional element being substantially cylindrical and having a substantially uniform cross-section along a length thereof.

11. An interconnection structure further comprising: an element, an additional element and a section situated therebetween connecting the element and the additional element,

the element having a centralized element opening disposed generally at or about a center of the element, and a slot extending from the centralized element opening to a distal end, the slot configured to receive and retain a suspension connector therein, at or near the distal end of the slot;

a reinforcing plate positioned adjacent the element and an additional reinforcing plate positioned adjacent the additional element; and

a plurality of gussets connected to at least one of the reinforcing plate, the additional reinforcing plate and the section connected to and between the element and the additional element.

12. An interconnection structure comprising: an element, an additional element and a section situated therebetween connecting the element and the additional element,

the element having a centralized element opening disposed generally at or about a center of the element, and a slot extending from the centralized element opening to a distal end, the slot configured to receive and retain a suspension connector therein, at or near the distal end of the slot;

wherein the section connected to and between the element and the additional element is a cylindrical section, the element comprises a surface that is substantially planar

16

and octagonal and the additional element includes a surface that is substantially planar and octagonal, wherein the respective surfaces are substantially parallel, and wherein there are eight pairs of respective, coaxial openings symmetrically spaced about a central longitudinal axis passing through the cylindrical section.

13. The interconnection structure of claim **12**, further comprising at least one of a reinforcing plate positioned adjacent the element and an additional reinforcing plate positioned adjacent the additional element, and a plurality of gussets are connected to the at least one of the reinforcing plate, the additional reinforcing plate and the section connected to and between the element and the additional element.

14. An interconnection structure comprising: an element, an additional element and a section situated therebetween connecting the element and the additional element,

the element having a centralized element opening disposed generally at or about a center of the element, and a slot extending from the centralized element opening to a distal end, the slot configured to receive and retain a suspension connector therein, at or near the distal end of the slot; wherein:

the section connected to and between the element and the additional element is a cylindrical section;

the element comprises a surface that is substantially planar and octagonal;

the additional element includes a surface that is substantially planar and octagonal;

the respective element and additional element surfaces are substantially parallel; and

the element and the additional element each include a plurality of openings symmetrically spaced about a central longitudinal axis passing through the cylindrical section such that respective pairs of the openings are coaxial.

15. The interconnection structure of claim **14**, comprising eight respective pairs of coaxial openings.

16. A method of using an interconnection structure, the method comprising:

providing an interconnection structure comprising: an element, an additional element and a section situated therebetween connecting the element and the additional element, the element having a centralized element opening disposed generally at or about a center of the element, and a slot extending from the centralized element opening to a distal end, the slot configured to receive and retain a suspension connector therein, at or near the distal end of the slot, and the section connecting the element and the additional element having substantially uniform cross-section along a length thereof;

receiving a suspension connector in the slot; and retaining the connector, at or near the distal end of the slot.

17. The method of claim **16**, further comprising sliding a free end of the connector into the slot.

18. The method of claim **17**, wherein the retaining includes retaining the free end of the connector at or near the distal end of the slot.

19. An interconnection structure in combination with an auxiliary mounting bracket, the combination comprising:

an interconnection structure for interconnection with an elongate structural member, the interconnection structure comprising:

an element having a plurality of openings;

an additional element having a plurality of openings located so that at least a respective one of the plurality

17

of the openings of the element is coaxial with at least a respective one of the plurality of openings of the additional element to create at least one respective pair of coaxial openings; and
 a section connected between the element and the additional element, the section being substantially cylindrical and having a substantially uniform cross-section along a length thereof; and
 an auxiliary suspender mounting bracket configured for connection with a suspension connector for suspension from another structure.

20. The combination of claim **19**, wherein the auxiliary suspender mounting bracket includes two opposing and parallel flanges, an interconnecting tube and a base plate, wherein the interconnecting tube and base plate span the flanges, and a plurality of mounting holes in the base plate.

21. A work platform support structure comprising:

a first interconnection structure connectable in fixed relation to a second interconnection structure using a first elongate structural member;

a third interconnection structure connectable to a fourth interconnection structure using a second elongate structural member, the third and the fourth interconnection structures further connectable to the first and the second interconnection structures using third and fourth elongate structural members;

wherein, when connected, the second, the third and the fourth elongate structural members, and the third and the fourth interconnection structures articulate with respect to the first and second interconnection structures and the first elongate structural member to an extended or final position;

wherein at least one of the elongate members is connectable with at least one of the interconnection structures using a pin to provide free rotation of the at least one elongate member with respect to the at least one interconnection structure about the pin;

wherein the free rotation is restricted by at least one of: i) an additional pin that is to be located proximate a perimeter of the at least one interconnection structure; and ii) at least a portion of a work platform when the platform is positioned with respect to the interconnection structures and the elongate members in the extended or final position; and

wherein each interconnection structure includes: an element, an additional element and a section situated therebetween connecting the element and the additional element, the element having a centralized element opening disposed generally at or about a center of the element, and a slot extending from the centralized element opening to a distal end, the slot configured to receive and retain a suspension connector therein, at or near the distal end of the slot.

22. The structure of claim **21**, wherein the interconnection structures and the elongate structural members are interconnected.

23. The system of claim **22**, wherein the interconnection is via a plurality of coaxial openings in the interconnection structures.

24. An interconnection structure comprising:

an element, an additional element and a section situated therebetween connecting the element and the additional element,

the element having a centralized element opening disposed generally at or about a center of the element, and a slot extending from the centralized element opening to a

18

distal end, the slot configured to receive and retain a suspension connector therein, at or near the distal end of the slot; and

the section connecting the element and the additional element being substantially cylindrical and having a substantially uniform cross-section along a length thereof; wherein: the element comprises a surface that is substantially planar; the additional element includes a surface that is substantially planar; and the element and the additional element each include a plurality of spaced apart openings such that at least one of the plurality of openings in the element is coaxial with at least one of the plurality of openings in the additional element.

25. The interconnection structure of claim **24**, wherein the at least one respective pair of coaxial openings is structured to receive and to provide for articulation of an elongate structural member.

26. A work platform support structure comprising:

a first interconnection structure connected in fixed relation to a second interconnection structure using a first elongate structural member, the first interconnection structure comprising an element, an additional element and a section situated therebetween connecting the element and the additional element, the element having a centralized element opening disposed generally at or about a center of the element, and a slot extending from the centralized element opening to a distal end, the slot configured to receive and retain a suspension connector therein at or near the distal end of the slot, and the section having a substantially uniform cross-section along a length thereof;

a second elongate structural member connectable to the first interconnection structure, wherein, when connected, the second elongate structural member is pivotable relative to the first elongate structural member from a first position to an extended or final position;

a third elongate structural member connectable to the second interconnection structure, wherein, when connected, the third elongate structural member is pivotable relative to the first elongate structural member from a first position to an extended or final position;

wherein at least one of the elongate structural members is connectable with at least one of the interconnection structures using a pin; and

wherein the pivoting of at least one of the second or third elongate structural members is restricted by at least one of: i) an additional pin that is to be located proximate a perimeter of the corresponding interconnection structure; and ii) at least a portion of a work platform when the work platform is positioned with respect to the interconnection structures and the elongate members in the extended or final position.

27. The work platform support structure of claim **26**, wherein the pivoting is restricted by the at least a portion of a work platform when the work platform is positioned with respect to the interconnection structures and the elongate members in the extended or final position.

28. The work platform support structure of claim **26**, wherein the pivoting is restricted by an additional pin that is to be located proximate a perimeter of the corresponding interconnection structure.

29. The work platform support structure of claim **26**, further comprising a third interconnection structure connectable to at least one of the second elongate structural member and the third elongate structural member.

30. The work platform support structure of claim 29, wherein the third interconnection structure is connectable to both the second elongate structural member and the third elongate structural member.

31. The work platform support structure of claim 26, further comprising a third interconnection structure connectable to the second elongate structural member.

32. The work platform support structure of claim 31, further comprising a fourth interconnection structure connectable to the third elongate structural member.

33. The work platform support structure of claim 32, wherein, when connected, the third interconnection structure pivots relative to at least a portion of the second elongate structural member.

34. The work platform support structure of claim 33, wherein, when connected, the fourth interconnection structure pivots relative to at least a portion of the third elongate structural member.

35. The work platform support structure of claim 34, further comprising a fourth elongate structural member connectable to at least one of the third interconnection structure and fourth interconnection structure.

36. The work platform support structure of claim 35, wherein the fourth elongate structural member is connectable to both of the third interconnection structure and fourth interconnection structure.

37. The work platform support structure of claim 26, wherein the second and third elongate structural members are substantially perpendicular to the first elongate structural member when in the extended or final position.

38. The work platform support structure of claim 37, wherein the second and third elongate structural members are substantially parallel with the first elongate structural member when in the first position.

39. A method of installing an additional work platform system module with respect to a first work platform system module, the method comprising:

providing a first work platform system module comprising a first work platform support system module having a first interconnection structure, a second interconnection structure, an elongate structural member connected to and in operable association with the first and second interconnection structures, and a first work platform supported by the support system module;

providing a first additional elongate structural member and a second additional elongate structural member;

connecting the first additional elongate structural member to the first interconnection structure;

articulating the first additional elongate structural member with respect to the first work platform support system module from a first position to an extended position;

connecting the second additional elongate structural member to the second interconnection structure; and

articulating the second additional elongate structural member with respect to the first work platform support system module from a first position to an extended position,

wherein the first and second interconnection structures comprise an element, an additional element and a section situated therebetween connecting the element and the additional element, the element having a centralized element opening disposed generally at or about a center of the element, and a slot extending from the centralized element opening to a distal end, the slot configured to receive and retain a suspension connector therein, at or near the distal end of the slot and the section having a uniform cross-section along a length thereof.

40. The method of claim 39, wherein the articulating of at least one of the first additional elongate structural member and second additional elongate structural member is completed in a cantilevered manner.

41. The method of claim 39, further comprising providing a first additional interconnection structure.

42. The method of claim 41, further comprising connecting the first additional interconnection structure to the first additional elongate structural member.

43. The method of claim 42, wherein the connecting the first additional interconnection structure to the first additional elongate structural member occurs before the articulating of the first additional elongate structural member.

44. The method of claim 42, wherein the connecting the first additional interconnection structure to the first additional elongate structural member occurs after the articulating of the first additional elongate structural member.

45. The method of claim 42, further comprising providing a second additional interconnection structure.

46. The method of claim 45, further comprising connecting the second additional interconnection structure to the second additional elongate structural member.

47. The method of claim 46, wherein the connecting the second additional interconnection structure to the second additional elongate structural member occurs before the articulating of the second additional elongate structural member.

48. The method of claim 46, wherein the connecting the second additional interconnection structure to the second additional elongate structural member occurs after the articulating of the second additional elongate structural member.

49. The method of claim 46, further comprising providing a third additional elongate structural member.

50. The method of claim 49, further comprising connecting the third additional elongate structural member to the first and second additional interconnection structures.

51. The method of claim 39, further comprising providing an additional pair of interconnection structures.

52. The method of claim 51, further comprising connecting the additional pair of interconnection structures to the first and second elongate structural members.

53. The method of claim 52, wherein the articulating the first elongate structural member and the articulating the second elongate structural member includes articulating the additional pair of interconnection structures.

54. The method of claim 52, wherein the connecting the additional pair of interconnection structures to the first and second elongate structural members includes using a pin such that at least one of the additional pair of interconnection structures is freely rotatable about the pin.

55. The method of claim 39, wherein at least one of the connecting the first elongate structural member to the first interconnection structure and the connecting the second elongate structural member to the second interconnection structure include using a pin such that the first or second elongate structural member is freely rotatable relative to the elongate structural member.

56. The method of claim 39, wherein at least one of the articulating the first elongate structural member and the articulating the second elongate structural member includes translating at least one of the first or second elongate structural members.

57. The method of claim 39, wherein the connecting the first additional elongate structural member to the first interconnection structure and connecting the second additional elongate structural member to the second interconnection structure occur before the articulating the first additional

21

elongate structural member with respect to the first work platform support system module from a first position to an extended position and the articulating the second additional elongate structural member with respect to the first work platform support system module from a first position to an extended position.

58. The method of claim **57**, wherein the first and second additional elongate structural members are substantially perpendicular to the elongate structural member in the extended position.

59. The method of claim **58**, wherein the first and second additional elongate structural members are substantially parallel with the elongate structural member in the first position.

60. The method of claim **39**, wherein the articulating the first additional elongate structural member with respect to the first work platform support system module from a first position to an extended position occurs before the connecting the second additional elongate structural member to the second interconnection structure.

22

61. The method of claim **39**, further comprising securing at least one of the first additional elongate structural member or second additional elongate structural member in the extended position by at least one of: i) a pin that is to be located proximate a perimeter of the corresponding interconnection structure; and ii) at least a portion of a work platform when the work platform is positioned with respect to the additional elongate structural members in the extended position.

62. The method of claim **61**, wherein at least one of the first and second additional elongate structural members is secured in the extended position by a pin that is to be located proximate a perimeter of the corresponding interconnections structure.

63. The method of claim **61**, wherein at least one of the first and second additional elongate structural members is secured in the extended position by at least a portion of a work platform when the work platform is positioned with respect to the additional elongate structural members in the extended position.

* * * * *