

US009095337B2

(12) **United States Patent**
Euteneuer et al.

(10) **Patent No.:** **US 9,095,337 B2**
(45) **Date of Patent:** **Aug. 4, 2015**

(54) **METHODS AND APPARATUS FOR DELIVERING STAPLES TO A TARGET TISSUE**

(71) Applicant: **Rotation Medical, Inc.**, Plymouth, MN (US)

(72) Inventors: **Charles L. Euteneuer**, St. Michael, MN (US); **Rebecca McCarville**, Spring Park, MN (US); **Duane Frion**, Brooklyn Center, MN (US); **Nathaniel Zenz-Olson**, Blaine, MN (US); **Diane M. Feehan**, Corcoran, MN (US)

(73) Assignee: **Rotation Medical, Inc.**, Plymouth, MN (US)

(*) Notice: Subject to any disclaimer, the term of this patent is extended or adjusted under 35 U.S.C. 154(b) by 167 days.

(21) Appl. No.: **13/889,687**

(22) Filed: **May 8, 2013**

(65) **Prior Publication Data**

US 2013/0245683 A1 Sep. 19, 2013

Related U.S. Application Data

(63) Continuation of application No. 12/794,551, filed on Jun. 4, 2010, now Pat. No. 8,821,536.

(60) Provisional application No. 61/184,198, filed on Jun. 4, 2009, provisional application No. 61/253,800, filed on Oct. 21, 2009, provisional application No. 61/313,051, filed on Mar. 11, 2010.

(51) **Int. Cl.**
A61B 17/064 (2006.01)
A61B 17/068 (2006.01)
(Continued)

(52) **U.S. Cl.**
CPC **A61B 17/0642** (2013.01); **A61B 17/0644** (2013.01); **A61B 17/0682** (2013.01); **A61F 2/0063** (2013.01); **A61F 2/08** (2013.01); **A61B 17/0491** (2013.01); **A61B 17/0643** (2013.01)

(58) **Field of Classification Search**

CPC **A61B 17/068**; **A61B 17/0682**; **A61B 17/0642**; **A61B 2017/0645**; **A61B 17/064**; **A61B 17/0644**; **A61B 17/0643**
USPC **606/75**, **142**, **143**, **151**, **219**, **220**, **304**, **606/323**; **227/67**, **68**, **71**

See application file for complete search history.

(56) **References Cited**

U.S. PATENT DOCUMENTS
511,238 A 12/1893 Hieatzman et al.
765,793 A 7/1904 Ruckel

(Continued)

FOREIGN PATENT DOCUMENTS

CA 2390508 A1 5/2001
EP 0142225 A1 5/1985

(Continued)

OTHER PUBLICATIONS

Alexander et al.; Ligament and tendon repair with an absorbable polymer-coated carbon fiber stent; Bulletin of the Hospital for Joint Diseases Orthopaedic Institute; vol. 46; No. 2; pp. 155-173; Fall 1986.

(Continued)

Primary Examiner — Thomas McEvoy

(74) *Attorney, Agent, or Firm* — Seager, Tufte & Wickhem LLC

(57) **ABSTRACT**

A device for attaching a sheet-like implant to a target tissue includes a pilot member and a staple push rod. In some embodiments, the pilot member has a distal end and at least a pair of prongs extending from the distal end. The prongs are configured to form pilot holes when the distal end of the pilot member is pressed against the target tissue. The staple push rod is disposed within at least a portion of the pilot member and slidable relative thereto. The staple push rod includes at least a pair of stakes. Each stake is dimensioned to engage a surface of a staple to apply pushing forces thereto. Each stake is positioned relative to a prong along an inner surface of the pilot member so that the stakes advance into the pilot holes when the stakes are moved in a distal direction. Methods for attaching a sheet-like implant to a target tissue are also disclosed

18 Claims, 16 Drawing Sheets

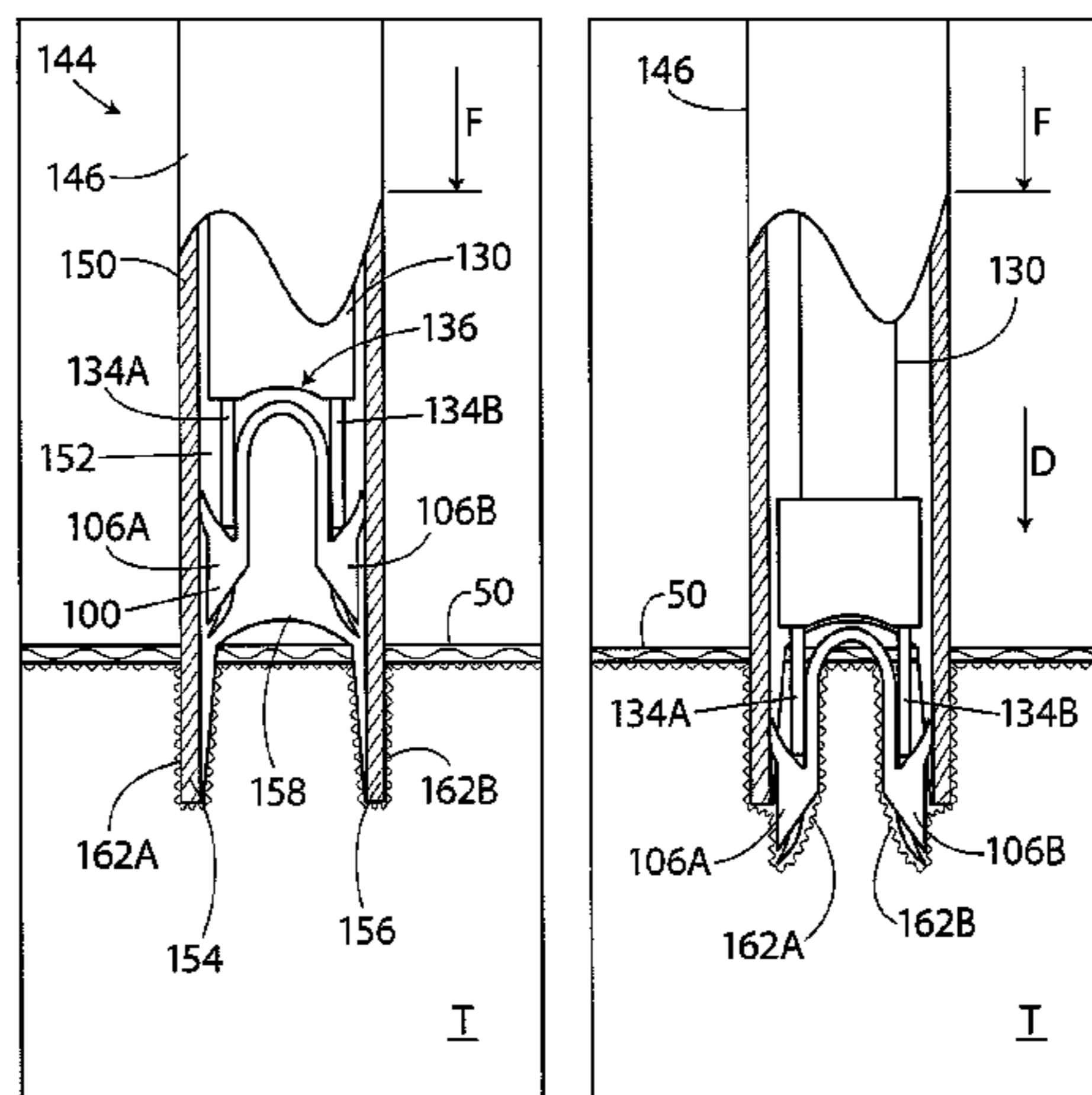

(51)	Int. Cl.		4,738,255 A	4/1988	Goble et al.
	<i>A61F 2/00</i>	(2006.01)	4,741,330 A	5/1988	Hayhurst
	<i>A61F 2/08</i>	(2006.01)	4,762,260 A	8/1988	Richards et al.
	<i>A61B 17/04</i>	(2006.01)	4,799,495 A	1/1989	Hawkins et al.
			4,809,695 A	3/1989	Gwathmey et al.
			4,851,005 A	7/1989	Hunt et al.
			4,858,608 A	8/1989	McQuilkin
(56)	References Cited		4,884,572 A	12/1989	Bays et al.
	U.S. PATENT DOCUMENTS		4,887,601 A	12/1989	Richards
			4,924,866 A	5/1990	Yoon
			4,930,674 A	6/1990	Barak
	1,728,316 A	9/1929 von Wachenfeldt et al.	4,968,315 A	11/1990	Gattorna
	1,855,546 A	4/1932 File	4,976,715 A	12/1990	Bays et al.
	1,868,100 A	7/1932 Goodstein	4,994,073 A	2/1991	Green
	1,910,688 A	5/1933 Goodstein	4,997,436 A	3/1991	Oberlander
	1,940,351 A	12/1933 Howard	5,002,563 A	3/1991	Pyka et al.
	2,034,785 A	3/1936 Wappler	5,013,316 A	5/1991	Goble et al.
	2,075,508 A	3/1937 Davidson	5,015,249 A	5/1991	Nakao et al.
	2,131,321 A	9/1938 Hart	5,037,422 A	8/1991	Hayhurst et al.
	2,158,242 A	5/1939 Maynard	5,041,129 A	8/1991	Hayhurst et al.
	2,199,025 A	4/1940 Conn	5,046,513 A	9/1991	Gattorna et al.
	2,201,610 A	5/1940 Dawson, Jr.	5,053,047 A	10/1991	Yoon
	2,254,620 A	9/1941 Miller	5,059,206 A	10/1991	Winters
	2,277,931 A	3/1942 Moe	5,062,563 A	11/1991	Green et al.
	2,283,814 A	5/1942 La Place	5,100,417 A	3/1992	Cerier et al.
	2,316,297 A	4/1943 Southerland et al.	5,102,421 A	4/1992	Anspach, Jr.
	2,421,193 A	5/1947 Gardner	5,116,357 A	5/1992	Eberbach
	2,571,813 A	10/1951 Austin	5,122,155 A	6/1992	Eberbach
	2,630,316 A	3/1953 Foster	5,123,913 A	6/1992	Wilk et al.
	2,684,070 A	7/1954 Kelsey	RE34,021 E	8/1992	Mueller et al.
	2,744,251 A	5/1956 Vollmer	5,141,515 A	8/1992	Eberbach
	2,790,341 A	4/1957 Keep et al.	5,141,520 A	8/1992	Goble et al.
	2,817,339 A	12/1957 Sullivan	5,156,609 A	10/1992	Nakao et al.
	2,825,162 A	3/1958 Flood	5,156,616 A	10/1992	Meadows et al.
	2,881,762 A	4/1959 Lowrie	5,167,665 A	12/1992	McKinney
	2,910,067 A	10/1959 White	5,171,259 A	12/1992	Inoue
	3,068,870 A	12/1962 Levin	5,174,295 A	12/1992	Christian et al.
	3,077,812 A	2/1963 Dietrich	5,174,487 A	12/1992	Rothfuss et al.
	3,103,666 A	9/1963 Bone	5,176,682 A	1/1993	Chow
	3,123,077 A	3/1964 Alcamo	5,176,692 A	1/1993	Wilk et al.
	3,209,754 A	10/1965 Brown	5,203,787 A	4/1993	Noblitt et al.
	3,221,746 A	12/1965 Noble	5,217,472 A	6/1993	Green et al.
	3,470,834 A	10/1969 Bone	5,224,946 A	7/1993	Hayhurst et al.
	3,527,223 A	9/1970 Shein	5,242,457 A	9/1993	Akopov et al.
	3,570,497 A	3/1971 Lemole	5,246,441 A	9/1993	Ross et al.
	3,577,837 A	5/1971 Bader, Jr.	5,251,642 A	10/1993	Handlos
	3,579,831 A	5/1971 Stevens et al.	5,261,914 A	11/1993	Warren
	3,643,851 A	2/1972 Green et al.	5,269,753 A	12/1993	Wilk
	3,687,138 A	8/1972 Jarvik	5,269,783 A	12/1993	Sander
	3,716,058 A	2/1973 Tanner, Jr.	5,282,829 A	2/1994	Hermes
	3,717,294 A	2/1973 Green	5,289,963 A	3/1994	McGarry et al.
	3,757,629 A	9/1973 Schneider	5,290,217 A	3/1994	Campos
	3,777,538 A	12/1973 Weatherly et al.	5,304,187 A	4/1994	Green et al.
	3,837,555 A	9/1974 Green	5,333,624 A	8/1994	Tovey
	3,845,772 A	11/1974 Smith	5,342,396 A	8/1994	Cook
	3,875,648 A	4/1975 Bone	5,350,400 A	9/1994	Esposito et al.
	3,960,147 A	6/1976 Murray	5,352,229 A	10/1994	Goble et al.
	3,976,079 A	8/1976 Samuels et al.	5,354,292 A	10/1994	Braeuer et al.
	4,014,492 A	3/1977 Rothfuss	5,364,408 A	11/1994	Gordon
	4,127,227 A	11/1978 Green	5,366,460 A	11/1994	Eberbach
	4,259,959 A	4/1981 Walker	5,370,650 A	12/1994	Tovey et al.
	4,263,903 A	4/1981 Griggs	5,372,604 A	12/1994	Trott
	4,265,226 A	5/1981 Cassimally	5,380,334 A	1/1995	Torrie et al.
	4,317,451 A	3/1982 Cerwin et al.	5,383,477 A	1/1995	Dematteis
	4,400,833 A	8/1983 Kurland	5,397,332 A	3/1995	Kammerer et al.
	4,422,567 A	12/1983 Haynes	5,403,326 A	4/1995	Harrison et al.
	4,454,875 A	6/1984 Pratt et al.	5,405,360 A	4/1995	Tovey
	4,480,641 A	11/1984 Failla et al.	5,411,522 A	5/1995	Trott
	4,485,816 A	12/1984 Krumme	5,411,523 A	5/1995	Goble
	4,526,174 A	7/1985 Froehlich	5,417,691 A	5/1995	Hayhurst
	4,549,545 A	10/1985 Levy	5,417,712 A	5/1995	Whittaker et al.
	4,570,623 A	2/1986 Ellison et al.	5,425,490 A	6/1995	Goble et al.
	4,595,007 A	6/1986 Mericle	5,441,502 A	8/1995	Bartlett
	4,624,254 A	11/1986 McGarry et al.	5,441,508 A	8/1995	Gazielly et al.
	4,627,437 A	12/1986 Bedi et al.	5,456,720 A	10/1995	Schultz et al.
	4,632,100 A	12/1986 Somers et al.	5,464,403 A	11/1995	Kieturakis et al.
	4,635,637 A	1/1987 Schreiber	5,478,354 A	12/1995	Tovey et al.
	4,669,473 A	6/1987 Richards et al.	5,486,197 A	1/1996	Le et al.
	4,696,300 A	9/1987 Anderson	5,497,933 A	3/1996	DeFonzo et al.
	4,719,917 A	1/1988 Barrows et al.			

(56)

References Cited

U.S. PATENT DOCUMENTS

5,500,000	A	3/1996	Feagin et al.	6,506,190	B1	1/2003	Walshe
5,501,695	A	3/1996	Anspach, Jr. et al.	6,511,499	B2	1/2003	Schmieding et al.
5,503,623	A	4/1996	Tilton, Jr.	6,517,564	B1	2/2003	Grafton et al.
5,505,735	A	4/1996	Li	6,524,316	B1	2/2003	Nicholson et al.
5,507,754	A	4/1996	Green et al.	6,527,795	B1	3/2003	Lizardi
5,520,700	A	5/1996	Beyar et al.	6,530,933	B1	3/2003	Yeung et al.
5,522,817	A	6/1996	Sander et al.	6,540,769	B1	4/2003	Miller, III
5,545,180	A	8/1996	Le et al.	6,551,333	B2	4/2003	Kuhns et al.
5,560,532	A	10/1996	Defonzo et al.	6,554,852	B1	4/2003	Oberlander
5,562,689	A	10/1996	Green et al.	6,569,186	B1	5/2003	Winters et al.
5,569,306	A	10/1996	Thal	6,575,976	B2	6/2003	Grafton
5,582,616	A	12/1996	Bolduc et al.	6,599,289	B1	7/2003	Bojarski et al.
5,584,835	A	12/1996	Greenfield	6,620,185	B1	9/2003	Harvie et al.
5,618,314	A	4/1997	Harwin et al.	6,629,988	B2	10/2003	Weadock
5,622,257	A	4/1997	Deschenes et al.	6,638,297	B1	10/2003	Huitema
5,628,751	A	5/1997	Sander et al.	6,648,893	B2	11/2003	Dudasik
5,643,319	A	7/1997	Green et al.	6,666,872	B2	12/2003	Barreiro et al.
5,643,321	A	7/1997	McDevitt	6,673,094	B1	1/2004	McDevitt et al.
5,647,874	A	7/1997	Hayhurst	6,685,728	B2	2/2004	Sinnott et al.
5,649,963	A	7/1997	McDevitt	6,692,506	B1	2/2004	Ory et al.
5,662,683	A	9/1997	Kay	6,723,099	B1	4/2004	Goshert
5,667,513	A	9/1997	Torrie et al.	6,726,704	B1	4/2004	Loshakove et al.
5,674,245	A	10/1997	Ilgen	6,726,705	B2	4/2004	Peterson et al.
5,681,342	A	10/1997	Benchetrit	6,740,100	B2	5/2004	Demopoulos et al.
5,702,215	A	12/1997	Li	6,746,472	B2	6/2004	Frazier et al.
5,713,903	A	2/1998	Sander et al.	6,764,500	B1	7/2004	Van De Moer et al.
5,720,753	A	2/1998	Sander et al.	6,770,073	B2	8/2004	McDevitt et al.
5,725,541	A	3/1998	Anspach, III et al.	6,779,701	B2	8/2004	Bailly et al.
5,741,282	A	4/1998	Anspach, III et al.	6,800,081	B2	10/2004	Parodi
5,766,246	A	6/1998	Mulhauser et al.	6,835,206	B2	12/2004	Jackson
5,782,864	A	7/1998	Lizardi	6,849,078	B2	2/2005	Durgin et al.
5,797,909	A	8/1998	Michelson	6,887,259	B2	5/2005	Lizardi
5,797,931	A	8/1998	Bito et al.	6,926,723	B1	8/2005	Mulhauser et al.
5,797,963	A	8/1998	McDevitt	6,932,834	B2	8/2005	Lizardi et al.
5,807,403	A	9/1998	Beyar et al.	6,939,365	B1	9/2005	Fogarty et al.
5,830,221	A	11/1998	Stein et al.	6,946,003	B1	9/2005	Wolowacz et al.
5,836,961	A	11/1998	Kieturakis et al.	6,949,117	B2	9/2005	Gambale et al.
5,868,762	A	2/1999	Cragg et al.	6,964,685	B2	11/2005	Murray et al.
5,873,891	A	2/1999	Sohn	6,966,916	B2	11/2005	Kumar
5,885,258	A	3/1999	Sachdeva et al.	6,972,027	B2	12/2005	Fallin et al.
5,885,294	A	3/1999	Pedlick et al.	6,984,241	B2	1/2006	Lubbers et al.
5,893,856	A	4/1999	Jacob et al.	6,991,597	B2	1/2006	Gellman et al.
5,904,696	A	5/1999	Rosenman	7,008,435	B2	3/2006	Cummins
5,919,184	A	7/1999	Tilton, Jr.	7,021,316	B2	4/2006	Leiboff
5,922,026	A	7/1999	Chin	7,025,772	B2	4/2006	Gellman et al.
5,928,244	A	7/1999	Tovey et al.	7,033,379	B2	4/2006	Peterson
5,948,000	A	9/1999	Larsen et al.	7,037,324	B2	5/2006	Martinek
5,957,939	A	9/1999	Heaven et al.	7,048,171	B2	5/2006	Thornton et al.
5,957,953	A	9/1999	Dipoto et al.	7,063,711	B1	6/2006	Loshakove et al.
5,968,044	A	10/1999	Nicholson et al.	7,083,638	B2	8/2006	Foerster
5,980,557	A	11/1999	Iserin et al.	7,087,064	B1	8/2006	Hyde
5,989,265	A	11/1999	Bouquet De La Jolinierie et al.	7,112,214	B2	9/2006	Peterson et al.
5,997,552	A	12/1999	Person et al.	7,118,581	B2	10/2006	Fridén
6,063,088	A	5/2000	Winslow	7,144,413	B2	12/2006	Wilford et al.
6,156,045	A	12/2000	Ulbrich et al.	7,144,414	B2	12/2006	Harvie et al.
6,179,840	B1	1/2001	Bowman	7,150,750	B2	12/2006	Damarati
6,193,731	B1	2/2001	Oppelt et al.	7,153,314	B2	12/2006	Laufer et al.
6,193,733	B1	2/2001	Adams	7,160,314	B2	1/2007	Sgro et al.
6,245,072	B1	6/2001	Zdeblick et al.	7,160,326	B2	1/2007	Ball
6,302,885	B1	10/2001	Essiger	7,163,551	B2	1/2007	Anthony et al.
6,312,442	B1	11/2001	Kieturakis et al.	7,163,563	B2	1/2007	Schwartz et al.
6,315,789	B1	11/2001	Cragg	7,169,157	B2	1/2007	Kayan
6,318,616	B1	11/2001	Pasqualucci et al.	7,189,251	B2	3/2007	Kay
6,322,563	B1	11/2001	Cummings et al.	7,201,754	B2	4/2007	Stewart et al.
6,325,805	B1	12/2001	Ogilvie et al.	7,214,232	B2	5/2007	Bowman et al.
6,387,113	B1	5/2002	Hawkins et al.	7,226,469	B2	6/2007	Benavitz et al.
6,391,333	B1	5/2002	Li et al.	7,229,452	B2	6/2007	Kayan
6,413,274	B1	7/2002	Pedros	7,247,164	B1	7/2007	Ritchart et al.
6,425,900	B1	7/2002	Knodel et al.	7,303,577	B1	12/2007	Dean
6,436,110	B2	8/2002	Bowman et al.	7,309,337	B2	12/2007	Colleran et al.
6,447,522	B2	9/2002	Gambale et al.	7,320,692	B1	1/2008	Bender et al.
6,447,524	B1	9/2002	Knodel et al.	7,320,701	B2	1/2008	Haut et al.
6,478,803	B1	11/2002	Kapac et al.	7,322,935	B2	1/2008	Palmer et al.
6,482,178	B1	11/2002	Andrews et al.	7,326,231	B2	2/2008	Phillips et al.
6,482,210	B1	11/2002	Skiba et al.	7,343,920	B2	3/2008	Toby et al.
				7,368,124	B2	5/2008	Chun et al.
				7,377,934	B2	5/2008	Lin et al.
				7,381,213	B2	6/2008	Lizardi
				7,390,329	B2	6/2008	Westra et al.

(56)

References Cited

U.S. PATENT DOCUMENTS

7,399,304	B2	7/2008	Gambale et al.
7,404,824	B1	7/2008	Webler et al.
7,416,554	B2	8/2008	Lam et al.
7,452,368	B2	11/2008	Liberatore et al.
7,460,913	B2	12/2008	Kuzma et al.
7,463,933	B2	12/2008	Wahlstrom et al.
7,465,308	B2	12/2008	Sikora et al.
7,481,832	B1	1/2009	Meridew et al.
7,485,124	B2	2/2009	Kuhns et al.
7,497,854	B2	3/2009	Gill et al.
7,500,972	B2	3/2009	Voegele et al.
7,500,980	B2	3/2009	Gill et al.
7,500,983	B1	3/2009	Kaiser et al.
7,503,474	B2	3/2009	Hillstead et al.
7,506,791	B2	3/2009	Omaits et al.
7,559,941	B2	7/2009	Zannis et al.
7,572,276	B2	8/2009	Lim et al.
7,585,311	B2	9/2009	Green et al.
7,766,208	B2	8/2010	Epperly et al.
7,771,440	B2	8/2010	Ortiz et al.
7,776,057	B2	8/2010	Laufer et al.
7,780,685	B2	8/2010	Hunt et al.
7,785,255	B2	8/2010	Malkani
7,807,192	B2	10/2010	Li et al.
7,819,880	B2	10/2010	Zannis et al.
7,918,879	B2	4/2011	Yeung et al.
8,114,101	B2	2/2012	Criscuolo et al.
8,197,837	B2	6/2012	Jamiolkowski et al.
2002/0077687	A1	6/2002	Ahn
2002/0090725	A1	7/2002	Simpson et al.
2002/0123767	A1	9/2002	Prestel
2002/0165559	A1	11/2002	Grant et al.
2003/0073979	A1	4/2003	Naimark et al.
2003/0125748	A1	7/2003	Li et al.
2003/0212456	A1	11/2003	Lipchitz et al.
2004/0059416	A1	3/2004	Murray et al.
2004/0138705	A1	7/2004	Heino et al.
2004/0167519	A1	8/2004	Weiner et al.
2005/0015021	A1	1/2005	Shiber
2005/0049618	A1	3/2005	Masuda et al.
2005/0051597	A1	3/2005	Toledano
2005/0059996	A1	3/2005	Bauman et al.
2005/0060033	A1	3/2005	Vacanti et al.
2005/0107807	A1	5/2005	Nakao
2005/0113736	A1	5/2005	Orr et al.
2005/0171569	A1	8/2005	Girard et al.
2005/0187576	A1	8/2005	Whitman et al.
2005/0240222	A1	10/2005	Shipp
2005/0274768	A1	12/2005	Cummins et al.
2006/0074423	A1	4/2006	Alleyne et al.
2006/0178743	A1	8/2006	Carter
2006/0235442	A1	10/2006	Huitema
2006/0293760	A1	12/2006	Dedeyne
2007/0078477	A1	4/2007	Heneveld, Sr. et al.
2007/0083236	A1	4/2007	Sikora et al.
2007/0112361	A1	5/2007	Schonholz et al.
2007/0179531	A1	8/2007	Thornes
2007/0185506	A1	8/2007	Jackson
2007/0190108	A1	8/2007	Datta et al.
2007/0219558	A1	9/2007	Deutsch
2007/0270804	A1	11/2007	Chudik
2007/0288023	A1	12/2007	Pellegrino et al.
2008/0027470	A1	1/2008	Hart et al.
2008/0051888	A1	2/2008	Ratcliffe et al.
2008/0065153	A1	3/2008	Allard et al.
2008/0090936	A1	4/2008	Fujimura et al.
2008/0125869	A1	5/2008	Paz et al.
2008/0135600	A1	6/2008	Hiranuma et al.
2008/0173691	A1	7/2008	Mas et al.
2008/0188874	A1	8/2008	Henderson
2008/0188936	A1	8/2008	Ball et al.
2008/0195119	A1	8/2008	Ferree
2008/0200949	A1	8/2008	Hiles et al.
2008/0241213	A1	10/2008	Chun et al.
2008/0272173	A1	11/2008	Coleman et al.
2008/0306408	A1	12/2008	Lo
2009/0001122	A1	1/2009	Prommersberger et al.
2009/0012521	A1	1/2009	Axelson, Jr. et al.
2009/0030434	A1	1/2009	Paz et al.
2009/0069806	A1	3/2009	De La Mora Levy et al.
2009/0076541	A1	3/2009	Chin et al.
2009/0105535	A1	4/2009	Green et al.
2009/0112085	A1	4/2009	Eby
2009/0134198	A1	5/2009	Knodel et al.
2009/0156986	A1	6/2009	Trenhaile
2009/0156997	A1	6/2009	Trenhaile
2009/0182245	A1	7/2009	Zambelli
2009/0242609	A1	10/2009	Kanner
2010/0145367	A1	6/2010	Ratcliffe
2010/0147922	A1	6/2010	Olson
2010/0163598	A1	7/2010	Belzer
2010/0191332	A1	7/2010	Euteneuer et al.
2010/0241227	A1	9/2010	Euteneuer et al.
2010/0249801	A1	9/2010	Sengun et al.
2010/0256675	A1	10/2010	Romans
2010/0274278	A1	10/2010	Fleenor et al.
2010/0292715	A1	11/2010	Nering et al.
2010/0292791	A1	11/2010	Lu et al.
2010/0312250	A1	12/2010	Euteneuer et al.
2010/0312275	A1	12/2010	Euteneuer et al.
2010/0327042	A1	12/2010	Amid et al.
2011/0000950	A1	1/2011	Euteneuer et al.
2011/0004221	A1	1/2011	Euteneuer et al.
2011/0011917	A1	1/2011	Loulmet
2011/0034942	A1	2/2011	Levin et al.
2011/0040310	A1	2/2011	Levin et al.
2011/0040311	A1	2/2011	Levin et al.
2011/0066166	A1	3/2011	Levin et al.
2011/0106154	A1	5/2011	DiMatteo et al.
2011/0114700	A1	5/2011	Baxter, III et al.
2011/0224702	A1	9/2011	Van Kampen et al.
2011/0264149	A1	10/2011	Pappalardo et al.
2012/0160893	A1	6/2012	Harris et al.
2012/0193391	A1	8/2012	Michler et al.
2012/0209401	A1	8/2012	Euteneuer et al.
2012/0211543	A1	8/2012	Euteneuer
2012/0248171	A1	10/2012	Bailly et al.
2012/0316608	A1	12/2012	Foley
2013/0153627	A1	6/2013	Euteneuer et al.
2013/0153628	A1	6/2013	Euteneuer
2013/0158554	A1	6/2013	Euteneuer et al.
2013/0158587	A1	6/2013	Euteneuer et al.
2013/0158661	A1	6/2013	Euteneuer et al.
2013/0172920	A1	7/2013	Euteneuer et al.
2013/0172997	A1	7/2013	Euteneuer et al.
2013/0184716	A1	7/2013	Euteneuer et al.

FOREIGN PATENT DOCUMENTS

EP	0298400	A1	1/1989
EP	0390613	A1	10/1990
EP	0543499	A1	5/1993
EP	0548998	A1	6/1993
EP	0557963	A1	9/1993
EP	0589306	A2	3/1994
EP	0908152	A1	4/1999
EP	1491157	A1	12/2004
EP	1559379	A1	8/2005
EP	2030576	A2	3/2009
GB	2154688	A	9/1985
GB	2397240	A	7/2004
JP	58-188442		11/1983
JP	2005506122		3/2005
JP	2006515774		6/2006
WO	WO 85/05025		11/1985
WO	WO 01/76456	A2	10/2001
WO	WO 02/34140	A2	5/2002
WO	WO 03/105670	A2	12/2003
WO	WO 2004/000138	A1	12/2003
WO	WO 2004/093690	A1	11/2004
WO	WO 2005/016389	A2	2/2005
WO	WO 2006/086679	A1	8/2006
WO	WO 2007/014910	A1	2/2007
WO	WO 2007/030676	A2	3/2007

(56)

References Cited

FOREIGN PATENT DOCUMENTS

WO	WO 2007/078978	A2	7/2007
WO	WO 2007/082088	A2	7/2007
WO	WO 2008/111073	A2	9/2008
WO	WO 2008/111078	A2	9/2008
WO	WO 2008/139473	A2	11/2008
WO	WO 2009/079211	A1	6/2009
WO	WO 2009/143331	A1	11/2009
WO	WO 2011/095890	A2	8/2011
WO	WO 2011/128903	A2	10/2011

OTHER PUBLICATIONS

Bahler et al.; Trabecular bypass stents decrease intraocular pressure in cultured human anterior segments; *Am. J. Ophthalmology*; vol. 138; No. 6; pp. 988-994; Dec. 2004.

Chamay et al.; Digital contracture deformity after implantation of a silicone prosthesis: Light and electron microscopic study; *The Journal of Hand Surgery*; vol. 3; No. 3; pp. 266-270; May 1978.

D'Ermo et al.; Our results with the operation of ab externo; *Ophthalmologica*; vol. 168; pp. 347-355; (year of pub. sufficiently earlier than effective US filing date and any foreign priority date) 1971.

France et al.; Biomechanical evaluation of rotator cuff fixation methods; *The American Journal of Sports Medicine*; vol. 17; No. 2; pp. 176-181; Mar.-Apr. 1989.

Goodship et al.; An assessment of filamentous carbon fibre for the treatment of tendon injury in the horse; *Veterinary Record*; vol. 106; pp. 217-221; Mar. 8, 1980.

Hunter et al.; Flexor-tendon reconstruction in severely damaged hands; *The Journal of Bone and Joint Surgery (American Volume)*; vol. 53-A; No. 5; pp. 329-358; Jul. 1971.

Johnstone et al.; Microsurgery of Schlemm's canal and the human aqueous outflow system; *Am. J. Ophthalmology*; vol. 76; No. 6; pp. 906-917; Dec. 1973.

Kowalsky et al.; Evaluation of suture abrasion against rotator cuff tendon and proximal humerus bone; *Arthroscopy: The Journal of Arthroscopic and Related Surgery*; vol. 24; No. 3; pp. 329-334; Mar. 2008.

Lee et al.; Aqueous-venous and intraocular pressure. Preliminary report of animal studies; *Investigative Ophthalmology*; vol. 5; No. 1; pp. 59-64; Feb. 1966.

Maepea et al.; The pressures in the episcleral veins, Schlemm's canal and the trabecular meshwork in monkeys: Effects of changes in intraocular pressure; *Exp. Eye Res.*; vol. 49; pp. 645-663; Oct. 1989.

Nicolle et al.; A silastic tendon prosthesis as an adjunct to flexor tendon grafting . . . ; *British Journal of Plastic Surgery*; 22(3-4); pp. 224-236; (year of pub. sufficiently earlier than effective US filing date and any foreign priority date) 1969.

Rubin et al.; The use of acellular biologic tissue patches in foot and ankle surgery; *Clinics in Podiatric Medicine and Surgery*; nol. 22; pp. 533-552; Oct. 2005.

Schultz; Canaloplasty procedure shows promise for open-angle glaucoma in European study; *Ocular Surgery News*; pp. 34-35; Mar. 1, 2007.

Spiegel et al.; Schlemm's canal implant: A new method to lower intraocular pressure in patients with POAG; *Ophthalmic Surgery and Lasers*; vol. 30; No. 6; pp. 492-494; Jun. 1999.

Stetson et al.; Arthroscopic treatment of partial rotator cuff tears; *Operative Techniques in Sports Medicine*; vol. 12, Issue 2; pp. 135-148; Apr. 2004.

Valdez et al.; Repair of digital flexor tendon lacerations in the horse, using carbon fiber implants; *JAYMA*; vol. 177; No. 5; pp. 427-435; Sep. 1, 1980.

Wikipedia, the free encyclopedia; Rotator cuff tear; downloaded from <http://en.wikipedia.org/wiki/Rotator_cuff_tear> on Dec. 6, 2012; 14 pages.

Euteneuer et al.; U.S. Appl. No. 13/889,675 entitled "Methods and Apparatus for Fixing Sheet-Like Materials to a Target Tissue," filed May 8, 2013.

Van Kampen et al.; U.S. Appl. No. 13/889,701 entitled "Tendon repair implant and method of arthroscopic implantation," filed May 8, 2013.

Euteneuer et al.; U.S. Appl. No. 13/889,722 entitled "Apparatus and Method for Forming Pilot Holes in Bone and Delivering Fasteners Therein for Retaining an Implant," filed May 8, 2013.

Euteneuer et al.; U.S. Appl. No. 13/889,737 entitled "Fasteners and Fastener Delivery Devices for Affixing Sheet-Like Materials to Bone or Tissue," filed May 8, 2013.

Euteneuer et al.; U.S. Appl. No. 13/889,757 entitled "Methods and Apparatus for Delivering and Positioning Sheet-Like Materials in Surgery," filed May 8, 2013.

Euteneuer et al.; U.S. Appl. No. 13/889,774 entitled "Guidewire Having a Distal Fixation Member for Delivering and Positioning Sheet-Like Materials in Surgery," filed May 8, 2013.

Euteneuer et al.; U.S. Appl. No. 13/889,832 entitled "Anatomical location Markers and Methods of Use in Positioning Sheet-Like Materials During Surgery," filed May 8, 2013.

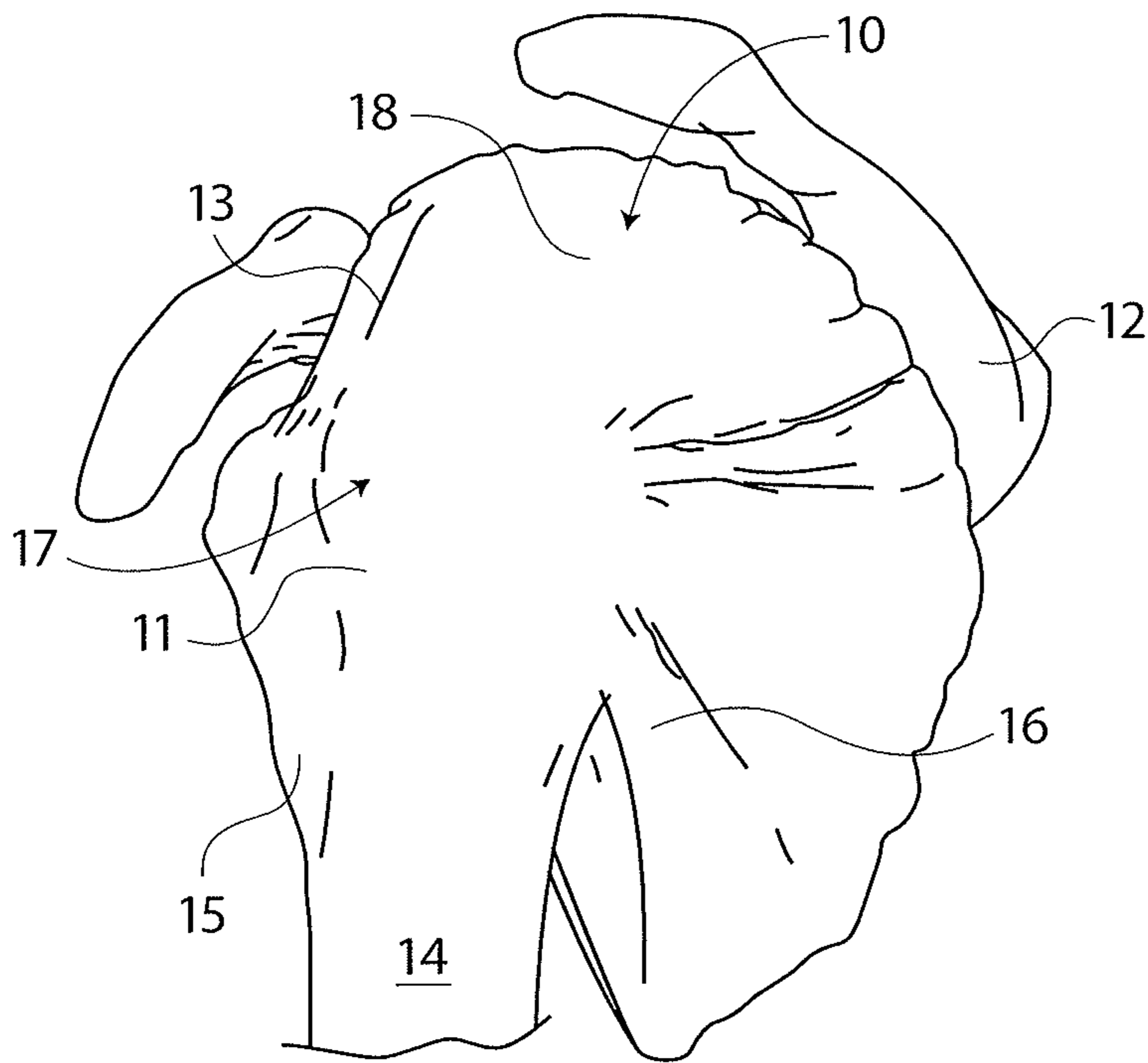

FIG. 1

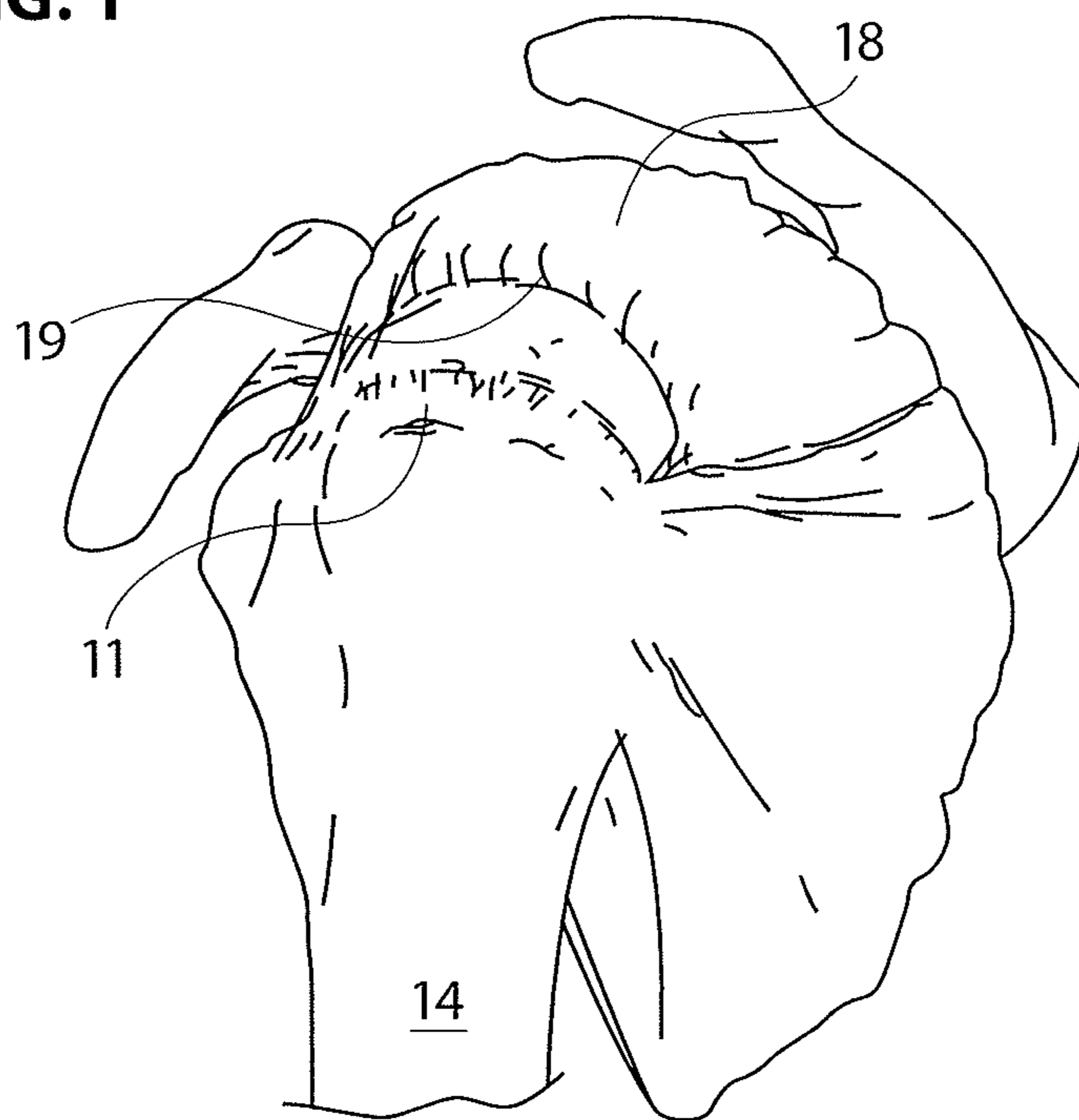

FIG. 2

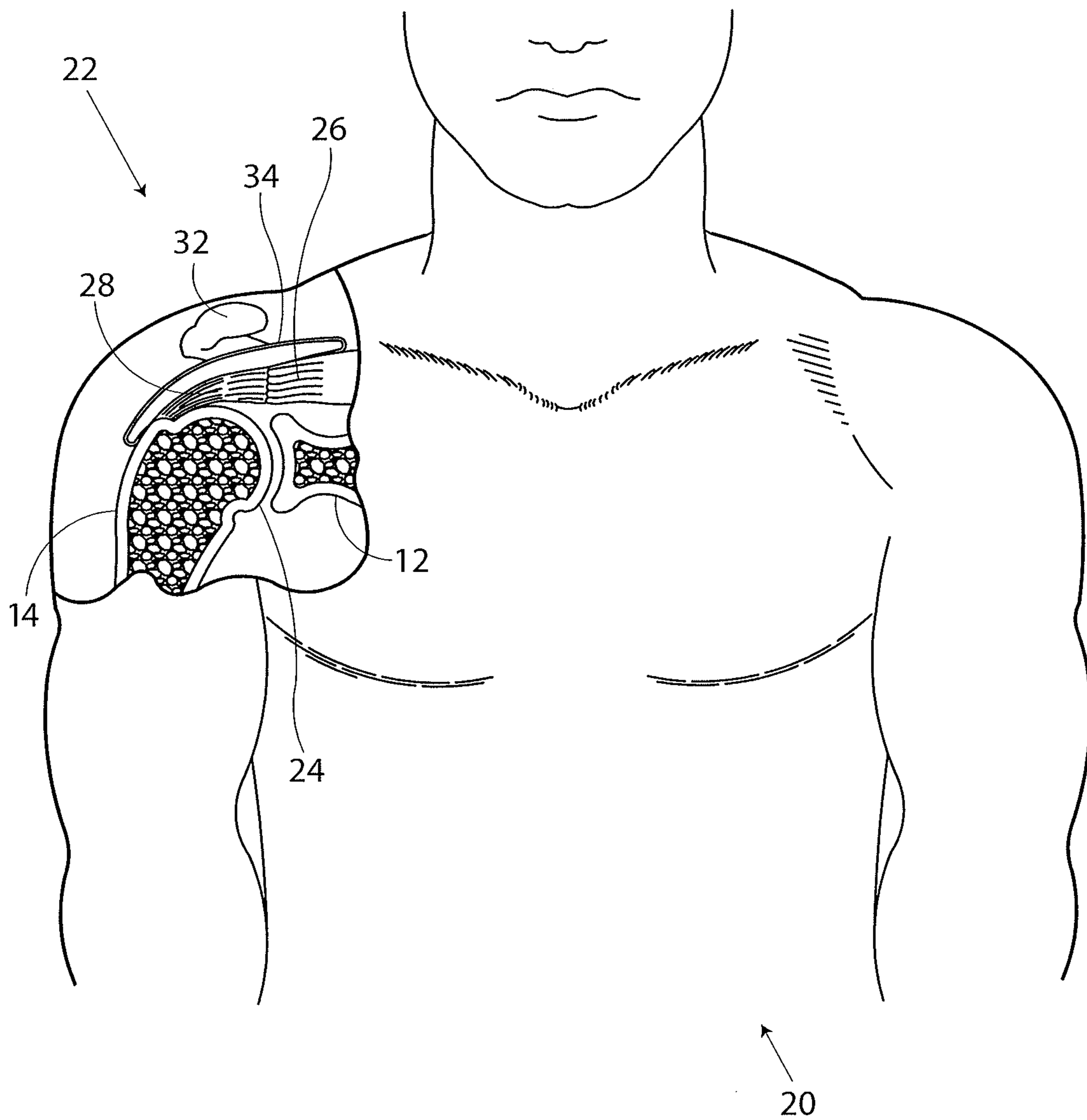

FIG. 3

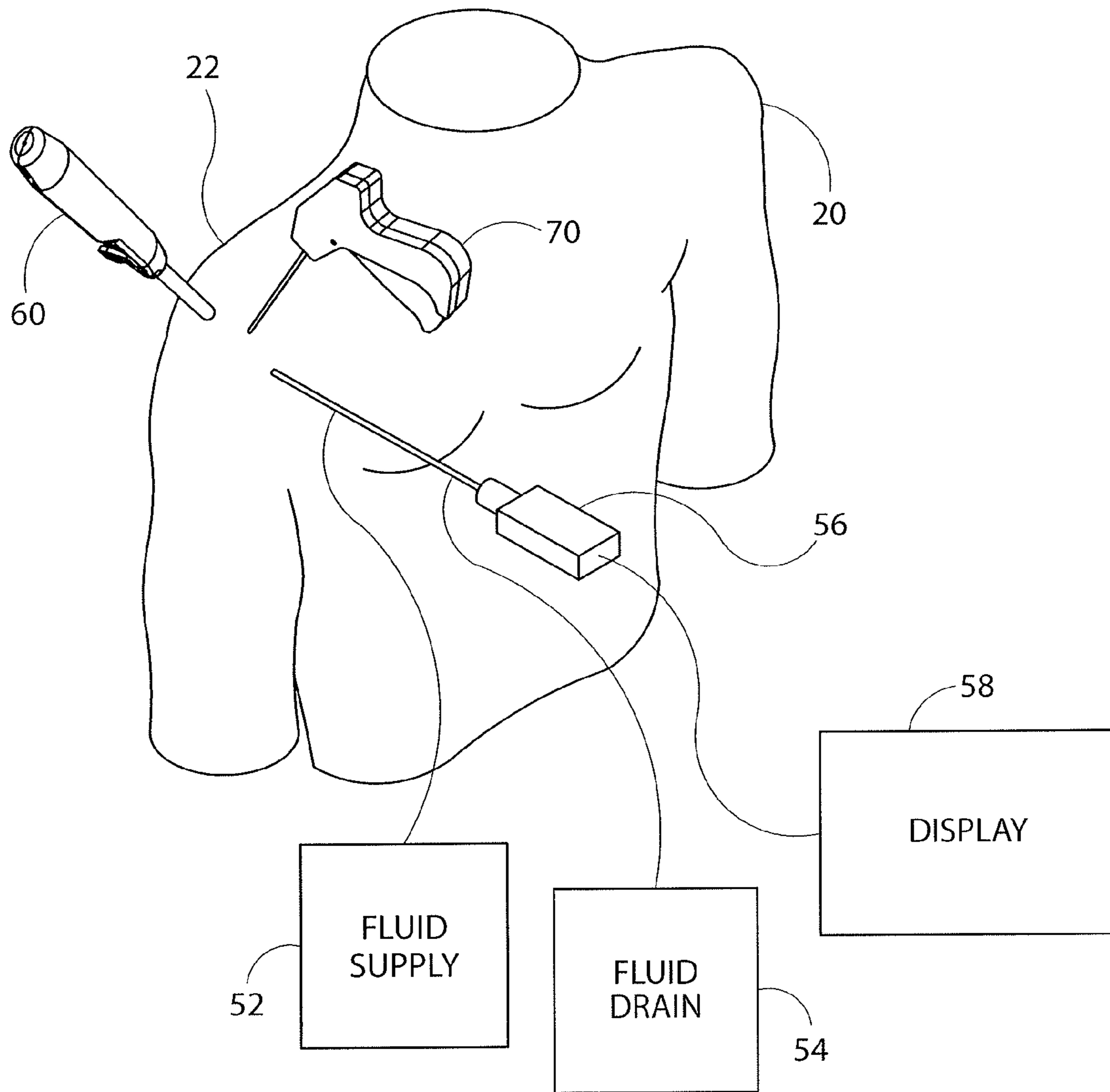

FIG. 5

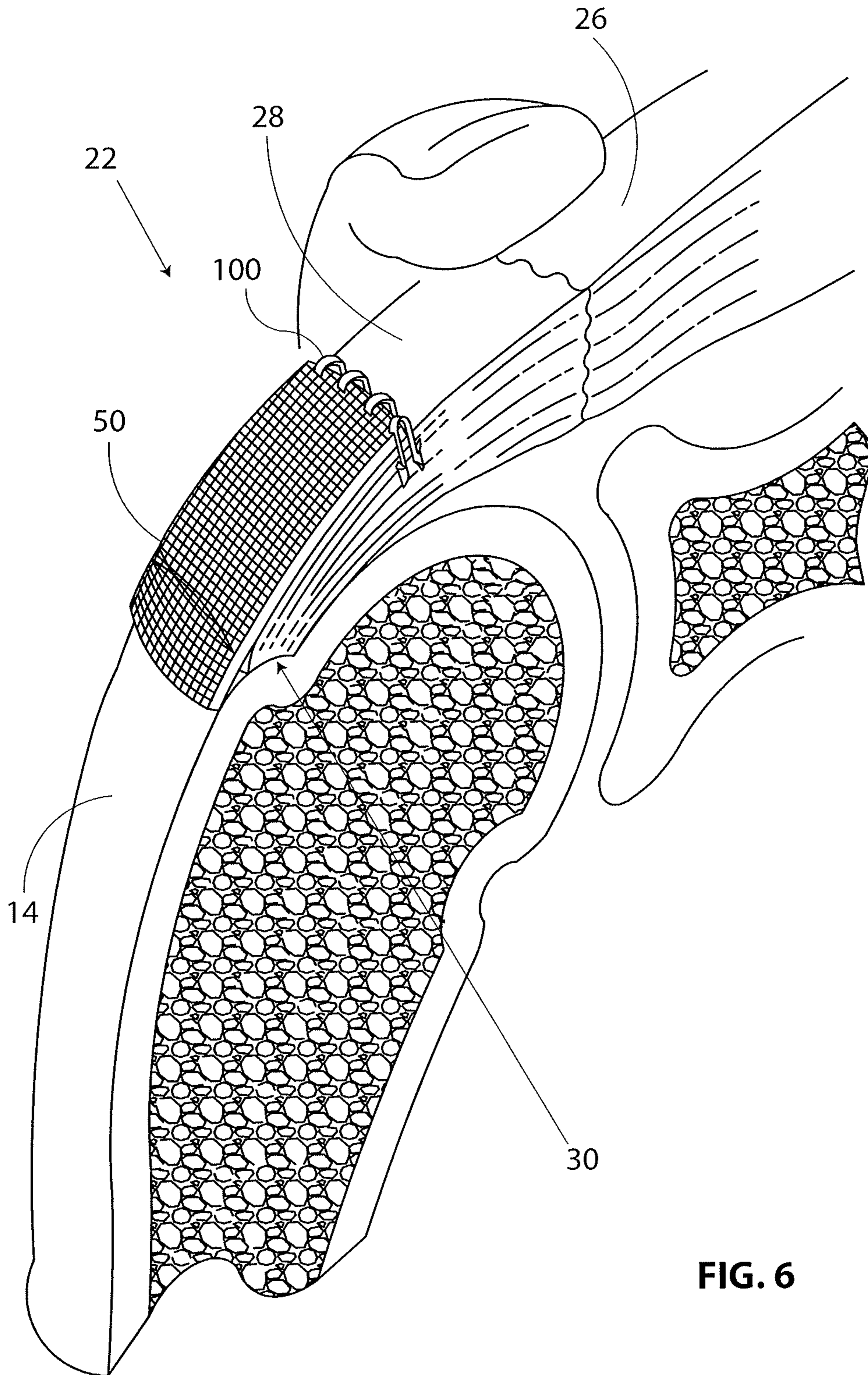

FIG. 6

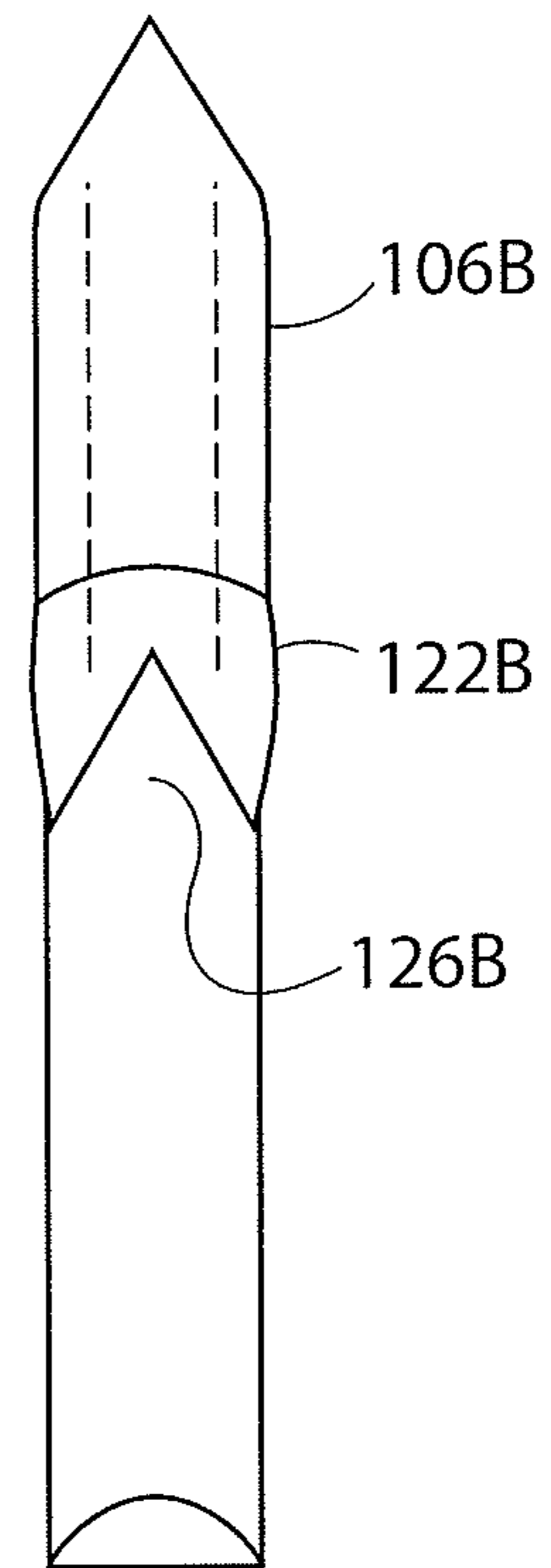
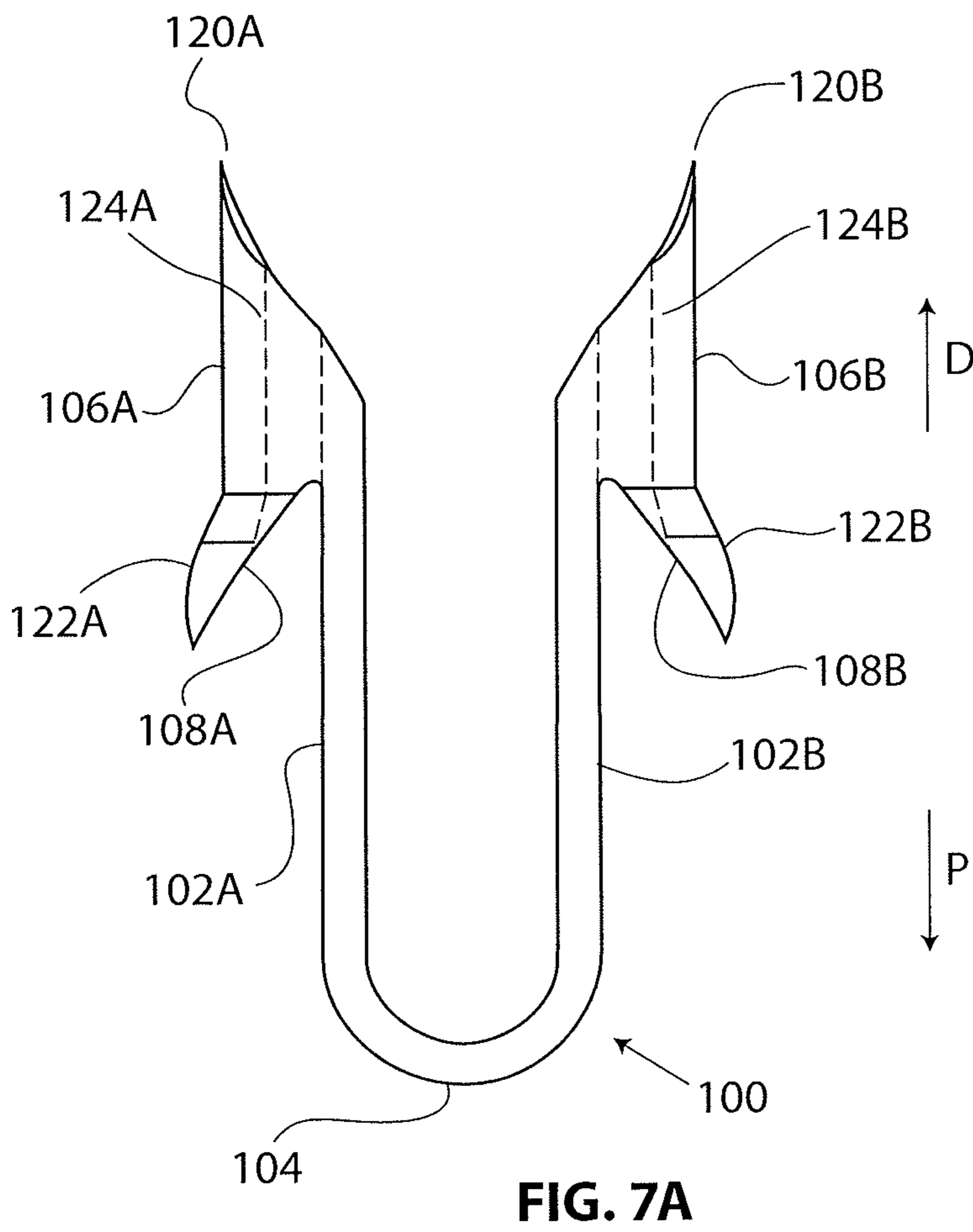
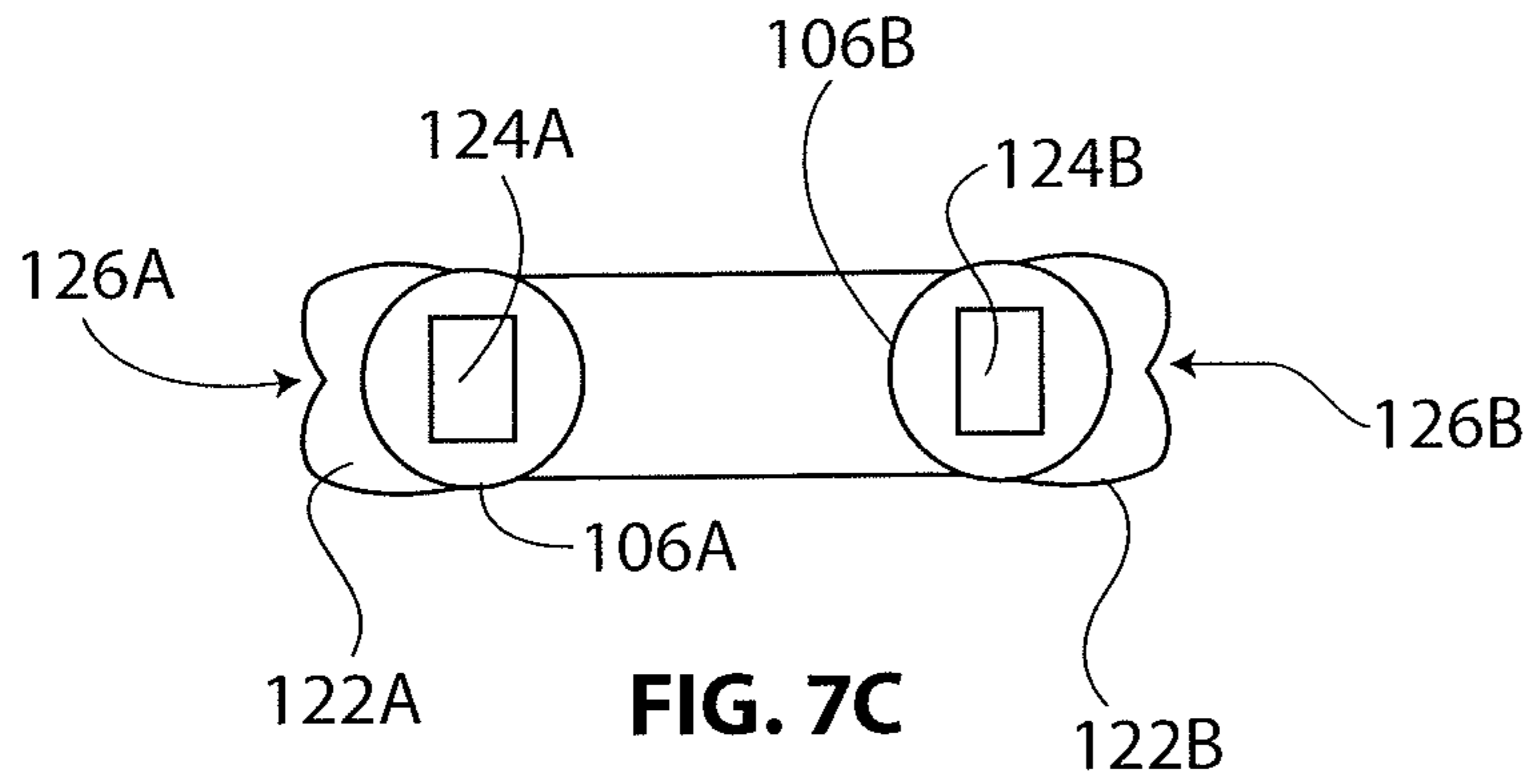

FIG. 7C

FIG. 7A

FIG. 7B

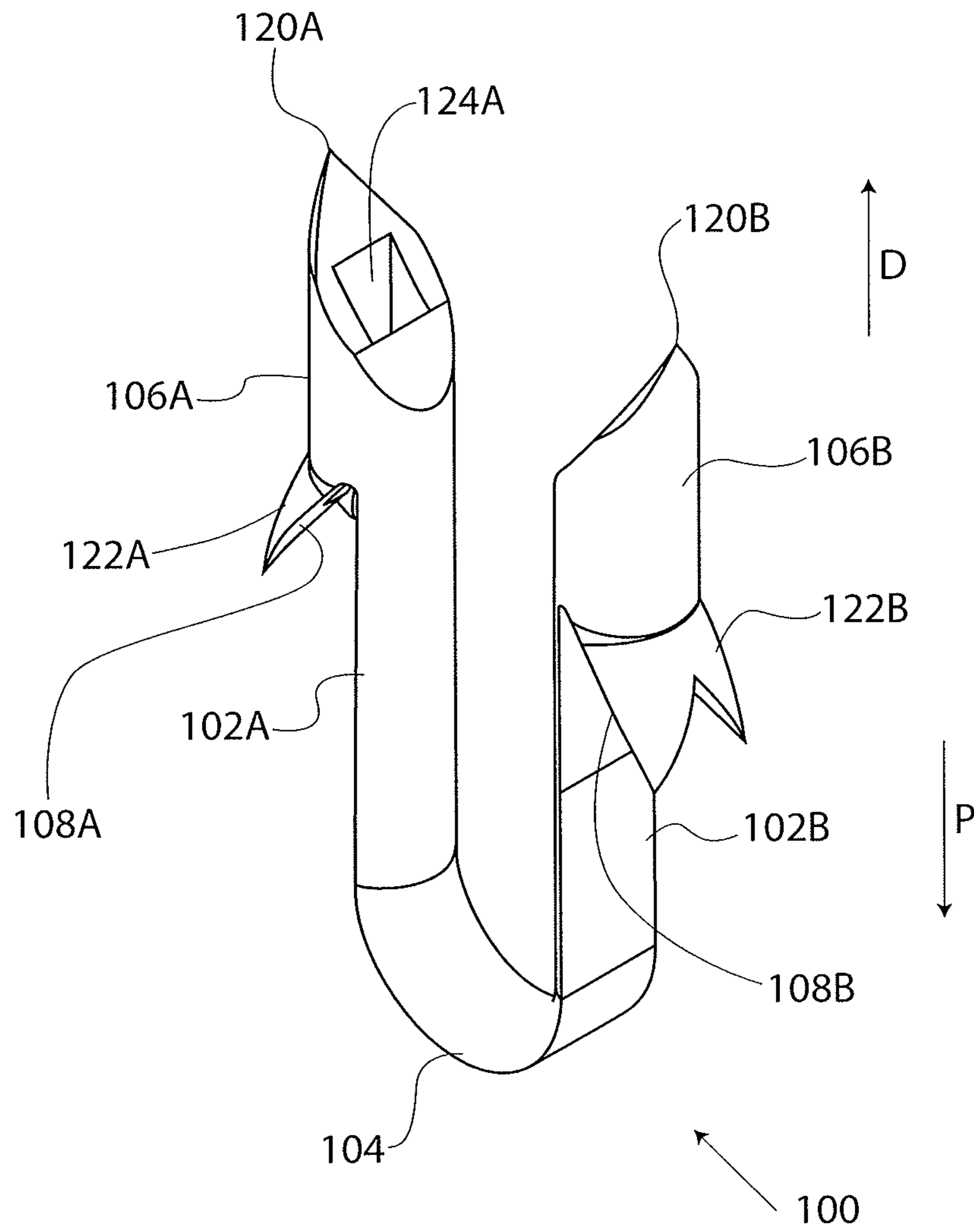

FIG. 8

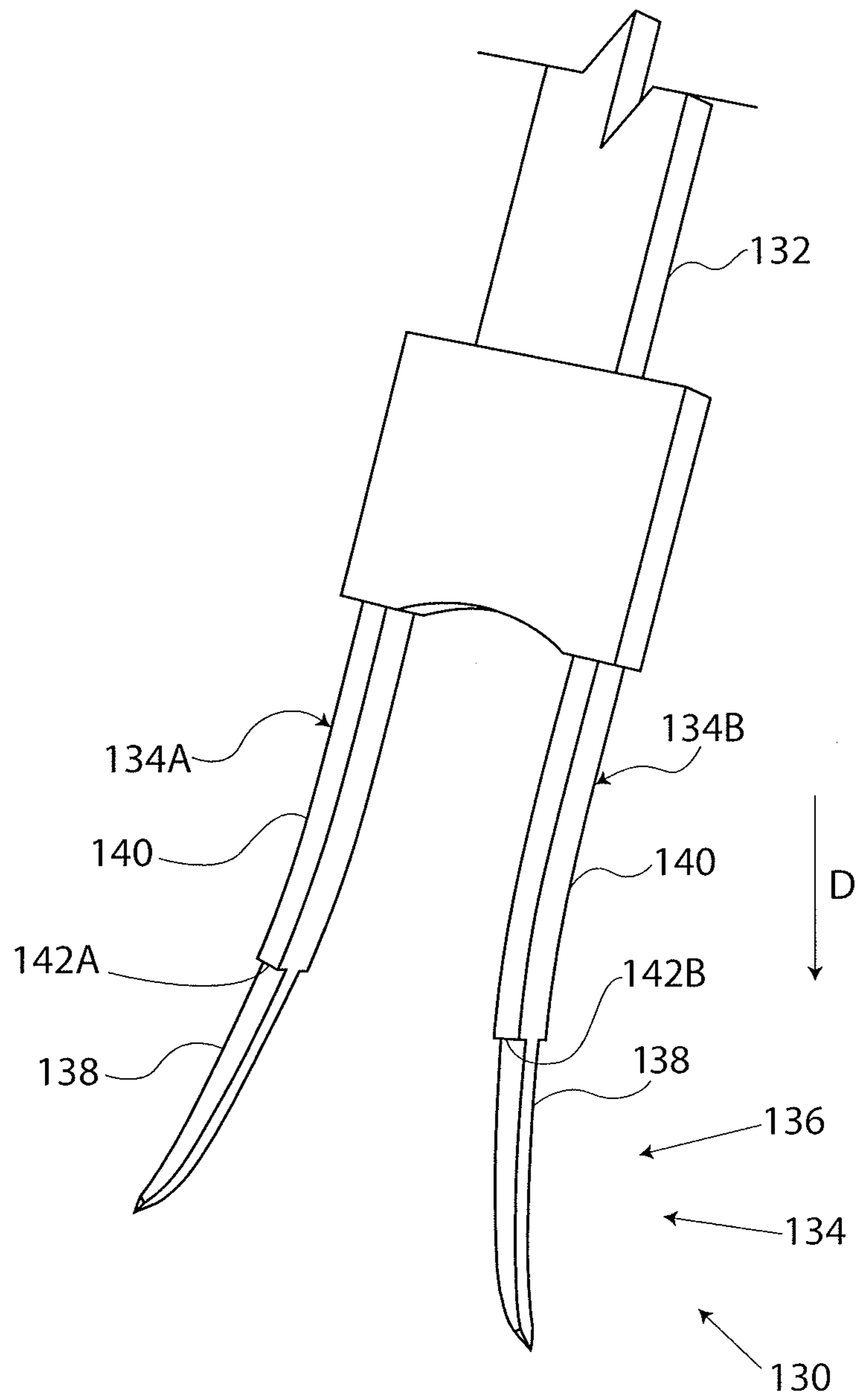

FIG. 9

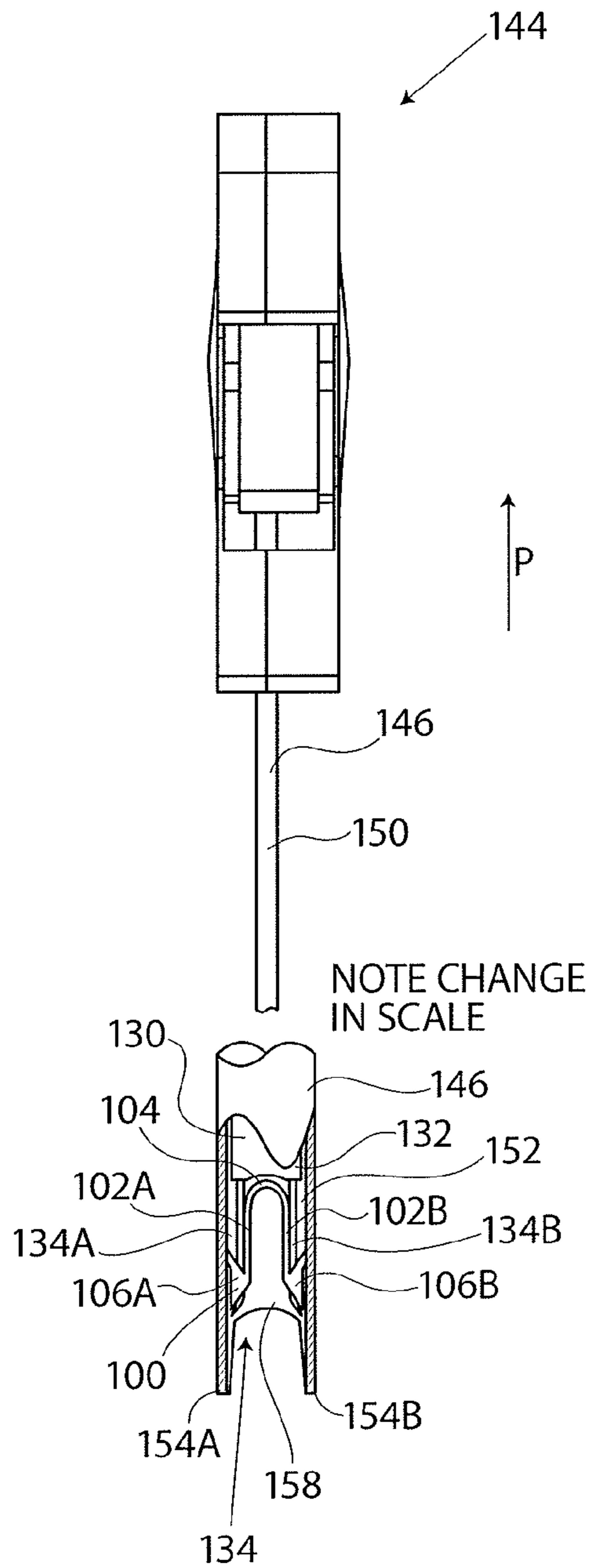

FIG. 10A

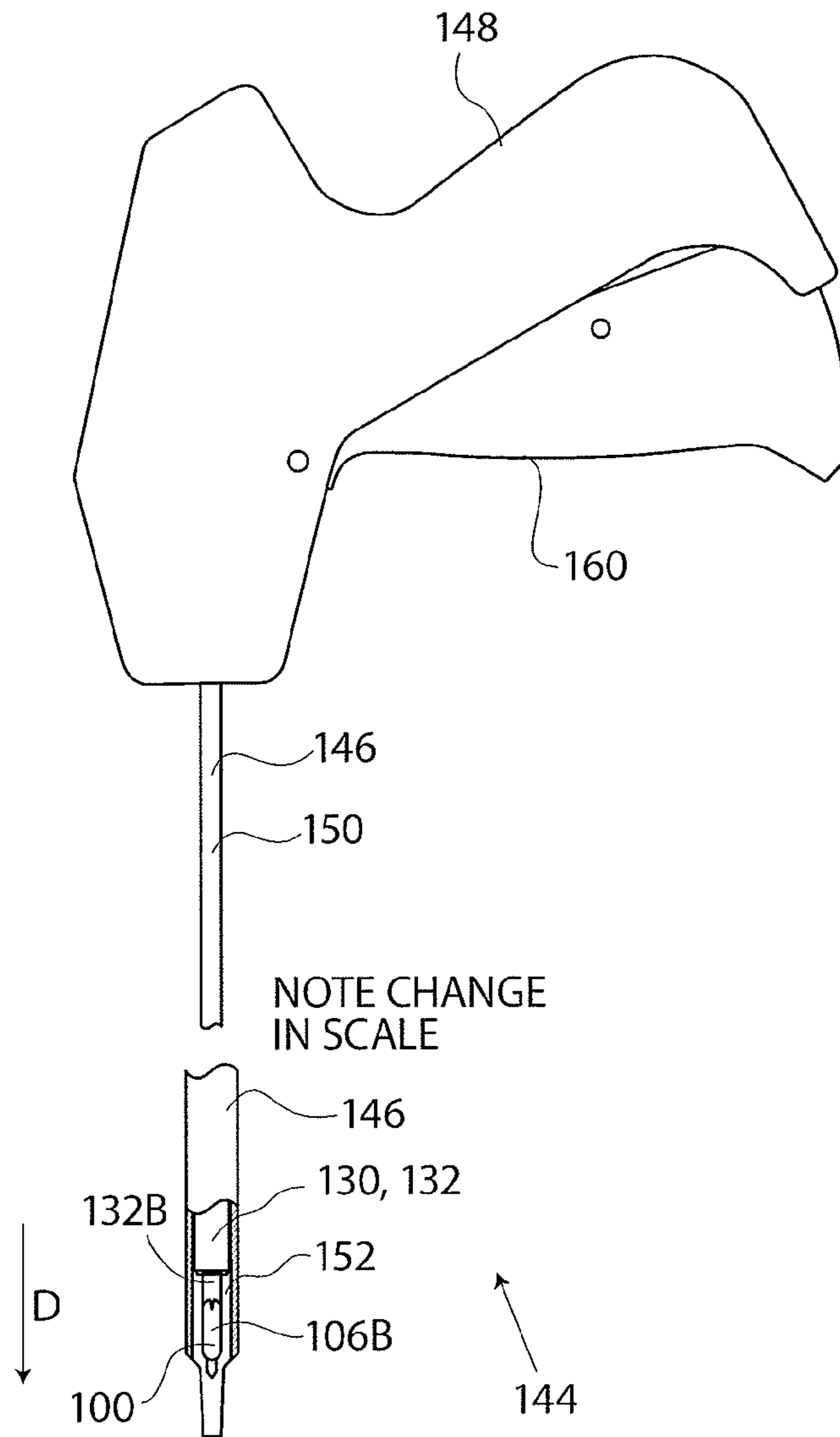

FIG. 10B

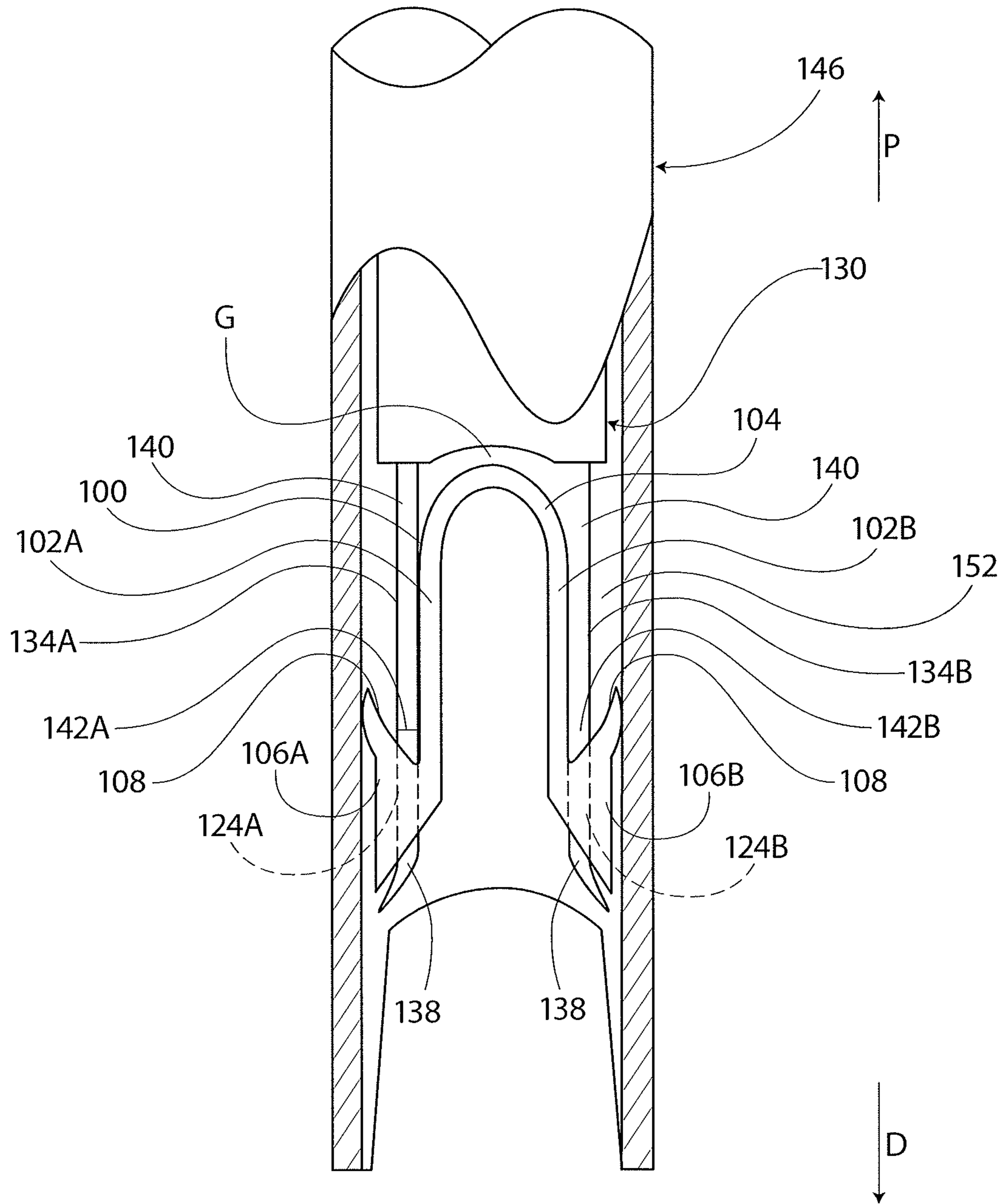

FIG. 11A

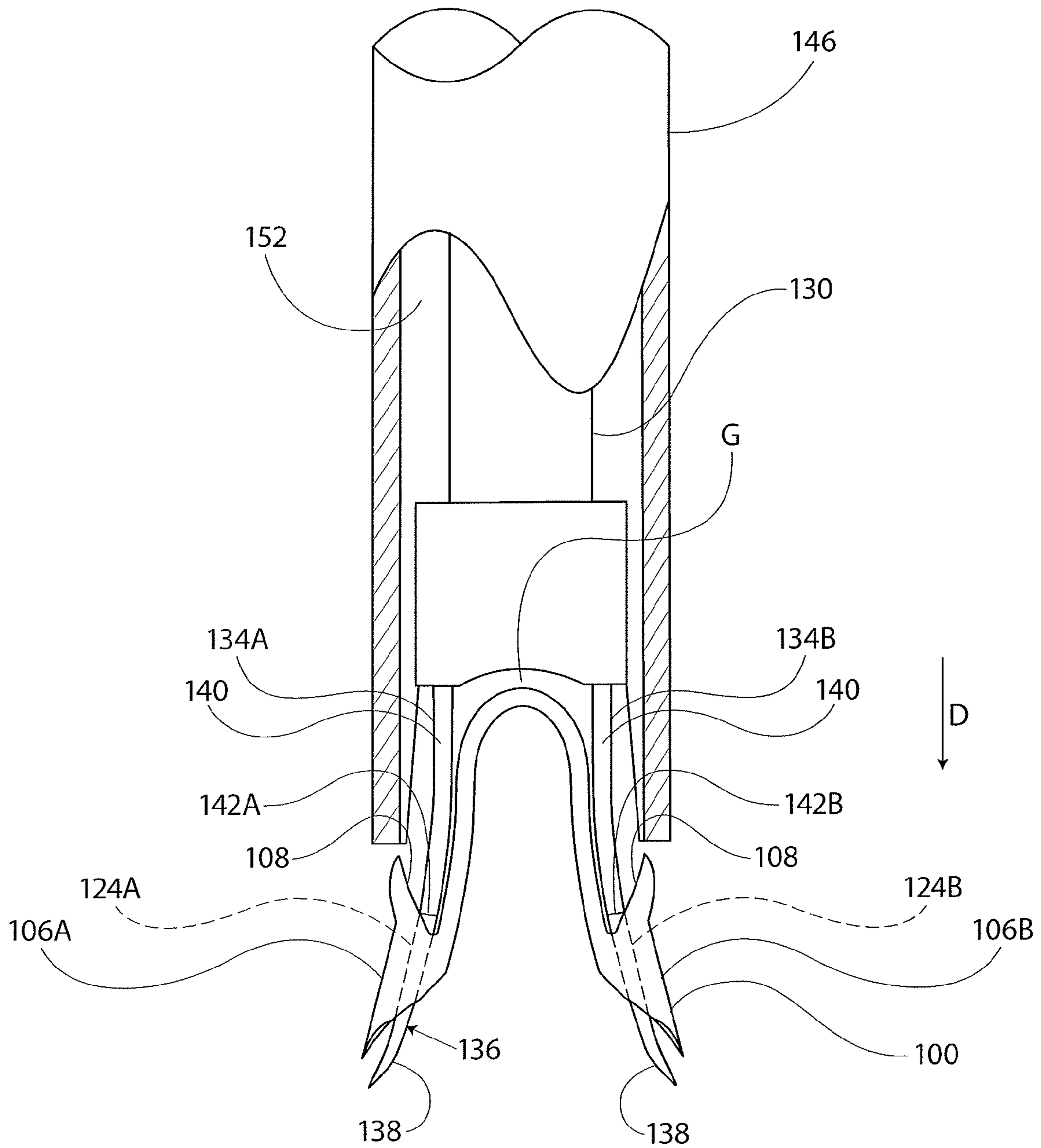

FIG. 11B

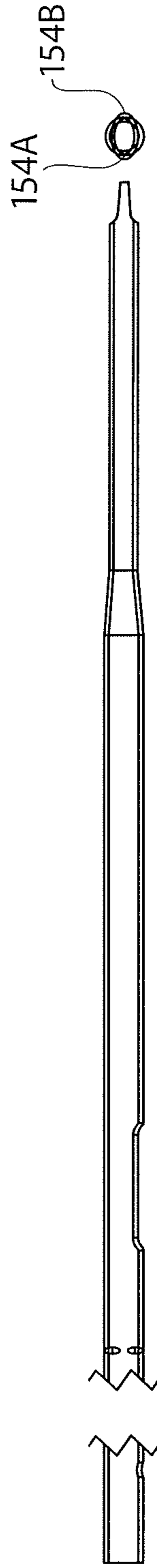

FIG. 13B

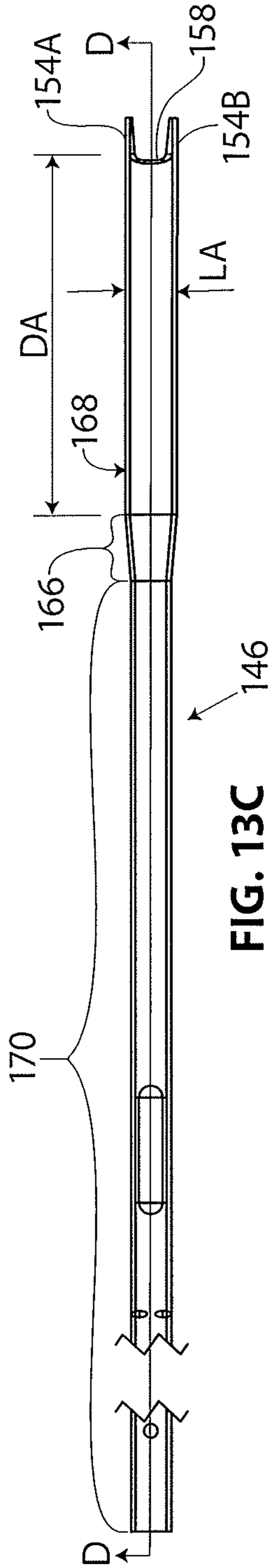

FIG. 13C

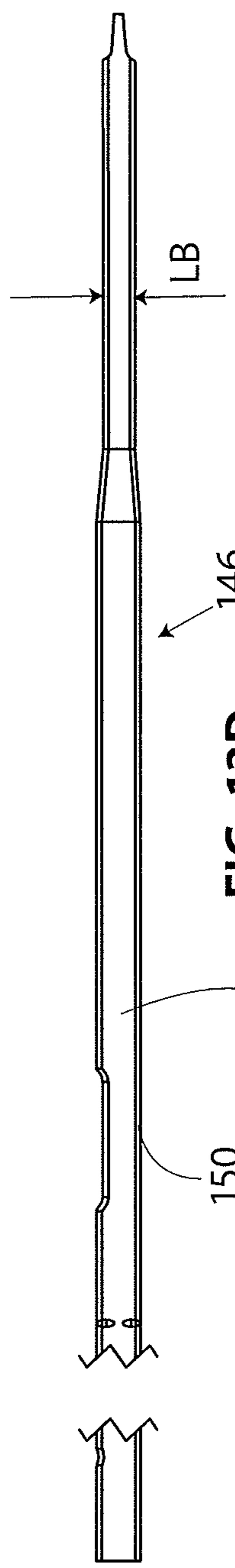
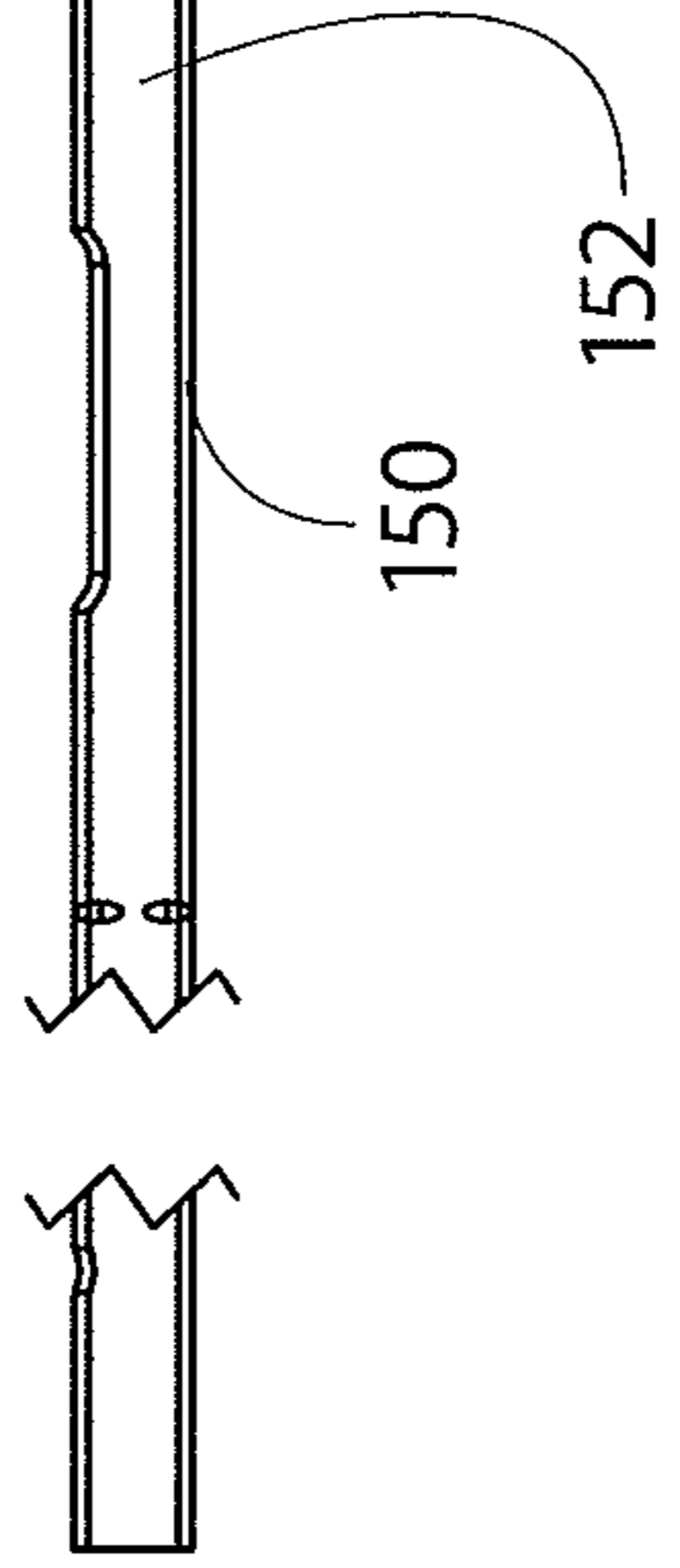

FIG. 13D



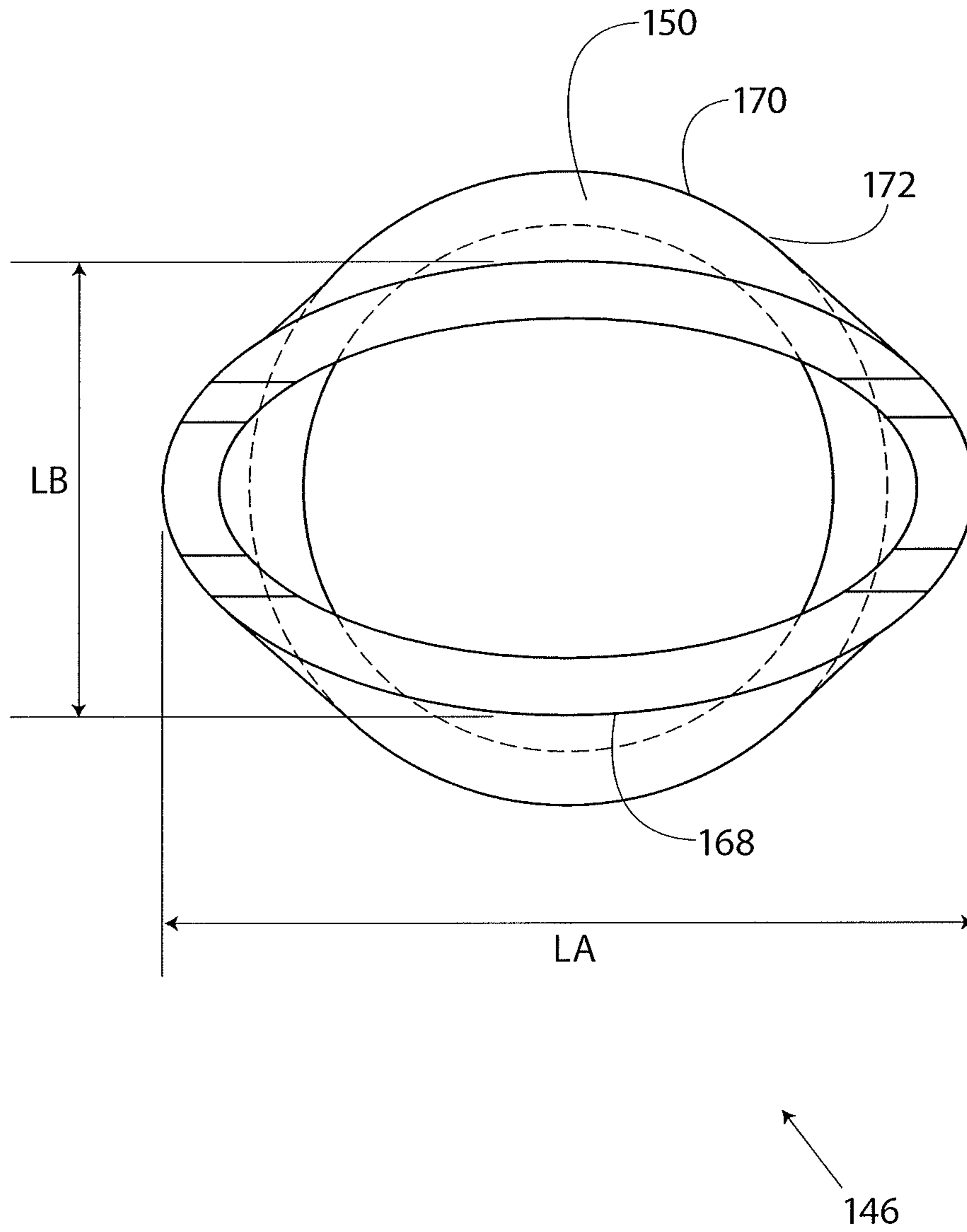

FIG. 14

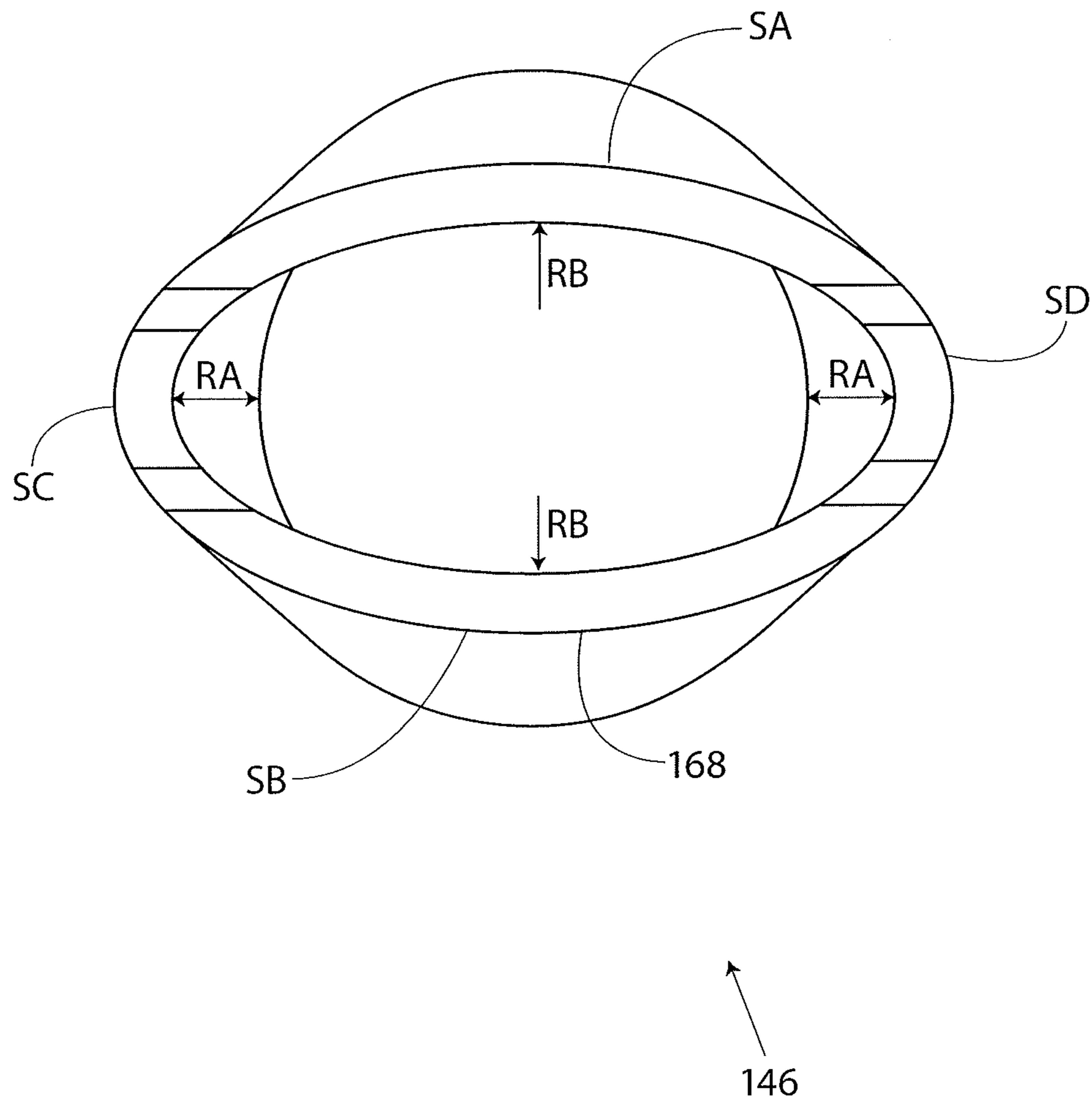

FIG. 15

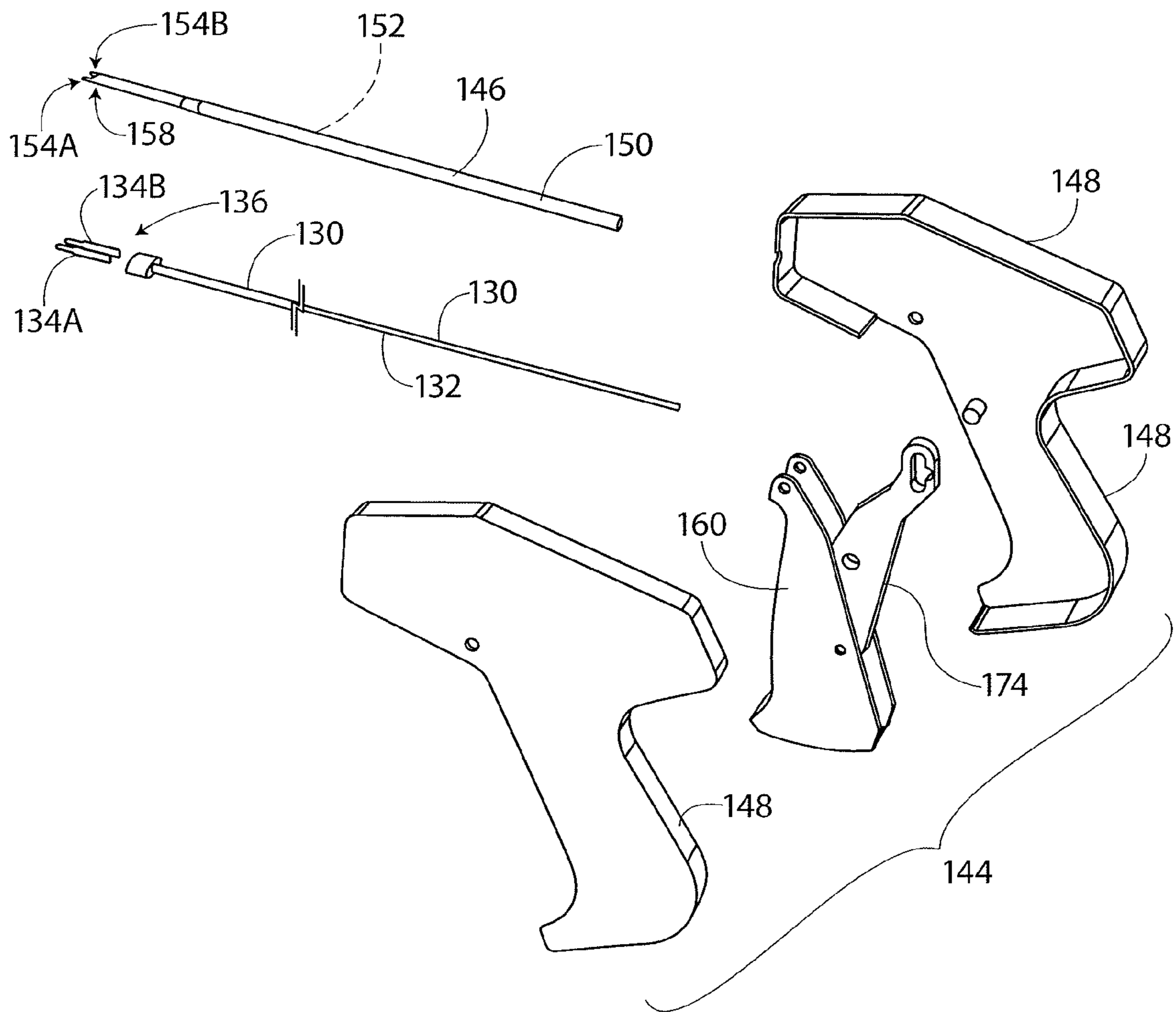

FIG. 16

METHODS AND APPARATUS FOR DELIVERING STAPLES TO A TARGET ISSUE

CROSS REFERENCE TO RELATED APPLICATIONS

The present application is a continuation of U.S. Ser. No. 12/794,551 filed on Jun. 4, 2010, which claims the benefit of: U.S. Provisional Patent Application Ser. No. 61/184,198 filed on Jun. 4, 2009; U.S. Provisional Patent Application Ser. No. 61/253,800 filed on Oct. 21, 2009; and U.S. Provisional Patent Application No. 61/313,051 file on Mar. 11, 2010, the disclosures of each are incorporated herein by reference in their entirety.

INCORPORATION BY REFERENCE

The present application is related to U.S. patent application Ser. No. 12/794,540, entitled Methods and Apparatus for Fixing Sheet-like Materials to a Target Tissue, filed on Jun. 4, 2010; U.S. patent application Ser. No. 12/794,673, entitled Methods and Apparatus for Deploying Sheet-like Materials, filed on Jun. 4, 2010; and, U.S. patent application Ser. No. 12/794,677, entitled Methods and Apparatus Having a Bow-string-like Staple Delivery to a Target Tissue, filed on Jun. 4, 2010, the disclosures of each incorporated herein by reference.

All publications and patent applications mentioned in this specification are herein incorporated by reference to the same extent as if each individual publication or patent application was specifically and individually indicated to be incorporated by reference.

FIELD OF THE INVENTION

The present invention relates generally to orthopedic medicine and surgery. More particularly, the present invention relates to methods and apparatus for delivery and fixation of sheet-like materials, such as for treating articulating joints.

BACKGROUND OF THE INVENTION

The glenohumeral joint of the shoulder is found where the head of the humerus mates with a shallow depression in the scapula. This shallow depression is known as the glenoid fossa. Six muscles extend between the humerus and scapula and actuate the glenohumeral joint. These six muscles include the deltoid, the teres major, and the four rotator cuff muscles. As disclosed by Ball et al. in U.S. Patent Publication No. US 2008/0188936 A1 and as illustrated in FIG. 1 the rotator cuff muscles are a complex of four muscles. These four muscles are the supraspinatus, the infraspinatus, the subscapularis, and the teres minor. The centering and stabilizing roles played by the rotator cuff muscles are critical to the proper function of the shoulder. The rotator cuff muscles provide a wide variety of moments to rotate the humerus and to oppose unwanted components of the deltoid and pectoralis muscle forces.

The four muscles of the rotator cuff arise from the scapula 12. The distal tendons of the rotator cuff muscles splay out and interdigitate to form a common continuous insertion on the humerus 14. The subscapularis 16 arises from the anterior aspect of the scapula 12 and attaches over much of the lesser tuberosity of the humerus. The supraspinatus muscle 18 arises from the supraspinatus fossa of the posterior scapula, passes beneath the acromion and the acromioclavicular joint, and attaches to the superior aspect of the greater tuberosity

11. The infraspinatus muscle 13 arises from the infraspinous fossa of the posterior scapula and attaches to the posterolateral aspect of the greater tuberosity 11. The teres minor 15 arises from the lower lateral aspect of the scapula 12 and attaches to the lower aspect of the greater tuberosity 11.

The mechanics of the rotator cuff muscles 10 are complex. The rotator cuff muscles 10 rotate the humerus 14 with respect to the scapula 12, compress the humeral head 17 into the glenoid fossa providing a critical stabilizing mechanism to the shoulder (known as concavity compression), and provide muscular balance. The supraspinatus and infraspinatus provide 45 percent of abduction and 90 percent of external rotation strength. The supraspinatus and deltoid muscles are equally responsible for producing torque about the shoulder joint in the functional planes of motion.

The rotator cuff muscles 10 are critical elements of this shoulder muscle balance equation. The human shoulder has no fixed axis. In a specified position, activation of a muscle creates a unique set of rotational moments. For example, the anterior deltoid can exert moments in forward elevation, internal rotation, and cross-body movement. If forward elevation is to occur without rotation, the cross-body and internal rotation moments of this muscle must be neutralized by other muscles, such as the posterior deltoid and infraspinatus. The timing and magnitude of these balancing muscle effects must be precisely coordinated to avoid unwanted directions of humeral motion. Thus the simplified view of muscles as isolated motors, or as members of force couples must give way to an understanding that all shoulder muscles function together in a precisely coordinated way—opposing muscles canceling out undesired elements leaving only the net torque necessary to produce the desired action. Injury to any of these soft tissues can greatly inhibit ranges and types of motion of the arm.

With its complexity, range of motion and extensive use, a fairly common soft tissue injury is damage to the rotator cuff or rotator cuff tendons. Damage to the rotator cuff is a potentially serious medical condition that may occur during hyperextension, from an acute traumatic tear or from overuse of the joint. With its critical role in abduction, rotational strength and torque production, the most common injury associated with the rotator cuff region is a strain or tear involving the supraspinatus tendon. A tear in the supraspinatus tendon 19 is schematically depicted in FIG. 2. A tear at the insertion site of the tendon with the humerus, may result in the detachment of the tendon from the bone. This detachment may be partial or full, depending upon the severity of the injury. Additionally, the strain or tear can occur within the tendon itself. Injuries to the supraspinatus tendon 19 and recognized modalities for treatment are defined by the type and degree of tear. The first type of tear is a full thickness tear as also depicted in FIG. 2, which as the term indicates is a tear that extends through the thickness of the supraspinatus tendon regardless of whether it is completely torn laterally. The second type of tear is a partial thickness tear which is further classified based on how much of the thickness is torn, whether it is greater or less than 50% of the thickness.

The accepted treatment for a full thickness tear or a partial thickness tear greater than 50% includes reconnecting the torn tendon via sutures. For the partial thickness tears greater than 50%, the tear is completed to a full thickness tear by cutting the tendon prior to reconnection. In contrast to the treatment of a full thickness tear or a partial thickness tear of greater than 50%, the treatment for a partial thickness tear less than 50% usually involves physical cessation from use of the tendon, i.e., rest. Specific exercises can also be prescribed to strengthen and loosen the shoulder area. In many instances,

3

the shoulder does not heal and the partial thickness tear can be the source of chronic pain and stiffness. Further, the pain and stiffness may cause restricted use of the limb which tends to result in further degeneration or atrophy in the shoulder. Surgical intervention may be required for a partial thickness tear of less than 50%, however, current treatment interventions do not include repair of the tendon, rather the surgical procedure is directed to arthroscopic removal of bone to relieve points of impingement or create a larger tunnel between the tendon and bone that is believed to be causing tendon damage. As part of the treatment, degenerated tendon may also be removed using a debridement procedure in which tendon material is ablated. Again, the tendon partial tear is not repaired. Several authors have reported satisfactory early post operative results from these procedures, but over time recurrent symptoms have been noted. In the event of recurrent symptoms, many times a patient will “live with the pain”. This may result in less use of the arm and shoulder which further causes degeneration of the tendon and may lead to more extensive damage. A tendon repair would then need to be done in a later procedure if the prescribed treatment for partial tear was unsuccessful in relieving pain and stiffness or over time the tear propagated through injury or degeneration to a full thickness tear or a partial thickness tear greater than 50% with attendant pain and debilitation. A subsequent later procedure would include the more drastic procedure of completing the tear to full thickness and suturing the ends of the tendon back together. This procedure requires extensive rehabilitation, has relatively high failure rates and subjects the patient who first presented and was treated with a partial thickness tear less than 50% to a second surgical procedure.

As described above, adequate treatments do not currently exist for repairing a partial thickness tear of less than 50% in the supraspinatus tendon. Current procedures attempt to alleviate impingement or make room for movement of the tendon to prevent further damage and relieve discomfort but do not repair or strengthen the tendon. Use of the still damaged tendon can lead to further damage or injury. Prior damage may result in degeneration that requires a second more drastic procedure to repair the tendon. Further, if the prior procedure was only partially successful in relieving pain and discomfort, a response may be to use the shoulder less which leads to degeneration and increased likelihood of further injury along with the need for more drastic surgery. There is a large need for surgical techniques and systems to treat partial thickness tears of less than 50% and prevent future tendon damage by strengthening or repairing the native tendon having the partial thickness tear.

SUMMARY OF THE INVENTION

According to aspects of the invention, a device for attaching a sheet-like implant to a target tissue is disclosed. In some embodiments, the device includes a pilot member and a staple push rod. In these embodiments, the pilot member has a distal end and at least a pair of prongs extending from the distal end. The prongs are configured to form pilot holes when the distal end of the pilot member is pressed against the target tissue. The staple push rod is disposed within at least a portion of the pilot member and slidable relative thereto. The staple push rod includes at least a pair of stakes. Each stake is dimensioned to engage a surface of a staple to apply pushing forces thereto. Each stake is positioned relative to a prong along an inner surface of the pilot member so that the stakes advance into the pilot holes when the stakes are moved in a distal direction.

4

In some embodiments of the invention, the stakes are biased to expand against an inner surface of the pilot member. Each stake has a distal portion and a proximal portion. Each distal portion may be dimensioned to extend into a passage defined by a staple. Each proximal portion may have a width larger than a width of each distal portion so that a shoulder of each proximal portion contacts a proximal surface of the staple to apply pushing forces thereto.

In some embodiments, the device also includes a staple which is carried by the staple push rod. The staple includes first and second arms, each having proximal and distal ends. A bridge extends from the proximal end of the first arm to the proximal end of the second arm. A first fluke of the staple has a proximal end abutting the distal end of the first arm. A second fluke of the staple has a proximal end abutting the distal end of the second arm. In some of these embodiments, each stake of the staple push rod has a distal portion and a proximal portion. Each distal portion extends into a passage defined by a fluke. Each proximal portion has a width larger than a width of each distal portion. This allows a shoulder of each proximal portion to contact a distal surface of a fluke to apply pushing forces thereto. The pushing forces place the first arm, the second arm, and the bridge in tension when the flukes are pushed into the target tissue. Each stake may be configured to bend at a location slightly distal of the shoulder when each fluke rotates.

In some embodiments, the proximal portion of each stake has a proximal thickness, and the distal portion of each stake has a distal thickness. The distal thickness may be configured to be less than the proximal thickness to facilitate bending of each stake at a location slightly distal of each shoulder. In some embodiments, each stake bends proximate the proximal end of a fluke when the flukes rotate. The proximal portions of the stakes may be configured with sufficient length so that there is a gap between the staple push rod and the bridge portion of staple. This allows the staple to be placed in tension without the bridge portion of the staple contacting the staple push rod.

In some embodiments, each prong of the pilot member has a length that is greater than a length of each fluke of the staple. The device may be configured such that the pushing forces include a first force applied to a proximal surface of the first fluke at a location that is offset from the first arm. The proximal portions of the stakes may be biased to diverge from one another so that the pushing force applied to each fluke has a laterally outward component. In some embodiments, a distal-most portion of each stake extends across a leading edge of each fluke.

According to aspects of the invention, methods for attaching a sheet-like implant to target tissue are also disclosed. In some embodiments, the methods include the step of providing a device that includes a pilot member. The pilot member has a distal end and at least a pair of prongs extending from the distal end. The device further includes a staple push rod carrying a staple. The staple comprises first and second arms each having proximal and distal ends. A bridge extends from the proximal end of the first arm to the proximal end of the second arm. The staple further comprises a first fluke having a proximal end abutting the distal end of the first arm, and a second fluke having a proximal end abutting the distal end of the second arm. The staple push rod of the device includes a pair of stakes, each having distal and proximal portions. Each distal portion extends into a passage defined by a fluke. Each proximal portion has a width larger than a width of each distal portion so that a shoulder of each proximal portion contacts a distal surface of a fluke.

The above methods further include the step of piercing the target tissue with the first prong of the pilot member to create a first pilot hole, and piercing the target tissue with the second prong to create a second pilot hole. The first fluke is positioned near the first pilot hole and the second fluke is positioned near the second pilot hole. The staple push rod is advanced in a distal direction so that the stakes apply pushing forces to the flukes. This causes the flukes to advance into the pilot holes and causes the first arm, the second arm, and the bridge to be placed in tension. The first arm provides a first reaction force when placed in tension and the second arm provides a second reaction force when placed in tension. The pushing forces and reaction forces cooperate to produce a moment applied to each fluke. The moment applied to each fluke causes each fluke to rotate so that each fluke assumes a locked position. When in the locked position, the longitudinal axis of each fluke is skewed relative to a longitudinal axis of the pilot member.

In some embodiments, a first moment having a first direction is applied to the first fluke, and a second moment having a second direction is applied to the second fluke. In these embodiments, the first direction is different from the second direction. In some embodiments, the first direction is generally opposite the second direction. The first direction may be a clockwise direction while the second direction is a counterclockwise direction. In some embodiments, a first pushing force is applied to the proximal surface of the first fluke at a location that is offset from the first arm. The first pushing force may be in a direction that is generally parallel to a central axis of the first pilot hole.

In some embodiments, the flukes are advanced into the pilot holes while the prongs are disposed in the pilot holes. The methods may further include the step of moving the pilot member in a proximal direction relative to the target tissue until a distal end of the first prong is located proximal of the first fluke and a distal end of the second prong is located proximally of the second fluke. The step of advancing the staple push rod in a distal direction may include actuating a mechanism that produces relative motion between the staple push rod and the pilot member while applying a distally directed force to the pilot member.

In some of the above embodiments, moving the pilot member in a proximal direction relative to the target tissue includes producing relative motion between the staple push rod and the pilot member while applying a distally directed force to the pilot member. The first fluke may assume a first locking position and the second fluke may assume a second locking position while a distal end of the first prong is located proximal of the first fluke and a distal end of the second prong is located proximally of the second fluke.

According to aspects of the invention, a device for attaching a sheet-like implant to a target tissue is disclosed. In some embodiments the device includes a pilot member, a staple push rod slidably disposed within at least a portion of the pilot member, and a staple carried by the push rod. In these embodiments, the pilot member has a distal end and at least a pair of prongs extending from the distal end. The staple comprises first and second arms, each having proximal and distal ends. A bridge extends from the proximal end of the first arm to the proximal end of the second arm. A first fluke of the staple has a proximal end abutting the distal end of the first arm, and a second fluke of the staple has a proximal end abutting the distal end of the second arm. The staple push rod includes a pair of stakes, each having distal and proximal portions. The distal portion of each stake extends into a passage defined by a fluke. Each proximal portion has a width larger than a width of each distal portion.

With the above arrangement, a shoulder of each proximal portion contacts a distal surface of a fluke to apply pushing forces thereto. The pushing forces place the first arm, the second arm, and the bridge in tension when the flukes are pushed into the target tissue. The first arm provides a first reaction force when placed in tension, and the second arm provides a second reaction force when placed in tension. The pushing forces and the reaction forces cooperate to produce a moment applied to each fluke. The moment applied to each fluke causes each fluke to rotate so that each fluke assumes a locked position. When in the locked position, the longitudinal axis of each fluke is skewed relative to an arm of the staple.

Further aspects of the present invention will become apparent after review of the Detailed Description with reference to the following drawings.

BRIEF DESCRIPTION OF THE DRAWINGS

FIG. 1 is a simplified perspective view of the human rotator cuff and associated anatomical structure.

FIG. 2 is a schematic depiction of a full thickness tear in the supraspinatus tendon of the rotator cuff of FIG. 1.

FIG. 3 is a stylized anterior view of a patient with a shoulder of patient being shown in cross-section for purposes of illustration.

FIG. 4 is a stylized anterior view of a shoulder including a humerus and a scapula. The head of the humerus is shown mating with the glenoid fossa of the scapula at a glenohumeral joint and a sheet-like material is fixed to the tendon.

FIG. 5 is a stylized perspective view illustrating an exemplary procedure for treating a shoulder of a patient.

FIG. 6 is a stylized perspective view of a shoulder including a supraspinatus having a distal tendon with a sheet-like material fixed thereto. A proximal end of the supraspinatus is fixed to the scapula and the distal tendon of the supraspinatus is fixed to the humerus.

FIG. 7A, FIG. 7B, and FIG. 7C are multiple plan views illustrating an exemplary staple in accordance with the present detailed description.

FIG. 8 is a perspective view further illustrating the staple shown in the previous Figure.

FIG. 9 is a perspective view showing a staple push rod that may be used in conjunction with the staple shown in the previous Figure.

FIG. 10A and FIG. 10B illustrate multiple plan views of an exemplary fixation tool in accordance with the present detailed description.

FIG. 11A is a further enlarged partial cross-sectional view of a distal portion of the fixation tool shaft shown in the previous Figure.

FIG. 11B is an additional partial cross-sectional view showing a staple carried by a staple push rod and a fixation tool shaft disposed about the staple push rod.

FIG. 12A through FIG. 12C are a sequence of plan views illustrating an exemplary method and apparatus in accordance with the present detailed description.

FIG. 13A, FIG. 13B, FIG. 13C and FIG. 13D are multiview projections illustrating a fixation tool shaft shown in the previous Figures.

FIG. 14 is an enlarged axial view of the fixation tool shaft shown in the previous Figure.

FIG. 15 is an additional enlarged axial view of the fixation tool shaft shown in the previous Figure.

FIG. 16 is an exploded isometric view of an exemplary fixation tool in accordance with this detailed description.

DETAILED DESCRIPTION OF THE INVENTION

The following detailed description should be read with reference to the drawings in which similar elements in different drawings are numbered the same. The drawings, which are not necessarily to scale, depict illustrative embodiments and are not intended to limit the scope of the invention.

As used herein, the term “tissue” refers to soft tissue, such as a tendon, and/or bone tissue, depending on the context in which it is used.

FIG. 3 is a stylized anterior view of a patient 20. For purposes of illustration, a shoulder 22 of patient 20 is shown in cross-section in FIG. 3. Shoulder 22 includes a humerus 14 and a scapula 12. In FIG. 3, a head 24 of humerus 14 can be seen mating with a glenoid fossa of scapula 12 at a glenohumeral joint. With reference to FIG. 3, it will be appreciated that the glenoid fossa comprises a shallow depression in scapula 12. The movement of humerus 14 relative to scapula 12 is controlled by a number of muscles including: the deltoid, the supraspinatus, the infraspinatus, the subscapularis, and the teres minor. For purposes of illustration, only the supraspinatus 26 is shown in FIG. 3.

With reference to FIG. 3, it will be appreciated that a distal tendon 28 of the supraspinatus 26 meets humerus 14 at an insertion point. Scapula 12 of shoulder 22 includes an acromion 32. In FIG. 3, a subacromial bursa 34 is shown extending between acromion 32 of scapula 12 and head 24 of humerus 14. In FIG. 3, subacromial bursa 34 is shown overlaying supraspinatus 26. Subacromial bursa 34 is one of the hundreds of bursae found the human body. Each bursa comprises a fluid filled sac. The presence of these bursae in the body reduces friction between bodily tissues. Injury and/or infection of the bursa can cause it to become inflamed. This condition is sometimes referred to as bursitis.

The exemplary methods and apparatus described herein may be used to fix tendon repair implants to various target tissues. For example, a tendon repair implant may be fixed to one or more tendons associated with an articulating joint, such as the glenohumeral joint. The tendons to be treated may be torn, partially torn, have internal micro-tears, be untorn, and/or be thinned due to age, injury or overuse. Applicants believe that the methods and apparatus of the present application and related devices may provide very beneficial therapeutic effect on a patient experiencing joint pain believed to be caused by partial thickness tears and/or internal microtears. By applying a tendon repair implant early before a full tear or other injury develops, the implant may cause the tendon to thicken and/or at least partially repair itself, thereby avoiding more extensive joint damage, pain, and the need for more extensive joint repair surgery.

FIG. 4 is a stylized anterior view of a shoulder 22 including a humerus 14 and a scapula 12. In FIG. 4, a head 24 of humerus 14 is shown mating with a glenoid fossa of scapula 12 at a glenohumeral joint. A supraspinatus 26 is also shown in FIG. 4. This muscle (along with others) control the movement of humerus 14 relative to scapula 12. A distal tendon 28 of supraspinatus 26 meets humerus 14 at an insertion point 30.

In the embodiment of FIG. 4, distal tendon 28 includes a first damaged portion 36. A number of loose tendon fibers 40 in first damaged portion 36 are visible in FIG. 4. First damaged portion 36 includes a first tear 42 extending partially through distal tendon 28. First tear 42 may therefore be referred to as a partial thickness tear. With reference to FIG. 4, it will be appreciated that first tear 42 begins on the side of distal tendon 28 facing the subacromial bursa (shown in the

previous Figure) and ends midway through distal tendon 28. Accordingly, first tear 42 may be referred to as a bursal side tear.

With reference to FIG. 4, it will be appreciated that distal tendon 28 includes a second damaged portion 38 located near insertion point 30. In the embodiment of FIG. 4, second damaged portion 38 of distal tendon 28 has become frayed and a number of loose tendon fibers 40 are visible in FIG. 4. Second damaged portion 38 of distal tendon 28 includes second tear 44. With reference to FIG. 4, it will be appreciated that second tear 44 begins on the side of distal tendon 28 facing the humerus 14. Accordingly, second damaged portion 38 may be referred to as an articular side tear.

In the embodiment of FIG. 4, a sheet-like implant 50 has been placed over the bursal side of distal tendon 28. With reference to FIG. 4, it will be appreciated that sheet-like implant 50 extends over insertion point 30, first tear 42 and second tear 44. Some useful methods in accordance with this detailed description may include placing a tendon repair implant on the bursal side of a tendon regardless of whether the tears being treated are on the bursal side, articular side or within the tendon. In some cases the exact location and nature of the tears being treated may be unknown. A tendon repair implant may be applied to the bursal side of a tendon to treat shoulder pain that is most likely caused by one or more partial thickness tears in the tendon. In the embodiment of FIG. 4, sheet-like implant 50 is fixed to distal tendon 28 and to humerus 14 by a plurality of staples 100 as described herein in detail.

FIG. 5 is a stylized perspective view illustrating an exemplary procedure for treating a shoulder 22 of a patient 20. The procedure illustrated in FIG. 5 may include, for example, fixing tendon repair implants to one or more tendons of shoulder 22. The tendons treated may be torn, partially torn, have internal micro-tears, be untorn, and/or be thinned due to age, injury or overuse.

Shoulder 22 of FIG. 5 has been inflated to create a cavity therein. In the exemplary embodiment of FIG. 5A, a fluid supply 52 is pumping a continuous flow of saline into the cavity. This flow of saline exits the cavity via a fluid drain 54. A camera 56 provides images from inside the cavity. The images provided by camera 56 may be viewed on a display 58.

Camera 56 may be used to visually inspect the tendons of shoulder 22 for damage. A tendon repair implant in accordance with this disclosure may be fixed to a bursal surface of the tendon regardless of whether there are visible signs of tendon damage. Applicants believe that the methods and apparatus of the present application and related devices may provide very beneficial therapeutic effect on a patient experiencing joint pain believed to be caused by internal microtears, but having no clear signs of tendon tears. By applying a tendon repair implant early before a full tear or other injury develops, the implant may cause the tendon to thicken and/or at least partially repair itself, thereby avoiding more extensive joint damage, pain, and the need for more extensive joint repair surgery.

A delivery system 60 can be seen extending from shoulder 22 in FIG. 5. Delivery system 60 comprises a sheath that is fixed to a handle. The sheath defines a lumen and a distal opening fluidly communicating the lumen. In the embodiment of FIG. 5, the distal opening of the sheath has been placed in fluid communication with the cavity created in shoulder 22.

A tendon repair implant is at least partially disposed in the lumen defined by the sheath of delivery system 60. Delivery system 60 can be used to place the tendon repair implant

inside shoulder 22. Delivery system 60 can also be used to hold the tendon repair implant against the tendon. In some embodiments, the tendon repair implant is folded into a compact configuration when inside the lumen of the sheath. When this is the case, delivery system 60 may be used to unfold the tendon repair implant into an expanded shape.

The tendon repair implant may be fixed to the tendon while it is held against the tendon by delivery system 60. Various attachment elements may be used to fix the tendon repair implant to the tendon. Examples of attachment elements that may be suitable in some applications include sutures, tissue anchors, bone anchors, and staples. In the exemplary embodiment of FIG. 5, the shaft of a fixation tool 70 is shown extending into shoulder 22. In one exemplary embodiment, fixation tool 70 is capable of fixing the tendon repair implant to the tendon with one or more staples while the tendon repair implant is held against the tendon by delivery system 60.

FIG. 6 is a stylized perspective view of a shoulder 22 including a supraspinatus 26 having a distal tendon 28. With reference to FIG. 6, it will be appreciated that a tendon repair implant 50 has been fixed to a surface of distal tendon 28. Tendon repair implant 50 may comprise, for example, various sheet-like structures without deviating from the spirit and scope of the present detailed description. In some useful embodiments, the sheet-like structure may comprise a plurality of fibers. The fibers may be interlinked with one another. When this is the case, the sheet-like structure may comprise a plurality of apertures comprising the interstitial spaces between fibers. Various processes may be used to interlink the fibers with one another. Examples of processes that may be suitable in some applications including weaving, knitting, and braiding. In some embodiment, the sheet-like structure may comprise a laminate including multiple layers of film with each layer of film defining a plurality of micro-machined or formed holes. The sheet-like structure of the tendon repair implant may also comprise a plurality of electro-spun nanofiber filaments forming a composite sheet. Additionally, the sheet-like structure may comprise a synthetic sponge material that defines a plurality of pores. The sheet-like structure may also comprise a reticulated foam material. Reticulated foam materials that may be suitable in some applications are available from Biomerix Corporation of Fremont, Calif. which identifies these materials using the trademark BIOMATERIAL™.

Various attachment elements may be used to fix tendon repair implant 50 to distal tendon 28 without deviating from the spirit and scope of this detailed description. Examples of attachment elements that may be suitable in some applications include sutures, tissue anchors, bone anchors, and staples. In the exemplary embodiment of FIG. 6, a plurality of staples 100 are fixing tendon repair implant 50 to distal tendon 28. In some exemplary methods, a plurality of staples 100 may be applied using a fixation tool. The fixation tool may then be withdrawn from the body of the patient. Distal tendon 28 meets humerus 14 at an insertion point 30. With reference to FIG. 6, it will be appreciated that sheet-like implant 50 extends over insertion point 30. Tendon repair implant may be applied to distal tendon 28, for example, using the procedure illustrated in the previous Figure.

FIG. 7A, FIG. 7B, and FIG. 7C are multiple plan views illustrating an exemplary staple 100 in accordance with the present detailed description. FIG. 7A, FIG. 7B, and FIG. 7C may be collectively referred to as FIG. 7. A proximal direction is illustrated with an arrow P in FIG. 7. A distal direction is illustrated with a second arrow D in FIG. 7.

Staple 100 comprises a first arm 102A, a second arm 102B, and a bridge 104 extending from the proximal end of first arm

102A to the proximal end of second arm 102B. The distal end of first arm 102A abuts the proximal end of a first fluke 106A. Similarly, the distal end of second arm 102B abuts the proximal end of a second fluke 106B. In FIG. 7, first fluke 106A and second fluke 106B are shown extending distally from first arm 102A and second arm 102B, respectively. With reference to FIG. 7, it will be appreciated that first fluke 106A has a lateral extent that is larger than a lateral extent of first arm 102A. First fluke 106A is mounted eccentrically to first arm 102A in the embodiment of FIG. 7. Second fluke 106B is mounted eccentrically to second arm 102B and second fluke 106B has a lateral extent that is larger than a lateral extent of second arm 102B. First fluke 106A includes a first proximal surface 108A projecting at an outward angle in a proximal direction away from the distal end of first arm 102A. Second fluke 106B includes a second proximal surface 108B projecting at an outward angle in a proximal direction away from the distal end of second arm 102B.

With reference to FIG. 7A, it will be appreciated that first fluke 106A includes a first point 120A and a first barb 122A. Second fluke 106B includes a second point 120B and a second barb 122B. In FIG. 7, first point 120A and second point 120B are shown generally pointing in the distal direction indicated by arrow D. Also in FIG. 7, first barb 122A and second barb 122B are shown generally pointing in the proximal direction indicated by arrow P.

With reference to FIG. 7A it will be appreciated that first fluke 106A defines a first passageway 124A and second fluke 106B defines a second passageway 124B. In the exemplary embodiment of FIG. 7, first passageway 124A extends through first fluke 106A and second passageway 124B extends through second fluke 106B. It will be appreciated, however, that first passageway 124A may extend through other portions of staple 100 in some embodiments. Similarly, second passageway 124B may extend through other portions of staple 100 in some embodiments. With reference to FIG. 7B it will be appreciated that, first passageway 124A and second passageway 124B each have a generally square cross-sectional shape. It will be appreciated, however, that first passageway 124A and second passageway 124B may have various cross-sectional shapes without deviating from the spirit and scope of the present detailed description. Further, each passageway can extend partially through the length of each fluke rather than all the way through to provide a cavity rather than a passageway.

With reference to FIG. 7C, it will be appreciated that first barb 122A of first fluke 106A defines a first notch 126A. In the exemplary embodiment of FIG. 7, first notch 126A divides first barb 122A into a first sub-barb and a second sub-barb. Second barb 122B of second fluke 106B defines a second notch 126B. In the exemplary embodiment of FIG. 7, second notch 126B divides second barb 122B into a first sub-barb and a second sub-barb.

FIG. 8 is a perspective view showing staple 100 shown in the previous Figure. Staple 100 comprises a first arm 102A, a second arm 102B, and a bridge 104 extending from the proximal end of first arm 102A to the proximal end of second arm 102B. The distal end of first arm 102A abuts the proximal end of a first fluke 106A. With reference to FIG. 8 it will be appreciated that first fluke 106A defines a first passageway 124A. In the exemplary embodiment of FIG. 8, first passageway 124A has a generally square cross-sectional shape. It will be appreciated, however, that first passageway 124A may have various cross-sectional shapes without deviating from the spirit and scope of the present detailed description.

A second fluke 106B extends distally from second arm 102B with the proximal end of second fluke 106B abutting the

11

distal end of second arm 102B. With reference to FIG. 8, it will be appreciated that second fluke 106B has a lateral extent that is larger than a lateral extent of second arm 102B. Second fluke 106B is mounted eccentrically to second arm 102B in the embodiment of FIG. 8. Similarly, first fluke 106A is mounted eccentrically to first arm 102A and first fluke 106A has a lateral extent that is larger than a lateral extent of first arm 102A.

A proximal direction is illustrated with an arrow P in FIG. 8. A distal direction is illustrated with a second arrow D in FIG. 8. With reference to FIG. 8A, it will be appreciated that first fluke 106A of first arm 102A includes a first point 120A and a first barb 122A. Second fluke 106B includes a second point 120B and a second barb 122B. In FIG. 8, first point 120A and second point 120B are shown generally pointing in the distal direction indicated by arrow D. Also in FIG. 8, first barb 122A and second barb 122B are shown generally pointing in the proximal direction indicated by arrow P. With reference to FIG. 8, it will be appreciated that first fluke 106A includes a first proximal surface 108A projecting at an outward angle in a proximal direction away from the distal end of first arm 102A. Second fluke 106B includes a second proximal surface 108B projecting at an outward angle in a proximal direction away from the distal end of second arm 102B.

FIG. 9 is a perspective view showing a staple push rod 130 that may be used in conjunction with staple 100 shown in the previous Figure. Staple push rod 130 includes a shaft 132 and a pair of stakes 134 extending distally beyond a distal end of shaft 132. The distal direction is indicated with an arrow D in FIG. 9. Stakes 134 include a first stake 134A and a second stake 134B. First stake 134A and second stake 134B form a fork 136.

In the embodiment of FIG. 9, each stake 134 has a distal portion 138 and a proximal portion 140. In some useful embodiments, each distal portion 138 is dimensioned to extend into a passage defined by a staple. In the embodiment of FIG. 9, each proximal portion 140 has a width larger than a width of each distal portion 138 so that a shoulder of each proximal portion 140 contacts a proximal surface of the staple to apply pushing forces thereto. First stake 134A comprises a first shoulder 142A and second stake 134B comprises a second shoulder 142B. Although depicted as a shoulder to provide pushing force to the staple, other designs can be utilized. For example, any larger cross section proximal portion can provide a pushing force, such as a conical increase in profile. In the embodiment of FIG. 9, proximal portion 140 of first stake 134A and the proximal portion 140 of second stake 134B diverge from one another as they extend in distal direction D away from shaft 132. In some applications, this arrangement may cause pushing forces applied to two flukes of a staple to have a laterally outward component.

In FIG. 9, first stake 134A and second stake 134B are shown assuming a substantially unstressed state. It will be appreciated that first stake 134A and second stake 134B can be resiliently urged to assume shapes other than the shape shown in FIG. 9. For example, first stake 134A and second stake 134B may be urged together so that fork 136 can be inserted into a lumen having a diameter smaller than the distance between the distal points of first stake 134A and second stake 134B shown in FIG. 9.

FIG. 10A and FIG. 10B illustrate multiple plan views of an exemplary fixation tool 144 in accordance with the present detailed description. Fixation tool 144 incorporates staple push rod 130 and is useful in delivering staple 100. FIG. 10A and FIG. 10B may be referred to collectively as FIG. 10. It is customary to refer to multi-view projections using terms such as front view, top view, and side view. In accordance with this

12

convention, FIG. 10A may be referred to as a top view of fixation tool 144 and FIG. 10B may be referred to as a side view of fixation tool 144. The terms top view and side view are used herein as a convenient method for differentiating between the views shown in FIG. 10. It will be appreciated that the elements shown in FIG. 10 may assume various orientations without deviating from the spirit and scope of this detailed description. Accordingly, the terms top view and side view should not be interpreted to limit the scope of the invention recited in the attached claims.

In the embodiment of FIG. 10, fixation tool 144 comprises a pilot member or fixation tool shaft 146 that is attached to a handle 148. Fixation tool shaft 146 comprises a wall 150 defining a lumen 152. With reference to FIG. 10, it will be appreciated that fixation tool shaft 146 includes a first prong 154A and a second prong 156B that extend distally beyond a distal end 158 of lumen 152.

In FIG. 10, a staple 100 can be seen residing in lumen 152 of fixation tool shaft 146. For purposes of illustration, a distal portion of fixation tool shaft 146 is enlarged in FIG. 10 to better show staple 100. Staple 100 comprises a first arm 102A, a second arm 102B, and a bridge 104 extending from the proximal end of first arm 102A to the proximal end of second arm 102B. The distal end of first arm 102A abuts the proximal end of a first fluke 106A. Similarly, the distal end of second arm 102B abuts the proximal end of a second fluke 106B. In FIG. 10, first fluke 106A and second fluke 106B are shown extending distally from first arm 102A and second arm 102B, respectively.

Staple push rod 130 includes a shaft 132 and a pair of stakes 134 extending distally beyond a distal end of shaft 132. The distal direction is indicated with an arrow D in FIG. 10. Stakes 134 include a first stake 134A and a second stake 134B. In FIG. 10, a distal portion of each stake 134 can be seen extending through a passageway defined by staple 100. In the embodiment of FIG. 10, a trigger 160 is pivotably coupled to handle 148 of fixation tool 144. Trigger 160 is operatively coupled to staple push rod 130. In operation, staple push rod 130 will be advanced and/or retracted in an axial direction when trigger 160 is pivoted relative to handle 148.

FIG. 11A is a further enlarged top view of a distal portion of fixation tool shaft 146 shown in the previous Figure. For purposes of illustration, fixation tool shaft 146 is shown in partial cross-section in FIG. 11A so that staple 100 is visible residing in lumen 152. With reference to FIG. 11A, it will be appreciated that staple 100 is disposed on a distal portion of staple push rod 130. Staple 100 comprises a first arm 102A, a second arm 102B, and a bridge 104 extending from the proximal end of first arm 102A to the proximal end of second arm 102B. The distal end of first arm 102A abuts the proximal end of a first fluke 106A. Similarly, the distal end of second arm 102B abuts the proximal end of a second fluke 106B. In FIG. 11, first fluke 106A and second fluke 106B are shown extending distally from first arm 102A and second arm 102B, respectively.

First fluke 106A of staple 100 defines a first passageway 124A. In FIG. 11A, a distal portion 138 of first stake 134A of staple push rod 130 can be seen extending through first passageway 124A defined by first fluke 106A. A distal portion 138 of second stake 134B of staple push rod 130 can be seen extending through a second passageway 124B defined by second fluke 106B of staple 100.

In FIG. 11A, a first shoulder 142A of first stake 134A is shown contacting proximal surface 108 of first fluke. Distal portion 138 of first stake 134A extends distally of first shoulder 142A and proximal portion 140 of first stake 134A extends proximally of first shoulder 142A. In some useful

13

embodiments, the proximal portion of first stake **134A** has a first thickness and the distal portion of first stake **134A** has a second thickness different from the first thickness. In some particularly useful embodiments, the second thickness is less than the first thickness. In some applications, this may increase the flexibility of the distal portion of first stake **134A** so that it bends more easily, and so that it withdraws from the staple with minimal force.

A second shoulder **142B** of second stake **134B** is shown contacting proximal surface **108** of second fluke **106** in FIG. **11A**. A distal portion **138** of second stake **134B** extends distally of second shoulder **142B** and a proximal portion **140** of second stake **134B** extends proximally of second shoulder **142B**. In some useful embodiments, the proximal portion of second stake **134B** has a first thickness and the distal portion of second stake **134B** has a second thickness different from the first thickness. In some particularly useful embodiments, the second thickness is less than the first thickness. In some applications, this may increase the flexibility of the distal portion of first stake **134A** so that it bends more easily, and so that it withdraws from the staple with minimal force.

With reference to FIG. **11A**, it will be appreciated that there is a gap **G** between staple push rod **130** and bridge **104** of staple **100**. In some applications, gap **G** allows staple **100** to be placed in tension without bridge **104** contacting staple push rod **130**. Staple **100** may be placed in tension, for example, as staple **100** is advanced into a target tissue.

FIG. **11B** is an additional top view showing a distal portion of fixation tool shaft **146**, staple push rod **130**, and staple **100**. By comparing FIG. **11A** and FIG. **11B**, it will be appreciated that staple push rod **130** and staple **100** have been advanced in a distal direction **D** relative to fixation tool shaft **146**. In FIG. **11B**, staple **100** is shown extending out of lumen **152** defined by fixation tool shaft **146**.

In FIG. **11B**, a distal portion **138** of first stake **134A** of staple push rod **130** can be seen extending through a first passageway **124A** defined by first fluke **106A** of staple **100**. In FIG. **11B**, a first shoulder **142A** of first stake **134A** is shown contacting proximal surface **108** of first fluke **106A**. Distal portion **138** of first stake **134A** extends distally of first shoulder **142A** and proximal portion **140** of first stake **134A** extends proximally of first shoulder **142A**. In some useful embodiments, the proximal portion of first stake **134A** has a first width and the distal portion of first stake **134A** has a second width different from the first width. In some particularly useful embodiments, the first width is greater than the first width. The arrangement allows the proximal portion of stake to engage a proximal surface of the staple to apply pushing forces to the staple.

In FIG. **11B**, a distal portion **138** of second stake **134B** of staple push rod **130** can be seen extending through a second passageway **124B** defined by second fluke **106B** of staple **100**. In FIG. **11B**, a second shoulder **142B** of second stake **134B** is shown contacting proximal surface **108** of second fluke **106B**. In the embodiment of FIG. **11B**, proximal portion **140** of second stake **134B** may apply pushing force to proximal surface **108** of second stake **134B**. Proximal portion **140** of second stake **134B** extends proximally of second shoulder **142B** and distal portion **138** of second stake **134B** extends distally of second shoulder **142B**. In the embodiment of FIG. **11B**, proximal portion **140** of second stake **134B** has a width larger than the width of distal portion **138** of second stake **134B** so that the shoulder **142** of second stake **134B** contacts proximal surface **108** of second fluke **106B** to apply pushing forces thereto.

In the embodiment of FIG. **11B**, first stake **134A** and second stake **134B** are in a substantially unstressed state. It will

14

be appreciated that first stake **134A** and second stake **134B** can be resiliently urged to assume shapes other than the shape shown in FIG. **11**. For example, first stake **134A** and second stake **134B** may be urged together so that fork **136** of staple push rod **130** and staple **100** can be inserted into lumen **152** defined by fixation tool shaft **146**.

With reference to FIG. **11B**, it will be appreciated that there is a gap **G** between staple push rod **130** and bridge **104** of staple **100**. In some applications, gap **G** allows staple **100** to be placed in tension without bridge **104** contacting staple push rod **130**. In some applications, placing staple **100** under tension may urge first fluke **106** and second fluke **106** into orientations which lock staple **100** into a target tissue. For example, first fluke **106A** and second fluke **106B** may be rotated so that a barb of each fluke engages the target tissue. When this is the case, the tension on the staple may keep first fluke **106A** and second fluke **106B** in the rotated position. Also when this is the case, the barbs of the rotated flukes may inhibit staple pullout.

FIG. **12A** through FIG. **12C** are a sequence of plan views illustrating an exemplary method in accordance with the present detailed description. FIG. **12A**, FIG. **12B**, and FIG. **12C** may be collectively referred to as FIG. **12**. The exemplary method illustrated in FIG. **12** may be used, for example, to fix a tendon repair implant **50** to a target tissue **T** using a staple **100**.

At FIG. **12A**, a fixation tool **144** has been used to form a first pilot hole **162A** and a second pilot hole **162B** in target tissue **T**. In the embodiment of FIG. **12**, fixation tool **144** includes a fixation tool shaft **146** comprising a wall **150** defining a lumen **152**. With reference to FIG. **12**, it will be appreciated that fixation tool shaft **146** includes a first prong **154A** and a second prong **156B** that extend distally beyond a distal end **158** of lumen **152**. In the embodiment of FIG. **12A**, first prong **154A** and second prong **156B** have been urged into tissue **T** to form first pilot hole **162A** and second pilot hole **162B**. In FIG. **12A** a distally directed force **F** applied to fixation tool shaft **146** is illustrated using an arrow. Force **F** may be produced, for example, by pushing on a handle that is fixed to a proximal portion of fixation tool shaft **146**. It will be appreciated that in some embodiments, such as the embodiment depicted in FIG. **6**, one of the first and second pilot holes may be formed through the sheet-like implant and the target tissue, and the other pilot hole may be formed directly in the target tissue without passing through the sheet-like implant. In other words, in various embodiments staples may straddle the perimeter edge of the sheet-like implant (as shown in FIG. **6**), may be applied adjacent to the perimeter, and/or be applied to a central region of the implant. In some embodiments, the staples may be used to attach the implant to soft tissue and/or to bone. In FIG. **12A**, a staple **100** can be seen residing in lumen **152** of fixation tool shaft **146**. For purposes of illustration, fixation tool shaft **146** is shown in partial cross-section in FIG. **12A** so that staple **100** is visible residing in lumen **152**. With reference to FIG. **12**, it will be appreciated that staple **100** is carried by a fork **136** comprising a first stake **134A** and a second stake **134B**. In FIG. **12A**, a distal portion of first stake **134A** of staple push rod **130** can be seen extending through a first passageway defined by first fluke **106A**. A distal portion of second stake **134B** of staple push rod **130** can be seen extending through a second passageway defined by second fluke **106B** of staple **100**.

In some useful embodiments, each stake is positioned relative to a prong along an inner surface of fixation tool shaft **146** so that the stakes advance into the pilot holes when the stakes are moved in a distal direction. Staple push rod **130** is slidably disposed within lumen **152** defined by along fixation tool

15

shaft 146. Fixation tool 144 includes a mechanism that is capable of creating relative axial motion between staple push rod 130 and fixation tool shaft 146 so that staple push rod 130 slides along fixation tool shaft 146.

At FIG. 12B, relative motion has been created between staple push rod 130 and fixation tool shaft 146 while distally directed force F has been continuously applied to fixation tool shaft 146. By comparing FIG. 12B and FIG. 12A, it will be appreciated that first stake 134A and second stake 134B have been advanced in a distal direction D. With reference to FIG. 12, it will also be appreciated that first stake 134A and second stake 134B have advanced into first pilot hole 162A and second pilot hole 162B, respectively. In FIG. 12B, first fluke 106A is shown residing in first pilot hole 162. Second fluke 106B is residing in second pilot hole 162 in the embodiment of FIG. 12B.

At FIG. 12C, additional relative motion has been created between staple push rod 130 and fixation tool shaft 146 while distally directed force F has been continuously applied to fixation tool shaft 146. By comparing FIG. 12C and FIG. 12B, it will be appreciated that the relative motion between staple push rod 130 and fixation tool shaft 146 has moved fixation tool shaft 146 in a proximal direction P.

By comparing FIG. 12C and FIG. 12B, it will also be appreciated that first arm 102A of staple 100 has been bent and first fluke 106A has been rotated to a toggled position. In the exemplary embodiment of FIG. 12C, force applied to first fluke 106A by first shoulder 142A has caused first fluke 106A to rotate. Also in the embodiment of FIG. 12C, the rotation of first fluke 106A has caused some bending in the distal portion 138 of first stake 134A. With continuing reference to FIG. 12C and FIG. 12B, it will be appreciated that second arm 102B of staple 100 has been bent and second fluke 106A has been rotated to a toggled position. In the exemplary embodiment of FIG. 12C, force applied to second fluke 106B by second shoulder 142B has caused second fluke 106B to rotate. Also in the embodiment of FIG. 12C, the rotation of second fluke 106B has caused some bending in the distal portion 138 of second stake 134B.

With reference to FIG. 12C, it will be appreciated that a first through hole 164A and a second through hole 164B have been formed in tendon repair implant 50. In the embodiment of FIG. 12, first through hole 164A and a second through hole 164B were created by urging first prong 154A and second prong 156B of fixation tool shaft 146 through tendon repair implant 50.

FIG. 13A, FIG. 13B, and FIG. 13C are multiview projections illustrating a fixation tool shaft 146 shown in the previous Figures. FIG. 13D is a cross-sectional view of fixation tool shaft 146 sectioned along cutting plane D-D illustrated in FIG. 13C. These Figures may be collectively referred to as FIG. 13. Fixation tool shaft 146 of FIG. 13 comprises a wall 150 defining a lumen 152. A first prong 154A and a second prong 156B of fixation tool shaft 146 extend distally beyond a distal end 158 of lumen 152.

With reference to FIG. 13, it will be appreciated that fixation tool shaft 146 comprises a proximal portion 170, a distal portion 168 and an intermediate portion 166 disposed between proximal portion 170 and distal portion 168. In the embodiment of FIG. 13, distal portion 168 has an axial extent DA, a major lateral extent LA and a minor lateral extent LB. With reference to FIG. 13, it will be appreciated that axial extent DA is greater than both minor lateral extent LB and major lateral extent LA.

FIG. 14 is an enlarged axial view of fixation tool shaft 146 shown in the previous Figure. With reference to FIG. 14, it will be appreciated that proximal portion 170 of fixation tool

16

shaft 146 comprises a wall 150 having an outer surface 172. In FIG. 14, outer surface 172 is illustrated using a circle. Thus, it will be appreciated that proximal portion 170 of fixation tool shaft 146 has a generally cylindrical outer shape in the exemplary embodiment of FIG. 14. In the exemplary embodiment of FIG. 14, fixation tool shaft 146 has a generally uniform wall thickness. Accordingly, the shape of proximal portion 170 may be generally described as a cylindrical tube. The shape of distal portion 168 may be described as a cylindrical-tube that has been partially flattened. In the exemplary embodiment of FIG. 14, distal portion 168 of fixation tool shaft 146 has a major lateral extent LA and a minor lateral extent LB. With reference to FIG. 14, it will be appreciated that major lateral extent LA is greater than minor lateral extent LB.

FIG. 15 is an additional enlarged axial view of fixation tool shaft 146. With reference to FIG. 15, it will be appreciated that distal portion 168 of fixation tool shaft 146 comprises a first major side SA, a second major side SB, a first minor side SC, and a second minor side SD. In the exemplary embodiment of FIG. 15, each minor side has a first central radius RA and each major side has a second central radius RB. With reference to FIG. 15, it will be appreciated that second central radius RB is greater than first central radius RA. In the exemplary embodiment of FIG. 15, first major side SA, second major side SB, first minor side SC, and second minor side SD each have a generally convex shape. In the exemplary embodiment of FIG. 15, each minor side is generally more convex than each major side.

FIG. 16 is an exploded isometric view of an exemplary fixation tool 144 in accordance with this detailed description. In the embodiment of FIG. 16, fixation tool 144 comprises a fixation tool shaft 146 and a handle 148. In FIG. 16, handle 148 is exploded into two pieces. A proximal portion of fixation tool shaft 146 is fixed to handle 148 when fixation tool 144 is in an assembled state. Fixation tool shaft 146 comprises a wall 150 defining a lumen 152. With reference to FIG. 16, it will be appreciated that fixation tool shaft 146 includes a first prong 154A and a second prong 156B that extend distally beyond a distal end 158 of lumen 152.

When fixation tool 144 is in an assembled state a staple push rod 130 extends into lumen 152 of fixation tool shaft 146. Staple push rod 130 comprises a fork 136 and a shaft 132. Fork 136 comprises a first stake 134A and a second stake 134B. Shaft 132 is coupled between fork 136 and a lever 174. Lever 174 is coupled to a trigger 160. Trigger 160 is pivotably coupled to handle 148 of fixation tool 144 when fixation tool 144 is in an assembled state. In operation, staple push rod 130 will be advanced and/or retracted in an axial direction when trigger 160 is pivoted relative to handle 148.

While exemplary embodiments of the present invention have been shown and described, modifications may be made, and it is therefore intended in the appended claims and subsequently filed claims to cover all such changes and modifications which fall within the true spirit and scope of the invention.

What is claimed is:

1. A method for attaching a sheet-like implant to a target tissue, comprising the steps of:
 - a. piercing the target tissue with a first prong and a second prong of a pilot member of a device to create a first pilot hole and a second pilot hole, the pilot member of the device having a distal end, the first prong and the second prong extending from the distal end of the pilot member, the device further including a staple push rod carrying a staple, the staple having a first leg having a proximal end and a distal end, and a second leg having a proximal end

17

and a distal end with a bridge extending from the proximal end of the first leg to the proximal end of the second leg and staple retention means proximate the distal end of each leg wherein the staple push rod longitudinally engages the staple;

positioning the distal end of the first leg near the first pilot hole and positioning the distal end of the second leg near the second pilot hole;

advancing the staple push rod in a distal direction so that the push rod applies pushing forces to the staple to advance at least a portion of the first leg and the second leg in a distal direction and into the pre-formed pilot holes with the staple retention means engaging the tissue walls of the pilot holes for retention.

2. The method of claim 1, wherein the pushing force is applied to a surface on each leg of the staple proximate its distal end.

3. The method of claim 1, wherein the pushing force has a direction that is generally parallel to a central axis of the first and second pilot holes.

4. The method of claim 1, wherein the legs are advanced into the pilot holes while the prongs are disposed in the pilot holes.

5. The method of claim 1, further comprising the step of moving the pilot member in a proximal direction relative to the target tissue until a distal end of the first prong is located proximal of the first leg and a distal end of the second prong is located proximal of the second leg.

6. The method of claim 5, wherein moving the pilot member in a proximal direction relative to the target tissue comprises producing relative motion between the staple push rod and the pilot member while applying a distally directed force to the pilot member.

7. The method of claim 1, wherein the step of advancing the staple push rod in a distal direction comprises actuating a mechanism that produces relative motion between the staple push rod and the pilot member while applying a distally directed force to the pilot member.

8. A method for attaching a sheet-like implant to a target tissue, comprising the steps of:

piercing the target tissue with a first prong of a pilot member of a device to create a first pilot hole and piercing the target tissue with a second prong of the pilot member of the device to create a second pilot hole,

the pilot member having a distal end, the first prong and the second prong extending from the distal end of the pilot member,

the device further including a staple push rod carrying a staple, the staple comprising a first arm having a proximal end and a distal end, and a second arm having a proximal end and a distal end with a bridge extending from the proximal end of the first arm to the proximal end of the second arm, a first fluke of the staple having a proximal end abutting the distal end of the first arm, and a second fluke of the staple having a proximal end abutting the distal end of the second arm;

the staple push rod of the device including a pair of stakes, each stake having a distal portion and a proximal portion, each distal portion extending into a passage defined by a fluke, each proximal portion having a width larger

18

than a width of each distal portion so that a shoulder of each proximal portion contacts a proximal surface of a fluke;

positioning the first fluke near the first pilot hole and positioning the second fluke near the second pilot hole;

advancing the staple push rod in a distal direction so that the stakes apply pushing forces to the flukes causing the flukes to advance into the pilot holes and causing the first arm, the second arm, and the bridge to be placed in tension, the first arm providing a first reaction force when placed in tension and the second arm providing a second reaction force when placed in tension;

the pushing forces and reaction forces cooperating to produce a moment applied to each fluke, the moment applied to each fluke causing each fluke to rotate so that each fluke assumes a locked position in which the longitudinal axis of each fluke is skewed relative to a longitudinal axis of the pilot member.

9. The method of claim 8, wherein:

a first moment having a first direction is applied to the first fluke;

a second moment having a second direction is applied to the second fluke;

the first direction is different from the second direction.

10. The method of claim 9, wherein the first direction is generally opposite the second direction.

11. The method of claim 9, wherein the first direction is a clockwise direction and the second direction is a counterclockwise direction.

12. The method of claim 8, wherein a first pushing force is applied to the proximal surface of the first fluke at a location that is offset from the first arm.

13. The method of claim 12, wherein the first pushing force has a direction that is generally parallel to a central axis of the first pilot hole.

14. The method of claim 8, wherein the flukes are advanced into the pilot holes while the prongs are disposed in the pilot holes.

15. The method of claim 8, further comprising the step of moving the pilot member in a proximal direction relative to the target tissue until a distal end of the first prong is located proximal of the first fluke and a distal end of the second prong is located proximally of the second fluke.

16. The method of claim 15, wherein moving the pilot member in a proximal direction relative to the target tissue comprises producing relative motion between the staple push rod and the pilot member while applying a distally directed force to the pilot member.

17. The method of claim 15, wherein the first fluke assumes a first locking position and the second fluke assumes a second locking position while a distal end of the first prong is located proximal of the first fluke and a distal end of the second prong is located proximally of the second fluke.

18. The method of claim 8, wherein the step of advancing the staple push rod in a distal direction comprises producing relative motion between the staple push rod and the pilot member while applying a distally directed force to the pilot member.

* * * * *