



US009084595B2

(12) **United States Patent**
Housman

(10) **Patent No.:** **US 9,084,595 B2**
(45) **Date of Patent:** **Jul. 21, 2015**

(54) **BLENDED SHAFT DRIVE**

(75) Inventor: **Mark Edwin Housman**, North Attleborough, MA (US)

(73) Assignee: **SMITH & NEPHEW INC.**, Memphis, TN (US)

(*) Notice: Subject to any disclaimer, the term of this patent is extended or adjusted under 35 U.S.C. 154(b) by 851 days.

(21) Appl. No.: **13/276,920**

(22) Filed: **Oct. 19, 2011**

(65) **Prior Publication Data**

US 2013/0103054 A1 Apr. 25, 2013

(51) **Int. Cl.**

- A61B 17/04* (2006.01)
- A61B 17/88* (2006.01)
- A61B 17/86* (2006.01)
- A61F 2/08* (2006.01)
- A61B 19/00* (2006.01)

(52) **U.S. Cl.**

CPC *A61B 17/0401* (2013.01); *A61B 17/8615* (2013.01); *A61B 17/888* (2013.01); *A61F 2/0811* (2013.01); *A61B 2017/0403* (2013.01); *A61B 2017/0409* (2013.01); *A61B 2017/0414* (2013.01); *A61B 2017/0445* (2013.01); *A61B 2017/0453* (2013.01); *A61B 2019/301* (2013.01); *A61F 2002/0835* (2013.01); *A61F 2002/0852* (2013.01)

(58) **Field of Classification Search**

CPC *A61B 2017/0409*; *A61B 17/8615*; *A61B 17/0401*
USPC 606/232; 411/395, 410; 80/436, 438, 80/439, 441, 460, 461
See application file for complete search history.

(56) **References Cited**

U.S. PATENT DOCUMENTS

3,586,080 A	6/1971	Slany	
4,827,811 A	5/1989	Vickers	
5,139,499 A	8/1992	Small et al.	
5,354,299 A	10/1994	Coleman	
5,359,911 A	11/1994	Kruesi	
5,461,952 A *	10/1995	Goss	81/460
6,016,727 A	1/2000	Morgan	
6,099,529 A	8/2000	Gertzman et al.	
7,188,554 B2	3/2007	Bayham	

(Continued)

FOREIGN PATENT DOCUMENTS

EP 1101459 A2 5/2001

OTHER PUBLICATIONS

International Search Report for PCT/US2012/059780 mailed Feb. 18, 2013.

(Continued)

Primary Examiner — Thomas McEvoy

(74) *Attorney, Agent, or Firm* — Burns & Levinson LLP; Joseph M. Maraia

(57) **ABSTRACT**

A solid, monolithic shaft member has an engagement end. The engagement end has a proximal end a distal end. The proximal end has a first cross-sectional geometry, and the distal end has a second cross-sectional geometry. The first cross-sectional geometry of the proximal end is different from the second cross-sectional geometry of the distal end. The cross-sectional geometry of the distal end transitions to the a cross-sectional geometry of the proximal end along a longitudinal axis of the engagement end of the solid, monolithic shaft member. This transition provides a gradual, blending, continuously transitioning cross-sectional geometry along the entire length of the longitudinal axis of the engagement end of the solid, monolithic shaft member.

21 Claims, 9 Drawing Sheets

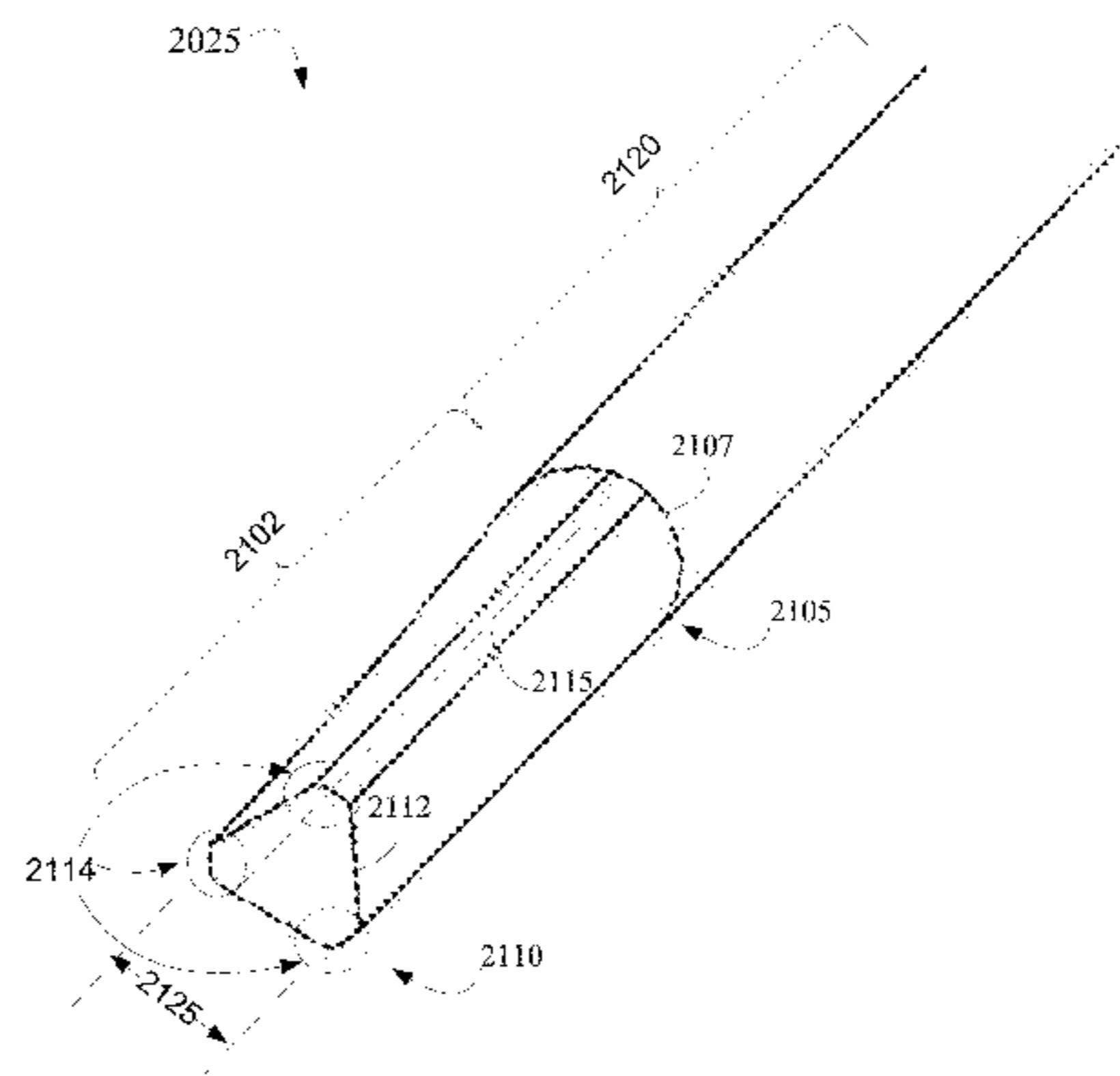
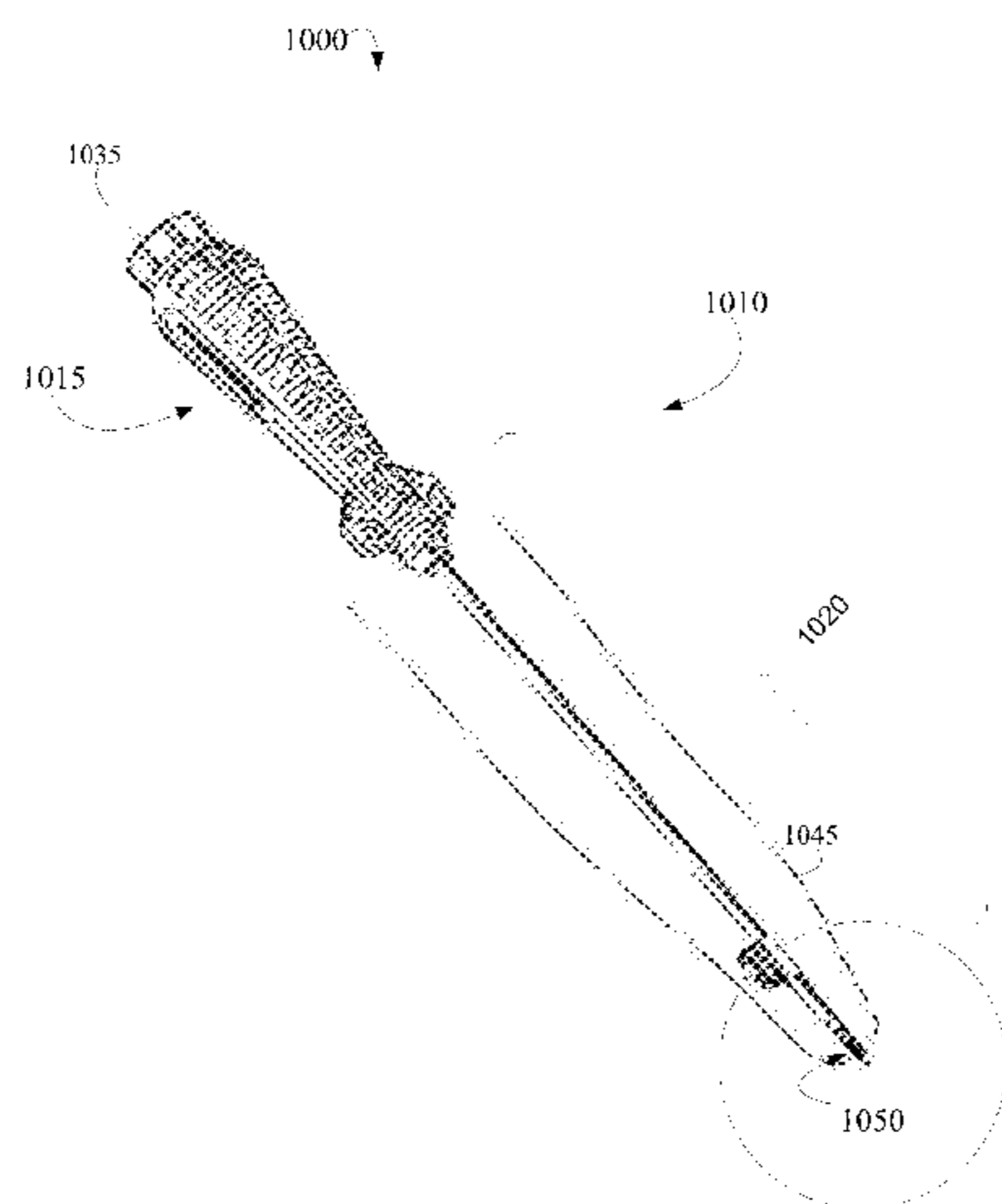

(56)

References Cited

2011/0112576 A1 5/2011 Nguyen et al.

U.S. PATENT DOCUMENTS

7,325,470 B2 2/2008 Kay et al.
7,846,167 B2 12/2010 Garcia
2001/0041937 A1 11/2001 Rieser et al.
2007/0270954 A1 11/2007 Wu
2010/0251861 A1 10/2010 Sixto, Jr. et al.

OTHER PUBLICATIONS

International Preliminary Report on Patentability for PCT/US2012/
059780 mailed Apr. 22, 2014.

* cited by examiner

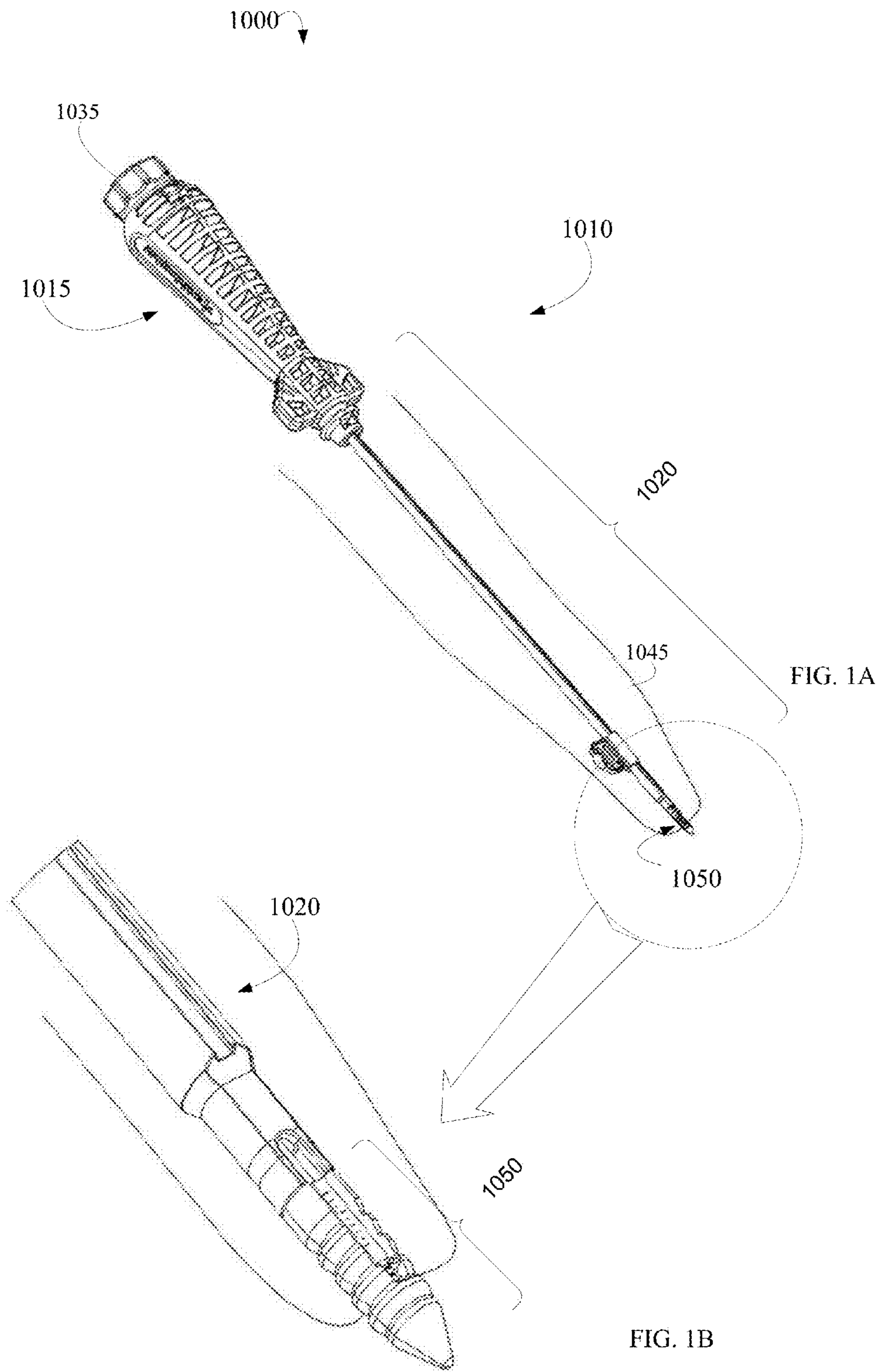

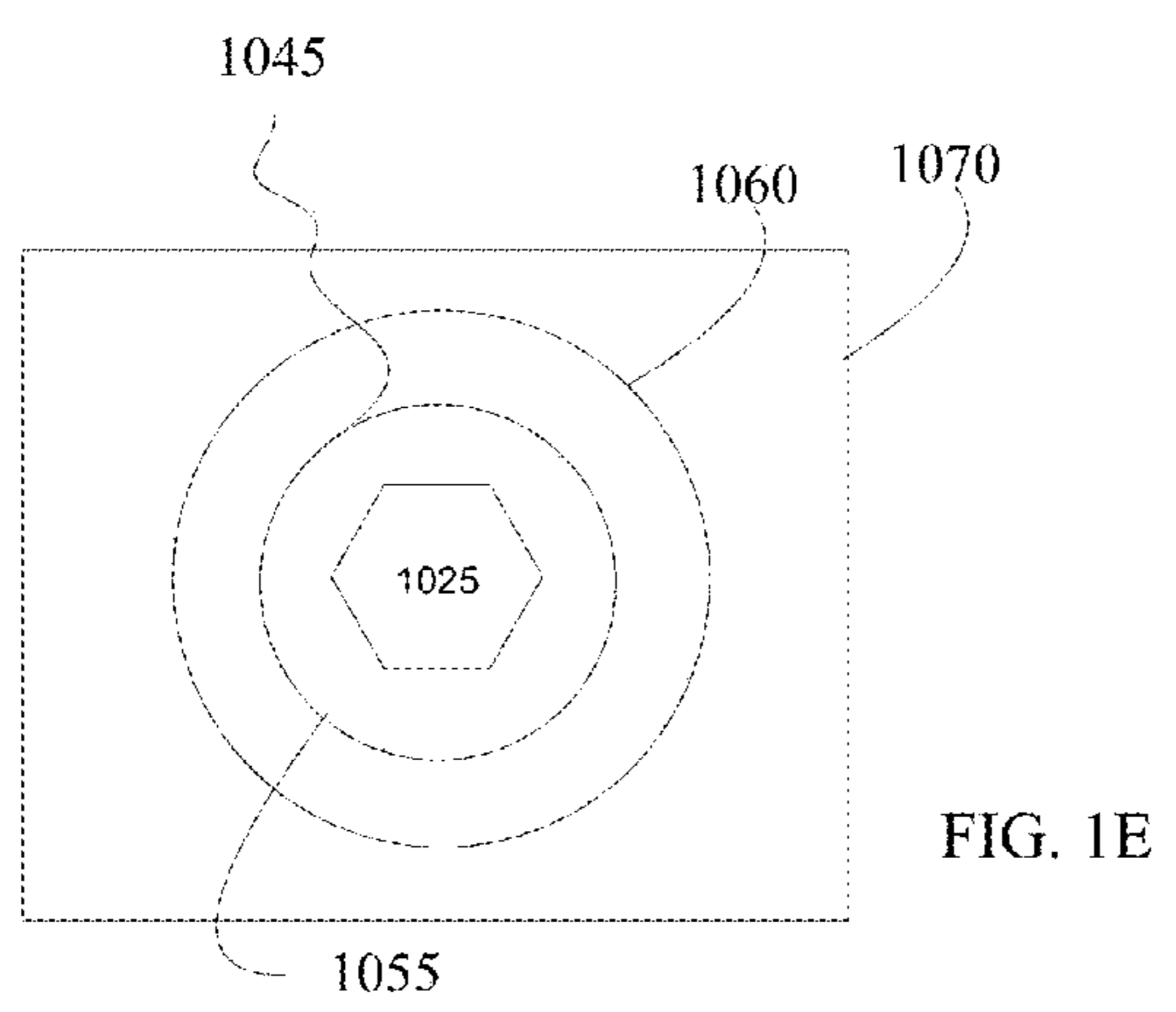
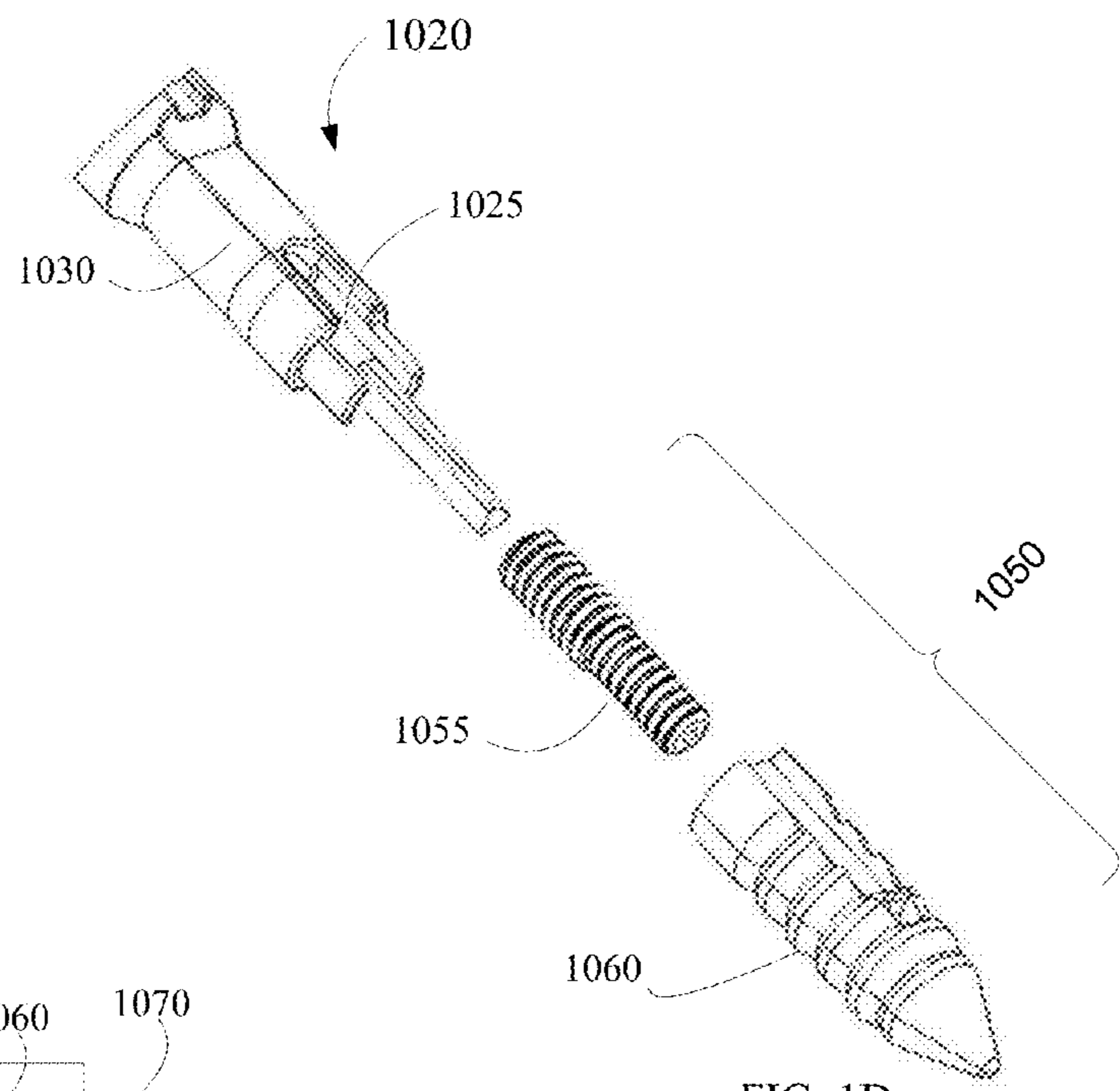
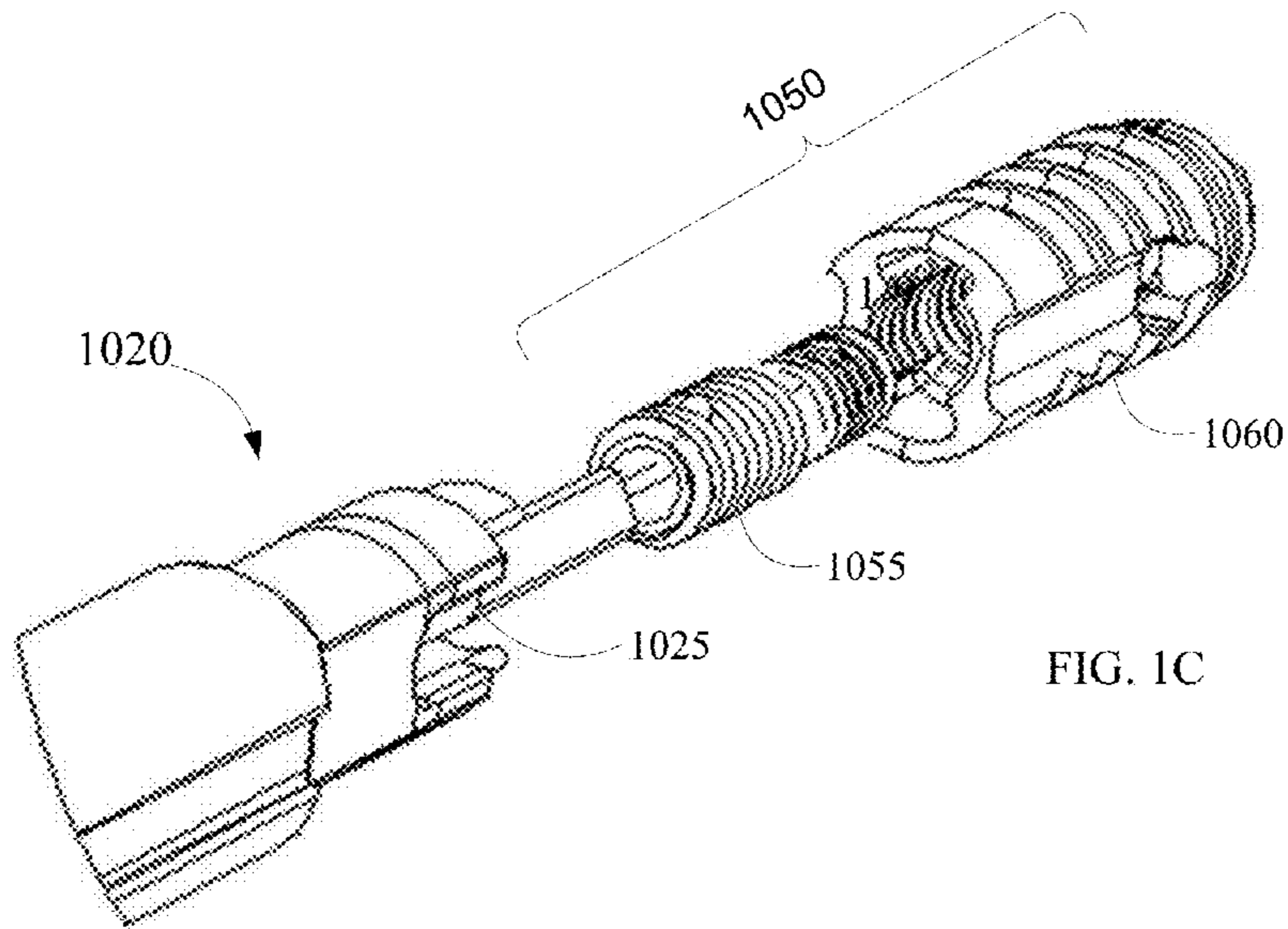

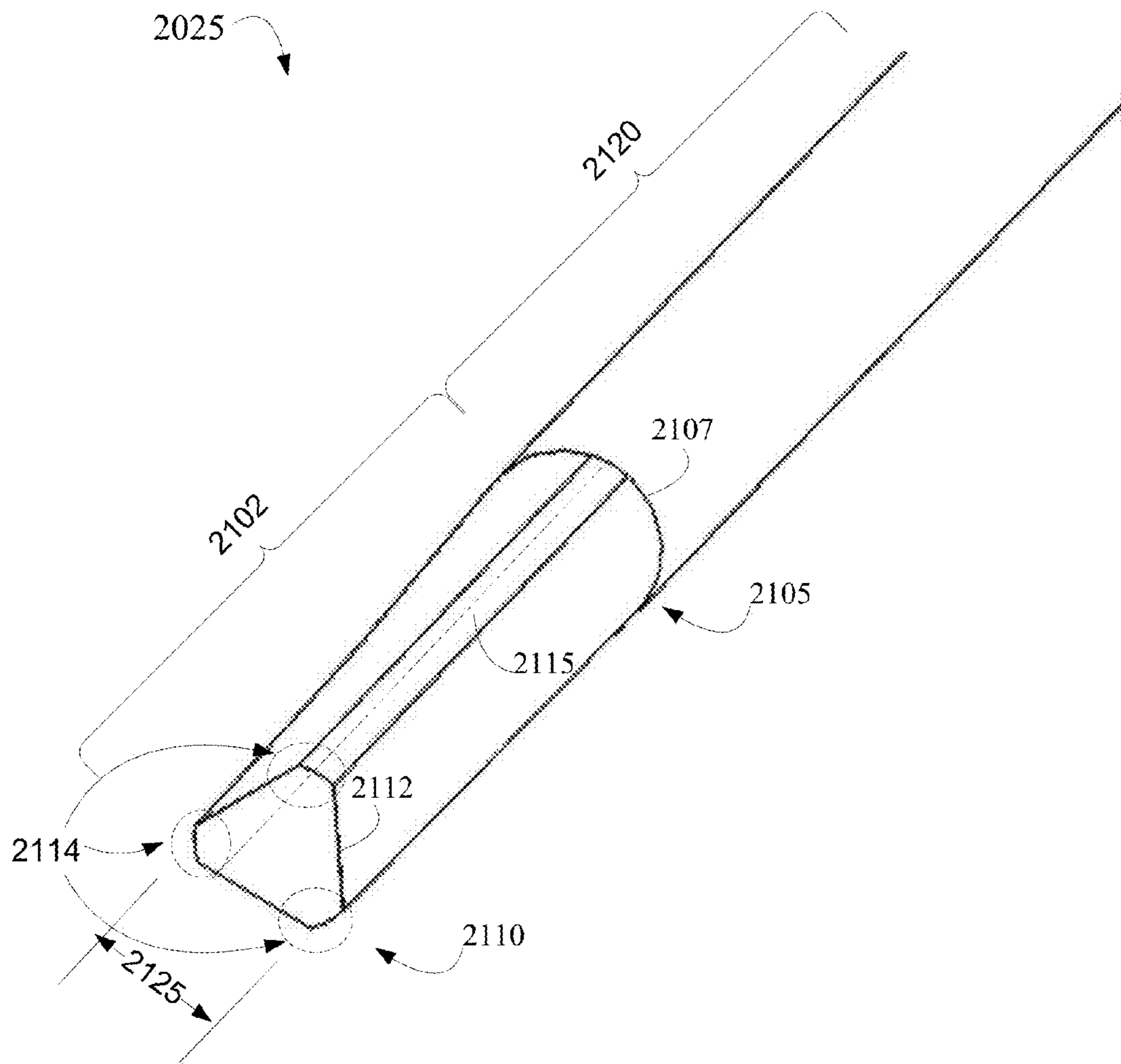

FIG. 2

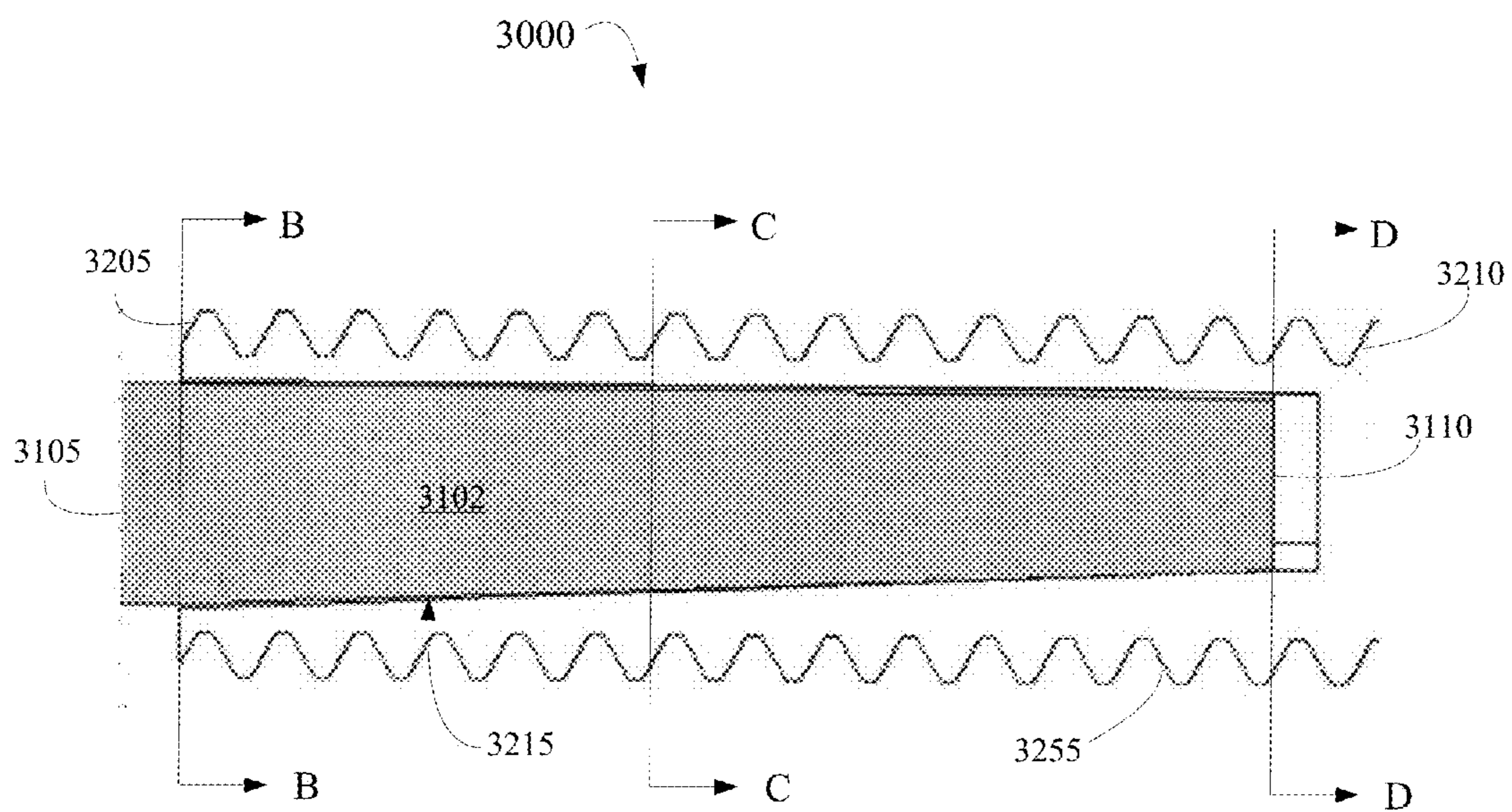

FIG. 3A

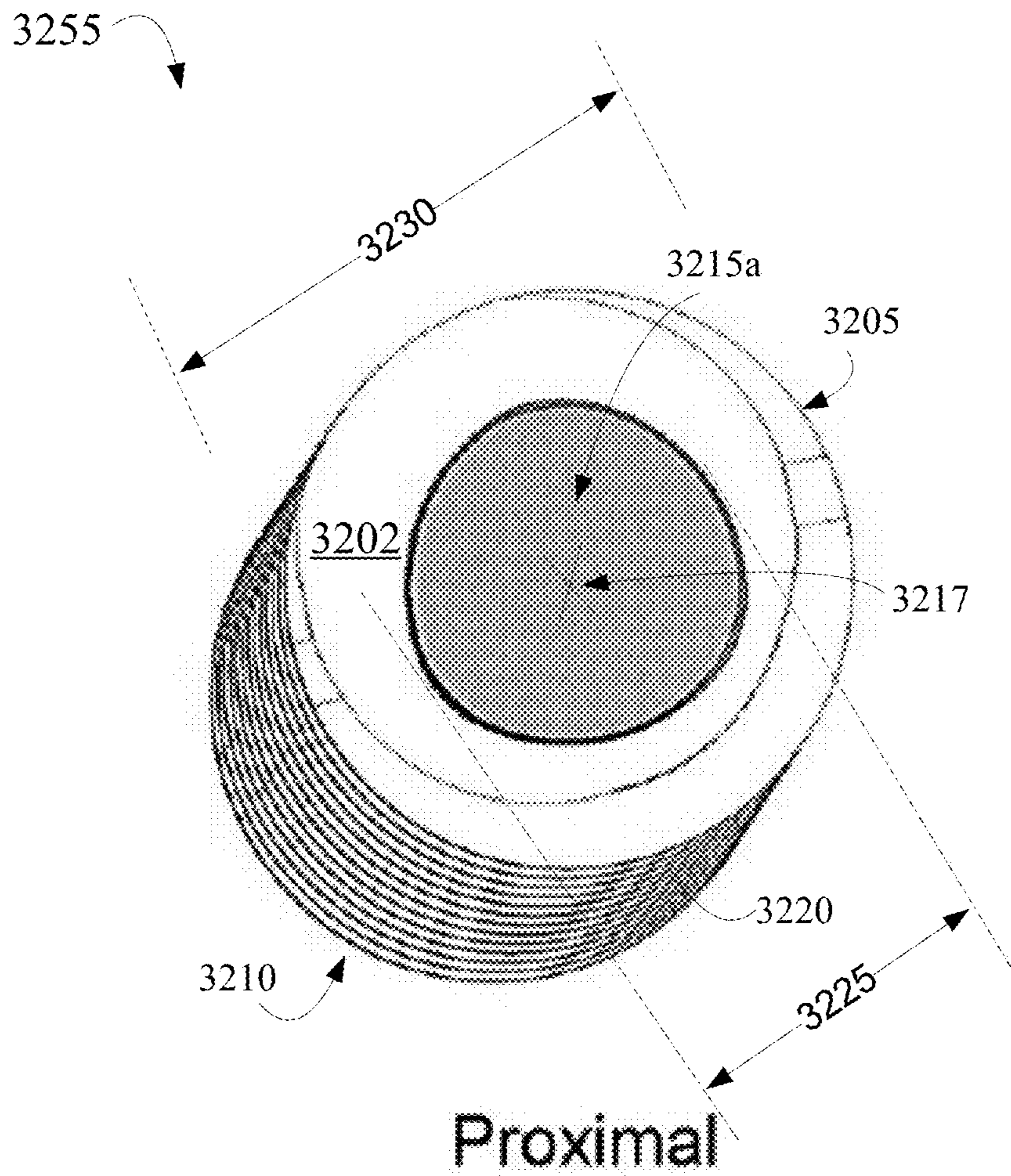
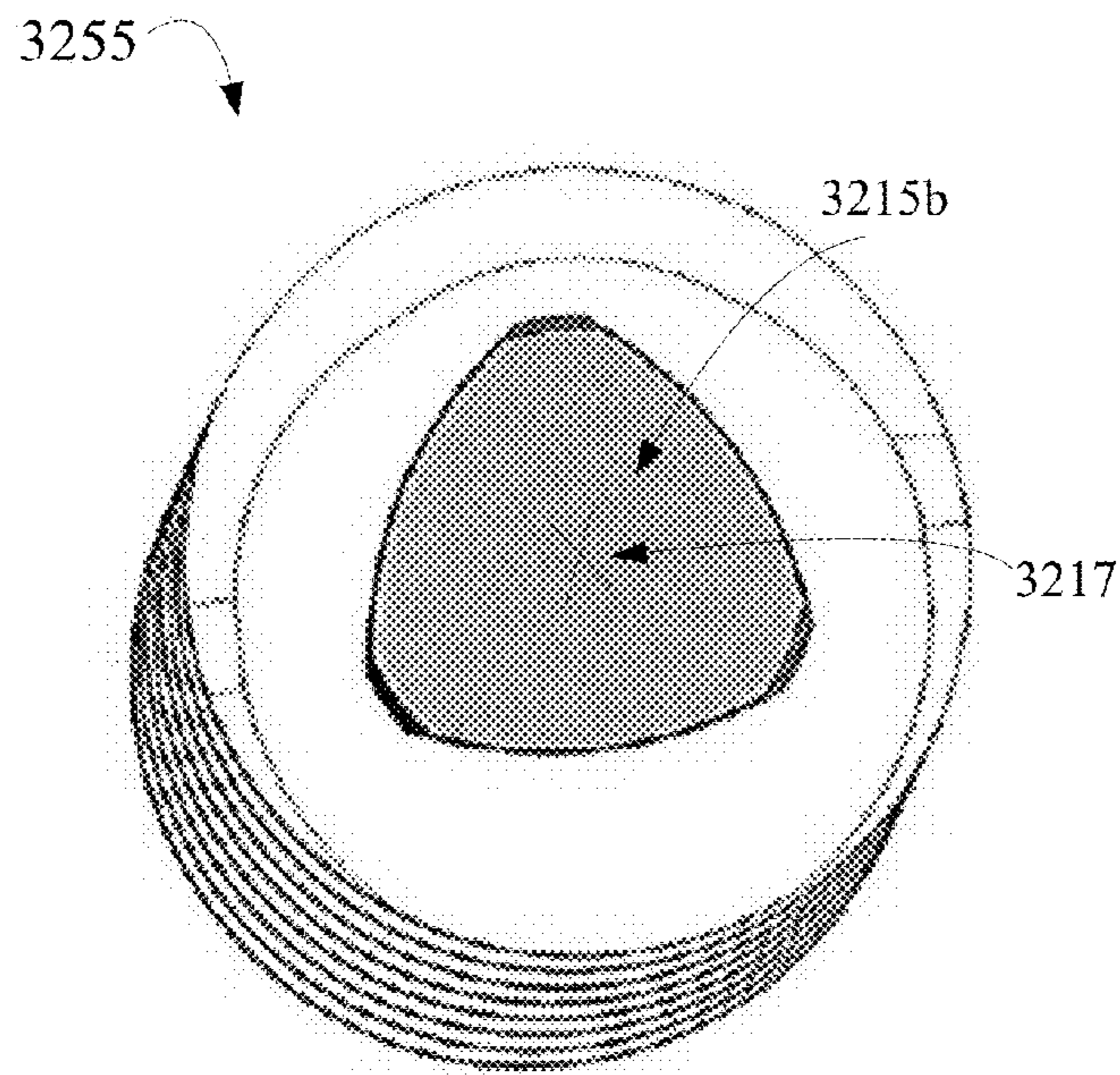
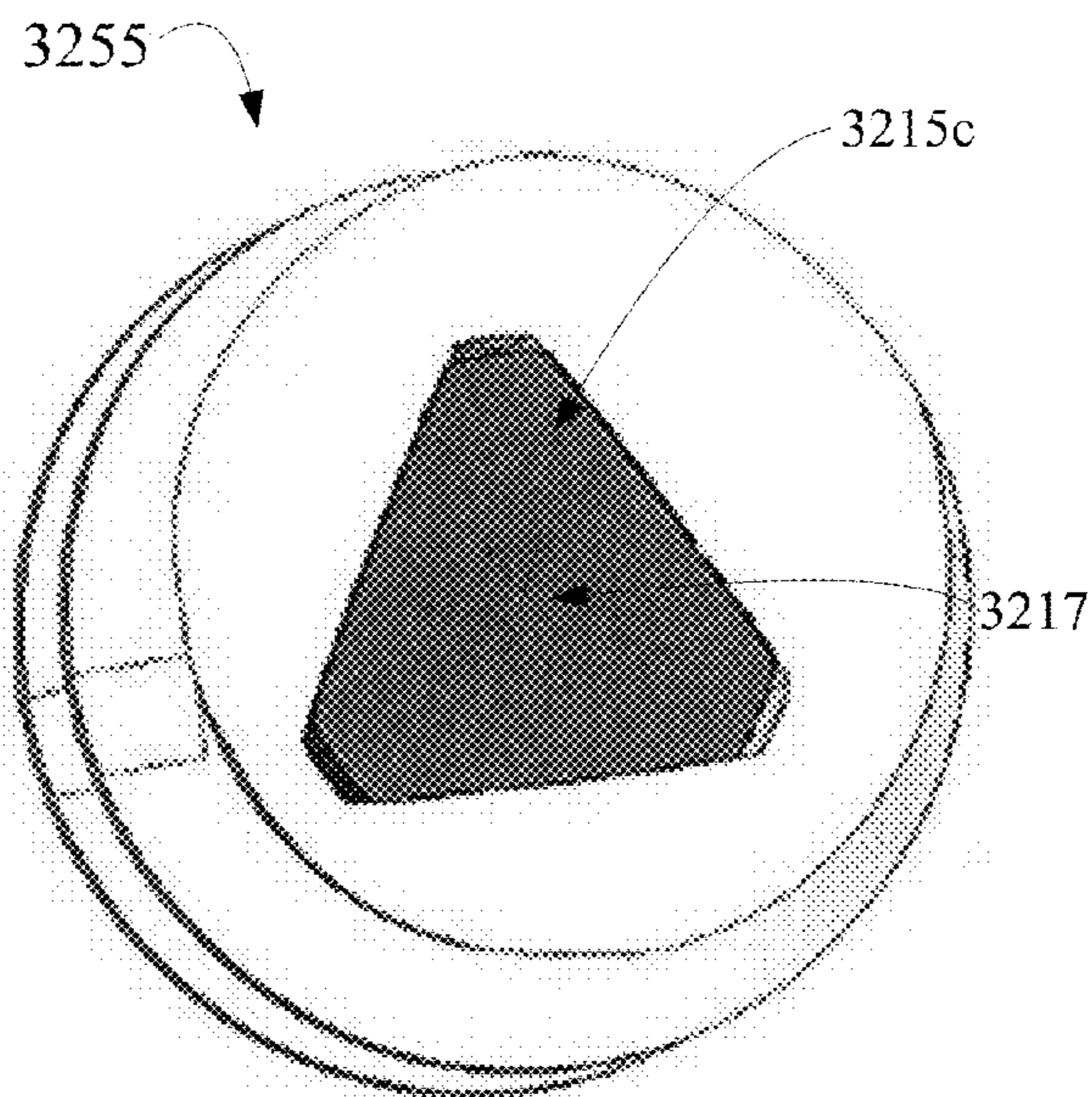

FIG. 3B



Midway

FIG. 3C



Distal

FIG. 3D

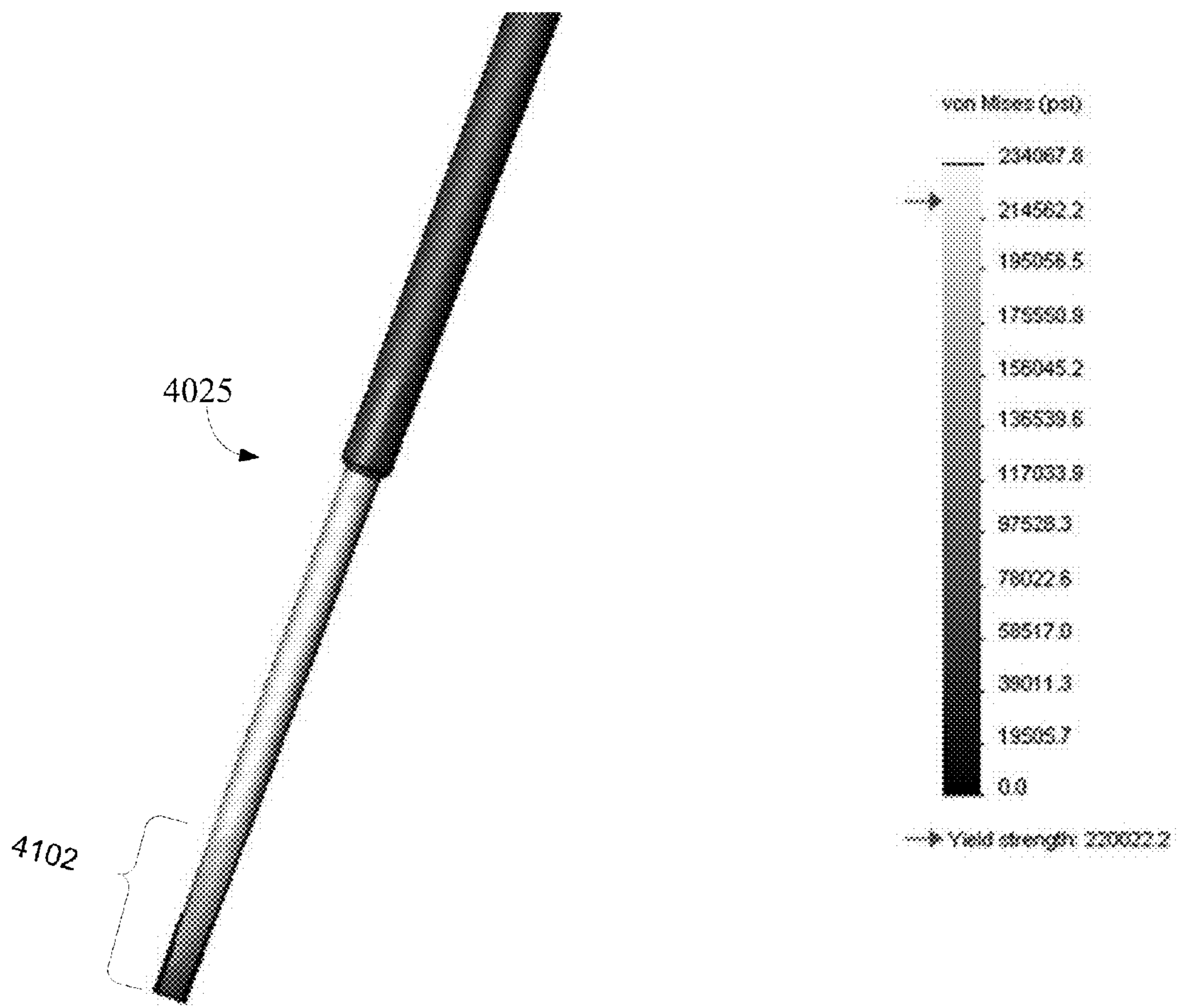
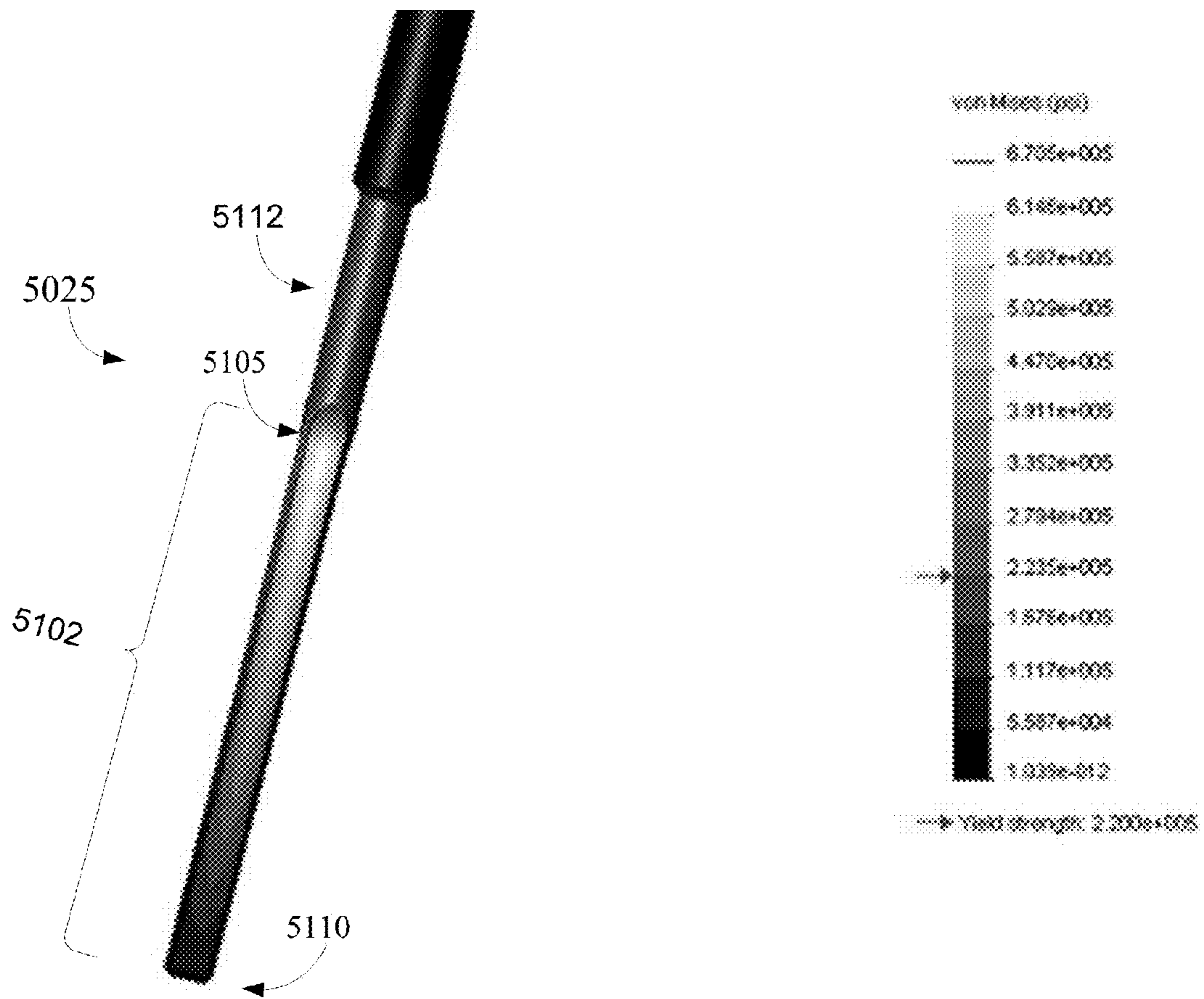

FIG. 4



PRIOR ART

FIG. 5

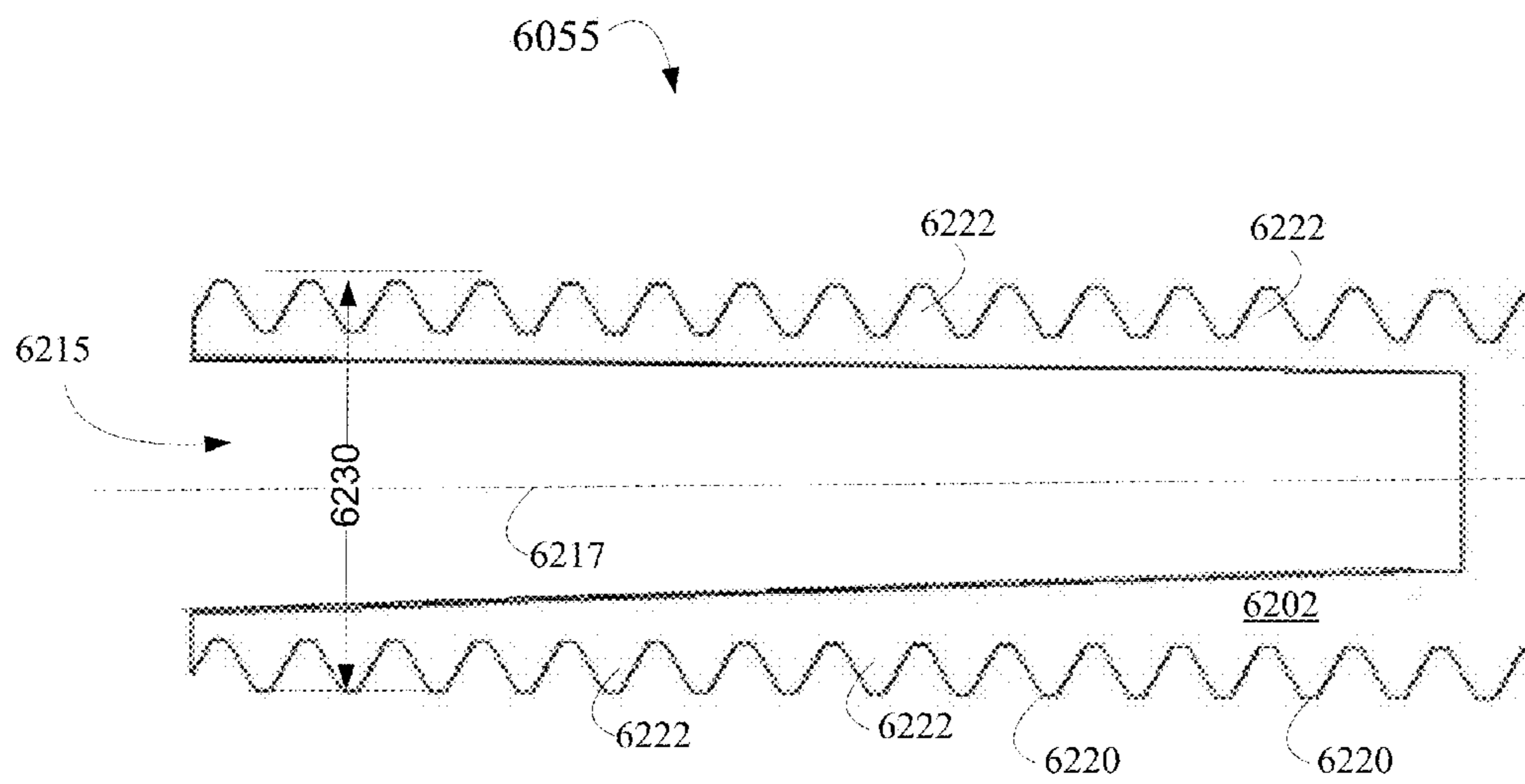

FIG. 6

1

BLENDED SHAFT DRIVE

BACKGROUND

Shaft drive tools, generally, have insufficient torque carrying capability and can fail under torsion loading. Specifically, shaft drive tools incorporate a drive feature that transitions rapidly to a base geometry (usually a cylinder), and this rapid transition in geometry creates a failure location at which stress risers accumulate and cause catastrophic failure under load. Occurrences of this type of failure are increasingly likely as drive tools are narrowed for the delivery of increasingly smaller diameter fasteners. A need therefore exists for an improved shaft drive.

SUMMARY

One approach provides an improved blended shaft delivery device. The delivery device includes a solid, monolithic shaft member. The shaft member has an engagement end. The engagement end has a proximal end and a distal end. The proximal end has a first cross-sectional geometry, and the distal end has a second cross-sectional geometry. The first cross-sectional geometry of the proximal end is different from the second cross-sectional geometry of the distal end. The cross-sectional geometry of the distal end transitions to the cross-sectional geometry of the proximal end along a longitudinal axis of the engagement end of the solid, monolithic shaft member. The transition provides a gradual, blending, continuously transitioning cross-sectional geometry along the entire length of the longitudinal axis of the engagement end of the solid, monolithic shaft member.

In some examples, the cross-sectional geometry of the distal end is in a shape of at least one of a triangle, a square, a rectangle, a hex, a circle, an ellipse, a cross, and a torx. In some examples, the cross-sectional geometry of the proximal end is in a shape of at least one of a triangle, a square, a rectangle, a hex, a circle, an ellipse, a cross, and a torx. In other examples, cross-sectional geometry of the distal end of the delivery device is in a shape of a polygon.

In some examples, the solid, monolithic shaft member has no abrupt transitions in cross-sectional geometries along the longitudinal axis, and the cross-sectional geometry of at least one of the proximal end or the distal end has a shape adapted to mate with a fastener cavity of substantially the same shape. In some examples, the fastener cavity provides a blending, continuously transitioning cross-sectional geometry along the longitudinal axis of the cavity adapted for receiving the blending, continuously transitioning cross-sectional geometry of the engagement end of the solid, monolithic shaft. In other examples, the fastener cavity includes at least two different cross-sectional geometries.

In some examples, the engagement end of the delivery device has a yield strength ranging between 175,000 psi and 250,000 psi, and in other examples, the engagement end of the delivery device has a yield strength is 220,022 psi.

Another approach is a fastening system. The fastening system includes a solid, monolithic shaft member having an engagement end. The engagement end has a proximal end and a distal end. The proximal end has a first cross-sectional geometry, and the distal end has a second cross-sectional geometry. The first cross-sectional geometry of the proximal end is different from the second cross-sectional geometry of the distal end. The cross-sectional geometry of the distal end transitions to the cross-sectional geometry of the proximal end along a longitudinal axis of the solid, monolithic shaft member. The transition provides a gradual, blending, con-

2

tinuously transitioning cross-sectional geometry along the entire length of the longitudinal axis of the engagement end of the solid, monolithic shaft member. The fastener system includes a fastener defining a longitudinal cavity of substantially the same shape as the cross-sectional geometry of at least one of the proximal end or the distal end of the engagement end of the solid, monolithic shaft.

In some examples, the cross-sectional geometry of the distal end is in a shape of at least one of a triangle, a square, a rectangle, a hex, a circle, an ellipse, a cross, and a torx. In some examples, the cross-sectional geometry of the proximal end is in a shape of at least one of a triangle, a square, a rectangle, a hex, a circle, an ellipse, a cross, and a torx. In other examples, the engagement end of the solid, monolithic shaft member includes no abrupt transitions in cross-sectional geometries along the longitudinal axis.

In some examples, the longitudinal cavity of the fastener provides a blending, continuously transitioning cross-sectional geometry along the longitudinal axis adapted for receiving the blending, continuously transitioning cross-sectional geometry of the engagement end of the solid, monolithic shaft. In some examples, the longitudinal cavity includes at least two different cross-sectional geometries along the longitudinal axis.

Another approach is a fastener for securing a suture. The fastener includes a body member having an exterior surface and defining an interior cavity. The exterior surface includes a fixation element; and the interior cavity includes a longitudinal cavity having a blending, continuously transitioning cross-sectional geometry along the longitudinal axis of the body member. In some examples, the longitudinal cavity includes at least two different cross-sectional geometries. In some examples, the longitudinal cavity is adapted for receiving an engagement end of a drive shaft having a cross-sectional geometry of substantially the same shape as the longitudinal cavity. In some examples, the exterior surface of the fastener further includes a retention element.

The blended shaft drive and fastening system described herein provides one or more of the following advantages. For example, one advantage of the blended shaft drive and fastening system is that the blended shaft drive allows for the application of increased torsional strength during fastener delivery, thereby enabling the blended shaft drive to secure a fastener without breaking and thereby reducing costs and health risks related to removing and replacing broken shaft and fastener assemblies from a patient undergoing arthroscopic surgery. Another advantage of the technology is that the blended shaft drive allows for reduced fastener size (i.e., reduced overall fastener implant size), thereby decreasing the manufacturing cost for the technology by reducing materials, improving fastener deployment in low clearance areas, and/or minimizing physical trauma to a recipient of the fastener. Another advantage of the technology is that the blended shaft drive allows for greater fixation strength of the mating fastener (e.g., less implant volume dedicated to applying torque allows for greater implant volume dedicated to fixation strength), thereby improving likelihood of fastener retention while reducing the overall cost and physical trauma to a recipient.

Other aspects and advantages of the current technology will become apparent from the following detailed description, taken in conjunction with the accompanying drawings, illustrating the principles of the technology by way of example only.

BRIEF DESCRIPTION OF THE DRAWINGS

The foregoing features of various examples of the technology will be more readily understood by reference to the following detailed descriptions in the accompanying drawings, in which:

FIG. 1A is a schematic illustration of a perspective view of a fastening system, according to an illustrative example;

FIG. 1B is an enlarged bottom perspective view of a portion of the fastening system, according to the illustrative example of FIG. 1A;

FIG. 1C is a schematic illustration of a top perspective exploded view of a portion of the fastening system, according to the illustrative example of FIG. 1A;

FIG. 1D is a schematic illustration of a bottom perspective exploded view of a portion of the fastening system, according to the illustrative example of FIG. 1A;

FIG. 1E is a schematic illustration of a top view of an assembled portion of the fastening system, according to the illustrative example of FIG. 1A;

FIG. 2 is a schematic illustration of a perspective view of a blended shaft drive, according to an illustrative example;

FIG. 3A is a schematic illustration of a cross sectional side view of a blended shaft drive mated with a fastener, according to an illustrative example;

FIG. 3B is a schematic illustration of a perspective end view of the example of FIG. 3A cross sectioned along line B-B;

FIG. 3C is a schematic illustration of a perspective end view of the example of FIG. 3A cross sectioned along line C-C;

FIG. 3D is a schematic illustration of a perspective end view of the example of FIG. 3A cross sectioned along line D-D;

FIG. 4 is a schematic illustration of a perspective view of a delivery device exhibiting stress concentrations under load, according to an illustrative example;

FIG. 5 is a schematic illustration of a perspective view of a prior art delivery device exhibiting stress concentrations under load; and

FIG. 6 is a schematic illustration of a cross sectional side view of a fastener, according to an illustrative example.

DETAILED DESCRIPTION

The blended shaft drive includes components that enable the reliable affixation of compact fasteners requiring secure placement in low clearance and/or limited access areas. For example, one use of the blended shaft drive is for securing a device (anchor/fastener/suture) that connects tendon to bone without causing a patient unnecessary physical trauma otherwise caused by invasive arthroscopic procedures. Because tendons absorb and impart strong forces, the device must affix such tendons securely to bone to enable successful healing. In this example, secure affixation is achieved by a system of an anchor and fastener, a suture, and the blended shaft drive that deploys the fastener within an anchor for securing the suture attached to a tendon. Compared to legacy drive tools, the blended shaft drive is relatively narrow for deploying a compact fastener that requires minimal clearance and a relatively small area footprint in the bone. Because the blended shaft geometry has no abrupt transitions, the relatively narrow blended shaft drive withstands high torque forces (at least 3 in-lbf) without breaking/failure.

FIGS. 1A through 1E depict an example of a fastening system 1000 including a high strength delivery device 1010 and a two part footprint anchor 1050. FIG. 1A illustrates the

assembled components of the fastening system 1000. FIG. 1B shows a exploded enlarged portion of the fastening system 1000 of FIG. 1A. FIGS. 1C and 1D show exploded perspective views of the exploded portion of FIG. 1B. FIG. 1E shows an example of an enlarged schematic top view of assembled components of the fastening system 1000.

The delivery device 1010 includes an insertion handle 1015 and a two-part insertion shaft 1020 having a hollow outer shaft 1030 surrounding an inner, solid, monolithic shaft member 1025. The solid, monolithic shaft member 1025 is adapted for applying torque to an engaged fastener 1055. In some examples, the fastener 1055 requires placement within a receiving cavity of an outer body 1060 for securing a suture 1045 therebetween. The outer shaft 1030 engages with the outer body 1060. For example, the delivery device 1000 could be one for engaging, delivering, and securing a suture fixation fastening system for use in arthroscopic procedures involving securing tissue to bone. As some examples, the delivery device 1010 could be one for engaging, delivering and securing a fastener in any low-clearance assembly, such as those forming components of aircraft, automobiles, and bicycles, all of which require high torque fasteners in densely populated areas.

With regard to the example of a suture fixation fastening system 1000, such a system requires application of high torque on the fastener 1055 to secure a suture 1045 against the outer body 1060, which is securely driven into a bore formed in a bone 1070. The two-part footprint anchor 1050 thereby enables attachment of tissue (e.g., a tendon) to bone. Turning a torque limiter knob 1035 at the top of the inserter handle 1015 transfers torque to the solid monolithic shaft member 1025. The application of torque limiter knob 1035 enables the solid, monolithic shaft member 1025 to secure a fastener 1055 within the outer body 1060 without over tensioning the fastener 1055. The delivery device 1010 therefore secures strong tendon tissue to bone without the solid monolithic shaft member 1025 breaking/failing under the application of torsion force. This advantageously reduces costs and time otherwise associated with removing and replacing an assembly of the broken solid, monolithic shaft member 1025, the fastener 1055 and the suture 1045 from patients during surgery. Withstanding high torque forces enables the delivery device 1000 to deliver the fastener 1055 reliably, therefore decreasing the risks associated with prolonged surgery. The solid, monolithic shaft member 1025 also allows for reduced fastener size (i.e., reduced overall fastener implant size), thereby decreasing the manufacturing cost for the technology by reducing materials, improving fastener deployment in low clearance areas, and/or minimizing physical trauma to a recipient of the two part footprint anchor 1050. The solid, monolithic shaft member 1025 allows for greater fixation strength of the mating fastener 1055 (e.g., less implant volume dedicated to applying torque allows for greater implant volume dedicated to fixation strength), thereby improving the likelihood of fastener 1055 retention while reducing the overall cost of manufacture of the fastening system 1000.

FIG. 2 depicts a portion of an exemplary delivery device (e.g., delivery device 1010 of FIG. 1A), which includes a solid, monolithic shaft member 2025 having an engagement end 2102 for driving a fastener (e.g. fastener 3255 of FIG. 3A). In some examples, the solid, monolithic shaft member 2025 is manufactured from a single, solid piece of stock (e.g., surgical steel, composite, etc.). The solid, monolithic shaft member 2025 can be, for example, a unitary, single-component body having no cavity therein. The engagement end 2102 of the solid, monolithic shaft member 2025 has a proximal end 2105 and a distal end 2110 for engaging with the

5

fastener **3255**. The proximal end **2105** has a first cross-sectional geometry **2107** and the distal end **2110** end has a second cross-sectional geometry **2112**. The first cross-sectional geometry **2107** of the proximal end **2105** is different from the second cross-sectional geometry **2112** of the distal end **2110**. As illustrated in FIG. 2, the first cross-section geometry **2107** of the proximal end **2105** is a circle and the second cross-section geometry **2112** of the distal end **2110** is a triangle with flattened corners **2114**. The flattened corners **2114** can prevent any concentrated, localized applications of force that would create potential modes of failure. Sharp corners on an engagement end can lead to potential cracking and/or fatiguing of a mated fastener during application of torque, thereby causing health risks and trauma associated with prolonging surgery to remove and replace a fastener and any deployed suture which has already been attached to the tissue requiring affixation to bone.

The second cross-sectional geometry **2112** of the distal end **2110** transitions to the first cross-sectional geometry **2107** of the proximal end **2105** along a longitudinal axis **2115** of the engagement end **2102** of the solid, monolithic shaft member **2025**. The transition provides a gradual, blending, continuously transitioning cross-sectional geometry along the entire length of the longitudinal axis **2115** of the engagement end **2102** of the solid, monolithic shaft member **2025**. The first cross-sectional geometry **2107** of the proximal end **2105** therefore transitions into the second cross-sectional geometry **2112** of the distal end **2110** without any abrupt transitions that would trigger the accumulation of stress risers (i.e., areas of concentrated stress) that could lead to catastrophic yield or breakage. A rapid transition in geometry (i.e., a geometric discontinuity) weakens an object because force is not evenly distributed over the object. Instead, localized increases in stress occur when an abrupt transition in geometry occurs. By smoothly and progressively transitioning from one cross-sectional geometry to another along the longitudinal axis **2115** of the engagement end **2102**, the solid, monolithic shaft **2025** eliminates rapid transitions, such as tapers and undercuts, and therefore eliminates rapid physical changes that induce stress risers. The smooth and progressive transition advantageously enables the application of high torque without the risk of breaking apart the solid, monolithic shaft **2025** and requiring costly and risky extraction and replacement of the fastener **3255** and suture (not shown).

In some examples, the cross-sectional geometry of the distal end **2110** is in a shape of at least one of a triangle, a square, a rectangle, a hex, a circle, an ellipse, a cross, and a torx, for example. In some examples, the cross-sectional geometry of the proximal end **2105** is in a shape of at least one of a triangle, a square, a rectangle, a hex, a circle, an ellipse, a cross, and a torx, for example. In other examples, the cross-sectional geometry of the distal end **2105** is in a shape of a polygon, the sides thereof providing sufficient contact with a fastener (e.g. **3255** of FIG. 3A) such that an application of torque on the solid, monolithic shaft **2025** drives the engaged fastener **3255**. In yet some examples, a torque application end **2120** includes at least a third cross sectional geometry (not shown). In examples, any number of cross-sectional geometries is contemplated such that the transitions between geometries are progressive and no abrupt transitions in geometry exist. Although the distal end **2110** and the proximal end **2105** are described as being one of a listed shape, the distal end **2110** and/or the proximal end **2105** can be any shape and/or any combination of shapes (e.g., square to diamond, torx to circle, rectangle to octagon, etc.)

In some examples, the cross-sectional geometry of at least one of the proximal end **2105** or the distal end **2110** has a

6

shape adapted to mate with a fastener cavity (e.g. **3215** of FIG. 3A) of substantially the same shape. In some examples, the fastener cavity provides a blending, continuously transitioning cross-sectional geometry along the longitudinal axis (e.g. **3217** of FIGS. 3B, 3C and 3D) of the cavity adapted for receiving the blending, continuously transitioning cross-sectional geometry of the engagement end **2102** of the solid, monolithic shaft **2025**. In other examples, the fastener cavity includes at least two different cross-sectional geometries (e.g., square and diamond, torx and circle, rectangle and octagon, etc.).

The engagement end **2102** of the solid, monolithic shaft **2025** of FIG. 2 inserts into a fastener cavity (e.g. **3215** of FIG. 3A). As shown in the exemplary fastener **3255** and engagement end **2102** assemblies of FIGS. 3A through 3D, the fastener **3255** is sized and shaped to accommodate the blending, continuously transitioning cross-sectional geometry of the engagement end **2102** so that fastener **3255** and engagement end **2102** are mated in a press fit or substantially press fit configuration. The engagement end **2102** outside dimension **2125** is substantially equal to or less than the diameter of the fastener cavity **3215**. In some examples, the cavity **3215** is sized to accommodate the blending, continuously transitioning cross-sectional geometry of the engagement end **2102** in a press fit, or substantially press fit, configuration such that the engagement end **2102** can deliver fastener **3255** while still enabling removal of the solid, monolithic shaft **2025** from the cavity **3215** following secured placement of the fastener **3255**. This enables the successful application of high torque (e.g., 3 in-lbf, 4 in-lbf, etc.) required to properly secure components, e.g. a sutured tendon to bone, while preventing the development of stress risers along the blending, continuously transitioning cross-sectional geometry of the engagement end **2102**. By preventing stress risers, the solid, monolithic shaft **2025** reliably deploys a fastener **3255** without breaking off in the fastener. Preventing such breakage eliminates the health risks and costs associated with removal and replacement of the faster and suture.

FIGS. 3B, 3C, and 3D are cross sectional views of the exemplary fastener-shaft assembly **3000** of FIG. 3A cross sectioned along lines B-B, C-C, and D-D respectively. As illustrated in FIG. 3B, the fastener cavity **3215** has a substantially circular cross sectional shape **3215a** at a proximal end **3205** of the fastener **3255** (i.e., point (B-B) along the longitudinal axis **3217**). As illustrated in FIG. 3C, the fastener cavity **3215** has a hybrid circle-triangle cross sectional shape **3215b** at a midway point (C-C) along the longitudinal axis **3217**, and as illustrated in FIG. 3D, the fastener cavity **3215** has a triangular cross sectional shape **3215c** at a distal end **3210** of the fastener **3255** (i.e., a point (D-D) along the longitudinal axis **3217**).

As depicted in FIG. 4, in some examples, the engagement end **4102** of a solid, monolithic shaft **4025** has a yield strength ranging between 175,000 psi and 250,000 psi, and in other examples, the engagement end **4102** has a yield strength of 220,022 psi. This range of yield strengths is three times greater than a legacy drive tool **5025** depicted in FIG. 5 that incorporates an engagement end **5102** of continuous cross sectional geometry that transitions rapidly at a taper or undercut **5105**, for example, into a larger geometry. Such a legacy drive tool **5025** typically fails under a torque load of 3 in-lbf, the torque required to secure a suture within an arthroscopic fastening anchor system comprising a fastener (not shown) mated to an anchor (not shown) with a suture secured therebetween. As FIG. 5 indicates, a stress riser occurs at the transition point **5110** between the engagement end **5102** and

the larger diameter portion **5112** of the drive tool **5025**, and adjacent the rapid transition in geometry occurring at the taper **5105**.

By eliminating rapid transitions in geometry, the solid, monolithic shaft **4025** addresses the issue of catastrophic failure that would lead to the engagement end **4102** snapping off of the solid, monolithic shaft **4025** during deployment of a fastener (not shown). As the example of FIG. 4 indicates, the solid monolithic shaft **4025** withstands 3 in-lbf of torque without exhibiting concentrated stress risers that would lead to catastrophic failure. The solid, monolithic shaft **4025** therefore enables the delivery and fastening of extremely small fasteners without the solid, monolithic shaft **4025** breaking under torque load required, for example, for proper suture fixation during arthroscopic surgery.

In some examples, such as the example of related FIGS. 2 and 3B, the outside dimension **2125** of the distal end **2110** of engagement end **2102** is no more than 1.2 mm and the outside diameter **3230** of the fastener **3255** is no more than 2 mm. In this example, the engagement end **2102** and fastener are no more than 10 mm long each as measured along longitudinal axes **2115** and **3217**. In this example, the delivery device comprising the engagement end **2102** and torque application end **120** is 16 inches long. Eliminating abrupt transitions in geometry therefore enables a solid, monolithic shaft **2025** to deliver a micro-scale fastener **3255** in a low clearance area and apply sufficient torque (e.g., 3 in-lbf) to secure sutures **1045** without catastrophic breakage of the delivery device (e.g., **1010** of FIG. 1A). The progressive transition in cross-sectional geometry allows for increased torsional strength of the delivery device and decreased fastener diameter.

Another example is a fastening system **1000** including a solid, monolithic shaft member **1025** and a fastener **1055**. In some examples, the solid, monolithic shaft member **1025** has an engagement end **2102**, and the engagement end **2102** has a proximal end **2105** and a distal end **2110**. The proximal end **2105** has a first cross-sectional geometry **2107** and the distal end **2110** has a second cross-sectional geometry **2112**, and the first cross-sectional geometry **2107** of the proximal end **2105** is different from the second cross-sectional geometry **2112** of the distal end **2110**. The second cross-sectional geometry **2112** of the distal end **2110** transitions to the cross-sectional geometry **2107** of the proximal end **2105** along a longitudinal axis of the solid, monolithic shaft member **2025** providing a gradual, blending, continuously transitioning cross-sectional geometry along the entire length of the longitudinal axis **2115** of the engagement end **2102** of the solid, monolithic shaft member **2025**. In examples, the fastener system includes a fastener **3255** defining a longitudinal cavity **3215** of substantially the same shape as the cross-sectional geometry of at least one of the proximal end **2105** or the distal end **2110** of the engagement end **2102** of the solid, monolithic shaft member **1025**.

In some examples, the second cross-sectional geometry **2112** of the distal end **2110** is in a shape of at least one of a triangle, a square, a rectangle, a hex, a circle, an ellipse, a cross, and a torx. In some examples, the cross-sectional geometry of the proximal end **2105** is in a shape of at least one of a triangle, a square, a rectangle, a hex, a circle, an ellipse, a cross, and a torx. In other examples, the engagement end **2102** of the solid, monolithic shaft member **2025** includes no abrupt transitions in cross-sectional geometries along the longitudinal axis **2115**.

As depicted in the illustrative examples of FIGS. 3A through 3D, the longitudinal cavity **3215** of the fastener **3255** provides a blending, continuously transitioning cross-sectional geometry along the longitudinal axis **3217** adapted for

receiving the blending, continuously transitioning cross-sectional geometry of the engagement end **2102** of the solid, monolithic shaft **2025**. In examples, the longitudinal cavity **3215** includes at least two different cross-sectional geometries along the longitudinal axis **3217**. In some examples, the cavity **3215** is sized to accommodate the blending, continuously transitioning cross-sectional geometry of the engagement end **2102** of FIG. 2 in a press fit or substantially press fit configuration such that the engagement end **2102** can deliver fastener **3255** while still enabling removal of the solid, monolithic shaft **2025** from the cavity **3215** following securing the fastener **3255**.

Illustrated in FIG. 6 is an exemplary fastener **6055** for securing a suture including a body member **6202** having an exterior surface **6220** and defining an interior cavity **6215**. The exterior surface **6220** includes a fixation element **6222**. In one example, the fixation element **6222** includes threads or barbs and threads; however it is possible that the fixation element **6222** may include only barbs. The interior cavity **6215** of the exemplary fastener **6055** includes a longitudinal cavity having a blending, continuously transitioning cross-sectional geometry along the longitudinal axis **6217** of the body member **6202**. In some examples, the longitudinal cavity **6215** includes at least two different cross-sectional geometries, as depicted in the illustrative examples of FIGS. 3A through 3D. In the illustrated example, the cross sectional geometry of the longitudinal cavity **3215** progressively transitions from a circle-shaped cavity **3215a** to a triangle shaped cavity **3215c**. In some examples, such as that of FIGS. 2 through 3D, the longitudinal cavity **3215** is adapted for receiving an engagement end **2102** of a solid, monolithic shaft **2025** having a cross-sectional geometry of substantially the same shape as the longitudinal cavity **3215**.

In some examples, such as that of FIG. 6, the exterior surface **6220** of the fastener **6055** further includes at least one retention element (not shown). The retention element may be threads or barbs or a combination of threads and barbs, for example. For the purposes of this technology, the retention element includes threads or barbs and threads; however it is possible that the retention element may include only barbs. For example, two thirds of the exterior surface (e.g., as measured along the longitudinal axis) can be covered in a fixation element **6222** of engagement threads and the remaining third can comprise a retention element of one or more retention barbs. In any example, the lack of abrupt geometric transition along the solid, monolithic shaft (e.g. **2025** of FIG. 2) of the delivery device (e.g. **1010** of FIG. 1A) enables reduction in size of the deployed fastener **6055**. Specifically, the gradual transition along the solid, monolithic shaft allows for a reduction in outside diameter **6230** of the fastener **6055**. This thereby allows for greater fixation strength because less volume of the fastener **6055** is dedicated to applying torque and a greater volume is dedicated to fixation strength (e.g., deeper threads).

Comprise, include, and/or plural forms of each are open ended and include the listed parts and can include additional parts that are not listed. And/or is open ended and includes one or more of the listed parts and combinations of the listed parts.

One skilled in the art will realize the technology may be embodied in other specific forms without departing from the spirit or essential characteristics thereof. The foregoing examples are therefore to be considered in all respects illustrative rather than limiting of the technology described herein. Scope of the technology is thus indicated by the appended claims, rather than by the foregoing description,

and all changes that come within the meaning and range of equivalency of the claims are therefore intended to be embraced therein.

I claim:

1. A delivery device, comprising:
a solid, monolithic shaft member having an engagement portion at an end of the monolithic shaft member, the engagement portion having a longitudinal axis extending from a proximal terminus to a distal terminus, wherein:
 - a) the proximal terminus has a first cross-sectional geometry and the distal terminus has a second cross-sectional geometry, the first cross-sectional geometry of the proximal terminus being different from the second cross-sectional geometry of the distal terminus; and
 - b) a periphery of the engagement member continuously changing from a second cross-sectional geometry of the distal terminus to the first cross-sectional geometry of the proximal terminus along the longitudinal axis of the engagement portion, in which substantially every portion of the peripheral cross-sectional geometry of the engagement member is continuously changing along an entire length of the longitudinal axis of the engagement member.
2. The delivery device of claim 1, wherein the cross-sectional geometry of the distal terminus is in a shape of at least one of a triangle, a square, a rectangle, a hex, a circle, an ellipse, a cross, and a torx.
3. The delivery device of claim 1, wherein the cross-sectional geometry of the proximal terminus is in a shape of at least one of a triangle, a square, a rectangle, a hex, a circle, an ellipse, a cross, and a torx.
4. The delivery device of claim 1, wherein the cross-sectional geometry of the distal terminus is in a shape of a polygon.
5. The delivery device of claim 1, wherein the solid, monolithic shaft member comprises continuous transitions in cross-sectional geometries along the longitudinal axis.
6. The delivery device of claim 1, wherein the cross-sectional geometry of at least one of the proximal terminus and the distal terminus has a shape adapted to mate with a fastener cavity based on the same shape.
7. The delivery device of claim 6, wherein the fastener cavity provides a blending, continuously transitioning cross-sectional geometry along a longitudinal axis of the cavity adapted for receiving the blending, continuously transitioning cross-sectional geometry of the engagement portion of the solid, monolithic shaft.
8. The delivery device of claim 6, wherein the fastener cavity provides a blending, continuously transitioning cross-sectional geometry blending from a first of at least two different cross-sectional geometries to a second of at least two different cross-sectional geometries.
9. The delivery device of claim 1, wherein the engagement portion has a yield strength ranging between 175,000 psi and 250,000 psi.
10. The delivery device of claim 9, wherein the engagement portion yield strength is 220,022 psi.
11. The delivery device of claim 1, wherein the solid, monolithic shaft member is adapted to mate with a fastener based on the same shape having matching gradual, blended, continuously transitioning cross-sectional geometry along the entire length of the longitudinal axis of the fastener such that the solid, monolithic shaft member withstands torque without exhibiting concentrated stress drivers.

12. A fastening system, comprising:
a solid, monolithic shaft member having an engagement portion at an end of the monolithic shaft member, the engagement portion having longitudinal axis extending from a proximal terminus to a distal terminus, wherein:
the proximal terminus has a first cross-sectional geometry and the distal terminus has a second cross-sectional geometry, the first cross-sectional geometry of the proximal terminus being different from the second cross-sectional geometry of the distal terminus, and
a periphery of the engagement portion continuously changes from the first cross-sectional geometry of the distal terminus to the second cross-sectional geometry of the proximal terminus along a longitudinal axis of the engagement portion along the entire length of the longitudinal axis of the engagement portion, the entire length being from the distal terminus to the proximal terminus; and
a fastener defining a longitudinal cavity of substantially the same shape as the cross-sectional geometry of at least one of the proximal terminus and the distal terminus of the engagement portion of the solid, monolithic shaft; wherein the engagement portion maintains a nominal clearance with respect to the longitudinal cavity when fully engaged therein.
13. The fastening system of claim 12, wherein the cross-sectional geometry of the distal terminus is in a shape of at least one of a triangle, a square, a rectangle, a hex, a circle, an ellipse, a cross, and a torx.
14. The fastening system of claim 12, wherein the cross-sectional geometry of the proximal terminus is in a shape of at least one of a triangle, a square, a rectangle, a hex, a circle, an ellipse, a cross, and a torx.
15. The fastening system of claim 12, wherein the engagement portion of the solid, monolithic shaft member comprises continuous transitions in cross-sectional geometries along the longitudinal axis.
16. The fastening system of claim 12, wherein the longitudinal cavity provides a blending, continuously transitioning cross-sectional geometry along the longitudinal axis adapted for receiving the blending, continuously transitioning cross-sectional geometry of the engagement portion of the solid, monolithic shaft.
17. The fastening system of claim 16, wherein the longitudinal cavity provides the blending, continuously transitioning cross-sectional geometry blending from a first of at least two different cross-sectional geometries to a second of the at least two different cross-sectional geometries along the longitudinal axis.
18. A fastener for securing a suture, comprising:
a body member comprising an exterior surface and defining an interior cavity, the body member having longitudinal axis extending from a proximal terminus to a distal terminus, wherein:
the exterior surface includes a fixation element; and
interior cavity includes a longitudinal cavity having an exterior surface continuously changing from a first cross-sectional geometry of the distal terminus to a second cross-sectional geometry of the proximal terminus, in which substantially every portion of the peripheral cross-sectional geometry of the interior cavity is continuously changing along the exterior surface of an entire length of the longitudinal axis of the body member, the entire length being from the distal terminus to the proximal terminus.
19. The fastener of claim 18, wherein the longitudinal cavity comprises at least two different cross-sectional geometries.

20. The fastener of claim 18, wherein the longitudinal cavity is adapted for receiving an engagement portion of a drive shaft having a cross-sectional geometry of substantially the same shape as the longitudinal cavity such that the drive shaft member withstands torque without exhibiting concentrated stress drivers, the engagement portion of the drive shaft having a proximal terminus and a distal terminus, wherein:

the proximal terminus has a first cross-sectional geometry and the distal terminus has a second cross-sectional geometry, the first cross-sectional geometry of the proximal terminus being different from the second cross-sectional geometry of the distal terminus, and

a periphery of the engagement member continuously changes from a second cross-sectional geometry of the distal terminus to the first cross-sectional geometry of the proximal terminus along the longitudinal axis of the engagement portion, in which substantially every portion of the peripheral cross-sectional geometry of the engagement portion continuously changing along an entire length of the longitudinal axis of the engagement portion.

21. The fastener of claim 18, wherein the exterior surface further comprises a retention element.

* * * * *