



US009076241B2

(12) **United States Patent**
Fan et al.

(10) **Patent No.:** **US 9,076,241 B2**
(45) **Date of Patent:** **Jul. 7, 2015**

(54) **METHODS AND SYSTEMS FOR DETECTING PATCH PANEL PORTS FROM AN IMAGE HAVING PERSPECTIVE DISTORTION**

(71) Applicant: **Xerox Corporation**, Norwalk, CT (US)

(72) Inventors: **Zhigang Fan**, Webster, NY (US);
Subarna Ghosh, Williamsville, NY (US); **Hengzhou Ding**, San Diego, CA (US)

(73) Assignee: **Xerox Corporation**, Norwalk, CT (US)

(*) Notice: Subject to any disclaimer, the term of this patent is extended or adjusted under 35 U.S.C. 154(b) by 167 days.

(21) Appl. No.: **13/967,978**

(22) Filed: **Aug. 15, 2013**

(65) **Prior Publication Data**
US 2015/0049918 A1 Feb. 19, 2015

(51) **Int. Cl.**
G06K 9/00 (2006.01)
G06T 7/60 (2006.01)
H04Q 1/02 (2006.01)

(52) **U.S. Cl.**
CPC **G06T 7/602** (2013.01); **H04Q 1/136** (2013.01)

(58) **Field of Classification Search**
CPC H04Q 1/136; G06T 7/0085; G06T 7/0042
See application file for complete search history.

(56) **References Cited**
U.S. PATENT DOCUMENTS

5,335,035 A 8/1994 Maeda
5,487,666 A * 1/1996 DiGiovanni 434/72
6,542,625 B1 4/2003 Lee et al.
7,479,982 B2 1/2009 Otani et al.

7,554,575 B2 6/2009 Zandifar et al.
7,750,966 B2 7/2010 Horie
7,978,845 B2 * 7/2011 Caveney et al. 379/413
8,306,935 B2 * 11/2012 Doorhy et al. 706/45
8,331,752 B2 * 12/2012 Biribuze et al. 385/135
8,345,938 B2 1/2013 Yoshida
8,499,109 B2 7/2013 Nakama
2003/0007077 A1 1/2003 Maggi
2003/0034387 A1 2/2003 Knowles et al.
2004/0085470 A1 5/2004 Miyashita
2005/0002715 A1 1/2005 Fries et al.
2008/0040277 A1 2/2008 DeWitt
2008/0082426 A1 4/2008 Gokturk et al.
2008/0130998 A1 6/2008 Maidment et al.
2008/0177640 A1 7/2008 Gokturk et al.
2009/0265251 A1 10/2009 Dunlap et al.
2009/0319388 A1 12/2009 Yuan et al.
2010/0156919 A1 6/2010 Bala et al.
2010/0250588 A1 9/2010 Kita
2010/0329547 A1 12/2010 Cavet

(Continued)

OTHER PUBLICATIONS

Nine Sigma Request for Proposal #67653, "Optical Object Recognition and Feature Mapping by Mobile Devices", 2011, 2 pp.

Primary Examiner — Shefali Goradia

(74) *Attorney, Agent, or Firm* — Fox Rothschild LLP

(57) **ABSTRACT**

A method of estimating one or more dimensions of a patch panel may include receiving an image of a patch panel that comprises a plurality of ports and one or more gaps, extracting, by a computing device, a region of interest from the received image, detecting, by the computing device, one or more possible port edges from the region of interest, fitting the detected possible port edges to a cross-ratio constancy model to determine a port-to-gap-length ratio associated with the patch panel, using the port-length-to-gap-length ratio to determine a location of one or more final port edges, and determining a location of one or more final ports based on the location of the final port edges.

18 Claims, 7 Drawing Sheets

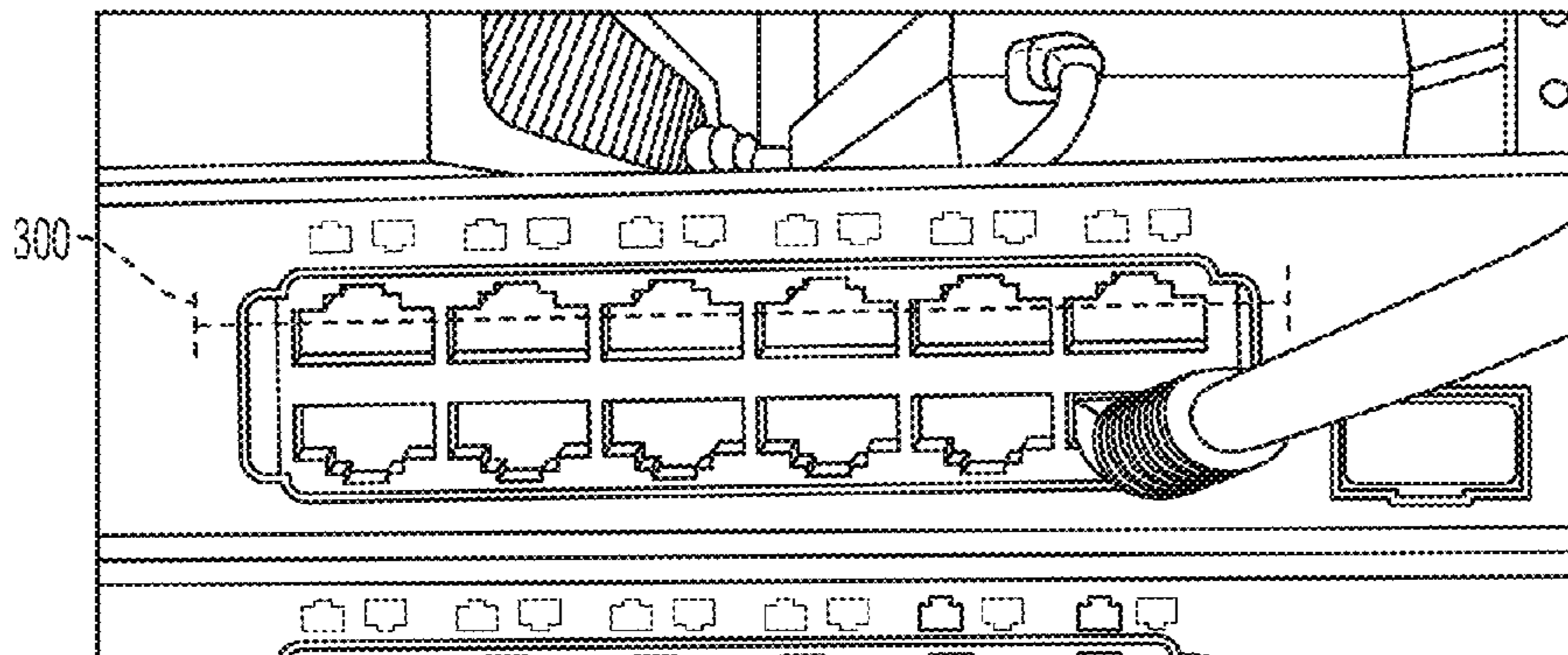

(56)

References Cited

U.S. PATENT DOCUMENTS

2011/0025873 A1 2/2011 Wang et al.
2011/0096142 A1 4/2011 Kiyoshige
2011/0234834 A1 9/2011 Sugimoto
2011/0298204 A1 12/2011 Eschbach
2012/0039514 A1 2/2012 Sun et al.

2012/0189190 A1 7/2012 Bala et al.
2013/0035081 A1 2/2013 Sanger
2013/0094715 A1 4/2013 Benkley et al.
2013/0127822 A1 5/2013 Chen et al.
2013/0183022 A1 7/2013 Suzuki et al.
2013/0198186 A1 8/2013 Parakhin et al.
2013/0293734 A1 11/2013 Fan et al.

* cited by examiner

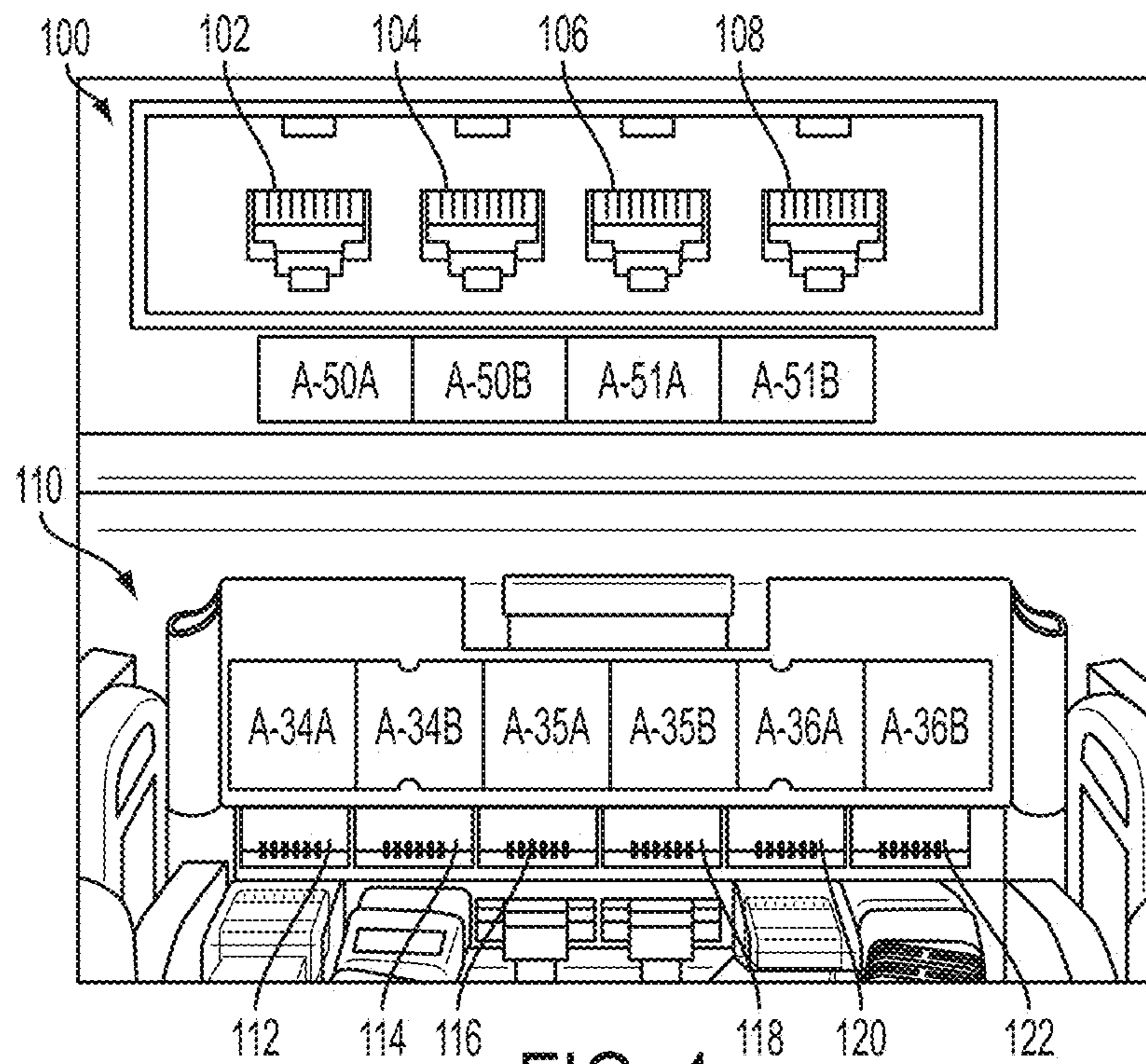

FIG. 1

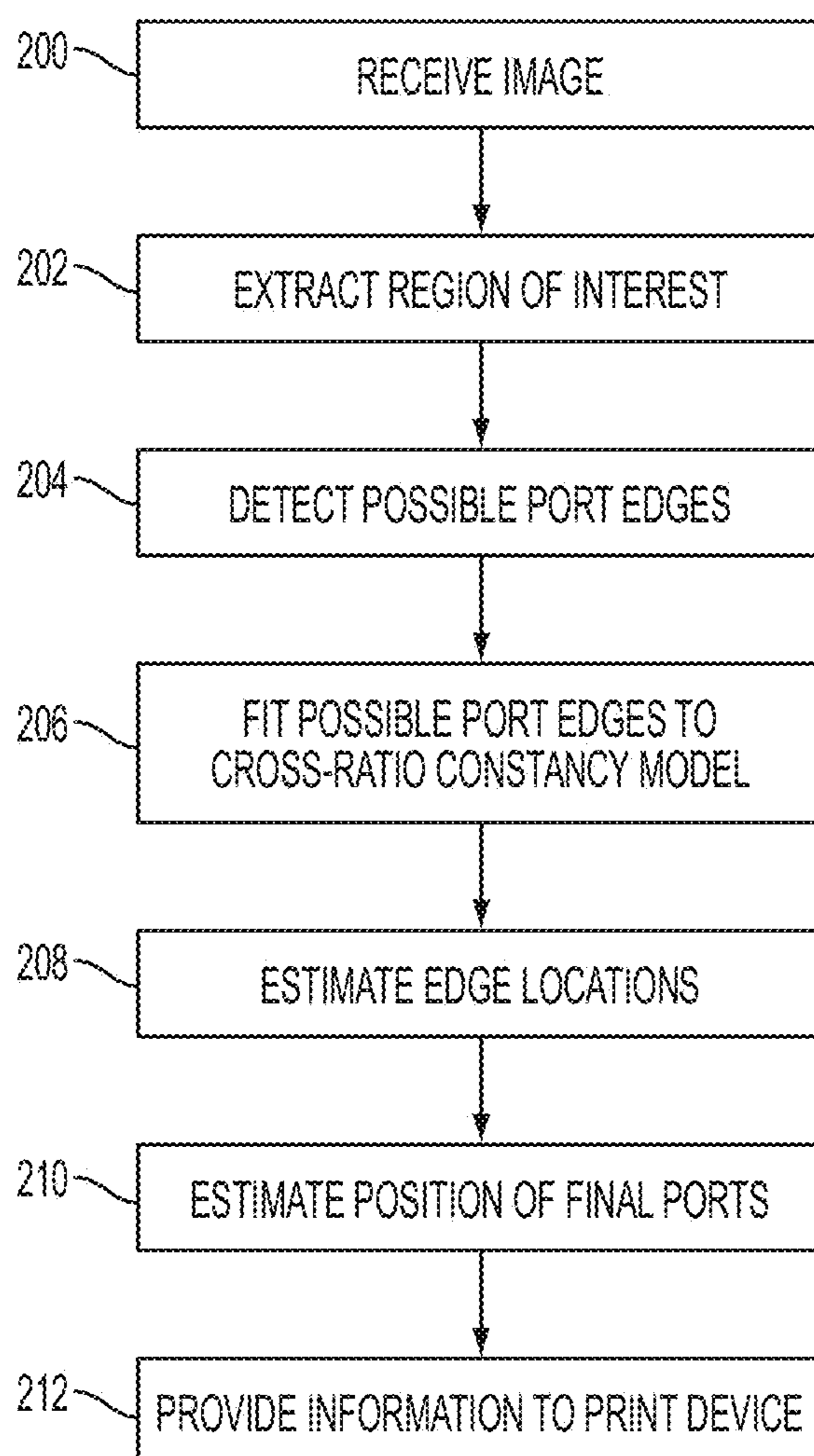

FIG. 2

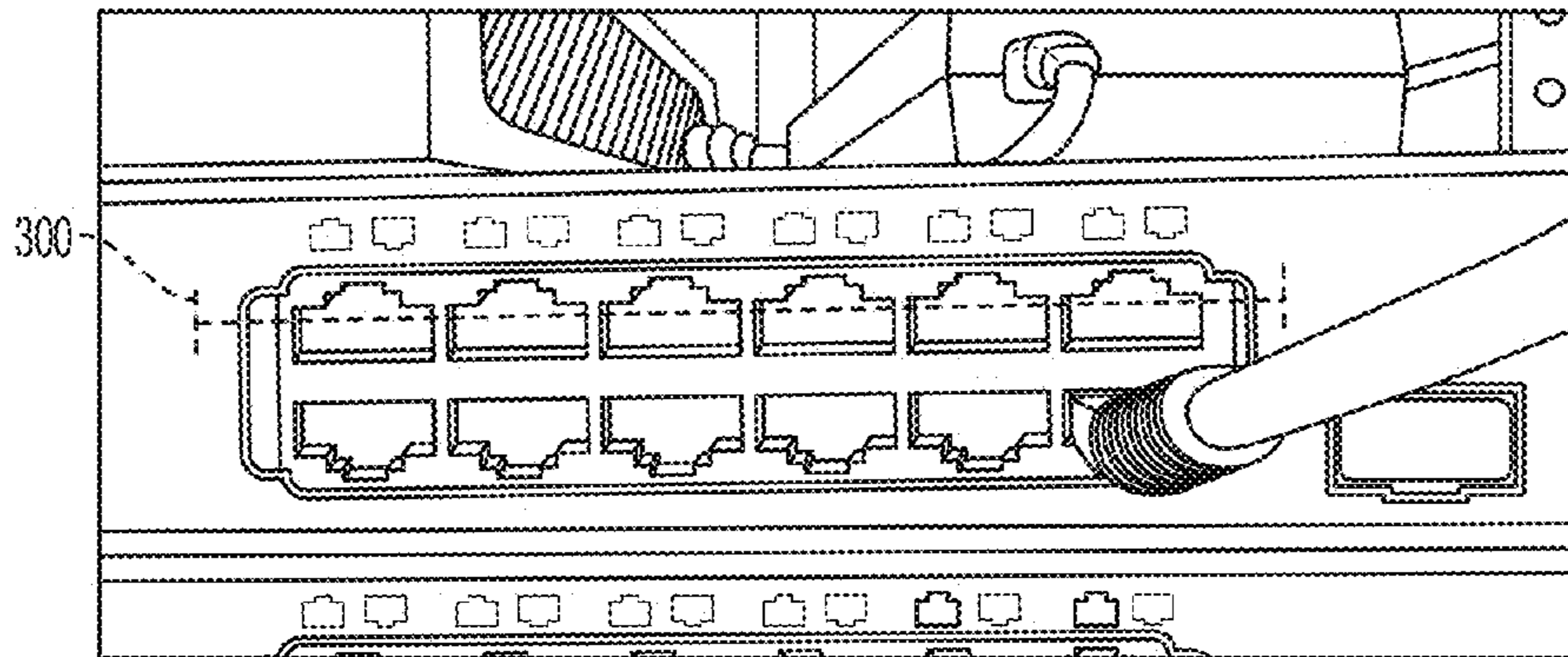

FIG. 3

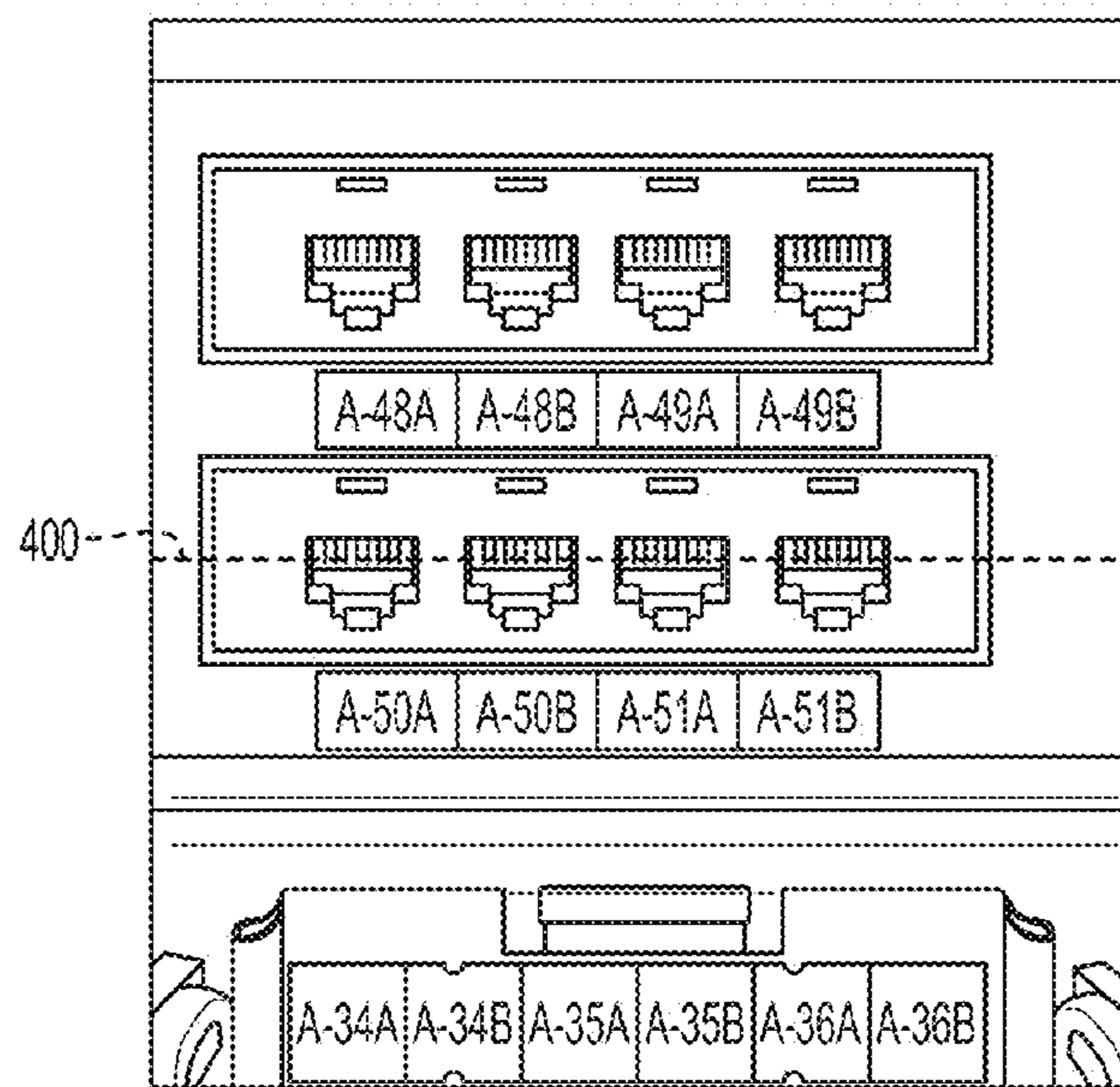

FIG. 4

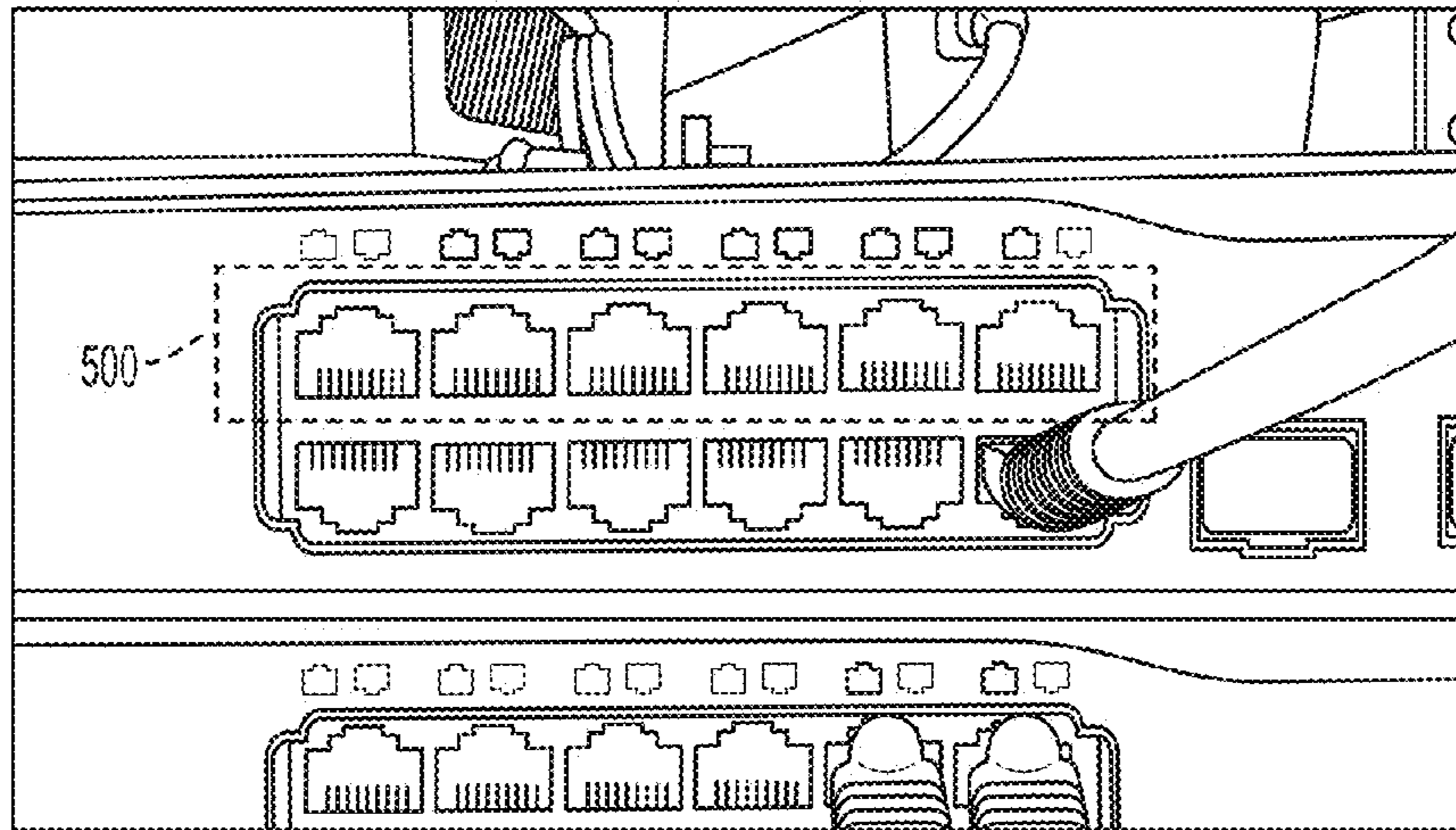

FIG. 5

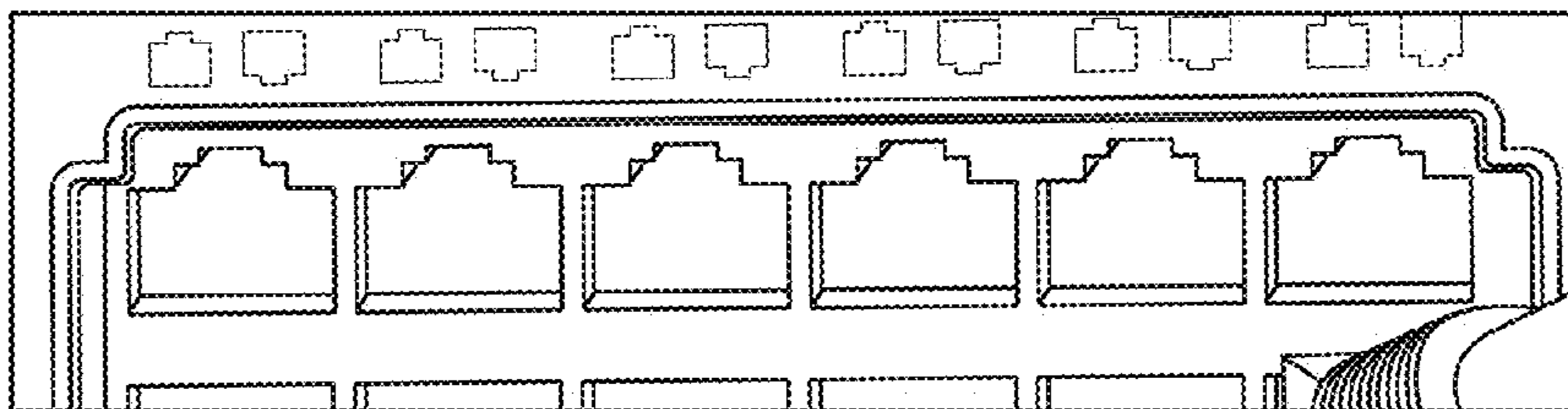

FIG. 6

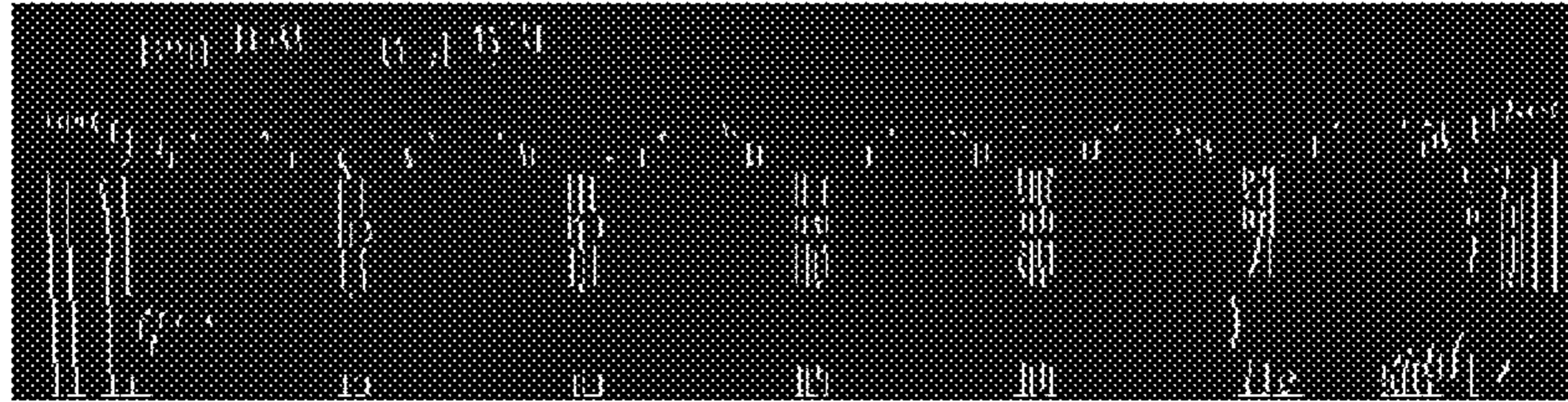

FIG. 7

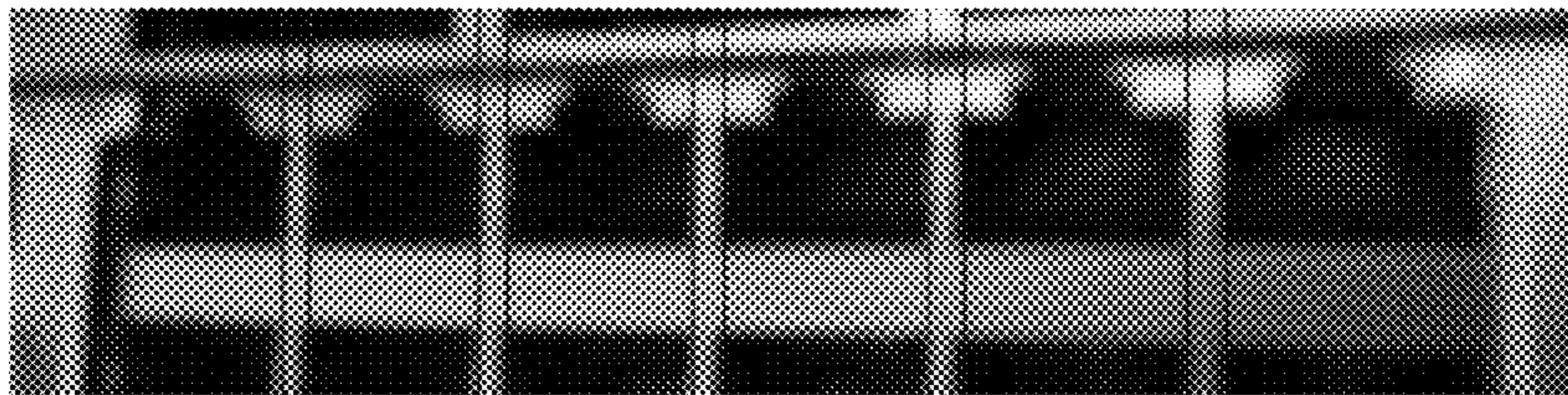

FIG. 8

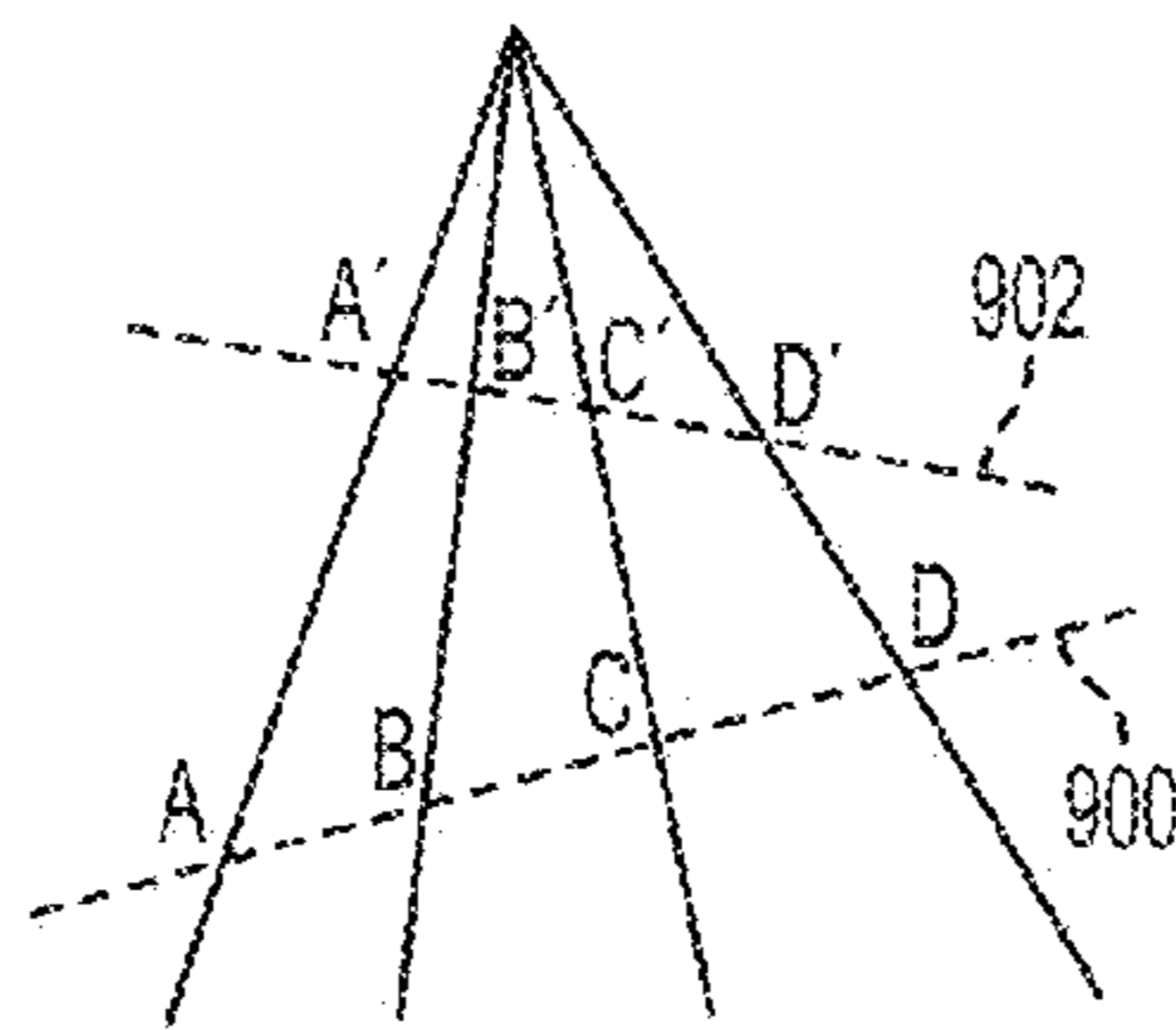

FIG. 9

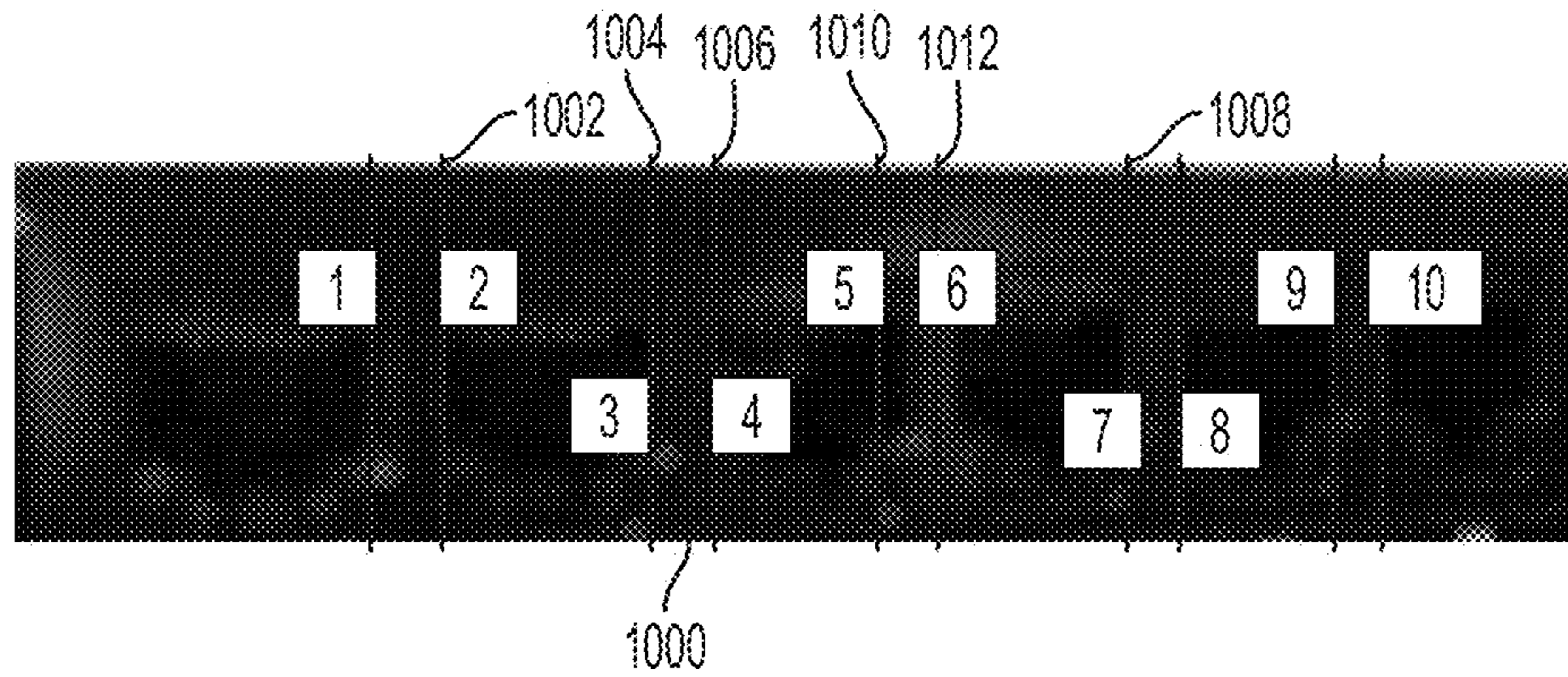

FIG. 10

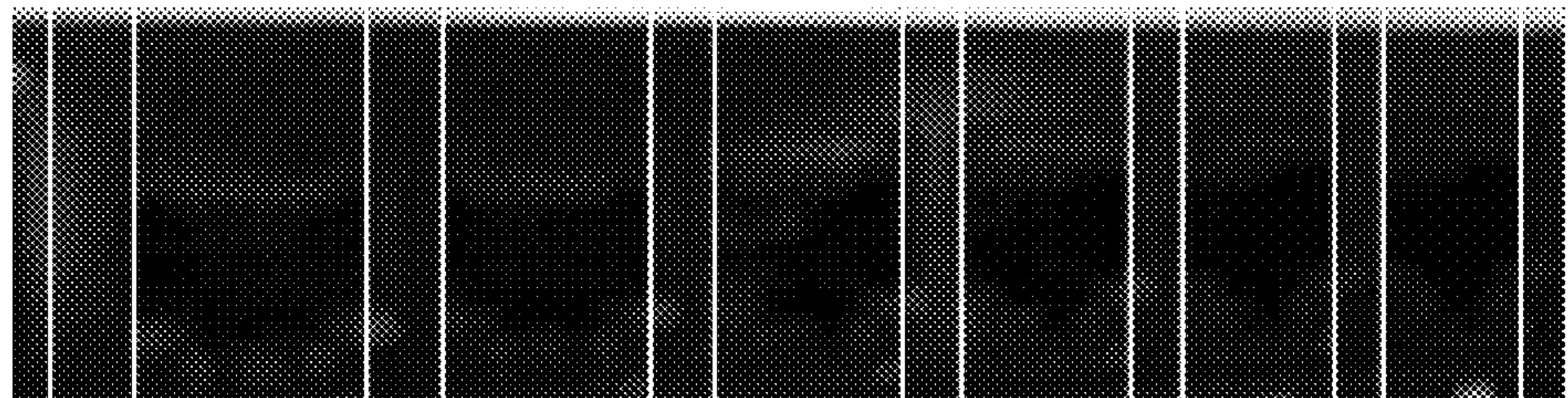

FIG. 11

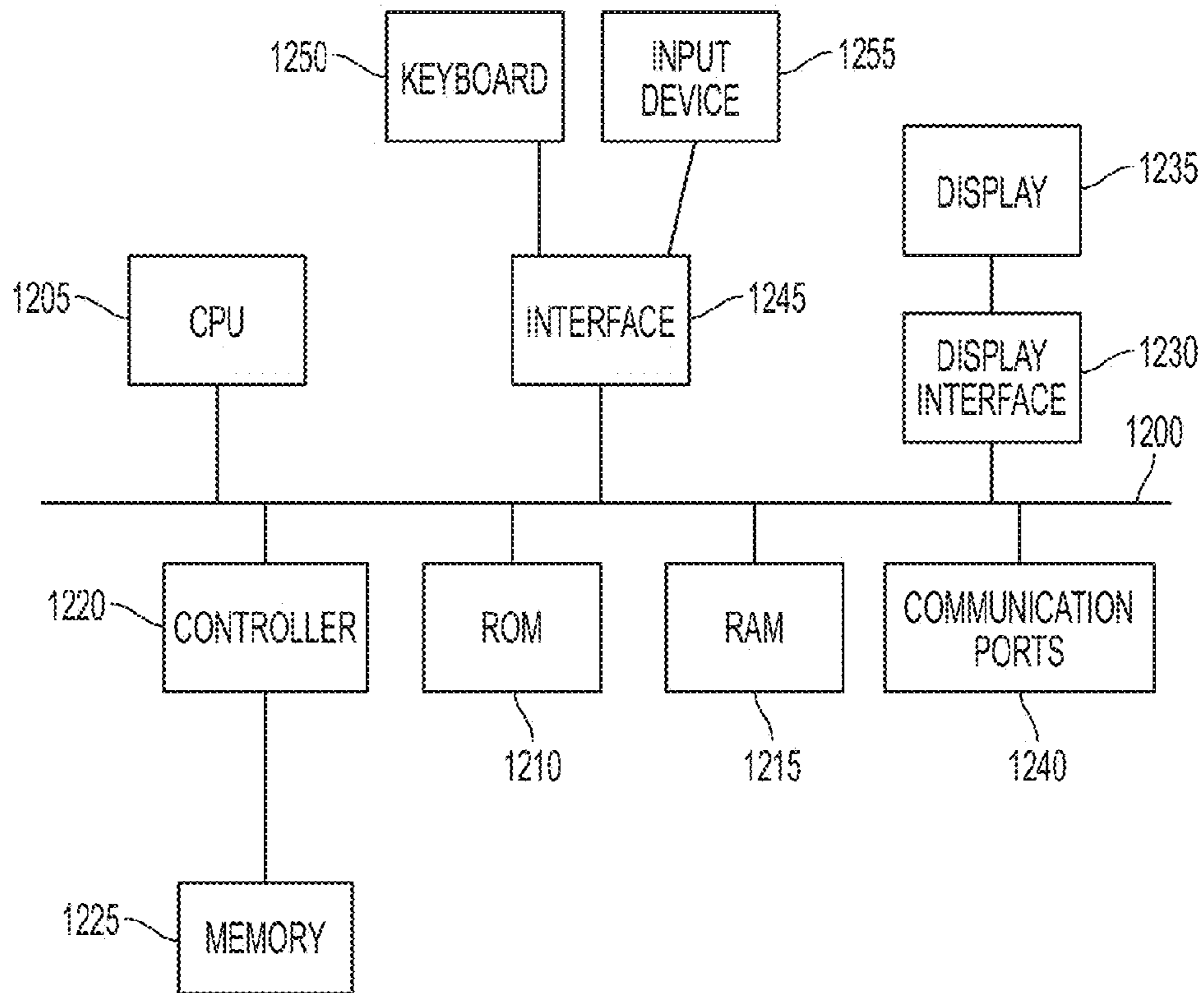

FIG. 12

**METHODS AND SYSTEMS FOR DETECTING
PATCH PANEL PORTS FROM AN IMAGE
HAVING PERSPECTIVE DISTORTION**

CROSS-REFERENCE TO RELATED
APPLICATIONS

This application is related to U.S. patent application Ser. No. 13/968,016, filed on Aug. 15, 2013.

BACKGROUND

Patch panels are commonly used in data centers to connect servers and remote clients. Due to the complexity of these data connections, there can be many wire connectors originating from a single patch panel. A data center can include tens or even hundreds of patch panels.

Labeling ports of a panel requires obtaining the number of ports, accurate sizes of the ports and inter-port distances. A traditional way to generate labels for a patch panel is to use a measuring tape to take measurements, and input the measurements into a label printer. However, this process can be tedious and inefficient. A camera-equipped electronic device, such as a smartphone, may be used to take an image of the to-be-labeled ports and estimate the dimensions of the ports. However, it may be difficult to estimate port dimensions from an image that is not captured from a fully-frontal or from a distorted perspective.

SUMMARY

This disclosure is not limited to the particular systems, methodologies or protocols described, as these may vary. The terminology used in this description is for the purpose of describing the particular versions or embodiments only, and is not intended to limit the scope.

As used in this document, the singular forms “a,” “an,” and “the” include plural reference unless the context clearly dictates otherwise. Unless defined otherwise, all technical and scientific terms used herein have the same meanings as commonly understood by one of ordinary skill in the art. All publications mentioned in this document are incorporated by reference. All sizes recited in this document are by way of example only, and the invention is not limited to structures having the specific sizes or dimension recited below. As used herein, the term “comprising” means “including, but not limited to.”

In an embodiment, a method of estimating one or more dimensions of a patch panel may include receiving an image of a patch panel that comprises a plurality of ports and one or more gaps, extracting, by a computing device, a region of interest from the received image, detecting, by the computing device, one or more possible port edges from the region of interest, fitting the detected possible port edges to a cross-ratio constancy model to determine a port-to-gap-length ratio associated with the patch panel, using the port-length-to-gap-length ratio to determine a location of one or more final port edges, and determining a location of one or more final ports based on the location of the final port edges.

In an embodiment, a system for estimating one or more dimensions of a patch panel may include a computing device and a computer-readable storage medium in communication with the computing device. The computer-readable storage medium may include one or more programming instructions that, when executed, cause the computing device to receive an image of a patch panel that comprises a plurality of ports and one or more gaps, extract a region of interest from the

received image, detect one or more possible port edges from the region of interest, fit the detected possible port edges to a cross-ratio constancy model to determine a port-to-gap-length ratio associated with the patch panel, use the port-length-to-gap-length ratio to determine a location of one or more final port edges, and determine a location of one or more final ports based on the location of the final port edges.

BRIEF DESCRIPTION OF THE DRAWINGS

FIG. 1 shows an example patch panel according to an embodiment.

FIG. 2 illustrates a flow chart of an example method of estimating patch panel measurements according to an embodiment.

FIGS. 3-5 illustrate example markers according to various embodiments.

FIG. 6 illustrates an example region of interest according to an embodiment.

FIG. 7 illustrates an example edge map according to an embodiment.

FIG. 8 illustrates an example patch panel according to an embodiment.

FIG. 9 illustrates an example original line in three-dimensional space and an example projected line according to an embodiment.

FIG. 10 illustrates an example patch panel according to an embodiment.

FIG. 11 illustrates example final port edges according to an embodiment.

FIG. 12 illustrates a block diagram of example hardware that may be used to contain or implement program instructions according to an embodiment.

DETAILED DESCRIPTION

The following terms shall have, for purposes of this application, the respective meanings set forth below:

A “gap” refers to an area between the end of one port and the beginning of an adjacent port.

A “patch panel” refers to a box in or associated with an electronic device that includes one or more ports. A patch panel may be used to connect two or more electronic or other devices via one or more wires or other connectors. For example, in a data center, a patch panel may be used to facilitate the connection a client and a server. As another example, in a recording studio, a patch panel may facilitate the connection of electronic instruments, microphones, recording devices, amplifiers and/or the like.

A “perspective distortion” refers to transformation of an object or its surrounding area in an image that differs from how the object actually appears. Examples of perspective distortions include, without limitation, an image that is captured from a perspective other than a full-frontal perspective.

A “port” refers to an electric socket of a patch panel that is configured to receive a wire or other connection.

A “port edge” refers to a vertical edge of a port.

FIG. 1 illustrates an example patch panel of an electronic device according to an embodiment. Examples of electronic devices include, without limitation, personal computers, servers, mainframes, gaming systems, televisions, and portable electronic devices such as smartphones, personal digital assistants, cameras, tablet computers, laptop computers, media players, and/or the like. Other example electronic devices may include, without limitation, routers, switches, media hubs, and other networking devices, microphones, amplifiers and/or the like.

As illustrated by FIG. 1, ports of a patch panel may be divided into one or more groups of ports. Each group may contain one or more ports. For example, as illustrated by FIG. 1, a top patch panel **100** may include four ports **102, 104, 106, 108**, and a bottom patch panel **110** may include six ports **112, 114, 116, 118, 120, 122**. Additional and/or alternate numbers of groups and/or ports may be used within the scope of this disclosure.

As illustrated by FIG. 1, the inter-port distances of the ports on the top patch panel **100** differ from that of the ports on the bottom patch panel **110**. As such, the resulting label strips illustrated in FIG. 1 differ for each patch panel.

FIG. 2 illustrates a flow chart of an example method of estimating patch panel measurements according to an embodiment. As illustrated by FIG. 2, an image of one or more patch panels may be received **200**. In an embodiment, an image may be a picture of a patch panel that may be captured by an imaging device. An imaging device may be a computing device configured to capture one or more images and may include, without limitation, a camera, a mobile device, a tablet, a smartphone and/or the like. In an embodiment, an image may be received from an imaging device.

In an embodiment, one or more markers may be used during the image capture process. A marker may be an electronic object that may be used to assist with alignment, position, location and/or the like of an image. In an embodiment, one or more markers may be displayed in a user interface of an imaging device. One or more markers may be provided in a user interface to allow users to align at least a portion of the image, reduce distortion of the image or change the perspective or view of an image. In an embodiment, a marker may be overlaid on a frame or screen, such as a preview screen, of an imaging device.

FIGS. 3-5 illustrate example markers according to various embodiments. FIG. 3 illustrates a marker **300** shown as a horizontal straight line segment with starting and ending points **302, 303** that are shown as two vertical lines. A user may be able to align the marker with one or more ports or patch panels by moving the marker, a start point of a marker, an end point of a marker, and/or the like. As such, a marker may be used to identify one or more ports or patch panels to be analyzed. FIG. 4 illustrates an example marker **400** depicted as a horizontal line. FIG. 5 illustrates an example marker **500** depicted as a rectangular box. In an embodiment, the size and/or aspect ratio of the box may be adjusted by a user. For example, a user may edit the box using a user interface of an imaging device. Additional and/or alternate shaped and/or sized markers may be used within the scope of this disclosure.

In an embodiment, a region of interest may be extracted **202** from the captured image. A region of interest may be extracted **202** based on the location of one or more markers. For example, a width, a height or another dimension with respect to a marker may be extracted as a region of interest. For instance, an extracted region of interest may include a portion of an image that includes a quarter of an inch from a marker in all directions. Additional and/or alternate areas may be used within the scope of this disclosure.

FIG. 6 illustrates an example region of interest extracted from the image shown in FIG. 3. As illustrated by FIG. 6, the extracted region of interest includes the patch panel corresponding to the marker **300** in FIG. 3.

Referring back to FIG. 2, in an embodiment, one or more possible port edges may be detected **204** using the region of interest. One or more possible port edges may be extracted from a region of interest using an edge detection algorithm such as, for example, a Canny edge detection algorithm, to

create an edge map. In an embodiment, an edge detection algorithm may locate one or more vertical lines or edges from an image. FIG. 7 illustrates an example edge map according to an embodiment.

A horizontal edge intensity profile may be calculated based on the edge map. In an embodiment, a column having a number of edge pixels greater than a certain threshold may be considered a vertical line. Consecutive lines may be combined to produce a final set of lines. FIG. 8 illustrates a patch panel image with detected vertical lines overlaid.

In an embodiment, one or more possible port edges may be fit **206** to a cross-ratio constancy model. Under a cross-ratio constancy model, for an image with perspective distortion, the cross ratio of certain points on an original line in three-dimensional space may be the same as the cross-ratio of certain points on a projected line. For example, FIG. 9 illustrates an original line **900** in three-dimensional space and a projected line **902**. The original line may include points A, B, C, D while the projected line may include points A', B', C', D'. In an embodiment, A', B', C', D' may be projections of points A, B, C, D, respectively.

In an embodiment, a cross-ratio constancy model may be represented by the following equation:

$$\frac{AC}{BC} \cdot \frac{AD}{BD} = \frac{A'C'}{B'C'} \cdot \frac{A'D'}{B'D'}$$

In an embodiment, a candidate gap may be identified from a region of interest. A candidate gap may represent possible space between ports of a patch panel according to an embodiment. At least one trailing edge associated with the candidate gap may be identified, and at least one leading edge associated with the candidate gap may be identified. A trailing edge may refer to an edge located to one side of a candidate gap, while a leading edge may refer to an edge located on another, opposite side of a candidate gap.

In an embodiment, two trailing edges and two leading edges may be selected for a candidate gap. FIG. 10 illustrates the image of FIG. 8 with the vertical lines labeled. In an embodiment, if the candidate gap **1000** in FIG. 10 is identified, Trailing Edge 2 **1002** and Trailing Edge 3 **1004** may be selected, and Leading Edge 4 **1006** and Leading Edge 5 **1010** may be selected.

In an embodiment, a port-to-gap-length ratio may be estimated using the selected edges. The port length in real dimension may be denoted by a, and the gap length in real dimension may be denoted as b. In an embodiment, the pixel distance or projected distance between one or more pairs of selected edges may be denoted. For example, using FIG. 10 as an example, the distance between Trailing Edge 2 **1002** and Trailing Edge 3 **1004** may be denoted as x, the distance between Trailing Edge 3 and Leading Edge 4 **1006** may be denoted by y, and the distance between Leading Edge 4 and Leading Edge 5 **1010** may be denoted by z.

In an embodiment, the real distance between one or more pairs of selected edges may be denoted. A real distance may be measured in terms of port lengths and/or gap lengths. For example, referring to FIG. 10, Trailing Edge 2 **1002** and Trailing Edge 3 **1004** has one port in between, so the real distance between Trailing Edge 2 and Trailing Edge 3 may be denoted as a. Trailing Edge 3 **1004** and Leading Edge 4 **1006** have a single gap in between, so the real distance between these two edges may be denoted as b.

5

Applying the projected distances and real distances using edges **1002**, **1004**, **1006**, **1010** to the cross-ratio constancy equation above may result in the following:

$$\frac{x+y}{y} : \frac{x+y+z}{y+z} = \frac{a+b}{b} : \frac{3a+2b}{2a+2b}$$

In an embodiment, the left side of the above equation may be denoted by an intermediate variable such as

$$p = \frac{(x+y)(y+z)}{y(x+y+z)}$$

The equation may be factored into:

$$2\left(\frac{a}{b}\right)^2 + (4-3p)\left(\frac{a}{b}\right) + 2(1-p) = 0$$

The solution to the above equation is the port-to-gap length ratio, which may be expressed as follows:

$$r = \frac{a}{b} = \frac{3p-4 + \sqrt{p(9p-8)}}{4}$$

In an embodiment, the computed port-to-gap length ratio may be used to estimate **208** edge locations for one or more edges of an area of interest. Potential vertical edge locations may be estimated by applying and solving the cross-ratio constancy equation repeatedly, given the port-to-gap-length ratio.

In an embodiment, one or more locations of the vertical lines that are detected **204** in the region of interest may be compared to one or more of the estimated edge locations. If the location of a detected vertical line is within a certain threshold distance from the location of an estimated edge location, the detected vertical line may be considered as a final port edge. If the location of a detected vertical line is outside of a certain threshold distance from the location of an estimated edge location, the detected vertical line may not be considered as a final port edge. Instead, the estimated edge location may be considered as a final port edge.

In an embodiment, one or more final port edges may be displayed **208**. For example, one or more final port edges may be displayed as an overlay to the received image. FIG. **11** illustrates example final port edges corresponding to the image shown in FIG. **10**. As illustrated by FIG. **11**, Edge 5 **1010** and Edge 6 **1012** have been rejected in the model. Instead, the model has filled in a pair of edges that are more aligned with the candidate gap.

In an embodiment, the port-to-gap-length ratio and positions of the final port edges may be refined with a least squares fitting. The port edges that have been retained after rejection may be used in a least squares type cost function. The cost function may be optimized using an optimization method to obtain a best estimate of the port-to-gap length ratio as well as positions of the final port edges.

In an embodiment, referring back to FIG. **2**, steps **206** and **208** may be repeated one or more times using different candidate gaps and corresponding pairs of leading and trailing

6

edges. The best result out of the trials may be selected as the ultimate port-to-gap-length ratio and positions of the final edges.

In an embodiment, a position, location and/or the like of one or more final ports may be estimated **210** based on one or more of the final port edges. For example, a location of a final port may be an area between two final port edges. Similarly, a position of a gap may be estimated based on one or more of the final port edges. For example, a location of a gap may be an area between a pair of final ports.

In an embodiment, information relating to the location of one or more final port edges and/or ports may be provided **212** to a print device. For example, information relating to an inter-port distance, a port-length-to-gap-length ratio and/or the like may be provided to a print device. The print device may use this information to generate an image, a print out, a document and/or like that corresponds to the patch panel illustrated in the received image. For example, a print device may generate one or more labels that correspond to the patch panel illustrated in the received image. In an embodiment, the position of one or more labels may align with the locations of one or more ports of the patch panel. For example, a print device may generate a sheet of labels where the position and dimensions of each label align with the position and dimensions of a port of a port panel.

FIG. **12** depicts a block diagram of hardware that may be used to contain or implement program instructions. A bus **1200** serves as the main information highway interconnecting the other illustrated components of the hardware. CPU **1205** is the central processing unit of the system, performing calculations and logic operations required to execute a program. CPU **1205**, alone or in conjunction with one or more of the other elements disclosed in FIG. **12**, is an example of a production device, computing device or processor as such terms are used within this disclosure. Read only memory (ROM) **1210** and random access memory (RAM) **1215** constitute examples of non-transitory computer-readable storage media.

A controller **1220** interfaces with one or more optional non-transitory computer-readable storage media **1225** to the system bus **1200**. These storage media **1225** may include, for example, an external or internal DVD drive, a CD ROM drive, a hard drive, flash memory, a USB drive or the like. As indicated previously, these various drives and controllers are optional devices.

Program instructions, software or interactive modules for providing the interface and performing any querying or analysis associated with one or more data sets may be stored in the ROM **1210** and/or the RAM **1215**. Optionally, the program instructions may be stored on a tangible non-transitory computer-readable medium such as a compact disk, a digital disk, flash memory, a memory card, a USB drive, an optical disc storage medium, such as a Blu-ray™ disc, and/or other recording medium.

An optional display interface **1230** may permit information from the bus **1200** to be displayed on the display **1235** in audio, visual, graphic or alphanumeric format. Communication with external devices, such as a printing device, may occur using various communication ports **1240**. A communication port **1240** may be attached to a communications network, such as the Internet or an intranet.

The hardware may also include an interface **1245** which allows for receipt of data from input devices such as a keyboard **1250** or other input device **1255** such as a mouse, a joystick, a touch screen, a remote control, a pointing device, a video input device and/or an audio input device.

It will be appreciated that various of the above-disclosed and other features and functions, or alternatives thereof, may be desirably combined into many other different systems or applications or combinations of systems and applications. Also that various presently unforeseen or unanticipated alter-
natives, modifications, variations or improvements therein may be subsequently made by those skilled in the art which are also intended to be encompassed by the following claims.

What is claimed is:

1. A method of estimating one or more dimensions of a patch panel, the method comprising:

receiving an image of a patch panel, wherein the patch panel comprises a plurality of ports and one or more gaps;

extracting, by a computing device, a region of interest from the received image;

detecting, by the computing device, one or more possible port edges from the region of interest;

fitting the detected possible port edges to a cross-ratio constancy model to determine a port-to-gap-length ratio associated with the patch panel;

using the port-length-to-gap-length ratio to determine a location of one or more final port edges; and

determining a location of one or more final ports based on the location of the final port edges.

2. The method of claim **1**, wherein:

receiving an image of a patch panel comprises receiving the image of the patch panel from an imaging device, wherein the image comprises a perspective distortion.

3. The method of claim **2**, further comprising:

presenting, by the imaging device, one or more markers on a user interface to assist with alignment of the image.

4. The method of claim **3**, wherein:

receiving an image of a patch panel further comprises receiving an indication of the one or more markers;

extracting a region of interest from the received image comprises extracting the region of interest based on the received indication.

5. The method of claim **1**, wherein detecting one or more possible port edges from the region of interest comprises:

applying an edge detection algorithm to the region of interest to identify one or more vertical lines; and

creating an edge map that includes the identified vertical lines.

6. The method of claim **1**, wherein fitting the detected possible port edges to a cross-ratio constancy model to determine a port-to-gap-length ratio associated with the patch panel comprises:

identifying a candidate gap from the region of interest;

identifying a first trailing edge and a second trailing edge associated with the candidate gap;

identifying a first leading edge and a second leading edge associated with the candidate gap;

determining the port-to-gap-length ratio by solving

$$\frac{AC}{BC} \cdot \frac{AD}{BD} = \frac{A'C'}{B'C'} \cdot \frac{A'D'}{B'D'}$$

where:

AC is a pixel distance between the first trailing edge and the first leading edge from the image,

BC is a pixel distance between the second trailing edge and the first leading edge from the image,

AD is a pixel distance between the first trailing edge and the second leading edge from the image,

BD is a pixel distance between the second trailing edge and the second leading edge from the image,

A'C' is a physical distance between the first trailing edge and the first leading edge,

B'C' is a physical distance between the second trailing edge and the first leading edge,

A'D' is a physical distance between the first trailing edge and the second leading edge,

B'D' is a physical distance between the second trailing edge and the second leading edge.

7. The method of claim **1**, wherein using the port-to-gap-length ratio to determine a location of one or more final port edges comprises:

determining a location of one or more estimated port edges based on the determined port-to-gap-length ratio;

for each estimated port edge:

comparing the location of the estimated port edge to a location of one or more of the possible port edges,

if the location of the estimated port edge is within a threshold distance from the possible port edge, identifying the estimated port edge as a final port edge, otherwise, identifying the possible port edge as the final port edge.

8. The method of claim **7**, further comprising generating a modified image that comprises the received image and an overlay showing the final port edges and their locations.

9. The method of claim **7**, further comprising sending information about the final port edges to a print device so that the print device prints one or more labels having positions that align with the final ports.

10. A system for estimating one or more dimensions of a patch panel, the system comprising:

a computing device; and

a computer-readable storage medium in communication with the computing device, wherein the computer-readable storage medium comprises one or more programming instructions that, when executed, cause the computing device to:

receive an image of a patch panel, wherein the patch panel comprises a plurality of ports and one or more gaps,

extract a region of interest from the received image, detect one or more possible port edges from the region of interest,

fit the detected possible port edges to a cross-ratio constancy model to determine a port-to-gap-length ratio associated with the patch panel,

use the port-length-to-gap-length ratio to determine a location of one or more final port edges, and

determine a location of one or more final ports based on the location of the final port edges.

11. The system of claim **10**, wherein the one or more programming instructions that, when executed, cause the computing device to receive an image of a patch panel comprise one or more programming instructions that, when executed, cause the computing device to receive the image of the patch panel from an imaging device, wherein the image comprises a perspective distortion.

12. The system of claim **11**, further comprising:

an imaging device in communication with the computing device, wherein the imaging device is configured to present one or more markers on a user interface to assist with alignment of the image.

13. The system of claim **10**, wherein:

the one or more programming instructions that, when executed, cause the computing device to receive an image of a patch panel comprises one or more program-

9

ming instructions that, when executed, cause the computing device to receive an indication of one or more markers;

the one or more programming instructions that, when executed, cause the computing device to extract a region of interest from the received image comprise one or more programming instructions that, when executed, cause the computing device to extract the region of interest based on the received indication.

14. The system of claim 10, wherein the one or more programming instructions that, when executed, cause the computing device to detect one or more possible port edges from the region of interest comprise one or more programming instructions that, when executed, cause the computing device to:

apply an edge detection algorithm to the region of interest to identify one or more vertical lines; and
create an edge map that includes the identified vertical lines.

15. The system of claim 10, wherein the one or more programming instructions that, when executed, cause the computing device to fit the detected possible port edges to a cross-ratio constancy model to determine a port-to-gap-length ratio associated with the patch panel comprise one or more programming instructions that, when executed, cause the computing device to:

identify a candidate gap from the region of interest;
identify a first trailing edge and a second trailing edge associated with the candidate gap;
identify a first leading edge and a second leading edge associated with the candidate gap;
determine the port-to-gap-length ratio by solving

$$\frac{AC}{BC} \cdot \frac{AD}{BD} = \frac{A'C'}{B'C'} \cdot \frac{A'D'}{B'D'}$$

where:

AC is a pixel distance between the first trailing edge and the first leading edge from the image,
BC is a pixel distance between the second trailing edge and the first leading edge from the image,

10

AD is a pixel distance between the first trailing edge and the second leading edge from the image,

BD is a pixel distance between the second trailing edge and the second leading edge from the image,

A'C' is a physical distance between the first trailing edge and the first leading edge,

B'C' is a physical distance between the second trailing edge and the first leading edge,

A'D' is a physical distance between the first trailing edge and the second leading edge,

B'D' is a physical distance between the second trailing edge and the second leading edge.

16. The system of claim 10, wherein the one or more programming instructions that, when executed, cause the computing device to use the port-to-gap-length ratio to determine a location of one or more final port edges comprise one or more programming instructions that, when executed, cause the computing device to:

determine a location of one or more estimated port edges based on the determined port-to-gap-length ratio;

for each estimated port edge:

compare the location of the estimated port edge to a location of one or more of the possible port edges,

if the location of the estimated port edge is within a threshold distance from the possible port edge, identify the estimated port edge as a final port edge, otherwise, identify the possible port edge as the final port edge.

17. The system of claim 16, further wherein the computer-readable storage medium further comprises one or more programming instructions that, when executed, cause the computing device to generate a modified image that comprises the received image and an overlay showing the final port edges and their locations.

18. The system of claim 16, wherein the computer-readable storage medium further comprises one or more programming instructions that, when executed, cause the computing device to send information about the final port edges to a print device so that the print device prints one or more labels having positions that align with the final ports.

* * * * *