



US009060096B2

(12) **United States Patent**
Munsell et al.

(10) **Patent No.:** **US 9,060,096 B2**
(45) **Date of Patent:** **Jun. 16, 2015**

(54) **METHOD AND SYSTEM FOR FORMING A CONTENT STREAM WITH CONDITIONAL ACCESS INFORMATION AND A CONTENT FILE**

21/4147 (2013.01); H04N 21/4405 (2013.01);
H04N 21/4622 (2013.01); H04N 21/6106
(2013.01); H04N 21/84 (2013.01)

(75) Inventors: **Michael R. Munsell**, Playa del Rey, CA (US); **Mitchell B. Wasden**, Redondo Beach, CA (US); **James A. Michener**, Grass Valley, CA (US); **Raynold M. Kahn**, Los Angeles, CA (US); **Maria G. Popoli**, Rancho Palos Verdes, CA (US)

(58) **Field of Classification Search**
USPC 726/26-30
See application file for complete search history.

(73) Assignee: **The DIRECTV Group, Inc.**, El Segundo, CA (US)

(56) **References Cited**

(*) Notice: Subject to any disclaimer, the term of this patent is extended or adjusted under 35 U.S.C. 154(b) by 2363 days.

U.S. PATENT DOCUMENTS

6,016,507	A	1/2000	Carroll et al.	
7,073,073	B1	7/2006	Nonaka et al.	
7,171,567	B1 *	1/2007	Bayer et al.	713/193
7,203,311	B1	4/2007	Kahn et al.	
2001/0052130	A1	12/2001	Yap et al.	
2002/0002542	A1 *	1/2002	Ando et al.	705/57
2002/0051539	A1	5/2002	Okimoto et al.	
2002/0080971	A1 *	6/2002	Fukami et al.	380/277

(Continued)

(21) Appl. No.: **11/828,601**

OTHER PUBLICATIONS

(22) Filed: **Jul. 26, 2007**

Spaliaras et al., A novel key refreshment scheme increasing the security of conditional access systems in digital satellite pay-TV, Consumer Electronics, IEEE Transactions on vol. 59, Issue: 3, Publication Year: 2013, pp. 521-527.*

(65) **Prior Publication Data**

US 2009/0028328 A1 Jan. 29, 2009

(Continued)

(51) **Int. Cl.**

G06F 7/04	(2006.01)
H04N 7/167	(2011.01)
H04N 7/16	(2011.01)
H04N 21/2347	(2011.01)
H04N 21/262	(2011.01)
H04N 21/266	(2011.01)
H04N 21/4147	(2011.01)
H04N 21/4405	(2011.01)
H04N 21/462	(2011.01)
H04N 21/61	(2011.01)
H04N 21/84	(2011.01)

Primary Examiner — Luu Pham
Assistant Examiner — Roderick Tolentino

(52) **U.S. Cl.**

CPC **H04N 7/1675** (2013.01); **H04N 7/165** (2013.01); **H04N 21/2347** (2013.01); **H04N 21/26208** (2013.01); **H04N 21/26606** (2013.01); **H04N 21/26613** (2013.01); **H04N**

(57) **ABSTRACT**

A communication system includes a content repository 274 storing a content file and a video transport processing system 273 in communication with the content repository 274. The video transport processing system 273 receives a plurality of conditional access information, stores a relative time of arrival of each of the plurality of conditional access information and encrypts the content file using the plurality of conditional access information and the relative time of arrival to form an encrypted content file.

54 Claims, 10 Drawing Sheets

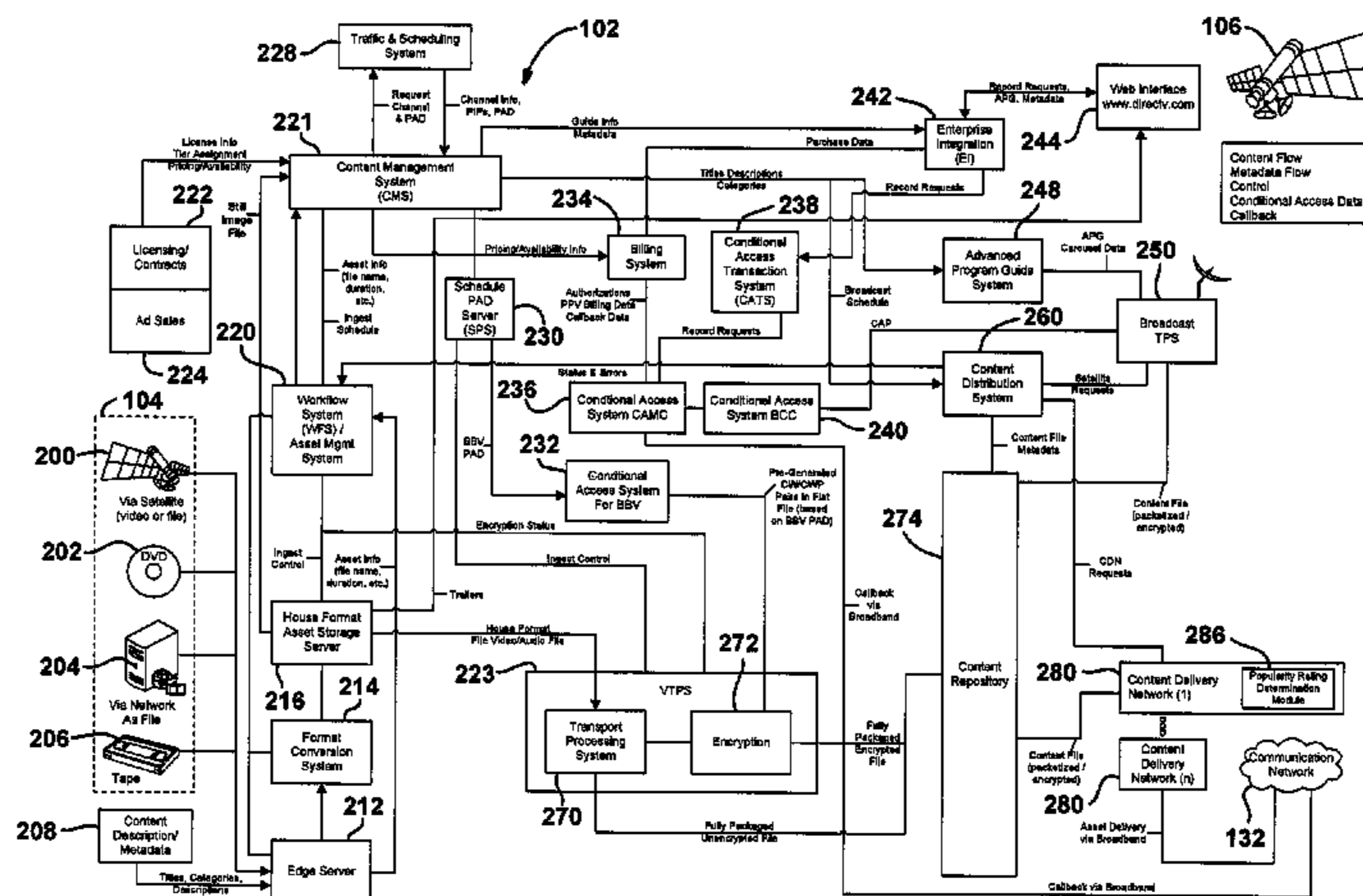

(56)

References Cited

U.S. PATENT DOCUMENTS

2002/0114465 A1* 8/2002 Shen-Orr et al. 380/231
2003/0200548 A1* 10/2003 Baran et al. 725/90
2004/0083177 A1* 4/2004 Chen et al. 705/50
2004/0133923 A1 7/2004 Watson et al.
2005/0055724 A1 3/2005 Atad et al.
2005/0097598 A1* 5/2005 Pedlow et al. 725/31
2005/0141713 A1* 6/2005 Genevois 380/239
2006/0072611 A1* 4/2006 Kamperman et al. 370/473
2006/0127037 A1 6/2006 Van Hoff et al.
2006/0136718 A1* 6/2006 Moreillon 713/155
2006/0218611 A1 9/2006 Son et al.

2007/0039028 A1 2/2007 Bar
2007/0294178 A1 12/2007 Pinder et al.
2007/0294738 A1* 12/2007 Kuo et al. 725/116
2008/0155607 A1 6/2008 Klappert
2009/0019468 A1 1/2009 Ganesan et al.
2010/0122276 A1 5/2010 Chen

OTHER PUBLICATIONS

Yang et al., The conditional access flow using subscriber smart card with Koreasat DBS receiver, Consumer Electronics, IEEE Transactions on vol. 43 , Issue: 3, Publication Year: 1997 , pp. 330-336.*

* cited by examiner

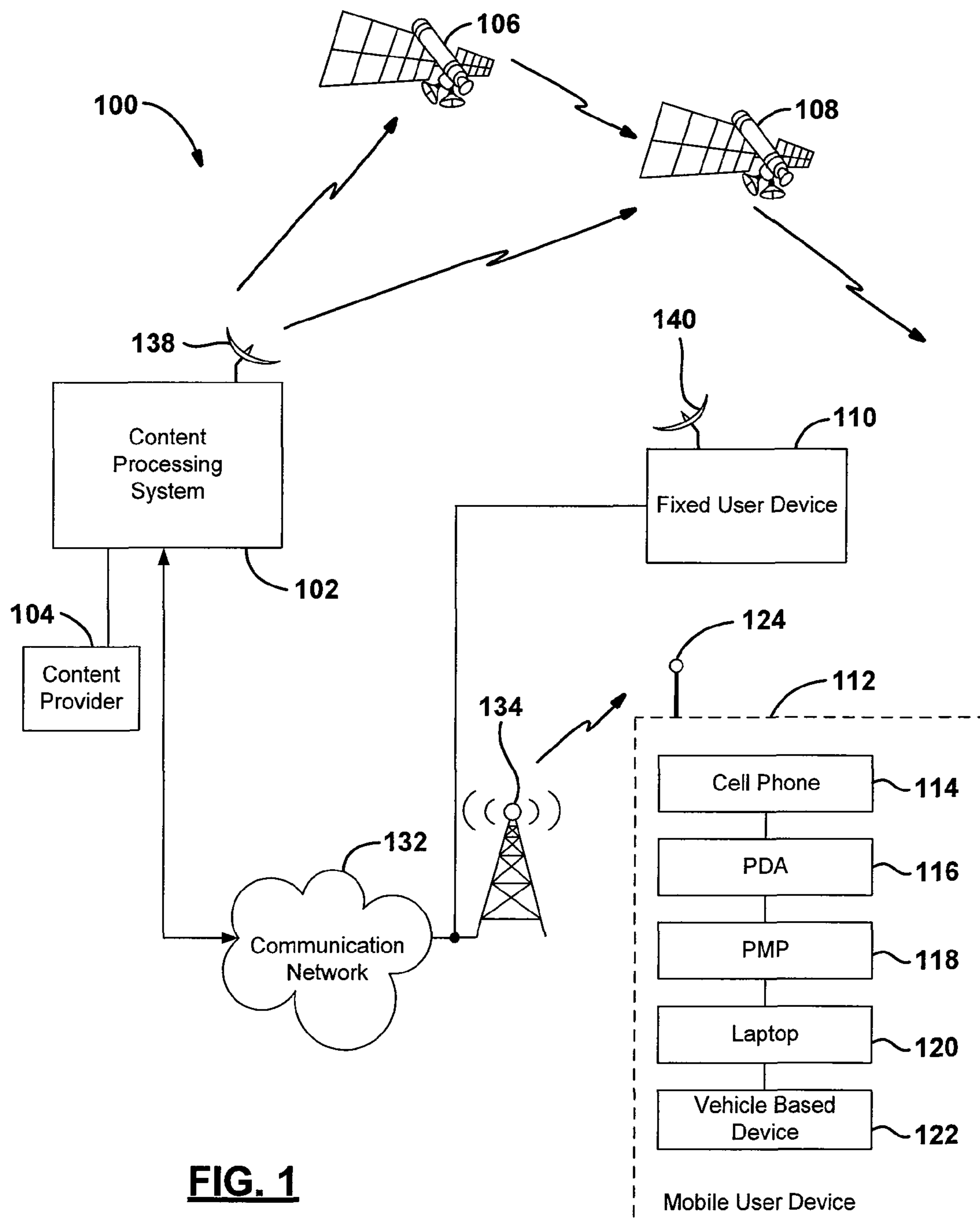

FIG. 1

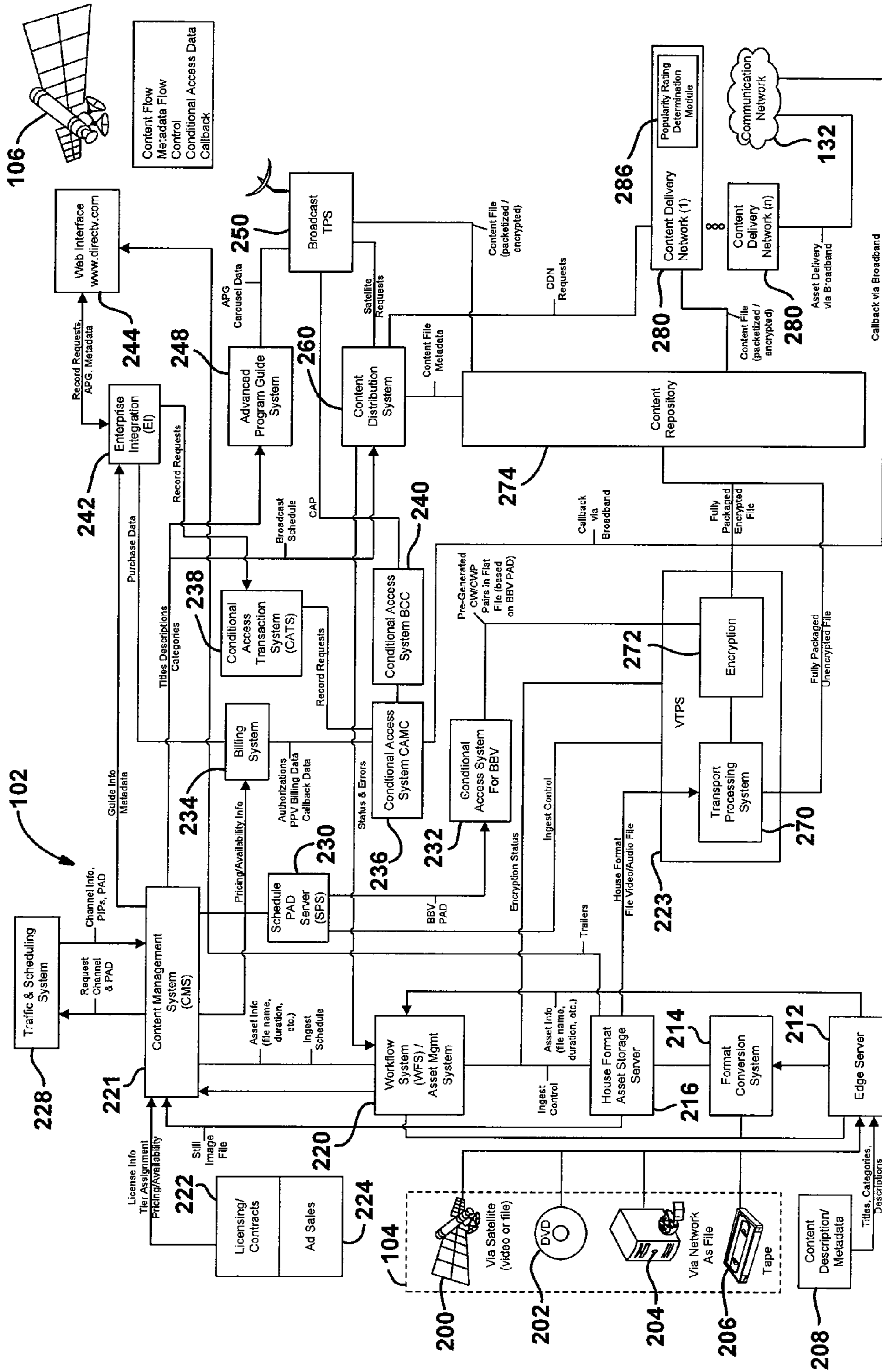

FIG. 2

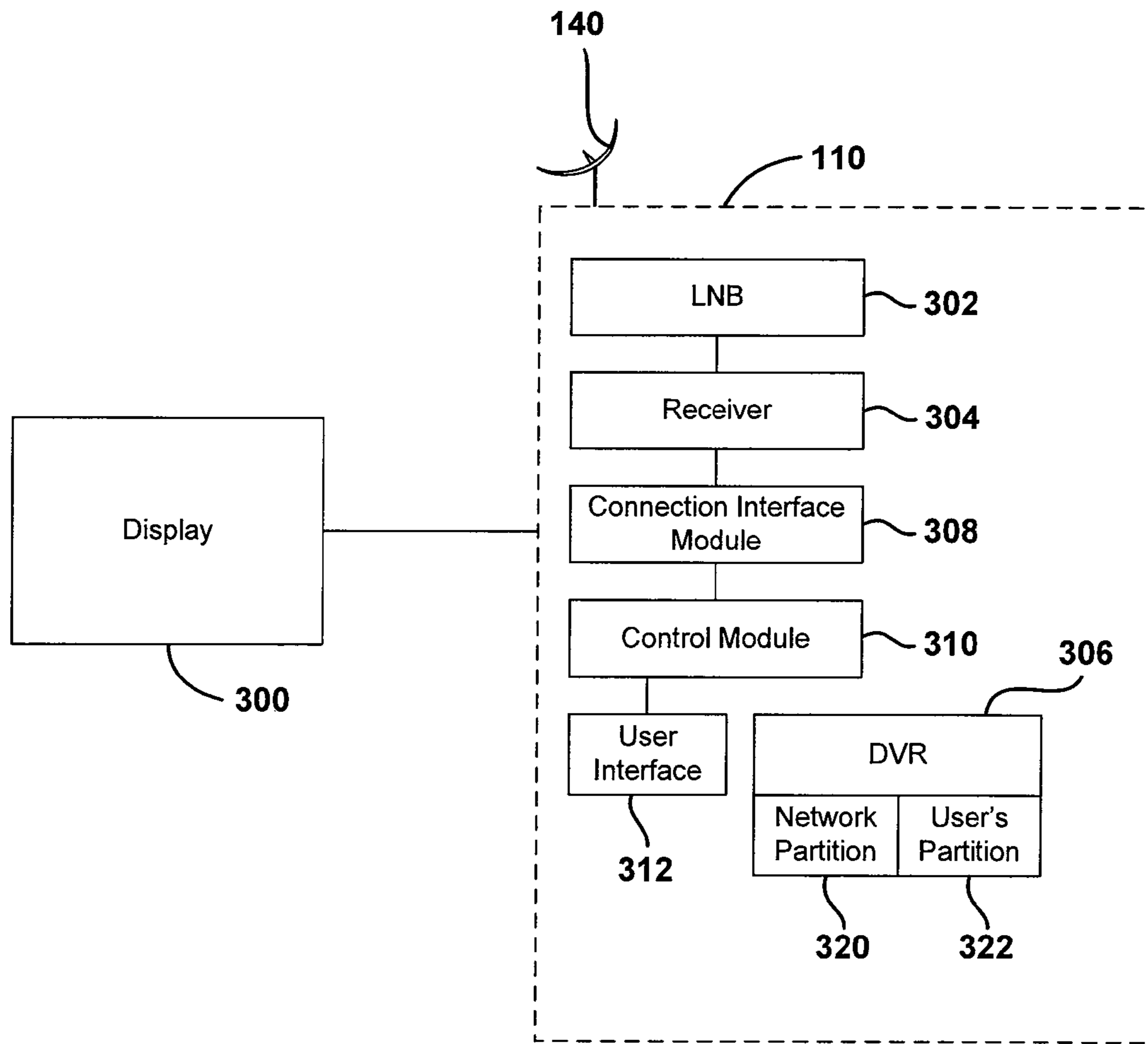

FIG. 3

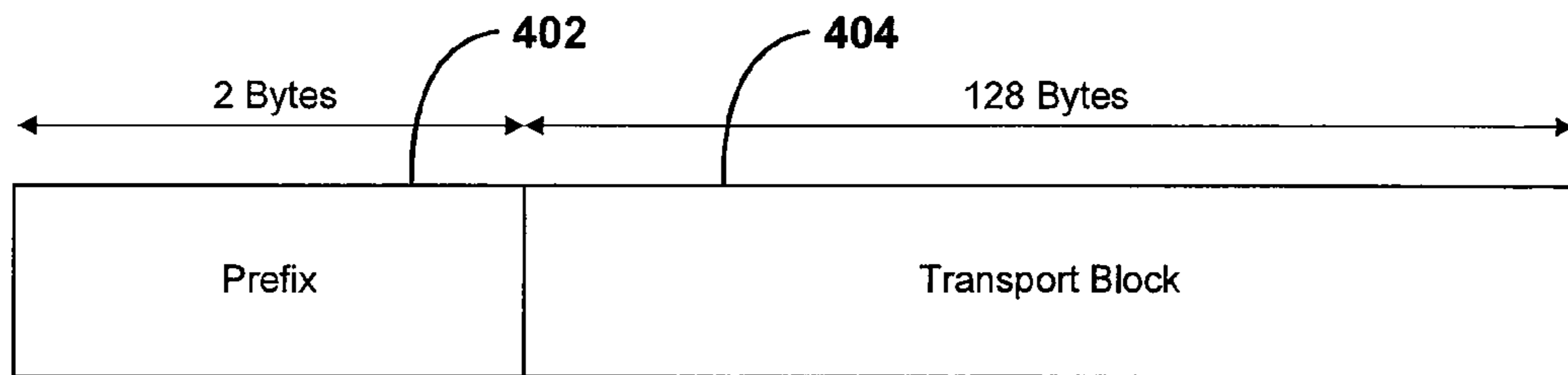

FIG. 4a

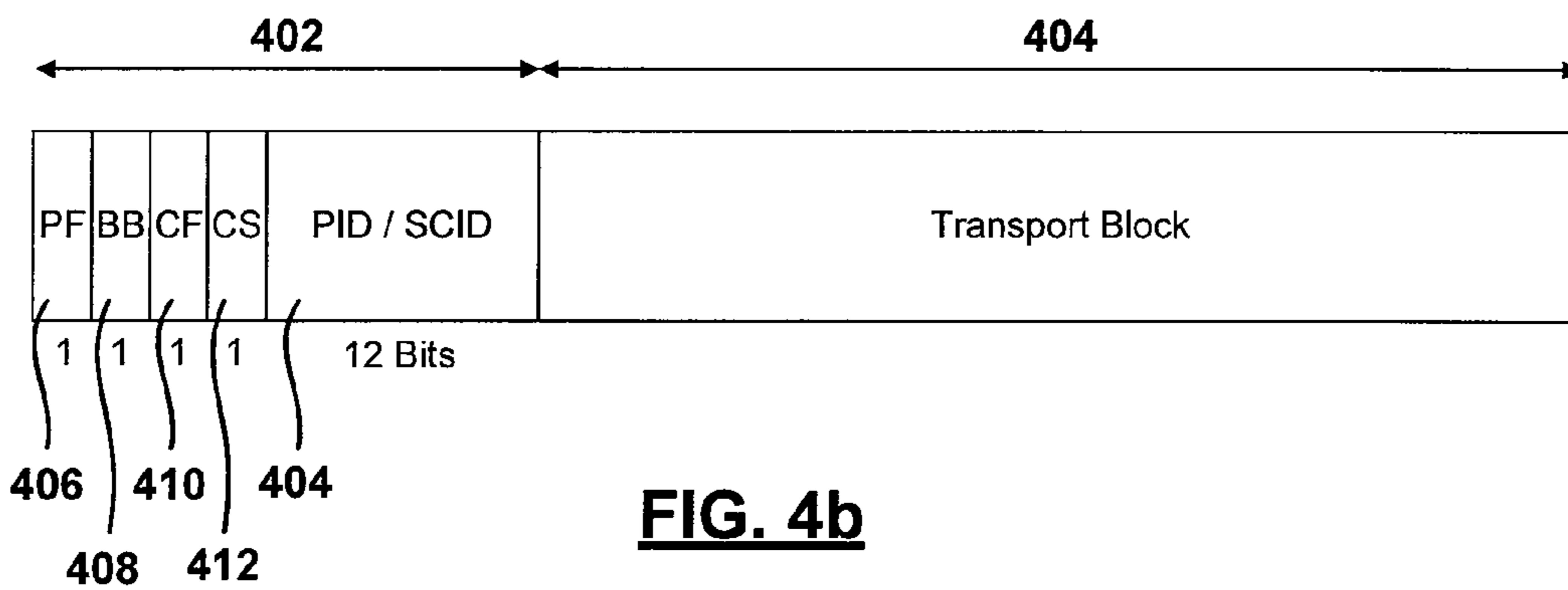

FIG. 4b

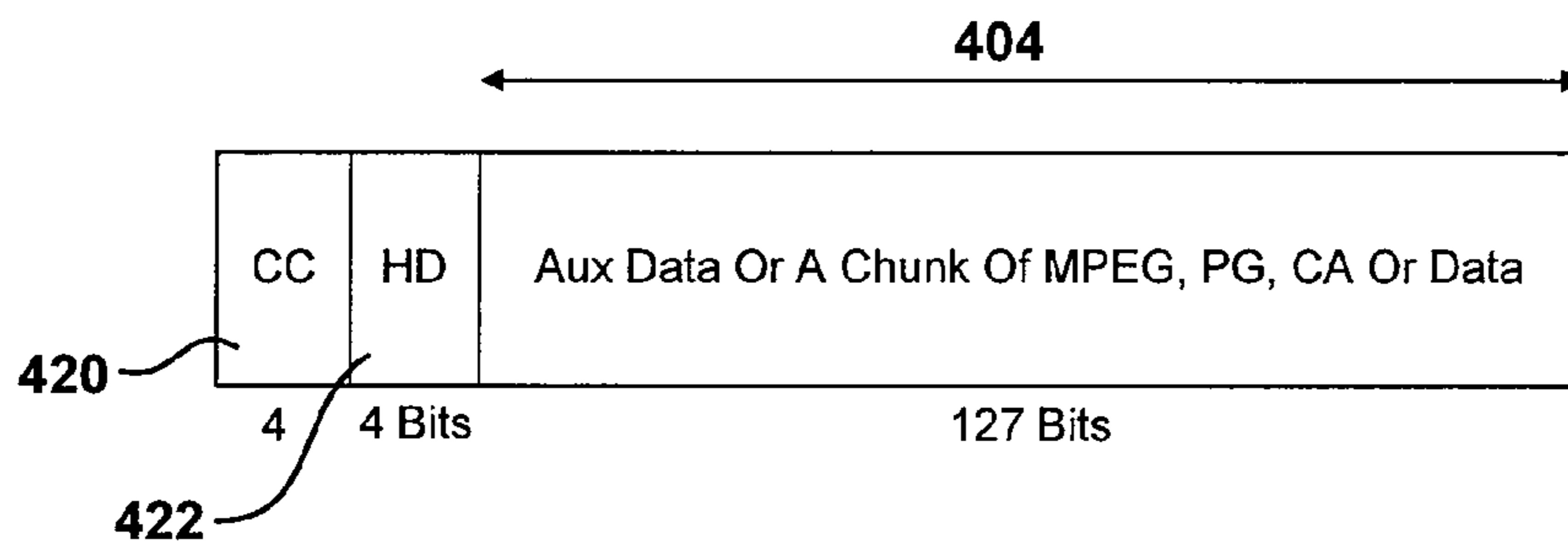

FIG. 4c

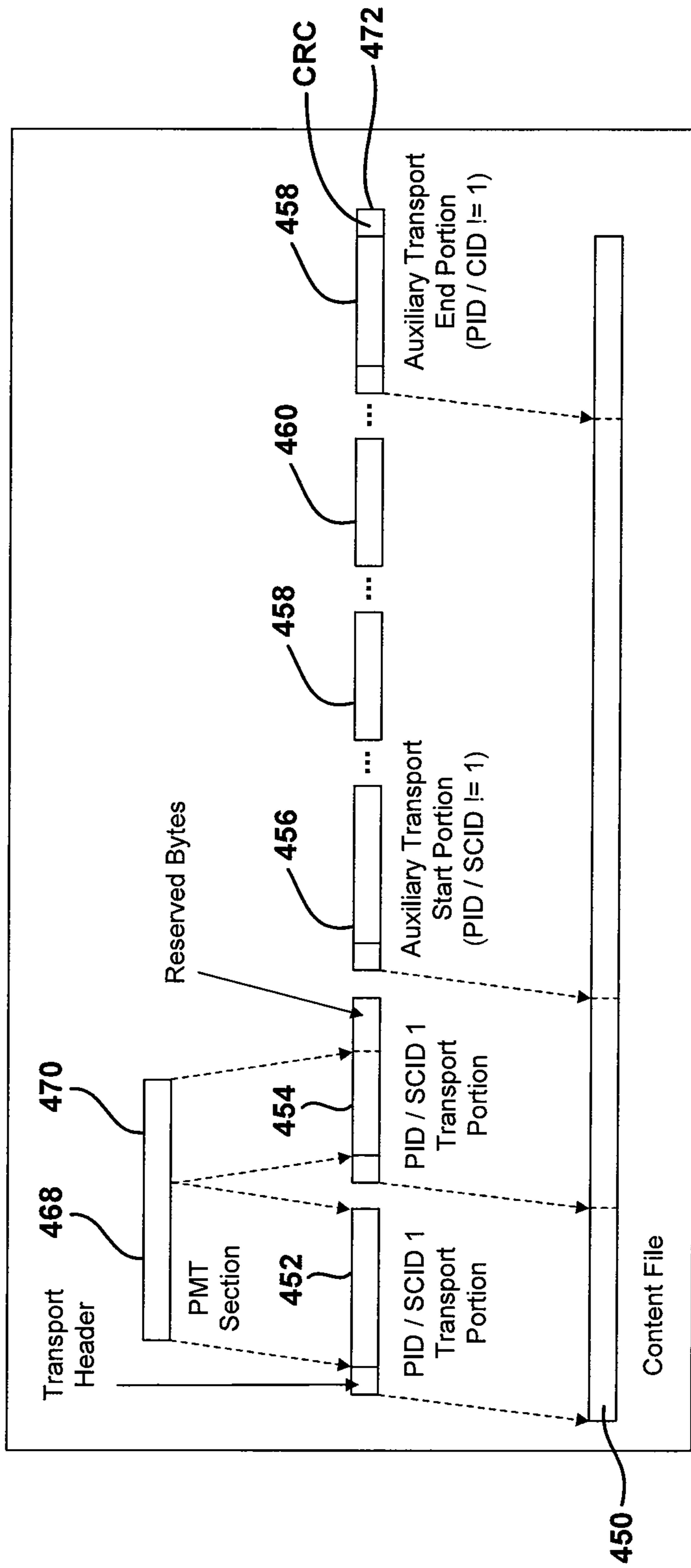

FIG. 5

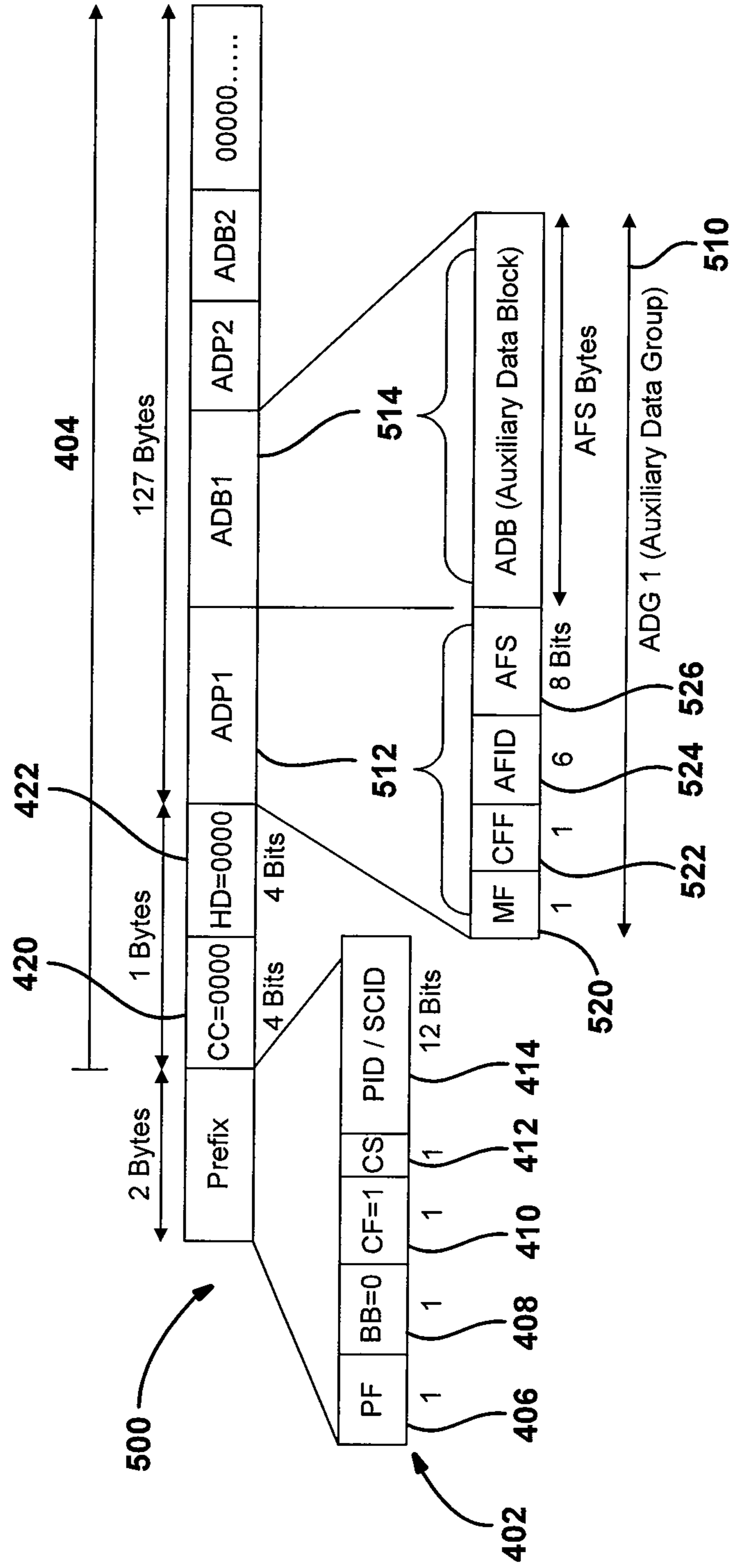

FIG. 6

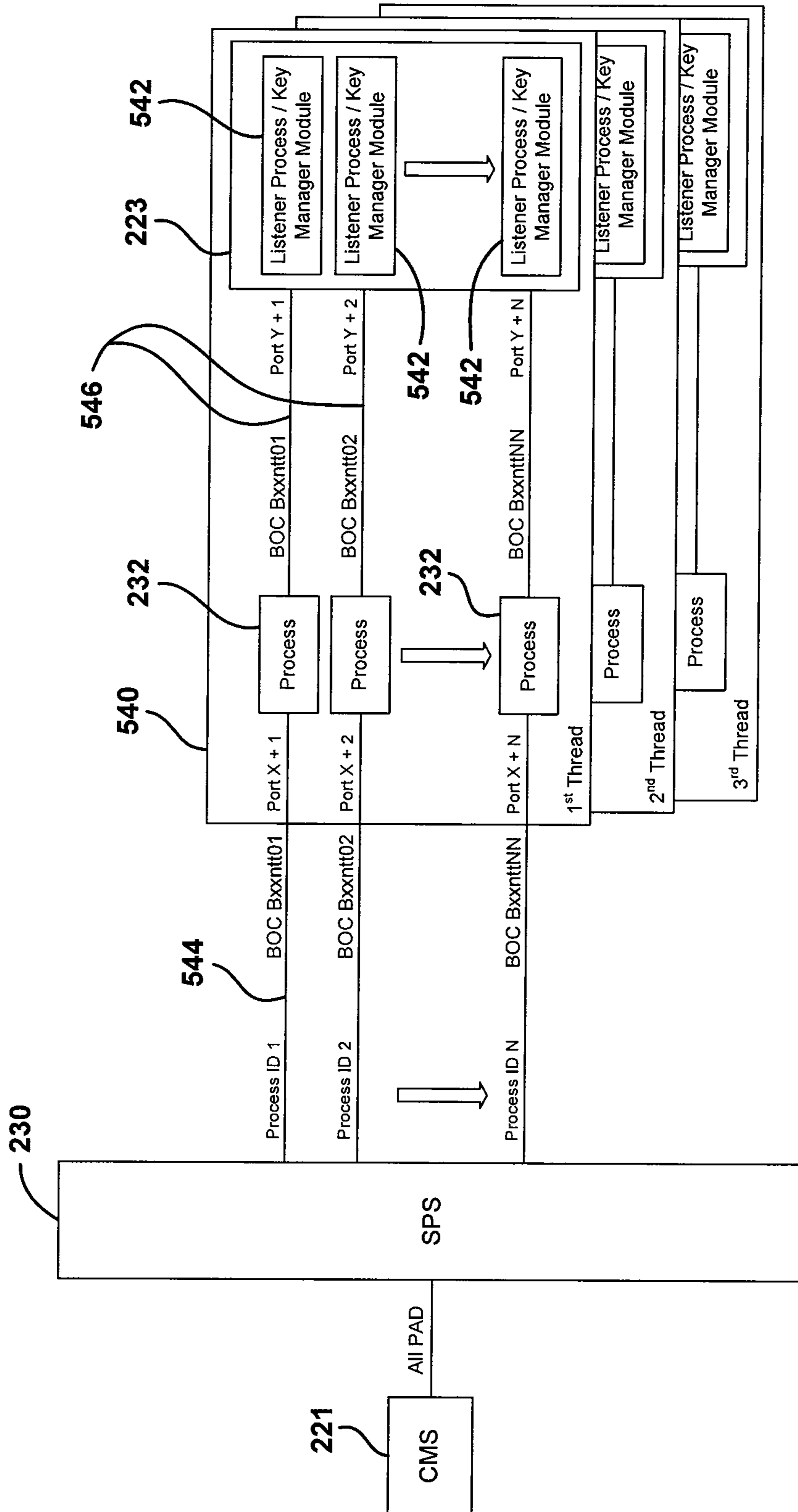

FIG. 7

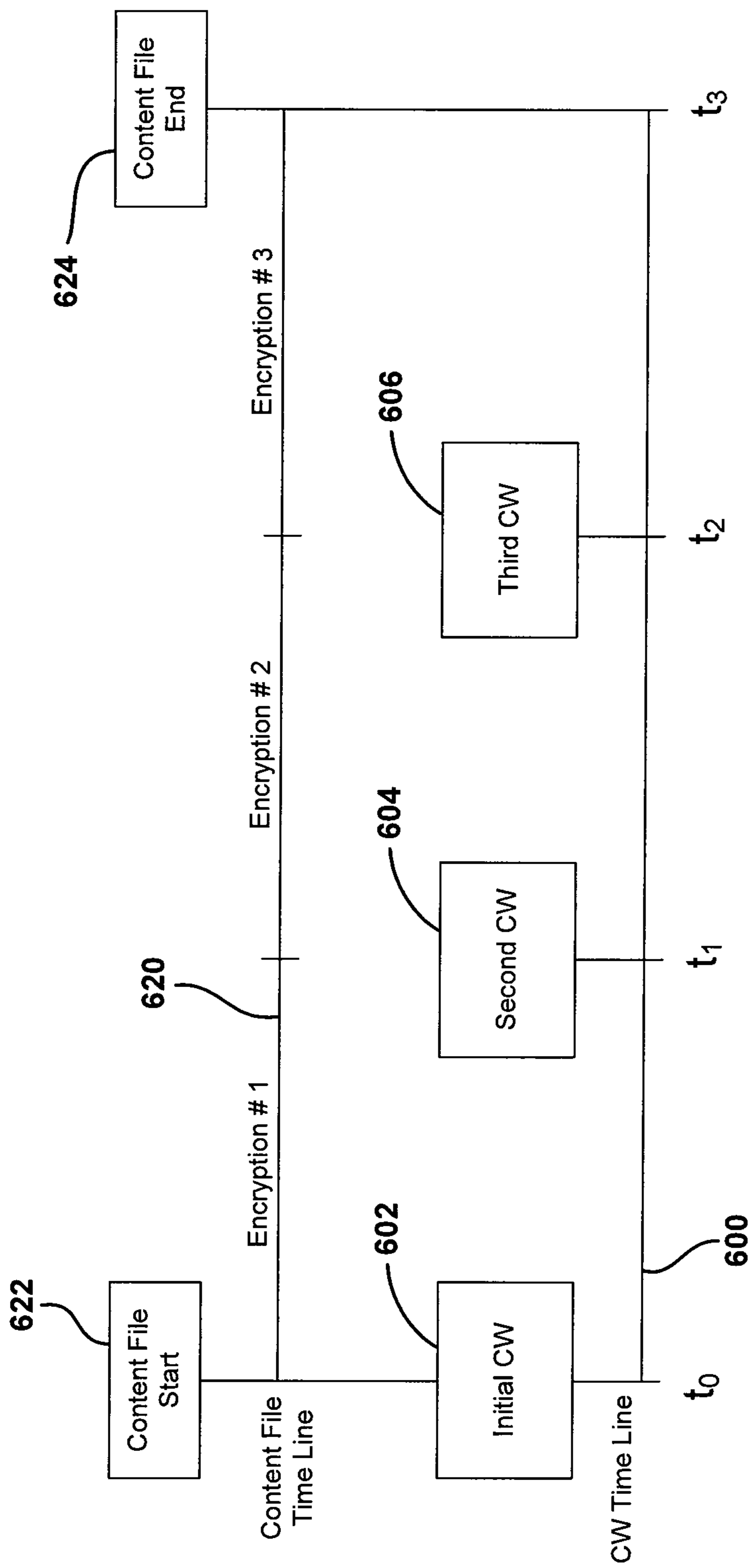

FIG. 8

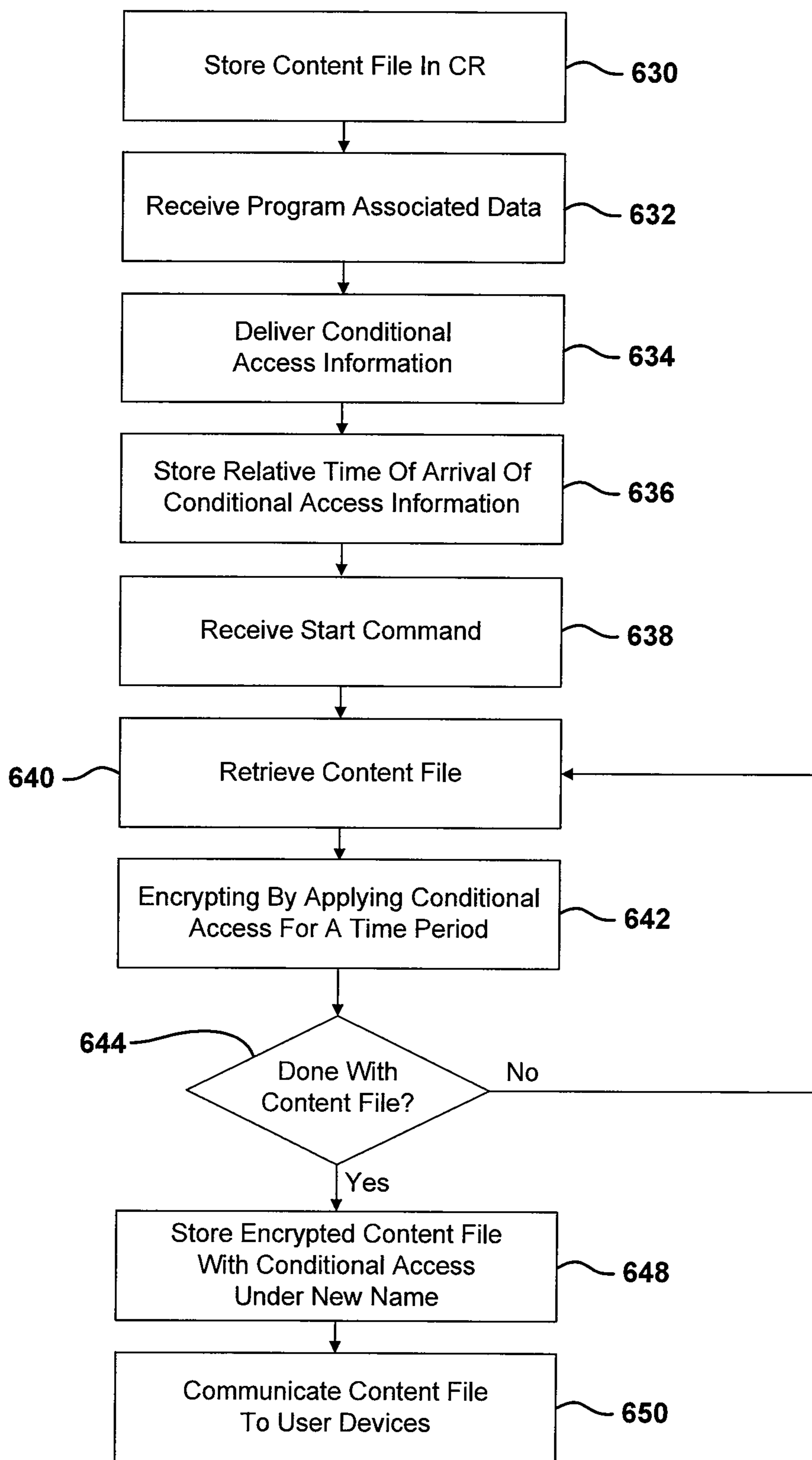
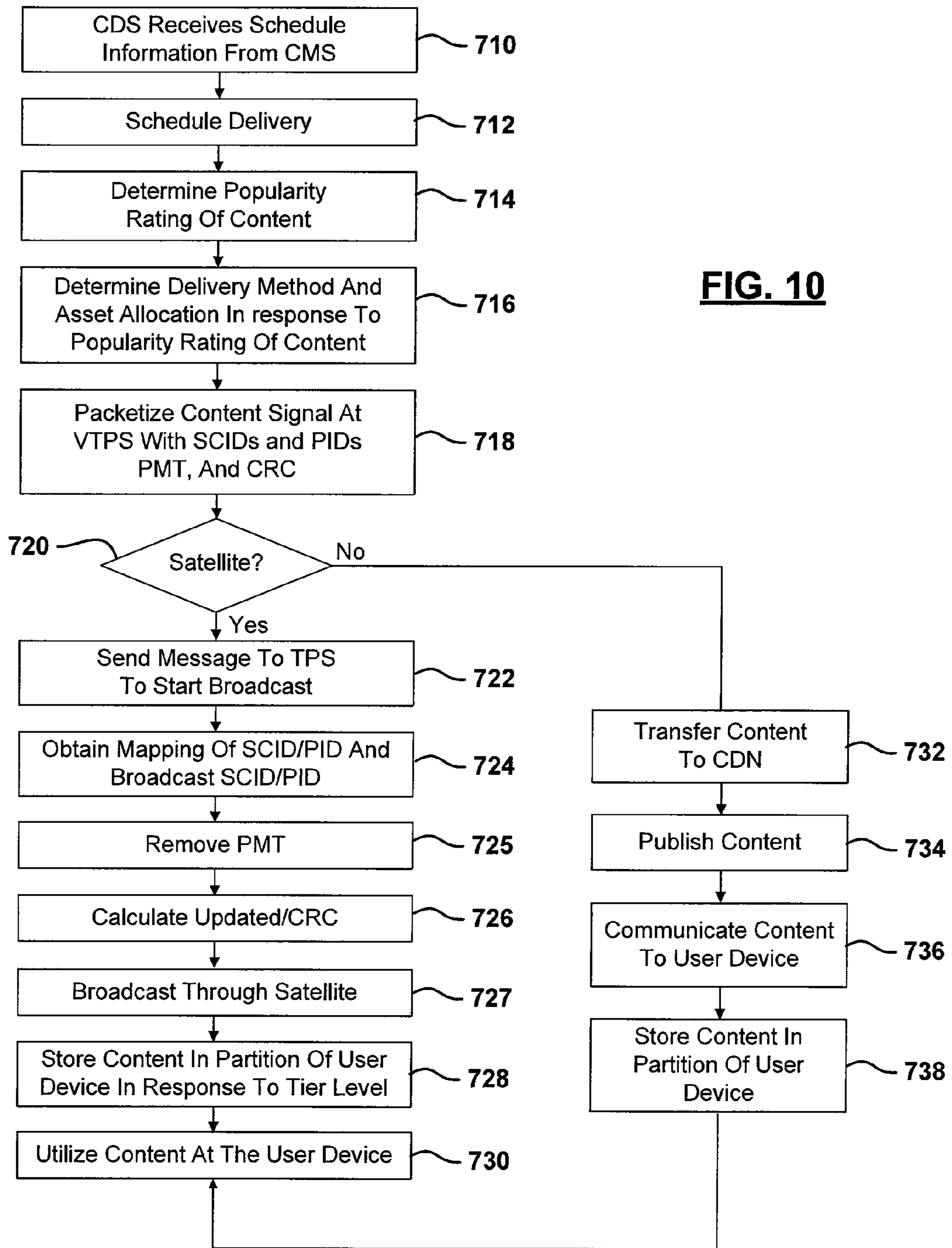

FIG. 9



1**METHOD AND SYSTEM FOR FORMING A
CONTENT STREAM WITH CONDITIONAL
ACCESS INFORMATION AND A CONTENT
FILE**

TECHNICAL FIELD

The present disclosure relates to a content processing and delivery system and, more specifically, to a system for forming a content stream using conditional access information and a content file.

BACKGROUND

The statements in this section merely provide background information related to the present disclosure and may not constitute prior art.

Satellite television has become increasingly popular due to the wide variety of content and the quality of content available. A satellite television system typically includes a set top box that is used to receive the satellite signals and decode the satellite signals for use on a television. The set top box typically has a memory associated therewith. The memory may include a digital video recorder or the like as well as the operating code for the set top box.

Satellite television systems typically broadcast content to a number of users simultaneously in a system. Satellite television systems also offer subscription or pay-per-view access to broadcast content. Access is provided using signals broadcast over the satellite. Once access is provided the user can access the particular content. The broadcasting of a large selection of channels and pay-per-view programs uses a considerable amount of satellite resources.

Content providers are increasingly trying to determine additional ways to provide content to users. Some content may be desired by a small number of customers. In such a case using valuable satellite resources at peak viewing times may not be cost effective. Less popular content may be broadcast by satellite at less popular viewing times, or may be available for downloading on demand via a broadband connection. Such content may be received and stored by a digital video recorder for later viewing.

SUMMARY

The present disclosure allows files to be easily managed within the system based upon various times, including a publication start time, a publication end time, and a purge time.

In one aspect of the disclosure, a method includes storing a content file in a content repository, communicating a plurality of conditional access information to a video transport processing system, storing a relative time of arrival of each of the plurality of conditional access information, and encrypting the content file using the plurality of conditional access information and the relative time of arrival to form an encrypted content file.

In a further aspect of the disclosure, a method includes storing a content file in a content repository, communicating to a video transport processing system first conditional access information corresponding at a first time and a second conditional access information at a second time after the first time, sequentially retrieving the content file from the content repository, and sequentially encrypting the content file using the first conditional access information for a first time period between the first time and the second time and the second conditional access information after the second time.

2

In a further aspect of the disclosure, a communication system includes a content repository storing a content file and a video transport processing system in communication with the content repository. The video transport processing system receives a plurality of conditional access information, stores a relative time of arrival of each of the plurality of conditional access information and encrypts the content file using the plurality of conditional access information and the relative time of arrival to form an encrypted content file.

Further areas of applicability will become apparent from the description provided herein. It should be understood that the description and specific examples are intended for purposes of illustration only and are not intended to limit the scope of the present disclosure.

DRAWINGS

The drawings described herein are for illustration purposes only and are not intended to limit the scope of the present disclosure in any way.

FIG. 1 is a schematic illustration of a communication system according to the disclosure.

FIG. 2 is a detailed block diagrammatic view of the content processing system of FIG. 1.

FIG. 3 is a detailed block diagrammatic view of the fixed user device of FIG. 1.

FIGS. 4A, 4B and 4C are representational views of packets formed according to the present disclosure.

FIG. 5 is a diagrammatic representation of a content file and various portions within the content file.

FIG. 6 is a diagrammatic representation of an auxiliary data packet structure that may be used for the content file of FIG. 5.

FIG. 7 is a flowchart illustrating a method for publishing and purging content.

FIG. 8 is a state diagram for publishing and purging content.

FIG. 9 is a flowchart of a method of transferring content through a satellite or a communication network according to the present disclosure.

FIG. 10 is a flowchart for communicating broadband availability data through a satellite.

DETAILED DESCRIPTION

The following description is merely exemplary in nature and is not intended to limit the present disclosure, application, or uses. For purposes of clarity, the same reference numbers will be used in the drawings to identify similar elements. As used herein, the term module refers to an Application Specific Integrated Circuit (ASIC), an electronic circuit, a processor (shared, dedicated, or group) and memory that execute one or more software or firmware programs, a combinational logic circuit, and/or other suitable components that provide the described functionality. As used herein, the phrase at least one of A, B, and C should be construed to mean a logical (A or B or C), using a non-exclusive logical OR. It should be understood that steps within a method may be executed in different order without altering the principles of the present disclosure.

The following system is described with respect to a satellite system and a broadband system. The broadband distribution system may be implemented in a cable or telephone-type system. An optical fiber may also be used in the broadband system. Wireless distribution may also be used in the broadband distribution system.

While the following disclosure is made with respect to example DIRECTV® broadcast services and systems, it

should be understood that many other delivery systems are readily applicable to disclosed systems and methods. Such systems include other wireless distribution systems, wired or cable distribution systems, cable television distribution systems, Ultra High Frequency (UHF)/Very High Frequency (VHF) radio frequency systems or other terrestrial broadcast systems (e.g., Multi-channel Multi-point Distribution System (MMDS), Local Multi-point Distribution System (LMDS), etc.), Internet-based distribution systems, cellular distribution systems, power-line broadcast systems, any point-to-point and/or multicast Internet Protocol (IP) delivery network, and fiber optic networks. Further, the different functions collectively allocated among a head end (HE), integrated receiver/decoders (IRDs) and a content delivery network (CDN) as described below can be reallocated as desired without departing from the intended scope of the present patent.

Further, while the following disclosure is made with respect to the delivery of video (e.g., television (TV), movies, music videos, etc.), it should be understood that the systems and methods disclosed herein could also be used for delivery of any media content type, for example, audio, music, data files, web pages, etc. Additionally, throughout this disclosure reference is made to data, information, programs, movies, assets, video data, etc., however, it will be readily apparent to persons of ordinary skill in the art that these terms are substantially equivalent in reference to the example systems and/or methods disclosed herein. As used herein, the term title will be used to refer to, for example, a movie itself and not the name of the movie.

Referring now to FIG. 1, a communication system 100 includes a content processing system 102 that is used as a processing and transmission source, a plurality of content providers, one of which is shown at reference numeral 104 and a first satellite 106. A second satellite 108 may also be incorporated into the system. The satellites 106, 108 may be used to communicate different types of information or different portions of various contents from the content processing system 102. The system 100 also includes a plurality of fixed user devices 110 such as integrated receiver/decoders (IRDs). Wireless communications are exchanged between the content processing system 102 and the fixed user devices 110 through one or more of the satellites 106, 108. The wireless communications may take place at any suitable frequency, such as, for example, Ka band and/or Ku-band frequencies.

A mobile user device 112 may also be incorporated into the system. The mobile user device 112 may include, but is not limited to, a cell phone 114, a personal digital assistant 116, a portable media player 118, a laptop computer 120, or a vehicle-based device 122. It should be noted that several mobile devices 112 and several fixed user devices 110 may be used in the communication system 100. The mobile devices 112 may each have a separate antenna generally represented by antenna 124.

In addition to communication via the satellites 106, 108, various types of information such as security information, encryption-decryption information, content, or content portions may be communicated terrestrially. A communication network 132 such as the public switched telephone network (PSTN), a terrestrial wireless system, stratospheric platform, an optical fiber, or the like may be used to terrestrially communicate with the fixed user device 110 or the mobile user device 112. To illustrate the terrestrial wireless capability an antenna 134 is illustrated for wireless terrestrial communication to the mobile user device 112.

Information or content provided to content processing system 102 from the media source 104 may be transmitted, for

example, via an uplink antenna 138 to the satellite(s) 106, 108, one or more of which may be a geosynchronous or geostationary satellite, that, in turn, rebroadcast the information over broad geographical areas on the earth that include the user devices 110, 112. The satellites may have inter-satellite links as well. Among other things, the example content processing system 102 of FIG. 1 provides program material to the user devices 110, 112 and coordinates with the user devices 110, 112 to offer subscribers pay-per-view (PPV) program services and broadband services, including billing and associated decryption of video programs. Non-PPV (e.g. free or subscription) programming may also be received. To receive the information rebroadcast by satellites 106, 108, each for user device 110 is communicatively coupled to a receiver or downlink antenna 140.

Security of assets broadcast via the satellites 106, 108 may be established by applying encryption and decryption to assets or content during content processing and/or during broadcast (i.e., broadcast encryption). For example, an asset can be encrypted based upon a control word (CW) known to the content processing system 102 and known to the user devices 110, 112 authorized to view and/or playback the asset. In the illustrated example communication system 100, for each asset the content processing system 102 generates a control word packet (CWP) that includes, among other things, a time stamp, authorization requirements and an input value and then determines the control word (CW) for the asset by computing a cryptographic hash of the contents of the CWP. The CWP is also broadcast to the user devices 110, 112 via the satellites 106, 108. The user devices authorized to view and/or playback the broadcast encrypted asset will be able to correctly determine the CW by computing a cryptographic hash of the contents of the received CWP. If the user device 110 is not authorized, the IRD 110 will not be able to determine the correct CW that enables decryption of the received broadcast encrypted asset. The CW may be changed periodically (e.g., every 30 seconds) by generating and broadcasting a new CWP. In an example, a new CWP is generated by updating the timestamp included in each CWP. Alternatively, a CWP could directly convey a CW either in encrypted or unencrypted form. Other examples of coordinated encryption and decryption abound, including for example, public/private key encryption and decryption.

Referring now to FIG. 2, the content processing system 102 of FIG. 1 is illustrated in further detail. The content provider 104 may include various types of content providers, including those that provide content by way of a satellite 200, DVD 202, via a network as a file in 204, by way of tapes and other means. The content provider 104 may also provide a content description and other metadata 208 to the system. An input server 212 may receive the various content and associated metadata and convert the format in a format conversion system 214. A house format asset storage server 216 may be used to store the content asset in a house format. Still image files, trailers, and other information may also be stored in the house format asset storage server. A workflow management system 220 is used to control the format conversion system 214 and the server 212. Also, the workflow management system 220 is coupled to the house format asset storage server 216 and performs ingest control. The house format asset storage server 216 provides still images to a content management system 221 and house format file, video and audio files to the video transport processing system 223.

The VTPS 223 may encode the packets containing the content. The encoder may encode the data into various transport formats such as DIRECTV® proprietary formats, or industry standard formats. The encoded data is then pack-

etized into a stream of data packets by a packetizer **270** that also attaches a header to each data packet to facilitate identification of the contents of the data packet such as, for example, a sequence number that identifies each data packet's location within the stream of data packets (i.e., a bitstream). The header also includes a program identifier (PID) (e.g., a service channel identifier (SCID)) that identifies the program to which the data packet belongs.

The stream of data packets (i.e., a bitstream) is then broadcast encrypted by, for example, the well-known Advanced Encryption Standard (AES) or the well-known Data Encryption Standard (DES). In an example, only the payload portion of the data packets are encrypted thereby allowing a user device **110** to filter, route and/or sort received broadcast encrypted data packets without having to first decrypt the encrypted data packets.

The content management system **221** generally controls the overall movement and distribution of contents through the content processing system **102**.

A licensing and contract information **222** and ads from ad sales **224** may be provided to the content management system **221**. That is, licensing information, tier assignments, pricing and availability may be provided to the content management system. Asset information, file names and durations may be exchanged between the content management system **221** and the workflow management system **220**. The asset information, such as file names and durations, may be determined at the server **212** that is coupled to the workflow management system **220**.

The Content Management System (CMS) **221** in combination with the SPS (**230**) is used to provide the requested channel, program associated data (PAD), channel information and program information packets (PIPs). The CMS **221** may schedule content processing for a plurality of received assets based on a desired program lineup to be offered by the communication system **100**. For example, a live TV program for which a high demand for reruns might be expected could be assigned a high priority for content processing.

A schedule PAD server (SPS) **230** may be coupled to the CMS and is used to generate a broadband video PAD that is communicated to a conditional access system for broadband video **232**. The conditional access system for broadband video **232** may be used to generate control words and control word packet in pairs and provide those to the video transport processing system **223**.

In the illustrated example of FIG. 2, users of the user devices **110** (of FIG. 1) are charged for subscription services and/or asset downloads (e.g., PPV TV) and, thus, the content processing system **102** includes a billing system **234** to track and/or bill subscribers for services provided by the system **100**. For example, the billing system **234** records that a user has been authorized to download a movie and once the movie has been successfully downloaded the user is billed for the movie. Alternatively, the user may not be billed unless the movie has been viewed.

A billing system **234** receives pricing and availability information from the content management system **221**. A conditional access system **236** receives callback information from the communication network **132**. The conditional access system may be used to generate authorizations, pay-per-view billing data, and callback data from the billing system **234**. Remote record requests may also be provided from the conditional access transaction system **238**. A conditional access system BCC **240** may be used to generate a conditional access packet from the information from the conditional access system **236**.

The billing system **234** may generate purchase data that is provided to the enterprise integration (EI) block **242**. The enterprise integration block **242** may generate remote record requests to the conditional access transaction system **238**. Remote record requests may be generated through a web interface such as DIRECTV.com® in block **244**. Various ordering information, such as ordering broadband video, pay-per-view, and various services may be received at the web interface **244**. Various trailers may also be accessed by the users through the web interface **244** provided from the house format asset storage server **216**. Enterprise integration block **242** may also receive guide information and metadata from the content management system **221**.

Titles, description and various categories from the content management system **221** may be provided to the advanced program guide system **248**. The program guide system **248** may be coupled to a satellite broadcasting system such as a broadcast transport processing system **250** that broadcasts content to the users through the satellite **106, 108**.

The program guide data generated by the program guide system **248** may include information that is used to generate a display of guide information to the user, wherein the program guide may be a grid guide and informs the user of particular programs that are broadcast on, particular channels at particular times. A program guide may also include information that a user device uses to assemble programming for display to a user. For example, the program guide may be used to tune to a channel on which a particular program is offered. The program guide may also contain information for tuning, demodulating, demultiplexing, decrypting, depacketizing, or decoding selected programs.

Content files may also be provided from the content management system **221** to the content distribution system **260**.

Referring back to the video transport processing system **223**, the video transport processing system **223** includes a transport packaging system **270**. The transport processing system **270** creates pre-packetized unencrypted files. An encryption module **272** receives the output of the transport processing system and encrypts the packets. Fully packaged and encrypted files may also be stored in the content repository **274**. Encryption may take place in the data portion of a packet and not the header portion.

One or more content delivery networks **280** may be used to provide content files such as encrypted or unencrypted and packetized files to the communication network **132** for distribution to the user devices **110, 112**. The content distribution system **260** may make requests for delivery of the various content files and assets through the communication network **132**. The content distribution system **260** also generates satellite requests and broadcasts various content and assets through the broadcast transport processing system **250**.

The communication network **132** may be the Internet **122** which is a multiple-point-to-multiple-point communication network. However, persons of ordinary skill in the art will appreciate that point-to-point communications may also be provided through the communication network **132**. For example, downloads of a particular content file from a content delivery network may be communicated to a particular user device. Such file transfers and/or file transfer protocols are widely recognized as point-to-point communications or point-to-point communication signals and/or create point-to-point communication paths, even if transported via a multi-point-to-multi-point communication network such as the Internet. It will be further recognized that the communication network **132** may be used to implement any variety of broadcast system where a broadcast transmitter may transmit any variety of data or data packets to any number of or a variety of

clients or receivers simultaneously. Moreover, the communication network **132** may be used to simultaneously provide broadcast and point-to-point communications and/or point-to-point communication signals from a number of broadcast transmitters or content delivery networks **280**.

The content delivery network **280** may be implemented using a variety of techniques or devices. For instance, a plurality of Linux-based servers with fiber optic connections may be used. Each of the content delivery networks **280** may include servers that are connected to the Internet or the communication network **132**. This allows the user devices to download information or content (example, a movie) from the content delivery network **280**. The content delivery network **280** may act as a cache for the information provided from the content repository **274**. A particular user device may be directed to a particular content delivery network **280** depending on the specific content to be retrieved. An Internet uniform resource locator (URL) may be assigned to a movie or other content. Further, should one of the delivery networks **280** have heavy traffic, the content delivery network may be changed to provide faster service. In the interest of clarity and ease of understanding, throughout this disclosure reference will be made to delivering, downloading, transferring and/or receiving information, video, data, etc. by way of the content delivery network **280**. However, persons of ordinary skill in the art will readily appreciate that information is actually delivered, downloaded, transferred, or received by one of the Internet-based servers in or associated with the content delivery network **280**.

It should be appreciated that the content delivery network **280** may be operated by an external vendor. That is, the operator of the content delivery network **280** may not be the same as the operator of the remaining portions of the content processing system **102**. To download files from the content delivery network **280**, user devices **110**, **112** may implement an Internet protocol stack with a defined application layer and possibly a download application provided by a content delivery network provider. In the illustrated example, file transfers are implemented using standard Internet protocols (file transfer protocol FTP), hyper text transfer protocol (HTTP), etc. Each file received by the user device may be checked for completeness and integrity and if a file is not intact, missing, and/or damaged portions of the files may be delivered or downloaded again. Alternatively, the entire file may be purged from the IRD and delivered or downloaded again.

The broadcast transport processing system **250** may provide various functions, including packetizing, multiplexing and modulating, and uplink frequency conversion. RF amplification may also be provided in the broadcast transport processing system **250**.

Wireless delivery via the satellites **106**, **108** may simultaneously include both files (e.g., movies, pre-recorded TV shows, games, software updates, asset files, etc.) and/or live content, data, programs and/or information. Wireless delivery via the satellites **106**, **108** offers the opportunity to deliver, for example, a number of titles (e.g., movies, pre-recorded TV shows, etc.) to virtually any number of customers with a single broadcast. However, because of the limited channel capacity of the satellites **106**, **108**, the number of titles (i.e., assets) that can be provided during a particular time period is restricted.

In contrast, Internet-based delivery via the CDN **280** can support a large number of titles, each of which may have a narrower target audience. Further, Internet-based delivery is point-to-point (e.g., from an Internet-based content server to a user device **110**, **112**) thereby allowing each user of the user device **110**, **112** to individually select titles. Allocation of a

title to satellite and/or Internet-based delivery or content depends upon a target audience size and may be adjusted over time. For instance, a title having high demand (i.e., large initial audience) may initially be broadcast via the satellites **106**, **108**, then, over time, the title may be made available for download via the CDN **280** when the size of the target audience or the demand for the title is smaller. A title may simultaneously be broadcast via the satellites **106**, **108** and be made available for download from the CDN **280** via the communication network **132**.

In the example communication system **100**, each asset (e.g., program, title, content, game, TV program, etc.) is pre-packetized and, optionally, pre-encrypted and then stored as a data file (i.e., an asset file). Subsequently, the asset file may be broadcast via the satellites **106**, **108** and/or sent to the CDN **280** for download via the CDN **280** (i.e., Internet-based delivery). In particular, if the data file is broadcast via the satellites **106**, **108**, the data file forms at least one payload of a resultant satellite signal. Likewise, if the data file is available for download via the CDN **280**, the data file forms at least one payload of a resultant Internet signal.

It will be readily apparent to persons of ordinary skill in the art that even though at least one payload of a resultant signal includes the data file regardless of broadcast technique (e.g., satellite or Internet), how the file is physically transmitted may differ. In particular, transmission of data via a transmission medium (e.g., satellite, Internet, etc.) comprises operations that are: (a) transmission medium independent and b) transmission medium dependent. For example, transmission protocols (e.g., transmission control protocol/Internet protocol (TCP/IP), user datagram protocol (UDP), encapsulation, etc.) and/or modulation techniques (e.g., quadrature amplitude modulation (QAM), forward error correction (FEC), etc.) used to transmit a file via Internet signals (e.g., over the Internet **122**) may differ from those used via satellite (e.g., the satellites **106**, **108**). In other words, transmission protocols and/or modulation techniques are specific to physical communication paths, that is, they are dependent upon the physical media and/or transmission medium used to communicate the data. However, the content (e.g., a file representing a title) transported by any given transmission protocol and/or modulation is agnostic of the transmission protocol and/or modulation, that is, the content is transmission medium independent.

The same pre-packetized and, optionally, pre-encrypted, content data file that is broadcast via satellite may be available for download via Internet, and how the asset is stored, decoded and/or played back by the user devices **110** is independent of whether the program was received by the user devices **110** via satellite or Internet. Further, because the example content processing system **102** of FIG. **1** broadcasts a live program and a non-live program (e.g., a movie) by applying the same encoding, packetization, encryption, etc., how a program (live or non-live) is stored, decoded and/or played back by the user devices **110** is also independent of whether the program is live or not. Thus, user devices **110**, **112** may handle the processing of content, programs and/or titles independent of the source(s) and/or type(s) of the content, programs and/or titles. In particular, example delivery configurations and signal processing for the example content delivery system of FIG. **2** are discussed in detail below.

The content delivery network **280** may also be used to count the number of times a particular content has been requested for download. A popularity rating determination module **286** may be included in the content delivery network **280**. The popularity determination module **286** ultimately provides a popularity rating to the content management sys-

tem **221**. Of course, the popularity rating determination module **286** may generate a count and the content management system may generate a count of the number of downloads and provide that to the content management system **221**. Each content delivery network **280** may provide the popularity rating or count to the content management system **221**. The content management system **221** may combine the counts from several control delivery networks **280**.

The content management system **221**, in response to the information from the popularity rating determination module **286**, may be used to assign a satellite category or a broadband category to each of the plurality of content files. The popularity rating may also be used to allocate assets of the satellite to the distribution of content through the satellite **106**. The asset allocation of the satellite may depend upon various conditions. The satellite includes a particular bandwidth or "pipe" that is used for uplinking of material or content. Some of the bandwidth of the satellite is typically used for live broadcast. Another portion of the satellite may be used for broadband satellite distribution. The portion of the satellite broadband distribution asset may be referred to as the pipe or the broadband pipe which indicates it is other than the live or real time content. The overall pipe may be divided into several pipes or subpipes and used for various numbers of content. From the list of the content corresponding to popularity ratings, several of the broadband content files may be distributed at any particular time. If one item of the broadband content is very popular, more resources may be allocated to that particular content. The bigger the pipe associated with the content, the less time it takes a user to download the content. However, less bandwidth will be available to other types of content. Therefore, the allocation of the pipe may be based upon several things, including the size of a content file, the popularity rating, the number of pipes and the pipe size. System requirements may cause the pipe size pipe number to vary over time. For example, the schedule of broadband content to be downloaded may be changed periodically. The broadband content schedule may be changed once a day or several times a day.

It is beneficial to provide popular content over the satellite to reduce the burden of the broadband terrestrial-based communication network. Terrestrial-based communication may be more expensive in certain situations. Therefore, popular items may be broadcast through the satellite while less popular content may be broadcast through the communication network **132**. Thus, based upon the popularity, the satellite or the communication network **132** may be chosen. Thereafter, the satellite assets may also be allocated based upon the popularity of various content.

Referring now to FIG. 3, the user device **110** may be one of any variety of devices, for example, a set-top box, a home media server, a home media center (HMC), a personal computer (PC) having a receiver card installed therein, etc. A display device **300** such as a television set, a computer monitor, a portable media player or the like may be coupled to the user device. The user device **110** may be an integrated receiver decoder, a satellite television receiver or the like for displaying and/or playback of received programming.

The receive antenna **140** (**124** on a mobile device) receives signals conveying a modulated multiplexed bitstream from the satellites **106**, **108**. Within the receive antenna **140**, the signals are coupled from a reflector and feed to a low-noise block (LNB) **302**, which amplifies and frequency downconverts the received signals. The LNB **302** output is then provided to a receiver **304**, which receives, demodulates, depacketizes, demultiplexes, decrypts and decodes the received signal to provide audio and video signals to the display device

300 or a recorder **306**, or both. The memory device **306** may be implemented separately from or within the user device **110**. The receiver **304** is responsive to user inputs to, for example, tune to a particular program.

To store received and/or recorded programs and/or assets, the memory device **306** may include any of a variety of storage devices such as a hard disk drive, DVR, or other types of memory devices. The memory device **306** may be used to store the packetized assets and/or programs received via the satellites **106**, **108** and/or the CDN **280**. In particular, the packets stored on memory device **306** may be the same encoded and, optionally, encrypted packets created by the content processing system **102** and transmitted via the satellites **106**, **108** and/or made available for download via the CDN **280**.

The memory device **306** may also be a device capable of recording information on, for instance, analog media such as videotape or computer readable digital media such as a hard disk drive (HDD), a digital versatile disc (DVD), a compact disc (CD) and/or any other suitable media.

To communicate with any of a variety of clients, media players, etc., the illustrated example the user device **110** includes one or more connection interface modules **308** (e.g., USB, serial port, Firewire, etc.). The connection interface module **306** may act as a network interface that implements, for example, an Ethernet interface.

Each user device **110** may connect to the communication network such as the Internet **122** via any of a variety of technologies, for instance, a voice-band and/or integrated services digital network (ISDN) modem connected to a conventional PSTN, a wireless broadband connection (e.g., IEEE 802.11b, 802.11g, etc.), a broadband wired connection (e.g., ADSL, cable modems, etc.), a wired Ethernet connection (e.g., local area network (LAN), wide area network (WAN), etc.), a leased transmission facility (e.g., a digital signal level 1 circuit (a.k.a. a DS1), a fractional-DS1, etc.), etc.

The user device **110** may also include a control module **310** that is used to control the operation of the various components within the user device.

A user interface **312** may, for example, be a set of push buttons or a remote control interface. The user interface **312** is used to make selections, input various data, and change the parameters of the user device **110**. The user interface **312** may be used together with a graphical user interface displayed on the display device associated with the user device.

It should also be noted that the user devices **114** (device **110**) may be configured in a similar manner to those illustrated in FIG. 3 through reference number **110**. Such devices may include an internal antenna rather than an external dish-type antenna that is illustrated in the fixed device as **140**. Also, external antennas are possible such as a phased array antenna.

The recording device **306** may also be partitioned into a network partition **320** and a user partition **322**. Different types of content or assets may be stored in the network partition **320** or the user partition **322**. The content stored in the different partitions may relate to the tier of the content. This will be further described below.

Referring now to FIG. 4A, a packet **400** is illustrated having a prefix or header portion **402** and a data transport block **404**. As illustrated, the prefix portion is two bytes and the transport block is 128 bytes. Of course, various sizes of prefixes in transport blocks may be used depending on the particular system needs. The packet **400** may also represent a data field as will be described below. The transport layer is used for providing robust video delivery over a satellite channel or through a communication network. The packet length may be fixed to provide error detection, logical resynchroni-

zation, and error concealment at a receiving device. As will be described further below, the transport protocol may include two distinct sublayers: a data-link/network sublayer and an adaptation sublayer. The data link/network sublayer provides generic transport services such as scrambling control flags, a synchronous cell multiplexing, and error control. The adaptation layers designed for efficient packeting of variable length MPEG data into fixed length cells while providing rapid logical resynchronization and error concealment support at a decoder when uncorrectable error events take place.

Referring now to FIG. 4B, the prefix or header 402 is illustrated in further detail. In this example, if a prefix includes four bits of control information and 12 bits for an identification such as a program identification or service channel identification. The service multiplexing capabilities may support various types of video, audio and data services. In one embodiment, only the transport block 404 is encrypted, while the prefix or header 402 is not encrypted.

The prefix 402 includes a packet framing bit 406 that toggles between zero and one with each packet. A bundled boundary bit 408 may also be included in the prefix 402. The bundled boundary bit 408 may communicate different information depending on the type of video service. For example, standard definition video may include a bundled boundary bit of "1" when non-auxiliary video data is present in the transport block 404. For high definition, a 1 may indicate that a packetized elementary stream (PES) may be included in the transport stream but not necessarily as the first byte. A value of zero that does not include a packetized elementary stream (PES) does not have a PES start code.

The prefix 402 may also include a control flag bit 410 to indicate that the transport block may be scrambled or not scrambled.

The prefix 402 may also include a control sync bit 412 that indicates a key use for descrambling. If an auxiliary packet payload contains a control word packet (CWP), this bit indicates which CWP-derived scrambling key may be used to descramble the service packets with the same control sync as that of the auxiliary packet. For example, the key obtained from an auxiliary packet with CS=0 is used for descrambling transport packets with CS=0.

The PID/SCID block 414 may be used to uniquely identify the application for which the information in the transport packet's block it is intended. Some PID/SCID numbers may be reserved for specific purposes. For example, 0x000 may signify a null packet and other combinations may represent other important information if required by the system.

Referring now to FIG. 4C, the transport block 404 is illustrated in further detail. The transport block may include auxiliary data packets or video service packets containing formatted video data such as MPEG data. To indicate different cell types, the video transport layer format may include four bits for a continuity counter 420 and a header designator 422. The continuity counter 420 allows a receiver to detect cell discontinuity due to cell errors for a particular transport service. In one example, a packet on a particular service channel identifier may be incremented by one in each packet. After the continuity counter 420 reaches a maximum value of 15, the continuity counter 420 may wrap to 0000b. When the header designator 422 contains 0000b, auxiliary data may be indicated which allows the continuity checker to spend incrementation and resume after an auxiliary data packet is not present. The header designator may be in the format 01X0b to indicate that a video service packet is provided. As mentioned above, an auxiliary data packet may include 0000b as a header designator for auxiliary packets.

Referring now to FIG. 5, a representation of a content file 450 that is ultimately communicated as a content stream is indicated. The content file may have various portions illustrated by the two layers above the content file. The content file may be converted by the VTPS 223 into a plurality of transport portions 452, 454, 456, 458, 460, and 462.

The transport portions 452 and 454 may include a program map table (PMT) in the transport block that is indicated by reference numerals 468 and 470. The program mapped table may define all the PIDs utilized in the content file. A PID or SCID of one may indicate the packet or portion is a program mapped table. As illustrated in FIG. 5, the first two transport portions include the program map table. The PMT may be removed when communicating the content file or stream through a satellite but retained when communicating over a terrestrial communication system such as a broadband network.

The other portions of the content file may include an auxiliary start portion at 456 and auxiliary end portion at 462. The contents of the auxiliary data files will be described below. It should be noted that the auxiliary end portion file may include a cyclic redundancy check (CRC) 472.

Several other content packets may be included such as packets 458 and 460. Packets 458 and 460 merely represent two of several packets that a content file may be divided into.

Referring now to FIG. 6, an auxiliary data packet structure 500 is illustrated. The packet 500 may include a prefix portion 402 similar to that described above and correspondingly labeled. The prefix portion may include the packet framing portion 406, the bundled boundary portion 408, the control flag portion 410, the control sync portion 412, and the PID/SCID portion 414. The transport portion 404 may include 128 bytes as described above in FIGS. 4A-4C. The transport portion may include the continuity counter 420 and the header designator 422. As mentioned above, an auxiliary portion may include the continuity counter value of 0000b. The header designator may include the value 0000b.

The auxiliary data structure may include an auxiliary data group 510. The auxiliary data group may contain reference time stamps, encryption control word packets (CWPs), time code and group of picture (GOP) map data, broadband video data, and secure video processor control data packets. Reference time stamps may be used to synchronize the encoder with the decoder in a receiver. The encryption control word packet contains keys with which scrambled application packets are descrambled. The packets may be transmitted without scrambling as indicated by CF=1. If a control word packet (CWP) is contained in the auxiliary data group 510, the control sync within the same packet will indicate which key is contained in the auxiliary data group. The receiver may use the control sync that is transmitted in the application packet to determine which key shall be used to decrypt the transport block. A complete key is 64 bits long but may be hidden inside the 120 byte control word packet. The conditional access smart card in the user device may extract a key from the control word packet and send it to a decoder which uses the key to descramble the transport packet. Auxiliary data packets 514 containing control word packets are transmitted redundantly but change at a transition to a new scrambling key. As indicated by a toggle of the CS bit in the prefix 402. Time code data and SVP control data may not be in the first auxiliary packet transmitted in a new key period. The CS bit for the non-CWP packets may reflect the key sense for the key period in which they are contained. The auxiliary data group 510 may include an auxiliary data prefix 512 having two bytes and an auxiliary data block 514 that may be variable in length. An auxiliary packet may contain one or more auxiliary data

groups placed next to each other. Should the payload not be completely filled with auxiliary data group data, the remaining bytes may be filled with zeros. The auxiliary data prefix may include several bits of information, including a modifiable flag **520**. In one constructed embodiment, this bit was always set to one. However, this flag may be reserved for subsequent use. In block **522**, a current field flag (CFF) may indicate whether a valid auxiliary data group is present. For example, if this bit is one, the auxiliary data group may contain valid data. If the bit is set to zero, the remainder of the packets starting immediately after the current field flag may be ignored.

The auxiliary data prefix **512** may also include an auxiliary field identification (AFID) **524**. The AFID **524** may be used to identify the auxiliary data group. Reference time stamp and control word packet auxiliary data groups may co-exist in the same auxiliary data packet with control word only packets. The combination of bits may indicate deprecated, encryption control word packet only, reference time stamp and control word packet information, time code/GOP map data, SVP control data, broadband video data, and the like.

The auxiliary data prefix **512** may also include an auxiliary field size (AFS) block **526** that contains the length of the following auxiliary data block in bytes.

In the case of an encryption control word packet only, the AFID bit may be set to 00001, the AFS **526** may be set to 120, and the control word packet may include various information for managing encryption and conditional access. For a reference time stamp, and control word packet, the AFID may be 000011 and the AFS may be at 125. The auxiliary data block may include a byte of all zeros followed by 32 bits that represent a sample from a reference clock at the encoder. This may, for example, be taken as the time the auxiliary data packet left the encoder. The control word packet may then follow. When the AFID is 000100 and the AFS is 125, the auxiliary data block may indicate time code and GOP map packet. Various fields, including a picture-type field, may be included, such as I-picture, P-picture, and B-picture values. Time code may also be formatted in sequence such as hours, minutes, bit markers, seconds, and frames. The GOP map may indicate the GOP picture length and a bit map.

A secure video processor control data packet may include control data for secure video processor-protected content.

Should the AFID **524** and AFS **526** indicate that a broadband video packet is present, various types of information may be included in the auxiliary data block **514**. The broadband video auxiliary packet conveys information about a broadband video content file. When the content file is delivered via a broadcast transport stream, the first and last packets of the content file may be broadband packets as illustrated in FIG. **5** by reference numerals **456** and **462**. When a content file is delivered via other means, such as file transfer over the internet, the first non-PMT packet of the content file and the last packet of the content file may be broadband video auxiliary packets. Auxiliary data block may include various information, including a start of file indication. This field indicates whether this auxiliary packet is the first or last transport packet of the file. When set to a one, it is the first transport packet of the file, and when set to zero, it is the last transport packet of the file. A material ID link may also be included in bytes. A material ID indicates the content material ID. Each byte represents a character. There may be several reserve bytes within the auxiliary data block **514** for broadband video packets.

A cyclical redundancy check which may be a 32-bit value may also be provided. The cyclical redundancy check (CRC) may be calculated over every byte of the packet that makes up

the content file, including the broadband video auxiliary packets at the start and end of the file. One suitable location for the CRC information may be the last four bytes of a content file. Therefore, the result of the CRC is over the entire content file and will be zero when the file does not contain any transmission errors. When received at a receiving device, the CRC, if not matching, may be used to generate an error signal or request a retransmission of the file to the IRD or user device. This will be further described below.

The auxiliary data packets may also be video service packets. The video may be scrambled or unscrambled. If scrambled, the CR flag may be set to zero for the indication. Video may be high definition or standard definition video.

Referring now to FIG. **7**, a detailed block diagrammatic view of the elements of the present disclosure is set forth. The same reference numerals from FIG. **2** are used for the same components. In FIG. **7**, the content management system **221** generates program-associated data (PAD). The program-associated data is communicated from the content management system **221** to the schedule pad server **230**. The program-associated data may include process ID. The process ID may also be assigned at the SPS **230**. The process ID may correspond to a process in the conditional access system **232**. Various processes may be simultaneously run for keeping track of the conditional access information. The communication corresponding to a broadcast operations channel may be communicated from the schedule pad server **230** to the conditional access process within the conditional access system **232**. Various identifiers may be provided. Identifier xx may refer to the type of ingestion automation, and may refer to the processing type, tt may be referred to the video transport processing system number if a number of them are provided, and pp which are the last two digits of the broadcast operation channel may refer to the process ID within the conditional access system **232**. Various numbers of threads **540** may be provided in the system. Each of the threads may be configured with multiple processes within the conditional access system **232**. Each conditional access system receives the program-associated data and conveys the conditional access information to the VTPS **223**. The VTPS **223** may include a listener process/key manager module **542**. A separate listener process/key manager module **542** may be provided for each corresponding process in the conditional access system **232**. As will be described below, the listener process/key manager module **542** receives a plurality of conditional access information. From the first piece of conditional access information, the relative timing may be determined so that the conditional access may be applied to a content file stored within the content repository **274**.

In FIG. **7**, the operation of the CMS **221**, the SPS **230**, the conditional access system **232**, and the listener process **542** may occur in real time. That is, the systems may be adapted for receiving information, such as the conditional access information, in a real, relative time. The relative time may be determined from the receipt of the first piece of conditional access information such as a control word or an ECM. The mapping of the broadcast operation channels **544** correspond to separate conditional access processes **232**. The individual processes may also be mapped to an individual VTPS port **546**. Various types of transport formats may be supported by the VTPS, including an advanced format or a legacy format. As will be described below, a PMT and PID/SCIDs may be generated in the transport streams of the VTPS. The PMT may carry conditional access descriptors to specify the ECM-PIDs in the output file.

Referring now to FIG. **8**, two time lines of the process in the first timeline **600**, the initial control word or conditional

access information is received at time T_0 in box 602. At time T_1 , a second control word 604 is received. At time 606, a third control word is received. The control word times T_1 and T_2 are relative to time T_0 . In this example, three time periods are set forth between times T_0 and T_1 , T_1 and T_2 , and between T_2 and an ending time T_3 . The initial time and the relative arrival time of each of the control words may be stored in the VTPS 272. The control word information may be stored in a hard drive or in a cache. The upper timeline 620 illustrates encryption during the three different time periods. The timeline 620 corresponds to a content file. A content file start in box 622, the content file may be received at the VTPS 223 from the content repository 274. The content file start 622 corresponds to the initial control word 602. During the period from T_0 to T_1 , a first encryption is provided to the packets according to the initial control word. At time two, a second encryption is provided in place of the first encryption. At time T_2 , a third encryption is provided in place of the second encryption. Thus, the relative times of receipt of the code of the control words corresponds to the times the encryption changes during processing of the content files. Once the files have been encrypted and packetized, the files are stored in the content repository 274 for later distribution through the satellite 106 or the communication network 132. A start command may initiate the process corresponding to the content. It should also be noted that the processing of the file may happen after the conditional access information has been received. That is, the VTPS 223 may start receiving and caching conditional access information. Thereafter, the content file to be processed may be read from the content repository and processed. The processing may take place in greater than real time, so that if the entire conditional access information has been completed, the content file may be processed entirely. It is also possible for the conditional access information to be received partially and the VTPS system may run at great than real time until the encryption process catches up to that portion of the content file.

Referring now to FIG. 9, the system receives a file and stores a content file in the content repository 274 illustrated in FIG. 2. The content file may be received through various content providers 104. The format of the content file stored in the content repository may be in various formats, including a generic "house" format.

In step 632, program-associated data (PAD) may be received at the content management system 221. The program-associated data may be provided to the schedule pad server 230. The schedule pad server 230 may communicate the program-associated data to the conditional access system 232. The conditional access information within the program-associated data may be provided to the VTPS 222 in step 634. The conditional access system 232 may provide the conditional access information in a real time basis. Therefore, the relative time of arrival of the first piece of conditional access information and is stored and also subsequent conditional access information may also be stored in the VTPS in step 636.

In step 638, a start command that identifies the process identification and the material identification of the content to process may be received. The VTPS may verify that it has started receiving or has already received the corresponding conditional access information such as a key. The file originally stored in the content repository may be referred to as the source file. Receiving the start command is performed in step 638.

In step 640, the content file or source file is retrieved from the content repository 274 in step 640 if it is available. Errors may be generated by the system if the content source file is not available.

In step 642, encrypting may be performed by applying the conditional access information for a time period. As was illustrated in FIG. 8, an initial control word or key may be used for the initial encryption during a first time period. In step 644, if the end of the content file has not been reached, steps 640 and 642 are performed. That is, the retrieving of the content file may be continually retrieved until the end of the file. The file may be retrieved sequentially. At time periods corresponding to each of the received conditional access information, the encryption will be changed. If additional control words or conditional access information is received at times later than the end of the content file at T_3 , these control words or conditional access information will be discarded. If all of the time is not accounted for with control words, the last control word would be used to the end of the content file in box 624 of FIG. 8.

Referring back to step 644, if the content file is complete, step 648 is performed. The encrypted content file with the conditional access may be stored under a new name within the content repository. In step 650, the content file may be communicated the various user devices through a broadband communication system. The encrypted content file may be broadcast over the satellite 106 of FIG. 2 or communicated through the communication network 132 of FIG. 2.

It should be also noted that if a keychain is not used within an amount of time, the VTPS may purge them from its memory. The series of keys or control words may be stored in the VTPS as a keychain for a particular output file. The keychain may refer to a corresponding output file. The output file that the keychain is associated with may correspond to a particular file in the content repository 274.

Referring now to FIG. 10, once the content files are encrypted and packetized, the communication system 100 may communicate content through a satellite or through a communication network 132 such as the Internet. The method of FIG. 8 illustrates one way to determine which method may be used. In step 710, the content delivery system receives scheduled information from the content management system 220. In step 712, delivery is scheduled. In step 714, a tier level of the content is determined. The tier level of the content may be determined based upon the popularity of the content. In the following example, three different tiers are used. However, two different tiers corresponding to the satellite and to a terrestrial communication may also be used. In this example, tier one corresponds to pushing contents from the satellite to the user device. The content will be recorded on the network partition of the user device. Tier two corresponds to an "opted-in" contents that are downloaded from the satellite per requests or preferences of the user device. The content is recorded on the user's partition of the customer hard drive. Tier three material or content may consist of less popular contents or niche-appeal contents that appeal to a small audience. The content may be delivered by or through the communication network 132. Contents in tier three category are recorded on the user's partition of the memory device of the user device. Some content may be communicated to the user device upon request (pulled) and some may be "pushed" to the user according to the preferences of the user. In step 716, the delivery method is determined based upon the tier level of the content. In step 718, the content is packetized at the video transport processing system with SCIDs or PIDs, PMT and CRC.

In step 720, it is determined whether or not the tier level corresponds to a satellite. In this example, tier one- and tier two-level contents correspond to the satellite distribution. If satellite distribution is determined based upon the tier level, step 722 sends a message to the transport processing system 250 of FIG. 2 to start a broadcast. In step 724, mapping may be obtained from the content management system. The mapping may be broadcast with the guide data at times other than when the content is transmitted. The content distribution system 260 obtains the mapping and changes the SCIDs or PIDs from the VTPS 223 to broadcast SCIDs or PIDs. In step 725, the program map table (PMT) is removed from the header. In step 726, a new CRC is calculated. In step 727, the content with the broadcast SCID or PIDs and the CRC are broadcast through the satellite. In step 728, content is stored in the partition of the user device in response to the tier level. That is, tier level one contents may be stored on the network partition of the user device whereas tier two contents may be stored in the user's partition of the hard drive or of the user device. In step 730, the contents are utilized at the user device.

Referring back to step 720, if the content or tier level does not correspond to a satellite, step 732 is performed. In step 732, the contents are transferred to a content delivery network. In step 734, the contents are published. In step 736, the contents are communicated to the user device through the communication network 132.

In step 738, the content is stored in the partition of the user device. In this example, the non-satellite material corresponds to tier three. Tier three content is stored in the user's partition of the memory of the user device. After step 738, step 730 is again performed in which the user device utilizes the content.

Those skilled in the art can now appreciate from the foregoing description that the broad teachings of the disclosure can be implemented in a variety of forms. Therefore, while this disclosure includes particular examples, the true scope of the disclosure should not be so limited since other modifications will become apparent to the skilled practitioner upon a study of the drawings, the specification and the following claims.

What is claimed is:

1. A method comprising:

receiving a content file at a video transport processing system, from a content source;

storing a content file in a content repository;

communicating a plurality of conditional access information to a video transport processing system, from a conditional access system;

storing a relative time of arrival of each of the plurality of conditional access information at the video transport system;

wherein the relative time of each arrival are relative to the time when an initial control word or an initial access information is received at the video transport processing system;

encrypting the content file based on the plurality of conditional access information for a duration corresponding to the relative time of arrival to form an encrypted content file;

and communicating the encrypted content file to at least one user device through a broadband communication system.

2. The method as recited in claim 1 further comprising prior to storing a content file, receiving a content file from a content source.

3. The method as recited in claim 1 wherein communicating a plurality of conditional access information to a video

transport processing system comprises communicating the plurality of conditional access information in real time.

4. The method as recited in claim 1 wherein communicating a plurality of conditional access information to a video transport processing system comprises communicating the plurality of conditional access information from a schedule program associated data server.

5. The method as recited in claim 1 wherein communicating a plurality of conditional access information to a video transport processing system comprises communicating the plurality of conditional access information from a content management system.

6. The method as recited in claim 1 wherein communicating a plurality of conditional access information to a video transport processing system comprises communicating the plurality of conditional access information from a content management system through a schedule program associated data server.

7. The method as recited in claim 1 wherein storing the relative time of arrival comprises storing the relative time of arrival in a video transport processing system.

8. The method as recited in claim 1 further comprising after encrypting, storing the encrypted content file in a content repository.

9. The method as recited in claim 1 further comprising after encrypting, storing the encrypted content file.

10. The method as recited in claim 9 wherein the content file comprises a first file identifier and further comprising after encrypting, storing the encrypted content file in the content repository with a second file identifier different than the first file identifier.

11. The method as recited in claim 9 further comprising after storing the encrypted content file, communicating the encrypted content file to a user device.

12. The method as recited in claim 11 further comprising after storing the encrypted content file, communicating the encrypted content file to the user device through a satellite.

13. The method as recited in claim 11 further comprising after storing the encrypted content file, communicating the encrypted content file through a broadband connection.

14. The method as recited in claim 11 further comprising after storing the encrypted content file, communicating the encrypted content file through a wireless connection.

15. The method as recited in claim 11 wherein the user device is a satellite television set top box having a digital video recorder therein.

16. The method as recited in claim 15 wherein storing the content comprises storing the content in the digital video recorder.

17. The method as recited in claim 9 further comprising after storing the encrypted content file, communicating the encrypted content file through a terrestrial communication network.

18. The method as recited in claim 1 wherein the conditional access information comprises control words.

19. The method as recited in claim 1 wherein the conditional access information comprises electronic countermeasures.

20. A method comprising:

receiving a content file at a video transport processing system, from a content source;

storing a content file in a content repository;

communicating to a video transport processing system first conditional access information corresponding at a first time and a second conditional access information at a second time after the first time, from a conditional access system;

19

storing a relative time of arrival of each of the plurality of conditional access information at the video transport system;

wherein the relative time of each arrival are relative to the time when an initial control word or an initial access information is received at the video transport processing system;

sequentially retrieving the content file from the content repository;

sequentially encrypting the content file based on the first conditional access information for a duration corresponding to the relative time of arrival of the first conditional access information and then encrypting the content file based on the second conditional access information for a duration corresponding to the relative time of arrival of the second conditional access information;

and communicating the encrypted content file to at least one user device through a broadband communication system.

21. The method as recited in claim **20** further comprising determining the second time relative to the first time.

22. The method as recited in claim **20** wherein the first time corresponds to a start of a content file.

23. The method as recited in claim **20** wherein communicating to a video transport processing system comprises communicating to the video transport system in real time.

24. The method as recited in claim **20** wherein communicating to a video transport processing system comprises communicating to the video transport system from a schedule program associated data server.

25. The method as recited in claim **20** wherein communicating to a video transport processing system comprises communicating to the video transport system from a content management system.

26. The method as recited in claim **20** wherein communicating to a video transport processing system comprises communicating to the video transport system through a schedule program associated data server.

27. The method as recited in claim **20** further comprising storing the first time and the second time.

28. The method as recited in claim **20** further comprising storing the first time and the second time in a video transport processing system.

29. The method as recited in claim **20** further comprising after sequentially encrypting, storing the encrypted content file in a content repository.

30. The method as recited in claim **20** further comprising after sequentially encrypting, storing the encrypted content file.

31. The method as recited in claim **30** wherein the content file comprises a first file identifier and further comprising after sequentially encrypting, storing the encrypted content file in the content repository with a second file identifier different than the first file identifier.

32. The method as recited in claim **30** further comprising after storing the encrypted content file, communicating the encrypted content file to a user device.

33. The method as recited in claim **32** wherein the user device is a satellite television set top box having a digital video recorder therein.

34. The method as recited in claim **33** wherein storing the content comprises storing the content in the digital video recorder.

35. The method as recited in claim **30** further comprising after storing the encrypted content file, communicating the encrypted content file to the user device through a satellite.

20

36. The method as recited in claim **30** further comprising after storing the encrypted content file, communicating the encrypted content file through a broadband connection.

37. The method as recited in claim **30** further comprising after storing the encrypted content file, communicating the encrypted content file through a wireless connection.

38. The method as recited in claim **30** further comprising after storing the encrypted content file, communicating the encrypted content file through a terrestrial communication network.

39. The method as recited in claim **20** wherein the conditional access information comprises control words.

40. A system comprising:

- a memory for storing computer-executable instructions;
- and
- a processor configured to execute the computer-executable instructions to perform the operations including:
 - receiving a content file at a video transport processing system, from a content source;
 - storing a content file in a content repository;
 - communicating a plurality of conditional access information to a video transport processing system, from a conditional access system;
 - storing a relative time of arrival of each of the plurality of conditional access information at the video transport system;
 - wherein the relative time of each arrival are relative to the time when an initial control word or an initial access information is received at the video transport processing system;
 - encrypting the content file based on the plurality of conditional access information for a duration corresponding to the relative time of arrival to form an encrypted content file;
 - and communicating the encrypted content file to at least one user device through a broadband communication system.

41. The system as recited in claim **40** further comprising a content source communicating the content file to the content repository.

42. The system as recited in claim **40** wherein the video transport processing system receives the conditional access communicating in real time.

43. The system as recited in claim **40** further comprising a schedule program associated data server communicating the plurality of conditional access information to the video transport processing system.

44. The system as recited in claim **40** further comprising a content management system communicating the plurality of conditional access information to the video transport processing system.

45. The system as recited in claim **40** further comprising a content management system and a schedule program associated data server communicating the plurality of conditional access information to the video transport processing system.

46. The system as recited in claim **40** wherein the content repository stores the encrypted content file.

47. The system as recited in claim **46** wherein the content file comprises a first file identifier and the encrypted file comprises a second file identifier different than the first file identifier.

48. The system as recited in claim **46** further comprising a content distribution system communicating the encrypted content file to a user device.

49. The system as recited in claim **48** wherein the content distribution system communicates the encrypted content file to the user device through a satellite.

50. The system as recited in claim **48** wherein the content distribution system communicates the encrypted content file to the user device through a broadband connection.

51. The system as recited in claim **48** wherein the content distribution system communicates the encrypted content file 5 to the user device through a wireless connection.

52. The system as recited in claim **48** wherein the user device comprises a satellite television set top box having a digital video recorder therein.

53. The system as recited in claim **40** wherein the condi- 10 tional access information comprises control words.

54. The system as recited in claim **40** wherein the conditional access information comprises electronic counter measures.

* * * * *