



US009046446B1

(12) **United States Patent**
Carroll et al.

(10) **Patent No.:** **US 9,046,446 B1**
(45) **Date of Patent:** **Jun. 2, 2015**

(54) **METHOD AND APPARATUS FOR ENVIRONMENTAL PROTECTION OF DRIVE-OVER TIRE TREAD DEPTH OPTICAL SENSORS**

(71) Applicant: **Hunter Engineering Company, St. Louis, MO (US)**

(72) Inventors: **Craig A. Carroll, O'Fallon, MO (US); Michael T. Stieff, Wentzville, MO (US)**

(73) Assignee: **HUNTER ENGINEERING COMPANY, St. Louis, MO (US)**

(*) Notice: Subject to any disclaimer, the term of this patent is extended or adjusted under 35 U.S.C. 154(b) by 0 days.

(21) Appl. No.: **14/185,181**

(22) Filed: **Feb. 20, 2014**

Related U.S. Application Data

(60) Provisional application No. 61/768,194, filed on Feb. 22, 2013.

(51) **Int. Cl.**
G01L 7/00 (2006.01)
G01L 7/08 (2006.01)
G01N 21/00 (2006.01)
G01M 17/02 (2006.01)
G01B 11/22 (2006.01)

(52) **U.S. Cl.**
CPC **G01M 17/027** (2013.01); **G01B 11/22** (2013.01)

(58) **Field of Classification Search**
None
See application file for complete search history.

(56) **References Cited**

U.S. PATENT DOCUMENTS

5,101,754 A * 4/1992 Bartscher et al. 116/34 R
5,274,355 A * 12/1993 Galan 340/445

5,987,978 A 11/1999 Whitehead
6,062,072 A * 5/2000 Mock et al. 73/146.5
6,081,324 A * 6/2000 Yagita et al. 356/237.1
6,870,471 B2 * 3/2005 Bergerhoff et al. 340/447
6,944,908 B2 * 9/2005 Hoetzer et al. 15/316.1
7,235,123 B1 * 6/2007 Biegelsen 96/26
7,273,082 B2 * 9/2007 White et al. 152/417
7,518,714 B2 * 4/2009 Voeller et al. 356/155
7,575,773 B2 * 8/2009 Ishizuka et al. 427/58
7,578,180 B2 8/2009 Lionetti et al.
7,975,540 B2 7/2011 Angell
8,171,783 B2 5/2012 Tracy
8,576,060 B2 * 11/2013 Deniau et al. 340/447
8,621,919 B2 1/2014 Pingel
8,625,105 B2 1/2014 Pryce et al.
2007/0169818 A1 * 7/2007 Badstue 137/225
2014/0104426 A1 * 4/2014 Boegel et al. 348/148

FOREIGN PATENT DOCUMENTS

EP 0469948 B1 10/1995
WO 9610727 A1 4/1996
WO 9707380 A2 2/1997

* cited by examiner

Primary Examiner — Peter Macchiarolo

Assistant Examiner — Jermaine Jenkins

(74) *Attorney, Agent, or Firm* — Polster, Lieder, Woodruff & Lucchesi, L.C.

(57) **ABSTRACT**

A drive-over tire tread depth measurement system is configured with components for preventing or impeding environmental contaminants from falling through openings in a vehicle support surface or cover plate onto sensor optical windows and adjacent surfaces. The components may include active mechanisms, in the form of air discharge assemblies, movable shields, guards, wipers or deflectors, and/or passive components such as drip edges, water-accumulating textured surfaces, flow diverters, and selectively placed flanges or fixed guards which operate cooperatively to displace accumulated contaminants, debris, or liquids from the optical windows and adjacent sensor surfaces on a periodic basis.

23 Claims, 7 Drawing Sheets

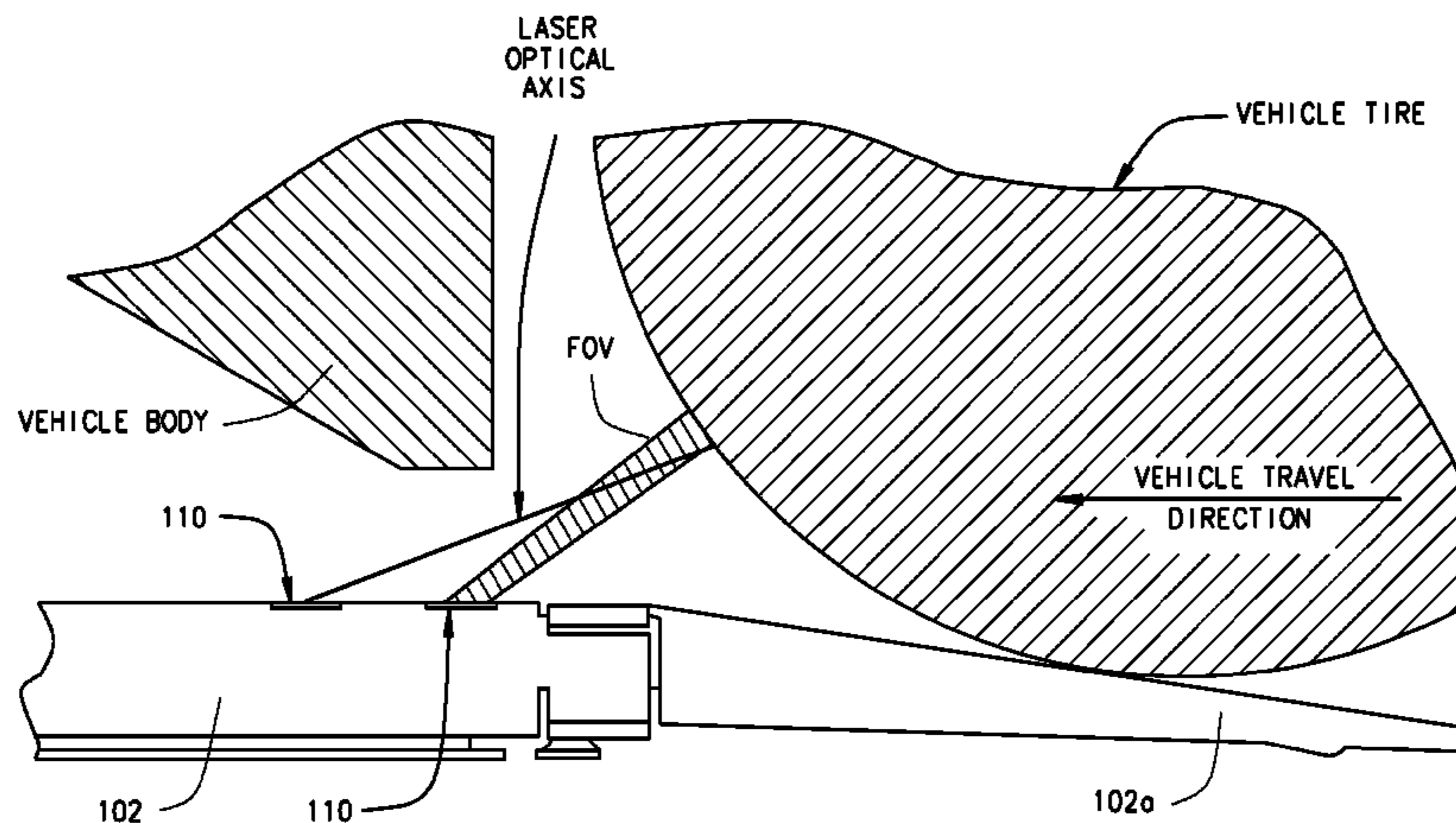

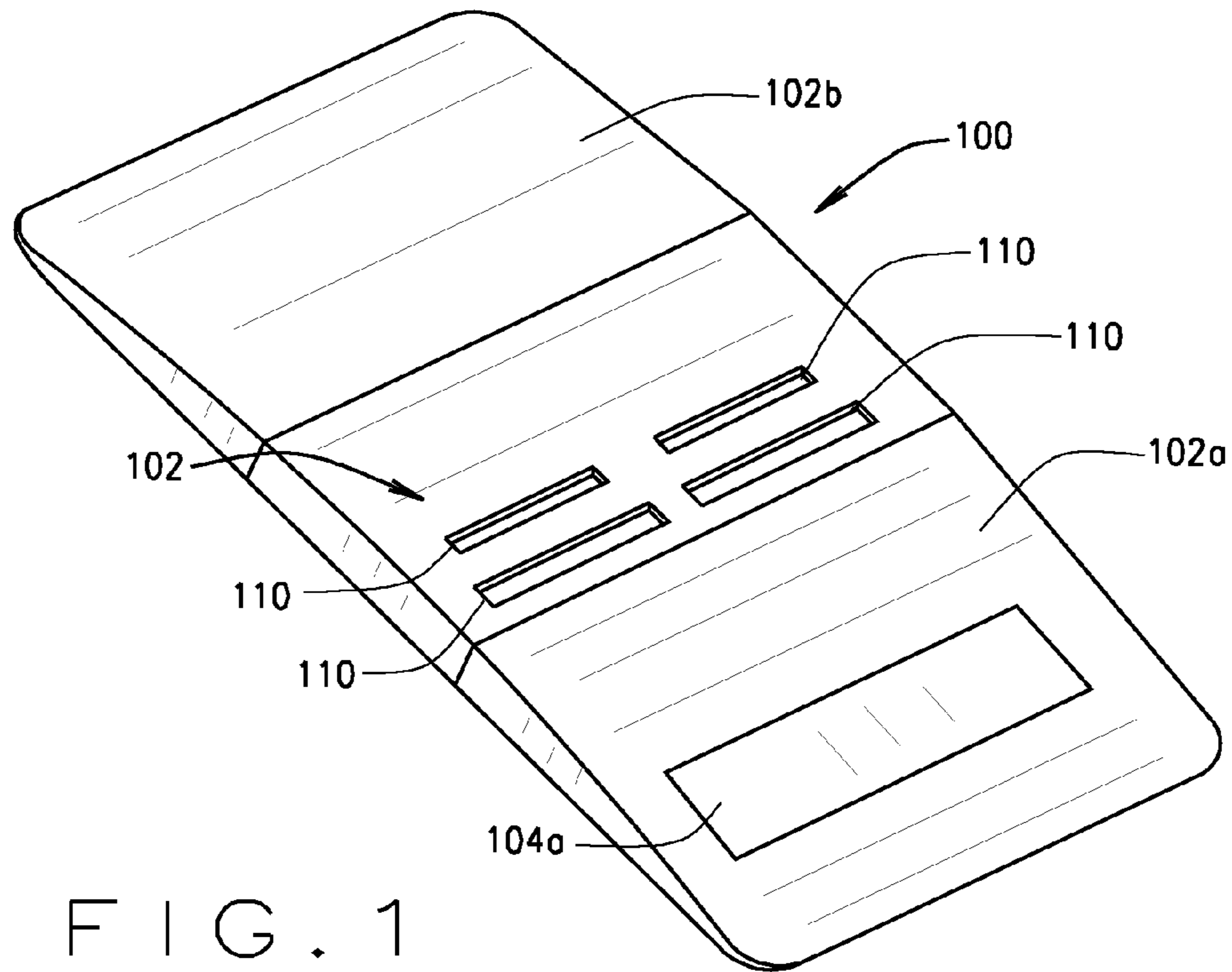

FIG. 1

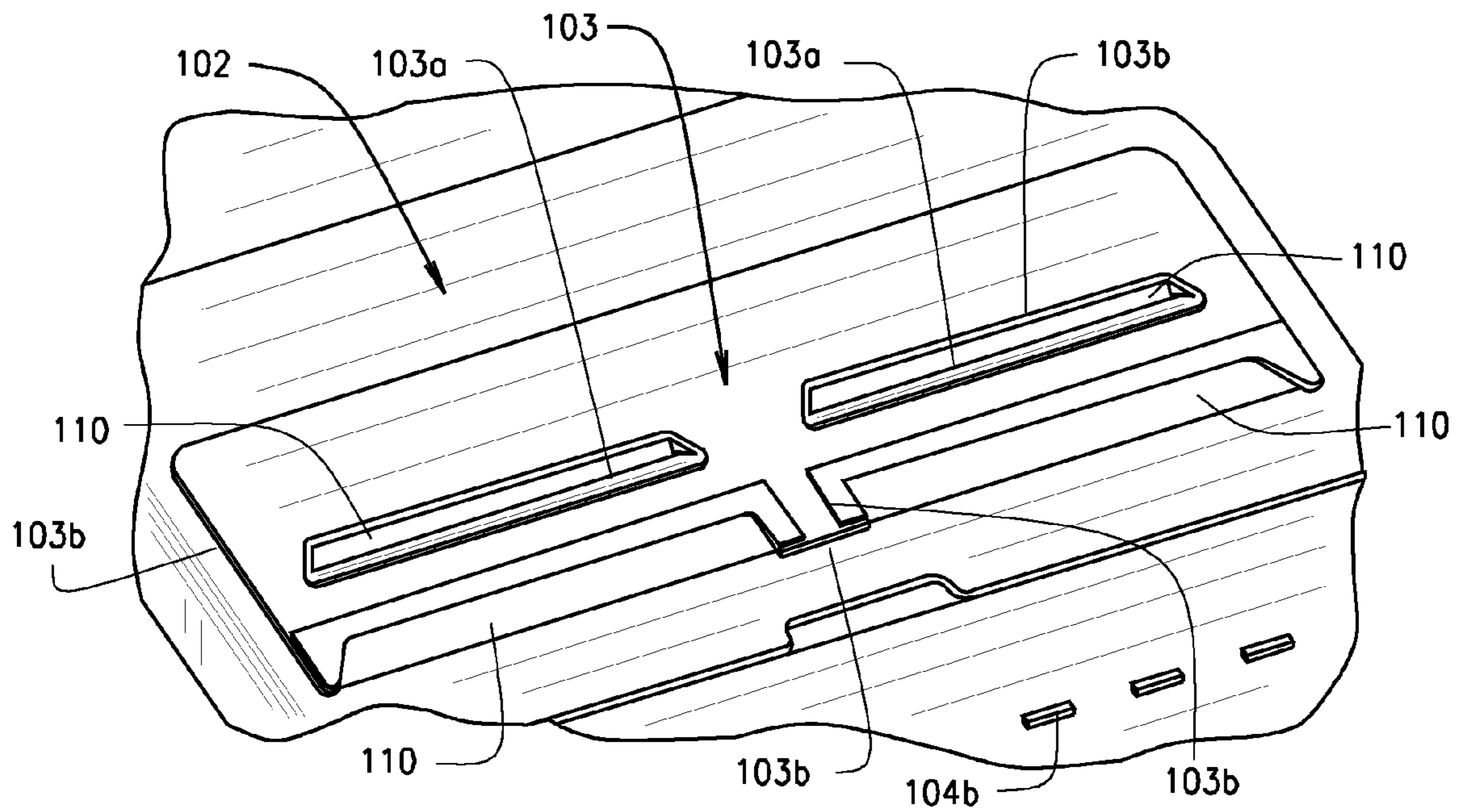

FIG. 2

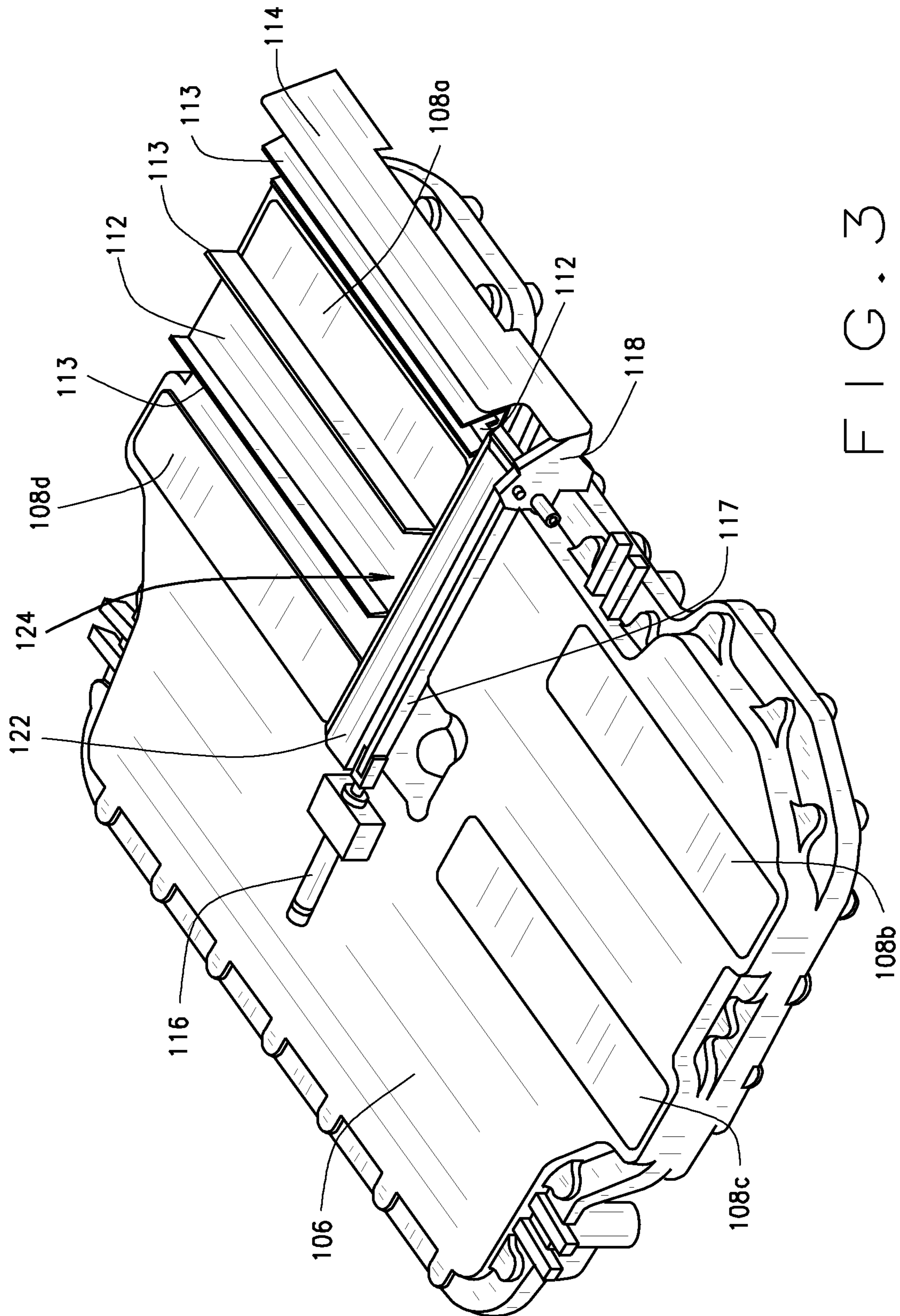

FIG. 3

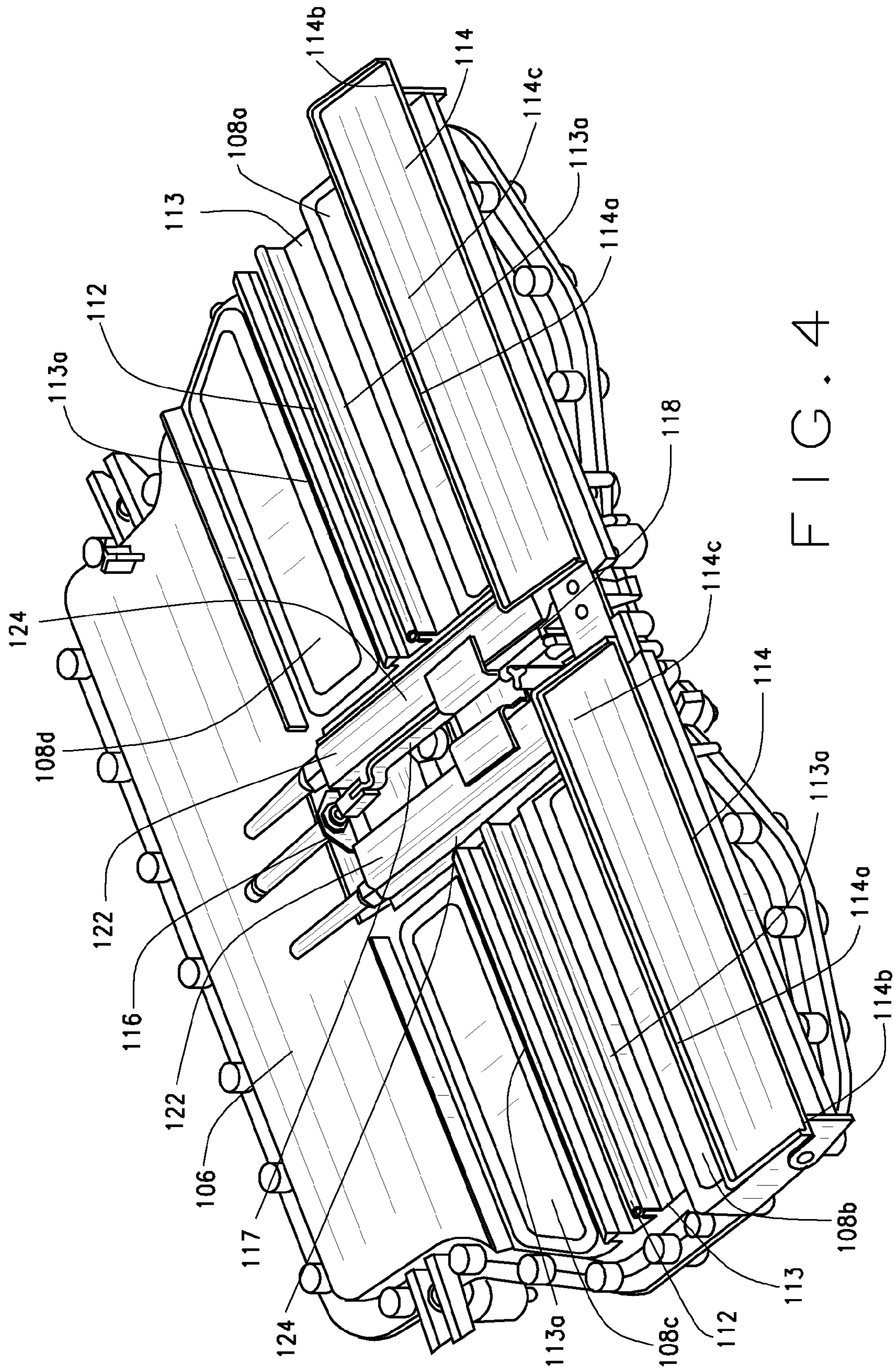

FIG. 4

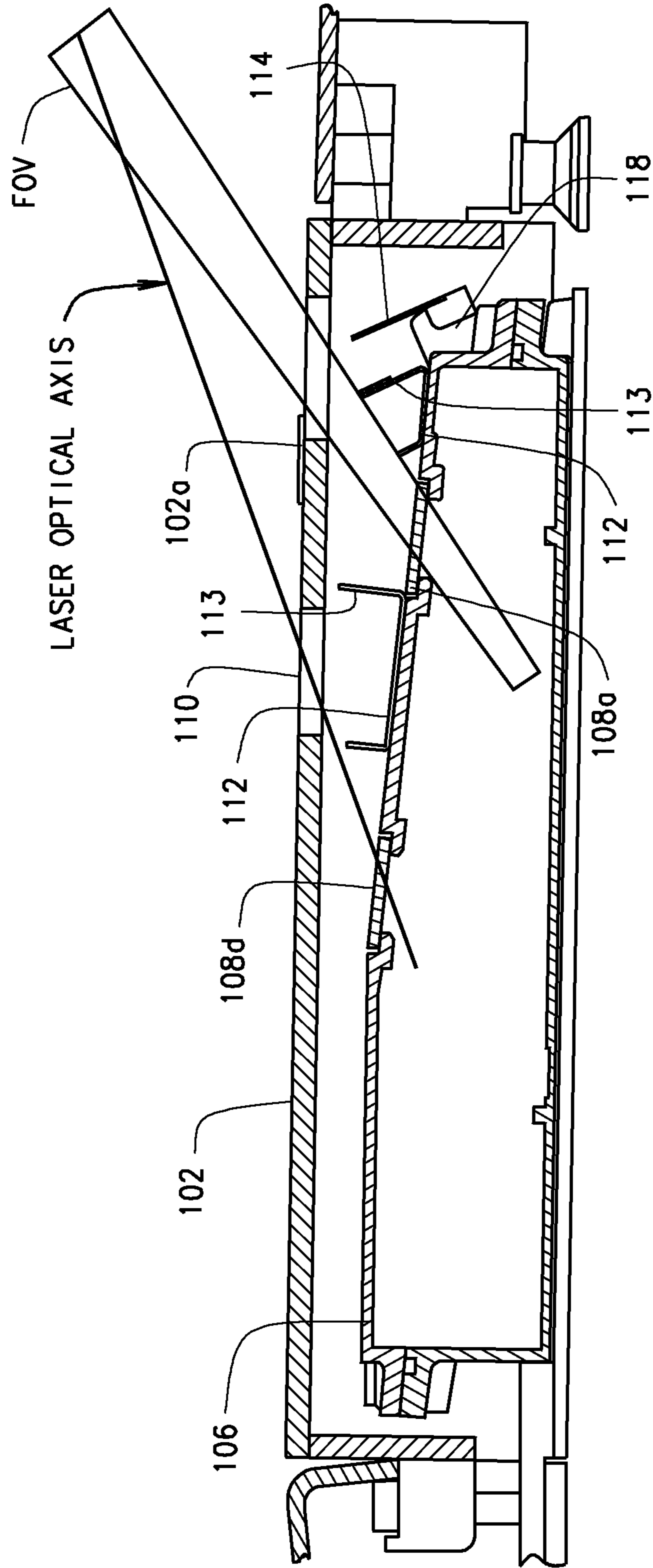

FIG. 5

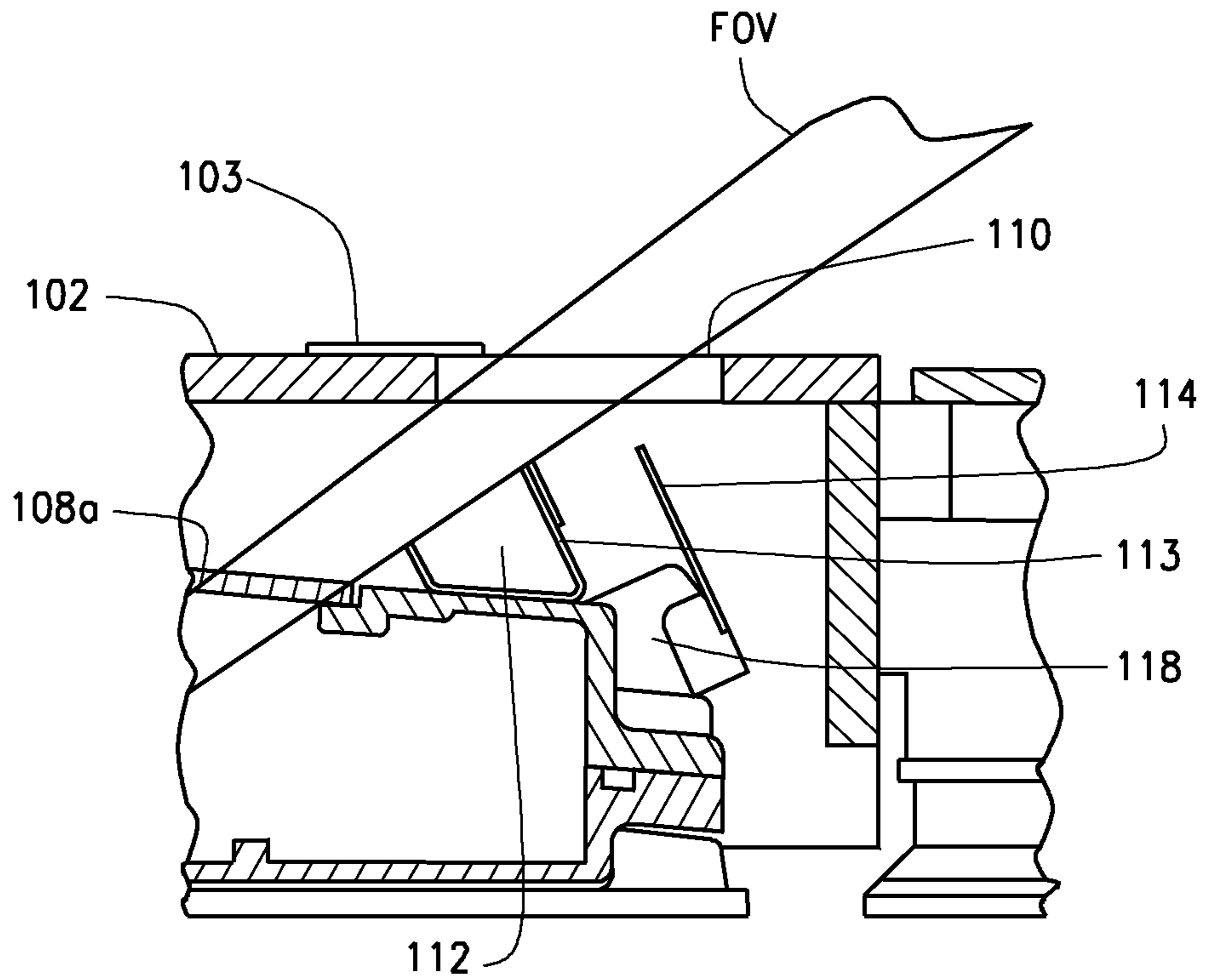

FIG. 6

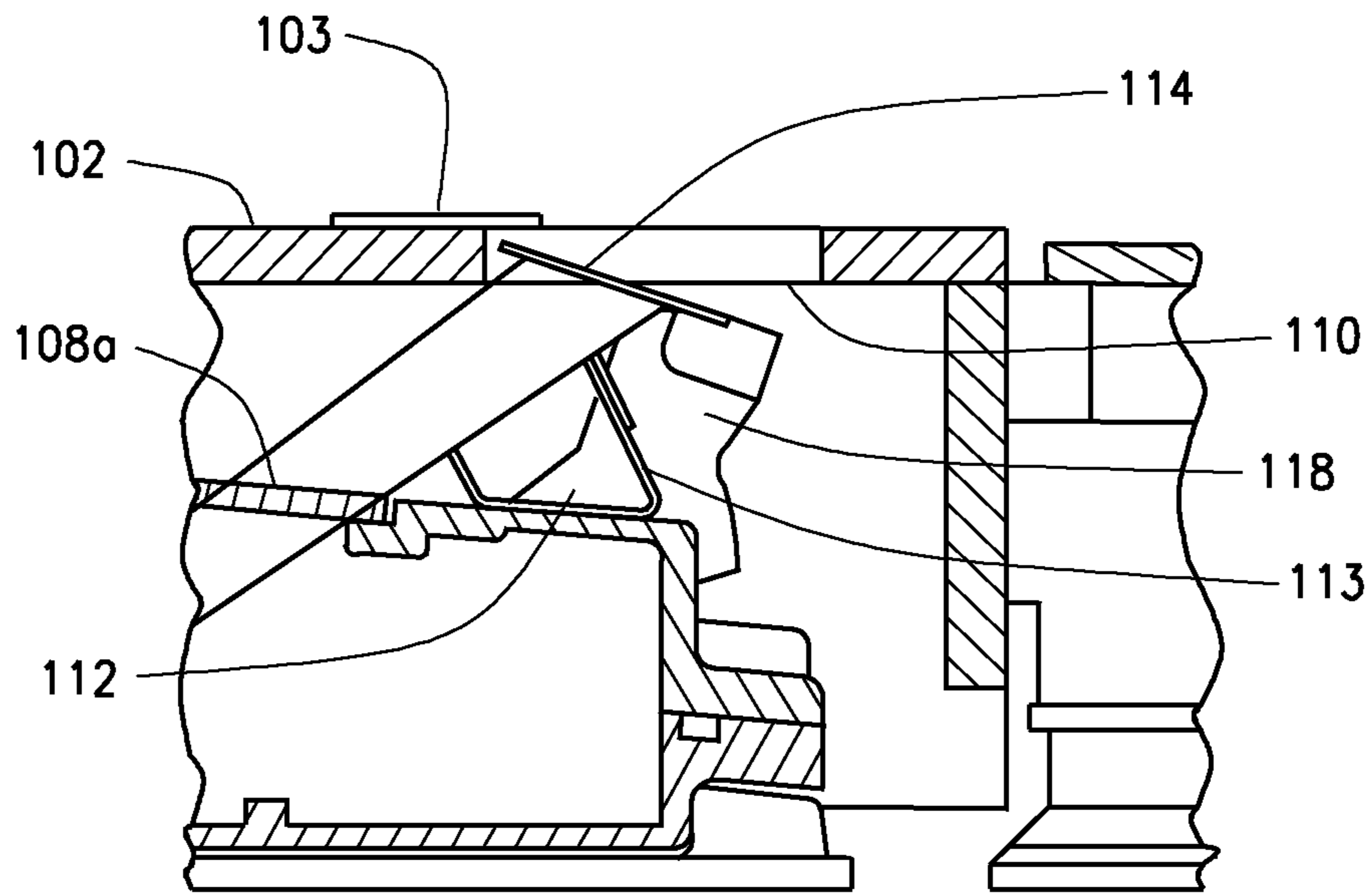

FIG. 7

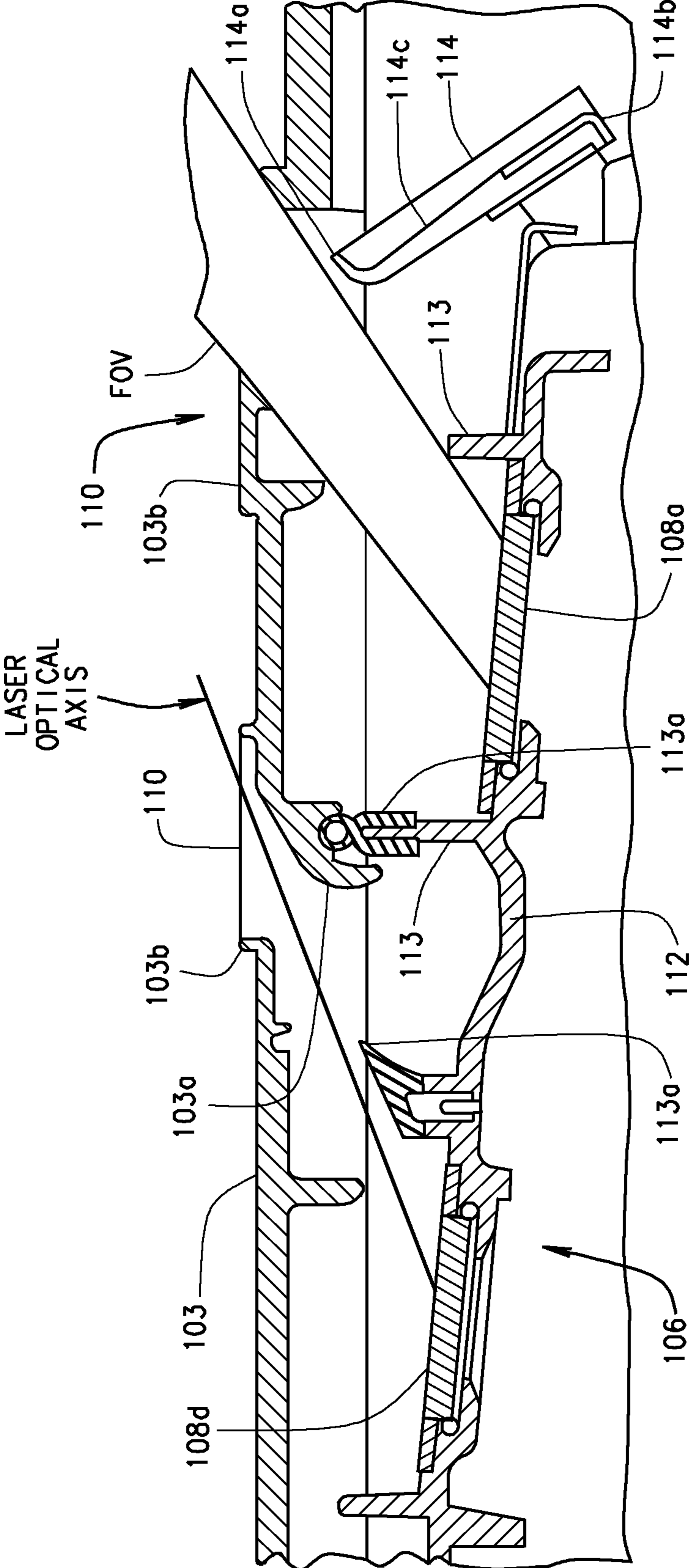

FIG. 8

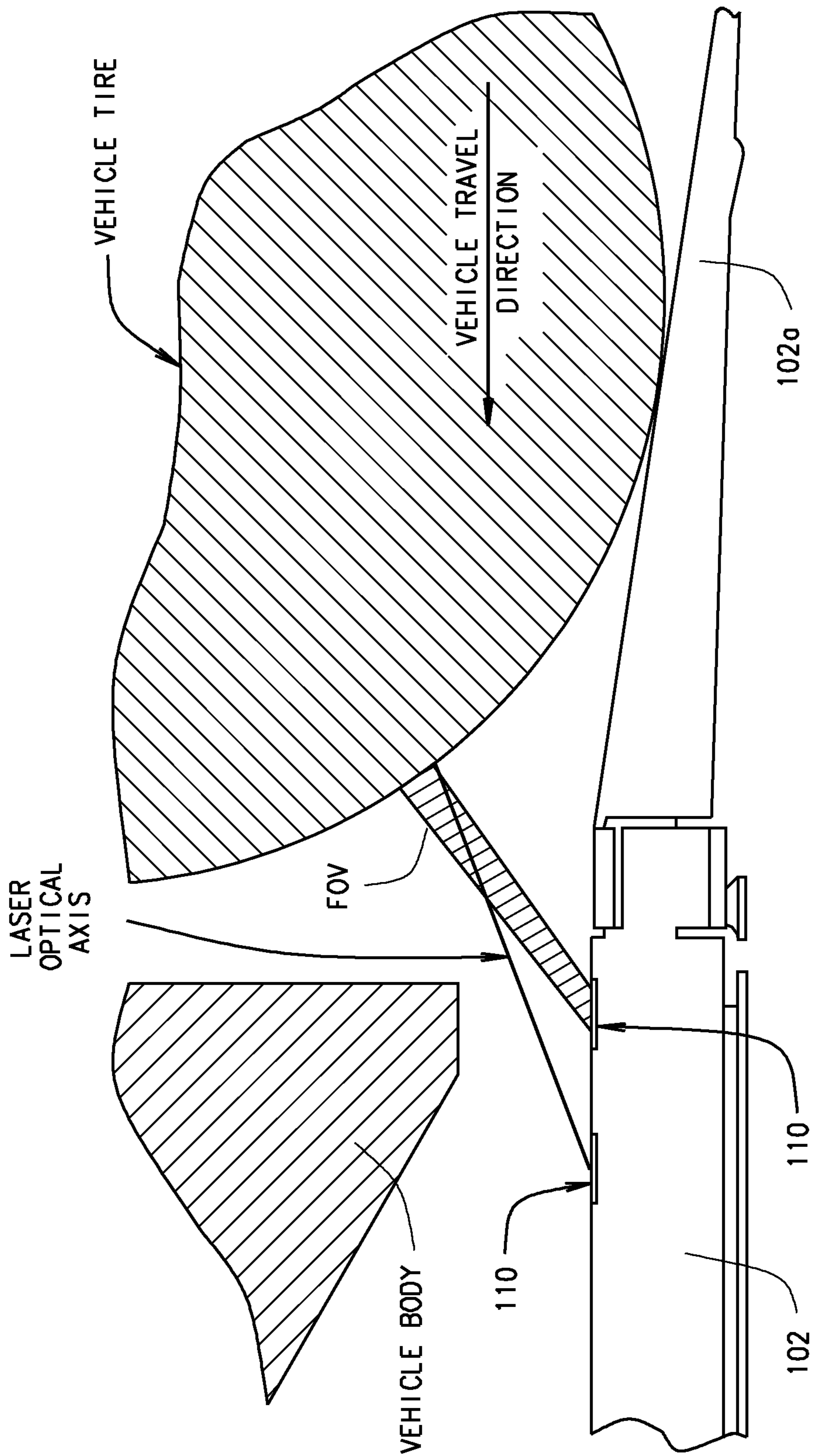

FIG. 9

1

**METHOD AND APPARATUS FOR
ENVIRONMENTAL PROTECTION OF
DRIVE-OVER TIRE TREAD DEPTH OPTICAL
SENSORS**

CROSS-REFERENCE TO RELATED
APPLICATIONS

The present application is related to, and claims priority from, U.S. Provisional Patent Application Ser. No. 61/768, 194 filed on Feb. 22, 2013, and which is herein incorporated by reference.

STATEMENT REGARDING FEDERALLY
SPONSORED RESEARCH

Not Applicable.

BACKGROUND OF THE INVENTION

The present invention is related to optical sensors disposed within a surface over which vehicles are driven, which are exposed to environmental conditions, and in particular, to methods and apparatus for protecting optical surfaces from environmental debris and for the automatic clearing of accumulated environmental debris from the optical surfaces.

The use of optical sensors for the acquisition of data associated with motor vehicle are becoming prevalent in the automotive service industry and for use in monitoring vehicular traffic. For some applications, such as the acquisition of data associated with vehicle wheels, and in particular, tire conditions, the optical sensors are disposed in, or below, a supporting surface over which the vehicle wheels roll, such as a roadway surface, vehicle service bay floor, or vehicle service/inspection support structure. Embedded or drive-over optical sensors may include components for projecting illuminating energy towards and onto the surfaces of a passing vehicle, as well as receiving components for capturing reflected energy from the passing vehicle. For example, some tire tread depth measurement systems consist of a laser emitter configured to project a laser light onto or across the surface of a tire passing over the optical sensor, and a cooperatively configured imaging sensor disposed in proximity for acquiring images of the projected laser light reflected from the passing tire.

Optical sensors disposed in a drive-over configuration, where a vehicle is driven or rolled over the sensor, are typically contained within a sealed housing having one or more panels of optically transparent material such as glass or plastic through which illuminating light is projected and/or reflected light is observed. While such sealed housings function well to provide protection against water or debris intrusion and damage to the sensors, performance of the sensors can be degraded to the point of inoperability by the accumulation of environmental contaminants, such as dust, dirt, rocks, salt, and water on the optically transparent panels. Such accumulations of environmental contaminants can occlude the optical lines of sight for both emitter components and imaging components.

Accordingly, it would be advantageous to provide optical sensors, disposed in a drive-over configuration, with components for preventing or impeding environmental contaminants from falling onto the panels of optically transparent material and adjacent sensor surfaces. The mechanisms may be either active mechanisms, in the form of movable shields, guards, or deflectors, or passive components such as drip edges, water-accumulating textured surfaces, flow diverters, or selectively placed flanges or fixed guards.

2

It would be further advantageous to provide optical sensors, disposed in a drive-over configuration, with a mechanism for selectively shielding the panels of optically transparent material during periods of inactivity. In one embodiment, the shielding mechanism is recessed below the surface over which a vehicle is driven in order to isolate the shielding mechanism from direct contact with the vehicle wheels.

It would be further advantageous to provide optical sensors, disposed in a drive-over configuration, with a mechanism for cleaning and/or clearing of environmental contaminants from the exposed surface of the panels of optically transparent material and adjacent surfaces.

BRIEF SUMMARY OF THE INVENTION

Briefly stated, the present disclosure sets forth a mechanism for selectively shuttering openings in a vehicle supporting surface through which underlying optical sensors emit or receive light energy during acquisition of data associated with vehicle. The mechanism includes at least one shutter panel which is selectively movable between an open position, in which the opening is unobstructed, and a closed position in which the opening is at least partially blocked by the shutter panel to prevent or deflect environmental contaminants such as dust, dirt, rocks, salt, or water from passing downward through the openings and onto the surface of the underlying optical sensors. When in the closed position, the shutter panel remains recessed below the vehicle supporting surface.

In an alternate embodiment, optical sensors disposed below a vehicle supporting surface in a drive-over configuration are protected against environmental contaminants by passive components such as drip edges, water-accumulating textured surfaces, flow diverters, selectively placed flanges and/or fixed guards which are disposed on various surfaces below the vehicle supporting surface, in proximity to openings there in through which the optical sensors transmit or receive light.

In a further embodiment, optical sensors disposed in a drive-over configuration are provided with a mechanism for cleaning and/or clearing of environmental contaminants from surfaces disposed below the openings in the vehicle supporting surface. The mechanism may be operated periodically on a selected cycle, upon each use by activation of a drive-over trigger, or on an as-needed basis, controlled either by the operator or a feedback system evaluating the integrity of emitted and/or reflected light at the optical sensor. To clean and/or clear the environmental contaminants from the surfaces, the mechanism selectively discharges a flow of high-pressure air or an air/fluid mixture across the surfaces to be cleared or cleaned, to transport accumulated debris off the surfaces and into an adjacent discharge region.

The foregoing features, and advantages set forth in the present disclosure as well as presently preferred embodiments will become more apparent from the reading of the following description in connection with the accompanying drawings.

BRIEF DESCRIPTION OF THE SEVERAL
VIEWS OF THE DRAWINGS

In the accompanying drawings which form part of the specification,

FIG. 1 is a perspective illustration of an embodiment of a drive-over tire tread depth optical sensor system

3

FIG. 2 is a perspective illustration of the vehicle support surface/cover plate of an embodiment of the drive-over tire tread depth optical sensor system

FIG. 3 is a perspective illustration of an embodiment of the drive-over tire tread depth optical sensor system, with the vehicle support surface/cover plate removed, showing the sensor housing with environmental protection features installed adjacent one pair of optical windows only for comparison

FIG. 4 is a perspective illustration of another embodiment of the drive-over tire tread depth optical sensor system, showing a sensor housing with a complete set of environmental protection features installed

FIG. 5 is a side sectional view of an embodiment of the drive-over tire tread depth optical sensor system, illustrating the optical field of view and laser projection pathway through the openings in the vehicle support surface/cover plate;

FIG. 6 is a close-up view of a portion of FIG. 5, illustrating placement of drip guards, gutters, and a mechanical shutter in the open position;

FIG. 7 is a close-up section view similar to FIG. 6, illustrating the placement of drip guards, gutters, and a mechanical shutter in the closed position;

FIG. 8 is a close-up side section view of an embodiment of the drive-over tire tread depth optical sensor system, illustrating cover plate features, gutters, deflecting lips and baffles; and

FIG. 9 is a representation of the angular relationships between a surface of an approaching vehicle wheel, a vehicle air dam, the laser projection pathway, and the optical field of view from the drive-over tread depth optical sensor system of the present disclosure.

Corresponding reference numerals indicate corresponding parts throughout the several figures of the drawings. It is to be understood that the drawings are for illustrating the concepts set forth in the present disclosure and are not to scale.

Before any embodiments of the invention are explained in detail, it is to be understood that the invention is not limited in its application to the details of construction and the arrangement of components set forth in the following description or illustrated in the drawings.

DETAILED DESCRIPTION

The following detailed description illustrates the invention by way of example and not by way of limitation. The description enables one skilled in the art to make and use the present disclosure, and describes several embodiments, adaptations, variations, alternatives, and uses of the present disclosure, including what is presently believed to be the best mode of carrying out the present disclosure.

Turning to the Figures, and to FIGS. 1 and 2 initially, an exemplary drive-over tire tread depth optical sensor system is shown generally at 100. The sensor system consists of a vehicle support surface 102 for supporting the wheels of a vehicle being driven over the sensor system. A cover plate or deflector 103 may be disposed on a portion of the vehicle support surface 102, and configured to divert water accumulating on the vehicle support surface 102 from entering the sensor system 100. Suitable ramps 102a, 102b may be provided if the sensor system 100 is disposed on a floor surface. Alternatively, the sensor system 100 may be disposed in a recessed portion of a floor or roadway surface, with the vehicle support surface 102 substantially coplanar with the adjacent floor or roadway surfaces. Suitable trigger mechanisms 104a, 104b for activating the sensor system 100 may be incorporated into the vehicle support surface 102, ramps

4

102a, 102b, or adjacent floor or roadway surfaces. The entire vehicle support surface 102, or at least a portion thereof, may be configured to be opened or removed, allowing access to the underlying components of the sensor system for manual cleaning, repair, or replacement as necessary from time to time.

As seen in FIGS. 3 and 4, the various electronic and optical components which comprise the sensor system 100 are disposed within an environmentally sealed sensor housing 106, positioned below the vehicle support surface 102 and/or cover plate 103. The sensor housing 106 may be mounted directly on the underlying base structure, or may be mounted in a configuration which is biased against an underside surface of the vehicle support surface 102 and/or cover plate 103 to maintain a predetermined position and orientation relative to the vehicle support surface 102 and/or cover plate 103 which may undergo deflection under load from a passing vehicle.

Optical components (not shown) disposed within the sealed sensor housing 106 are positioned and oriented to transmit and/or receive light along associated fields of view through one or more optical windows 108 which are disposed in the upper surface of the sealed housing 106. In the embodiment shown in the Figures, a total of four optical windows 108a-108d are shown in the sensor housing 106, arranged in 2x2 grid configuration. With a longitudinal axis aligned in the normal direction of vehicle travel over the sensor system 100, the longitudinally forward optical windows 108a, 108b (those over which the vehicle will pass first in the normal direction of travel) in each longitudinally aligned pair of optical windows is associated with an optical imaging sensor (not shown) for acquiring images from an associated field of view oriented towards the approaching vehicle. The longitudinally rearward optical windows 108c, 108d in each longitudinally aligned pair of optical windows is associated with a laser emitter system (not shown) for projecting laser illumination along an optical axis towards the tire tread surface of a vehicle passing over the vehicle support surface 102 and/or cover plate 103. The laser emitter system is aligned to illuminate the tire tread surface of an approaching vehicle within the field of view of the associated optical imaging sensor.

As best seen in FIGS. 5 and 9, the fields of view and optical axis associated with each pair of longitudinally aligned optical windows 108 are aligned at acute angles relative to the vehicle support surface 102 or cover plate 103, and pass through suitably sized openings 110 in the vehicle support surface 102 or cover plate 103. The acute angles are selected to enable the laser optical axis to intersect the surface of an approaching vehicle tire within a region on the tire surface which falls within the optical imaging sensor field of view, before the vehicle tire is directly over the optical windows 108a-d, and which is at a sufficient angle to avoid obstruction from adjacent vehicle body components, such as an air dam or mud flaps. Those of ordinary skill will recognized that the number and arrangement of the optical windows 108 may vary depending upon the particular configuration of the sensor system 100.

In the embodiment illustrated in FIGS. 1 and 2, it will be noted that a driver-over trigger mechanism 104a or 104b is disposed to activate the sensor assembly 100 as a vehicle wheel approaches the openings 110, and that the laser optical axis and the optical imaging sensor field of view are oriented to intersect a leading edge of the tire tread surface as the tire rotates towards the openings 110 when the vehicle is driven in the forward direction. With this configuration, an increasingly larger portion of the optical sensor field of view is occupied by the tire tread surface as the vehicle moves forward, increasing the shielding of the optical imaging sensor

5

from external light sources, such as the sun, which could result in glare or noise in images acquired by the optical imaging sensor. An additional benefit of acquiring images from the tire tread surface as the vehicle travels in the forward direction towards the sensor windows **108a**, **108b** is that there is a reduced chance for either the laser optical axis and/or the imaging sensor field of view to be obstructed by a vehicle body component. Typically, lower body panels and/or mud flaps disposed on the rearward side of vehicle wheels will reduce the amount of the tire surface visible to the optical imaging sensor field of view if a vehicle approaches the sensor windows **108a**, **108b** in a reverse direction.

The acute angles of the laser optical axis and the optical imaging sensor field of view relative to the vehicle support surface **102** or cover plate **103** permit the optical windows **108** in the sensor housing **106** to be longitudinally displaced relative to the corresponding openings **110** in the vehicle support surface **102** or cover plate **103**, as best seen in FIG. 5. As such, environmental contaminants or debris falling directly downward into the unobstructed openings **110** in the vehicle support surface **102** or cover plate **103** generally will not land on the optical windows **108**, but will accumulate on the upper surface of the sensor housing **106** in adjacent proximity there to. Absent any preventative measures, the accumulated environmental contaminants may flow or migrate onto the exposed upper surfaces of the optical windows **108**, degrading system performance and/or occluding either the laser optical axis or optical imaging sensor field of view.

Turning to FIGS. 3 and 4, a variety of features and preventative measures are employed in association with the sensor housing **106**, vehicle support surface **102**, and the cover plate **103** for protection of the optical surfaces from an accumulation of environmental contaminants and debris. It will be understood that while the present disclosure illustrates specific protective features, sensors systems **100** may incorporate different protective features described herein, as well as different numbers and combinations of the described protective features as necessitated by the sensor system configuration and operating conditions without departing from the scope of the present disclosure.

Environmental contaminants and debris falling directly through the openings **110** in the vehicle support surface **102** or cover plate **103** may be captured within one or more gutters **112** disposed on the upper surface of the sensor housing **106** between the optical window pairs (**108a**, **108d**) and (**108b**, **108c**), in vertical alignment with the openings **110**. Preferably, each gutter **112** extends parallel to the optical windows **108**, and includes raised sidewalls **113** which are continuous along each longitudinal edge. As best seen in FIGS. 5 and 8, one or more of the raised sidewalls **113** of each gutter **112** have a maximum height and/or optional contoured upper edge **113a** formed into a baffle or deflecting lip, which is limited by the laser optical axis and/or optical imaging sensor field of view, ensuring an unobstructed line of sight for the laser emitters or optical imaging sensors between the optical windows **108** and the associated vehicle support surface or cover plate openings **110**. Environmental contaminants or debris deposited into the gutters **112** are prevented from migrating or flowing onto the optical windows **108** by the sidewalls **113**, and are directed in a generally lateral direction for discharge off the side edges of the sensor housing **106**.

When the sensor system **100** is not acquiring images or in use, some or all of the openings **110** in the vehicle support surface **102** or cover plate **103** may be fully or partially closed by actuated shutters **114**. As best seen in FIGS. 3, 4, 6, and 7, an actuated shutter **114** associated with at least one of the openings **110** may be mounted to the sensor housing **106**,

6

together with an associated actuation mechanism. The actuation mechanism may include a shutter actuator **116** linked by a mechanical coupling **117** to a shutter actuation cam **118** for articulating movement of the actuated shutter **114** between an open position (shown in FIGS. 3, 5, 6, 8) and a closed position (shown in FIGS. 4, 7) which at least partially closes an opening **110** in the vehicle support surface **102** or cover plate **103**. The actuation mechanism as shown in FIGS. 3 and 4 is pneumatically operated, suitably coupled to a remote source of pressurized air. Those of ordinary skill in the art will recognize that a wide variety of actuation mechanisms may be utilized, including mechanical, electrical, and hydraulic systems. Similarly, while FIGS. 3-7 illustrate the use of the shutter actuating cam **118** coupled to the mechanical coupling for articulating the movement of each shutter **114** between an open position and a closed position, any of a variety of suitable mechanical mechanisms may be utilized, including, but not limited to, hinges, levers, and pivots.

As best seen in FIGS. 6 and 7, it is preferable that the shutter **114** be disposed below the upper surface of the vehicle support surface **102** or cover plate **103** in both the open and closed positions, for protection against damage in both positions, and to avoid interference with an laser optical axis or the optical imaging sensor field of view when in the open position. The shutter **114** may be composed of a lighter gauge material than the vehicle support surface **102** or cover plate **103**, having sufficient durability for exposure to environmental debris and contaminants. As shown in FIG. 7, when in a closed configuration, the shutter **114** need not fully seal or close an associated opening **110**, but rather, may act as a deflecting surface with appropriate lips **114a**, edges **114b**, and recessed regions **114c** (as shown in FIGS. 4 and 8) to direct incoming environmental contaminants and debris which fall through the opening **110** away from sensitive regions on the underlying surfaces of the sensor housing **106**. Preferably, the shutter **114** has dimensions which are larger than the opening **110** with which it is associated, such that environmental contaminants or debris passing through the opening **110** may not fall past the lips **114a** of the shutter **114** when the shutter is in the closed position.

For some applications, the cover plate **103** may optionally be mounted to the vehicle support surface **102** in proximity to one or more openings **110**, in such a manner as to extend partially over, and into, the openings without interference with an optical axis or field of view passing there through. The cover plate **103** functions in cooperation with the shutter **114** (if present) to divert incoming environmental contaminants or debris onto the surface of the shutter. As seen in FIGS. 2 and 8, a rolled or rounded edge or lip **103a** of the cover plate **103** may extend inward towards the sensor housing, and serve to collect, control, or divert liquid contaminants (i.e., water, oil, salt solutions, etc.) to thereby form droplets or fluid flows at controlled locations relative to the sensor housing **106** below by taking advantage of liquid surface tension, adhesion characteristics, and air flow. Similarly, raised edges **103b** of the cover plate **103** above the surface of the vehicle support surface **102** further serve to divert fluid flow of liquids accumulating on the vehicle support surface **102** away from the openings **110**.

Incoming liquid contaminants may be further controlled by application of suitable surface coatings on the sensor housing **106** and optical windows **110**, as well as surface textures, grooves, lips and drip edges formed on the various surfaces, such as the underside surface of the cover plate **103** to encourage droplet formation over the gutters **112**, and to divert liquid flows away from the optical windows **108**. Exemplary coatings which may be applied to any of the exposed surfaces on

the sensor housing, such as the optical windows **108** or gutters **112**, include optically transparent nano-coatings, hydrophobic coatings, and other surface coatings which resist adhesion and/or encourage beading of liquid contaminants.

Environmental contaminants, debris, and liquids which pass through the openings **110** in the vehicle support surface **102** and/or cover plate **103**, and which accumulate or collect on the upper surfaces of the sensor housing **106**, including the optical windows **108** and within the gutters **112** must be periodically removed. Manual removal of accumulated material requires removal of the vehicle support surface **102** to access the underlying surface of the sensor housing **106**, and is not always convenient or practical. In an embodiment of the present invention, an automated system for the clearing of accumulated debris from the sensor housing surfaces is provided. The cleaning system, best seen in FIGS. **3** and **4**, consists of one or more air knife or air blade assemblies **122**, each of which are configured with one or more air nozzles **124** to direct a flow or blast of pressurized air across the surfaces of the sensor housing. As best seen in FIG. **3**, a pair of air knife assemblies **122** may be disposed along the longitudinal midline of the sensor housing **106**, laterally between adjacent optical windows **108** and gutters **112**. Each air knife assembly **122** includes air nozzles or discharge openings **124** which are oriented to direct a flow or blast of pressurized air laterally outward towards the lateral edges of the sensor housing **106**. For example, as seen in FIG. **4**, at least one air nozzle **124** is associated with each optical window **108** and each gutter **112**.

During operation, pressurized air is periodically delivered to the air knife assemblies **122** and discharged through the air nozzles **124**. The discharged flow or blast of pressurized air displaces accumulated contaminants, debris, or liquids from the surface of the sensor housing **106**, optical windows **108**, and/or gutters **112** in a laterally outward direction, off the lateral edges of the sensor housing **106** and into a surrounding discharge area. While shown in FIGS. **3** and **4** in a configuration which enables the lateral discharge of accumulated contaminants, debris, and liquids, those of ordinary skill will recognize that the air knife assemblies **122** and air nozzles **124** may be configured to direct the flow or blasts of pressurized air in other directions relative to the surface of the sensor housing **106** as necessitated by the configuration of the optical windows **108**, gutters **112**, and other components located in proximity thereto, without departing from the scope of the present invention.

In an alternate embodiment, the air knife assemblies **122** are either replaced by, or supplemented with, wiper mechanisms (not shown) configured to sweep one or more wiper blades across the various surfaces to displace any accumulated contaminants, debris or liquids from the surface of the sensor housing **106**, optical windows **108**, and/or gutters **112**. Preferably, the wiper mechanisms are configured to sweep the material in a laterally outward direction, off the lateral edges of the sensor housing **106** and into a surrounding discharge area.

For some applications it may be beneficial to apply a spray of cleaning solution to the optical windows **108** prior to, or in conjunction with, the discharge of pressurized air from the associated air nozzles **124** or the sweeping action of a wiper mechanism. A suitable cleaning solution delivery system (not shown) may be disposed in operative proximity to the optical windows **108**, or may be incorporated into the air knife assemblies **122**. Alternatively, a cleaning solution may be supplied directly to the air knife assemblies and delivered to the optical windows **108** directly through the air nozzles **124** with the flow or blasts of pressurized air.

Control of the active mechanisms for protection against environmental contaminate and debris ingress, as well as the periodic clearing of accumulated material may be manual or automatic. Preferably, operation of the shutters **114** is controlled automatically by a suitably configured processing system (not shown), such that the shutters **114** remain in a closed position as a default, and are opened only when necessary to enable the acquisition of tire tread images by the optical imaging sensors, such as when a drive-over trigger mechanism **104** is activated by a vehicle approaching the sensor assembly **100**.

Operation of the air knife assemblies **122** is similarly handled by a suitably configured processing system (not shown). The processing system may be programmed with software instructions to activate the air knife assemblies **122** upon each activation of the drive-over trigger mechanism **104**, on a fixed cyclical basis such as after set number of tire tread images are acquired, on a fixed time schedule such as after every hour of operation, or on a variable basis by monitoring the quality of acquired images to identify the presence of accumulating debris or contaminants on the optical windows **108**.

While the present disclosure and accompanying figures are seen to illustrate a drive-over tire tread depth sensor system **100** which incorporates multiple environmental protection features, including mechanical shutters **114**, gutters **112**, and air knife assemblies **122**, those of ordinary skill in the art will recognize that other combinations of environmental protection features may be utilized without departing from the scope of the present disclosure, depending upon the particular configuration and/or operating environment in which a drive-over optical sensor system is to be utilized.

As various changes could be made in the above constructions without departing from the scope of the disclosure, it is intended that all matter contained in the above description or shown in the accompanying drawings shall be interpreted as illustrative and not in a limiting sense.

The invention claimed is:

1. A drive-over optical tire tread depth sensor system, comprising, an optical component having an illuminating laser optical axis and an optical imaging sensor field of view; a vehicle support surface in spaced proximity to said optical component; and an air discharge system disposed in proximity to said optical axis or field of view, said air discharge system including at least one air discharge opening oriented to direct pressurized air to displace environmental contaminants, debris or liquids accumulated between said vehicle support surface and said optical component from said optical axis or field of view.
2. The system of claim **1** wherein further including a control system configured with software instructions to regulate operation of said air discharge system to selectively deliver said pressurized air to said at least one air discharge opening.
3. The system of claim **1** further including a sensor housing with at least one optical window through which said optical axis or field of view is passed; and wherein said air discharge opening is oriented to direct said pressurized air to displace said accumulated environmental contaminants, debris, or liquids away from said at least one optical window.
4. The system of claim **1** wherein said vehicle support surface includes at least opening in alignment with said optical axis or field of view; a shutter assembly having a shutter operable between a closed position at least partially occluding said at least one opening in said vehicle support surface, and an open

9

position in which said shutter is displaced from said optical axis or field of view in alignment with said associated opening.

5 **5.** The system of claim **4** wherein said shutter assembly includes an actuator configured to actuate said shutter between said closed position and said open position; and

further including a control system configured with software instructions to regulate operation of said actuator by coordinating actuation with operation of said associated optical component.

6. The system of claim **4** further including a drive-over trigger mechanism configured to generate a signal associated with the approach of a vehicle towards the at least one opening in the vehicle support surface;

wherein said shutter assembly includes an actuator configured to actuate said shutter between said closed position and said open position; and

wherein operation of said actuator is coordinated with said signal generated by said drive-over trigger mechanism.

7. The system of claim **4** wherein said shutter incorporates one or more surface features to deflect and/or direct incoming contaminates, said one or more surface features selected from a set of surface features including raised lips, channels, ridges, and recessed regions.

8. The system of claim **1** wherein said vehicle support surface includes at least one opening in alignment with said optical axis or field of view;

at least one gutter located vertically below said at least one opening; and

wherein said gutter defines a channel for diverting said environmental contaminates, debris, or liquids passing through said at least one opening away from said optical axis or field of view.

9. The system of claim **8** wherein said channel has at least one open end for discharge of said environmental debris, contaminates, and liquids away from said optical axis or field of view.

10. The system of claim **1** wherein said vehicle support surface includes at least one opening in alignment with said optical axis or field of view; and

at least one fluid flow diverting feature on said vehicle support surface or cover plate in proximity to said at least one opening, said fluid flow diverting feature selected from a set of fluid flow diverting features including a deflecting lip, surface channels, surface textures, and surface features configured to divert, accumulate, or entrap fluids for discharge away from said optical axis or field of view.

11. The system of claim **1** wherein said vehicle support surface includes at least one opening in alignment with said optical axis or field of view; and

at least one fluid flow deflector on said vehicle support surface or cover plate in proximity to said at least one opening, said deflector including a fluid diverting lip passing through said at least one opening, said fluid diverting lip having a rolled or rounded contour to control a flow of liquid contaminates into said at least one opening.

12. The system of claim **1** wherein said vehicle support surface includes at least one opening in alignment with said optical axis or field of view;

a sensor housing with at least one optical window through which said optical axis or field of view is passed, said sensor housing disposed in proximity to an underside surface of said vehicle support surface; and

wherein said at least one optical window in said sensor housing is offset vertically and longitudinally from said

10

at least one opening in the vehicle support surface, along said optical axis or field of view.

13. The system of claim **12** wherein said sensor housing is biased against said underside surface of said vehicle support surface to maintain a relationship between said at least one optical windows and said at least one opening.

14. The system of claim **12** wherein said at least one optical windows includes at least one of an optically transparent nano-coating, an optically transparent hydrophobic coating, or another optically transparent surface coating which resists adhesion and/or encourages beading of liquid contaminates.

15. The system of claim **1** wherein said air discharge system includes at least one air knife, air blade assembly, or air nozzle.

16. The system of claim **1** wherein said optical component is a laser and said axis is a laser optical axis.

17. The system of claim **1** wherein said optical component is an imaging sensor and said field of view is an optical imaging sensor field of view.

18. An improved drive-over optical tire tread depth sensor system having an optical axis or field of view associated with an optical component disposed in proximity to a vehicle support surface or cover plate having at least one opening in alignment with the optical axis or field of view, the improvement comprising:

at least one environmental protection feature selected from a set of environmental protection features including a movable shutter associated with said at least one opening, a fluid flow deflecting element on said vehicle support surface or said cover plate in proximity to said at least one opening, an entrapping gutter below said at least one opening, a wiper mechanism configured to sweep a wiper across said at least one optical axis or field of view, and an air discharge assembly for periodically discharging a flow or blast of pressurize air across said at least one optical axis or field of view.

19. The system of claim **18** further including a drive-over trigger mechanism configured to provide a signal indicative of a vehicle approaching said at least one opening, and wherein said at least one environmental protection feature is activated in response to said signal.

20. A method for preventing an accumulation of environmental contaminates, debris, or liquids on a surface of a drive-over optical tire tread depth sensor system disposed below a vehicle support surface or cover plate having at least one opening in alignment with an illuminating laser optical axis or an optical imaging sensor field of view, comprising:

activating an air discharge assembly to discharge pressurize air to displace accumulated contaminates, debris, or liquids from said illuminating laser optical axis or said optical imaging sensor field of view.

21. The method of claim **20** wherein said air discharge assembly is activated either in response to activation of a drive-over trigger mechanism, on a fixed cyclical basis, or on a fixed time basis.

22. The method of claim **20** further including monitoring a quality of images acquired by said drive-over optical tire tread depth sensor system to identify the presence of accumulating debris or contaminates on said illuminating laser optical axis or said optical imaging sensor field of view, and

wherein activation of said air discharge assembly is responsive to said identified presence of accumulated debris or contaminates.

23. The method of claim **20** further including regulating operation of a shutter assembly to limit ingress of said environmental contaminates, debris, or liquids through said at

least one opening by selectively opening said shutter assembly only during a period of acquisition of tire tread images by said optical imaging sensor.

* * * * *