



US009017456B2

(12) **United States Patent**  
**Becze et al.**

(10) **Patent No.:** **US 9,017,456 B2**  
(45) **Date of Patent:** **Apr. 28, 2015**

(54) **APPARATUS FOR WATER RECOVERY INCLUDING STACKABLE DESICCANT TRAYS**

(56) **References Cited**

U.S. PATENT DOCUMENTS

(71) Applicant: **Z124**, George Town (KY)

1,772,089 A 8/1930 Smith  
2,026,935 A 1/1936 Downs

(72) Inventors: **Charles Becze**, Oakville (CA); **James Ball**, Hamilton (CA); **David Blatt**, Oakville (CA); **Michael J. Flynn**, Burlington (CA); **Richard Teltz**, Hamilton (CA)

(Continued)

FOREIGN PATENT DOCUMENTS

GB 513562 10/1939  
GB 518473 2/1940

(73) Assignee: **Z124**, George Town (KY)

OTHER PUBLICATIONS

(\*) Notice: Subject to any disclaimer, the term of this patent is extended or adjusted under 35 U.S.C. 154(b) by 158 days.

Hung et al. "Integration of Desiccant tray unit with internal cooling for aeration of paddy silo in humid tropical climate," Biosystems Engineering, Jan. 2009, vol. 102, No. 1, pp. 75-82.

(Continued)

(21) Appl. No.: **13/714,006**

(22) Filed: **Dec. 13, 2012**

*Primary Examiner* — Christopher P Jones

(65) **Prior Publication Data**

(74) *Attorney, Agent, or Firm* — Sheridan Ross P.C.

US 2013/0319250 A1 Dec. 5, 2013

**Related U.S. Application Data**

(57) **ABSTRACT**

(60) Provisional application No. 61/655,316, filed on Jun. 4, 2012.

(51) **Int. Cl.**  
**B01D 53/02** (2006.01)  
**B01D 53/26** (2006.01)  
(Continued)

A device recovers water from an ambient airstream. The device includes a chamber having a group of trays that hold respective amounts of liquid desiccant. A foam media element in each tray absorbs the desiccant to increase an exposed surface of the desiccant to the airstream. Fans and valves are used to control airflow through the device. A charge cycle circulates air through the device to remove water vapor from the airstream. A subsequent extraction cycle removes water collected in the liquid desiccant by a condenser communicating with the chamber. An integral heat exchanger adds heat to the chamber during the extraction cycle. A controller is used to integrate and control device operation. The desiccant trays may be selectively configurable in an array to best suit the intended installation. The trays may be arranged in column and row configurations, along with adjustable airflow patterns between each of the trays.

(52) **U.S. Cl.**  
CPC ..... **B01D 53/263** (2013.01); **Y10T 29/49826** (2015.01); **Y10T 29/49396** (2015.01); **F25B 17/02** (2013.01); **F25D 21/14** (2013.01); **F24F 3/1417** (2013.01); **F25B 43/00** (2013.01);  
(Continued)

(58) **Field of Classification Search**  
USPC ..... 96/112, 140, 141; 95/117, 118, 199, 95/223, 231  
See application file for complete search history.

**26 Claims, 14 Drawing Sheets**

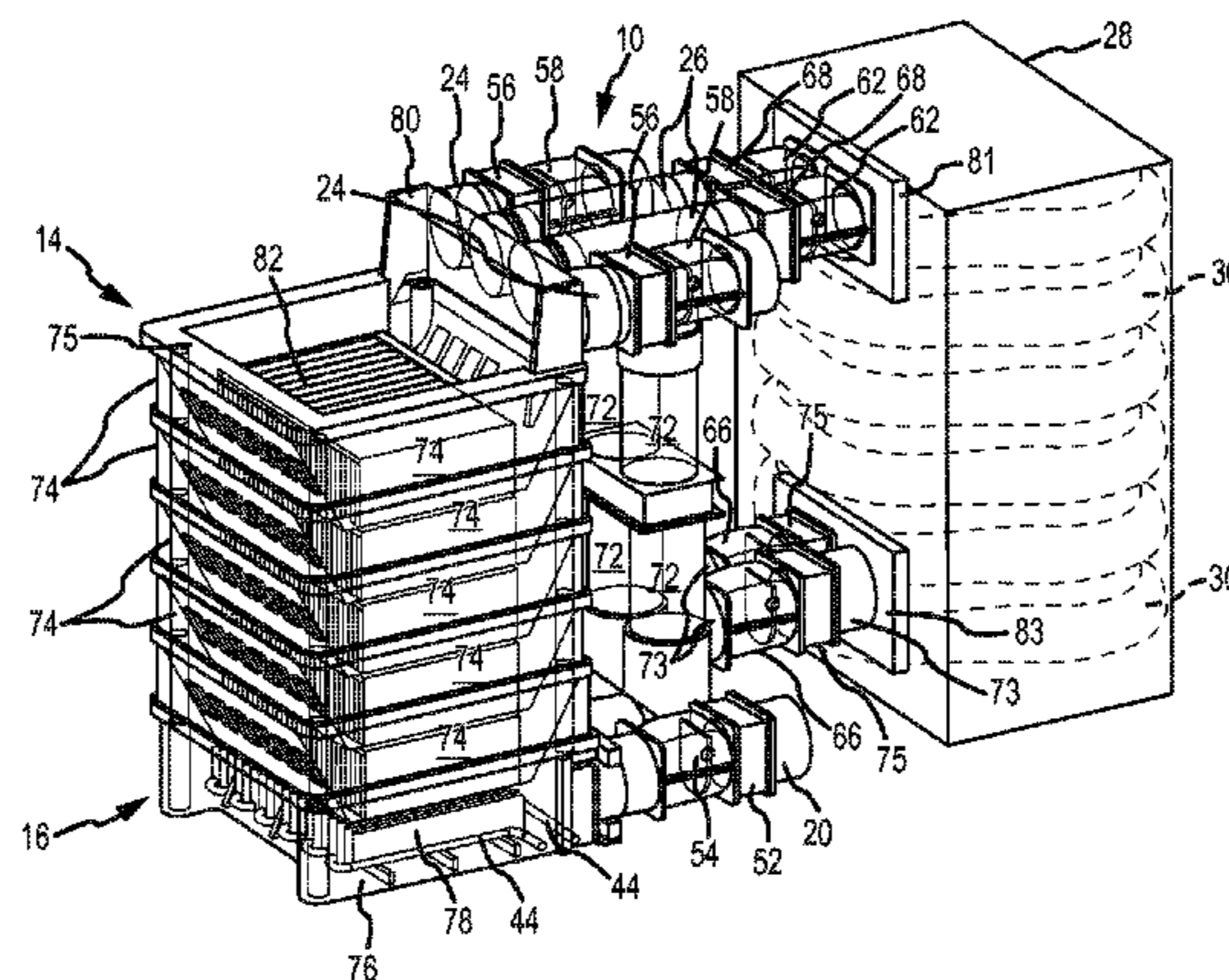

- (51) **Int. Cl.**  
**F25B 17/02** (2006.01)  
**F25D 21/14** (2006.01)  
**F24F 3/14** (2006.01)  
**F25B 43/00** (2006.01)  
**B01D 53/18** (2006.01)  
**B01D 53/04** (2006.01)  
**B01D 53/28** (2006.01)  
**F25B 37/00** (2006.01)

2012/0176978 A1 7/2012 Kim  
 2012/0199211 A1 8/2012 Schroder et al.  
 2013/0319244 A1 12/2013 Ball et al.

OTHER PUBLICATIONS

International Search Report and Written Opinion for International (PCT) Patent Application No. PCT/IB2013/001858, mailed Dec. 4, 2013 4 pages.

Notice of Allowance for U.S. Appl. No. 13/660,499, mailed May 9, 2014 11 pages.

Notice of Allowance for U.S. Appl. No. 13/713,972, mailed May 21, 2014 11 pages.

Notice of Allowance for U.S. Appl. No. 13/660,525, mailed May 12, 2014 11 pages.

Notice of Allowance for U.S. Appl. No. 13/693,398, mailed May 16, 2014 11 pages.

Notice of Allowance for U.S. Appl. No. 13/660,602, mailed May 14, 2014 11 pages.

Notice of Allowance for U.S. Appl. No. 13/660,639, mailed May 30, 2014 9 pages.

Notice of Allowance for U.S. Appl. No. 13/693,418, mailed May 29, 2014 10 pages.

Website "Co-Generation," E. Power Generation, Marlow Industries, Inc., 2012, 1 page, retrieved from [www.marlow.com/resources/knowledgebase/ii-tem-primary-uses/e-power-generation/co-generation.html](http://www.marlow.com/resources/knowledgebase/ii-tem-primary-uses/e-power-generation/co-generation.html).

Website "Direct Generation," E. Power Generation, Marlow Industries, Inc., 2012, 1 page, retrieved from [www.marlow.com/resources/knowledgebase/ii-tem-primary-uses/e-power-generation/direct-generation.html](http://www.marlow.com/resources/knowledgebase/ii-tem-primary-uses/e-power-generation/direct-generation.html).

Website "Energy Harvesting," E. Power Generation, Marlow Industries, Inc., 2012, 1 page, retrieved from [www.marlow.com/resources/knowledgebase/ii-tem-primary-uses/e-power-generation/energy-harvesting.html](http://www.marlow.com/resources/knowledgebase/ii-tem-primary-uses/e-power-generation/energy-harvesting.html).

Website "Waste Heat Recovery," E. Power Generation, Marlow Industries, Inc., 2012, 1 page, retrieved from [www.marlow.com/resources/knowledgebase/ii-tem-primary-uses/e-power-generation/waste-heat-recovery.html](http://www.marlow.com/resources/knowledgebase/ii-tem-primary-uses/e-power-generation/waste-heat-recovery.html).

Venkatasubramanian, "Efficient Thermoelectric Power Conversion of Waste Heat for Deployed Forces (EW-1651)," SERDP, Arlington, VA, 2012, 3 pages, retrieved from [www.serdp.org/content/view/pdf/6791](http://www.serdp.org/content/view/pdf/6791).

Notice of Allowance for U.S. Appl. No. 13/908,576 mailed Jun. 30, 2014, 8 pages.

Corrected Notice of Allowance for U.S. Appl. No. 13/713,972, mailed Aug. 1, 2014 4 pages.

Official Action for U.S. Appl. No. 13/660,572 mailed Jun. 26, 2014, 8 pages.

Official Action for U.S. Appl. No. 13/660,620 mailed Jul. 16, 2014, 5 pages.

Official Action for U.S. Appl. No. 13/693,451 mailed Aug. 19, 2014, 5 pages.

U.S. Appl. No. 13/660,499, filed Oct. 25, 2012, Ball et al.

U.S. Appl. No. 13/713,972, filed Dec. 13, 2012, Becze et al.

U.S. Appl. No. 13/660,525, filed Oct. 25, 2012, Ball et al.

U.S. Appl. No. 13/693,398, filed Dec. 4, 2012, Becze et al.

U.S. Appl. No. 13/660,572, filed Oct. 25, 2012, Ball et al.

U.S. Appl. No. 13/660,602, filed Oct. 25, 2012, Ball et al.

U.S. Appl. No. 13/660,620, filed Oct. 25, 2012, Ball et al.

U.S. Appl. No. 13/660,639, filed Oct. 25, 2012, Ball et al.

U.S. Appl. No. 13/693,418, filed Dec. 4, 2012, Becze et al.

U.S. Appl. No. 13/693,451, filed Dec. 4, 2012, Becze et al.

U.S. Appl. No. 13/723,113, filed Dec. 20, 2012, Becze et al.

U.S. Appl. No. 13/746,824, filed Mar. 26, 2013, Ball et al.

Website "Waste Heat Recovery Applications," Cool Energy, 2 pages, Jul. 16, 2012 webarchive, retrieved from ([web/archive.org/web/20120716024750/http://www.coolenergyinc.com/wasteheat.html](http://web.archive.org/web/20120716024750/http://www.coolenergyinc.com/wasteheat.html)).

Website "Waste heat recovery unit," Wikipedia, modified May 28, 2012, retrieved from ([web/archive.org/web/20120815192859/http://en.wikipedia.org/wiki/Waste\\_heat\\_rec...](http://web.archive.org/web/20120815192859/http://en.wikipedia.org/wiki/Waste_heat_rec...)).

Bhatia "Desiccant Cooling Technology Resource Guide," Continuing Education and Development, Inc. Jan. 2000, 115 pages.

- (52) **U.S. Cl.**  
 CPC ..... **B01D53/18** (2013.01); **B01D 53/26** (2013.01); **B01D 53/0454** (2013.01); **B01D 53/28** (2013.01); **Y02B 30/62** (2013.01); **Y02B 60/50** (2013.01); **F25B 37/00** (2013.01)

(56) **References Cited**

U.S. PATENT DOCUMENTS

2,804,935	A	9/1957	Hutchinson
2,804,941	A	9/1957	Hutchinson
2,995,203	A	8/1961	Maurer
3,254,473	A	6/1966	Fryar et al.
3,254,497	A	6/1966	Henry et al.
3,257,738	A	6/1966	Thomas
3,288,448	A	11/1966	Patterson et al.
4,209,364	A	6/1980	Rothschild
4,330,627	A	5/1982	Thomas et al.
4,612,447	A	9/1986	Rowe
4,722,018	A	1/1988	Pohl
4,842,045	A	6/1989	Reinmuller
4,971,610	A	11/1990	Henderson
5,988,283	A	11/1999	Gann
6,059,934	A	5/2000	Stober et al.
6,134,903	A	10/2000	Potnis et al.
6,156,102	A	12/2000	Conrad et al.
6,216,483	B1	4/2001	Potnis et al.
6,216,489	B1	4/2001	Potnis et al.
6,336,957	B1	1/2002	Tsymerman
6,463,891	B2	10/2002	Algrain et al.
6,536,215	B1	3/2003	Vikstrom
6,562,303	B1	5/2003	Ragnarsson
6,641,947	B1	11/2003	Molloy et al.
6,717,284	B2	4/2004	Lin
6,729,133	B1	5/2004	Sorter et al.
6,800,965	B1	10/2004	Turner et al.
6,823,151	B2	11/2004	Carlson et al.
6,898,943	B2	5/2005	Tanaka
6,899,749	B2	5/2005	Johansson
6,938,683	B2	9/2005	Lin
6,981,915	B2	1/2006	Moore et al.
7,157,802	B2	1/2007	Bodkin
7,228,887	B2	6/2007	Chen et al.
7,377,958	B2	5/2008	Cunanan
7,569,194	B2	8/2009	Russell
7,780,762	B2	8/2010	Blondel et al.
7,863,839	B2	1/2011	Schuricht et al.
7,969,029	B2	6/2011	Vitagliano
8,021,542	B2	9/2011	Kirts
2001/0015077	A1	8/2001	Potnis et al.
2002/0005271	A1	1/2002	Weiss et al.
2004/0031282	A1	2/2004	Kopko
2006/0156750	A1	7/2006	Lowenstein et al.
2006/0206996	A1	9/2006	Lumbert
2006/0257258	A1	11/2006	Zwebner
2007/0280400	A1	12/2007	Keller
2009/0133414	A1	5/2009	Vetrovec et al.
2009/0175726	A1	7/2009	Rosati et al.
2010/0083530	A1	4/2010	Weisselberg et al.
2011/0138832	A1	6/2011	Al-Hadhrami et al.
2011/0220729	A1	9/2011	Bucknell
2011/0232485	A1	9/2011	Ellsworth
2011/0283118	A1	11/2011	Maniktala
2012/0176078	A1	7/2012	English et al.

(56)

**References Cited**

OTHER PUBLICATIONS

Callier "Military Aircraft May Produce Electricity from Waste Heat," RenewableEnergyWorld.com, Oct. 15, 2009, 1 page, found at ([www.renewableenergyworld.com/rea/news/article/2009/10/the-future-of-electricity-may-be-found-in-environmentally-friendly-thermoelectric-cells](http://www.renewableenergyworld.com/rea/news/article/2009/10/the-future-of-electricity-may-be-found-in-environmentally-friendly-thermoelectric-cells)).

International Preliminary Report on Patentability for International Patent Application No. PCT/IB2013/001858, mailed Dec. 18, 2014 8 pages.

Notice of Allowance for U.S. Appl. No. 13/660,572, mailed Dec. 4, 2014, 5 pages.

Official Action for U.S. Appl. No. 13/660,620 mailed Dec. 23, 2014, 8 pages.

Notice of Allowance for U.S. Appl. No. 13/693,451, mailed Jan. 13, 2015, 9 pages.

Restriction Requirement for U.S. Appl. No. 13/723,113, mailed Nov. 12, 2014, 12 pages.

Notice of Allowance for U.S. Appl. No. 13/723,113, mailed Jan. 27, 2015, 14 pages.

Official Action for U.S. Appl. No. 13/746,824, mailed Jan. 21, 2015, 7 pages.

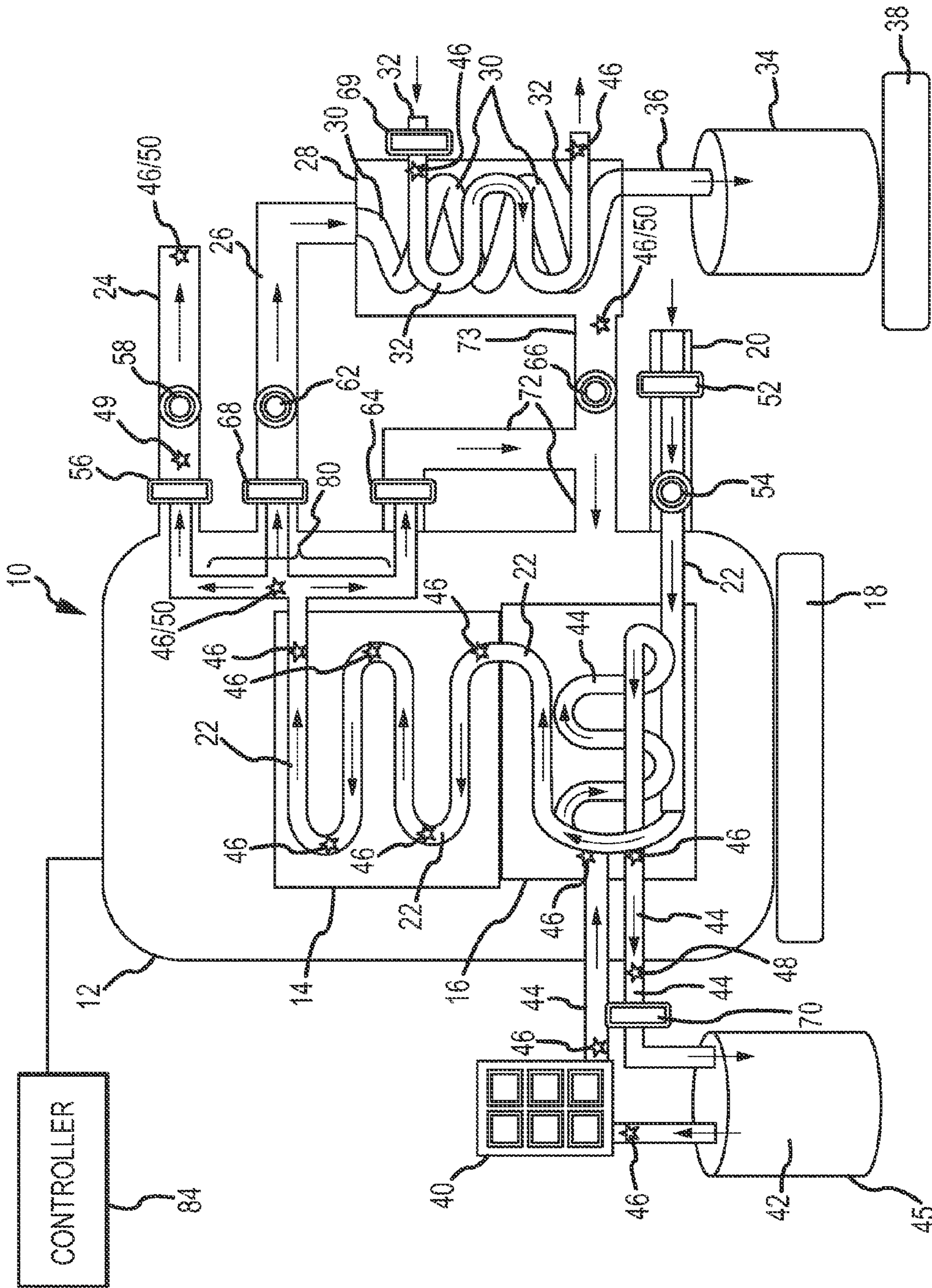

FIG. 1

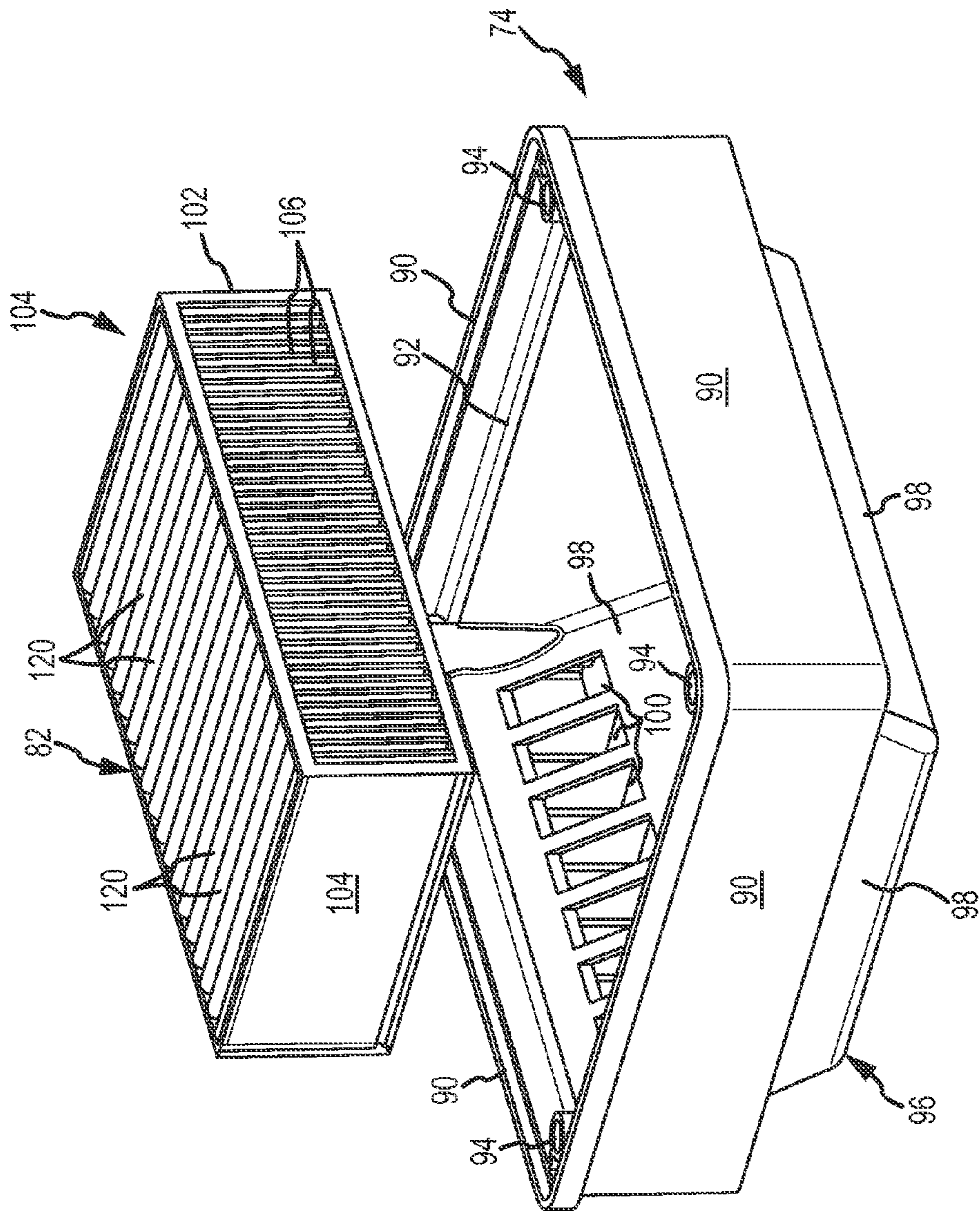

FIG. 2

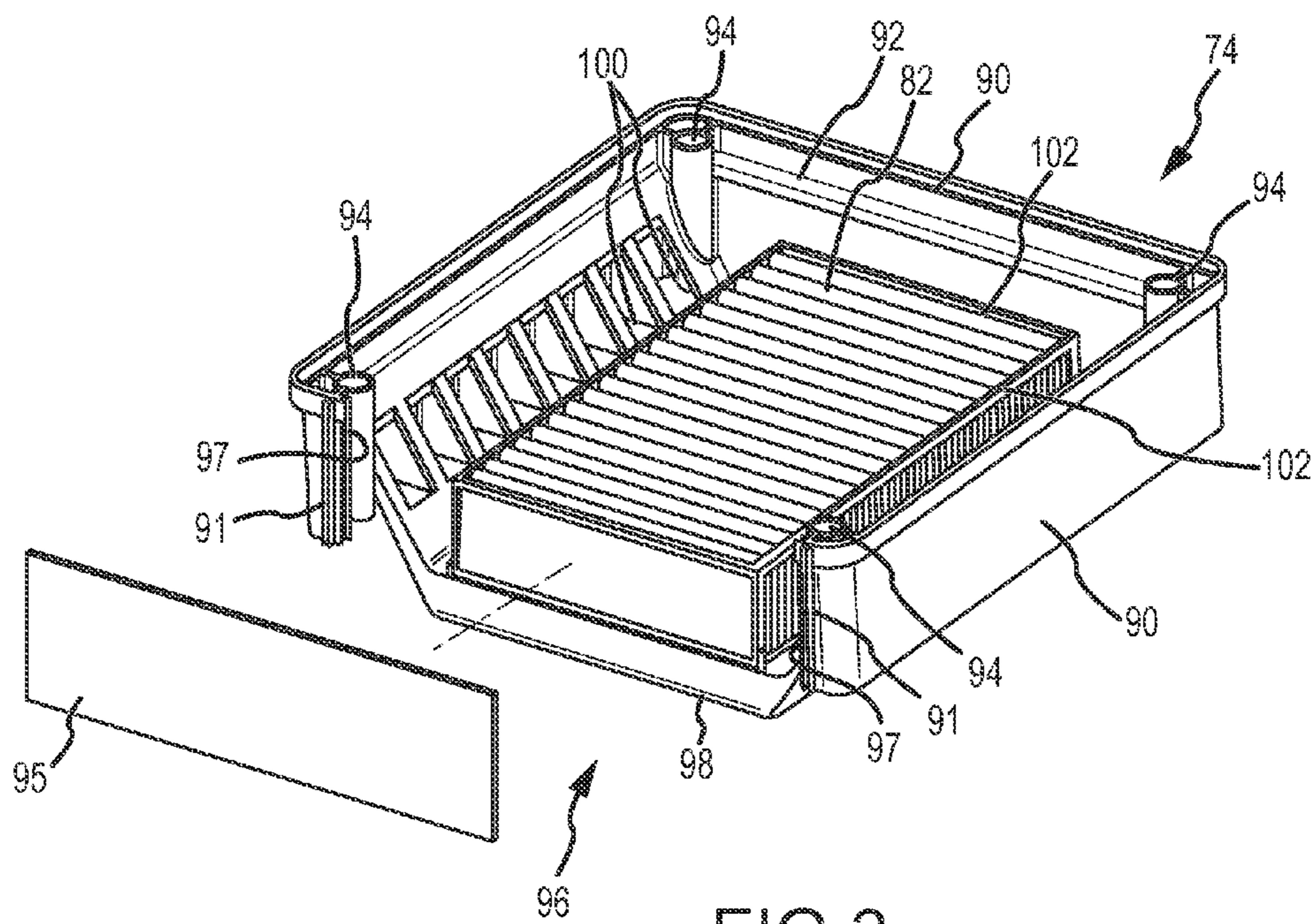

FIG. 3

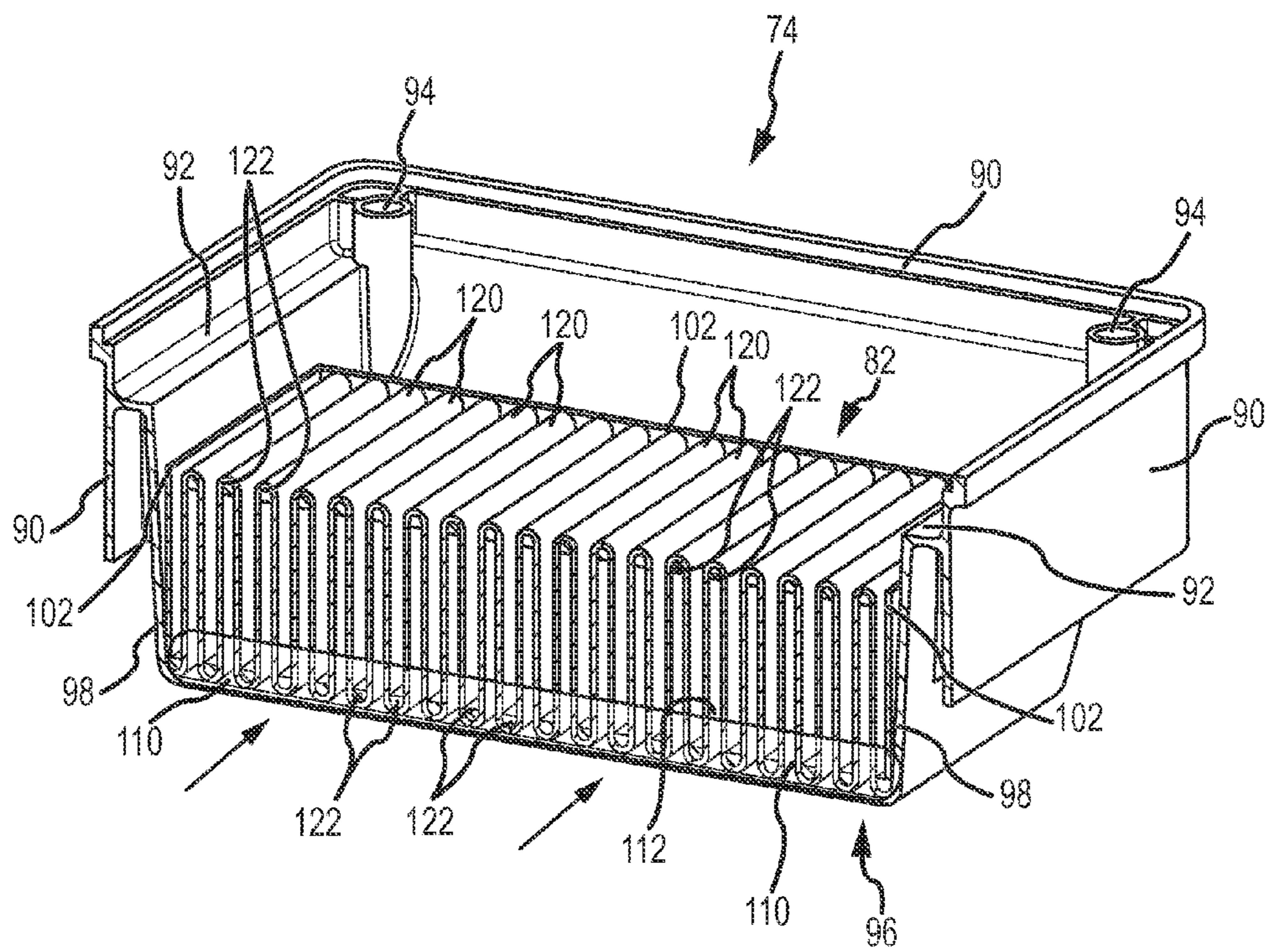

FIG. 4

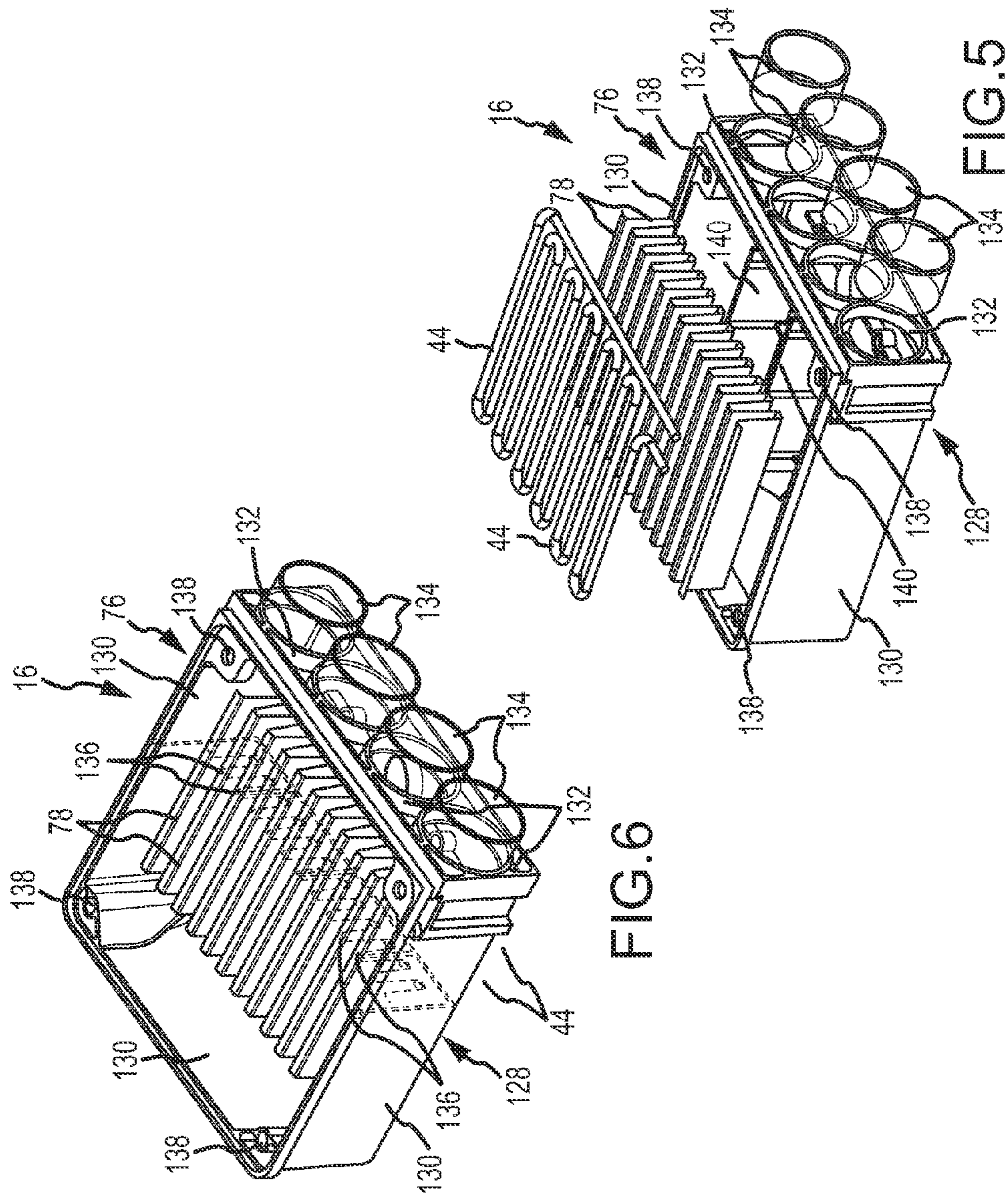

FIG. 6

FIG. 5



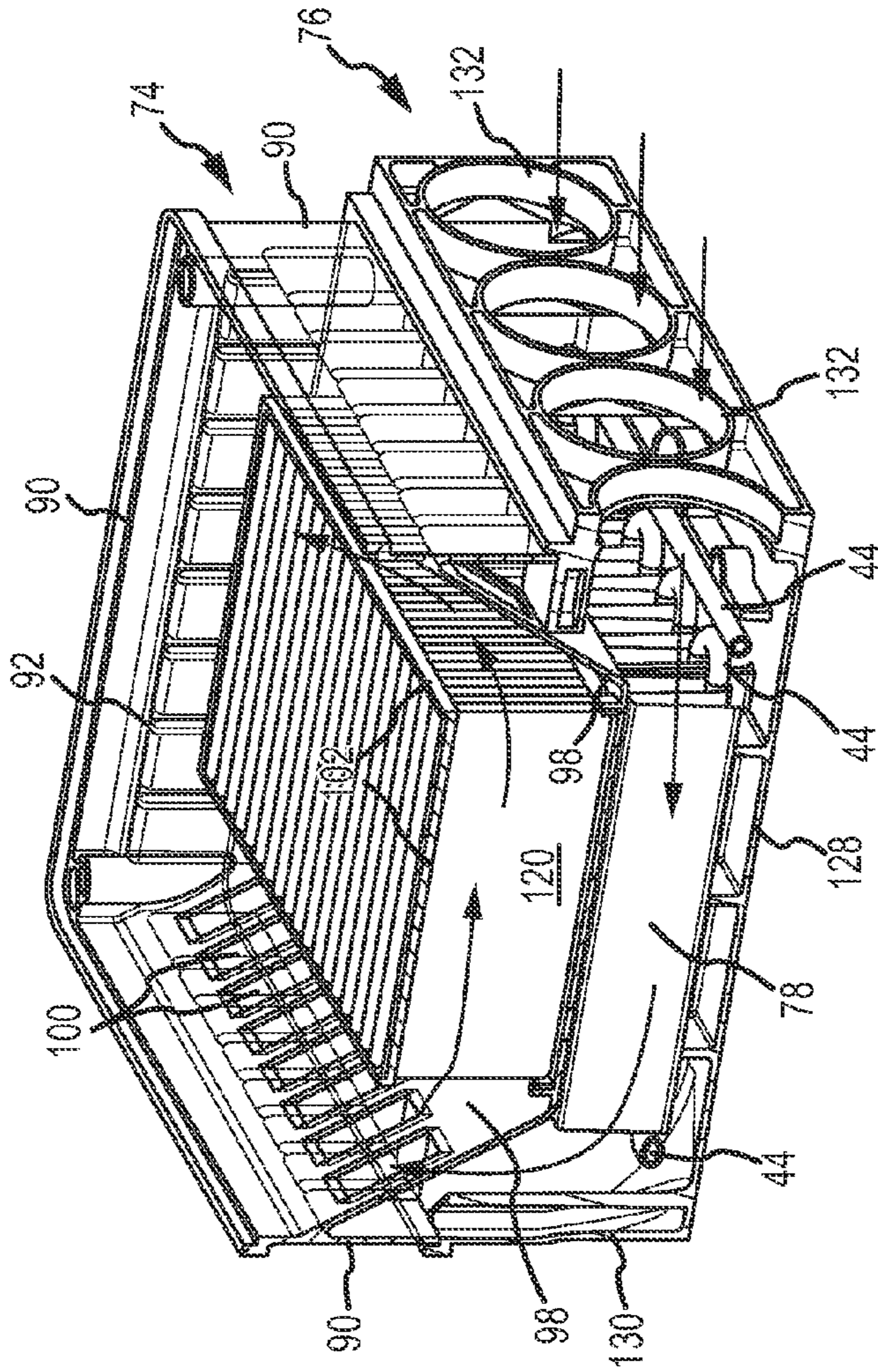

FIG. 7

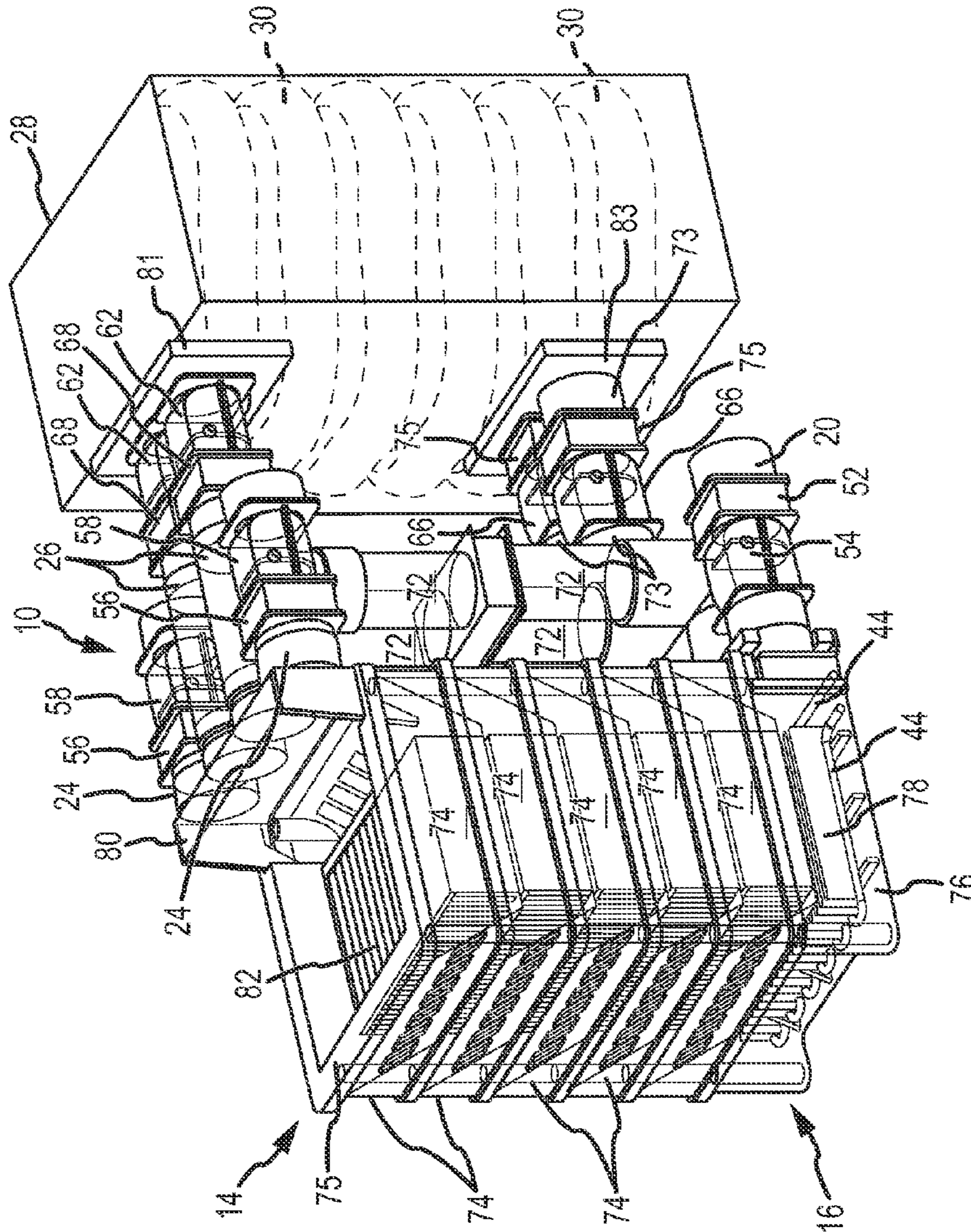

FIG.8

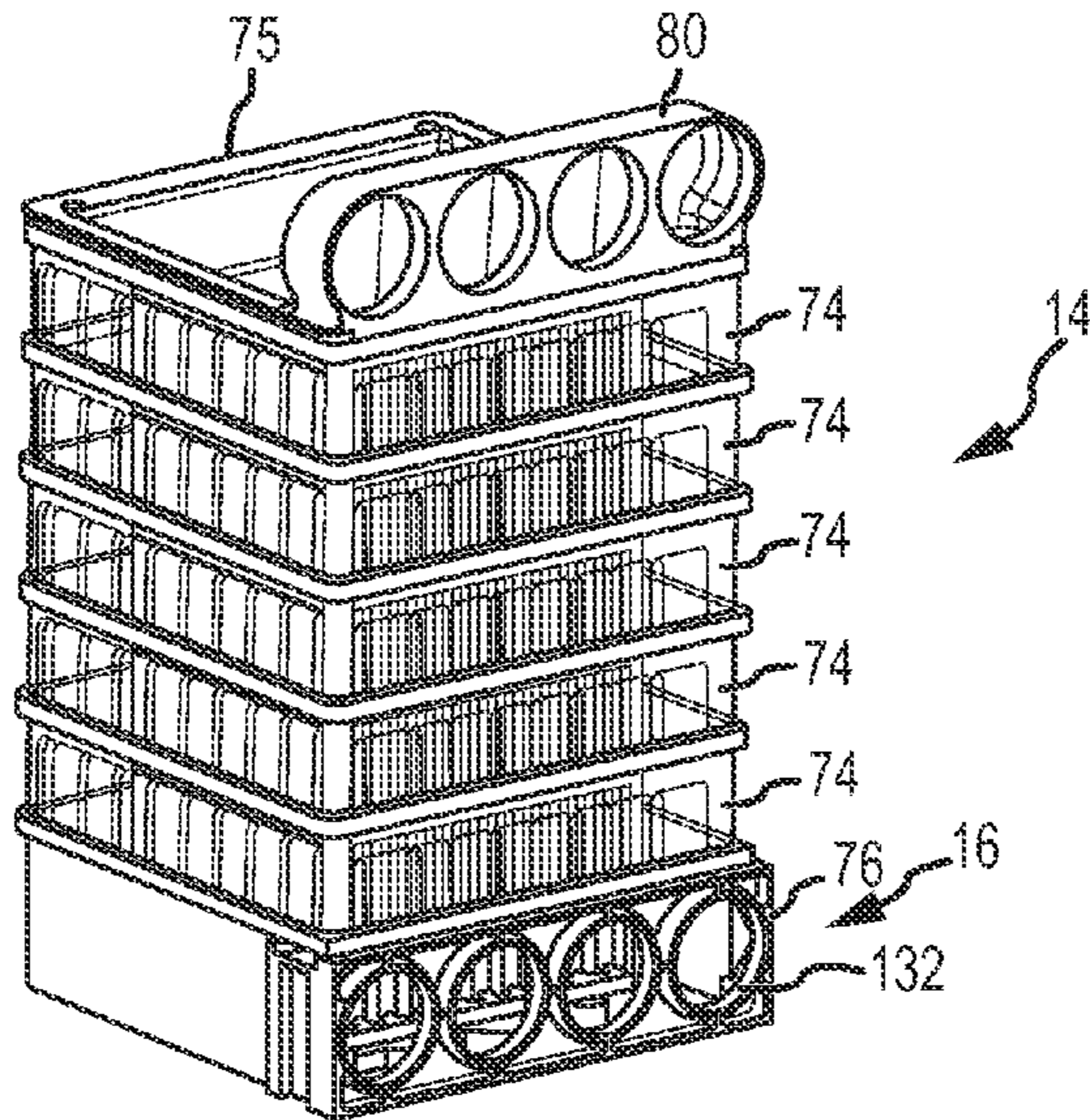

FIG. 9A

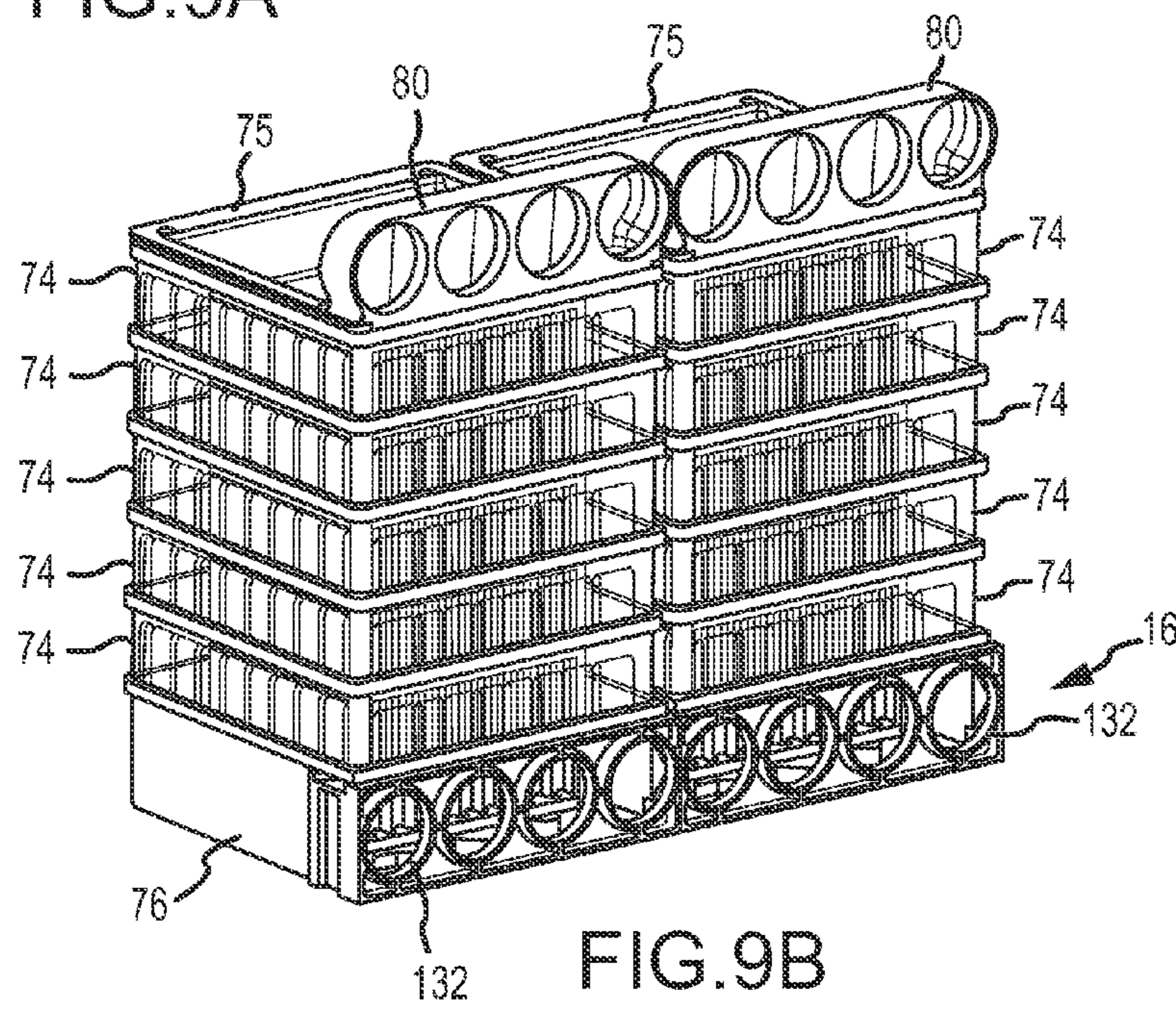

FIG. 9B

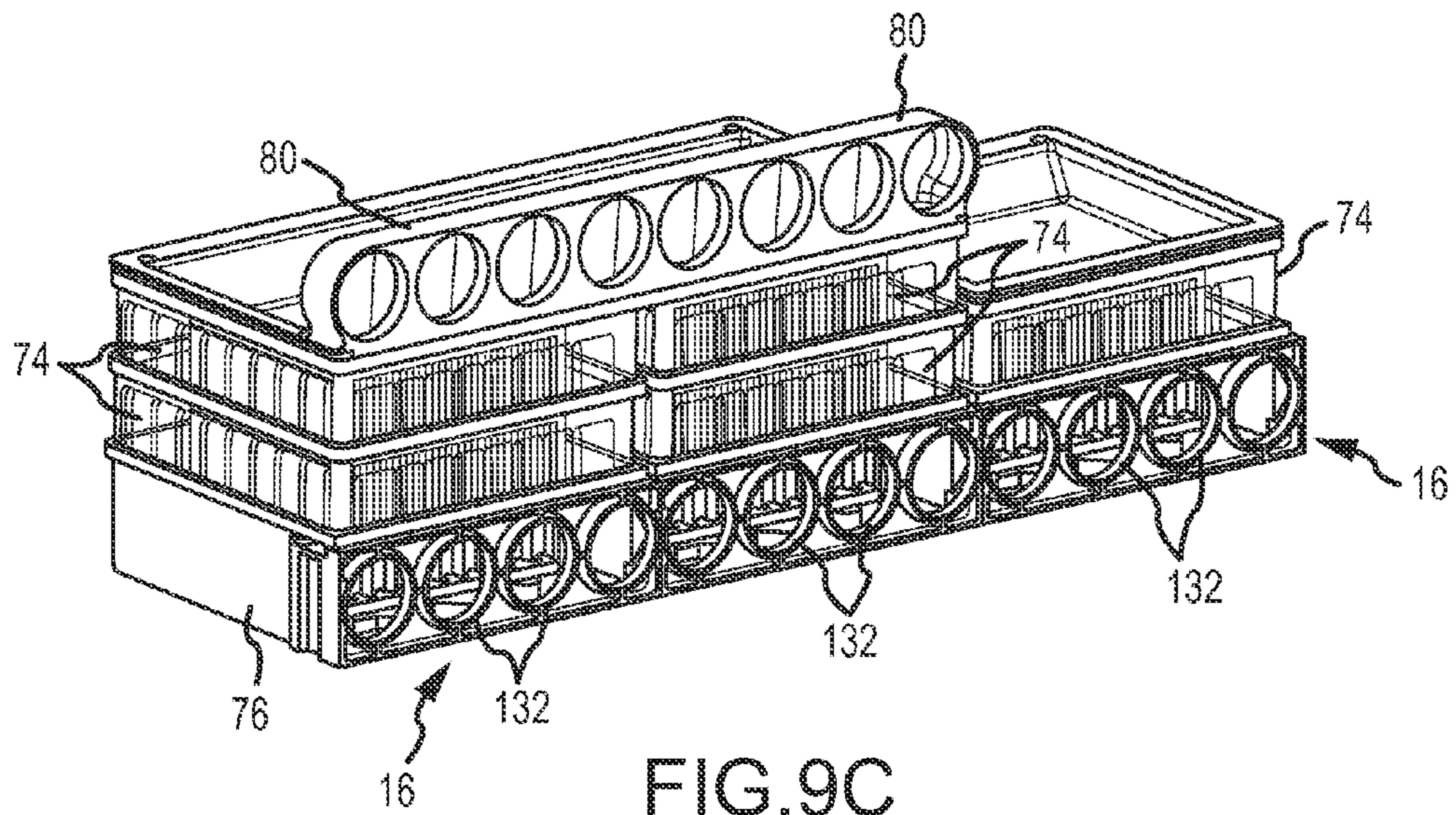

FIG. 9C

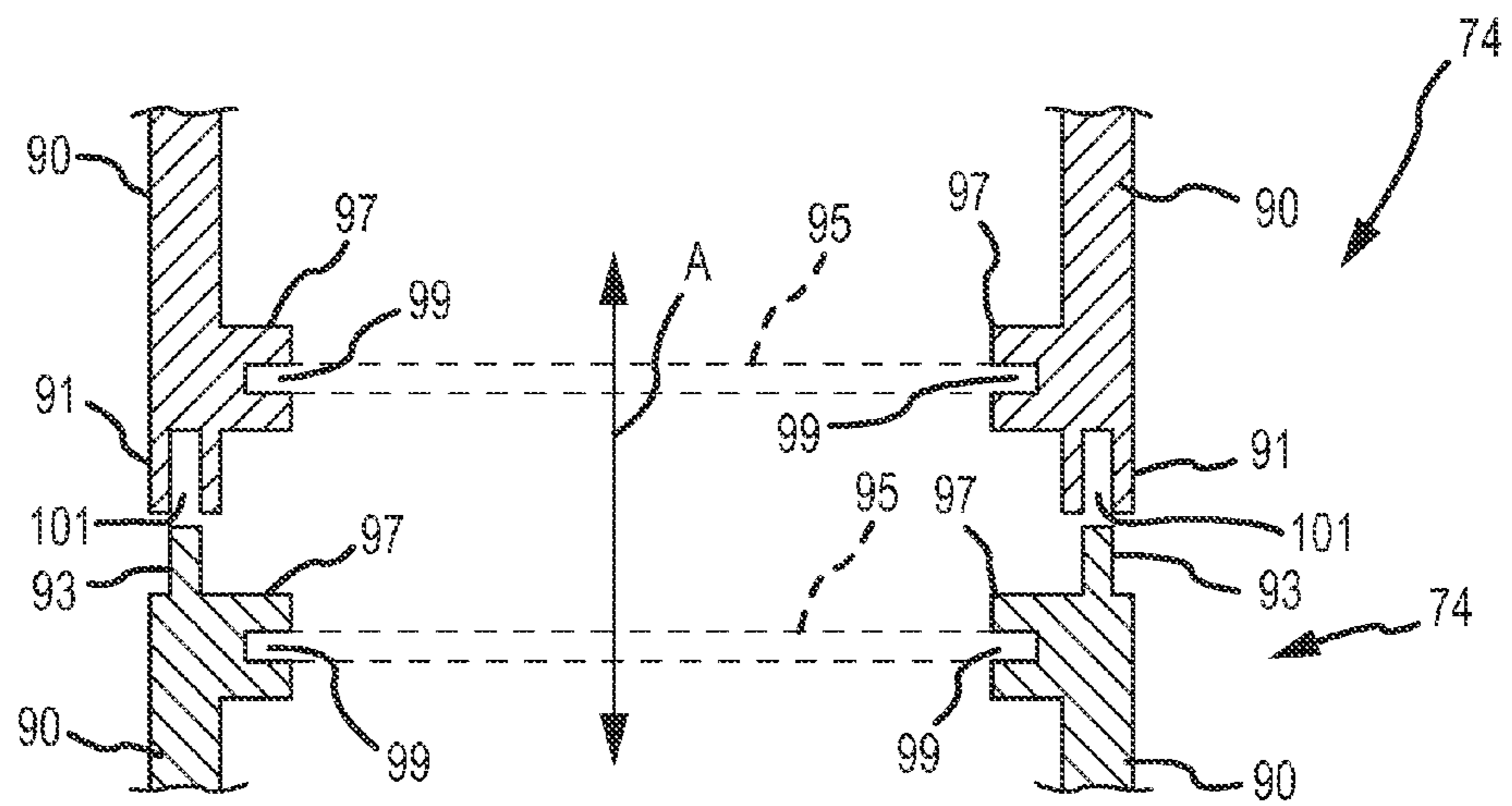

FIG. 9D

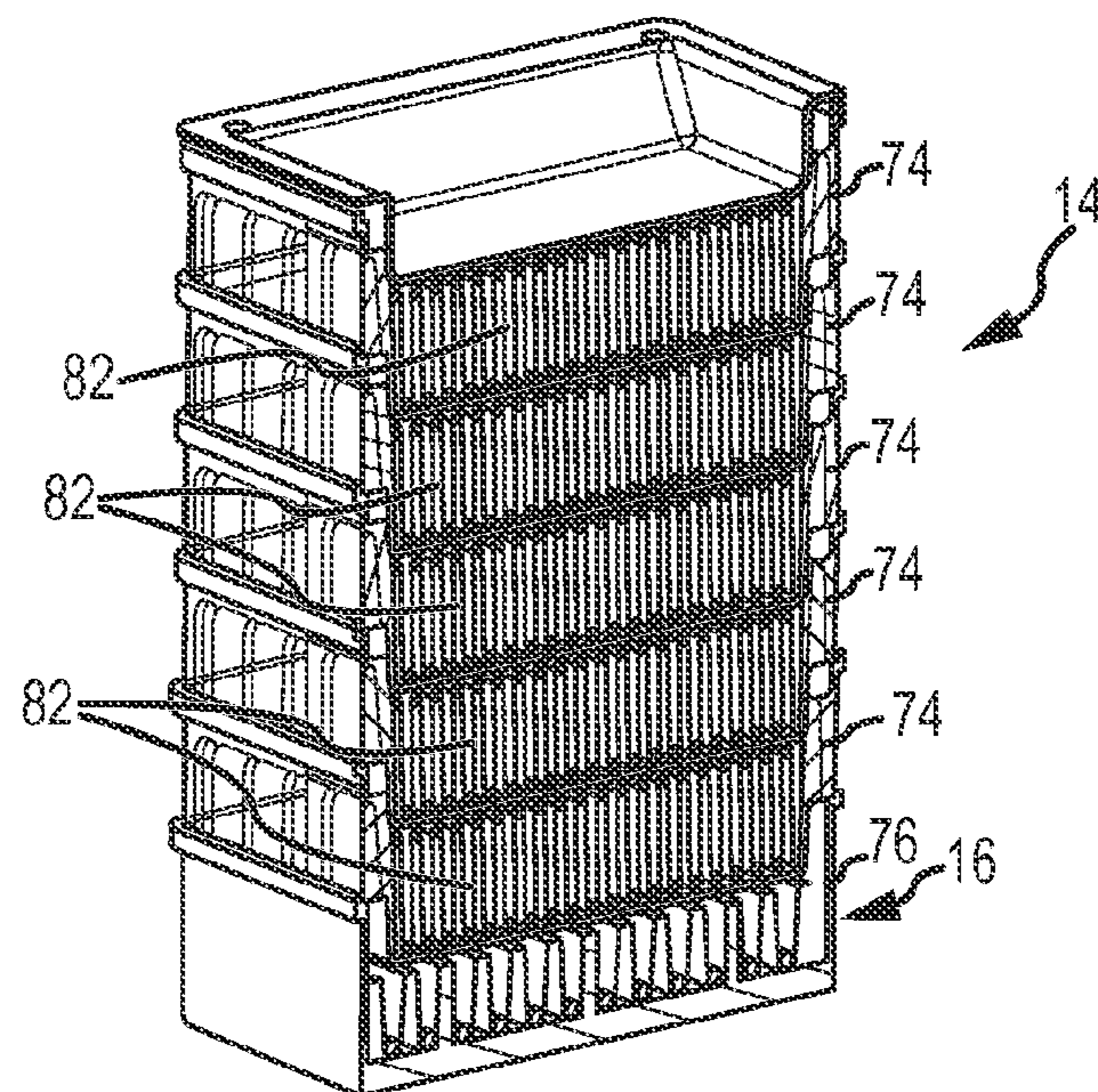

FIG. 10

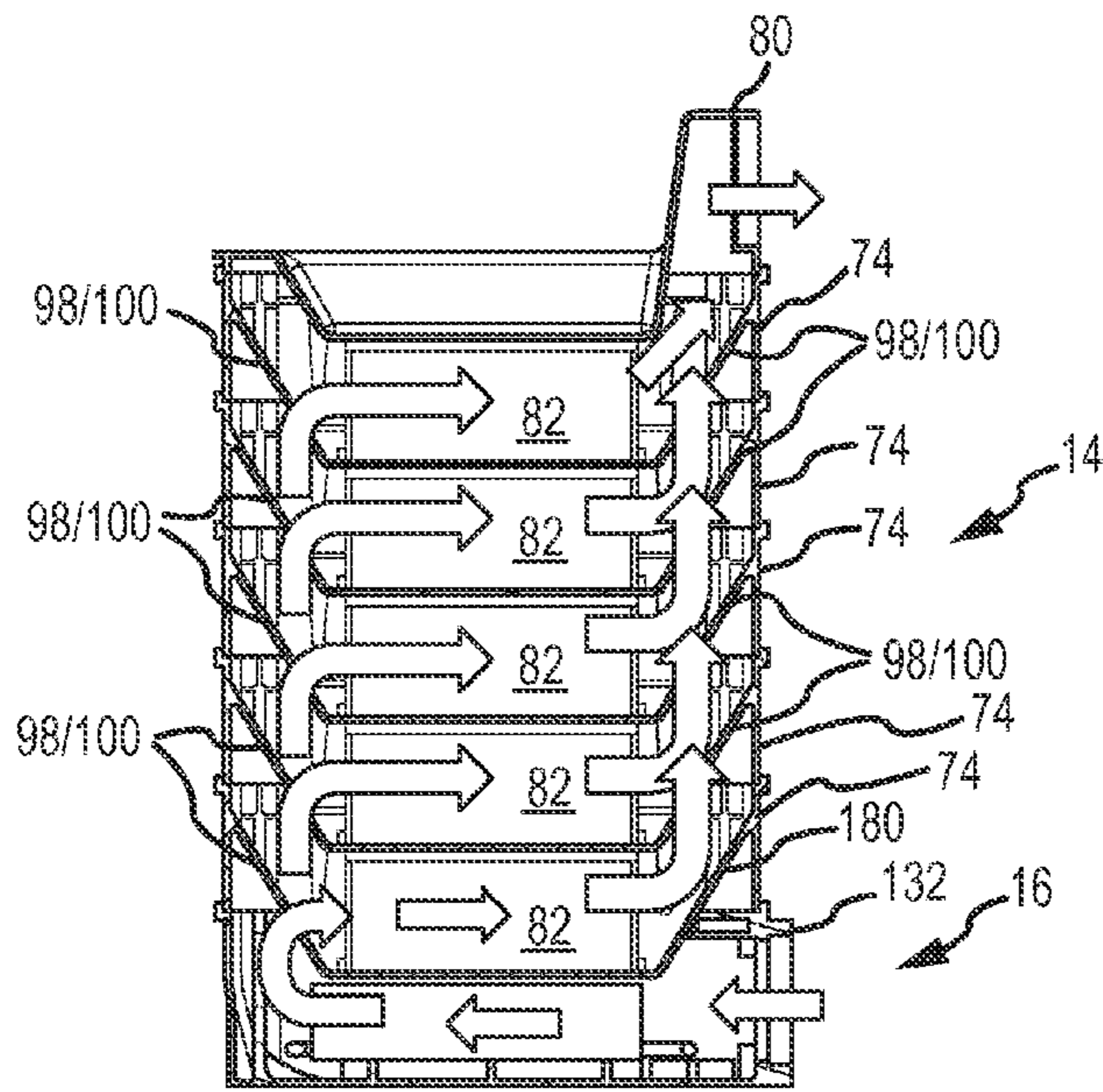

FIG. 11

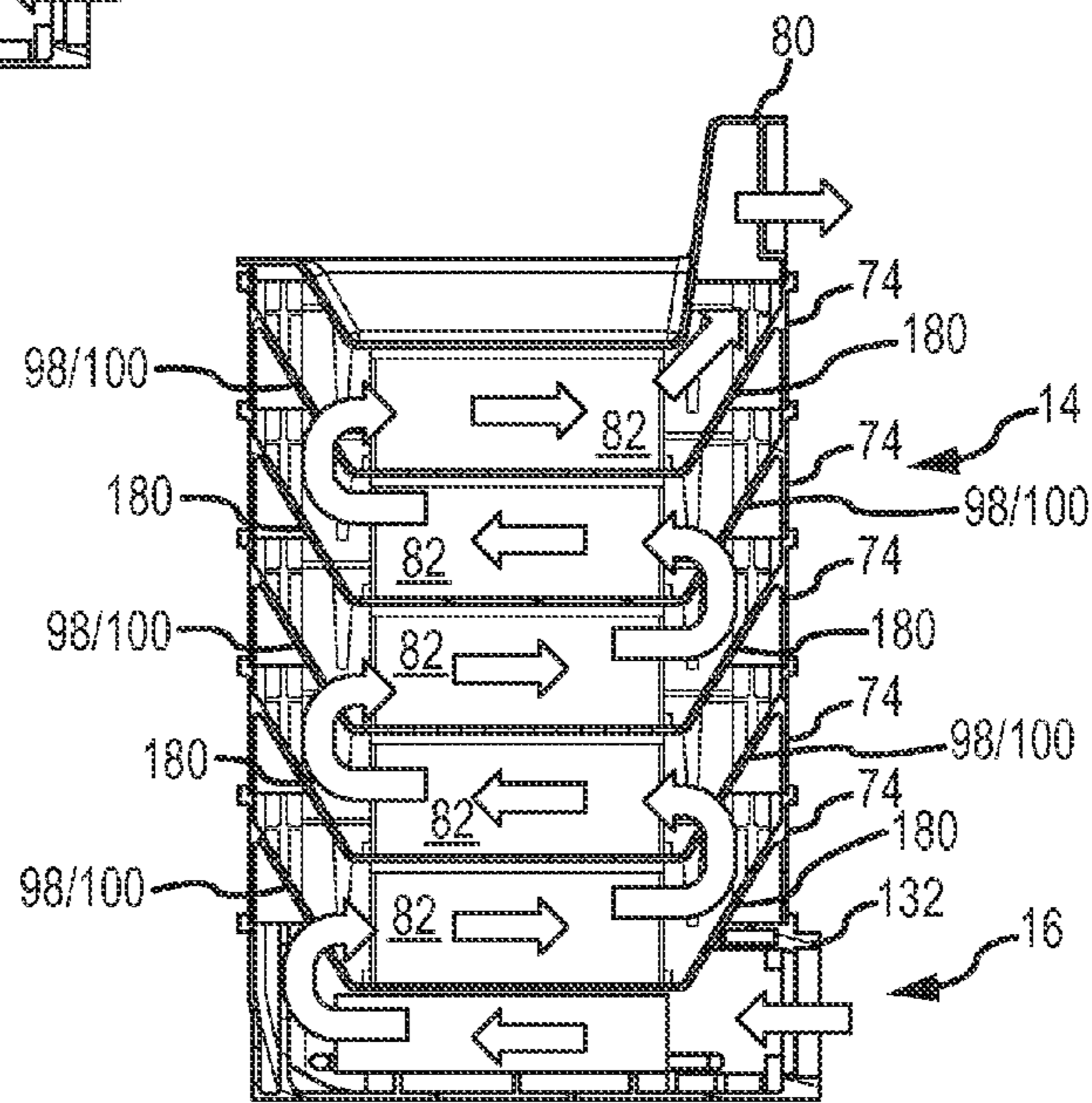

FIG. 12

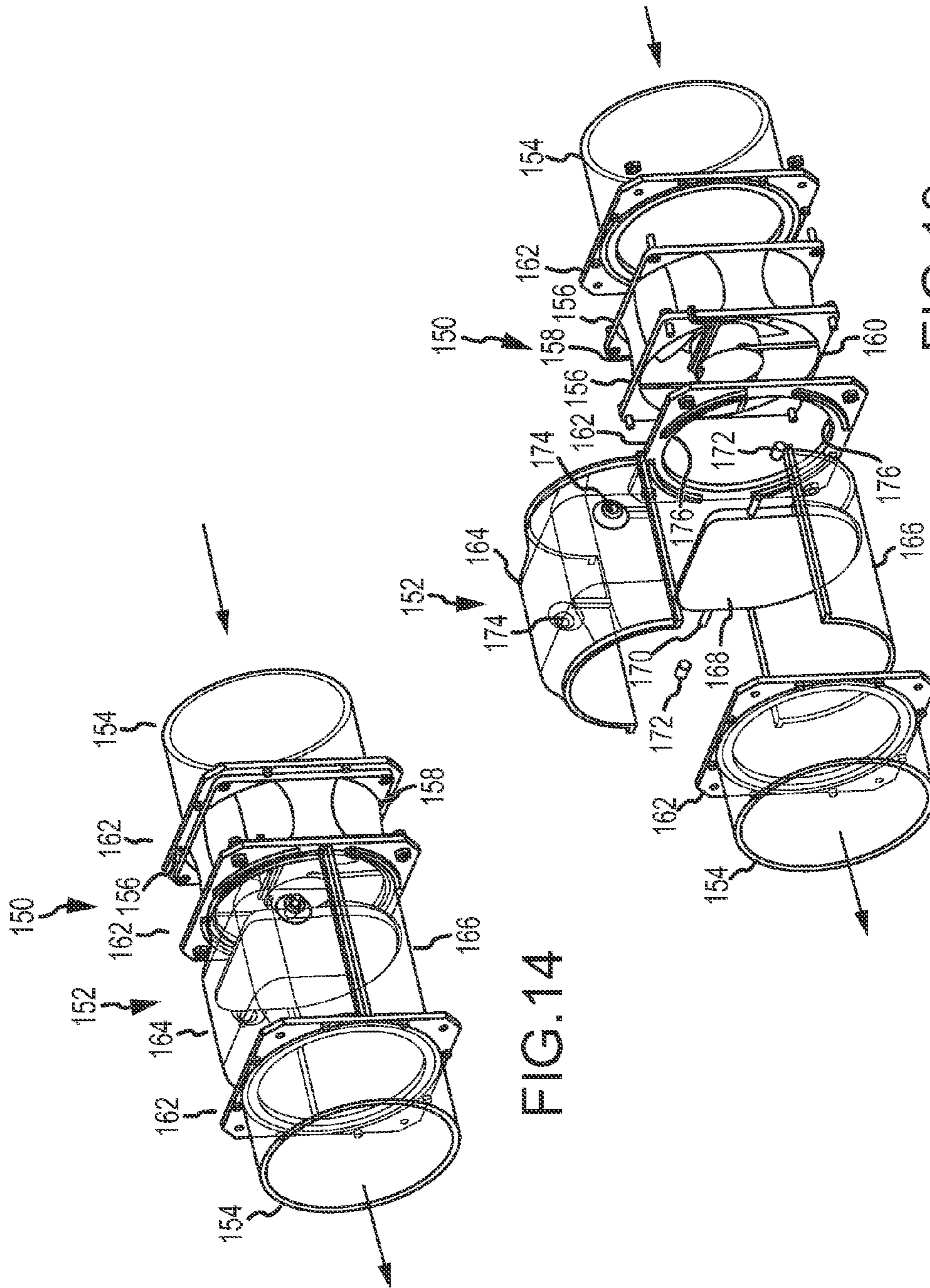

FIG. 13

FIG. 14

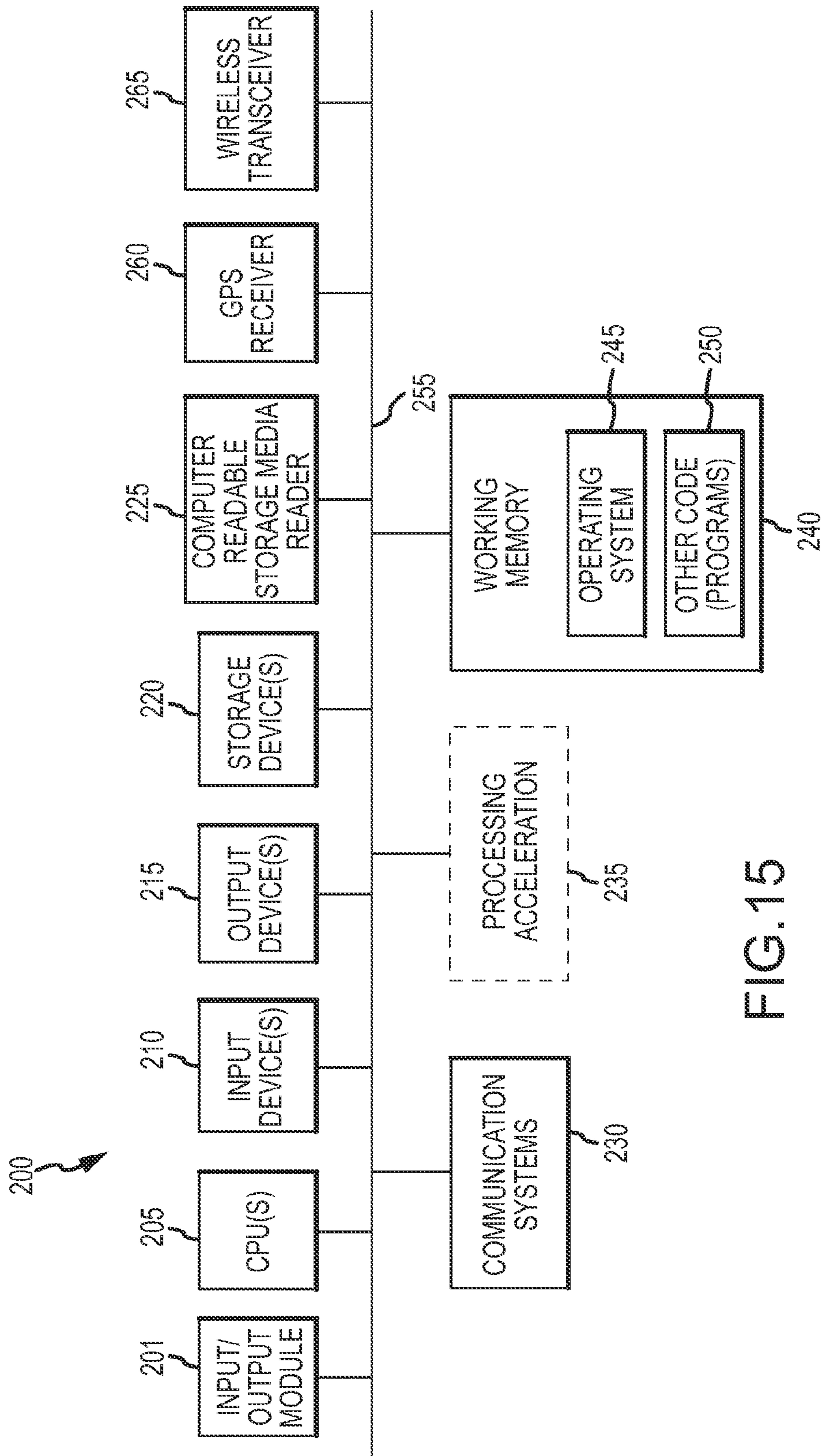

FIG.15



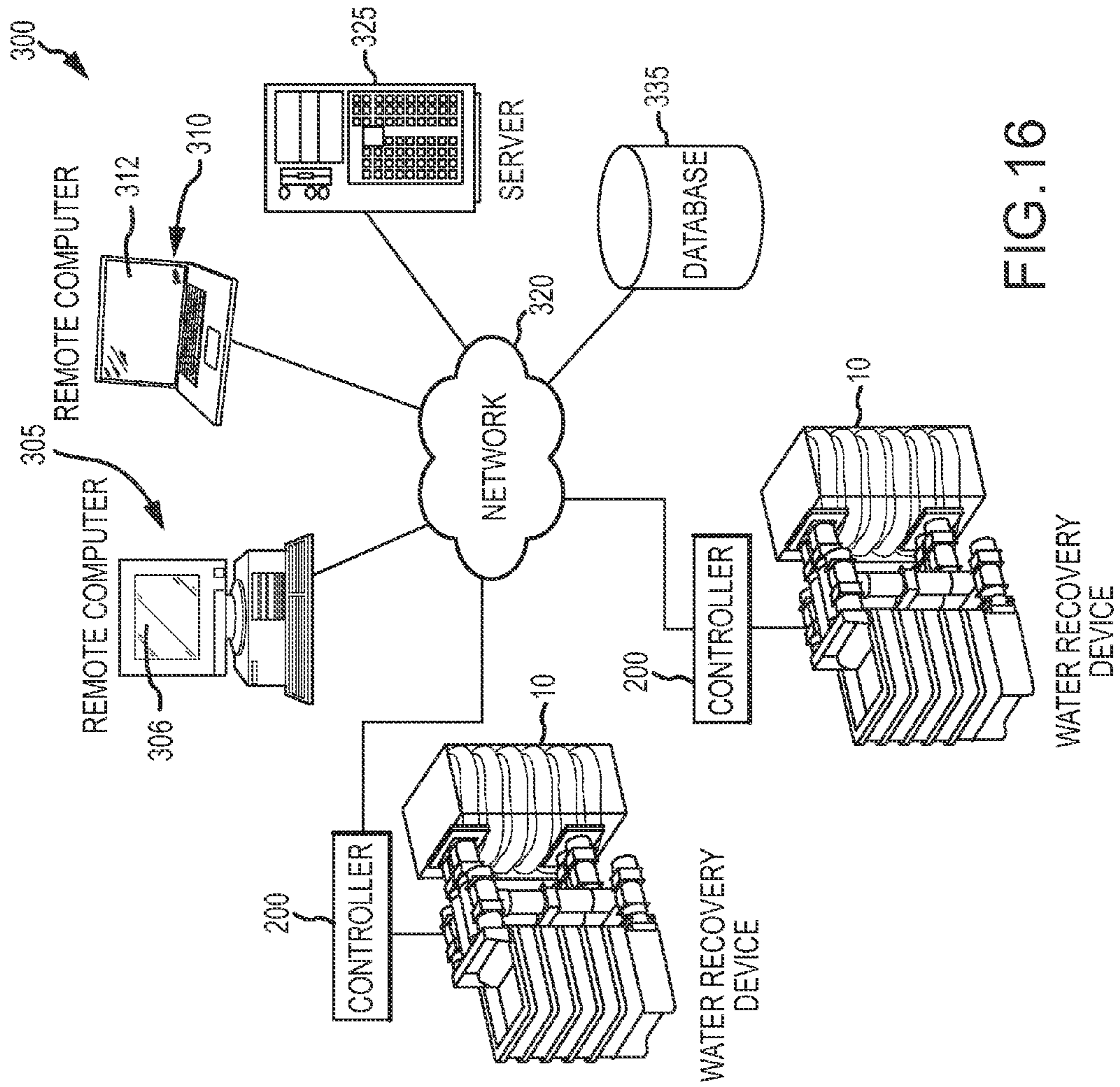

FIG. 16

1

**APPARATUS FOR WATER RECOVERY  
INCLUDING STACKABLE DESICCANT  
TRAYS**

CROSS REFERENCE TO RELATED  
APPLICATION

The present application claims the benefits of and priority, under 35 U.S.C. §119(e), to U.S. Provisional Application Ser. No. 61/655,316, filed Jun. 4, 2012, entitled "WATER RECOVERY SYSTEM AND METHOD," herein incorporated by reference in its entirety for all purposes.

FIELD OF THE INVENTION

The invention relates to a water recovery system and method of recovering water from ambient air. More particularly, the invention relates to an apparatus/device and method using a desiccant solution to extract water from the air, and then separating the water from the desiccant. The recovered water may be treated to obtain potable water. A byproduct of the system and method is a stream of dehumidified air that may be used for conditioning an interior airspace within a man-made structure.

BACKGROUND OF THE INVENTION

Potable water is often difficult to obtain in many locations throughout the world. In arid climates, there is simply a shortage of water and if water is available, it may difficult to make the water potable water without extensive water treatment resources. Even in wet climates, potable water may be in short supply because of the lack of treatment equipment. Unfortunate events such as war or general political conflict within a country often results in diminished infrastructure that would normally have the capability to provide potable water.

There are a number of known solutions for obtaining potable water by removing water vapor from the ambient air. One known method includes passing an airstream over a cool surface to condense the water vapor. This technique is well known, for example, in heating, ventilating, and air conditioning units (HVAC). In these types of systems, the condensed water however is usually considered as waste material, and is disposed of.

The use of solid and liquid desiccants is also known for extracting water from air. In a closed loop process, ambient air is passed through a chamber containing a desiccant soaked media. As the air passes in contact with the media, moisture from the air stream is removed by absorption into the desiccant. Heat is then applied to the desiccant media to vaporize the captured moisture. The water vapor is transported away from the chamber, and then condensed and collected. The desiccant is therefore re-concentrated and can be reused in a next water recovery effort.

Water recovery systems include the use of both solid and liquid desiccants. In liquid desiccant systems, one goal is to increase the exposed surface area of the desiccants to the air stream in order to maximize water vapor removal. One method of achieving this is to spray the liquid desiccant in a mist onto the media. However, a misting device adds to the complexity and cost of the system. Systems with solid forms of desiccants may provide a more compact construction. However, solid desiccants have relatively small exposed surface areas thereby limiting the capability to remove water vapor from a passing air stream.

2

One example of a reference that discloses the use of a liquid desiccant for recovering water from an airstream is the U.S. Patent Application Publication No. 2011/0232485. The reference provides a composite desiccant material formed by a porous polyvinyl alcohol (PVA) foam or non-woven sheets of fiber soaked in a solution of a hygroscopic desiccant such as calcium chloride (CaCl). The desiccant is held in pores of the fiber material ranging in size from 50 microns to 1000 microns. The fiber material is provided in sheets arranged in a stack in a multi-chamber system. During an absorption phase, atmospheric or ambient air flows through the chamber. The water vapor is removed through contact with the desiccant, and is held in the fiber material. In a water recovery phase, energy is added to the chamber in the form of heat in order to release the water from the desiccant by evaporation. Fans circulate air through the chamber, and eventually into a water recovery chamber within a condensing area. Water is recovered in the condensing area, and the dried or water lean airstream leaving the chamber may be used to condition a man-made structure. As also set forth in this reference, a control system can be used to operate fans within the water recovery system when conditions of humidity and the remaining capacity of the desiccant stack are conducive to an efficient charging operation to remove water from the ambient air. The control system may also initiate a regeneration cycle when the availability of low grade heat energy and the degree of saturation of the desiccant are conducive to removing water from the desiccant, that is, when the degree of moisture in the chamber is high enough relative to the temperature of an available cold source for an efficient condensing operation. U.S. Patent Application Publication No. 2011/0232485 is herein incorporated by reference in its entirety for all purposes.

Another example of a patent reference that discloses a method and device for recovering water from ambient air is the U.S. Pat. No. 6,156,102. Specifically, this reference discloses separating water from air by the use of a liquid desiccant to withdraw water from air, treatment of the liquid desiccant to produce water, and regenerating the desiccant for subsequent use. In one preferred embodiment, the method disclosed includes providing a hygroscopic solution comprising a solute in an initial concentration; contacting the hygroscopic solution with ambient air containing water to obtain a water rich hygroscopic solution having a concentration of solute less than the initial concentration and a water lean airstream; separating the water lean airstream from the water rich hygroscopic solution; releasing the water lean airstream to the atmosphere; and treating the water rich hygroscopic solution to obtain water and to return the hygroscopic solution to its original state for re-use. U.S. Pat. No. 6,156,102 is herein incorporated by reference in its entirety for all purposes.

As described in the U.S. Pat. No. 6,156,102, the effectiveness of liquid desiccants can be expressed in terms of both their "drying efficiency" and "drying capacity". Drying efficiency is the ratio of total water exposed to the hygroscopic solution as compared to the amount of water removed. The drying capacity is the quantity of water that a unit mass of desiccant can extract from the air. The drying efficiency and drying capacity of a hygroscopic solution is in part dependent upon the pressure of the water vapor in the air and on the concentration of the solute. In general, a hygroscopic solution having a high concentration of solute and thus a low partial pressure of water vapor in the solute, more quickly absorbs water from air having a higher partial pressure of water vapor. Accordingly, the hygroscopic solution has an initial drying efficiency that is relatively high. As water continues to be

absorbed during a water recovery process, the partial pressure of the water vapor in the solution increases and the rate of water absorption slows down. Eventually, the hygroscopic solution and the air may reach equilibrium, and no more water will be absorbed by the hygroscopic solution. In a desiccant regenerative process for the hygroscopic solution, the collected water in the hygroscopic solution must be removed. U.S. Pat. No. 6,156,102 is herein incorporated by reference in its entirety for all purposes.

While the prior art may be adequate for its intended purposes, there is still a need for a water recovery system and method that takes advantage of a modular construction in order to provide an integral capability to control parameters for efficient recovery of water from an ambient airstream. There is also a need to provide a construction that is easily adaptable to maximize water recovery for a specific application or situation. There is also a need to provide a water recovery system and method in which pre-established logic can be used to control the a water recovery device based upon known environmental factors and taking into consideration the necessary amount of water to be produced. There is yet further a need to provide a device and method that requires a minimum amount of energy for operation, and is conducive to accepting forms of waste heat for operation. There is also a need to provide a water recovery device and method that is reliable, simple to operate, and requires minimum intervention for daily operations. There is also a need to provide a water recovery device and method that is easy to transport, deploy and commission. There is also a need to provide a water recovery device in which monitoring of the concentration of the liquid desiccant solution is achieved automatically, in order to timely and efficiently recover water once the liquid desiccant solution has reached its water saturation limit. During the regenerative phase of a desiccant solution, it is preferable that the concentration of the desiccant does not become too high, which otherwise could result in crystallization or solidification of the liquid desiccant resulting in a reduced efficiency of the device until the desiccant chemical can be placed back into its optimal concentration with water.

#### SUMMARY OF THE INVENTION

The present invention includes a system and method for recovering water from an ambient airstream. Additionally, the invention achieves dehumidification of the airstream by removal of the water. The device is characterized by a group or stack of trays that hold an amount of liquid desiccant in each tray. A foam media absorbs or wicks the desiccant to increase the exposed surface area between the desiccant and the airstream that is passed through an enclosed chamber that holds the desiccant trays. A number of fans and dampers or valves are used to control the airflow through the chamber.

Operation of the device includes two cycles. The first cycle is a charge cycle in which ambient air is passed through the chamber, across the desiccant stack, and back to the environment. The desiccant causes water vapor in the airstream to be taken up and held in a foam media material that holds the desiccant. In a preferred embodiment, the desiccant is a liquid solution of CaCl and water that is impregnated into the foam media. The foam media may include a thin sheet of PVA that is arranged in an accordion folded manner to increase the surface area of the sheet that is exposed to the airstream. Once the desiccant media has absorbed a sufficient amount of water from the airstream, an extraction cycle is initiated to recover water from the desiccant solution. In this cycle, the chamber is isolated from the ambient air, and energy is added to the chamber in order to vaporize the water from the desiccant

solution. In addition to heat energy, the interior pressure of the chamber may be reduced to lower the evaporation temperature required to vaporize the water. For example, a fan can be used to remove an amount of air within the chamber, and then the chamber can be sealed to maintain the lower pressure state. One or more fans circulate the air within the chamber across the desiccant media to increase the rate of evaporation. When the internal temperature of the chamber exceeds a dew point temperature, relative to the external ambient conditions, a condensing circuit is enabled to condense the water vapor from the internal chamber air. The extraction cycle may also be referred to as a regeneration cycle in which the removal of water from the desiccant solution regenerates the desiccant placing it in a condition for re-use in which the concentration of the desiccant is returned to an optimal percentage.

Heat energy may be added to the chamber through a water or glycol-based heat exchanger. There are several possible sources of heat energy that can be used to include solar collectors, photovoltaic cells, waste heat from nearby industrial sources, electrical heaters, and gas heaters, among others.

The condensed water is captured, and may be further treated in order to make potable water. For example, the recovered water may be filtered, exposed to an ultra violet light source, mineralized, chlorinated, or may be otherwise treated to make the water safe for consumption.

A controller is used to integrate and manage all system functions and input variables to achieve a high efficiency of operational energy use for water output. The controller uses sensor inputs to estimate the amount of water in the system, the power used, the power stored, and the relevant external and internal environmental conditions such as temperature, pressure, humidity, sunlight/darkness. During the extraction cycle the controller is used to control heat energy added to the chamber and to also control the condensing rate to therefore sustain continuous operation for recovering water from a previous charge cycle. The controller may take advantage of sensor inputs and software that incorporates a number of algorithms to maximize efficiency of operation. For example, the algorithms may synthesize these inputs to control heat energy added to the chamber in a manner that minimizes energy usage from heat delivery systems and from fans and other internal components. During the charging cycle, similar inputs and algorithms can be used to control power consumption of fans and other internal components and to ensure a maximum water uptake.

For both system cycles, the algorithms may define optimal operating conditions for a known geographical area and a known calendar date which comprises historical data regarding average temperature, humidity, and sunlight/darkness conditions. From these algorithms, a baseline operating sequence can be established, and then modified by actual environmental conditions at the time. The controller receives multiple inputs that measure temperature, humidity, and pressure of the device during operation. Consequently, the controller manipulates outputs to efficiently operate the device by controlling outputs such as fans, dampers, and heat energy added to the device. During an extraction or regeneration cycle, the controller monitors the amount of water removed from the chamber to ensure that too much water is not removed that could result in a high desiccant concentration and crystallization of the desiccant.

In another aspect of control, the invention may include a system in which one or more devices may communicate with remote computing devices within a communications network. These remote computing devices can be used to assist in control of the device(s) and to gather data from the devices

or to send updated commands for device operation. Accordingly each controller may further include a wireless transmission and receiving capability. In this regard, a system of the invention may therefore also include multiple devices, each of the devices having a wireless communication capability.

In another aspect of control, the invention may include "location based" capabilities in which Global Positioning System (GPS), magnetometer or other location based subsystems are used to identify location and orientation of the installed system. This information can be used to further exploit data about geographical and/or weather conditions to enable better system efficiencies. For example, knowledge of orientation and duration of sunlight, directions of prevailing winds, etc may be used to obtain better efficiencies for solar energy extraction and minimized fan power needs, respectively.

In another feature of the invention, the device has a modular construction in which the desiccant trays can be arranged in a desired configuration. For example, the trays can be stacked vertically upon one another in a single column configuration. In another configuration, the trays can be stacked vertically upon one another in multiple columns that are connected to one another, thereby forming a combination of horizontal rows and vertical columns. In yet another configuration, the trays can be stacked both vertically and connected laterally/horizontally in an irregular configuration. This irregular arrangement is advantageous, for example, if the device needed to be incorporated within a space that itself had an irregular shaped opening, or the surface upon which the device is mounted is not flat.

Additionally, the airflow pattern through the device can be modified with selective configuring of removable panels defining the separation between horizontally adjacent panels. Further, adjustable sized openings can be provided in each of the sidewalls of the trays so that a user can specifically configure the desired airflow pattern.

In another feature of the invention, the particular pattern/configuration of trays chosen for installation can be referred to as the desiccant tray array for the installation. The arrays can include vertical, horizontal, and irregular array combinations.

Because of the vertical and horizontal array combinations that can be achieved with the device, a user has a nearly limitless number of configurations options available, which enables the user to optimize the desired water producing capability of the device by varying the number of trays incorporated and the particular configuration of the trays in an array.

Further, the modular construction takes advantage of uniform sized tubing and couplers/flanges that allow for easy assembly and disassembly of the device. Further, the fans and dampers may also be of uniform construction, therefore allowing interchangeability among components, for ease of assembly/disassembly.

In yet another feature of the invention, the modular construction allows for a number of different options for adding heat energy to the device. Each of the desiccant trays may be configured to connect to a heating assembly. The heating assembly, in a preferred embodiment, may include a heating coil placed in close proximity to heat distribution fins. The heating assembly itself may be configured as a stackable tray unit.

In yet another feature of the invention, the airflow through the chamber of the device may be dynamically configured to optimize desired water extraction. For example, each of the desiccant trays may include airflow openings on one or more sides of the trays that control the direction of airflow through

the chamber. In one example, the airflow may take a torturous path through the chamber in which there is a single or serial path through each of the desiccant trays.

In another example, the airflow may take a parallel flow pattern through the chamber in which there may be multiple paths available for airflow through the chamber. Accordingly, airflow through the chamber may be configured to best match fan capabilities in moving an optimum flow of air through the device.

In yet another feature of the invention, the dried airstream that is produced when leaving the device may be used for a number of applications, such as providing a humidity controlled airstream to condition an airspace within a building or other man made structure. Particularly in hot, humid climates, the dried airstream produced can greatly improve working and living conditions within habitable spaces.

Although calcium chloride is disclosed for use as a preferred chemical hygroscopic desiccant, it should be understood that there are a number of other hygroscopic desiccants that could be used. For example, lithium bromide, magnesium chloride, and lithium chloride are known as effective hygroscopic desiccants. However, one advantage of calcium chloride is that it is a non-toxic chemical, and is therefore safe to use.

Although the invention is described with respect to a preferred embodiment in which the desiccant is employed through a liquid solution, it is also contemplated that the desiccant can be initially employed as a solid. For example, the desiccant media can be pre-soaked in a solution of the CaCl or other hygroscopic desiccant, and then the desiccant media is dried prior to use. The pre-soaking of the desiccant media can effectively disperse the desiccant chemical within the desiccant media. Another method in which to employ a solid desiccant is to spray the desiccant media with a desiccant solution, and allowing the desiccant media to dry prior to use. Yet another method to employ a solid desiccant in the desiccant media is to directly apply a solid form of the desiccant to the desiccant media, such as a desiccant chemical in a powdered form in which the powder then adheres to the desiccant media.

It should also be understood that reference to a "liquid desiccant", a "liquid desiccant solution", or variations thereof, refers generally to the use of a desiccant chemical that is initially deployed with a liquid component to form the solution. However, the desiccant chemical becomes dried within the media material during an extraction cycle, and therefore, the desiccant may become a semi-solid/gel or a solid. Then, during a subsequent charge cycle, the desiccant chemical is re-wetted, and may be returned to solution; to include an over saturated solution that may drip back into the desiccant tray.

In one aspect of the invention, it can be considered a system for recovering water from ambient air. In another aspect of the invention, it can be considered an apparatus for recovering water from ambient air with options for manual control, automatic control, or combinations thereof. In another aspect of the invention, it can be considered a system for dehumidifying ambient air for purposes of providing conditioned air for an interior space of a man made structure.

In another aspect of the invention, it may include various sub-combinations of the system and device. These sub-combinations may include (1) the desiccant stack, (2) the heat exchanger with the desiccant stack, (3) the desiccant stack and the condenser, (4) the desiccant stack, heat exchanger, and condenser, and (5) and the desiccant stack, heat exchanger, and condenser further in combination with a controller. Each of these sub-combinations has utility.

Other aspects of the invention include a construction for a desiccant cartridge, a method of selectively controlling air flow through a chamber for a water recovery device, a modular construction for a water recovery device utilizing easily assembled components, a method for controlling a charging cycle of a water recovery apparatus including the use of algorithms to optimize operation, a method for controlling an extraction cycle of a water recovery apparatus including the use of algorithms to optimize operation, a method of operating a water recovery device including the use of algorithms to minimize energy usage, a method of operating a water recovery device including the use of algorithms to provide an even and continuous operation of a water recovery device, and a method of controlling operation of a water recovery device incorporating a plurality of control inputs including various sensors, weigh scales, and flow meters.

Yet further aspects of the invention include a water recovery device utilizing multiple energy sources to power an extraction cycle, a method of determining optimal formulations for a liquid desiccant solution used within a water recovery device, a construction for a desiccant media including a formulation for a liquid desiccant solution, a water recovery device including configurable desiccant media cartridges, a method for selective and dynamic control of a liquid desiccant solution used within a water recovery device, a water recovery device including insulating and sealing components that effectively isolate airflow through the device and otherwise provide optimal temperature and pressure conditions within a chamber of the device, and a method for determining an optimal initial desiccant formulation of a water recovery device considering relevant geographical data corresponding to the geographical location where the device is to be installed.

Considering the above features and advantages of the invention, the invention can be considered, in one aspect, a water recovery device comprising: (i) a desiccant stack including a chamber defining an airflow path therein, the stack including a plurality of desiccant trays, each tray including a desiccant media cartridge and an amount of liquid desiccant placed within the tray and being absorbed by a media material of the media cartridge; (ii) the plurality of desiccant trays being configured in an array comprising at least one column of vertically stacked desiccant trays, or a row of laterally adjacent trays. (iii) a condenser communicating with the desiccant stack; (iv) a heat exchanger communicating with the desiccant stack for providing heat to the desiccant stack; and (v) wherein the water recovery device is operated in a charge cycle for circulating ambient air through the chamber to remove water vapor by the liquid desiccant and retaining water vapor in the chamber, the device being further operated in an extraction cycle to remove the retained water vapor within the chamber, the condenser providing a cooling source to condense the water vapor and thereby producing an amount of water condensate.

The invention can be considered, in another aspect, a water recovery system comprising: (a) water recovery device including: (1) a desiccant stack including a chamber defining an airflow path therein, the stack including a plurality of desiccant trays, each tray including a desiccant media cartridge and an amount of liquid desiccant placed within the tray and being absorbed by a media material of the media cartridge; (2) the plurality of desiccant trays being configured in an array comprising at least one column of vertically stacked desiccant trays, or a row of laterally adjacent trays; (3) a condenser communicating with the desiccant stack; (4) a heat exchanger communicating with the desiccant stack for providing heat to the desiccant stack; (5) wherein the water

recovery device is operated in a charge cycle for circulating ambient air through the chamber to remove water vapor by the liquid desiccant and retaining water vapor in the chamber, the device being further operated in an extraction cycle to remove the retained water vapor within the chamber, the condenser providing a cooling source to condense the water vapor and thereby producing an amount of water condensate; (b) a controller incorporated in the device for controlling functioning of the device to include the charge cycle and the extraction cycle, the device further including a plurality of sensors as inputs to the controller, and a plurality of valves and fans as outputs of the controller, the valves and fans being located within air transport lines of the device; (c) said water recovery device further including a communications node incorporated within a communications system enabling the water recovery device to communicate within the communications system.

In yet another aspect of the invention, it may be considered as a method of configuring an array of desiccant trays for use in a water recovery device, said method comprising: (i) providing a plurality of desiccant trays; (ii) determining installation specific requirements for the water recovery device; and (iii) configuring the desiccant trays in an array having a plurality of the desiccant trays arranged in a vertical column or a horizontal row, each column and row having a plurality of desiccant trays taking into consideration the requirements.

The preceding is a simplified summary of the disclosure to provide an understanding of some aspects of the invention. This summary is neither an extensive nor exhaustive overview of the disclosure and its various aspects, embodiments, and/or configurations. It is intended neither to identify key or critical elements of the disclosure nor to delineate the scope of the disclosure but to present selected concepts of the disclosure in a simplified form as an introduction to the more detailed description presented below. As will be appreciated, other aspects, embodiments, and/or configurations of the disclosure are possible utilizing, alone or in combination, one or more of the features set forth above or described in detail below. Therefore, other features and advantages of the present disclosure will become apparent from a review of the following detailed description, taken in conjunction with the drawings.

#### BRIEF DESCRIPTION OF THE DRAWINGS

FIG. 1 is a schematic diagram of the device of the invention in one preferred embodiment;

FIG. 2 is an exploded perspective view of a desiccant tray and desiccant media cartridge;

FIG. 3 is another perspective view of the desiccant tray with the desiccant media cartridge mounted within the tray, and also illustrating a removable side wall or panel that enables the tray to be connected horizontally to another tray;

FIG. 4 is a vertical section of the desiccant tray of FIG. 2 showing details of the arrangement of the desiccant media cartridge and an amount of desiccant solution within the tray;

FIG. 5 is an exploded perspective view of a heat exchanger assembly;

FIG. 6 is a perspective of the assembled heat exchanger assembly of FIG. 5;

FIG. 7 is a vertical section of a desiccant tray mounted over a heat exchanger assembly, illustrating the relationship between heat distribution elements of the heat exchanger and the desiccant tray;

FIG. 8 is a fragmentary perspective of the device in a preferred embodiment;

FIG. 9A is a perspective view of a preferred embodiment of a desiccant stack including a plurality of vertically stacked desiccant trays arranged in a single column configuration or array, a heat exchanger assembly located beneath the desiccant trays, and a stack exhaust manifold for directing exhaust air from the desiccant stack;

FIG. 9B is a perspective view of an alternate preferred embodiment of a desiccant stack including a plurality of vertically stacked desiccant trays arranged in two side-by-side columns, in which one or more of the trays between the respective columns may be connected horizontally for creation of a modified airflow pattern through the device;

FIG. 9C is a perspective view of yet another preferred embodiment of a desiccant stack including a plurality of vertically stacked desiccant trays arranged in three side-by-side columns, in which one of the columns has a fewer number of trays, thereby resulting in an irregular shaped tray configuration;

FIG. 9D is an enlarged fragmentary plan view of two horizontally adjacent trays illustrating removable sidewalls or panels, and connection details allowing trays to be connected horizontally to one another;

FIG. 10 is a vertical section of FIG. 9 illustrating the relationship between the desiccant trays and the heat exchanger assembly in the single column configuration;

FIG. 11 is a schematic diagram of a desiccant stack, and one configuration for an airflow path through the chamber, referred to herein as a parallel flow path;

FIG. 12 is another schematic diagram of a desiccant stack, and another configuration for an airflow path through the chamber, referred to herein as a serial flow path;

FIG. 13 is an exploded perspective of components of the device including a fan and damper/valve combination;

FIG. 14 is an assembled perspective of the components of FIG. 13;

FIG. 15 is a schematic diagram of components of a controller that may be used in conjunction with control of the device; and

FIG. 16 is a schematic diagram of a communication system, including a plurality of devices with integral controllers operating within a communications network in which one or all of the devices may communicate with other communication nodes of the network, to include download and upload of data and commands.

#### DETAILED DESCRIPTION OF THE DRAWINGS

Referring to FIG. 1, a schematic diagram is shown for purposes of illustrating the major functional components of a device of the system. Specifically, the device 10 includes a housing 12 that defines therein an interior space or chamber for receiving a flow of air to remove water vapor from the airstream. The chamber is more specifically defined as including a desiccant stack 14 including a plurality of desiccant trays 74 (see FIG. 2) that each holds a desiccant media material.

Each of the trays 74 have a quantity of a liquid desiccant solution placed in contact with the desiccant media material that wicks or absorbs the solution, as set forth further below with respect to the description of the FIGS. 2-4. The device 10 further includes one or more heat exchanger assemblies 16 for providing heat to the chamber. A weigh scale 18 is used to monitor the mass of water vapor that is collected from the airstream during a charge cycle, as well as the mass of water vapor that is removed from the liquid desiccant solution during an extraction cycle.

An ambient or environmental or ambient air intake line 20 provides an entry point for the ambient air to enter the chamber area. The ambient air entering the chamber follows a flow path 22 through the heat exchanger assembly 16 and the desiccant stack 14. In the schematic diagram of FIG. 1, the flow path 22 illustrates a winding or torturous path, which is explained in more detail below with respect to configurable flow paths shown in the FIGS. 11 and 12. An exhaust line 24 returns the airstream that has traveled through the chamber back to the atmosphere. Alternatively, the exhaust line 24 may communicate with ductwork of a man made structure (not shown) to provide a conditioned airstream for the structure.

The airstream through the chamber may take one of several paths, depending upon the particular cycle in which the device is operating at the time. In the case of a charge cycle, the airstream is exhausted to the atmosphere or manmade structure through the exhaust line 24. During an extraction cycle, air within the chamber exits the chamber through the condenser inlet line 26 that interconnects the chamber with the condenser 28. Also during an extraction cycle, prior to when air within the chamber reaches the desired saturated state ready for condensing, air is re-circulated through the chamber by re-circulating line 72, as also discussed below.

FIG. 1 also schematically illustrates a cooling coil 30 that is used to condense the moist airstream for extraction of water vapor from the airstream. An ambient air cooling line 32 is also illustrated within the condenser 28. During the extraction cycle, ambient air is used as the cooling source for condensing the warmer, moist airstream that has entered the cooling coil 30. A water collection container 34 is provided for collecting the condensed water by water line 36 that interconnects the condenser 28 to the container 34. A weigh scale 38 may also be used to monitor the amount of water extracted. In conjunction with scale 18, the scale 38 provides control inputs for monitoring water recovery.

The heat exchanger assembly 16 includes a heat source 40. The heat source 40 in the schematic of FIG. 1 is shown as a solar collector or photovoltaic cell; however the heat source could be many other sources such as an electric or gas heater, or available waste heat sources. For example, the heat source could include waste heat from an industrial process, or waste heat captured from the exhaust manifold or engine of a vehicle. A closed loop heating line 44 is used to re-circulate an amount of heating fluid. As shown, the heating line 44 traverses through the chamber and in close proximity with the desiccant stack 14. The heating fluid 42 may be a conventional heating fluid such as water or glycol. A heating fluid container 45 is provided to store the heating fluid. A fluid pump 70 is used to re-circulate the heating fluid 42 through the heating line 44. Although FIG. 1 illustrates the heat source 40 and container 45 as separated from the other components of the heat exchanger assembly 16 within the chamber, it shall be understood that the heat exchanger assembly 16 could be housed in a number of different configurations to accommodate the particular application which the device is being used.

A controller 84 may be used to provide automatic control of the operation of the device. The controller 84 may take the form of known industrial controllers that accommodate control inputs and outputs, and a processor with integral software or firmware. With respect to inputs, the device may be monitored by a number of temperature sensing devices 46, such as thermocouples or RTDs. In FIG. 1, there are a number of temperature sensors shown at various locations throughout the device. Within the heat exchanger assembly, a number of temperature sensing devices 46 are also shown to include sensors located within the heat exchanger, and within the heating line at the entrance and exit from the heat source 40.

## 11

A number of temperature sensors are also illustrated within the desiccant stack 14, as well as within the condenser 28.

In addition to temperature control, the FIG. 1 also illustrates a liquid flow sensor 48 that measures the flow rate of the heating fluid 42 through the heating line 44. An airflow sensor 49 may also be incorporated within the exhaust line 24 to monitor the flow rate of air through the chamber. Further, a number of relative humidity sensors 50 may be incorporated within the device to measure relative humidity of the airstream. As shown in FIG. 1, relative humidity sensors 50 may be co-located with temperature sensors 46 at the exhaust line 24, at the condenser return line 73, and at other selected locations in which it may be desirable to monitor the relative humidity.

With respect to controlling airflow through the device, a number of fans may be used to precisely control airflow. Referring again to the FIG. 1, the fans may include an intake fan 52 communicating with the air intake line 20, an exhaust fan 56 that communicates with the exhaust line 24, a condenser fan 68 that introduces air into the condenser 28 along condenser inlet line 26, a re-circulating fan 64 that re-circulates air through the chamber through re-circulating line 72, and an ambient air cooling fan 69 that introduces ambient air into the condenser 28. Control of air flow through the device is also achieved through a number of dampers or valves. Again referring to the FIG. 1, the group of valves may include an air intake valve 54 mounted in the air intake line 20, an exhaust valve 58 that is mounted in the air exhaust line 24, a condenser inlet valve 62 that is mounted in the condenser inlet line 26, and a re-circulating valve 66 that is mounted in the condenser return line 73.

Referring now to FIGS. 2-4, a desiccant tray 74 is illustrated in accordance with a preferred embodiment. The tray 74 includes sidewalls 90, and a base 96. One or more of the sidewalls 90 may include rod receiving channels 94 that receive rods or dowels (not shown) that stabilize the connection between stacked trays 74. At least one pair of opposing sidewalls 90 may include an interior flange 92 for mounting a sealing gasket 75 (see FIG. 8). Preferably, there is a sealing gasket placed between each stacked tray 74 to thereby limit airflow loss through the chamber. The base 96 holds an amount of liquid desiccant solution 110 (FIG. 4). The base 96 includes base sidewalls 98, and one or more of the sidewalls 98 may include a plurality of airflow circulation slots or openings 100. As shown, these openings 100 are disposed at the upper portion of base sidewalls 98, above the liquid line 112 of the liquid desiccant solution 110, and below the top edge of the sidewalls 90. FIGS. 2-4 also illustrate a desiccant media cartridge 82 that is placed within the desiccant tray 74, as best illustrated in the FIG. 3. The media cartridge 82 is shown as a rectangular shaped element that fits within the confines of base sidewalls 98. The media cartridge 82 includes a media frame 102 that holds media material 120 in an accordion folded configuration. The media frame 102 may also include one or more frame panels 104 that can be used to direct airflow through the chamber by preventing air from passing through the panels 104. In the FIG. 2, it is intended to show that the two end walls of the media frame 102 include media frame panels 104, while the opposing sidewalls of the media frame 102 remains open thereby allowing airflow horizontally through the media cartridge 82. In order to stabilize the open sides of the frame 102, the frame may further include screen supports 106 comprising a plurality of wire elements as shown.

Referring to FIG. 4, the media material 120 is illustrated in the form of a thin sheet that is held in the accordion folded configuration to thereby maximize the exposed surface area

## 12

of the media material to air passing through the chamber. As shown, the desiccant solution 110 fills a portion of the base 96, and the lower end of the media material 120 is submerged in the fluid solution 110. As mentioned, one example of an acceptable media material may include a thin sheet of PVA foam, an absorbent foam that readily wicks the desiccant solution 110. In order to maintain the media material in the accordion folded configuration with uniform gaps or spaces between the folds of material, an internal wire support 122 may be used for stabilizing the media material. When the media material 120 absorbs or wicks the desiccant solution 110, the material serves to evenly distribute the desiccant solution in large surface area within a confined space. Accordingly, the media material 120 and the desiccant solution 110 provide a hygroscopic feature to effectively remove water vapor from a passing airstream. As shown in the FIG. 4, the media material 120 is preferably oriented in a parallel relationship with the flow of air, thereby enabling air to pass through the gaps between the folds of the media material. In this orientation, the airstream maintains significant contact with the exposed surfaces of the media material. As air continues to flow through a media cartridge 82, the amount of water vapor retained in the media material increases. It is possible for the amount of retained water vapor to exceed the liquid holding capacity of the media material, resulting in dripping of the desiccant solution into the pool of desiccant fluid 110. As discussed further below, it is advantageous to begin an extraction cycle prior to complete saturation of the media material.

The thickness of the media material, as well as the configuration of the media material in terms of the size of the gaps between folds of the media material can be adjusted to meet the desired water recovery needs for a particular use. Thinner sheets of material with larger gaps between folds of the material allows for better airflow through the chamber, thereby reducing the airflow pressure drop through the chamber. However, this configuration of the media material limits the amount of water vapor that can be removed from the airflow. Reducing the size of the gaps between the folds of the media material and increasing the width of the media material results in increased capability to remove water from the airflow, but with the disadvantage of increased pressure drop through the chamber therefore requiring greater fan capacity in moving air through the chamber. It is therefore contemplated to adjust the particular configuration of the media material so that water recovery is achieved to meet the needs of the particular use of the device without excessive air pressure drop through the device that may exceed the capacity of the fans.

The desiccant solution 110 is placed in each of the trays 74. This may be done manually at the start of operation of the device. As the device continues to operate, it may be necessary to replenish the desiccant solution. For example, some portions of the desiccant media that absorb the desiccant solution may become dried and crystallized, thereby preventing reactivation of the desiccant chemical without cleaning and re-soaking the desiccant media. In lieu of manually replacing the desiccant solution 110, it is also contemplated that the desiccant solution 110 may be automatically replenished. A desiccant solution reservoir (not shown), and a water reservoir (not shown) may have fluid conveying lines that connect to each or selected ones of the trays 74. Each of the trays may also include a liquid level sensor (not shown) and/or a desiccant concentration sensor (not shown) to sense the concentration of the chemical desiccant. Chemical concentration sensors are devices that measure the electrical potential of a solution, and changes in the electrical potential

## 13

correspond to known changes in the concentration of a chemical within the solution. Based on inputs from these sensors, replenishment valves (not shown) mounted in the fluid conveying lines could be selectively opened to release a designated amount of water and/or desiccant solution in order to replenish the desiccant solution in the trays. In many cases, it may only be necessary to add water back to the desiccant solution in order to place it at the optimum desiccant concentration.

Referring now to FIGS. 5 and 6, components are illustrated for the heat exchanger assembly 16 that reside below a desiccant stack 14. As shown, the assembly includes a housing 76, including sidewalls 130 and a bottom wall or base 128. One side of the housing 76 includes a tubing manifold 132 with openings to receive corresponding tubing sections 134. Extending upward from the base 128 is a plurality of baffles 140 that are used to support the heating distribution element 78. As shown, the heating distributional element 78 is also an accordion folded element that fits between the sidewalls 130, and is disposed above the heating line 44. The heating line 44 is configured in a winding path to thereby more evenly transfer heat to the heat distribution element 78. The heating line 44 passes through one of the sidewalls 130 as shown in FIG. 6, and communicates with the heat source 40 and container 45 (FIG. 1). Optionally, a wire support element 136 may be disposed within the housing 76 in order to maintain the heating element 78 in its accordion folded configuration. The heat distribution element 78 may be made from aluminum or another type of corrosive resistant conductor. The housing 76 may also include rod receiving channels 138 that align with channels 98 of the desiccant trays 74 to receive stabilizing rods (not shown) that help to hold the desiccant stack and heat exchanger assembly in a stabilized vertical orientation.

Referring to FIG. 7, the arrangement of a desiccant tray 74 is shown with respect to the heat exchanger housing 76. As shown, the base or bottom portion of the desiccant tray 74 is located in close proximity to the upper surfaces the heat distribution element 78. This orientation may allow for most efficient heat transfer to the overlying tray 74. FIG. 7 also illustrates the available space for air entering the device in which the air first passes through the gaps between adjacent sections of the heat distribution element 78. The airstream is then directed upwards, through the openings 100 in the base sidewall 98 of the tray. Next, air is forced horizontally through the gaps in the media material 120 and substantially parallel with the orientation of the media material 120. The air then travels upward into the next desiccant tray 74. The path of airflow through this next desiccant tray is dictated by the orientation of the openings 100 in the base sidewalls 98 of the tray.

Referring to FIG. 8, a preferred embodiment is illustrated for the device 10 with respect to construction details for the desiccant stack 14, heat exchanger 16, and the group air conveying elements including fans, valves, conveying lines, and connectors. More specifically, the FIG. 8 illustrates a desiccant stack 14 arranged in a plurality of desiccant trays 74 stacked vertically upon one another over a single heat exchanger assembly 16. The most upper tray 74 is removed for illustration purposes to show a sealing gasket 75 that is placed between stacked trays. The most upper tray includes a top cap (not shown) that is sealed with respect to the sealing gasket 75. The stack exhaust manifold 80 is also shown in which airflow from the chamber is returned to the atmosphere through lines 24. As shown in this embodiment, instead of a single exhaust line 24, there is a pair of exhaust lines 24 arranged as the outside pair of conveying lines in the group of four adjacent lines. The embodiment of FIG. 8 is intended to

## 14

illustrate that some of the conveying elements may be provided in duplicate for better airflow control of the device. Accordingly, in addition to duplication of the exhaust lines 24 and associated fans and valves, the FIG. 8 also illustrates duplication of the condenser inlet line 26, re-circulating line 72, return line 73, and the associated valves and fans for these lines. FIG. 8 also shows an optional fan 75 associated with each return line 73 if additional force is required to remove the air from the condenser 28. In the event a particular installation of the device calls for the dual line configuration such as shown in this figure, it may also be advantageous to incorporate air distribution manifolds at the junctions between these lines and the condenser in order to simplify the connections between the lines and the condenser. Accordingly, the FIG. 8 also shows respective manifolds 81 and 83. In FIG. 8, the condenser 28 is shown in a schematic form only, and it shall be understood that the distal free ends of the lines 26 and 73 interconnect with the inlet and outlet of the condenser coil 30. If manifolds 81 and 83 are employed, these manifolds communicate with the inlet and outlet of the condenser coil 30, respectively. Because of the angle of view in FIG. 8, another inlet line 20 and associated conveying elements cannot be seen, but the FIG. 8 is intended also to represent that there can also be duplication of these elements. FIG. 8 does not illustrate all of the other components of the condenser as shown in FIG. 1, but it shall also be understood that the condenser includes these other elements. Additionally, it is contemplated that the condenser 28 could have more than one condenser coil 30. Thus, if a dual line configuration is used such as shown in FIG. 8, it is also contemplated that each of the line pairs 26 and 73 could be connected to separate coils 30.

In terms of the modular construction of the device, it is clear that the desiccant trays 74 may be conveniently stacked on top of one another in a space saving arrangement. Additionally, the location of the various fans and valves may be conveniently located adjacent the desiccant stack to maintain a relatively small device profile. The lines for conveying airflow may be a plurality of uniform tubing sections, and the tubing sections may connect to one another by a friction fit. Therefore, it is unnecessary to provide sealing gaskets between each and every tubing section. As discussed in more detail below with respect to the FIGS. 13 and 14, the modular construction of the invention further allows for friction fit attachments between the sections of tubing and the various valves and fans.

Referring to FIG. 9A, a desiccant stack 14 is illustrated in the same arrangement as shown in the FIG. 8, but with the various tubing sections, valves, and fans removed. This embodiment may be referred to as a single column configuration or array in which the desiccant trays are placed vertically on top of one another.

As shown in the FIGS. 9B and 9C, it is also contemplated that a desiccant stack could include combinations of both vertically and laterally/horizontally extending desiccant trays. Referring first to FIG. 9B, this embodiment illustrates two side-by-side columns of trays, in which one or more of the trays may be connected to one another horizontally, as described with respect to FIG. 9D below. In the embodiment of FIG. 9B, it is also shown that each of the columns has respective heat exchanger assemblies 16, stack exhaust manifold assemblies 80, and tubing manifolds 132. It is also contemplated that side-by-side columns of trays can also be equipped with a single heat exchanger assembly that spans continuously across the base of the device, in which the heating elements and other components of the heat exchanger may be expanded in size. It is also contemplated that the side-by-side columns of trays may be equipped with a single



stack exhaust manifold assembly which may also span continuously across the upper end of the device, as well as a single tubing manifold which would span continuously across the bottom edge of the device to accommodate the particular tubing connections for the installation. Although the FIG. 9B illustrates to side-by-side columns of trays, additional columns of trays may be added to provide a device with the necessary water recovery capabilities. One can appreciate that, because of the modular capabilities of the invention, there are almost a limitless number of ways in which the device can be configured.

Referring to FIG. 9C, this embodiment illustrates an example of how the device may be expanded horizontally with three side-by-side vertical columns. This embodiment also illustrates that one of the columns may have fewer trays that are vertically stacked, thereby resulting in a device which has an irregular shape. One or more of the trays may also be connected to one another, horizontally in order to provide a particular desired airflow pattern through the device. With respect to a horizontally extending group of desiccant trays 74, each of the trays, or a fewer selected ones of the trays may also include a tubing manifold 132 in lieu of solid sidewalls 90 and 98 enabling horizontally adjacent trays 74 to communicate with one another by tubing sections interconnecting the trays by their corresponding manifolds 132. Therefore, one can again appreciate the highly configurable nature of the device in terms of adjusting its shape and size for a particular use.

FIG. 9D is an enlarged fragmentary plan view of two horizontally adjacent desiccant trays 74 illustrating removable sidewalls or panels 95, and connection details allowing the trays to be connected horizontally to one another. More specifically, one of the trays 74 includes a connecting flange 91, while the adjacent tray 74 includes an opposing connecting extension 93. The connecting flange 91 has a channel 101 that receives the connecting extension 93 in a friction fit. Therefore, a horizontal connection may be facilitated between the two horizontally adjacent trays 74 without the requirement of an additional sealing gasket. As shown, each of the trays 74 also has respective sidewall track assemblies 97 in which the removable sidewalls or panels 95 are secured within their respective slots 99. Accordingly, when two horizontally adjacent trays 74 are connected to one another, the sidewalls/panels 95 can be removed enabling horizontal airflow between the two trays 74. This horizontal airflow capability is represented by the multi-directional arrow A.

It is also contemplated that the removable sidewalls or panels 95 may be adjusted in height to control airflow between the horizontally adjacent trays 75. For example, it may be desirable to have some horizontal airflow communication between the adjacent trays 75, but it may also be desired to have some restricted airflow between the trays. Accordingly, one or more of the panels 95 can have a selected height that is less than a full height as compared to the other side walls of the tray. Thus, this panel of a reduced height can be retained within its corresponding slot 99 to enable some airflow between the horizontally adjacent trays 74, but in a restricted manner.

Although FIG. 9D illustrates the combination of the connecting flange 91 and connecting extension 93, other connecting means can be provided to allow horizontal connection between horizontally adjacent trays 75. For example, other flange/connecting extension configurations can be provided in which a friction fit is used to connect the adjacent desiccant trays. It is preferable however, to select connection designs

that do not require sealing gaskets or other external sealing elements to effectively seal the surfaced joined between the adjacent trays.

Referring to FIG. 10, this vertical cross-sectional clearly illustrates the compact and orderly arrangement of the desiccant trays when placed in the vertical configuration of FIG. 9A. The capability to stack trays upon one another and to seal each of the trays to one another without requiring further modification to the trays makes the construction of the device user friendly to create an array of trays in the desired configuration.

For uses of the device with greater water recovery requirements, a larger number of trays can be used to increase water recovery, or uses of the device with lesser water recovery requirements may dictate a fewer number of trays be used. The requisite number of air conveying lines, fans, and valves can be added to a desiccant stack to ensure proper airflow through the device for purposes of both maintaining airflow through the device during a charging cycle, as well as airflow through the device during an extraction cycle.

Referring to FIGS. 11 and 12, in yet another aspect of the invention, it is contemplated that a user may dynamically configure the flow path of air through the device in order to maximize efficiency for the intended use of the device. In the example of FIG. 11, a parallel flow path is illustrated by the directional arrows in which each of the trays 74 have opposing base sidewalls 98 with openings 100, which therefore allows airflow to travel upwards in a vertical manner through the chamber and also horizontally through the media cartridges 82. The only blocked sidewall with no openings 100 is the solid sidewall 180 located above the heat exchanger assembly 16. This sidewall 180 ensures the air initially passes through the heat exchanger for purposes of heating the air, for example, during an extraction cycle. As shown in the FIG. 11 air may travel horizontally through either a first lower media cartridge, or the media cartridge in the second or next higher tray 74.

In the example of FIG. 12, the directional arrows show a torturous or serial flow path that is provided through the chamber of the device. Accordingly, alternating and opposite sidewalls of the stacked desiccant trays 74 include the solid sidewalls 180 without openings 100. One can appreciate the advantages of the dynamic and modular construction of the present invention in which the trays can be placed not only in various combinations of vertical and horizontal arrangements, but also each tray may be configured with either solid sidewalls 180 or sidewalls 98 with openings 100 in order to establish a desired airflow path through the chamber, and thereby maximizing airflow for the intended use of the device.

In the embodiments of FIGS. 9B and 9C, one can appreciate that a user can configure the airflow in a nearly limitless number of paths in which the removable panels 95 enable selective airflow between horizontally adjacent trays 74. For example, one portion of the device can incorporate a serial flow path, while another portion of the device may incorporate a parallel flow path, while yet another portion of the device may incorporate combinations of both serial and parallel flow paths. The highly configurable nature of the device enables a user to specifically select not only the particular capacity and shape of the device, but also the particular airflow pattern between discrete selected portions of the device.

In another preferred embodiment of the invention, it can be considered a method of configuring an array of desiccant trays for use in a water recovery device. Because of the modular capabilities of the device in which the desiccant trays can be selectively arranged, this method of the invention

provides numerous benefits to a user who is able to uniquely configure the device for a site specific installation.

In one step of the method of configuring an array, it includes determining installation specific requirements for the water recovery device. These requirements may include the water recovery output requirement in which the device must be configured with enough desiccant trays to produce a known volume of water needed over a period of time. Depending upon the climate where the device is to be installed, the user has to determine the number of desiccant trays employed to produce the given water requirement. Data can be developed to record the average amount of water produced by a tray in a climate having known parameters including average daily temperature, pressure, and humidity conditions. Based upon this baseline data, the user can select the number of trays necessary to fulfill the estimated water production requirement. Other site specific requirements may include size and mounting constraints in which the device must fit within a designated mounting profile and/or within a designated height profile. Additionally, an installation may require multiple devices to be installed, in which one or more of the devices must have an array selected to accommodate mounting or height constraints of the site. Another factor or constraint to be considered is the number of desiccant trays available for a specific installation. If the number of available trays is limited, then the user can also consider manipulating the airflow pattern through the device in order to maximize surface area contact between the desiccant media and the airflow through the device. In any event, airflow considerations are a factor to be considered when installing a device, even if there are no limitations on the number of desiccant trays available. Yet additional factors to consider for installation of the device include available condensation capabilities and heating capabilities. If either of these factors are a material constraint for the installation involved, the user has the capability to adjust deficiencies in these factors by adjusting the number of desiccant trays used in the installation. For example, assume ambient air is used as the cooling medium within the condenser, and assume the ambient air for the particular climate where the device is installed is not capable of providing adequate cooling for the selected number of desiccant trays. In this scenario, the number of desiccant trays might be increased to compensate for the inability to optimally remove water from the airflow during an extraction cycle due to the unfavorable ambient air conditions.

In another aspect of the method of configuring an array, it is advantageous to provide the capability to effectively seal each desiccant tray as it is connected to another desiccant tray to ensure there is limited loss of the airflow through the device. For the vertically stacked desiccant trays, as illustrated, sealing gaskets can be used to effectively seal the trays. For laterally adjacent trays, as illustrated, it may be advantageous to use flange-type connections between the trays which provide not only structural stability, but also sealed connections without having to use additional means to seal the adjacent trays. Nonetheless, it is also contemplated that sealing gaskets could be used between laterally adjacent trays, in combination with some type of locking feature to connect the trays.

In yet another aspect of the method of configuring the array, another consideration is the creation of the optimal airflow pattern through the device. Because of the nearly limitless number of ways in which the desiccant trays may be configured, this flexibility in the design of the device also lends itself to a corresponding nearly limitless number of ways in which airflow patterns can be created. Serial flow paths, parallel flow paths, and combinations of these flow

paths may be adopted for specific installation. Laterally adjacent trays can be constructed so that a gap or open space exists at the location where the trays are connected to one another. As shown in one of the preferred embodiments, this gap or open spaces is facilitated by the removable panels, which therefore allow horizontal airflow between the laterally adjacent trays. With respect to vertically stacked trays, the number and size of airflow slots in the sidewalls of the trays can be modified to accommodate the desired airflow pattern(s) through the device.

Referring now to FIGS. 13 and 14, an example construction is provided for a valve or damper and fan combination. As shown, in the schematic diagram of FIG. 1, airflow control through the device includes various pairs of fans and dampers. Accordingly, the FIGS. 13 and 14 are intended to illustrate how these various pairs of fans and dampers may be constructed in accordance with the advantages of the modular construction of the invention. A fan assembly 150 is shown as including a fan housing 158 disposed between a pair of fan flanges 156. The fan 160 is disposed within the fan housing 158, and includes a characteristic fan hub, and a plurality of fan blades. A valve assembly 152 connects to the fan assembly. A single connecting flange 162 may be placed between the valve assembly and fan assembly. The construction of the valve assembly 152 may include two half sections, shown as upper half section 164 and lower half section 166. The flapper or valve element 168 has a mounting pin 170, which is received in the pin openings 174 of the upper half section 164. Pin locks 172 may be used to secure the ends of the mounting pin 170. As also shown in FIG. 13, an adjacent tubing or conduit section 154 may be secured to the fan also by a single connecting flange 162. Similarly, the opposite end of the valve assembly 152 may connect to an adjacent tubing section 154 by a single connecting flange 162. The tubing sections 154 may simply be frictionally received within the adjacent flanges 162. The half sections 164 and 166 may be secured to the flanges 164 also by a friction fit, as achieved by the flange extensions 176, or by some other connecting means in which substantial airflow loss is limited between the connections. As also shown, the fan 150 may be secured to its abutting flanges 162 as by a screw and nut combination. The FIGS. 13 and 14 are intended to illustrate an example construction in which pairs of fans and valves may be connected to one another in line with sections of tubing, wherein the construction is simple, reliable, and repeatable without the need for special tools or equipment. Thus, functionally distinct pairs of fans and valves of the device when installed in the device may be assembled by similar assembly methods.

In order to control the device, an integral controller 84 (FIG. 1) may be used. While manual control is also possible, use of a controller has a number of advantages to include less burdensome user efforts, and more timely and precise control of the device for producing the desired amount of water. The controller 84 may be a known industrial controller, such as a programmable logic controller (PLC).

Referring to the FIG. 15, this figure is intended to represent the controller 84 as a computing device 200 with known functionality. More specifically, FIG. 15 illustrates one embodiment of a computing device 200 comprising hardware elements that may be electrically coupled via a bus 255. The hardware elements may include one or more central processing units (CPUs) 205; one or more input devices 210 (e.g., a mouse, a keyboard, etc.); and one or more output devices 215 (e.g., a display device, a printer, etc.). The computing device 200 may also include one or more storage device 220. By way of example, storage device(s) 220 may be disk drives, optical storage devices, solid-state storage device such as a random

access memory (“RAM”) and/or a read-only memory (“ROM”), which can be programmable, flash-updateable and/or the like. The controller **200** also includes one or more input/output modules **201**. The input/output modules may be built in with the controller, or may be one or more external input/output modules that plug into the controller. For PLCs, most of these are equipped with extensive input/output module capabilities in which a wide range of inputs and outputs may be accommodated. Further, because PLCs are typically made for severe operating conditions, the use of a PLC as a controller in the device of the invention may be a preferred option.

The computing device **200** may additionally include a computer-readable storage media reader **225**; a communications system **230** (e.g., a modem, a network card (wireless or wired), an infra-red communication device, etc.); and working memory **240**, which may include RAM and ROM devices. Optionally, the computing device **200** may include a processing acceleration unit **235**, which can include a DSP, a special-purpose processor and/or the like. The computer-readable storage media reader **225** can further be connected to a computer-readable storage medium, together (and, optionally, in combination with storage device(s) **220**) comprehensively representing remote, local, fixed, and/or removable storage devices plus storage media for temporarily and/or more permanently containing computer-readable information. The communications system **230** may permit data to be exchanged with a data network and/or with another computing device within a network, as further explained below regarding FIG. **16**.

The computing device may also comprise software elements, shown as located within a working memory **240**, including an operating system **245** and/or other code **250**, such as program code implementing a program or code for operation of the device. The computing device **200** may also employ a GPS receiver **260** for location based capabilities. The GPS receiver **260** can be used to further exploit data regarding geographical and/or weather conditions to improve the operational efficiency of device. For example, the GPS receiver can be used to download data regarding orientation and duration of sunlight and the direction(s) of prevailing winds. This data can be used to update or improve the algorithms to obtain better efficiencies for solar energy extraction and to minimize fan power needs. The computing device **200** may other include a radio transceiver **265** that enables the device to have a wireless communications capability. A particular radio communications protocol may be employed depending upon geographical limitations where the device is installed, enabling the device to maintain wireless communications with a wireless communications network.

Alternate components of the computing device might also be used and/or particular elements might be implemented in hardware, software (including portable software, such as applets), or both. Further, connection to other computing devices such as network input/output devices may be employed.

Although the device has been described with the use of a computing device **200**, it is also contemplated that the device may also be controlled by one or more microcontrollers. A microcontroller is an integrated chip including a central processing unit (CPU), a memory element (such as RAM or ROM), a group of input/output ports, and timers. Microcontrollers, however, are typically designed to execute only a limited number of tasks because of the limited processor capabilities and therefore, are limited in terms of their ability to monitor numerous inputs and to generate numerous command outputs. Nonetheless, because of the relatively few

inputs and outputs of the device, a microcontroller in combination with a communications element, such as a transceiver with a wireless capability, remains as a viable solution in terms of providing control for the device.

The computing device or microcontroller(s) may also be incorporated within a communications network, as shown in the FIG. **16**. The FIG. **16** is intended to illustrate that either a computing device or microcontroller(s) be represented by the reference numeral **200**. Further, the FIG. **16** is intended to illustrate an example communication system **300** that may be used in connection with the device and method disclosed herein. The system **300** may include one or more remote general purpose computers **305** and **310** that communicate through a communications network **310** with one or more of the devices **10**, each with their own integral controller/microprocessor(s) **200**. By way of example, the general purpose computers may be personal computers and/or laptop computers running various versions of Microsoft Corp.’s Windows™ and/or Apple Corp.’s Macintosh™ operating systems) and/or workstation computers running any of a variety of commercially-available UNIX™ or UNIX-like operating systems. These remote computers **305** and **310**, may also have any of a variety of applications, including for example, database client and/or server applications, and web browser applications. Alternatively, the user computers **305** and **310** may be other electronic devices, such as an Internet-enabled mobile telephone, and/or personal digital assistant, capable of communicating via the network **320** and/or displaying and navigating web pages or other types of electronic documents. Although the exemplary system **300** is shown with two remote computers, any number of remote computers may be supported.

The network **320** may be any type of network familiar to those skilled in the art that can support data communications using any of a variety of commercially-available protocols, including without limitation TCP/IP, SNA, IPX, AppleTalk, and the like. Merely by way of example, the network **320** maybe a local area network (“LAN”), such as an Ethernet network, a Token-Ring network and/or the like; a wide-area network; a virtual network, including without limitation a virtual private network (“VPN”); the Internet; an intranet; an extranet; a public switched telephone network (“PSTN”); an infra-red network; a wireless network (e.g., a network operating under any of the IEEE 802.11 suite of protocols, the Bluetooth™ protocol known in the art, and/or any other wireless protocol); and/or any combination of these and/or other networks.

The system **300** may also include one or more server computers **325**. The server **325** may be a web server, which may be used to process requests for web pages or other electronic documents from user computers **305** and **310**. The web server can be running an operating system including any of those discussed above, as well as any commercially-available server operating systems. The web server **325** can also run a variety of server applications, including HTTP servers, FTP servers, CGI servers, database servers, Java servers, and the like. In some instances, the web server **325** may publish operations available as one or more web services.

The system **300** may also include a database **335**. The database **335** may reside in a variety of locations. By way of example, database **335** may reside on a storage medium local to (and/or resident in) one or more of the computers **305**, **310**, or on a storage medium local to one or more of the controllers/microprocessor(s) **200** of the devices **10**. Alternatively, the database **335** may be remote from any or all of the computers or controllers, and in communication (e.g., via the network **320**) with one or all of the computers and controllers. The

database 335 may reside in a storage-area network (“SAN”) familiar to those skilled in the art. Similarly, any necessary files for performing the functions attributed to the computers and/or controllers/microprocessors may be stored remote from or locally on the respective computers or controllers. 5 The database 335 may be a relational database, such as Oracle 10i™, that is adapted to store, update, and retrieve data in response to SQL-formatted commands.

As also shown in the FIG. 16, the controllers/microprocessor(s) 200 each communicate with other components of the system 300 through the network 320. Although the controllers/microprocessors 200 may have the capability to independently operate and control their corresponding devices 10, additional features of the invention may be available when the controllers are incorporated within the communication system 300. For example, if a device is moved from one location to another, the controller could receive updated algorithms that provide more closely matched programming features corresponding to the particular environment in which the devices may operate. Additionally, software or other command updates may be downloaded to the controllers/microprocessors thereby eliminating the need for manual software updates. Additionally, information may be uploaded from the controllers/microprocessors. This information may be used as historical operating data to improve software programming or other aspects of control for the devices. Since the devices may be operating in remote or austere conditions, the capability for the controllers to communicate through a communications network can provide other benefits. For example, if a controller experiences a malfunction or suffers from a reduced functional capacity, it would be possible to bypass control of the device as normally provided by the controller/microcontroller by commands sent through one or more of the remote computers. In the event there are a multitude of devices functioning simultaneously within one or more locations, the computing capability of the server 325 may be advantageous in providing additional or supplemental control to the devices. Additionally, the database 335 can be useful in compiling operational data for the devices in order to improve the sets of algorithms and software commands that may be associated with operation of the devices. Those skilled in the art can appreciate other advantages of incorporating a device 10 within a communication system 300.

In accordance with methods of the present invention, a device removes water vapor from an incoming, ambient airstream. The exhaust airstream leaving the device is therefore a dried or water lean airstream. Operation of the device can conceptually be divided into two main cycles, namely, a charge cycle and an extraction cycle. In the charge cycle, the ambient airstream is passed through a chamber, across a desiccant stack, and back to the environment. The desiccant absorbs water vapor in the air stream. The desiccant is preferably employed in a liquid solution with water. The desiccant solution is distributed in the chamber by a desiccant media, including a plurality of media sheets, preferably in folded media sheets configured within media cartridges disposed in each tray of the desiccant stack.

In accordance with the methods, a charge cycle includes absorption of water vapor, and controlling the amount of water vapor removed from the airstream such that the desiccant solution does not become over saturated with water. In arid climates, it may be advantageous to run the charge cycle during nighttime hours when the relative humidity rises due to a corresponding drop in ambient air temperature. A controlled flow of air is passed through the chamber of the device by one or more fans. As set forth above in the illustrated preferred embodiment, one or more fans may be located at the

entrance to the chamber, coupled with one or more fans located at the exit of the chamber. Airflow sensors along with temperature and humidity sensors monitor the state of the chamber. An optimum airflow through the chamber is achieved to match the desired quantity of water to be recovered. If a relatively small amount of water is the recovery requirement, then a smaller volume of air is passed through the chamber as compared to a larger water recovery requirement that must be attained in the same amount of operation time. Once the desiccant media has absorbed the requisite amount of water for the charge cycle, an extraction cycle is commenced. First, the chamber is isolated from the ambient airstream by closing all valves or dampers that communicate with the surrounding environment. Heat energy is added to the chamber. This may be achieved by use of a heat exchanger that has many possible sources of power. Heat energy is added to a predetermined point in which vaporization occurs for the water within the chamber. At this point, the moist air within the chamber can be circulated through a condenser. Preferably, the condenser does not require a separate source of power for cooling. Rather, it is preferred to initiate condensing when the internal temperature within the chamber exceeds a dew point temperature relative to the external ambient temperature. Accordingly, the cooling “source” for the condenser is simply the ambient air, and a flow of ambient air is passed through the condenser to achieve condensing of the moist chamber air. The condenser has a passageway, typically defined by a cooling coil, in which the cooler temperature of the coil causes the water vapor to condense. Water droplets condensed on the surfaces of the condensing coil are collected in a container that communicates with the condensing coil. During this condensing phase of the extraction cycle, heat continues to be added to the chamber for a period of time to evaporate a desired amount of water trapped within the chamber. Accordingly, recirculation of the air within the chamber occurs in which a return line is provided from the condenser back to the chamber. In addition to adding heat to the chamber, the vaporization temperature of the water can be more easily achieved by reducing the pressure within the chamber. For example, a partial vacuum can be drawn for the air within the chamber, and the remaining amount of air within the chamber can be heated and re-circulated during the condensing phase.

Further in accordance with methods of the invention, it is contemplated that optimal desiccant solution ratios are maintained for each reservoir of solution within each tray. Liquid level sensors along with chemical concentration sensors may be employed in each tray to monitor liquid levels and desiccant concentrations. As needed, desiccant solution can be replaced and/or water may be automatically added to each tray as supplied from supply reservoirs that communicate with each of the trays.

Further in accordance with methods of the invention, it should be apparent that the use of desiccant trays provides distinct advantages in controlling amounts of desiccant used, as well as providing the capability to recover and reuse saturated desiccant that drips back into the desiccant trays. More specifically, during a charge cycle, some amount of the desiccant may become saturated, and therefore may by gravity drip into the corresponding desiccant tray. In this situation, the desiccant is recovered and can be reused again after the extraction cycle. In the extraction cycle, the desiccant is returned to a more balanced concentration through the drying action achieved in the extraction cycle. Consequently in the next charge cycle, the desiccant in solution will therefore be wicked back up through the media material.

Further in accordance with methods of the invention, it should be apparent that the use of desiccant trays provides distinct advantages in providing the capability to recover and reuse dried desiccant particles that may dislodge from the media material as well. In this situation, some portion of the desiccant may dry and adhere to the media material during an extraction cycle, and some particles will inevitably become dislodged and fall. The desiccant tray will capture these particles, and the liquid remaining in the desiccant tray will allow the particles to be automatically placed back into solution, and therefore made ready for reuse.

Further in accordance with methods of the invention, the dried airstream that is produced during a charge cycle can be used to condition the interior airspace of a man-made structure. Accordingly, duct work may be connected to the exhaust airstream interconnecting the exhaust airstream with the interior airspace.

Also in accordance with methods of the invention, the modular construction of the device allows for easily changing the water recovery capacity of the device. Therefore, it is contemplated that water recovery capability can be optimized by changing the number of trays used by changing the exposed surface area of the media cartridges, and/or changing the flow path of air through the chamber. As discussed, a serial flow path through the chamber or a parallel flow path through the chamber changes the dwell time of the airstream within the chamber. These different flow paths also result in greater or lesser contact of the desiccant media with the airstream which, in turn, alters the rate at which water is absorbed by the desiccant. Additionally, the flow rate of air through the chamber of the device can also be adjusted to meet the desired water recovery requirement. In general, a greater flow rate of air through the chamber should result in a greater amount of water recovered as compared to a lesser flow rate.

Also in accordance with methods of the invention, it is contemplated that dynamic programming is used with a controller/microprocessor to optimize device operation. Within the controller/microprocessor programming, algorithms can be used that establish base line or initial operation parameters based upon known environmental factors. These environmental factors include daily temperature data, daylight data, humidity data, wind data, and potential damage scenario data. Each of these factors may ultimately affect the operation of the device. With respect to temperature and humidity data, this data will partially determine optimum times for operating the cycles of the device. The daylight data also helps to define when temperature and humidity changes will most rapidly occur during average temperature conditions. Wind data can be used to ensure the device is oriented in the proper direction such that a constant flow of air can be provided through the device without undue affects of adverse wind conditions. Potential damage scenarios relate to the specific location where the device is placed, and the chances that a human or environmental event will damage or destroy the device. By evaluating each of these factors as compared to different geographical locations, initial setup and operation of a device is simplified and initially optimized. As a particular device is placed into operation, continued monitoring of environmental conditions along with the operational capability of the device can be used to alter the initial operational algorithms to then establish optimal operational parameters. Because multiple devices may be employed in austere or difficult to travel locations, it is also advantageous to incorporate the devices within a communications network in which operation of the devices may also be controlled remotely. For example, consider a device that has been damaged, or has one or more components that are not functioning to capacity. In this sce-

nario, commands may be issued from a remote computing device to change the current operational algorithms to compensate for the damage to components. One specific example could relate to a component such as a fan or valve that has limited functioning, and therefore, the operational algorithm could be modified to change the operation of these elements in order to meet the desired water recovery goal.

Also in accordance with methods of the present invention, it may be possible to determine the optimum times for running a charge cycle simply by evaluating nighttime hours. For example, light sensors and a time of day clock may be used by the controller to initiate and terminate a charge cycle, the conclusion in this method of control being that nighttime hours are the best for running the charge cycle.

Further in accordance with methods of the invention, it is contemplated that the recovered water may be further treated to ensure it is potable. For example, a number of additional water treatment measures may be taken to make the water potable. Such measures may include filtration, exposure to ultraviolet light, mineralization, chlorination, and/or further chemical treatment.

Further in accordance with methods of the invention, it is contemplated that in lieu of a single heat exchanger, a desiccant stack may take advantage of multiple heat exchanging assemblies powered by a single source of power. Accordingly, selected trays within a desiccant stack may be disposed between one or more heat exchanging assemblies in which each assembly has a heating line, a heat distribution element, and sensors. These assemblies may each have their own housing, or the trays may be modified to incorporate the heat exchanging assemblies in which a single housing can be used for both a desiccant tray and heat exchanging assembly combination.

While illustrative embodiments have been described in detail herein, it is to be understood that the concepts may be otherwise variously embodied and employed, and that the appended claims are intended to be construed to include such variations, except as limited by the prior art.

What is claimed is:

1. A water recovery device comprising:
  - a desiccant stack including a chamber defining an airflow path therein, the stack including a plurality of desiccant trays, each desiccant tray including a desiccant media cartridge and an amount of liquid desiccant placed within the desiccant tray and being absorbed by a media material of the media cartridge;
  - the plurality of desiccant trays being configured in an array comprising at least one column of vertically stacked desiccant trays and a row of laterally adjacent desiccant trays.
  - a condenser communicating with the desiccant stack;
  - a heat exchanger communicating with the desiccant stack for providing heat to the desiccant stack;
  - wherein the water recovery device is operated in a charge cycle for circulating ambient air through the chamber to remove water vapor by the liquid desiccant and retaining water vapor in the chamber, the water recovery device being further operated in an extraction cycle to remove the retained water vapor within the chamber, the condenser providing a cooling source to condense the water vapor and thereby producing an amount of water condensate.
2. A water recovery device, as claimed in claim 1, further comprising:
  - a controller incorporated in the device for controlling functioning of the device to include the charge cycle and the extraction cycle, the device further including a plurality

25

of sensors as inputs to the controller, and a plurality of valves and fans as outputs of the controller, the valves and fans being located within air transport lines of the device.

3. A water recovery device, as claimed in claim 1, wherein: 5  
each desiccant tray includes a plurality of sidewalls and a base, the liquid desiccant being placed in the base, and the media cartridge being partially submerged within the liquid desiccant.
4. A water recovery device, as claimed in claim 1, wherein: 10  
the ambient air circulated through the chamber is an airstream in which the airstream takes a directed flow path through the chamber, the directed flow path including at least one of a serial flow path, a parallel flow path, or a combination thereof. 15
5. A water recovery device, as claimed in claim 1, wherein: each tray has a plurality of sidewalls and a base containing an amount of the liquid desiccant therein, at least one of the sidewalls or base having a plurality of air circulating slots formed therein to enable the ambient air to be circulated through the slots. 20
6. A water recovery device, as claimed in claim 1, wherein: the plurality of desiccant trays include trays that are stacked vertically upon one another, and the ambient air being capable of flowing through each of said stacked trays. 25
7. A water recovery device, as claimed in claim 1, wherein: the array includes at least one column of vertically stacked desiccant trays, and the ambient air flowing through each of said trays in one of a serial or parallel flow path. 30
8. A water recovery device, as claimed in claim 1, wherein: the array includes at least one row of two laterally adjacent desiccant trays, and the ambient air flowing through said trays flows horizontally between each of said desiccant trays. 35
9. A water recovery device, as claimed in claim 1, wherein: the array includes at least two columns of vertically stacked desiccant trays, and the ambient air flowing through each of said trays in one of a serial or parallel flow path, and further wherein the flow path flows horizontally between two laterally adjacent desiccant trays. 40
10. A water recovery device, as claimed in claim 1, wherein: 45  
the array is provided in an irregular configuration, the array includes at least two columns of vertically stacked desiccant trays, and the ambient air flowing through each of said trays in one of a serial or parallel flow path, and further wherein the flow path flows horizontally between two laterally adjacent desiccant trays. 50
11. A water recovery device, as claimed in claim 1, wherein: at least two of the trays include connection means for connecting two laterally adjacent trays. 55
12. A water recovery device, as claimed in claim 11, wherein: one tray of the at least two trays includes a connecting flange, and the other tray of the at least two trays includes a connecting extension connected to the connecting flange, thereby facilitating attachment between the at least two trays. 60
13. A water recovery device, as claimed in claim 11, wherein: at least two of the trays each include a sidewall track assembly and a removable panel secured in the sidewall track assembly, the panels being removed enabling lat-

26

erally adjacent trays connected to one another to facilitate airflow horizontally between the laterally adjacent trays.

14. A water recovery system comprising:  
(a) water recovery device including:  
(1) a desiccant stack including a chamber defining an airflow path therein, the stack including a plurality of desiccant trays, each desiccant tray including a desiccant media cartridge and an amount of liquid desiccant placed within the desiccant tray and being absorbed by a media material of the media cartridge;  
(2) the plurality of desiccant trays being configured in an array comprising at least one column of vertically stacked desiccant trays and a row of laterally adjacent desiccant trays;  
(3) a condenser communicating with the desiccant stack;  
(4) a heat exchanger communicating with the desiccant stack for providing heat to the desiccant stack;  
wherein the water recovery device is operated in a charge cycle for circulating ambient air through the chamber to remove water vapor by the liquid desiccant and retaining water vapor in the chamber, the water recovery device being further operated in an extraction cycle to remove the retained water vapor within the chamber, the condenser providing a cooling source to condense the water vapor and thereby producing an amount of water condensate;  
(b) a controller incorporated in the device for controlling functioning of the water recovery device to include the charge cycle and the extraction cycle, the water recovery device further including a plurality of sensors as inputs to the controller, and a plurality of valves and fans as outputs of the controller, the valves and fans being located within air transport lines of the water recovery device;  
(c) said water recovery device further including a communications node incorporated within a communications system enabling the water recovery device to communicate within the communications system.
15. A water recovery system, as claimed in claim 14, wherein: the plurality of desiccant trays include trays that are stacked vertically upon one another, and the ambient air being capable of flowing through each of said stacked trays.
16. A water recovery system, as claimed in claim 14, wherein: the array includes at least one column of vertically stacked desiccant trays, and the ambient air flowing through each of said trays in one of a serial flow path or parallel flow path.
17. A water recovery system, as claimed in claim 14, wherein: the array includes at least one row of two laterally adjacent desiccant trays, and the ambient air flowing through said trays flows horizontally between each of said desiccant trays.
18. A water recovery system, as claimed in claim 14, wherein: the array includes at least two columns of vertically stacked desiccant trays, and the ambient air flowing through each of said trays in one of a serial or parallel flow path, and further wherein the flow path flows horizontally between two laterally adjacent desiccant trays.
19. A water recovery system, as claimed in claim 14, wherein:

27

the array is provided in an irregular configuration, the array includes at least two columns of vertically stacked desiccant trays, and the ambient air flowing through each of said trays in one of a serial or parallel flow path, and further wherein the flow path flows horizontally between two laterally adjacent desiccant trays.

20. A water recovery system, as claimed in claim 14, wherein:

at least two of the trays include connection means for connecting two laterally adjacent trays.

21. A water recovery system, as claimed in claim 14, wherein:

one tray of the at least two trays includes a connecting flange, and the other tray of the at least two trays includes a connecting extension connected to the connecting flange, thereby facilitating attachment between the at least two trays.

22. A water recovery system, as claimed in claim 14, wherein:

at least two of the trays each include a sidewall track assembly and a removable panel secured in the sidewall track assembly, the panels being removed enabling laterally adjacent trays connected to one another to facilitate airflow between the laterally adjacent trays.

23. A method of configuring an array of desiccant trays for use in a water recovery device, said method comprising:

providing a plurality of desiccant trays;  
determining installation specific requirements for the water recovery device;

28

configuring the desiccant trays in an array having a plurality of the desiccant trays arranged in a vertical column or a horizontal row, each column and row having a plurality of desiccant trays taking into consideration the requirement;

determining an optimal airflow arrangement for the chosen array configuration; and

adjusting sidewalls of the desiccant trays to facilitate the optimum airflow, said adjusting step including manipulating at least one removable panel for airflow between two laterally adjacent desiccant trays or manipulating a size of the slots of said sidewalls for airflow between two vertically stacked desiccant trays in a vertical column.

24. A method, as claimed in claim 23, wherein:

the requirements including at least one of a water recovery output requirement, site specific size and mounting constraints, an available number of desiccant trays, condensation capabilities, and heating capabilities.

25. A method, as claimed in claim 23, further including: providing sealed connections between laterally adjacent desiccant trays, said sealed connections being achieved by a friction fit of connecting components.

26. A method, as claimed in claim 23, further including: providing sealed connections between vertically stacked desiccant trays, said sealed connections being achieved by sealing gaskets placed between said desiccant trays.

\* \* \* \* \*

UNITED STATES PATENT AND TRADEMARK OFFICE  
**CERTIFICATE OF CORRECTION**

PATENT NO. : 9,017,456 B2  
APPLICATION NO. : 13/714006  
DATED : April 28, 2015  
INVENTOR(S) : Charles Becze et al.

Page 1 of 1

It is certified that error appears in the above-identified patent and that said Letters Patent is hereby corrected as shown below:

Claims

At Column 28, lines 4-5, Claim 23, please delete the word “requirement” and replace it with --requirements-- therein.

Signed and Sealed this  
Eighth Day of December, 2015



Michelle K. Lee  
*Director of the United States Patent and Trademark Office*