

US008990994B2

(12) **United States Patent**
Hughes et al.

(10) **Patent No.:** **US 8,990,994 B2**
(45) **Date of Patent:** ***Mar. 31, 2015**

(54) **MULTILAYERED CLEANING WIPE**

(56) **References Cited**

(71) Applicant: **The Procter & Gamble Company**,
Cincinnati, OH (US)

U.S. PATENT DOCUMENTS

(72) Inventors: **Jeanne Marie Hughes**, Loveland, OH
(US); **Jonathan David Gummow**,
Loveland, OH (US); **Anna Elizabeth**
Macura, Loveland, OH (US); **Brian**
Joseph Roselle, Fairfield, OH (US)

4,601,938	A *	7/1986	Deacon et al.	428/153
4,797,310	A	1/1989	Barby et al.	
5,628,097	A	5/1997	Benson et al.	
5,804,286	A	9/1998	Quantrille et al.	
5,840,675	A	11/1998	Yeazell	
5,895,504	A	4/1999	Sramek et al.	
5,916,661	A	6/1999	Benson et al.	
6,436,216	B1	8/2002	Grover	
6,720,279	B2	4/2004	Cree et al.	
6,993,805	B2	2/2006	Prodoehl et al.	
7,030,046	B2	4/2006	Wong et al.	
7,696,109	B2	4/2010	Ouellette et al.	
7,917,985	B2	4/2011	Dorsey et al.	
7,947,086	B2	5/2011	Panandiker et al.	
2006/0052269	A1	3/2006	Panandiker et al.	

(73) Assignee: **The Procter & Gamble Company**,
Cincinnati, OH (US)

(*) Notice: Subject to any disclaimer, the term of this
patent is extended or adjusted under 35
U.S.C. 154(b) by 0 days.

This patent is subject to a terminal dis-
claimer.

FOREIGN PATENT DOCUMENTS

(21) Appl. No.: **13/967,708**

DE	2611880	9/1977
EP	1789525 B1	11/2011
WO	2009/028952 A1	3/2009

(22) Filed: **Aug. 15, 2013**

OTHER PUBLICATIONS

(65) **Prior Publication Data**

US 2014/0109332 A1 Apr. 24, 2014

Related U.S. Application Data

(63) Continuation-in-part of application No. 13/657,241,
filed on Oct. 22, 2012, now Pat. No. 8,914,935.

PCT Search Report and Written Opinion for PCT/US2013/066020
dated Jan. 2, 2014.

U.S. Appl. No. 13/657,231, filed Oct. 22, 2012, Gummow et al.

U.S. Appl. No. 13/657,241, filed Oct. 22, 2012, Gummow et al.

U.S. Appl. No. 13/967,723, filed Aug. 13, 2013, Gummow et al.

* cited by examiner

(51) **Int. Cl.**

A47L 13/17 (2006.01)

Primary Examiner — Randall Chin

(52) **U.S. Cl.**

CPC **A47L 13/17** (2013.01)

USPC **15/104.93**

(74) *Attorney, Agent, or Firm* — Gary J. Foose; Larry L.
Huston

(58) **Field of Classification Search**

CPC **A47L 13/17**

USPC **15/104.93**

See application file for complete search history.

(57) **ABSTRACT**

A multilayered premoistened cleaning wipe.

19 Claims, 14 Drawing Sheets

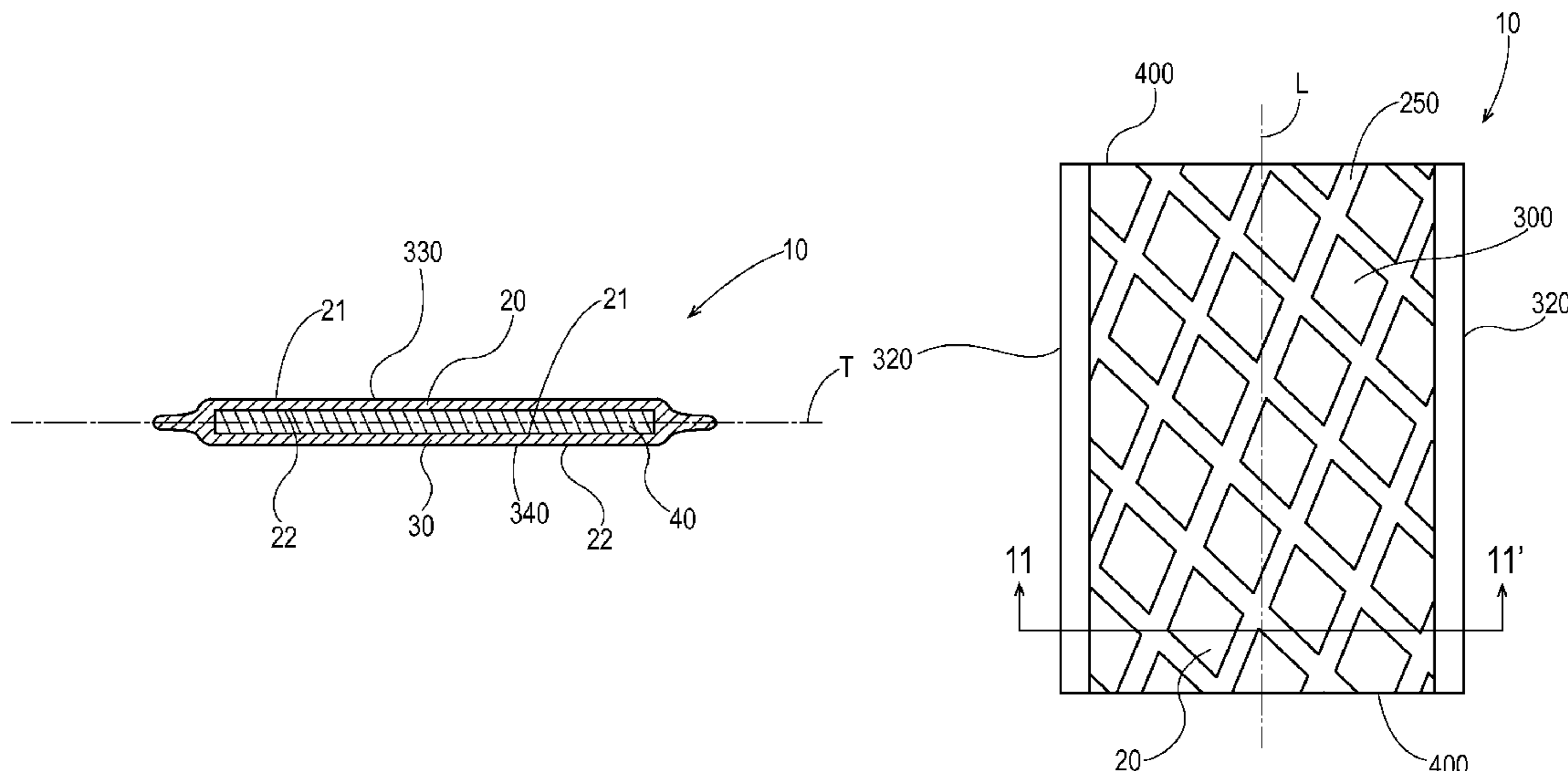

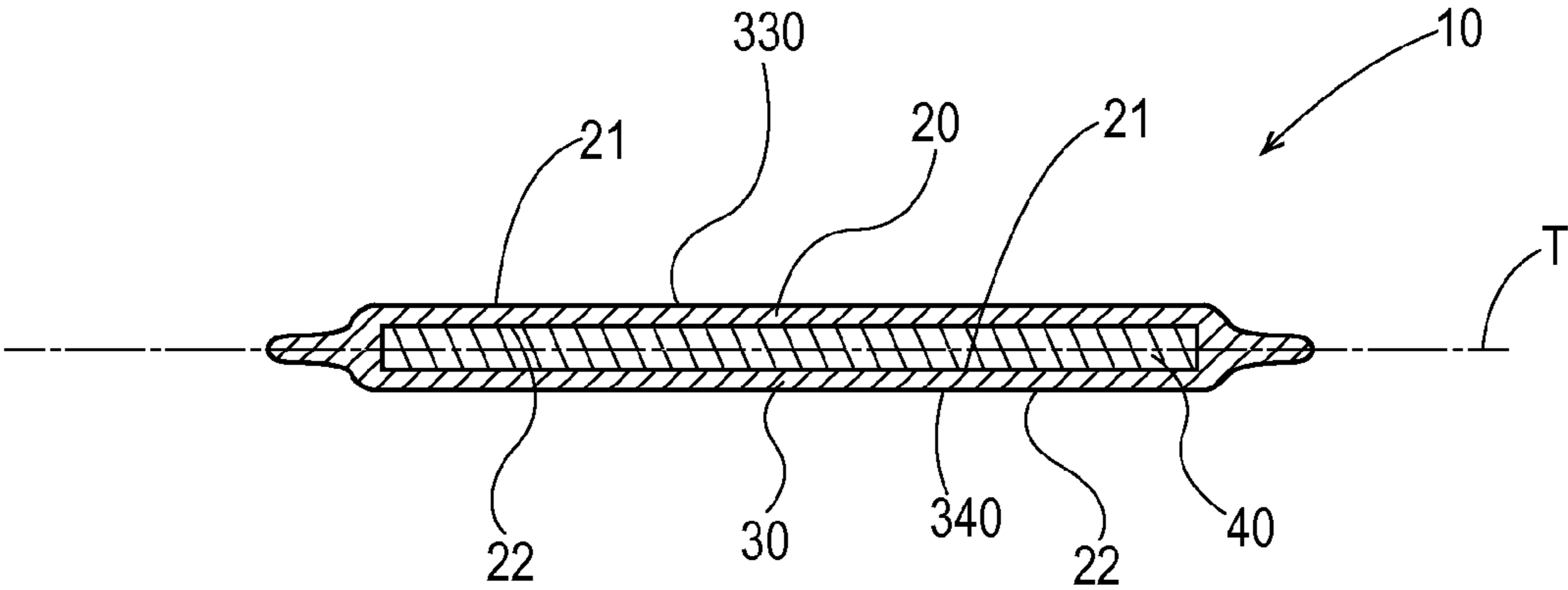

Fig. 1

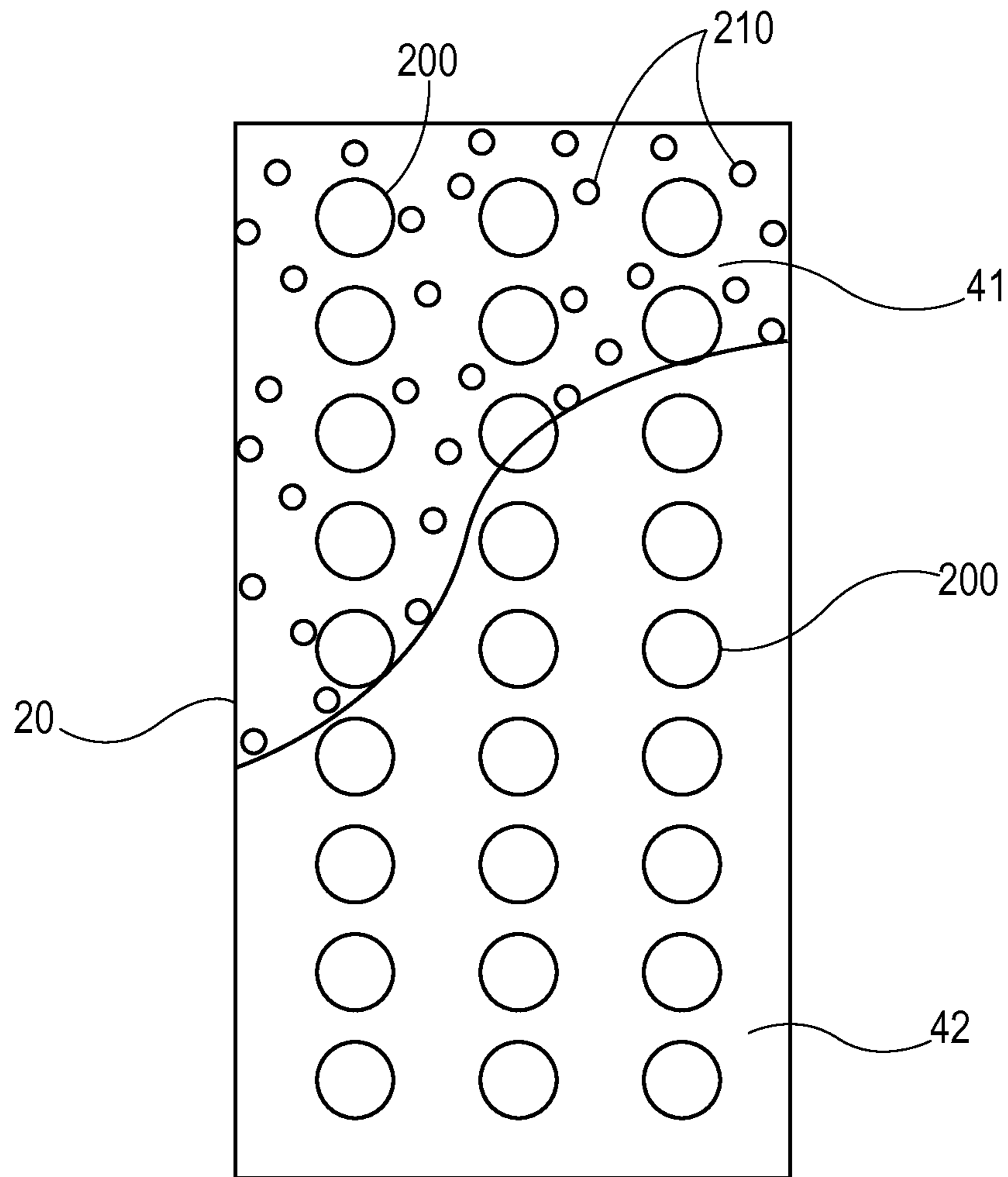

Fig. 2

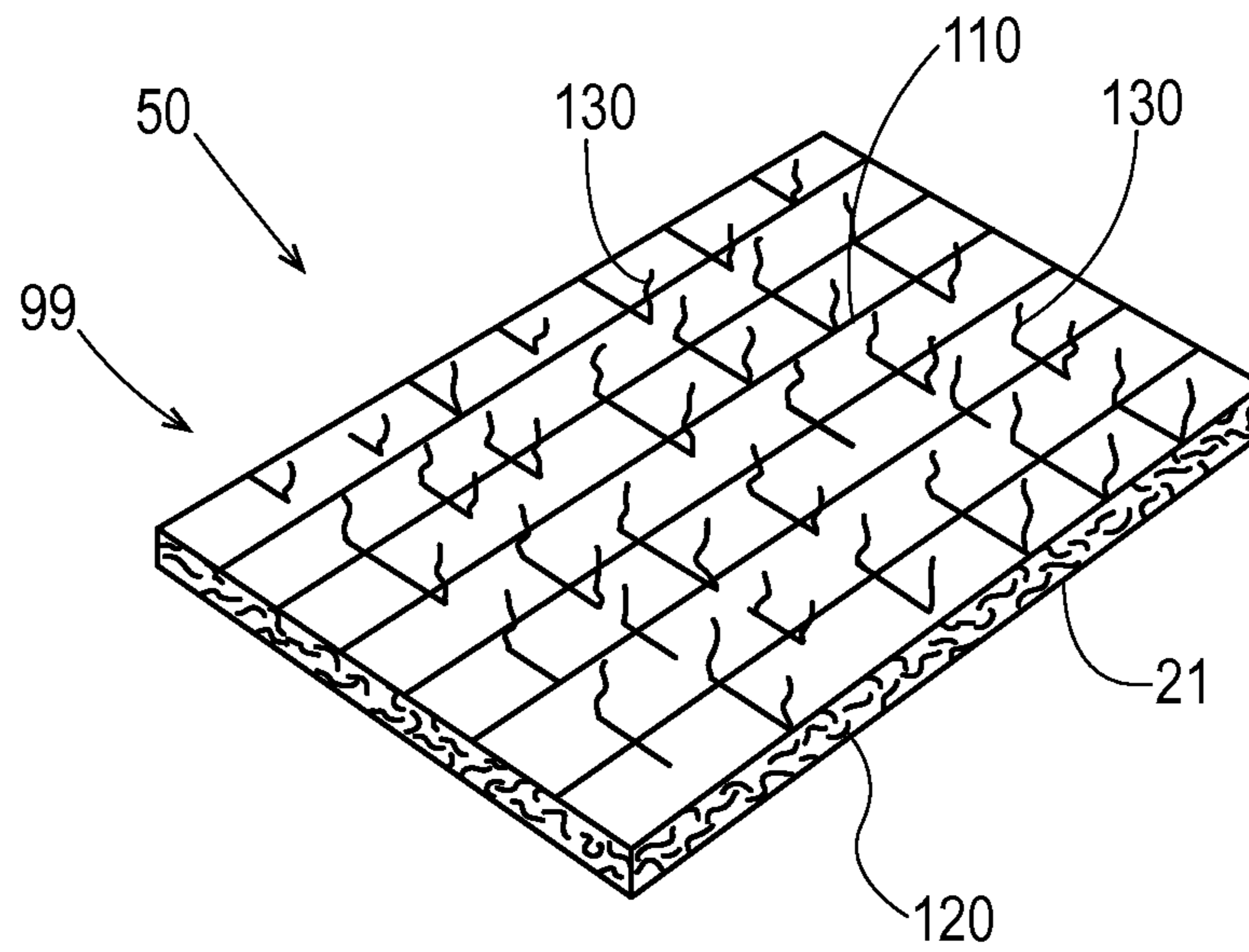
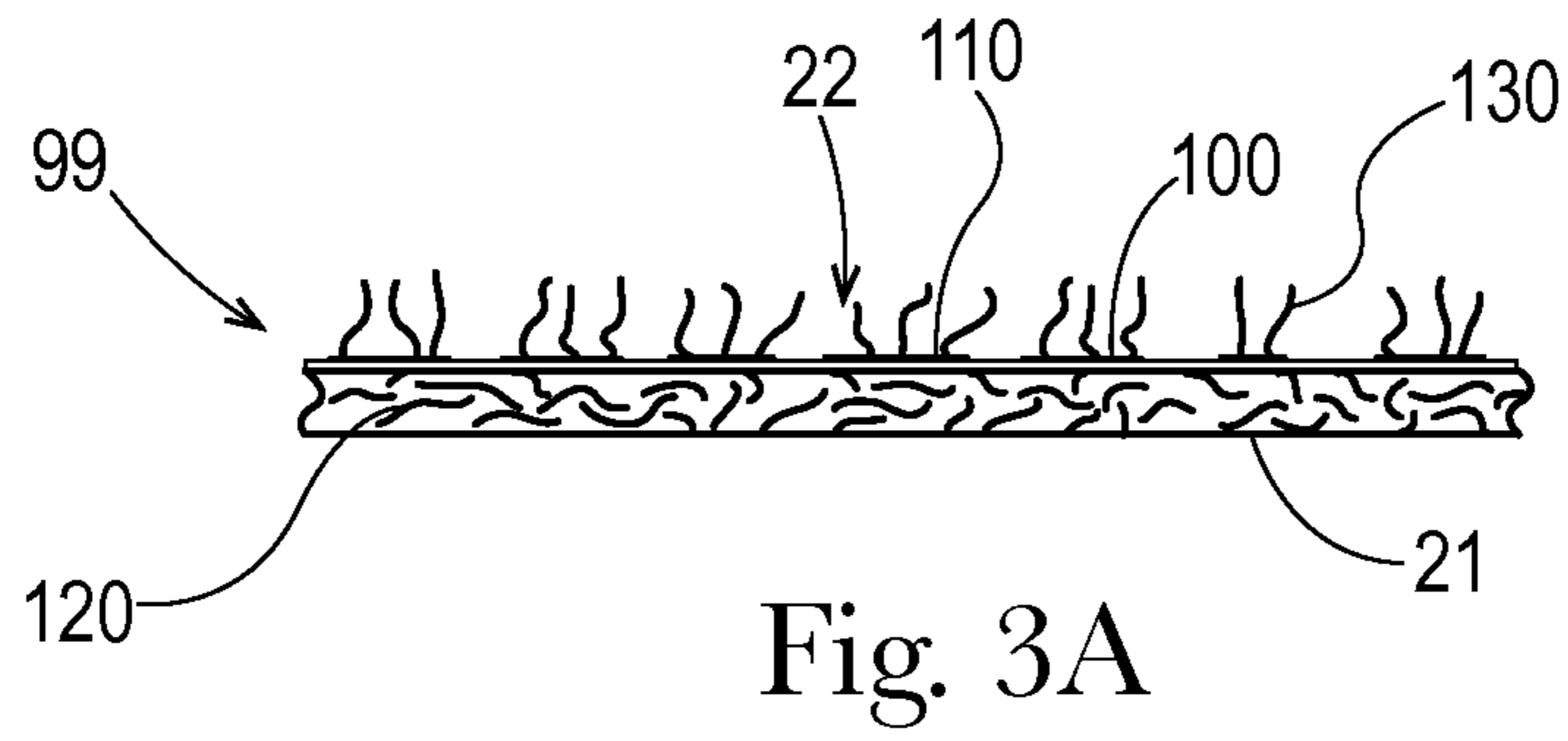

Fig. 3B

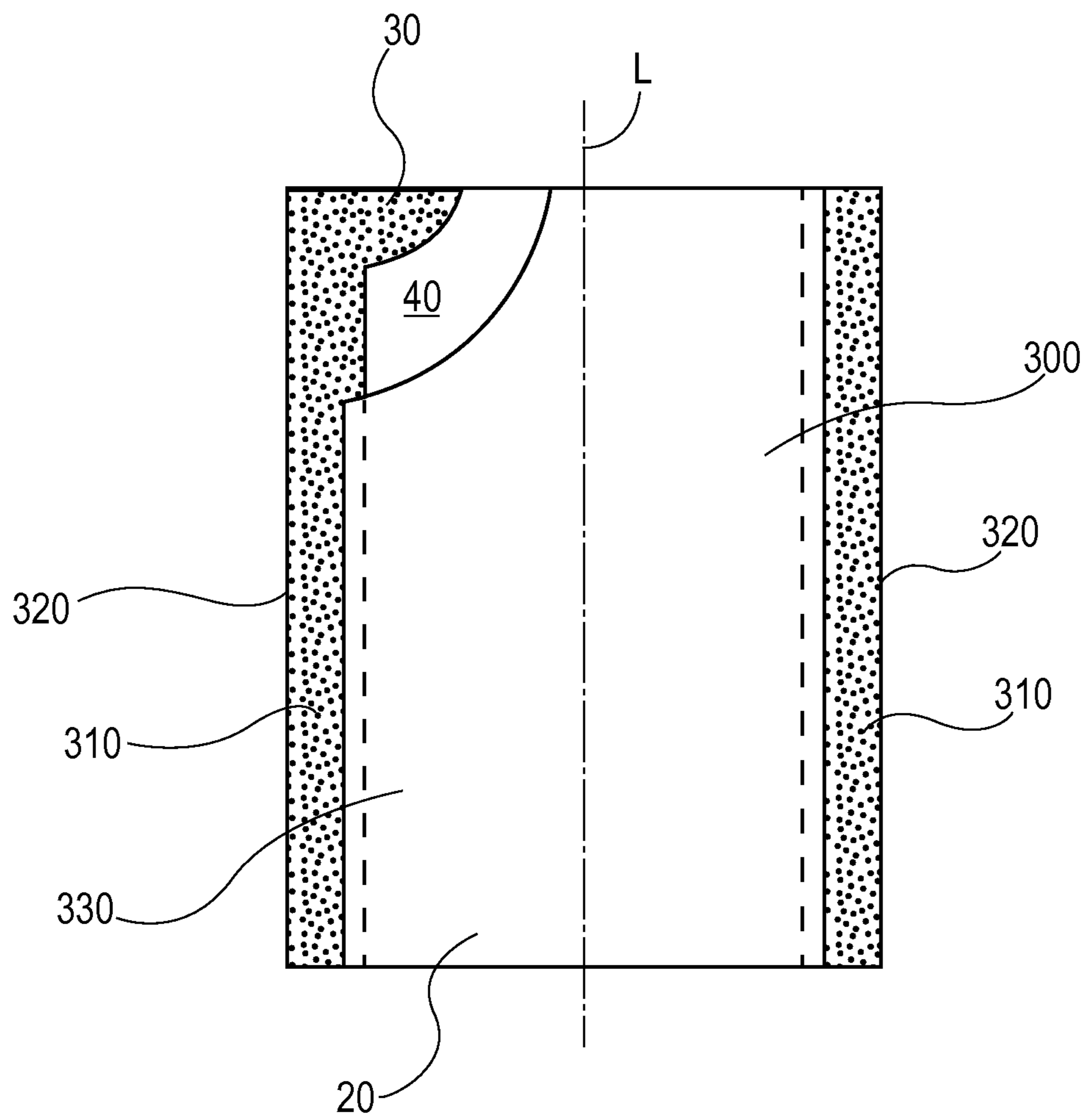

Fig. 4

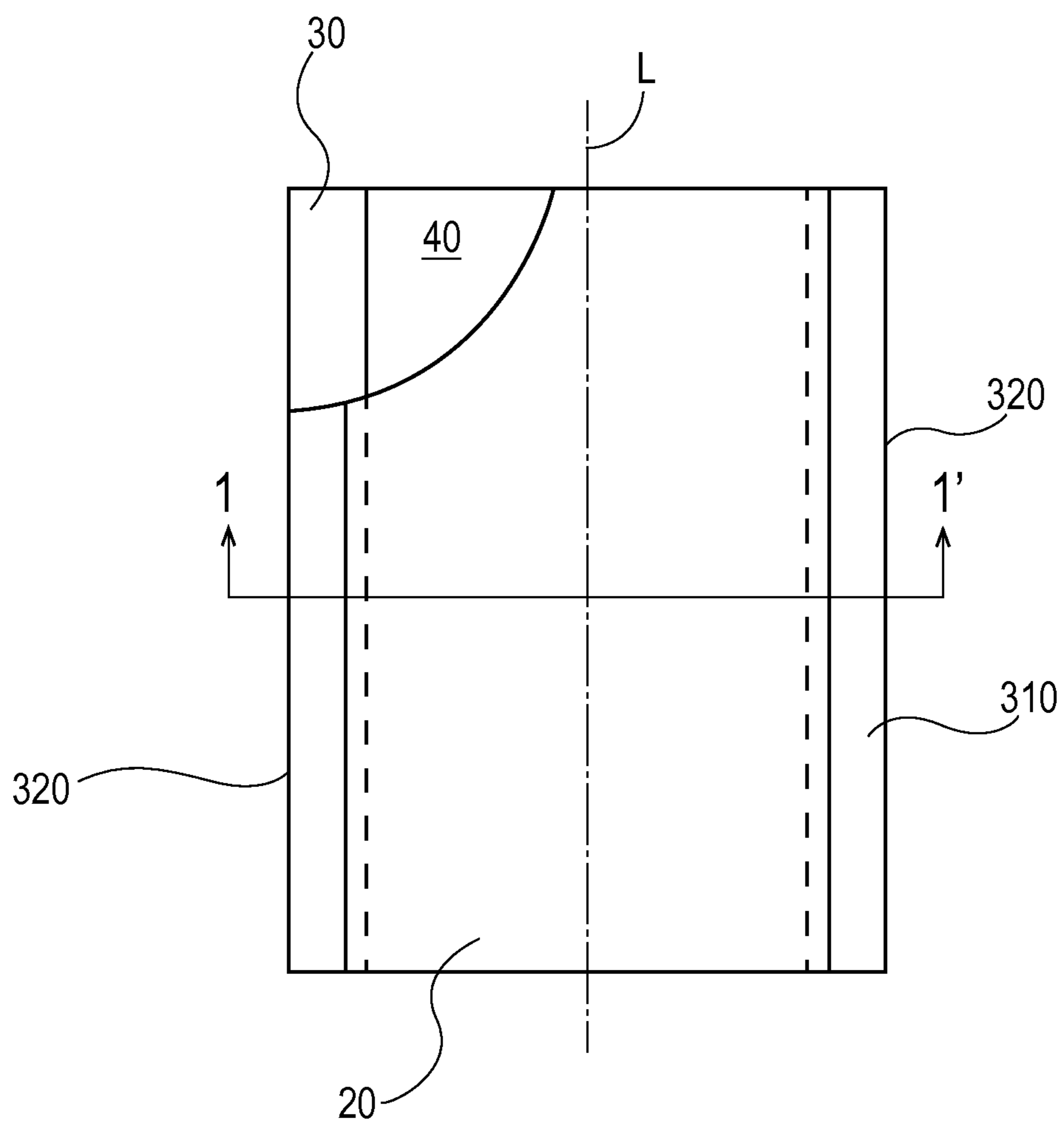

Fig. 5

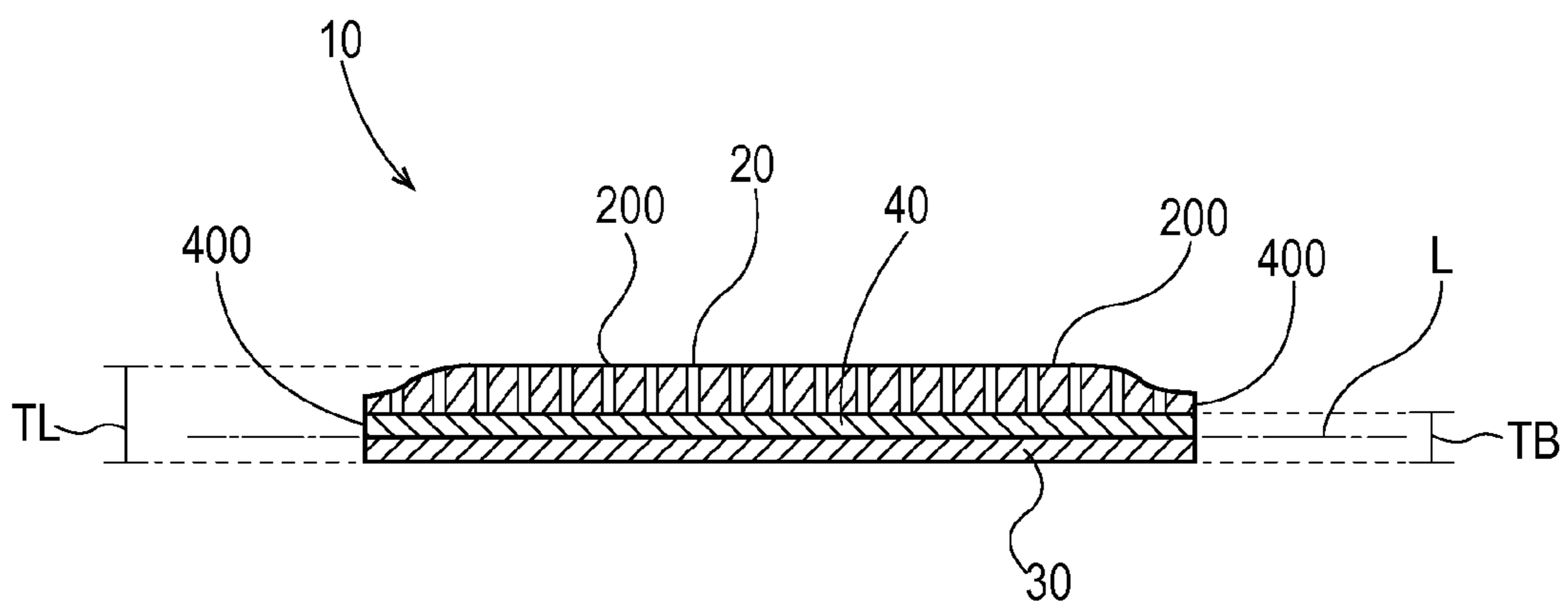

Fig. 6

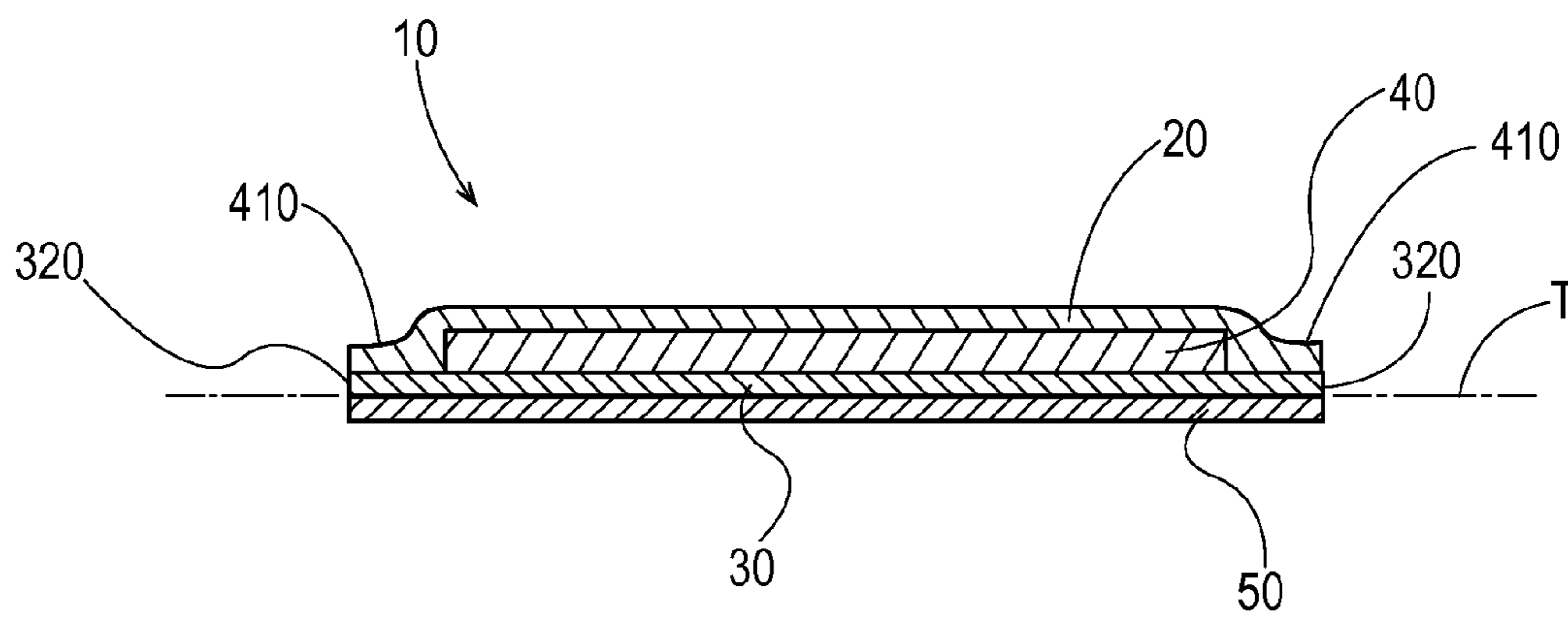

Fig. 7

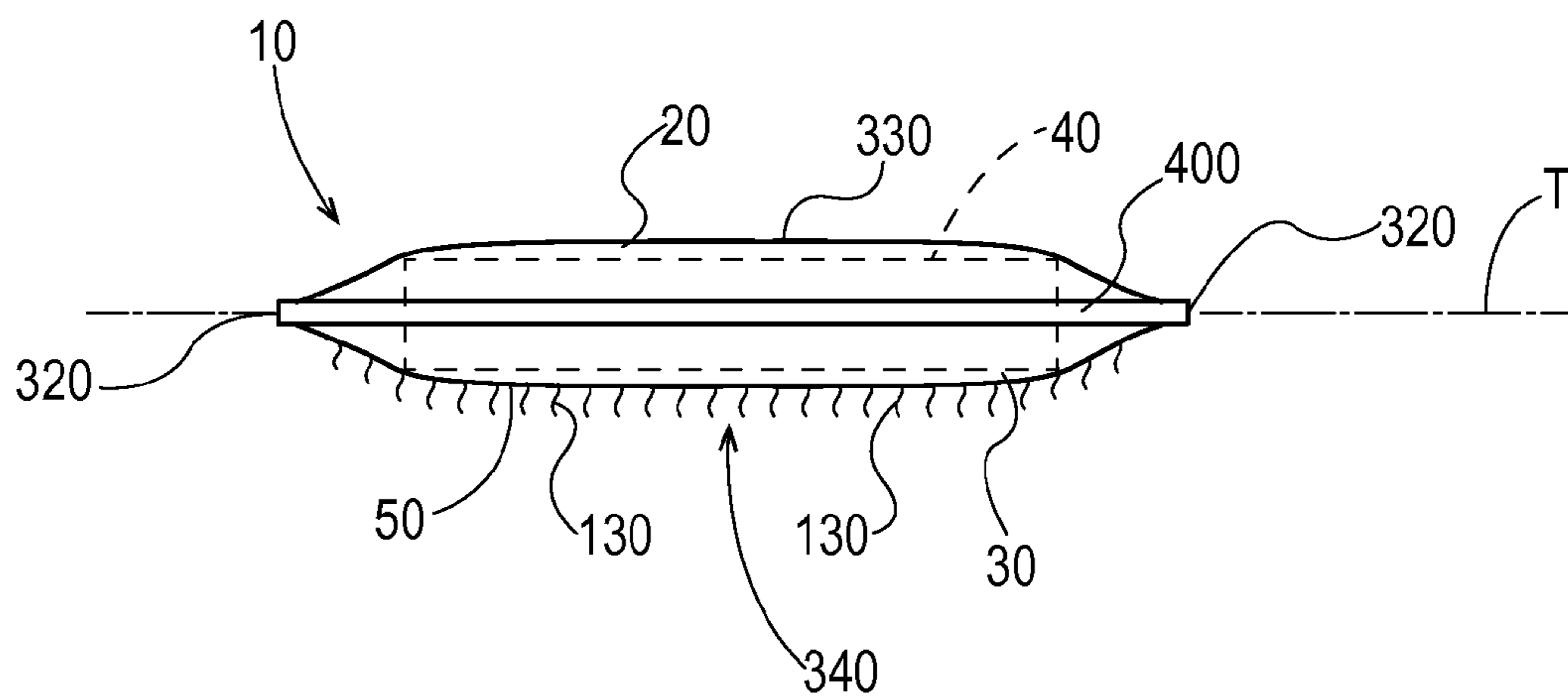

Fig. 8

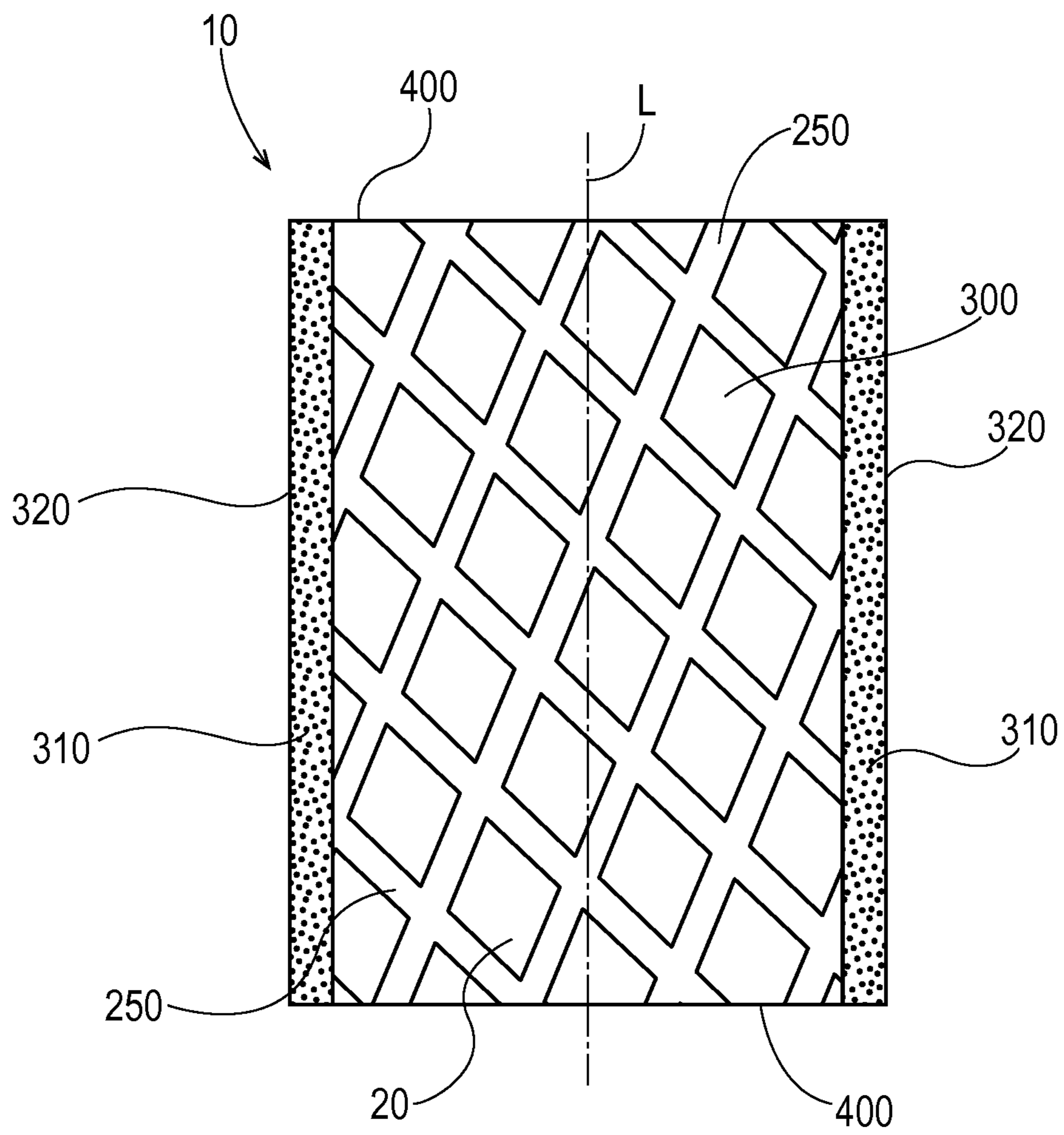

Fig. 9

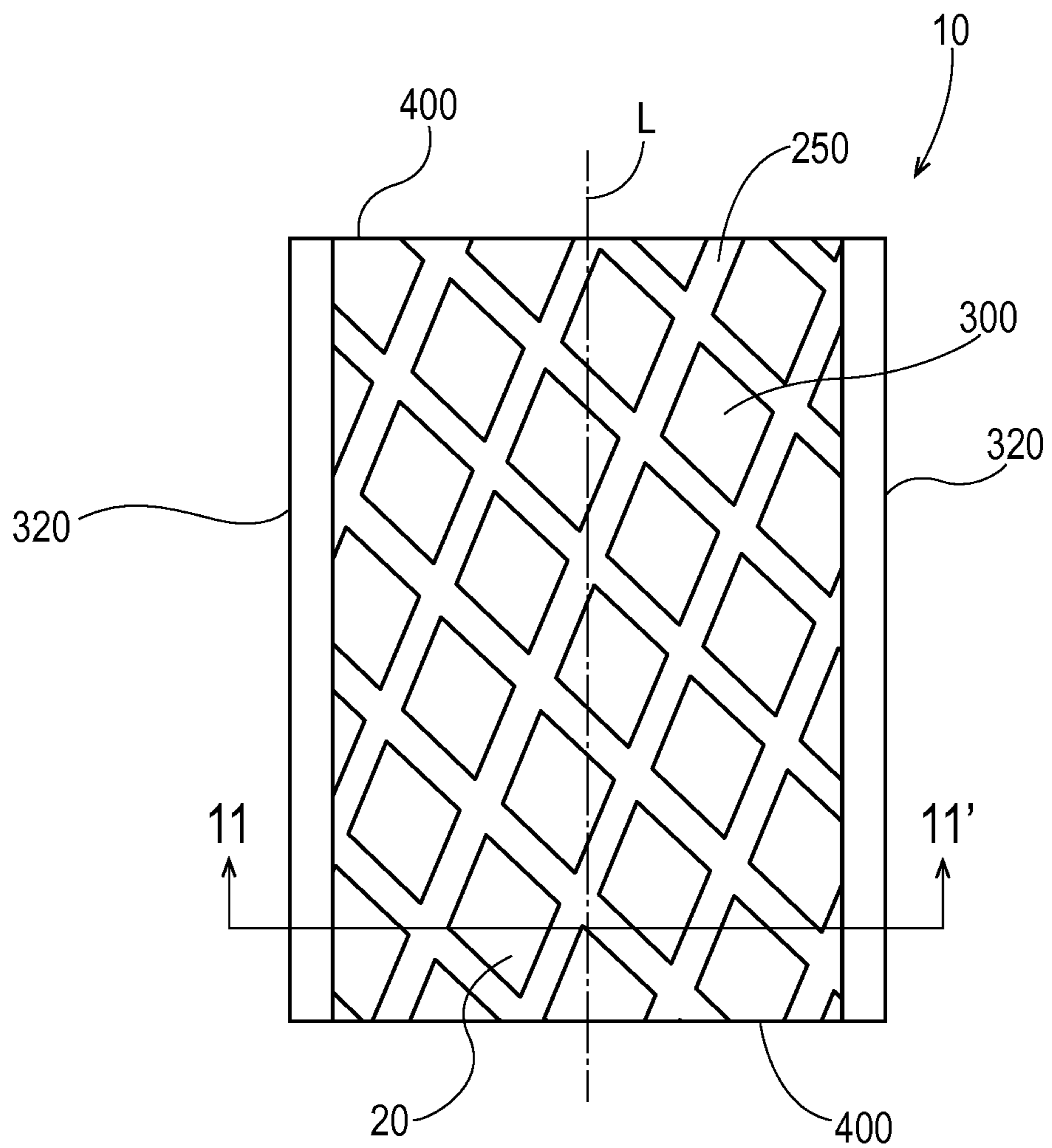

Fig. 10

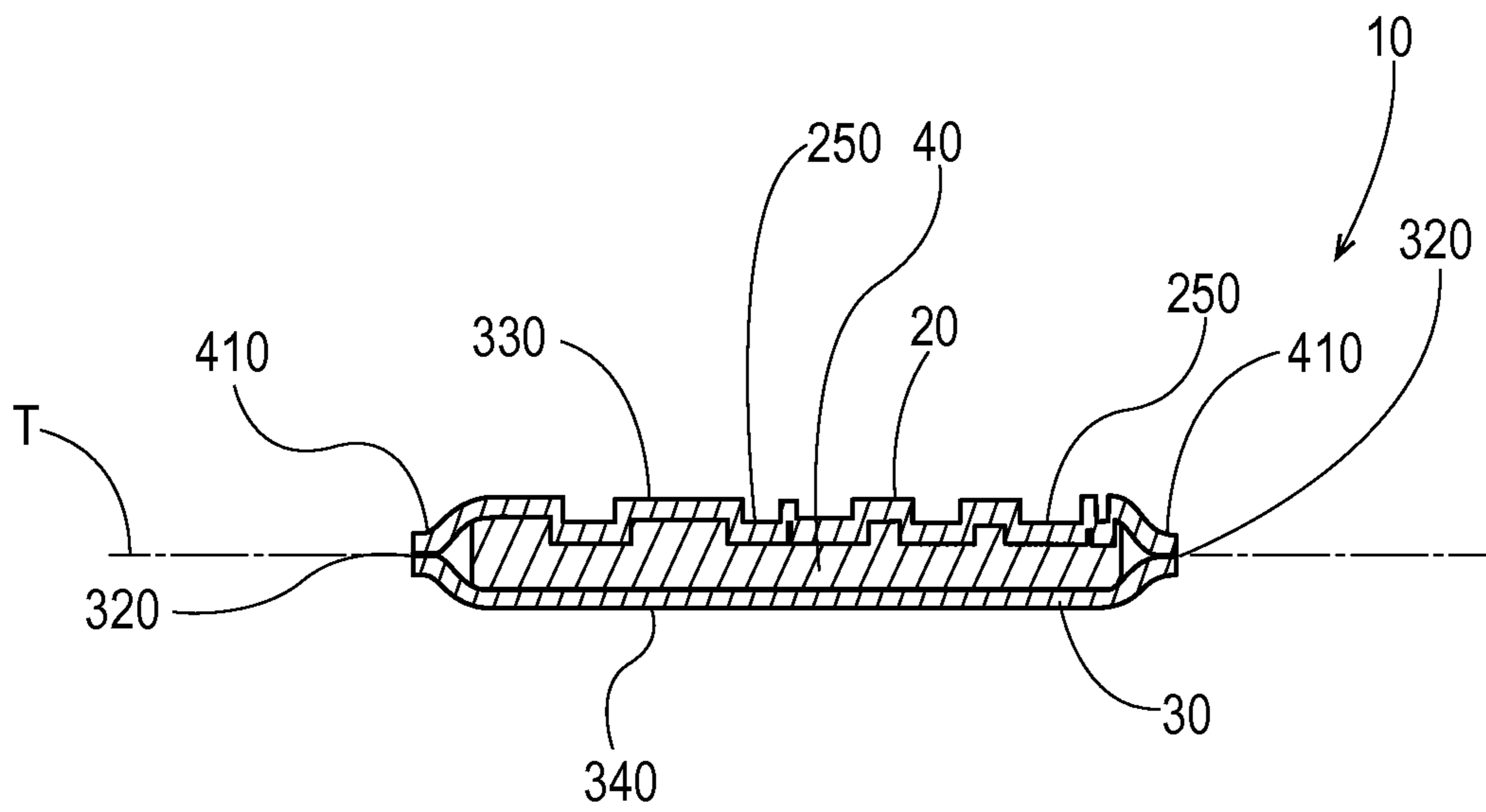

Fig. 11

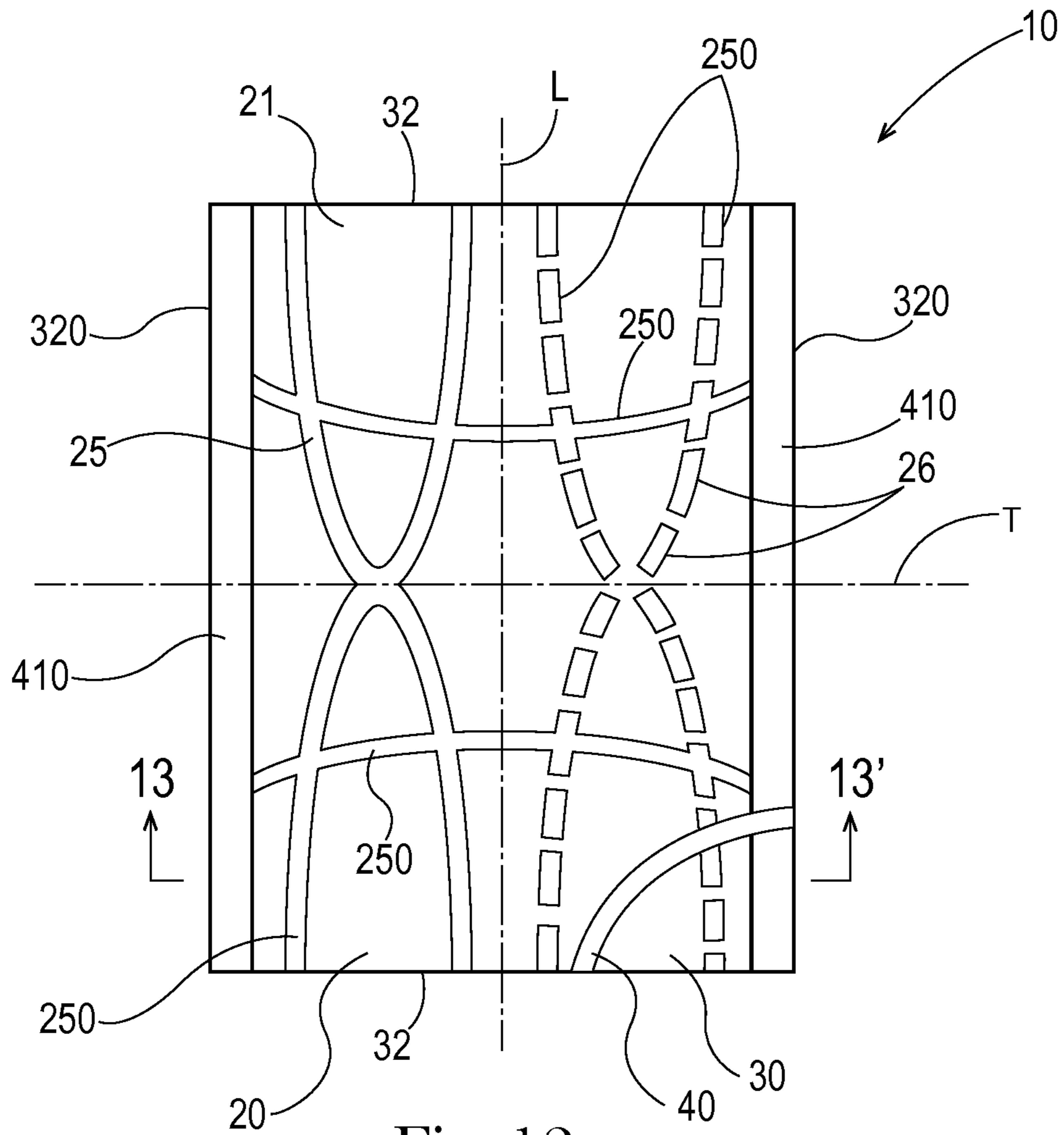

Fig. 12

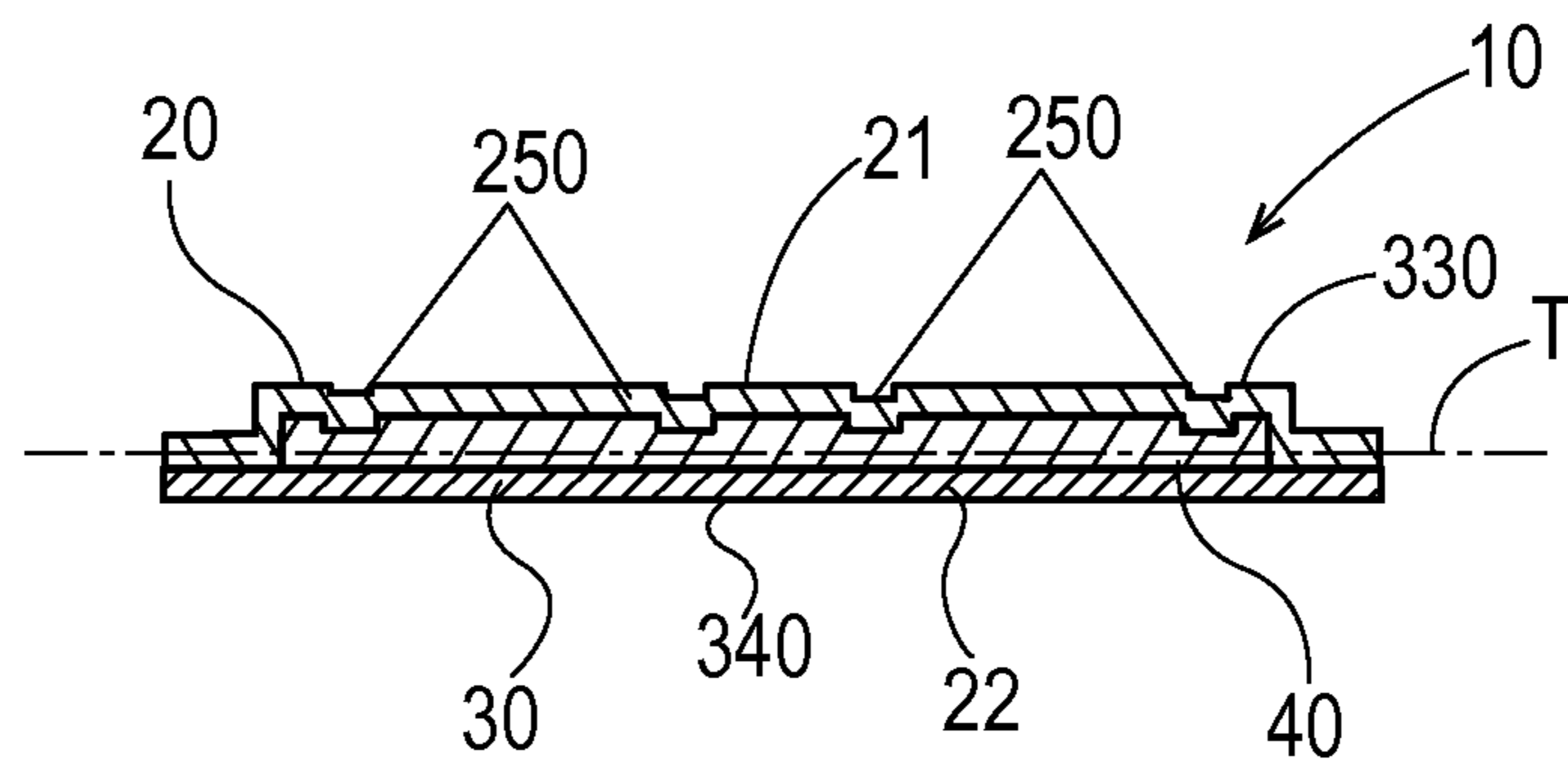

Fig. 13

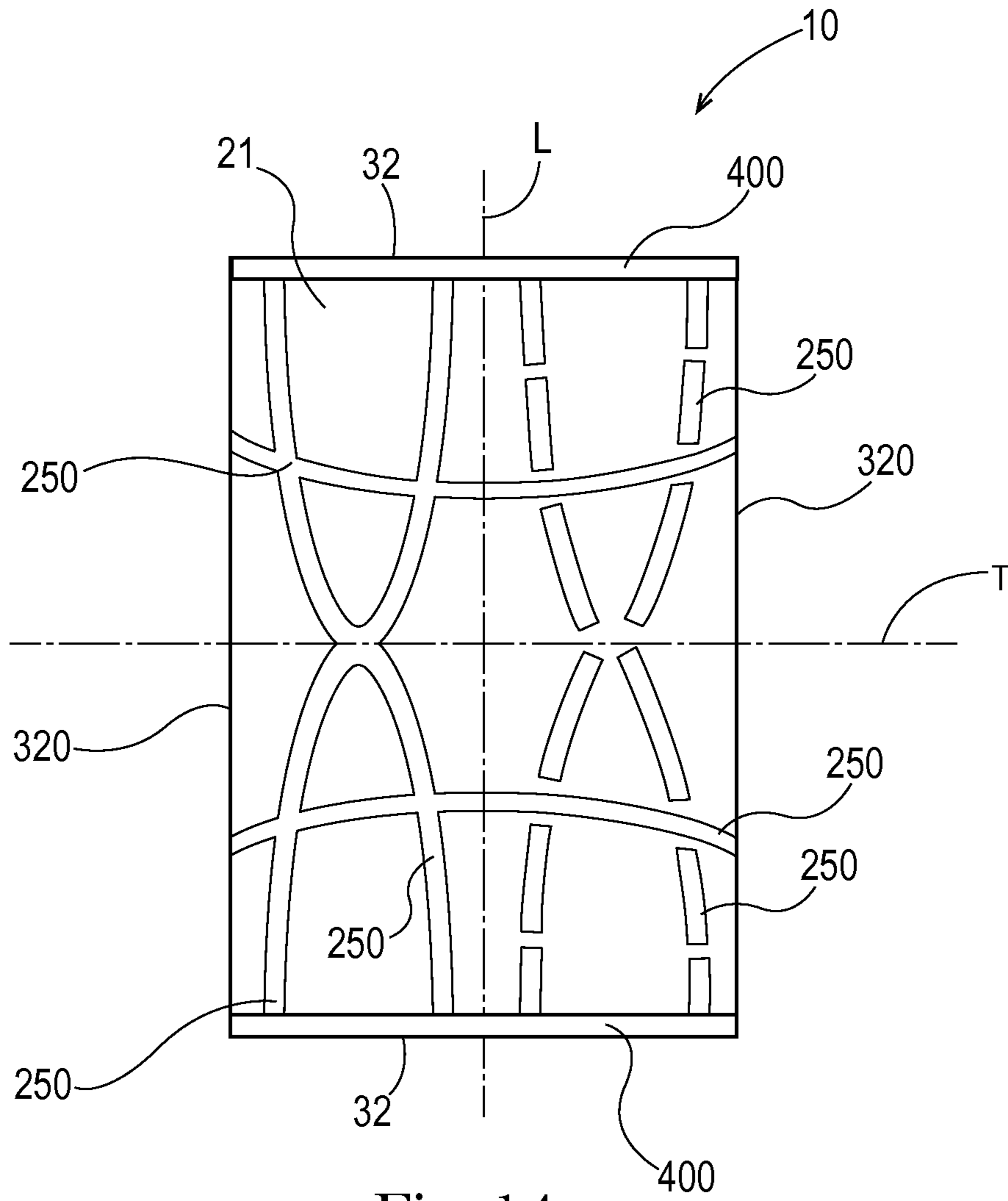

Fig. 14

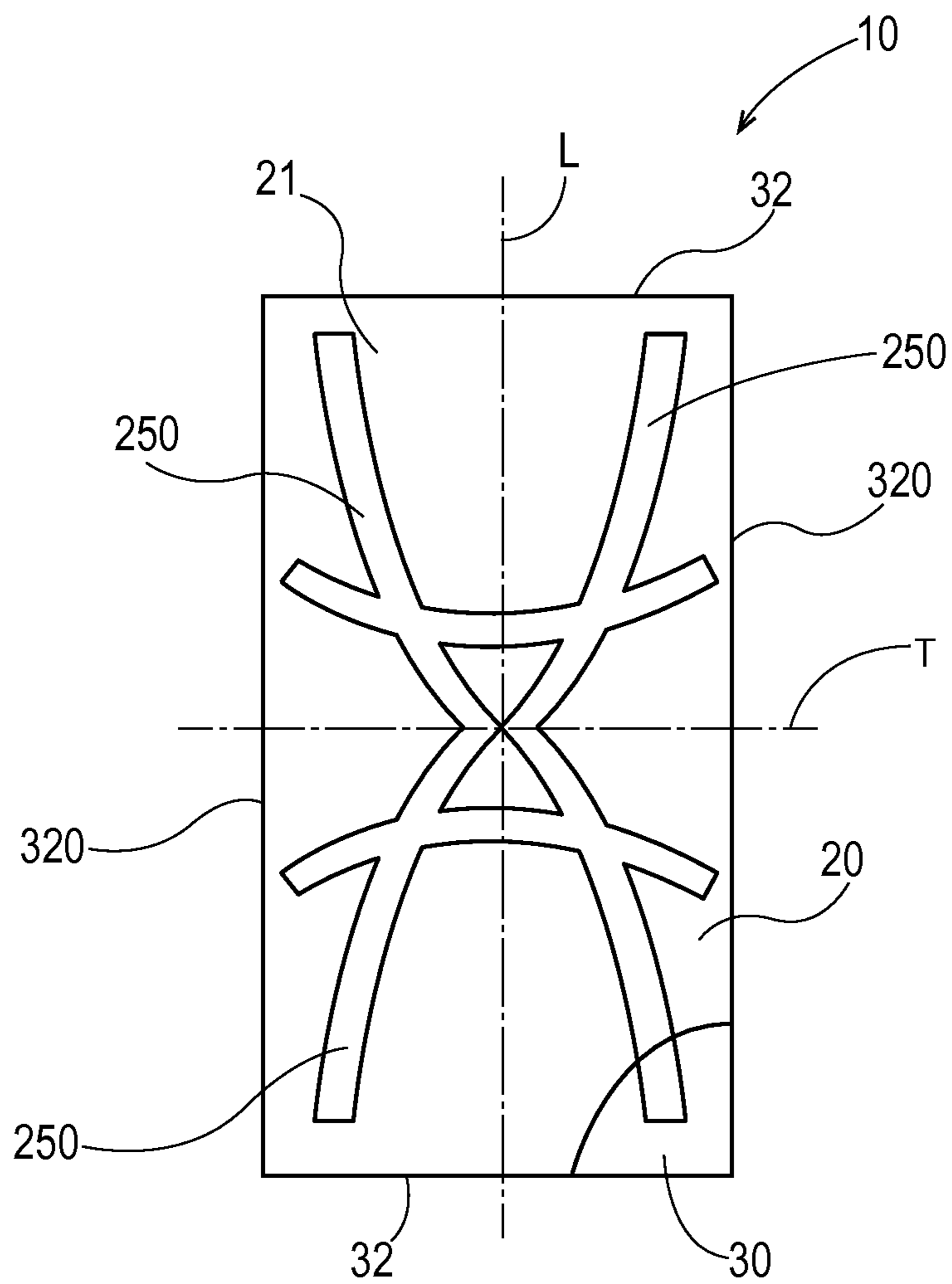

Fig. 15

1**MULTILAYERED CLEANING WIPE**

FIELD OF THE INVENTION

Disposable premoistened multilayered cleaning wipes.

BACKGROUND OF THE INVENTION

People come into contact with many surfaces in their normal everyday lives. The propensity for surfaces to harbor viruses, bacteria, dust, dander, soil, grease, hair, and like materials is well known. As people come into contact with surfaces as they move about, they are exposed to these nefarious materials. Exposure to viruses and bacteria can result in illness. Exposure to dust, dander, and pet hair can cause respiratory distress. Exposure to soil and grease can result in stained clothing. As such, devices for cleaning surfaces are desirable.

One common device provided to consumers for cleaning surfaces is a premoistened cleaning wipe. Such wipes are commonly single layers of a nonwoven fibrous material, the fibrous material being cellulosic or polyolefin material. One limitation to such simple common wipes is that the wipe has only one kind of texture and that texture is presumed by marketers to be efficacious on all kinds of surfaces for all kinds of materials deposited on such surfaces. Further, such simple common wipes tend to lack sufficiently rigidity in use and ball-up during use and can tend to be non-uniformly wetted with cleaning composition.

In reality, the texture of surfaces and the types of materials deposited on such surfaces vary widely. For instance, the texture of the surface of a sofa is vastly different from a countertop surface. The type of cleaning needed to clean the crumbs and hair from a textile at the crease between decorative cording on a sofa and the body of a cushion is wildly different from the type of cleaning needed to clean a hard countertop surface or the body of a textile cushion. Similarly, hair and dust have properties that are largely different from soil.

In view of the wide variety of surfaces that need cleaning and the types of detritus found on surfaces, it is desirable to provide a wipe having particular features that are adapted to clean a wide variety of surfaces and detritus. With these needs in mind, there is a continuing unaddressed need for a disposable premoistened multilayered cleaning wipe having features adapted to clean a wide variety of surfaces and detritus.

SUMMARY OF THE INVENTION

A premoistened cleaning wipe comprising: a liquid permeable first layer joined in facing relationship to a liquid permeable second layer, wherein the liquid permeable first layer comprises a nonwoven and the second layer comprises a substrate and a layer of netting material bonded to the substrate; a core disposed between the first layer and the second layer; and a free liquid cleaning composition comprising between about 0.001% to about 10% by weight of the liquid cleaning composition of surfactant, the cleaning composition releasably absorbed in the core.

BRIEF DESCRIPTION OF THE DRAWINGS

FIG. 1 is a cross sectional view of a wipe taken along the longitudinal axis as marked 1-1' in the plan view of FIG. 5.

FIG. 2 is a plan view of a portion of a first layer.

FIG. 3A is profile view of a portion of an abrasive layer.

2

FIG. 3B is perspective view of a portion of an abrasive layer.

FIG. 4 is a plan view of the wipe shown in FIG. 1 having colored regions.

FIG. 5 is a plan view of the wipe shown in FIG. 1 without colored regions.

FIG. 6 is cross sectional view of a wipe cut along the longitudinal axis.

FIG. 7 is a cross sectional view of a wipe taken across the longitudinal axis.

FIG. 8 is a side view of a wipe taken in line with the longitudinal axis.

FIG. 9 is a plan view of a wipe having channels and colored regions.

FIG. 10 is a plan view of a wipe having channels.

FIG. 11 is a cross sectional view of the wipe shown in FIG. 10 marked 11-11'.

FIG. 12 is a plan view of a wipe having channels.

FIG. 13 is a cross sectional view of a wipe taken along the longitudinal axis as marked 13-13' in the plan view of FIG. 12.

FIG. 14 is a plan view of a wipe.

FIG. 15 is a plan view of a wipe.

DETAILED DESCRIPTION OF THE INVENTION

As used herein, the term "joined" refers to the condition where a first member is attached, or connected, to a second member either directly; or indirectly, where the first member is attached, or connected, to an intermediate member which in turn is attached, or connected, to the second member either directly; or indirectly.

Cleaning wipes can be practical for consumers to use for cleaning a variety of surfaces found throughout the household. For example, it can be desirable for a consumer to use a wipe to clean counter-top surfaces, upholstery, curtains, furniture surfaces, and the like. In use, the consumer can grasp the wipe and wipe the surface. If the wipe contains a cleaning composition, the process of wiping the surface can expel at least some of the cleaning composition onto the surface. The cleaning composition can contain substances, including surfactants, to help remove soil from the surface being cleaned. As the consumer rubs the wipe against the surface to be cleaned, the wipe can lift soil from the surface being cleaned and contain the soil in the core of the wipe or on the surface of the wipe.

A wipe 10 is shown in FIG. 1. As shown in FIG. 1, the wipe 10 can comprise a liquid permeable first layer 20 joined to a liquid permeable second layer 30. The first layer 20 and second layer 30 can be in a facing relationship with one another. The first layer 20 and second layer 30 can individually be generally planar webs of material or materials, each having a first surface 21 and second surface 22 opposing the first surface. The wipe 10 can have a first side 330 and an opposing second side 340. A cleaning composition can be releasably absorbed into one or more of the first layer 20, second layer 30, and a core, if present. A cleaning composition can be releasably absorbed into the interstitial spaces between fibers of one or more of the first layer 20, second layer 30, and a core, if present. A cleaning composition can be releasably absorbed into the interstitial spaces between fibers of a material selected from the group consisting of the first layer 20, second layer 30, and the core, and combinations thereof.

A core 40 can be between the first layer 20 and the second layer 30. Within the core 40, a cleaning composition can be releasably absorbed. A cleaning composition can be releas-

ably absorbed in a material selected from the group consisting of the first layer, the core, the second, and combinations thereof. A core **40** need not be present and the cleaning composition can be releasably absorbed in one or both of the first layer **20** and second layer **30**.

First Layer

The first layer **20** can be liquid permeable. That is, the first layer **20** can provide for thru-transport of cleaning composition from a core **40** to the first surface **21** of the first layer **20**. Once the cleaning composition is on the first surface **21** of the first layer **20** or in the first layer **20**, the cleaning composition can be delivered to the surface being cleaned.

The first layer **20** can be superimposed over the core **40**. In one embodiment, the first layer **20** is associated with the core **40** by spray-gluing the first layer **20** to the surface of the core **40**. In another embodiment, the core **40** can be loosely enrobed by the first layer **20** and second layer **30** without any points of attachment to one or both of the first layer **20** and second layer **30**. The first layer **20** can be joined to the core **40** using any technique known in the art for joining webs of material, including, but not limited to, ultrasonic bonding and thermal bonding. It can be practical to provide a thermally embossed pattern on the first layer **20** of the wipe **10** to provide for bonding between the first layer **20** and the core **40**.

The first layer **20** can be a material that is compliant and soft feeling. A suitable first layer **20** can be manufactured from a wide range of materials such as polymeric materials, formed thermoplastic films, apertured plastic films, porous films, aperture formed films, reticulated foams, natural fibers (e.g., wood or cotton fibers), woven and non-woven synthetic fibers (e.g., polyester or polypropylene fibers) or from a combination of natural and synthetic fibers. The first layer **20** can be a nonwoven comprising polyolefin fibers. A soft compliant first layer **20** can provide for a pleasant interface between the wipe **10** and the user's hand during use of the wipe **10**.

Apertured formed films can be used for the first layer **20** since they are pervious to the cleaning composition and can be non-absorbent and hydrophobic. A surface of a formed film which is in contact with the surface being cleaned can remain relatively dry if the formed film is or is rendered to be hydrophobic. Moreover, apertured formed films are thought to capture and retain lint, fibrous matter such as pet hair, and the like, from the surface being treated, thereby further enhancing the cleaning benefits afforded by the wipe **10**. Suitable apertured formed films are described in U.S. Pat. No. 3,929,135, entitled "Absorptive Structure Having Tapered Capillaries", issued to Thompson on December 30, 1975; U.S. Pat. No. 4,324,246, entitled "Disposable Absorbent Article Having A Stain Resistant Coversheet", issued to Mullane and Smith on Apr. 13, 1982; U.S. Pat. No. 4,342,314, entitled "Resilient Plastic Web Exhibiting Fiber-Like Properties", issued to Radel and Thompson on Aug. 3, 1982; and U.S. Pat. No. 4,463,045, entitled "Macroscopically Expanded Three-Dimensional Plastic Web Exhibiting Non-Glossy Visible Surface and Cloth-Like Tactile Impression", issued to Ahr, Louis, Mullane and Ouellette on Jul. 31, 1984; U.S. Pat. No. 4,637,819 issued to Ouellette, Alcombright & Curro on Jan. 20, 1987; U.S. Pat. No. 4,609,518 issued to Curro, Baird, Gerth, Vernon & Linman on Sep. 2, 1986; U.S. Pat. No. 4,629,642 issued to Kemstock on Dec. 16, 1986; and EPO Pat. No. 0,16,807 of Osborn published Aug. 30, 1989. A suitable apertured formed film can be a 25 gram per square meter polyethylene vacuum formed film sold as product ID PT02 by Clopay.

The apertures in such a first layer **20** may be of uniform size or can vary in size, as disclosed in the foregoing published documents, which can be referred to for technical details,

manufacturing methods, and the like. Such apertures may also vary in diameter in the manner of so-called "tapered capillaries". Such formed-film cover-sheets with tapered capillary apertures can be situated over the core **40** such that the smaller end of the capillaries face the core **40** and the larger end of the capillary faces outward. The capillary apertures can provide for transport of the spent cleaning composition from the surface being cleaned to the core **40**. Apertures in the formed film first layer **20** can have diameters in the range of from 0.1 mm to 1 mm, or as disclosed in the aforesaid patent references.

The first layer **20** may comprise a plurality of first apertures passing through the first layer **20** and a plurality of second apertures passing through first layer **20**. The first apertures can be larger than the second apertures. Each of the first apertures can have an open area between about 0.007 mm² to about 0.8 mm². Each of the second apertures can have an open area between about 0.8 mm² and about 12 mm². Without being bound by theory, it is thought that by providing second apertures of such size that soil that is lifted from the surface being wiped can be transported through the second apertures to the core **40** and be visible on the core **40** when the user inspects the wipe **10** after use. The smaller first apertures can provide for fluid transport through the first layer **20** both when the cleaning composition is expelled from the wipe **10** and retrieved by the wipe **10** from the surface being cleaned during use. Further, a combination of smaller and larger apertures can be practical for providing for adequate fluid transport through the first layer yet still feel dry to the touch when the user uses her hand to hold the wipe **10** to rub the surface being cleaned.

The first layer **20** can be hydrophobic. However, if desired in one embodiment, the outer and/or inner surfaces of the first layer **20** can be made hydrophilic by treatment with a surfactant which is substantially evenly and completely distributed throughout the surface of the first layer **20**. This can be accomplished by any of the common techniques well known to those skilled in the art. For example, the surfactant can be applied to the first layer **20** by spraying, by padding, or by the use of transfer rolls. Further, the surfactant can be incorporated into the polymeric materials of a formed film first layer **20**. Such methods are disclosed in U.S. Pat. No. 5,009,653.

The first layer **20** can be a laminate of an apertured formed film as described previously and a nonwoven. The nonwoven can be made of one or more types of fibers such as those selected from the group consisting of polyester, polyethylene, polypropylene, bi-component fibers, wood, cotton, rayon, and combinations thereof. The nonwoven can be formed by known nonwoven extrusion processes such as those selected from the group consisting of melt blowing, spun bonding, carding, and combinations thereof. The nonwoven can be extensible, elastic, or inelastic. The nonwoven web can comprise polyolefin fibers. The polyolefin fibers can be selected from the group consisting of polypropylene, polyethylene, ethylene copolymers, propylene copolymers, and butane copolymers. The nonwoven can be a 28 gram per square meter 50/50 polyethylene sheath/polypropylene core bi-component fiber. The nonwoven can be a laminate of a plurality of nonwoven webs. For instance, the nonwoven can comprise a first layer of spun bonded polypropylene having a basis weight from about 6.7 grams per square meter to about 271 grams per square meter, a layer of melt blown polypropylene having a basis weight from about 6.7 to about 271 grams per square meter, a layer of melt blown polypropylene having a basis weight from about 6.7 grams per square meter to about 136 grams per square meter, and a second layer of spun bonded polypropylene having a basis weight from about 6.7

5

grams per square meter to about 271 grams per square meter. The nonwoven can be a spun bonded nonwoven or a melt blown nonwoven having a basis weight from about 6.7 grams per square meter to about 339 grams per square meter. The nonwoven can be a 28 gram per square meter 50/50 polyethylene sheath/polypropylene core bi-component fiber. The nonwoven fibers can be joined by bonding to form a coherent web structure. The bonding can be selected from the group consisting of chemical bonding, thermobonding, point calendaring, hydroentangling, and needle punching.

The nonwoven can be joined to an apertured formed film using techniques known in the art including melt bonding, chemical bonding, adhesive bonding, ultrasonic bonding, and the like.

A laminate of a nonwoven and apertured formed film can be formed as described in U.S. Pat. No. 5,628,097, issued to Benson and Curro, on May 13, 1997, to form the first layer **20**. For such a laminate structure, the first layer **20** may comprise a plurality of first apertures **200** passing through the first layer **20** (i.e. both the apertured formed film **41** and nonwoven **42**) and a plurality of second apertures **210** passing through the apertured formed film **41** but not the nonwoven **42**, as shown in FIG. 2, which is an embodiment of a first layer **20** of the wipe **10**. That is, the nonwoven **42** can be free from the second apertures **210**. The first apertures **200** can be larger than the second apertures. Each of the second apertures **210** can have an open area between about 0.007 mm² to about 0.8 mm². Each of the first apertures **200** can have an open area between about 0.8 mm² and about 12 mm². Without being bound by theory, it is thought that by providing first apertures **200** of such size that soil that is lifted from the surface being wiped can be transported through the first apertures **200** to the core **40** and be visible on the core **40** when the user inspects the wipe after use. The second apertures **210**, which can be smaller than the first apertures **200**, can provide for fluid transport through the first layer **20** both when the cleaning composition is expelled from the wipe **10** and retrieved by the wipe **10** during use. Further, a combination of smaller and larger apertures can be practical for providing for adequate fluid transport through the first layer yet still feel dry to the touch when the user uses her hand to rub the surface being cleaned with the wipe **10**. The first apertures **200** can be sized and dimensioned such that a user is able to view the core **40** through such apertures.

The first layer **20** can comprise an apertured film. For instance, the first layer **20** can be a 25 gram per square meter polyethylene vacuum formed film sold as product ID PT02 by Clopay. The first layer **20** can comprise a laminate of a film and a nonwoven having apertures through the laminate. The first layer **20** can comprise a laminate of an apertured film and a nonwoven. The first layer **20** can comprise a laminate of an apertured film having first apertures **200** and a nonwoven, the apertured film and nonwoven both having first apertures **200** there through. The first layer **20** can comprise a fibrous material, such as a fibrous nonwoven comprising polyolefin fibers. The first layer **20** can be an apertured fibrous material, such as an apertured fibrous nonwoven comprising polyolefin fibers.

The first layer **20** can be a spun bond nonwoven. The spun bond nonwoven can be apertured. The apertures can have an open area greater than about 0.1 mm². The fibers of the spun bond nonwoven can be bicomponent continuous fibers. The fibers of the spun bond can be blended continuous fibers. The fibers can be extruded and bonded in a single step. For bicomponent spun bond fibers, the components of the fiber can have two different melting points. For blended fibers, the component fibers of the blend can have two different melting points.

6

The spun bond nonwoven can have a basis weight of between about 15 grams per square meter to about 80 grams per square meter.

The first layer **20** can be a coherent extensible nonwoven that is a thermally bonded spun bond nonwoven web of randomly arranged substantially continuous fibers. The spun bond nonwoven can be manufactured using a conventional spun bond process. Molten polymer is extruded in continuous filaments that are subsequently quenched, attenuated by a high velocity fluid, and collected in a random arrangement on a collecting surface. After collection of the fibers, thermal, chemical, or mechanical bonding can be performed on the fiber to form the spun bond nonwoven. The first layer can be a spun bond nonwoven referred to as SOFSPAN **200** available from Fiberweb.

Core

The core **40** can be a material that can releasably absorb a cleaning composition. In practice, the voids within the core **40** can act as a reservoir for the cleaning composition, the cleaning composition being stored within the capillaries within the core **40**. The core **40** can be a fibrous material in which the capillaries are provided by the interstitial spaces between the fibers of the core **40**. The core **40** can be an open celled foam in which the capillaries are provided by the interconnected pores within the foam. The core **40** can comprise a nonwoven. An economical core **40** can be provided by a nonwoven comprising polyolefin fibers.

The core **40** can comprise a layer of cellulosic material. The core can comprise an 80 gram per square meter nonwoven of bicomponent fibers, the bicomponent fibers comprising a polyethylene sheath and a polyethylene terephthalate core having a loft of about 2.5 mm. The bicomponent fibers can provide for structural integrity of the core **40** when bonded. Having an appreciable weight fraction of the core **40** made of cellulose can be economical and technically sound since cellulose is known to highly absorbent.

The core **40** can comprise a multi bonded air-laid core. The core **40** can comprise a multi bonded air-laid core comprising about 15% by weight bicomponent fibers having a polyethylene sheath and polyethylene terephthalate core, about 2.5% by weight latex, about 82% by weight pulp, and a basis weight of about 135 grams per square meter. The bicomponent fibers can provide for structural stability and rigidity of the core **40** and the latex can aid in bonding the different components of the core **40** together.

The core **40** can comprise a thermally bonded air-laid core. The core **40** can comprise a thermally bonded air-laid core comprising about 18% by weight bicomponent fibers having a polyethylene sheath and polypropylene core and about 82% pulp.

The core **40** can comprise a laminate of an 80 gram per square meter nonwoven of bicomponent fibers, the bicomponent fibers comprising a polyethylene sheath and a polyethylene terephthalate core having a loft of about 2.5 mm and two layers of a multi bonded air-laid core comprising about 15% by weight bicomponent fibers having a polyethylene sheath and polyethylene terephthalate core, about 2.5% by weight latex, about 82% by weight pulp, and a basis weight of about 135 grams per square meter. The core **40** can be a single layer thermally bonded pulp core that is 90% by weight pulp and 10% by weight bicomponent polyethylene/polypropylene fibers.

The core **40** can comprise open celled foam. For instance, the core **40** can comprise open celled foam formed from a high internal phase emulsion, such as the open celled foam described in U.S. Pat. No. 5,387,207, issued to Dyer, DesMaraais, LaVon, Stone, Taylor, and Young, on Feb. 7, 1995. Open

celled foams can be desirable since they can provide for a large storage volume of cleaning composition relative to the mass of the core **40**.

The core **40** can comprise a material selected from the group consisting of polyolefin fibers, cellulose fibers, rayon, open celled foam, and combinations thereof.

The functions of the core **40**, if present, are to store a cleaning composition prior to use, dispense cleaning composition when the wipe **10** is used to clean a surface, reabsorb spent cleaning composition after cleaning, and retain soil that has been removed by the cleaning effort. The core can have a storage volume of about 19 ml. The core can have a storage volume of between about 5 mL and about 30 mL in an uncompressed state. The core can have a storage volume of between about 12 mL and about 25 mL in an uncompressed state. The core can have a storage volume of between about 16 mL and about 25 mL in an uncompressed state.

Second Layer

The second layer **30** can be liquid permeable. That is, the second layer **30** can provide for thru-transport of liquid cleaning composition from a core **40** to the second surface **22** of the second layer **30**. The second layer **30** can be superimposed under the core **40** so that the core **40** is between the first layer **20** and second layer **30**. In one embodiment, the second layer **30** can be associated with the core **40** by spray-gluing the second layer **30** to the surface of the core **40**. In another embodiment, the core **40** is loosely enrobed by the first layer **20** and second layer **30** without any points of attachment. The second layer **30** can be joined to the core **40** using any technique known in the art for joining webs of material, including, but not limited to, ultrasonic bonding and thermal bonding.

The second layer **30** can be a material that is compliant and soft feeling. The second layer **30** can be any of the materials as described previously as being suitable for the first layer **30**. It can also be practical for the second layer **30** to be an abrasive layer.

Abrasive Layer

The wipe **10** can have an abrasive layer. The abrasive layer of the wipe **10** can be the second layer **30** of the wipe **10**. Arranged as such, the first layer **20** can provide for a soft compliant wiping surface and the abrasive layer can be on the side of the core **40** opposite the first layer **20**. In a simple construction, the wipe **10** can have 3 layers, a first layer **20**, an abrasive layer being the second layer **30**, and a core **40** disposed between the abrasive layer and first layer **20**.

It is contemplated that the second layer **30** can be positioned such that the second layer **30** is between the abrasive layer and the core **40**. For instance, as shown in FIG. 1, the second layer **30** can be the abrasive layer of the wipe **10**. If the abrasive layer is the second layer **30**, other layers of material may be between the abrasive layer and core **40**, but are not necessarily needed.

If other layers are provided between the abrasive layer and the core **40**, such other layers can have other functional attributes and one or more of those layers can be considered to be the second layer **30** as described herein.

The abrasive layer can be liquid permeable. That is, the abrasive layer can provide for thru-transport of liquid from a core **40** from the first surface **21** to the second surface **22** of the abrasive layer. The abrasive layer can be superimposed over the core **40**. In one embodiment, the abrasive layer is associated with the core **40** by spray-gluing the abrasive layer to the surface of the core **40**. In another embodiment, the core **40** is loosely enrobed by the first layer **20** and abrasive layer without any points of attachment. The abrasive layer can be bonded to the core **40** using any technique known in the art for

joining webs of material, including, but not limited to, ultrasonic bonding and thermal bonding.

A suitable abrasive layer can be manufactured from a wide range of materials such as polymeric materials, formed thermoplastic films, apertured plastic films, porous films, aperture formed films, reticulated foams, natural fibers (e.g., wood or cotton fibers), woven and non-woven synthetic fibers (e.g., polyester or polypropylene fibers) or from a combination of natural and synthetic fibers.

The abrasive layer can be a material that provides an abrasive surface of the wipe **10**. In use, an abrasive layer that is rough can help to dislodge soil from the surface being cleaned and can help pick up loose fibers such as dust, lint, dander, pet hair, and the like from the surface being cleaned. Further, an abrasive layer may help fluff up the fibers in textiles that are being cleaned thereby allowing for better application of the cleaning composition to the textile surface being cleaned.

The abrasive layer can comprise a net material. The net material can be a net comprised of at least two sets of strands wherein each set of strands crosses and interconnects another set of strands at a substantially fixed angle wherein strands in each set extend along a respective direction and are in substantially co-planar, spaced-apart relationship. The net material can be polypropylene or other suitably durable polyolefin material. The abrasive layer can be a material such as that sold under the trade name DELNET, by Delstar Technologies, Inc., Middletown, Del.

The abrasive layer can comprise a composite material **99** such as any of the materials described in U.S. Pat. No. 7,917,985 issued to Dorsey et al. on Apr. 5, 2011.

For instance, as shown in FIGS. 3A and 3B, the abrasive layer **50** can comprise a net material **100** comprising at least two sets of strands **110** wherein each set of strands **110** crosses and interconnects another set of strands **110** at a substantially fixed angle wherein strands **110** in each set of strands **110** extend along a respective direction and are in substantially co-planar, spaced-apart relationship that is bonded to a substrate **120** wherein a plurality of the strands **110** are broken forming raised whiskers **130** that extend away from the substrate **120**, as shown in FIGS. 3A and 3B. The abrasive layer **50** can be positioned to form the wipe **10** such that the whiskers **130** extend away from the core **40**. That is, the second side of the wipe **10** can have whiskers. As the wipe **10** can be constructed, the substrate **120** can be between the net material **100** and the core **40**. Together, the net material **100** and substrate **120** can form an outer layer of the wipe **10** that is the second side of the wipe **10**.

The net material **100** can be a 51 grams per square meter polypropylene net (style number R0412-10PR) made by Delstar Technologies, Inc., Middletown, Del., and sold under the trade name DELNET. The net material **100** can be polypropylene net (style number RC0707-24P) made by Delstar Technologies, Inc., Middletown, Del., and sold under the trade name DELNET. The net material can have 40 strands per inch in the machine direction and 13 strands per inch in the cross direction that are bonded to one another, together forming the two sets of strands **110**. The net material can be polypropylene fine square structure net referred to as PF40 and sold by Smith and Nephew Extruded Films, East Yorkshire, England. The net material **100** can be thermally bonded to one or more layers of a substrate **120** to form composite **99**.

The substrate **120** can be a nonwoven or woven material. The substrate can be one or more layers of 60 grams per square meter 50% polypropylene 50% rayon spun laced non-woven fabric. The substrate **120** can be a 60 gram per square meter polypropylene polyethylene copolymer. The substrate **120** can be SOFSPAN **120**, available from Fiberweb. The

composite **99** can be stressed to break a plurality of the strands **110** to form the whiskers **130**. The stress can be provided, for instance, by a ring rolling process as described in U.S. Pat. No. 7,917,985 issued to Dorsey et al. on Apr. 5, 2011.

In one embodiment of the wipe **10**, it can be practical for the abrasive layer **50** to be translucent. Such translucency can provide the user the ability to examine the second side of the wipe and observe that a colored second layer **30** is between the abrasive layer **50** and the core **40**. A translucent abrasive layer **50** can be provided by an uncolored or lightly colored abrasive layer.

Free Liquid Cleaning Composition

To aid in cleaning, the wipe **10** can be provided with a free liquid cleaning composition. The free liquid cleaning composition can be releasably absorbed in the core **40**. That is, the volume of the free liquid cleaning composition is held within the voids of the core **40** by capillary forces. For example, the free liquid cleaning composition can be held by surface tension within the interstitial spaces between fibers or within the cells of an open celled foam forming the core **40**. The free liquid cleaning composition can be expelled from the core **40** by compressing the core **40**. The core **40** can reabsorb spent cleaning composition into voids within the core **40** by capillary forces. The capillary forces can act to draw spent cleaning composition through the first layer **20** to the core **40**.

The free liquid cleaning composition is an unencapsulated liquid cleaning composition. The free liquid cleaning composition can be releasably absorbed in a material selected from the group consisting of first layer **20**, second layer **30**, core **40**, and combinations thereof. The free liquid cleaning composition can be releasably absorbed in constituent fibers of a material selected from the group consisting of first layer **20**, second layer **30**, core **40**, and combinations thereof.

One practical formulation of the cleaning composition is set forth in Table 1.

TABLE 1

Cleaning composition formulation.		
Ingredient	% Active by Weight	Function
Distilled water	Quantity sufficient to balance to 100%	Solvent
Sodium lauryl sulfate	0.90	Anionic surfactant
C12/14 amine oxide	0.30	Cationic surfactant
Glycol Ether PPh	1.50	Solvent
Citric Acid 50%	Trace as needed to target pH of 7	pH adjustment, builder
Korolone B-119	0.01	Preservative
Perfume	0.02	Perfume
Dow Corning DC 2310	0.02	Antifoam

The cleaning composition can comprise between about 0.001% to about 10% by weight of the liquid cleaning composition of surfactant. The cleaning composition can comprise between about 0.1% to about 5% by weight of the liquid cleaning composition of surfactant. The cleaning composition can comprise between about 0.1% to about 4% by weight of the liquid cleaning composition of surfactant. The cleaning composition can comprise between about 0.1% to about 3% by weight of the liquid cleaning composition of surfactant. The cleaning composition can comprise between about 0.1% to about 2% by weight of the liquid cleaning composition of surfactant. Without being bound by theory, it is thought that lower mass fractions of surfactant might result in less observable residual cleaning composition left on a surface after cleaning. Higher mass fractions of surfactant might result in

ringing and spotting from a locally heavy application of the cleaning composition to the surface being cleaned.

The cleaning composition can comprise 0.001% to 0.1% by weight of an antifoam compound. A non-limiting example of an antifoam compound is Dow Corning DC 2310.

The cleaning wipe **10** can comprise between about 5 g to about 40 g of cleaning composition. The cleaning wipe **10** can comprise between about 15 g to about 30 g of cleaning composition.

Colored Regions

The wipe **10** as contemplated herein can have two sides, each having a different function. For instance, one side of the wipe can have a soft compliant surface for wiping a surface or fabric to remove light soiling, dust, and lint and the other side can have an abrasive surface that can dislodge agglomerations of soil or alter the surface of a textile so that a cleaning composition can be effectively delivered to and retrieved from the textile.

One problem associated with a wipe **10** having two sides with each side providing a different function is that the difference between the two sides may not be immediately apparent to the user. This can be especially true if the user is looking at only one side of the wipe **10**. Surprisingly, color signals that are visible to the user when looking at only one side of the wipe **10** can be used to signal the user that the opposite side of the wipe **10** has a different function.

A premoistened wipe **10** having a longitudinal axis L is shown in FIGS. 4 and 5. The wipe **10** can have a liquid permeable first layer **20** joined to a liquid permeable second layer **30**. The first layer **20** and the second layer **30** can be in a facing relationship with one another. By facing relationship, it is meant that the two components rest generally flat relative to one another so that one planar surface of one component faces a planar surface of the other component, like a floor mat rests on the floor. Two components can be in a facing relationship yet still have other components positioned between the two components that are in a facing relationship, for instance like a sandwich that has a slice cheese positioned between two slices of bread that are in a facing relationship.

The wipe **10** can have a first colored region **300** disposed on the longitudinal axis L between a pair of opposing second colored regions **310**. Each of the second colored regions **310** extends laterally beyond the first colored region **300** to a respective transverse edge **320**. Laterally is taken to be in a direction orthogonally away from the longitudinal axis L. A core **40** can be disposed between the first layer **20** and the second layer **30**. The first colored region **300** and the second colored region **310** can differ in color. Without being bound by theory, it is thought that by having the second colored regions **310** disposed along the transverse edges **320**, the user will be led to more closely inspect the opposing side of the wipe **10** to learn that the opposing side has a different function or characteristic. The contrast in color between the portion of the central part of the wipe **10** along a portion of the longitudinal axis L can lead the consumer to more closely inspect the opposing sides of the wipe **10**.

The second colored regions **310** can be provided in a number of manners. For instance, the second colored region **310** can be provided by the second layer **30**. The second layer **30** can be at least partially visible through the first layer **20** in the second colored regions **310**. Visibility of the second layer through the first layer **20** can be provided for by bonding the second layer **30** and first layer **30** to one another with no other component there between or only a translucent component between the first layer **20** and second layer **30**. For instance, the wipe **10** can be designed so that the core **40** is absent between the first layer **20** and second layer **30** in the second

11

colored regions **310**. The first layer **20** and the second layer **30** can be joined directly to one another so that the first layer **20** and second layer **30** are in direct contact with one another.

The first colored region **300** can be provided for by the constituent color of the first layer **20**. For example, the first layer **20** can have the constituent color of white. Such color can be provided for by a colored first layer **20** with the color being provided for by a material selected from the group consisting of dye, pigment, ink, and combinations thereof. The color of the first layer **20** can be provided for with a pigment such as titanium dioxide.

The first colored region **300** can be provided a color by inkjet printing, printing, gravure printing, flexographic printing, lithographic printing, and screen printing. The first layer **20** can be provided with a color by using pigments and/or dyes. For instance, if the first layer **20** is a fibrous material, the fibers may contain a whitening agent, for example titanium dioxide, that is included in the fibrous material at the time of manufacture of the constituent fibers.

The second colored regions **310** can be provided a color by inkjet printing, printing, gravure printing, flexographic printing, lithographic printing, and screen printing. The second colored regions **310** can be provided by printing on the first layer **20**. Such printing, if present, can be provided for on either or both of the first side **20** or second side **21** of the first layer **20**. The second colored regions **310** can be part of the first layer **20**, the second layer **30**, or another layer of material that when colored is visible from the first side **330** of the wipe **10**.

It can be practical for the first colored region **300** to be part of the first layer **20** and the second colored regions **310** can be part of the second layer **30**. For instance, as shown in FIG. 4, the core **40** is between the first layer **20** and the second layer **30** except in the second colored regions **310**. If the entire second layer **30** is colored, the core **40** can be opaque enough so that core **40** obscures or partially obscures at least a portion of the second layer **30** beneath the core **40** when said first layer **20** is viewed from the first side **330**. That is, the color of the second layer **30** that provides the second colored regions **310** is not visible or at least entirely visible through the combination of the core **40** and first layer **30** in portions away from the second colored regions **310** when the first layer **20** is viewed by an observer. The first layer **20** can be translucent enough such that when joined to the second layer **30**, the color of the second layer **30** is visible through the first layer **20**.

As shown in FIGS. 4 and 5, the first layer **20** and second layer **30** can be joined to one another along each transverse edge **320** and the second layer **30** can be visible through at least a portion of the first layer proximal the transverse edges **320**. The first layer **20** can be an apertured film, and apertured formed film, a nonwoven, woven material, or a composite material of such constituents.

In one embodiment of the wipe **10**, the first layer **20** can form the first side **330** of the wipe **10** and the wipe **10** can have a second side **340** opposing the first side **330** of the wipe **10**. The first side **330** within the first colored region **300** and the second side **340** of the wipe **10** can be measured by a Hunter Reflectance Meter test according to the colors L^* , a^* , and b^* , the L^* , a^* , and b^* values. The first side **330** within the first colored region **300** and the second side **340** of the wipe **10** at a location can differ in color by a magnitude calculated according to the formula $\Delta E = [(L^*_X - L^*_Y)^2 + (a^*_X - a^*_Y)^2 + (b^*_X - b^*_Y)^2]^{1/2}$, wherein ΔE is greater than about 5, or alternatively greater than about 10.

Reflectance color is measured using a Hunter Reflectance Meter test that employs using the Hunter Lab LabScan XE reflectance spectrophotometer obtained from Hunter Associ-

12

ates Laboratory of Reston, Va. A wipe **10** is tested at an ambient temperature between 18.3° C. and 23.9° C. and a relative humidity between 50% and 80%.

The spectrophotometer is set to the CIE Lab color scale and with a D65 illumination. The Observer is set at 10° and the Mode is set at 45/0°. Area View is set to 0.125" and Port Size is set to 0.125". The spectrophotometer is calibrated prior to sample analysis utilizing the black glass and white reference tiles supplied from the vendor with the instrument. Calibration is done according to the manufacturer's instructions as set forth in LabScan XE User's Manual, Manual Version 1.1, August 2001, A60-1010-862. If cleaning is required of the reference tiles or samples, only tissues that do not contain embossing, lotion, or brighteners should be used (e.g., PUFFS tissue).

To help the user detect the presence of the different surfaces of the wipe **10** each having a different function or characteristic, it can be practical to have the first colored region **300** and the second colored region **310**. As shown in FIG. 4, the first layer **20** can form a first side **330** of the wipe **10**. The first colored region **300** and the second colored region **310** can be measured by a Hunter Reflectance Meter test according to the colors L^* , a^* , and b^* , the L^* , a^* , and b^* values being measured from the first side **330**, wherein said first colored region **300** and the second colored region **310** differ in color by a magnitude calculated according to the formula $\Delta E = [(L^*_X - L^*_Y)^2 + (a^*_X - a^*_Y)^2 + (b^*_X - b^*_Y)^2]^{1/2}$, wherein ΔE is greater than about 2. Herein, the 'X' in the equation can represent the first region **300** or the second region **310**. 'Y' in the equation can represent the first region **300** or the second region **310**. 'X' and 'Y' are not to be the same object. In other words, for any particular evaluation of the difference in color, the location of 'X' is not the same as the location of 'Y'.

A difference in color of ΔE greater than about 2 provides a difference in color that can appear distinct to an observer. The greater the ΔE between the color of the first region **300** and the color of the second region **310**, the more readily distinguishable the two colors are. Thereby, the difference in color of the first region **300** and the second region **310** can be readily distinguishable by the user.

The AE between the color of the first region **300** and the second region **310** can be greater than about 3. The AE between the color of the first region **300** and the second region **310** can be greater than about 5. The ΔE between the color of the first region **300** and the second region **310** can be greater than about 10.

The ΔE between the color of the first region **300** and the second region **310** can be greater than about 20. The ΔE between the color of the first region **300** and the second region **310** can be greater than about 30. The ΔE between the color of the first region **300** and the second region **310** can be greater than about 40. The ΔE between the color of the first region **300** and the second region **310** can be greater than about 50. The ΔE between the color of the first region **300** and the second region **310** can be greater than about 60. The difference in color AE between the first region **300** and the second region **310** can be greater than any integer number greater than 2.

By having the difference in color between the first region **300** and second region **310** large enough, the user can be driven to more closely inspect the opposing surfaces of the wipe **10** and learn that the different sides of the wipe **10** can be used for different functions. For instance, in one embodiment it is contemplated that the second side **340** of the wipe **10**, which opposes the first side **330** of the wipe, can have a color that is a shade of the color of the second region **310**. As shown in FIG. 4, the color of the second layer **30**, which would be

visible from the second side **340** of the wipe **10**, can be visible through the first layer **20** in portions of the first layer **20** away from the core **40**. The color of the second layer **30** can be particularly visible on the first side **330** of the wipe **10** where the first layer **20** and second layer **30** are joined to one another, either in direct contact with one another or through one or more intermediate layers between the first layer **20** and the second layer **30**.

In one embodiment, the color of the first region **300** can be such that the L^* value is greater than about 70. Such a color for the first region **300** can be practical such that soil that is lifted from the surface being wiped can be visible on the first layer **20**, thereby providing a visual cue that the wipe **10** was successful at removing soil.

The color of the first region **300** can be such that the L^* value is greater than about 70 and the a^* value is between about -5 and about 5 and a b^* is between about -5 and about 5 . The color of the first region **300** can be such that the L^* value is greater than about 50, which for some types of soils may be light enough for a soil lifted from a surface being treated to be visually apparent on the first layer **20**. The color of the first region **300** can be white. The color white is defined as a color having an L^* value of greater than about 70, an a^* value equal to 0 ± 2 , and a b^* value equal to 0 ± 2 .

The color of the second region **310** can be such that the L^* value is less than about 70. The color of the second region **310** can be such that the L^* value is less than about 65. Such L^* values less than about 70 or less than about 65 may tend to be perceived as relatively dark, as compared to the color of the first region **300** if the color of the first region is relatively light or white.

Wipe

The wipe **10** can have a variety of constructs including any of those discussed previously. In the construction shown in FIG. 1, the first layer **20** and second layer **30** can be joined to one another, for instance by melt bonding, chemical bonding, adhesive bonding, ultrasonic bonding, and the like. The first layer **20** and second layer **30** can be joined to one another along the transverse edges **320**. The transverse edges **320** are spaced apart away from the longitudinal axis L . The transverse edges **320** can be straight lines or nonlinear, for instance a decorative scalloped pattern. The first layer **20**, second layer **30**, and core **40** can be coextensive with one another along the longitudinal axis L , as shown in FIG. 1. The first layer **20**, core **40**, and second layer **30** can be joined together at the longitudinal ends of the wipe **10**, as shown in FIG. 6. In an alternative arrangement, the first layer **20** and second layer **30** can be joined to one another along the transverse edges **320** and along the longitudinal ends to form a pocket in which the core **40** is positioned. In such an arrangement, the first layer **20** and second layer **30** can be longitudinally more extensive than the core **40** so that at the longitudinal ends of the wipe **10**, the core **40** is not between the first layer **20** and second layer **30**. That is, the longitudinal ends/longitudinal edge bonds of the wipe **10** can be free of material from the core **40**. The first layer **20** and second layer **30** can extend longitudinally beyond the core **40** and extend further away from the longitudinal axis L than the core **40**, thereby forming a pouch within which the core **40** is positioned. Arranged as such, the transverse edges **320** can be free of material from the core **40**.

As shown in FIG. 6, the wipe **10** can comprise a pair of longitudinal edge bonds **400** disposed at opposing longitudinal edges of the wipe **10** across the longitudinal axis L . Each longitudinal edge bond **400** can comprise material from the first layer **20**, the core **40**, and the second layer **30**. By having longitudinal edge bonds **400** that include the core **40**, the longitudinal edge bonds **400** can have a greater resistance to

bending as compared to other portions of the wipe **10**, for instance as compared to the transverse edge bonds **410**. The longitudinal edge bonds **400** can have a greater resistance to bending than the transverse edge bonds **410** of the wipe **10**. Having a different resistances to bending between these two parts of the wipe **10** can be beneficial in that the stiffer part can be more suitable for cleaning one type of feature, such as the crease between cording and fabric on a sofa, and the more flexible part can be used to lightly brush a delicate surface, such as the leaf of decorative plant.

Resistance to bending can be measured by separating the relevant bond from the wipe and using a two point bending test with the resistance to bending quantified as the force required to deflect the free end of the beam of bond material 10% of the length of the beam of bond material.

Similarly, the longitudinal edge bonds **400** can be thicker than the transverse edge bonds **410**, the thickness being measured orthogonal to the longitudinal axis L and out of plane with respect to the first layer **20** and the second layer **30**. This difference in thickness can provide for the availability of the wipe **10** to fit into different size cracks, crevices, and creases.

Stiff longitudinal edge bonds **400** can be useful for cleaning narrow creases and folds in surfaces. If the longitudinal edge bonds **400** are floppy, as might be the case if only the first layer **20** and second layer **30** are bonded to one another to enclose the core **40**, it might be difficult for the user to slip the wipe **10** edgewise into a narrow crease, crevice, or fold. It is thought that the stiff longitudinal edge bonds **400** can be useful for cleaning the crease between the sole of a dress shoe and the body of the shoe. The stiff longitudinal edge bonds **400** might also be useful for cleaning the crease between the textile on a sofa and decorative cording that is commonly found around the edges of components of the sofa such as the cushions, arm rests, and decorative contours, where dirt, food crumbs, dander, and pet hair often accumulate. The stiff longitudinal edge bonds **400** might also be useful for cleaning between the keys of a computer keyboard or piano, within the contours of the facings and buttons of electronic devices such as televisions and stereos, around the edges of picture frames, and other hard to reach narrow creases, cracks, and crevices.

If desired, the longitudinal edge bonds **400** can be continuous or intermittent. Continuous longitudinal edge bonds **400** can be stiffer than intermittent longitudinal edge bonds **400**.

Longitudinal edge bonds **400** can be provided for by thermally bonding the first layer **20**, second layer **30**, and core **40** to one another. As shown in FIG. 6, the longitudinal edge bonds **400** can have a longitudinal edge bond **400** minimum thickness TB and the wipe **10** can have a maximum thickness TL along the longitudinal axis L . The longitudinal edge bond **400** minimum thickness TB and the maximum thickness TL are both measured orthogonal to the longitudinal axis L and out of plane with respect to the first layer **20** and the second layer **30**. The longitudinal edge bond **400** minimum thickness TB can be less than about 80% of the maximum thickness TL . The longitudinal edge bond **400** minimum thickness TB can be less than about 30% of the maximum thickness TL . Without being bound by theory, it is thought that relatively thin longitudinal edge bonds **400** can be beneficial in that they can readily enter narrow creases, cracks, and crevices and be used to clean such features. Further, by having a fatter part of the wipe **10** somewhat away from the thin longitudinal edge bond **400** the wipe can be stuffed to fit into narrow cracks, creases, and crevices, thereby providing for better cleaning, particularly around the exit from such features which may be the most visually apparent portion of the feature.

The maximum thickness TL of the wipe **10** can be between about 3 mm to about 10 mm, or about 3 mm to about 8 mm, or

15

3 mm to about 6 mm Longitudinal edge bonds **400** that comprise the first layer **20**, second layer **30**, and core **40** can have a longitudinal edge bond **400** minimum thickness TB between about 0.1 mm and 2.4 mm The thickness of the longitudinal edge bonds **400** and the transverse edge bonds **410** can be controlled by, for example, altering the pressure and/or heat applied that portion of the wipe **10** to form the respective bond. Higher pressure and greater amounts of heat can be associated with stiffer and or thinner bonds.

The second layer **30** can be a layer that is an interior component of the wipe **10**, as shown in FIG. 7. As shown in FIG. 7, the core **40** can be positioned between the first layer **20** and the second layer **30**. The second layer **30** can be colored, as described previously, for instance by a dye, pigment, ink, or other technique. The second layer **30** can be between the core **40** and the abrasive layer **50**. The abrasive layer **50** can form an exterior surface of the wipe **10** that can be used to dislodge soil from the surface being cleaned. The first layer **20**, second layer **30**, and abrasive layer **50** can be joined to one another along the transverse edges **320**, for instance by thermally bonding the three materials together. The second layer **30**, if colored, can be visible through the first layer **20** at positions where the first layer **20** and second layer **30** are joined to one another and the core **40** is not between the first layer **20** and second layer **30**.

As shown in FIG. 8, the abrasive layer **50** can be the second layer **30**. That is, the wipe **10** can comprise first layer **20** and a second layer **30** and a core **40** positioned between the first layer **20** and second layer **30**, wherein the second layer **30** is an abrasive layer **50**. The abrasive layer **50** can be colored. The abrasive layer **50** can be colored with a material selected from the group consisting of dye, pigment, ink, and combinations thereof.

The first layer **20** can form a first side **330** of the wipe **10**. As shown in FIGS. 9, 10, and 11, the first side **330** of the wipe **10** can comprise one or more channels **250** embossed into the core **40**. Embossed channels **250** can increase the stiffness of the wipe **10** and increase the durability of the wipe **10**.

As shown in FIG. 11, the embossed channels **250** can provide for pillowed regions on the wipe **10** which impart a three-dimensional surface profile from the generally planar surface of the first layer **20**. Channels **250** can be embossed into the wipe **10** in any manner known in the art including embossing, fusion bonding, thermal bonding, and the like for impressing a pattern upon a substrate. Without being bound by theory, it is thought that channels **250** provide for regions of a fibrous substrate that have a higher capillary potential than regions of the fibrous substrate that are devoid of channels **250**. The increased capillarity is provided for by the close proximity of the fibers constituting the fibrous substrate. Channels **250** can provide for pathways of enhanced capillarity throughout the wipe **10**, thereby promoting widespread distribution of the liquid cleaning composition in the wipe **10**.

The channels **250** can be continuous channels **250**. The channels can be discontinuous channels **250**. Discontinuous channels can provide for the pathways of enhanced capillarity in the same manner as continuous channels **250** provided that the spacing between channel segments **26** of the channel **250** are sufficiently small so that fluid can still be conducted from one channel segment to another. For discontinuous channels, the spacing between segments of the channel **250** can be less than the length of the channel segments **26**.

As shown in FIG. 12, a channel **250** can extend away from a longitudinal edge **32**. The longitudinal edge **32** can extend across the longitudinal axis L. By having the channel **250** extend all the way to the longitudinal edge **32**, the liquid cleaning composition might be distributed all the way to the

16

opposing longitudinal edge **32** of the wipe **10**, thereby providing enhanced efficacy of the wipe **10**. The wipe **10** can comprise a plurality of channels **250** each of which extend away from or proximal to the longitudinal edge **32**, with an increased number of channels **250** thought to provide for enhanced distribution of the cleaning composition. One or more channels **250** can extend from one longitudinal edge **32** to an opposing longitudinal edge **32**. That is, one or more channels **250** can extend between the longitudinal edges **32**. Such an arrangement can be practical for distributing cleaning composition along the entire extent of the wipe **10** in longitudinal direction. Further, channels **250** that are generally oriented in the longitudinal direction can provide for enhanced stiffness of the wipe **10** with respect to bending about the transverse axis T.

The wipe **10** can have a longitudinal axis L and a transverse axis T intersecting and orthogonal to the longitudinal axis L and in plane with the wipe **10**. The longitudinal axis L can be longer than the transverse axis T. In other words, the length of the wipe **10** measured along the longitudinal axis L can be longer than the width of the wipe **10** measured along the transverse axis T. The wipe **10** can extend between transverse edges **320** that are disposed across the transverse axis T.

The wipe **10** can have a longitudinal axis L and the wipe **10** can extend between longitudinal edges **32** disposed across the longitudinal axis L. The channels **250** can extend from one or both of the longitudinal edges **32**. The wipe **10** can have transverse axis T orthogonal to the longitudinal axis L and in plane with the wipe **10** and the wipe **10** can extend between the transverse edges **320**. The channels **250** can extend from one or both transverse edges **320**. One or more channels **250** can extend between the transverse edges **320**.

A channel **250** can be formed in one or more layers of the wipe **10**, as shown in FIG. 13. A channel **250** can comprise material from one or more of the first layer **20**, the core **40**, and the second layer **30**. A channel **250** can comprise a material selected from the group consisting of the first layer **20**, the core **40**, the second layer **30**, and combinations thereof. Channels **250** in one or more of the layers comprised of a non-woven material can be practical. The wipe **10** can comprise intersecting channels **250**. Optionally, the channels **250** can be spaced apart from one another.

A channel **250** need not extend all the way to the longitudinal edge **32**. As shown in FIG. 14, the wipe **10** can have one or more longitudinal edge bonds **400**. A channel **250** can extend away from the edge bond **400**. It is contemplated herein that the wipe **10** can comprise a plurality of such channels **250**. The channels **250** can extend away from the longitudinal edge bond **400** to an opposing longitudinal edge bond **400**. As described and shown herein, the longitudinal edge bond **400** can comprise material selected from the group consisting of the first layer **20**, the second layer **30**, the core **40**, and combinations thereof. The longitudinal edge bond **400** can provide for a dense fibrous structure having high capillarity.

Channels **250** can also be beneficial for helping the wipe **10** maintain distribution of the cleaning composition in the wipe **10** when the wipe **10** is packaged such that the package is designed so that one of the longitudinal edges **32** is oriented towards the bottom of the package. In such an arrangement, if the pore sizes of the materials constituting the wipe **10** are so large such that the capillary potential of any part of the wipe **10** is less than the length of the wipe **10** along the longitudinal axis L, the wipe **10** may not be wetted across the entire length along the longitudinal axis L. The channels **250** can help draw up any cleaning composition that is contained in the bottom of

the package higher up into the wipe in the longitudinal direction. The depth of the channels **250** can be greater than about 0.25 mm

One or more channels **250**, continuous or segmented, can extend between the transverse edge bonds **320**, by way of non-limiting example as in FIG. **12**. Plurality of channels **250**, continuous or segmented, can extend between the transverse edge bonds **320**. Such channels **250** can promote distribution of the cleaning composition laterally in the transverse direction and provide for enhanced bending stiffness about the longitudinal axis L. One or more channels **250**, continuous or segmented, can extend between the transverse edges **320**, by way of non-limiting example as shown in FIG. **14**.

The wipe **10** can comprise a first layer **20**, second layer **30** in facing relationship with the first layer **20**, a plurality of channels **250**, and a free liquid cleaning composition releasably absorbed in wipe **10**, for example as shown in FIG. **15**. The cleaning composition can be releasably absorbed in a layer selected from the group consisting of the first layer **20**, the second layer **30**, core **40**, and combinations thereof. A core **40** can be disposed between the first layer **20** and the second layer **30**. The channels **250** can extend from the longitudinal edge **32**. The channels **250** can extend proximal to the longitudinal edge **32**. The channels **250** can extend between the longitudinal edges **32**. The channels **250** can extend from the transverse edge **320**. The channels **250** can extend proximal to the transverse edge **320**. The channels **250** can extend between the transverse edges **320**. The channels **250** can extend to within less than about 10 mm of the longitudinal edge **32** and or transverse edge **320**.

Since the wipe **10** can be designed to use as a hand implement, the wipe **10** can be sized and dimensioned to conform to an adult human hand. For instance, the wipe **10** can have a length, as measured along the longitudinal axis L of between about 8 cm and about 14 cm. The wipe **10** can have a maximum width, as measured orthogonal to the longitudinal axis L and in plane with the first layer **20** of between about 5 cm and about 12 cm.

Fluid Expression

To provide for different sides of the wipe **10** having different functions, it can be practical to make the first side **330** express liquid cleaning composition from the core **40** at a different amount or rate as compared to the second side **340**. For instance, if the first side **330** of the wipe **10** is being used by the consumer for wiping a sofa, the user's objective may be removal of light dust and pet hair. The cleaning capability of the wipe **10** for cleaning light dust and pet hair may not require as much cleaning composition to be effective as compared to a cleaning effort on more heavily soiled surfaces employing the second side **340** of the wipe **10**. As such, it may be beneficial to have first side **330** express liquid more slowly or in a lower quantity than the second side **340**. The quantity of liquid cleaning composition expressed from a particular side of the wipe **10** can be quantified by the cumulative wipe fluid loss value. To provide for a marked difference in cleaning composition expression, the first side **330** and second side **340** can each have an individual cumulative wipe fluid loss value and the cumulative wipe fluid loss value of the first side **330** and the cumulative wipe fluid loss value of the second side **340** can differ by more than about 10%. Such a difference can provide for a user noticeable difference in cleaning composition expression from the first side **330** as compared to the second side **340**. If desired, the cumulative wipe fluid loss value of the second side **340** can be more than about 10% greater than the cumulative wipe fluid loss value of the first side **330**. Such an arrangement can be practical if the first side

330 is designed for light cleaning and the second side **340** is designed for more heavy cleaning.

The cumulative wipe fluid loss value is measured as follows. A stack of layers of

Ahlstrom filter paper grade 989 supplied by Empirical Manufacturing Company (or equivalent) is provided. The number of layers needs to be sufficient so that at least the bottom 3 layers are substantially dry after completion of the test so that the stack of filter paper is not wetting through. A layer is considered substantially dry if the percent change in the mass of the layer in percent post-test as compared to the pre-test dry mass is less than 1%. The dimensions of each layer of filter paper need to extend laterally beyond the wipe being tested by 13 mm. The filter paper is conditioned in advance of the test for at least 12 hrs at a temperature of 21.1° C. +/-1° C. and a relative humidity of 65% and the measurement of the cumulative wipe fluid loss value is measured under the same conditions. The wipe is temperature conditioned for 12 hours at 21.1° C. +/-1° C. The wipe is tested in its as wetted state.

The wipe being tested, which has cleaning composition absorbed therein, is weighed using a Sartorius E2000D laboratory balance. Then the wipe is placed flat and centered onto the stack of filter paper. A rigid non-porous weight having an area greater than the area of the wipe is applied to the wipe so that the pressure applied to the wipe is 5.59 kPa +/-0.34 kPa. The area used to compute the pressure is the plane area of the wipe minus the area of any bond(s) about the periphery of the wipe.

The pressure is applied to the wipe within 1 second in a manner such that the pressure applied does not exceed 5.59 kPa +/-0.34 kPa at any time during the pressure application and then left on the wipe so that the total pressure is supported by the wipe for 30 seconds. After 30 seconds, the applied pressure is removed and the wipe is immediately weighed using the laboratory balance. The difference in weight of the wipe before the pressure is applied and after the pressure is applied and removed is the cumulative wipe fluid loss value for the side of the wipe facing the filter paper layers. A fresh wipe and fresh filter paper is used for each measurement of cumulative wipe fluid loss value that is made.

Specimens of wipe **10** were constructed as follows. All components of the wipe, except the core, had dimensions of 8.89 cm by 11.43 cm. The core **40** had dimensions of 7.94 cm by 11.43 cm. The core **40** formed part of the longitudinal edge bonds and was not part of the lateral edge bonds. The wipe consisted of the following layers, progressing from the first side to the second side: a 25 gram per square meter polyethylene vacuum formed film sold as product ID PT02 by Clopay and a 28 gram per square meter 50/50 polyethylene sheath/polypropylene core bi-component fiber laminated together using the process in U.S. Pat. No. 5,628,097, issued to Benson and Curro, on May 13, 1997; a layered core of a laminate of an 80 gram per square meter nonwoven of bicomponent fibers, the bicomponent fibers comprising a polyethylene sheath and a polyethylene terephthalate core having a loft of about 2.5 mm overlying two layers of a multi bonded air-laid core comprising about 15% by weight bicomponent fibers having a polyethylene sheath and polyethylene terephthalate core, about 2.5% by weight latex, about 82% pulp, and a basis weight of about 135 grams per square meter; two layers of 15 gram per square meter polypropylene nonwoven, and the bottom layer was laminate of a 60 gram per square meter

SOFSPAN 120 nonwoven, available from Fiberweb and a polypropylene fine square structure net PF40 sold by Smith and Nephew Extruded Films, East Yorkshire, England, the layers being combined following the process in U.S. Pat. No.

7,917,985 issued to Dorsey et al. on Apr. 5, 2011, with the net material being on the second side of the wipe/oriented towards the exterior of the wipe. Each wipe was loaded with 19 g +/-0.3 g of cleaning composition according to Table 1.

The cumulative wipe fluid loss value of the side of the wipe having the netting material was 7.86 g with a standard deviation of 0.15 g, based on the average of six specimens tested. The cumulative wipe fluid loss value of the side of the wipe having the vacuum formed film was 9.92 g with a standard deviation of 0.30 g, based on the average of six specimens tested. The cumulative wipe fluid loss value of the side of the wipe having the netting material was 26% greater than the cumulative wipe fluid loss value of the side of the wipe having the vacuum formed film.

The dimensions and values disclosed herein are not to be understood as being strictly limited to the exact numerical values recited. Instead, unless otherwise specified, each such dimension is intended to mean both the recited value and a functionally equivalent range surrounding that value. For example, a dimension disclosed as "40 mm" is intended to mean "about 40 mm."

Every document cited herein, including any cross referenced or related patent or application, is hereby incorporated herein by reference in its entirety unless expressly excluded or otherwise limited. The citation of any document is not an admission that it is prior art with respect to any invention disclosed or claimed herein or that it alone, or in any combination with any other reference or references, teaches, suggests or discloses any such invention. Further, to the extent that any meaning or definition of a term in this document conflicts with any meaning or definition of the same term in a document incorporated by reference, the meaning or definition assigned to that term in this document shall govern.

While particular embodiments of the present invention have been illustrated and described, it would be obvious to those skilled in the art that various other changes and modifications can be made without departing from the spirit and scope of the invention. It is therefore intended to cover in the appended claims all such changes and modifications that are within the scope of this invention.

What is claimed is:

1. A premoistened cleaning wipe comprising:

a liquid permeable first layer joined in facing relationship to a liquid permeable second layer, wherein said liquid permeable first layer comprises a nonwoven and said second layer comprises a substrate and a layer of netting material bonded to said substrate;

a core disposed between said first layer and said second layer; and

a free liquid cleaning composition comprising between about 0.001% to about 10% by weight of said liquid cleaning composition of surfactant, said cleaning composition releasably absorbed in said core;

wherein said first layer forms a first side of said wipe and said wipe has a second side opposing said first side, wherein said first side and said second side each have an individual cumulative wipe fluid loss value and said cumulative wipe fluid loss value of said first side and said cumulative wipe fluid loss value of said second side differ by more than about 10%.

2. The premoistened cleaning wipe according to claim 1, wherein said netting material comprises broken strands.

3. The premoistened cleaning wipe according to claim 2, wherein said netting material comprises a first set of strands and a second set of strands wherein said first set of strands crosses and interconnects said second set of strands at a substantially fixed angle wherein the strands in each said

respective set of strands extend along a respective direction and are in substantially coplanar, spaced apart relationship.

4. The premoistened cleaning wipe according to claim 3, wherein said broken strands form raised whiskers that extend away from the substrate.

5. The premoistened cleaning wipe according to claim 4, wherein said substrate is a woven or nonwoven material.

6. The premoistened cleaning wipe according to claim 1, wherein said nonwoven is an apertured nonwoven.

7. The premoistened cleaning wipe according to claim 1, wherein said wipe is sized and dimensioned to conform to an adult human hand.

8. The premoistened cleaning wipe according to claim 1, wherein said core is a material selected from the group consisting of polyolefin fibers, cellulose fibers, rayon, open celled foam, and combinations thereof.

9. The premoistened cleaning wipe according to claim 1, wherein said first layer is a nonwoven comprising polyolefin fibers.

10. The premoistened cleaning wipe according to claim 1, wherein said wipe extends along a longitudinal axis, wherein said first layer, said second layer, and said core are coextensive with one another along said longitudinal axis.

11. The premoistened cleaning wipe according to claim 1, wherein said wipe extends along a longitudinal axis wherein said first layer and said second layer extend longitudinally beyond said core and extend further away from said longitudinal axis than said core.

12. The premoistened cleaning wipe according to claim 1, wherein said first layer forms a first side of said wipe, wherein said first side of said wipe comprises one or more embossed channels embossed into said core.

13. The premoistened cleaning wipe according to claim 1, wherein said cumulative wipe fluid loss value of said second side is more than 10% greater than said cumulative wipe fluid loss value of said first side.

14. The premoistened cleaning wipe according to claim 1, wherein said wipe extends along a longitudinal axis, wherein said first layer and said second layer extend further away from said longitudinal axis than said core.

15. The premoistened cleaning wipe according to claim 1, wherein said liquid cleaning composition further comprises an antifoam compound.

16. The premoistened cleaning wipe according to claim 1, wherein said nonwoven is a spun bonded nonwoven.

17. The premoistened cleaning wipe according to claim 1, wherein said nonwoven is an apertured spun bonded nonwoven.

18. The premoistened cleaning wipe according to claim 1, wherein said nonwoven has a basis weight of between about 15 grams per square meter and about 80 grams per square meter.

19. A premoistened cleaning wipe comprising:

a liquid permeable first layer joined in facing relationship to a liquid permeable second layer, wherein said liquid permeable first layer comprises an apertured nonwoven and said second layer comprises a substrate and a layer of netting material bonded to said substrate, wherein said netting material comprises broken strands, wherein said netting material comprises two sets of strands wherein each set of strands crosses and interconnects another set of strands at a substantially fixed angle wherein the strands in each set of strands extend along a respective direction and are in substantially coplanar, spaced apart relationship, wherein said broken strands form raised whiskers that extend away from the substrate;

a core disposed between said first layer and said second layer; and
a free liquid cleaning composition comprising between about 0.001% to about 10% by weight of said liquid cleaning composition of surfactant, said cleaning com- 5
position releasably absorbed in said core;
wherein said wipe is sized and dimensioned to conform to an adult human hand; and
wherein said first layer forms a first side of said wipe and said wipe has a second side opposing said first side, 10
wherein said first side and said second side each have an individual cumulative wipe fluid loss value and said cumulative wipe fluid loss value of said first side and said cumulative wipe fluid loss value of said second side differ by more than about 10%. 15

* * * * *