



US008984679B2

(12) **United States Patent**  
**Bayley et al.**

(10) **Patent No.:** **US 8,984,679 B2**  
(45) **Date of Patent:** **Mar. 24, 2015**

(54) **LAVATORY SYSTEM**

USPC ..... 251/129.04; 4/623, 302, 304, 305, 313;  
307/39, 126, 132 R, 132 E

(75) Inventors: **Graeme S. Bayley**, Brookfield, WI (US);  
**John Loberger**, Germantown, WI (US);  
**Brendan Doorhy**, Westmont, IL (US);  
**Joseph Mazza**, Elgin, IL (US); **Brian**  
**Gaza**, Naperville, IL (US); **Donald**  
**O'Brien**, Buffalo Grove, IL (US)

See application file for complete search history.

(56) **References Cited**

U.S. PATENT DOCUMENTS

4,239,555 A 12/1980 Scharlack et al.  
4,256,133 A 3/1981 Coward et al.

(Continued)

FOREIGN PATENT DOCUMENTS

CA 2 068 693 12/1992  
DE 42 18 658 12/1992

(Continued)

(73) Assignee: **Bradley Fixtures Corporation**,  
Menomonee Falls, WI (US)

(\*) Notice: Subject to any disclaimer, the term of this  
patent is extended or adjusted under 35  
U.S.C. 154(b) by 5 days.

(21) Appl. No.: **13/367,945**

(22) Filed: **Feb. 7, 2012**

OTHER PUBLICATIONS

(65) **Prior Publication Data**  
US 2012/0131744 A1 May 31, 2012

Canadian Office Action for Canadian Application No. 2,554,133  
dated Aug. 6, 2012, 3 pages.

(Continued)

**Related U.S. Application Data**

(60) Continuation of application No. 11/858,800, filed on  
Sep. 20, 2007, now Pat. No. 8,113,483, which is a  
division of application No. 11/041,882, filed on Jan.  
21, 2005, now abandoned.

*Primary Examiner* — Marina Tietjen

(74) *Attorney, Agent, or Firm* — Foley & Lardner LLP

(60) Provisional application No. 60/538,583, filed on Jan.  
23, 2004, provisional application No. 60/602,585,  
filed on Aug. 18, 2004.

(57) **ABSTRACT**

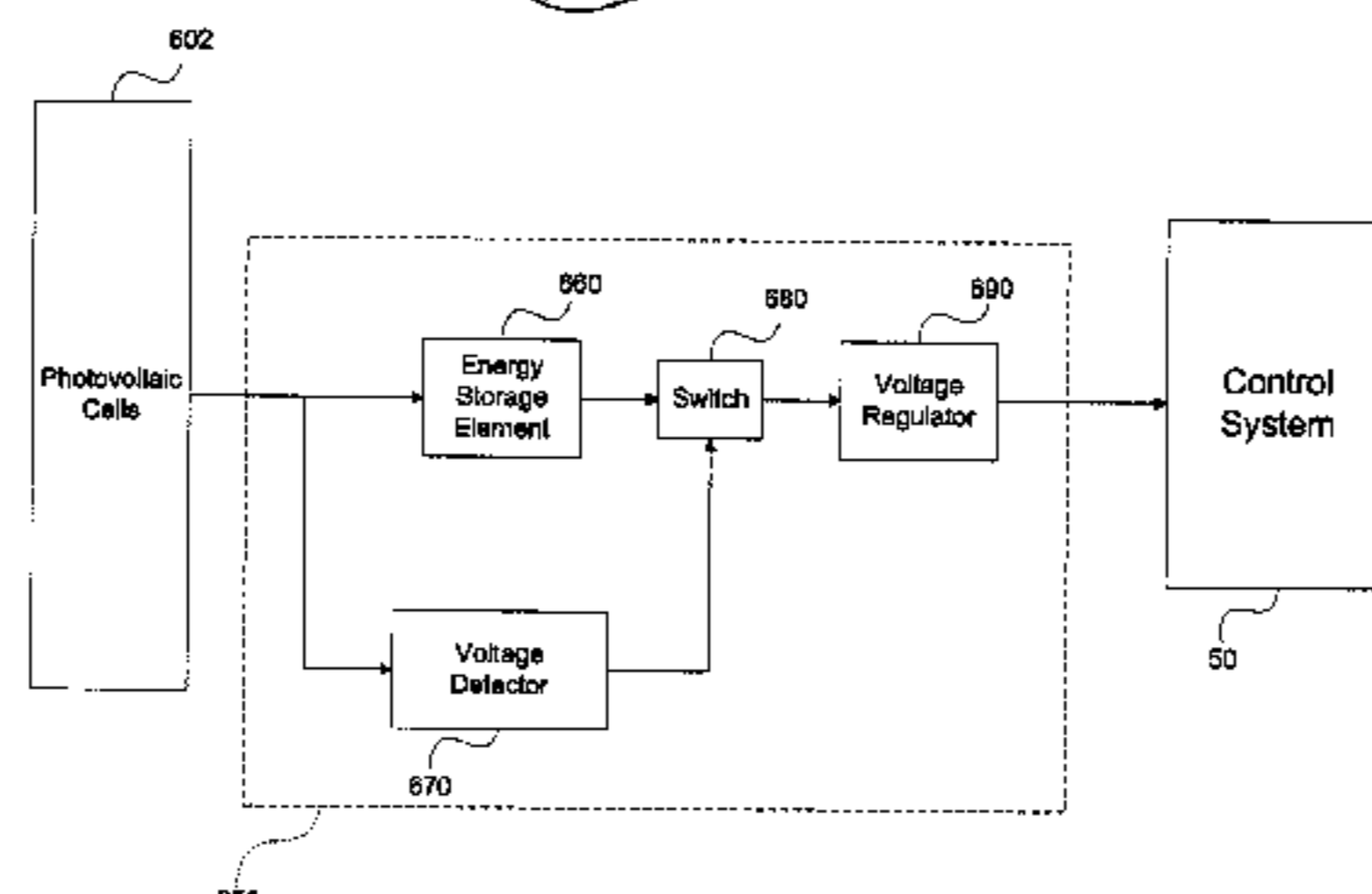
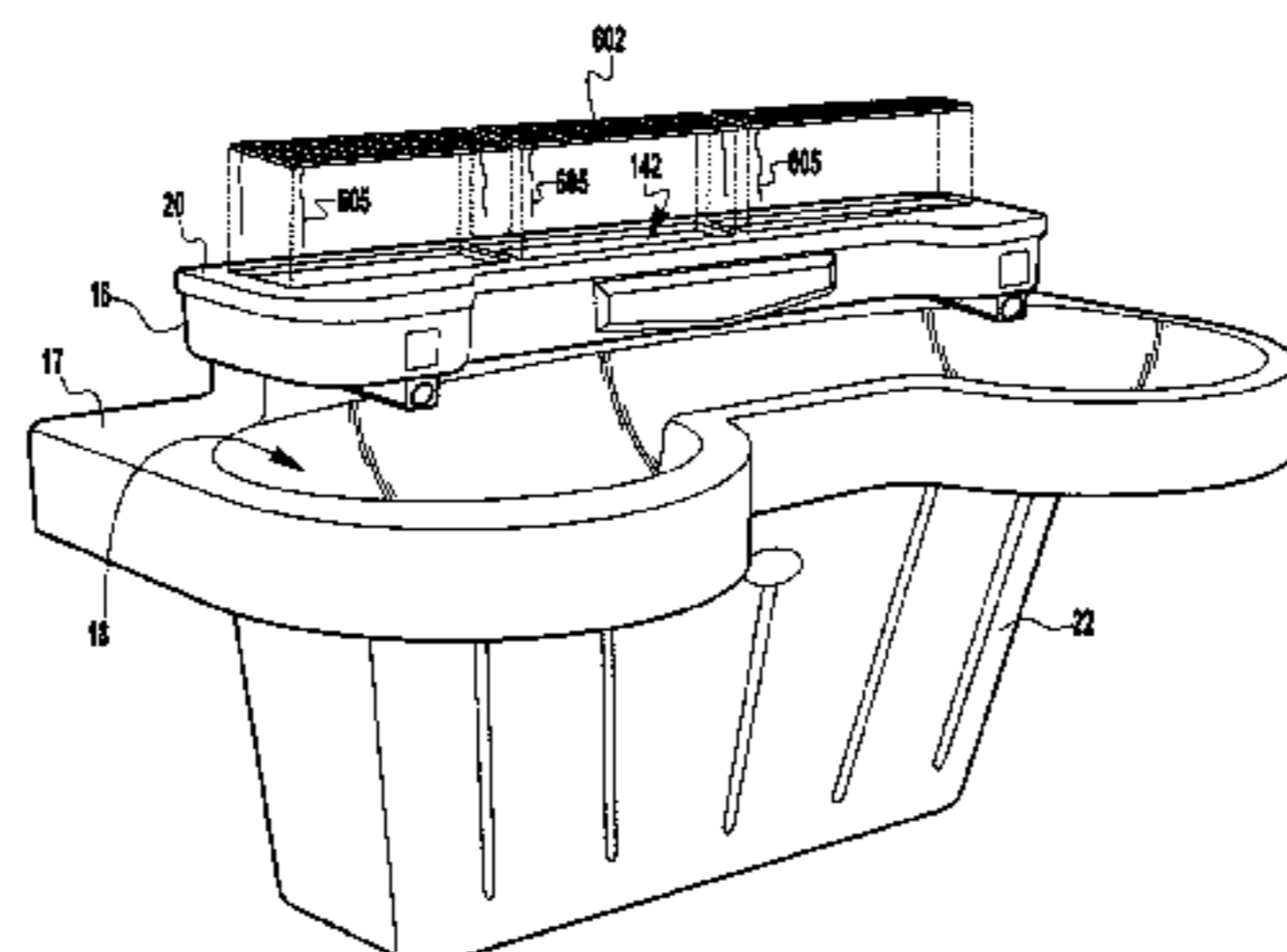
A lavatory is provided. The lavatory includes at least one  
wash station, at least one electrically operated fixture associ-  
ated with the wash station, a control system configured to  
control a flow of a fluid through the at least one electrically  
operated fixture, a power source selectively coupled to the  
control system, and a power management system coupled to  
the power source to control the power provided to the control  
system. The power management system includes a detector  
configured to monitor the output voltage of the power source,  
and a switch configured to electrically disconnect the power  
source from the control system when the output voltage of the  
power source drops below a predetermined level.

(51) **Int. Cl.**  
**E03C 1/05** (2006.01)  
**E03D 5/10** (2006.01)  
**G01S 17/02** (2006.01)

(52) **U.S. Cl.**  
CPC ..... **E03C 1/057** (2013.01); **E03D 5/105**  
(2013.01); **G01S 17/026** (2013.01)  
USPC ..... **4/623**; 251/129.04; 307/126; 307/130

(58) **Field of Classification Search**  
CPC ..... E03C 1/05; E03C 1/057; E03D 5/10;  
E03D 5/105; G01S 17/026

**17 Claims, 14 Drawing Sheets**



(56)

References Cited

U.S. PATENT DOCUMENTS

4,541,563	A	9/1985	Uetsuhara	
4,644,256	A	2/1987	Farias et al.	
4,722,372	A	2/1988	Hoffman et al.	
4,742,583	A	5/1988	Yoshida et al.	
4,744,515	A	5/1988	Watanabe	
4,761,840	A	8/1988	Harding	
4,839,039	A	6/1989	Parsons et al.	
4,852,802	A	8/1989	Iggulden et al.	
4,916,382	A	4/1990	Kent	
4,959,603	A	9/1990	Yamamoto et al.	
4,980,574	A	12/1990	Cirrito	
5,063,955	A *	11/1991	Sakakibara .....	137/1
5,224,685	A	7/1993	Chiang et al.	
5,235,232	A	8/1993	Conley et al.	
5,251,872	A	10/1993	Kodaira	
5,367,442	A	11/1994	Frost et al.	
5,398,182	A	3/1995	Crosby	
5,418,402	A	5/1995	Fujiwara	
5,436,513	A	7/1995	Kaye et al.	
5,497,135	A	3/1996	Wisskirchen et al.	
5,515,818	A	5/1996	Born	
5,565,714	A	10/1996	Cunningham	
5,588,636	A	12/1996	Eichholz et al.	
5,611,093	A	3/1997	Barnum et al.	
5,651,384	A	7/1997	Rudrich	
5,960,813	A	10/1999	Sturman et al.	
6,056,808	A	5/2000	Krause	
6,257,264	B1	7/2001	Sturman et al.	
6,268,559	B1	7/2001	Yamawaki	
6,286,153	B1	9/2001	Keller	
6,313,609	B1 *	11/2001	Brink .....	320/132
6,393,634	B1	5/2002	Kodaira et al.	
6,405,995	B1	6/2002	Spain	
6,420,646	B2	7/2002	Benz et al.	

6,523,193	B2	2/2003	Saraya
6,568,655	B2	5/2003	Paese et al.
6,964,404	B2	11/2005	Patterson et al.
7,075,768	B2	7/2006	Kaneko
2001/0022352	A1	9/2001	Rudrich
2002/0157176	A1	10/2002	Wawrla et al.
2002/0171056	A1	11/2002	Paese et al.
2004/0035976	A1	2/2004	Byrd et al.
2004/0066271	A1	4/2004	Leck
2004/0083547	A1	5/2004	Mercier
2005/0205818	A1	9/2005	Bayley et al.

FOREIGN PATENT DOCUMENTS

DE	196 08 157	7/1997
DE	102 10 474	9/2002
EP	1 057 942	12/2000
EP	1170805	1/2002
EP	1 241 301	9/2002
FR	2802792	6/2001
GB	2 428 004	1/2007
JP	07102601	* 4/1995
JP	9-242155	9/1997
JP	11222902	* 8/1999
JP	2000-282528	10/2000
WO	WO 01/16436	3/2001
WO	WO 2005/073476	8/2005

OTHER PUBLICATIONS

International Search Report and Written Opinion for Application No. PCT/US2005/002194, date of mailing May 12, 2005, 9 pages.  
 International Search Report and Written Opinion for International Application No. PCT/US2009/068735, date mailed Apr. 19, 2010, 11 pages.

\* cited by examiner

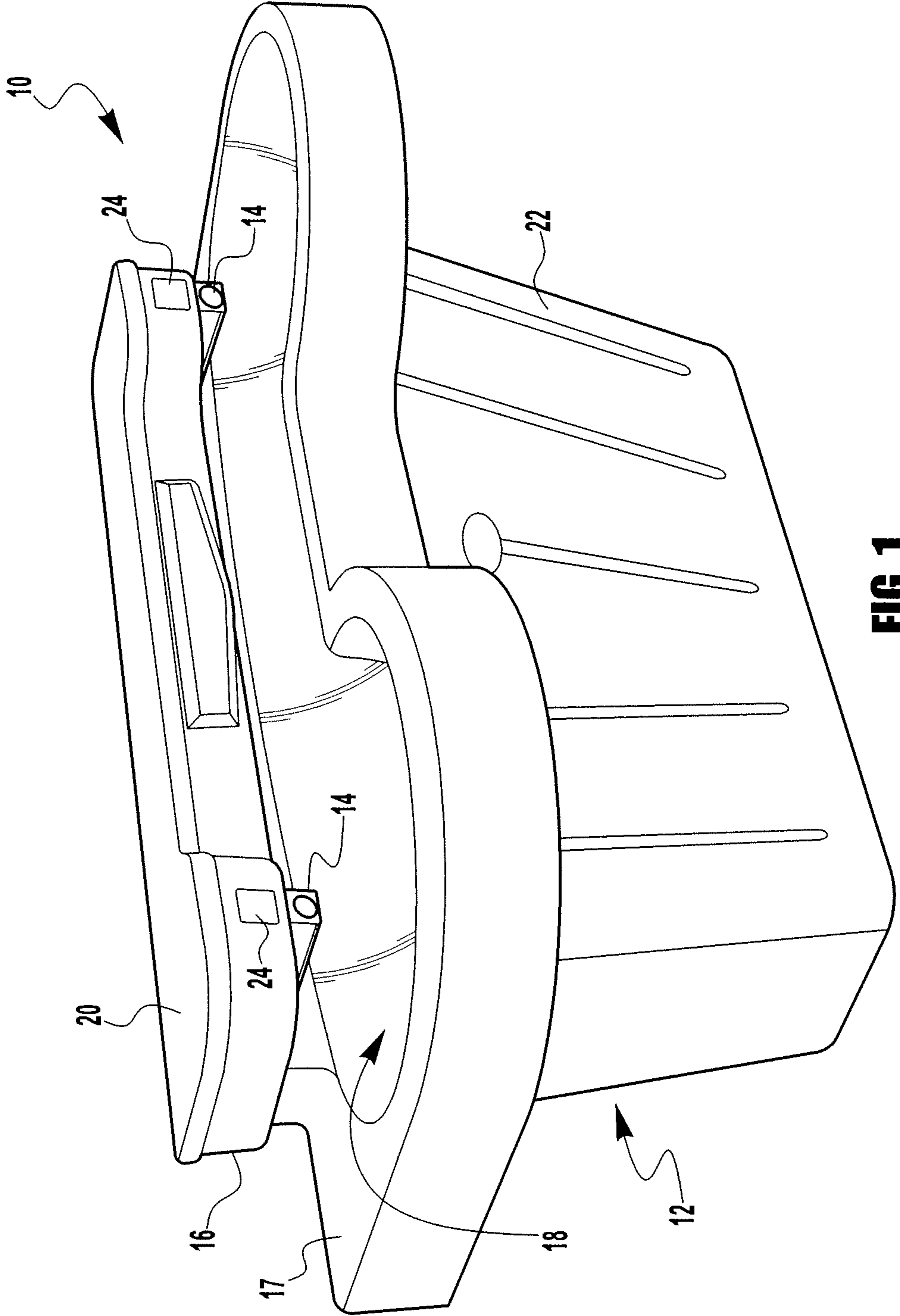
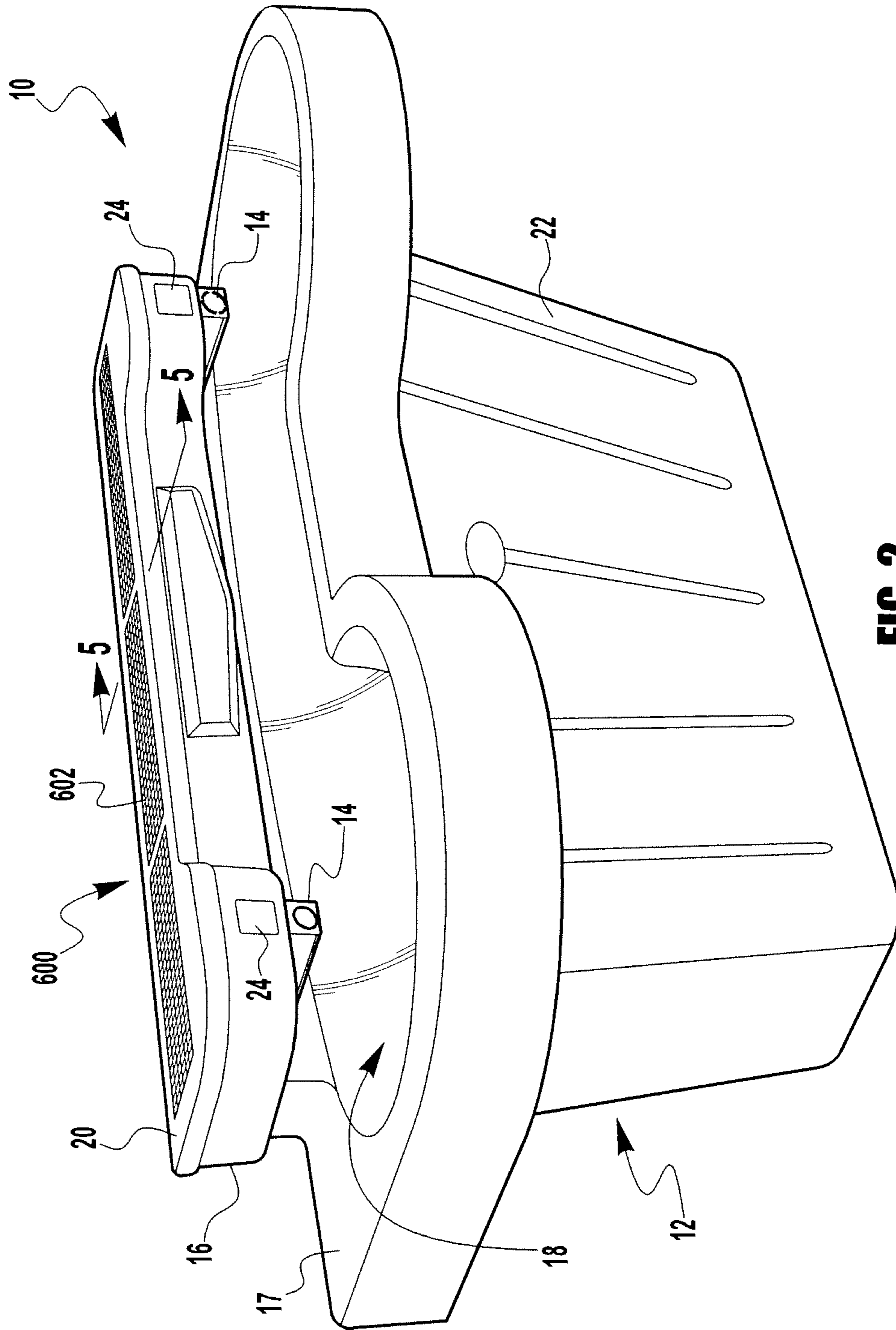
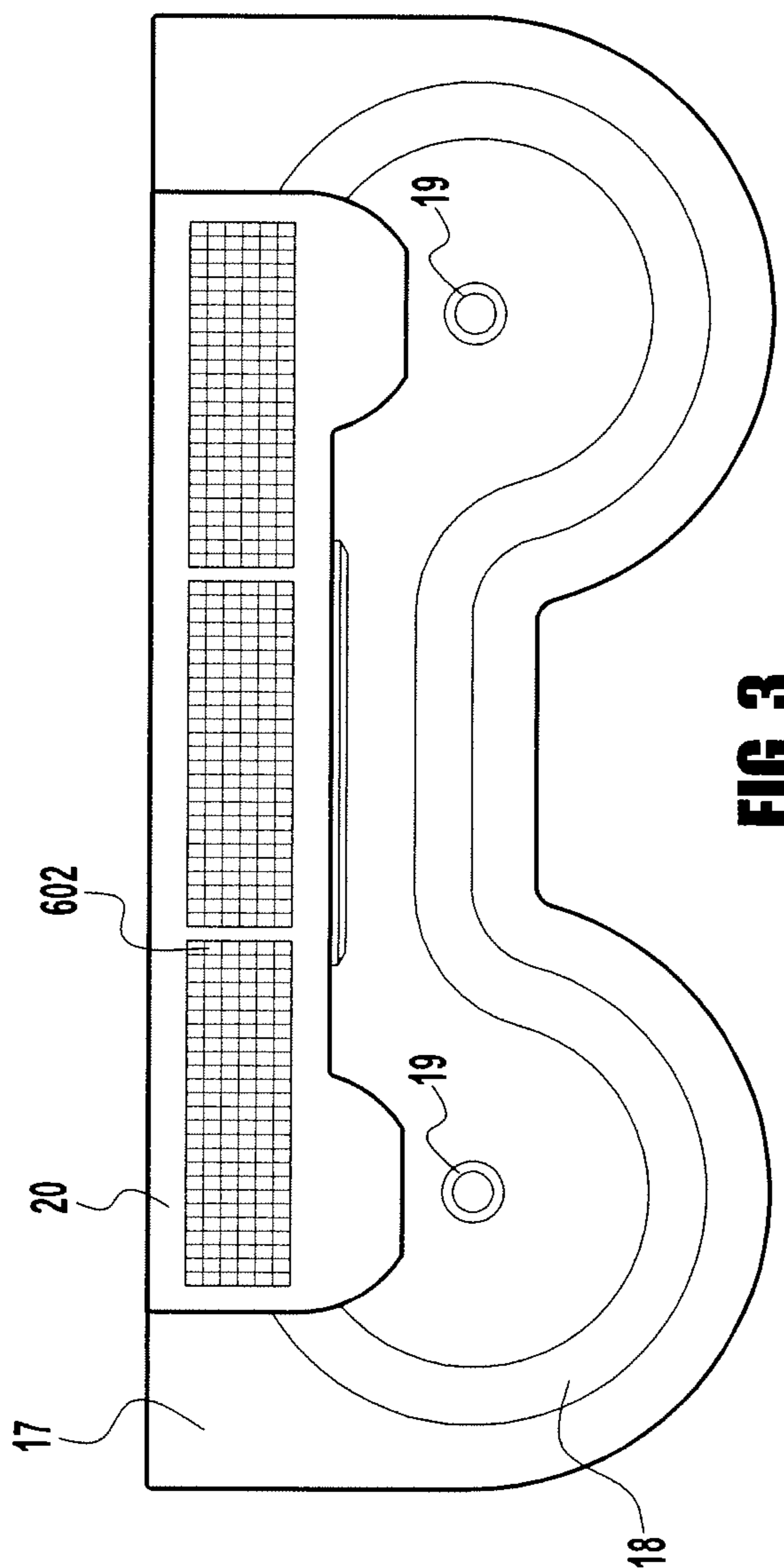


FIG. 1



**FIG. 2**



**FIG. 3**

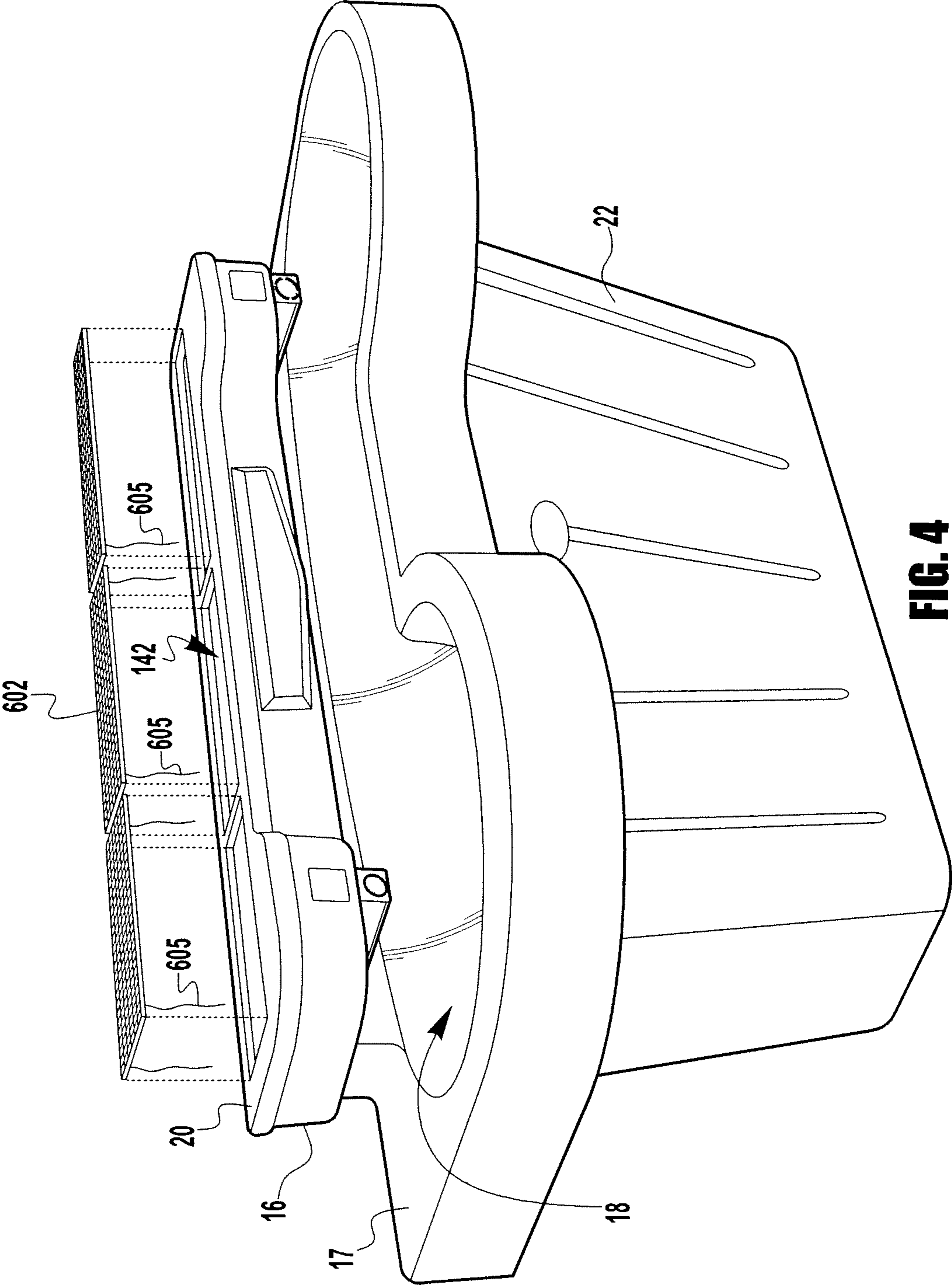
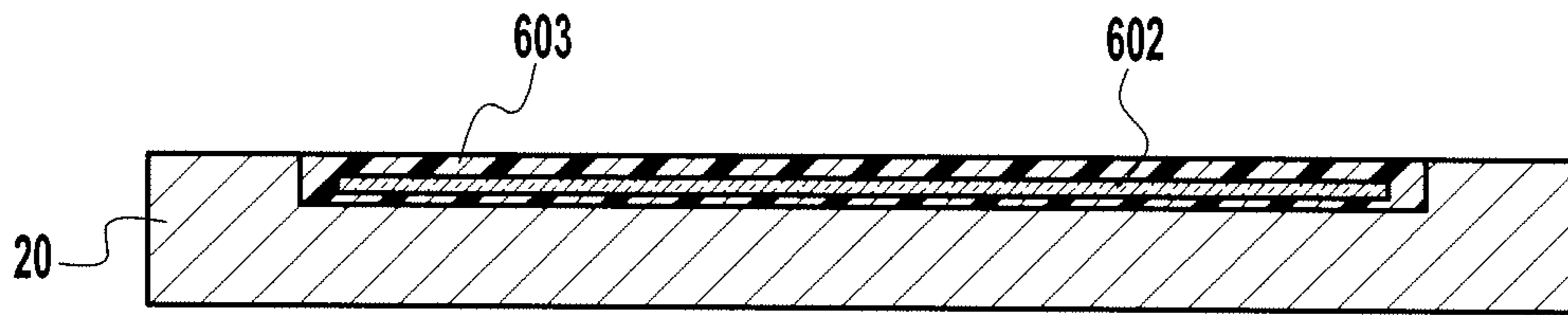
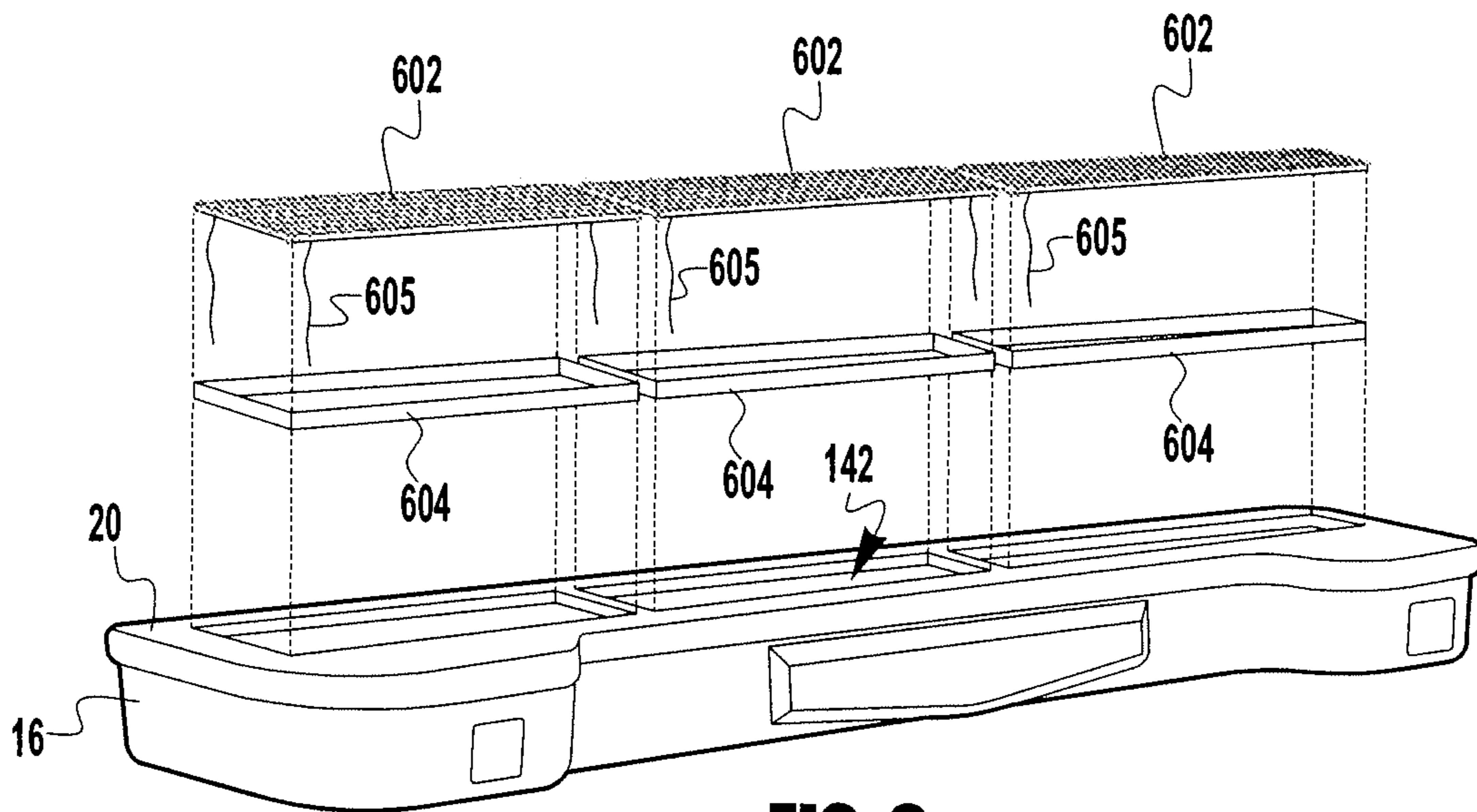


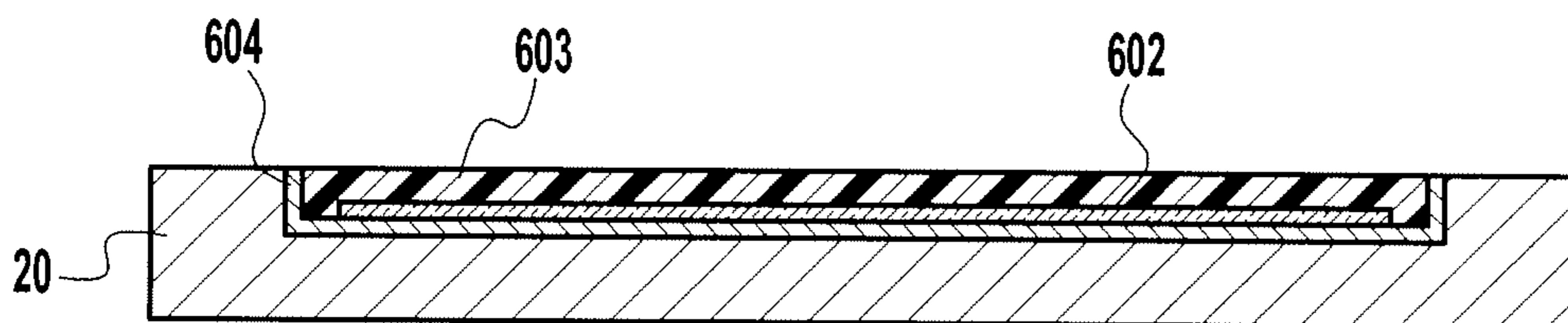
FIG. 4



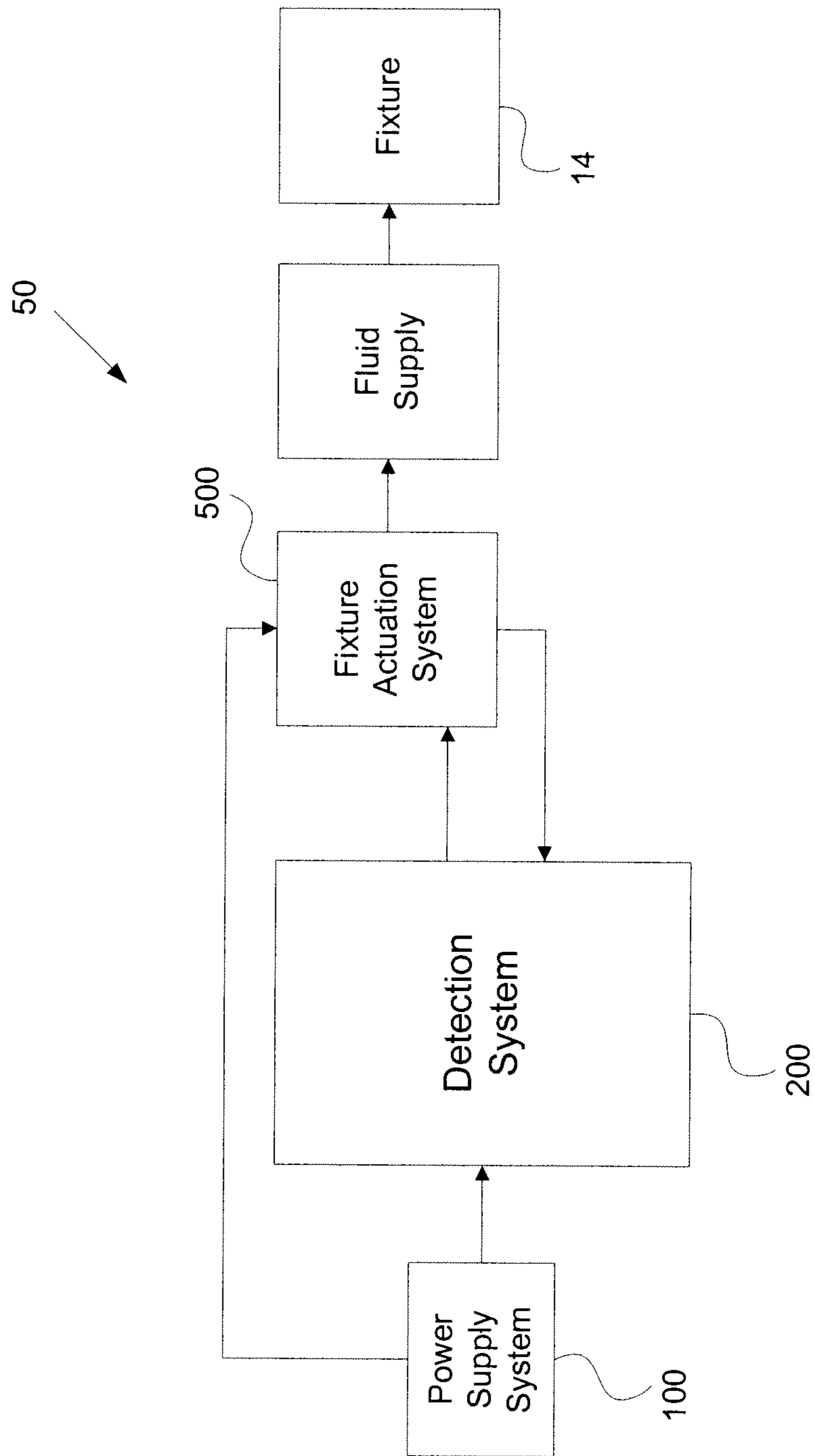
**FIG. 5**



**FIG. 6**

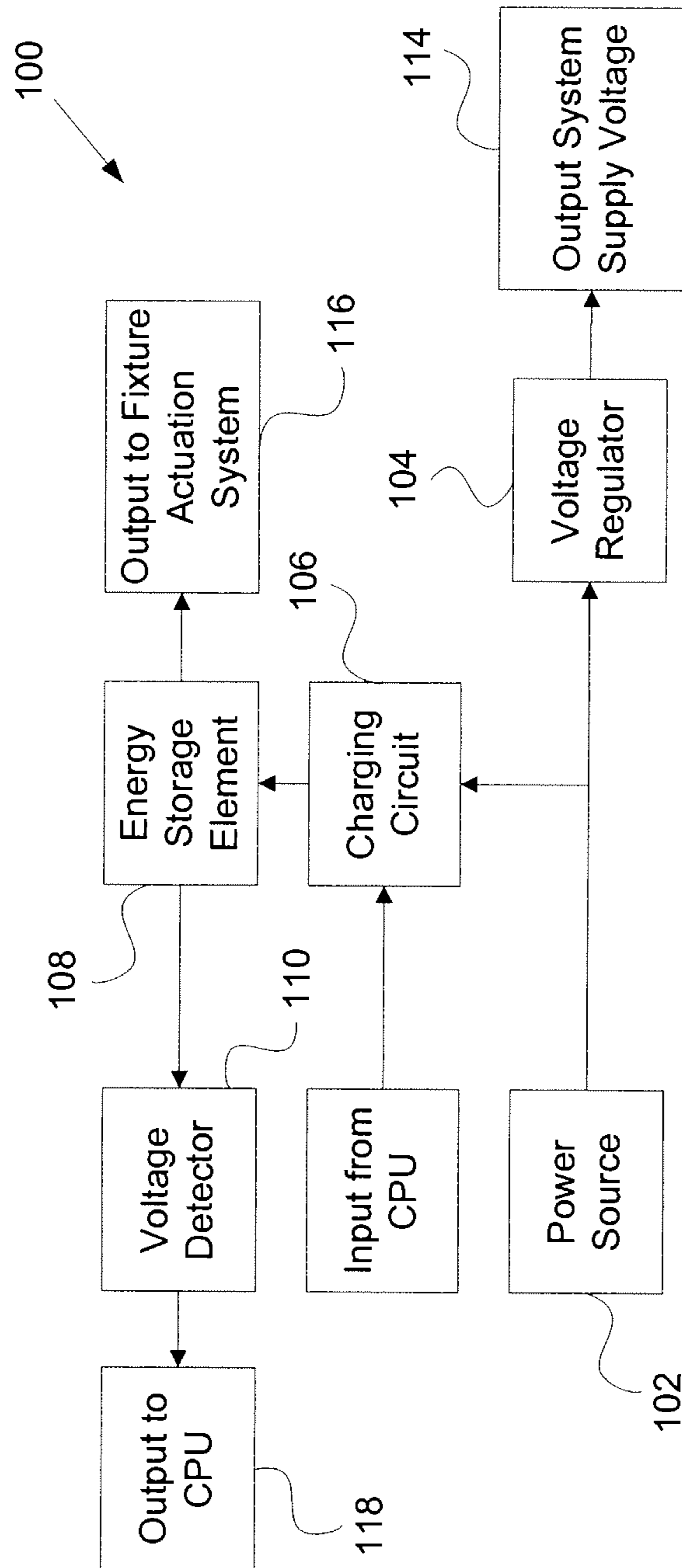


**FIG. 7**

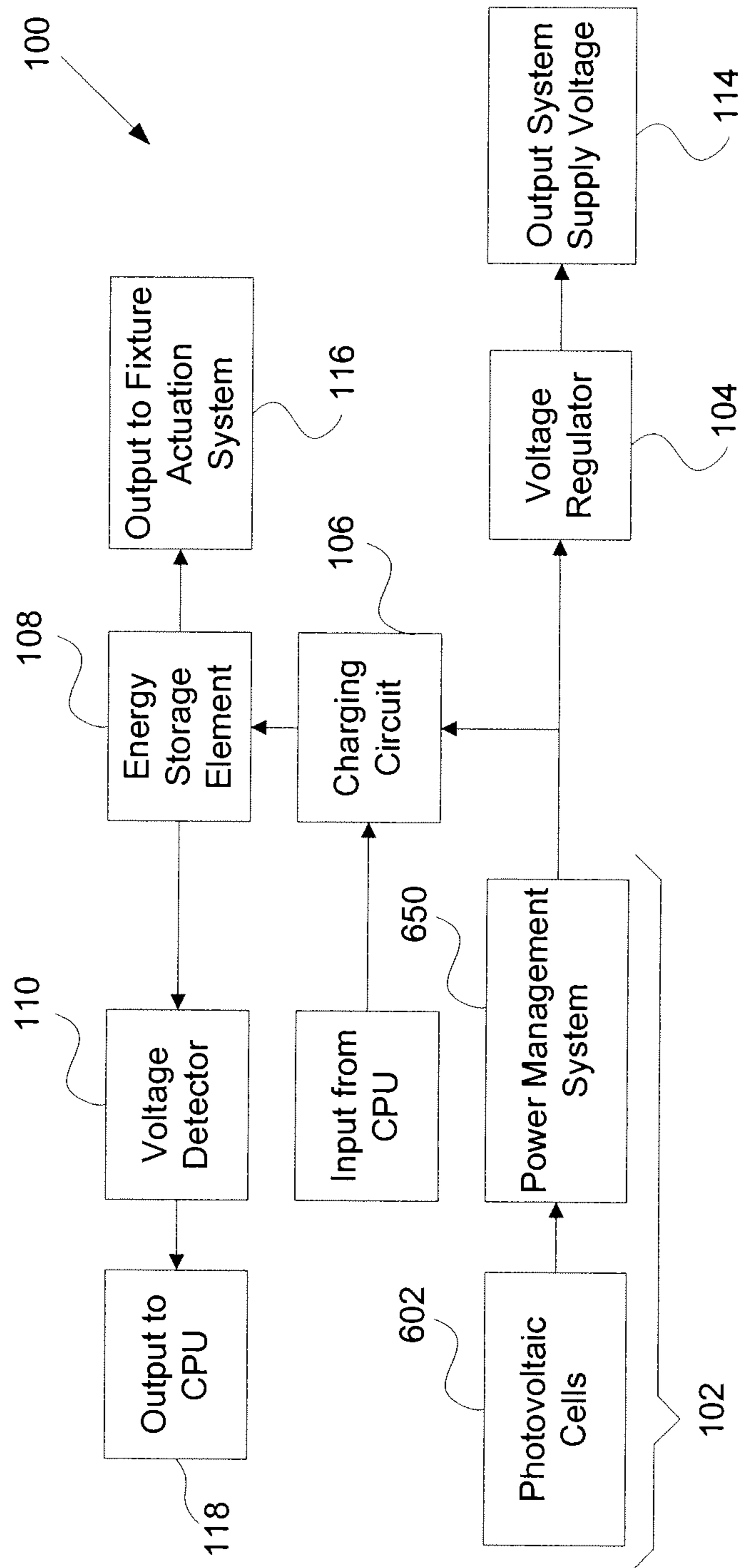


**FIG. 8**





**FIG. 9**



**FIG. 10**

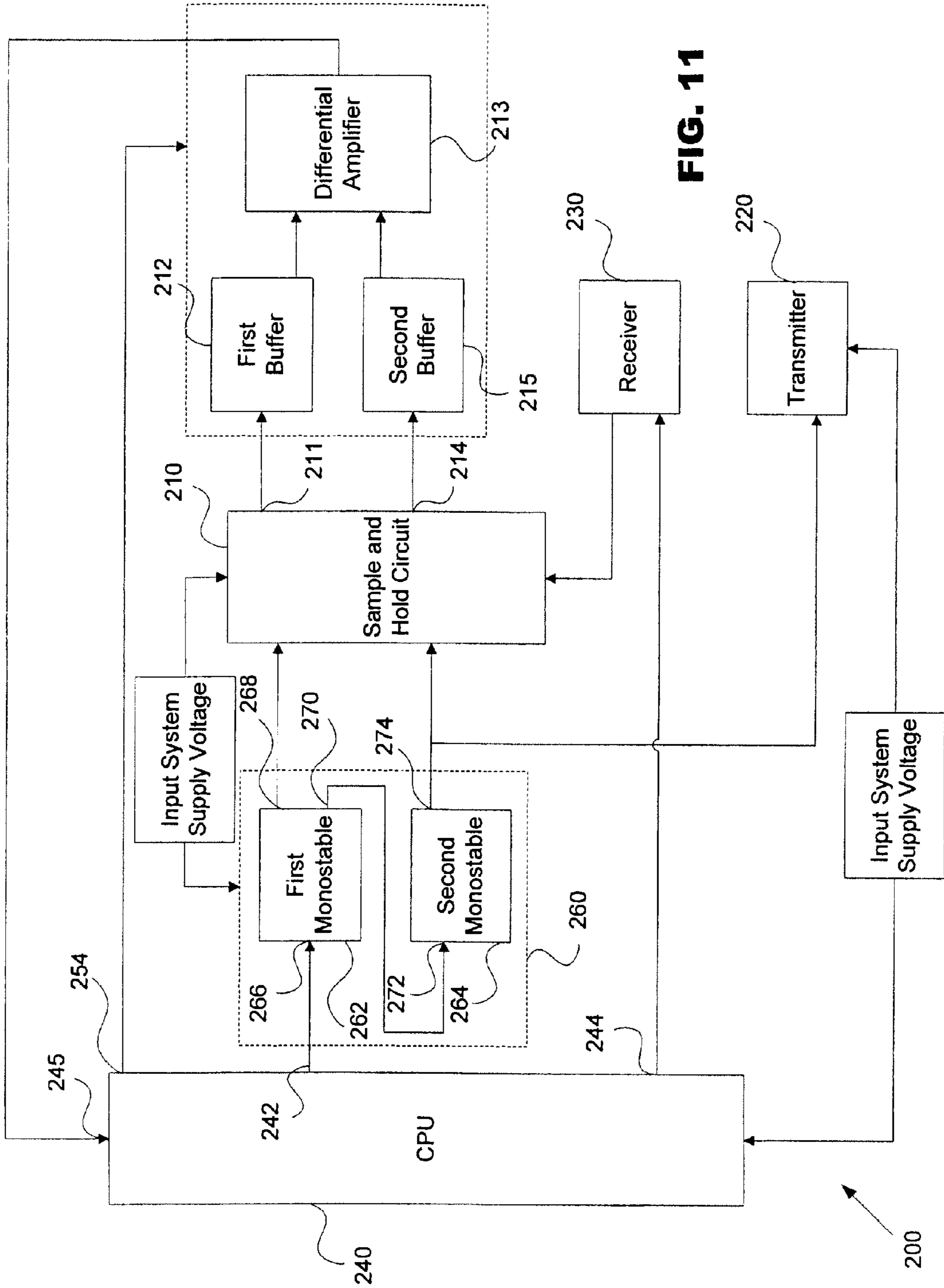
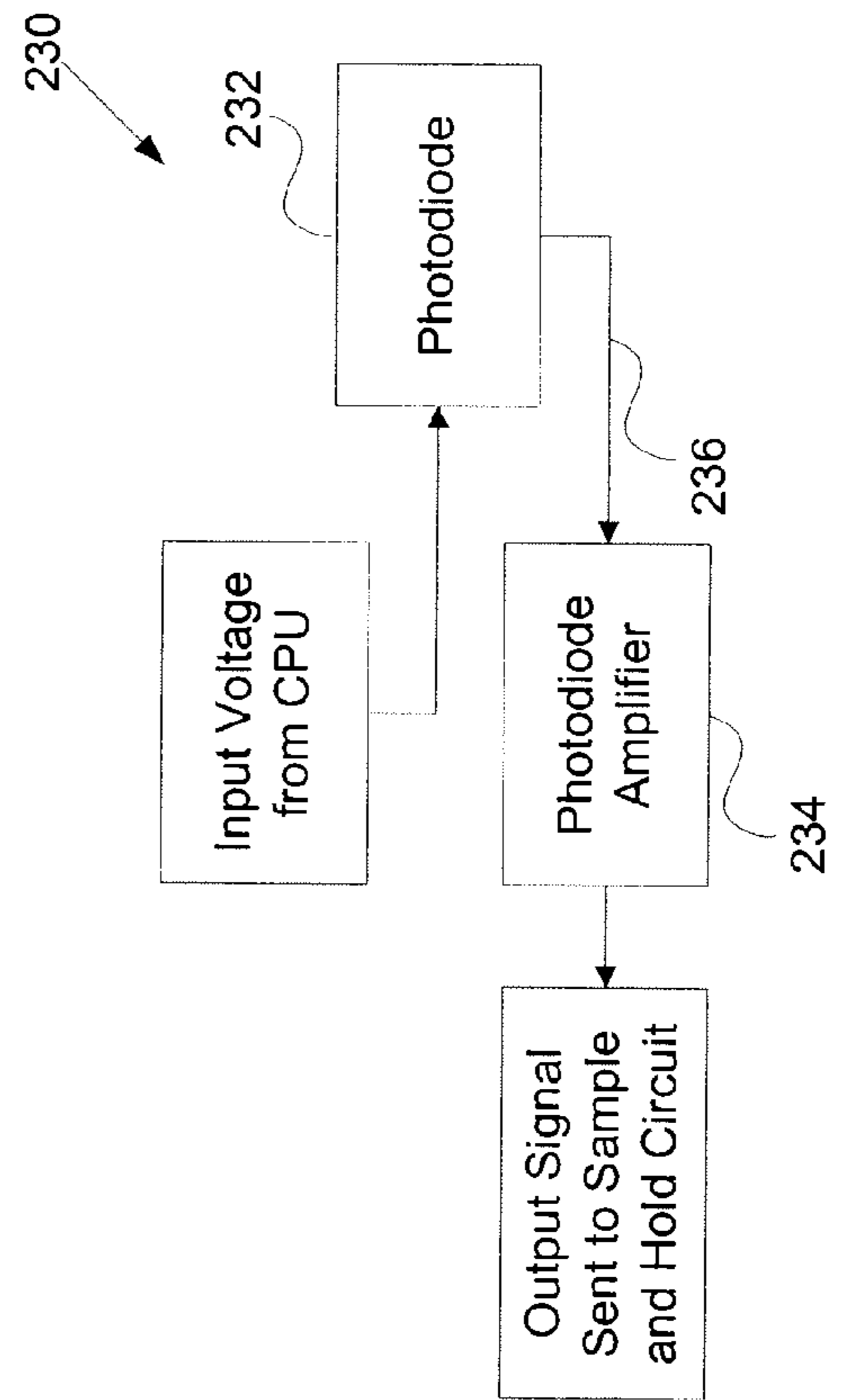
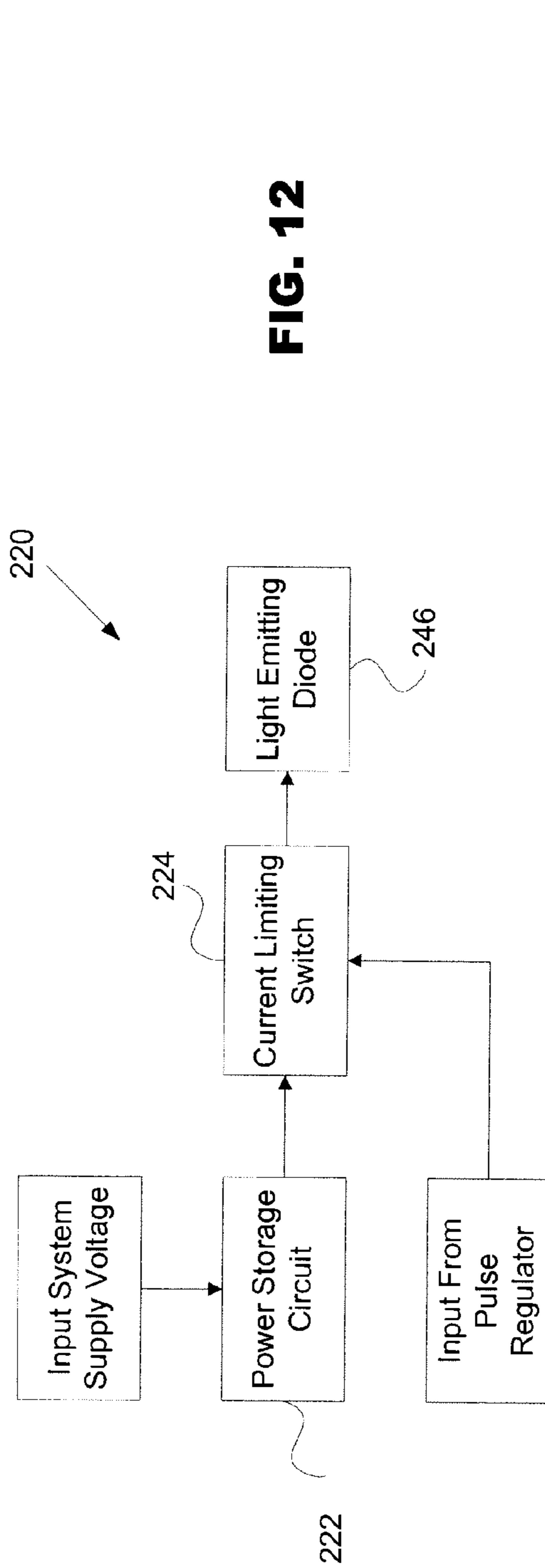
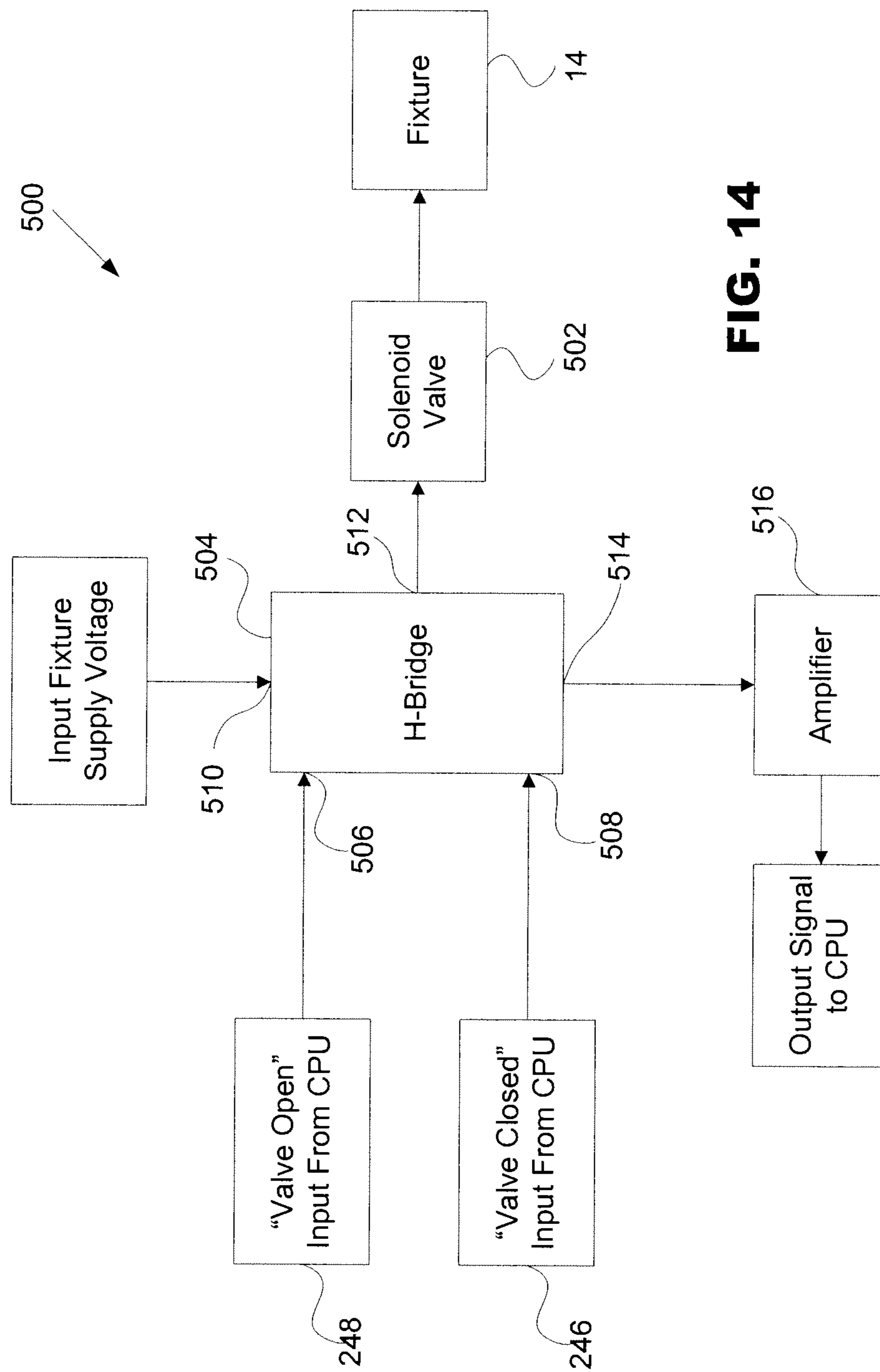


FIG. 11





**FIG. 14**

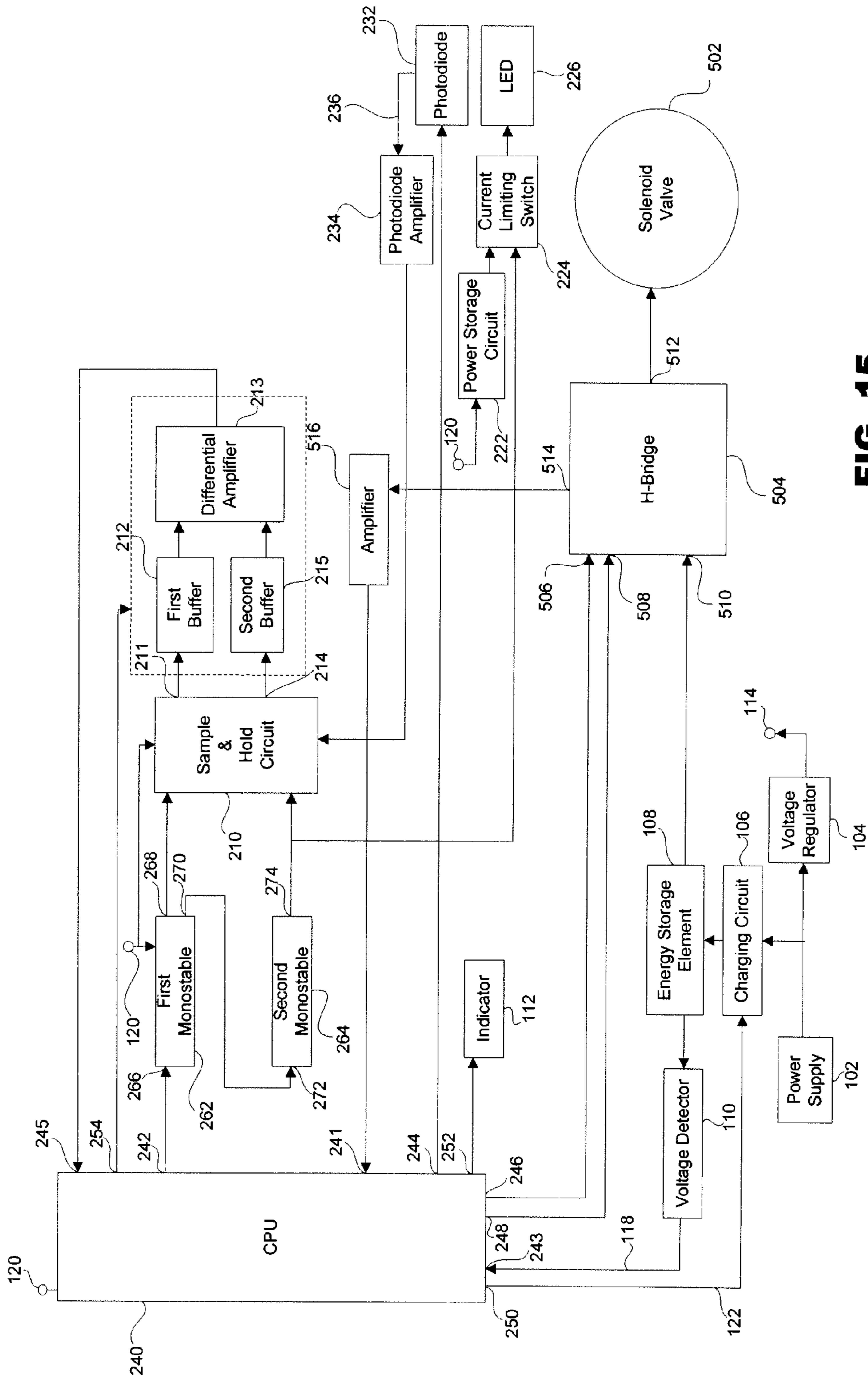


FIG. 15

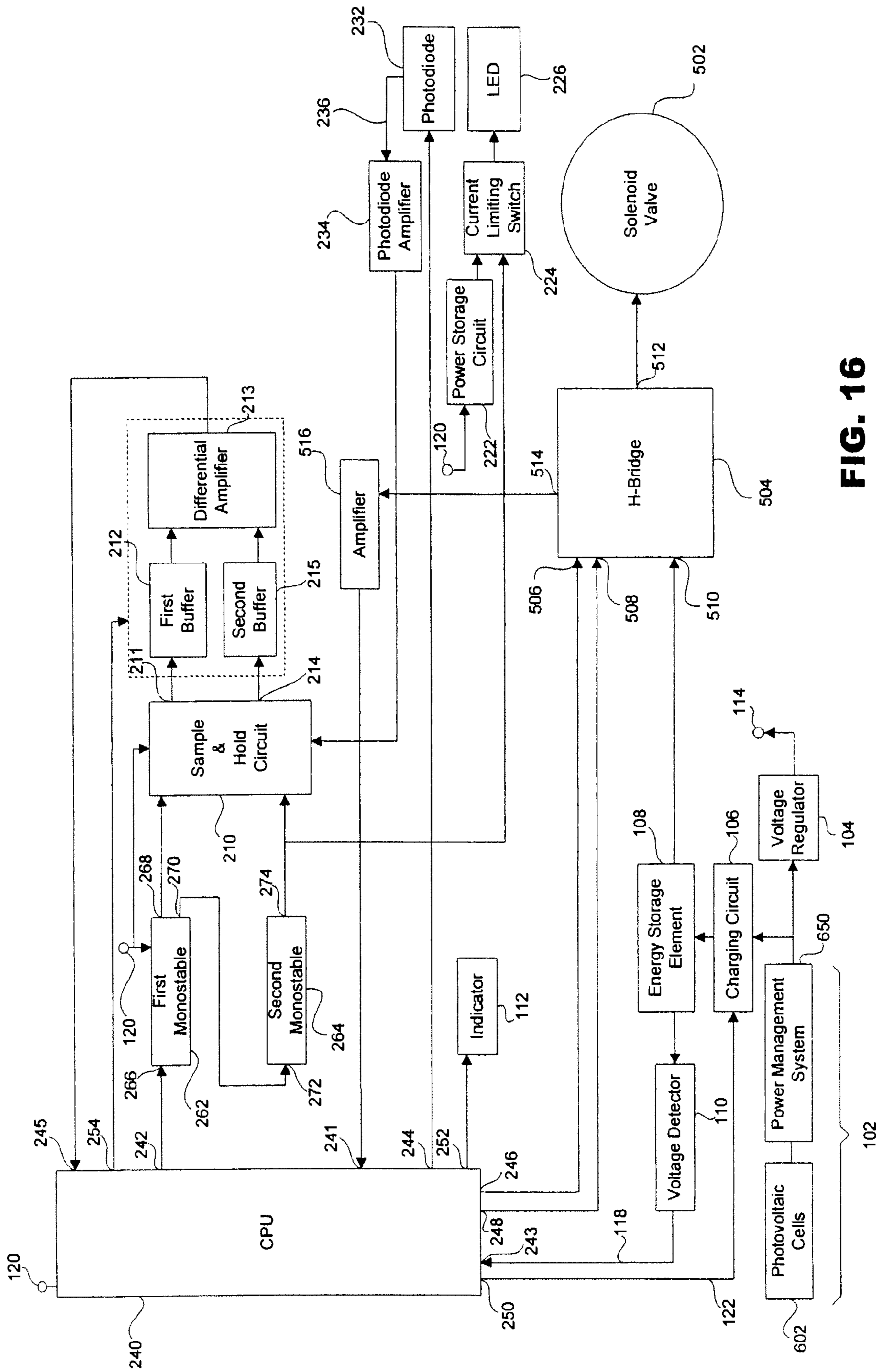
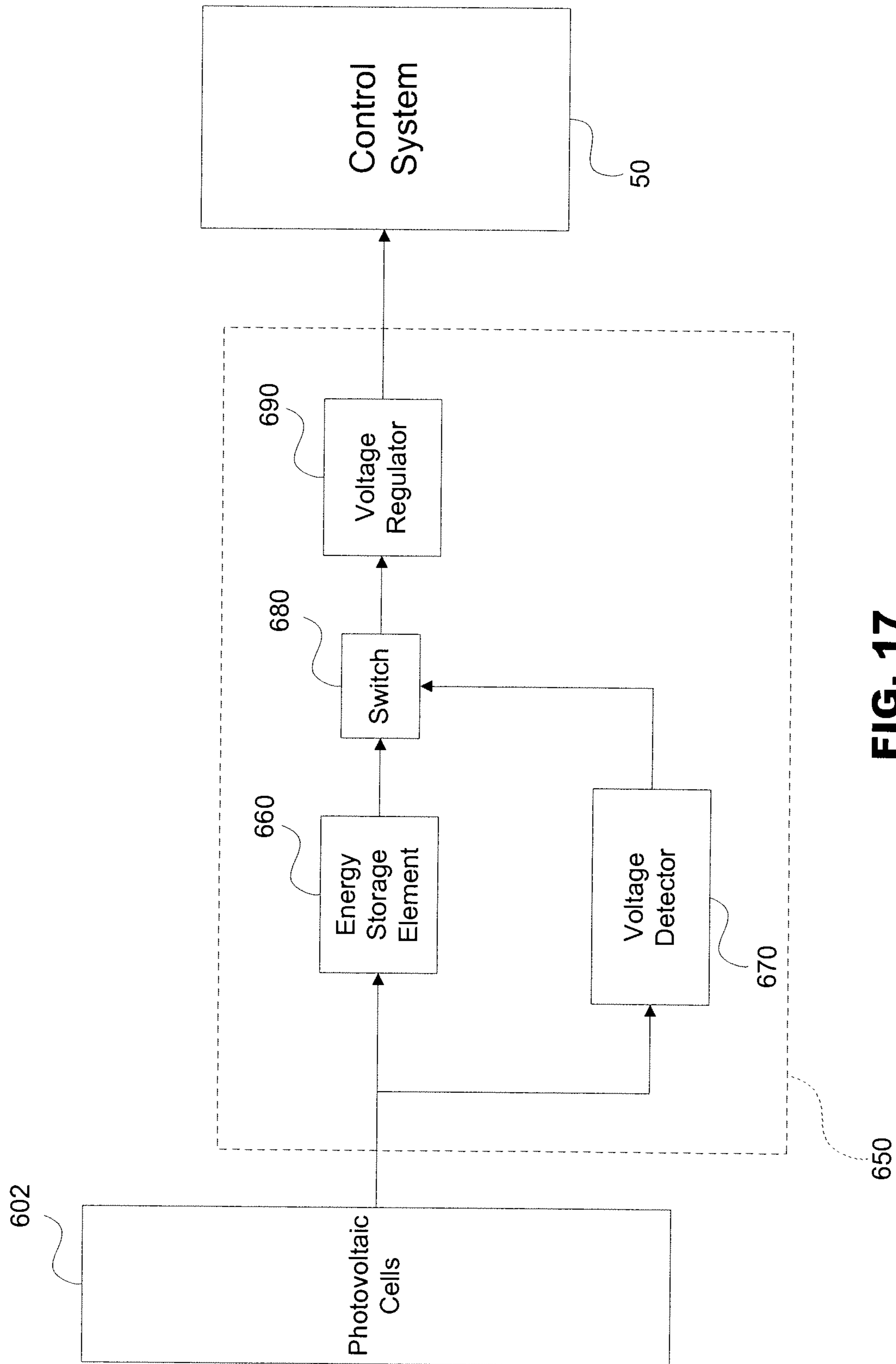


FIG. 16



**FIG. 17**



**1****LAVATORY SYSTEM****CROSS-REFERENCE TO RELATED PATENT APPLICATIONS**

The present application is a continuation of, and claims the benefit of priority as available under 35 U.S.C. §121 to, co-pending U.S. patent application Ser. No. 11/858,800, having a filing date of Sep. 20, 2007, titled "LAVATORY SYSTEM," which is a divisional of U.S. patent application Ser. No. 11/041,882, having a filing date of Jan. 21, 2005, titled "LAVATORY SYSTEM," which claims the benefit under 35 U.S.C. 119(e) of U.S. Provisional Application No. 60/538,583, having a filing date of Jan. 23, 2004, titled "LAVATORY SYSTEM," and which claims the benefit under 35 U.S.C. 119(e) of U.S. Provisional Application No. 60/602,585, having a filing date of Aug. 18, 2004, titled "LAVATORY SYSTEM," the entire disclosures of which are hereby incorporated herein by reference.

**FIELD**

The present inventions relate generally to a lavatory system. The present inventions also relate to a lavatory system having a control system suitable for providing "hands-free" operation of one or more fixtures (e.g., sprayheads, faucets, showerheads, soap or lotion dispensers, hand dryers, flushers for toilets and/or urinals, emergency fixtures, etc.) within the lavatory system. The present inventions further relate to a lavatory system having a photovoltaic system for providing electrical energy one or more electronic fixtures within the lavatory system and/or for providing electrical energy to a control system coupled to the fixtures.

**BACKGROUND**

It is generally known to provide a lavatory system having at least one fixture that conventionally requires manual manipulation by a user in order to operate. It is further known to provide an electrical and/or electronic control system with such a fixture for providing "hands-free" operation of the fixture. Not requiring a user to physically contact or touch the fixture for its operation may be desirable for various sanitary and/or accessibility considerations.

A power source is necessary when using an electronic and/or electrical control system to control a fixture. When available and desirable, power is commonly provided by an AC power line. However, when not available or not desirable, alternative power sources are utilized. Known alternative power sources include energy storage elements such as batteries and capacitors. However, control systems that use such energy storage elements have disadvantages, including having a power source with a relatively finite operating life that often must be periodically changed, reenergized, or otherwise maintained.

It would be advantageous to provide a lavatory system for use in commercial, educational, or residential applications, having one or more fixtures and a control system for enabling "hands-free" operation of the fixtures wherein the control system is powered by means other than an AC power line (e.g., energy storage element, etc.). It would also be advantageous to provide a control system for use with a lavatory system that can prolong the operating life of an energy storage element by reducing or minimizing the required power consumption of the control system. It would further be advantageous to provide a control system that minimizes or reduces power consumption by increasing the speed at which the

**2**

control system processes a signal representative of the environment near the fixture (a sensing region). It would further be advantageous to provide a lavatory system having a photovoltaic system that can provide electrical energy to a control system and/or a fixture of the lavatory system. It would further be advantageous to incorporate photovoltaic cells into the support structure of a lavatory system (such as a usable surface). It would further be advantageous to provide a power management system providing for the efficient use of electrical energy generated by a photovoltaic system.

Accordingly, it would be desirable to provide for a lavatory system having one or more of these or other advantageous features.

**SUMMARY**

An exemplary embodiment relates to a lavatory. The lavatory includes at least one wash station, at least one electrically operated fixture associated with the wash station, a control system configured to control a flow of a fluid through the at least one electrically operated fixture, a power source selectively coupled to the control system, and a power management system coupled to the power source to control the power provided to the control system. The power management system includes a detector configured to monitor the output voltage of the power source, and a switch configured to electrically disconnect the power source from the control system when the output voltage of the power source drops below a predetermined level.

Another exemplary embodiment relates to a control system for use with a lavatory system having at least one wash station and at least one electrically operated fixture. The control system includes a detection system, a fixture actuation system coupled to the detection system and configured to control a flow of a fluid through the fixture based upon a signal received from the detection system, a power source selectively coupled to the detection system, and a power management system coupled to the power source to control the power provided to the detection system. The power management system includes a detector configured to monitor the output voltage of the power source, and a switch configured to electrically disconnect the power source from the control system when the output voltage of the power source drops below a predetermined level.

Another exemplary embodiment relates to a power supply system for a lavatory system having a control system for operating a fixture. The power supply system includes a power source configured to be electrically coupled to the control system and to provide an output voltage. The power supply system also includes a power management system coupled to the power source. The power management system includes a detector configured to monitor the output voltage of the power source, and a switch configured to electrically disconnect the power source from the control system when the output voltage of the power source drops below a predetermined level.

**BRIEF DESCRIPTION OF THE DRAWINGS**

FIG. 1 is a perspective view of a lavatory system according to an exemplary embodiment, shown as a washing station.

FIG. 2 is a perspective view of a lavatory system having a photovoltaic system according to an exemplary embodiment.

FIG. 3 is a top view of the lavatory system of FIG. 2 showing photovoltaic cells coupled to an upper portion of the lavatory system.

3

FIG. 4 is a partially exploded perspective view of the photovoltaic system of FIG. 2.

FIG. 5 is a partial cross section view of the lavatory system shown in FIG. 2 taken along the line 5-5.

FIG. 6 is an exploded perspective view of an upper portion of a lavatory system showing a photovoltaic system according to another embodiment.

FIG. 7 is a partial cross section of the upper portion of the lavatory system shown in FIG. 6 showing a photovoltaic cell unit coupled to the lavatory system.

FIG. 8 is a schematic block diagram a control system for use with the lavatory system shown in FIG. 1 to provide for the operation of the fixtures.

FIG. 9 is a schematic block diagram of a power supply system of the control system shown schematically in FIG. 8 according to an exemplary embodiment.

FIG. 10 is a schematic block diagram of a power supply system of the control system shown schematically in FIG. 8 according to another exemplary embodiment.

FIG. 11 is a schematic block diagram of a detection system of the control system shown schematically in FIG. 8 according to an exemplary embodiment.

FIG. 12 is a schematic block diagram of a transmitter of the control system shown schematically in FIG. 11 according to an exemplary embodiment.

FIG. 13 is a schematic block diagram of a receiver of the control system shown schematically in FIG. 11 according to an exemplary embodiment.

FIG. 14 is a schematic block diagram of a fixture actuation system of the control system shown schematically in FIG. 8 according to an exemplary embodiment.

FIG. 15 is a detailed schematic block diagram of the control system of FIG. 8 according to an exemplary embodiment.

FIG. 16 is a detailed schematic block diagram of the control system of FIG. 8 according to another exemplary embodiment.

FIG. 17 is a detailed schematic block diagram of a power management system of the photovoltaic system of FIG. 16 according to an exemplary embodiment.

#### DETAILED DESCRIPTION

Referring generally to the FIGURES, a lavatory system 10 with components is shown according to exemplary embodiments. FIG. 1 shows lavatory system 10 as a washing station suitable for providing a cleansing area for one or more users. Lavatory system 10 is shown as including a pair of fixtures 14 having outlets (e.g., nozzles, diffusers, etc.) directed towards a basin 18 which is supported by a base or a support structure 12. Support structure 12 is provided an upper portion 16 by which fixtures 14, and/or other components, may be placed upon or coupled thereto. Upper portion 16 is further shown as including a platform or shelf 20 which provides a relatively flat surface (e.g., ledge, countertop, etc.) that can be used by a user to conveniently hold various objects (e.g., toiletries, beverage containers, personal items, etc.).

According to an exemplary embodiment, lavatory system 10 includes a control system 50 for controlling the operation of fixtures 14. Preferably, fixtures 14 are “touchless” fixtures meaning that a user can operate the fixtures without physically contacting the fixtures and/or an interface coupled to the fixtures (i.e., “hands-free” operation). In this manner, lavatory system 10 can overcome sanitation and/or accessibility limitations often associated with conventionally used fixtures. Control system 50 monitors a defined sensing region (an area adequately proximate to fixtures 14 in which a user of the fixture is likely to be positioned) for the presence of an

4

object (e.g., a user, etc.) and controls the operation of fixtures 14 accordingly. FIG. 8 shows a block diagram representative of control system 50 according to an exemplary embodiment. Control system 50 includes a power supply system 100, a detection system 200, and a fixture actuation system 500. Control system 50 is configured to reduce power consumption in an effort to prolong the useful operating life of a power source having an finite operating life (such as a battery). Power consumption is reduced by shortening the time interval (i.e., a sample period) for which detection system 200 is monitoring the sensing region and by increasing a speed at which detection system 200 processes a signal representative of status of the sensing region. Increased processing speed allows detection system 200 to take extended “sleep periods” which conserve power. “Sleep periods” include periods wherein detection system 200 is substantially not consuming any power, and/or periods wherein detection system 200 is consuming a reduced amount of power.

According to another exemplary embodiment, lavatory system 10 includes a photovoltaic system 600 capable of converting light energy to electrical energy. Photovoltaic system 600 can be used to power fixtures 14 and/or a control system providing for the “hands-free” operation of fixtures 14 (such as control system 50). FIGS. 2 through 4 and 16 through 18 show photovoltaic system 600 and components thereof according to exemplary embodiments. Referring particularly to FIG. 2, photovoltaic system 600 is shown as including one or more photovoltaic cells 602 (such as an array of cells) coupled to support structure 12 of lavatory system 10. Photovoltaic cells 602 may be supported by, mounted to, contained within, and/or integrally formed with a portion of support structure 12. Preferably, photovoltaic cells 602 are provided at shelf 20 of upper portion 16 of support structure 12 in an effort to maximize the exposure of photovoltaic cells 602 to the ambient light. Preferably, the addition of photovoltaic cells 602 to shelf 20 does not significantly limit the functionality of shelf 20 as a usable surface for a user.

Photovoltaic cells 602 are electrically coupled to fixtures 14 and/or a control system providing for the operation of fixtures 14. According to an exemplary embodiment, photovoltaic system 600 further includes a power management system 650 providing for an efficient use of the electrical energy generated by photovoltaic cells 602. FIGS. 17 and 18 show power management system 650 and components thereof according to exemplary embodiments. Power management system 650 generally includes an energy storage element 660 configured to receive and store electrical energy generated by photovoltaic cells 602, a detector (shown as a voltage detector 670) for monitoring the level of ambient light surrounding lavatory system 10 (e.g., by monitoring the energy stored in energy storage element 660, etc.) to recognize periods of time when it is unlikely that lavatory system 10 will be used (e.g., when the ambient light is turn off or otherwise reduced), a switch 680 capable of electrically disconnecting energy storage element 660 from control system 50 when voltage detector 670 sends an output signal indicating that given the level of ambient light surrounding lavatory system 10 it is unlikely that lavatory system 10 will be used, and a voltage regulator 690 for adjusting the voltage being sent to control system 50. According to various alternative embodiments, power management system may be used without photovoltaic cells 602 to electrically disconnect an energy storage element (such as a battery) from control system 50.

Referring back to FIG. 1, lavatory system 10, is intended for commercial, educational, medical, and/or residential use and to be readily installed in a number of locations and environments including, but not limited to, restrooms, locker

## 5

rooms, break rooms, surgical prep rooms, kitchens, or the like. For purpose of this disclosure, the phrase “lavatory system” is used generally to refer to any cleansing or other sanitary system or station, and is not intended to be limited to the washing station shown. For example, the various alternative embodiments of lavatory system 10 may include, but are not limited to, toilets, urinals, showers, wash fountains, emergency wash stations (e.g., drench showers, eye wash systems, etc.), or alternative washing stations.

Fixtures 14, shown as a pair of sprayheads, are configured for directionally dispensing (e.g., spraying, discharging, spending, etc.) a fluid (e.g., water, etc.). According to various alternative embodiments, lavatory system 10 may include a variety of other fixtures instead of, or in combination with, fixtures 14 including, but not limited to, faucets, soap or lotion dispensers, hand dryers, showerheads, flushers for toilets and/or urinals, emergency fixtures, etc. Fixtures 14 are shown coupled to support structure 12, but alternatively may be supported relative to lavatory system 10. For example, according to an alternative embodiment, fixtures 14 may be coupled to a structure such as a wall or partition rather than support structure 12. According to a preferred embodiment, fixtures 14 are coupled to upper portion 16 of support structure 12 with their outlets directed in an outwardly and downwardly manner towards basin 18.

Fixtures 14 are adapted for being in fluid communication with a fluid supply via a conduit system (not shown) which is likely to include one or more sections of piping or tubing. Each fixture 14 may be independently coupled to a fluid supply, or alternatively, may be coupled to a common or shared fluid supply (e.g., through use of a manifold, etc.). Preferably lavatory system 10 is a multiple station lavatory system wherein fixtures 14 are sufficiently spaced apart in a lateral direction relative to support structure 12 for providing more than one cleansing area. According to various alternative embodiments, any number of fixtures 14 may be used for providing any number of cleansing areas.

Lavatory system 10 further includes a fluid collection receptacle (shown as wash basin 18) for collecting fluid that is discharged from fixtures 14. Wash basin 18 is likely to include one or more fluid drains 19 (shown in FIG. 3) which allow wash basin 18 to be emptied of fluid collected therein. Preferably, wash basin 18 is a substantially continuous receptacle for servicing both fixtures 14, but alternatively, may be provided as a divided receptacle, or further still, as two separate or isolated receptacles (one for each fixture 14). Wash basin 18 is surrounded by a relatively flat surface (e.g., platform, ledge, countertop, tabletop, etc.), shown as a deck 17. Deck 17 may be integrally formed with wash basin 18 (provided as a one-piece member), or alternatively, may be a separate component. According to various alternative embodiments, fixtures 14 may be coupled to deck 17, which can also be used to support a variety of other fixtures. Wash basin 18 is shown as being supported by support structure 12, but according to an alternative embodiment, may be supported by a partition or any other suitable wall structure.

Support structure 12 is shown as including upper portion 16 and a lower portion 22. Upper portion 16 is positioned above wash basin 18 and is provided with shelf 20. Lower portion 22 is configured to at least partially support deck 17 and/or wash basin 18. Preferably, lower portion 22 is configured to conceal the conduit system fluidly coupling fixtures 14 to the fluid supply. Lower portion 22 may include one or more access panels (such as a cabinet door) for allowing access to the components of lavatory system 10 (e.g., conduit system, fixture control system, etc.). According to various alternative embodiments, lower portion 22 may be eliminated

## 6

if deck 17 and/or wash basin 18 can be sufficiently supported by other means, such as by mounting deck 17 and/or wash basin 18 to a wall in a cantilever manner and/or by supporting deck 17 and/or wash basin 18 with a structure provided from above lavatory system 10.

FIGS. 8 through 16 show control system 50 and components thereof according to exemplary embodiments. Control system 50 provides for the “hands-free” operation of fixtures 14. Control system 50 is a relatively “low” power system that is configured to avoid false readings that limit the effectiveness of conventional control systems. Control system 50 generally includes power supply system 100, detection system 200, and fixture actuation system 500. Power supply system 100 provides an operating voltage to the various elements/components of control system 50, while detection system 200 monitors an area (i.e., sensing region, zone of detection, etc.) adjacent fixture 14 and provides an output signal to fixture actuation system 500 which in turn activates or deactivates a valve (e.g., a solenoid valve 502) for controlling the flow of a fluid through fixtures 14.

Control system 50 can be mounted to lavatory system 10 in a variety of ways and at a variety of positions. Preferably, the majority of the circuitry of control system 50 is provided beneath wash basin 18 and is concealed from the view of a user by lower portion 22 of support structure 12. According to various alternative embodiments, control system 50 may be provided at a position that is remote from lavatory system 10. A sensory window 24 (shown in FIG. 1) is provided on lavatory system 10 to house and/or protect a transmitter 220 and an receiver 230 of detection system 200. Lavatory system 10 is shown as having a separate sensory window 24 for each fixture 14. According to various alternative embodiments, a common sensory window 24 may be provided for housing and/or protecting components of detection system 200 used to control both fixtures 14. Sensory window 24, in combination with transmitter 220 and receiver 230 of detection system 200, define the sensing region in which an object must enter in order for control system 50 to activate fixtures 14. The size of the sensing region can be varied depending on the particular application.

Referring particularly to FIGS. 9, 10, 15 and 16, power supply system 100 generally includes a power source 102, a voltage regulator 104, a charging circuit 106, an energy storage element 108, and a voltage detector 110. Power supply system 100 is configured to provide a first output, shown as a system supply voltage 114, for providing electrical energy to components of detection system 200, a second output, shown as a fixture supply voltage 116, for providing electrical energy to fixture actuation system 500, and a third output, shown as a status signal 118, representative of power level of energy storage element 108. According to various alternative embodiments, power supply system 100 may include any number of outputs depending upon the requirements of control system 50 and/or lavatory system 10.

Control system 50 is advantageously configured for use in applications for which access to a conventional AC power line (requiring a hard-wired connection) is not readily available or is otherwise undesirable to use (e.g., not cost effective to access, etc.). While a conventional AC power line may be used alone or in combination as power source 102, preferably power source 102 is an energy storage element having a relatively finite service or operating life such as a battery, a photovoltaic cell energizing a capacitor (shown in FIG. 10), or the like. According to a one embodiment, power source 102 is a lithium battery having a voltage between approximately 4 volts and approximately 7 volts. According to various alternative embodiments, power source 102 may be provided by

any suitable battery having a range of suitable voltages, and/or may further include a supplemental (e.g., secondary, etc.), a startup, and/or a backup power source.

According to a particularly preferred embodiment, power source **102** has an output voltage of approximately 7 volts. Voltage regulator **104** is configured to adjust the output voltage of power source **102** to a predetermined operating voltage that is compatible with the components of detection system **200** before the electrical energy is outputted as system supply voltage **114**. According to an exemplary embodiment, voltage regulator **104** provides a relatively stable operating voltage of approximately 3.3 volts that is subsequently distributed as system supply voltage **114** to various components of control system **50** requiring electrical energy (shown as system supply voltage inputs **120**). According to various alternative embodiments, voltage regulator **104** may be eliminated if the voltage of power source **102** equals the voltage needed for system supply voltage **114**.

Fixture supply voltage **116** (the second output voltage of power supply system **100**) provides an operating voltage for the activation and deactivation of a valve controlling the flow of a fluid from fixtures **14**. Fixture supply voltage **116** is outputted from energy storage element **108**, which is preferably provided by a storage capacitor. Energy storage element **108** stores electrical energy until needed to actuate the valve controlling the flow of the fluid from fixtures **14**. According to an exemplary embodiment, energy storage element **108** has a capacitance of between approximately 10 millifarads (mF) to approximately 10 F. According to a preferred embodiment, energy storage element **108** is provided by a single super capacitor having a capacitance of approximately 60 mF, but alternatively, may be provided by a plurality of capacitors (the combination of which provides the desired capacitance and voltage rating). According various alternative embodiments, energy storage element **108** may be configured to have a variety of capacitances depending upon the particular application.

To ensure that energy storage element **108** contains a sufficient amount of electrical energy to turn fixtures **14** on and/or off (i.e., enough electrical energy to actuate a solenoid valve **502**), voltage detector **110** is provided for monitoring the power level of energy storage element **108**. Voltage detector **110** monitors energy storage element **108** to ensure that the voltage of energy storage element **108** does not drop below a preset threshold or baseline voltage. According to a preferred embodiment, the baseline voltage of energy storage element **108** is set at approximately 4.5 volts (meaning that if the voltage of energy storage element **108** drops below 4.5 volts, energy storage element will be charged sufficiently charged).

Voltage detector **110** sends status signal **118** (the third output of power supply system **110**) to detection system **200**, preferably a computing device (shown as a central processing unit (CPU) **240**) of detection system **200**, representative of power level of energy storage element **108**. If status signal **118** indicates that the power level of energy storage element **108** has dropped below the preset baseline voltage, CPU **240** sends an output signal **122** to charging circuit **106** which is in turn activated to charge energy storage element **108**. Power supply system **100** may optionally include an indicator **112** (shown in FIGS. **12** and **13**) to provide for a visual display (e.g., a continuous or flashing light, etc.) when energy storage element **108** is being charged by charging circuit **106**.

Referring generally to FIGS. **11** through **13**, **15**, and **16**, detection system **200** generally includes a computing device (shown as a central processing unit (CPU) **240**) and a sample and hold circuit **210** to which a sensory device with a trans-

mitter **220** and a receiver **230** is connected thereto. Detection system **200** further includes a pulse regulator circuit **260** for shortening the time interval of the sample period. Detection system **200** monitors the sensing region and provides output signal to fixture actuation system **500** indicating whether solenoid valve **502** should be opened or closed.

Referring particularly to FIGS. **11** and **15**, CPU **240** is configured to support and execute a program to control the components of control system **50**. CPU **240** is powered by system supply voltage **114** and is shown as having a first output **242** for controlling transmitter **220**, a second output **244** for sending an operating voltage to receiver **230**, a third output **246** for providing a "valve closed" signal to fixture actuation system **500**, a fourth output **248** for providing a "valve open" signal to fixture actuation system **500**, a fifth output **250** for controlling charging circuit **106** of power supply system **100**, a sixth output **252** for activating indicator **112** when charging circuit **106** is charging energy storage element **108**, and a seventh output **254** for providing an operating voltage to components of detection system **200**. CPU **240** is further shown as having a first input **241** representative of the operating state of fixtures **14**, a second input **243** representative of the voltage level of energy storage element **108**, and a third input **245** representative of the level of infrared light within the sensing region. According to various alternative embodiments, CPU **240** may include any number of outputs and inputs to meet the requirements of the particular application.

CPU **240** is configured to operate at a relatively fast processing speed in comparison to CPUs used in known control systems which also rely upon a power source having a relatively finite operating life. By utilizing a CPU having a relatively fast processing speed, control system **50** is able to conserve power. Although a faster CPU requires more power than conventionally used CPUs (those having a clock rate of less than 32 kHz), the faster CPU is able to process third input **245** and compare that value with an established baseline value to determine what output (third output **246** or fourth output **248**), if any, should be sent to fixture actuation system **500** faster than conventionally used CPUs.

According to an exemplary embodiment, CPU **240** has a clock rate greater than approximately 32 kilohertz (kHz). According to a preferred embodiment, CPU **240** has a clock rate within the range of approximately 32 kHz to approximately 20 megahertz (MHz). According to a particularly preferred embodiment, CPU **240** has a clock rate of approximately 4 MHz. Since a 4 MHz CPU can process and compare the signal faster than a 32 kHz CPU, the sleep period of the 4 MHz CPU will be longer than that of the 32 kHz CPU. A longer sleep period will prolong the operating life of energy storage element **108**. The sleep period may include periods wherein CPU **240** requires substantially no power and/or periods wherein CPU **240** requires a reduced amount of power. For example, CPU **240** may be configured to operate between varying frequencies rather than just between an "on" and "off" operational state. Accordingly, CPU **240** may have a clock rate of 4 MHz while a sample of the sensory region is being obtained, while having a clock rate of only 32 kHz between sampling periods to allow for reduced power consumption. In such a configuration, the period during which the 4 MHz CPU operated at 32 kHz may constitute the sleep period.

Referring generally to FIGS. **11** through **13**, **15**, and **16**, transmitter **220** is configured to emit a signal into the sensing region, while receiver **230** is configured to measure (e.g., capture, monitor, etc.) the signal in the sensing region. Preferably, transmitter **220** is configured to emit pulses of infrared

light into the sensing region, while receiver 230 is configured to measure the level of infrared light in the sensing region. According to various alternative embodiments, transmitter 220 and receiver 230 may be configured as a radar sensor, a sonar sensor, or any other suitable sensory device.

Receiver 230 may be operated independently of transmitter 220 (to measure a background level of infrared light) and/or may be operated in conjunction with transmitter 220 (to measure the amount of reflected infrared light in the sensing region to detect the presence of an object (e.g., a user)). When a user enters the sensing region, at least a portion of the infrared light emitted from transmitter 220 will be reflected by the user and detected by receiver 230. A signal representative of the level of infrared light in the sensing region is sent to CPU 240 which in turn uses the signal to determine whether fixture actuation system 500 should be actuated. If an object is detected, CPU 240 will send a signal from output 248 to fixture actuation system 500 to activate a valve (e.g., solenoid valve 502) allowing for the flow of a fluid from at least one of fixtures 14.

Referring particularly to FIG. 12, transmitter 220 is shown as including a power storage circuit 222, a current limiting switch 224, and an light emitting diode (LED) 226. Power storage circuit 222 receives and stores a sufficient amount of power for activating LED 226. According to an exemplary embodiment, power storage circuit 222 includes a capacitor that is charged by system supply voltage 114 outputted by power supply system 100. Current limiting switch 224 is provided for regulating the maximum current being provided to LED 226. According to an exemplary embodiment, current limiting switch 224 limits the current going to LED 226 to between approximately 700 and 800 milliamperes.

According to an exemplary embodiment, one transmitter 220 having one LED 226 is provided for each fixture 14. According to various alternative embodiments, any number of transmitters 220 (having any number of LEDs 226) can be used to emit pulses of infrared light into the sensing region of the respective fixture 14. According to an exemplary embodiment, LED 226 is supported at a position above fixtures 14 so that a fluid flow discharging from fixtures 14 does not interfere with (e.g., reflect, etc.) the pulses of infrared light being emitted by LED 226. Preferably, LED 226 is protected behind sensory window 24 (see FIGS. 1 and 2) that is provided in upper portion 16 of support structure 12. The placement of LED 226 and/or sensory window 24 and the method of supporting LED 226 and/or sensory window 24 relative to support structure 12 may change depending on the fixtures and configuration of lavatory system 10.

Referring particularly to FIG. 13, receiver 230 is shown as including a photodiode 232 and a photodiode amplifier 234. Photodiode 232 captures the level of infrared light in the sensing region (including levels of infrared light in the ambient light and/or levels of infrared light from transmitter 220). According to an exemplary embodiment, photodiode 232 is positioned adjacent to LED 226. According to various alternative embodiments, receiver 230 may include any number of photodiode 232 for capturing the level of infrared light in the sensing region, and can be positioned near and/or at a distance from LED 226. Photodiode 232 generates an output signal 236 representative of level of infrared light in the sensing region. Output signal 236 is fed into photodiode amplifier 234, which is configured to amplify the current coming from photodiode 232 (output signal 236) into an analog voltage and to provide buffering for the resultant signal. The analog voltage representative of the level of infrared light in the sensing region is then sent to sample and hold circuit 210.

Referring to FIGS. 11, 15, and 16, sample and hold circuit 210 is configured to receive and store a first voltage representative of the level of infrared light in the sensing region when transmitter 220 is not activated and a second voltage representative of the level of infrared light in the sensing region when transmitter 220 is activated. Sample and hold circuit 210 is shown as including a first output 211 for outputting the first voltage to a first buffer 212 and subsequently a difference amplifier 213. Sample and hold circuit 210 is further shown as including a second output 214 for outputting the second voltage to a second buffer 215 and subsequently difference amplifier 213. Sample and hold circuit 210 includes one capacitor and one corresponding switch for each the first voltage (representative of the level of infrared light in the sensing region when transmitter 220 is not activated) and the second voltage (representative of the level of infrared light in the sensing region when transmitter 220 is activated). Preferably, the storage capacitors of sample and hold circuit 210 are relatively small so that the capacitors can charge quickly thereby allowing the input signals from photodiode amplifier 234 to be continually recognized. According to a particularly preferred embodiment, storage capacitors having a capacitance of approximately 1000 picofarads (pF) are used for the storage capacitors of sample and hold circuit 210. According to various alternative embodiments, storage capacitors having other capacitances may be used.

Referring still to FIGS. 11, 15, and 16, pulse regulator 260 establishes the time interval of a sample period for sample and hold circuit 210. For purposes of this disclosure, the term "sample period" is used generally to refer to the period of time needed for sample and hold circuit 210 to capture and hold both the background level of infrared light and the background level of infrared light plus the reflected level of infrared light. Pulse regulator 260 provides for a shortened sample period (a sample period of approximately 1.5 microseconds ( $\mu\text{s}$ )) that advantageously allows lavatory system 10 to be used in environments wherein the ambient light and/or other signal transmitters at least periodically emit levels of infrared light. For example, it is generally known to use fluorescent lamps having a frequency range between 50 Hertz (Hz) and 110 kilohertz (kHz). If a measurement of the sensing region is taken over a relatively long period of time, the measurement may include a high peak value and a low peak value of the fluorescent light which may cause control system 50 to misinterpret the change in the level of infrared light in a sensing region. Shortening the sample period decreases the likelihood of a false reading caused by interfering infrared light.

Pulse regulator 260 is shown as generally including a first monostable 262 and a second monostable 264. First monostable 262 includes an input 266 for receiving a signal from output 242 of CPU 240 for starting a timing period, a first output 268 for sending a signal to sample and hold circuit 210, and a second output 270 for providing a signal to second monostable 264. Second monostable 264 includes an input 272 for receiving a signal from second output 270 from first monostable 262 and an output 274 for providing a signal to sample and hold circuit 210 and transmitter 220. Together, first monostable 262 and second monostable 264 provide a dual monostable multivibrator between an output pulse from CPU 240 and transmitter 220 for shortening the sample period.

Referring particularly to FIGS. 14 through 16 fixture actuation system 500 receives an input signal from detection system 200 indicating whether to change the operating state of fixtures 14. Fixture actuation system 500 is shown as generally including a valve, shown as a solenoid valve 502, fluidly coupled to a fluid line between the fluid source and the outputs

of fixtures **14**. Solenoid valve **502** switches between an first or open position, wherein fluid is able to discharge from fixtures **14**, and a second or closed position, wherein solenoid valve **502** is configured to block the fluid line to prevent fluid from discharging from fixtures **14**.

According to a preferred embodiment, solenoid valve **502** is a latching valve including a cylinder enclosing a piston having a plunger disposed around a first end and a magnet positioned at the top of the first end. In the closed position, the plunger is seated against a diaphragm to prevent fluid from exiting fixture **14**. In the open position, the plunger is unseated from the diaphragm and moved towards the top of the cylinder to allow for the flow of a fluid. The plunger is held in the open position by the magnet.

Fixture actuation system **500** is further shown as including a switching device, shown as an H-Bridge **504**, for controlling the positioning of solenoid valve **502** by reversing the polarity of the current sent to solenoid valve **502** from energy storage element **108**. H-Bridge **504** is shown as including a first input **506** for receiving the “valve close” signal from output **246** of CPU **240**, a second input **508** for receiving the “valve open” signal from output **248** of CPU **240**, and a third input **510** for fixture supply voltage **116** from energy storage element **108** of power supply system **100**. H-Bridge **504** is further shown as including a first output **512** for providing a signal to solenoid valve **502** and a second output **514** for providing a signal to CPU **240** representative to the operational state of solenoid valve **502**. Before reaching CPU **240**, the signal passes through an amplifier **516**.

According to various alternative embodiments, CPU **240** may be configured for providing “valve open” signal to H-Bridge **504** without providing a “valve closed” signal. In this manner, solenoid valve may be closed by utilizing a timer to control the duration that solenoid valve **502** in the open position.

Operation of control system **50** is described according to a particularly preferred embodiment with reference to lavatory system **10**. In operation, CPU **240** supports and executes a program to control the components of control system **50** by performing a series of statuses in a continuous loop. Upon startup, CPU **240** enters an initial status (e.g. power up, startup, etc.) wherein CPU **240** ensures that solenoid valve **502** is in the second or closed position so that fluid is not being discharged from fixtures **14**. CPU **240** ensures that solenoid valve **502** is in the closed position by providing the “closed valve” signal from output **246** to H-Bridge **504** of fixture actuation system **500**. During this initial status, CPU **240** further receives an input signal (status signal **118**) from voltage detector **110** indicating whether energy storage element **108** is sufficiently charged to actuate solenoid valve **502** (e.g., has a voltage of at least 4.5 volts, etc.) or is in need of charging. If the energy level of energy storage **108** is below the preset baseline voltage stored within CPU **240**, CPU **240** provides a signal from output **250** to charging circuit **106** indicating that charging circuit **106** should be activated for charging energy storage element **108**. Energy storage element **108** should be charged an amount sufficient to provide for multiple actuations of solenoid valve **502**. While charging circuit **106** is charging energy storage element **108**, CPU **240** sends signal from output **252** to activate indicator **112** to provide for a visual display that energy storage element **108** is being charged.

Once energy storage element **108** is sufficiently charged (registers a voltage greater than approximately 4.5 volts), and solenoid valve **502** is placed in the closed position, detection system **200** establishes a baseline infrared light level for the sensing region that will stored in CPU **240** and which will be

compared to later obtained signals to determine if an object is within the sensing region. The baseline infrared light level of the sensing region is established by taking a sensing sample (i.e., comparing the background level of infrared light in the sensing region with the reflected level of infrared light in the sensing region) or a number of sensing samples which is then stored in CPU **240**. According to a particularly preferred embodiment, CPU **240** is powered approximately every 0.25 seconds to check the charge on energy storage element **108** and the level of infrared light in the sensing region and adjust the baseline value accordingly.

CPU **240** then enters a status referred to as a sensing cycle. During the sensing cycle, CPU **240** checks the charge of energy storage element **108** and depending upon the charge turns charging circuit **106** on or off. CPU **240** also checks the duration of time it has been since that last activation of solenoid valve **502** to adjust the time interval between sample periods accordingly. According to a particularly preferred embodiment, if solenoid valve **502** has been activated within 30 minutes, a sample of the sensing region will be taken every 0.25 seconds. However, if solenoid valve **502** has not been activated for a period greater than 30 minutes, CPU **240** will take a sample of the sensing region approximately every second in an effort to reduce power consumption. According to various alternative embodiments, CPU **240** may be programmed in a variety of ways in order to minimize power consumption when fixtures **14** have not been in use for extended periods of time.

CPU **240** then detects whether the level of infrared light in the sensing region has changed relative to the baseline value that is stored in CPU **240**. Once the level of infrared light in the sensing region changes by a predetermined amount (i.e., an indication that an object is within the sensing region), CPU **240** sends the appropriate output signal (either a signal from output **248** to open solenoid valve **502** or a signal from output **246** to close solenoid valve **502**).

During one sensing cycle, CPU **240** sends a signal from output **242** to first monostable **262**. Upon receiving a signal from output **242** of CPU **240**, first monostable **262** starts a timing period. According to an exemplary embodiment, the start of the timing period closes a first switch of sample and hold circuit **210** (a switch between photodiode amplifier **234** and a first capacitor of sample and hold circuit **210**). Once the first switch is closed, photodiode amplifier **234** provides an output voltage representative of the background level of infrared light in the sensing region to the first capacitor of sample and hold circuit **210**. At this point, LED **226** of transmitter **220** is not emitting a pulse of infrared light and therefore the only infrared light being detected and captured by receiver **230** is from the ambient light or other sensing signals in the sensing region.

First monostable **262** latches the background infrared level when first output **268** from first monostable **262** goes low. When first output **268** goes low, second output **270** from first monostable **262** goes high which triggers second monostable **264**. Upon activation, second monostable **264** provides a signal from output **274** which activates transmitter **220** and closes a second switch of sample and hold circuit **210** (a switch between photodiode amplifier **234** and a first capacitor of sample and hold circuit **210**) to store the output voltage coming out of photodiode amplifier **234** (i.e. the output voltage represents the background level of infrared light). The second switch is held closed for a time interval sufficient to provide a control pulse to transmitter **220**. According to an exemplary embodiment, the second switch is held closed for a period of approximately 1.5  $\mu$ s. At the same time, LED **226** of transmitter **220** emits pulses of infrared light into the sens-

ing region. After approximately 1.5  $\mu$ s, the second switch of sample and hold circuit **210** is opened and LED **226** is turned off. Advantageously, the sample period is therefore accomplished in a relatively short period (i.e. approximately 1.5 s).

There are two outputs from sample and hold circuit **210** (first output **211** and second output **214**). First output **211** outputs the voltage stored in the first capacitor representative of the background level of infrared light (i.e., the level of infrared light in the sensory region when transmitter is not activated). Second output **214** outputs the voltage stored in the second capacitor representative of the background level of infrared light plus the level of infrared light while LED **226** was emitting pulses of infrared light. First output **211** and second output **214** are buffered through their respective buffers **212**, **215** and subsequently fed into difference amplifier **213**. Out of difference amplifier **213**, a voltage representing only the reflected level of infrared light that was measured is provided. That value is fed into input **245** of CPU **240** for comparison with the baseline value stored therein. The value is held long enough by CPU **240** so that CPU **240** can measure the voltage (compare the reflected level of infrared light with the baseline value). According to an preferred embodiment, CPU **240** takes approximately 19 s to determine whether the reflected level of infrared light is higher than the established baseline value and whether a signal should be sent to fixture actuation system **500**.

In comparing the reflected level of infrared light with the baseline value, CPU **240** is programmed to recognize a slight increase in the infrared level as only a drift which can be used to adjust the baseline level. If a large increase in reflected infrared light is detected (e.g. when an object is within the sensing region), CPU **240** sends a signal from output **248** to fixture actuation system **500** to activate solenoid valve **502**.

The acquisition of the reflected level of infrared light takes about 1 millisecond (ms). After that period CPU **240** is turned off until the next cycle. According to a preferred embodiment, CPU **240** is turned off for approximately 0.25 seconds. As a result, CPU **240** is on for approximately 1 millisecond (ms) and is off for 250 ms. This is possible because of the shorten sample period for measuring the sensing region (e.g. 1.5 s). The remainder of the time is due to the power up time of the other components (e.g., photodiode amplifier takes about 100  $\mu$ s to get a stable output value). Advantageously, control system **50** is conserving power during the 250 ms sleep period. If LED **226** remains on for a longer sample period (e.g., a sample period of 9  $\mu$ s or greater), LED **226** will undesirably consume more power.

To activate solenoid valve **502**, CPU **240** sends a signal from output **248** to H-Bridge **504** indicating that solenoid should be moved to the open position. H-bridge **504** further receives fixture supply voltage **116** from energy storage element **108** of power supply system **100** for providing the necessary electrical energy to move solenoid valve **502**. H-bridge **504** flips the polarity of current coming from energy storage element **108** to open solenoid valve **502**. According to an exemplary embodiment, solenoid valve **502** will remain open until the "closed valve" signal is sent by CPU **240** (when the level of infrared light measured in the sensing region indicate that a user is no longer present). Control system **50** may optionally include a timer configured to send a signal to H-Bridge **504** indicating that solenoid valve **502** should be moved to the closed position after an established period of time, even if the "closed valve" signal is not sent by CPU **240**.

FIGS. **2** through **7**, **10**, and **16** through **18** show photovoltaic system **600** and components thereof according to exemplary embodiments. Photovoltaic system **600** capable of converting ambient light energy into electrical energy that can be

used to power a fixtures **14**, and/or a control system coupled to fixtures **14** (such as control system **50**). Photovoltaic system **600** generally includes one or more photovoltaic cells **602** configured to convert ambient light energy into electrical energy and a power management system **650** providing for an efficient use of the electrical energy generated by photovoltaic cells **602**. FIG. **16** shows photovoltaic system **600** is as power source **102** of power supply system **100** of control system **50**.

Referring particularly to FIGS. **2** through **7**, photovoltaic system **600** includes one or more photovoltaic cells **602** (e.g., panels, elements, etc.), shown as an array of photovoltaic cells **602**, that are capable of converting energy from ambient light into electrical energy. Depending on the particular location of lavatory system **10**, ambient light may include artificial light (e.g., fluorescent, incandescent, halogen, etc.), natural light (sunlight), or a combination of artificial and ambient light. Preferably, photovoltaic cells **602** are capable of converting varying wavelengths of light into electrical energy (e.g., artificial light and natural light), but alternatively may be selected for being able to convert particular wavelengths of light into electrical energy. Photovoltaic system **600** represents an alternative power source to an AC power line. Unlike an energy storage element (e.g., a battery), photovoltaic system has a relatively infinite life so long as there is sufficient intensity of ambient light.

Photovoltaic cells **602** are coupled to lavatory system **10** at a position (e.g., location, orientation, etc.) that exposes photovoltaic cells **602** to ambient light, and preferably, at a position that maximizes their exposure to ambient light. Photovoltaic cells **602** may be supported by, mounted to, contained within, and/or integrally formed with a portion of lavatory system **10**. Photovoltaic cells **602** may be provided at a variety of positions including, but not limited to, support structure **12**, fixtures **14**, deck **17**, and/or basin **18**. According to various alternative embodiments, photovoltaic cells **602** may be positioned at a distance away from lavatory system **10**. For example, photovoltaic cells **602** may be provided on a wall, partition, a mirror, etc. and electrically coupled to fixtures **14** and/or control system **50** via a suitable wiring configuration.

According to a preferred embodiment, photovoltaic cells **602** are coupled to a relatively flat surface of lavatory system **10** (e.g., shelf **20**, etc.) that is likely to be laterally incident with the ambient light (i.e., perpendicular with the ambient light), but alternatively, may be positioned in any of a variety of positions, angles, and/or orientations depending on the application. According to a further alternative embodiment, photovoltaic cells **602** may be coupled to a curved surface such as a basin **18**, and/or a curved ledge or platform.

The configuration of lavatory system **10** (such as size and shape) will likely dictate the locations at which photovoltaic cells **602** will be positioned. FIG. **2** shows photovoltaic cells **602** coupled to lavatory system **10** at a raised (e.g., elevated, heightened, offset, etc.) position relative to the other components of lavatory system **10**. Photovoltaic cells **602** are shown coupled to shelf **20** of support structure **12** which is positioned above fixtures **14**. Shelf **20** is an elevated surface that is not likely to have a relatively permanent obstruction (e.g., fixture, support structure, etc.) positioned between its top surface and the ambient light source which may limit the exposure of photovoltaic cell **602** to the ambient light source.

FIG. **3** is a top view of lavatory system **10** showing photovoltaic cells **602** coupled to shelf **20**. Photovoltaic cells **602** are shown as being divided into three groups or segments of photovoltaic cells, but alternatively, may be provided as one continuous segment of photovoltaic cells or as individual photovoltaic cells. The number of photovoltaic cells **602**

15

coupled to lavatory system 10 may vary depending on a number of factors including, but not limited, the available surface area of lavatory system 10 capable of accepting photovoltaic cells 602, the power requirements of the control system and/or fixtures 14, the output and efficiency of photovoltaic cells 602, and/or aesthetic considerations.

According to an exemplary embodiment, it is desirable to maximize the number of photovoltaic cells 602 used with lavatory system 10 as is reasonably practical. For example, still referring to FIG. 3, photovoltaic cells 602 cover a substantial portion of the surface area of shelf 20. According to various alternative embodiments, the number of photovoltaic cells 602 used may be limited rather than maximized. The use of commercially available photovoltaic cells 602 (e.g., photovoltaic cells have an established size) may constrain the number of photovoltaic cells coupled to lavatory system 10.

FIGS. 4 and 5 show a method of coupling photovoltaic cells 602 to lavatory system 10 according to an exemplary embodiment. Referring particularly to FIG. 4, shelf 20 is shown having an aperture (e.g., cavity, opening, channel, depression, etc.), shown as a recess 142, configured to receive photovoltaic cells 602. Shelf 20 may be formed (e.g., molded, cast, manipulated, etc.) with recess 142, or alternatively, material may be removed (e.g., milled, cut, drilled, shaved, etc.) from shelf 20 to provided recess 142. Preferably, recess 142 has a depth sufficient so that when photovoltaic cells 602 are positioned therein, the tops of photovoltaic cells 602 do not outwardly extend above the top surface of shelf 20. Such a configuration may allow for a relatively continuous surface once photovoltaic cells 602 are covered by a suitable coating.

Photovoltaic cells 602 are shown to include wires 605 used to electrically couple photovoltaic cells 602 to fixtures 14 and/or a control system for controlling fixtures 14 or some other component of lavatory system 10. Preferably recess 142 includes an opening for allowing wires 605 to be routed to the desired location while concealing wires 605 from the view of a user.

FIG. 5 shows photovoltaic cells 602 as being coupled to shelf 20 via a relatively clear (e.g., transparent, translucent, etc.) sealer or coating, shown as a resin 603. The coating may include, but is not limited to, an epoxy, a polyester resin, or any other suitable material that can be added to recess 142 for coupling photovoltaic cells 602 and will allow for sufficient levels of ambient light to pass through to photovoltaic cells 602. In such a configuration, photovoltaic cells 602 are substantially integrally formed with shelf 20. Shelf 20 may in turn be permanently coupled to upper portion 16 of support structure 12, or alternatively, may be detachably coupled so that shelf 20 can be readily removed in the event that photovoltaic cells 602 need to be replaced and/or repaired.

According to an exemplary embodiment, resin 603 is added to recess 142 to couple photovoltaic cells to shelf 20. Preferably, resin 603 is disposed on the tops of photovoltaic cells 602 to provide protection. According to a particularly preferred embodiment, a first layer of resin 603 is disposed between photovoltaic cells 602 and shelf 20 and a second layer of resin 603 is disposed on top of photovoltaic cells. Such a configuration may help maintain the position and/or the integrity of photovoltaic cells 602 as resin 603 is added (e.g., poured, etc.) over the tops of photovoltaic cells 602. After resin 603 is allowed to harden, resin 603 is preferably finished so that resin 603 is substantially even in height with the top surface of shelf 20. According to various alternative embodiments, resin 603 may only be applied over the tops of, along the sides of, and/or beneath photovoltaic cells 602.

According to an alternative embodiment, photovoltaic cells 602 may be mounted to shelf 20. Photovoltaic cells 602

16

may be directly mounted to shelf 20, or alternatively, may be indirectly mounted to shelf 20. Photovoltaic cells 602 may be mounted to shelf 20 using any of a variety of suitable methods including, but not limited to, mechanical fasteners (e.g., clips, screws, staples, brackets, collars, cover plates, etc.), adhesives, and/or any suitable welding process. The mounting of photovoltaic cells 602 may be intended to be relatively permanent, or alternatively, may be intended to be removable so that photovoltaic cells 602 readily removed and replaced (or repaired) if damaged.

To protect photovoltaic cells 602 from contaminants and/or manipulation (e.g., vandalism), a relatively clear member may be disposed over photovoltaic cells 602. For example, a relatively clear (e.g., transparent, translucent, etc.) glass member or plastic member (e.g., acrylic, etc.) may be disposed over photovoltaic cells 602. Such a member may also be configured to at least partially secure photovoltaic cells 602 to shelf 20. The member may be a relatively rigid member, or alternatively may be a relatively flexible member such as a flexible film, or some other suitable material.

FIGS. 6 and 7 show a method of coupling photovoltaic cells 602 to lavatory system 10 according to another exemplary embodiment. Lavatory system 10 is shown as being configured to support one or more photovoltaic cell packages or units comprising a receptacle (shown as a relatively shallow pan or tray 604). Tray 604 is sized and dimensioned to receive one or more photovoltaic cells 602. Photovoltaic cells 602 are coupled to tray 604, which is in turn coupled to lavatory system 10.

Trays 604 may be permanently coupled to lavatory system 10 or detachably coupled to lavatory system 10. The use of photovoltaic cell units may provide for modularity in lavatory system 10, and allow photovoltaic cells 602 to be readily installed, removed, and/or interchanged. Such a configuration may allow photovoltaic cells 602 to be efficiently removed in the event that photovoltaic cells 602 are to be repaired or replaced. Preferably, the photovoltaic cell units are coupled to lavatory system 10 from an area generally not accessible to a user (e.g., from the bottom of shelf 20) in an attempt to protect from (or minimize the effect of) tampering and/or vandalism and/or other known harm to photovoltaic cells 602.

Tray 604 is shown as being coupled to shelf 20 of support structure 12 and received within recess 142. Referring to FIG. 7, photovoltaic cells 602 are coupled to tray 604 using resin 603. According to a preferred embodiment, photovoltaic cells 602 are inserted in tray 604 and resin 603 is disposed over the tops of photovoltaic cells 602 and allowed to harden. The resultant photovoltaic cell units may then be coupled to shelf 20.

FIGS. 10 and 16 show a block diagram of control system 50 incorporating photovoltaic system 600 as power source 102. It should be noted that photovoltaic system 600 not limited in application to control system 50 or other control systems designed to provide for "hands free" operation of a fixture. According to various alternative embodiments, photovoltaic system 600 may be used in combination with other forms of control systems and/or fixtures requiring or using electric energy in order to operate (or assist in operation). For example, photovoltaic system 600 may be configured to provide electrical energy to a control system coupled to a fixture having a user interface that is electrically actuated (e.g., an electric push-button, a touch sensor, etc.).

FIG. 17 shows a detailed block diagram of power management system 650 and components thereof according to an exemplary embodiment. Power management system 650 advantageously provides for an efficient use of the electrical energy generated by photovoltaic cells 602. Power manage-



ment system **650** is shown as generally including an energy storage element **660** configured to receive and store electrical energy generated by photovoltaic cells **602**, a detector **670** configured to measure the level (intensity) of ambient light, a switch **680** configured to disconnect energy storage element **660** from control system **50** if the level of ambient light drops below a predetermined value, and a voltage regulator **690** for adjusting the voltage being outputted to control system **50**.

According to an exemplary embodiment, energy storage element **660** includes one or more capacitors suitable for receiving an electric charge from photovoltaic cells **602** and supplying an output voltage to control system **50**. According to a preferred embodiment, energy storage element **660** includes a plurality of capacitors arranged in series to provide the desired capacitance of approximately 3.3 farads (F). According to a particularly preferred embodiment, energy storage element **660** includes a first capacitor, a second capacitor, and a third capacitor. First capacitor, a second capacitor, and a third capacitor are super capacitors having a capacitance of approximately 10 F each or a combined capacitance of approximately 3.3 F. According to an alternative embodiment, other numbers and/or types of capacitors may be used and such capacitors may be arranged in series and/or in parallel.

Energy storage element **660** may be fully charged or partially charged by photovoltaic cells **602**. The rate at which energy storage element **660** is charged depends at least partially on the intensity of the ambient light and the effectiveness (e.g., number, size, efficiency, etc.) of photovoltaic cells **602**. During an initial setup (e.g., anytime energy storage element **660** is fully discharged), the time required to charge energy storage element **660** to a level sufficient to operate the components of control system **50** may be relatively long. The charging time during the initial setup can be reduced by adding a supplemental power source (e.g., a battery, etc.) to charge energy storage element **660**. The supplemental power source provides a “jump-start” for energy storage element **660**, and may significantly reduce the charging time. Preferably, any supplemental power source is removed once energy storage element **660** is sufficiently charged, but alternatively, may remain coupled to the system but electrically disconnected from energy storage element **660**.

A fully charged energy storage element **660** is capable of providing a sufficient amount of electrical energy to power control system **50** for the selective operation of fixtures **14**. According to an exemplary embodiment, energy storage element **660** is capable of providing a sufficient amount electrical energy to allow for more than one activation of fixtures **14** before energy storage element **660** needs to be recharged. According to a preferred embodiment, energy storage element **660** can retain or hold a sufficient amount of electrical energy to provide approximately 70 activations of fixtures **14** before needing to be recharged. As can be appreciated, in a typical application (e.g., an application wherein photovoltaic cells **602** are exposed to ambient light while lavatory system **10** is being used), photovoltaic cells **602** will continue to charge energy storage element **660** as electrical energy is provided for the activation of fixtures **14**.

Control system **50** constitutes a load on energy storage element **660** that when electrically coupled thereto diminishes the electrical energy stored in energy storage element **660**. Disconnecting energy storage element **660** from such a load will help maintain the charge of energy storage element **660**. To determine whether power should be conserved by disconnecting control system **50** from energy storage element **660**, power management system **650** further includes voltage detector **670**. Voltage detector **670** includes an input **672**

electrically coupled to an output from photovoltaic cells **602**. Voltage detector **670** also includes an output **674** electrically coupled to switch **680**.

An output voltage is provided by photovoltaic cells **602**. The magnitude of the output voltage may be based upon the intensity of the ambient light and the efficiency of photovoltaic cells **602**. Voltage detector **670** detects whether photovoltaic cells **602** are being exposed to a level of ambient light sufficient to meet the power demands of control system **50**. According to an exemplary embodiment, a reference voltage value (a baseline value) representative of the sufficient level of ambient light is maintained by voltage detector **670**. Such a reference value may be changed depending on the power requirements of control system **50**.

According to an exemplary embodiment, if photovoltaic cells **602** are not being exposed to a sufficient level of ambient light, the assumption is that lavatory system **10** is not in use (e.g., the lights have been turned down and/or off) and that control system **50** does not need to be powered. In such a situation, control system **50** is disconnected from power management system **650** in an effort to conserve electrical energy. According to a preferred embodiment, voltage detector **670** measures the output voltage of photovoltaic cells **602** (received at input **672**) and compares the output voltage with the reference voltage value. If the output voltage level is below the reference voltage level, voltage detector **670** will send an output signal (at output **674**) to switch **680** indicating that control system **50** should be electrically disconnected from power management system **650**. According to various alternative embodiments, voltage detector **670** may be replaced with any detector suitable for detecting the intensity of the ambient light at photovoltaic cells **602** including, but not limited to, a photodetector configured to monitor the ambient light and send a corresponding signal to switch **680**.

Preferably, energy storage element **660** is capable of holding a charge with minimal leakage when disconnected from the load (control system **50**). Providing energy storage element **660** that is capable of maintaining a charge with minimal leakage, may allow energy storage element **660** to meet the electrical power requirements of control system **50** after photovoltaic cells **602** have not been exposed to ambient light for an extended period of time (e.g., a weekend, etc.). This will eliminate the need to recharge energy storage element **660** (e.g., by a supplemental power source and/or by photovoltaic cells **602**, etc.), or at least reduce the time required to recharge energy storage element **660**, when the ambient light returns and a user seeks to use fixtures **14** of lavatory system **10**. When voltage detector **670** measures a voltage at or above the predetermined baseline voltage, switch **680** reconnects power management system **650** to control system **50**.

Power management system **650** is further shown as including voltage regulator **690** adapted for receiving a first voltage from photovoltaic cells **602** and providing a second voltage to control system **50**. According to an exemplary embodiment, voltage regulator **690** is capable of providing a relatively stable operating voltage to control system **50**. According to an exemplary embodiment, voltage regulator **690** is shown schematically as a dc-to-dc converter. According to a preferred embodiment, the voltage entering the dc-to-dc converter may range between approximately 1.5 volts and 7.5 volts, while the voltage exiting the dc-to-dc converter is approximately 5 volts. As can be appreciated, the input and output voltages may vary in alternative embodiments.

It is important to note that the construction and arrangement of the elements of the lavatory system, including the fixtures, the control system, and/or the photovoltaic system, as shown in the preferred and other exemplary embodiments

19

are illustrative only. Although only a few embodiments of the present inventions have been described in detail in this disclosure, those skilled in the art who review this disclosure will readily appreciate that many modifications are possible (e.g., variations in sizes, dimensions, structures, and proportions of the various elements, values of parameters, mounting arrangements, etc.) without materially departing from the novel teachings and advantages of the subject matter recited herein. For example, the circuit diagrams provided are schematic only, and the values for the individual components (e.g., the ratings for the resistors, capacitors, etc.) may vary according to alternative embodiments. Further, while the description herein may suggest that a pulse generator is used to control pulsing of the transmitter, such control may be accomplished by other means (e.g., software, programming, computations, algorithms, etc.). Even further, while the inventions described herein are described with reference to use washing stations, the inventions may be used with any of a variety of different applications wherein a control system of the type disclosed herein would be beneficial. Further, the position of elements may be reversed or otherwise varied (e.g., the circuit diagram may be modified or may be incorporated in other circuits), and the nature or number of discrete elements or positions may be altered or varied. It should further be noted that the scope of the inventions include all software conventionally known or suitable for use with proximity sensors. For example, the control system may be programmed with failure modes for closing the valve if left open for an extended period. Further, the control system may be programmed to provide extended sleep periods when the fixture has not been used for a set time. The control system may also be programmed to require two positive reads before the valve is opened.

The order or sequence of any process or method steps may be varied or re-sequenced according to alternative embodiments. Any means-plus-function clause is intended to cover the structures described herein as performing the recited function and not only structural equivalents but also equivalent structures. Other substitutions, modifications, changes and omissions may be made in the design, operating configuration and arrangement of the preferred and other exemplary embodiments without departing from the spirit of the inventions as expressed in the appended claims.

What is claimed is:

1. A lavatory comprising:

at least one wash station;

at least one electrically operated fixture associated with the wash station;

a detection system comprising a sensor for monitoring a sensing region for the presence of a user and configured to generate and transmit a control signal;

a control system coupled to the detection system and configured to receive the control signal from the detection system and control a flow of a fluid through the at least one electrically operated fixture based upon the control signal;

a power source selectively coupled to the detection system; and

a power management system coupled to the power source to control the power provided to the detection system, the power management system comprising:

a detector configured to monitor a level of ambient light near the lavatory by monitoring an output voltage of the power source, the power source comprising at least one photovoltaic cell configured to convert the ambient light into output power; and

20

a switching device configured to electrically disconnect the power source from the detection system in response to the level of ambient light dropping below a predetermined ambient light level as indicated when the output voltage of the power source drops below a predetermined level.

2. The lavatory of claim 1, wherein the sensor is an infrared sensor.

3. The lavatory of claim 1, wherein the at least one photovoltaic cell comprises an array of photovoltaic cells.

4. The lavatory of claim 1, further comprising an energy storage element electrically coupled between the at least one photovoltaic cell and the switching device for storing the output voltage generated by the photovoltaic cell.

5. The lavatory of claim 4, wherein the energy storage element is a capacitor.

6. The lavatory of claim 1, wherein the power source is further selectively coupled to the control system, wherein the switching device is further configured to electrically disconnect the power source from the control system when the output voltage of the power source drops below the predetermined level.

7. A control system for use with a lavatory system having at least one wash station and at least one electrically operated fixture, the control system comprising:

a detection system configured to monitor a sensing region for the presence of a user and generate a transmit a control signal;

a fixture actuation system coupled to the detection system and configured to receive the control signal from the detection system and control a flow of a fluid through the fixture based upon the control signal;

a power source selectively coupled to the detection system; and

a power management system coupled to the power source to control the power provided to the detection system, the power management system comprising:

a detector configured to monitor a level of ambient light near the lavatory by monitoring an output voltage of the power source, the power source comprising at least one photovoltaic cell configured to convert the ambient light into output power; and

a switching device configured to electrically disconnect the power source from the detection system in response to the level of ambient light dropping below a predetermined ambient light level as indicated when the output voltage of the power source drops below a predetermined level.

8. The control system of claim 7, wherein the detection system comprises a control circuit that is operable during a first period during which the sensing region is monitored for the presence of the user followed by a second period during which the power consumption of the control circuit is reduced.

9. The control system of claim 8, wherein the detection system comprises a sensor coupled to the control circuit, the sensor comprises a transmitter and a receiver for monitoring the sensing region.

10. The control system of claim 7, wherein the at least one photovoltaic cell comprises an array of photovoltaic cells.

11. The control system of claim 7, further comprising an energy storage element electrically coupled between the at least one photovoltaic cell and the switching device for storing the output voltage generated by the photovoltaic cell.

12. The control system of claim 11, wherein the energy storage element is a capacitor.

## 21

13. A power supply system for a lavatory system having a control system for operating a fixture, the power supply system comprising:

a power source configured to be electrically coupled to the control system and to provide an output voltage; and

a power management system coupled to the power source, the power management system comprising:

a detector configured to monitor a level of ambient light near the lavatory by monitoring the output voltage of the power source, the power source comprising at least one photovoltaic cell configured to convert the ambient light into output power; and

a switch configured to electrically disconnect the power source from a detection system in response to the level of ambient light dropping below a predetermined ambient light level as indicated when the output voltage of the power source drops below a predetermined level, wherein the detection system comprises a sen-

## 22

sor for monitoring a sensing region for the presence of a user and is configured to transmit a control signal to the control system, wherein the control signal is configured to cause the control system to control a flow of a fluid through the fixture based on the control signal.

14. The power supply system of claim 13, wherein the at least one photovoltaic cell comprises an array of photovoltaic cells.

15. The power supply system of claim 13, further comprising an energy storage element electrically coupled between the at least one photovoltaic cell and the switch for storing the output voltage generated by the photovoltaic cell.

16. The power supply system of claim 15, wherein the energy storage element is a capacitor.

17. The power supply system of claim 13, further comprising a regulator for adjusting the output voltage of the power source before being received by the control system.

\* \* \* \* \*

UNITED STATES PATENT AND TRADEMARK OFFICE  
**CERTIFICATE OF CORRECTION**

PATENT NO. : 8,984,679 B2  
APPLICATION NO. : 13/367945  
DATED : March 24, 2015  
INVENTOR(S) : Graeme S. Bayley et al.

Page 1 of 1

It is certified that error appears in the above-identified patent and that said Letters Patent is hereby corrected as shown below:

In the Claims

**Claim 7:**

Column 20, line 28, replace --a-- with “and” after “...and generate”

Signed and Sealed this  
Fifteenth Day of September, 2015



Michelle K. Lee  
*Director of the United States Patent and Trademark Office*