



US008979715B2

(12) **United States Patent**  
**Hamilton**

(10) **Patent No.:** **US 8,979,715 B2**  
(45) **Date of Patent:** **Mar. 17, 2015**

(54) **PORTABLE AND ATTACHABLE BICYCLE TRAINER**

(76) Inventor: **Brian H. Hamilton**, Charlotte, NC (US)

(\*) Notice: Subject to any disclaimer, the term of this patent is extended or adjusted under 35 U.S.C. 154(b) by 802 days.

(21) Appl. No.: **13/159,816**

(22) Filed: **Jun. 14, 2011**

(65) **Prior Publication Data**

US 2011/0275488 A1 Nov. 10, 2011

**Related U.S. Application Data**

(63) Continuation-in-part of application No. 12/206,696, filed on Sep. 8, 2008, now Pat. No. 7,766,798, and a continuation-in-part of application No. 12/270,223, filed on Nov. 13, 2008, now Pat. No. 7,955,228, and a continuation-in-part of application No. 12/725,654, filed on Mar. 17, 2010, now abandoned.

(60) Provisional application No. 61/354,676, filed on Jun. 14, 2010.

(51) **Int. Cl.**

**A63B 69/16** (2006.01)  
**A63B 21/015** (2006.01)  
**A63B 24/00** (2006.01)  
**A63B 21/00** (2006.01)  
**A63B 21/008** (2006.01)

(52) **U.S. Cl.**

CPC ..... **A63B 69/16** (2013.01); **A63B 24/0087** (2013.01); **A63B 21/00069** (2013.01); **A63B 21/0081** (2013.01); **A63B 21/015** (2013.01); **A63B 2024/009** (2013.01); **A63B 2069/163** (2013.01); **A63B 2069/165** (2013.01); **A63B 2069/166** (2013.01); **A63B 2220/78** (2013.01)  
USPC ..... **482/61**; **482/63**; **482/65**

(58) **Field of Classification Search**

USPC ..... 482/51, 57-65  
See application file for complete search history.

(56) **References Cited**

U.S. PATENT DOCUMENTS

627,483 A	6/1899	Comly	
1,661,679 A	3/1928	Privett	
2,041,134 A *	5/1936	Kassler	74/13
2,462,018 A	2/1949	Wood	
2,972,478 A	2/1961	Vincent	
4,423,863 A	1/1984	Figuroa	
4,506,676 A	3/1985	Duska	

(Continued)

OTHER PUBLICATIONS

Commonly-owned U.S. Appl. No. 13/454,575, filed Apr. 24, 2012, entitled "Bicycle Trainer With Variable Resistance to Pedaling".

*Primary Examiner* — Stephen Crow

(74) *Attorney, Agent, or Firm* — Additon, Higgins & Pendleton, P.A.

(57) **ABSTRACT**

The invention encompasses a removable attachment for installing on a bicycle with the goal of altering the resistance to either front tire or back tire revolution. In this way, the bicycle includes enhanced physical training capabilities allowing the rider to use a bicycle on a standard trainer frame or as a regular bicycle for riding in the usual manner. In one embodiment, the attachment includes a resistance support connected to a bicycle and supporting a resistance device that engages a bicycle wheel or bicycle tire for altering the resistance to tire revolution. In this exemplary embodiment, the apparatus includes a resistance support attached to the bicycle proximate a bicycle tire along with a resistance device removably attached to the resistance support. In one embodiment, the resistance device defines a slot, and the resistance support projects through the slot to position the resistance device against the bicycle wheel or the bicycle tire.

**7 Claims, 51 Drawing Sheets**

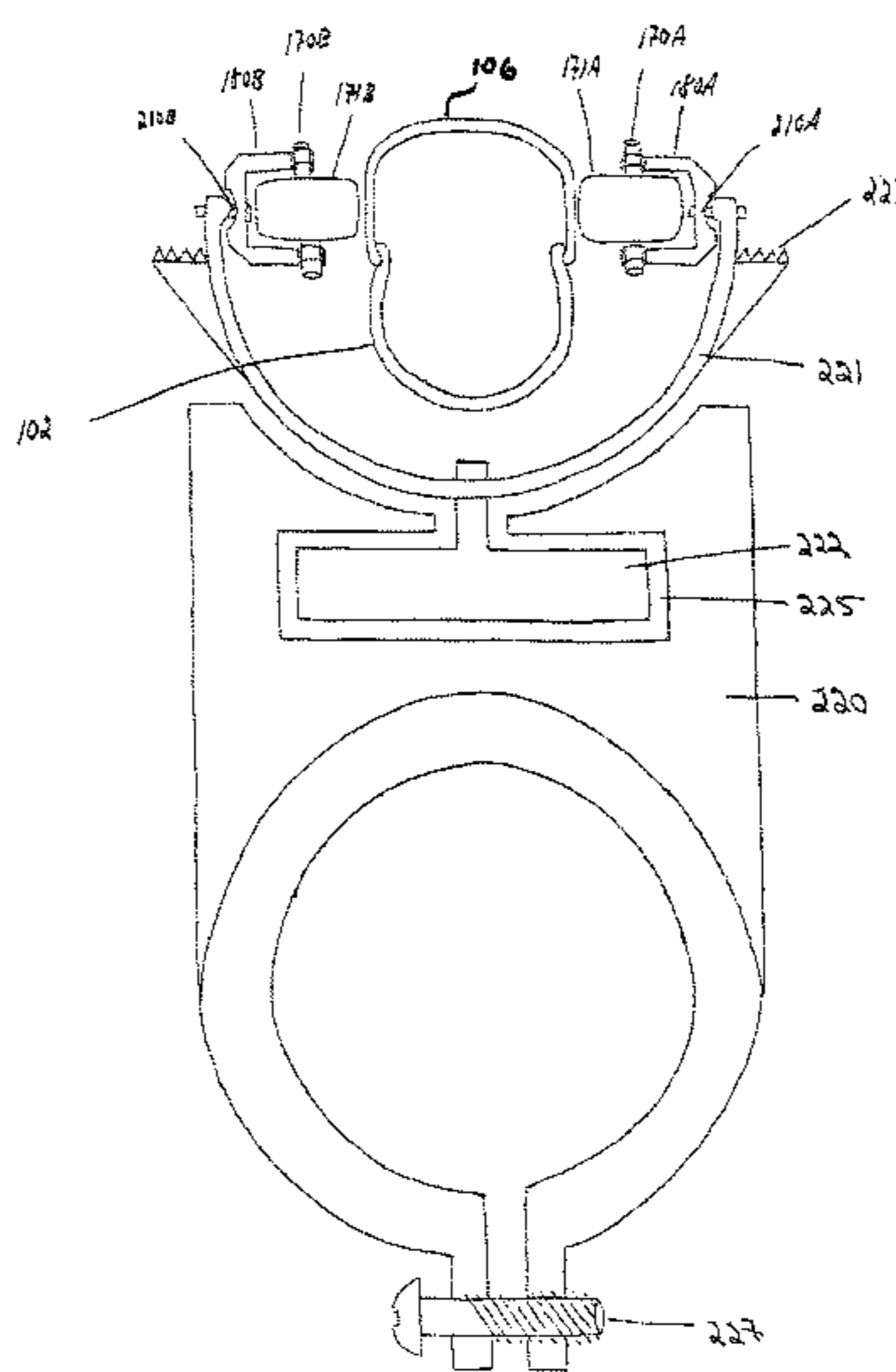

(56)

References Cited

U.S. PATENT DOCUMENTS

4,641,560	A *	2/1987	Kolberg .....	83/788	6,910,992	B2	6/2005	Arguilez
4,645,199	A	2/1987	Bloemendaal		6,945,916	B2	9/2005	Schroeder
4,752,066	A	6/1988	Housayama		6,945,917	B1	9/2005	Baatz
4,813,062	A	3/1989	Gilpatrick		6,964,633	B2	11/2005	Kolda et al.
4,955,600	A	9/1990	Hoffenberg et al.		7,011,607	B2	3/2006	Kolda et al.
4,958,832	A	9/1990	Kim		7,083,551	B1	8/2006	Lassanske et al.
5,031,901	A	7/1991	Saarinen		7,226,395	B2	6/2007	Wu et al.
5,052,705	A *	10/1991	Ringle .....	280/212	7,303,510	B2	12/2007	Gebhardt
5,110,118	A	5/1992	Winey		7,311,640	B2	12/2007	Baatz
5,193,106	A	3/1993	DeSena		7,314,434	B2	1/2008	Chen
5,236,069	A	8/1993	Peng		7,413,531	B2	8/2008	McLaughlin
RE34,479	E	12/1993	Minoura		7,470,220	B2	12/2008	Hernandez
5,382,208	A	1/1995	Hu		D593,625	S	6/2009	Pedrini
5,545,982	A *	8/1996	Vlakancic .....	324/174	7,628,739	B2	12/2009	Gearon
5,656,001	A	8/1997	Baatz		7,766,798	B2	8/2010	Hamilton
5,916,067	A *	6/1999	Morasse .....	482/61	7,955,228	B2	6/2011	Hamilton
5,944,637	A	8/1999	Stickler et al.		8,162,806	B2	4/2012	Hamilton
6,042,517	A	3/2000	Gunther et al.		2002/0055422	A1	5/2002	Airmet et al.
6,116,415	A	9/2000	Rastelli		2002/0193207	A1	12/2002	Wang
6,450,922	B1	9/2002	Henderson et al.		2003/0073546	A1	4/2003	Lassanske et al.
6,508,745	B1	1/2003	Schenk et al.		2004/0053751	A1	3/2004	Pizolato
6,568,446	B1	5/2003	Schulte		2005/0008992	A1	1/2005	Westergaard et al.
6,712,737	B1	3/2004	Nusbaum		2005/0209064	A1	9/2005	Peterson et al.
6,749,543	B2	6/2004	McLaughlin		2006/0229163	A1	10/2006	Waters
6,857,992	B1	2/2005	Kolda et al.		2007/0004565	A1	1/2007	Gebhardt
					2010/0200136	A1	8/2010	Hamilton
					2010/0298103	A1	11/2010	Hamilton
					2011/0212812	A1	9/2011	Hamilton

\* cited by examiner

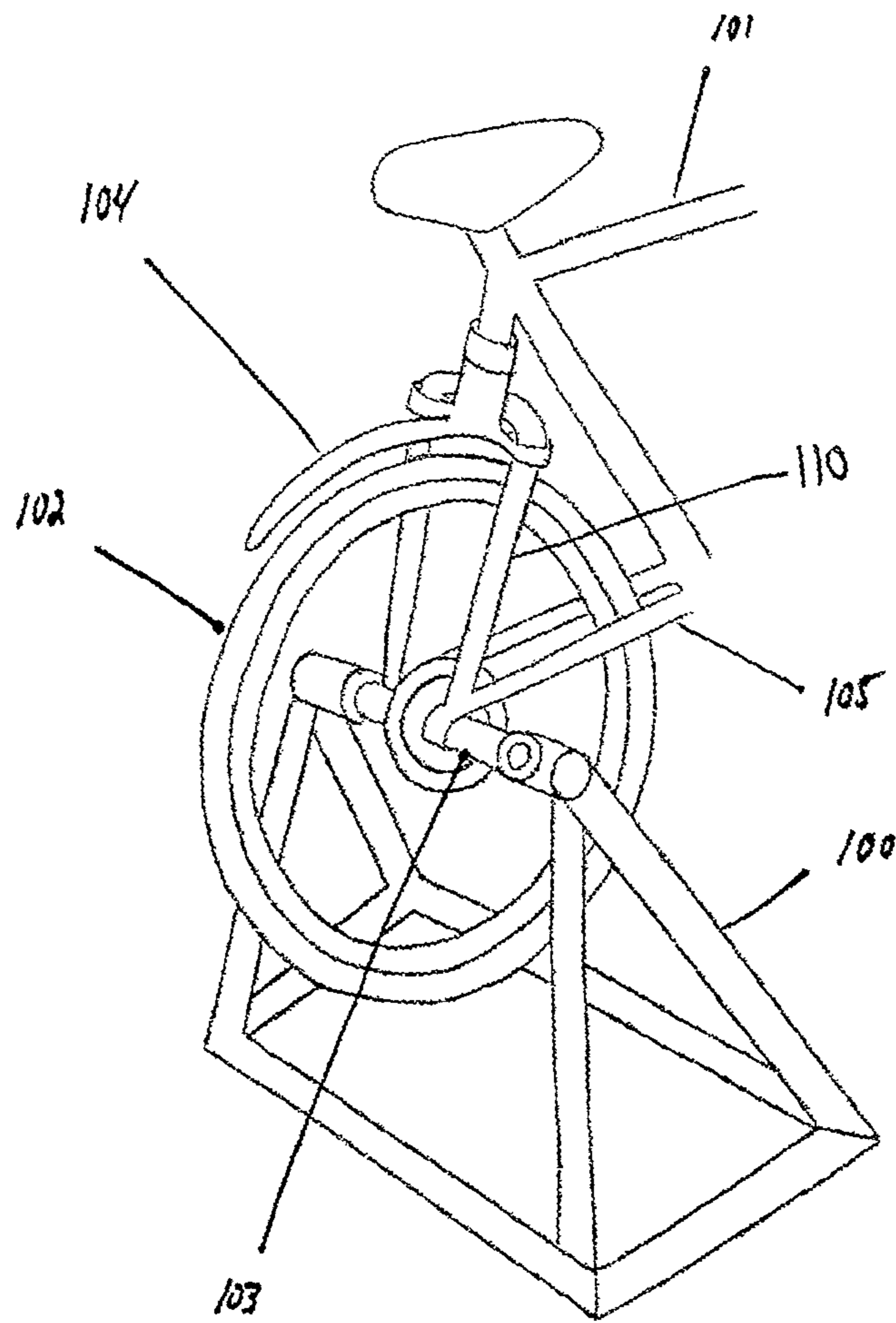

Figure 1

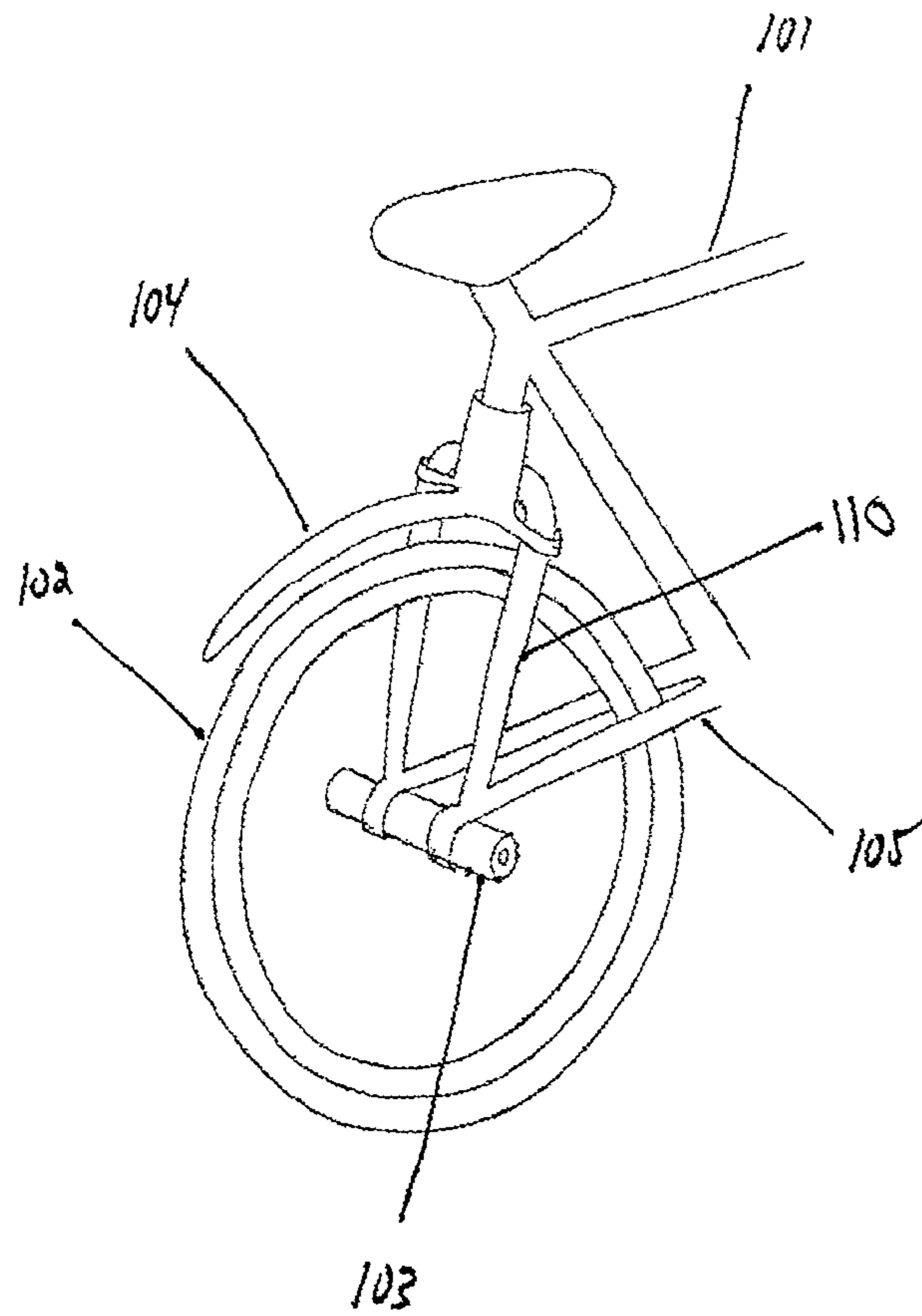

Figure 2

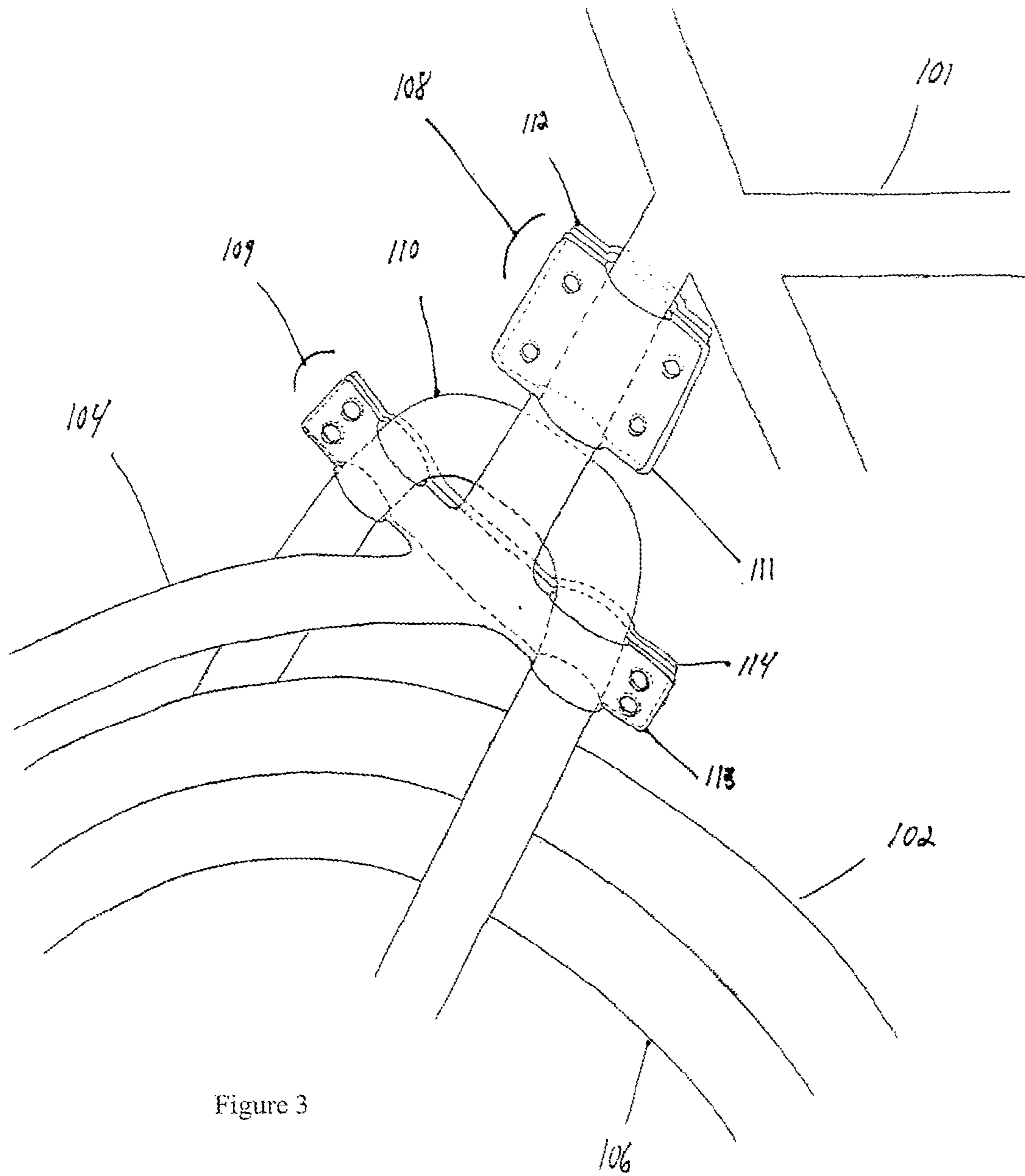

Figure 3

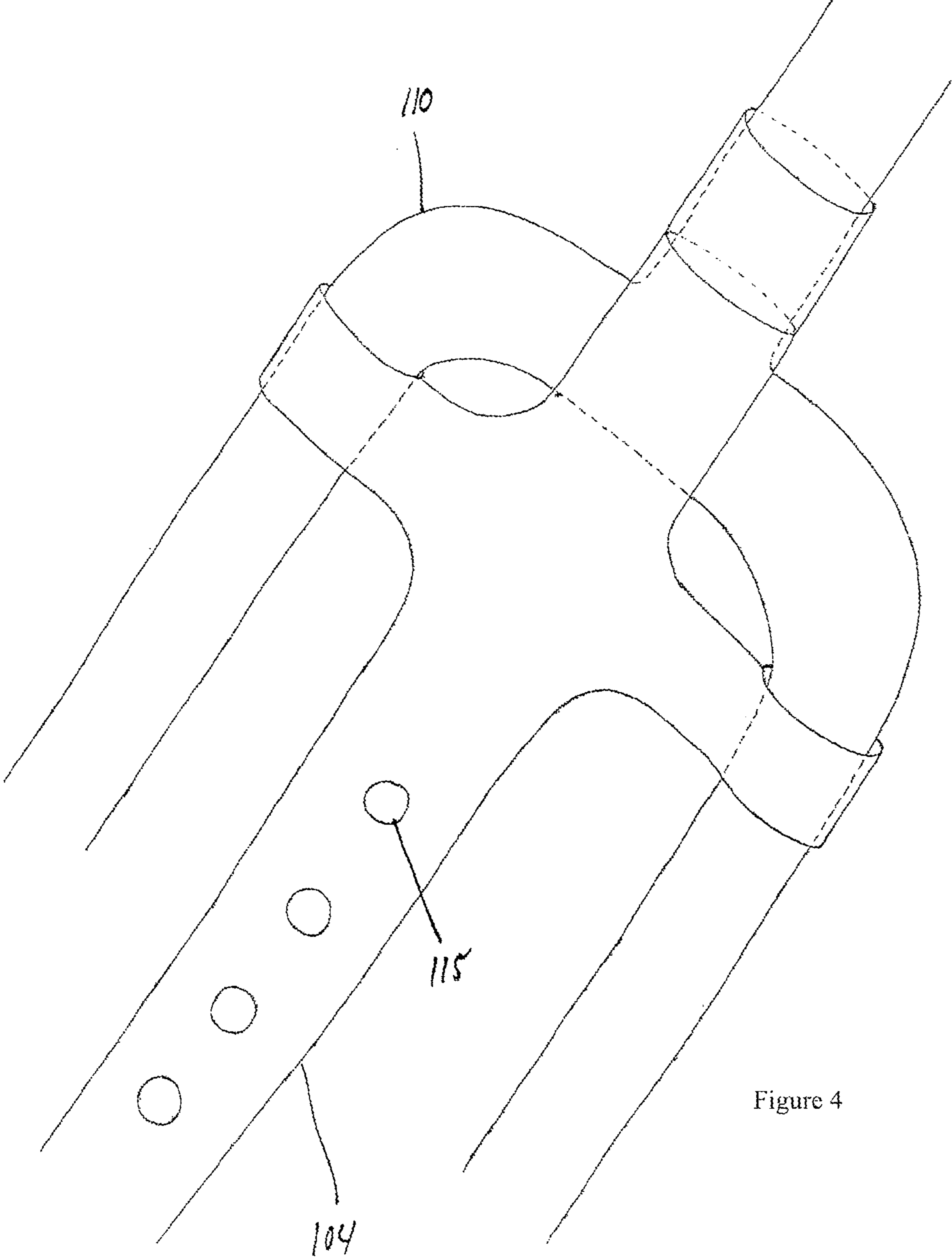
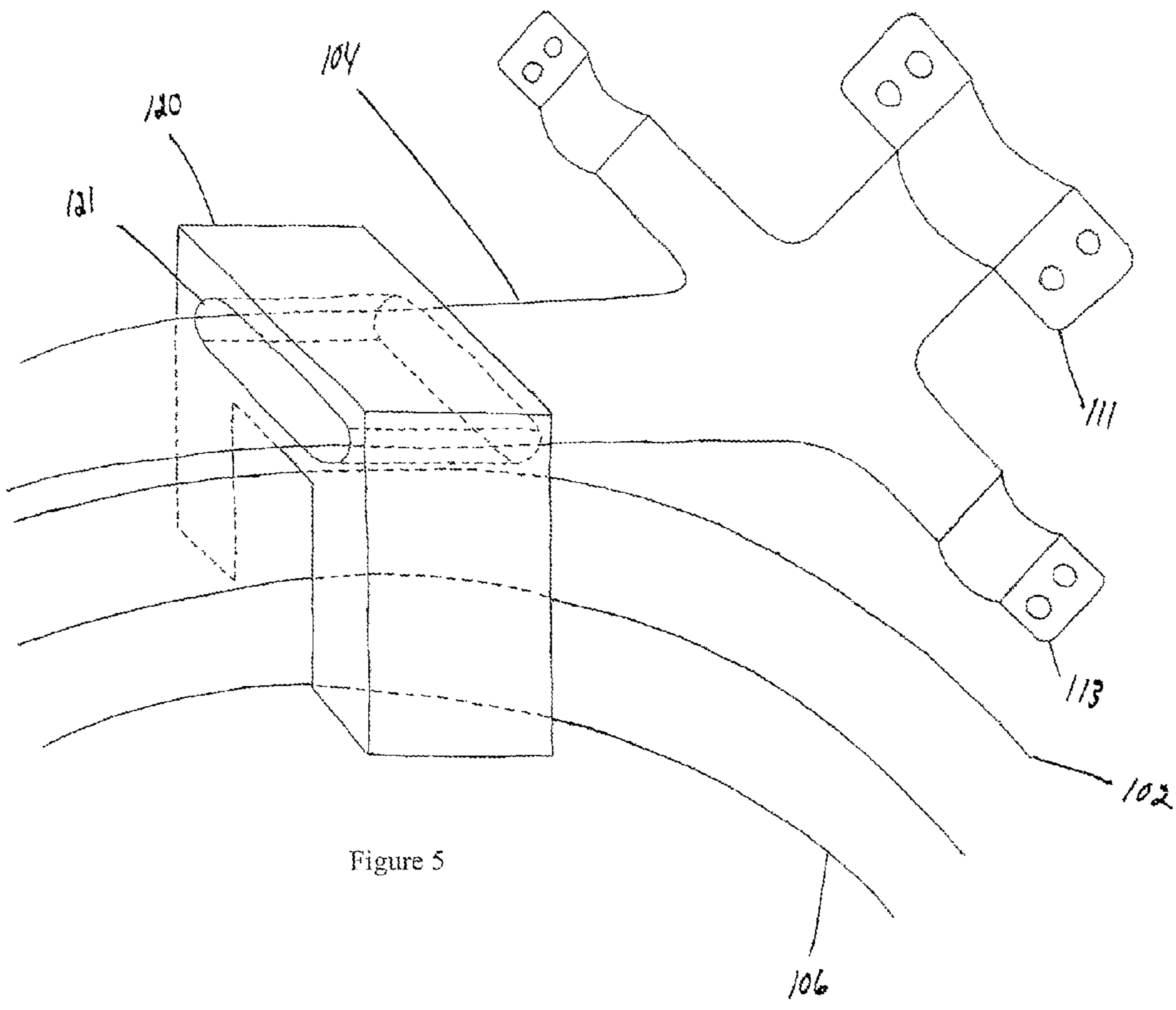

Figure 4



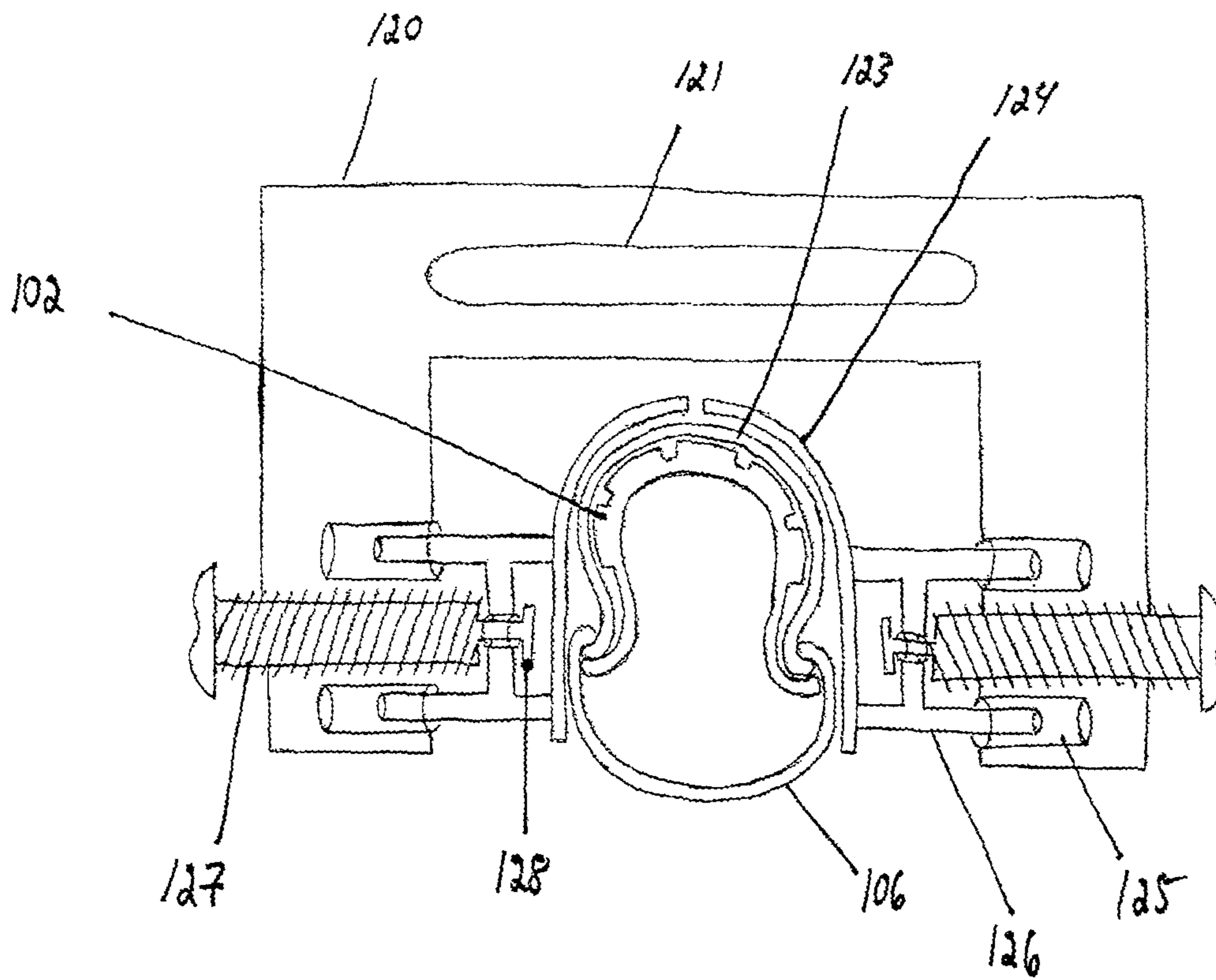

Figure 6



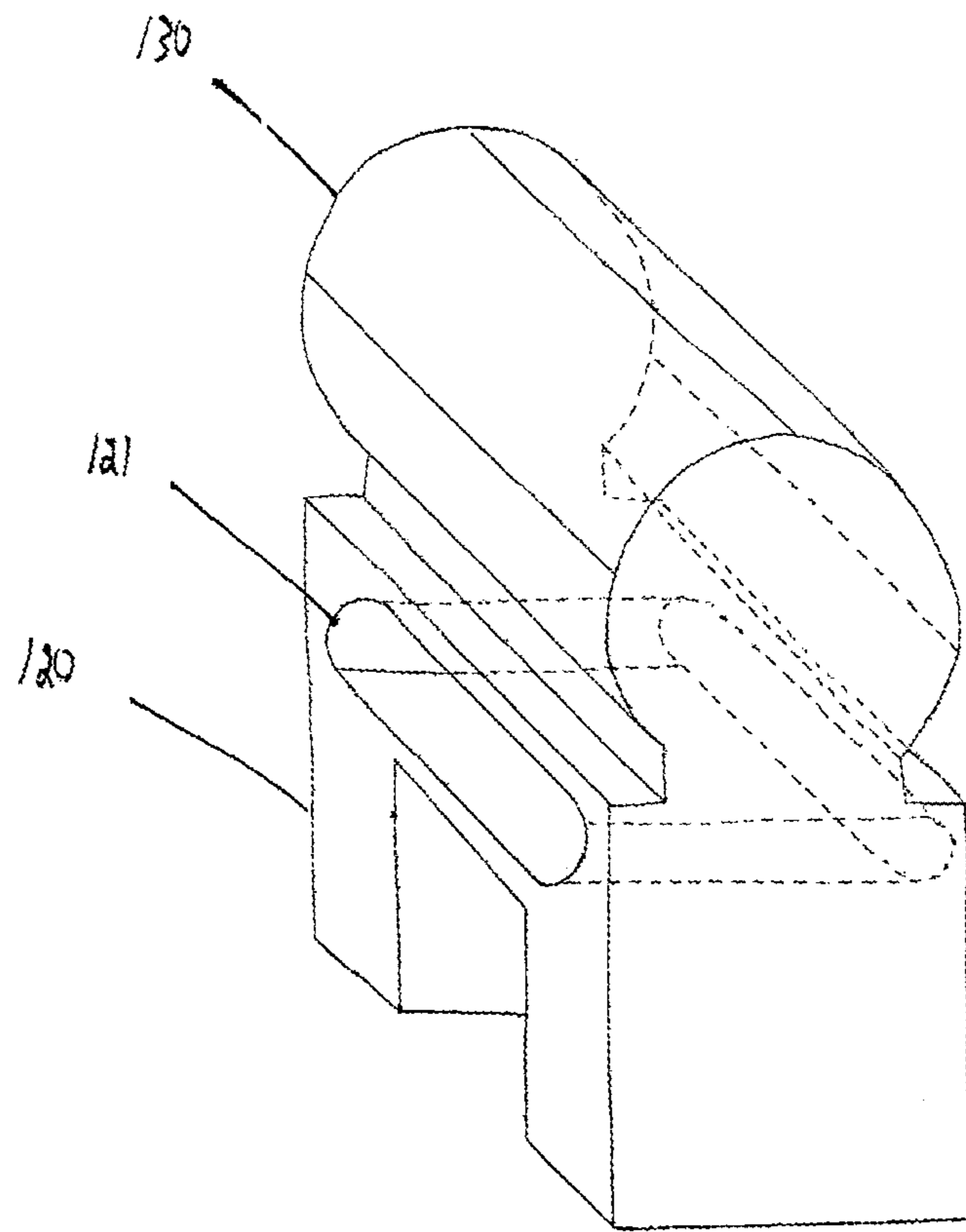

Figure 7

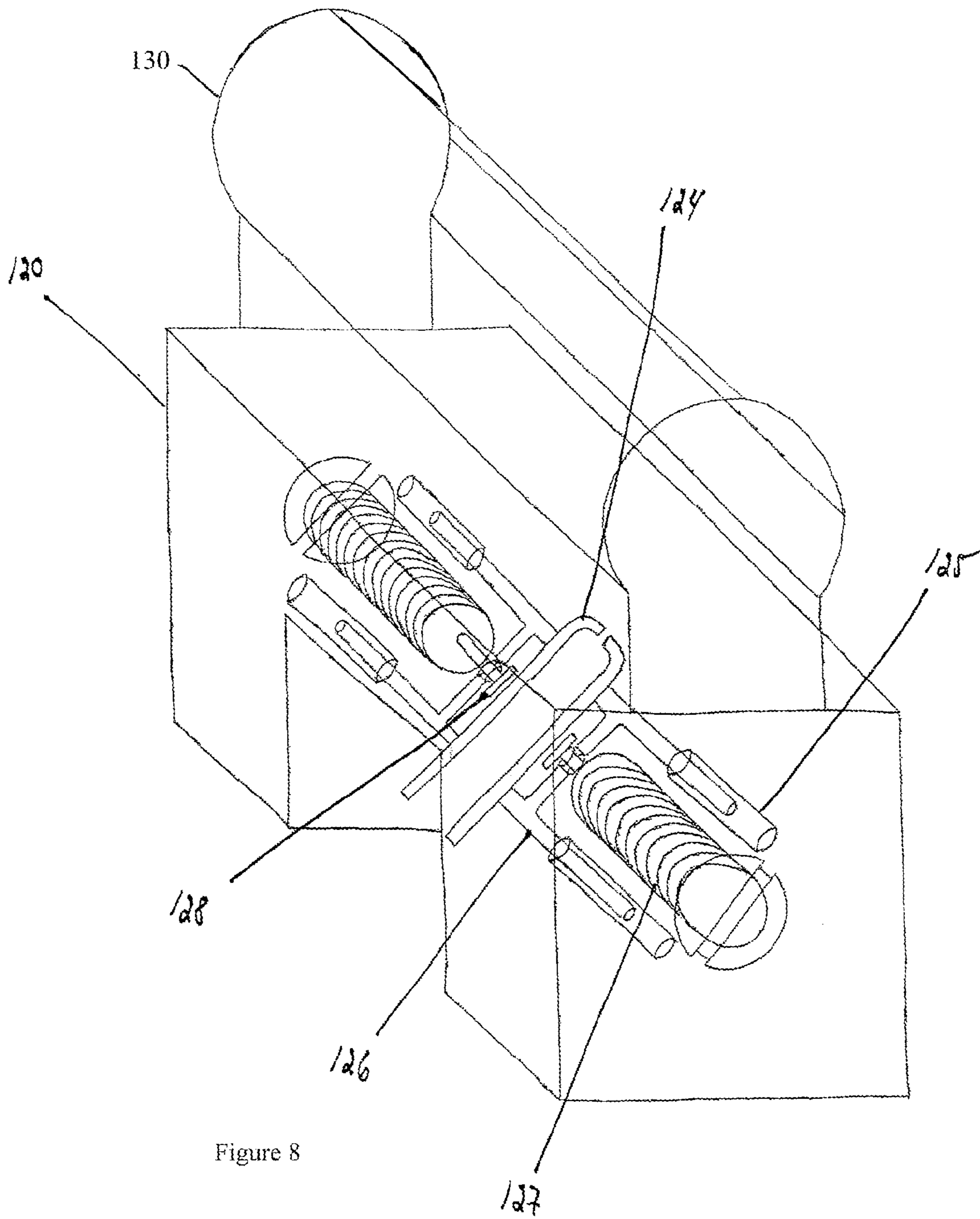

Figure 8

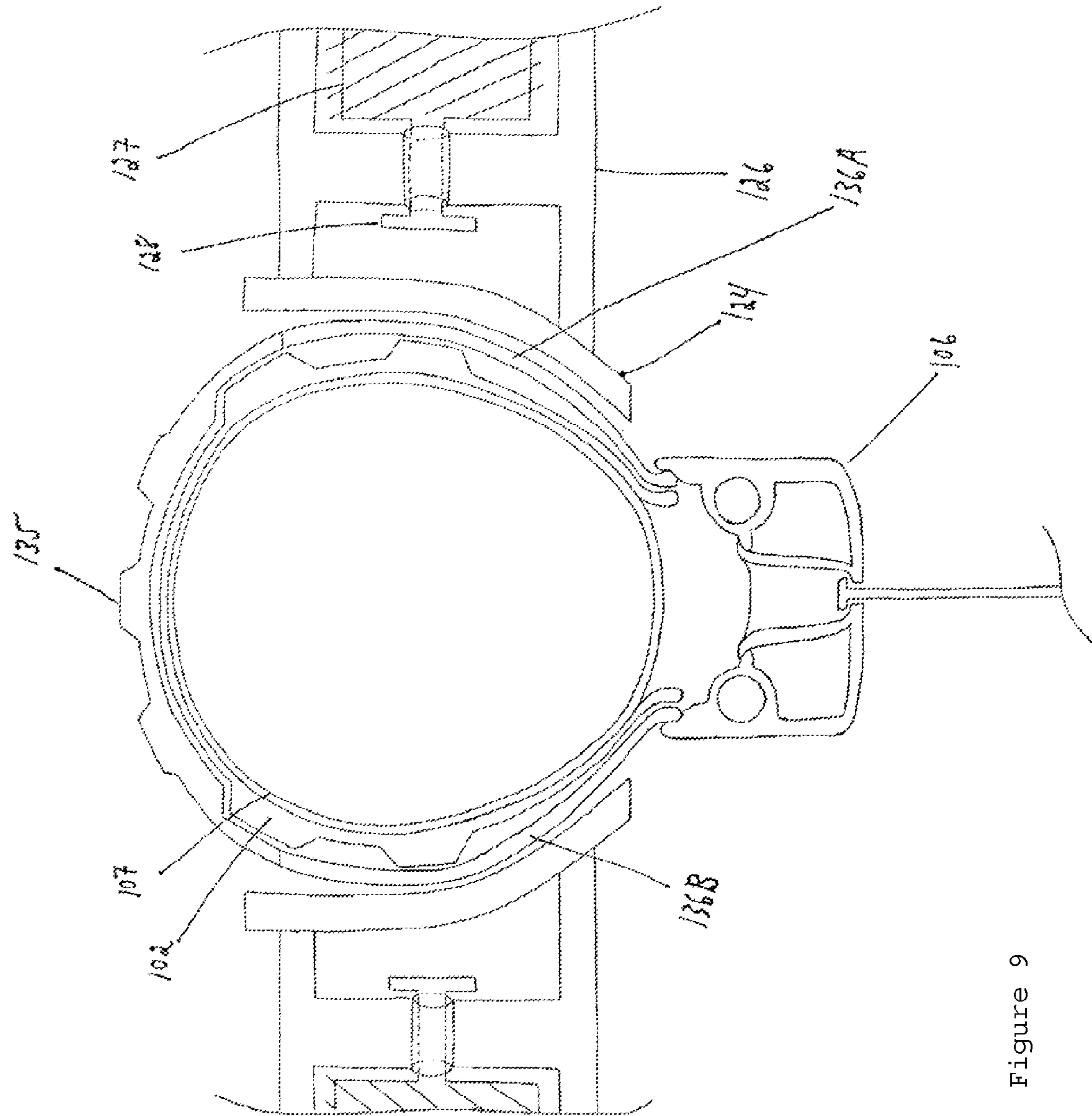

Figure 9

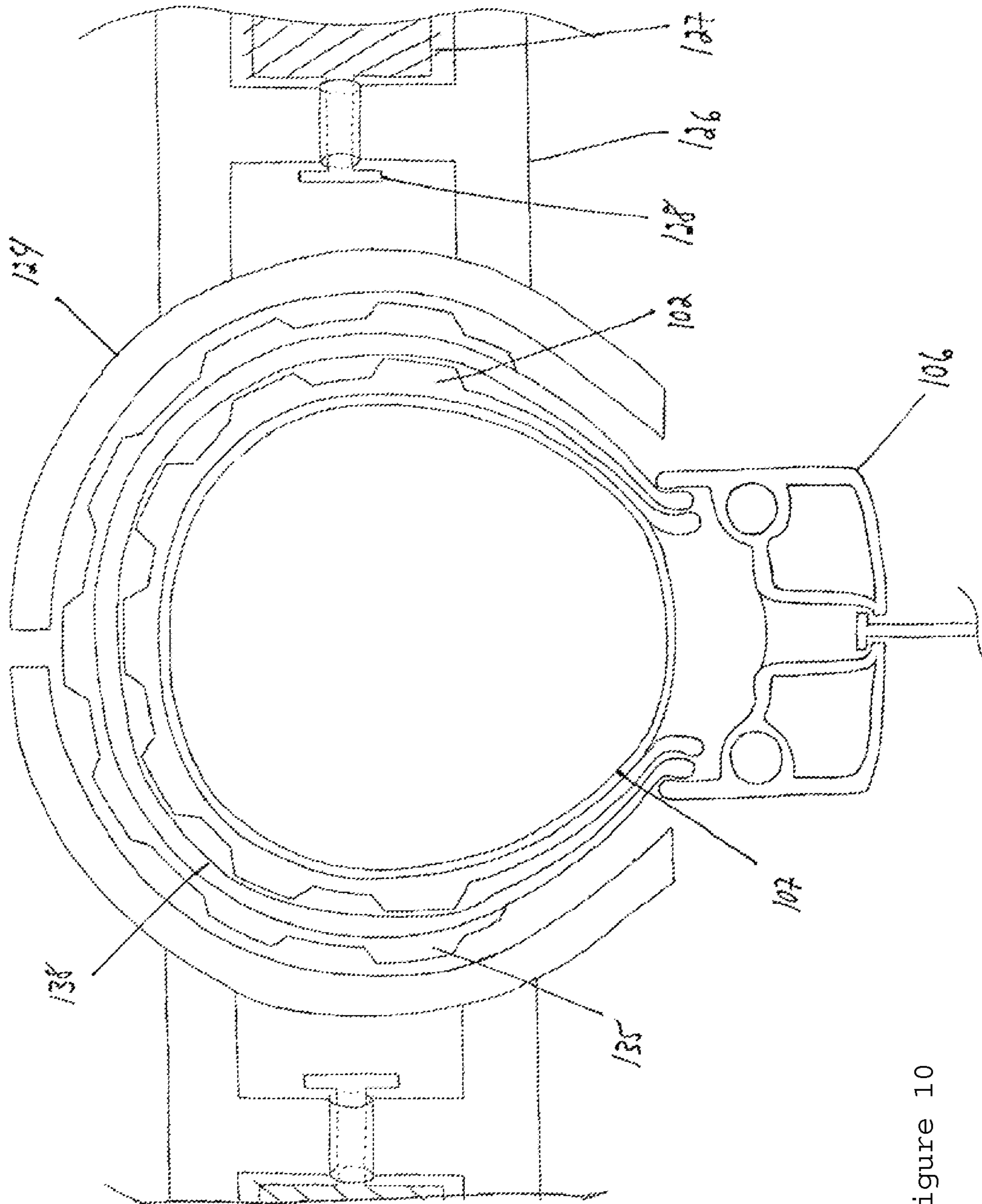

Figure 10

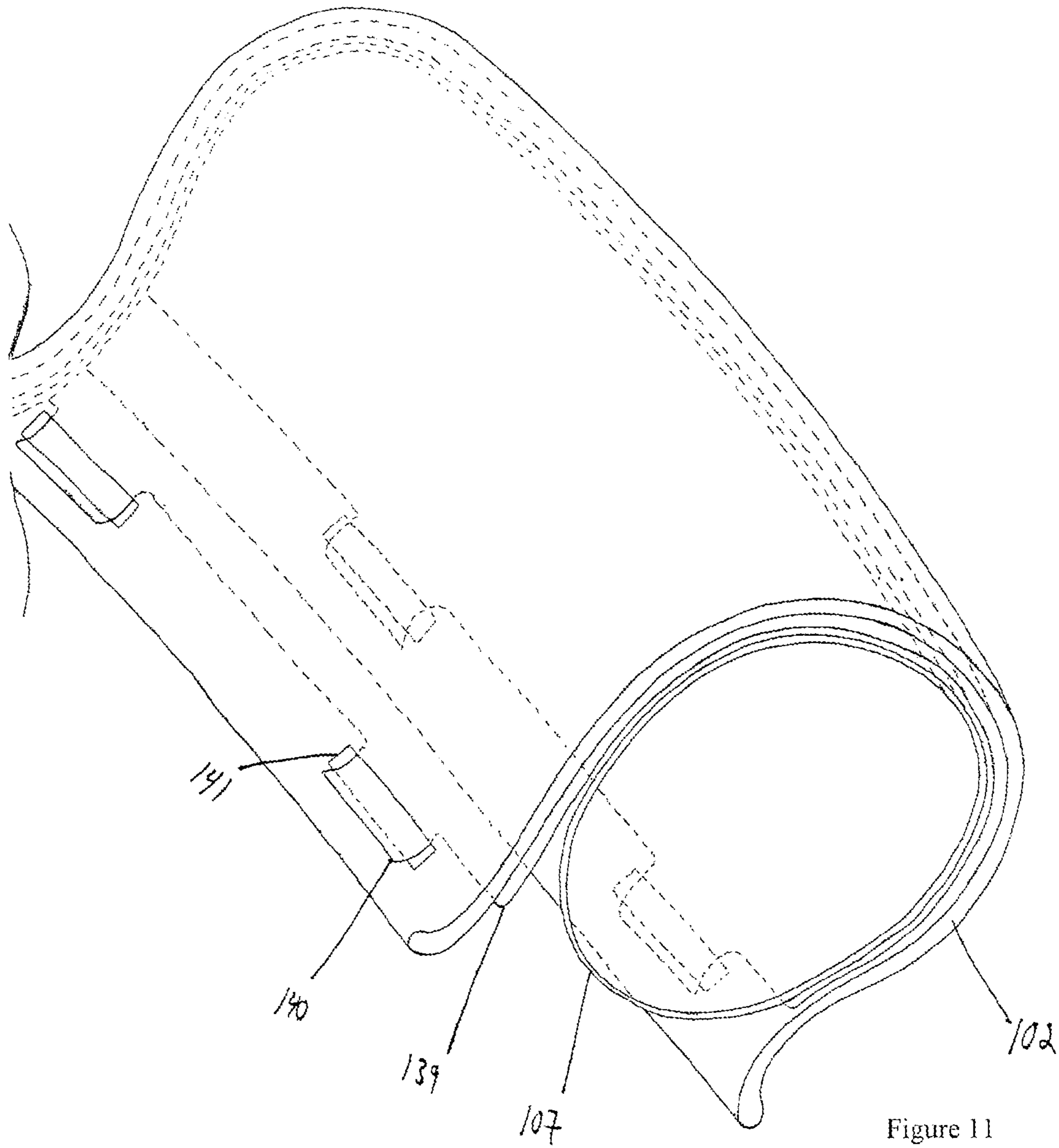

Figure 11

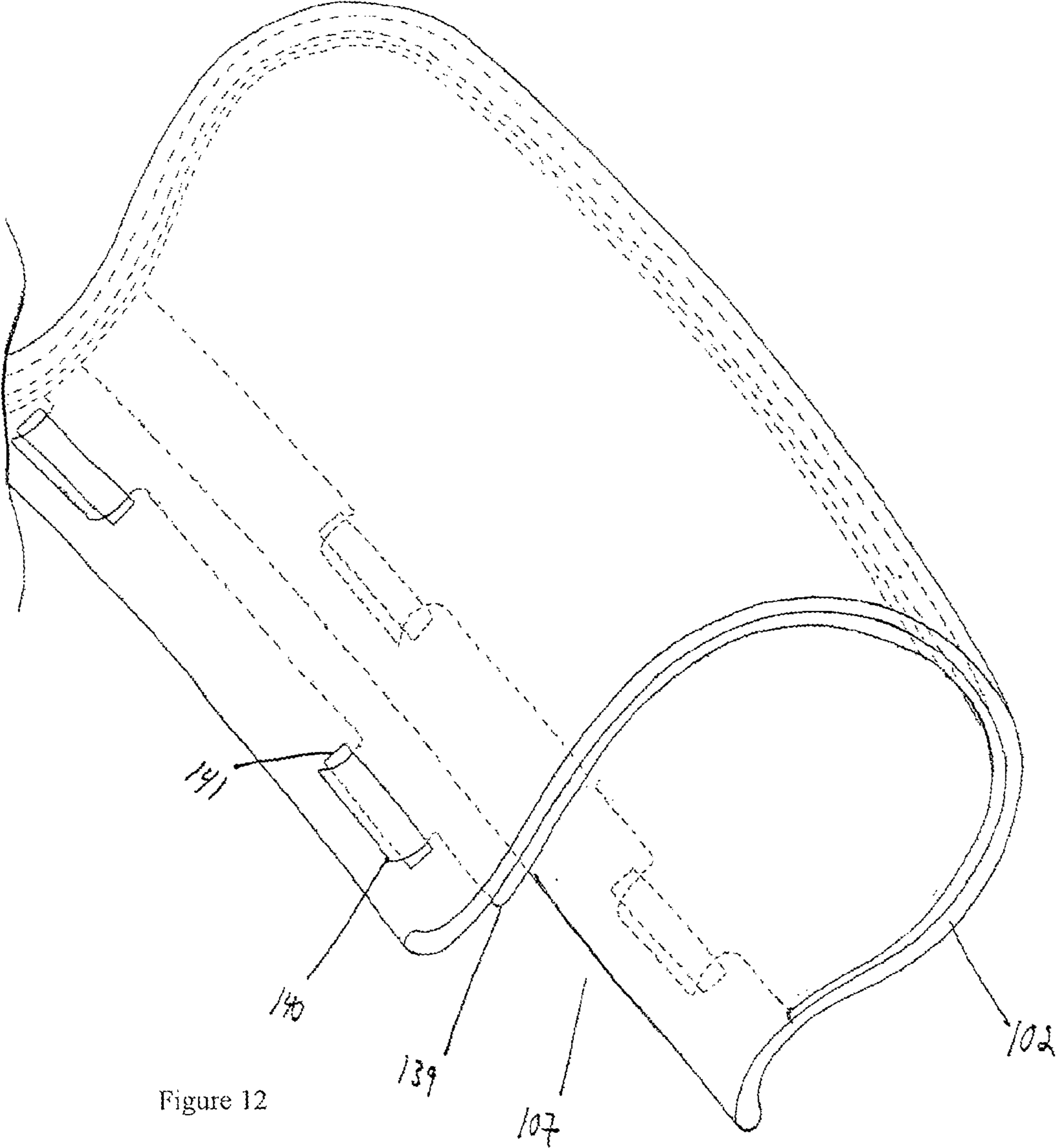

Figure 12

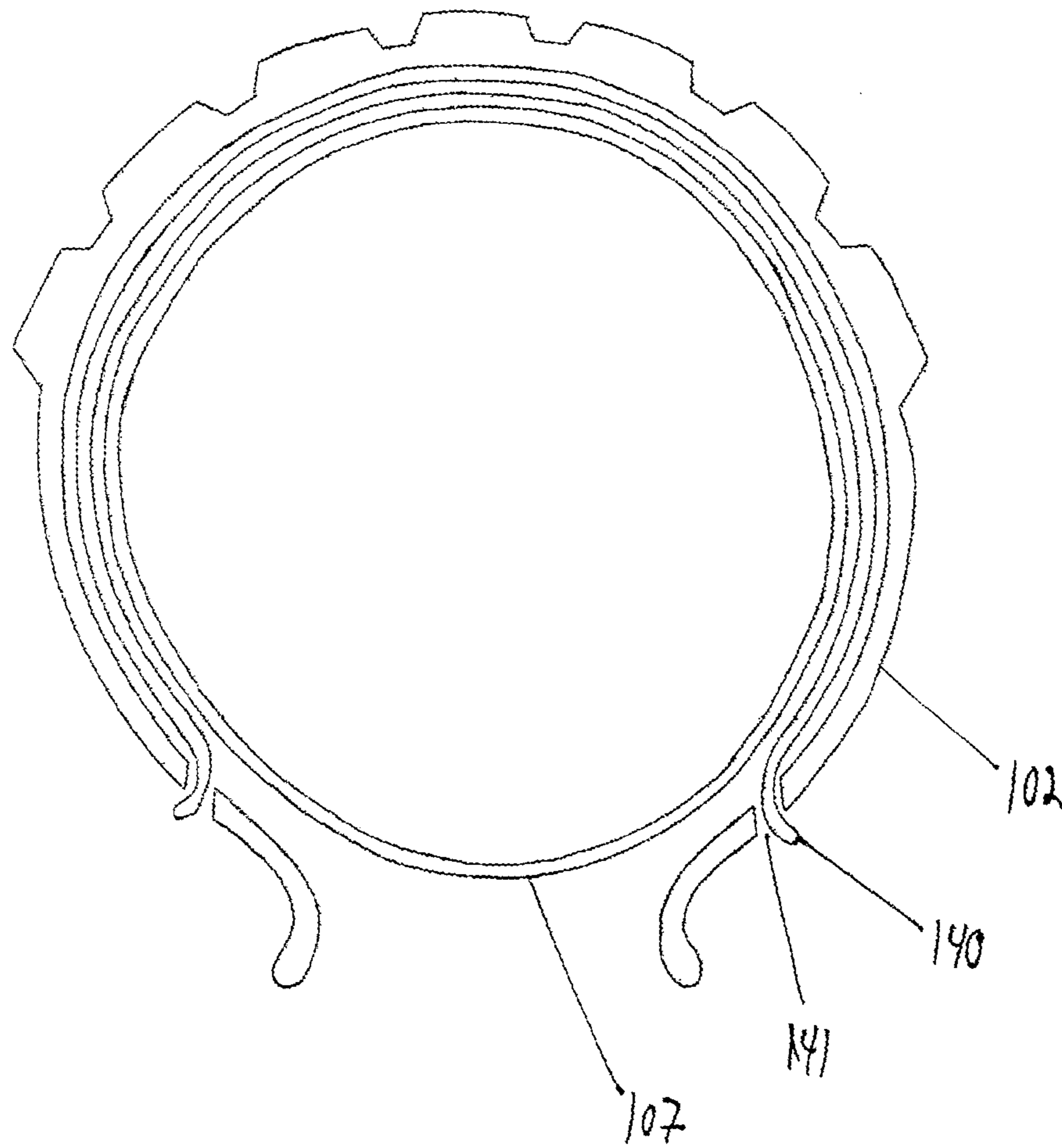

Figure 13

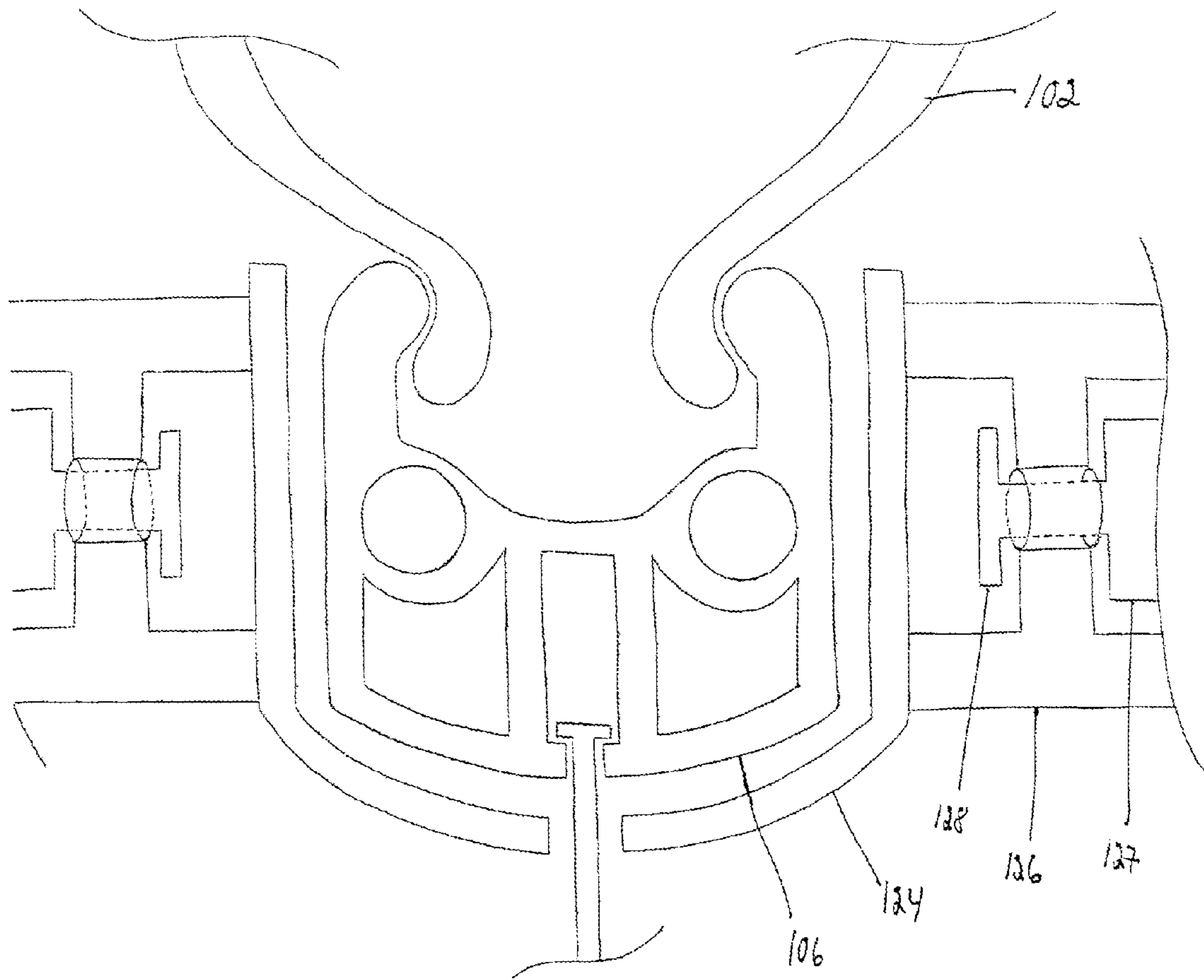

Figure 14



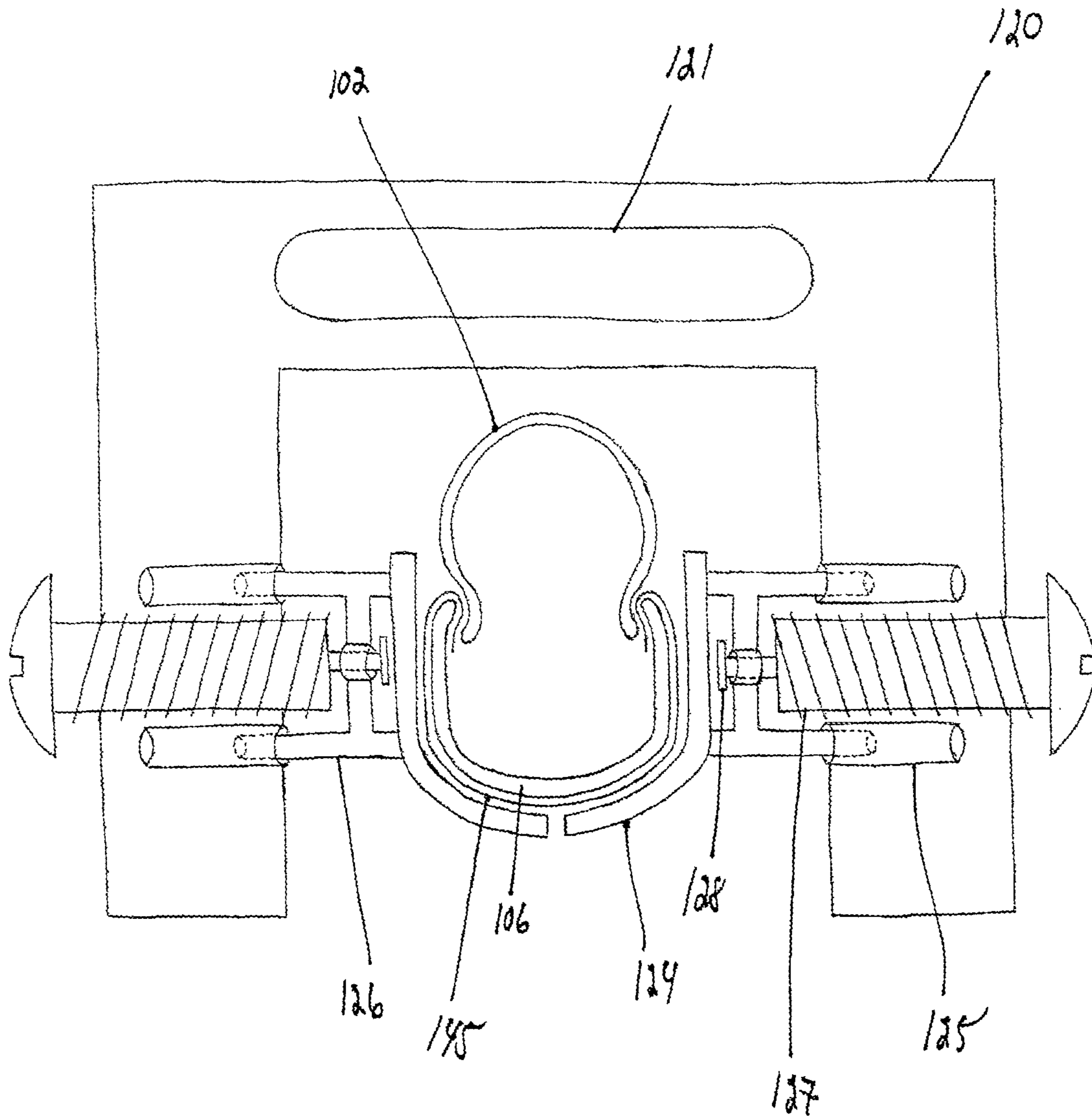

Figure 15

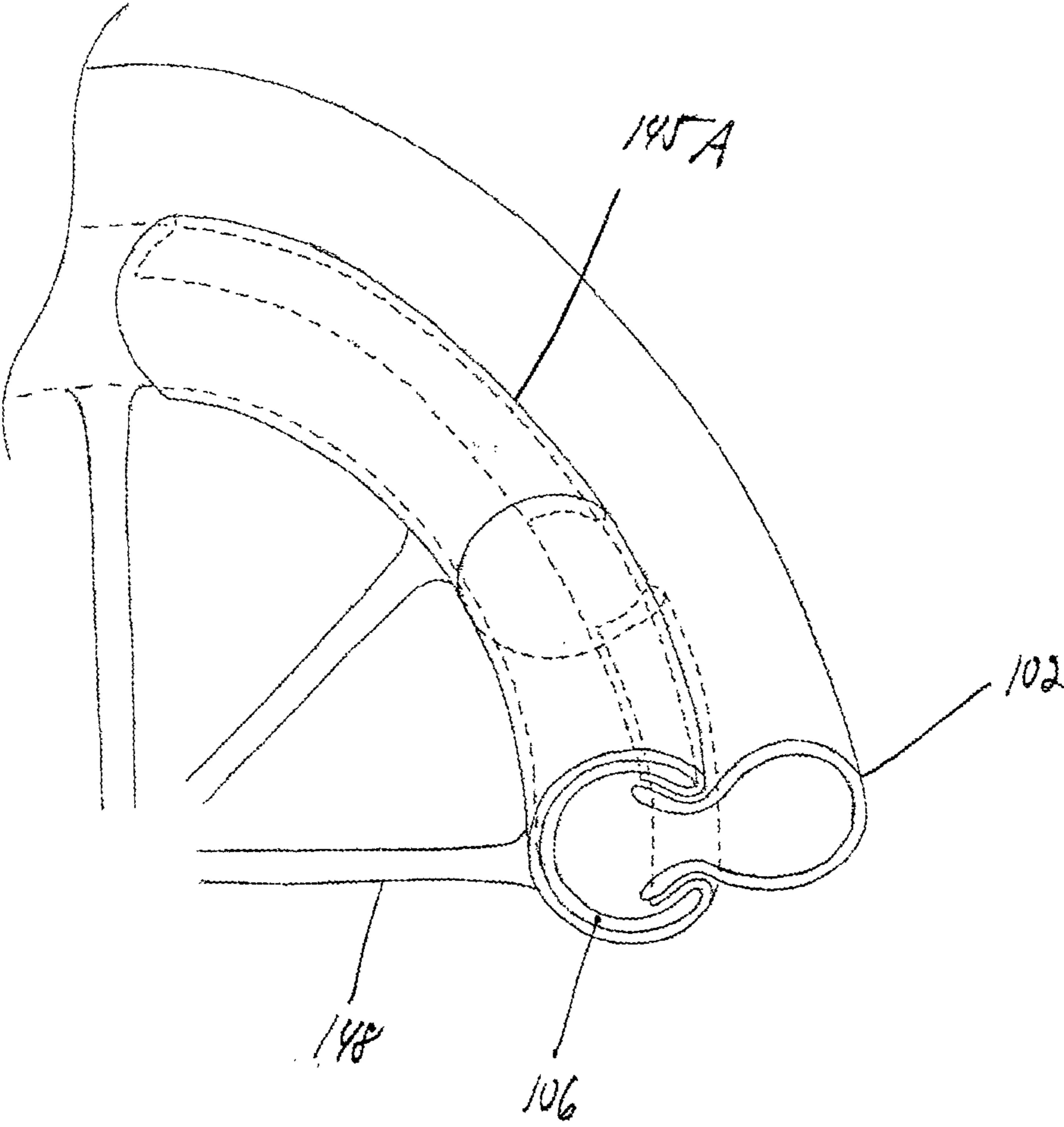

Figure 16

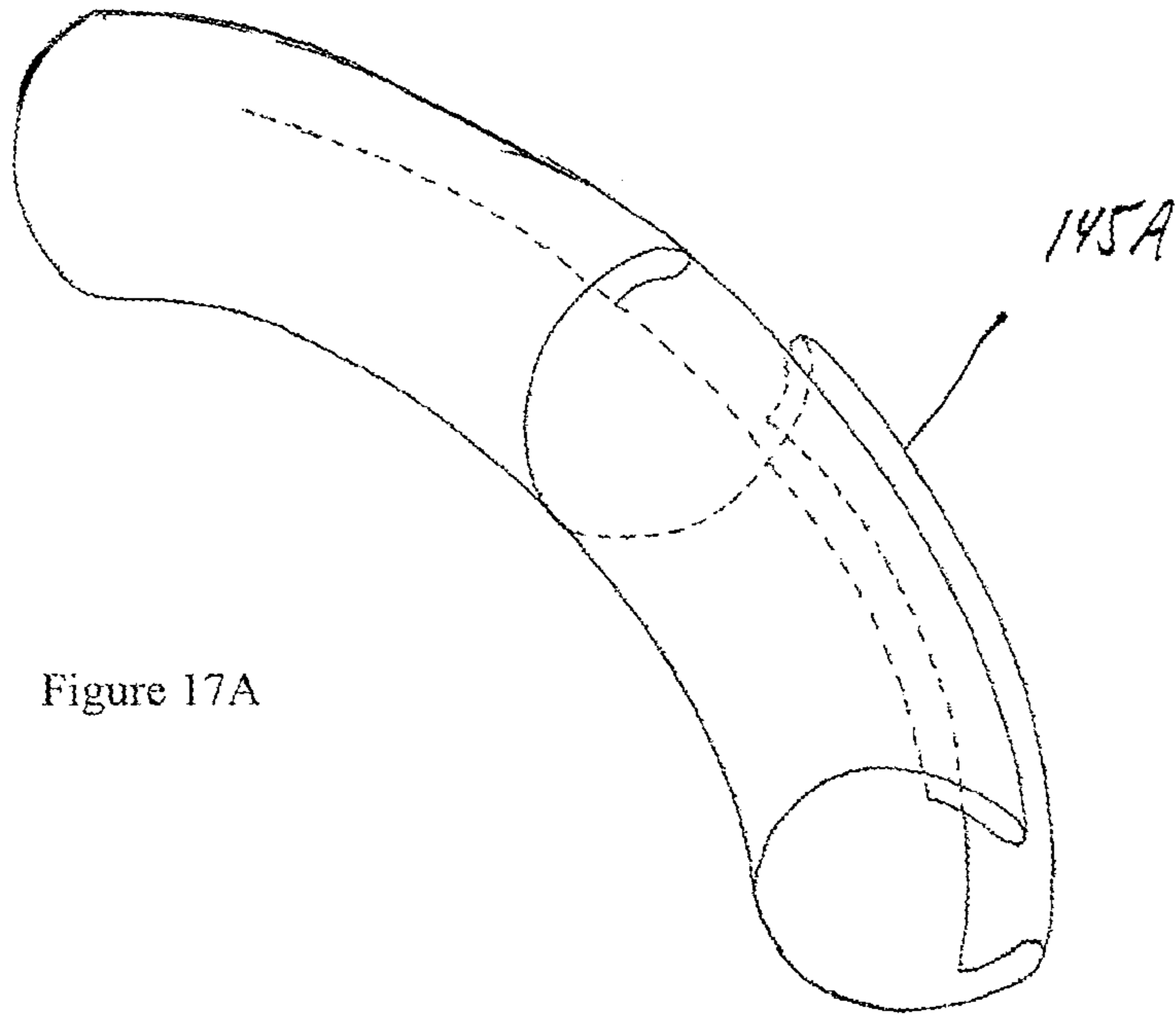

Figure 17A

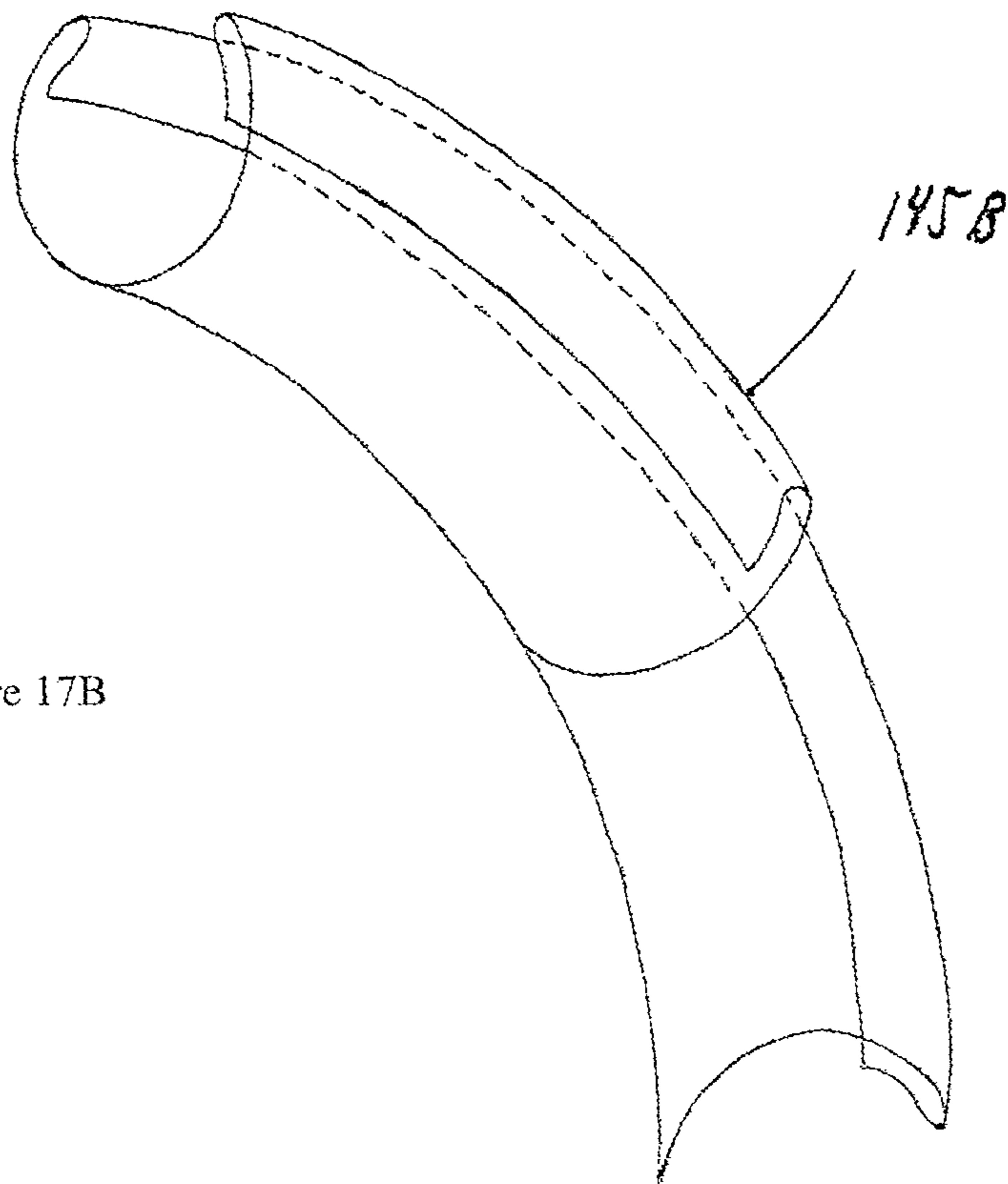

Figure 17B

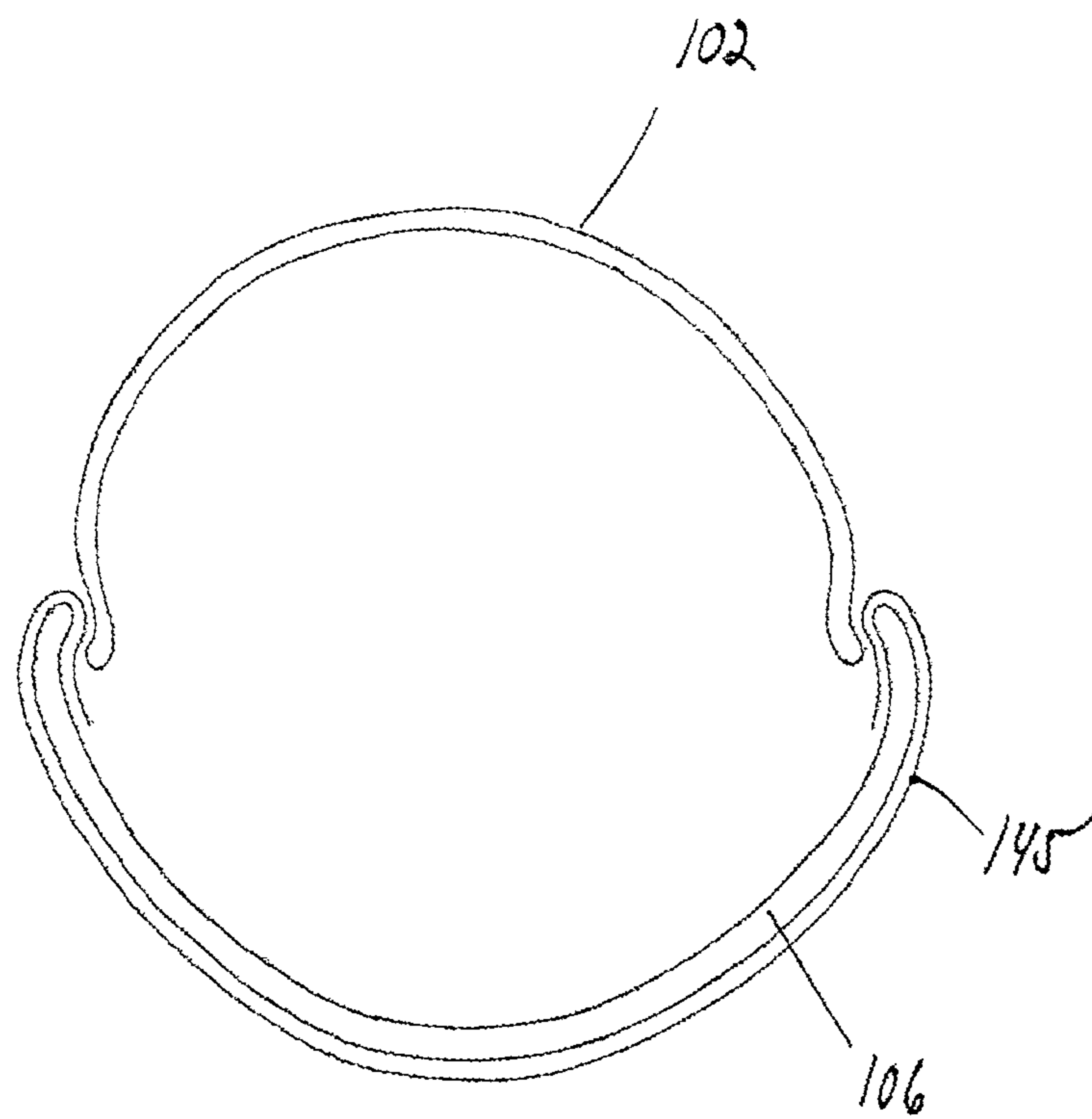

Figure 18

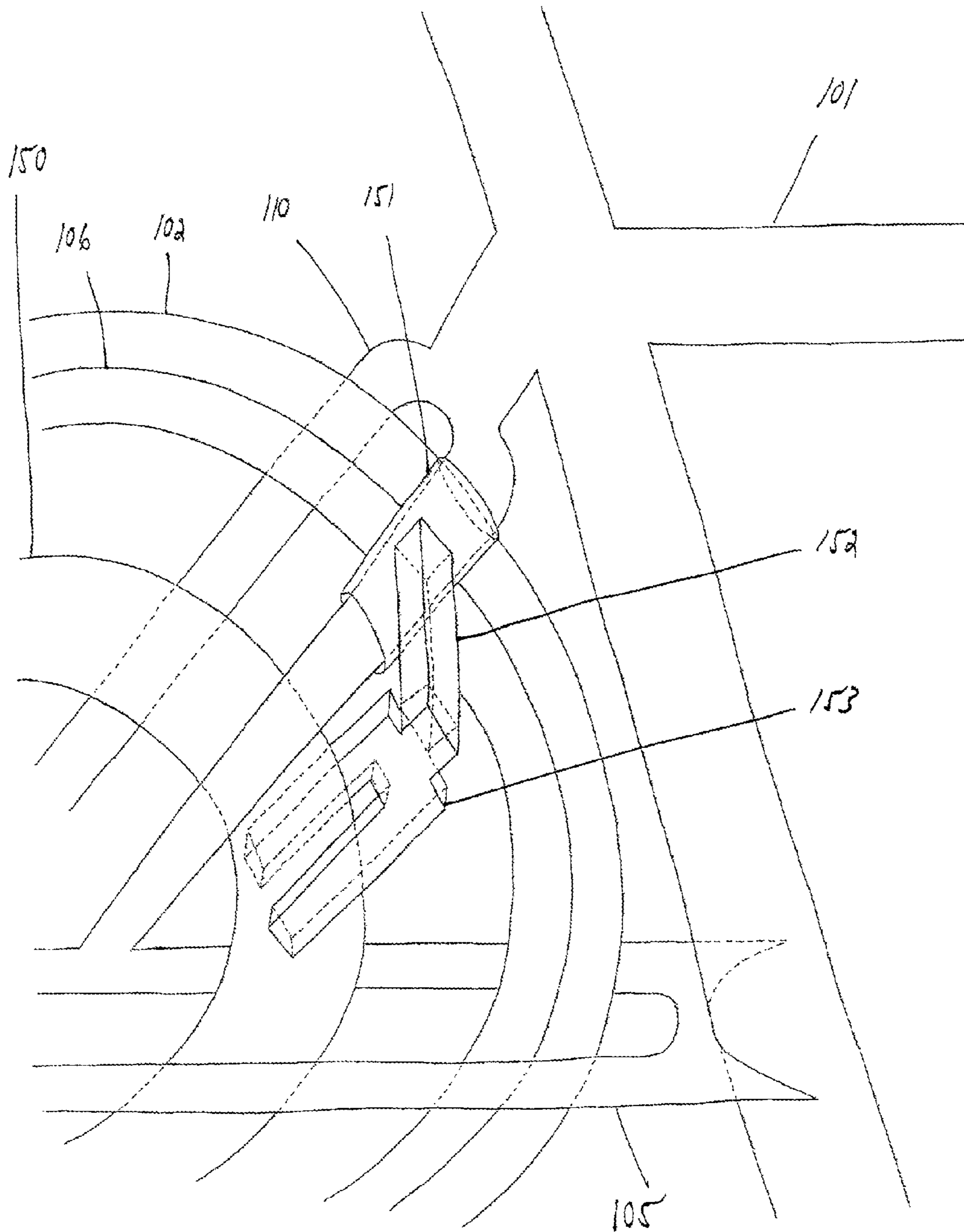

Figure 19

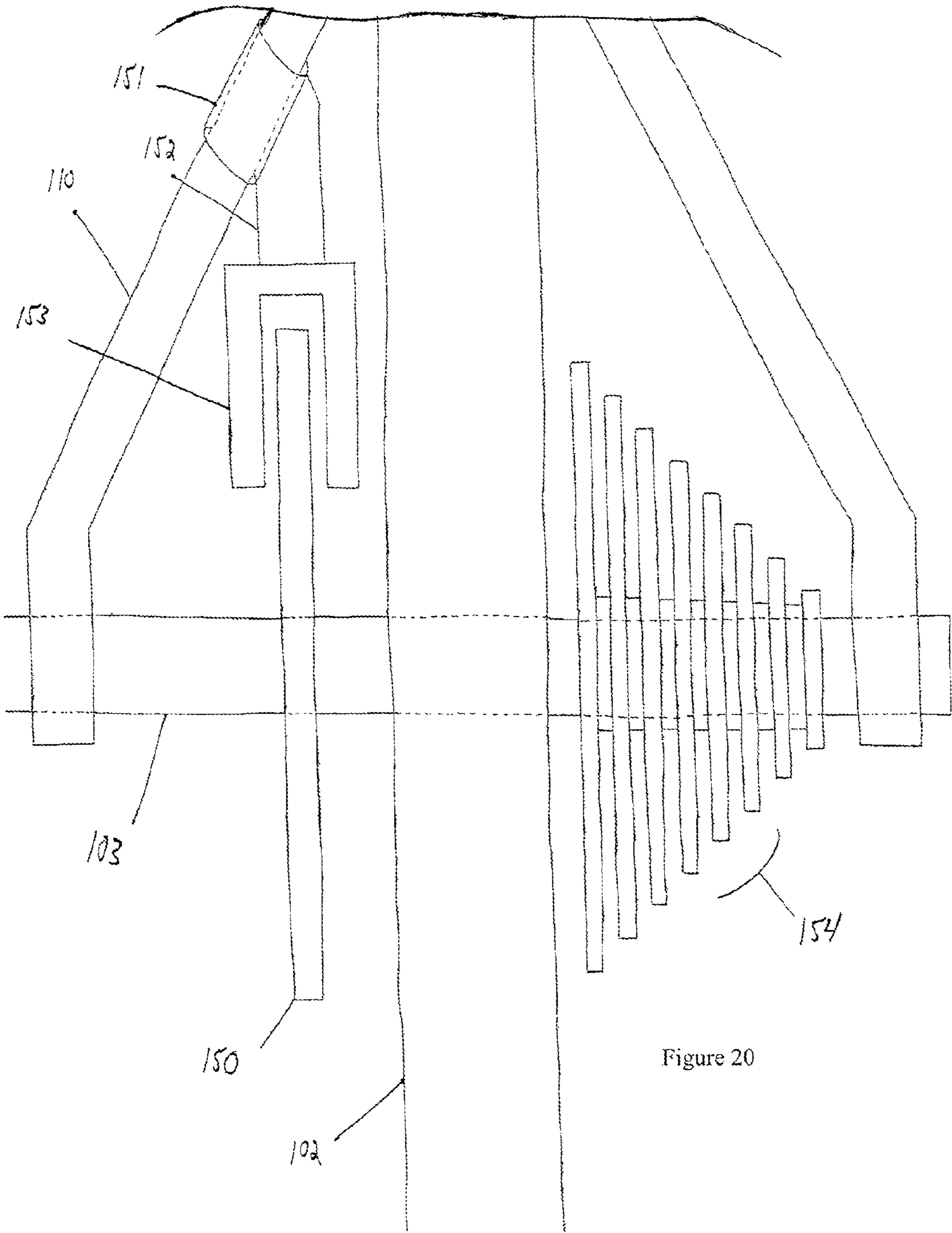

Figure 20

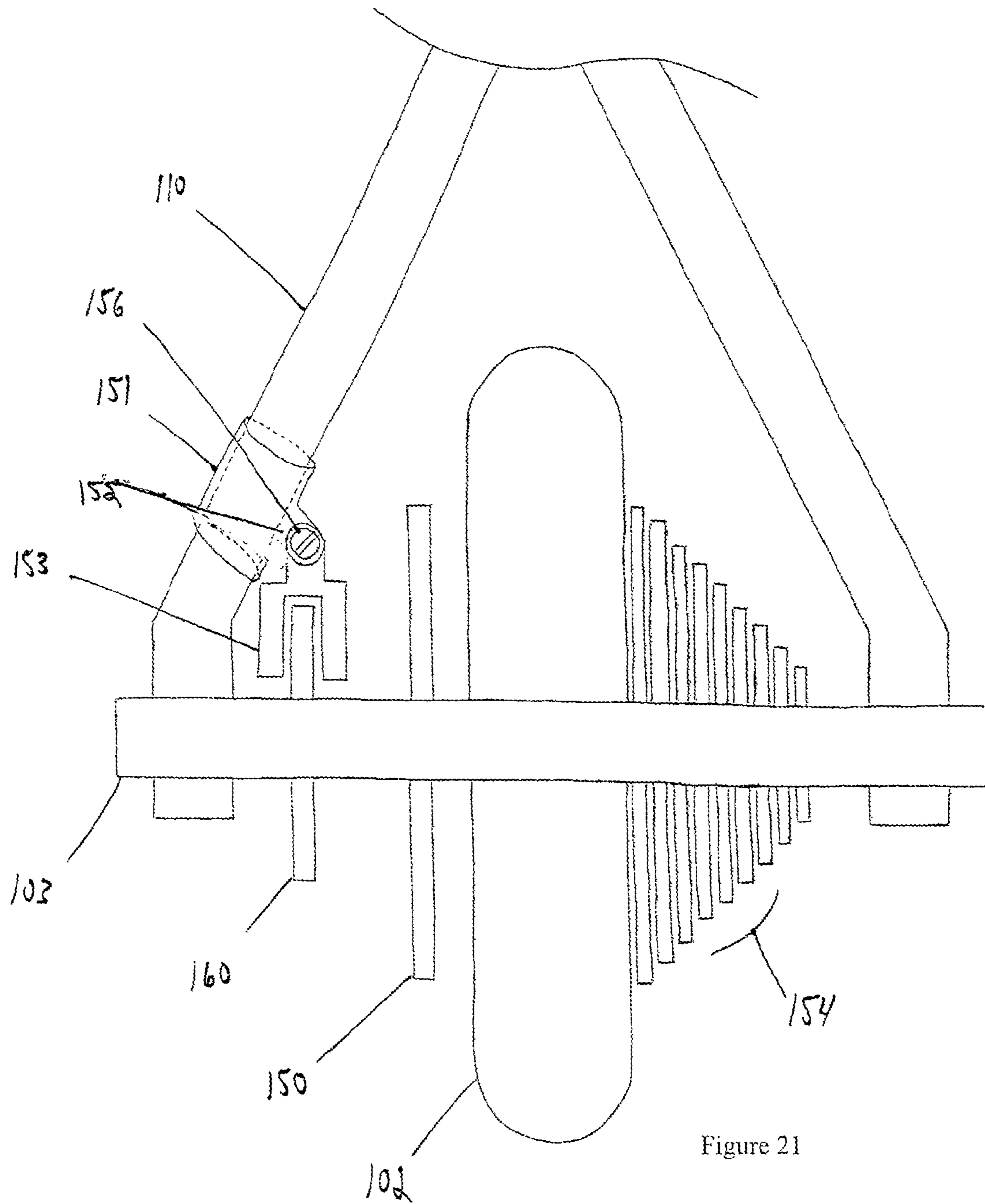

Figure 21

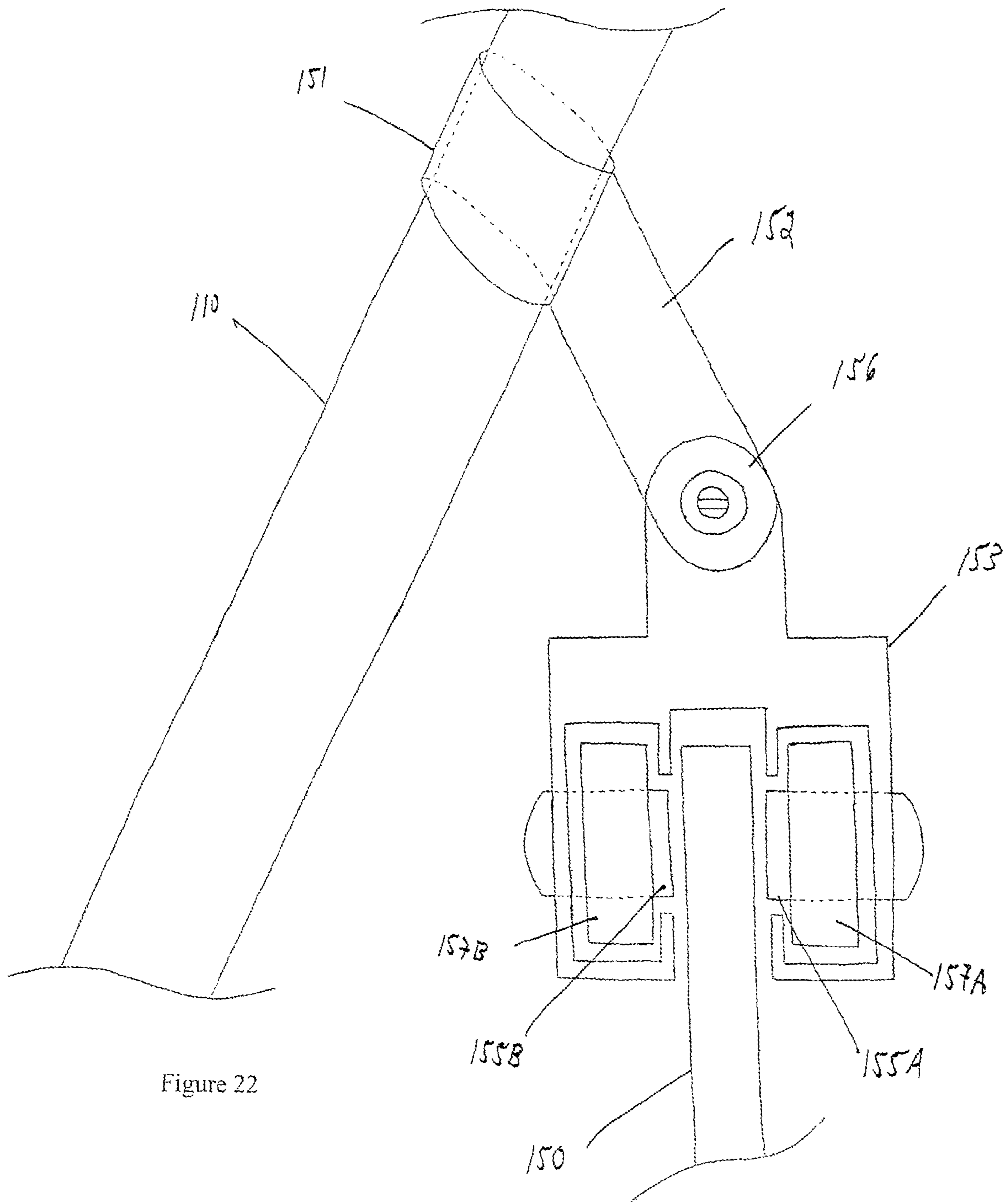

Figure 22



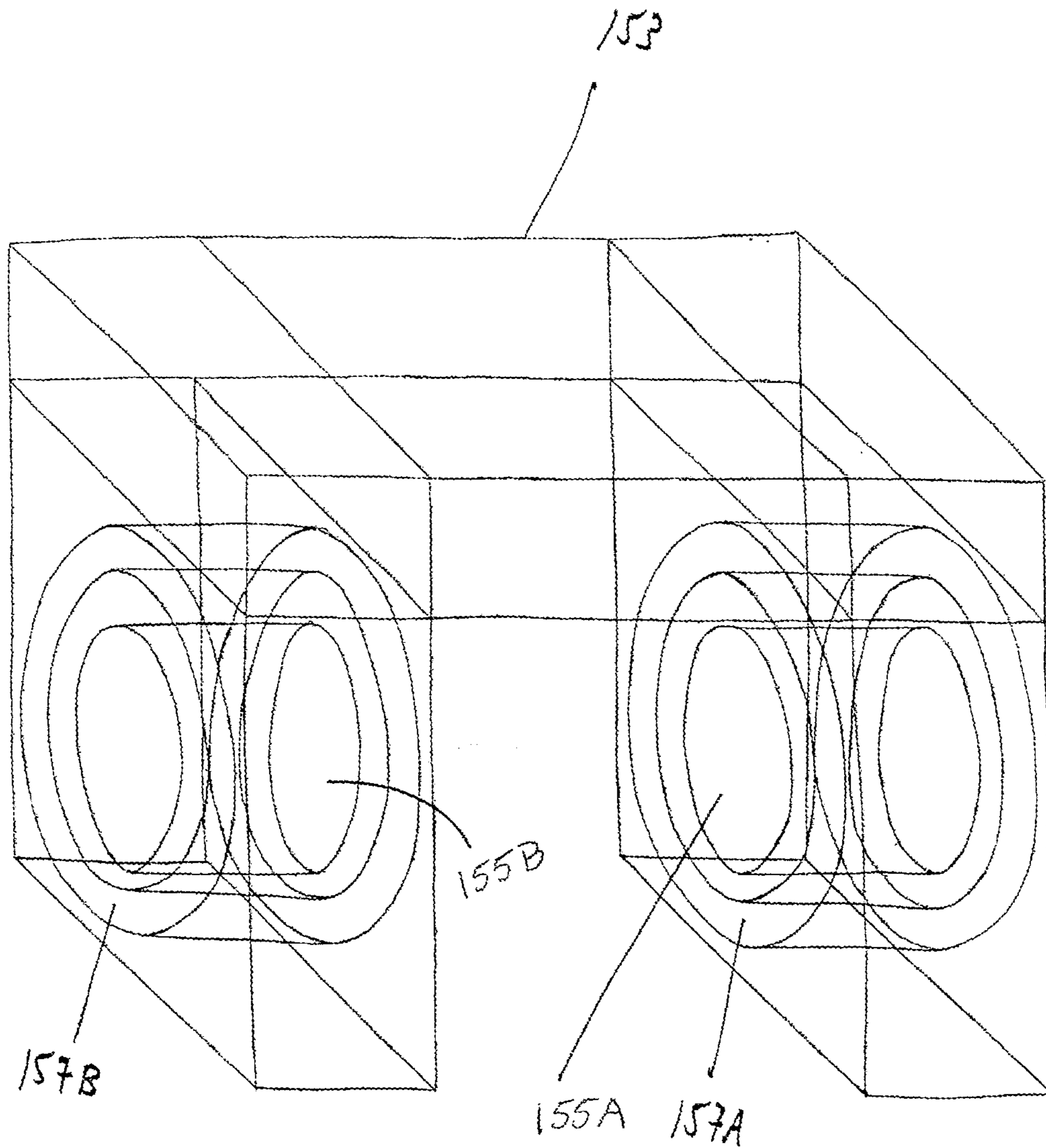

Figure 23

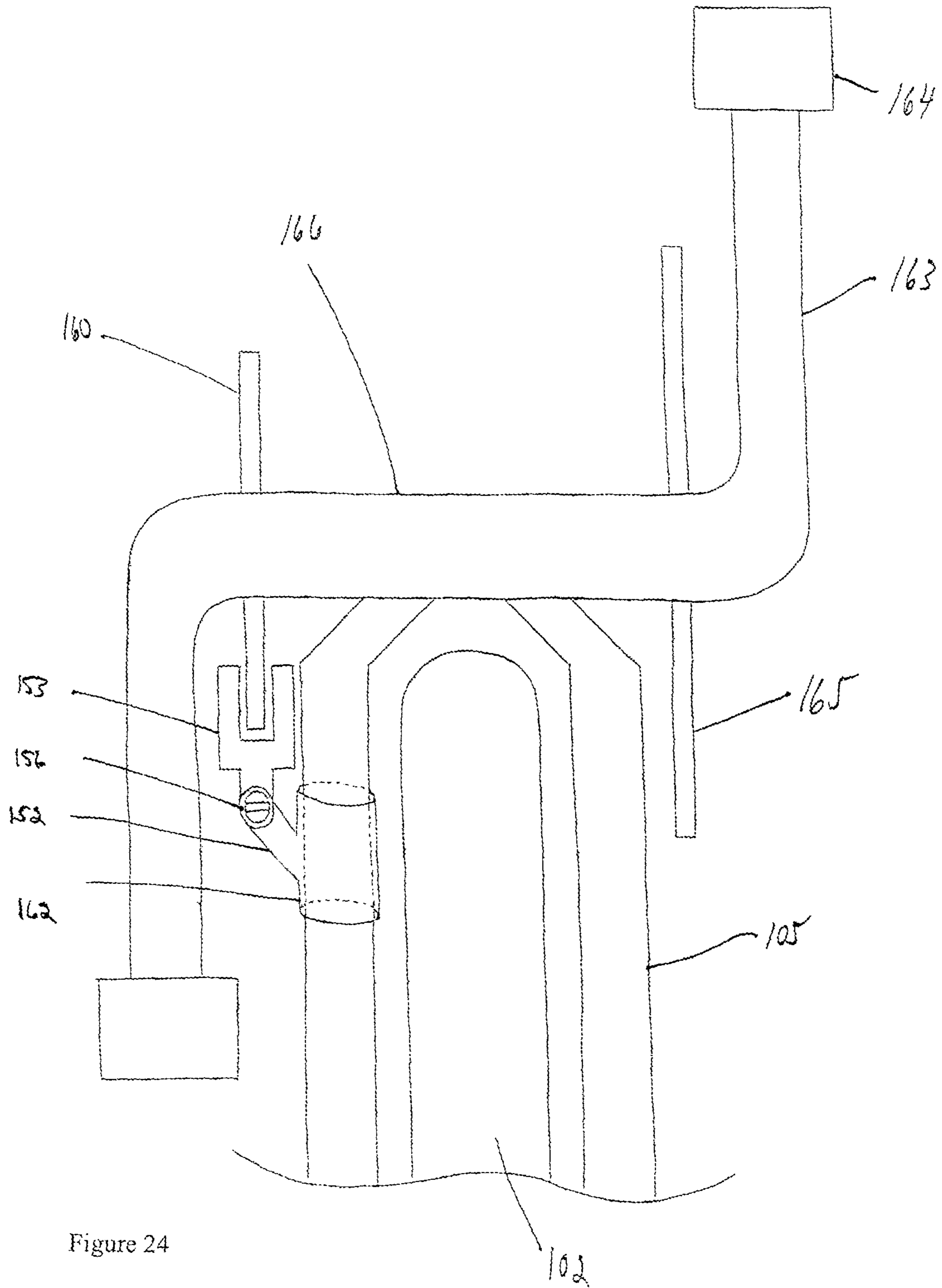

Figure 24

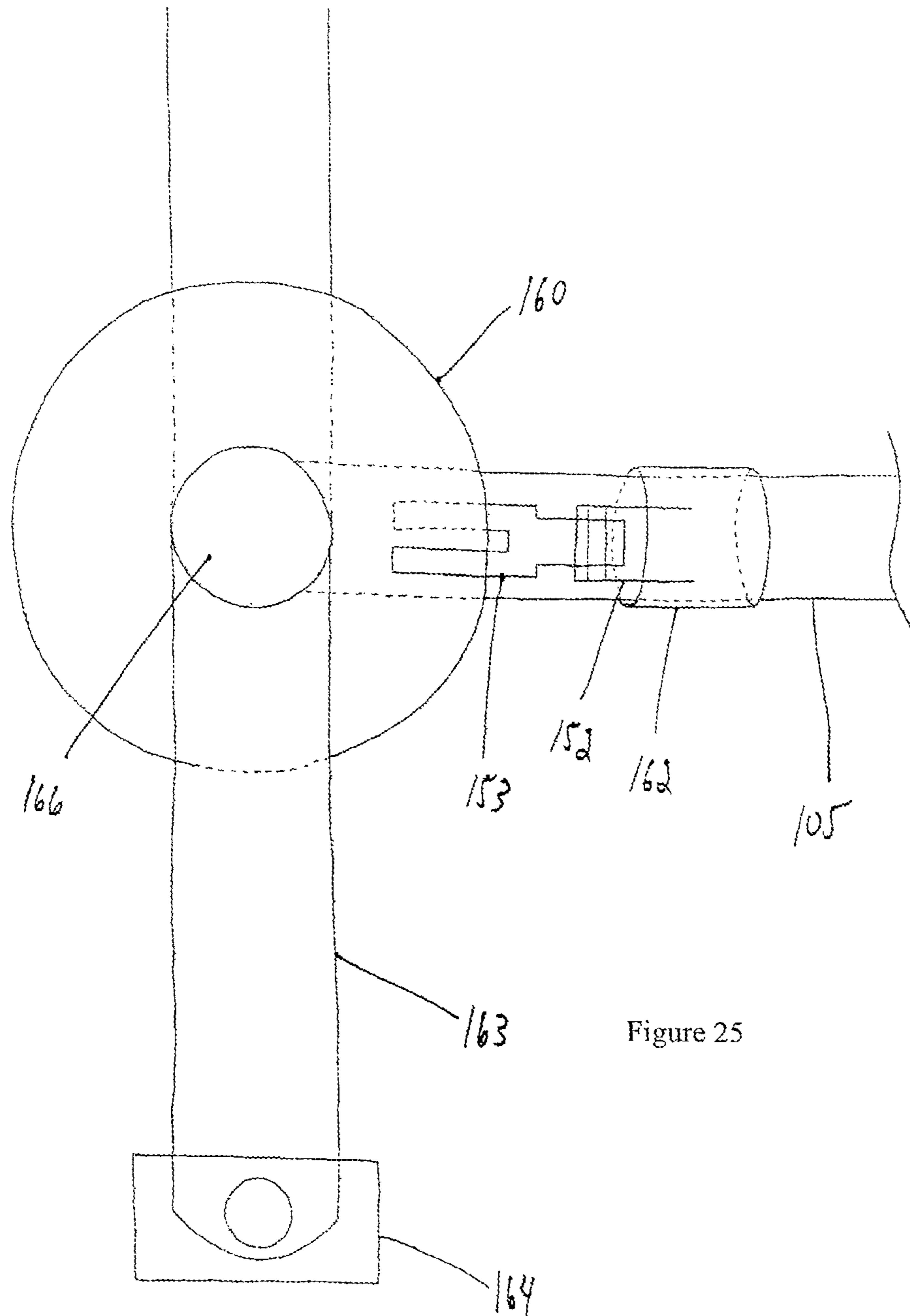

Figure 25

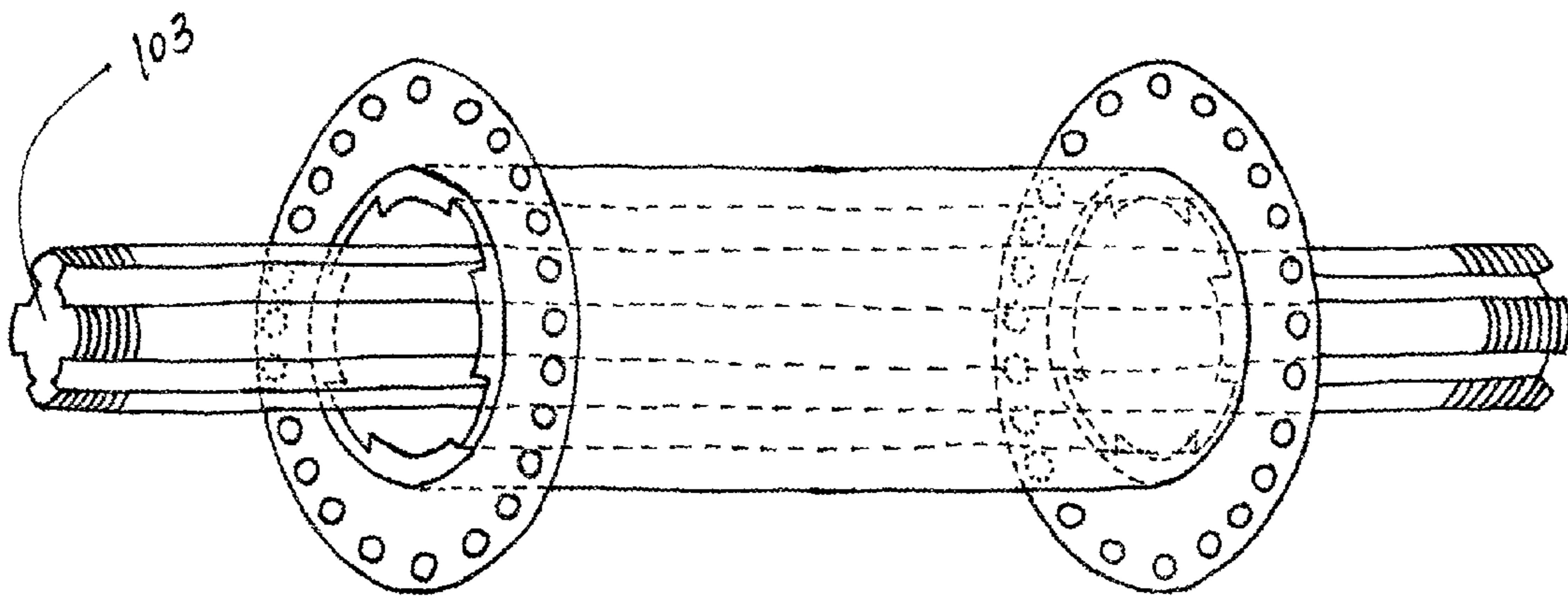

Figure 25A



Figure 25B

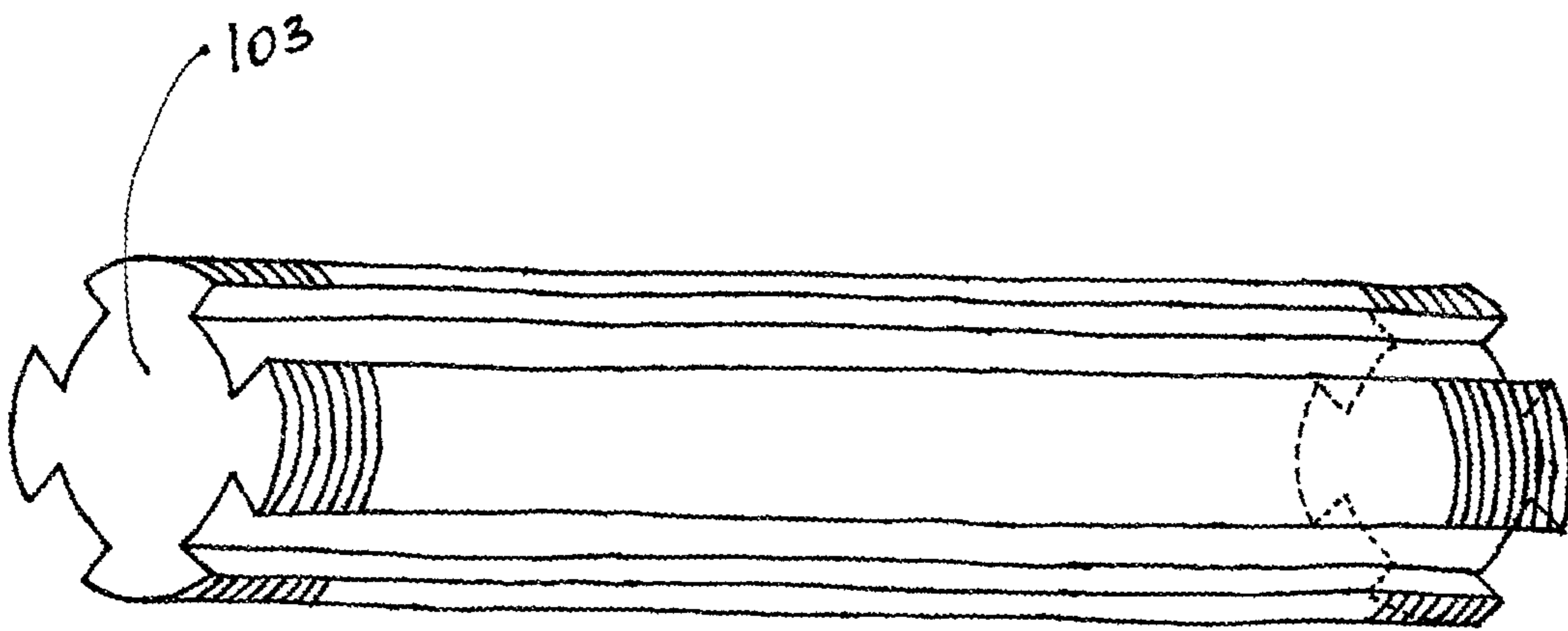

Figure 25C

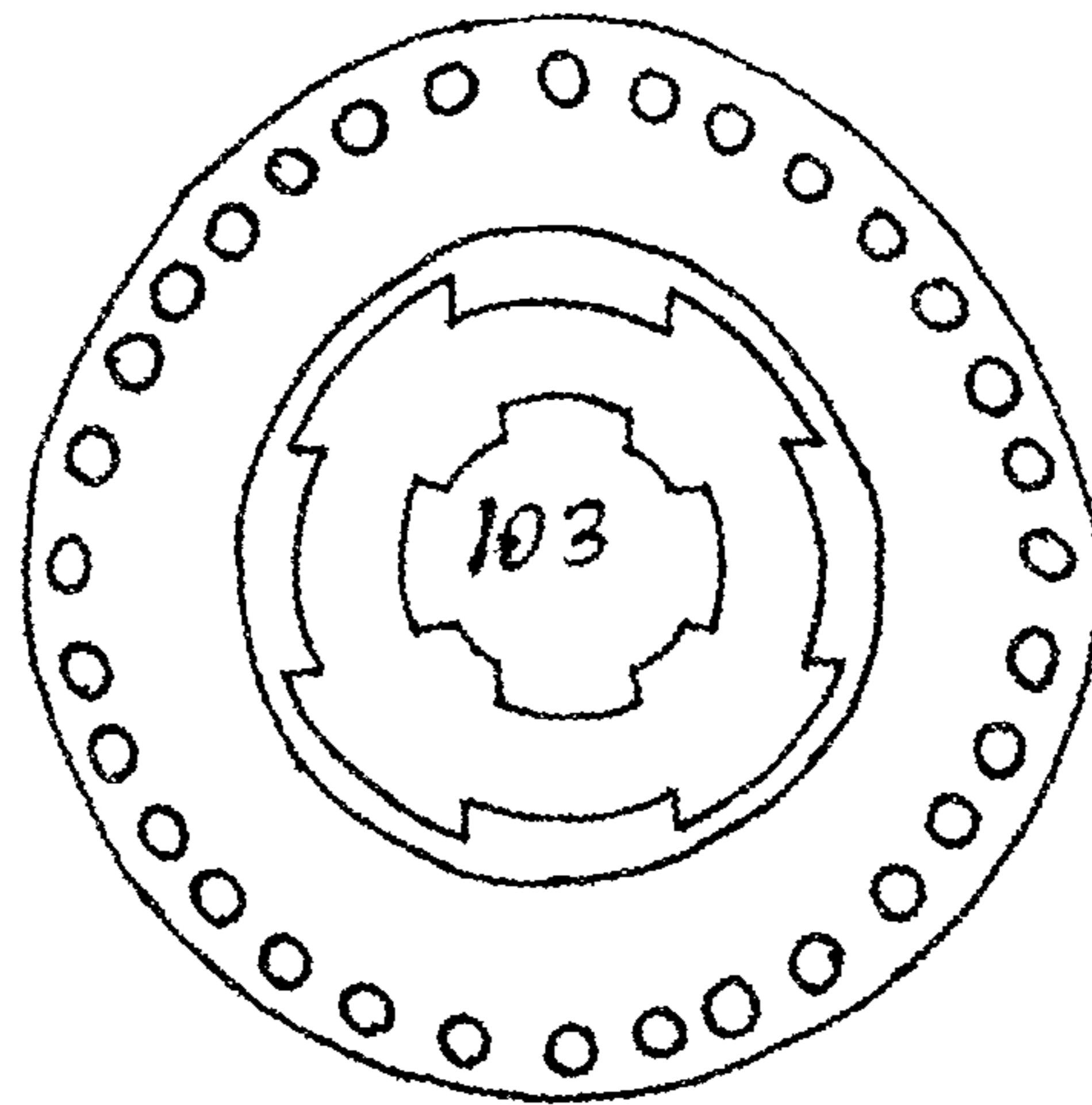

Figure 25D

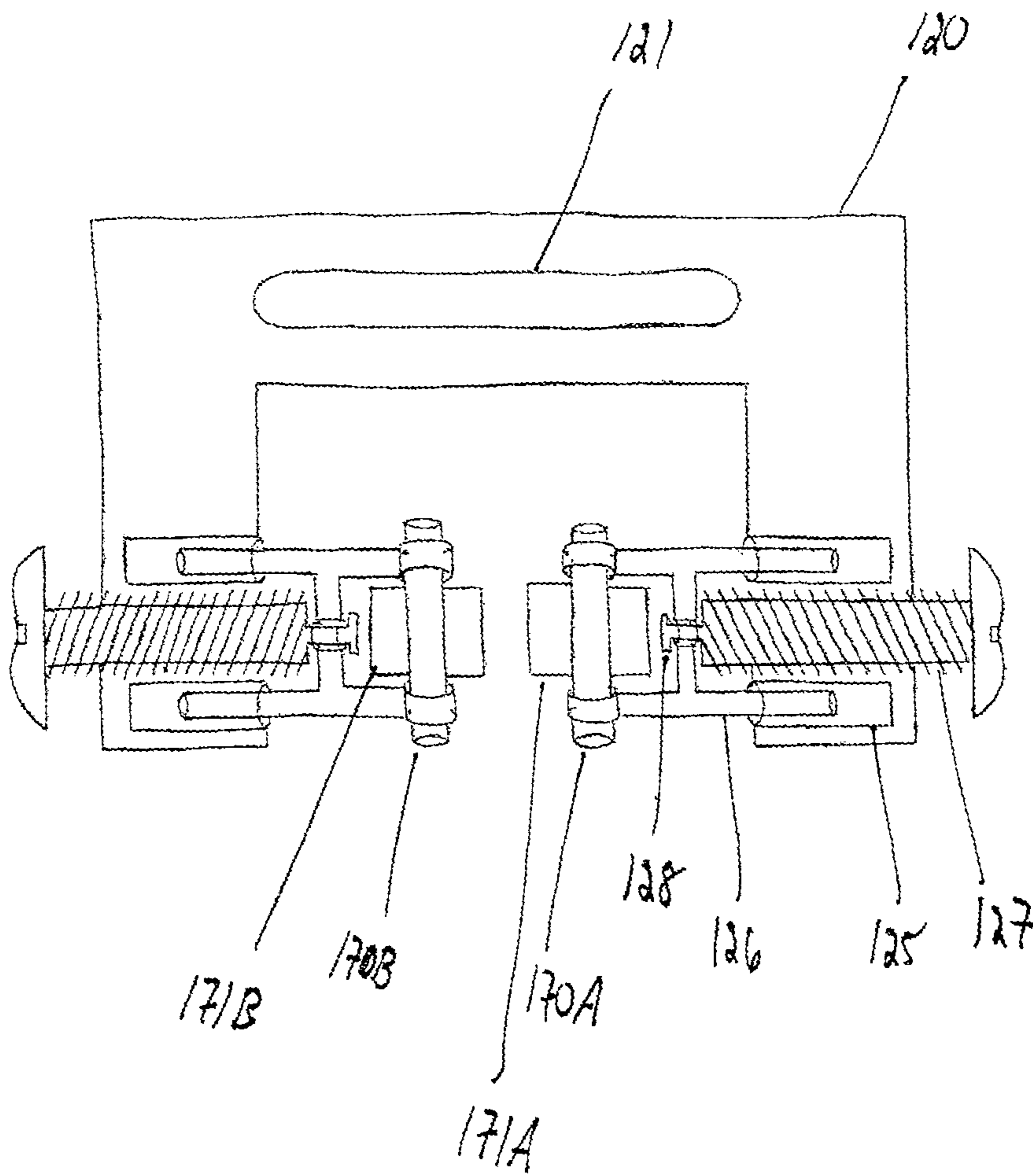

Figure 26

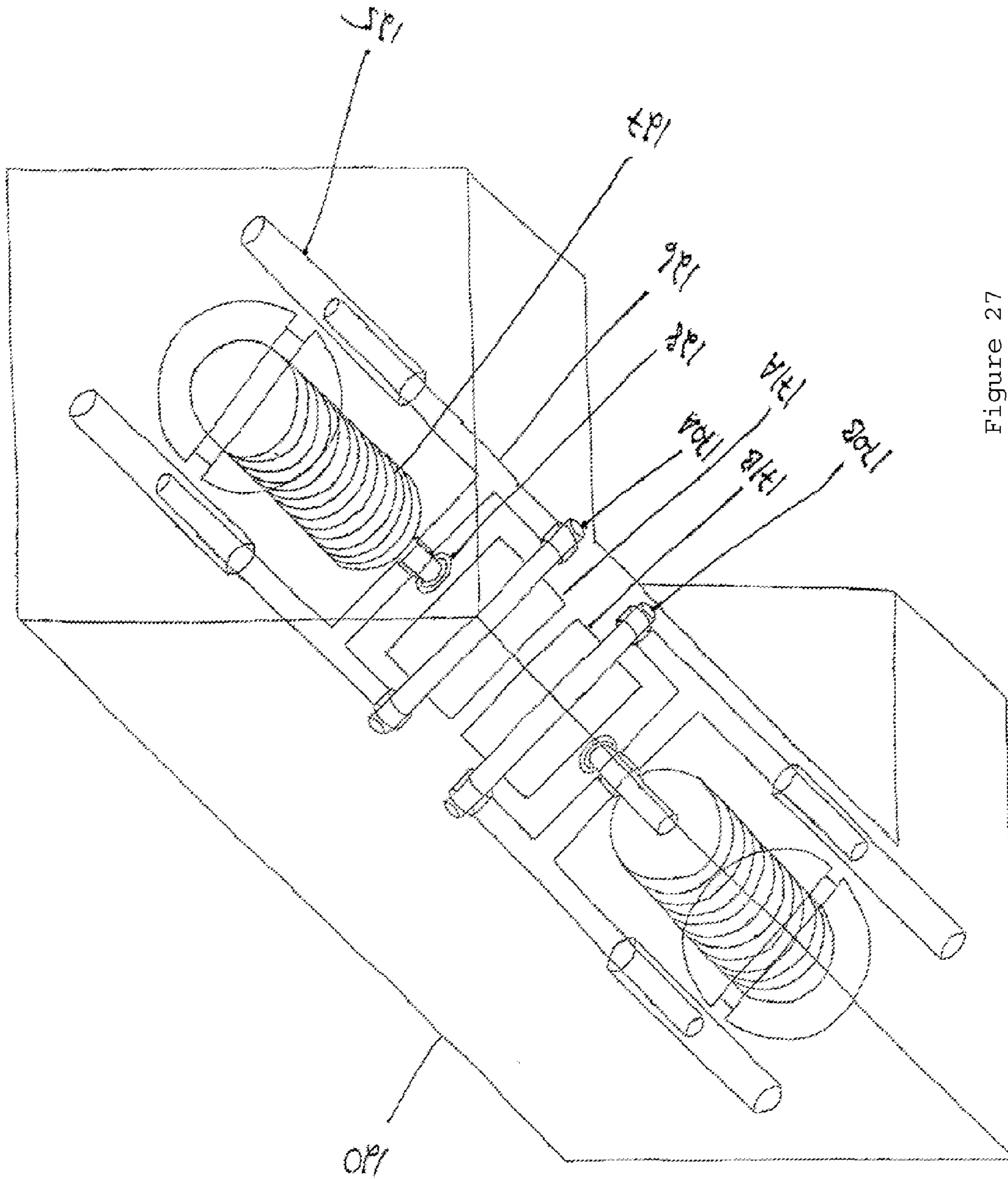

Figure 27



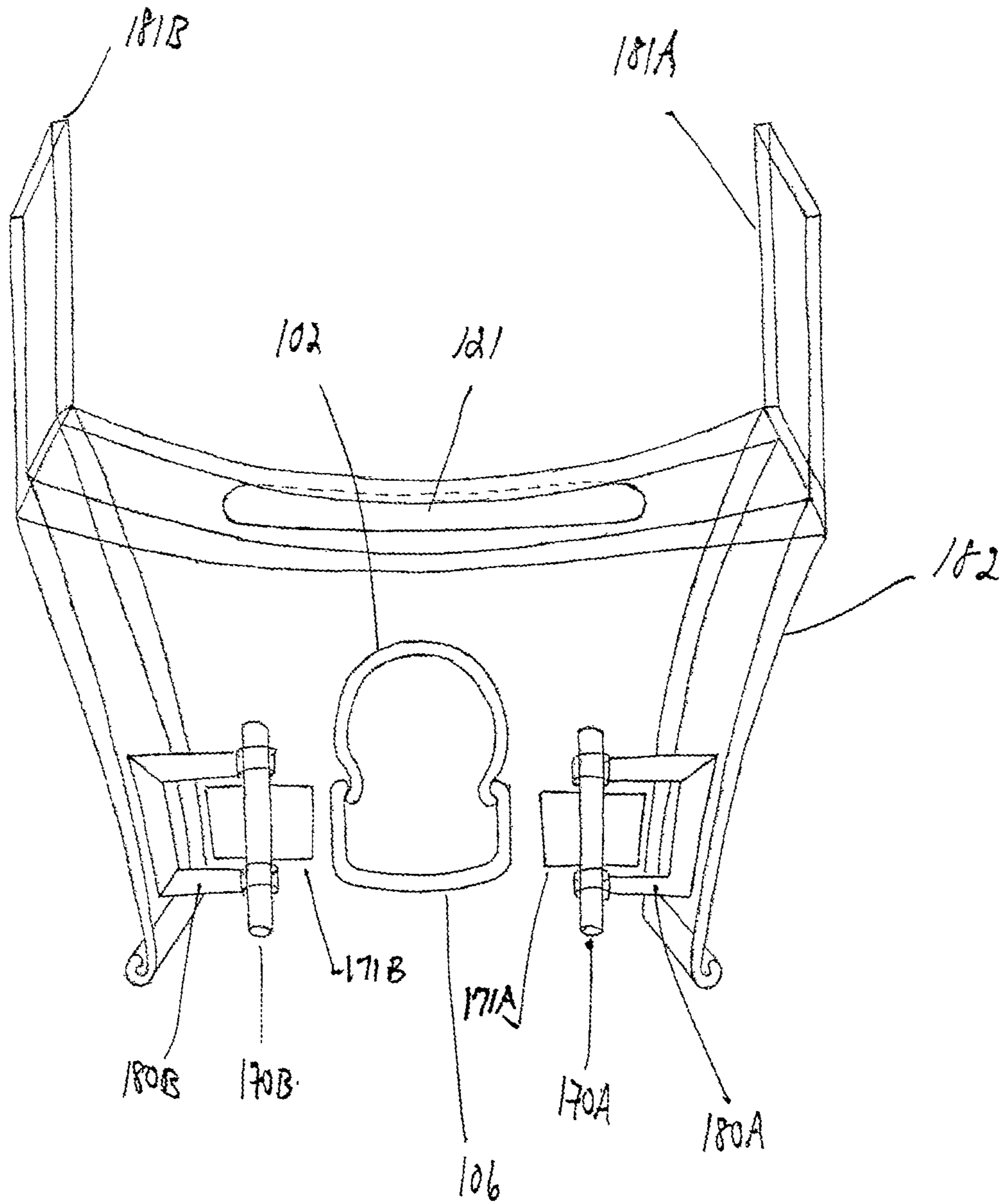

Figure 28

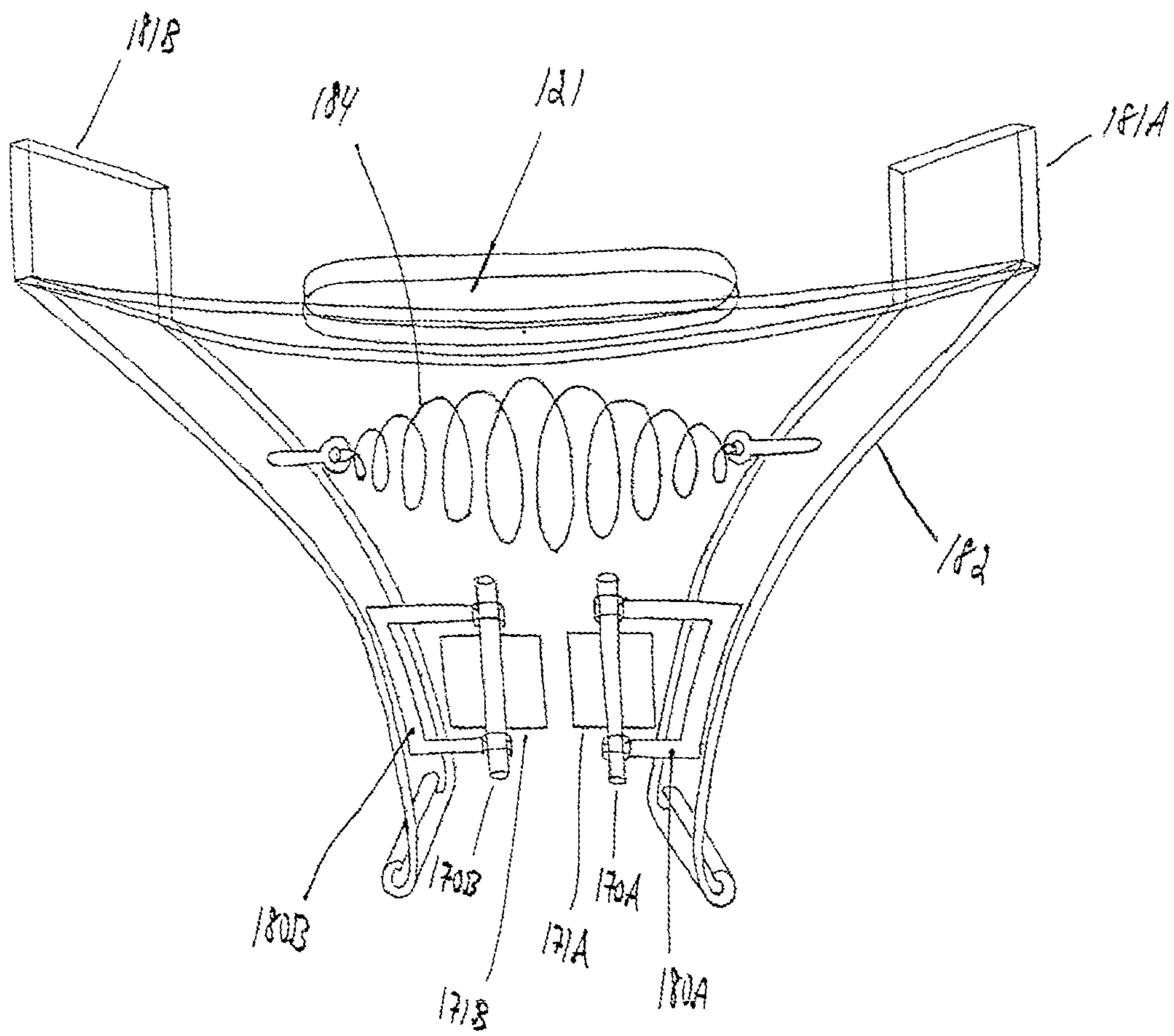

Figure 29

Figure 30A

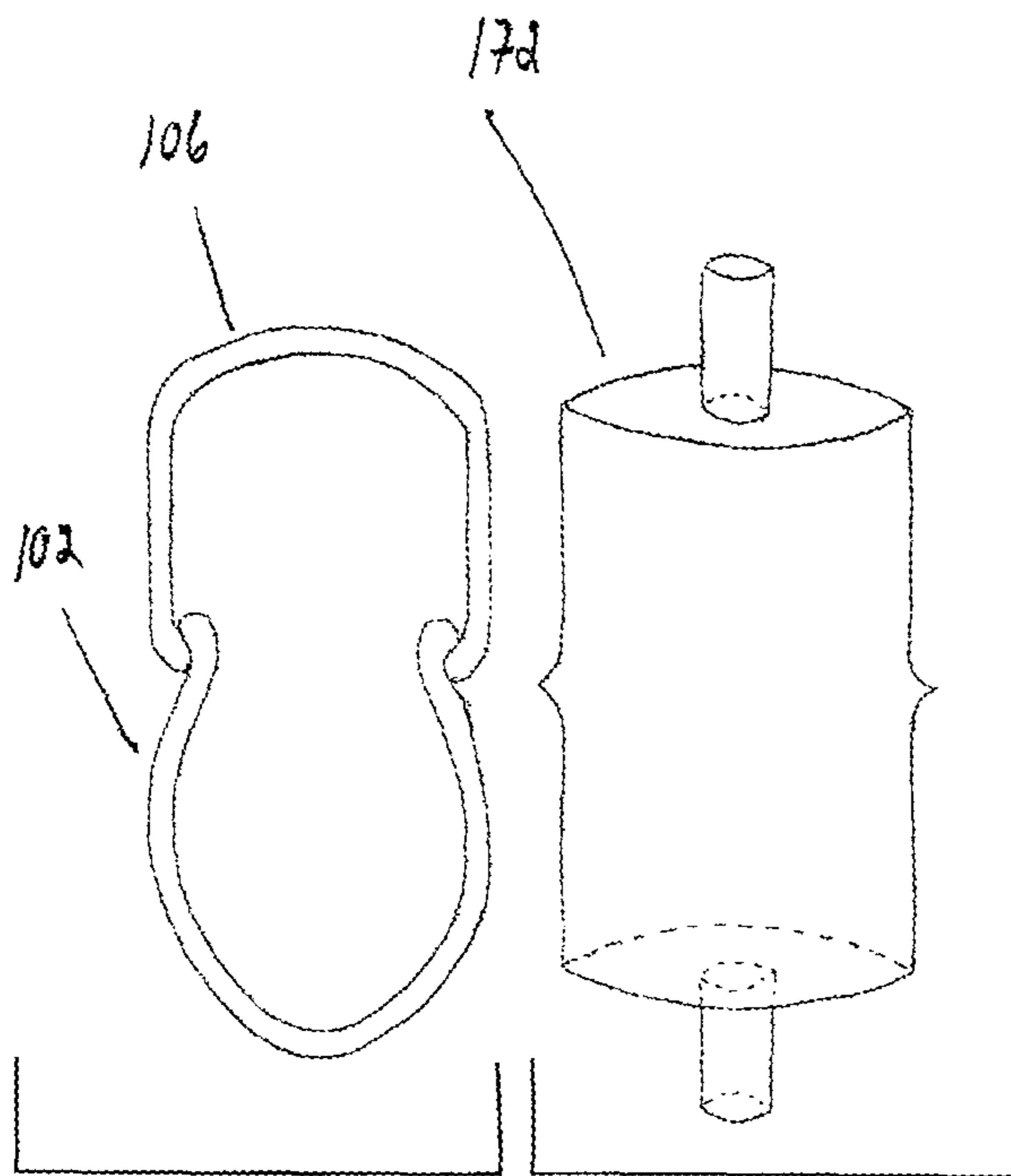
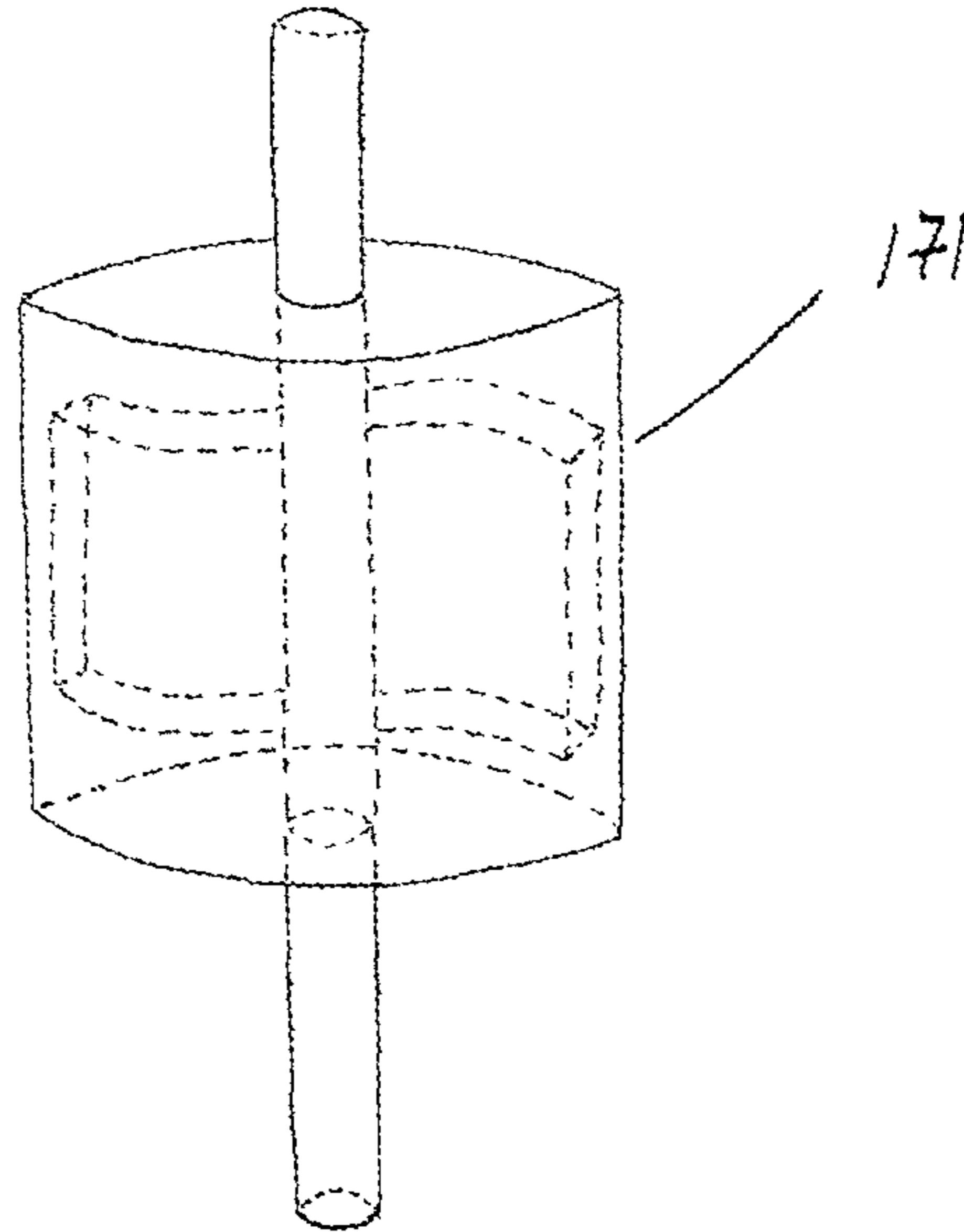

Figure 30B

Figure 30C

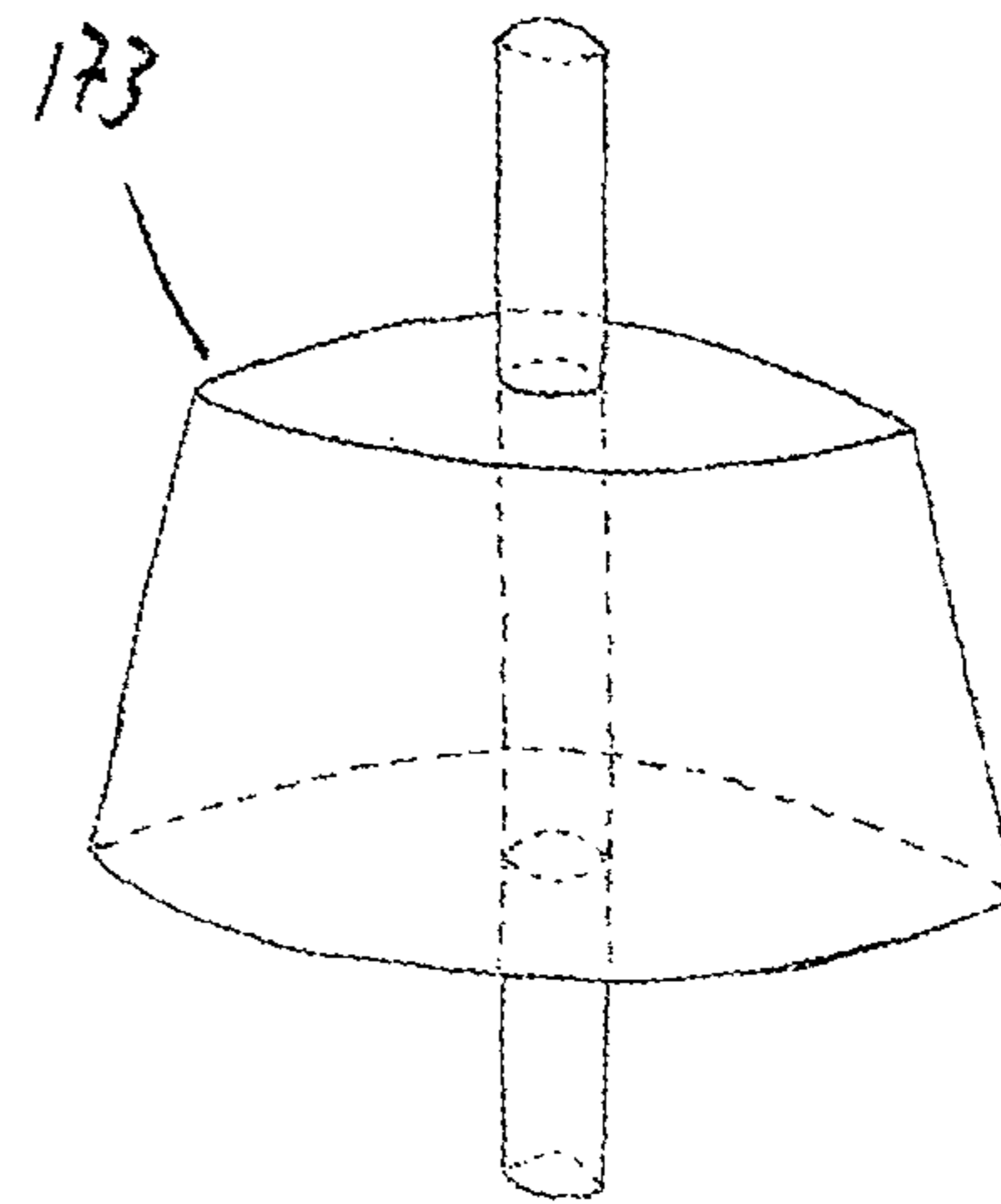

Figure 30D

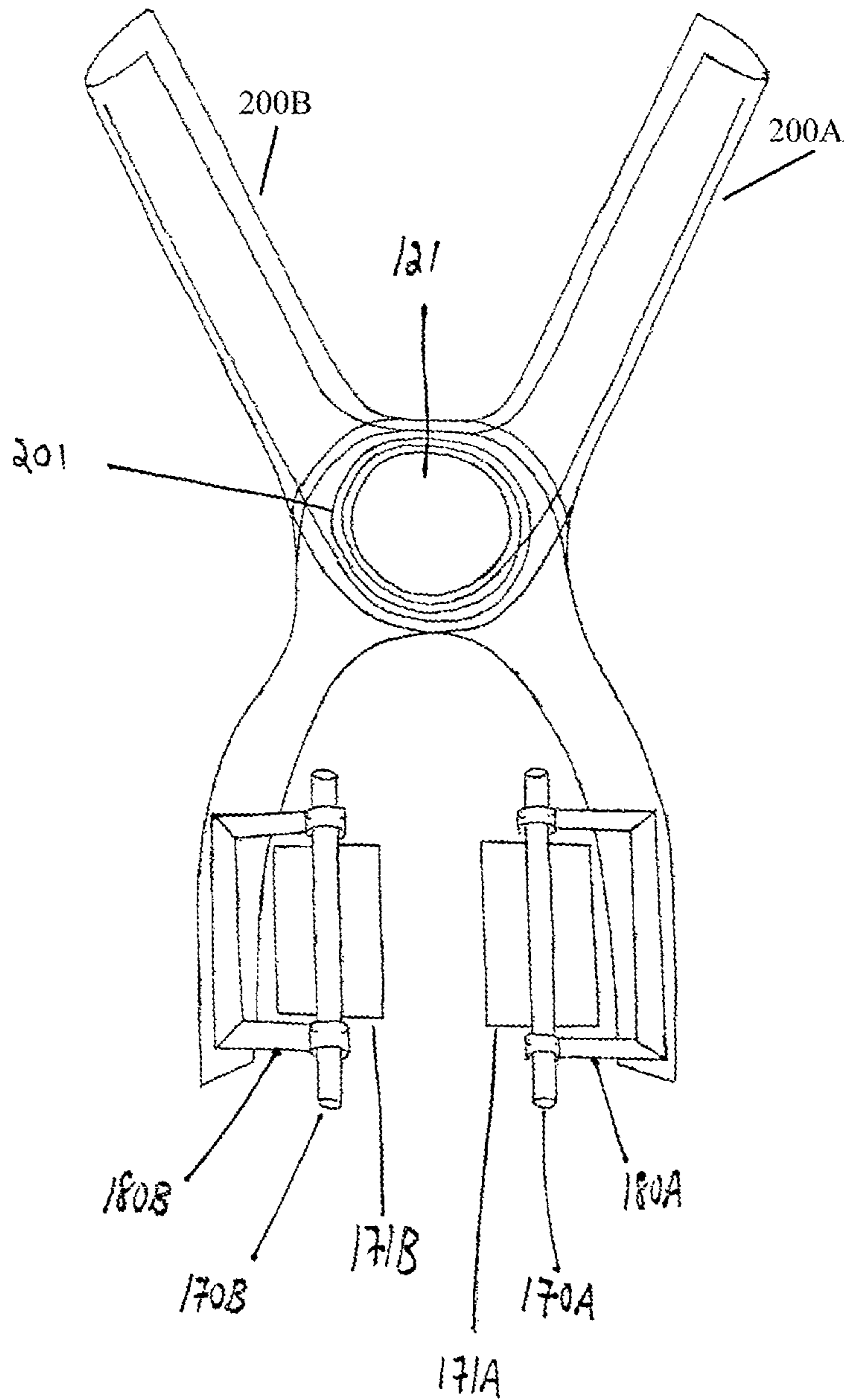

Figure 31

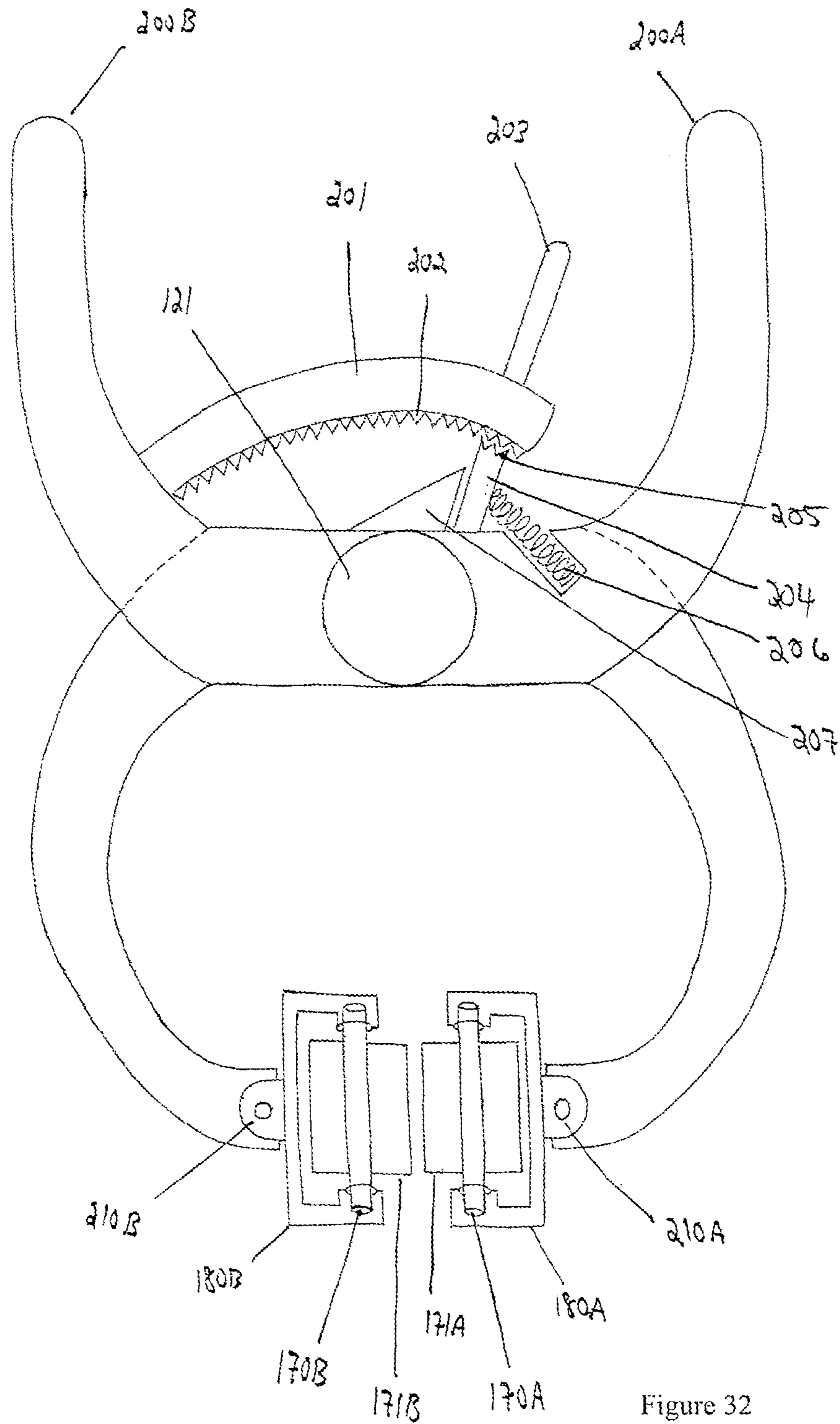

Figure 32

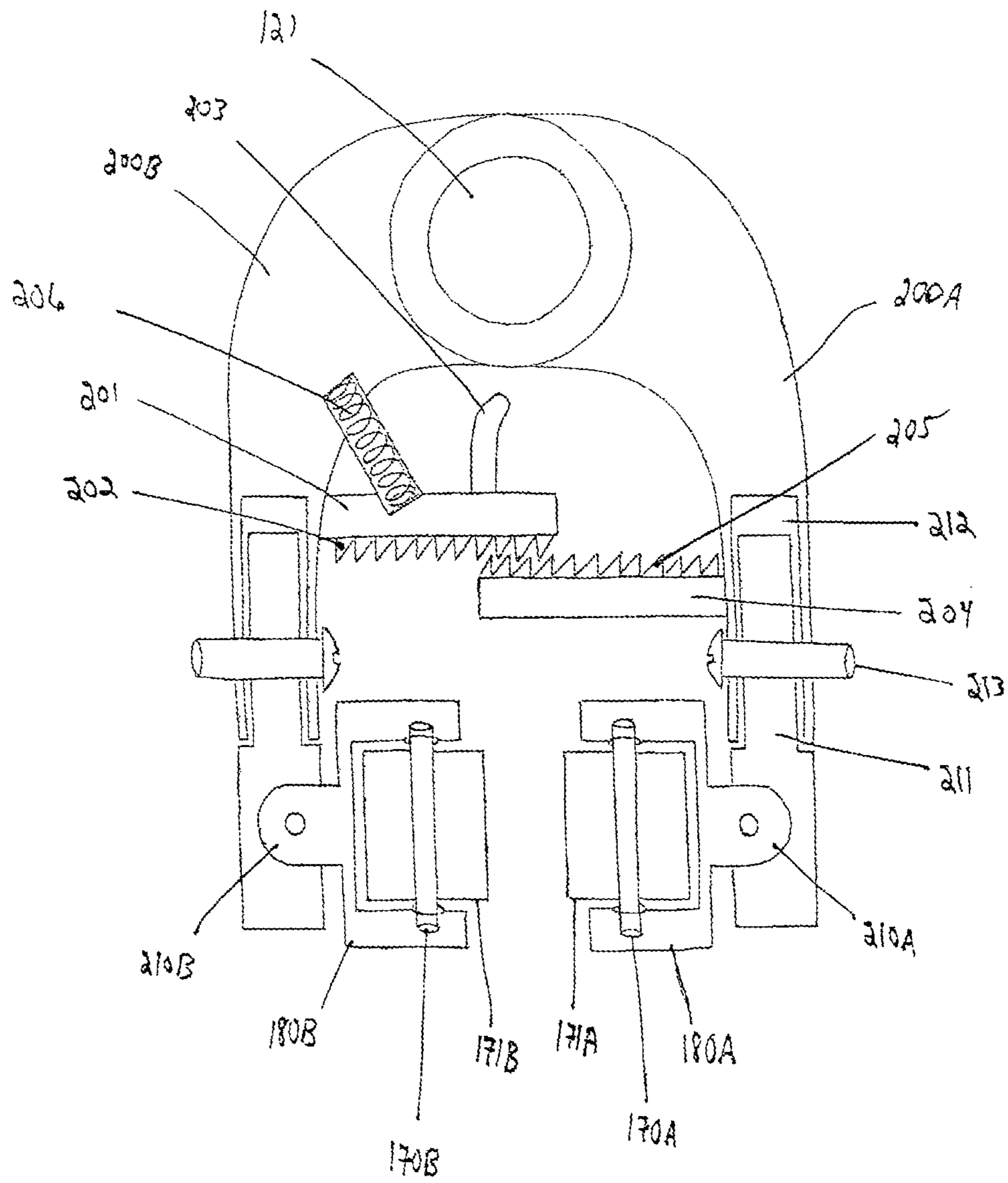

Figure 33

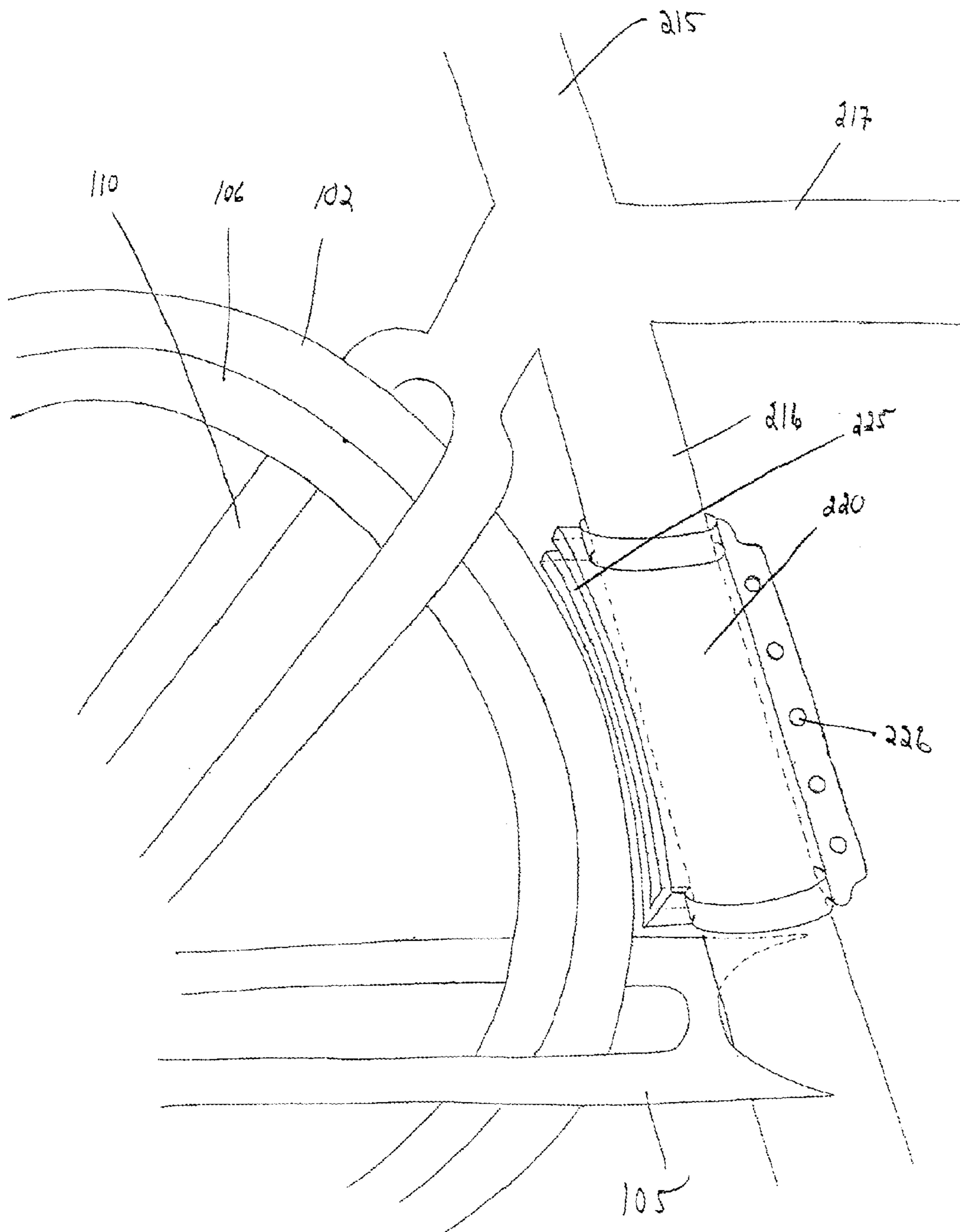

Figure 34

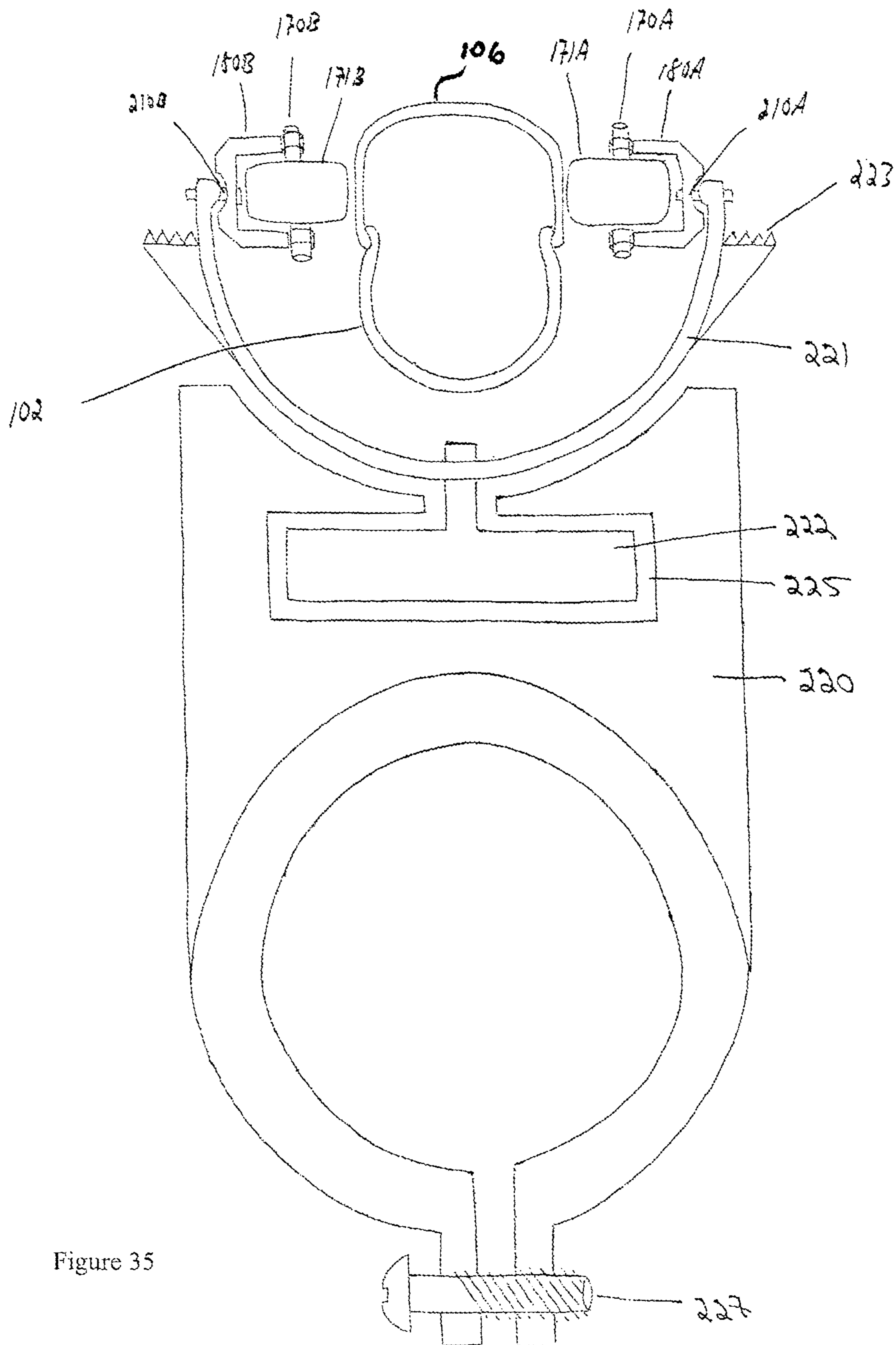

Figure 35



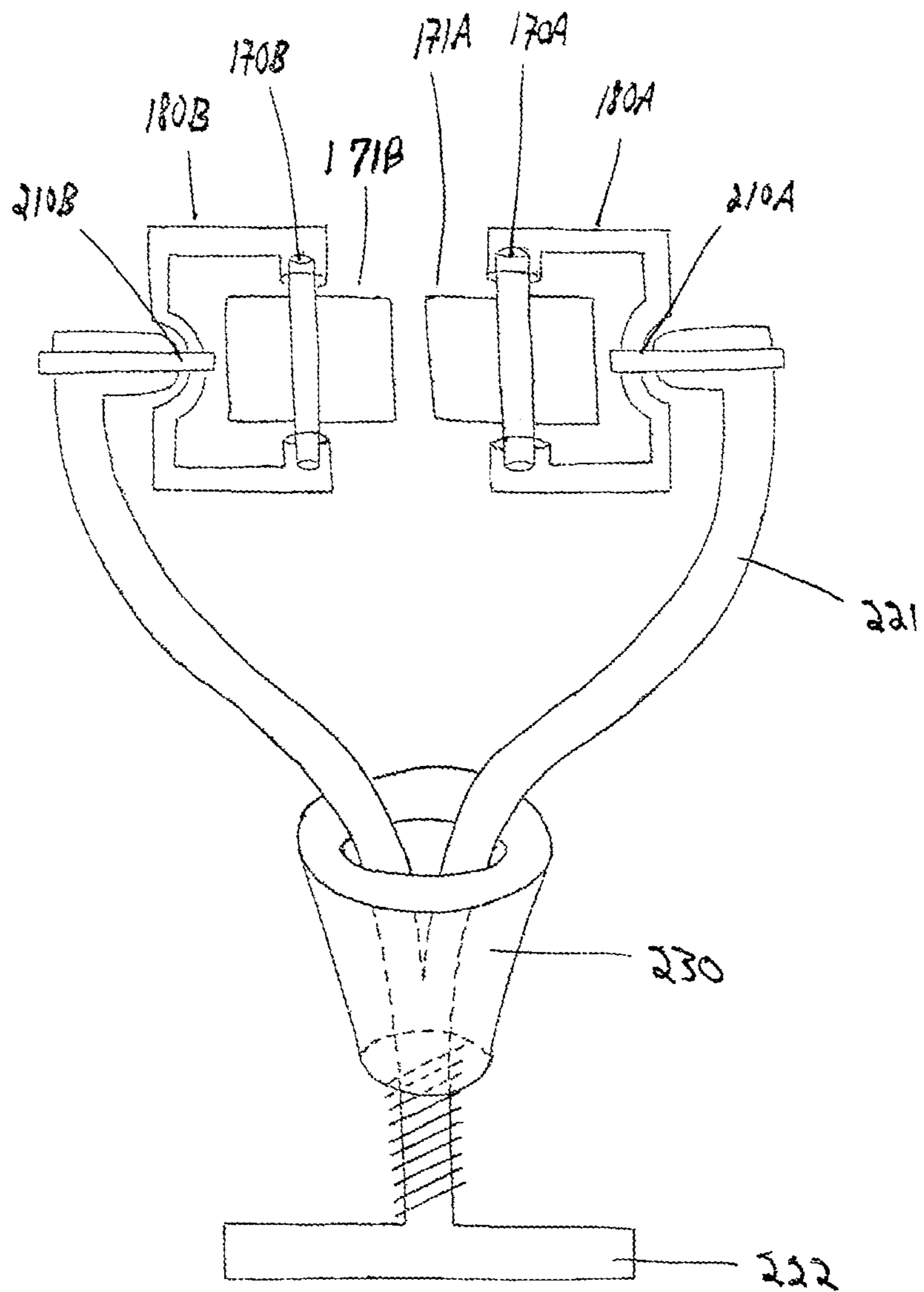

Figure 36

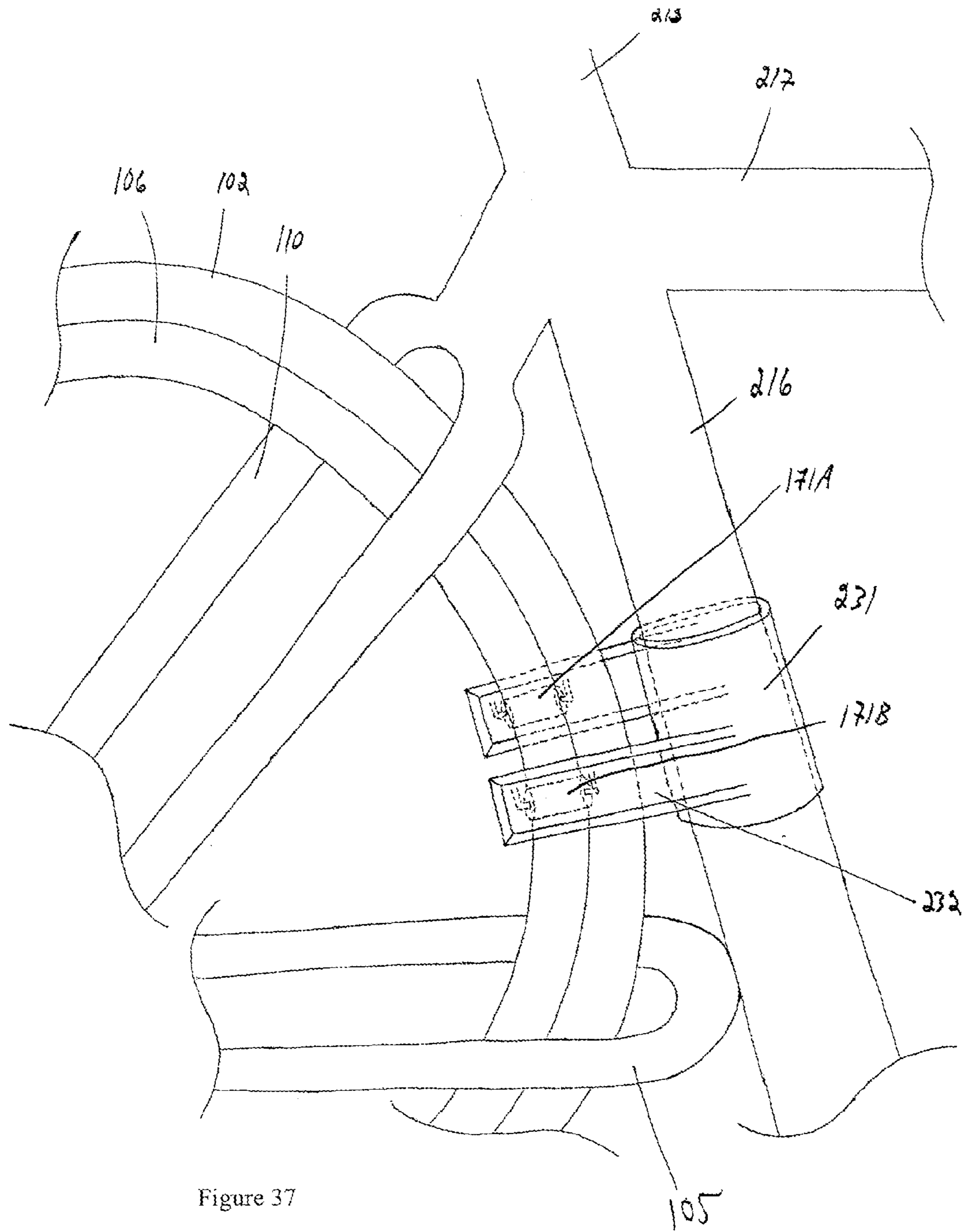

Figure 37

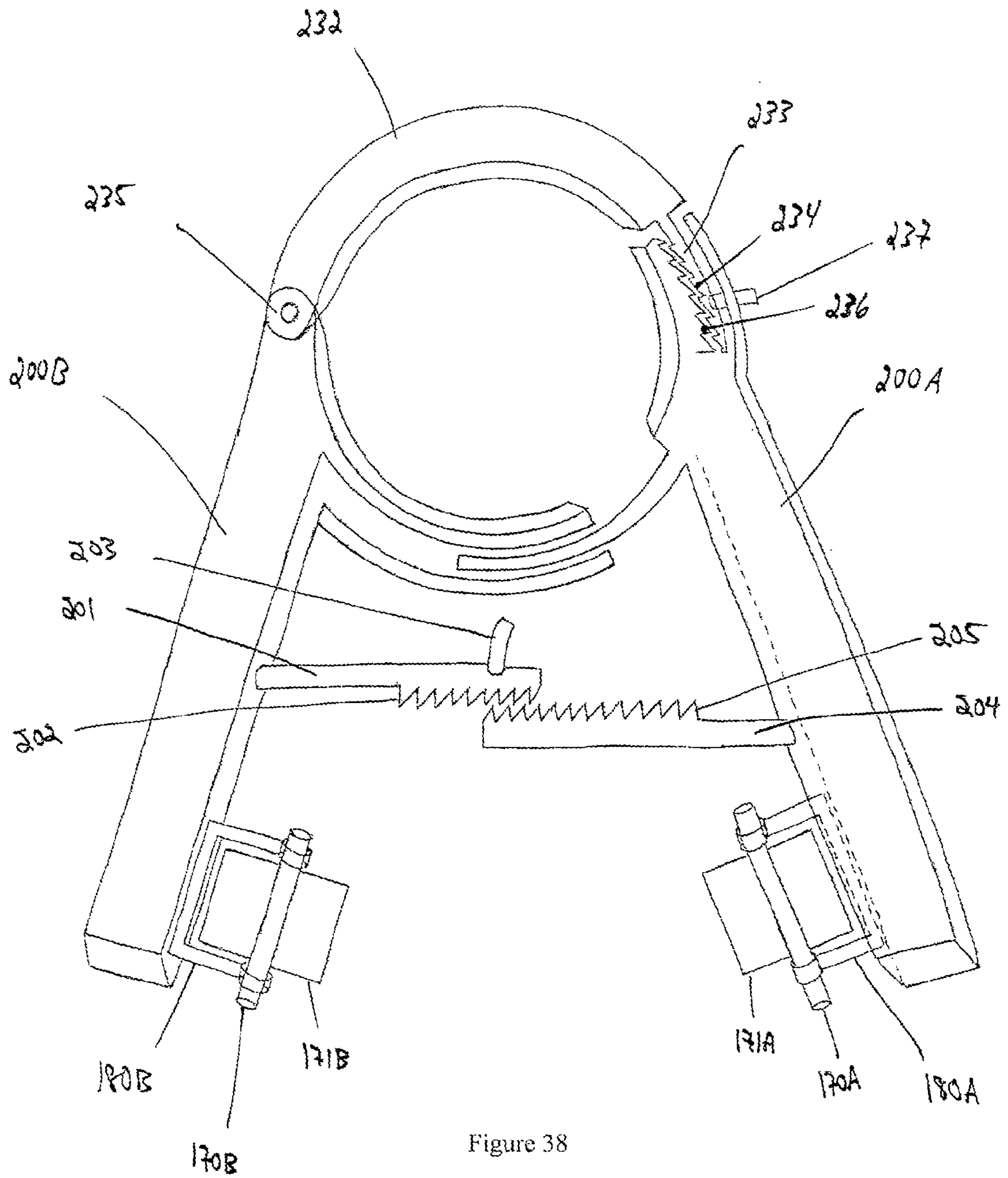

Figure 38

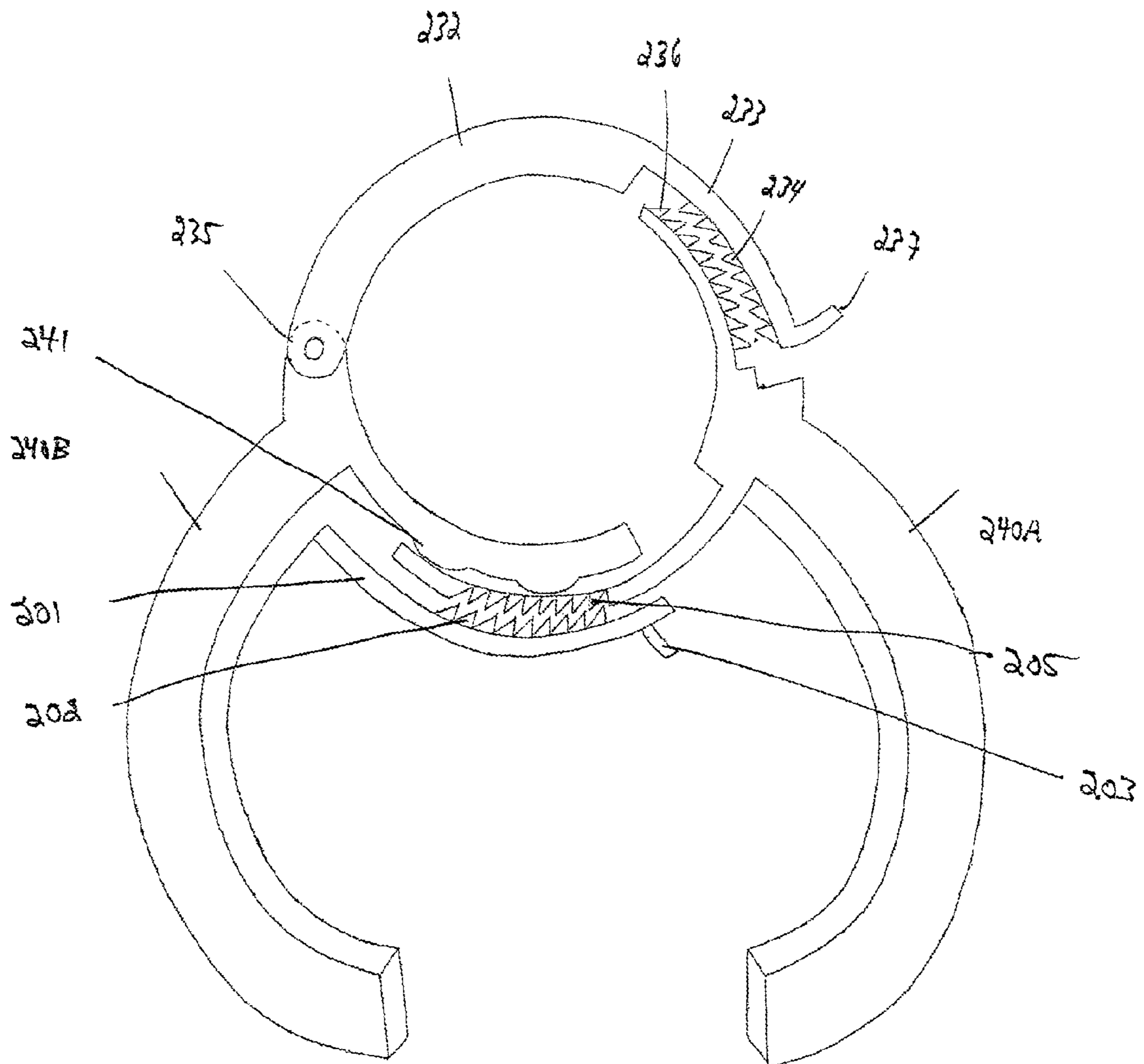

Figure 39

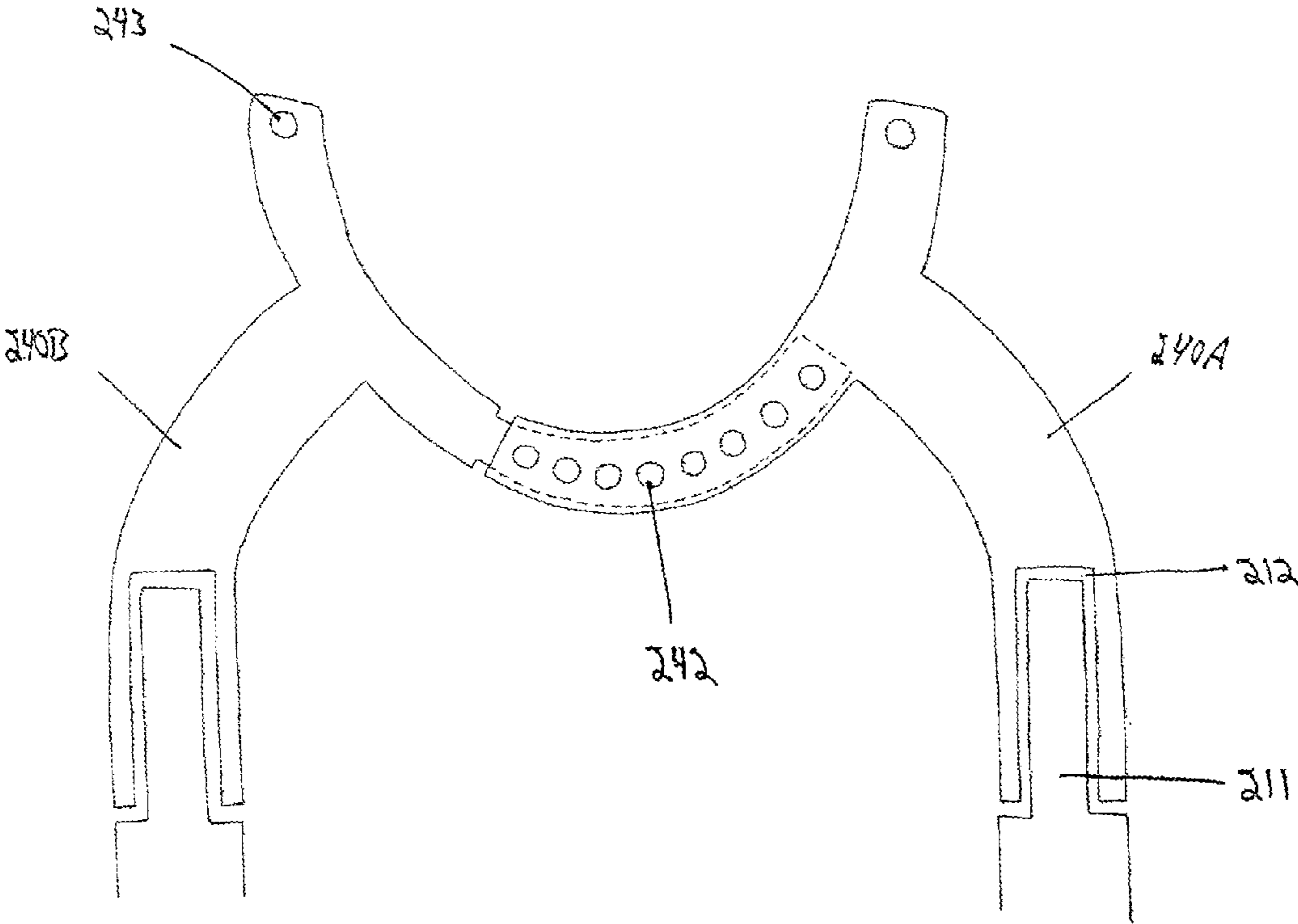

Figure 40

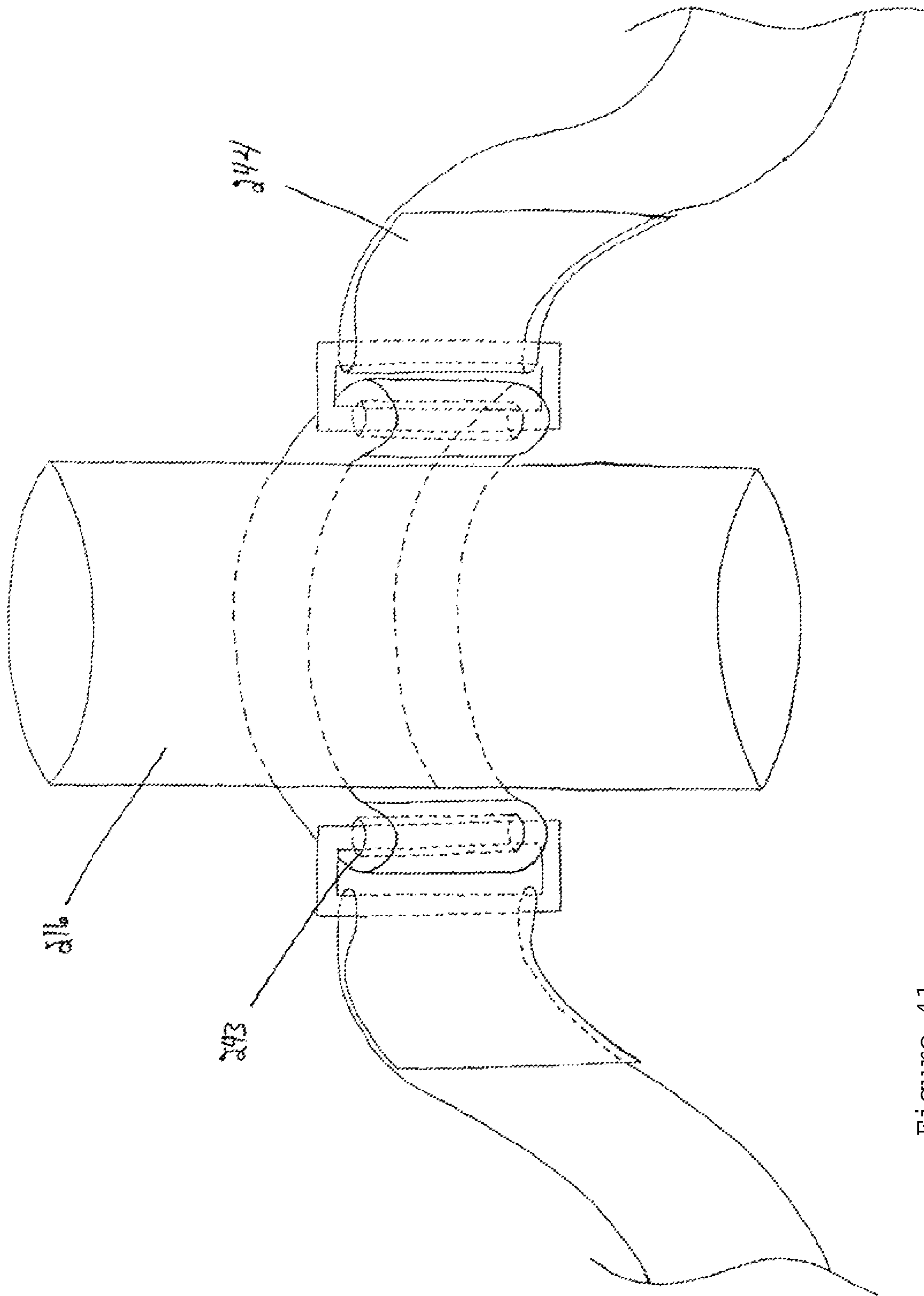

Figure 41

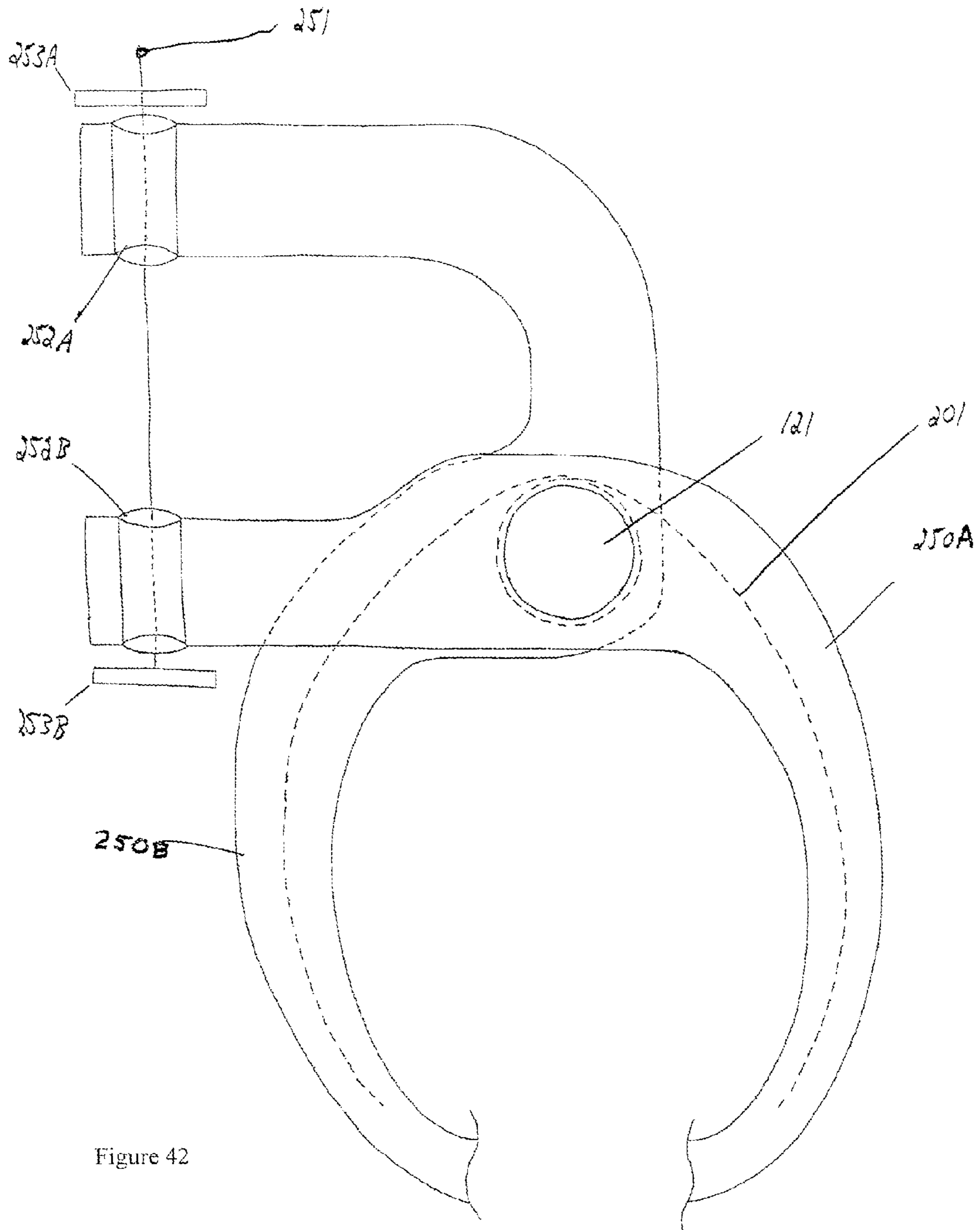

Figure 42

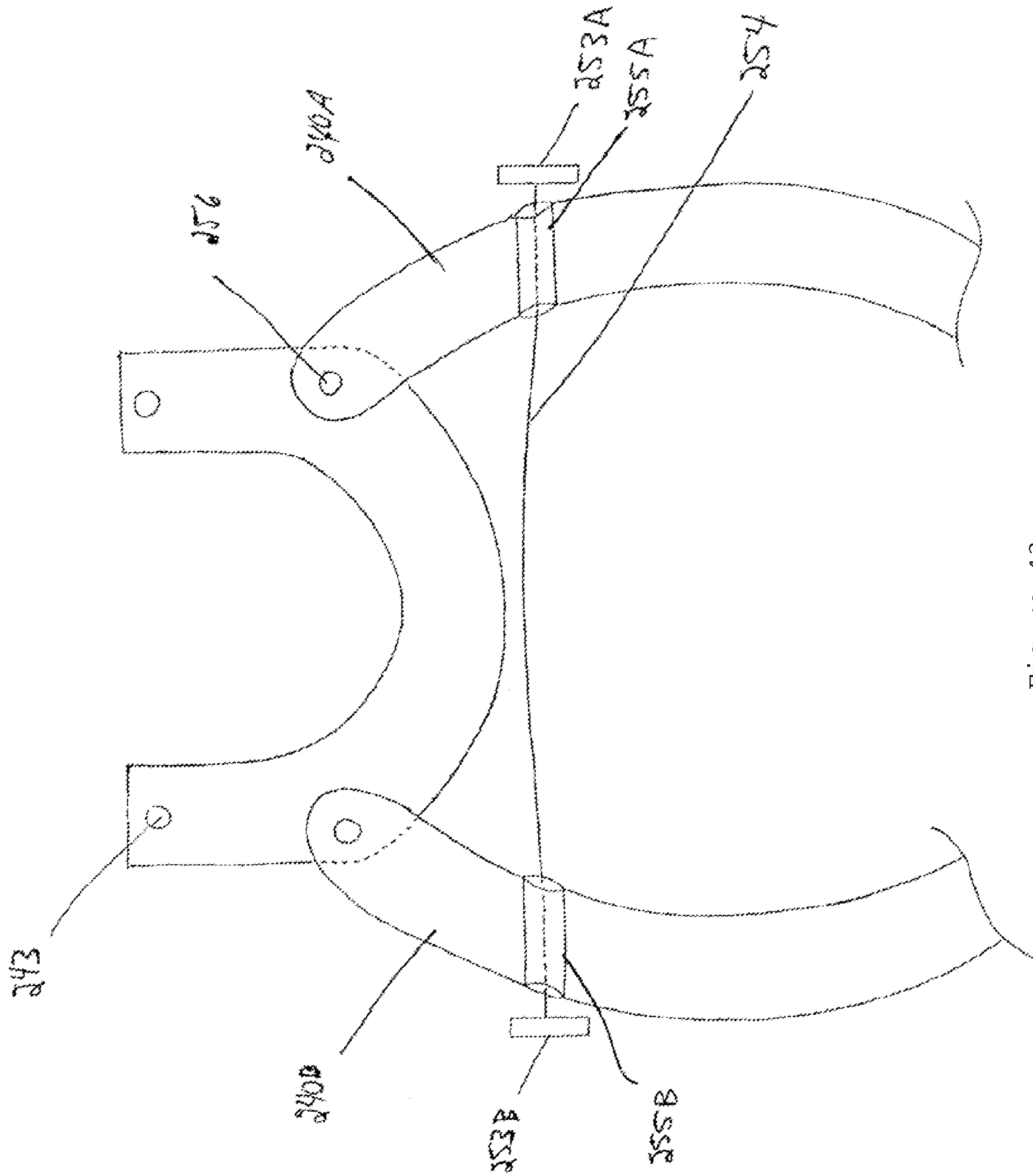

Figure 43



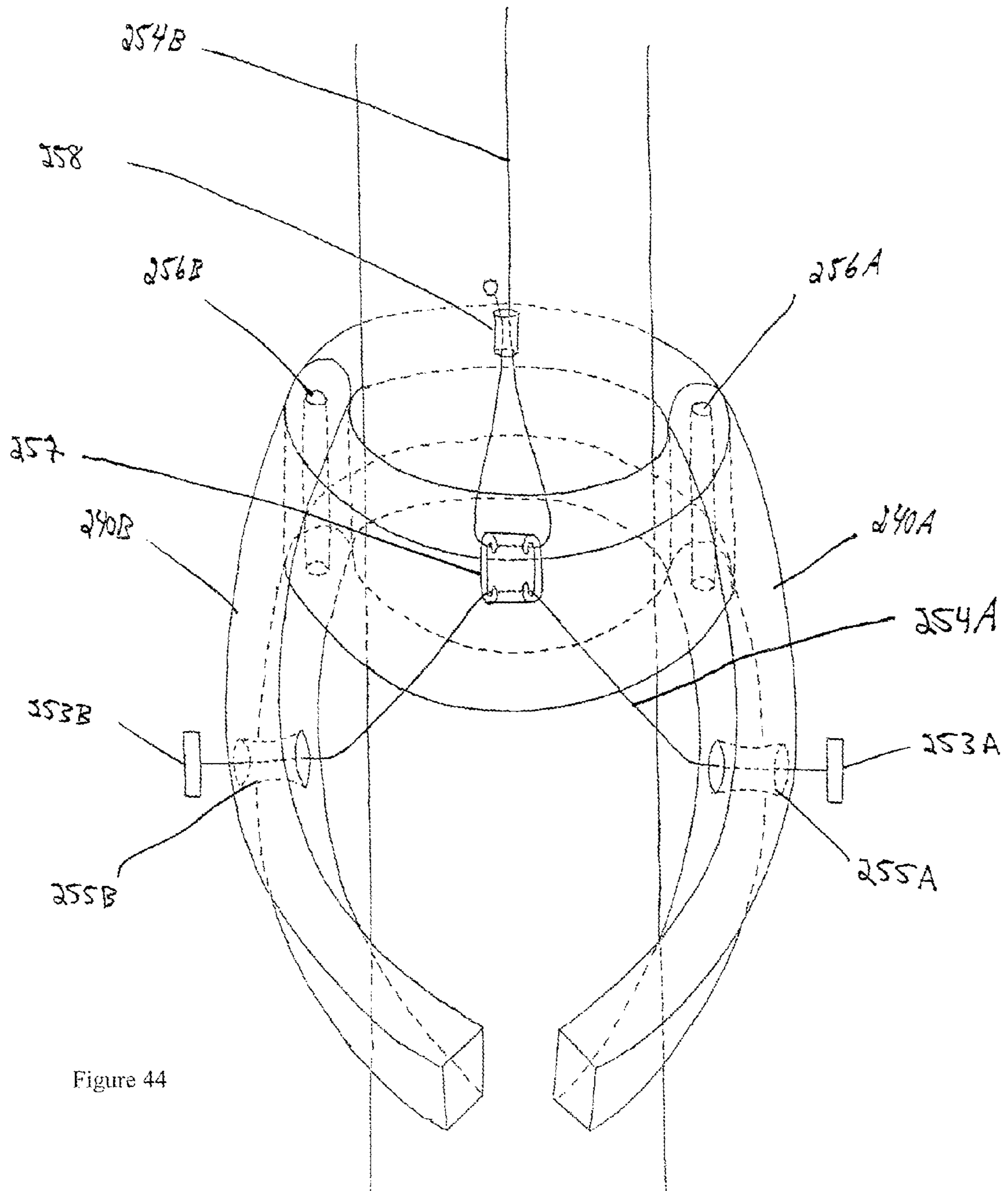

Figure 44

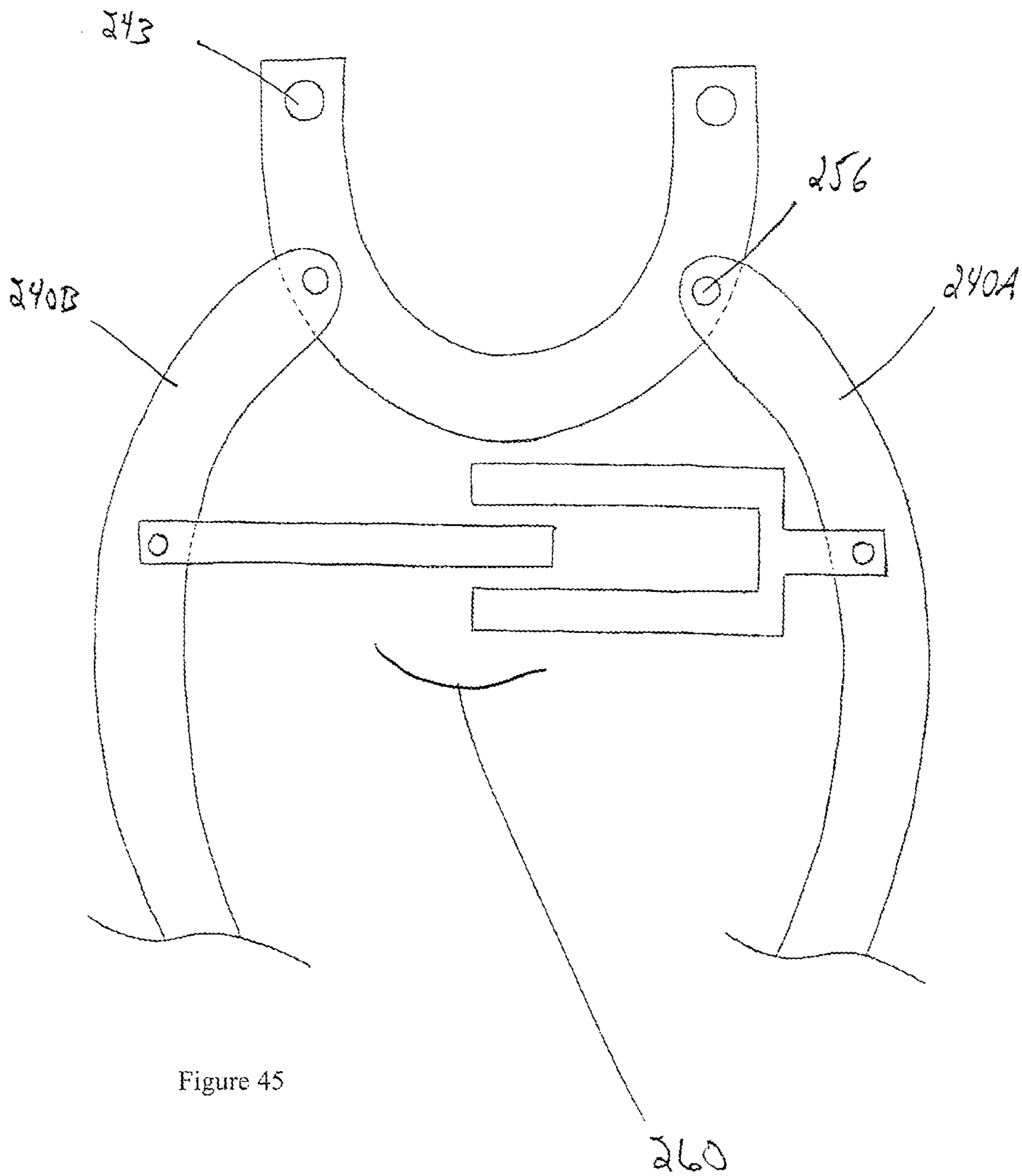

Figure 45

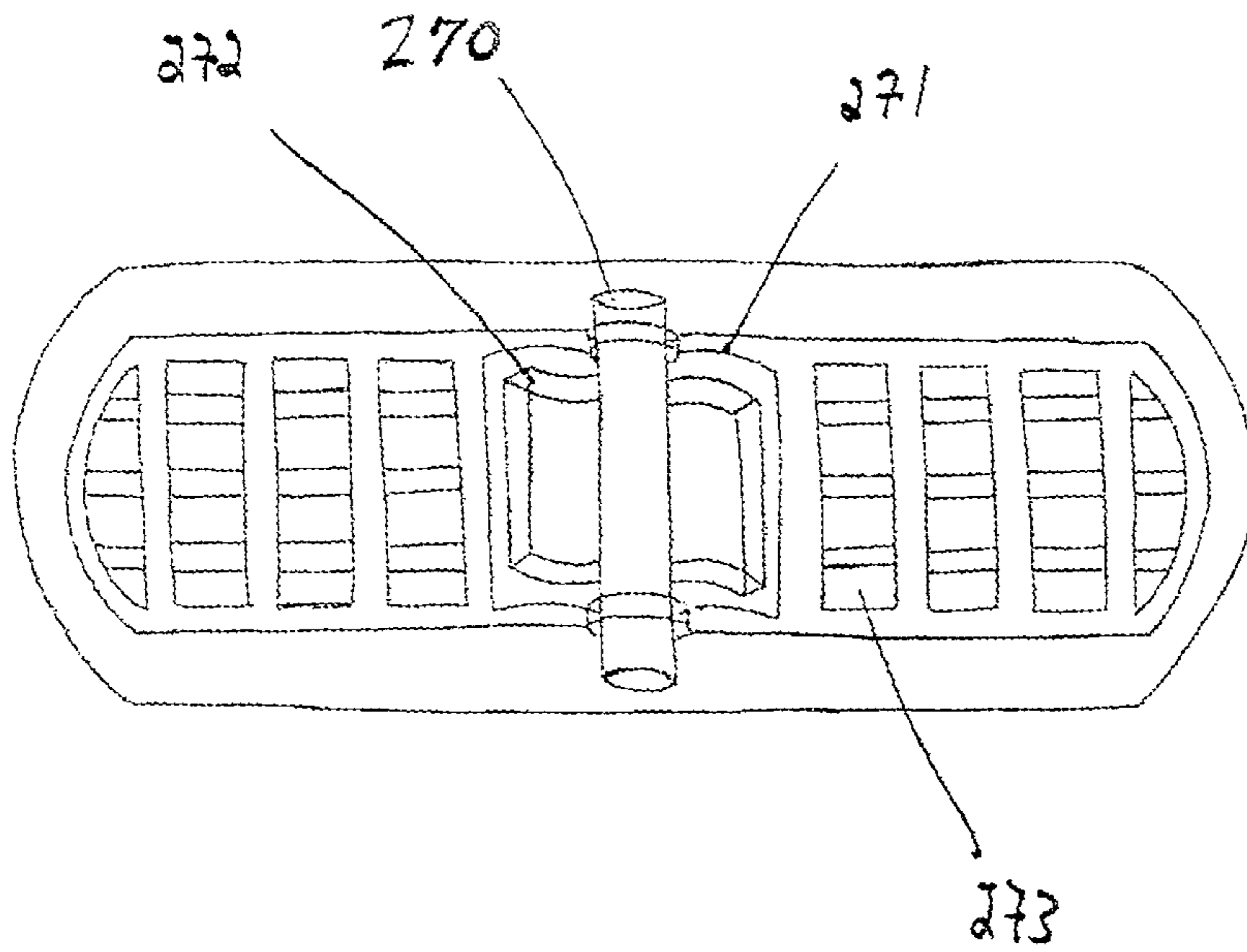

Figure 46A

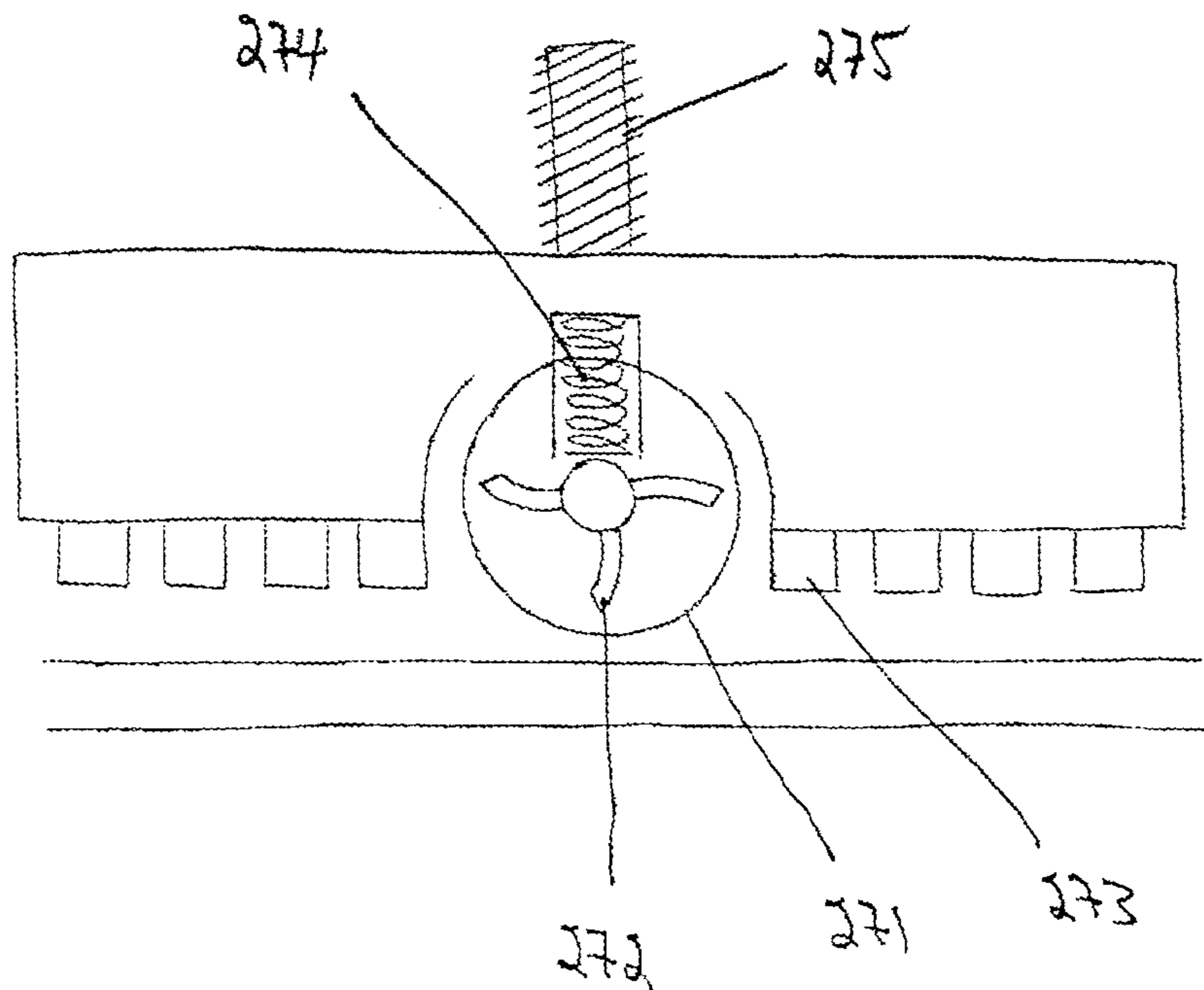

Figure 46B

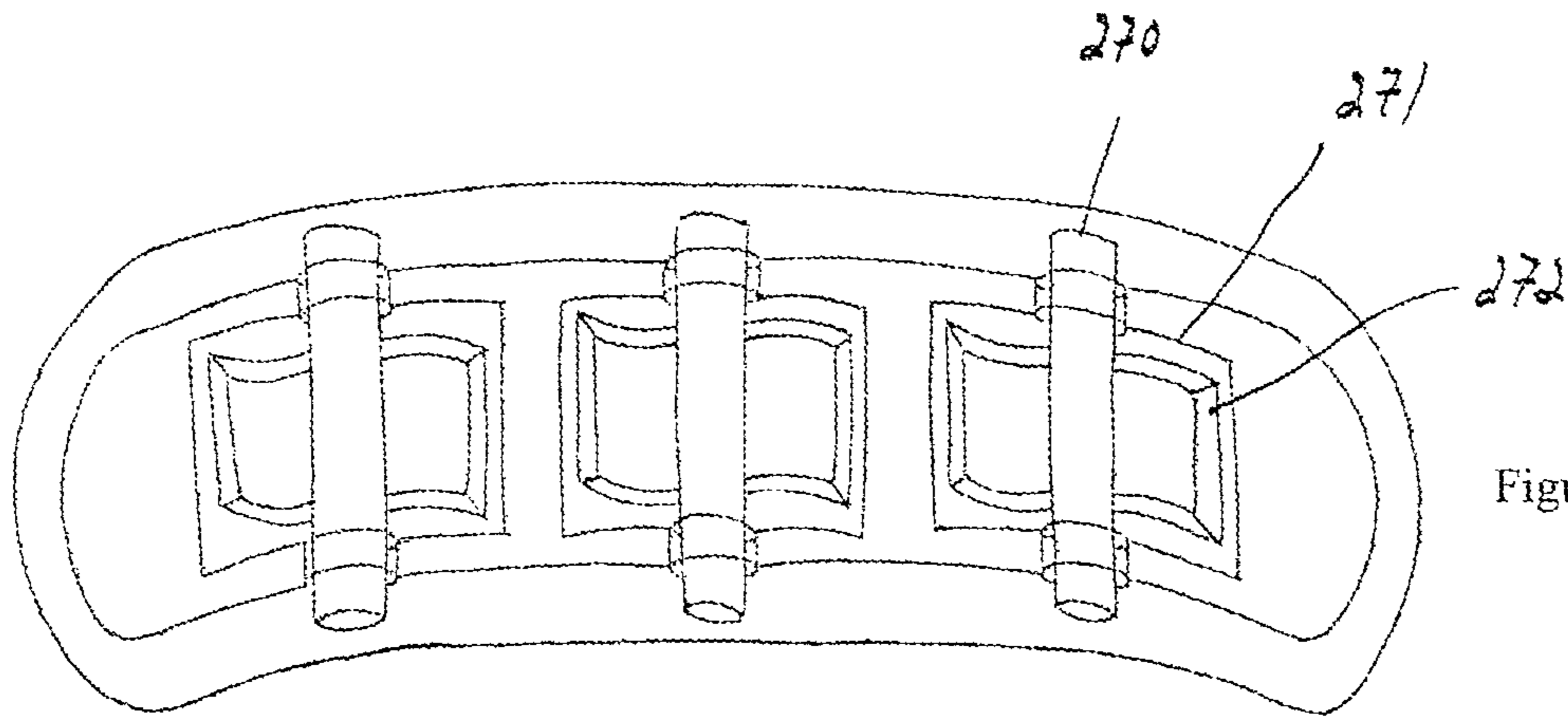

Figure 47A

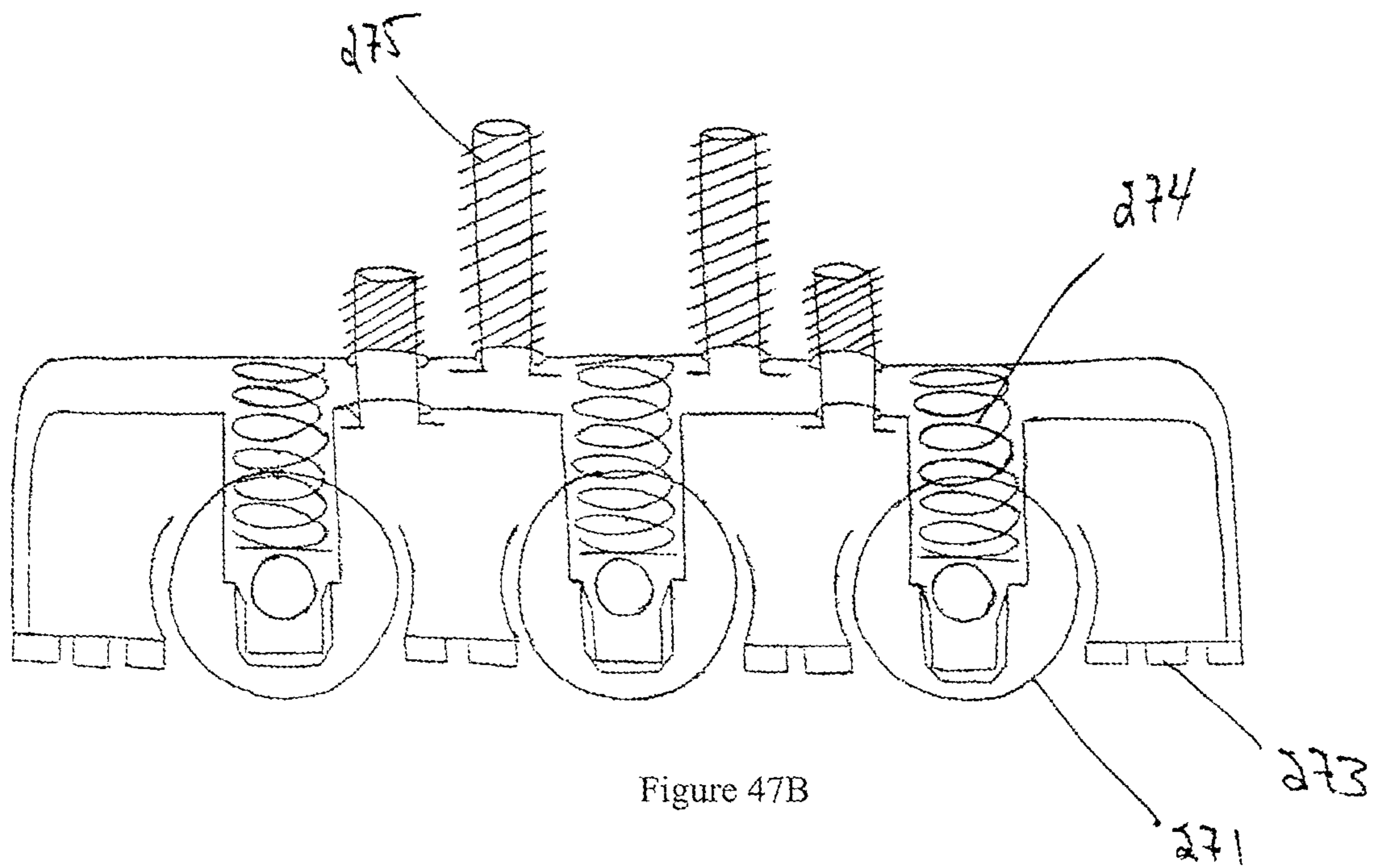

Figure 47B

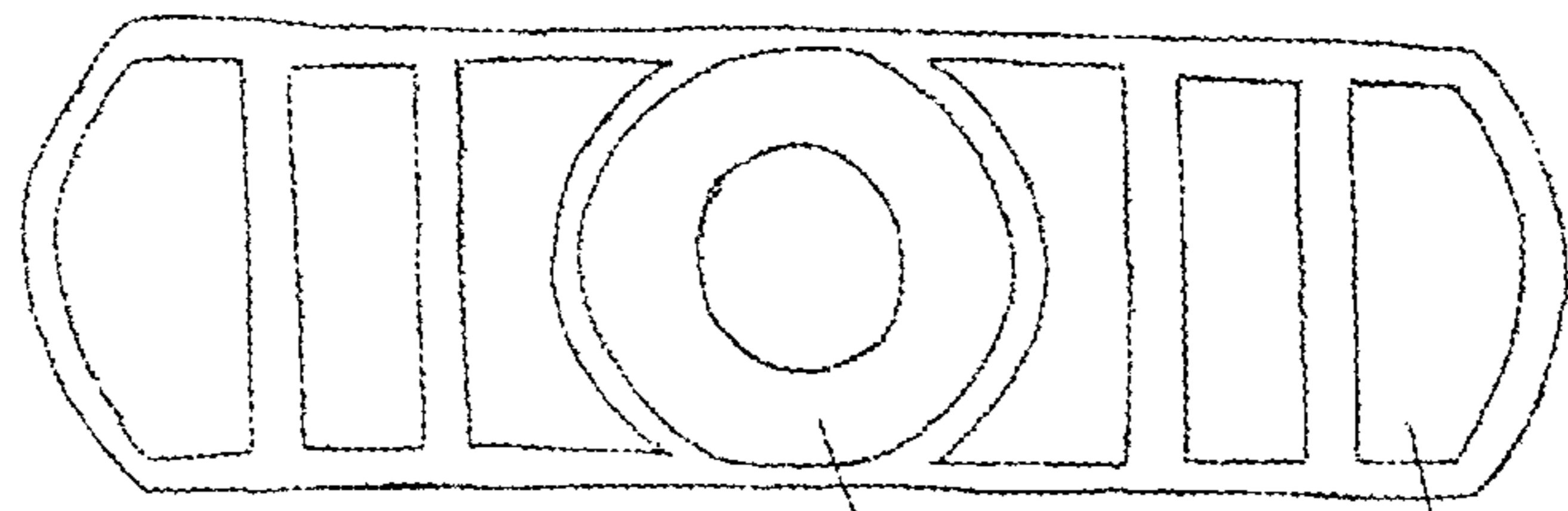

Figure 48A

276

273

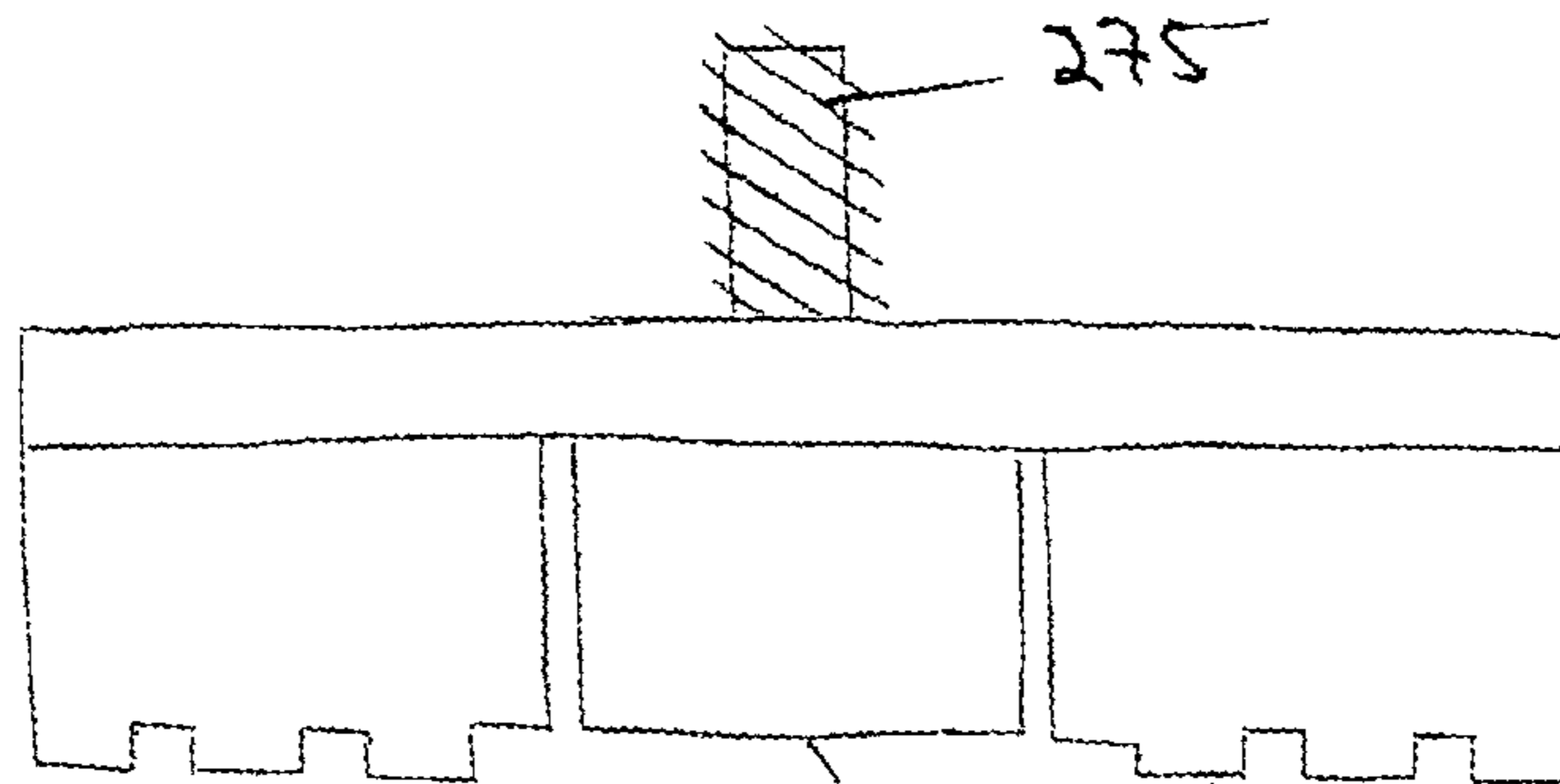

Figure 48B

276

273

275

## PORTABLE AND ATTACHABLE BICYCLE TRAINER

### PRIORITY CLAIM

This application claims priority to and incorporates entirely by reference U.S. Provisional Patent Application Ser. No. 61/354,676 filed on Jun. 14, 2010, and incorporated by reference in its entirety herein. This application claims priority to and incorporates entirely by reference U.S. Pat. No. 7,766,798, filed on Sep. 8, 2008, and entitled "Bicycle Trainer with Variable Resistance to Pedaling." This application further claims priority to and incorporates entirely by reference U.S. Pat. No. 7,955,228 filed on Nov. 13, 2008, and entitled "Magnetic Bicycle Trainer." This application further claims priority to and incorporates entirely by reference U.S. patent application Ser. No. 12/725,654 filed on Mar. 17, 2010, and entitled "Modular Tire with Variable Tread Surfaces."

### FIELD OF INVENTION

The invention relates to the field of bicycles and devices that attach to bicycles to adjust the resistance to pedaling and to provide a mechanism to enhance physical fitness training capabilities of the bicycle.

### BRIEF SUMMARY OF THE INVENTION

The invention is an improvement to bicycle trainers. In the prior art, individuals desiring to exercise with a bicycle have two options: (i) a stationary bicycle installed in a gym or a home or (ii) a portable trainer to which the individual attaches a standard bicycle. Both of these options require the user to exercise in one location, usually inside. A need exists in the area of bicycle training for equipment that allows an individual to use a specialized training regimen while riding a bicycle outside along a standard travel surface (i.e., a road, a track, a trail, and the like). Currently, an individual using a standard bicycle for exercise can adjust the intensity of the workout by riding the bicycle along planned routes of varying elevations, changing gears on the bicycle to require more intense pedaling, or both. A useful improvement to this kind of training would include equipment that gives the rider more options to vary the intensity of the pedaling required to continue. Along these lines, the rider needs bicycle accessories that adjust the resistance of tire revolution at the option of the rider and without being dependent upon the elevation of the travel path. Additionally, the bicycle training accessories could, at the option of the rider, be used to enhance a workout on a standard stationary bicycle trainer. The invention is set forth in the drawings herein as summarized below:

The invention encompasses a removable attachment for installing on a bicycle with the goal of altering the resistance to either front tire or back tire revolution. In this way, the bicycle includes enhanced physical training capabilities allowing the rider to use a bicycle on a standard trainer frame or as a regular bicycle for riding in the usual manner. In one embodiment, the attachment includes a resistance support connected to a bicycle and supporting a resistance device that engages a bicycle wheel or bicycle tire for altering the resistance to tire revolution. In this exemplary embodiment, the apparatus includes a resistance support attached to the bicycle proximate a bicycle tire along with a resistance device removably attached to the resistance support. In one embodiment, the resistance device defines a slot, and the resistance support projects through the slot to position the resistance device against the bicycle wheel or the bicycle tire.

In a different example, the invention includes the resistance support defining a groove or slot and the resistance device attached to the slot.

The resistance devices disclosed herein are interchangeable among themselves and attach to interchangeable resistance support devices. The resistance support devices may be positioned for associating with either the front tire or the back tire and may engage numerous points on the bicycle including but not limited to the seatstay, the down tube, the seat tube, and the like.

### BRIEF DESCRIPTION OF THE FIGURES

FIG. 1 is a perspective view of a rear tire of a standard bicycle elevated on a bicycle trainer and having a resistance support extending from the seat stay connected to the rear forks.

FIG. 2 shows an embodiment of the resistance support on a bicycle frame and allows for the bicycle to be ridden outside (i.e., not on a standard bicycle trainer).

FIG. 3 is a perspective view of an exemplary bracketing system for holding a resistance support on the seat stay.

FIG. 4 is a top view of an exemplary resistance support having openings for attaching a resistance device.

FIG. 5 is a side view of one kind of resistance device sliding onto a resistance support.

FIG. 6 is a cross section view of a resistance device according to the disclosure herein.

FIG. 7 is a perspective view of a resistance device including a battery housing for use with an electromagnet according to the disclosure herein.

FIG. 8 is a perspective view of a resistance device having adjustable tension according to the disclosure herein.

FIG. 9 is a cross section view of a resistance device utilizing magnetic resistance according to the disclosure herein.

FIG. 10 shows a cross section of a resistance device utilized with a layered tire embodiment according to the invention herein.

FIG. 11 shows an exemplary embodiment of a layered tire for use with the resistance device disclosed herein.

FIG. 12 shows a different view of the resistance device according to FIG. 11.

FIG. 13 is a cross section view of a layered embodiment of a tire used with a resistance device according to this disclosure.

FIG. 14 shows a resistance device according to this invention and uses the bicycle wheel rim as a source of ferromagnetism.

FIG. 15 shows cross section view of a magnetic clip that attaches to the rim of a bicycle wheel and allows for use of a magnetic resistance device according to this invention.

FIG. 16 shows a magnetic clip that crosses over the spokes of a standard bicycle wheel and allows for using a magnetic resistance device according to this invention.

FIG. 17A shows a second segment of a magnetic clip that crosses over the spokes of a standard bicycle wheel according to the invention described herein.

FIG. 17B shows a third segment of a magnetic clip for use with the segments shown in FIGS. 16 and 17A.

FIG. 18 shows a cross section of the magnetic clip segments of FIGS. 16, 17A, and 17B.

FIG. 19 shows a side view of a resistance device attached to the seat stay and incorporating sufficient magnetic force for use with a ferromagnetic disc brake.

FIG. 20 shows a cross section view of the resistance device according to FIG. 19.

3

FIG. 21 shows a cross section of a resistance device according to FIG. 19 with the addition of a separate ferromagnetic resistance disc according to the disclosure herein.

FIG. 22 shows a cross section of a disc brake embodiment of the invention with magnets integrated into the brake pad assembly.

FIG. 23 is a perspective view of the magnets of FIG. 22.

FIG. 24 shows a perspective view of a resistance device connected to the chainstay of a bicycle according to this invention.

FIG. 25 shows a side view of the embodiment of FIG. 24.

FIG. 25A shows a tire hub fitting around a ferromagnetic axle on a bicycle wheel.

FIG. 25B shows a cross section of the embodiment of FIG. 25A.

FIG. 25C shows an embodiment of the axle of FIG. 25 with the axle as a solid cylinder.

FIG. 25D shows an embodiment of the axle of FIG. 25 with the axle as a grooved structure for use with electromagnetic embodiments of the disclosure herein.

FIG. 26 shows a resistance device according to FIG. 5 with resistance rollers incorporated therein.

FIG. 27 shows a perspective view of the resistance device according to FIG. 26.

FIG. 28 shows a resistance device according to this disclosure in which the rollers are positioned via squeezable mechanical structure to adjust tension.

FIG. 29 shows a cross section of the resistance device according to FIG. 28 with the addition of a spring for tension adjustment.

FIG. 30A-30D show various rollers for use with the resistance device of FIG. 26.

FIG. 31 shows a cross section of the resistance device of FIG. 29 with tension adjusting handles attached to a tension coil.

FIG. 32 shows a cross section of the resistance device of FIG. 29 with tension adjusting handles attached to a ratcheting mechanism.

FIG. 33 shows a cross section of the resistance device of FIG. 32 defining an opening for attaching to the resistance support of FIG. 1.

FIG. 34 shows an embodiment of this invention with a slotted resistance support attached to a seat tube on a bicycle.

FIG. 35 shows a top view of a resistance device having a connector for sliding into the slot of the resistance support of FIG. 34.

FIG. 36 shows an embodiment of a resistance device for connecting to the resistance support of FIG. 34 and incorporating a bifurcated tension cable for tightening rollers against a tire rim.

FIG. 37 shows a resistance device in the form of parallel rollers on opposite sides of a seat post.

FIG. 38 shows a cross section of a roller oriented resistance device adjusted by a ratcheting mechanism.

FIG. 39 shows the ratcheting mechanism with positioning nodes thereon.

FIG. 40 shows a resistance device according to FIG. 36 with holes for receiving pins to adjust tension on the rollers.

FIG. 41 is an embodiment of a resistance device according to FIG. 5 with attachment straps for attaching to the bicycle.

FIG. 42 shows a resistance device as disclosed herein with tension cables for adjusting the pressure on a bicycle tire.

FIG. 43 shows a resistance device as disclosed herein with tension cables for adjusting the pressure on a bicycle tire.

FIG. 44 shows a resistance device as disclosed herein with tension cables for adjusting the pressure on a bicycle tire.

4

FIG. 45 shows a resistance device for attaching to a seat post and incorporating an electromagnetic resistance assembly according to the disclosure herein.

FIGS. 46A and 46B show a resistance assembly utilizing rollers embedded in brake pads.

FIGS. 47A and 47B shows a resistance assembly utilizing multiple rollers embedded in the same brake pad.

FIGS. 48A and 48B show a brake pad with an electromagnet embedded therein for use with a ferromagnetic assembly on a bicycle tire.

#### DETAILED DESCRIPTION

This detailed description includes certain terms that are related to bicycle parts (or "bicycle anatomy") that are commonly known in the art of bicycles. Terms related to bicycles and bicycle trainers are given their broadest ordinary meaning. A bicycle according to this invention encompasses a two wheeled machine with handle bars, a seat, pedals, a chain, and other normal parts of the everyday bicycle. The invention disclosed herein may be used with a bicycle trainer frame that allows a user to attach his or her own bicycle to the frame to simulate riding conditions. The invention also encompasses embodiments that are attached to a bicycle that is ridden in a normal way, such as a road bike or trail bike.

A bicycle typically consists of two wheels having respective rims for attaching respective bicycle tires. The bicycle tires have a road surface for engaging the road and side walls that extend when inflated. A bicycle in accordance with this invention includes commonly known standard parts (i.e., a seat, handle bars, brakes, break levers, gears, a chain, spokes, and the like). Other parts of a bicycle are useful for attaching a resistance support there to and are known by terms that are commonly known by those skilled in the art of bicycles. In this regard, this specification includes terms for bicycle parts that should be given their broadest meaning in line with common usage in the art of bicycles. For instance, a bicycle includes a seat post holding the saddle or seat. The seat post is connected to a downwardly extending seat tube connected proximate the pedals. A seat stay extends toward the rear tire from the seat post toward the rear axle. On the front end of the bicycle, a stem connects the handlebars to a top tube that extends from the handlebars to the seat post. A head tube connects the front axle to the top tube, and a down tube extends from the head tube toward the pedals. All of these bicycle anatomy terms are listed for example only, and these terms are intended to have their broadest meaning in terms of actual position and use in a bicycle structure.

The term bicycle trainer is used in its broadest sense to include all kinds of devices that individuals use to simulate bicycle riding conditions with a bicycle. A bicycle trainer often has a trainer frame that is stable on a support surface and lifts a rear tire of a bicycle off the floor while allowing the bicycle pedals to rotate the tire. A bicycle trainer often has a mechanism that adjusts the resistance to bicycle pedaling (i.e., a cylinder or roller against which a rear tire presses).

FIG. 1 shows a standard bicycle having a bicycle frame 101 that can engage a bicycle training stand 100 to elevate the bicycle for training in a stationary setting. The bicycle includes standard parts in the form of a rear tire 102 on a rear tire axle 103 connected to a chain-stay 105. In today's training equipment, the training stand 100 includes a cylinder engaging the rear tire of the bicycle to vary resistance to pedaling. The invention herein, however, changes that standard set up to attach resistance enhancing accessories to the bicycle itself. The predominant tool for enhancing resistance in FIG. 1 is the resistance support 104. The resistance support

## 5

is adapted to receive resistance enhancing equipment, or a resistance device, thereon at the option of the user without interfering with standard bicycle operation in any way. In this embodiment, the resistance device **120** would slide over the resistance support **104**. The resistance devices **120** are described in more detail in turn below.

FIG. **2** shows an embodiment of the resistance support **104** on a bicycle frame **101** and allows for the bicycle to be ridden outside (i.e., not on a standard bicycle trainer).

FIG. **3** shows a bracket set up for attaching the resistance support **104** to the bicycle frame, in particular the seat stay **110**. The bracket consists of a top bracket **108** and a bottom bracket **109**, each having a respective front face (**112**, **114**) and rear face (**111**, **113**). The bracket portions connect to one another around the seat stays **110**.

FIG. **4** shows the resistance support **104** having attachment openings **115** that could receive a pin or other latch for attaching a resistance device **120** to the prong-shaped resistance support **104**.

FIG. **5** shows one embodiment of a resistance device **120** that fits about the resistance support **104** attached to the bicycle frame. The resistance support **104** holds the resistance device **120** in a particular orientation relative to the rear tire **102** of the bicycle. This particular resistance device **120**, which does not limit the invention in any way is only shown as an example, is especially useful for providing resistance to pedaling in conjunction with a magnetic sleeve attached to the rear tire. The resistance device, therefore, would provide a second magnetic force that engages a magnetic sleeve on the rear tire to adjust the resistance to pedaling.

FIG. **6** shows more details regarding a resistance device **120** of FIG. **5**, including an outer housing and a slot **121** for sliding over the resistance support **104**. A magnetic plate **124** would provide the above described second magnetic field for use with a sleeve on the rear tire having a first magnetic field. See prior noted U.S. Pat. No. 7,955,228, incorporated herein in its entirety, for more details regarding the magnetic sleeve. As seen in prior embodiments set forth in the '228 patent by this same inventor, a bicycle tire may be composed of a slot for placing a removable strip with a magnetic inner portion that fits within the slot. In a preferred embodiment, the strip fitting within the tire slot is further characterized by a rubber coating intended to engage the road during use. The magnetic plate **124** of the resistance device **120** is held in place by a magnetic plate bracket (H-shaped) **126** that fits within hollowed portions of the resistance device for accurate plate positioning around the tire. An adjustable screw **127** controls proximity of the magnetic plate with the magnetic sleeve. The adjustable screw **127** has interior threading to receive a counter screw **128** holding the H-shaped bracket in place. Channels **125** in the outer housing of the resistance device **120** receive the outer legs of the H-shaped bracket **126**.

FIG. **7** is an overview of another resistance device **120** that fits on the resistance support **104** and includes a battery housing **130** for use with electromagnetic trainers discussed in the above noted prior U.S. Pat. No. 7,955,228.

FIG. **8** is an overall combination of FIGS. **5-7** and shows a resistance device **120** that slides over the resistance support **104** and provides for magnetic portions **124** to surround a bicycle tire.

FIG. **9** is an embodiment of a new trainer used for riding on a road or track outside and incorporating the resistance modulating devices **104** described above. The embodiment of FIG. **9** is particularly suited for use with slotted tire embodiments set forth in prior patent applications (e.g., Ser. No. 12/725,654 incorporated herein by reference) and described above. In the drawing of FIG. **9**, a magnetic plate **124** is in electromagnetic

## 6

communication with a magnetic portion of a slotted tire receiving a magnetic sleeve around the tire. The sleeve has magnetic side panels **136A, B** for electromagnetically engaging the magnetic plate **124** and a rubberized section **135** that the rider can use on the road. In a different embodiment utilizing the same magnetic plates **124**, the magnetic portion of the bicycle tire may be incorporated into the tire itself (**102**). In this regard, the cross section of the tire **102** would show a layer of magnetic material (e.g., a magnetic film) surrounded by adjacent layers of rubber for contacting the inner tube **107** on one side and the road on the opposite side.

FIG. **10** shows the combination of FIGS. **5-9** but the tire is circumferentially layered so that the magnetic portion of the tire is an inner layer **138**. The tire has an outer rubber layer **135** for engaging the road.

FIGS. **11/12/13** shows yet another embodiment for providing a magnetic insert **139** to the tire as shown in cross section in FIG. **13**. See also prior U.S. Pat. No. 7,955,228 incorporated entirely by reference herein. Reference **139** shows the magnetic layer between inner tube **107** and the tire **102**. The magnetic layer **139** includes tabs **140** that fit within openings in the tire **141**. The cross section is taken with the tabs extending through the openings **141**.

FIG. **14** shows a way of using the bicycle tire rim **106** as a source of ferromagnetism. By making the rim **106** of a lightweight ferromagnetic material, the trainer body can be positioned adjacent the rim with the magnetic plate in sufficient proximity thereto for variable resistance to pedaling. The rim **106** would be positioned in proximity to the resistance device **120**. The magnetic plate **124**, the H-shaped magnetic plate bracket **126**, adjustable screw **127**, and counter screw **128** are all the same as described above.

FIG. **15** shows an accessory for making a standard rim of a bicycle a ferromagnetic rim for use as shown in FIG. **14** above. The device of FIG. **15** incorporates a magnetic clip **145** that fits on a standard bicycle rim so that the clip electromagnetically engages the resistance device **120** via a magnetic plate **124**. The resistance device is held in place on the resistance support **104** as described above.

FIG. **16** shows a new kind of ferromagnetic clip **145** that crosses over the spokes of a bicycle wheel. The ferromagnetic clip of FIG. **16** is modular in that separate pieces engage the bicycle rim to avoid crossing over the associated spokes of the bicycle wheel. The magnetic clip of this invention has an abbreviated side **145A** that fits over the rim up to the point of bracing against a first spoke extending from the rim to the bicycle tire axle. An associated section of the magnetic clip **145**, referred to herein as a mating side **145B**, continues around the first spoke until it extends up against a second spoke. The abbreviated sides **145A** and mating sides **145B** connect around the circumference of the bicycle tire rim, avoiding spokes accordingly. To accomplish this connection among abbreviated and mating sides (shown in detail in FIGS. **17** and **18**), each portion has a section that extends approximately 270 degrees around a bicycle rim and then an extension that fits across the rim until it abuts a spoke. Then the next section has an extension fits on the other side of the spoke over the rim to match the first extension. The pattern continues until the entire rim is covered by a magnetic clip **145**. FIG. **18** shows the cross section of the result.

FIGS. **19-23** fit a magnetic resistance device **153** over a disk brake **150** which can be made of a ferromagnetic material. The clip **153** attaches via a support arm **152** that is connected to a seat stay **110**. A seat stay attachment **151** holds the magnetic resistance device in position. This embodiment allows a U-shaped magnet **153** to surround the disc brake, providing a means of electromagnetically varying resistance



to pedaling. The magnetic resistance device **153** is positioned so that it does not hinder operation of the gears and derailleur **154**. FIG. **20** is an expanded rear view of the device shown in FIG. **19**.

FIG. **21** shows that the magnetic resistance device may be positioned via a pivot point **156**. For those bicycles using a disc that is not ferromagnetic, this embodiment of the invention incorporates a second disc **160** onto the axle. The magnet **153** is positioned to be magnetically coupled to the second disc **160**.

FIG. **22** shows an embodiment of FIGS. **19-21** that allows for ferromagnetic components to optionally adjust the resistance to pedaling and further provide for disc brakes to fit within the same assembly. The figure shows brake pads **155A**, **155B** (dotted) fitting through an opening in respective vertically oriented magnets **157A**, **157B**. Again, the point is to provide magnets in proximity to currently used bicycle structures, such as a disc brake to control resistance to pedaling. FIG. **23** is a perspective view of the magnets of FIG. **22**.

FIG. **24** shows that a disk other than a disk brake may be made available on a standard bicycle to accomplish the goals of this invention in providing accessories that can be made available to add and subtract resistance to pedaling. FIG. **24** shows adding an electromagnetic pedal disk **160** to the cross bar **166** of a bicycle pedal assembly (pedals **164**, crankarm **163**). A magnet **153** is adjacent the disk **160**. The magnet **153** is held in place in a way that is similar to above-described embodiments. In FIG. **24**, the magnet **153** is held in place with a chainstay attachment **162**. As used above, the magnet **153** is held in position by a support arm **152** and may further include a pivot point **156**. FIG. **25** shows a side view of the pedal embodiment of FIG. **24**.

FIG. **25A** shows a tire hub fitting around an axle on a bicycle tire. The axle is ferromagnetic, and the hub has a magnetic cylinder lining the interior opening such that the axle interchangeably extends through the hub. Resistance to pedaling is determined by the extent of the magnetic field between the two components. An electromagnet embodiment could reasonably follow from this design.

FIG. **25 B** is a cross section of FIG. **25A**.

FIG. **25C** shows that the axle can be a solid cylinder.

FIG. **25D** shows that the axle could be grooved for an electromagnetic embodiment such that conductors extend within the grooves.

FIG. **26** shows yet another attachment that will be made available to the resistance support **104**. In the embodiment of FIG. **26**, the resistance is varied by rollers **171A** and **171B** that will engage the rim of an associated bicycle. The figures show similar structural points as noted in prior embodiments.

FIG. **27** shows the rollers of FIG. **26** having a set resistance to pedaling as shown by the resistance to the rollers that brace against the tire rims.

FIG. **28** uses rollers in a resistance device as in FIGS. **26** and **27**, but in these embodiments, the resistance to pedaling is set by the elasticity of the materials that make the pliable frame **182** of the device. In FIG. **28**, the resistance device incorporates squeezable top tabs **181A**, **B** for positioning the rollers **171A**, **B** over the tire rim.

FIG. **29** adds a spring mechanism **184** to the unit of FIG. **27**. Various embodiments of the rollers that can be used in this invention are set forth in FIGS. **30A**, **30B**, and **30C**. The rollers may include paddles that rotate within resistance fluid to vary the resistance to pedaling (FIG. **30A**). The rollers may engage both the rim and the tire body FIG. **30B**, or may have an angled shape to engage particularly shaped tire rims. FIG. **30C**.

FIGS. **31-33** illustrate an embodiment of the invention in which the resistance support **104** has a substantially round cross section. The resistance device is in the form of a clamp that fits over a tire rim and has a round opening **121** for fitting over the resistance support **104**. A spring **201** inside the clamp sets the resistance of rollers **171A**, **B**. FIGS. **32** and **33** use ratchets to allow for adjusting the tension of the rollers against the tire rim. Spring **206** keeps the teeth of the ratchet assembly engaged. FIG. **33** shows a more compact design with the ratchet assembly located within the interior of the clamp **200A**. The clamp **200A** is further characterized by an adjustable height controller **211**, **212** set by screw **213** to allow for different sized tires fitting between the resistance support **104** and the rim of the bicycle tire.

FIG. **34** shows yet another position for attaching a resistance device that can be used on a standard bicycle. The resistance support is a bracket **220** that fits around a seat post **216**. The bracket defines a slot **225** in which a resistance device fits.

FIG. **35** shows a cross section of FIG. **34** with a resistance device incorporating rollers **171A**, **B**. The cross bar **222** of the resistance device fits down into the slot **225** of the bracket **220**. Pliable frame **221** sets the tension by bracing the rollers against the rim. The frame is more readily installed by using thumb rests **223**.

FIG. **36** shows a resistance device with a cross bar **222** that can fit within the bracket **220**. A sliding pressure cap **230** engages a threading on the pliable frame to squeeze legs of the pliable frame together and force the rollers against the tire rim.

FIG. **37** shows a seat post attachment in the form of arms on both sides of the seat post for attaching tension rollers to brace against the tire.

FIGS. **38** and **39** show a seat post attachment with rollers **171A**, **B** that provide resistance to pedaling by adding resistance to rear tire revolution. The attachment to the seat post is controlled by ratcheting mechanism **232-237** and the amount of tension the rollers emit onto the back tire of a bicycle is controlled by a second ratcheting mechanism **201-205**. FIG. **39** shows nodes **241** providing positioning bumps to force the ratchet teeth **202** and **205** together. FIG. **39** further shows a more suitable shape for mountain bike tires.

FIG. **40** uses the same concepts of FIGS. **38** and **39** but instead of ratchets, holes with associated pins would accomplish the same function to hold the device to the seat post.

FIG. **41** shows a strap **244** connecting the resistance device to the seat post.

FIGS. **42-44** show various embodiments of using cables that the rider can manipulate from the handle bars to engage and disengage the tension of rollers or magnetic plates similar to FIG. **9** on the resistance devices with the tire, side wall, rim, or disc brake. FIG. **42** is a rear view of the device attached to a resistance device **104** via the opening **121**. The cable control mechanism would be positioned off the underside of the rider's seat. The cable goes up along seat post to handle bars where the user can clamp the rollers on or off or the position of the plates in relation the tire. FIG. **43** shows part of a seat post installation shown in more detail in FIG. **44**. FIG. **43** shows the cable in a relaxed, non-engaged state while FIG. **44** incorporates a C-Clamp **257** to serve as the intermediate control between a handle bar connector cable **254B** and the roller control cable **254A**.

FIG. **45** shows a seat post attachment in which an electromagnet assembly **260** draws in the arms **240A**, **B**. Circuitry controlled through the handle bar attachments (not shown) move the electromagnets in and out to adjust the position of associated rollers or other tension forming devices.

FIG. 46 shows rollers in brake pads that can be used to control resistance to pedaling in various fashions. In the embodiment of FIG. 46, while the user is riding the bicycle, a roller 271 is adjacent the tire. When the user engages the brakes from the handle bars, a spring 274 allows the rollers to retract so that the brakes engage the rim. A different embodiment shows that the brakes themselves could include rollers with internal paddles 272 in the rollers 271.

FIG. 47 shows multiple rollers on a single brake pad 273.

FIG. 48 shows the use of electromagnetic 276 in the brake pad 273 for magnetic resistance with the rim of a tire.

The following Parts List is useful for additional explanation of the anatomy of a bicycle and the structural connections between a bicycle, a resistance support, and a resistance device according to this invention

bicycle stand 100  
 bicycle frame 101  
 rear tire 102  
 rear tire axle 103  
 resistance support 104  
 chainstay 105  
 Brackets: 111-114  
 Seat Stays: 110  
 Disc of the disc brake 150  
 Seat Stay attachment 151  
 Support arm 152  
 U-shaped magnet (specifically electromagnet) surrounding the disc 153  
 Derailleur 154  
 Pivot point 156  
 Resistance device 153  
 Pedal stem (Crankarm) 163  
 Pedals 164  
 Pedal cross bar 166  
 Horizontal Frame bar Chainring 165  
 Chainstay attachment 162  
 Support arm 152  
 Pivot Point 156  
 Ferromagnetic Pedal Disc 160  
 Roller having an Axle 170A, B  
 Roller having an Axle 171A, B  
 U-shaped Bracket 180A, B  
 Handles 200A, B  
 Ratchet clamp having Clamp Handles for squeezing inwardly 200A, B  
 Ratchet 201 having Inter-digitating 202 teeth and a ratchet handle 203  
 Post 204 having corresponding teeth 205 with a post support 207  
 Spring 206  
 Roller can pivot about pivot point 210 A, B to engage the rim properly  
 Seat Post 215  
 Seat Tube 216

Top Tube 217

Resistance Bracket 220

Slot for fitting the cross bar of a resistance device therein 225

Attachment holes 226 for receiving bolts for water bottle holder and the like

Resistance bracket 220 shown in cross section with securing screw 227

Pliable frame 221 for the resistance device (resistance depends on the flexibility of the frame and the inherent resistance of the roller itself)

Pressure Cap 230 engages a threading on the cross bar

Resistance Bracket 231

Arms 232

Curved Clamp handles 240 A, B that fit around a mountain bike tire

Positioning Bumps 241 provide pressure of one set of teeth onto the other

Cable 251 through openings in the bracket 252A, B

Resistance arms for holding the rollers 250A, B

Cable Stop 253 A, B

Cable 254

C-clamp 257

Rollers in the brake pad 273

spring 274

The invention claimed is:

1. An apparatus for altering the resistance to tire revolution on a bicycle, the apparatus comprising:

a resistance support attached in a fixed position to the bicycle proximate a bicycle tire, said resistance support defining a slot;

a resistance device slidably mounted and removably attached to the slot in said resistance support and engaging said bicycle tire to alter resistance to tire revolution;

wherein said resistance device comprises at least one roller engaging a rim connected to said bicycle tire.

2. An apparatus according to claim 1, wherein said resistance support is attached to a seat tube on the bicycle.

3. An apparatus according to claim 1, wherein said roller is adjustable such that said roller exerts a variable pressure against said rim.

4. An apparatus according to claim 1, wherein said roller is adjusted by an adjustment mechanism, wherein said adjustment mechanism is selected from the group consisting of a cable, a screw, a spring, and a clamp.

5. An apparatus according to claim 4, wherein said adjustment mechanism comprises a cable extending from said adjustment mechanism to a handle bar on said bicycle.

6. An apparatus according to claim 1, wherein said resistance device comprises at least one roller engaging a side wall of said bicycle tire.

7. An apparatus according to claim 1, wherein said resistance support is attached to a down tube on said bicycle.

\* \* \* \* \*