

US008964600B2

(12) **United States Patent**
Biswas et al.

(10) **Patent No.:** **US 8,964,600 B2**
(45) **Date of Patent:** ***Feb. 24, 2015**

(54) **METHODS OF FORMING VIRTUAL NETWORK OVERLAYS**

(75) Inventors: **Amitabha Biswas**, San Francisco, CA (US); **Jayakrishna Kidambi**, San Jose, CA (US); **Nilanjan Mukherjee**, Santa Clara, CA (US); **Vijoy A. Pandey**, San Jose, CA (US)

(73) Assignee: **International Business Machines Corporation**, Armonk, NY (US)

(*) Notice: Subject to any disclaimer, the term of this patent is extended or adjusted under 35 U.S.C. 154(b) by 136 days.
This patent is subject to a terminal disclaimer.

(21) Appl. No.: **13/454,840**

(22) Filed: **Apr. 24, 2012**

(65) **Prior Publication Data**
US 2013/0044631 A1 Feb. 21, 2013

Related U.S. Application Data

(63) Continuation of application No. 13/212,790, filed on Aug. 18, 2011.

(51) **Int. Cl.**
H04L 12/28 (2006.01)
H04L 12/715 (2013.01)
H04L 12/931 (2013.01)
H04L 12/46 (2006.01)
H04L 29/08 (2006.01)
G06F 9/455 (2006.01)

(52) **U.S. Cl.**
CPC **H04L 45/64** (2013.01); **H04L 49/70** (2013.01); **H04L 49/356** (2013.01); **H04L 12/4679** (2013.01); **H04L 67/2804** (2013.01); **G06F 9/45558** (2013.01); **G06F 2009/45595** (2013.01)

USPC **370/254**

(58) **Field of Classification Search**
USPC 370/360, 473, 390, 392; 709/238
See application file for complete search history.

(56) **References Cited**

U.S. PATENT DOCUMENTS

8,155,146	B1 *	4/2012	Vincent et al.	370/473
2009/0037607	A1	2/2009	Farinacci et al.	
2011/0035494	A1	2/2011	Pandey et al.	
2011/0090911	A1	4/2011	Hao et al.	
2011/0103389	A1	5/2011	Kidambi et al.	
2011/0110377	A1	5/2011	Alkhatib et al.	
2011/0119748	A1	5/2011	Edwards et al.	
2011/0310899	A1 *	12/2011	Alkhatib et al.	370/392
2011/0320821	A1 *	12/2011	Alkhatib et al.	713/176
2012/0014387	A1	1/2012	Dunbar et al.	

(Continued)

OTHER PUBLICATIONS

International Search Report and Written Opinion for counterpart application No. PCT/IB2012/053679 dated Dec. 20, 2012, 7 pages.

(Continued)

Primary Examiner — Albert T Chou

(74) *Attorney, Agent, or Firm* — Schmeiser, Olsen & Watts LLP

(57) **ABSTRACT**

Methods are provided for overlaying a virtual network on a physical network in a data center environment. An overlay system is arranged in an overlay virtual network to include an overlay agent and an overlay helper. The overlay agent is implemented in an access switch. The overlay helper is implemented in an end station that is in communication with the access switch. Overlay parameters in compliance with an in-band protocol are transmitted between the overlay agent and the overlay helper.

18 Claims, 11 Drawing Sheets

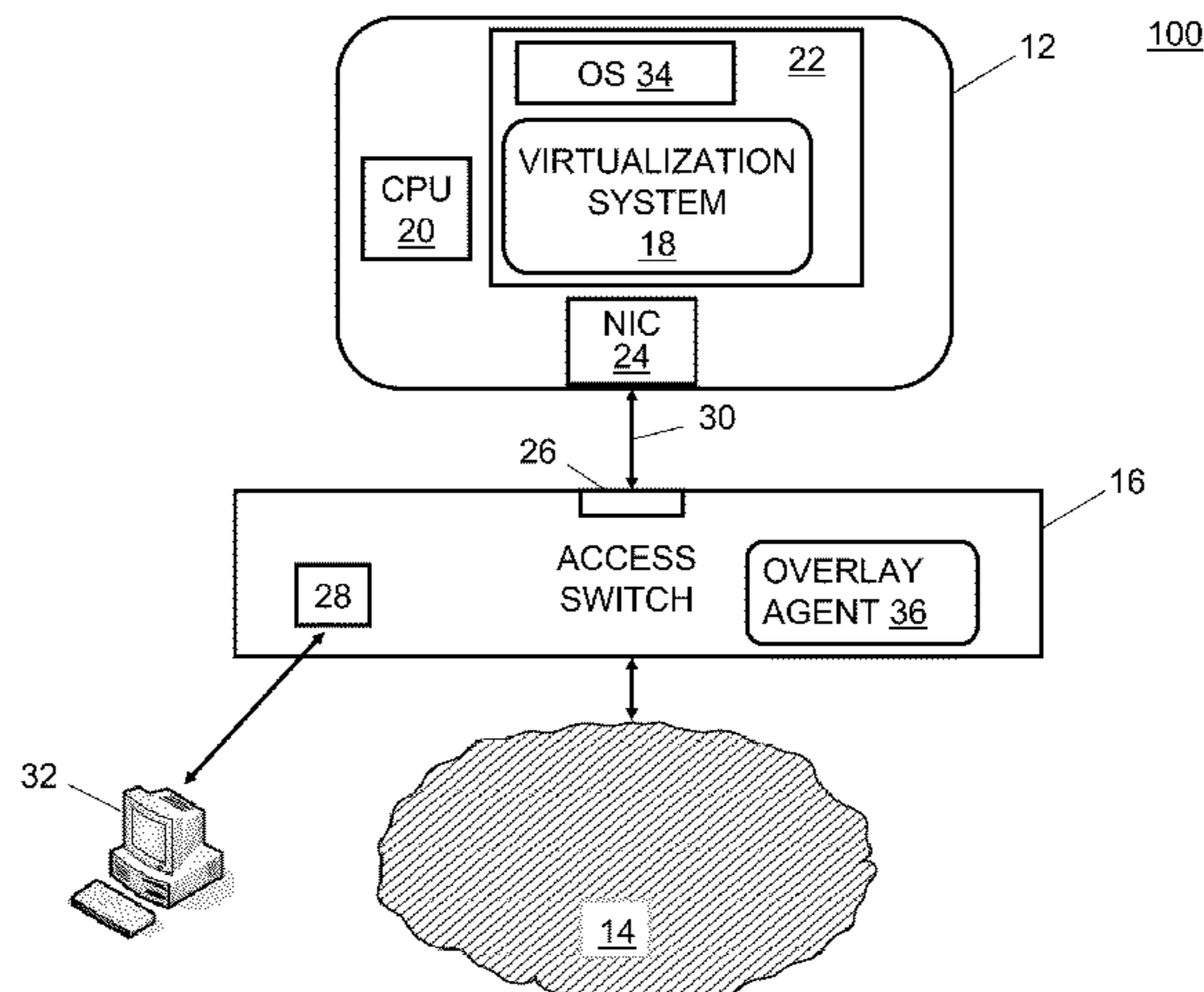

(56)

References Cited

U.S. PATENT DOCUMENTS

2012/0176934 A1 7/2012 Farinacci et al.
2012/0250682 A1* 10/2012 Vincent et al. 370/390
2013/0034094 A1* 2/2013 Cardona et al. 370/360
2013/0205042 A1* 8/2013 Cohn 709/238

OTHER PUBLICATIONS

English translation for Chinese application No. CN101326771A
dated Dec. 17, 2008, 1 page.

Yu, Wei; "Providing Efficient Virtual Cooperation Services for Large Scale Networks"; Proceedings-2004; 12th IEEE International Conference on Networks; Dec. 1, 2004; pp. 160-164.

Non-Final Office Action in related U.S. Appl. No. 13/212,790, mailed on Jul. 9, 2013; 11 pages.

Final Office Action in related U.S. Appl. No. 13/212,790, mailed on Oct. 25, 2014; 10 pages.

Notice of Allowance in related U.S. Appl. No. 13/212,790, mailed on Jun. 5, 2014; 5 pages.

* cited by examiner

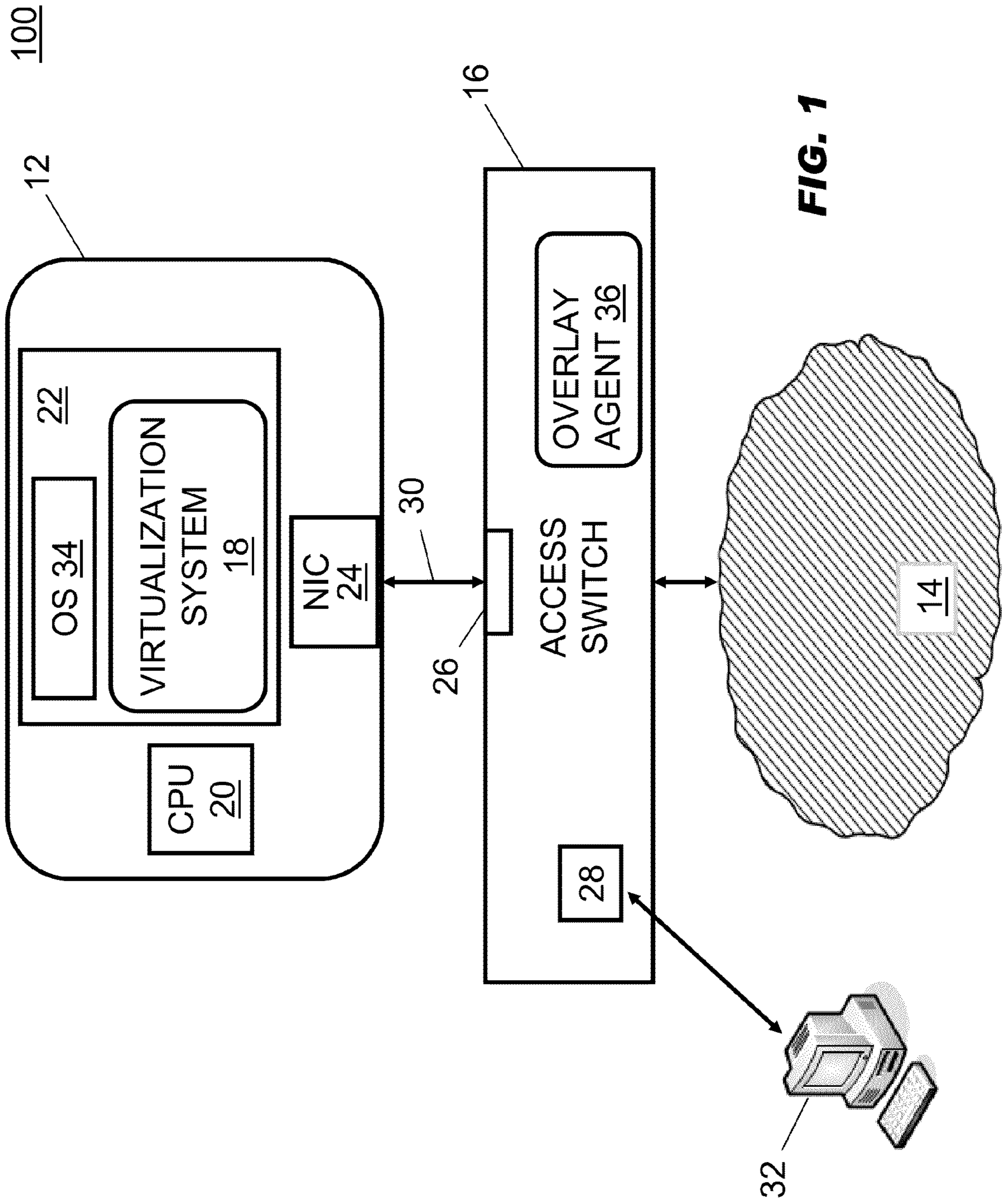

FIG. 1

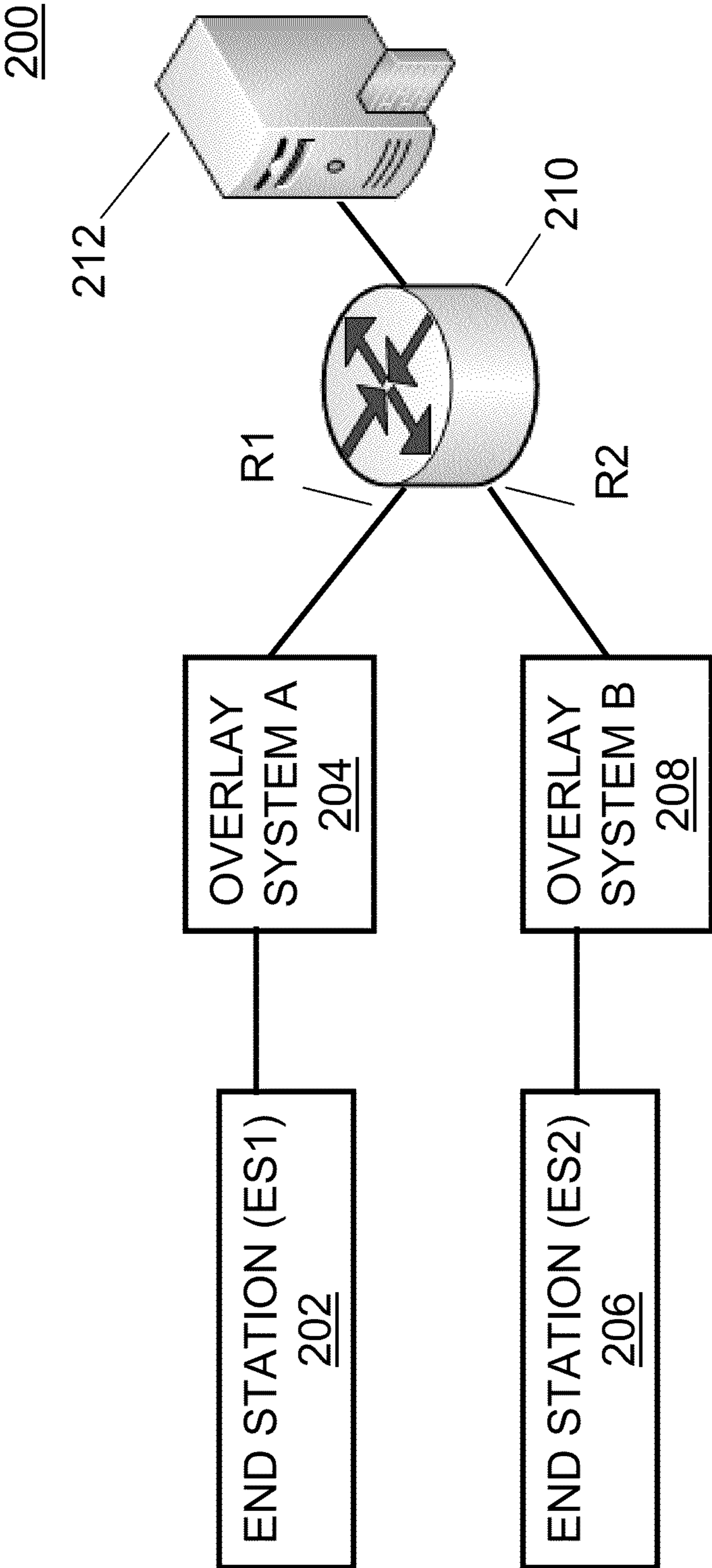

FIG. 2

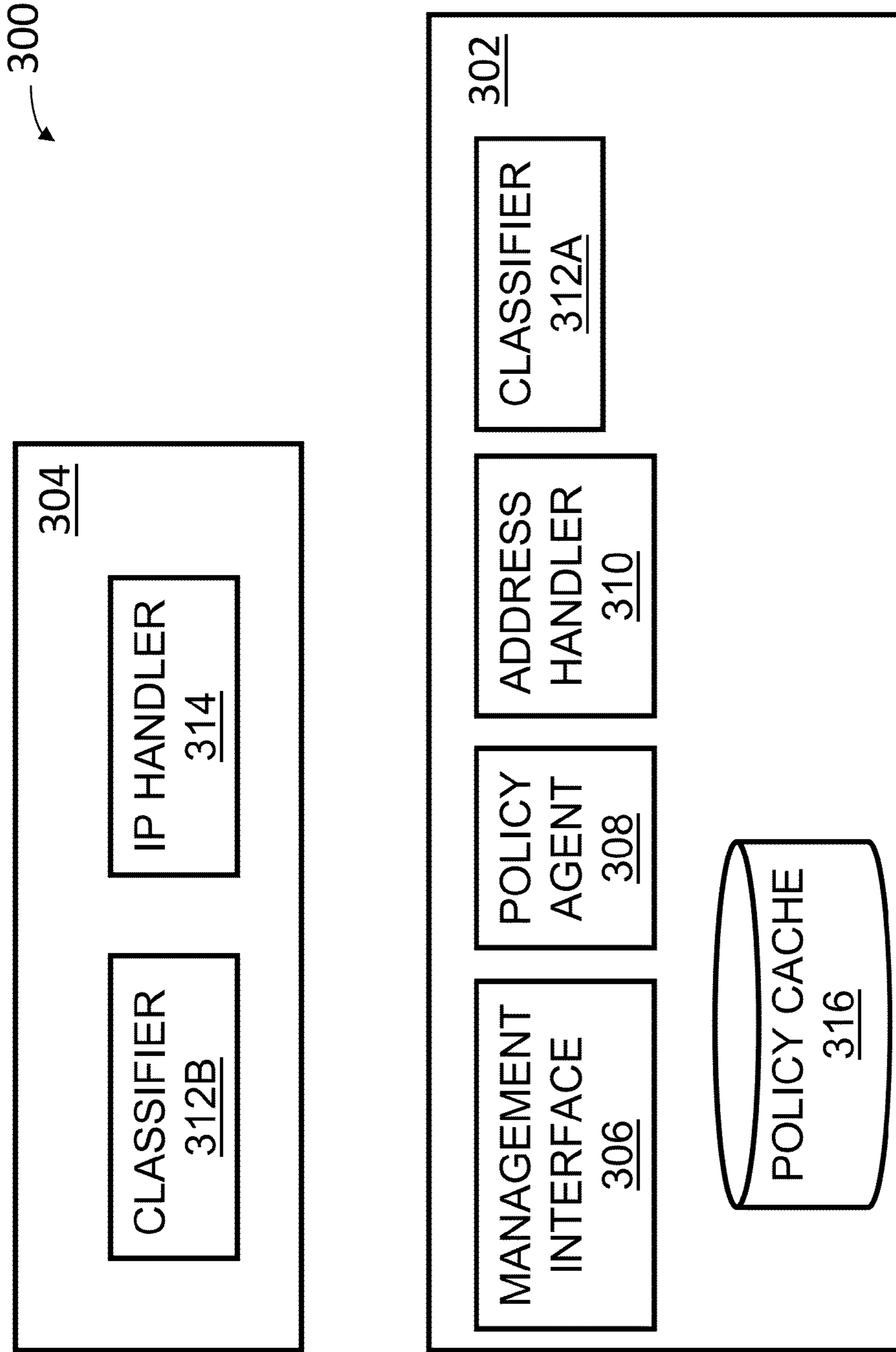

FIG. 3

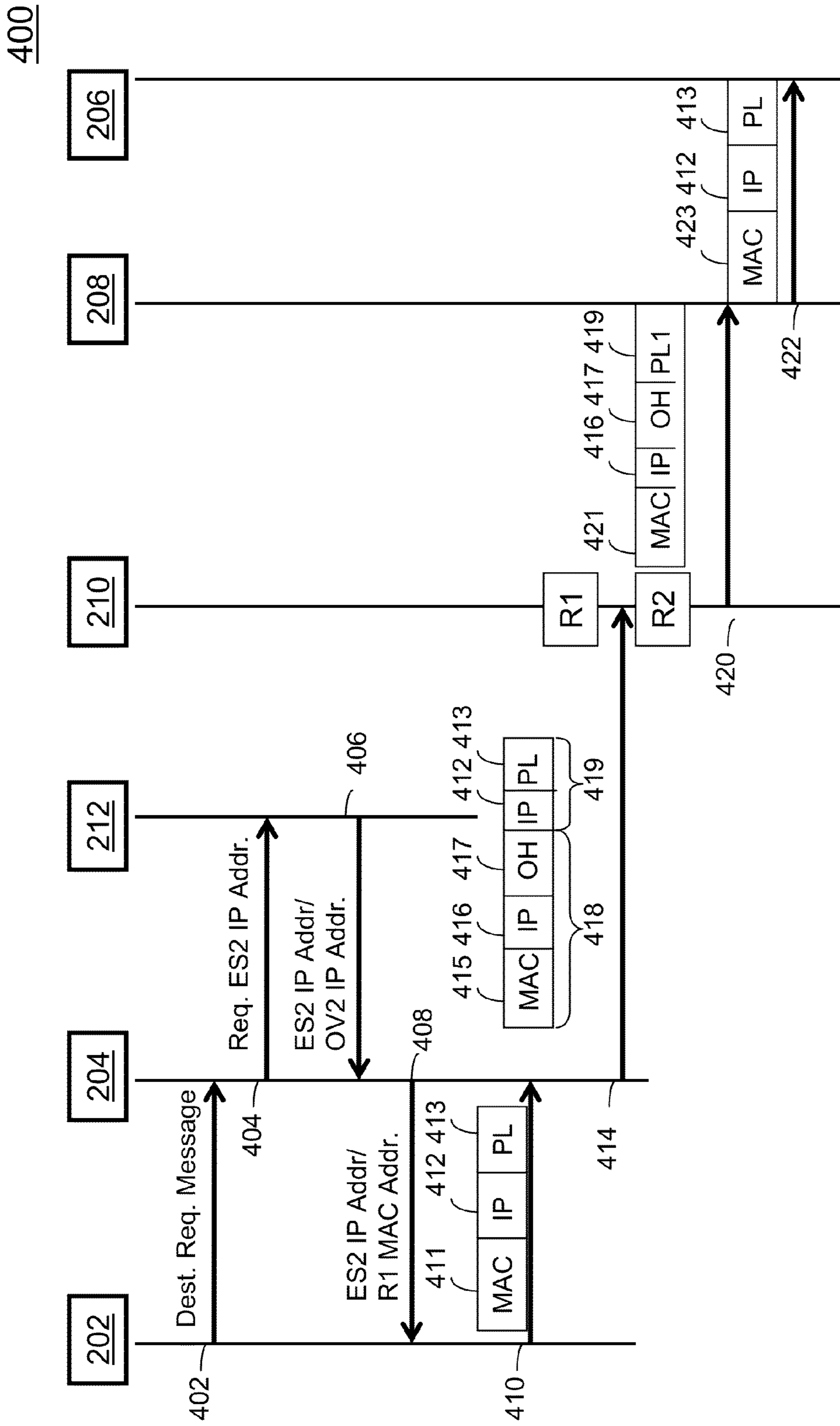

FIG. 4

500

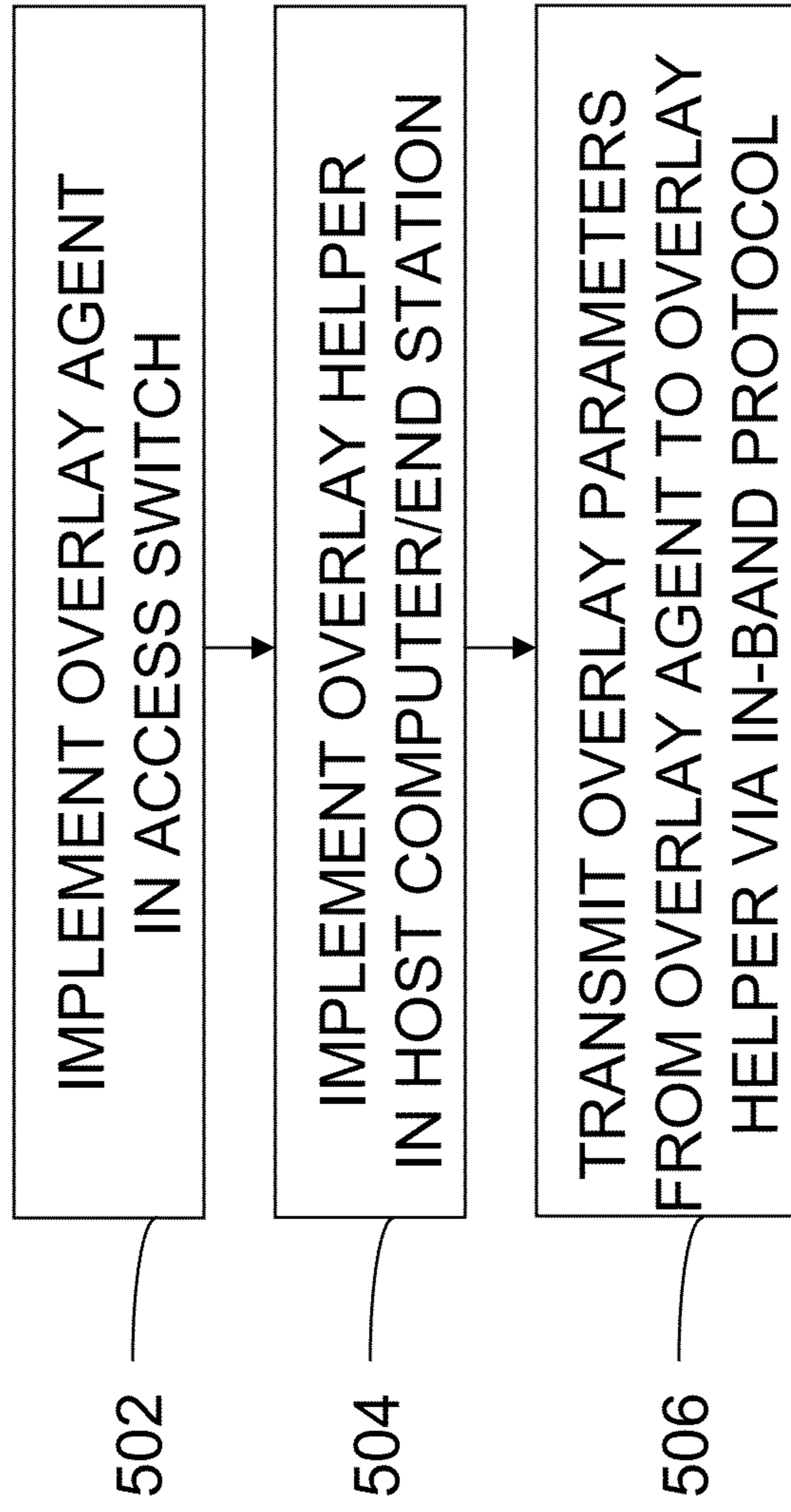

FIG. 5

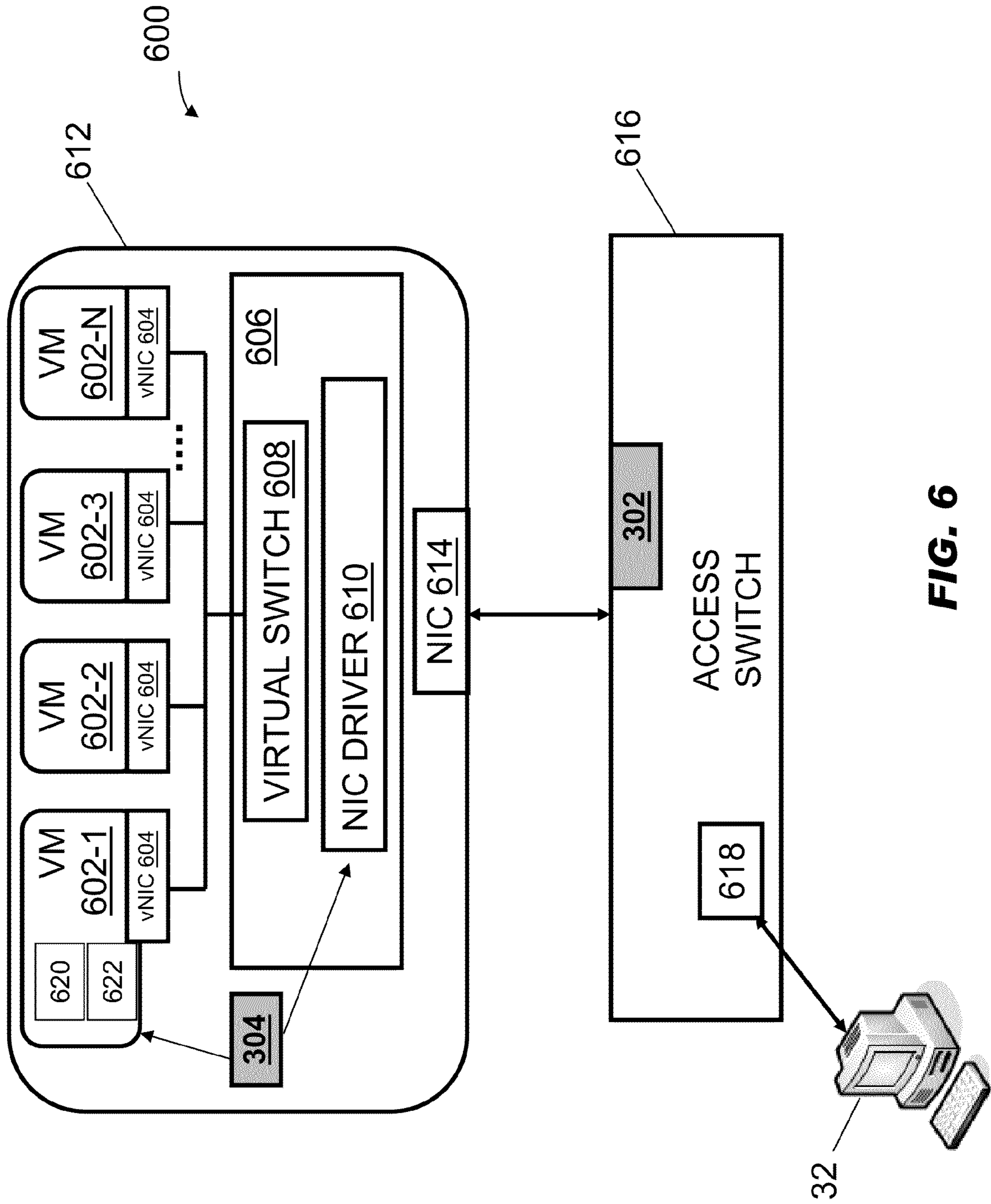

FIG. 6

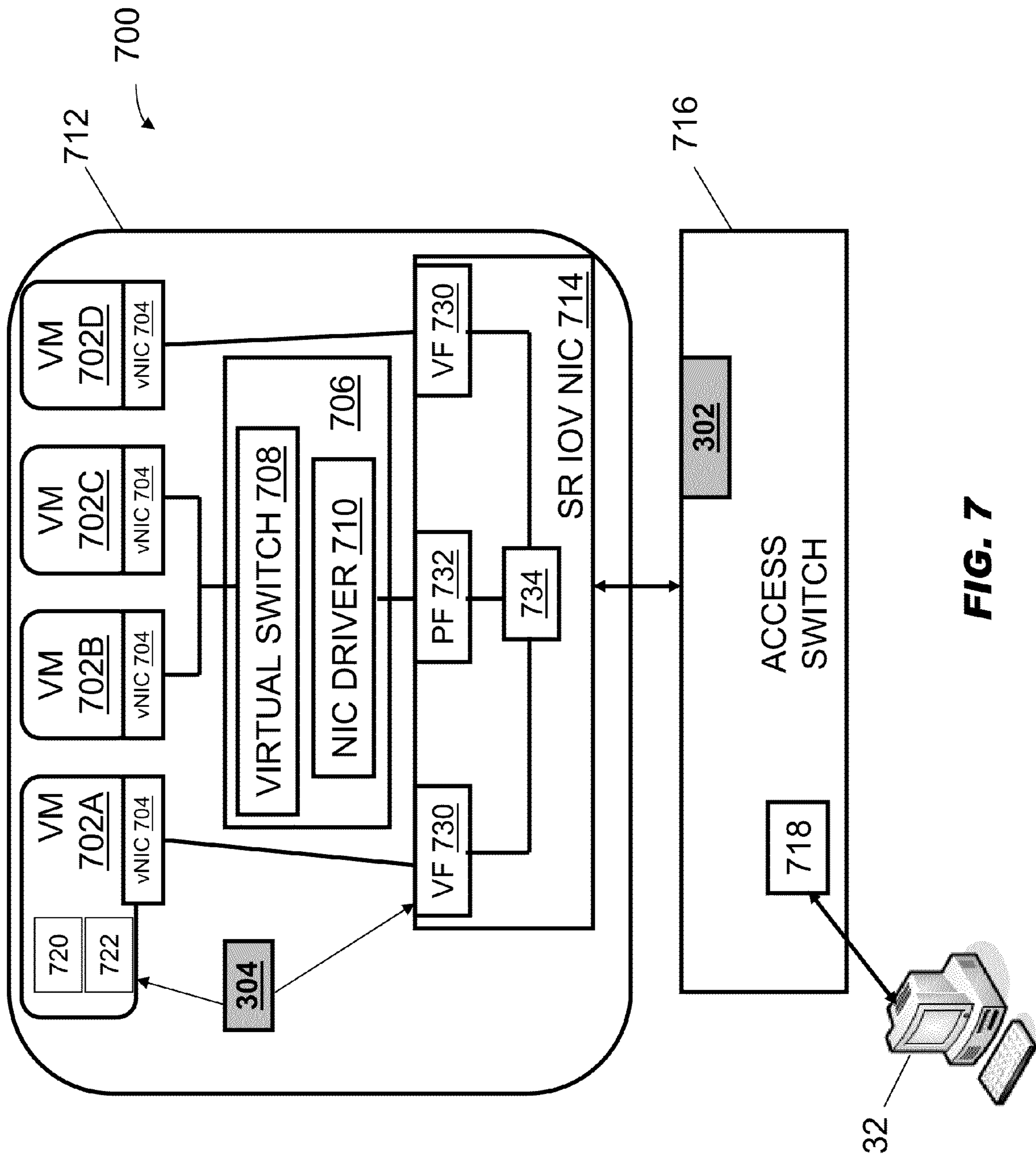

FIG. 7

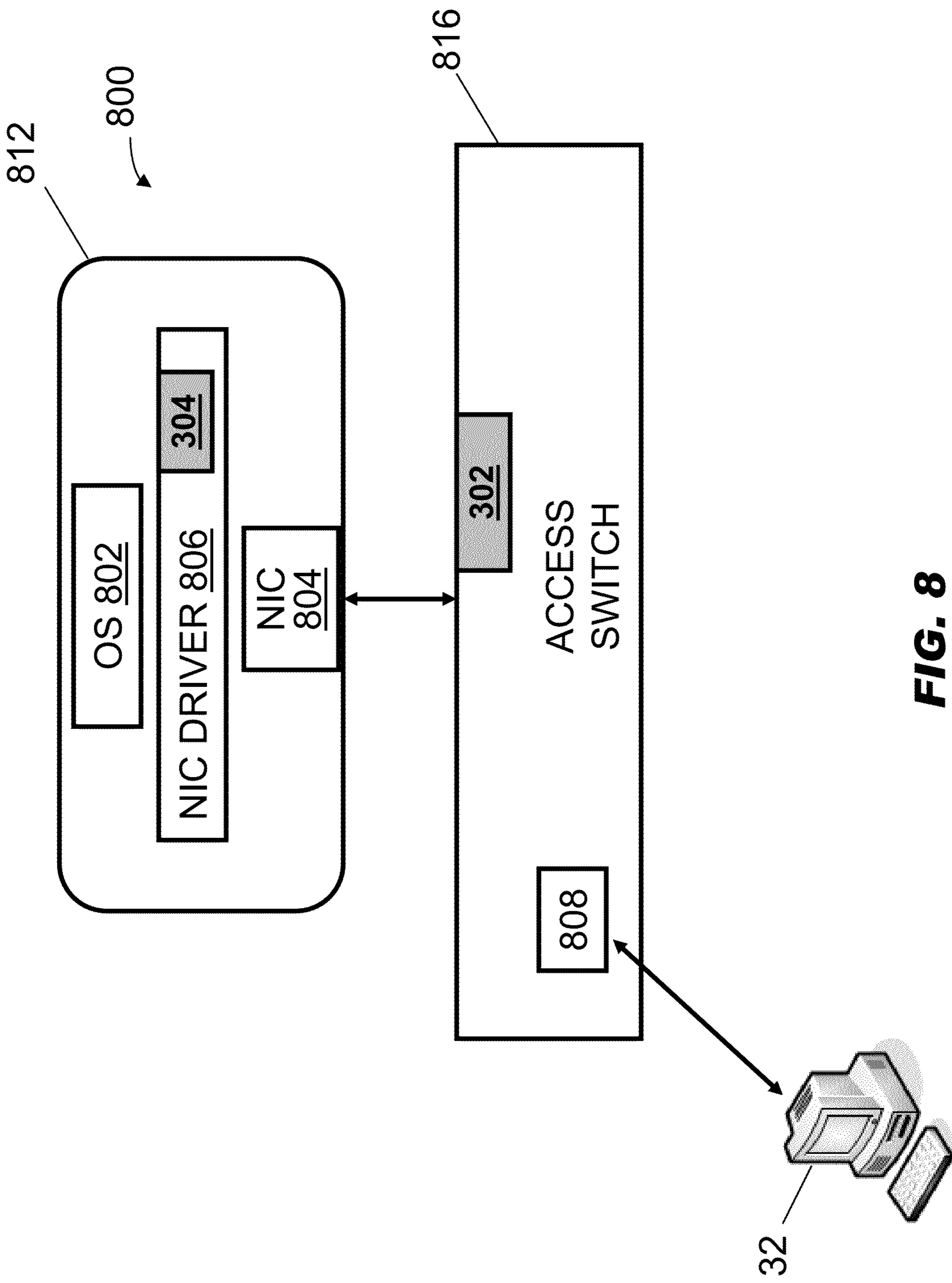
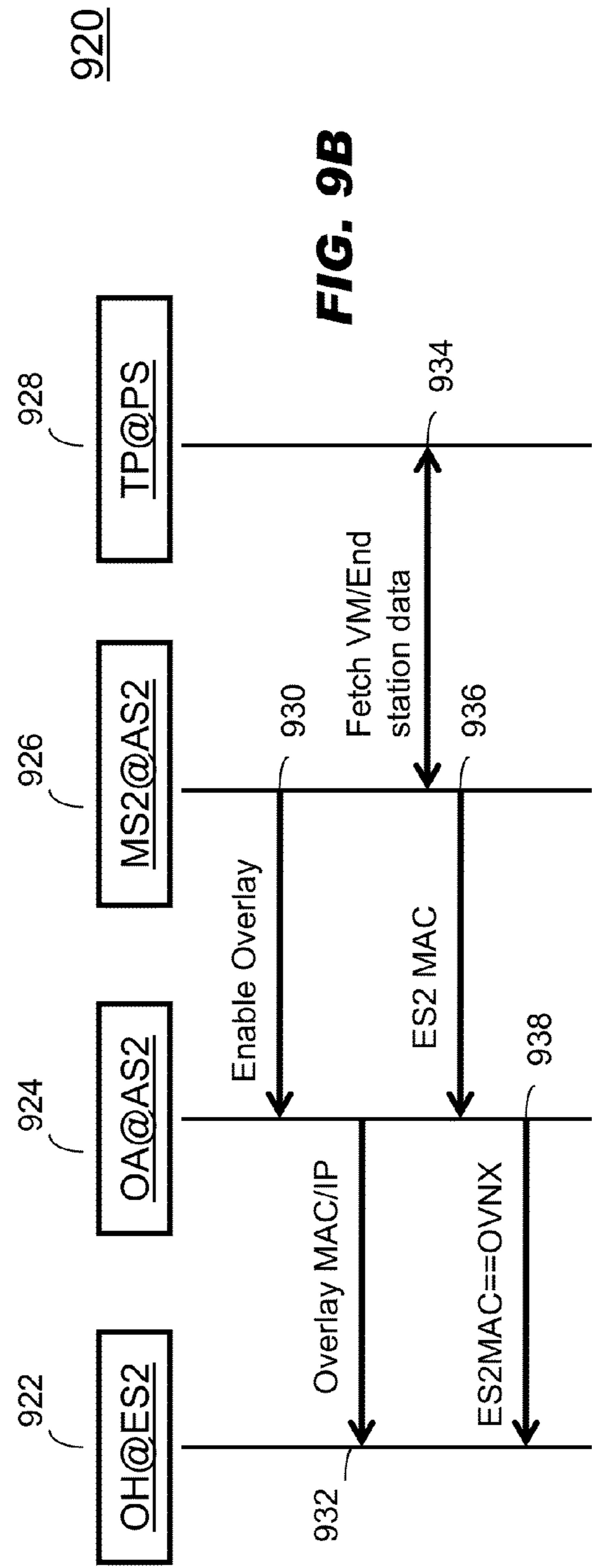
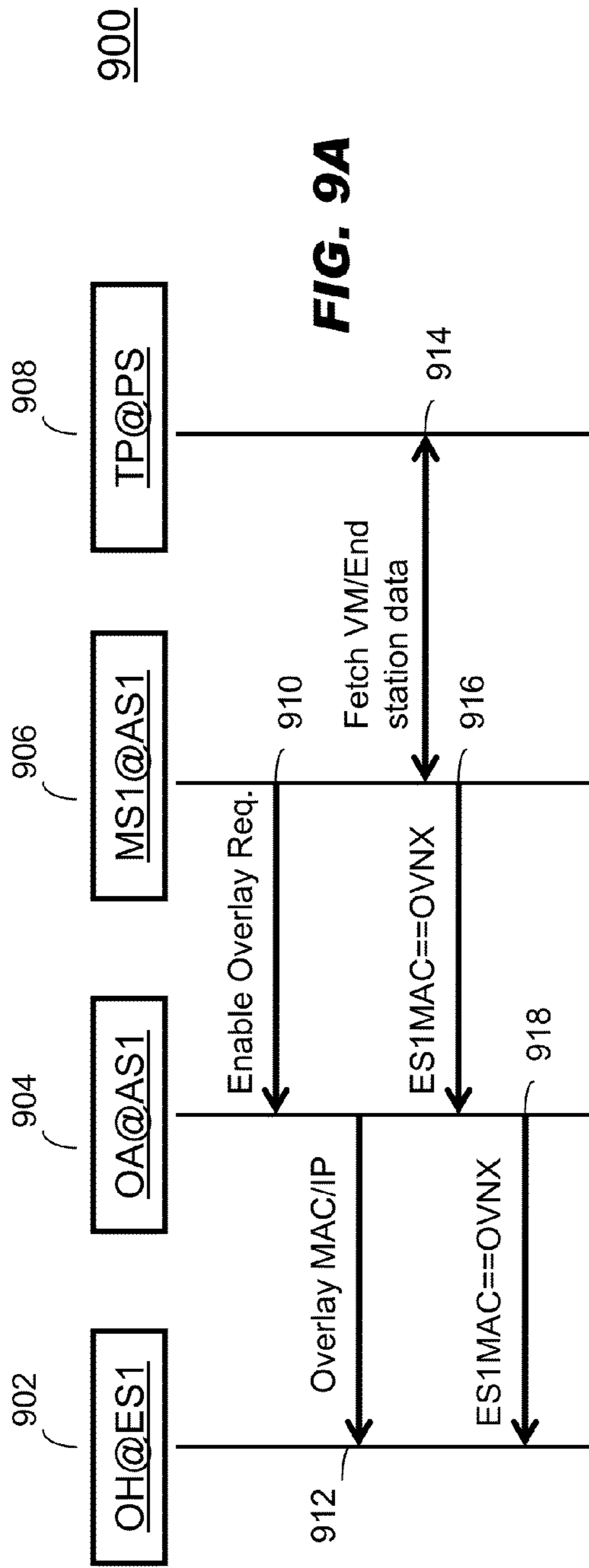

FIG. 8



1000

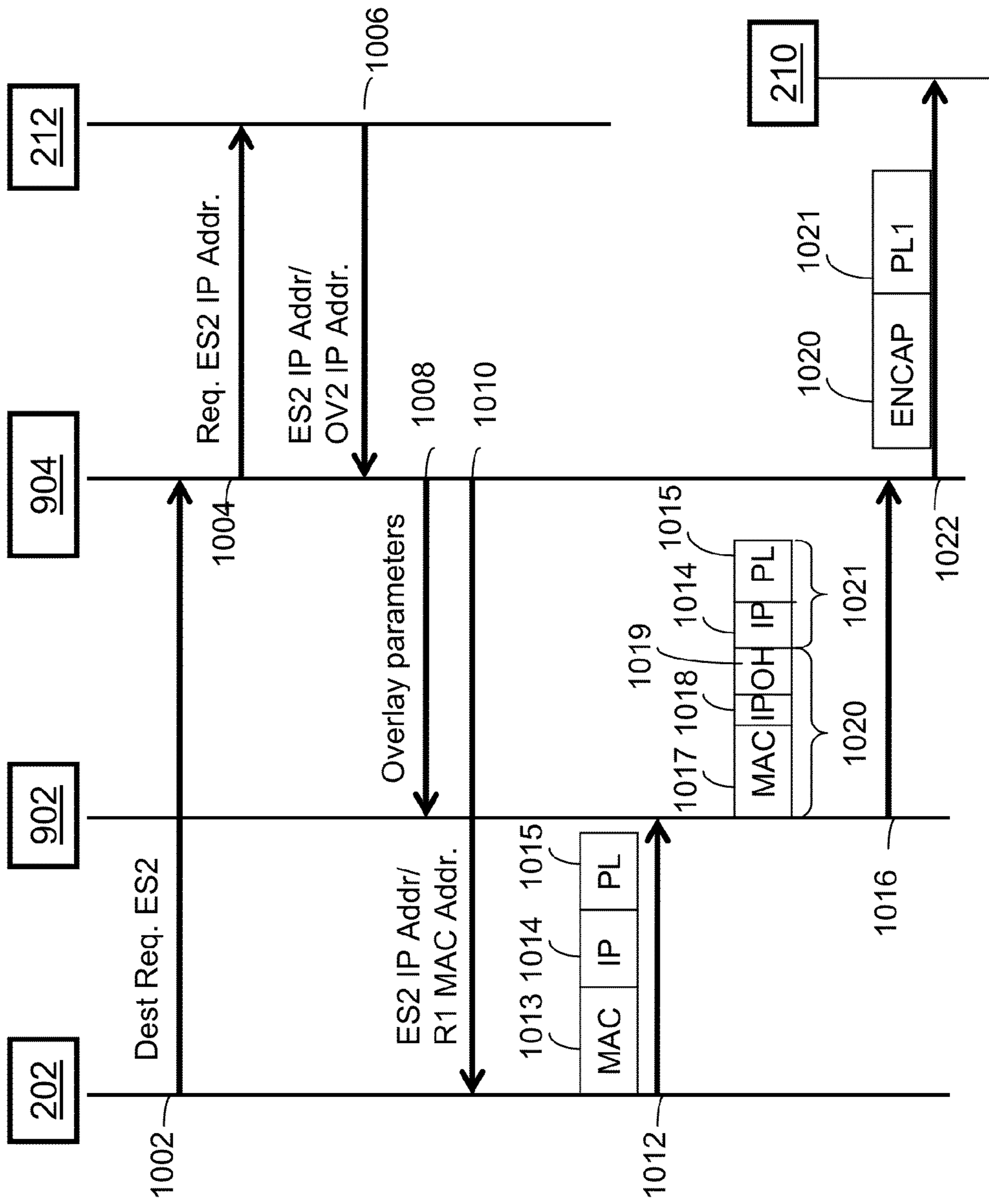

FIG. 10

1100

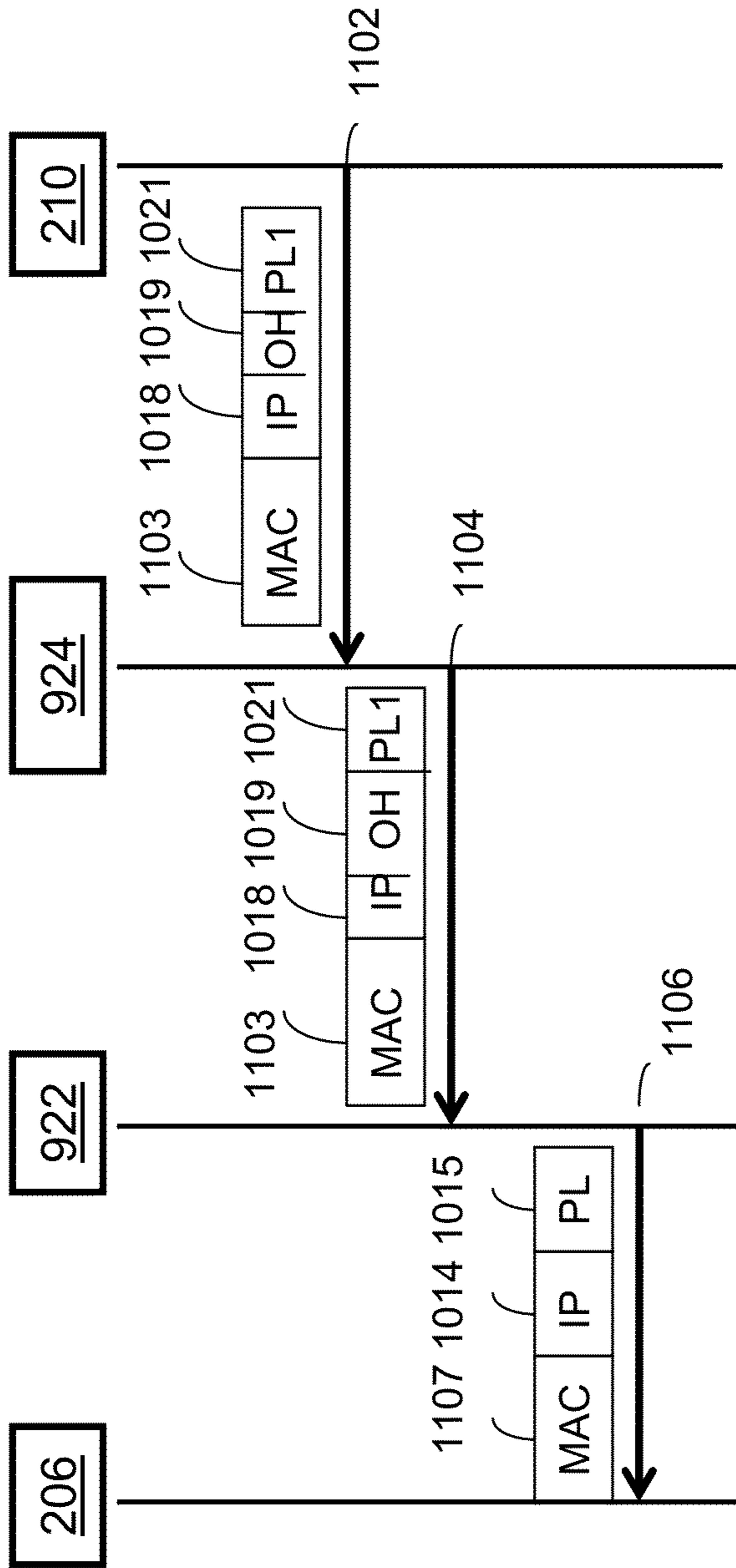

FIG. 11

1**METHODS OF FORMING VIRTUAL NETWORK OVERLAYS**

RELATED APPLICATIONS

This application is a continuation application claiming the benefit of the filing date of U.S. patent application Ser. No. 13/212,790, filed Aug. 18, 2011, entitled "Virtual Network Overlays and Methods of Forming Thereof," contents of which are incorporated by reference herein in their entirety.

FIELD OF THE INVENTION

The present inventive concepts relate generally to network virtualization. More particularly, the present inventive concepts relate to methods for overlaying a virtual network on a physical network.

BACKGROUND

Server virtualization in data centers or related environments is a key enabling technology for cloud computing. In general, server virtualization describes a software abstraction that separates a physical resource and its use from the underlying physical machine. Most physical resources can be abstracted and provisioned as virtualized entities. Accordingly, a single physical machine can host a plurality of virtual machines, each having its own operating system, referred to as a guest operating system (OS), thereby allowing multiple users to share the physical machine.

The desire to overlay virtual networks on physical networks within a data center environment provides several benefits. One well-known benefit is that virtual networks can simplify network provisioning for the data center client in public, private, or multi-tenant cloud environments.

SUMMARY

In one aspect, the present inventive concepts feature a method for overlaying a virtual network on a physical network in a data center environment. The method comprises arranging an overlay system is arranged in an overlay virtual network to include an overlay agent and an overlay helper. The overlay agent is implemented in an access switch. The overlay helper is implemented in an end station that is in communication with the access switch. Overlay parameters are transmitted in compliance with an in-band protocol between the overlay agent and the overlay helper.

In another aspect, the present inventive concepts feature a method for communication in an overlay virtual network. A first overlay system is arranged to include an overlay agent implemented in a first access switch and an overlay helper implemented in a first end station that is in communication with the first access switch. A second overlay system is arranged to include an overlay agent implemented in a second access switch and an overlay helper implemented in a second end station that is in communication with the second access switch. Overlay parameters are transmitted from the overlay agent of the first overlay system to the overlay helper of the first overlay system. The overlay parameters include data for transmitting a data packet from the first end station to the second end station.

BRIEF DESCRIPTION OF THE DRAWINGS

The above and further advantages of this invention may be better understood by referring to the following description in

2

conjunction with the accompanying drawings, in which like numerals indicate like structural elements and features in various figures. The drawings are not necessarily to scale, emphasis instead being placed upon illustrating the principles of the invention.

FIG. 1 is a block diagram of a data center environment in which embodiments of the present inventive concepts can be employed;

FIG. 2 is a block diagram of an environment in which two end stations are in a same overlay virtual network, in accordance with an embodiment;

FIG. 3 is a block diagram illustrating a high-level architecture of an overlay system, in accordance with an embodiment;

FIG. 4 is a schematic block diagram illustrating a process flow for communicating between the end stations and the overlay systems of FIG. 2, in accordance with an embodiment;

FIG. 5 is a flow diagram of a process for performing a virtual network overlay operation, in accordance with an embodiment;

FIG. 6 is a block diagram of an environment including a host computer and an access switch configured with a virtual network overlay, in accordance with an embodiment;

FIG. 7 is a block diagram of an environment including a host computer and an access switch configured with a virtual network overlay, in accordance with another embodiment;

FIG. 8 is a block diagram of an environment including a host computer and an access switch configured with a virtual network overlay, in accordance with another embodiment;

FIG. 9A is a schematic block diagram illustrating a process flow for initializing a source overlay system, in accordance with an embodiment;

FIG. 9B is a schematic block diagram illustrating a process flow for initializing a destination overlay system, in accordance with an embodiment;

FIG. 10 is a schematic block diagram illustrating a process flow for communicating with a source overlay system, in accordance with an embodiment; and

FIG. 11 is a schematic block diagram illustrating a process flow for communicating with a destination overlay system, in accordance with an embodiment.

DETAILED DESCRIPTION

In the following description, specific details are set forth although it should be appreciated by one of ordinary skill that the systems and methods can be practiced without at least some of the details. In some instances, known features or processes are not described in detail so as not to obscure the present invention.

An overlay network typically includes a plurality of overlay agents located at the edge of a physical network. Each overlay agent is configured to classify packets transmitted by a corresponding end station, for example, by mapping packets from a given end station to a virtual network and vice versa. The overlay agents can also add an overlay header to the packets directed to a destination end station, which is populated with virtual network overlay parameters provided by a network management station or a policy server. The parameters can include information for identifying the virtual network of a transmitted packet and for allowing the packet to be transmitted from an overlay agent in communication with the source end station through the physical network to another overlay agent in communication with the destination end station, preferably located in the same virtual network as the source end station. The receiving overlay agent can determine

the correct destination end station from the overlay header, for example, from the virtual network identifier provided in the overlay header.

A limitation associated with conventional overlay configurations is that legacy network devices such as Ethernet switches cannot participate in an overlay operation, since, for example, conventional Ethernet switches cannot recognize the overlay header added to a packet by a source overlay agent, and therefore cannot process the contents of the overlay header such as the virtual network identifier required for determining the correct destination for the packet.

One conventional approach is to provide a server virtualization environment that includes virtual switches, or vswitches, which adds Ethernet or related switching services to virtual machines. Since virtual switches are implemented in the host server software and have access to sufficient amounts of memory and CPU, they can be modified to operate as overlay agents. Examples of virtualization software products that can be used in conjunction with virtualization-aware network switches can include XenSource™ produced by Citrix Systems, Inc., Hyper-V™ produced by Microsoft Corp., VMware®, or open-source software such as Kernel-Based Virtual Machine (KVM).

In a conventional server virtualization environment, non-virtualized end stations cannot be part of an overlay network. Also, virtualization-based solutions rely on vendor-specific virtualization software for implementing the virtual machines on the physical host server, and therefore rely on the availability of proprietary virtual switch extensions and their acceptance on the respective virtual switch platform. Significant development and support resources are required to implement and maintain such an environment.

In brief overview, aspects of the present inventive concepts include an overlay system that is implemented in both a network access switch and a host server, permitting virtualized and non-virtualized network entities alike to be part of the same overlay virtual network. The overlay system includes an overlay agent and a corresponding overlay helper. The overlay agent runs on an access switch or other network edge device to which one or more virtual and/or physical end stations are connected. The overlay helper runs on a host computer, for example, at the Ethernet layer of a network interface controller (NIC) device driver, firmware, or hardware in a conventional non-virtualized server, or in the device driver at a hypervisor of a virtualized server. The overlay agent and the overlay helper communicate with each other by exchanging virtualization parameters and the like via an in-band protocol, for example, a hop-by-hop layer-2 protocol.

In this manner, a highly scalable virtual network environment can be provided by implementing the overlay system in a form of program code, or software, in an access switch and an end station NIC, for example, under the end station's operating system, where overlay network characteristics can be defined in software as an alternative to firmware. Accordingly, an overlay configuration is not required to reside entirely at the edge of a physical network, or to reside entirely in a virtualization server. Thus, so long as an end station is configured with an overlay helper that communicates with the overlay agent in the access switch, both virtualized and non-virtualized end stations can be part of the virtual network domain. Implementing the overlay system in this manner can improve scaling by pooling the resources of the access switch and the network adapter. Otherwise, if the access switch alone included an overlay configuration, the access switch would be required to process overlay-related communications for multiple ports, resulting in an increase in hardware complexity and resources. Since a server-resident network adapter pro-

cesses a subset of the end stations that are local to it, the requirements on the adapter are less intensive; thus, an access switch can offload the handling of certain data plane overlay functions to a server-resident adapter.

FIG. 1 is a block diagram of a data center environment 100 in which embodiments of the present inventive concepts can be employed. In general, the data center environment 100 can include one or more locations that serve as a computational, storage, and networking center for an organization. The equipment of the data center environment 100 can reside together locally at a single site or can be distributed over two or more separate sites.

The data center environment 100 can include one or more host computers 12 in communication with a network 14 through an access switch 16. Although not shown, the data center environment 100 can include one or more aggregator and gateway switches interposed between the access switch 16 and the network 14, and/or other well-known data center equipment. The access switch 16 and/or related data center equipment can be considered part of the network 14. The network 14 can be, for example, an intranet, an extranet, the Internet, a local area network (LAN), wide area network (WAN), or a metropolitan area network (MAN), or any combination thereof. The host computer 12 can communicate with the access switch 16 via another network 30, for example, an Ethernet LAN, or via a direct connection. Alternatively, network 30 can be part of the network 14 such that the host computer 12 communicates directly with the network 14.

The host computer 12 can be an embodiment of a physical computing device, such as a server or a blade. The host computer 12 can reside alone or be installed in a chassis with other host computers, for example, as in a rack server or in a blade server. The access switch 16 can reside alone or be installed within the same equipment chassis as the host computer 12.

The host computer 12 can include one or more processing devices 20 such as a CPU, and can further include a memory device 22 and a physical network input/output (I/O) adapter 24 having at least one physical network interface (NIC). The physical components of the host computer 12, e.g., the CPU 20, the memory device 22, and the I/O adaptor 24, can communicate with each via one or more busses, connectors, adapters, and the like known to those of ordinary skill in the art. The host computer 12 can run a virtualization system 18, which can optionally include a hypervisor or a virtual machine manager (VMM). In other embodiments, the host computer 12 can be a non-virtualized server or a server blade.

The memory 22 can include volatile memory, for example, RAM and the like, and/or non-volatile memory, for example, ROM, flash memory, and the like. The memory can include removable and/or non-removable storage media implemented in accordance with methods and technologies known to those of ordinary skill in the art for storing data. Stored in the memory can include program code, such as program code of an operating system 34 executed by the processor 20, and/or program code corresponding to a virtualization system 18.

The NIC 24 provides support in hardware, software, or a combination thereof for any form of I/O virtualization. Examples include, but are not limited to, SR-IOV NICs and non-SR-IOV NICs, multi-queue NICs, network interface controllers, I/O adapters, and converged network adapters. The NIC 24 can be managed by the server operating system 34, a NIC driver, and the like so that the NIC 24 can receive and transmit data to and from the network 30, described in detail below. In addition to handling the network I/O to and

from the access switch **16**, the NIC **24** provides for a communication path between virtual machines (not shown), for example, exchanging packets with a virtual NIC (vNIC) of a virtual machine.

The access switch **16** includes a plurality of physical uplink and downlink ports **26** that communicate with the NIC **24**, more specifically, with a physical port (not shown) of the NIC **24**. In general, the access switch **16** is a network element, for example, implemented as an Ethernet switch, for switching computers between uplink and downlink ports **26**, and between virtual machines executing on the same host computer **12**. An example implementation of the physical link between the host computer **12** and the access switch **16** is a 10 Gb Ethernet link. An example implementation of the access switch **16** is an Ethernet switch, e.g., a 24-port 10 Gb Ethernet switch module manufactured by Blade Network Technologies, Inc. of Santa Clara, Calif. In other embodiments, switching can occur at a network adapter configured with elements of an overlay system. Here, switching can occur between virtual machines in communication with the network adapter, and/or with an access switch.

The access switch **16** can be configured with a management module **28** for performing intra-hypervisor VM-to-VM switching and the like. A remote management station **32** can control and manage the access switch **16** and/or the host computer **12** via the management module **28**. The access switch **16** can include an overlay agent **36** in communication with an external policy server and/or the management station **32** via a management module **28** for providing network topology information, classifying packets, etc. The overlay agent **36** is configured to perform a virtual network overlay operation, for example, enabling two or more end stations to communicate in the overlay virtual network.

FIG. **2** is a block diagram of an environment **200** in which two end stations **202**, **206** are in a same overlay virtual network, in accordance with an embodiment. End stations **202**, **206** can exchange data packets with each other via a router **212**. One or more access switches (not shown) can be positioned between end stations **202**, **206** and a router **210**. In an embodiment, end stations **202**, **206** are configured for different physical subnets, and can be members of a common virtual network. Accordingly, the router **212** includes a first subnet interface R1 for servicing a first subnet of which end station **202** is a member, and a second subnet interface R2 for servicing a second subnet of which end station **206** is a member. In other embodiments, end stations **202**, **206** are configured as part of a same physical network, for example, a physical layer-2 network, or on a same subnet, for example, a same layer-3, e.g., IP, subnet. For purposes of describing operations performed in the environment **200**, overlay system **204** of FIG. **2** can be referred to as a source overlay system, and overlay system **208** of FIG. **2** can be referred to as a destination overlay system. In an embodiment as shown in FIG. **2**, the environment **200** includes an IP network. In other embodiments, the environment **200** includes a layer-2 network.

End station **202** is in communication with overlay system A **204** and end station **206** is in communication with overlay system B **208**. Overlay system A **204** and/or overlay system B **206** can service multiple end stations. Overlay systems **204**, **206** can communicate with each other when performing an overlay operation, for example, described below. End station **202** and/or end station **206** can be virtualized end stations. Alternatively, end station **202** and/or end station **206** can be non-virtualized end stations. The environment **200** can therefore include a combination of virtualized and non-virtualized end stations.

FIG. **3** is a block diagram illustrating a high-level architecture of an overlay system **300**, in accordance with an embodiment. The overlay system architecture described with respect to FIG. **3** can apply to overlay system A **204** and/or overlay system B **208** described with reference to FIG. **2**. Thus, overlay system A **204** and overlay system B **208** each include some or all of elements of the overlay system **300**. In describing FIG. **3**, reference can be made to other elements of FIG. **1** and/or FIG. **2**. The overlay system **300** can be configured for an IP network, a layer-2 network, or other network known to those of ordinary skill in the art.

Overlay system **300** includes an overlay agent **302** and an overlay helper **304**. The overlay agent **302** can be located at the access switch **16** of FIG. **1** or the router **210** or edge switch (not shown) of FIG. **2**. The overlay helper **304** can be located at the host computer **12** of FIG. **1** or end station **202** and/or end station **206** of FIG. **2**, for example, in an Ethernet device driver.

The overlay agent **302** includes a management interface **306**, a policy agent **308**, an address handler **310**, and a classifier **312A**. The management interface **306** provides an interface to the management station **32** for configuring overlay parameters and providing various control and management functions to the overlay virtual network in which the overlay system **300** is implemented. For example, the management station **32** via the management interface **306** can define virtual networks and their members. The management station **32** can also interact with devices and other specialized management stations in a data center, such as network switches, virtualization managers, server managers, and the like, for performing tasks related to the management of an overlay virtual network such as constructing topology maps, determining placement criteria, and the like. In an embodiment, the management interface **306** is configured for providing a global view of the physical network and/or the virtual network to the management station **32**. The management interface **306** can convey local parameters, for example, packet classification criteria, to other components of the overlay system **300**. For example, the management station **32** can configure an identifier associated with a virtual network. The overlay agent **302** can then configure the classifier **312A** for a pre-determined traffic classification based on a physical or virtual port number, a MAC address, and the like.

The policy agent **308** can communicate with the policy server **212**, also referred to as a policy engine, to construct a policy cache containing the IP address or related data of a destination overlay agent corresponding to a destination end station in a given virtual network. The policy cache includes mappings for destination end stations that local end stations wish to communicate with. The policy server **212** can determine the location of, and obtain IP addresses for, one or more end stations in the overlay network by interacting with various components of a data center environment such as end stations **202**, **206**, overlay systems **204**, **208**, and/or edge switches (not shown) in FIG. **2**. In another embodiment, the management station **32** communicates with the policy server **212** via the management interface **306** to providing mapping-related information for establishing communication paths for end stations **202**, **206**.

The address handler **310** receives and processes address resolution protocol (ARP) requests or layer-2-related communications from end stations **202**, **206**. Details of the ARP protocol are not disclosed herein for brevity since ARP is a well-known protocol used to associate IP addresses with MAC addresses or other layer 2 addresses. The address handler **310** can query the policy agent **308** for an IP address of the destination overlay agent for communicating with a target

end station that is in the source end station's virtual network, and determine a next hop MAC address, for example, according to the ARP protocol, for the destination overlay agent's IP address. The next hop determination can occur via normal ARP mechanisms, for example, in the physical network. In embodiments where a layer-2 network and a corresponding layer-2 virtual network service are provided, the address handler 310 is not part of the overlay system 300. Here, packets can be classified based on a destination MAC address instead of a destination IP address. A virtual network identifier can therefore alternatively qualify a MAC address instead of an IP address.

The overlay helper 304 of the overlay system 300 includes an IP handler 314 and a classifier 312B, which is part of the classifier 312A of the overlay agent 302. The classifier 312A in the overlay agent 302 processes received data traffic, in particular, traffic destined to one of the local end stations serviced by the overlay system. The classifier 312B in the overlay helper 304 on the other hand processes packets for transmission. For example, the classifier 312B receives IP packets or layer 2 data and the like from the end station, for example, end station 202, and map the packets to a virtual network. This mapping can be configured via the management interface 306. As used herein, the classifier 312A of the overlay agent 302 and the classifier 312B of the overlay helper 304 can be referred to generally as a classifier 312. In sum, the classifier 312 maps all packets coming from a local end station to a virtual network based on a previously configured virtual port or MAC-based classification, for example, configured by the management station 32. Thus, all packets transmitted by the end station are transmitted through the classifier 312, where the classifier 312 maps the received packets to a virtual network.

The IP handler 314 receives IP packets from the end station via the classifier 312, and adds an overlay encapsulation to each received IP packet. The overlay encapsulation can include an outer overlay MAC header, an outer overlay IP header, and an overlay-specific header. The outer overlay MAC header can include a source MAC address corresponding to overlay system A 204 and a destination MAC address corresponding to the next hop IP address of the target overlay IP address. The outer overlay IP header can include the IP address of the source overlay system 204 and the IP address of overlay system B 208. The overlay-specific header can include a unique identifier that identifies the virtual network.

The IP handler 314 of the destination overlay system 208 can receive encapsulated IP packets sent from the source overlay system 204 and can locate the destination end station 206 that the packet is intended for, based on the inner IP destination, i.e., the IP address of the destination end station 206, and the virtual network identifier. The IP handler 314 of the destination overlay system 208 can communicate with the policy agent 308 to retrieve mapping information for the destination end station 206. The local destination can be derived from the packet contents and the target port can be identified from its settings. Here, a lookup may not be required. On the other hand, a lookup may be nevertheless necessary if the target has changed locations. The IP handler 314 can query the local policy agent 308, which in turn queries the global policy server 212 if the mapping is not found in the local cache. Once the end station is identified, the IP Handler 314 strips off the overlay header before forwarding the packet frame to the destination end station 206.

FIG. 4 is a schematic block diagram illustrating a process flow 400 for communicating between the end stations 202, 206 and overlay systems 204, 208 of FIG. 2, in accordance with an embodiment. In describing the process flow 400,

reference is also made to FIGS. 1-3. The process flow 400 can be governed by instructions that are stored in a memory device and executed by a processor of at least one of end station 202, end station 206, router 210, policy server 212, and/or one or more intervening switches (not shown) between end stations 202, 206 and the router 210. In FIG. 4, end station 202 can be referred to as a source end station and end station 206 can be referred to as a destination end station. Also in FIG. 4, overlay system A 204 can be referred to as a source overlay system, and overlay system B 208 can be referred to as a destination overlay system. Although overlay systems 204, 208 are referred to herein, the overlay system 300 described in FIG. 3 equally applies.

A destination request message is output (402) from end station 202 to overlay system A 204, for example, output as a broadcast message. The broadcast message can be output in a well-known manner, for example, issued according to the ARP for address resolution. Alternatively, the destination request message can be output in a layer-2 format. Here, the policy cache can be updated when a unicast message to the destination endpoint is received by the overlay system 300.

The source overlay system 204 can receive the destination request message, whereby the address handler 310 of the overlay agent 302 of the source overlay system 204 can query the policy agent 308 for the IP address of the destination overlay system 208 related to the destination end station 206 in a predefined virtual network. The policy agent 308 of the source overlay system 204 can first access its policy cache (not shown), which can store mapping information related to the destination overlay system 208 of the destination end station 206 to which the source end station 202 wishes to communicate. If such mapping information is not found in the policy cache, then the address handler 310 can output (404) a message, for example, a unicast message, to the policy server 212 to obtain the mapping information. In particular, the overlay system 300 requests the policy server 212 for the location of the target overlay system to which the destination endpoint 206 is attached in the same virtual network as the source endpoint 202. The policy server 212 can determine the physical location of the destination end station 206 by interacting with elements of the data center and with the source overlay system 204.

Assuming that the policy server 212 determines the location of the destination end station 206 and can provide the requested mapping information, the policy server 212 can output (406) the requested mapping information, specifically, a mapping of the IP address of the destination end station 206 to the destination overlay system 208. For example, the address handler 310 can query the policy cache, and if not found there, the policy agent 308 contacts the policy server 212 to retrieve the mapping information and return it to the address handler 310. The address handler 310 can then fulfill the ARP request originating from the local end station, i.e., the source endpoint 202. In addition, the policy agent 308 can communicate with the policy server 212 to determine the location of the destination end station 206, and to update the policy cache with the mapping information.

The address handler 310 of the source overlay system 204 can output (408) the IP address of the destination end station 206 and a corresponding next hop MAC address generated in response to the original ARP request to the end station 202. After address resolution, the source end station 202 can output (410) a packet that includes a layer-2, e.g., Ethernet, header 411, an IP header 412, and a payload (PL) 413. The layer-2 header 411 can include the next hop MAC address (R1

MAC Addr.) and the destination IP address (ES2 IP Addr.) received from the policy server **212** and/or the policy agent **308**

The overlay system A **204**, in particular, the IP handler **314**, receives the packet from the end station **202**. The IP handler **314** adds an overlay encapsulation **418** to the packet and outputs (**414**) the encapsulated packet. The overlay encapsulation **418** includes an outer overlay MAC header **415**, an outer overlay IP header **416**, and an overlay header **417**. An optional layer-4 header (not shown), for example, a UDP header, can be positioned between the IP header **416** and the overlay header **417**. The outer overlay MAC header **413** includes a source MAC address (omac1) corresponding to the source overlay system **204** and a destination MAC address, e.g., the next hop MAC address (rmac1). In an embodiment, if the target is in the same subnet as the source, then the destination MAC address is that of the destination overlay system **208**. In another embodiment, as shown in FIG. 2, the destination MAC address is that of a gateway interface (R1) that routes packets between the subnets of the end stations **202**, **206**, respectively.

The outer overlay IP header **416** can include the IP address of the source overlay system **204** and the IP address of the destination overlay system **208**. The overlay header **417** can include a unique identifier that identifies the virtual network. When the overlay encapsulation **418** is added to the packet received from the source end station **202**, the contents of the original packet **411**, **412**, **413** are combined to form a new payload PL1 **419**, which is output (**414**) with the overlay encapsulation **418** to the router **210**, or alternatively to an edge switch or related network switch.

The router **210**, specifically, a first subnet interface R1 of the router **210** identified from the next hop MAC address, receives the packet with the payload PL1 **419**, and outputs (**420**) the payload PL1 **419** as well as contents the overlay header **417** and the outer overlay IP header **416** from a second interface R2 that services a second subnet of which destination end station **206** and/or destination overlay system **208** is a member. A MAC address header **421** is added which includes the source MAC address, i.e., the MAC address of the second router interface R2, and the MAC address of the destination overlay agent **208** corresponding to the IP address of the destination overlay system **208** in the outer overlay IP header **416**.

Overlay system B **208** can remove the overlay header **417** from the packet received from the router **210**, and output the original payload **413** to the destination end station **206**. The IP handler **314** of the destination overlay system **208** can determine the intended destination end station for receiving the packet based on the inner IP destination (esip2) provided in the destination IP address field **412** and virtual network information, for example, a unique virtual network identifier, in the overlay header **417**. Overlay system B **208** can use this information to determine the destination end station **206**, and to output (**422**) a data packet including the original payload **413** to the destination end station **206**.

FIG. 5 is a flow diagram of a method **500** for performing an overlay operation, in accordance with an embodiment. In describing the method **500**, reference is also made to elements of FIGS. 1-4.

At block **502**, the overlay agent **302** of the overlay system **300** can be implemented in the access switch **16** or related network edge device. As described above, the overlay agent **302** can include a management interface **306**, a policy agent **308**, an address handler **310**, and a classifier **312A**.

At block **504**, the overlay helper **304** is implemented in the host computer **12**. As described above, the overlay helper **304**

can include an IP handler **314** and a classifier **312**. In one embodiment, the overlay helper **304** is implemented in a hypervisor NIC driver. In another environment, the overlay helper **304** is implemented in an SR IOV NIC. In another environment, the overlay helper **304** is implemented in a legacy NIC, an OS NIC driver, and/or NIC firmware or hardware.

At block **506**, overlay parameters can be transmitted from the overlay agent **302** to the overlay helper **304** via an in-band protocol. Classification criteria based on physical or virtual port numbers, MAC addresses, and the like can be exchanged prior to the start of a traffic flow between the two end stations. Policy cache entries and the like can be exchanged at the start of the traffic flow. Encapsulation can occur by adding an overlay header to a received packet, which includes IP and/or MAC address information, virtual network information, and/or related information for determining the destination end station of the packet in the overlay virtual network. Accordingly, by implementing an overlay system **300** in both an access switch and an end station, a virtual network can be scaled to include legacy devices in addition to virtualized devices, thereby reducing any dependency on hypervisor platforms and the like. In doing so, the overlay virtual network functionality can be separated from the operating system or hypervisor. Further, overlay header additions, deletions, or modifications performed by the overlay helper can occur in a hardware, firmware, or software layer below the host computer operating system. Thus, overlay functions can occur without the need to modify the operating system.

FIG. 6 is a block diagram of an environment **600** including a host computer **612** and an access switch **616** configured with the virtual network overlay system **300**, in accordance with an embodiment.

The host computer **612** includes a hypervisor **606** for abstracting the hardware of the host computer **12** into virtual machines **602-1** through **602-N** (generally, **602**). The virtual machines **602** share a physical network interface controller (NIC) **614** for performing external network I/O operations. The hypervisor **606** can include a software-based virtual switch **608**, or vswitch, that provides interconnectivity among the virtual machines **602**. The virtual switch **608** interfaces between the physical NIC **614** and a plurality of virtual NICs **604**, or vNICs, of the virtual machines **602** for forwarding packets between the virtual machines **602** and the physical NIC **614**. Each virtual machine **602** can have one or more associated vNICs **604**. Each virtual machine **602** can also include a VM network stack **620** and a VM vNIC driver **622** that drives a corresponding vNIC **604**. In general, each vNIC **604** operates like a physical network interface. For example, each vNIC **604** can be assigned a unique MAC (Media Access Control) address.

The vNICs **604** are logically connected to the physical NIC **614** through the hypervisor NIC driver **610** and the virtual switch **608**. In an embodiment, the overlay helper **304** of the overlay system **300** is implemented in the hypervisor NIC driver **610**, or alternatively in the NIC firmware or hardware. The overlay agent **302** of the overlay system **300** can be implemented in the access switch **616**. In another embodiment, the overlay helper **304** is implemented in the VM network stack **620**. In another embodiment, the overlay helper **304** is implemented at the VM vNIC driver **622**. In another embodiment, the overlay helper **304** is implemented in a combination of the VM network stack **620**, the vNIC driver **622**, and hypervisor NIC driver **610**. The overlay agent **302** and the overlay helper **304** communicate with each other via an in-band protocol for transmitting overlay parameters, for example, classification criteria and policy cache data such as

11

virtual network mapping information, between the overlay agent 302 and the overlay helper 304.

FIG. 7 is a block diagram of an environment 700 including a host computer 712 and an access switch 716 configured with the virtual network overlay system 300, in accordance with another embodiment. The environment 700 is similar to the environment 600 described in FIG. 6, except that the environment 700 includes an SR-IOV NIC 714. Here, a vNIC 704 can be logically connected to the physical NIC 714 through a virtual function (VF) engine 730, which can include a virtualized instance of the NIC 714. A hypervisor NIC driver 710 can drive a physical function (PF) engine, similar to the configuration of FIG. 6 so that the hypervisor 706 can access the PF 732, which is the interface to the physical card. The VF engines 730 permit switching traffic performance to be improved by switching traffic between virtual machines 702 by bypassing the vswitch 708. Thus, VMs 702A, 702D can directly access the physical NIC 714 through the virtual functions without having to rely on the hypervisor 706 for control or data operations

In an embodiment, the overlay helper 304 of the overlay system 300 is implemented in the NIC driver 710 which drives the PF 732, or in the NIC firmware or hardware. The overlay agent 302 of the overlay system 300 can be implemented in the access switch 616. In another embodiment, the overlay helper 304 is implemented in a VM network stack 720. In another embodiment, the overlay helper 304 is implemented at the VM vNIC driver 722. In another embodiment, the overlay helper 304 is implemented in a combination of the VM network stack 720, the vNIC driver 722, and the NIC driver 710.

FIG. 8 is a block diagram of an environment 800 including a host computer 812 and an access switch 816 configured with the virtual network overlay system 300, in accordance with another embodiment. The host computer 812 can include a conventional operating system, and does not require a hypervisor or VMM.

The host computer 812 can include a NIC 804 configured for network virtualization, for example, including queues each dedicated to a virtualized or non-virtualized entity on the physical host computer 12. Here, a unique MAC address can be assigned to each queue to distinguish the entities from each other. The overlay helper 304 of the overlay system 300 can be implemented in an OS NIC driver 806 that drives the NIC 804, or in the firmware or hardware of the NIC 804. The overlay agent 302 of the overlay system 300 can be implemented in the access switch 816. The overlay agent 302 and the overlay helper 304 communicate with each other via an in-band protocol, which can be configured to exchange overlay parameters and the like. Thus, both virtualized end stations and/or non-virtualized end stations can be part of a scalable overlay virtual network.

FIG. 9A is a schematic block diagram illustrating a process flow 900 for initializing a source overlay system, in accordance with an embodiment. FIG. 9B is a schematic block diagram illustrating a process flow 920 for initializing a destination overlay system, in accordance with an embodiment. In describing the process flows 900 and 920, reference is also made to FIGS. 1-8. In FIGS. 9A and 9B, two overlay systems corresponding to a source end station (ES1) and a destination end station, respectively, are initialized for permitting communication to occur between the two end stations in the same overlay virtual network. Each of the two overlay systems can refer to the overlay system 300 of FIG. 3, and/or the overlay systems 204, 208, respectively, of FIG. 2.

In FIG. 9A, the process flow 900 occurs between the source overlay helper 304 implemented in the source end station 202

12

(generally, 902), the source overlay agent 302 implemented in a source access switch (generally, 904), a management station in communication with the source access switch (generally, 906), and a topology mapper configured for the policy server 212 (generally, 908).

The management station 906 can output (910) an enable overlay request to the source access switch 904. The management station 906 can communicate with the management interface 306 of the source overlay agent 904 to enable the source overlay system 300 to classify packets, add an overlay header to a received packet, to communicate with the source overlay helper 902 via an in-band protocol, and/or to perform other functions of the overlay system 300 such as those described herein. The management station 906 can configure the request to enable a predetermined port of the source access switch for processing packets related to the overlay virtual network to which the source end station 202 belongs. The port can be designated to be in the user defined virtual network. Thus, packets output from that port are automatically classified to belong to the designated virtual network. The source overlay system 300 can perform the required encapsulation as described herein to transmit the packet through the physical network to the destination overlay system.

In response to being activated for a virtual overlay operation, the overlay agent 904 can output (912) address information, for example, the MAC address and/or the IP address of the source overlay agent 904, to the source overlay helper 902.

The management station 906 can send (914) a request to the topology mapper 908 via the management interface 306 for physical locations of the end stations to construct a topology map or determine placement criteria related to the overlay virtual network (OVNX) of which the source end station 202 is associated, i.e., source end station 902 can be a member of OVNX.

The management station 906 can output (916) topology mapping information received from the topology mapper 908 to the source overlay agent 904, specifically, to the policy agent 308. This information can be used by other overlay agents in a virtual network operation whereby communications occur, for example, when the end station 902 receives a packet from another end station, i.e., end station 902 is a destination end station. The topology mapping information can include a source end station MAC address, access switch port information, virtual network identifier, and the like.

Some or all elements of the topology mapping data, for example, source end station MAC address and virtual network identifier, can be output (918) to the overlay helper 902 for establishing a location of the source end station 202.

In FIG. 9B, a process flow 920 occurs between the overlay helper 304 implemented in the destination end station 206 (generally, 922), the overlay agent 302 implemented in a destination access switch (generally, 924), a management station in communication with the destination access switch (generally, 926), and the topology mapper configured for the policy server 212 (generally, 928). The destination access switch 924 can be the same switch or a similar switch as the source access switch 904 of FIG. 9A. The management station 926 can be the same or similar to the management station 906 of FIG. 9A. The topology mapper 928 can be the same as the topology mapper 908 of FIG. 9A.

The management station 926 can output (930) an enable overlay request to the destination access switch 924. The management station 926 can communicate with the management interface 306 of the destination overlay agent 924 to enable the overlay system 300 to classify packets, add an

overlay header to a received packet, to communicate with the destination overlay helper **922** via an in-band protocol, and/or to perform other functions of the overlay system **300** such as those described herein. The management station **926** can configure the request to enable a predetermined port Q of the destination access switch for processing packets related to the overlay virtual network to which the destination end station **222** belongs.

In response to being activated for a virtual overlay operation, the overlay agent **924** can output (**932**) address information, for example, the MAC address and/or the IP address of the destination overlay agent **924**, to the destination overlay helper **922**.

The management station **926** can send (**934**) a request to the topology mapper **928** via the management interface **306** for end station location information to construct a topology map, determine placement criteria, etc., related to the overlay virtual network (OVNX) of which the destination end station **206** is associated, i.e., destination end station **922** can be a member of OVNX. The management station **926** can output (**936**) topology mapping information to the policy server **928** that is queried by the overlay agent **924** to establish a transmission path. This information can be used by other overlay agents in a virtual network operation, for example, when the end station is a destination end station. The topology mapping information can include a destination end station MAC address, access switch port information, virtual network identifier, and the like.

Some or all elements of the topology mapping data, for example, destination end station MAC address and virtual network identifier, can be output (**938**) to the overlay helper **922** for establishing a location of the destination end station **206**.

FIG. **10** is a schematic block diagram illustrating a process flow **1000** for communicating with a source overlay system, in accordance with an embodiment. In describing the process flow **1000**, reference is also made to elements of FIGS. **1-9**. In particular, the process flow **1000** is described as occurring between the first end station **202**, the router **210**, and the policy server **212** of FIG. **2** and the source overlay helper **304** implemented in the source end station **202** (generally, **902**) and the source overlay agent **302** implemented in the source access switch (generally, **904**) of FIG. **9**. However, the process flow **1000** can equally apply between end stations and the access switches referred to in FIGS. **6-8** or in other figures described herein.

A destination request message is output (**1002**) from the end station **202** to the source overlay agent **904**, for example, output as a broadcast message. The broadcast message can be output in a well-known manner, for example, issued according to the ARP for address resolution.

The address handler **310** of the source overlay agent **904** can receive the request via the classifier **312**, and query the policy agent **308** for the IP address of the destination end station **206**, for example, the virtual network (OVNX) of the source end station **202**. The policy agent **308** of the source overlay agent **904** can first access its policy cache (not shown), which can store mapping information related to the destination end station **206** to which the source end station **202** wishes to communicate. The address handler **310** can communicate with the policy agent **308**, which can check a local cache. If the mapping information is not found, the policy server **212** can provide the mapping information. A unicast message can be output (**1004**) to the policy server **212** to obtain the mapping information.

The policy server **212** can determine the physical location of the destination end station **206** according to approaches

similar to those described above with regard to FIG. **4**. Such approaches will not be repeated for reasons related to brevity. The policy server **212** can output (**1006**) the requested mapping information, specifically, a mapping of the IP address of the destination end station **206** to the destination overlay system. In addition, the policy agent **308** can communicate with the policy server **212** to determine the location of the destination end station **206**, and to update the policy cache with the mapping information. The source overlay agent **904** can send (**1008**) overlay parameters such as classification criteria and policy cache data to the source overlay helper **902**. For example, the source overlay agent **904** can send next-hop MAC and IP address data as well as related overlay encapsulation information, for example, described herein. The source overlay agent **904** can communicate with the source overlay helper **902** via an in-band protocol. The source overlay agent **904** can output (**1010**) the IP address of the destination end station **206** and a corresponding next hop MAC address to the end station **202**.

End station **202** can output (**1012**) a packet. The packet can include a network packet, for example, a frame or an IP packet. The packet can include a destination MAC address **1013** and a destination IP address **1014** received from the source overlay helper **902**. The packet can also include a payload (PL) **1015** and/or other fields having contents known to those of ordinary skill in the art.

The IP handler **314** of the source overlay helper **902** receives the packet from the end station **202**. The IP handler **314** adds an overlay encapsulation **1020** to the packet and outputs (**904**) the encapsulated packet to the source access switch. The overlay encapsulation **1020** includes an outer overlay MAC header **1017**, an outer overlay IP header **1018**, and an overlay header **1019**. The outer overlay MAC header **1017** includes a source MAC address (omac1) corresponding to the source access switch port and a next hop MAC address (rmac1). In an embodiment, if the target is in the same subnet as the source, then the destination MAC address is that of the destination overlay system **208**. In another embodiment, as shown in FIG. **2**, the destination MAC address is that of a router or gateway interface (R1) that routes packets between the subnets of the end stations **202**, **206**, respectively. The outer overlay IP header **1018** can include the IP address of the source overlay agent **904** and the IP address of the destination overlay agent. The overlay header **1019** can include a unique identifier that identifies the virtual network. When the overlay encapsulation **1020** is added to the packet received from the source end station **202**, the contents of the original packet **1013**, **1014**, **1015** are combined to form a new payload PL1 **1021**, which is output (**1016**) with the overlay encapsulation **1020** from the overlay helper **902** to the source access switch having the source overlay agent **904**, which in turn outputs (**1022**) the packet **1020**, **1021** to the router **210**, or to a network switch or related network device.

FIG. **11** is a schematic block diagram illustrating a process flow **1100** for communicating with a destination overlay system, in accordance with an embodiment. In describing the process flow **1100**, reference is also made to elements of FIGS. **1-10**. In particular, the process flow **1100** is described as occurring between the second end station **206**, the router **210** and the policy server of FIG. **2** and the destination overlay helper **304** implemented in the destination end station **206** (generally, **922**) and the destination overlay agent **302** implemented in the destination access switch (generally, **924**) of FIG. **9**. However, the process flow **1100** can equally apply between end stations and access switches referred to in FIGS. **6-8** or in other figures described herein.

The process flow 1100 begins with the router 210 outputting (1102) the packet payload PL1 1021, the overlay header 1019, and the outer overlay IP header 1018 provided in the process flow 1000 to the destination access switch having the overlay agent 924, which in turn outputs (1104) this packet data to the destination overlay header 922. A MAC address header 1103 is added which can include the source MAC address, i.e., the MAC address of the router interface or access switch port outputting (1102) the packet payload PL1 1021. The MAC address header 1103 also includes the MAC address of the destination overlay agent 924.

The destination overlay helper 304 can remove the overlay header 1019 from the received frame and determines the destination end station 206 from the inner IP destination, i.e., ES2 IP address 1014, in the packet payload PL1 1021 and/or the virtual network identifier in the header 1019. A MAC header 1107 is added that includes the destination end station MAC address, which can be provided to the overlay helper 302 during the initialization process described in FIG. 9. Accordingly, the original payload PL 1015 can be directed to the intended destination end station 206.

As will be appreciated by one skilled in the art, aspects of the present invention may be embodied as a system, method or computer program product. Accordingly, aspects of the present invention may take the form of an entirely hardware embodiment, an entirely software embodiment (including firmware, resident software, micro-code, etc.) or an embodiment combining software and hardware aspects that may all generally be referred to herein as a "circuit," "module" or "system." Furthermore, aspects of the present invention may take the form of a computer program product embodied in one or more computer readable medium(s) having computer readable program code embodied thereon.

Any combination of one or more computer readable medium(s) may be utilized. The computer readable medium may be a computer readable signal medium or a computer readable storage medium. A computer readable storage medium may be, for example, but not limited to, an electronic, magnetic, optical, electromagnetic, infrared, or semiconductor system, apparatus, or device, or any suitable combination of the foregoing. More specific examples (a non-exhaustive list) of the computer readable storage medium would include the following: an electrical connection having one or more wires, a portable computer diskette, a hard disk, a random access memory (RAM), a read-only memory (ROM), an erasable programmable read-only memory (EPROM or Flash memory), an optical fiber, a portable compact disc read-only memory (CD-ROM), an optical storage device, a magnetic storage device, or any suitable combination of the foregoing. In the context of this document, a computer readable storage medium may be any tangible medium that can contain, or store a program for use by or in connection with an instruction execution system, apparatus, or device.

A computer readable signal medium may include a propagated data signal with computer readable program code embodied therein, for example, in baseband or as part of a carrier wave. Such a propagated signal may take any of a variety of forms, including, but not limited to, electro-magnetic, optical, or any suitable combination thereof. A computer readable signal medium may be any computer readable medium that is not a computer readable storage medium and that can communicate, propagate, or transport a program for use by or in connection with an instruction execution system, apparatus, or device. Program code embodied on a computer readable medium may be transmitted using any appropriate

medium, including but not limited to wireless, wireline, optical fiber cable, RF, etc., or any suitable combination of the foregoing.

Computer program code for carrying out operations for aspects of the present invention may be written in any combination of one or more programming languages, including an object oriented programming language such as Java, Smalltalk, C++ or the like and conventional procedural programming languages, such as the "C" programming language or similar programming languages. The program code may execute entirely on the user's computer, partly on the user's computer, as a stand-alone software package, partly on the user's computer and partly on a remote computer or entirely on the remote computer or server. In the latter scenario, the remote computer may be connected to the user's computer through any type of network, including a local area network (LAN) or a wide area network (WAN), or the connection may be made to an external computer (for example, through the Internet using an Internet Service Provider).

Aspects of the present invention are described herein with reference to flowchart illustrations and/or block diagrams of methods, apparatus (systems) and computer program products according to embodiments of the invention. It will be understood that each block of the flowchart illustrations and/or block diagrams, and combinations of blocks in the flowchart illustrations and/or block diagrams, can be implemented by computer program instructions. These computer program instructions may be provided to a processor of a general purpose computer, special purpose computer, or other programmable data processing apparatus to produce a machine, such that the instructions, which execute via the processor of the computer or other programmable data processing apparatus, create means for implementing the functions/acts specified in the flowchart and/or block diagram block or blocks.

These computer program instructions may also be stored in a computer readable medium that can direct a computer, other programmable data processing apparatus, or other devices to function in a particular manner, such that the instructions stored in the computer readable medium produce an article of manufacture including instructions which implement the function/act specified in the flowchart and/or block diagram block or blocks. The computer program instructions may also be loaded onto a computer, other programmable data processing apparatus, or other devices to cause a series of operational steps to be performed on the computer, other programmable apparatus or other devices to produce a computer implemented process such that the instructions which execute on the computer or other programmable apparatus provide processes for implementing the functions/acts specified in the flowchart and/or block diagram block or blocks.

The flowchart and block diagrams in the Figures illustrate the architecture, functionality, and operation of possible implementations of systems, methods and computer program products according to various embodiments of the present invention. In this regard, each block in the flowchart or block diagrams may represent a module, segment, or portion of code, which comprises one or more executable instructions for implementing the specified logical function(s). It should also be noted that, in some alternative implementations, the functions noted in the block may occur out of the order noted in the figures. For example, two blocks shown in succession may, in fact, be executed substantially concurrently, or the blocks may sometimes be executed in the reverse order, depending upon the functionality involved. It will also be noted that each block of the block diagrams and/or flowchart illustration, and combinations of blocks in the block diagrams

17

and/or flowchart illustration, can be implemented by special purpose hardware-based systems that perform the specified functions or acts, or combinations of special purpose hardware and computer instructions.

While the invention has been shown and described with reference to specific embodiments, it should be understood by those skilled in the art that various changes in form and detail may be made therein without departing from the spirit and scope of the invention.

What is claimed is:

1. A method for overlaying a virtual network on a physical network in a data center environment, comprising:

arranging an overlay system in an overlay virtual network to include an overlay agent and an overlay helper;

implementing the overlay agent in an access switch at a first location of the physical network;

implementing the overlay helper in at least one end station at a second location of the physical network, the end station including a network interface to the physical network for communicating with the access switch; and

transmitting overlay parameters for an overlay encapsulation field in compliance with an in-band protocol between the overlay agent and the overlay helper, the overlay helper configured to output the overlay encapsulation field from the network interface of the end station to the access switch to a destination overlay system, wherein the at least one end station includes at least one virtualized end station and at least one non-virtualized end station that are part of the overlay virtual network.

2. The method of claim **1**, further comprising:

outputting a data packet from the end station; and instructing the overlay helper to add the overlay encapsulation field to a data packet received by the overlay helper from the end station.

3. The method of claim **2**, wherein the overlay encapsulation field is transmitted from the overlay helper to the overlay agent in compliance with the in-band protocol.

4. The method of claim **2**, wherein the overlay encapsulation field includes overlay parameters related to packet classification criteria and virtual network topology data.

5. The method of claim **1**, further comprising:

receiving by the overlay agent a data packet including an overlay encapsulation field;

outputting the data packet from the overlay agent to the overlay helper; and

determining by the overlay helper a destination end station from at least one of a virtual network identifier and destination address data in the overlay encapsulation field.

6. The method of claim **5**, wherein the destination end station is at least one of a physical end station and a virtual end station.

7. The method of claim **1**, wherein the end station includes a hypervisor, and wherein the overlay helper is implemented in a hypervisor network interface (NIC) driver or firmware of the end station.

8. The method of claim **1**, wherein the overlay helper is implemented in a Single-Root I/O Virtualization (SR IOV) NIC of the end station.

9. The method of claim **1**, wherein the overlay helper is implemented in an operating system NIC driver or firmware of the end station.

18

10. A method for communication in an overlay virtual network, comprising:

arranging a first overlay system to include an overlay agent implemented in a first access switch at a first location of a physical network and an overlay helper implemented in a first end station that is in communication with the first access switch and is at a second location of the physical network, and includes a network interface to the physical network for communication with the first access switch;

arranging a second overlay system to include an overlay agent implemented in a second access switch and an overlay helper implemented in a second end station that is in communication with the second access switch; and transmitting overlay parameters from the overlay agent of the first overlay system to the overlay helper of the first overlay system, the overlay parameters including data for transmitting a data packet from the network interface of the first end station to the second overlay system in communication with the second end station, wherein at least one of the first or second end stations includes at least one virtualized end station and at least one non-virtualized end station that are part of the overlay virtual network.

11. The method of claim **10**, further comprising:

transmitting the data packet from the first end station to the second access switch;

transmitting the data packet from the overlay agent implemented in the second access switch to the overlay helper implemented in the second end station; and

determining by the overlay helper of the second end station a destination end station from the overlay parameters.

12. The method of claim **10**, further comprising:

instructing the overlay helper of the first end station to add an overlay encapsulation field to the data packet.

13. The method of claim **12**, wherein the overlay encapsulation field is transmitted from the overlay helper of the first end station to the overlay agent of the first end station in compliance with an in-band protocol.

14. The method of claim **12**, wherein the overlay encapsulation field includes overlay parameters related to packet classification criteria and virtual network topology data.

15. The method of claim **10**, further comprising:

receiving by the overlay helper of the second end station the overlay encapsulation field; and

determining by the overlay helper a destination end station from at least one of a virtual network identifier and destination address data in the overlay encapsulation field.

16. The method of claim **10**, wherein at least one of the first and second end stations includes a hypervisor, and wherein the overlay helper is implemented in a hypervisor network interface (NIC) driver or firmware of the at least one of the first and second end stations.

17. The method of claim **10**, wherein at least one of the overlay helper of the first end station and the overlay helper of the second end station is implemented in a Single-Root I/O Virtualization (SR IOV) NIC.

18. The method of claim **10**, wherein at least one of the overlay helper of the first end station and the overlay helper of the second end station is implemented in at least one of an operating system NIC driver and firmware.

* * * * *

UNITED STATES PATENT AND TRADEMARK OFFICE
CERTIFICATE OF CORRECTION

PATENT NO. : 8,964,600 B2
APPLICATION NO. : 13/454840
DATED : February 24, 2015
INVENTOR(S) : Amitabha Biswas et al.

Page 1 of 2

It is certified that error appears in the above-identified patent and that said Letters Patent is hereby corrected as shown below:

In the Specification

Column 5:

- In Line 38, delete “212” and replace with “210”.

Column 5:

- In Line 42, delete “212” and replace with “210”.

Column 5:

- In Line 60, delete “206” and replace with “208”.

Column 5:

- In Line 61, delete “206” and replace with “208”.

Column 6:

- In Line 57, delete “providing” and replace with “provide”.

Column 7:

- In Line 22, delete “map” and replace with “maps”.

Column 9:

- In Line 12, delete “413” and replace with “415”.

Column 10:

- In Line 1, delete “classifier 312” and replace with “classifier 312B”.

Column 10:

- In Line 35, delete “12” and replace with “612”.

Signed and Sealed this
Twenty-fifth Day of April, 2017

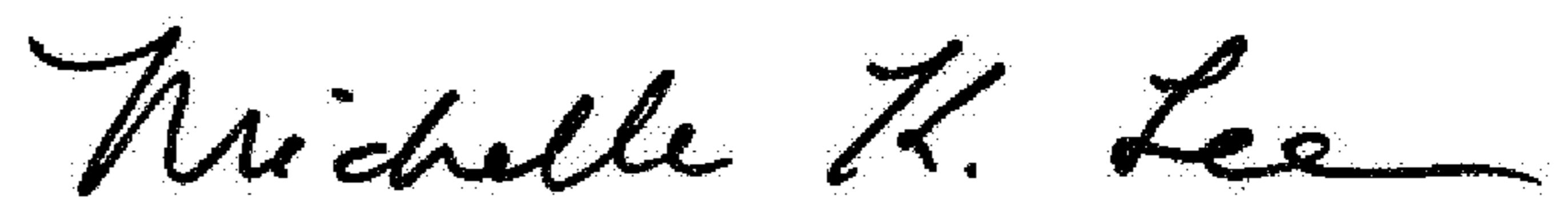

Michelle K. Lee
Director of the United States Patent and Trademark Office

CERTIFICATE OF CORRECTION (continued)
U.S. Pat. No. 8,964,600 B2

Column 11:

- In Line 14, after “physical card” insert --734--.

Column 11:

- In Line 25, delete “616” and replace with “716”.

Column 11:

- In Line 41, delete “12” and replace with “812”.

Column 13:

- In Line 8, delete “222” and replace with “922”.

Column 13:

- In Line 43, delete “FIG. 9” and replace with “FIG. 9A”.

Column 14:

- In Line 31, delete “(904)”.

Column 14:

- In Line 32, after “switch” insert --904--.

Column 14:

- In Line 65, delete “FIG. 9” and replace with “FIG. 9B”.

Column 15:

- In Line 20, delete “FIG. 9” and replace with “FIG. 9B”.