

US008951098B2

(12) **United States Patent**
Jhones

(10) **Patent No.:** **US 8,951,098 B2**
(45) **Date of Patent:** **Feb. 10, 2015**

(54) **ROTATABLE HAND-HELD
BLADE-SHARPENING APPARATUS**

(71) Applicant: **Spyderco, Inc.**, Golden, CO (US)

(72) Inventor: **Peter H. Jhones**, Wellington, CO (US)

(73) Assignee: **Spyderco, Inc.**, Golden, CO (US)

(*) Notice: Subject to any disclaimer, the term of this patent is extended or adjusted under 35 U.S.C. 154(b) by 116 days.

(21) Appl. No.: **13/691,032**

(22) Filed: **Nov. 30, 2012**

(65) **Prior Publication Data**

US 2014/0154963 A1 Jun. 5, 2014

(51) **Int. Cl.**

B24B 1/00 (2006.01)
B24B 3/54 (2006.01)
B24D 15/08 (2006.01)
B24D 15/06 (2006.01)
B24D 18/00 (2006.01)

(52) **U.S. Cl.**

CPC **B24D 15/06** (2013.01); **B24D 18/00** (2013.01)

USPC **451/45**; **451/552**

(58) **Field of Classification Search**

CPC B24B 3/54; B24B 3/52; B24B 21/002;
B24B 3/36; B24D 15/08; B24D 15/06
USPC 451/555, 552, 557, 45; 76/82, 86, 88
See application file for complete search history.

(56) **References Cited**

U.S. PATENT DOCUMENTS

D116,704 S 9/1939 Conway et al.
D142,880 S 11/1945 Loucony

D153,706 S 5/1949 Lathom
4,231,194 A 11/1980 Glesser
4,259,815 A * 4/1981 Kuban 451/557
4,450,653 A * 5/1984 Fletcher 451/552
4,640,058 A 2/1987 Glesser
D290,222 S 6/1987 Moody
4,696,129 A 9/1987 Roberts
4,719,722 A * 1/1988 Washburn 451/557
4,751,795 A 6/1988 Jenne
4,759,153 A 7/1988 Cohen
4,912,885 A 4/1990 Bonapace
D318,782 S 8/1991 LeBeau
D322,741 S 12/1991 Jenne
D326,989 S 6/1992 Button et al.
D327,402 S 6/1992 Button et al.
D328,847 S 8/1992 Button et al.
D333,081 S 2/1993 Glesser

(Continued)

FOREIGN PATENT DOCUMENTS

CA 1130567 8/1982
DE 3041584 6/1982
GB 2084058 4/1982

OTHER PUBLICATIONS

“Ceramic Stick Sharpener,” A.G. Russell Catalog, no date, cited by Examiner in Office Action for U.S. Appl. No. 29/082,235 mailed Aug. 12, 1998, p. 35.

(Continued)

Primary Examiner — Robert Rose

(74) Attorney, Agent, or Firm — Sheridan Ross P.C.

(57)

ABSTRACT

A sharpening apparatus is provided. The sharpening apparatus includes a foldable case, a first sharpening tool, and a second sharpening tool. The first and second sharpening tools are associated with the foldable case and are rotatable between a storage position and a sharpening position.

19 Claims, 8 Drawing Sheets

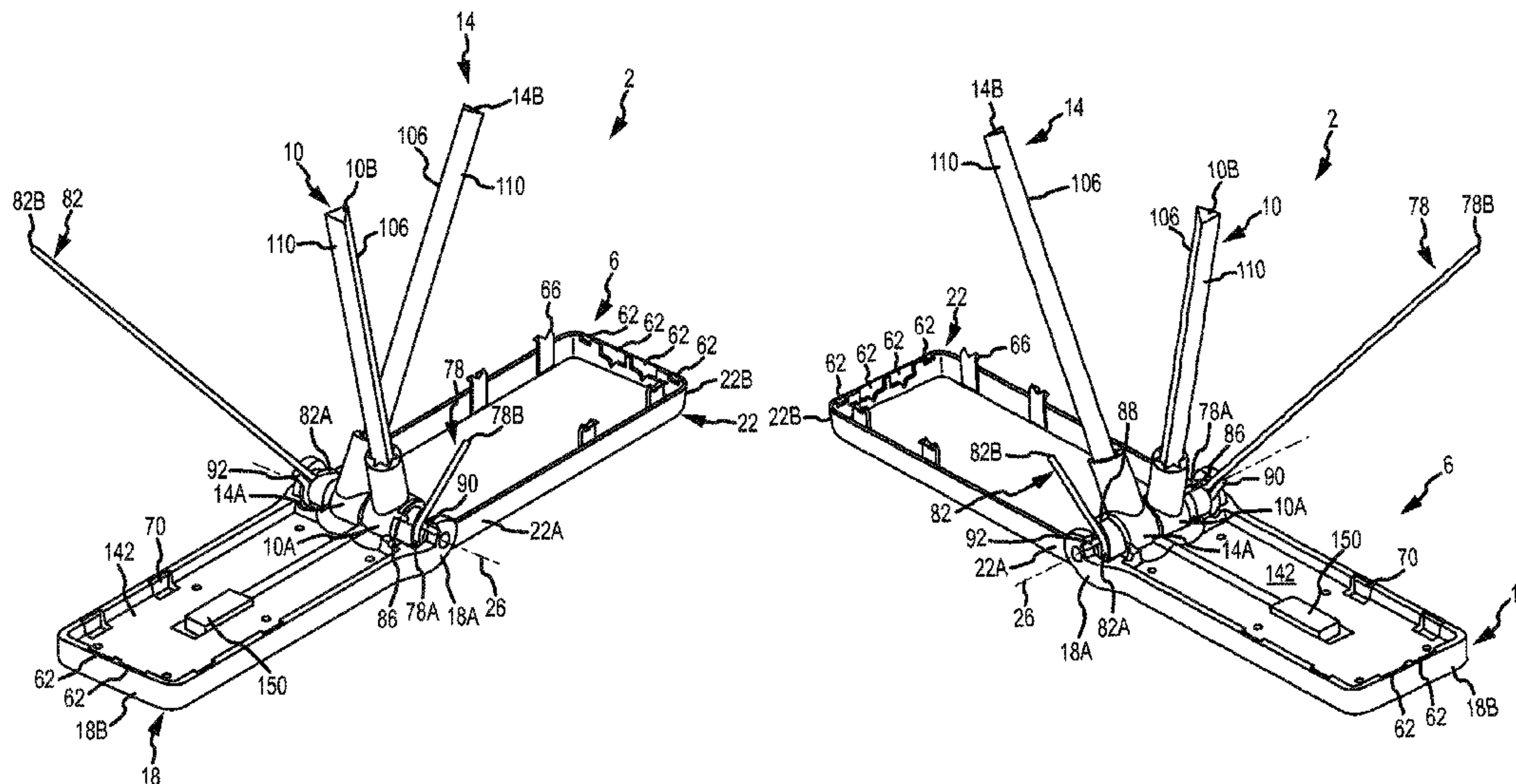

(56)

References Cited

U.S. PATENT DOCUMENTS

D337,253	S	7/1993	Glesser
D353,988	S	1/1995	Glesser
5,458,534	A	10/1995	Campione et al.
5,477,753	A	12/1995	Branscum et al.
D365,740	S	1/1996	Smith
D367,598	S	3/1996	Fortenberry
D369,081	S	4/1996	Byers et al.
D387,262	S	12/1997	Byers et al.
D394,596	S	5/1998	Byers et al.
D404,278	S	1/1999	Gore
D406,038	S	2/1999	Glesser
D427,500	S	7/2000	Glesser

OTHER PUBLICATIONS

“Lansky Crock Pack Sharpener,” Atlanta Cutlery Catalog, Spring 1996, p. 150.
Official Action for U.S. Appl. No. 29/082,235 mailed Aug. 12, 1998, 5 pages.
Notice of Allowance for U.S. Appl. No. 29/082,235 mailed Oct. 9, 1998, 3 pages.
Official Action for U.S. Appl. No. 29/103,288 mailed Aug. 26, 1999, 5 pages.
Notice of Allowance for U.S. Appl. No. 29/103,288 mailed Nov. 15, 1999, 3 pages.

* cited by examiner

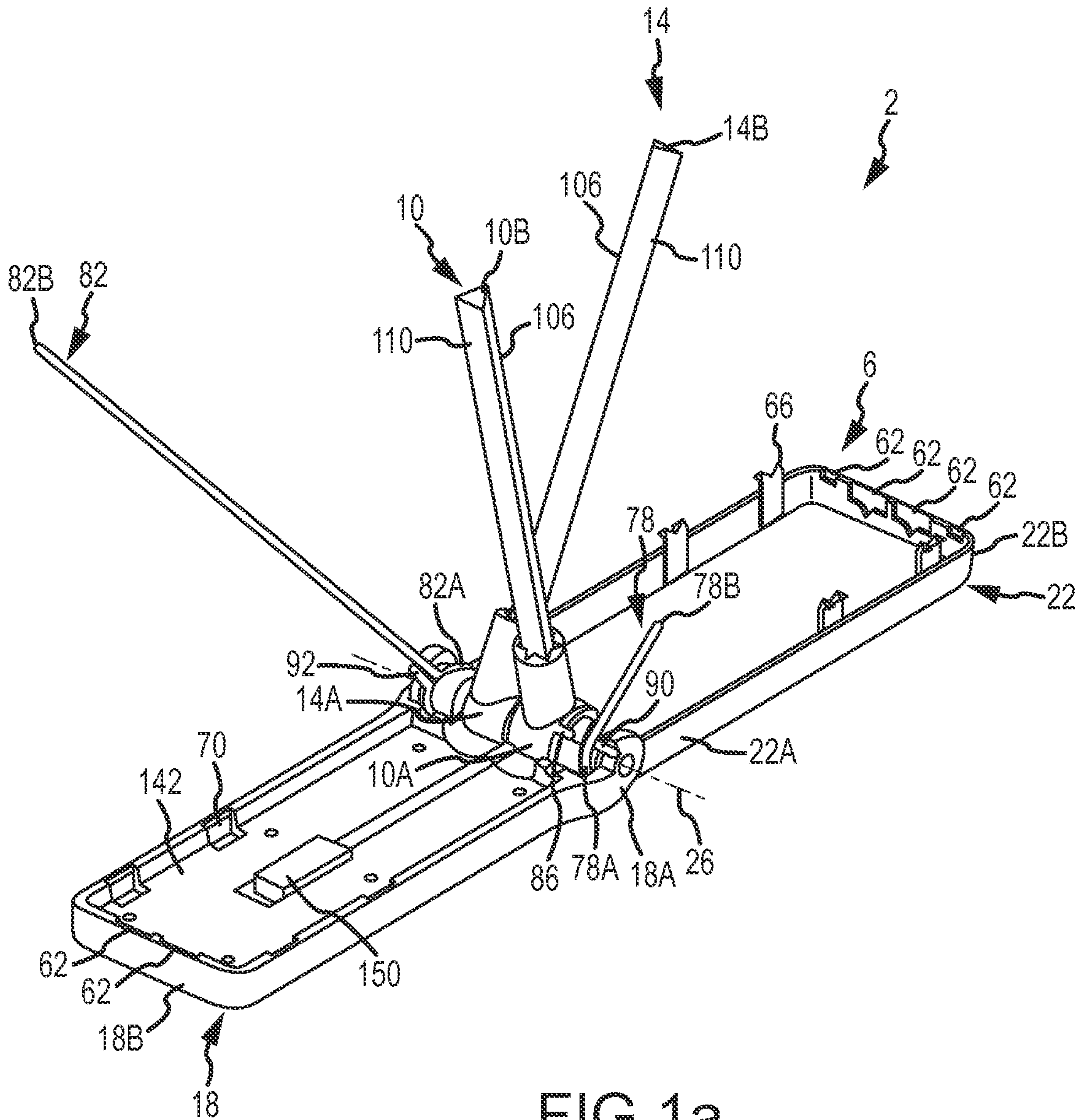

FIG. 1a

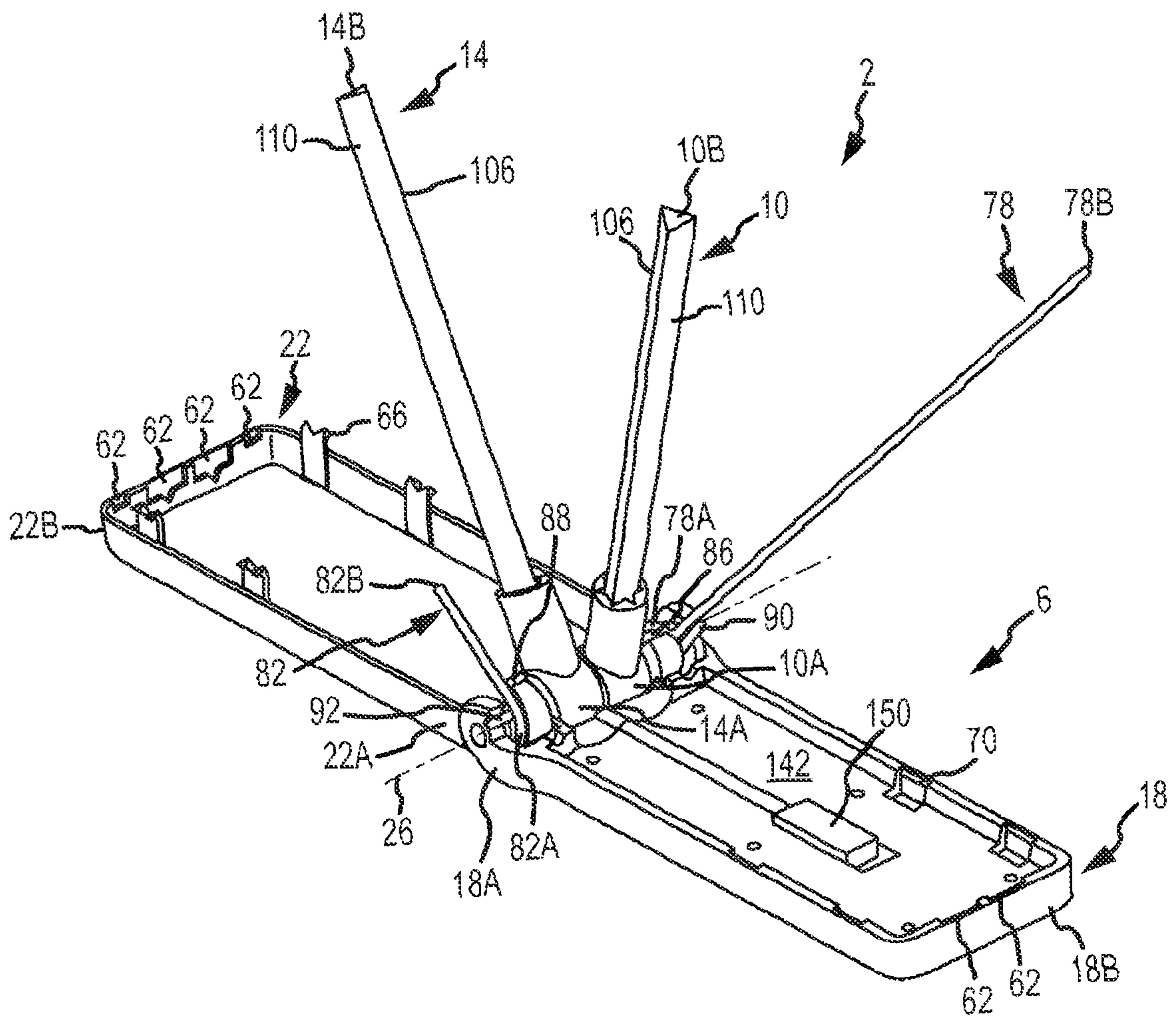

FIG. 1b

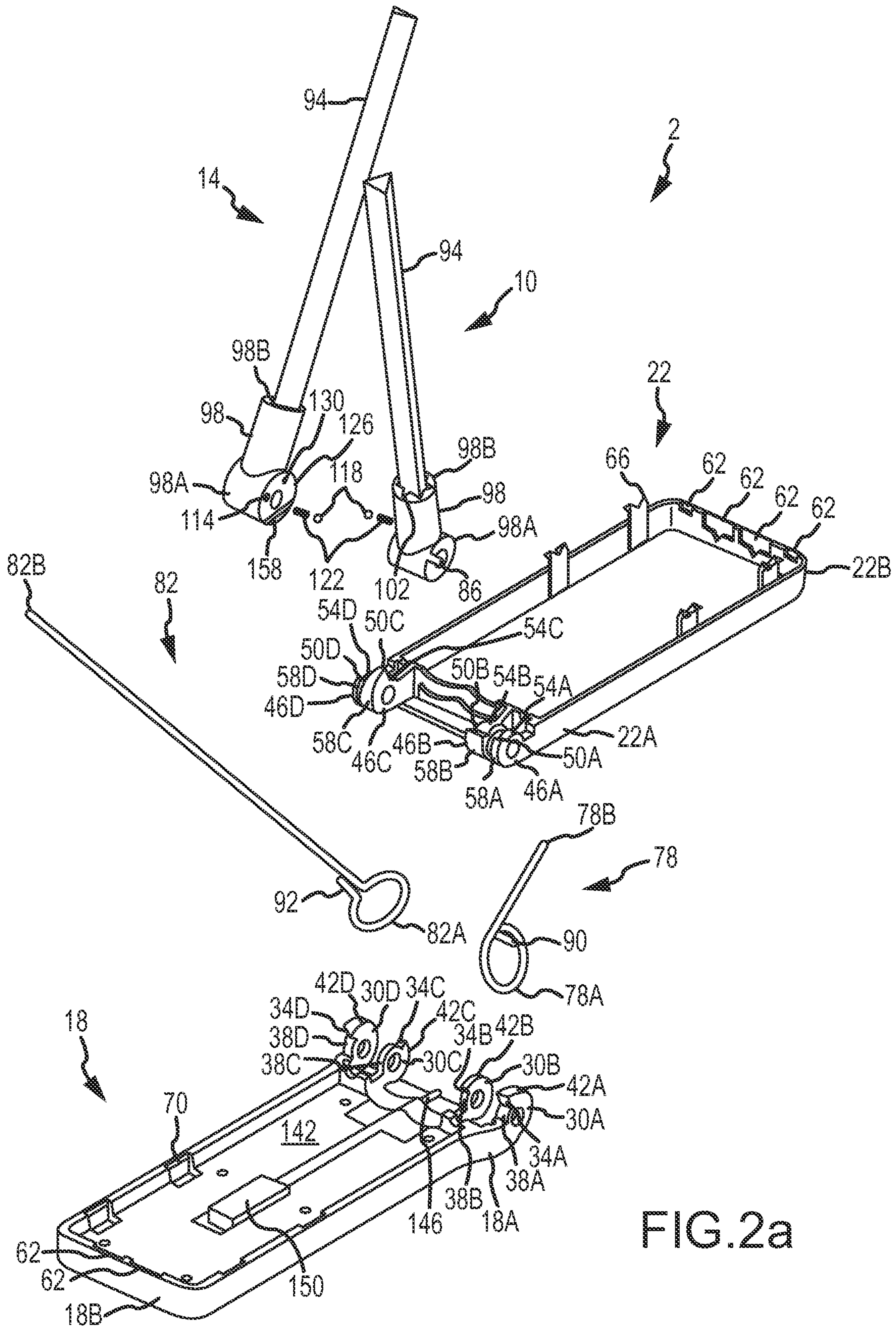

FIG.2a

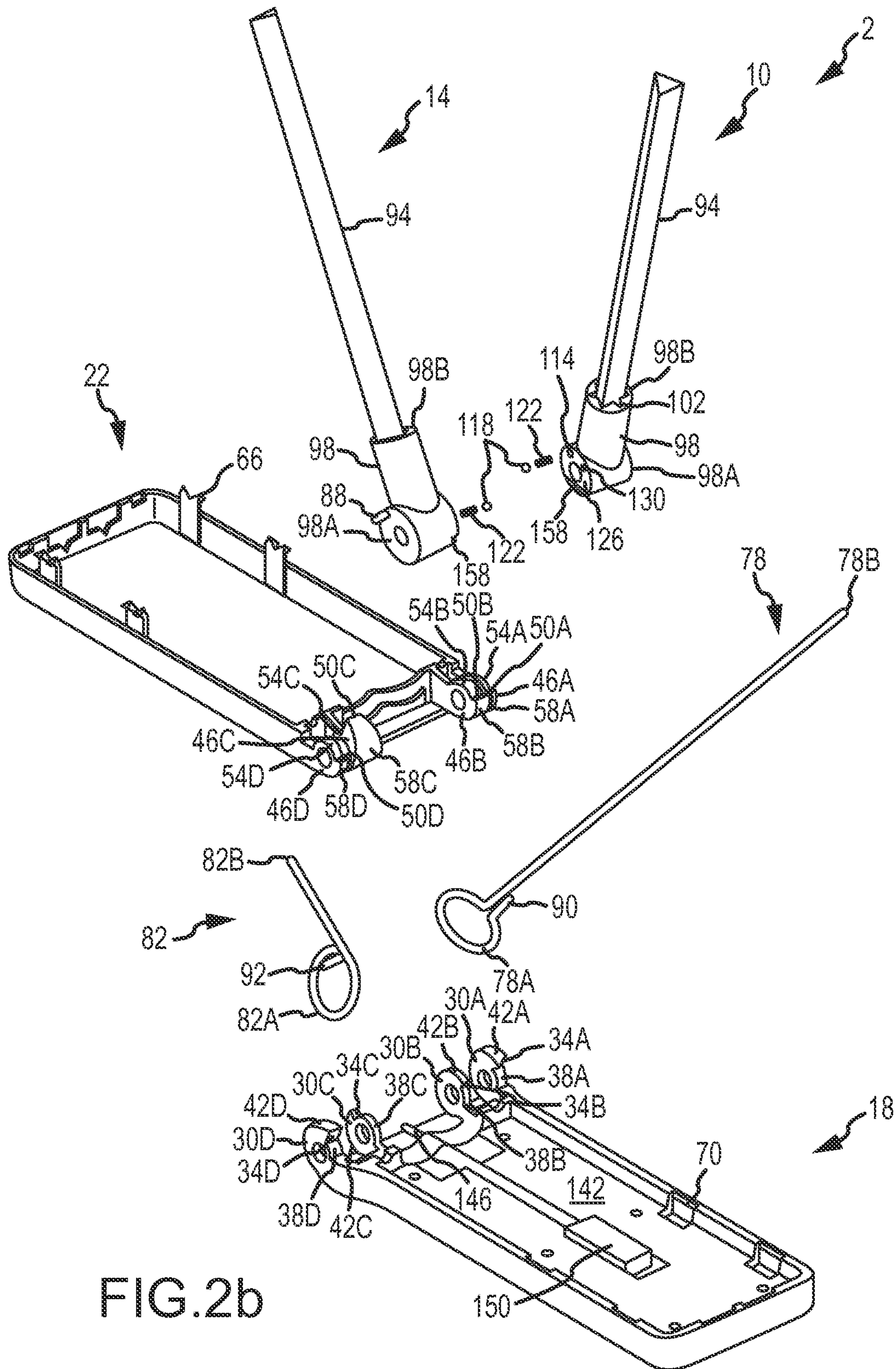

FIG. 2b

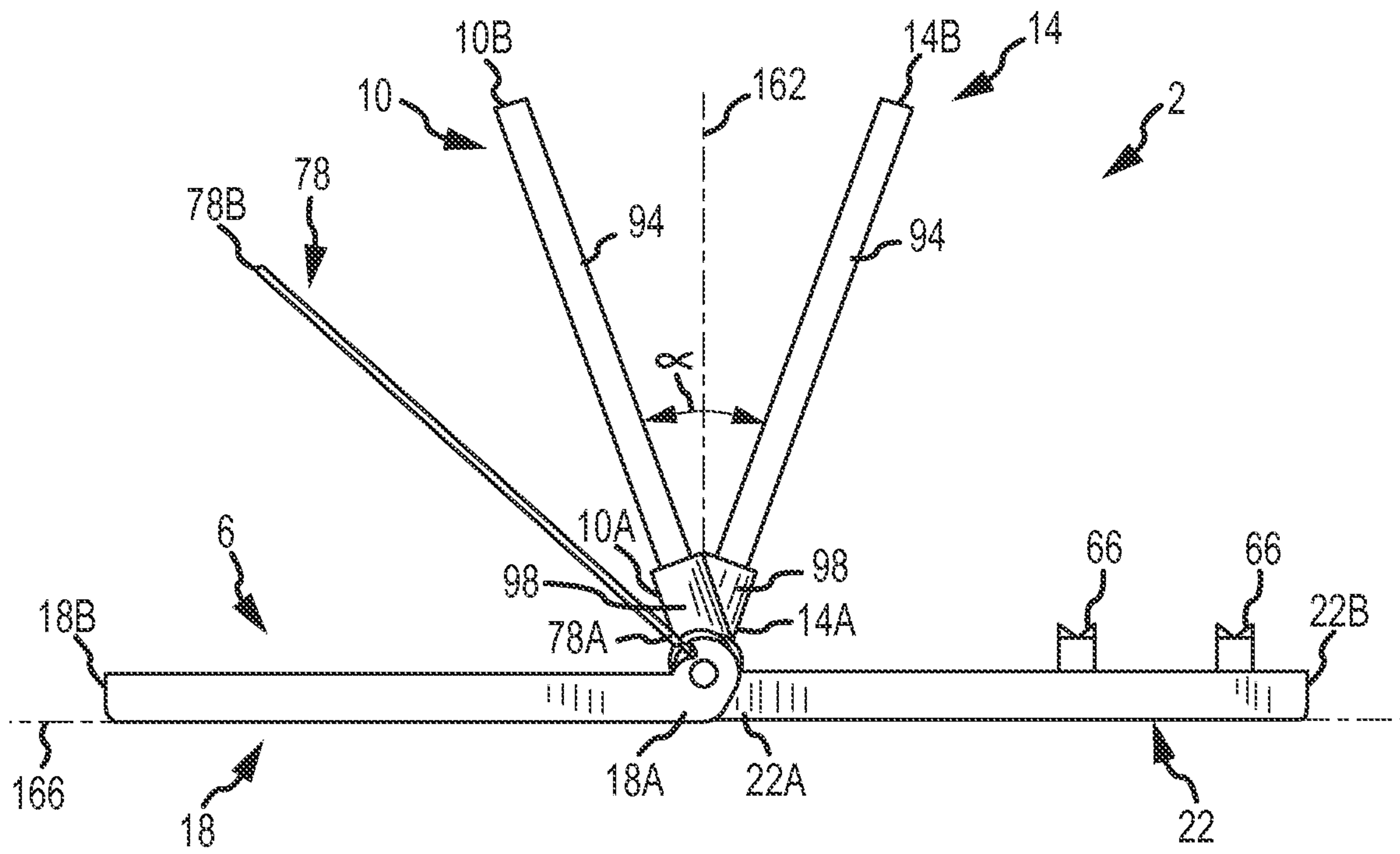

FIG. 3

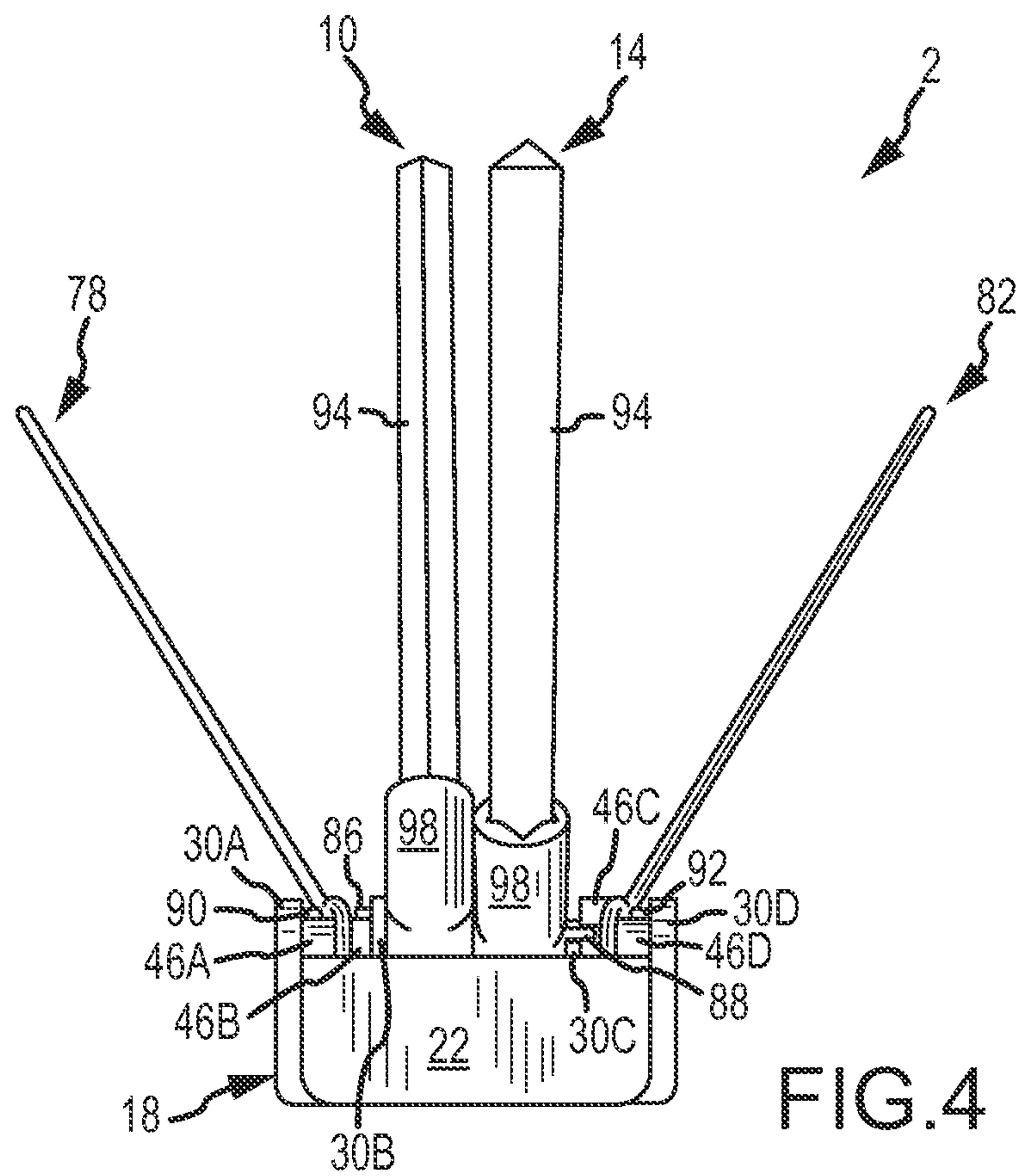

FIG. 4

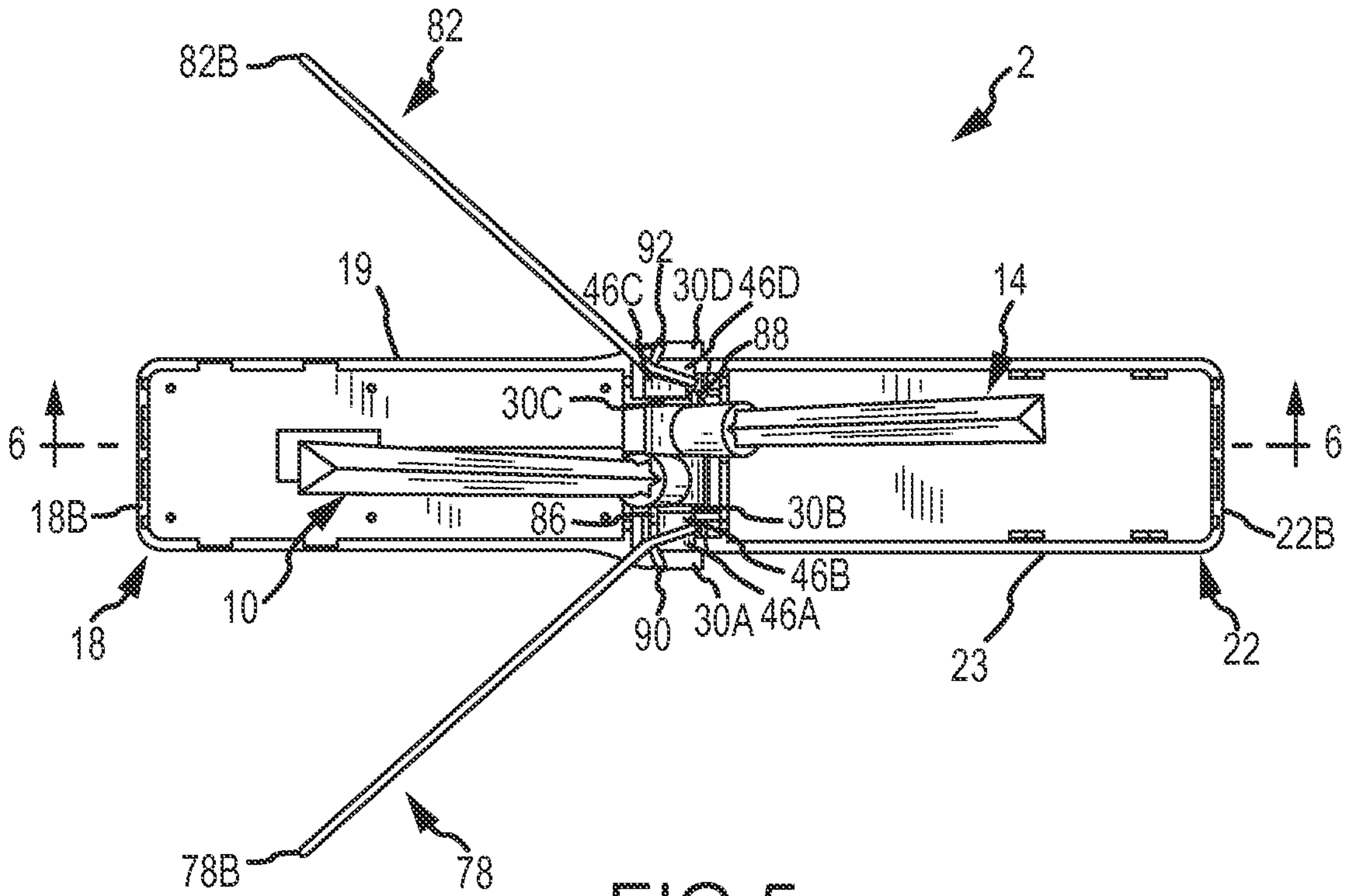

FIG. 5

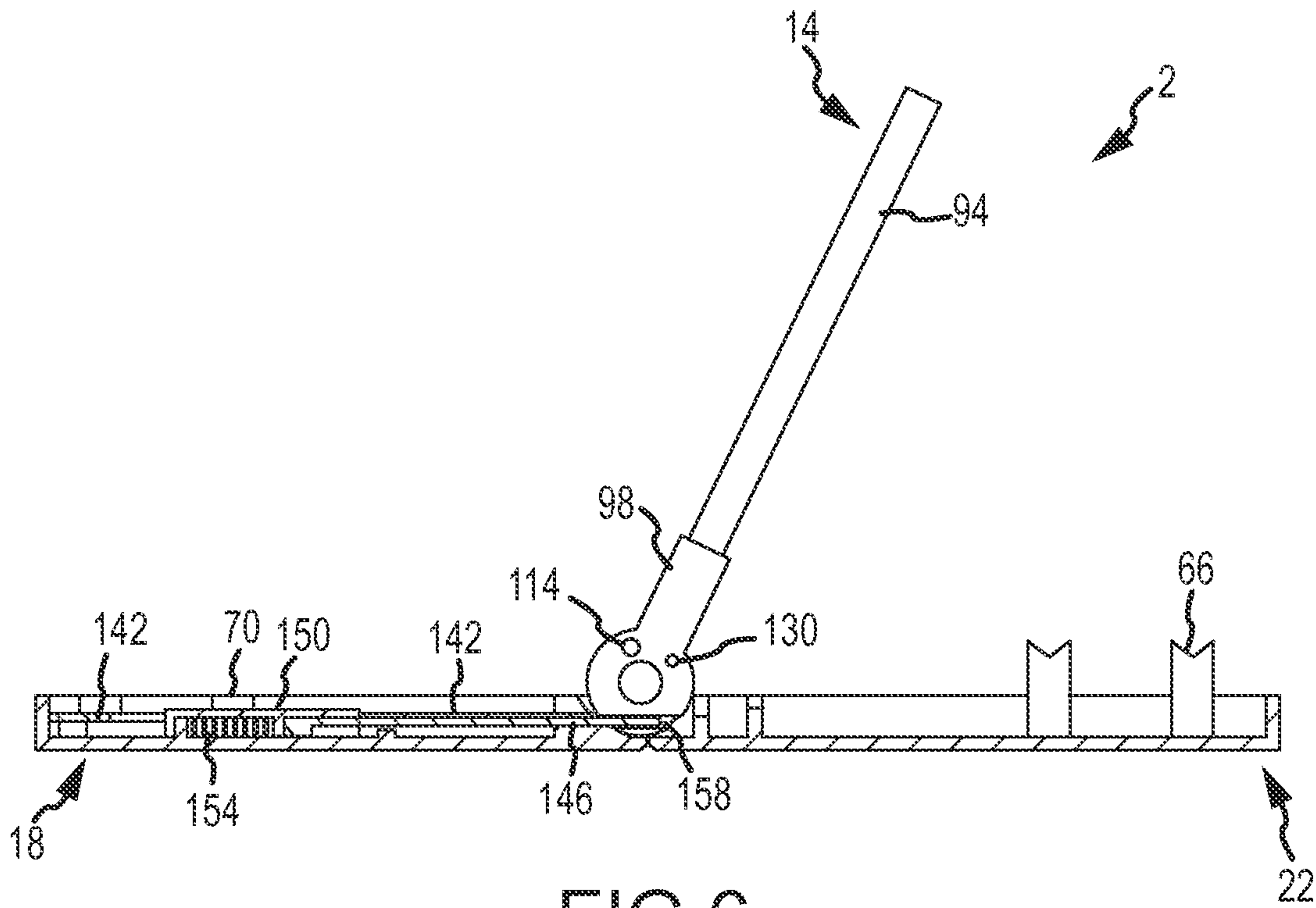

FIG. 6

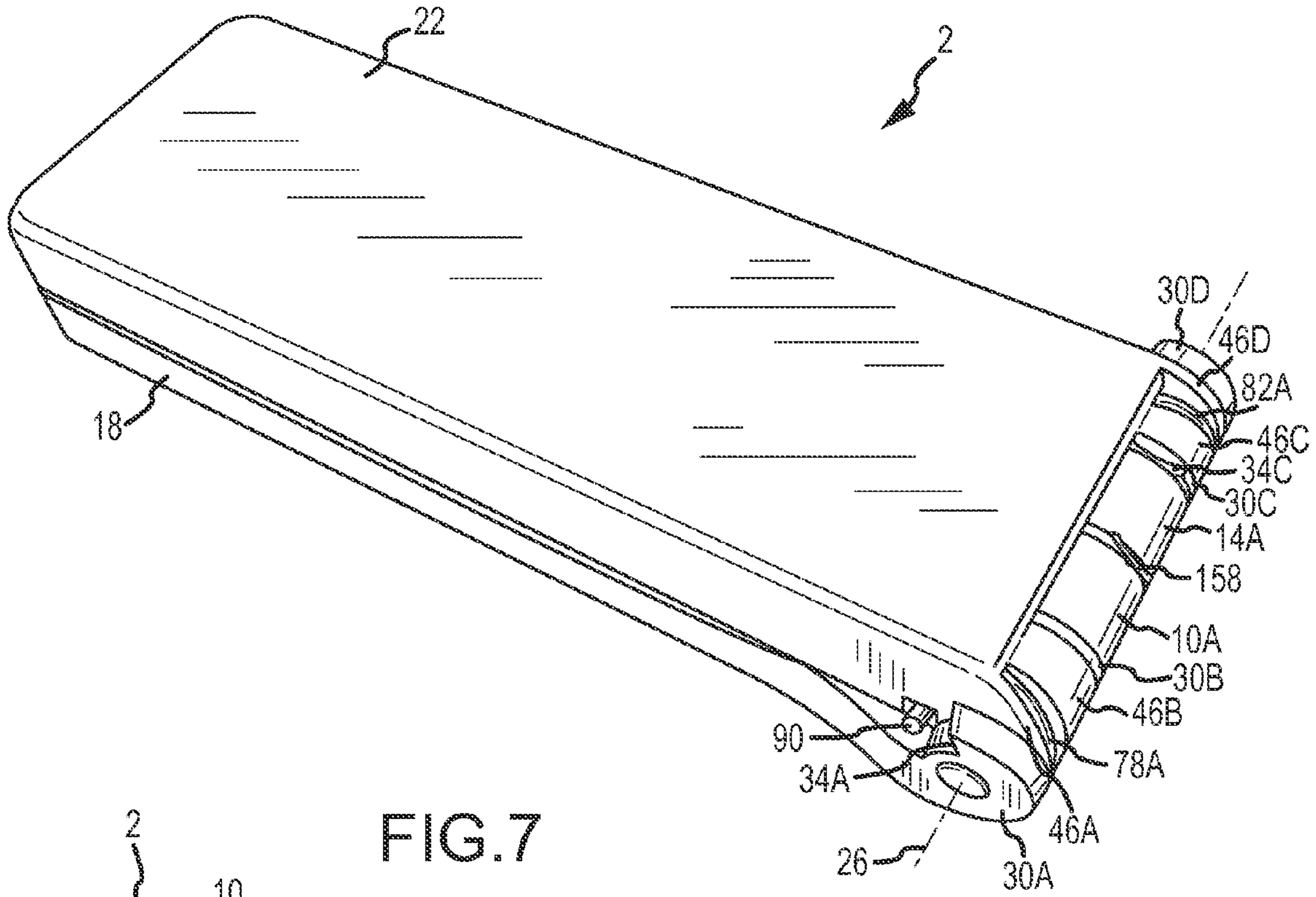

FIG. 7

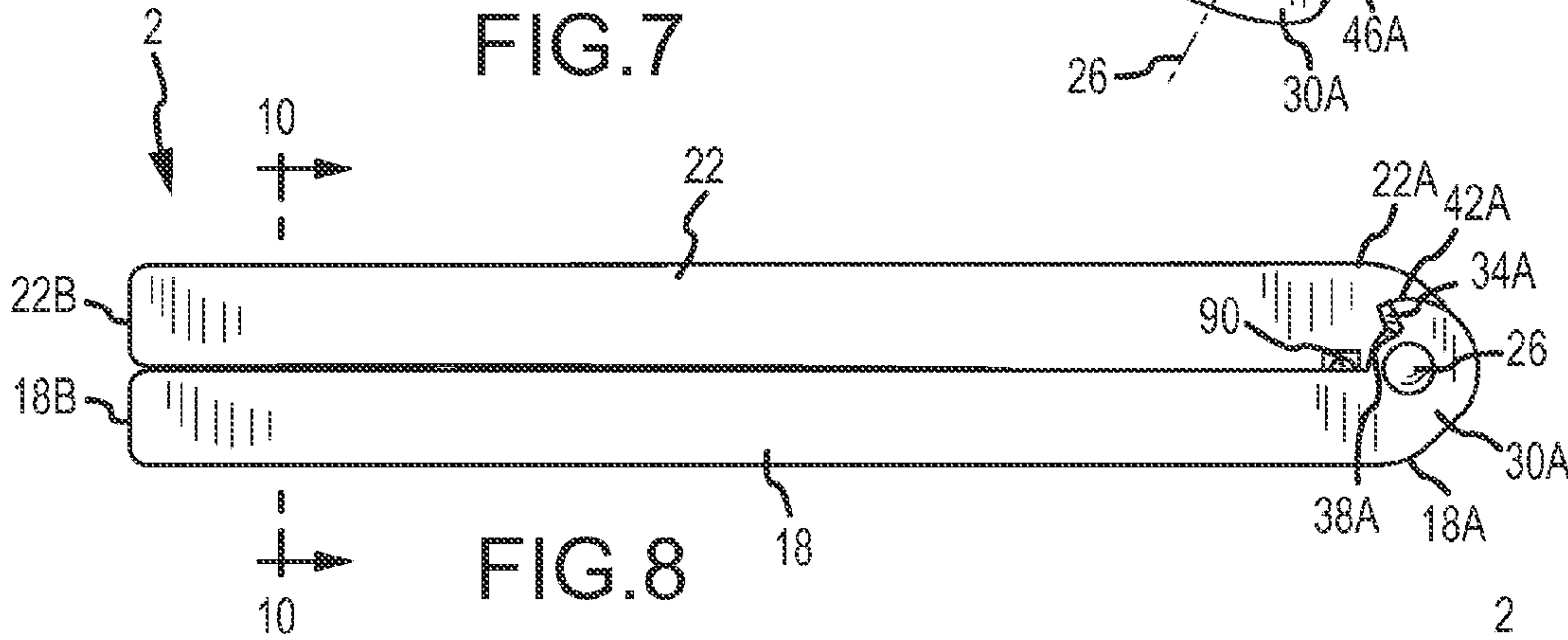

FIG. 8

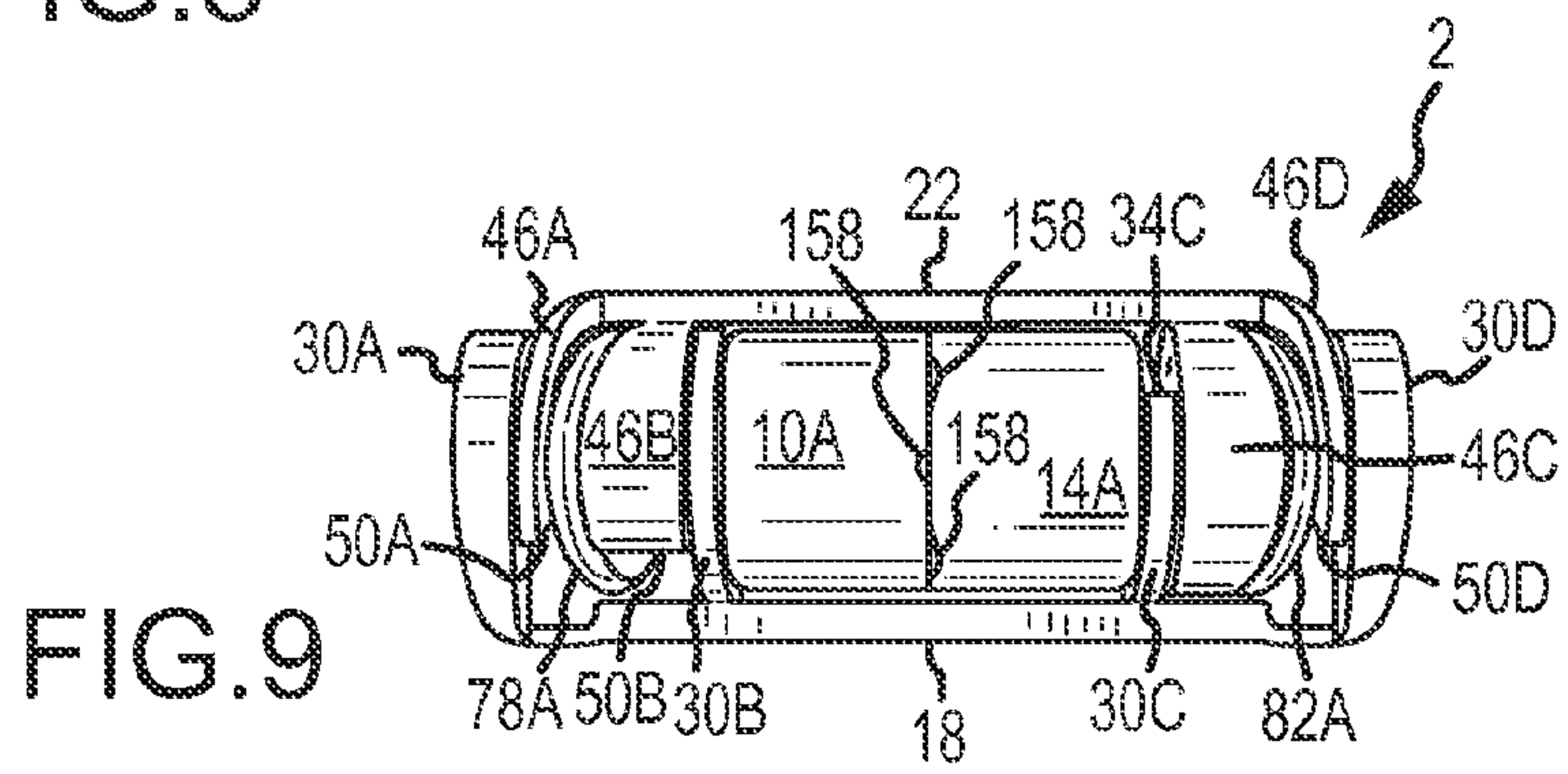

FIG. 9

1

ROTATABLE HAND-HELD BLADE-SHARPENING APPARATUS

FIELD OF THE INVENTION

Embodiments of the present invention generally relate to sharpening devices. More specifically, embodiments of the present invention relate to a rotatable, hand-held, blade-sharpening apparatus.

BACKGROUND OF THE INVENTION

Cutting tools, such as axes, chisels, knives, scissors, razors, and various lawn and garden tools, generally include a blade having at least one cutting edge that dulls after a period of use. To increase the effectiveness and possibly extend the life of the cutting tool, various types of sharpeners are available to sharpen a cutting edge. For example, grinding wheels, honing steels, sharpening stones, and razor strops are commonly utilized in sharpening, straightening, and/or polishing a cutting edge.

Many times a cutting tool is used in field applications and becomes dull. Commonly, the operator of the cutting tool does not have a sharpener or does not have the time and/or patience to assemble a portable sharpener. Despite the number of existing sharpeners utilized to sharpen a cutting edge, there is still a need for an improved sharpener that is compact, lightweight, and easy to use, thereby accommodating field applications.

SUMMARY OF THE INVENTION

Embodiments of the present invention generally relate to a rotatable hand-held blade-sharpening apparatus. The blade-sharpening apparatus generally includes a foldable case that is compact, lightweight, durable, and protects a sharpening mechanism positioned within the case. The sharpening mechanism may be utilized to form and/or sharpen a cutting edge.

It is one aspect of the present invention to provide a blade-sharpening apparatus utilizing a foldable case having a folded, or closed, position and an unfolded, or open, position of use. The foldable case may include a first cover plate rotatably interconnected to a second cover plate. In a folded position, the first cover plate and the second cover plate define an interior space that can accommodate at least one sharpening tool. The foldable case may include a closure mechanism to secure the foldable case in the folded position, which may include latches, straps, magnets, or other mechanisms now known or later developed in the art. In an unfolded position, the first cover plate and the second cover plate provide a base for the blade-sharpening apparatus. In one configuration, the first cover plate and the second cover plate lay flat in an unfolded position. The foldable case may include a locking mechanism to secure the foldable case in the unfolded position, which may include any locking device now known or later developed in the art. The foldable case generally may be constructed of metallic or non-metallic materials. For example, in one embodiment, the foldable case is constructed of a rigid plastic material.

It is another aspect of the present invention to provide a blade-sharpening apparatus utilizing at least one sharpening tool. The at least one sharpening tool may include a sharpening stone, a sharpening, or honing steel, or any other sharpening tool now known or later developed in the art. In one embodiment, the at least one sharpening tool comprises a sharpening rod which may have a circular, triangular, square,

2

or other cross-section shape now known or later developed in the art. The at least one sharpening tool can be constructed of various materials including steel, diamond particles, ceramics such as silicon carbide or aluminum oxide, or other sharpening materials now known or later developed in the art. The at least one sharpening tool can be constructed of various grits including ultra-fine, fine, medium, coarse, or other grits now known or later developed in the art. The at least one sharpening tool also may include a furrow running the length of each tool which is utilized to sharpen pointed items like fishhooks, darts, broadheads, and awls.

It is another aspect of the present invention to provide a blade-sharpening apparatus utilizing at least one sharpening tool that is rotatable between a storage position and a sharpening position. In one embodiment, a first and a second sharpening tool are rotatable to preset angles in which the first and second sharpening tools are positioned at a predetermined angle relative to each other. The predetermined angle can include any range of angles that are utilized to sharpen and/or form a cutting edge. The predetermined sharpening angle eliminates guesswork in the field and provides a precision edge every time. In one embodiment, the predetermined angle is adjustable between a range of angles. If more than one sharpening tool is provided, each sharpening tool may rotate about a common axis of rotation or about separate axes of rotation. The at least one sharpening tool may be lockable in the storage and/or sharpening position.

It is another aspect of the present invention to provide a blade-sharpening apparatus that includes at least one sharpening tool that automatically rotates to a predetermined sharpening position upon opening of a foldable case. In one embodiment, the rotation of a first sharpening tool and of a second sharpening tool about an axis of rotation is coupled to the rotation of a first cover plate and/or a second cover plate. In this embodiment, rotation of the first cover plate or the second cover plate from a folded position to an unfolded position rotates the first sharpening tool and the second sharpening tool from their respective storage positions to their respective sharpening positions, providing a sharpener that is fast and easy to use, especially in field applications.

It is another aspect of the present invention to provide a blade-sharpening apparatus that includes at least one hand guard that protects a user's hands from a cutting edge of a blade or tool while sharpening. The at least one hand guard may be rotatable between a storage position and a guard position, and may be lockable in the guard position. The rotation of the at least one hand guard may be coupled to the rotation of a first cover plate and/or a second cover plate to provide a sharpener that is safe, fast, and easy to use, especially in field applications. The at least one hand guard may be constructed of metallic or non-metallic materials. For example, in one embodiment, the at least one hand guard is a rod constructed of brass.

To assure that a user places their hand in the correct position under the hand guards, the opposing folding cover may have one or more barbs or projections extending from an interior surface to dissuade a user from placing their hand on that portion of the sharpening apparatus. These barbs may be mere extensions of the latch pins which are used to secure the first cover plate to the second cover plate in a closed position, or more aggressive projections to impart discomfort to a user.

It is another aspect of the present invention to provide a blade-sharpening apparatus, comprising:

a foldable case positionable between a folded and an unfolded position;

a first sharpening tool having a first end and a second end, the first end of the first sharpening tool interconnected to the

3

case, the first sharpening tool rotatable between a storage position and a sharpening position, the rotation of the first sharpening tool coupled to the positioning of the case; and

a second sharpening tool having a first end and a second end, the first end of the second sharpening tool interconnected to the case, the second sharpening tool rotatable between a storage position and a sharpening position, the rotation of the second sharpening tool coupled to the positioning of the case.

It is another aspect of the present invention to provide a blade-sharpening apparatus, comprising:

a first cover plate having a first end and a second end;

a second cover plate having a first end and a second end, the first end of the second cover plate interconnected to at least one of the first end of the first cover plate or a hinge mechanism, at least one of the first or second cover plates rotatable between a folded and an unfolded position;

a first holder having a first end and a second end, the first end of the first holder interconnected to at least one of the first cover plate, the second cover plate, or a hinge mechanism, the first holder rotatable between a storage position and a sharpening position;

a first sharpening rod removably interconnected to the second end of the first holder;

a second holder having a first end and a second end, the first end of the second holder interconnected to at least one of the first cover plate, the second cover plate, or a hinge mechanism, the second holder rotatable between a storage position and a sharpening position; and

a second sharpening rod removably interconnected to the second end of the second holder.

It is another aspect of the present invention to provide a method of assembling a foldable blade-sharpening apparatus, comprising:

providing a foldable case configured to rotate between a folded and an unfolded position, a first sharpening tool having a first end and a second end, and a second sharpening tool having a first end and a second end;

interconnecting the first end of the first sharpening tool to the foldable case so that the first sharpening tool is rotatable between a first position of storage and a second position of sharpening;

interconnecting the first end of the second sharpening tool to the foldable case so that the second sharpening tool is rotatable between a first position of storage and a second position of sharpening; and

coupling the rotation of the first and second sharpening tools to the rotation of the foldable case, wherein the first and second sharpening tools are oriented in a substantially common plane in the first position of storage and oriented in two distinct planes, each at a predetermined angle, in the second position of sharpening.

The method may further comprise providing a first and second hand guard each having a first end and a second end, interconnecting the first end of the first hand guard to the foldable case so that the first hand guard is rotatable between a first position of storage and a second position of use, and interconnecting the first end of the second hand guard to the foldable case so that the second hand guard is rotatable between a first position of storage and a second position of use. The first and second hand guards may be coupled to rotate to a common plane when the foldable case is moved from an unfolded position to a folded position.

It is another aspect of the present invention to provide a method of positioning a blade-sharpening apparatus into a sharpening position, comprising:

providing a blade-sharpening apparatus comprising:

a first cover plate having a first end and a second end;

4

a second cover plate having a first end and a second end, the first end of the second cover plate rotatably interconnected to the first end of the first cover plate;

a first sharpening tool having a first end and a second end, the first end of the first sharpening tool rotatably interconnected to the first ends of the first and second cover plates, wherein the first sharpening tool is rotatable between a first position of storage and a second position of sharpening; and

a second sharpening tool having a first end and a second end, the first end of the second sharpening tool rotatably interconnected to the first ends of the first and second cover plates, wherein the second sharpening tool is rotatable between a first position of storage and a second position of sharpening, and wherein when rotated to the second position of sharpening, the first and second sharpening tools are positioned at a predetermined angle relative to each other; and

rotating the first cover plate or the second cover plate from the folded position to the unfolded position, wherein rotation of the first or second cover plate rotates the first and second sharpening tools from their respective storage positions to their respective sharpening positions. When in the unfolded position, the first and second cover plates may form a base oriented in a substantially horizontal plane

It is another aspect of the present invention that the hand guards rotate outwardly during opening of the first and second cover plates, and thus extend outwardly from the perimeter edges of the first and second cover plates. In one embodiment, this outward rotation is created by a unique geometric configuration in the knuckles of the hand guards.

The phrases “at least one”, “one or more”, and “and/or”, as used herein, are open-ended expressions that are both conjunctive and disjunctive in operation. For example, each of the expressions “at least one of A, B and C”, “at least one of A, B, or C”, “one or more of A, B, and C”, “one or more of A, B, or C” and “A, B, and/or C” means A alone, B alone, C alone, A and B together, A and C together, B and C together, or A, B and C together.

The term “a” or “an” entity, as used herein, refers to one or more of that entity. As such, the terms “a” (or “an”), “one or more” and “at least one” can be used interchangeably herein.

The use of “including,” “comprising,” or “having” and variations thereof herein is meant to encompass the items listed thereafter and equivalents thereof as well as additional items. Accordingly, the terms “including,” “comprising,” or “having” and variations thereof are open-ended and can be used interchangeably herein.

It shall be understood that the term “means” as used herein shall be given its broadest possible interpretation in accordance with 35 U.S.C., Section 112, Paragraph 6. Accordingly, a claim incorporating the term “means” shall cover all structures, materials, or acts set forth herein, and all of the equivalents thereof. Further, the structures, materials or acts and the equivalents thereof shall include all those described in the summary of the invention, brief description of the drawings, detailed description, abstract, and claims themselves.

The Summary is neither intended nor should it be construed as being representative of the full extent and scope of embodiments of the present invention. Embodiments of the present invention are set forth in various levels of detail in the Summary as well as in the attached drawings and the Detailed Description and no limitation as to the scope of the claimed subject matter is intended by either the inclusion or non-inclusion of elements, components, etc. in this Summary. Moreover, reference made herein to “the present invention” or aspects thereof should be understood to mean certain

embodiments of the present invention and should not necessarily be construed as limiting all embodiments to a particular description.

BRIEF DESCRIPTION OF THE DRAWINGS

The accompanying drawings, which are incorporated in and constitute a part of the specification, illustrate embodiments of the disclosure and together with the general description given above and the detailed description of the drawings given below, serve to explain the principles of these embodiments.

FIG. 1a is a perspective view of one embodiment of a blade-sharpening apparatus in an unfolded position;

FIG. 1b is another perspective view of the blade-sharpening apparatus shown in FIG. 1a in an unfolded position;

FIG. 2a is an exploded perspective view of the blade-sharpening apparatus shown in FIG. 1a;

FIG. 2b is an exploded perspective view of the blade-sharpening apparatus shown in FIG. 1b;

FIG. 3 is a front elevation view of the blade-sharpening apparatus shown in FIG. 1;

FIG. 4 is a right-side elevation view of the blade-sharpening apparatus shown in FIG. 1 without latch members;

FIG. 5 is a top plan view of the blade-sharpening apparatus shown in FIG. 1;

FIG. 6 is cross-section view taken along line 6-6 of the blade-sharpening apparatus shown in FIG. 5;

FIG. 7 is a perspective view of the blade-sharpening apparatus shown in FIG. 1 in a folded position;

FIG. 8 is front elevation view of the blade-sharpening apparatus shown in FIG. 7;

FIG. 9 is a right-side elevation view of the blade-sharpening apparatus shown in FIG. 7; and

FIG. 10 is a cross-section view taken along line 10-10 of the blade-sharpening apparatus shown in FIG. 7.

It should be understood that the drawings are not necessarily to scale. In certain instances, details that are not necessary for an understanding of the disclosure or that render other details difficult to perceive may have been omitted. It should be understood, of course, that the claimed invention is not necessarily limited to the particular embodiments illustrated herein.

To assist in the understanding of the drawings, the following is a list of components and associated numbering found in the drawings:

#	Components
2	Blade-sharpening apparatus
6	Foldable case
10	First sharpening tool
10A	First end of first sharpening tool
10B	Second end of first sharpening tool
14	Second sharpening tool
14A	First end of second sharpening tool
14B	Second end of second sharpening tool
18	First cover plate
18A	First end of first cover plate
18B	Second end of first cover plate
19	Perimeter edge of first cover plate
22	Second cover plate
22A	First end of second cover plate
22B	Second end of second cover plate
23	Perimeter edge of second cover plate
26	Axis of rotation
30A	First knuckle of first cover plate
30B	Second knuckle of first cover plate
30C	Third knuckle of first cover plate

-continued

#	Components
30D	Fourth knuckle of first cover plate
34A	Contact surface of first knuckle of first cover plate
34B	Contact surface of second knuckle of first cover plate
34C	Contact surface of third knuckle of first cover plate
34D	Contact surface of fourth knuckle of first cover plate
38A	Radially-inward exterior surface of first knuckle of first cover plate
38B	Radially-inward exterior surface of second knuckle of first cover plate
38C	Radially-inward exterior surface of third knuckle of first cover plate
38D	Radially-inward exterior surface of fourth knuckle of first cover plate
42A	Radially-outward exterior surface of first knuckle of first cover plate
42B	Radially-outward exterior surface of second knuckle of first cover plate
42C	Radially-outward exterior surface of third knuckle of first cover plate
42D	Radially-outward exterior surface of fourth knuckle of first cover plate
46A	First knuckle of second cover plate
46B	Second knuckle of second cover plate
46C	Third knuckle of second cover plate
46D	Fourth knuckle of second cover plate
50A	Contact surface of first knuckle of second cover plate
50B	Contact surface of second knuckle of second cover plate
50C	Contact surface of third knuckle of second cover plate
50D	Contact surface of fourth knuckle of second cover plate
54A	Radially-inward exterior surface of first knuckle of second cover plate
54B	Radially-inward exterior surface of second knuckle of second cover plate
54C	Radially-inward exterior surface of third knuckle of second cover plate
54D	Radially-inward exterior surface of fourth knuckle of second cover plate
58A	Radially-outward exterior surface of first knuckle of second cover plate
58B	Radially-outward exterior surface of second knuckle of second cover plate
58C	Radially-outward exterior surface of third knuckle of second cover plate
58D	Radially-outward exterior surface of fourth knuckle of second cover plate
62	Receptacles
66	Protruding latch members
70	Latch receptacles
78	First hand guard
78A	First end of first hand guard
78B	Second end of first hand guard
82	Second hand guard
82A	First end of second hand guard
82B	Second end of second hand guard
86	Tab of first sharpening tool
88	Tab of second sharpening tool
90	Tab of first hand guard
92	Tab of second hand guard
94	Sharpening rod
98	Holder
98A	First end of holder
98B	Second end of holder
102	Keyed slots
106	Corner of sharpening rod
110	Flat side of sharpening rod
114	Cavity
118	Ball
122	Spring
126	Side surface of holder
130	Recess in side surface of holder
134	Locking mechanism
138	Fasteners
142	Cap plate
146	Slidable rod
146A	First end of slidable rod
146B	Second end of slidable rod
150	Finger grip

-continued

#	Components
154	Spring
158	Groove
162	Vertical plane
166	Horizontal plane

DETAILED DESCRIPTION

Referring to FIGS. 1-10, embodiments of a blade-sharpening apparatus 2 are provided. The blade-sharpening apparatus 2 generally includes a foldable case 6, a first sharpening tool 10 having a first end 10A rotatably interconnected to the foldable case 6, and a second sharpening tool 14 having a first end 14A rotatably interconnected to the foldable case 6. The foldable case 6 may include a first cover plate 18 rotatably interconnected to a second cover plate 22. In the depicted embodiments, the first sharpening tool 10, the second sharpening tool 14, the first cover plate 18, and the second cover plate 22 are rotatably interconnected about a common axis of rotation 26. However, in alternative embodiments, the blade-sharpening apparatus 2 may include multiple rotation axes. For example, in one alternative embodiment, each rotatable component rotates about a unique axis of rotation.

With reference to FIGS. 1-2, one embodiment of a blade-sharpening apparatus 2 in an unfolded position is depicted. The blade-sharpening apparatus 2 includes a foldable case 6 having a first cover plate 18 rotatably interconnected to a second cover plate 22 about an axis of rotation 26. In addition, a first sharpening tool 10 and a second sharpening tool 14 are rotatably interconnected to the first cover plate 18 and the second cover plate 22 about the axis of rotation 26.

The first cover plate 18 has a first end 18A and a second end 18B. The first end 18A of the first cover plate 18 includes a plurality of knuckles 30A, 30B, 30C, 30D, each of which generally comprises a hollow cylinder configured to accommodate a pivot pin. As illustrated in FIGS. 2A-2B, the knuckles 30A, 30B, 30C, 30D are generally separated from each other along the axis of rotation 26. In addition, each knuckle 30A, 30B, 30C, 30D has a contact surface 34A, 34B, 34C, 34D that is formed between a radially-inward exterior surface 38A, 38B, 38C, 38D and a radially-outward exterior surface 42A, 42B, 42C, 42D, respectively. The contact surfaces 34A, 34B, 34C, 34D are formed in the knuckles 30A, 30B, 30C, 30D, respectively, at predetermined angles about the axis of rotation 26. As illustrated, the outermost knuckles 30A, 30D each include a contact surface 34A, 34D, respectively, which are formed at approximately equal angles about the axis of rotation 26, whereas the innermost knuckles 30B, 30C each include a contact surface 34B, 34C, respectively, which are formed at differing angles about the axis of rotation 26 relative to each other. The purpose of the contact surfaces 34A, 34B, 34C, 34D will be discussed below.

Similar to the first cover plate 18, the second cover plate 22 has a first end 22A and a second end 22B. The first end 22A of the second cover plate 22 includes a plurality of knuckles 46A, 46B, 46C, 46D, each of which generally comprises a hollow cylinder configured to accommodate a pivot pin. As illustrated in FIGS. 2A-2B, the knuckles 46A, 46B, 46C, 46D are generally separated from each other along the axis of rotation 26. In addition, each knuckle 46A, 46B, 46C, 46D has a contact surface 50A, 50B, 50C, 50D that is formed between a radially-inward exterior surface 54A, 54B, 54C, 54D and a radially-outward exterior surface 58A, 58B, 58C, 58D,

respectively. The contact surfaces 50A, 50B, 50C, 50D are formed in the knuckles 46A, 46B, 46C, 46D, respectively, at predetermined angles about the axis of rotation 26. As illustrated, the outermost knuckles 46A, 46D each include a contact surface 50A, 50D, respectively, which are formed at approximately equal angles about the axis of rotation 26, whereas the innermost knuckles 46B, 46C each include a contact surface 50B, 50C, respectively, which are formed at differing angles relative to each other about the axis of rotation 26. The purpose of the contact surfaces 50A, 50B, 50C, 50D will be discussed below.

When assembled, the knuckles 46A, 46B of the second cover plate 22 are positioned between the knuckles 30A, 30B of the first cover plate 18, and the knuckles 46C, 46D of the second cover plate 22 are positioned between the knuckles 30C, 30D of the first cover plate 18. In this configuration, the first end 22A of the second cover plate 22 can be rotatably interconnected to first end 18A of the first cover plate 18 about the axis of rotation 26 by inserting a pivot pin through the knuckles 30A, 30B, 30C, 30D of the first cover plate 18 and the knuckles 46A, 46B, 46C, 46D of the second cover plate 22.

The first cover plate 18 and the second cover plate 22 may have at least one receptacle 62 configured to receive a first sharpening tool 10 and/or a second sharpening tool 14 when the blade-sharpening apparatus 2 is in a folded position. For example, as illustrated, receptacles 62 are formed in the first end 18A and the second end 18B of the first cover plate 18, as well as in the first end 22A and the second end 22B of the second cover plate 22. The receptacles 62 in the second ends 18B, 22B of the first cover plate 18 and the second cover plate 22, respectively, may be configured to receive various sharpening tools, including triangular and circular cross-sections.

The blade-sharpening apparatus 2 also may include a latch mechanism configured to join the first cover plate 18 and the second cover plate 22 together when in a closed position, while allowing for the cover plates 18, 22 to be separated from each other upon application of a predetermined amount of force. As illustrated, the first cover plate 18 includes a plurality of protruding latch members 66 configured to engage corresponding latch receptacles 70 formed in the second cover plate 22. Upon closure of the foldable case 6, each protruding latch member 66 contacts a corresponding latch receptacle 70 and elastically deforms until the protruding latch member 66 snaps into a corresponding latch receptacle 70. To open the case 6 from a closed position, a predetermined amount of force is applied to the first cover plate 18 and/or second cover plate 22, which elastically deforms each protruding latch member 66 to allow the first cover plate 18 to separate from the second cover plate 22. The number of latch members can be varied. For example, in one embodiment, only one protruding latch member and one corresponding latch receptacle are utilized. Also, the placement of the protruding latch member 66 and the latch receptacle 70 can be varied. For example, the first cover plate 18 may include a protruding latch member 66 and/or a latch receptacle 70, and similarly the second cover plate 22 may include a protruding latch member 66 and/or a latch receptacle 70.

Still referring to FIGS. 1-2, the blade-sharpening apparatus 2 includes a plurality of sharpening tools rotatably interconnected to the foldable case 6. In particular, a first sharpening tool 10 has a first end 10A rotatably interconnected to the first end 18A of the first cover plate 18 and to the first end 22A of the second cover plate 22 about the axis of rotation 26, which may be accomplished by use of a pivot pin, and a second end 10B. A second sharpening tool 14 has a first end 14A rotatably interconnected to the first end 18A of the first cover plate

18 and to the first end 22A of the second cover plate 22 about the axis of rotation 26, which may be accomplished by use of a pivot pin, and a second end 14B. The number of sharpening tools can vary. For example, in one alternative embodiment, only one sharpening tool is included in the blade-sharpening apparatus. In another alternative embodiment, a plurality of sharpening tools is included in the blade-sharpening apparatus, which may include three or more sharpening tools.

The first sharpening tool 10 and the second sharpening tool 14 are rotatable between a storage position, shown in FIG. 10, and a sharpening position, shown in FIGS. 1 and 3-5. When rotated to the sharpening position, the first sharpening tool 10 and the second sharpening tool 14 are positioned at a predetermined angle relative to each other. The predetermined angle between the first sharpening tool 10 and the second sharpening tool 14 may be altered based on the desired sharpening angle of the edge of the blade. In one embodiment, the predetermined angle may be preset between 0 degrees and about 90 degrees. For example, common predetermined angles include about 20 degrees for very sharp edges, about 30 degrees for typical knife edges, about 40 degrees or more for tough edges such as that used to chop, and about 60 degrees for extremely durable edges such as chisels or drawknives. As another example, a common predetermined angle for scissors is about 25 degrees. In one specific embodiment, sharpening tools 10, 14 are preset at about 90 degrees relative to each other, or about 45 degrees relative to a vertical plane passing through an axis of rotation 26.

Each blade-sharpening apparatus 2 may be preset to a particular predetermined angle and thus tailored for specific applications. For example, if the predetermined angle is preset at 30 degrees, the first sharpening tool 10 would have a sharpening position that is 15 degrees counterclockwise from a vertical plane passing through the axis of rotation 26, and the second sharpening tool 14 would have a sharpening position that is 15 degrees clockwise from the vertical plane. Alternatively, a blade-sharpening apparatus 2 may include an adjustable predetermined angle, discussed in more detail below, for any angle between a predetermined range. For example, in one embodiment, a blade sharpening apparatus 2 includes sharpening tools that can be adjusted between about 20 to about 90 degrees relative to each other, or between about 10 to about 45 degrees relative to a vertical plane passing through the axis of rotation 26.

The blade-sharpening apparatus 2 also may include at least one hand guard. In FIGS. 1-2, the blade-sharpening apparatus 2 includes a first hand guard 78 and a second hand guard 82. The first hand guard 78 and the second hand guard 82 each have a first end 78A, 82A rotatably interconnected to the first end 18A of the first cover plate 18 and to the first end 22A of the second cover plate 22 about the axis of rotation 26, which may be accomplished by use of a pivot pin, and a second end 78B, 82B. The first hand guard 78 and the second hand guard 82 are rotatable between a storage position, shown in FIG. 10, and a guard position, shown in FIGS. 1 and 3-5. When rotated to the guard position, the first hand guard 78 and the second hand guard 82 are positioned at approximately the same predefined angle relative the first cover plate 18 and the first rotatable tool 10. Similar to the predetermined angle of the sharpening tools, the predefined angle of the hand guards may be preset to a particular angle or adjustable. Generally, the hand guards 78, 82 protect a user's hand while sharpening. In one embodiment, a blade sharpening apparatus 2 includes hand guards 78, 82 that can be preset between about 30 to about 150 degrees relative to each other, or between about 15 to about 75 degrees relative to a vertical plane passing through the axis of rotation 26. In one specific embodiment, hand

guards 78, 82 are preset at about 106 degrees relative to each other, or about 53 degrees relative to a vertical plane passing through the axis of rotation 26.

The rotation of the first sharpening tool 10, the second sharpening tool 14, the first hand guard 78, and/or the second hand guard 82 about the axis of rotation 26 may be coupled to the rotation of the first cover plate 18 and the second cover plate 22. For example, rotation of the first cover plate 18 or the second cover plate 22 from a folded position to an unfolded position may rotate the first sharpening tool 10 and the second sharpening tool 14 from their respective storage positions to their respective sharpening positions. Similarly, rotation of the first cover plate 18 or the second cover plate 22 from a folded position to an unfolded position may rotate the first hand guard 78 and the second hand guard 82 from their respective storage positions to their respective guard positions. Further, rotation of the first cover plate 18 or second cover plate 22 from an unfolded to a folded position may rotate the first sharpening tool 10, second sharpening tool 14, first hand guard 78, and/or second hand guard 82 to their respective storage positions, as shown in FIG. 10.

Still referring to FIGS. 1-2, the first end 10A of the first sharpening tool 10 and the first end 14A of the second sharpening tool 14 may each include a tab 86 that extends generally parallel to the axis of rotation 26. The tab 86 formed on the first end 10A of the first sharpening tool 10 is configured to interact with the contact surface 34B formed in the second knuckle 30B of the first cover plate 18 and/or the contact surface 50B formed in the second knuckle 46B of the second cover plate 22. The tab 86 formed on the first end 14A of the second sharpening tool 14 is configured to interact with the contact surface 34C formed in the third knuckle 30C of the first cover plate 18 and/or the contact surface 50C formed in the third knuckle 46C of the second cover plate 22.

In operation, if the second cover plate 22 is rotated about the axis of rotation 26 to unfold the foldable case 6 from a folded position to an unfolded position, the contact surface 50B formed in the second knuckle 46B of the second cover plate 22 contacts the tab 86 formed on the first end 10A of the first sharpening tool 10, and the contact surface 50C formed in the third knuckle 46C of the second cover plate 22 contacts the tab 88 formed on the first end 14A of the second sharpening tool 14, and the contact surfaces 50B, 50C rotate the first sharpening tool 10 and the second sharpening tool 14, respectively, to their sharpening positions. Similarly, if the first cover plate 18 is rotated about the axis of rotation 26 to unfold the foldable case 6 from a folded, or closed, position, to an unfolded position, the contact surface 34B formed in the second knuckle 30B of the first cover plate 18 contacts the tab 86 formed on the first end 10A of the first sharpening tool 10, and the contact surface 34C formed in the third knuckle 30C of the first cover plate 18 contacts the tab 88 formed on the first end 14A of the second sharpening tool 14, and the contact surfaces 34B, 34C rotate the first sharpening tool 10 and the second sharpening tool 14, respectively, to their sharpening positions.

When the foldable case 6 is in the unfolded position, the contact surfaces 34B, 50B formed in the second knuckles 30B, 46B of the first cover plate 18 and the second cover plate 22, respectively, contact opposing sides of the tab 86 formed in the first end 10A of the first sharpening tool 10 to lock the first sharpening tool 10 in a sharpening position. Similarly, the contact surfaces 34C, 50C formed in the third knuckles 30C, 46C of the first cover plate 18 and the second cover plate 22, respectively, contact opposing sides of the tab 88 formed in the first end 14A of the second sharpening tool 14 to lock the second sharpening tool 14 in a sharpening position. By

11

altering the angle of the contact surfaces about the axis of rotation 26, the sharpening angle of the first sharpening tool 10 and of the second sharpening tool 14 can be altered. In one embodiment, the contact surfaces are adjustable about the axis of rotation 26. For example, the contact surfaces may be formed as part of telescopic members that telescopically extend about the axis of rotation 26. The telescopic members may be lockable at predetermined angles. In one configuration, the telescopic members include marks that correspond to predetermined sharpening angles to assist a user in selecting a sharpening angle for the first sharpening tool 10 and the second sharpening tool 14.

Still referring to FIGS. 1-2, the first end 78A of the first hand guard 78 and the first end 82A of the second hand guard 82 each include a tab 90, 92, respectively, that generally extends along the axis of rotation 26. The tab 90 formed on the first end 78A of the first hand guard 78 is configured to interact with the contact surface 34A formed in the first knuckle 30A of the first cover plate 18 and/or the contact surface 50A formed in the first knuckle 46A of the second cover plate 22. The tab 92 formed on the first end 82A of the second hand guard 82 is configured to interact with the contact surface 34D formed in the fourth knuckle 30D of the first cover plate 18 and/or the contact surface 50D formed in the fourth knuckle 46D of the second cover plate 22.

In operation, if the second cover plate 22 is rotated about the axis of rotation 26 to unfold the foldable case 6 from a folded position, to an unfolded position, the contact surface 50A formed in the first knuckle 46A of the second cover plate 22 contacts the tab 90 formed on the first end 78A of the first hand guard 78, and the contact surface 50D formed in the fourth knuckle 46D of the second cover plate 22 contacts the tab 92 formed on the first end 82A of the second hand guard 82, and the contact surfaces 50A, 50D rotate the first hand guard 78 and the second hand guard 82, respectively, to their guard positions. Similarly, if the first cover plate 18 is rotated about the axis of rotation 26 to unfold the foldable case 6 from a folded position to an unfolded position, the contact surface 34A formed in the first knuckle 30A of the first cover plate 18 contacts the tab 90 formed on the first end 78A of the first hand guard 78, and the contact surface 34D formed in the fourth knuckle 30D of the first cover plate 18 contacts the tab 92 formed on the first end 82A of the second hand guard 82, and the contact surfaces 34A, 34D rotate the first hand guard 78 and the second hand guard 82, respectively, to their guard positions.

When the foldable case 6 is in the unfolded position, the contact surfaces 34A, 50A formed in the first knuckles 30A, 46A of the first cover plate 18 and the second cover plate 22, respectively, contact opposing sides of the tab 90 formed in the first end 78A of the first hand guard 78 to lock the first hand guard 78 in a guard position. Similarly, the contact surfaces 34D, 50D formed in the fourth knuckles 30D, 46D of the first cover plate 18 and the second cover plate 22, respectively, contact opposing sides of the tab 92 formed in the first end 82A of the second hand guard 82 to lock the second hand guard 82 in a guard position. By altering the angle of the contact surfaces about the axis of rotation 26, the guard angle of the first hand guard 78 and the second hand guard 82 can be altered. Similar to the contact surfaces corresponding to the sharpening tools, the contact surfaces corresponding to the hand guards may be adjustable about the axis of rotation 26.

Referring to FIGS. 1-5, the first sharpening tool 10 and the second sharpening tool 14 may each comprise a sharpening rod 94 removably interconnected to a holder 98. Each holder 98 has a first end 98A rotatably interconnected to the first end 18A of the first cover plate 18 and to the first end 22A of the

12

second cover plate 22 about the axis of rotation 26. In addition, each holder 98 has a second end 98B configured to receive an end of a sharpening rod 94. In FIGS. 1-5, the sharpening rods 94 each have a triangular cross-section. In alternative embodiments, the sharpening rods 94 may have circular or other cross-sections now known or later developed in the art. In FIGS. 1-5, the second end 98B of each holder 98 includes predetermined geometry, or keyed slots 102, adapted to receive and selectively orient a sharpening rod 94. The keyed slots 102 allow triangular sharpening rods 94 to be selectively oriented about their longitudinal axis. For example, as illustrated, each sharpening rod 94 is oriented in the keyed slots 102 such that a corner 106 faces inward. In this orientation, serrated edges of a blade can be sharpened. Alternatively, each sharpening rod 94 may be oriented in the keyed slots 102 such that a flat side 110 faces inward. In this alternative orientation, plain edges of a blade can be sharpened. In one embodiment, each holder 98 may include slots that are angled relative to the axis of rotation 26 to further allow a user to alter the sharpening angle of each sharpening rod 94.

Referring to FIGS. 1-2 and 6, the first sharpening tool 10 and the second sharpening tool 14 may be lockable in a sharpening position. As previously discussed, the knuckles of the first cover plate 18 and the second cover plate 22 may include features that lock the first sharpening tool 10 and the second sharpening tool 14 in their respective sharpening positions. In addition, each holder 98 may house a ball detent in a cavity 114 formed in the first end 98A of each holder 98. If provided, a ball 118 is interconnected to a spring 122, and the spring 122 and ball 118 are placed in the cavity 114 such that a portion of the ball 118 protrudes out of the cavity 114. When assembled, the ball 118 contacts a side surface 126 of an adjacent holder 98, compresses the spring 122, and is retracted into the cavity 114. The ball 118 remains refracted in the cavity 114 until the first sharpening tool 10 and the second sharpening tool 14 are rotated into their sharpening positions, at which point a recess 130 formed in the side surface 126 of the adjacent holder 98 aligns with the cavity 114, allowing the spring 122 to expand and position a portion of the ball 118 in the recess 130. Alternatively, other types of retention mechanisms known in the art may be used.

In one embodiment, a locking mechanism 134 may be interconnected to one of the cover plates. In FIGS. 1-2, 5-6, and 10, the locking mechanism 134 is interconnected to the first cover plate 18 with a plurality of fasteners 138 that may engage a plurality of holes formed in a cap plate 142 or a plurality of bosses formed in the cover plate. The locking mechanism 134 includes a cap plate 142, a slidable rod 146 having a first end 146A and a second end 146B, a finger grip 150 interconnected to the second end 146B of the slidable rod 146, and a spring 154 operably associated with the finger grip 150. The spring 154 may be configured to bias the finger grip 150, and thus the slidable rod 146, towards an unlocked or locked position. In a locked position, the first end 146A of the slidable rod 146 slides into a groove 158 formed in each holder 98 of the first sharpening tool 10 and the second sharpening tool 14. In operation, when each holder 98 associated with the first sharpening tool 10 and the second sharpening tool 14 rotates into a sharpening position, each groove 158 formed in the side surface 126 of each holder 98 aligns with each other and with the path of the slidable rod 146, thereby allowing the first end 146A of the slidable rod 146 to be slidably positioned in grooves 158 to lock the first sharpening tool 10 and the second sharpening tool 14 in their respective sharpening positions. Alternatively, the locking mechanism 134 may be oriented perpendicular to the longitudinal axis of the cover plate 18 or 22, and may extend

13

through the rotating holders **98** of the sharpening rods or tabs **90** and **92** of the hand guards to lock the first and second sharpening tools and hand guards in the sharpening position.

Referring now to FIG. 3, a front elevation view of a blade-sharpening apparatus **2** is provided. In FIG. 3, the first sharpening tool **10** and the second sharpening tool **14** have been rotated to a sharpening position in which the first sharpening tool **10** and the second sharpening tool **14** are positioned at a predetermined angle α relative to each other. The predetermined angle α is bisected by a vertical plane **162** passing through the axis of rotation **26**. As previously discussed, the predetermined angle may be based on the particular tool to be sharpened and may be adjustable. Also illustrated in FIG. 3, hand guards **78**, **82** have been rotated to a guard position in which the hand guards **78**, **82** are positioned between the first sharpening tool **10** and the first cover plate **18**. In this configuration, a user can safely place their hand on the first cover plate **18** to hold the blade-sharpening apparatus **2** stationary.

Also shown in FIG. 3, the first cover plate **18** and the second cover plate **22** have been rotated to an unfolded position in which the first cover plate **18** and the second cover plate **22** extend away from each other and act as a base of the blade-sharpening apparatus **2**. In FIG. 3, the first cover plate **18** and the second cover plate **22** are positioned substantially co-planar with a horizontal plane **166**. As such, in this embodiment, the first cover plate **18** and the second cover plate **22** are rotatable between about 180 degrees. The range of motion of the first cover plate **18** and the second cover plate **22** can be altered depending on the application. For example, in one alternative embodiment, the first cover plate **18** and the second cover plate **22** are rotatable between about 270 degrees.

Referring now to FIG. 4, a right-side elevation view of a blade-sharpening apparatus **2** is provided. The first hand guard **78** and the second hand guard **82** have been rotated to a guard position in which the hand guards **78**, **82** are angled outwardly from the first sharpening tool **10** and the second sharpening tool **14**. Specifically, when the hand guards **78**, **82** are rotated to the guard position, a second end **78B** of the first hand guard **78** is rotated to a position outside of a perimeter edge **19** of the first cover plate **18** and/or a perimeter edge **23** of the second cover plate **22** and a second end **82B** of the second hand guard **82** is rotated to a position outside of the perimeter edge **19** of the first cover plate **18** and/or the perimeter edge **23** of the second cover plate **22**. Thus, the hand guards **78**, **82** extend outwardly from the perimeter edges **19**, **23** of the first and second cover plates **18**, **22**. The outward orientation helps protect a user's hand, wrist, and/or arm when placed on the first cover plate **18**. As illustrated in FIG. 5, the first end **78A** of the first hand guard **78** is positioned between the first knuckle **46A** and the second knuckle **46B** of the second cover plate **22**, and the first end **82A** of the second hand guard **82** is positioned between the third knuckle **46C** and the fourth knuckle **46D** of the second cover plate **22**. The sides of the knuckles **46A**, **46B**, **46C**, **46D** guide the hand guards **78**, **82** during rotation between a storage position and a guard position. When in the storage position, the hand guards **78**, **82** are positioned within an interior space defined by the first cover plate **18** and the second cover plate **22**. When in the guard position, the hand guards **78**, **82** extend beyond the outermost exterior surfaces of the first cover plate **18** and the second cover plate **22** to provide additional protection for a user's hand during sharpening. The outward orientation of the hand guards **78**, **82** relative to the cover plates **18**, **22** and/or the sharpening tools **10**, **14** may be altered in various embodiments.

14

Referring to FIG. 6, a cross-section view taken along line **6-6** of the blade-sharpening apparatus **2** shown in FIG. 5 is illustrated. A locking mechanism **134** is interconnected to the first cover plate **22** with a plurality of fasteners **138**. A slidable rod **146** is disposed beneath a cap plate **142** and is positioned in grooves **158** formed in the side surface **126** of a holder **98** to lock the holder **98** in a sharpening position. A spring **154** biases the slidable rod **146** towards the unlocked position, in which the blade-sharpening apparatus **2** can rotate into a folded or an unfolded position. A finger grip **150** is operably associated with the spring **154** and the slidable rod **146** to allow a user to position the slidable rod **146** within the grooves **158**, thereby locking the holder **98** in its sharpening position. Once the slidable rod **146** operably engages the holders **98**, the slidable rod **146** may be locked into place. Alternatively, a locking mechanism may be positioned in perpendicular orientation to the longitudinal axis of the cover and can be selectively positioned to lock the cover plates, hand guards **78**, **82**, and sharpening tools **10**, **14** in a sharpening position.

Referring to FIGS. 7-9, a blade-sharpening apparatus **2** is shown in a folded, or closed, position. In particular, the first cover plate **18** and/or the second cover plate **22** have been rotated into a folded position in which the first cover plate **18** and the second cover plate substantially enclose the first sharpening tool **10**, the second sharpening tool **14**, the first hand guard **78**, and the second hand guard **82**. In the folded position, the blade-sharpening apparatus **2** can be easily transported for in-the-field sharpening tasks.

Referring to FIG. 10, a cross-section view taken along line **10-10** of the blade-sharpening apparatus **2** shown in FIG. 7 is provided. In FIG. 10, the blade-sharpening apparatus **2** is in a folded position. The first sharpening tool **10**, the second sharpening tool **14**, the first hand guard **78**, and the second hand guard **82** are held in their respective storage positions by receptacles **62** formed in the first cover plate **18** and the second cover plate **22**. A cap plate **142** is interconnected to the first cover plate **18** with fasteners **138**, and a finger grip **150** is slidably interconnected to the cap plate **142**. The second cover plate **22** includes protruding latch members **66** which are positioned in corresponding latch receptacles **70** formed in the first cover plate **18** to secure the blade-sharpening apparatus **2** in the folded position.

While various embodiments have been described in detail, it is apparent that modifications and alterations of those embodiments will occur to those skilled in the art. For example, although one example of a hinge mechanism, particularly a pin extending through an aperture formed in a first end of various components, has been illustrated and described, other types of hinge mechanisms may be utilized. As an example, protrusions may be formed on one component and configured to interact with an opening in another component. As another example, a bearing, bushing, and/or ball detent may be utilized. As a further example, multiple axes hinge mechanisms may be utilized to interconnect various components, such as cover plates and/or sharpening tools. Other mechanisms known in the art also may be utilized to interconnect various components while permitting rotation of the components.

Various features have been grouped together in one or more aspects, embodiments, or configurations for the purpose of streamlining the disclosure. However, it should be understood that various features of the certain aspects, embodiments, or configurations of the disclosure may be combined in alternate aspects, embodiments, or configurations. It is to be expressly

15

understood that such modifications and alterations are within the scope and spirit of the claimed invention, as set forth in the following claims.

What is claimed is:

1. A blade-sharpening apparatus, comprising:
a foldable case positionable between a folded position and an unfolded position;

a first sharpening tool having a first end and a second end, the first end of the first sharpening tool interconnected to the foldable case, the first sharpening tool rotatable between a storage position and a sharpening position, wherein rotation of the first sharpening tool is coupled to the foldable case; and

a holder having a first end rotatably interconnected to the foldable case and a second end, wherein the first sharpening tool comprises a sharpening rod removably interconnected to the holder, wherein the sharpening rod has a triangular cross-section, and wherein the second end of the holder includes a predetermined geometry adapted to receive and selectively orient the sharpening rod.

2. The blade-sharpening apparatus of claim **1**, further comprising a second sharpening tool having a first end and a second end, the first end of the second sharpening tool interconnected to the foldable case, the second sharpening tool rotatable between a storage position and a sharpening position, and wherein a rotation of the second sharpening tool is coupled to the foldable case.

3. The blade-sharpening apparatus of claim **2**, wherein the foldable case comprises a first cover plate rotatably interconnected to a second cover plate.

4. The blade-sharpening apparatus of claim **3**, further comprising a pin extending through an aperture in a first end of the first cover plate, a first end of the second cover plate, the first end of the first sharpening tool, and the first end of the second sharpening tool to interconnect the first sharpening tool and the second sharpening tool to the foldable case.

5. The blade-sharpening apparatus of claim **3**, wherein when the foldable case is in the folded position, the first and second cover plates substantially enclose the first and second sharpening tools.

6. The blade-sharpening apparatus of claim **1**, wherein the first sharpening tool is adapted to be selectively locked in the sharpening position to retain a substantially fixed position.

7. The blade-sharpening apparatus of claim **3**, further comprising at least one hand guard with a first end which rotates about a common axis shared with the first sharpening tool, and having a second end which rotates to a position outside of at least one of a perimeter edge of the first cover plate and a perimeter edge the second cover plate.

8. A blade-sharpening apparatus, comprising:
a first cover plate having a first end and a second end;

a second cover plate having a first end and a second end, the first end of the second cover plate interconnected to at least one of the first end of the first cover plate and a hinge mechanism, wherein at least one of the first and second cover plates is rotatable between a folded position and an unfolded position;

a first holder having a first end and a second end, the first end of the first holder interconnected to at least one of the first cover plate, the second cover plate, and the hinge mechanism, wherein the first holder is rotatable between a storage position and a sharpening position;

a first sharpening rod removably interconnected to the second end of the first holder;

a second holder having a first end and a second end, the first end of the second holder interconnected to at least one of the first cover plate, the second cover plate, and the hinge

16

mechanism, wherein the second holder is rotatable between a storage position and a sharpening position; and

a second sharpening rod removably interconnected to the second end of the second holder.

9. The blade-sharpening apparatus of claim **8**, wherein when the first and second cover plates are in the unfolded positions, the first and second cover plates extend away from each other and act as a base of the blade-sharpening apparatus.

10. The blade-sharpening apparatus of claim **8**, wherein when the first and second cover plates are in the folded positions, the first and second cover plates substantially enclose the first holder, the first sharpening rod, the second holder, and the second sharpening rod.

11. The blade-sharpening apparatus of claim **8**, wherein rotation of the first and second holders is coupled to at least one of the first and second cover plates, and wherein rotation of the at least one of the first and second cover plates from the folded position to the unfolded position rotates the first and second holders from their respective storage positions to their respective sharpening positions.

12. The blade-sharpening apparatus of claim **11**, wherein the first end of each holder includes a tab configured to interact with the first end of at least one of the first and second cover plates to couple the first and second holders to the at least one of the first and second cover plates.

13. The blade-sharpening apparatus of claim **8**, wherein the first and second holders are adapted to be selectively locked in their respective sharpening positions to retain a substantially fixed position.

14. The blade-sharpening apparatus of claim **8**, further comprising at least one hand guard having an end interconnected to at least one of the first and second cover plates, wherein the at least one hand guard is rotatable.

15. The blade-sharpening apparatus of claim **14**, wherein rotation of the at least one hand guard is coupled to the at least one of the first and second cover plates, wherein rotation of the at least one of the first and second cover plates from the folded position to the unfolded position rotates the at least one hand guard from a storage position to a guard position.

16. The blade-sharpening apparatus of claim **8**, wherein the first and second sharpening tools are oriented at a predetermined angle relative to each other when the first and second sharpening tools are in their respective sharpening positions.

17. The blade-sharpening apparatus of claim **8**, further comprising a pin extending through an aperture in the first end of the first cover plate, the first end of the second cover plate, the first end of the first holder, and the first end of the second holder to interconnect the first and second holders to the first and second cover plates.

18. A method of assembling a foldable blade-sharpening apparatus, comprising:

providing a foldable case configured to rotate between a folded position and an unfolded position, a first sharpening tool having a first end and a second end, and a second sharpening tool having a first end and a second end;

interconnecting the first end of the first sharpening tool to the foldable case, wherein the first sharpening tool is rotatable between a first position of storage and a second position of sharpening;

interconnecting the first end of the second sharpening tool to the foldable case, wherein the second sharpening tool is rotatable between a first position of storage and a second position of sharpening; and

coupling the first and second sharpening tools to the foldable case, wherein when the first and second sharpening tools are in their respective first positions of storage the first and second sharpening tools are oriented in a substantially common plane, wherein when the first and second sharpening tools are in their respective second positions of sharpening the first and second sharpening tools are oriented in two distinct planes, and wherein each plane of the two distinct planes is at a predetermined angle.

19. The method of claim **18**, further comprising:

providing a first hand guard having a first end and a second end and a second hand guard having a first end and a second end;

interconnecting the first end of the first hand guard to the foldable case, wherein the first hand guard is rotatable between a first position of storage and a second position of use; and

interconnecting the first end of the second hand guard to the foldable case, wherein the second hand guard is rotatable between a first position of storage and a second position of use, and wherein the first and second hand guards are operably interconnected to the foldable case to rotate to a common plane when the foldable case is rotated from the unfolded position to the folded position and an outer-most end of the first hand guard and an outer-most end of the second hand guard are positioned outside of a peripheral edge of the foldable case.

* * * * *