



US008941597B2

(12) **United States Patent**  
**Chang et al.**

(10) **Patent No.:** **US 8,941,597 B2**  
(45) **Date of Patent:** **Jan. 27, 2015**

(54) **METHOD AND DEVICE FOR ANALYZING TWO-DIMENSION SENSING INFORMATION**

(75) Inventors: **Chin-Fu Chang**, Taipei (TW); **Cheng-Han Lee**, Taipei (TW); **Chi-Hao Tang**, Taipei (TW); **Shun-Lung Ho**, Taipei (TW)

(73) Assignee: **Egalax Empia Technology Inc.**, Taipei (TW)

(\*) Notice: Subject to any disclaimer, the term of this patent is extended or adjusted under 35 U.S.C. 154(b) by 333 days.

(21) Appl. No.: **12/923,807**

(22) Filed: **Oct. 8, 2010**

(65) **Prior Publication Data**

US 2011/0084928 A1 Apr. 14, 2011

**Related U.S. Application Data**

(60) Provisional application No. 61/298,252, filed on Jan. 26, 2010, provisional application No. 61/298,243, filed on Jan. 26, 2010, provisional application No. 61/250,051, filed on Oct. 9, 2009.

(51) **Int. Cl.**

**G06F 3/041** (2006.01)  
**G01R 27/26** (2006.01)  
**G06F 3/044** (2006.01)  
**G06F 3/047** (2006.01)

(52) **U.S. Cl.**

CPC ..... **G01R 27/2605** (2013.01); **G06F 3/0416** (2013.01); **G06F 3/044** (2013.01); **G06F 3/0418** (2013.01); **G06F 3/047** (2013.01); **G06F 2203/04103** (2013.01); **G06F 2203/04104** (2013.01); **G06F 2203/04111** (2013.01)

USPC ..... **345/173**; 345/174; 178/18.01; 178/18.06

(58) **Field of Classification Search**

CPC ..... G06F 3/041; G06F 3/044; G06F 3/0412; G06F 3/0488; G06F 2203/04104; G06F 3/03547; G06F 1/1626; G06F 3/038; G06F 17/30867; G06F 21/36; H03K 17/962; A63F 2300/1075

USPC ..... 345/156-184  
See application file for complete search history.

(56) **References Cited**

U.S. PATENT DOCUMENTS

4,639,720 A 1/1987 Rympalski et al.  
5,374,787 A 12/1994 Miller et al.  
5,412,200 A 5/1995 Rhoads  
5,543,588 A 8/1996 Bisset et al.  
5,644,512 A 7/1997 Chernoff et al.  
5,825,670 A 10/1998 Chernoff et al.  
5,861,583 A 1/1999 Schediwy et al.  
6,075,520 A \* 6/2000 Inoue et al. .... 345/173  
6,150,809 A 11/2000 Tiernan et al.  
6,723,929 B2 4/2004 Kent

(Continued)

FOREIGN PATENT DOCUMENTS

CN 1164286 A 11/1997  
CN 1596412 A 3/2005

(Continued)

*Primary Examiner* — Amare Mengistu

*Assistant Examiner* — Gloryvid Figueroa-Gibson

(74) *Attorney, Agent, or Firm* — WPAT, PC; Justin King

(57) **ABSTRACT**

A two-dimension (2-D) sensing information is analyzed for determining touch related sensing information. The touch related sensing information may include touch related sensing information with inner lower values within outer high values and with inner higher values within outer low values.

**21 Claims, 16 Drawing Sheets**

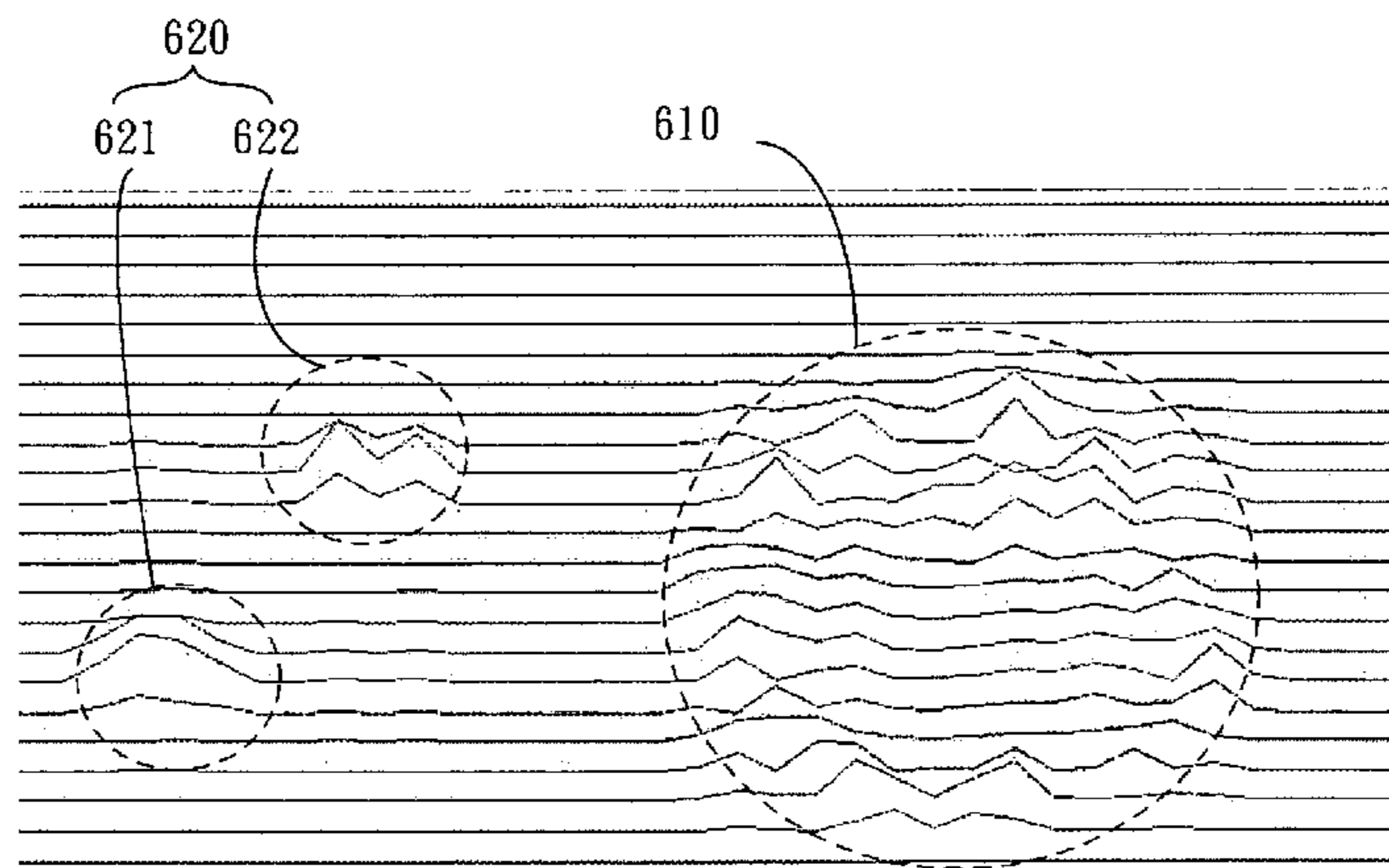

(56)

References Cited

U.S. PATENT DOCUMENTS

6,781,577	B2	8/2004	Shigetaka	
7,072,778	B2	7/2006	Swanson	
7,167,773	B2	1/2007	Schneider et al.	
7,315,793	B2	1/2008	Jean	
7,339,580	B2	3/2008	Westerman et al.	
7,663,607	B2	2/2010	Hotelling et al.	
7,728,816	B2	6/2010	Xu et al.	
8,089,470	B1	1/2012	Schediwy et al.	
8,102,376	B2	1/2012	Lii et al.	
8,169,421	B2	5/2012	Wright et al.	
8,212,782	B2	7/2012	Cho et al.	
2004/0108990	A1*	6/2004	Lieberman et al.	345/156
2005/0173820	A1	8/2005	Schneider et al.	
2006/0071674	A1	4/2006	Jean	
2006/0244735	A1	11/2006	Wilson	
2007/0109274	A1*	5/2007	Reynolds	345/173
2007/0229466	A1*	10/2007	Peng et al.	345/173
2007/0273574	A1	11/2007	Barnum	
2008/0048990	A1	2/2008	Cho et al.	
2008/0143681	A1	6/2008	Xiaoping	
2008/0147350	A1	6/2008	Jean	
2008/0158175	A1	7/2008	Hotelling et al.	
2008/0158185	A1	7/2008	Westerman	
2008/0180404	A1	7/2008	Han et al.	
2008/0196945	A1	8/2008	Konstas	
2008/0309629	A1*	12/2008	Westerman et al.	345/173
2008/0309634	A1	12/2008	Hotelling et al.	
2009/0066669	A1	3/2009	Olson	
2009/0085894	A1	4/2009	Gandhi et al.	
2009/0174675	A1	7/2009	Gillespie et al.	
2009/0211817	A1	8/2009	Chang et al.	
2009/0273571	A1	11/2009	Bowens	

2010/0079405	A1*	4/2010	Bernstein	345/174
2010/0156852	A1	6/2010	Chu et al.	
2010/0283785	A1	11/2010	Satulovsky	
2010/0295810	A1	11/2010	Nagata et al.	
2012/0043141	A1	2/2012	Xiaoping	
2012/0044150	A1	2/2012	Karpin et al.	

FOREIGN PATENT DOCUMENTS

CN	1720498	A	1/2006
CN	1811680	A	8/2006
CN	1845045	A	10/2006
CN	1885251	A	12/2006
CN	1942853	A	4/2007
CN	101059741	A	10/2007
CN	101105733	A	1/2008
CN	100419657	C	9/2008
CN	101261553	A	9/2008
CN	201156246	Y	11/2008
CN	201181467	Y	1/2009
CN	101369200	A	2/2009
CN	101452360	A	6/2009
CN	101470556	A	7/2009
CN	101526871	A	9/2009
CN	101539832	A	9/2009
CN	102023768	A	4/2011
EP	1191430	A1	3/2002
EP	1630652	A1	3/2006
GB	WO 2008083362	A1	7/2008
GB	WO 2009007704	A1	1/2009
JP	H0895701		4/1996
TW	408277		10/2000
TW	200401222	A	1/2004
TW	201112082		4/2011

\* cited by examiner

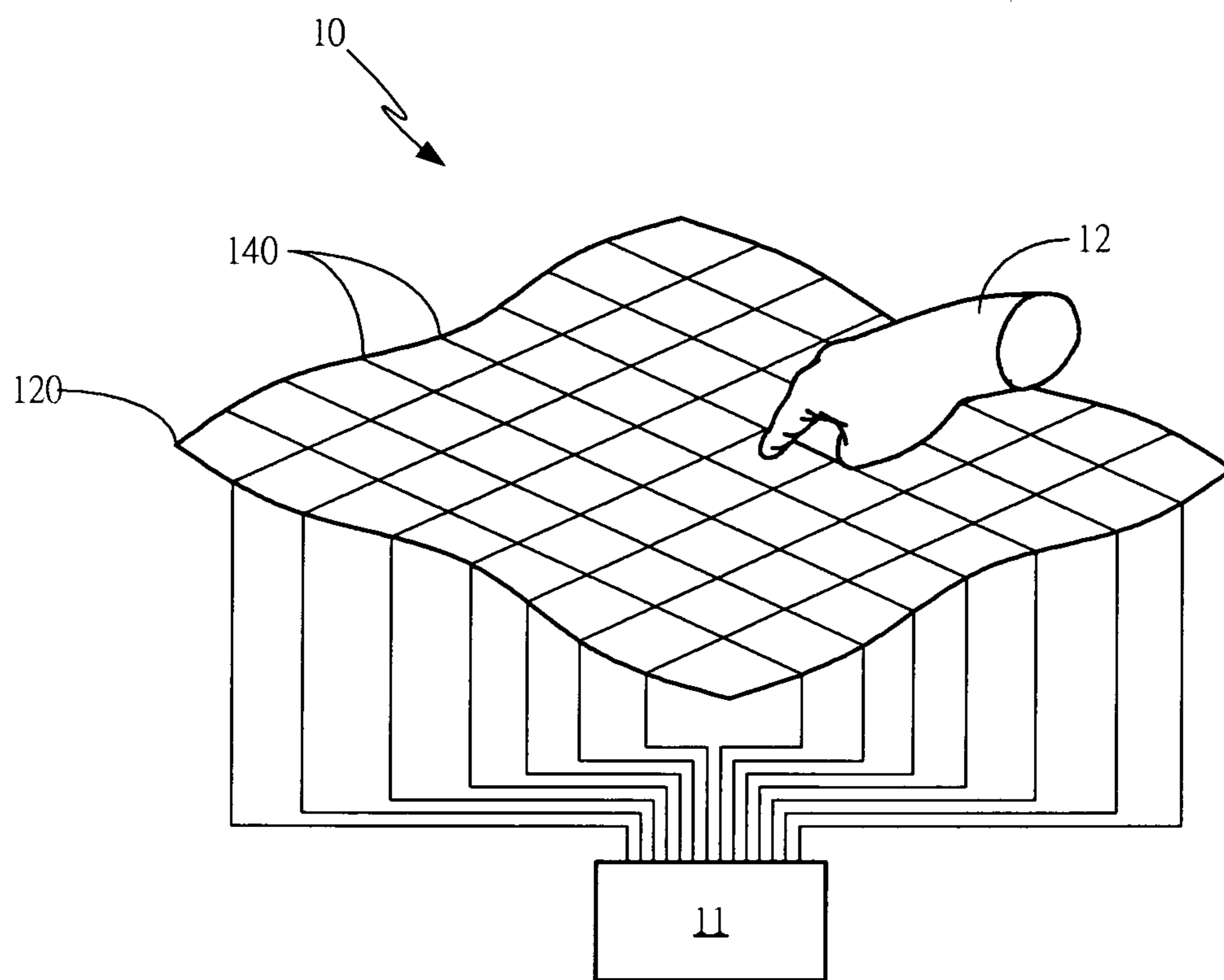

FIG. 1A (PRIOR ART)

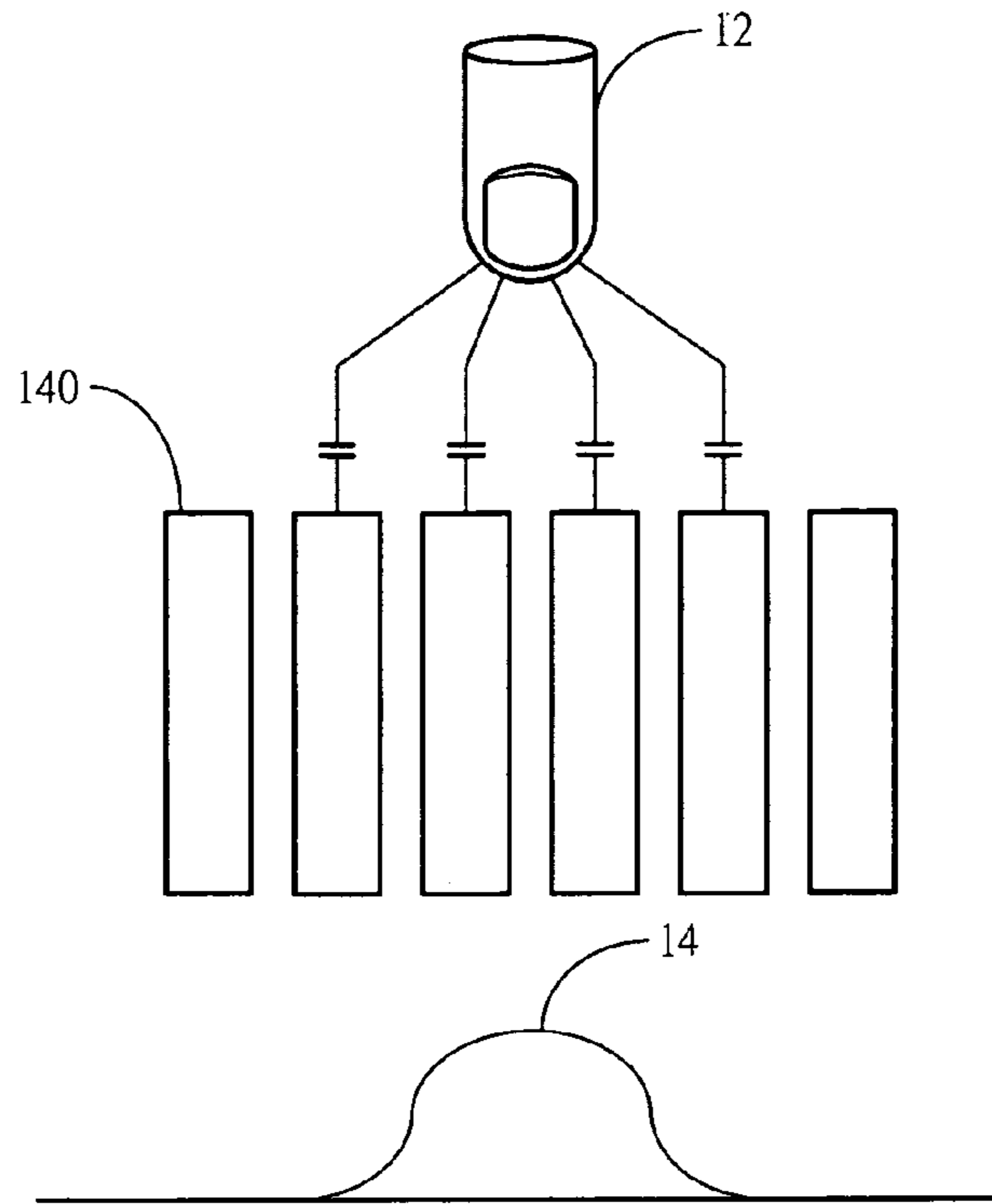

FIG. 1B (PRIOR ART)

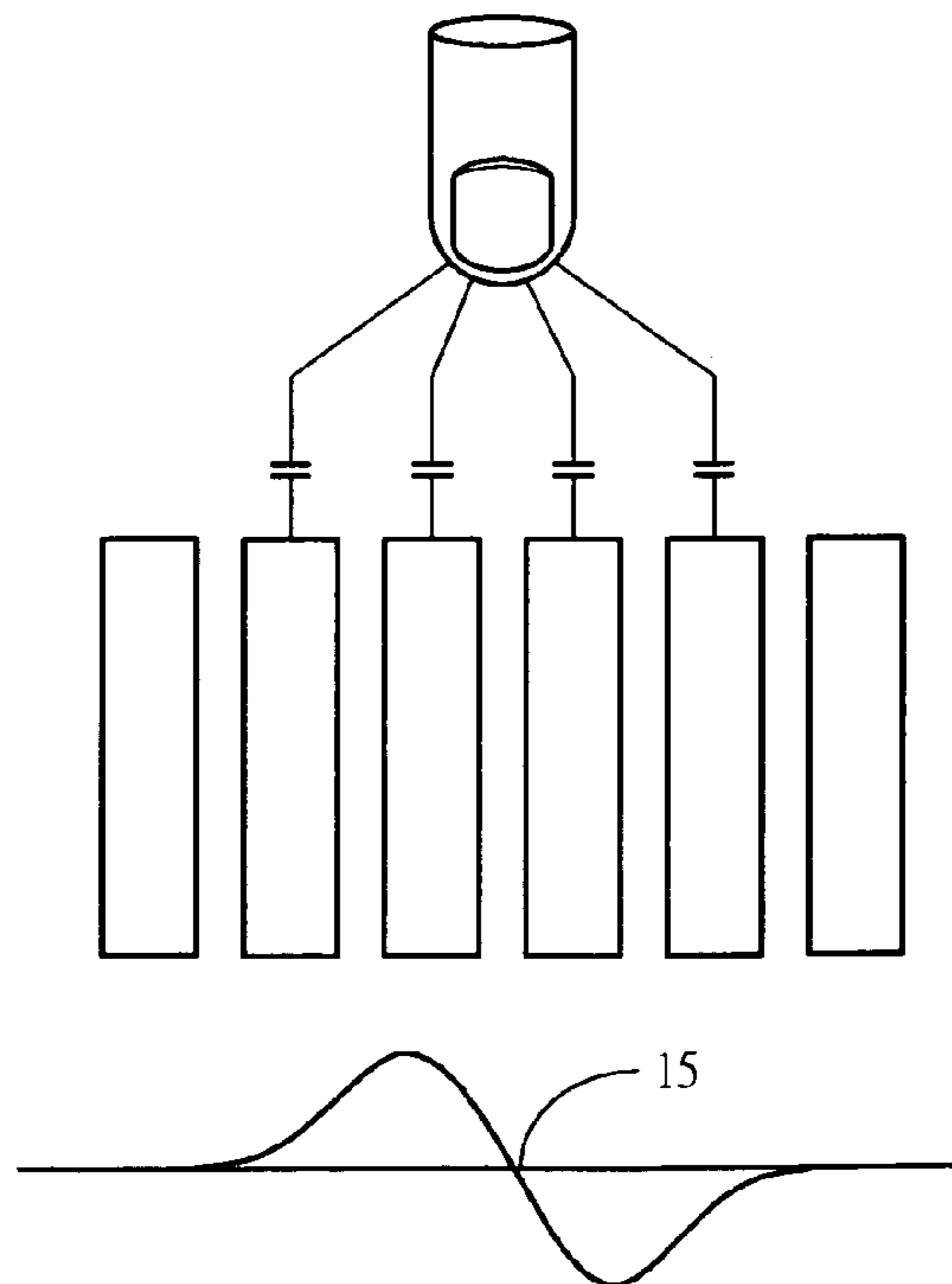

FIG. 1C

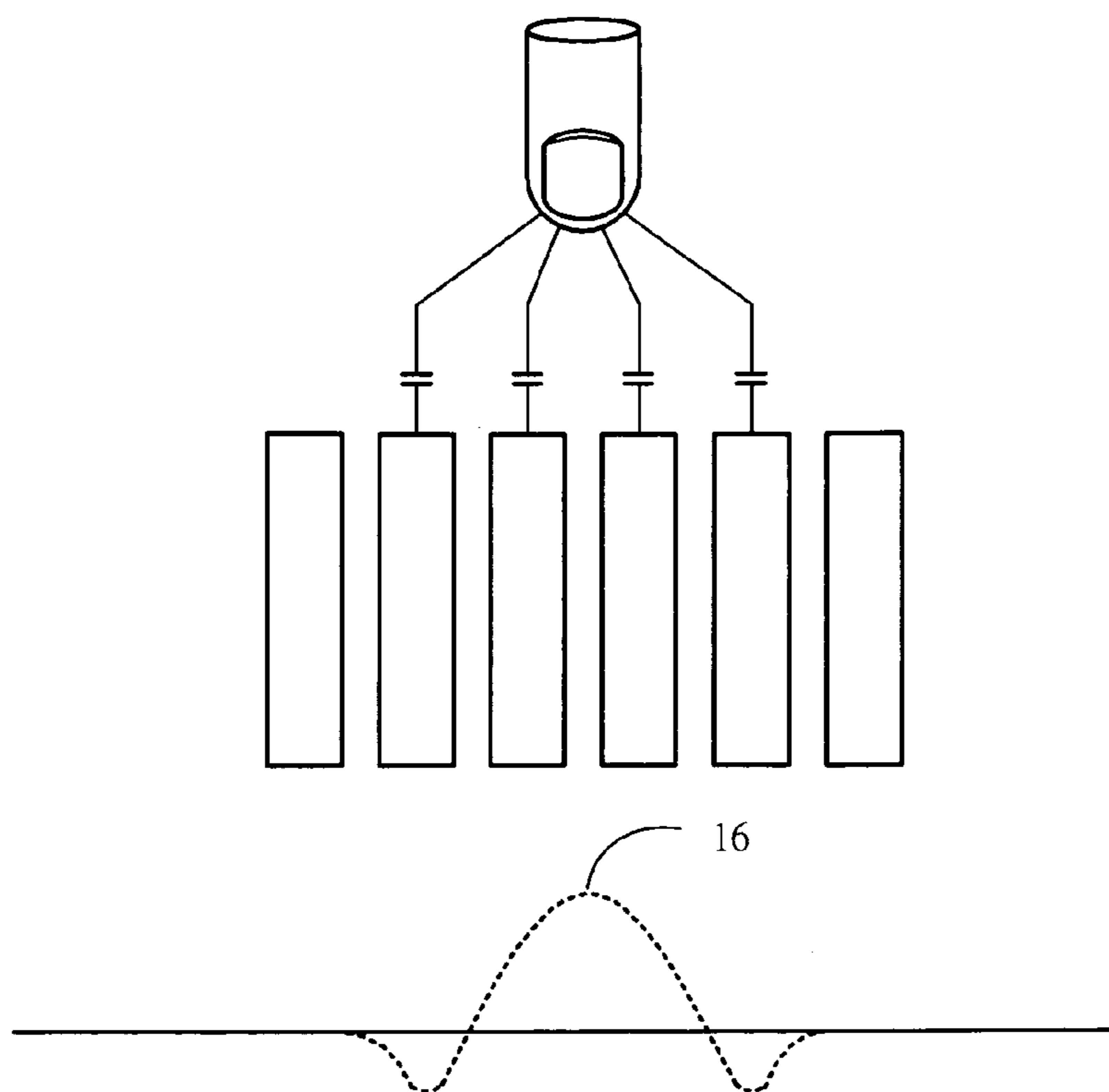

FIG. 1D

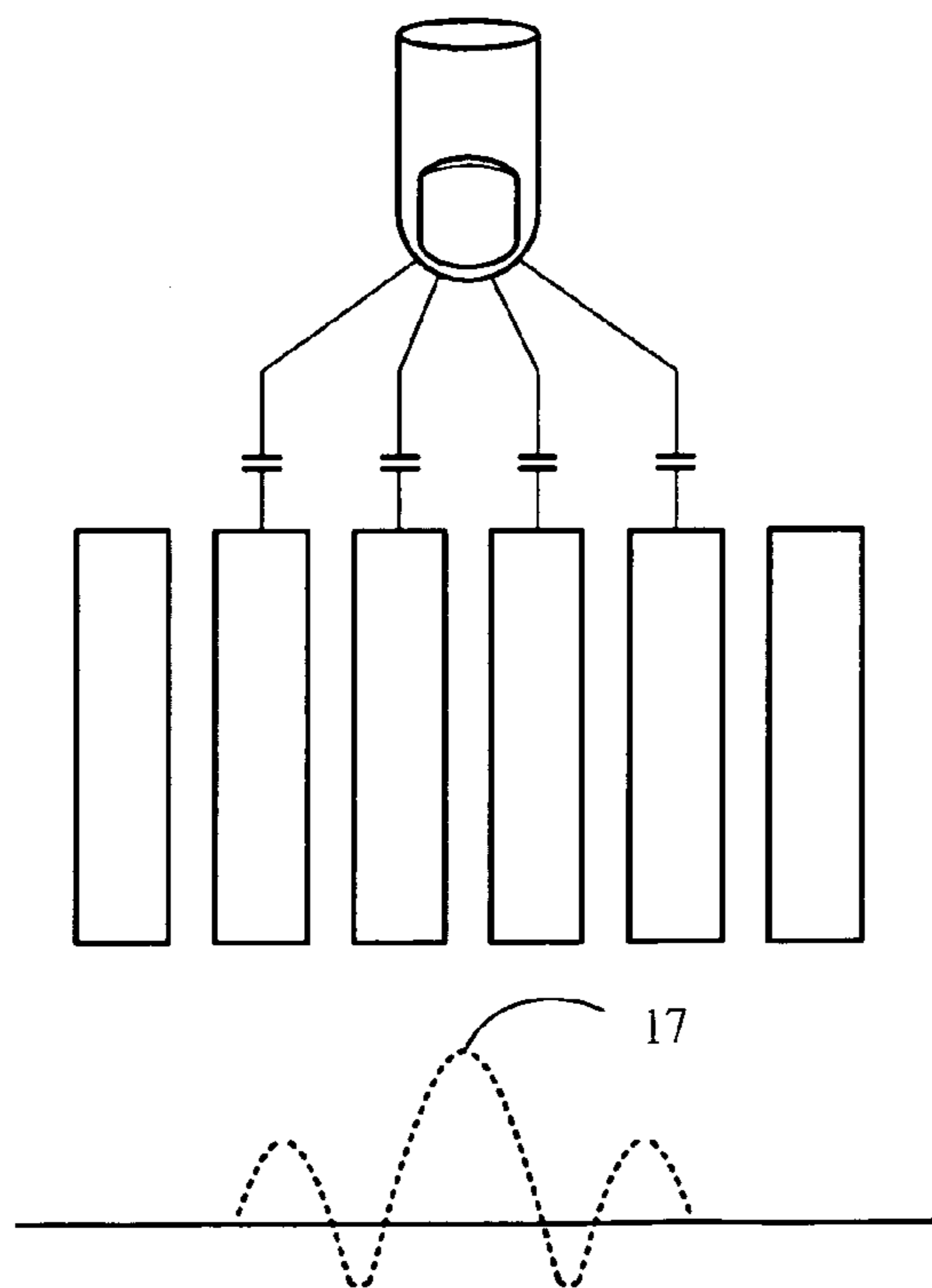

FIG. 1E

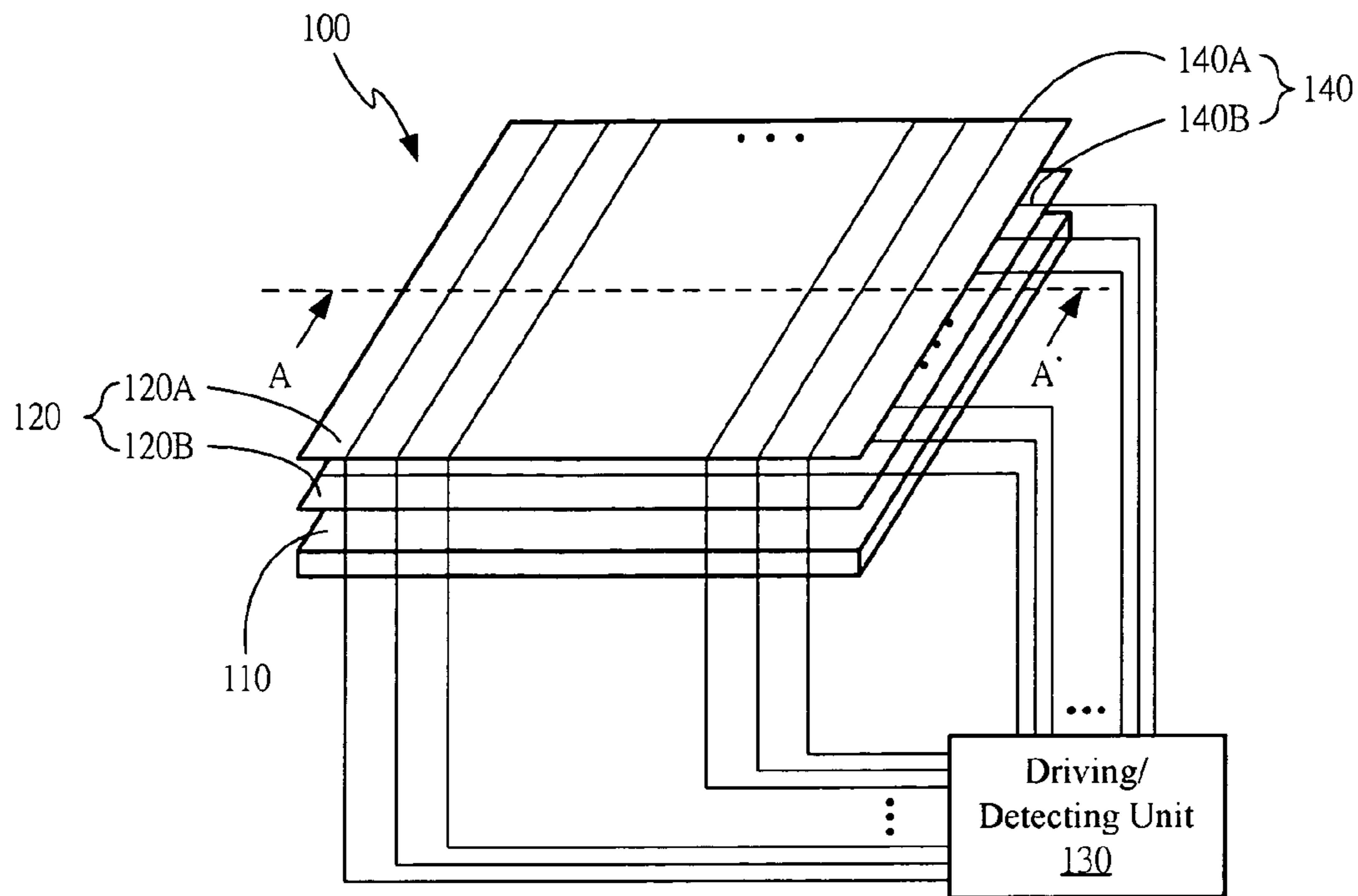

FIG. 1F

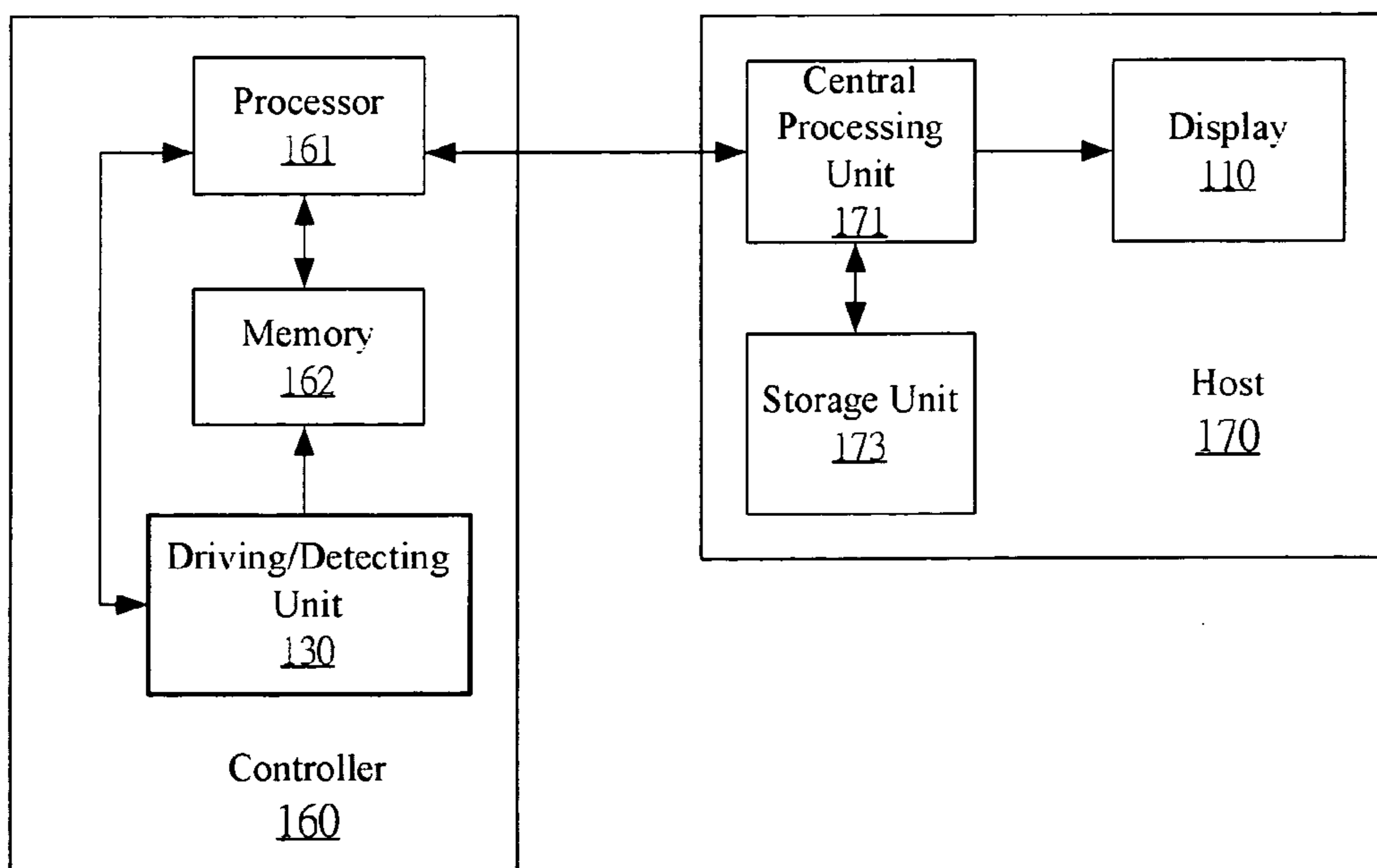

FIG. 1G

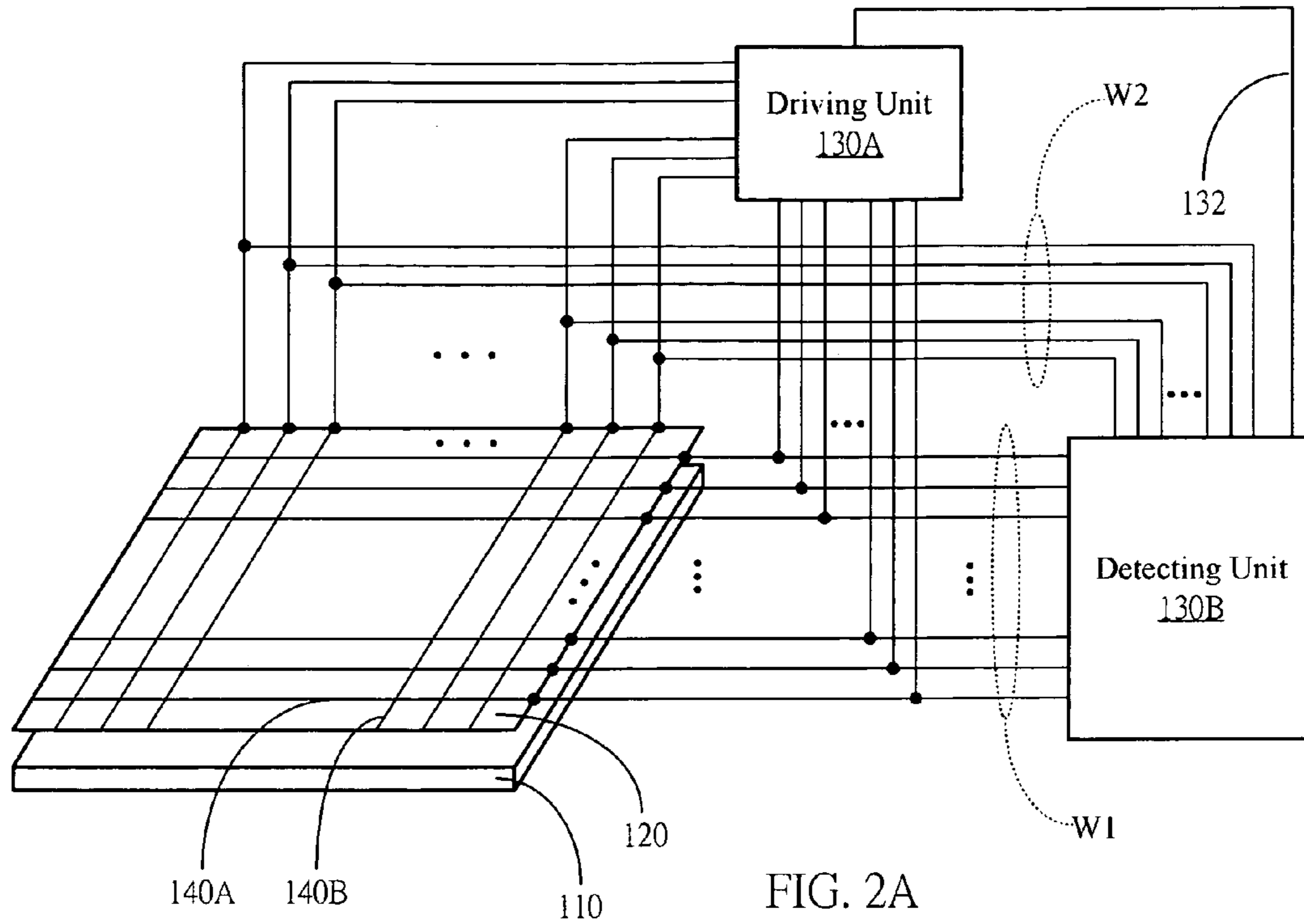

FIG. 2A

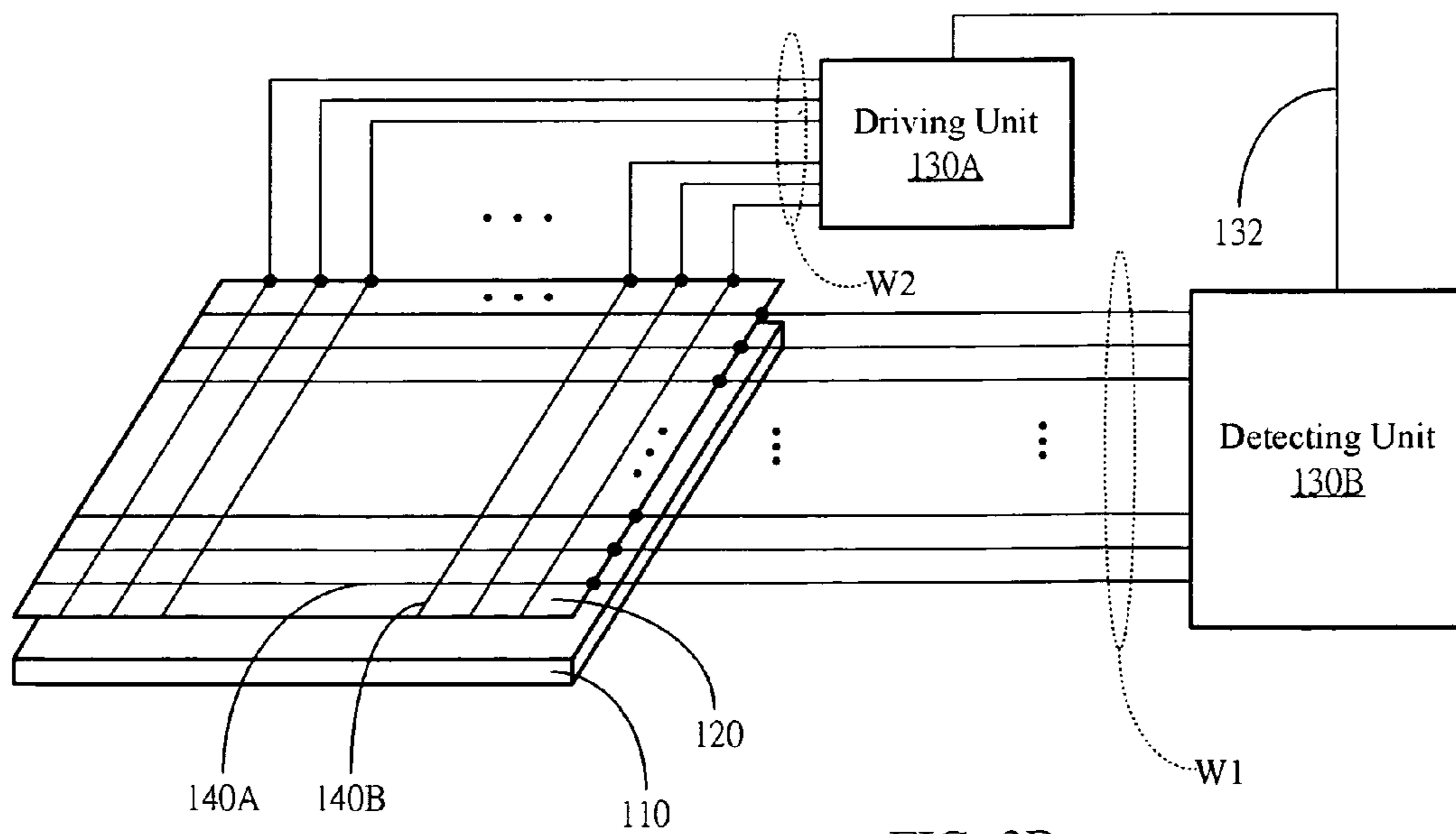

FIG. 2B

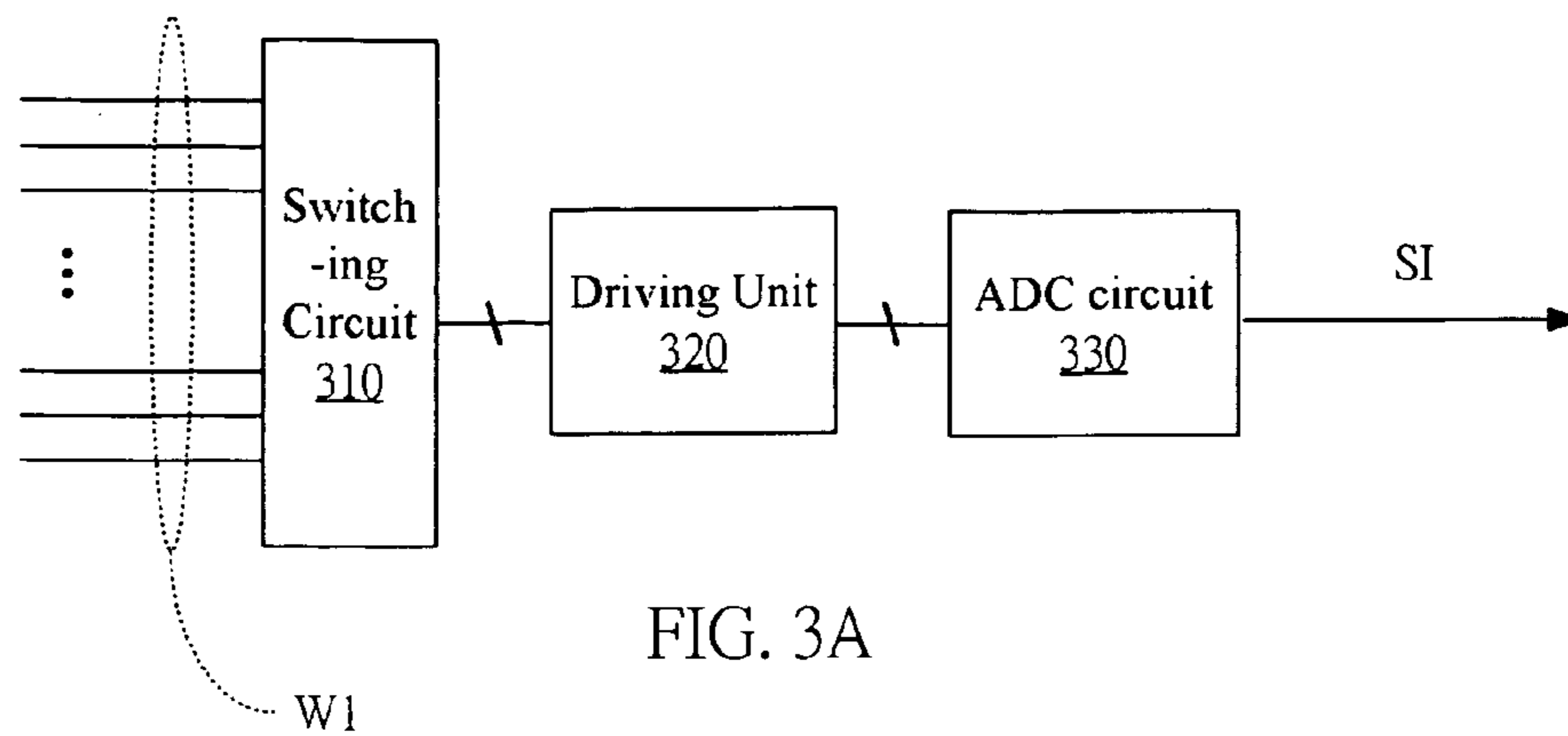

FIG. 3A

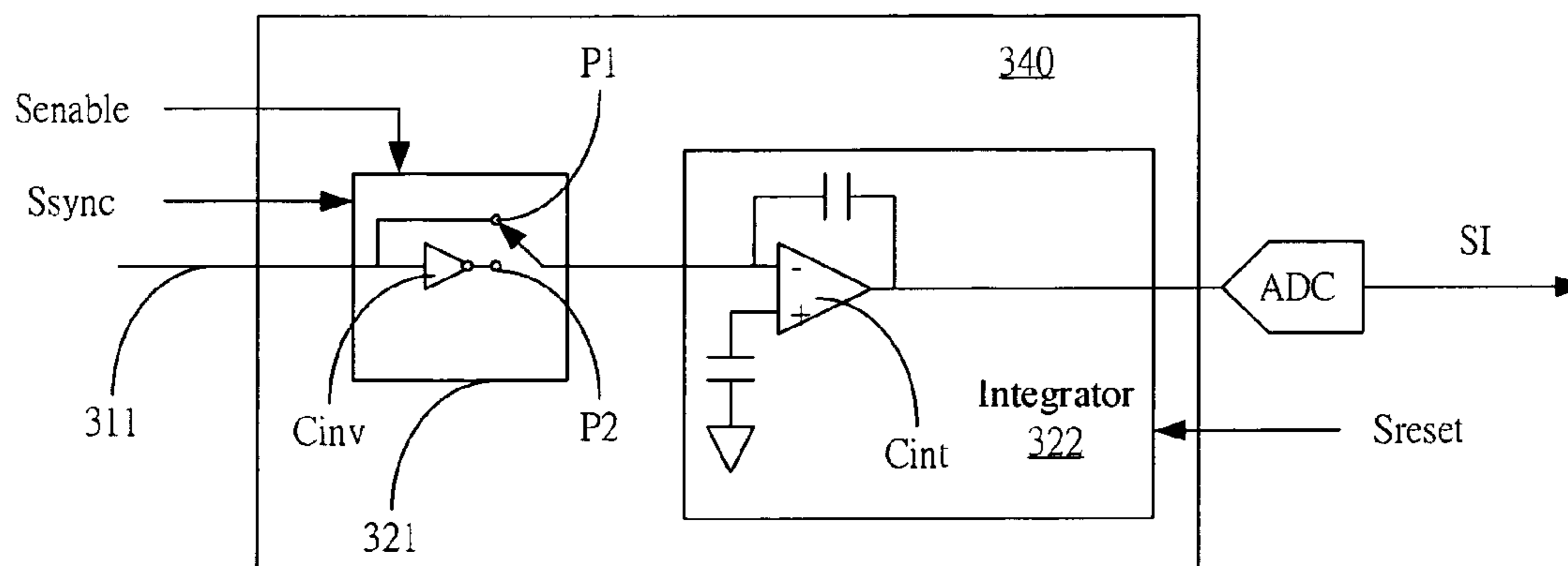

FIG. 3B

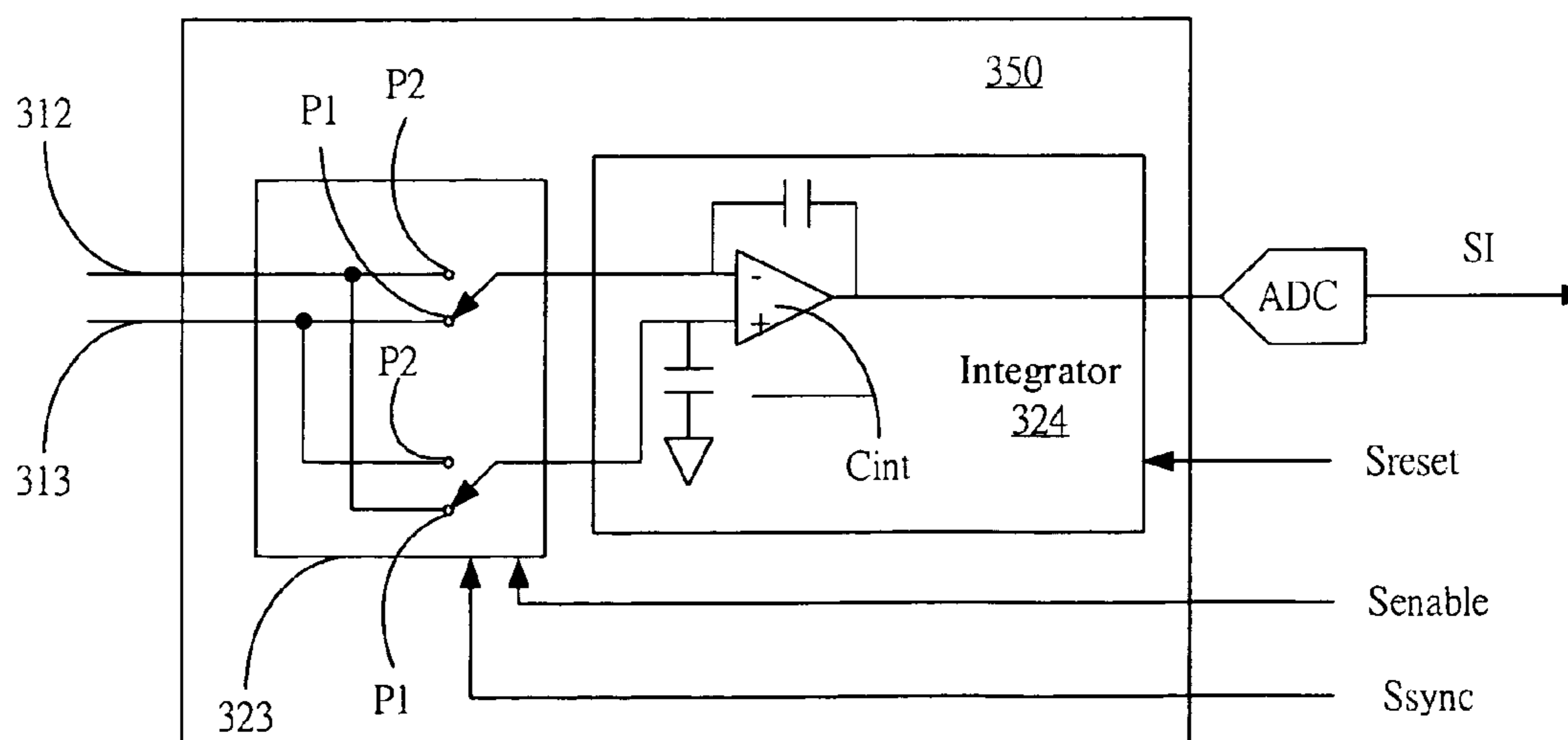

FIG. 3C



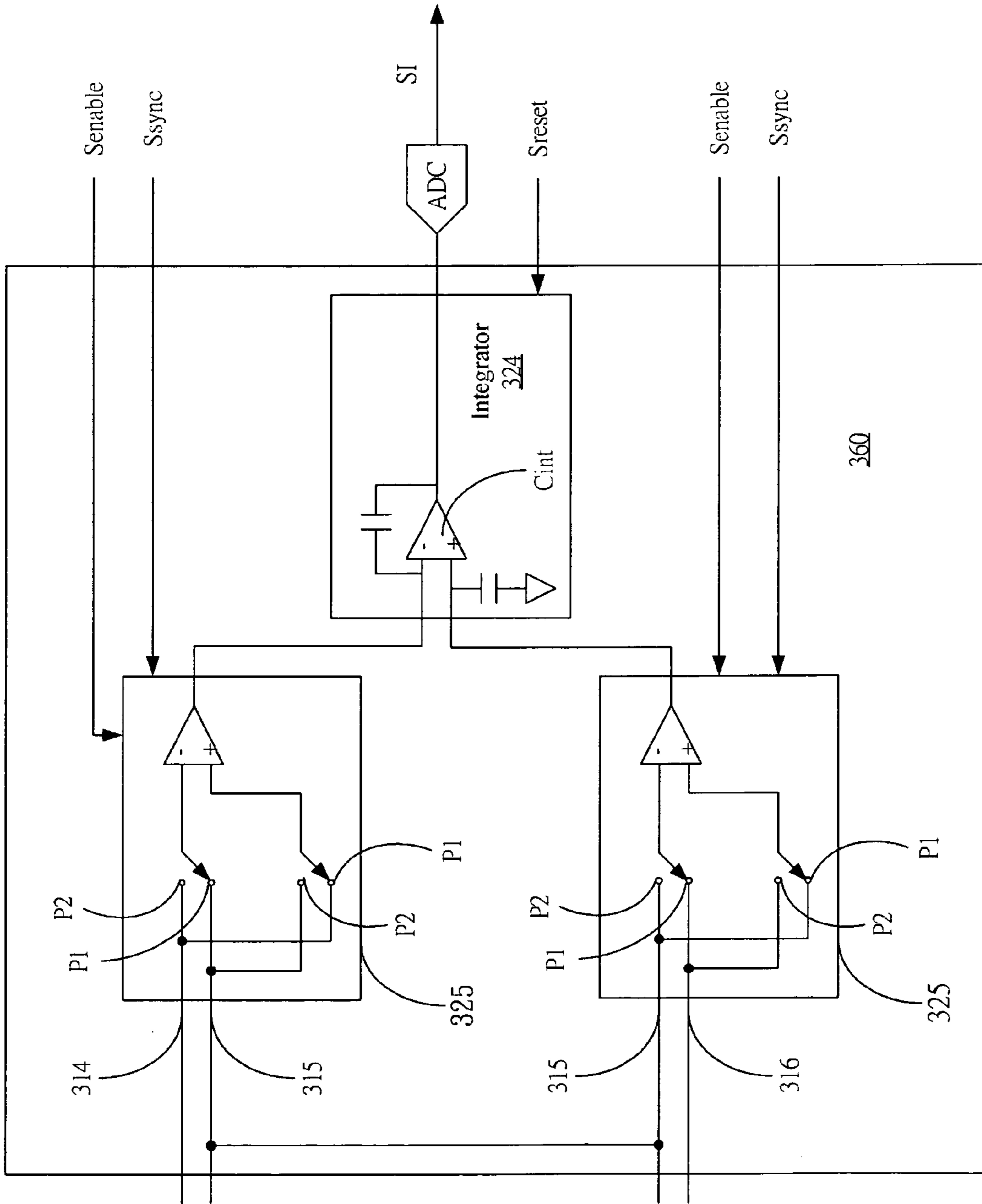

FIG. 3D

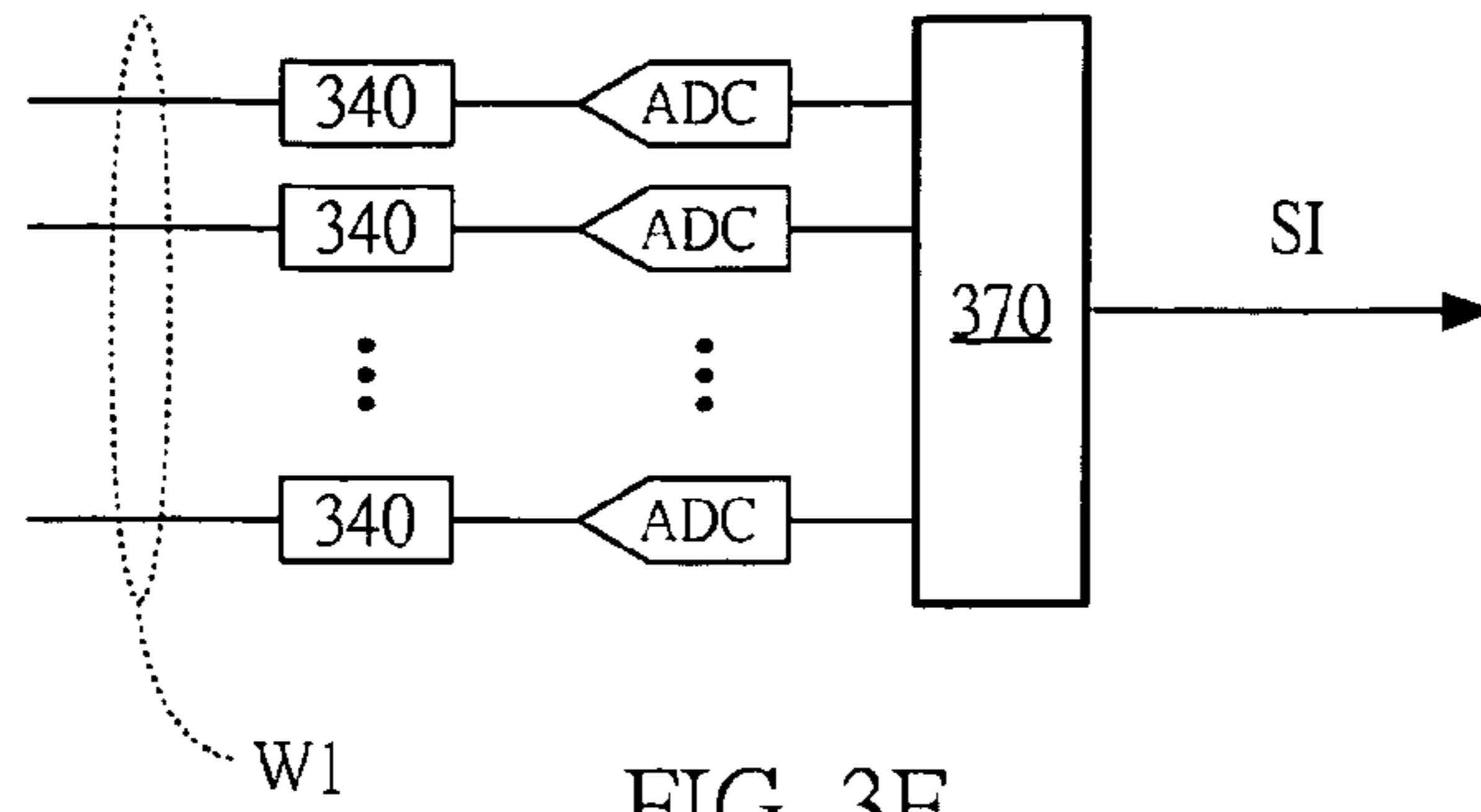

FIG. 3E

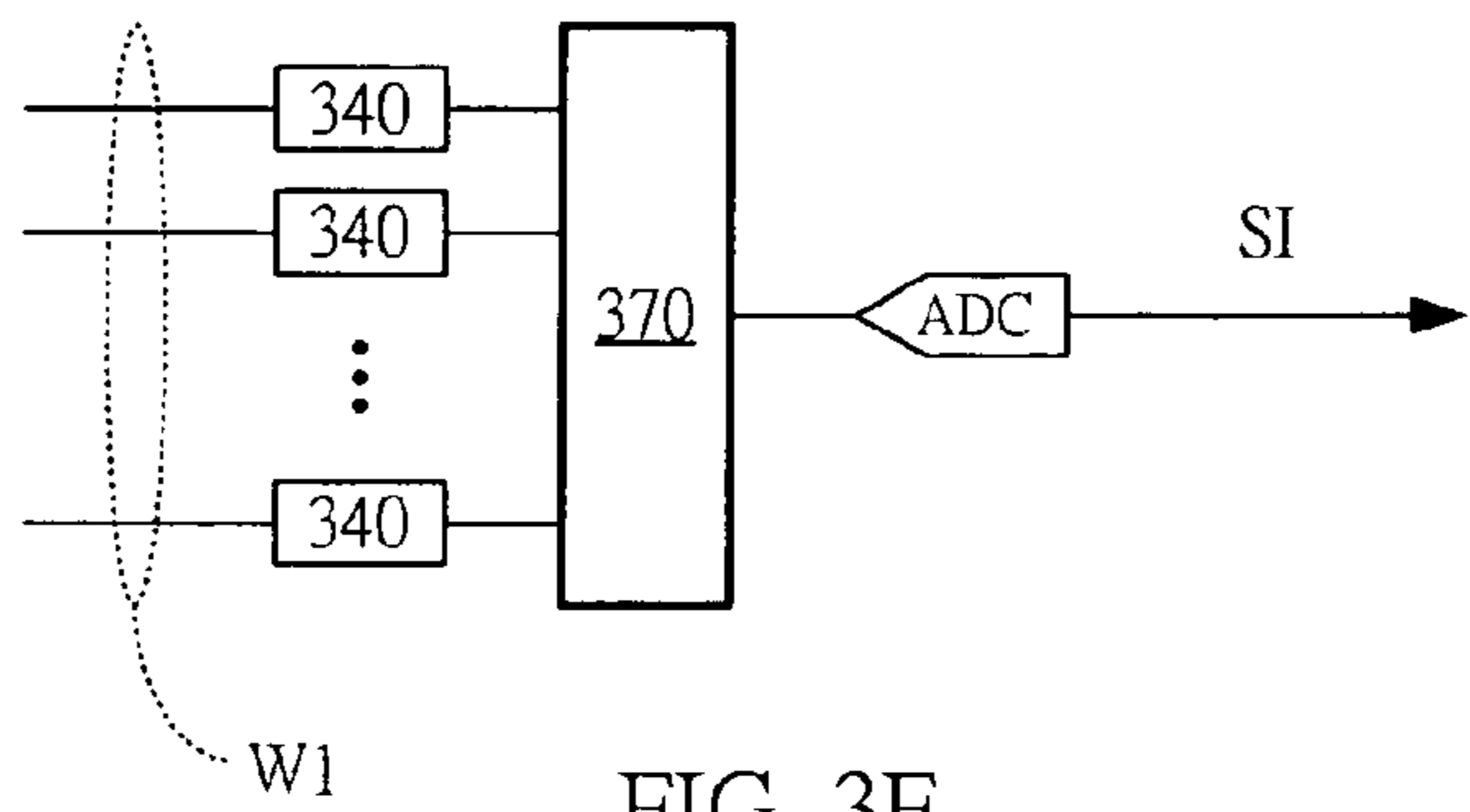

FIG. 3F

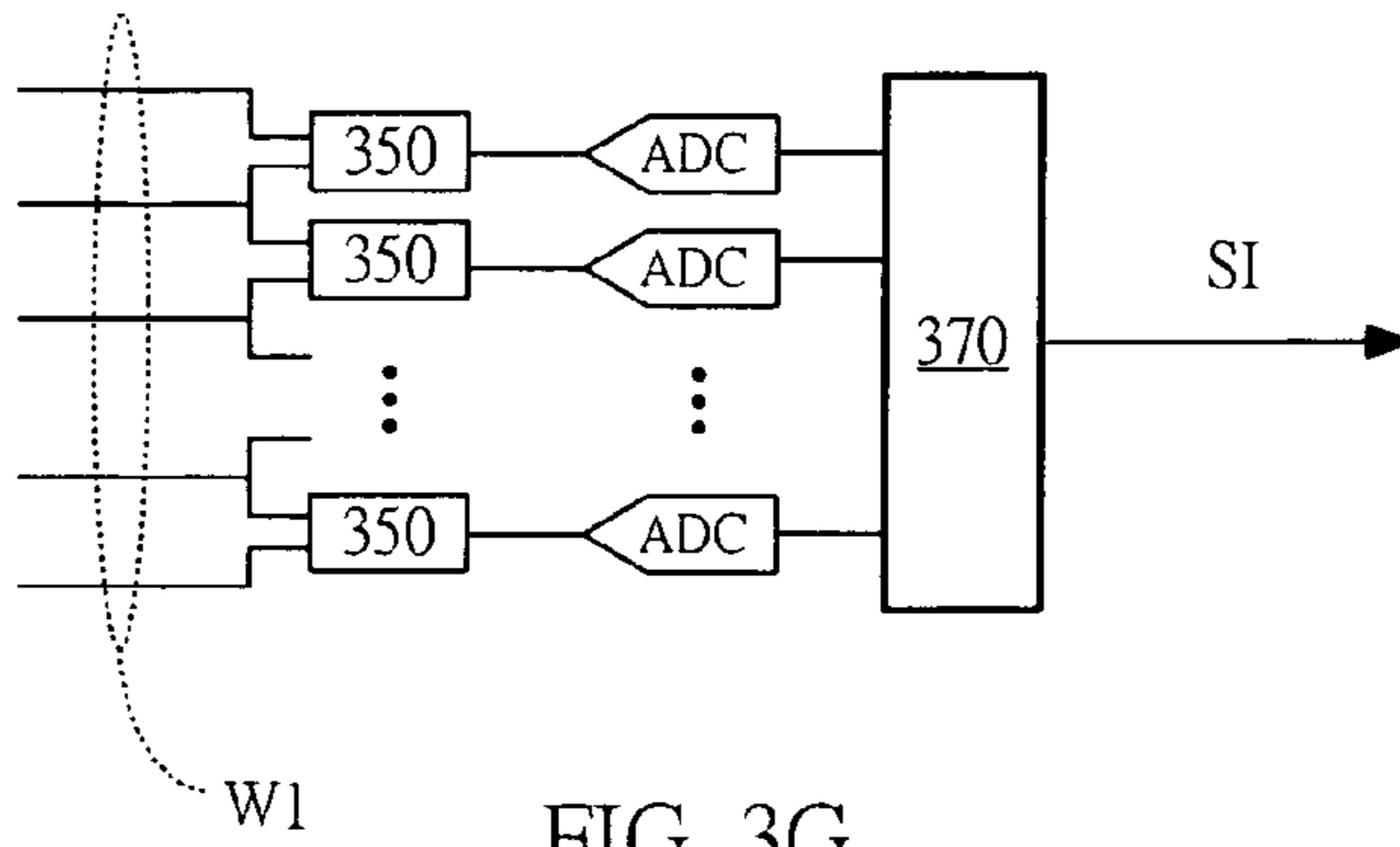

FIG. 3G

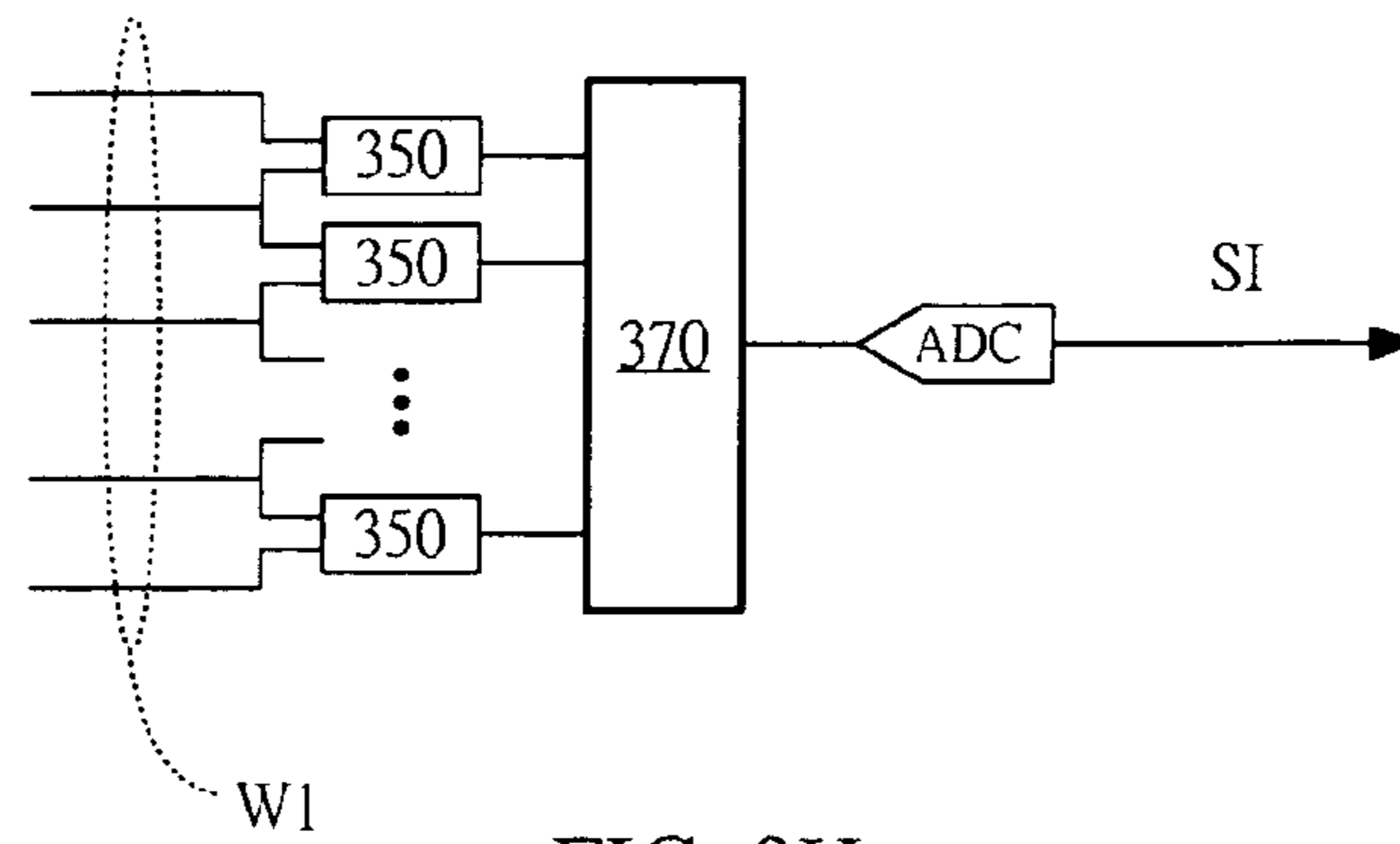

FIG. 3H

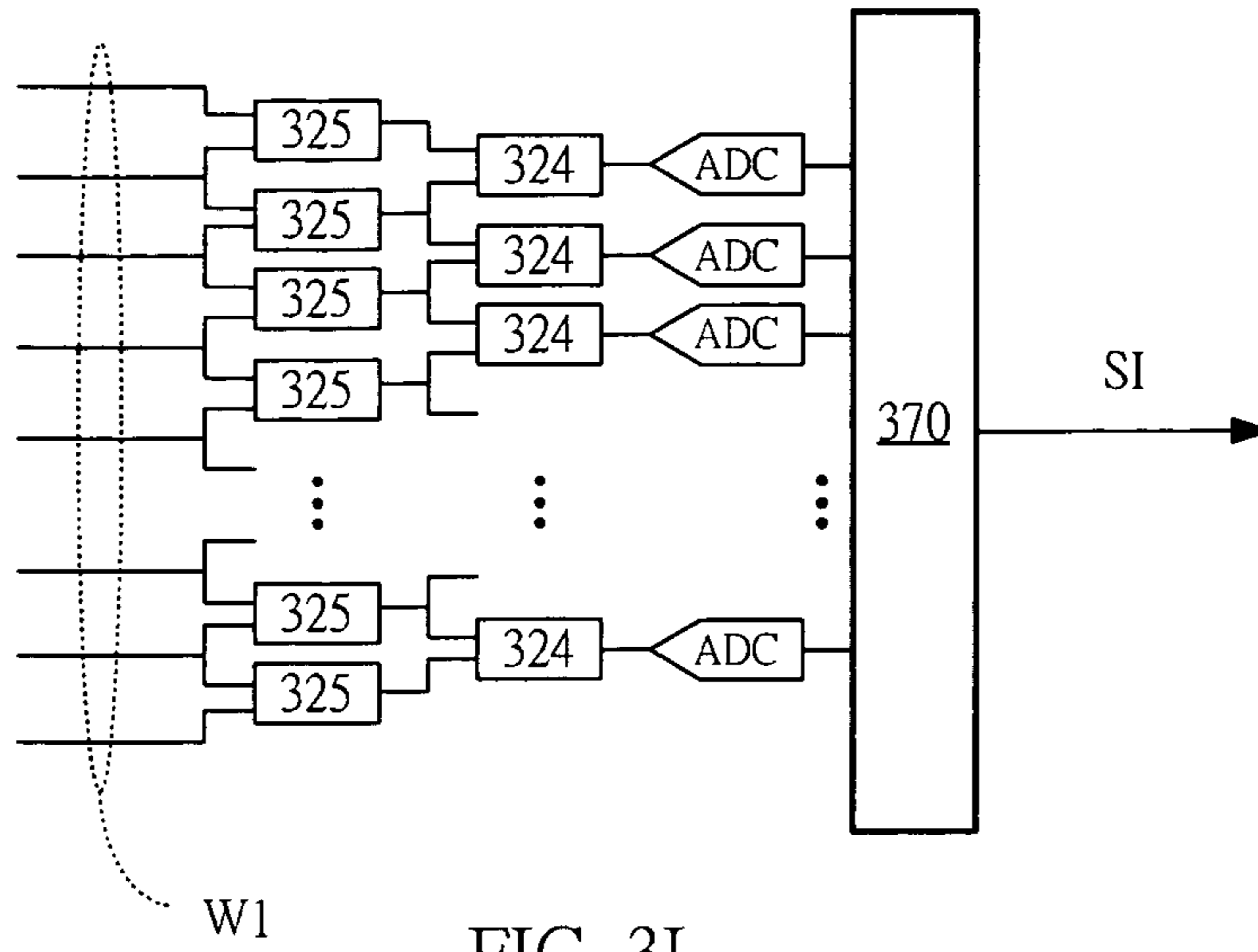

FIG. 3I

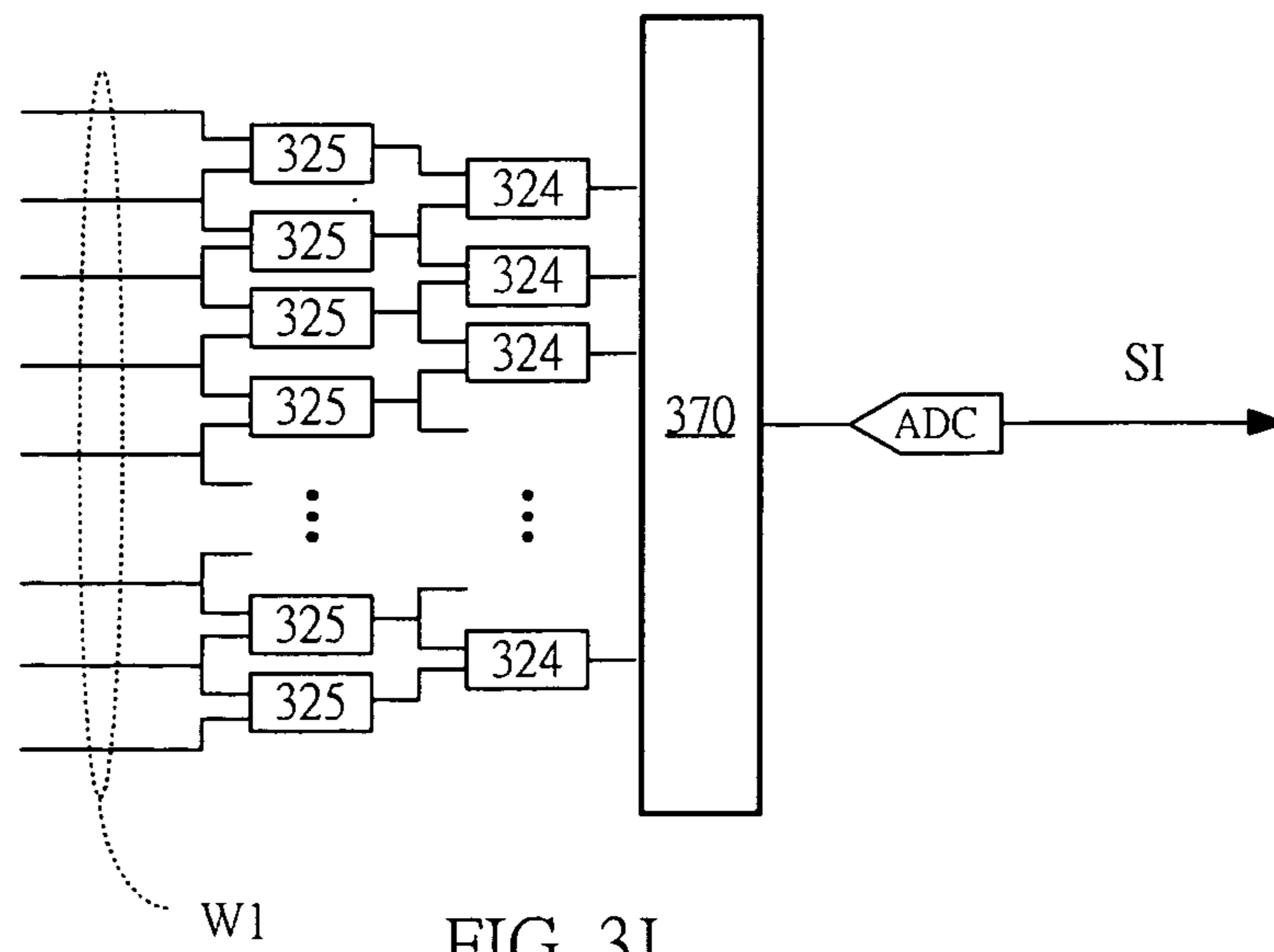

FIG. 3J

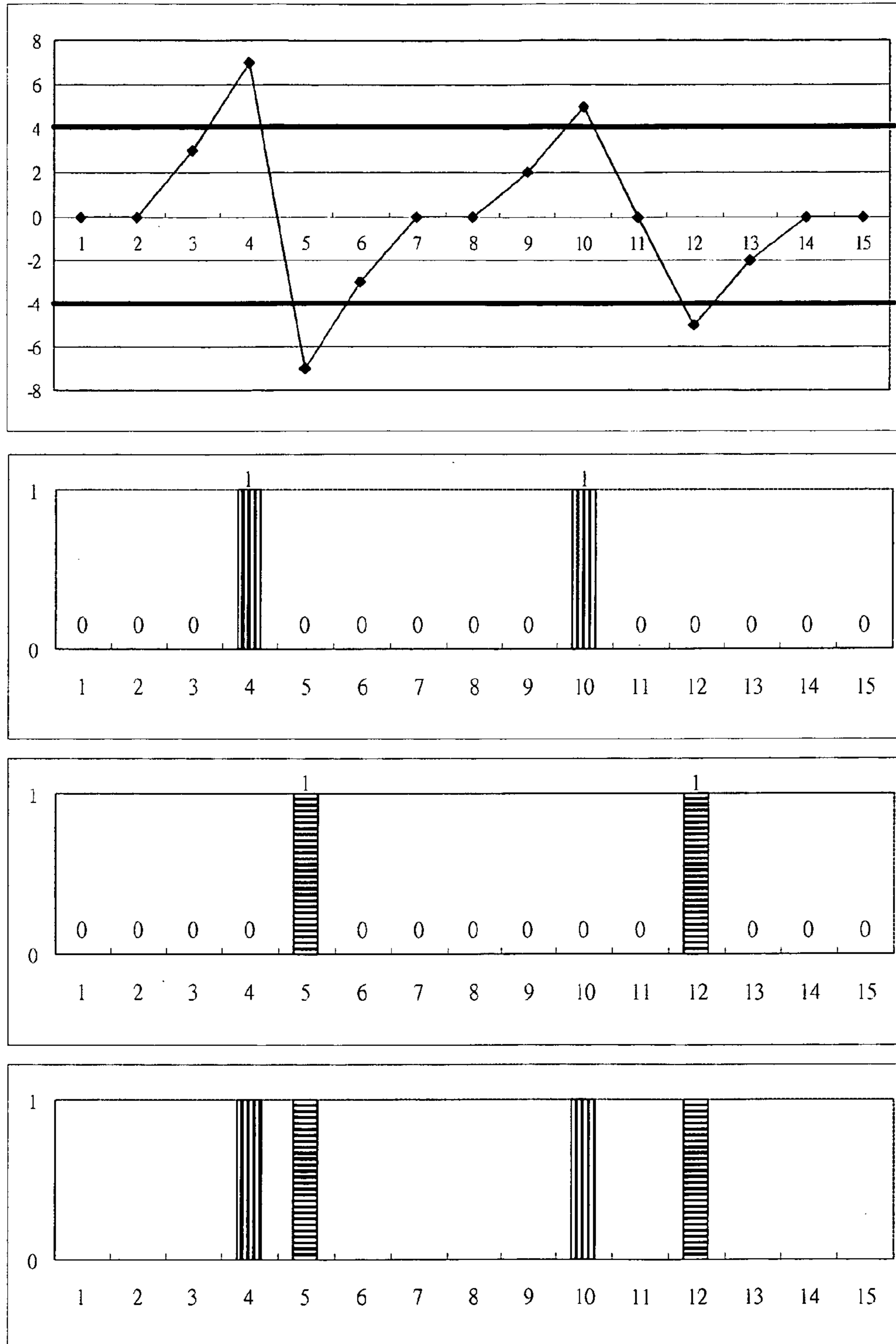

FIG. 4A

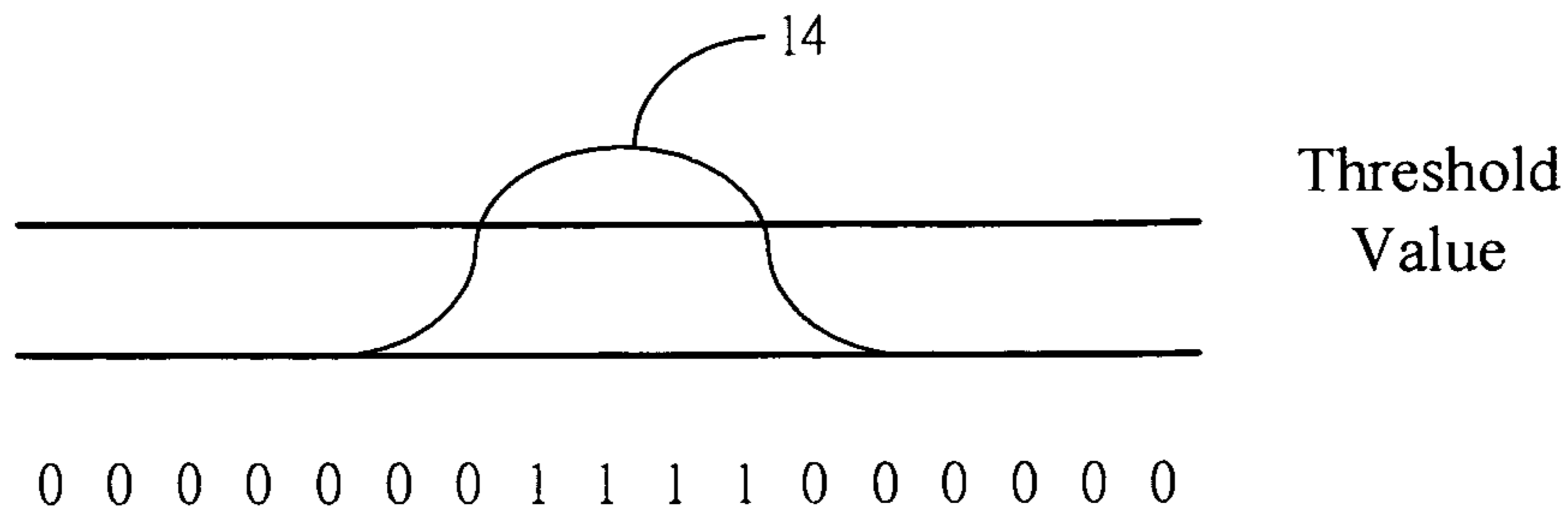

FIG. 4B

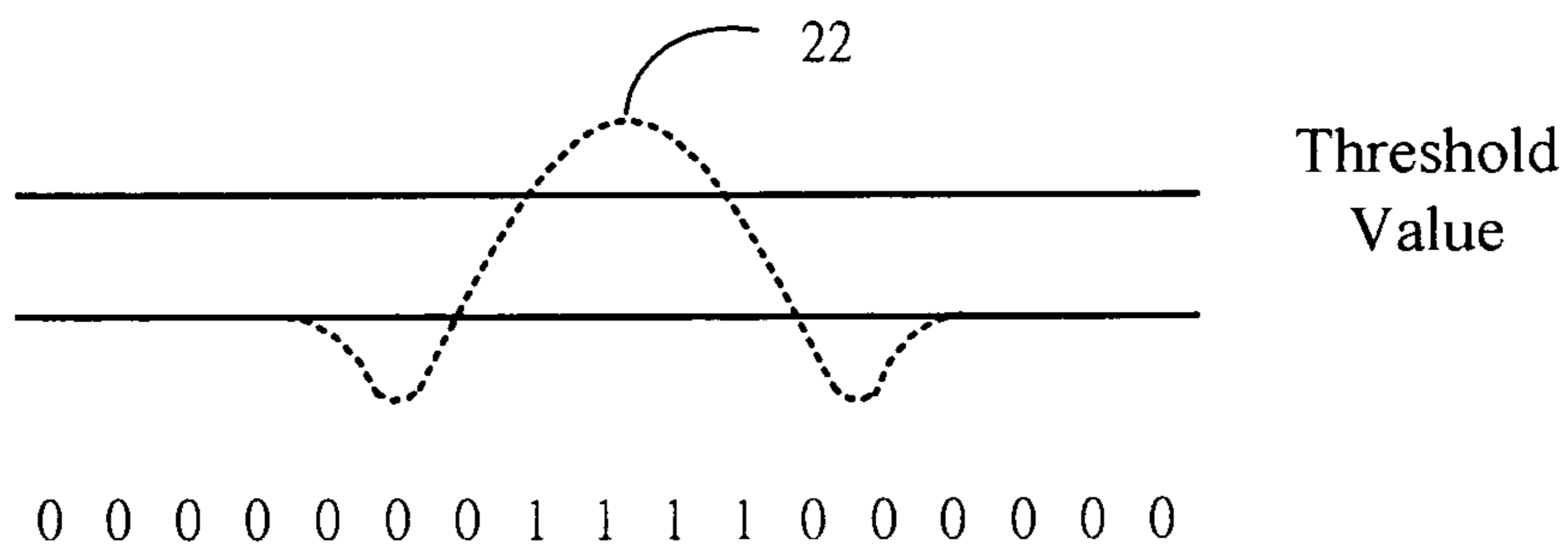

FIG. 4C

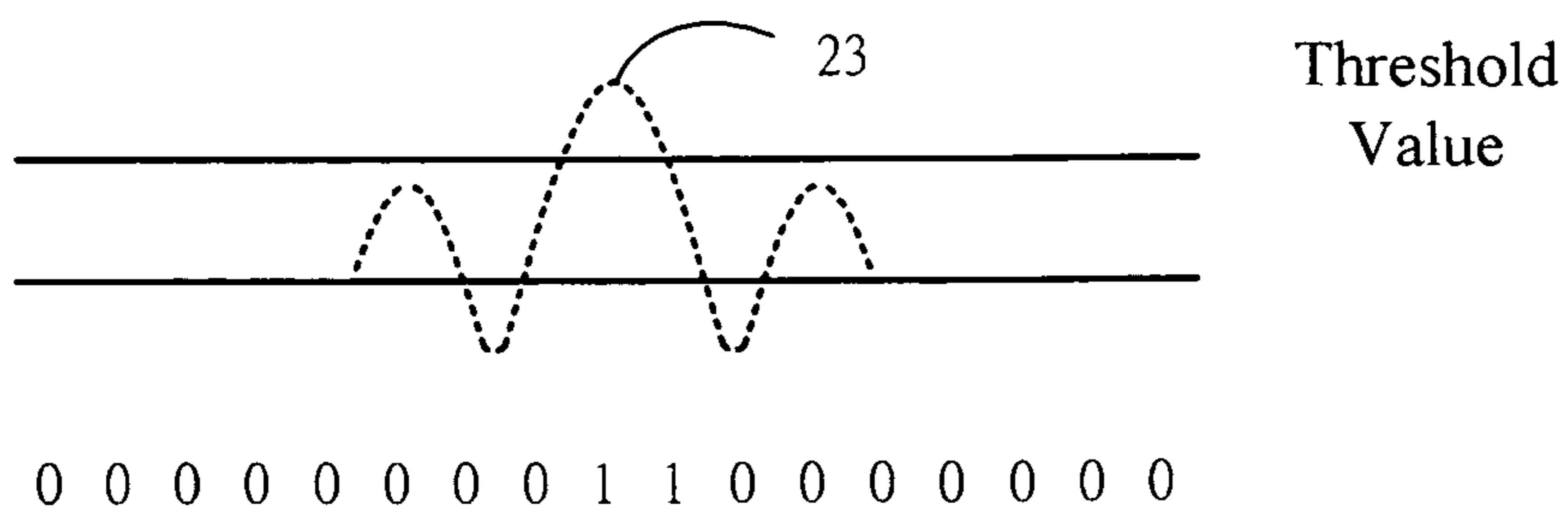

FIG. 4D

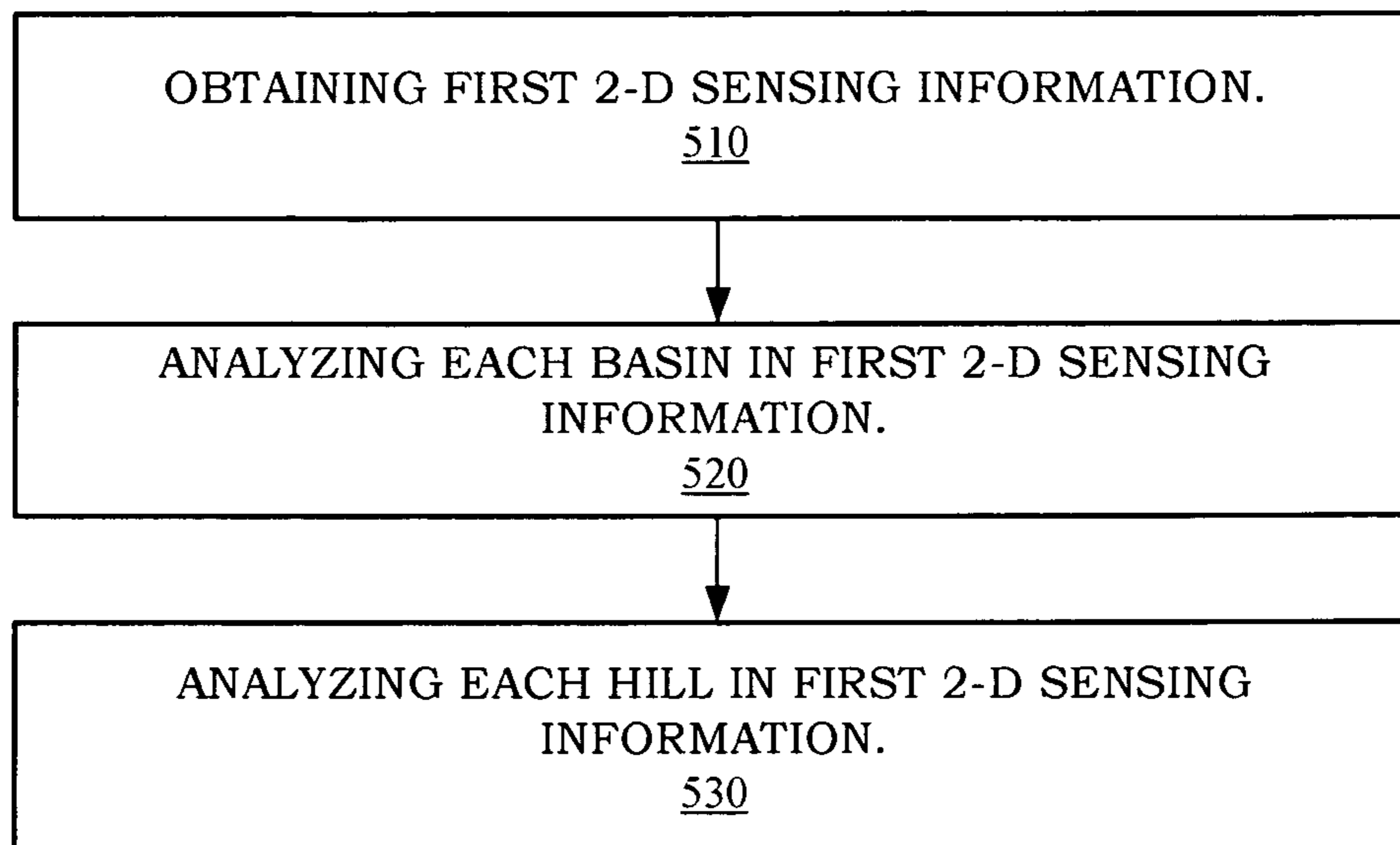

FIG. 5

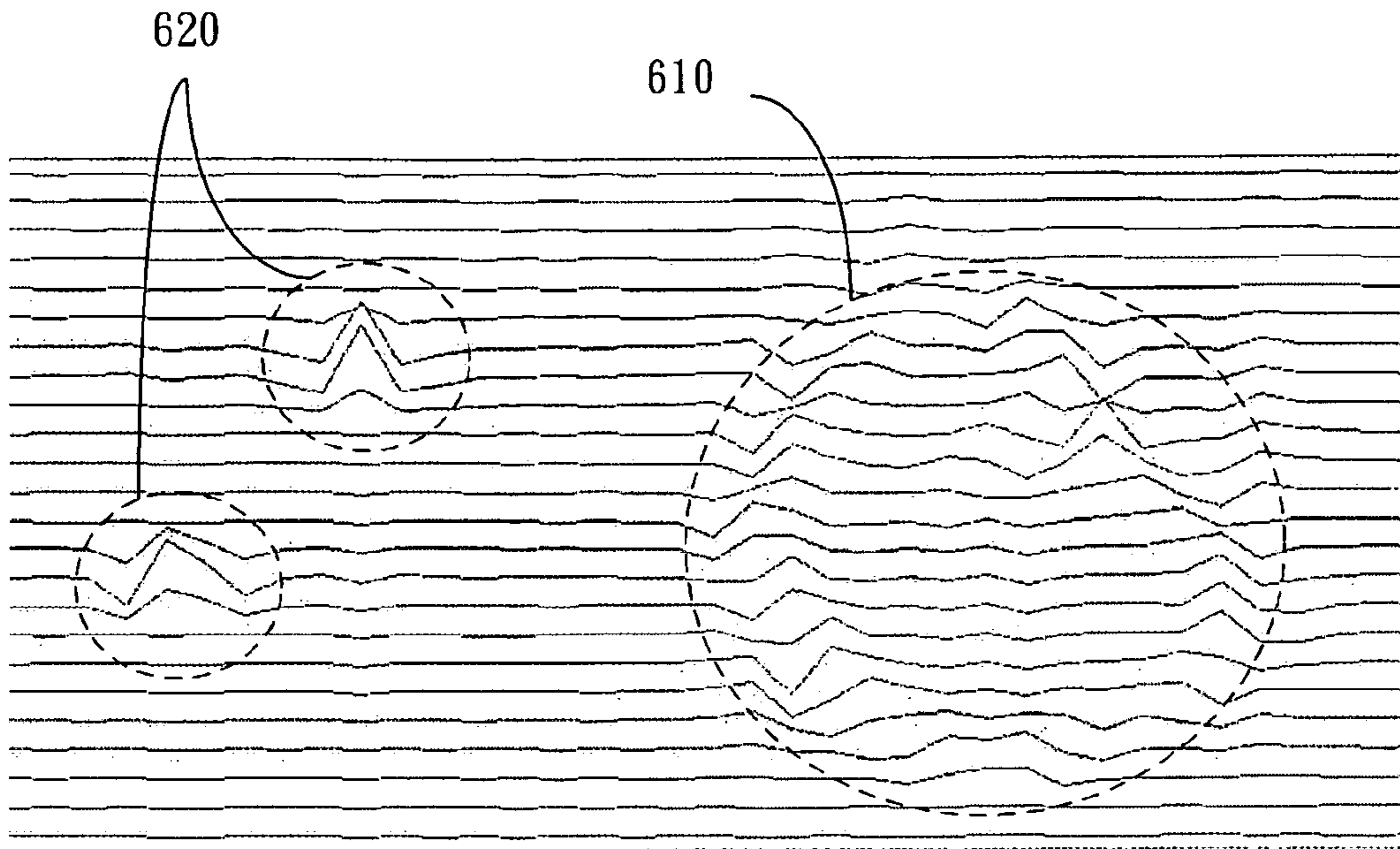

FIG. 6A

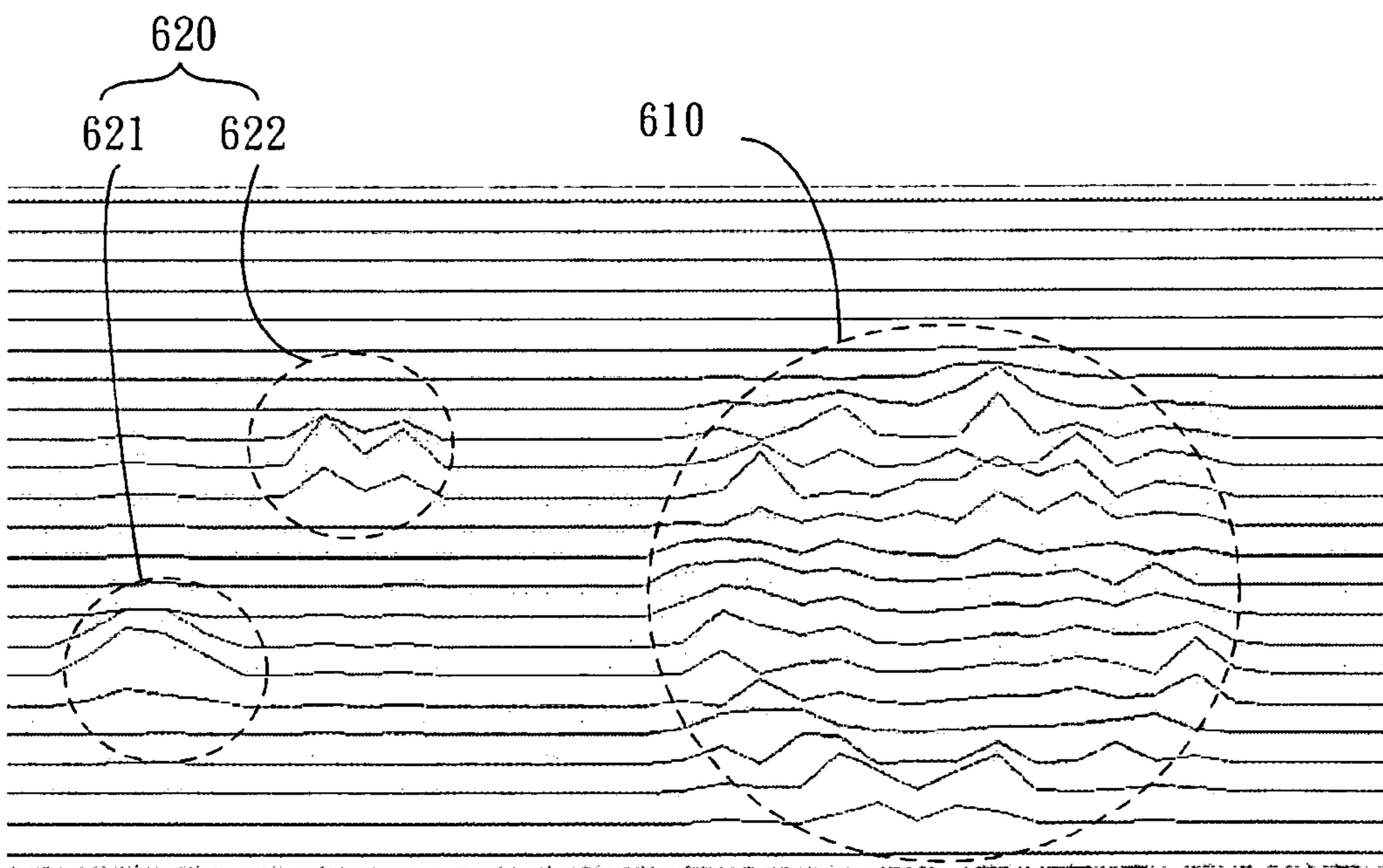

FIG. 6B

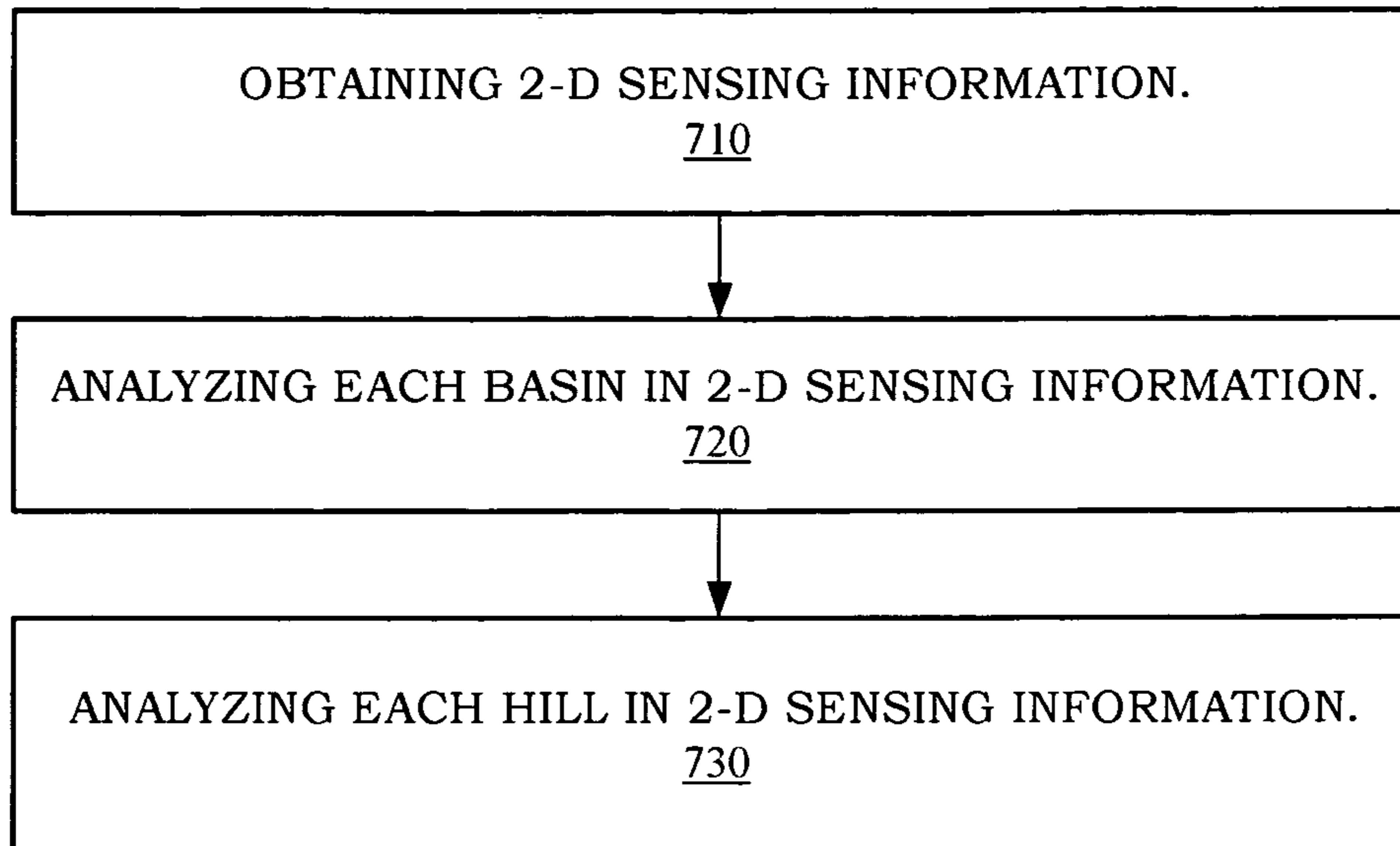

FIG. 7A

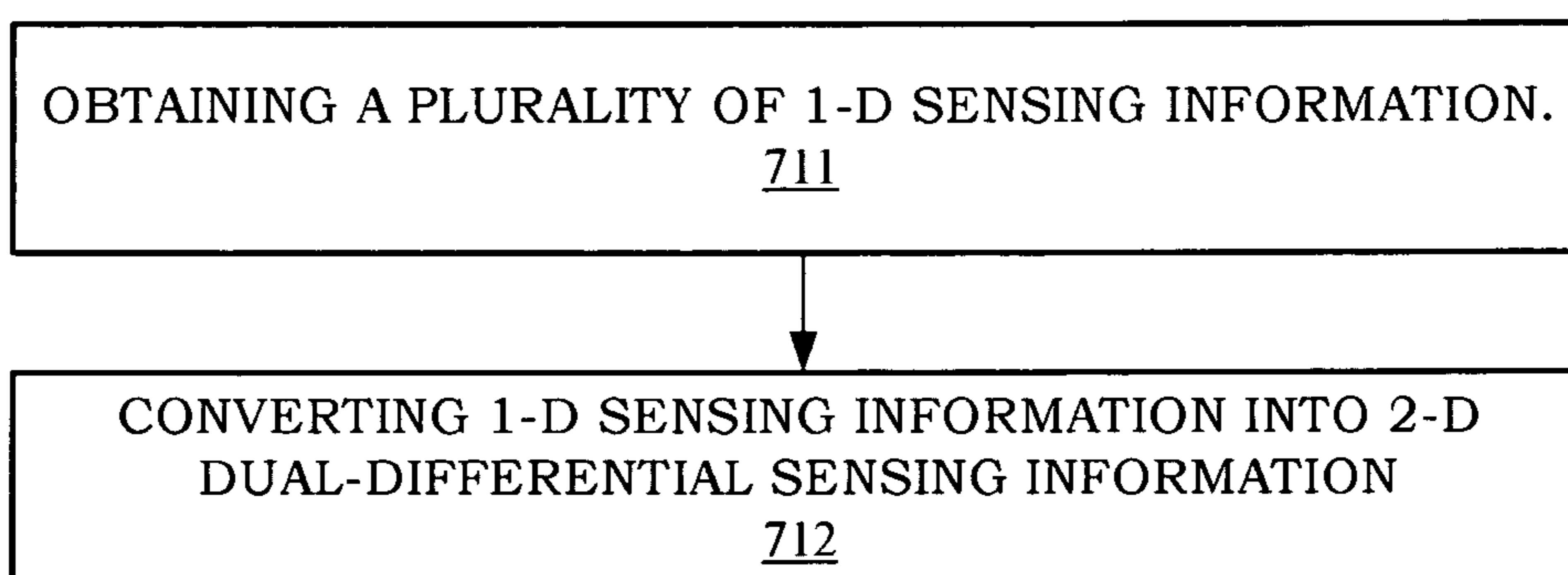

FIG. 7B



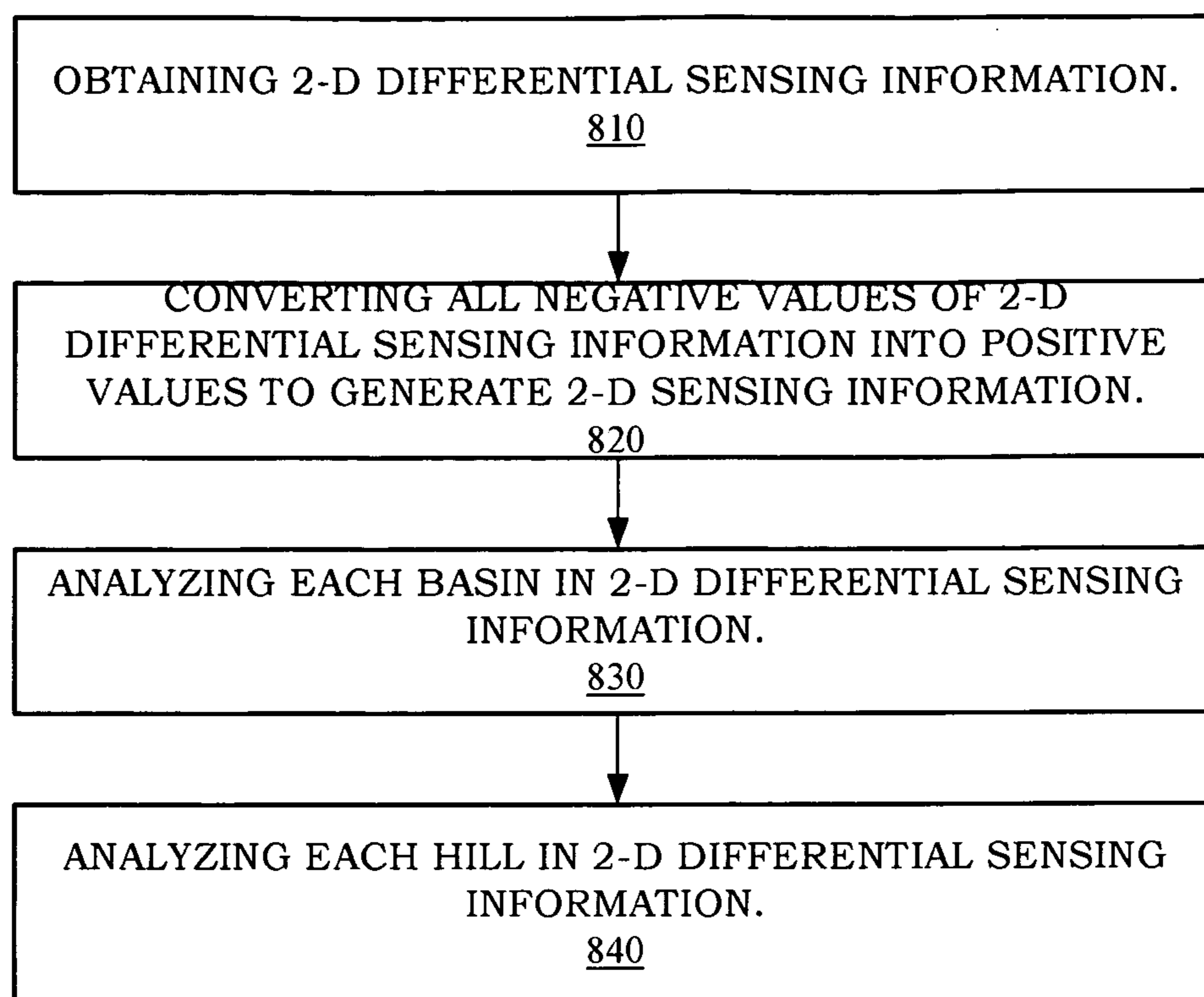

FIG. 8A

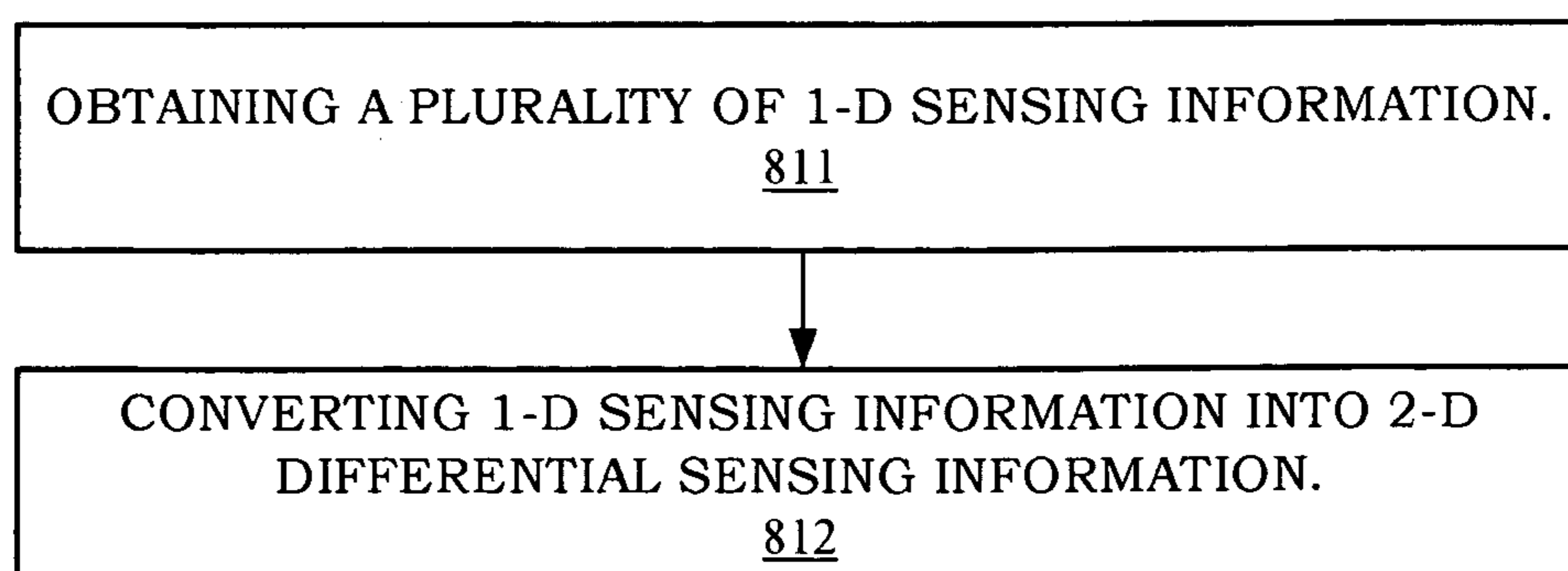

FIG. 8B

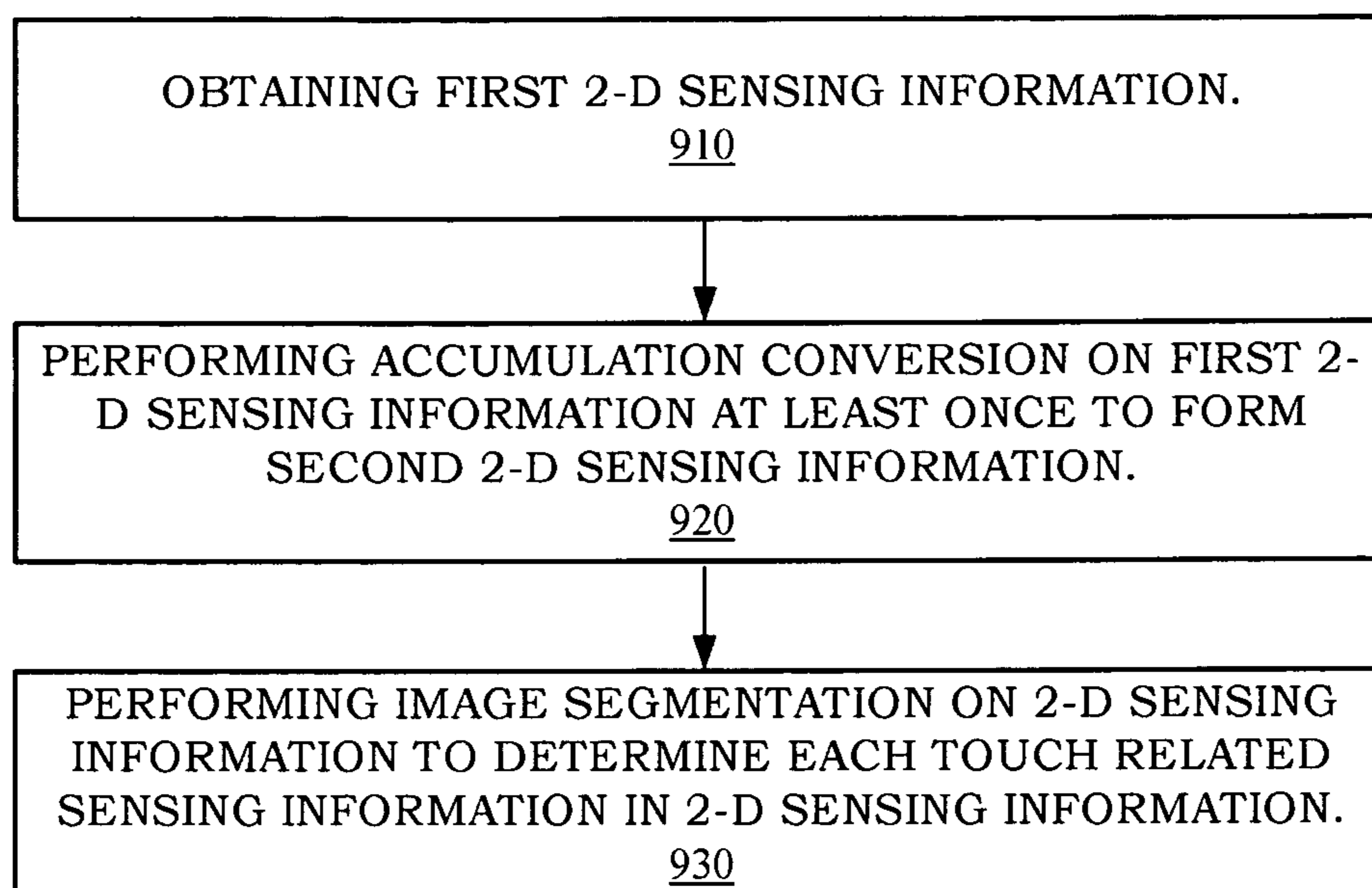

FIG. 9

1

## METHOD AND DEVICE FOR ANALYZING TWO-DIMENSION SENSING INFORMATION

### CROSS REFERENCE TO RELATED APPLICATIONS

This application claims the benefit of U.S. Provisional Application No. 61/298,252, filed on Jan. 26, 2010, Provisional Application No. 61/298,243, filed on Jan. 26, 2010 and U.S. Provisional Application No. 61/250,051, filed on Oct. 9, 2009, which is herein incorporated by reference for all intents and purposes.

### CROSS-REFERENCE TO COMPUTER PROGRAM LISTING APPENDIX

Appendix A contains the following file in one CD-ROM in IBM-PC format and compatible with Microsoft Windows (of which two identical copies are attached hereto). Appendix A is a part of the present disclosure and is incorporated by reference herein in its entirety.

Directory of E:\

Oct. 8, 2010, 127,488 appendix.doc

1 File(s) 127,488 bytes

0 Dir(s) 0 bytes free

The files of Appendix A form source code of computer programs for implementing an illustrative embodiment of the present invention.

### COPYRIGHT NOTICE

A portion of the disclosure of this patent document contains material which is subject to copyright protection. The copyright owner has no objection to the facsimile reproduction by anyone of the patent document or the patent disclosure, as it appears in the patent and trademark office patent files or records, but otherwise reserves all copyright rights whatsoever.

### BACKGROUND OF THE INVENTION

#### 1. Field of the Invention

The present invention relates to a method and device for analyzing two-dimension sensing information, and more particularly, to a method and device for analyzing two-dimension sensing information to determine touch related sensing information with inner lower values within outer high values and with the inner higher values within outer low values.

#### 2. Description of the Prior Art

Touch displays have been widely used in the various electronic devices. One approach is to employ a touch sensitive panel to define a 2-D touch area on the touch display, where sensing information is obtained by scanning along horizontal and vertical axes of the touch panel for determining the touch or proximity of an external object (e.g. a finger) on or near the touch panel. U.S. Pat. No. 4,639,720 discloses a capacitive touch display.

Sensing information can be converted into a plurality of continuous signal values by an analog-to-digital converter (ADC). By comparing signal values before and after the touch or approaching of the external object, the location touched or approached by the external object can be determined.

Generally, a controller controlling the touch panel will first obtain sensing information when there is no external object touching or approaching as a baseline. For example, in a capacitive touch panel, each conductive line corresponds to a

2

respective baseline. The controller determines whether there is an external object touching or approaching by comparing sensing information obtained subsequently with the baseline, and further determines the position of the external object. For example, when there is no external object touching or approaching the touch panel, subsequent sensing information with respect to the baseline will be or close to zero. Thus, the controller can determine whether there is an external object touching or approaching by determining whether the sensing information with respect to the baseline is or close to zero.

As shown in FIG. 1A, when an external object **12** (e.g. a finger) touches or approaches a sensing device **120** of a touch display **10**, sensing information of sensors **140** on an axis (e.g. x axis) is converted into signal values as shown in FIG. 1B. Corresponding to the appearance of the finger, the signal values show a waveform or finger profile. The location of the peak **14** of the finger profile indicates the position touched or approached by the finger.

However, the surface of the touch display will continuously give out various noises. These noises vary with time and position and directly or indirectly affect the signal values, causing errors in position detection, or even positive detections at untouched locations. Furthermore, human body carries many noises, which could equally affect the signal values directly or indirectly.

From the above it is clear that prior art still has shortcomings. In order to solve these problems, efforts have long been made in vain, while ordinary products and methods offering no appropriate structures and methods. Thus, there is a need in the industry for a novel technique that solves these problems.

### SUMMARY OF THE INVENTION

The present invention provides a method and device for position detection. Corresponding to a first touch related sensing information, a second touch related sensing information is acquired for determining at least one position. Each position is used separately for determining the position of a centroid according to the first touch related sensing information or the second touch related sensing information.

The present invention provides to a method and device for analyzing 2-D sensing information. The 2-D sensing information is analyzed to determine touch related sensing information, wherein the touch related sensing information may include touch related sensing information with inner lower values within outer high values and touch related sensing information with the inner higher values within outer low values.

Traditional sensing information is acquired directly from signal values on the sensors, wherein a lot of signal values are affected by noise, which leads to misjudgment of touch locations. Obviously, signals directly from the sensors are not suitable for touch determination.

The present invention includes at least the following objectives:

1. providing 2-D sensing information having touch related sensing information of valley, basins and/or hills;

2. converting 2-D sensing information having touch related sensing information of valley, basins and/or hills into 2-D sensing information including a plurality of quasi signal values;

3. analyzing 2-D sensing information to determine touch related sensing information with inner lower values within outer high values and touch related sensing information with the inner higher values within outer low values; and

4. performing at least one accumulation calculation to generate 2-D sensing information for determining touch related sensing information.

The objectives of the present invention can be achieved by the following technical schemes. A method for analyzing 2-D sensing information proposed by the present invention includes analyzing a first 2-D sensing information to determine each touch related sensing information with inner lower values within outer high values in the first 2-D sensing information. In addition, a device for analyzing 2-D sensing information proposed by the present invention includes a controller and a host for performing an analysis, including: analyzing a first 2-D sensing information to determine each touch related sensing information with inner lower values within outer high values in the first 2-D sensing information converting each touch related sensing information with inner lower values within outer high values into touch related sensing information with inner higher values within outer low values.

The analysis may further include analyzing the first 2-D sensing information to determine each touch related sensing information with inner higher values within outer low values in the first 2-D sensing information. Further, the analysis may further include converting each touch related sensing information with inner higher values within outer low values into touch related sensing information with inner lower values within outer high values, so as to generate 2-D sensing information constituted by a plurality of quasi signal values.

The objectives of the present invention can also be achieved by the following technical schemes. A method for analyzing 2-D dual-differential sensing information proposed by the present invention includes: obtaining a 2-D dual-differential sensing information which includes a plurality of dual differences; and performing an analysis on the 2-D dual-differential sensing information to determine each partial sensing information with inner lower values within outer high values in the 2-D dual-differential sensing information. In addition, a device for analyzing 2-D dual-differential sensing information proposed by the present invention includes a controller and a host for performing an analysis, including: obtaining a 2-D dual-differential sensing information which includes a plurality of dual differences; and performing an analysis on the 2-D dual-differential sensing information to determine each partial sensing information with inner lower values within outer high values in the 2-D dual-differential sensing information.

The analysis may further include analyzing the first 2-D sensing information to determine each touch related sensing information with inner higher values within outer low values in the first 2-D sensing information. Further, the analysis may further include converting each touch related sensing information with inner higher values within outer low values into touch related sensing information with inner lower values within outer high values, so as to generate 2-D sensing information constituted by a plurality of quasi signal values.

The objectives of the present invention can also be achieved by the following technical schemes. A method for analyzing 2-D differential sensing information proposed by the present invention includes: obtaining a 2-D differential sensing information which includes a plurality of differences; converting all the negative values of the 2-D differential sensing information into positive values to generate a 2-D sensing information; and performing an analysis on the 2-D sensing information to determine each partial sensing information with inner lower values within outer high values in the 2-D sensing information. In addition, a device for analyzing 2-D differential sensing information proposed by the present invention includes a controller and a host for performing an

analysis, including: obtaining a 2-D differential sensing information which includes a plurality of dual differences; converting all the negative values of the 2-D differential sensing information into positive values to generate a 2-D sensing information; and performing an analysis on the 2-D sensing information to determine each partial sensing information with inner lower values within outer high values in the 2-D sensing information.

The analysis may further include analyzing the first 2-D sensing information to determine each touch related sensing information with inner higher values within outer low values in the first 2-D sensing information. Further, the analysis may further include converting each touch related sensing information with inner higher values within outer low values into touch related sensing information with inner lower values within outer high values, so as to generate 2-D sensing information constituted by a plurality of quasi signal values.

The objectives of the present invention can also be achieved by the following technical schemes. A method for analyzing 2-D sensing information proposed by the present invention includes: obtaining a first 2-D differential sensing information which includes first 1-D sensing information; performing an accumulation conversion on each of the first 1-D sensing information at least once to generate a second 2-D sensing information, wherein the accumulation conversion converts each value in the 1-D sensing information into an accumulation of the value with all values preceding or following the values; and performing image segmentation on the 2-D sensing information to determine each touch related sensing information in the 2-D sensing information. In addition, a device for analyzing 2-D sensing information proposed by the present invention includes: a controller and a host for performing an analysis, including: obtaining a first 2-D differential sensing information which includes first 1-D sensing information; performing an accumulation conversion on each of the first 1-D sensing information at least once to generate a second 2-D sensing information, wherein the accumulation conversion converts each value in the 1-D sensing information into an accumulation of the value with all values preceding or following the values; and performing image segmentation on the 2-D sensing information to determine each touch related sensing information in the 2-D sensing information.

By aforementioned technical schemes, the present invention achieves at least the following advantages and benefits:

1. Noise interference can be effectively reduced by applying differential sensing information to 2-D analysis.

2. Noise interference can be effectively reduced by applying dual-differential sensing information to 2-D analysis.

3. The present invention is applicable to the traditional method for analyzing 2-D position but has an improved signal-to-noise ratio by converting 2-D differential sensing information or dual-differential sensing information into traditional 2-D sensing information with signal values.

The above description is only an outline of the technical schemes of the present invention. Preferred embodiments of the present invention are provided below in conjunction with the attached drawings to enable one with ordinary skill in the art to better understand said and other objectives, features and advantages of the present invention and to make the present invention accordingly.

#### BRIEF DESCRIPTION OF THE DRAWINGS

The present invention can be more fully understood by reading the following detailed description of the preferred embodiments, with reference made to the accompanying drawings, wherein:

## 5

FIG. 1A is a schematic diagram depicting a prior-art touch sensitive device;

FIG. 1B is a schematic diagram illustrating prior-art signal values;

FIG. 1C is a schematic diagram illustrating differences according to the present invention;

FIGS. 1D and 1E are schematic diagrams illustrating dual differences according to the present invention;

FIG. 1F is a schematic diagram illustrating a sensing device according to the present invention;

FIG. 1G is a block diagram illustrating functions of a computing system according to the present invention;

FIGS. 2A and 2B are schematic diagrams illustrating a driving/detecting unit and a sensing device according to the present invention;

FIG. 3A is a block diagram illustrating functions of a detecting unit according to the present invention;

FIGS. 3B to 3D are circuit diagrams illustrating detectors according to the present invention;

FIGS. 3E to 3J are diagrams showing connections between a detecting circuit and an ADC circuit according to the present invention;

FIG. 4A is a diagram illustrating position detection using binary differences according to the present invention;

FIGS. 4B to 4D are diagrams illustrating examples for detecting centroid positions according to the present invention;

FIG. 5 is a flow chart illustrating a method for analyzing 2-D sensing information according to a first embodiment of the present invention;

FIGS. 6A to 6B are schematic diagrams depicting basins and hills according to the present invention;

FIGS. 7A and 7B are flow charts illustrating a method for analyzing 2-D dual-differential sensing information according to a second embodiment of the present invention;

FIGS. 8A and 8B are flow charts illustrating a method for analyzing 2-D differential sensing information according to a third embodiment of the present invention; and

FIG. 9 is a flow chart illustrating a method for analyzing 2-D sensing information according to a fourth embodiment of the present invention.

#### DETAILED DESCRIPTION OF THE PREFERRED EMBODIMENTS

Some embodiments of the present invention are described in details below. However, in addition to the descriptions given below, the present invention can be applicable to other embodiments, and the scope of the present invention is not limited by such, rather by the scope of the claims. Moreover, for better understanding and clarity of the description, some components in the drawings may not necessary be drawn to scale, in which some may be exaggerated relative to others, and irrelevant parts are omitted.

##### Sensing Information

In the present invention, sensing information can be provided by a touch sensitive device for representing 1-D, 2-D or multi-dimensional statuses on the touch sensitive device. The sensing information can be obtained by one or more sensors and converted into a plurality of continuous signal values by one or more Analog-to-Digital converters to represent among or change in amount of detected charges, current, voltage, capacitance, impedance or other electrical characteristics. Sensing information can be obtained or transmitted alternately, sequentially or in parallel, and can be compounded into one or more signals. These are obvious to those having ordinary skill in the art.

## 6

One having ordinary skill in the art may also recognize that sensing information described in the present invention includes, but not limited to, a signal of a sensor, a result of the signal of the sensors subtracted by a baseline (e.g. a signal when untouched or initial signals), a digitally converted value of said signal or said result of signal subtracted by baseline or said value converted in any other ways. In other words, sensing information can be in the form of a signal status, a status that is converted from any electrical signal or can be converted into electrical signal recorded in a storage medium (e.g. a register, a memory, a magnetic disk, an optical disk), including but not limited to analog or digital information.

Sensing information can be provided by two 1-D sensing information on different axes. The two 1-D sensing information can be used to represent the sensing information on a first axis (e.g. vertical axis) and a second axis (e.g. horizontal axis) on the touch sensitive device. They are used for position detection on the first and second axes, respectively, i.e. providing 1-D positions on the first and second axes or further constructing a 2-D position. In addition, the two 1-D sensing information can also be used for triangulation based on the distances between sensors to detect a 2-D position on the touch sensitive device.

Sensing information can be 2-D sensing information that consists of a plurality of 1-D sensing information on the same axis. The 2-D sensing information can represent signal distribution on a 2-D plane. For example, a plurality of 1-D sensing information on the vertical axis and a plurality of 1-D sensing information on the horizontal axis can represent a signal matrix, such that position detection can be achieved by watershed algorithm or other image processing methods.

In an example of the present invention, the sensing area on the touch sensitive device includes an overlapping range of a first 2-D detecting range detected by at least one first sensor and a second 2-D detecting range detected by at least one second sensor. One with ordinary skill in the art may also recognize that the sensing area can be an overlapping range of three or more 2-D detecting ranges.

For example, the detecting range of a single sensor can be a 2-D detecting range. A sensor (e.g. CCD or CMOS sensor) with camera-based optical detection or a piezoelectric sensor with surface acoustic wave detection obtains 1-D sensing information in the 2-D detecting range. The 1-D sensing information can be comprised of information sensed at a plurality of continuous time points, which correspond to different angles, positions or ranges. In addition, the 1-D sensing information can be generated according to images obtained (e.g. by CCD-CMOS sensor) within a time interval.

Furthermore, for example, the 2-D sensing range can consist of detecting ranges of a plurality of sensors. For example, the detecting range of each infrared photoreceptor, capacitive or resistive conductive bar or strip, or inductive U-shape coil is a fan or stripe shaped detecting range towards one axis. The detecting ranges of a plurality of sensors arranged on the same axis on a line segment (straight or curved) can form a 2-D detecting range of that axis, which can be a square or fan-shaped planar or arc detecting range, for example.

In a preferred example of the present invention, the sensing area on the touch sensitive device includes a 2-D range detected by a plurality of sensors on the first and second axes. For example, through self-capacitive detection, a driving signal is provided to a plurality of first sensors, and capacitive-coupling signals or changes in said signal in a 2-D detecting range of these first sensors are sensed to obtain first 1-D sensing information. Furthermore, a driving signal is provided to a plurality of second sensors, and capacitive-cou-

pling signals or changes in said signal in a 2-D detecting range of these second sensors are sensed to obtain second 1-D sensing information.

In another example of the present invention, the sensing area on the touch sensitive device involves a plurality of sensors detecting a plurality of 1-D sensing information in a 2-D sensing range to construct 2-D sensing information. For example, when a signal source sequentially applies a driving signal to sensors on a first axis, signal(s) of at least one of sensors in a second axis is sequentially detected or on a plurality of sensors (partially or all) are simultaneously detected to obtain 2-D sensing information on the axis, wherein the sensors are adjacent or not adjacent but neighboring sensors on the second axis. For example, in mutual-capacitive detection or analog matrix resistive detection, a plurality of sensors constitute a plurality of sensing areas for detecting sensing information at each respective area. For example, a plurality of first sensors (e.g. a plurality of first conductive lines) and a plurality of second sensors (e.g. a plurality of second conductive lines) intersect with each other to form a plurality of overlapping regions. When a driving signal is sequentially provided to each of the first sensors, corresponding to the first sensor being driven by the driving signal, signal(s) or changes in signal(s) on at least one of the second sensors on the second axis is sequentially detected or on a plurality of the second sensors (partially or all) on the second axis are simultaneously detected to obtain 1-D sensing information corresponding to that first sensor. By collecting 1-D sensing information corresponding to each of the first sensors together, 2-D sensing information can be constructed. In an example of the present invention, 2-D sensing information can be regarded as an image.

One with ordinary skill in the art can appreciate that the present invention can be applied to touch sensitive display, for example, a display attached with aforementioned resistive, capacitive, surface acoustic wave, or other touch detection device (or referred to as touch sensitive device). Thus, sensing information obtained by the touch sensitive display or device can be regarded as touch sensitive information.

In an example of the present invention, a touch sensitive device may use continuous signals from different time points, that is, composite signal continuously detected by one sensor or simultaneously by a plurality of sensors. For example, the touch sensitive device may be inductive and continuously scan coils thereon to emit electromagnetic waves. Meanwhile, sensing information is detected by one or more sensors on an electromagnetic pen and continuously compounded to form a signal. This signal is then converted into a plurality of continuous signal values by an ADC. Alternatively, electromagnetic waves are emitted by an electromagnetic pen or electromagnetic waves from an inductive touch sensitive device are reflected, and sensing information is obtained by a plurality of sensors (coils) on the touch sensitive device.

#### Touch Related Sensing Information

When an external object (e.g. a finger) touches or approaches a touch sensitive device, electrical characteristic or changes will be generated by sensing information at an area corresponding to the touch or proximity of the object. The larger the electrical characteristic or changes, the closer it is to the center (e.g. centroid, center of gravity of center of geometry) of the external object. Continuous sensing information can be regarded as constituted by a plurality of continuous values whether it is digital or analog. The center of the external object may correspond between one or two values. In the present invention, a plurality of continuous values can be spatially or temporally continuous.

A first type of 1-D sensing information provided by the present invention is in the form of a plurality of continuous signal values, which can be signal values detected by a plurality of sensors in a time interval, by a single sensor in a continuous time interval or by a single sensor in a single time interval at different detecting locations. In the process of representing sensing information as signal values, signals from respective sensors, time intervals or locations are sequentially converted into signal values, or part or all of sensing information is obtained, thereafter, respective signal values are then analyzed. When an external object touches or draws near to a sensing device, continuous signal values of 1-D sensing information can be those as shown in FIG. 1B. Position touched by the external object corresponds to the peak **14** of the sensing information, wherein peak **14** may reside between two signal values. As described earlier, the present invention does not limit the form of sensing information. Signal values can be another form of the signals of the sensors. For brevity of the description, the present invention below is described in the context of implementations of the signal values. One with ordinary skill in the art may appreciate the implementations of signals from the implementations of signal values.

A second type of 1-D sensing information provided by the present invention is in the form of a plurality of continuous differences, compared to the signal values above, each difference is the difference of a pair of signal values, and the sensing information represented by a plurality of differences can be regarded as differential sensing information. In the present invention, differential sensing information can be obtained directly during sensing, for example, simultaneously or continuously obtaining a plurality of signals, each difference being generated based on a differential signal corresponding to a pair of sensor, time intervals, or locations. The differential sensing information can be generated based on the original sensing information including a plurality of signal values generated previously. As described earlier, the present invention does not limit the form of sensing information. Differences can be another form of the differential signals. For brevity of the description, the present invention below is described in the context of implementations of the differences. One with ordinary skill in the art may appreciate the implementations of differential signals from the implementations of differences.

In an example of the present invention, a difference can be the difference between a pair of adjacent or not adjacent signal values, for example, the difference between a signal value and its immediately preceding signal value, or between a signal value and its following signal value. In another example of the present invention, the difference can be the difference between non-adjacent signal values. When an external object touches or draws close to the touch sensitive device, continuous differences of 1-D sensing information can be those shown in FIG. 1C, wherein the position of the external object corresponds to zero-crossing **15** of the sensing information. Zero-crossing **15** may reside between two signal values. In an example of the present invention, on the touch sensitive device, the location of each difference is the middle of the two corresponding signal values.

A third type of 1-D sensing information provided by the present invention is in the form of a plurality of continuous dual differences, compared to the signal values and differences above, each dual difference can be the sum or difference of the difference for a first pair of signal values and the difference for a second pair of signal values, that is, the sum or difference of the differences of two pairs of signal values. For example, two pairs of signal values include a first signal

value, a second signal value, a third signal value, and a fourth signal value. The dual difference for these four signals is (second signal value–first signal value)+(third signal value–fourth signal value), (second signal value–first signal value)–(fourth signal value–third signal value), (first signal value–second signal value)+(fourth signal value–third signal value) or (first signal value–second signal value)–(third signal value–fourth signal value). In addition, sensing information represented by continuous dual differences can be regarded as dual-differential sensing information. In the present invention, a dual difference is not limited to being provided after signal values or differences, but can also be provided through the sum or difference after subtraction of two pairs of signals upon sensing information being provided, providing dual differential signal similar or equivalent to the sum or difference of the differences between two pair of signal values. As described earlier, the present invention does not limit the form of sensing information. Dual differences can be another form of the dual differential signals. For brevity of the description, the present invention below is described in the context of implementations of the dual differences. One with ordinary skill in the art may appreciate the implementations of dual differential signals from the implementations of dual differences.

In an example of the present invention, when the external object touches or approaches the touch sensitive device, two pairs of signal values are constituted by three adjacent or non-adjacent signal values. In an example of the present invention, the differences between the prior two signal values and the latter two signal values are a first difference and a second difference, respectively, and the dual difference is the difference between the first difference and the second difference, wherein the first difference and the second difference both can be the results of the preceding signal value minus the following signal value or the following signal value minus the preceding signal value. In another example of the present invention, the differences between the first two signal values and the last two signal values are a first difference and a second difference, respectively, and the dual difference is the sum of the first difference and the second difference, wherein one of the first difference and the second difference is the result of the preceding signal value minus the following signal value, whereas the other one of the first difference and the second difference is the result of the following signal value minus the preceding signal value. For example, two pairs of signal values include a first signal, a second signal, and a third signal. The dual difference for these three signal values is (second signal value–first signal value)+(second signal value–third signal value), (second signal value–first signal value)–(third signal value–second signal value), (first signal value–second signal value)+(third signal value–second signal value), or (first signal value–second signal value)–(second signal value–third signal value). When two pairs of signal values are constituted by three adjacent signal values, and an external object touches or approaches the touch sensitive device, the continuous dual differences of 1-D sensing information can be those shown in FIG. 1D, wherein the position of the external object corresponds to middle peak **16** of the sensing information. Middle peak **16** may reside between two signal values. When two pairs of signal values are constituted by three non-adjacent signal values, and an external object touches or approaches the touch sensitive device, the continuous dual differences of 1-D sensing information can be those shown in FIG. 1E, wherein the position of the external object corresponds to middle peak **17** of the sensing information. Middle peak **17** may reside between two signal values.

In the present invention, sensing information corresponding to respective sensor, time interval or position can be signals detected by the sensors. When the signals are analog, it can be converted into digital signal values by an ADC. Thus, the above difference can also be the value of the difference between a pair of signals, for example, value converted from a pair of signals subtracted via a differential amplifier. Similarly, the above dual difference can also be the value converted from two pairs of signals subtracted via a differential amplifier and then added (or subtracted) together. One with ordinary skill in the art can appreciate that the difference and dual difference described by the present invention not only include being generated by signals or signal values, but also include temporary states of records (electrical, magnetic or optical records), signals or signal values during hardware or software implementations.

In other words, sensing information can be signals, differential signals (e.g. difference between a pair of signals), dual differential signals (e.g. sum or difference of two pairs of signals) on or between the sensors, and signal values, differences, dual differences (analog-to-digital converted signal values, differences or dual differences) can be another form. Signals and signal values, differential signals and differences, and dual differential signals and dual differences are sensing information represented at different stages. In addition, for brevity of the description, touch related sensing information mentioned herein broadly refers to sensing information corresponding to touch or proximity of an external object, such as original touch related sensing information, differential touch related sensing information and dual-differential touch related sensing information.

One with ordinary skill in the art can appreciate that in the case of differences or dual differences, zero-crossing is between at least one positive value and at least one negative value that is between a pair of positive and negative values. The difference or dual difference that corresponds to the touch or proximity of the external object may be an alternating continuous combination of at least one positive value and at least one negative value, wherein at least one zero value is interposed between the at least one positive value and at least one negative value. In most cases, the difference or dual difference that corresponds to the touch or proximity of the external object is an alternating continuous combination of multiple positive values and multiple negative values, wherein zero-crossings between positive and negative values may be at least a zero value or between two values.

In contrast, touch related signal values include a plurality of continuous non-zero values, or an independent non-zero value not adjacent to other non-zero values. In some cases, an independent non-zero value not adjacent to other non-zero values may be generated by noise, which should be identified and neglected by thresholding or other types of mechanisms.

Since noise could generate zero-crossing similar to the touch or proximity of an external object when large, thus in an example of the present invention, values that fall within a zero-value range will be treated as zero values. Difference or dual difference corresponding to the touch or proximity of an external object is an alternating continuous combination of multiple values above a positive threshold and multiple values below a negative threshold, wherein a zero-crossing between a value above the positive threshold and a value below a negative threshold may be at least one zero value or between two values.

In summary of the above, differential touch related sensing information and dual-differential touch related sensing information are alternating continuous combinations of at least one positive value and at least one negative value including a

## 11

zero-crossing, wherein the zero-crossing can be at least one zero value or between the positive and negative values. In other words, a plurality of continuous zero values between positive and negative values in the differential touch related sensing information and dual-differential touch related sensing information are treated as zero-crossings, or one of which is treated as a zero-crossing.

In an example of the present invention, touch related sensing information is set to begin with at least a positive or negative value, and from there an alternating continuous combination of at least one positive value and at least one negative value including a zero-crossing is searched, wherein the zero-crossing may be at least one zero value or between positive and negative values. In differential touch related sensing information, alternating combinations of at least one positive value and at least one negative value occur symmetrically, and in dual-differential touch related sensing information, alternating combinations of at least one positive value and at least one negative value do not occur symmetrically. In an example of the present invention, touch related sensing information is continuous non-zero values, e.g. a plurality of continuous non-zero signal values.

The at least one positive value above can be regarded as a positive-value set including at least one positive value. Similarly, the at least one negative value above can be regarded as a negative-value set including at least one negative value. Thus, the above alternating combination can be a combination of two sets: a positive-value set and a negative-value set, or a combination of three or more set with alternating positive-value and negative-value sets. In an example of the present invention, at least one zero value may exist between zero, one, or multiple positive-value and negative-value sets.

System Framework  
In order to more clearly illustrate how sensing information of the present invention is generated, the present invention uses a capacitive touch sensitive device as an example, and one with ordinary skill in the art can readily recognize other applications such as in resistive, infrared, surface acoustic wave, or optical touch sensitive devices.

Referring to FIG. 1F, the present invention provides a position detecting device 100. As shown, the device includes a sensing device 120 and a driving/detecting unit 130. Sensing device 120 has a sensing layer. In an example of the present invention, the sensing layer can include a first sensing layer 120A and a second sensing layer 120B. First and second sensing layers 120A and 120B each has a plurality of sensors 140, wherein first sensors 140A of first sensing layer 120A cross upon second sensors 140B of second sensing layer 120B. In another example of the present invention, first and second sensors 140A and 140B are disposed in a co-planar sensing layer. Driving/detecting unit 130 produces sensing information based on signals of sensors 140. In the case of self-capacitive detection, for example, sensors 140 driven are sensed. In the case of mutual-capacitive detection, some of sensors 140 not directly driven by driving/detecting unit 130 are sensed. In addition, sensing device 120 can be disposed on a display 110. An optional shielding layer (not shown) can be interposed between sensing device 120 and display 110.

The position detecting device 100 of the present invention can be applied to a computing system as shown in FIG. 1G, which includes a controller 160 and a host 170. The controller includes driving/detecting unit 130 to operatively couple sensing device 120 (not shown). In addition, controller 160 can include a processor 161 for controlling driving/detecting unit 130 in generating sensing information. Sensing information can be stored in a memory 162 and accessible by processor 161. Moreover, host 170 constitutes the main body of the

## 12

computing system, mainly includes a central processing unit 171, a storage unit 173 that can be accessed by central processing unit 171, and display 110 for displaying results of operations.

In another example of the present invention, there is a transmission interface between controller 160 and host 170. The controlling unit transmits data to the host via the transmission interface. One with ordinary skill in the art can appreciate that the transmission interface may include, but not limited to, UART, USB, I<sup>2</sup>C, Bluetooth, Wi-Fi wireless or wired transmission interfaces. In an example of the present invention, data transmitted can be position (e.g. coordinates), identification results (e.g. gesture codes), command, sensing information or other information provided by controller 160.

In an example of the present invention, sensing information can be initial sensing information generated under the control of processor 161, and position analysis is carried out by host 170, such as position analysis, gesture identification, command identification etc. In another example of the present invention, sensing information can be analyzed by processor 161 first before forwarding determined position, gesture or command etc. to host 170. The present invention does not limit to this example, and one with ordinary skill in the art can readily recognize other interactions between controller 160 and host 170.

Referring to FIG. 2A, in an example of the present invention, driving/detecting unit 130 may include a driving unit 130A and a detecting unit 130B. The plurality of sensors 140 of sensing device 120 are operatively coupled to driving/detecting unit 130 via a plurality of wires. In the example of FIG. 2A, driving unit 130A and detecting unit 130B are operatively coupled to sensors 140A via wires W1 and to sensors 140B via wires W2.

For example, in self-capacitive detection, all sensors 140A are sequentially or simultaneously driven or some of sensors 140A are driven simultaneously in batch by driving unit 130A via wires W1 in a first time period. Sensing information of a first axis (1-D sensing information) is generated via wires W1 by detecting unit 130 based on signals of sensors 140A. Similarly, all sensors 140B are sequentially or simultaneously driven or some of sensors 140A are driven simultaneously in batch by driving unit 130A via wires W2 in a second time period. Sensing information of a second axis (1-D sensing information) is generated via wires W2 by detecting unit 130 based on signals of sensors 140B.

For example, in mutual-capacitive detection, sensors 140B are driven by driving unit 130 via wires W2 in a first time period, and when each sensor 140B is respectively driven, 1-D sensing information corresponding to a first axis of the driven sensors is generated by detecting unit 130B based on signals of sensors 140A via wires W1. These 1-D sensing information on the first axis construct 2-D sensing information (or an image) on the first axis. Similarly, sensors 140A are driven by driving unit 130 via wires W1 in a second time period, and when each sensor 140A is respectively driven, 1-D sensing information corresponding to a second axis of the driven sensors is generated by detecting unit 130B based on signals of sensors 140B via wires W2. These 1-D sensing information on the second axis construct 2-D sensing information (or an image) on the second axis. In addition, driving unit 130A and detecting unit 130B can be synchronized via lines 132 by providing signals. The signals on lines 132 can be provided by said processor 160.

Referring to FIG. 2B, sensor device 120 can also generate 2-D sensing information on only a single axis. In this example, sensors 140B are driven by wires W2, and when each sensor 140B is respectively driven, 1-D sensing infor-



mation of the driven sensor is generated by detecting unit **130B** based on the signals of sensors **140A** via wires **W1**. These 1-D sensing information constitute 2-D sensing information (or an image).

In other words, position detecting device **100** of the present invention is capable of producing 1-D sensing information in 2 axes or 2-D sensing information in 2 axes, producing both 1-D and 2-D sensing information in 2 axes, or producing 2-D sensing information in a single axis. The present invention may include but not limited to said capacitive position detecting device, one with ordinary skill in the art can appreciate other applications, such as in resistive, capacitive, surface acoustic wave, or other touch sensitive device.

Referring to FIG. **3A**, detecting unit **130B** is operatively coupled to the sensing device via wires (e.g. **W1**). The operative coupling can be achieved by a switching circuit **310**, which can be one or more electrical elements such as multiplexers and/or switches. One with ordinary skill in the art can recognize other use of switching circuits. Signals of sensors **140** can be detected by a detecting circuit **320**. When signal output by detecting circuit **320** is analog, it is then passed through ADC circuit **330** to generate sensing information **SI**. Sensing information **SI** can be analog or digital. In a preferred example of the present invention, sensing information is digital, but the present invention is not limited to the above example. One with ordinary skill in the art can appreciate that detecting circuit **320** and ADC circuit **330** can be integrated in one or more circuits.

Detecting circuit **320** can be comprised of one or more detectors, each receiving a signal from at least one sensor **140** and generating an output. The detectors can be detectors **340**, **350** and **360** shown in FIGS. **3B** to **3D**.

In an example of the present invention, the detection of the signals of sensors **140** can be achieved by an integrator. One with ordinary skill in the art can appreciate other circuits that measure electrical characteristics (e.g. voltage, current, capacitance, induction etc.), such as an ADC, can be applied to the present invention. An integrator can be implemented by an amplifier **Cint**, which includes an input (e.g. as shown by integrator **322** of FIG. **3B**) or a pair of input (e.g. as shown by integrator **324** of FIGS. **3C** and **3D**) and an output. Output signal can be used by ADC circuit **330** to generate values of sensing information **SI**, each of these values can be controlled by a reset signal, such as a reset signal **Sreset** shown in FIGS. **3B** to **3D**.

In another example of the present invention, signals of sensors **140** are AC signals that vary with a pair of half cycles. Thus, the detection of the signals of sensors **140** also changes with different half cycles. For example, signals of sensors **140** are detected in the prior half cycle, and inverse signals of sensors **140** are detected in the latter half cycle, or vice versa. Therefore, the detection of the signals of sensors **140** can be controlled by a synchronizing signal **Ssync**, as shown in FIGS. **3B** to **3C**. Synchronizing signal **Ssync** and the signals of sensors **140** are in sync or having the same cycle. For example, synchronizing signal **Ssync** is used to control one or more switches (e.g. switching circuits **321**, **323**, **325**) to switch between base points **P1** and **P2**, so as to detect the signals of sensor **140** in the prior half cycle, and to detect the inverse signals of sensor **140** in the latter half cycle. In FIG. **3B**, the inverse signals are provided by an inverter **Cinv**.

In yet another example of the present invention, the detection of the signals of sensors **140** is performed in at least a predetermined time interval (or phase) in at least a cycle. Detection can be done in at least an interval in the first half cycle and at least an interval in the second half cycle; or in at least an interval in only the first or second half cycle. In a

preferred example of the present invention, at least a preferred time interval in a cycle is scanned as the detection interval, wherein noise interference in this detection interval is smaller than in other intervals. Scanning of the detection interval can be determined by the detection of the signal of at least one sensor in each interval in at least a cycle. Upon determining a detection interval, detection of the signals of sensors is performed only in that detection interval, and this can be controlled by a signal, such as an enable signal **Senable** in FIGS. **3B** to **3D**.

The present invention generates the values of sensing information **SI** based on the signal of at least one sensor **140**. In an example of the present invention, sensing information **SI** consists of a plurality of signal values. As shown in FIG. **3B**, an input **311** is operatively coupled to a sensor **140** for detecting a signal and a signal value of sensing information **SI** is generated through ADC circuit **330**. In another example of the present invention, sensing information **SI** consists of a plurality of differences. As shown in FIG. **3C**, a pair of inputs **312** and **313** are operatively coupled to a sensor **140** for detecting a differential signal and a difference (or single difference) of sensing information **SI** is generated through ADC circuit **330**. In yet another example of the present invention, sensing information **SI** consists of a plurality of dual differences. As shown in FIG. **3D**, three inputs **314**, **315** and **316** are operatively coupled to a sensor **140** for detecting a dual differential signal and a dual difference of sensing information **SI** is generated through ADC circuit **330**. A dual differential signal is generated from the difference between a pair of differential signals; each differential signal is generated based on signals of a pair of sensors. In other words, a dual differential signal is generated based on signals of a first pair of sensors and a second pair of sensors, wherein the first pair of sensors are the first two sensors in the three sensors, and the second pair of sensors are the latter two sensors in the three sensors; these three sensors can be adjacent or not adjacent.

In a preferred example of the present invention, detecting circuit **320** includes a plurality of detectors, which simultaneously generate all or some values of sensing information **SI**. As shown in FIGS. **3E** to **3J**, detecting circuit **320** can comprise of a detector **340**, **350** or **360**. The output of the detector is then converted into values of sensing information **SI** by ADC circuit **330**.

ADC circuit **330** includes at least one ADC. Each ADC may output values of sensing information **SI** based on an output of only one detector, as shown in FIGS. **3E**, **3G** and **3I**. Alternatively, an ADC may output values of sensing information **SI** based on outputs of several detectors in turn, as shown in FIGS. **3F**, **3H** and **3J**. Values of sensing information **SI** can be generated in parallel or in series. In a preferred example of the present invention, values of sensing information **SI** are generated in series, which can be achieved by a switching circuit **370**, for example, by outputting values of sensing information **SI** from a plurality of ADCs in turn, as shown in FIGS. **3E**, **3G**, and **3I**, or by providing outputs of a plurality of integrators to a single ADC in turn to generate values of sensing information **SI**, as shown in FIGS. **3F**, **3H** and **3J**.

Accordingly, in an example of the present invention, sensing information **SI** having a plurality of signal values are generated based on signals of a plurality of sensors, wherein each signal value is generated based on a signal from a sensor, as shown in FIGS. **3B**, **3E** and **3F**. In another example of the present invention, sensing information **SI** having a plurality of differences are generated based on signals of a plurality of sensors, wherein each difference is generated based on signals from a pair of sensors, as shown in FIGS. **3C**, **3G** and **3H**. In yet another example of the present invention, sensing infor-

mation SI having a plurality of dual differences are generated based on signals of a plurality of sensors, wherein each dual difference is generated based on signals from three sensors, as shown in FIGS. 3D, 3I and 3J.

In FIGS. 3E to 3J, wires connecting the detectors may include but not limited to wires W1 and wires W2. Connection between an integrator and a wire can be direct or indirect through a switching circuit, as shown in FIG. 3A. In an example of the present invention, values of sensing information are generated by multiple detections by at least a detector of detecting circuit 320. Detecting circuit 320 selects some of the sensors for detection by using switching circuit 310. In addition, only selected sensors are driven by driving unit 130A, for example, in self-capacitive detection. Moreover, only selected sensors and some sensors adjacent to the selected sensors are driven by driving unit 130A.

In a first example of the present invention, the sensing information can be obtained by a dual-differential circuit, which includes: a first-stage differential circuit, a second-stage differential circuit and a measuring circuit, as shown in FIG. 3D, 3I or 3J.

The first-stage differential circuit includes a pair or a plurality of first subtractors (e.g. differential amplifiers in switching circuits 325). Each of first subtractors generates a first-stage differential signal according to a pair of sensors in these sensors.

In addition, the second-stage differential circuit includes a pair or a plurality of first subtractors (e.g. integrators in integrating circuits 324). Each of first subtractors generates a second-stage differential signal according to a pair of first-stage differential signals in these first-stage differential signals.

Further, the measuring circuit may be an ADC circuit as shown FIG. 3A, a combination of integrator 324 and an ADC circuit as shown in FIG. 3D, or a combination of a plurality of integrator 324, ADC circuits and a switching circuit 370 as shown in FIG. 3I. Moreover, the measuring circuit measures these second-stage differential signal at one or a plurality of time points to generate the sensing information. As shown in FIG. 3D or FIG. 3J, these second-stage differential signals are measured at a plurality of time points, or as shown in FIG. 3I, these second-stage differential signals are measured at a single time point.

In FIGS. 3D, 3I and 3J of the present invention, differential integrators 324 are used for simultaneous subtraction and measurement of signals, wherein the subtraction of signals can further include generating a digital value using an ADC circuit. The drawings and descriptions given above are merely examples of the present invention; the present invention is not limited to these. One with ordinary skill in the art can recognize that signal subtraction and measurement can be performed by different circuits, for example, first by a subtractor then an integrator, which will not be described further in details.

In said dual-differential circuit, each value of the sensing information is generated by one of these second-stage differential signals, and each of the second-stage differential signals is generated by a first differential signal and a second differential signal of a pair of first-stage differential signals, wherein the first differential signal is generated based on a signals of a first sensor and a second sensor of these sensors, and the second differential signal is generated based on a signals of the second sensor and a third sensor of these sensors. In other words, each value of the sensing information corresponds to signals of three sensors in these sensors.

In a second example of the present invention, the sensing information can be obtained by a differential circuit, which

includes: one or a plurality of subtractors and a measuring circuit, as shown in FIG. 3C, 3G or 3H. In these subtractors, each subtractor generates a differential signal according to signals of a pair of sensors. The measuring circuit measures these differential signals to generate a differential sensing information, wherein each value of the sensing information is the difference of a pair of values of the differential sensing information.

Further, the measuring circuit may measure these differential signals at one or a plurality of time points to generate the sensing information. As shown in FIG. 3C or FIG. 3H, these differential signals are measured at a plurality of time points, or as shown in FIG. 3G, these differential signals are measured at a single time point.

In FIG. 3C, 3G or 3H of the present invention, the subtractors and a portion of the measuring circuit can be implemented by integrator 324. The drawings and descriptions given above are merely examples of the present invention; the present invention is not limited to these. One with ordinary skill in the art can recognize that signal subtraction and measurement can be performed by different circuits, for example, first by a subtractor then an integrator, which will not be described further in details.

In addition, each value of the sensing information is generated by the difference of a first difference and a second difference of the differential signals, wherein the first difference is generated based on a signals of a first sensor and a second sensor of these sensors, and the second difference is generated based on a signals of the second sensor and a third sensor of these sensors. In other words, each value of the sensing information corresponds to signals of three sensors in these sensors.

In a third example of the present invention, the sensing information can be obtained by a measuring circuit, as shown in FIG. 3B, 3E or 3F. The measuring circuit measures signals of these sensors to generate an initial sensing information. The sensing information is generated according to the initial sensing information, wherein each value of the sensing information is generated from three values of the initial sensing information.

Further, the measuring circuit may measure these signals at one or a plurality of time points to generate the initial sensing information. As shown in FIG. 3B or FIG. 3F, these signals are measured at a plurality of time points, or as shown in FIG. 3E, these signals are measured at a single time point.

Each value of the sensing information is the difference or sum of the first difference and a second difference, wherein the first difference is the difference between two prior values of three values of the initial sensing information, and the second difference is the difference between two latter values of the three values of the initial sensing information. In other words, the three values of the initial sensing information are a first value, a second value and a third value. Each value of the sensing information is (second value–first value)–(third value–second value), (first value–second value)–(second value–third value), (second value–first value)+(second value–third value), or (first value–second value)+(third value–second value). Each value of the initial sensing information is generated according to signals of one of these sensors, that is, each value of the initial sensing information corresponds to signals of three sensors of these sensors.

In an example of the present invention, each touch related sensing information of the sensing information has two zero-crossings, and a position touched or approached by an external object is determined by each touch related sensing information. In another example of the present invention, the touch related sensing information is at the beginning or end portion

of the sensing information, an external object only approaches or touches the edges of the active region of the touch-detection device. In this case, there will not be two zero-crossings, and exception handling is required.

Moreover, said time points may include but not limited to via one or more clocks, or portions of one or more clocks.

Furthermore, the obtaining and generation of said sensing information can be implemented by controller **160**. Said dual-differential circuit, differential circuit and measuring circuit can also be implemented by the controller **160**.

In the present invention, sensors can consist of a plurality of conductive sheets and wires, such as a set of rhombic or square conductive sheets connected together by wires. Structurally, conductive sheets of first sensors **140A** and second sensors **140B** may be arranged in different or same planes. For example, an insulating or piezoresistive layer can be interposed between first and second sensing layers **120A** and **120B**, wherein the piezoresistive layer is made from anisotropic conductive gel. Moreover, for example, conductive sheets of first sensors **140A** and second sensors **140B** are substantially arranged in the same plane, with the wires of first sensors **140A** bridging over the wires of second sensors **140B**. In addition, pads can be disposed between the wires of first sensors **140A** and second sensors **140B**. These pads can be made of insulating or piezoresistive materials.

Thus, in an example of the present invention, each sensor is responsible for a sensing range. There are a plurality of sensors, including a plurality of first sensors and a plurality of second sensors. The sensing ranges of these first sensors are parallel to each other, while the sensing ranges of these second sensors are parallel to each other. The parallel sensing ranges of the first and second sensors intersect to form an intersecting matrix. For example, the first and second sensors are two lines of infrared receivers arranged horizontally and vertically for sensing horizontal scanning ranges and vertical scanning ranges, respectively. The horizontal and vertical scanning ranges form an intersecting matrix. The horizontal and vertical scanning ranges are implemented by several lines of intersecting capacitive or resistive sensors.

#### Conversion of Sensing Information

The signal values, differences and dual differences of the sensing information can be converted into one another. In a first conversion method provided by the present invention, continuous signal values are converted into continuous differences; each difference being the difference between a pair of adjacent or non-adjacent signal values.

In a second conversion method provided by the present invention, continuous signal values are converted into continuous dual differences; each dual difference being the sum or difference between two pairs of signal values.

In a third conversion method provided by the present invention, continuous differences are converted into continuous signal values; each difference is added to all the preceding or following differences to obtain a corresponding signal value, thereby constructing continuous signal values.

In a fourth conversion method provided by the present invention, continuous differences are converted into continuous dual differences; each dual difference is the sum or difference of a pair of adjacent or non-adjacent differences.

In a fifth conversion method provided by the present invention, continuous dual differences are converted into continuous differences; each dual difference is added to all the preceding or following dual differences to obtain a corresponding difference, thereby constructing continuous differences.

In a sixth conversion method provided by the present invention, continuous dual differences are converted into con-

tinuous signal values. In an example of the present invention, each dual difference is added to all the preceding dual differences to obtain a corresponding difference, thereby constructing continuous differences, and thereafter each difference subtracts all the following differences to generate a corresponding signal value, thereby constructing continuous signal values. In another example of the present invention, each dual difference subtracts all the preceding dual differences to obtain a corresponding difference, thereby constructing continuous differences, and thereafter each difference is added to all the following differences to generate a corresponding signal value, thereby constructing continuous signal values.

Adding all the preceding or following differences or dual differences to generate a corresponding signal value or difference is performed by forward or backward accumulation.

These conversion methods may include but not limited to the conversion of 1-D sensing information, one with ordinary skill in the art can appreciate that the above conversion methods can be applied to 2-D sensing information or 3-D (or even more dimensional) sensing information. In addition, one with ordinary skill in the art can appreciate that the above conversion methods can be performed by said controller **160** or host **170**.

Accordingly, in an example of the present invention, a first form of sensing information (e.g. 1-D or 2-D sensing information) detected is converted into sensing information for position analysis. In another example of the present invention, a first form of sensing information is converted into a second form of sensing information, and then the second form of sensing information is converted into sensing information for position analysis, for example, continuous dual difference is converted to continuous signal values.

#### One-Dimension Position Analysis

A first type of position analysis provided by the present invention involves analyzing the position of a zero-crossing based on a plurality of differences in sensing information as the corresponding position of an external object. One with ordinary skill in the art can recognize that position analysis may include but not limited to determination of the touch or proximity of an object, that is, determination of a corresponding position of an external object may include but not limited to the touch or proximity of the object.

In an example of the present invention, a pair of neighboring differences including a positive and a negative value is searched, that is, a pair of positive and negative values at both sides of a zero-crossing, and then the position of the zero-crossing in this pair of neighboring differences is then determined, for example, a slope is determined based on this pair of adjacent differences to infer the position of the zero-crossing. In addition, order of the positive and negative values can be used in conjunction for determining the position of the zero-crossing. Said pair of neighboring differences can be directly adjacent to each other, or not adjacent and with at least one zero value between them. In addition, a pair of neighboring differences with a predetermined order of arrangement can be searched for, for example, a pair of neighboring differences with a positive value appearing first and followed by a negative value is searched for.

In another example of the present invention, a threshold is used for determining the starting position of the search. From there, a pair of neighboring differences including a positive and a negative value is searched for, and then the position of a zero-crossing is determined based on the found pair of neighboring differences. One with ordinary skill in the art can appreciate that in the case that sensing information is represented by differences, when sensing information corresponding to the touch or proximity of an external object is above a

positive threshold or below a negative threshold, the searching using these threshold values may include but not limited to the determination of the touch or proximity of the external object. In other words, whenever sensing information is above a positive threshold or below a negative threshold, it can be determined that there is a zero-crossing in the sensing information that corresponds to a touch or proximity of an external object.

For example, a threshold generates binary values corresponding to positive differences. For example, a difference smaller than a threshold (e.g. positive threshold) is represented by 0 or false, and a difference larger than the threshold is represented by 1 or true, and the position of a 1 or true in adjacent differences 10 is regarded as the starting position for a backward search of a zero-crossing. Similarly, a difference larger than a threshold (e.g. negative threshold) is represented by 0 or false, and a difference smaller than the threshold is represented by 1 or true, and the position of a 1 or true in adjacent differences 01 is regarded as the starting position for a forward search of a zero-crossing.

For example, Table 1 and FIG. 4B are examples of using threshold for determining touch or proximity of an external object.

TABLE 1

Index	Signal Value	Difference	First Binary Difference (T1 = 4)	Second Binary Difference (T2 = -4)
1	0	0	0	0
2	0	0	0	0
3	0	3	0	3
4	3	7	1	0
5	10	-7	0	1
6	3	-3	0	0
7	0	0	0	0
8	0	0	0	0
9	0	2	0	0
10	2	5	1	0
11	7	0	0	0
12	7	-5	0	1
13	2	-2	0	0
14	0	0	0	0
15	0	0	0	0

This example includes signal values or difference of 15 sensors and determination results using a positive threshold T1 (e.g. 4) and a negative threshold T2 (e.g. -4). In the determination results using the positive threshold, the starting positions are the 4th and 10th differences, that is, the position of a 1 in adjacent differences 10. In the diagram with vertical-stripe bar, it is found that there are two instances of touch or proximity of external objects. Similarly, in the determination results using the negative threshold, the starting positions are the 5th and 12th differences, that is, the position of a 1 in adjacent differences 01. In the diagram with horizontal-stripe bar, it is found that there are two instances of touch or proximity of external objects. One with skill the art can appreciate that the number of starting position corresponds to the number of instances of touch or proximity of external objects. The present invention does not limit to only two instances of touch or proximity of external objects, but there can be more.

In another example of the present invention, an interval for a zero-crossing is determined using a first threshold and a second threshold, which may include but not limited to touch or proximity of an external object, and then the position of the zero-crossing is searched within this interval. For example, a first threshold produces binary values of positive differences, for example, a difference smaller than the first threshold is

represented by 0 or false, and a difference larger than the first threshold is represented by 1 or true, and the position of a 1 in adjacent differences 10 is regarded as the starting position. In addition, a second threshold produces binary values of negative differences, for example, a difference larger than the second threshold is represented by 0 or false, and a difference smaller than the second threshold is represented by 1 or true, and the position of a 1 in adjacent differences 01 is regarded as the end position. Moreover, the starting and end positions are paired to form intervals for searching zero-crossings. In an example of the present invention, a slope is used to determine the zero-crossing between a starting position (e.g. position of a 1 in 10) and an end position (e.g. position of a 1 in 01). One with ordinary skill in the art can appreciate that the starting and end positions are interchangeable. One with ordinary skill in the art can appreciate that touch related sensing information can be determined by regarding the location of 1 in 01 as the starting position and the location of 1 in 10 as the end position.

Take again the example shown in FIG. 4A and Table 1, after pairing, a first search interval is between the 4th and 5th differences, and a second search interval is between the 10th and 12th differences.

One with ordinary skill in the art can appreciate that positive and negative thresholdings can be performed simultaneously (or in parallel). Interval pairing can be carried out by pairing a determined starting position with an end position that determined immediately afterwards.

In an example of the present invention, thresholds can be generated by sensing information. For example, a threshold value can be determined by multiplying a maximum of the absolute values of all differences by a ratio (e.g. a ratio smaller than one, such as 0.9), or a positive threshold value can be determined by multiplying a maximum of all positive differences by a ratio, or a negative threshold value can be determined by multiplying a minimum of all negative differences by a ratio. In other words, a threshold value can be static or dynamic. Thus, when the absolute value of a threshold is relatively large, it is possible that external object is determined when using the positive thresholding but not in the negative thresholding, or vice versa. A larger threshold value is favorable for noise or ghost points filtering, while a smaller threshold value is favorable for avoiding miss of real touch or for determining approaching of external objects.

From the above, it is clear that, corresponding to the same touch or approaching of an object, regardless of a backward search from a starting position identified using a positive threshold value or a forward search from a starting position identified using a negative threshold value, the same zero-crossing will be searched. Thus, in an example of the present invention, search for a zero-crossing starts from starting positions identified using positive and negative threshold values, and the number of external touch or approaching is determined based on the number of zero-crossings found, and then the positions of the zero-crossings are determined. When the values at both sides of a zero-crossing that corresponds to an external touch or approaching are first positive and then negative, the search for zero-crossing is backward from the starting position when using positive thresholding, whereas the search for zero-crossing is forward from the starting position when using negative thresholding, and vice versa. In addition, an external touch or approaching may not always exhibit starting positions in both positive and negative thresholdings.

A second type of position analysis provided by the present invention involves analyzing the position of centroid (position of center of weight or weighted average position) based

on a plurality of signal values or dual differences in sensing information as the corresponding position of an external object.

In an example of the present invention, a threshold value is used to determine the centroid position of signal values or dual differences, as shown in FIGS. 4B and 4D. A threshold can generate binary values corresponding to signal values or dual differences. For example, a signal value or dual difference smaller than a threshold is represented by 0 or false, and a signal value or dual difference larger than the threshold is represented by 1 or true. In this example, a signal value or dual difference represented by 1 or true is used in determining centroid position. One with ordinary skill in the art can appreciate other ways for determining a centroid position of signal values or dual differences using a threshold. For example, a signal value or dual difference represented by 1 or true, as well as a plurality of signal values or dual differences at either side thereof, are used in determining centroid position. As another example, in a continuous series of adjacent signal value or dual difference represented by 1 or true, a number (i) of and a number (j) of signal values or dual differences before and after a signal value or dual difference that is at the center of the series are taken to determine the centroid position.

In another example of the present invention, continuous signal values or dual differences are converted into continuous differences to identify the center signal value or dual difference that corresponds to a zero-crossing, and i and j signal values or dual differences before and after the center signal value or dual difference are used for determining the centroid position.

In another example of the present invention, a zero-crossing is determined by continuous differences, and the continuous differences are converted into continuous signal values or dual differences, and then the center signal value or dual difference that corresponds to the zero-crossing is identified, thereafter, i and j signal values or dual differences before and after the center signal value or dual difference are used for determining the centroid position.

Assuming that using i and j signal values respectively before and after the nth signal value as a centroid calculation range, the centroid position can be determined based on each signal value  $C_k$  and its position in the centroid calculation range as follows:

$$C_{centroid} = \frac{\sum_{k=n-i}^{n+j} X_k C_k}{\sum_{k=n-i}^{n+j} C_k}$$

wherein  $X_k$  can be a 1-D coordinate (e.g. X or Y coordinate) or 2-D coordinates (e.g. (X, Y)).

Assuming the difference between the k-1th signal value and the kth signal value is  $D_k$ , and the kth dual difference is  $DD_k = D_{k-1} - D_k = (C_k - C_{k-1}) - (C_{k+1} - C_k) = 2C_k - C_{k-1} + C_{k+1}$ , and assuming using i and j signal values respectively before and after the nth dual difference  $DD_n$  as a centroid calculation range, the centroid position can be determined based on each dual difference  $DD_k$  in the centroid calculation range as follows:

$$DD_{centroid} = \frac{\sum_{k=n-i}^{n+j} X_k DD_k}{\sum_{k=n-i}^{n+j} DD_k}$$

wherein  $X_k$  can be a 1-D coordinate (e.g. X or Y coordinate) or 2-D coordinates (e.g. (X, Y)). One with ordinary skill in the art can similarly appreciate the calculation for centroid position when the kth dual difference is  $DD_k = (C_k - C_{k-2}) - (C_{k+2} - C_k) = 2C_k - C_{k-2} + C_{k+2}$ . This will not be described further.

In another example of the present invention, signal values or dual differences used for determining centroid position is obtained by first subtracting a base value. For example, this base value can be the average of all signal values or dual differences, the average of a plurality of signal values or dual differences at either sides of the signal values or dual differences used for centroid position determination, or the average of a plurality of signal values or dual differences not used for centroid position determination that are adjacent to either sides of the signal values or dual differences used for centroid position determination. One with ordinary skill in the art can recognize other ways of determining the base value. For example, the base value can be determined based on a first ratio of at least one signal value or dual difference at one side and a second ratio of at least one signal value or dual difference at the other side.

Taken the average of the ith signal value  $C_{n-i}$ , and the jth signal value  $C_{n+j}$ , respectively before and after the nth signal value as base value

$$C_{base(i,j)} = \frac{C_{n-i} + C_{n+j}}{2}$$

and using i and j signal values respectively before and after the nth signal value as a centroid calculation range, the centroid position can be determined based on each signal value  $C_k$  minus the base value  $C_{base(i,j)}$  in the centroid calculation range as follows:

$$C_k - C_{base(i,j)} = \frac{2C_k - C_{n-i} - C_{n+j}}{2} = \frac{(C_k - C_{n-i})}{2} + \frac{(C_k - C_{n+j})}{2}$$

$C_{centroid} =$

$$\frac{\sum_{k=n-i}^{n-i \leq k \leq n+j} X_k \left( \frac{2C_k - C_{n-i} - C_{n+j}}{2} \right)}{\sum_{k=n-i}^{n-i \leq k \leq n+j} \frac{2C_k - C_{n-i} - C_{n+j}}{2}} = \frac{\sum_{k=n-i}^{n-i \leq k \leq n+j} X_k (2C_k - C_{n-i} - C_{n+j})}{\sum_{k=n-i}^{n-i \leq k \leq n+j} (2C_k - C_{n-i} - C_{n+j})}$$

wherein  $X_k$  can be a 1-D coordinate (e.g. X or Y coordinate) or 2-D coordinates (e.g. (X, Y)).

A third type of position analysis provided by the present invention involves analyzing the position of centroid (position of center of weight or weighted average position) based on a plurality of differences in sensing information as the corresponding position of an external object.

Assuming the difference between the k-1th signal value  $C_{k-1}$  and the kth signal value  $C_k$  is  $D_k$ .

$$\begin{aligned}
(C_k - C_{n-i}) &= D_{n-(i-1)} + D_{n-(i-2)} + \dots + D_k \\
(C_k - C_{n+j}) &= -(D_{k+1} + D_{k+2} + \dots + D_{n+j}) \\
C_k - C_{base(i,j)} &= \frac{2C_k - C_{n-i} - C_{n+j}}{2} = \\
&= \frac{(D_{n-(i-1)} + D_{n-(i-2)} + \dots + D_k) - (D_{k+1} + D_{k+2} + \dots + D_{n+j})}{2} \\
C_k - C_{base(i,j)} &= \frac{\sum_{s=n-(i-1)}^k D_s - \sum_{s=k+1}^{n+j} D_s}{2} \\
C_{centroid} &= \frac{\sum_{s=n-i}^{n-i \leq k \leq n+j} X_s \left( \frac{\sum_{s=n-(i-1)}^k D_s - \sum_{s=k+1}^{n+j} D_s}{2} \right)}{\sum_{s=n-i}^{n-i \leq k \leq n+j} \frac{\sum_{s=n-(i-1)}^k D_s - \sum_{s=k+1}^{n+j} D_s}{2}} = \\
&= \frac{\sum_{s=n-i}^{n-i \leq k \leq n+j} X_k \left( \frac{\sum_{s=n-(i-1)}^k D_s - \sum_{s=k+1}^{n+j} D_s}{2} \right)}{\sum_{s=n-i}^{n-i \leq k \leq n+j} \left( \frac{\sum_{s=n-(i-1)}^k D_s - \sum_{s=k+1}^{n+j} D_s}{2} \right)}
\end{aligned}$$

Accordingly, the centroid position  $C_{centroid}$  can be calculated based on the differences between the signal values, wherein the differences in the centroid calculation range are  $D_{n-(i-1)}, D_{n-(i-2)}, \dots, D_k, D_{k+1}, \dots, D_{n+j}, D_{n+(j+1)}$ . In other words, the centroid position  $C_{centroid}$  can be calculated based on the differences in the centroid calculation range.

As an example, assuming 1 signal value before and after the  $n$ th signal value are taken for determining the centroid position, differences in the centroid calculation range can be used to calculate it. This is proven as follows:

$$\begin{aligned}
D_{n-1} &= C_{n-1} - C_{n-2} \\
D_n &= C_n - C_{n-1} \\
D_{n+1} &= C_{n+1} - C_n \\
D_{n+2} &= C_{n+2} - C_{n+1} \\
C_{base(2,2)} &= \frac{C_{n-2} + C_{n+2}}{2} \\
C_{n-1} - C_{base(2,2)} &= \frac{2C_{n-1} - C_{n-2} - C_{n+2}}{2} = \frac{D_{n-1} - D_n - D_{n+1} - D_{n+2}}{2} \\
C_n - C_{base(2,2)} &= \frac{2C_n - C_{n-2} - C_{n+2}}{2} = \frac{D_{n-1} + D_n - D_{n+1} - D_{n+2}}{2} \\
C_{n+1} - C_{base(2,2)} &= \frac{2C_{n+1} - C_{n-2} - C_{n+2}}{2} = \frac{D_{n-1} + D_n + D_{n+1} - D_{n+2}}{2} \\
C_{centroid} &= \frac{X_{n-1}(C_{n-1} - C_{base(2,2)}) + X_n(C_n - C_{base(2,2)}) + X_{n+1}(C_{n+1} - C_{base(2,2)})}{(C_{n-1} - C_{base(2,2)}) + (C_n - C_{base(2,2)}) + (C_{n+1} - C_{base(2,2)})} \\
C_{centroid} &= \\
&= \frac{X_{n-1}(D_{n-1} - D_n - D_{n+1} - D_{n+2}) + X_n(D_{n-1} + D_n - D_{n+1} - D_{n+2}) + X_{n+1}(D_{n-1} + D_n + D_{n+1} - D_{n+2})}{(D_{n-1} - D_n - D_{n+1} - D_{n+2}) + (D_{n-1} + D_n - D_{n+1} - D_{n+2}) + (D_{n-1} + D_n + D_{n+1} - D_{n+2})}
\end{aligned}$$

One with ordinary skill in the art can recognize that taking  $i$  and  $j$  signal values, differences or dual differences respec-

tively before and after the  $n$ th signal value as the centroid calculation range can be applied to determine the signal value, difference or dual difference on the centroid position.

From the above description, it can be seen that the present invention performs position detection by analyzing sensing information that may not only include originally obtained signal values, differences, or dual differences, but also signal values, differences, or dual differences converted from originally obtained sensing information. By analyzing 1-D or 2-D sensing information on two difference axes (e.g. X and Y axes) that corresponds to the same object, that is, by performing 1-D or 2-D position analysis on two different axes, the positions (or coordinates) of the object on these two axes can be obtained, thereby a 2-D position (or 2-D coordinates) can be constructed.

One with ordinary skill in the art can appreciate that operations of the above 1-D position analysis can be performed by said controller **160** or host **170**.

#### Two-Dimension Position Analysis

2-D sensing information can be comprised of a plurality of 1-D sensing information, wherein each 1-D sensing information includes sensing information that corresponds to a plurality of first 1-D positions, and each 1-D sensing information corresponds to a second 1-D position. Thus, 2-D position analysis can at least include 1-D position analysis on a plurality of 1-D touch sensitive information, that is, 2-D position analysis can at least include a plurality of 1-D position analysis.

In addition, in a first example of the present invention, a first 1-D centroid position of any external object on each first dimensional sensing information is a 2-D position (e.g. 2-D coordinates (first 1-D centroid position, second 1-D position of the first dimensional sensing information)), and can be used to calculate a 2-D centroid position of the object (or center of geometry), wherein the weight of each 1-D centroid position can be a signal value or dual difference of the external object on the corresponding first dimensional sensing information (e.g. one or average or interpolation of two signal values or dual differences closest to the 1-D centroid position on the first dimensional sensing information), or sum of signal values or dual differences of the external object on the corresponding first dimensional sensing information.

Thus, 2-D position analysis can perform 1-D position analysis on each first dimensional sensing information, and analyze a 2-D centroid position of each external object based on at least one 2-D position that corresponds to each external object.

In addition, in a second example of the present invention, 2-D position analysis may include performing 1-D position analysis on a plurality of 1-D sensing information on a first axis (or a first dimension), respectively, and based on at least one 1-D position corresponding to each external object on the first axis, analyzing a first 1-D centroid position of each external object on the first axis. Similarly, 2-D position analysis may further include performing 1-D position analysis on a plurality of 1-D sensing information on a second axis (or a second dimension), respectively, and based on at least one 1-D position corresponding to each external object on the second axis, analyzing a second 1-D centroid position of each external object on the second axis. By pairing the first 1-D centroid position on the first axis with the second 1-D centroid position on the second axis for each external object, a 2-D position for each external object can be analyzed.

In other words, 2-D position analysis may include performing 1-D position analysis on 2-D sensing information on two different axes (e.g. 2-D sensing information on the first axis

and 2-D sensing information on the second axis) to obtain a 2-D position for each external object.

In addition, in a third example of the present invention, 2-D position analysis may include analyzing 1-D centroid position corresponding to each external object from a plurality of 1-D sensing information on a first axis, and based on a 2-D position corresponding to each 1-D sensing information, determining a 2-D position of each 1-D centroid position that corresponds to each external object on the first axis. 2-D position analysis may further include analyzing 1-D centroid position corresponding to each external object from a plurality of 1-D sensing information on a second axis, and based on a 2-D position corresponding to each 1-D sensing information, determining a 2-D position of each 1-D centroid position that corresponds to each external object on the second axis. 2-D position analysis may further include analyzing a 2-D centroid position based on the 2-D positions of all 1-D centroid positions on the first and second axes that correspond to each external object.

One with ordinary skill in the art can appreciate that 2-D sensing information can determine the position of each external object by image processing, for example, using watershed or other image processing techniques. As another example, watershed algorithm can be used to analyze the position of each watershed, and then the centroid position is calculated using sensing information near each watershed position to obtain a more accurate position.

In a fourth example of the present invention, a plurality of 1-D sensing information originally obtained can be represented by signal values or dual differences, which construct an image (or matrix) formed from 2-D sensing information. Watershed algorithm or other image processing techniques can be used for position analysis. Alternatively, a "connected component" algorithm can be used, which analyzes connected portions in an image to determine an image of each external object, and further determines the position or the type of the object, such as a finger, a palm or a pen.

In a fifth example of the present invention, a plurality of 1-D sensing information originally obtained can be represented by differences, which are then converted into signal values or dual differences, which in turn construct an image (or matrix) formed from 2-D sensing information. Watershed algorithm or other image processing techniques can be used for position analysis.

In a sixth example of the present invention, a plurality of 1-D sensing information originally obtained can be represented by differences. By performing position analysis on each 1-D sensing information, the position of each zero-crossing, as well as the signal value or dual difference on the position of each zero-crossing can be determined, thereby constructing an image (or matrix) formed from 2-D sensing information. Watershed algorithm or other image processing techniques can be used for position analysis.

The dual difference of a zero-crossing point can be generated by two directly adjacent differences, for example, a zero-crossing is between the  $k-1$ th difference and the  $k$ th difference, and the dual difference at this zero-crossing point is  $DD_k = D_{k-1} - D_k$ . The signal value of a zero-crossing point can be generated after converting all differences representing the 1-D sensing information into signal values, or generated based on a plurality of differences closest to the zero-crossing. For example, zero-crossing is closest to the  $n$ th signal value, and the average of  $i$ th signal value  $C_{n-i}$  and the  $j$ th signal value  $C_{n+j}$ , before and after the  $n$ th signal value is taken as the base value

$$C_{base(i,j)} \left( C_{base(i,j)} = \frac{C_{n-i} + C_{n+j}}{2} \right),$$

and

$$C_n - C_{base(i,j)} = \frac{2C_n - C_{n-i} - C_{n+j}}{2}$$

is taken as the signal value, then

$$C_n - C_{base(i,j)} = \frac{2C_n - C_{n-i} - C_{n+j}}{2} = \frac{(D_{n-(j-i)} + D_{n-(i-2)} + \dots + D_n) - (D_{n+1} + D_{n+2} + \dots + D_{n+j})}{2}.$$

In other words, between the  $n-(i-1)$ th difference to the  $(n+j)$ th difference, the signal value at zero-crossing can be determined.

In a seventh example of the present invention, a plurality of 1-D sensing information originally obtained can be represented by signal values and dual differences and are then converted to differences. By performing analysis on each 1-D sensing information, the position of each zero-crossing is determined. In conjunction with the signal value or dual difference on each zero-crossing position, an image (or matrix) formed by 2-D sensing information can be constructed. Watershed algorithm or other image processing techniques can be used for position analysis.

In an eighth example of the present invention, when or in the process of obtaining 2-D sensing information on the first axis, 1-D sensing information on the second axis is also obtained. After performing position analysis on the position of the 2-D sensing information on the first axis, the 1-D position or 2-D position of each external object on the first axis can be obtained. In addition, after performing position analysis on the position of the 2-D sensing information on the second axis, the 1-D position of each external object on the second axis can be obtained. The 1-D position on the second axis can be paired up with the 1-D position on the first axis to form a 2-D position, or can be used to replace or correct the position on the second axis in the 2-D position on the first axis.

One with ordinary skill in the art can appreciate that the operations of the above 2-D position analysis can be performed by said controller **160** or host **170**. In addition, in an example of the present invention, the 1-D distance or 2-D distance between each 1-D centroid position corresponding to the same touch or approach and at least one other 1-D centroid position corresponding to the same touch or approach is within a threshold. In another example of the present invention, the weight of each 1-D centroid position corresponding to the same touch or approach is greater than a threshold.

In the following description, a touch related sensing information can be a touch related sensing information or one of multiple touch related sensing information in a sensing information. Operations related to touch related sensing information can be applied not only to specific touch related sensing information but also to all touch related sensing information of the present invention.

In addition, for convenient description, in numerous diagrams and descriptions of the present invention, explanations

are given in terms of positive values. One with ordinary skill in the art can appreciate that same principles are applicable to sensing information after having swapped its positive and negative values with each other.

The 2-D sensing information proposed by the present invention can be partial sensing information with inner lower values within outer high values, as shown by a basin **610** in FIGS. **6A** and **6B**. In an example of the present invention that includes a plurality of dual differences as 2-D sensing information, when an external object touches a large area, in the corresponding touch related sensing information, locations closer to the center of the area will exhibit depressions (smaller values) relative to surrounding higher locations (larger values). In another example of the present invention that includes a plurality of differences as 2-D sensing information in which all negative values are converted to positive values, when the area touched by an external object is larger than a certain degree, in the corresponding touch related sensing information, locations closer to the middle of the area will exhibit depressions (smaller values) relative to surrounding higher locations (larger values). If they are viewed as topographic relief, partial sensing information with lower inner values within higher external values may be regarded as a valley or basin area in the 2-D sensing information, including higher and lower places surrounding a valley or basin. For example, it can be a valley surrounded by one or more mountains, e.g. a basin surrounded by mountains or canyon, or a mountain or a plateau with a depressed top. Sensing information with inner lower values within outer high values can be one or more openings, e.g. a canyon open at both ends. In 2-D sensing information that includes a plurality of dual differences, touch related sensing information may also include a trench surrounding a valley. In contrast, partial sensing information with inner higher values within outer low values may be a hill or a plateau with one or more peaks. Each peak is partial sensing information with inner higher values within outer low values, wherein the peak are higher locations (larger values) relative to other surrounding lower locations (small values), as illustrated by basins **610** shown in FIGS. **6A** and **6B**. In an example of the present invention, a hill with several peaks corresponds to neighboring partial sensing information inner lower values within outer high values. In 2-D sensing information that includes a plurality of signal values, touch related sensing information that contains partial sensing information with inner higher values within outer low values can be a hill (smaller range) or a plateau (larger range). Similarly, 2-D sensing information that includes a plurality of dual differences or differences in which all negative values have been converted into positive values can also include a hill or a plateau. In an example of the present invention, partial sensing information with inner lower values within outer high values and partial sensing information with inner higher values within outer low values are touch related sensing information. In another example of the present invention, a plateau is regarded as a larger hill, and a basin is regarded as a valley without or fewer openings. In yet another example of the present invention, touch related sensing information that is not a valley or a basin is a hill, or that is not a hill is a valley or a basin.

In the following descriptions, a basin is used to represent partial sensing information with inner lower values within outer high values, and a hill is used to represent partial sensing information with inner higher values within outer low values for the sake of convenience, and the present invention is not limited to these aspects. One with ordinary skill in the art can appreciate other aspects of partial sensing information with

inner lower values within outer high values and partial sensing information with inner higher values within outer low values.

In a first embodiment of the present invention, a method for analyzing 2-D sensing information according to the best mode of the present invention is provided as shown in FIG. **5**. First, in step **510**, a first 2-D sensing information is obtained. Next, in step **520**, the first 2-D sensing information is analyzed to determine each touch related sensing information with inner lower values within outer high values. Thereafter, in step **530**, the first 2-D sensing information is analyzed to determine each touch related sensing information with inner higher values within outer low values. As described earlier, the analysis can be an image segmentation method, such as the watershed algorithm, a connected component labeling or other ways of determining touch related sensing information, for example, other methods for analyzing 2-D sensing information capable of distinguishing hills, valleys or basins. When the first 2-D sensing information is constituted by a plurality dual differences, the periphery of the valley, basin or hill may be surrounded by a trench, as shown in FIG. **6A**. In an example of the present invention, this trench can be removed by nulling all positive values or all negative values of the 2-D sensing information. In another example of the present invention, a second 2-D sensing information can first be obtained, and then all positive values of the second 2-D sensing information are converted to negative values, or all negative values converted to positive values, to provide the first 2-D sensing information. In the case that the second 2-D sensing information includes a plurality of differences in which all negative values are converted to positive values, touch related sensing information may include a hill with one or two peaks, or a valley or a basin, as shown in FIG. **6B**. For a hill with just one peak, the peak corresponds to the touch location. In contrast, for a hill with two peaks, the chasm corresponds to the touch location. In FIGS. **6A** and **6B**, there is a plurality of lateral line segments; each line segment being a 1-D sensing information. In each of the 1-D sensing information, there might be slight trembling at places that are non-touch locations. As described earlier, if these trembles are within a zero-value range, they are regarded as zero. Differential touch related sensing information or Dual differential touch related sensing information is composed by an alternating combination of at least one positive and negative value, which includes one or more zero-value combinations. Each zero-value combination includes at least one zero value between a pair of positive and negative values. In FIGS. **6A** and **6B**, differential touch related sensing information includes basins **610** and hills **620**. Basin **610** refers to a large-area touch, e.g. a palm touch. Hill **620** refers to a small-area touch, e.g. a finger or pen touch. In FIG. **6B**, hill **620** can be a one-peak hill **621** or two-peak hill **622**, wherein one-peak hill **621** has signal intensities concentrated in the center and can be use for recognizing a pen touch. Said basin **610** is only one example of the touch related sensing information with inner lower values within outer high values, and the present invention is not limited to this. One with ordinary skill in the art can appreciate other aspects of touch related sensing information with inner lower values within outer high values. In an example of the present invention, the watershed algorithm can be used determine each independent topography by using zero value and values less than zero as relative lower locations of a flow path, and thus forming one or more drainage areas; topographies isolated by the drainage areas including said basins **610** and hills **620**. One with ordinary skill in the art can appreciate that basin **610** can also include a lake surrounded by mountains. In another example of the present invention,



the connected component labeling can be used determine each independent topography, in which a threshold value is used to binarize 2-D sensing information, neighboring values larger than the threshold value are grouped to the same connecting object; each connecting object including said basins **610** and hills **620**. The analysis of said basins **610** and hills **620** is not limited to the watershed algorithm and connected component labeling, but can also be other image segmentation methods.

In addition, analyzed touch related sensing information can be provided using geometric information to represent geometric figures, such as circle, oval, rectangle, polygon etc. For example, a center of circle and radius can be used to represent a circle, two foci and the sum of distances of each point on an oval from the foci to represent an oval, two diagonal locations to represent a square or rectangle, or a plurality of locations to represent a polygon. Furthermore, locations of the analyzed touch related sensing information can be generated by calculation of centroid or a geometric center. Moreover, said partial touch related sensing information can be further converted into inner higher values within outer low values represented by signal values, e.g. a basin or a two-peak hill is converted into a hill represented by signal values. In other words, by conversion of partial touch related sensing information, the present invention can generate sensing information that includes a plurality of quasi signal values. For example, differential or dual-differential touch related sensing information representing a valley or basin can be converted into signal values, such as into signal values with inner higher values within outer low values. Differential or dual-differential touch related sensing information representing a two-peak or multi-peak valley can also be converted into signal values, such as into signal values with inner higher values within outer low values. In addition, the present invention further includes conversions between signal values, differences, and dual differences of touch related sensing information.

In an example of the present invention, steps **510** to **530** can be performed by controller **160** or host **170**. The first 2-D sensing information can be generated by a plurality of sensors of the sensing device, or converted from second 2-D sensing information generated by the signals of a plurality of sensors of the sensing device. Controller **160** provides 1-D sensing information each time it senses with the sensors. A plurality of 1-D sensing information constitute the first or second 2-D sensing information, wherein the first or second 2-D sensing information can be generated by controller **160** or host **170**. Further, conversion of valleys, basins or multi-peak hills into signal values or one-peak hill can also be performed by controller **160** or host **170**. Other details of the present embodiment have been disclosed in descriptions above and will not be repeated. In a second embodiment of the present invention, a method of analyzing 2-D dual-differential sensing information is provided as shown in FIG. 7A. First, in step **710**, a 2-D dual-differential sensing information is obtained, including a plurality of dual differences. Then, in step **720**, the 2-D dual-differential sensing information is analyzed to determine each touch related sensing information with inner lower values within outer high values in the 2-D dual-differential sensing information, such as a valley or a basin. In step **730**, the 2-D dual-differential sensing information is analyzed to determine each touch related sensing information with inner higher values within outer low values in the 2-D dual-differential sensing information, such as a hill.

In addition, analyzed touch related sensing information can be provided using geometric information to represent geometric figures, such as circle, oval, rectangle, polygon etc.

For example, a center of circle and radius can be used to represent a circle, two foci and the sum of distances of each point on an oval from the foci to represent an oval, two diagonal locations to represent a square or rectangle, or a plurality of locations to represent a polygon.

Furthermore, locations of the analyzed touch related sensing information, such as the locations of hills and basins, can be generated by calculation of centroid or a geometric center. Moreover, as described earlier, said partial touch related sensing information can be further converted into a hill represented by signal values. In other words, by conversion of partial touch related sensing information, the present invention can generate sensing information consisting of a plurality of quasi signal values. For example, differential or dual-differential touch related sensing information representing a valley or basin can be converted into signal values, such as into signal values with inner higher values within outer low values. Differential or dual-differential touch related sensing information representing a two-peak or multi-peak valley can also be converted into signal values, such as into signal values with inner higher values within outer low values. Accordingly, 2-D dual-differential sensing information after conversion of each valley or basin becomes sensing information that includes a plurality of quasi signal values, which is applicable to the method and device for determining touches by analyzing 2-D signal values. In addition, the present invention further includes conversions between signal values, differences, and dual differences of touch related sensing information.

Dual-differential sensing information can undergo a conversion process selected from the following: converting all negative values into zero values, converting all negative values into positive values, converting all positive values into zero values, and converting all positive values into negative values.

As described above, 2-D dual-differential sensing information can consist of a plurality of 1-D dual-differential sensing information. Each dual difference of each 1-D dual-differential sensing information is generated according to signals of three sensors in a plurality of sensors, wherein each dual difference is the difference or sum of a first difference and a second difference, the first difference being the signal difference between the prior two sensors, and the second difference being the signal difference between the latter two sensors.

2-D dual-differential sensing information can be converted from other 2-D sensing information, as shown in FIG. 7B. First, in step **711**, a plurality of 1-D sensing information is obtained, wherein each of the 1-D sensing information is generated based on signals of a plurality of sensors. Then, in step **712**, these 1-D sensing information are converted into 2-D dual-differential sensing information, wherein each value of the 2-D dual-differential sensing information is generated based on at least two values of these 1-D sensing information.

For example, each of 1-D sensing information includes a plurality of signal values, and each signal value is generated based on a signal of one of these sensors, and each dual difference is generated based on three signal values. As another example, each of 1-D sensing information includes a plurality of differences, and each difference is generated based on the difference of signals of a pair of these sensors, and each dual difference is generated based on a pair of differences.

In an example of the present invention, steps **710** to **730** can be performed by controller **160** or host **170**. The 2-D dual-differential sensing information can be generated by the signals of a plurality of sensors of the sensing device, or converted from a plurality of 1-D sensing information generated

by the signals of a plurality of sensors of the sensing device. Controller **160** provides 1-D sensing information each time it senses with the sensors. The 2-D dual-differential sensing information is constituted by or converted from a plurality of 1-D sensing information, wherein the 2-D dual-differential sensing information can be generated by controller **160** or host **170**. For example, one of controller **160** and host **170** converts these 1-D sensing information into 2-D dual-differential sensing information, where each of the 2-D dual-differential sensing information is generated based on at least two values of these 1-D sensing information. Other details of the present embodiment have been disclosed in descriptions above and will not be repeated.

In a third embodiment of the present invention, a method of analyzing 2-D differential sensing information is provided as shown in FIG. **8A**. First, in step **810**, a 2-D differential sensing information is obtained, including a plurality of differences. Then, in step **820**, all negative values of the 2-D differential sensing information are converted into positive values to generate a 2-D sensing information. Next, in steps **830** and **840**, the 2-D differential sensing information is analyzed to determine each touch related sensing information with inner lower values within outer high values, such as a valley or a basin, or touch related sensing information with inner higher values within outer low values, such as a hill.

In addition, analyzed touch related sensing information can be provided using geometric information to represent geometric figures, such as circle, oval, rectangle, polygon etc. For example, a center of circle and radius can be used to represent a circle, two foci and the sum of distances of each point on an oval from the foci to represent an oval, two diagonal locations to represent a square or rectangle, or a plurality of locations to represent a polygon.

Furthermore, locations of the analyzed touch related sensing information, such as the locations of hills and basins, can be generated by calculation of centroid or a geometric center. Moreover, as described earlier, said partial touch related sensing information can be further converted into a hill represented by signal values, for example, valleys, basins or two-peak hills are converted into inner higher values within outer low values represented by signal values. Accordingly, 2-D differential sensing information after conversion of each valley or basin becomes sensing information that includes a plurality of quasi signal values, which is applicable to the method and device for determining touches by analyzing 2-D signal values. In addition, the present invention further includes conversions between signal values, differences, and dual differences of touch related sensing information.

As mentioned before, 2-D differential sensing information can consist of a plurality of 1-D differential sensing information. Each difference of each 1-D differential sensing information is generated based on the difference of signals of a pair of sensors in a plurality of sensors, or as shown in FIG. **8B**, it is converted from sensing information that includes a plurality of signal values or dual differences. First in step **811**, a plurality of 1-D sensing information is obtained, wherein each of the 1-D sensing information is generated based on signals of a plurality of sensors. Then, in step **812**, these 1-D sensing information are converted into 2-D differential sensing information. In an example of the present invention, each value of the 2-D differential sensing information is generated based on a pair of values of these 1-D sensing information. In another example of the present invention, each of 1-D sensing information includes a plurality of dual differences, and each dual difference is generated based on the signals of three sensors in these sensors. In yet another example of the present invention, each 1-D sensing information corresponds to a

difference, and each difference is an accumulation of a corresponding dual difference with all dual differences preceding the corresponding dual difference in the 1-D sensing information, wherein the accumulation can be generated by increment or decrement. In an example of the present invention, steps **810** to **840** can be performed by controller **160** or host **170**. The 2-D differential sensing information can be generated by the signals of a plurality of sensors of the sensing device, or converted from a plurality of 1-D sensing information generated by the signals of a plurality of sensors of the sensing device. Controller **160** provides 1-D sensing information each time it senses with the sensors. The 2-D differential sensing information is constituted by or converted from a plurality of 1-D sensing information, wherein the 2-D differential sensing information can be generated by controller **160** or host **170**. For example, one of controller **160** and host **170** converts these 1-D sensing information into 2-D differential sensing information. Other details of the present embodiment have been disclosed in descriptions above and will not be repeated.

In a fourth embodiment of the present invention, a method of analyzing 2-D sensing information is provided as shown in FIG. **9**. First, in step **910**, a first 2-D sensing information is obtained, including a plurality of first 1-D sensing information. Then, in step **920**, at least one accumulation conversion is performed on each of the first 1-D sensing information to form a second 2-D sensing information, wherein the accumulation conversion converts each value in the 1-D sensing information into an accumulation of that value with all the values preceding or following that value, wherein the accumulation can be generated by increment or decrement. Next, in step **930**, image segmentation is performed on the 2-D sensing information to determine each touch related sensing information in the 2-D sensing information. In an example of the present invention, the touch related sensing information can be touch related sensing information with inner higher values within outer low values, such as a valley or a basin, or touch related sensing information with inner lower values within outer high values, such as a hill.

Said first 2-D sensing information may include a plurality of differences or dual differences, and the second 2-D sensing information can include a plurality of differences or signal values. In other words, 2-D differential sensing information with a plurality of differences can be converted into 2-D sensing information with a plurality of signal values, or 2-D dual-differential sensing information with a plurality of dual differences can be converted into 2-D differential sensing information with a plurality of differences or 2-D sensing information with a plurality of signal values. As described before, accumulation conversion converts each value in the 1-D sensing information into an accumulation of that value with all the values preceding or following that value. For example, 2-D differential sensing information with a plurality of differences can be converted into 2-D sensing information with a plurality of signal values, or 2-D dual-differential sensing information with a plurality of dual differences can be converted into 2-D differential sensing information with a plurality of differences. In an example of the present invention, each value of each first 1-D sensing information is converted into an accumulation of the value with all the values following it in a first accumulation conversion to generate a second 1-D sensing information; and each value of each second 1-D sensing information is converted into an accumulation of the value with all the values preceding it in a second accumulation conversion to generate a third 1-D sensing information, wherein the second 2-D sensing information includes these third 1-D sensing information. Alternatively,

each value of each first 1-D sensing information is converted into an accumulation of the value with all the values preceding it in a first accumulation conversion to generate a second 1-D sensing information; and each value of each second 1-D sensing information is converted into an accumulation of the value with all the values following it in a second accumulation conversion to generate a third 1-D sensing information, wherein the second 2-D sensing information includes these third 1-D sensing information.

In another example of the present invention, the second 2-D sensing information includes a plurality of fourth 1-D sensing information, and each of fourth 1-D sensing information is generated by converting all negative values of one of these third 1-D sensing information into positive values.

In an example of the present invention, steps 910 to 930 can be performed by controller 160 or host 170. Other details of the present embodiment have been disclosed in descriptions above and will not be repeated.

The above embodiments are only used to illustrate the principles of the present invention, and they should not be construed as to limit the present invention in any way. The above embodiments can be modified by those with ordinary skill in the art without departing from the scope of the present invention as defined in the following appended claims.

What is claimed is:

1. A method for analyzing 2-D image, comprising:

analyzing a first 2-D image generated during scanning a touch panel once to determine each touch related sensing information with inner lower values within outer high values caused by one touch or approach of external conductive object in the first 2-D image, wherein the first 2-D image consists of a plurality of 1-D sensing informations on a plurality of parallel axes so as to represent signal distribution on a 2-D plane.

2. The method of claim 1, further comprising:

converting each touch related sensing information with inner lower values within outer high values into touch related sensing information with inner higher values within outer low values.

3. The method of claim 1, further comprising:

obtaining a second 2-D sensing information;

performing a conversion on positive or negative values of the second 2-D sensing information to generate the first 2-D sensing information, the conversion selected from one of the group consisting of: converting negative to positive values, converting positive to negative values, converting positive to zero values, and converting negative to zero values; and  
converting each touch related sensing information with inner lower values within outer high values into touch related sensing information with inner higher values within outer low values based on a corresponding portion in the second 2-D image.

4. The method of claim 1, further comprising:

obtaining a second 2-D sensing information;

performing a conversion on positive or negative values of the second 2-D sensing information to generate the first 2-D sensing information, the conversion selected from one of the group consisting of: converting negative to positive values, converting positive to negative values, converting positive to zero values, and converting negative to zero values; and

converting each touch related sensing information with a plurality of peaks into touch related sensing information with inner higher values within outer low values based on a corresponding portion in the second 2-D image.

5. The method of claim 1, wherein the analyzing further includes:

analyzing the first 2-D image to determine each touch related sensing information with inner higher values within outer low values in the first 2-D image.

6. The method of claim 5, further comprising:

analyzing the contour of each touch related sensing information; and

outputting geometric information based on each contour, wherein representation of the geometric information is selected from one or a combination of the following representations: circle, oval, rectangle and polygon.

7. The method of claim 5, further comprising:

calculating a centroid location or a geometric center of each touch related sensing information as a touch location.

8. The method of claim 5, further comprising:

converting touch related sensing information with two peaks into touch related sensing information with one peak.

9. The method of claim 1, wherein the 2-D image includes: a plurality of dual differences;

a plurality of positive and negative values generated from the plurality of dual differences, wherein all the negative values of these dual differences are converted into zero values or all the positive values of these dual differences are converted into zero values; or

a plurality of positive and negative values generated from a plurality of differences, wherein all the negative values of these differences are converted into positive values or all the positive values of these differences are converted into negative values.

10. A device for analyzing 2-D image, comprising a controller and a host for performing an analysis, comprising:

analyzing a first 2-D image generated during scanning a touch panel once to determine each touch related sensing information with inner lower values within outer high values caused by one touch or approach of external conductive object in the first 2-D image, wherein the first 2-D image consists of a plurality of 1-D sensing informations on a plurality of parallel axes so as to represent signal distribution on a 2-D plane.

11. The device of claim 10, wherein the analysis further includes:

a sensing device including a plurality of sensors;

wherein the controller provides the 1-D sensing information each time it senses with the sensors, the controller further including the following operations:

constituting a second 2-D image from the 1-D sensing information; and

performing a conversion on positive or negative values of the second 2-D image to generate the first 2-D image, the conversion selected from one of the group consisting of: converting negative to positive values, converting positive to negative values, converting positive to zero values, and converting negative to zero values.

12. The device of claim 10, further comprising:

a sensing device including a plurality of sensors;

wherein the controller provides a 1-D sensing information each time it senses with the sensors, the first 2-D image constituted by the 1-D sensing information.

13. The device of claim 12, wherein the analysis further includes:

converting each touch related sensing information with inner lower values within outer high values into touch related sensing information with inner higher values within outer low values.

## 35

14. The device of claim 12, wherein the analysis further includes:

converting each touch related sensing information with a plurality of peaks into touch related sensing information with inner higher values within outer low values based on a corresponding portion in a second 2-D image. 5

15. The device of claim 10, wherein the analysis further includes:

analyzing the first 2-D image to determine each touch related sensing information with inner higher values within outer low values in the first 2-D image. 10

16. The device of claim 15, wherein the analysis further includes:

analyzing the contour of each touch related sensing information; and 15  
outputting geometric information based on each contour, wherein representation of the geometric information is selected from one or a combination of the following representations: circle, oval, rectangle and polygon. 20

17. The device of claim 15, wherein the analysis further includes:

calculating a centroid location or a geometric center of each touch related sensing information as a touch location. 25

18. The device of claim 15, further comprising:

converting touch related sensing information with two peaks into touch related sensing information with one peak.

## 36

19. The device of claim 10, wherein the 2-D image includes:

a plurality of dual differences;

a plurality of positive and negative values generated from the plurality of dual differences, wherein all the negative values of these dual differences are converted into zero values or all the positive values of these dual differences are converted into zero values; or

a plurality of positive and negative values generated from a plurality of differences, wherein all the negative values of these differences are converted into positive values or all the positive values of these differences are converted into negative values.

20. The device of claim 10, further comprising:

a sensing device including a plurality of sensors, wherein the controller provides a 1-D sensing information each time it senses with the sensors, and the host generating the 2-D image from the 1-D sensing information provided a plurality of times by the controller.

21. The device of claim 10, further comprising:

a sensing device including a plurality of sensors, wherein the controller provides a 1-D sensing information each time it senses with the sensors, and the host performing the analysis, and the controller performing the sensing with the sensors a plurality of times to provide the first 2-D image.

\* \* \* \* \*