



US008919050B2

(12) **United States Patent**
Zimmerman et al.

(10) **Patent No.:** **US 8,919,050 B2**
(45) **Date of Patent:** ***Dec. 30, 2014**

(54) **ANTI-TORSION CONSTRUCTION SYSTEM PROVIDING STRUCTURAL INTEGRITY AND SEISMIC RESISTANCE**

52/293.3, 223.13, 167.1, 94, 302.1, 199, 52/202, 203, 284, 285.1, 282.5, 289, 715
See application file for complete search history.

(71) Applicant: **SR Systems, LLC**, Tuscaloosa, AL (US)

(56) **References Cited**

(72) Inventors: **Steven Zimmerman**, Linden, AL (US);
Van T. Walworth, Lebanon, TN (US);
Scott Drummond, Tuscaloosa, AL (US)

U.S. PATENT DOCUMENTS

3,305,989 A * 2/1967 Scott 52/295
3,668,828 A * 6/1972 Nicholas et al. 52/92.1

(73) Assignee: **SR Systems, LLC**, Tuscaloosa, AL (US)

(Continued)

(*) Notice: Subject to any disclaimer, the term of this patent is extended or adjusted under 35 U.S.C. 154(b) by 0 days.

FOREIGN PATENT DOCUMENTS

JP 04327627 A * 11/1992 E04B 7/06
JP 06-306944 11/1994
JP 2009-293214 12/2009

This patent is subject to a terminal disclaimer.

OTHER PUBLICATIONS

(21) Appl. No.: **13/850,984**

International Search Report for PCT/US2012/055809 mailed Feb. 21, 2013.

(22) Filed: **Mar. 26, 2013**

(Continued)

(65) **Prior Publication Data**

US 2013/0247485 A1 Sep. 26, 2013

Primary Examiner — Brent W Herring

(74) *Attorney, Agent, or Firm* — Harness, Dickey & Pierce, P.L.C.

Related U.S. Application Data

(63) Continuation-in-part of application No. 13/613,441, filed on Sep. 13, 2012, now Pat. No. 8,726,581.

(60) Provisional application No. 61/685,793, filed on Mar. 26, 2012, provisional application No. 61/573,943, filed on Sep. 15, 2011.

(51) **Int. Cl.**
E04B 7/04 (2006.01)

(Continued)

(52) **U.S. Cl.**
CPC **E04H 9/00** (2013.01); **E04H 9/021** (2013.01); **E04H 9/14** (2013.01);

(Continued)

(58) **Field of Classification Search**
USPC 52/698, 90.1, 92.1, 93.1, 92.2, 93.2,

(57) **ABSTRACT**

A system for constructing a residential or commercial structure and/or retrofitting an existing structure provides a series of construction components employed that cooperate with standard construction materials to enhance the building structural integrity when subjected to destructive wind forces, torsion forces, and seismic forces, such as those commonly associated with hurricanes and tornados. The resultant strength of the structure is increased beyond what the standard construction materials were capable of on their own. The components further cooperate with standard construction materials to provide a unitized system of structural integrity. The components further cooperate with a secondary water sealing ability to minimize and/or prevent influent water damage to the structure in the event that the primary sealing system is compromised.

19 Claims, 21 Drawing Sheets

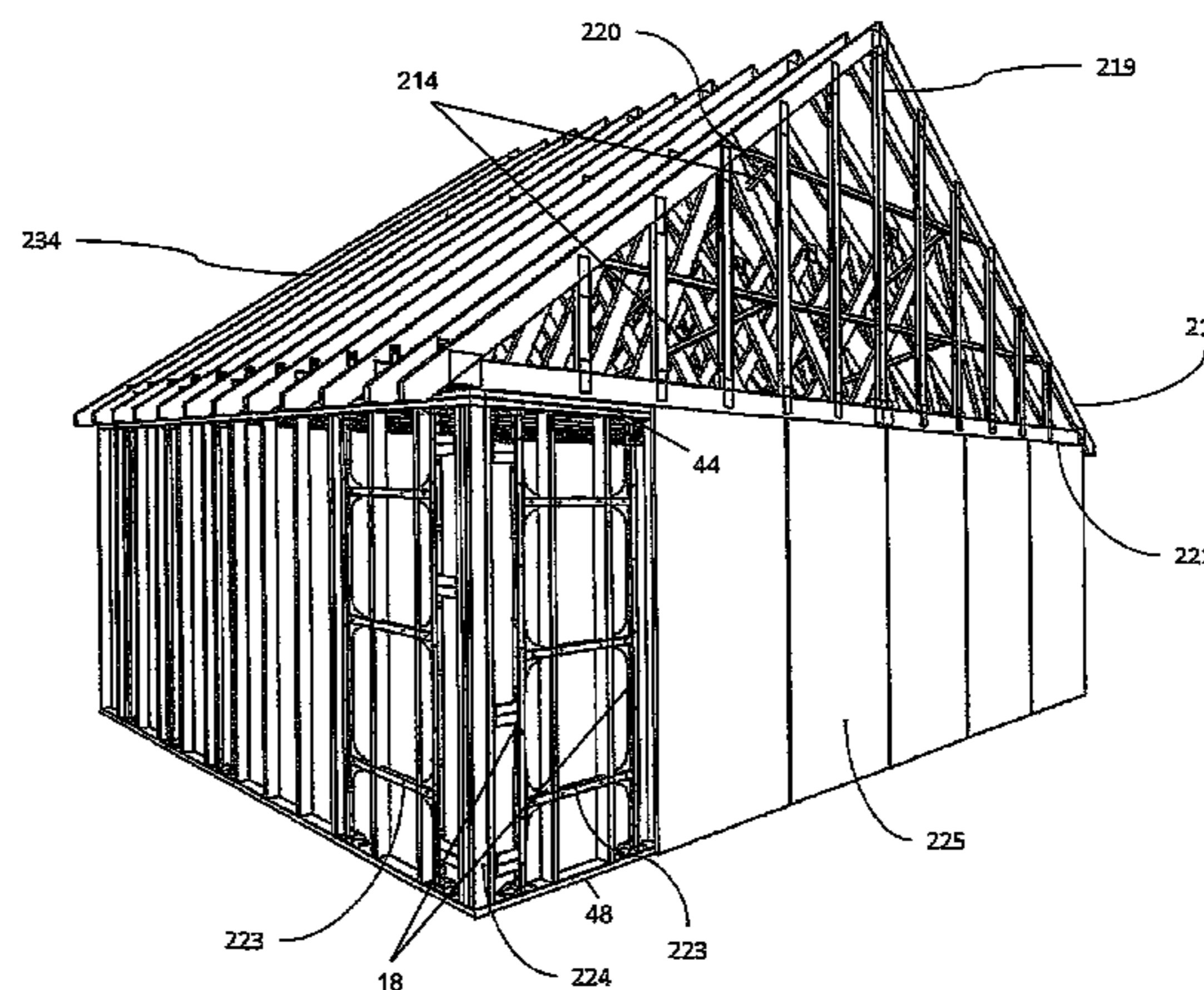
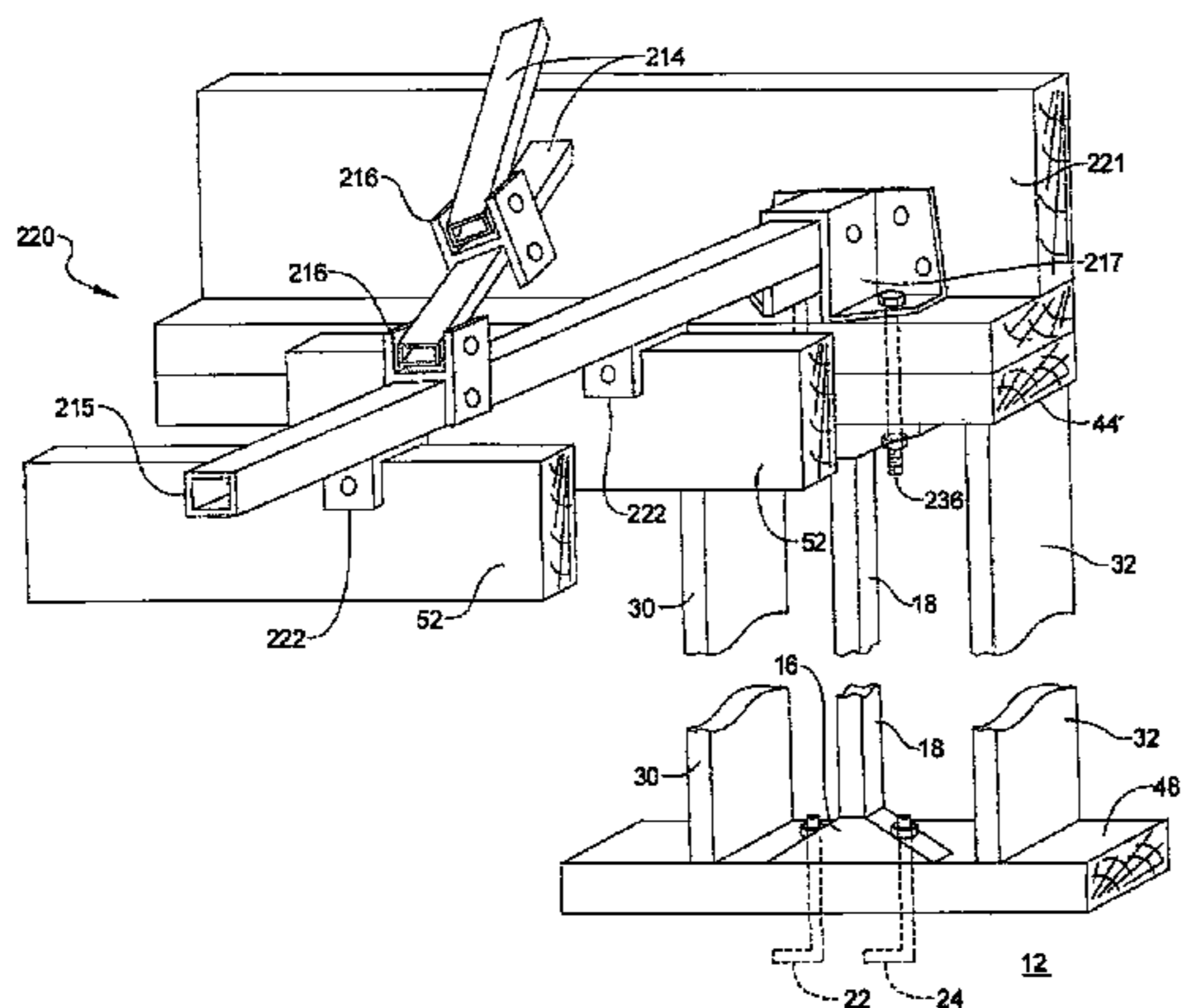

(51) **Int. Cl.**
E04H 9/00 (2006.01)
E04H 9/02 (2006.01)
E04H 9/14 (2006.01)
E02D 27/00 (2006.01)
E04B 1/26 (2006.01)
E04B 1/92 (2006.01)
E06C 1/34 (2006.01)

(52) **U.S. Cl.**
 CPC *E02D 27/00* (2013.01); *E04B 1/26* (2013.01); *E04B 1/92* (2013.01); *E04B 7/045* (2013.01); *E06C 1/345* (2013.01); *E04H 9/027* (2013.01); *E04B 1/2608* (2013.01); *E04B 2001/2684* (2013.01); *E04B 2001/2696* (2013.01); *E04B 1/2604* (2013.01)
 USPC 52/92.2; 52/698; 52/293.3; 52/167.1; 52/285.1

(56) **References Cited**
 U.S. PATENT DOCUMENTS

3,755,982	A *	9/1973	Schmidt	52/295
3,785,108	A *	1/1974	Satchell	52/645
3,902,280	A *	9/1975	Spoar et al.	52/91.1
3,963,210	A *	6/1976	Macklin	249/210
3,964,268	A *	6/1976	DiPeri	62/121
4,073,103	A *	2/1978	McClure	52/93.1
4,198,175	A *	4/1980	Knepp et al.	403/191
4,321,776	A *	3/1982	Delight	52/167.1
4,420,913	A *	12/1983	Long et al.	52/57
4,455,792	A *	6/1984	Pasco	52/93.2
4,872,298	A	10/1989	Klemic	
4,875,314	A *	10/1989	Boilen	52/167.1
4,890,436	A *	1/1990	Colonias	52/643
4,982,545	A *	1/1991	Stromback	52/639
5,050,364	A	9/1991	Johnson et al.	
5,060,436	A	10/1991	Delgado	
5,240,224	A	8/1993	Adams	
5,317,850	A	6/1994	Colonias et al.	
5,327,699	A *	7/1994	Khan et al.	52/93.2
5,349,800	A *	9/1994	Peng	52/506.06
5,384,993	A	1/1995	Phillips	
5,388,804	A	2/1995	Cohen et al.	
5,448,861	A *	9/1995	Lawson	52/92.2
5,487,244	A *	1/1996	Hill	52/202
5,491,935	A	2/1996	Coxum	
5,699,639	A *	12/1997	Fernandez	52/707
5,836,132	A	11/1998	Weathersby	
5,881,501	A *	3/1999	Guffey et al.	52/90.1
6,003,271	A *	12/1999	Boyer et al.	52/79.5
6,014,843	A *	1/2000	Crumley et al.	52/167.3
6,065,730	A	5/2000	Marks et al.	
6,161,339	A *	12/2000	Cornett et al.	52/23
6,256,960	B1 *	7/2001	Babcock et al.	52/592.1
6,332,299	B1 *	12/2001	Stewart, III	52/696
6,347,916	B1	2/2002	Ramirez	
6,367,205	B2 *	4/2002	Cornett, Sr.	52/23
6,430,881	B1 *	8/2002	Daudet et al.	52/92.2
6,691,488	B2 *	2/2004	Branson	52/745.01
6,763,634	B1 *	7/2004	Thompson	52/92.2
6,922,968	B1	8/2005	Behlen	
7,103,984	B2	9/2006	Kastberg	
7,140,155	B1 *	11/2006	Nasimov	52/236.8
7,150,132	B2 *	12/2006	Commins	52/293.3
7,174,689	B2	2/2007	Alyea et al.	
7,200,972	B1 *	4/2007	Freeman et al.	52/641
7,398,620	B1 *	7/2008	Jones	52/92.2
7,445,192	B2	11/2008	Gridley et al.	
7,448,172	B1	11/2008	Knodel	
7,788,878	B1 *	9/2010	diGirolamo et al.	52/745.19
7,971,110	B2	2/2011	Diaz	
7,971,411	B2 *	7/2011	Commins	52/745.21
8,046,966	B2 *	11/2011	Moore et al.	52/506.06
8,065,846	B2 *	11/2011	McDonald et al.	52/281
8,091,291	B2 *	1/2012	Ode	52/93.1
2003/0024174	A1	2/2003	Bonds et al.	
2003/0182875	A1 *	10/2003	Hill	52/92.1
2004/0049993	A1 *	3/2004	Saldana	52/90.2
2005/0086888	A1 *	4/2005	Moore et al.	52/506.06
2006/0254166	A1 *	11/2006	Michels et al.	52/270
2006/0254167	A1	11/2006	Antonic	
2007/0094992	A1 *	5/2007	Antonic	52/656.1
2010/0236158	A1 *	9/2010	Carbonaro	52/92.1
2013/0067839	A1 *	3/2013	Zimmerman et al.	52/293.3

OTHER PUBLICATIONS

Written Opinion of the International Searching Authority for PCT/US2012/055809 mailed Feb. 21, 2013.
 International Search Report for PCT/US2013/033936 mailed Jul. 18, 2013.
 Written Opinion of the International Searching Authority for PCT/US2013/033936 mailed Jul. 18, 2013.

* cited by examiner

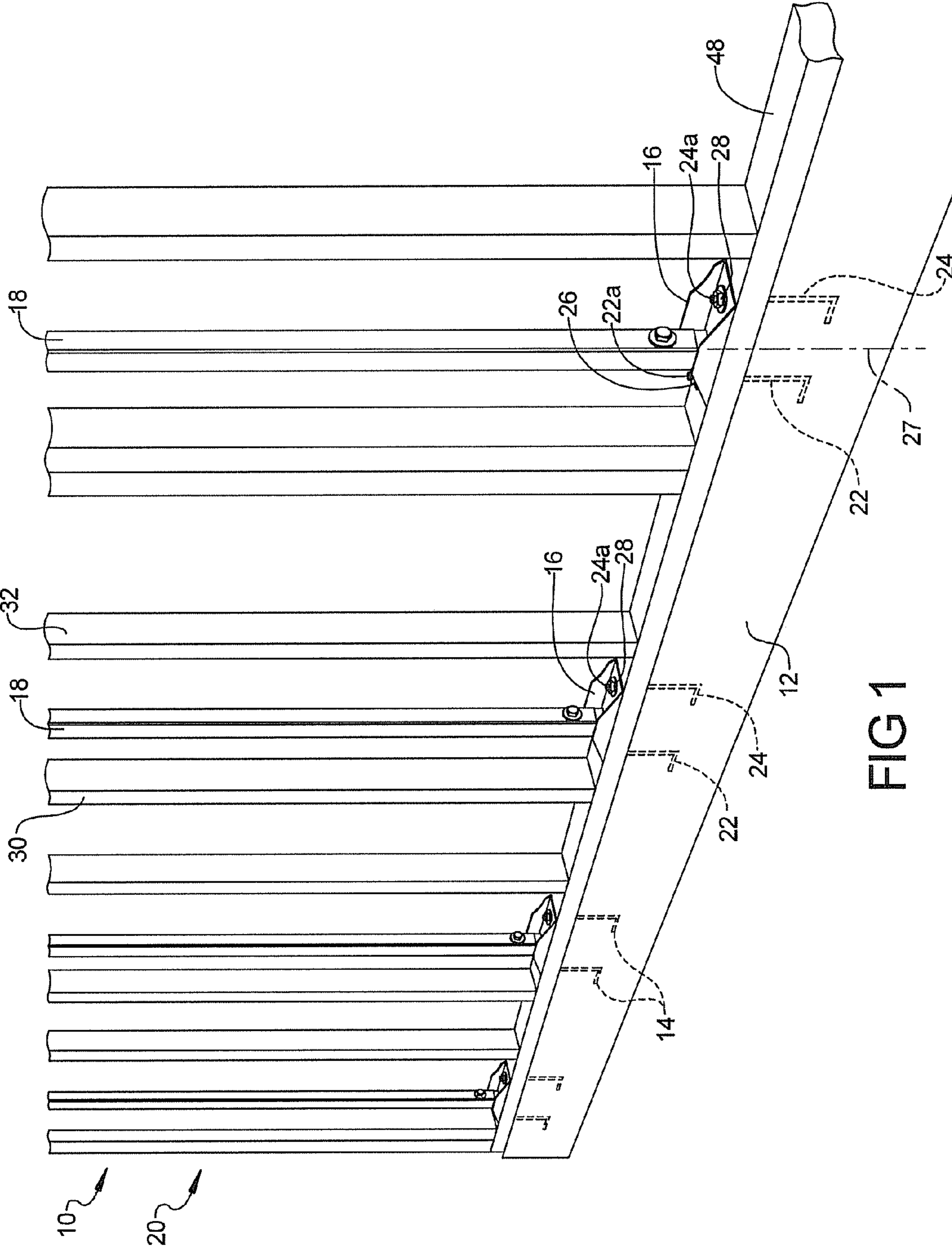

FIG 1

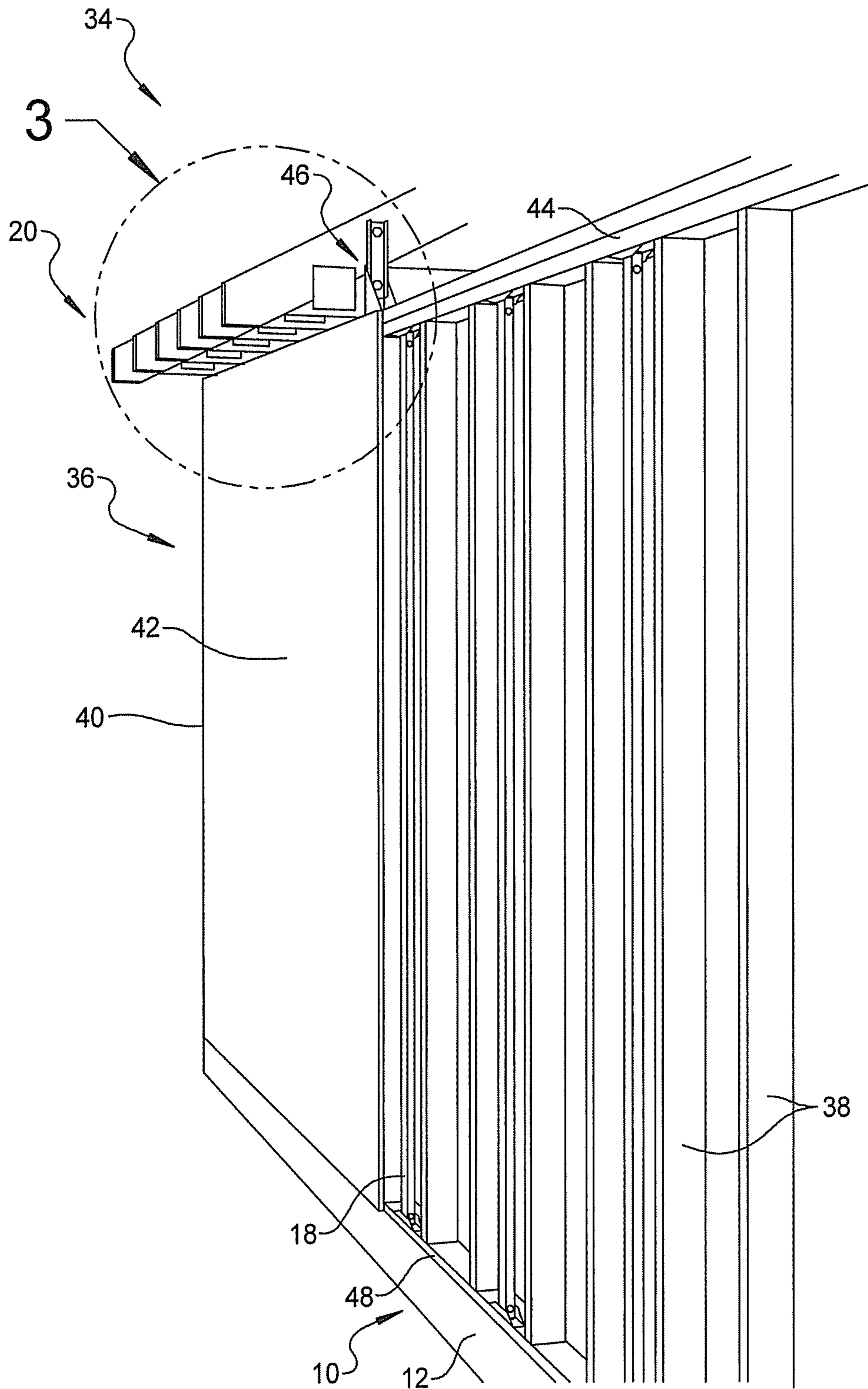

FIG 2

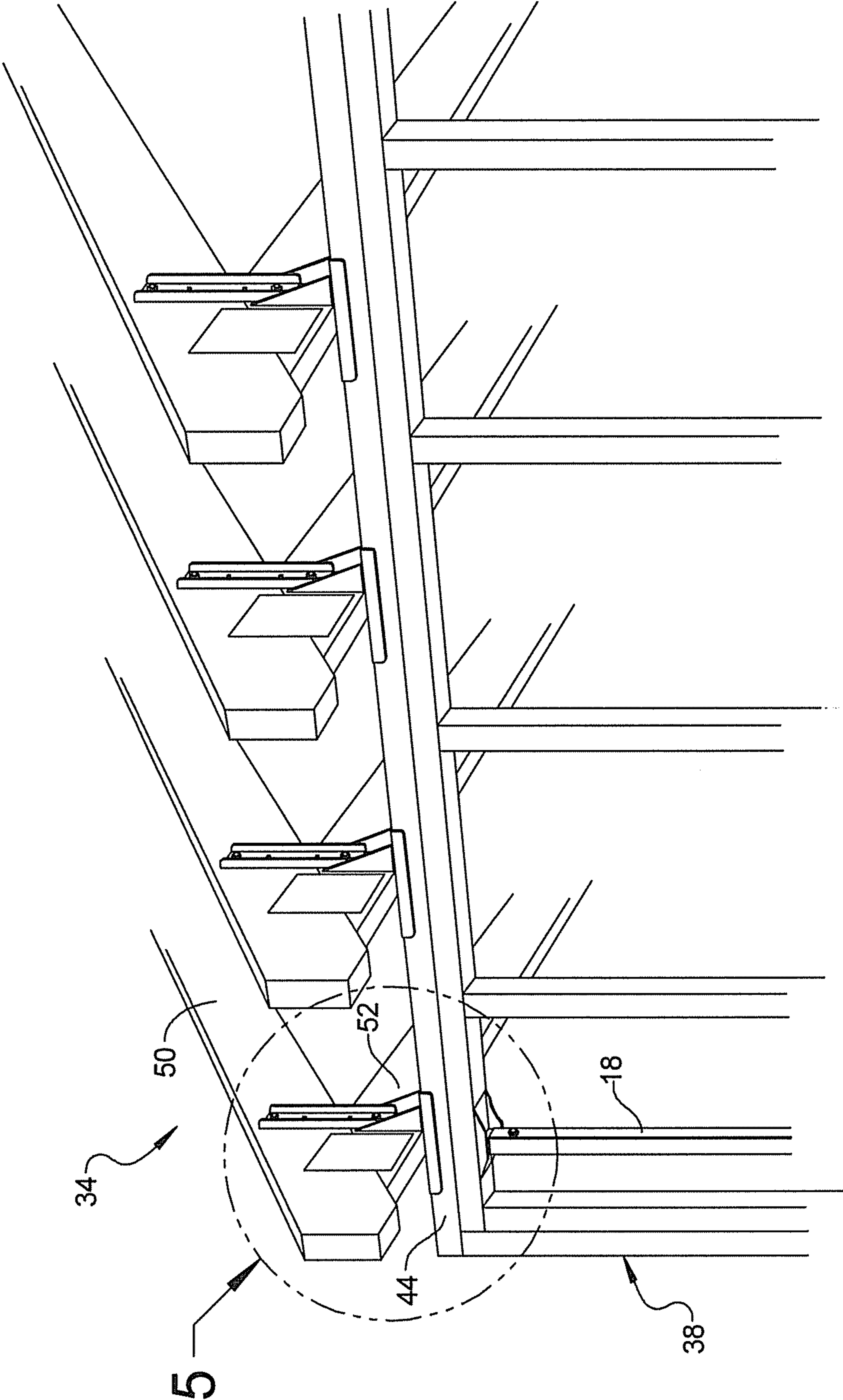

FIG 3

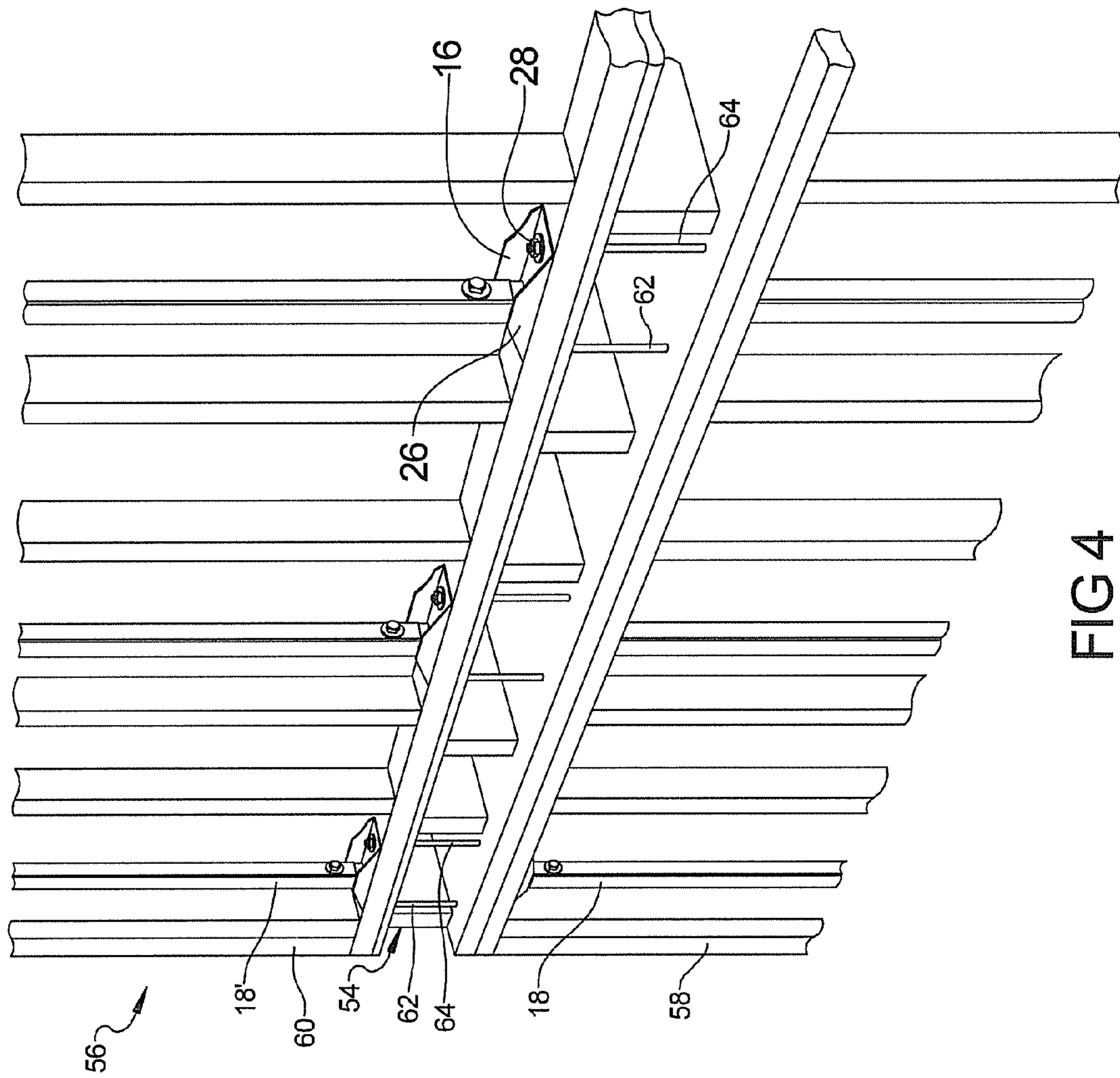

FIG 4

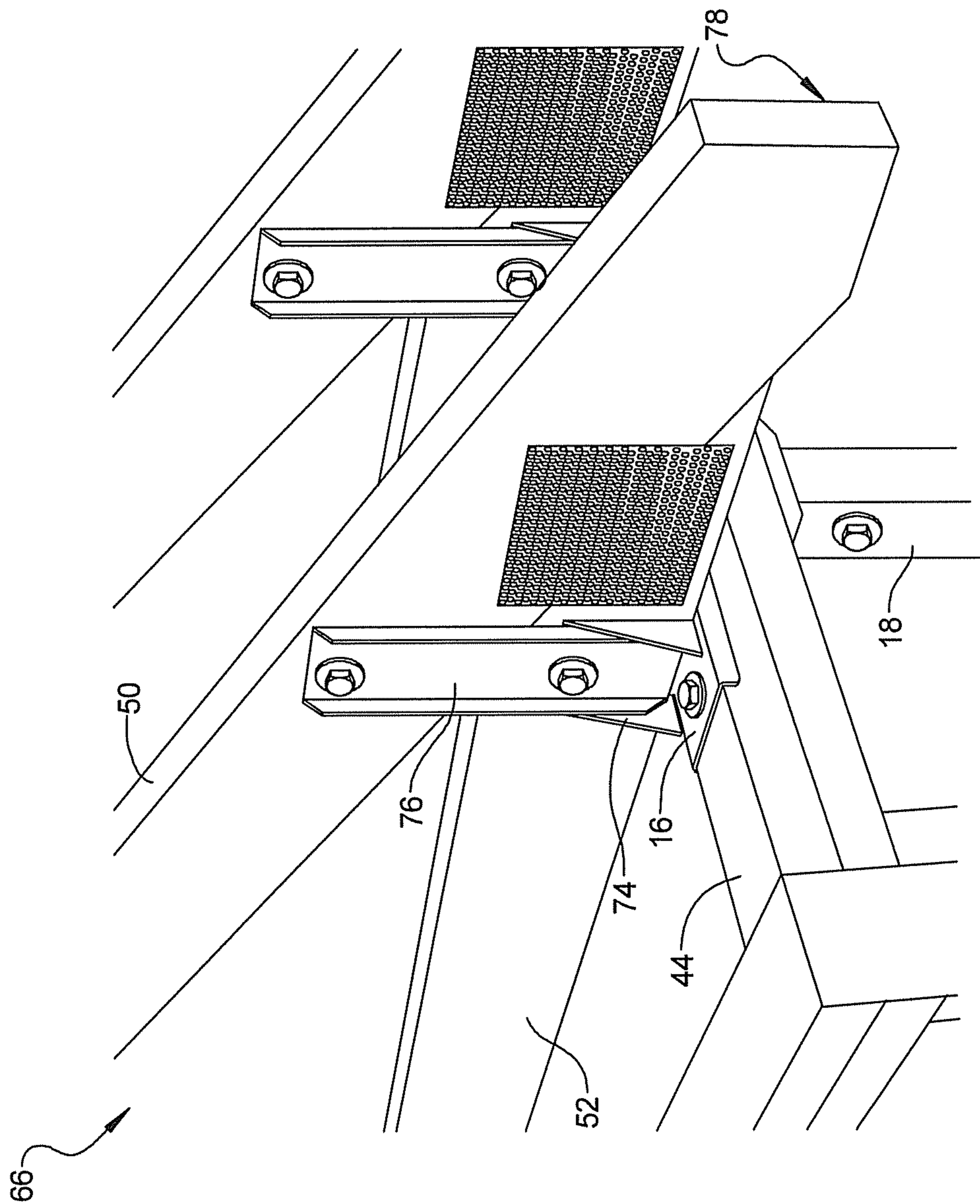

FIG 5

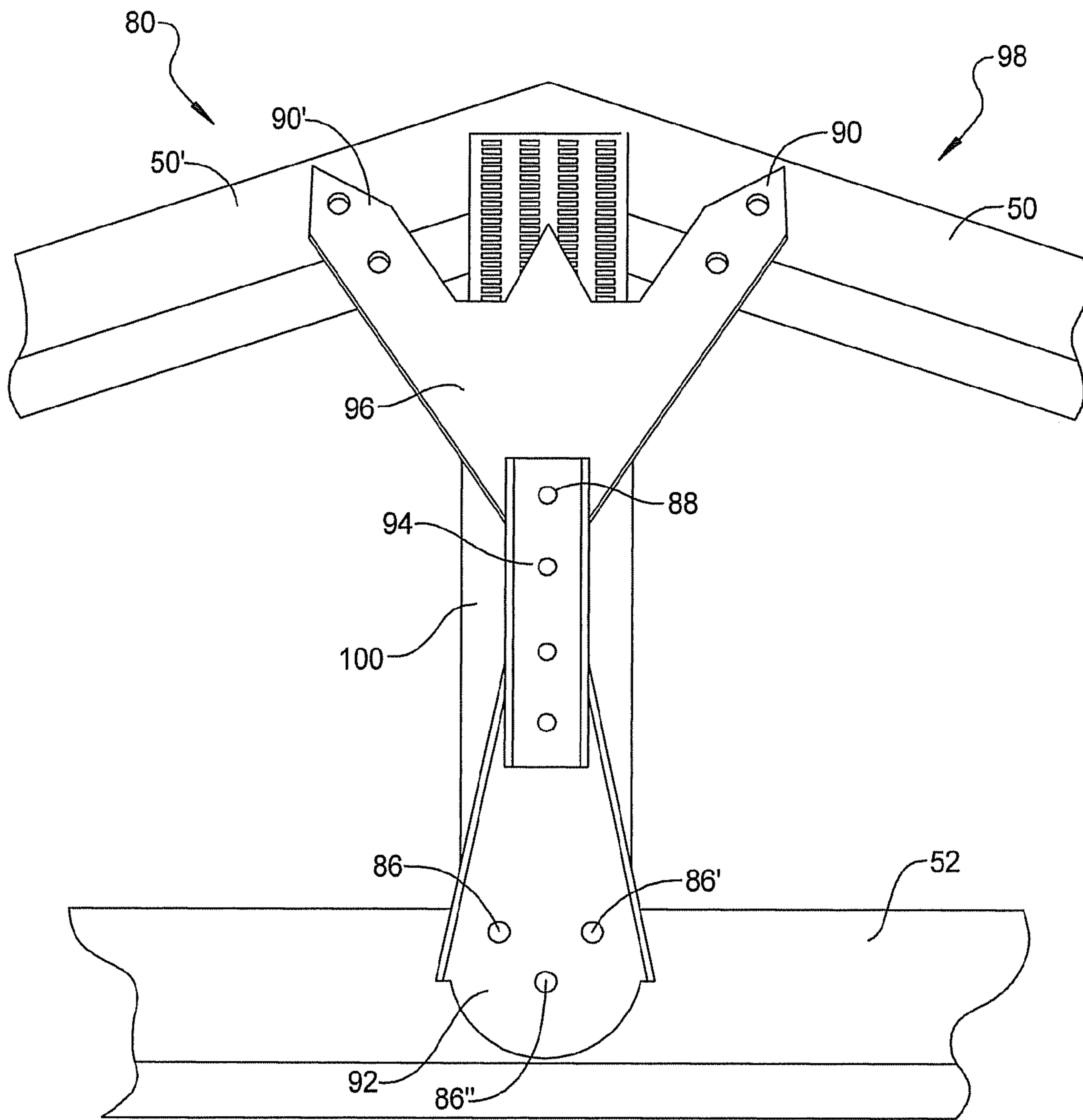

FIG 6

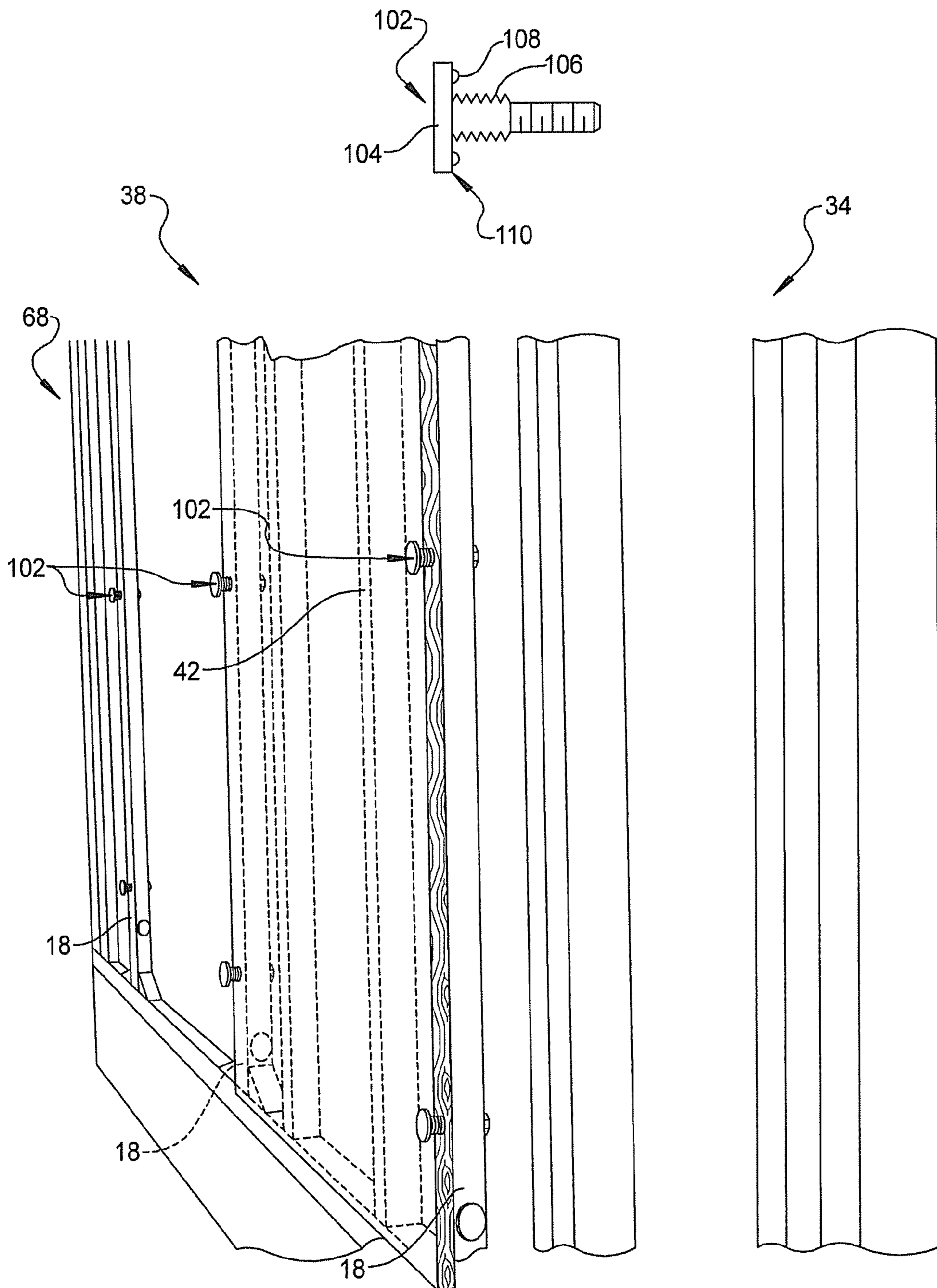

FIG 7



FIG 8

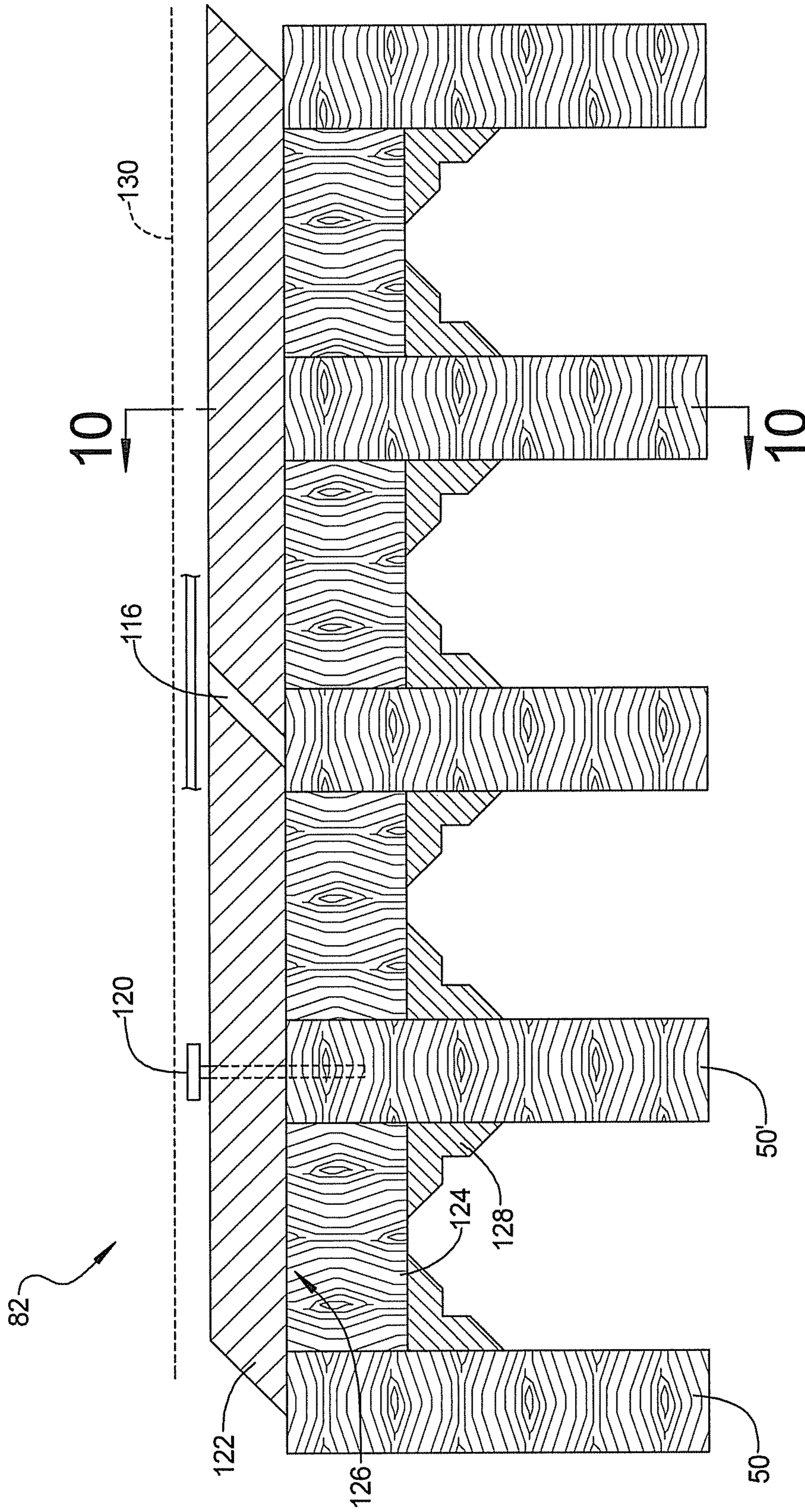

FIG 9

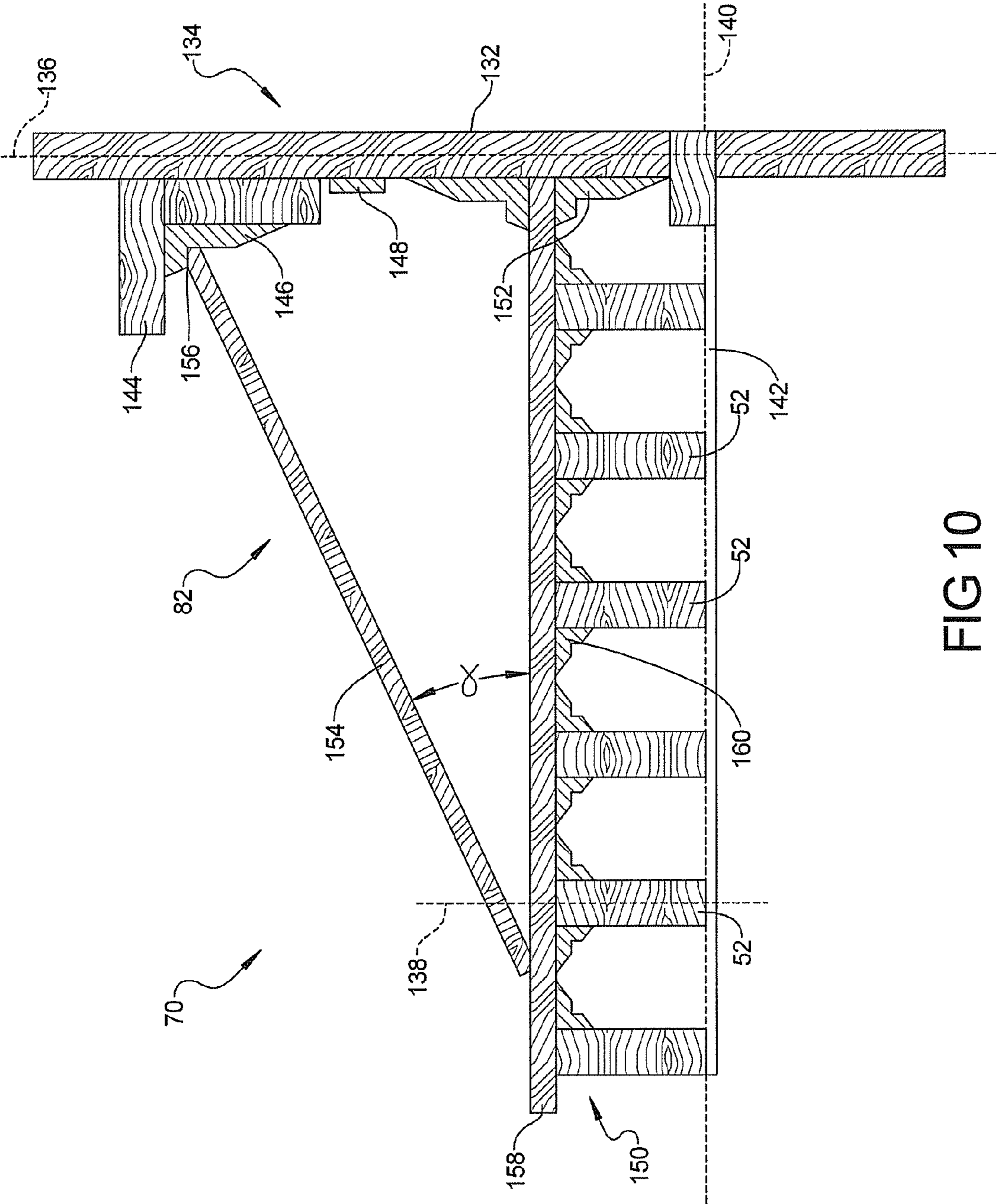

FIG 10

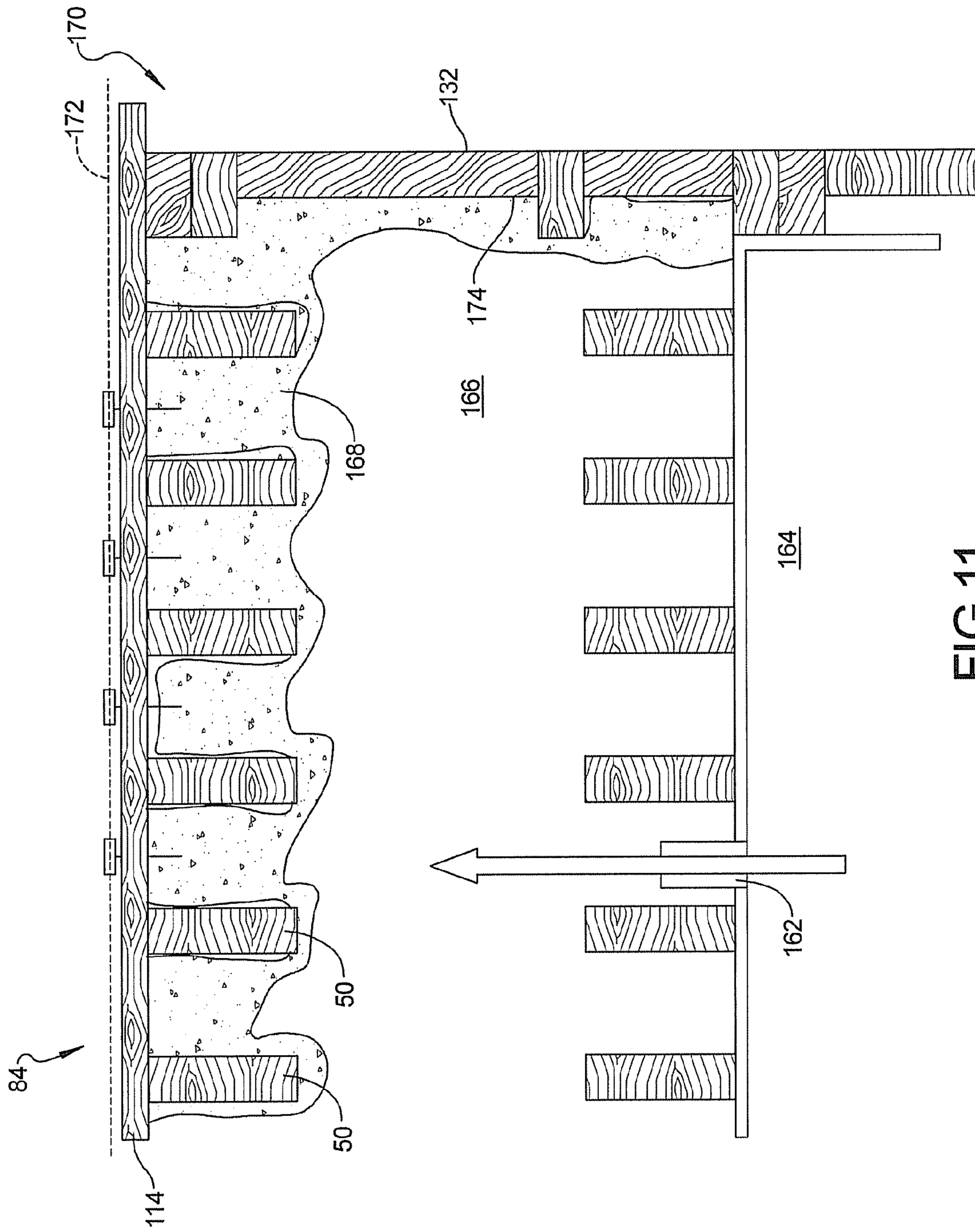

FIG 11

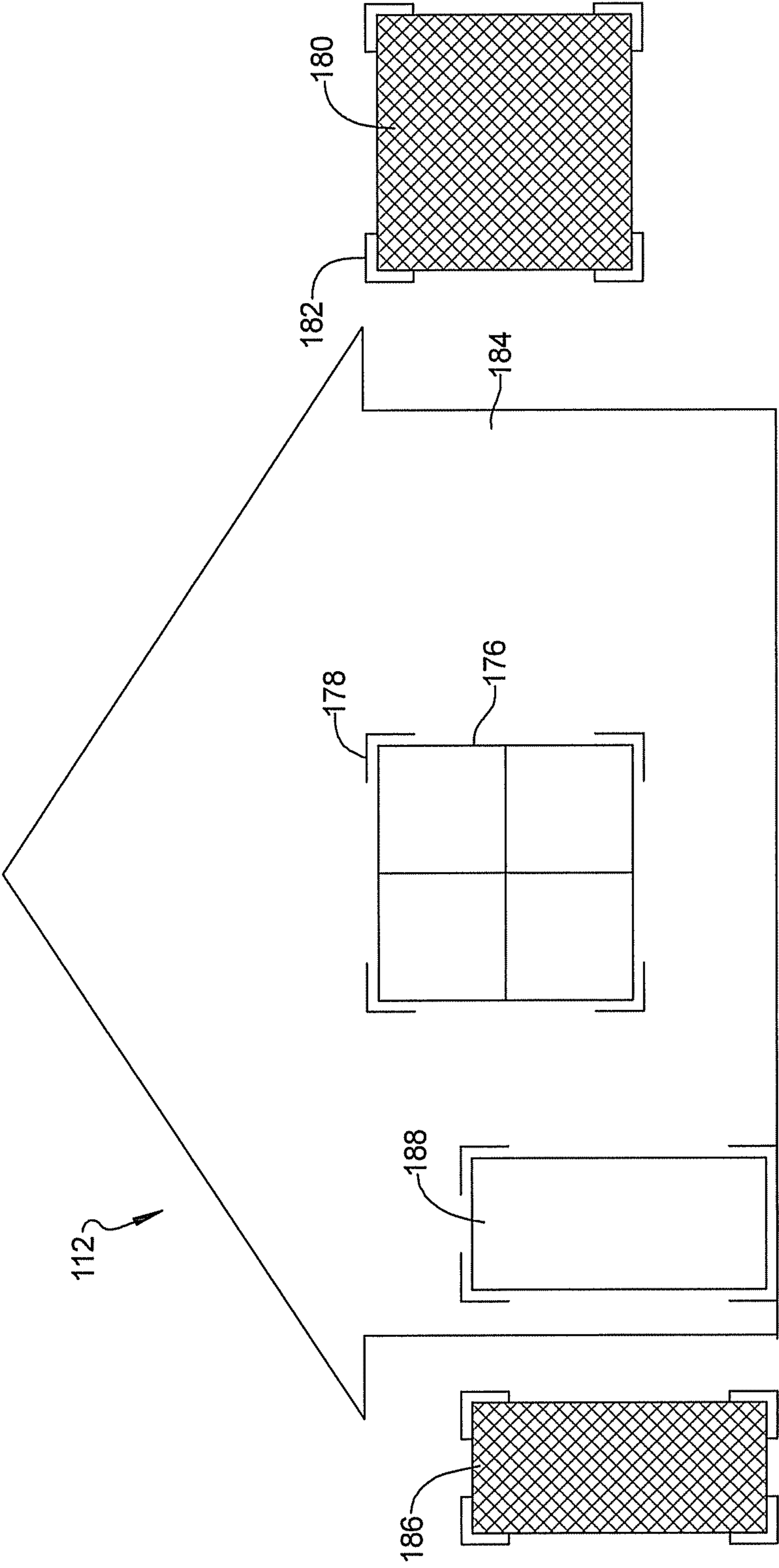

FIG 12

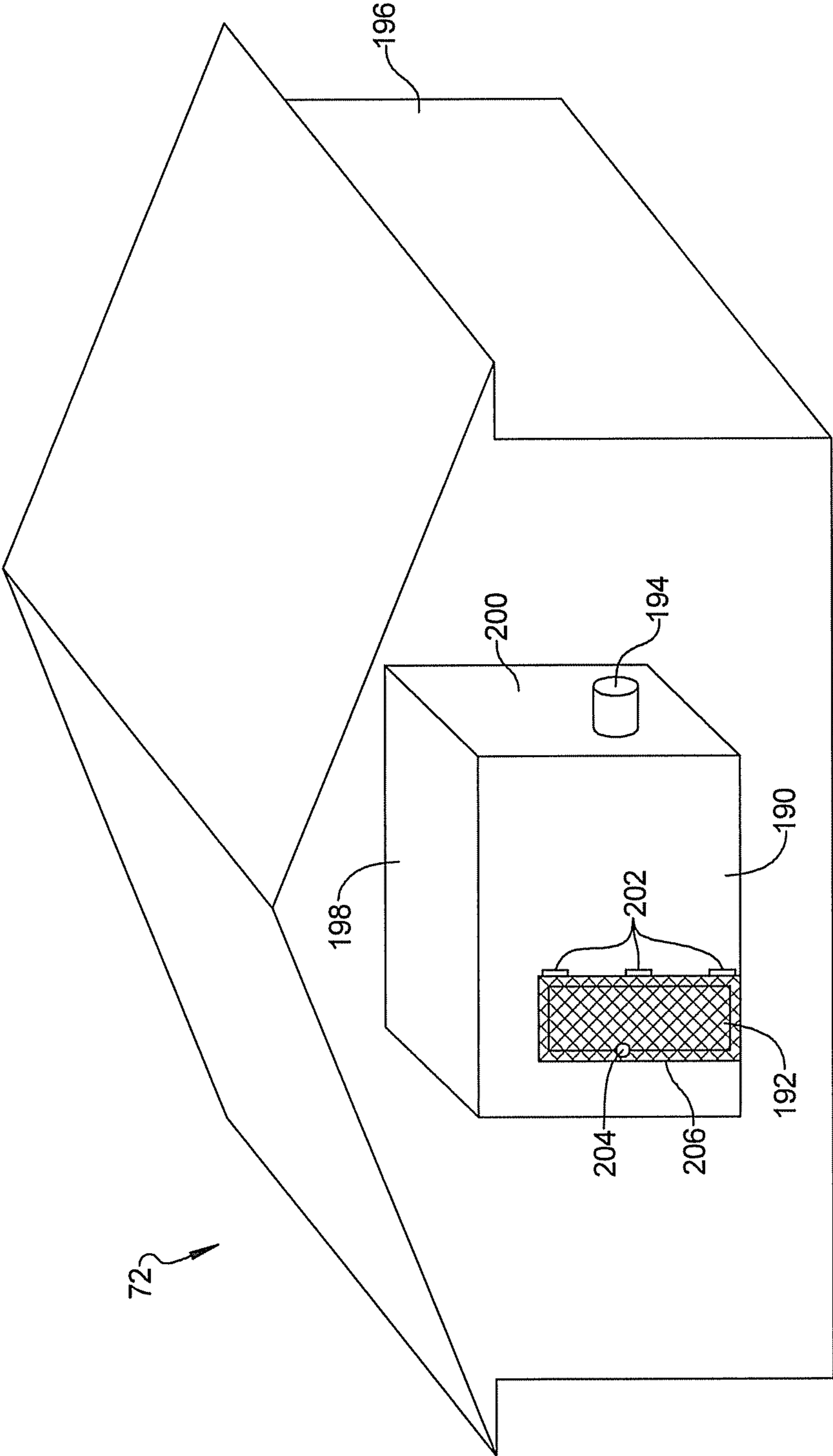

FIG 13

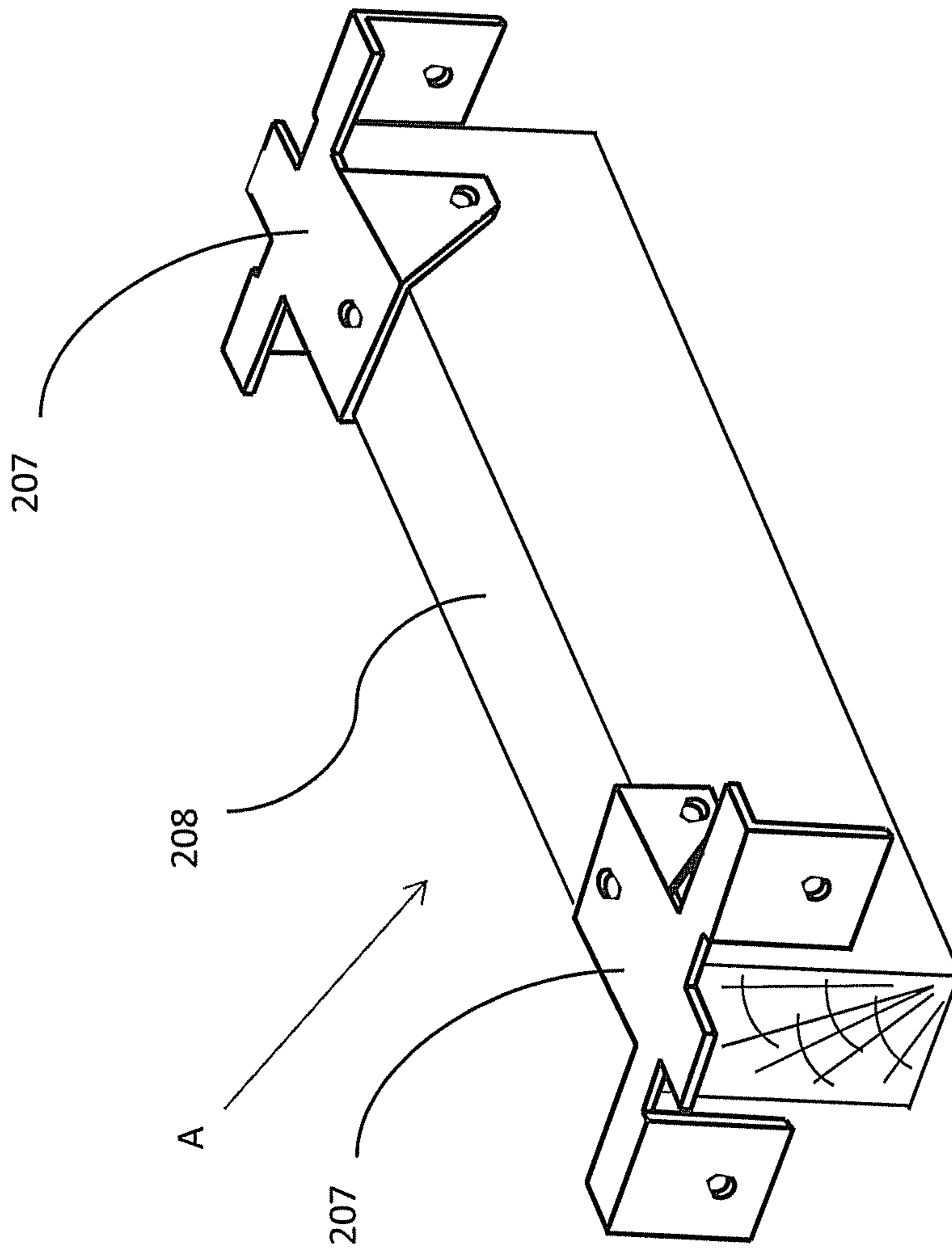

Fig. 14

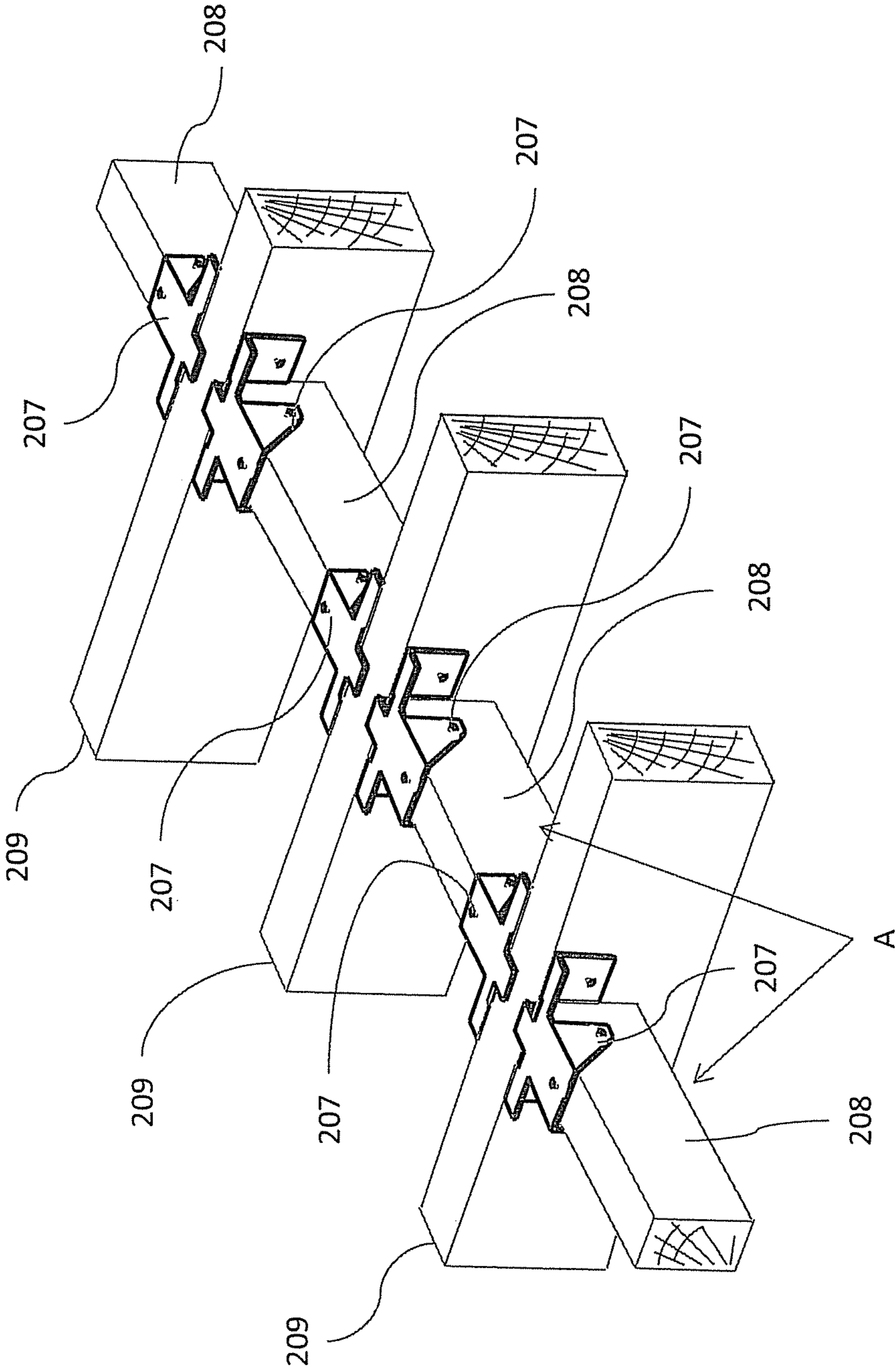

Fig.15

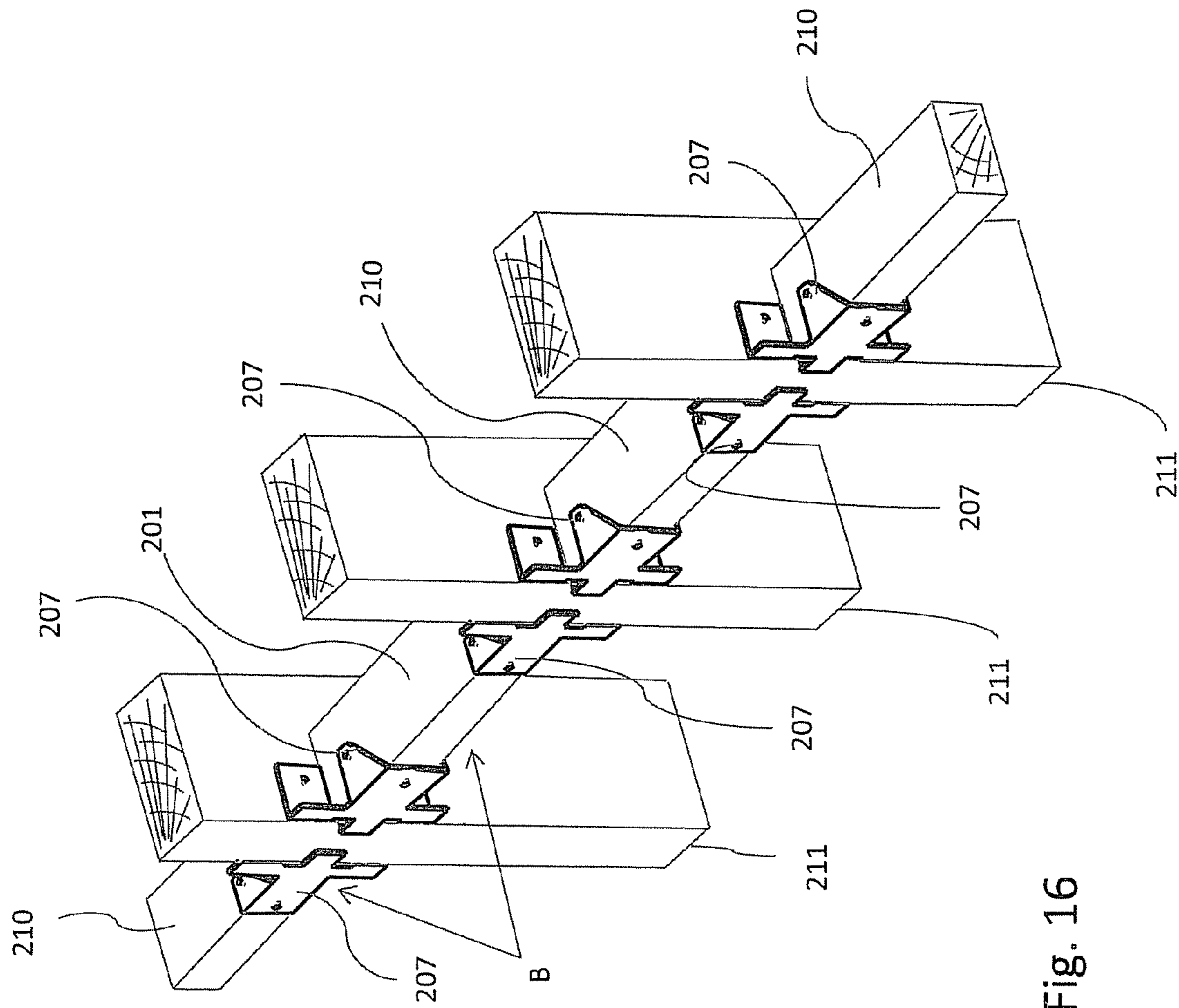

Fig. 16

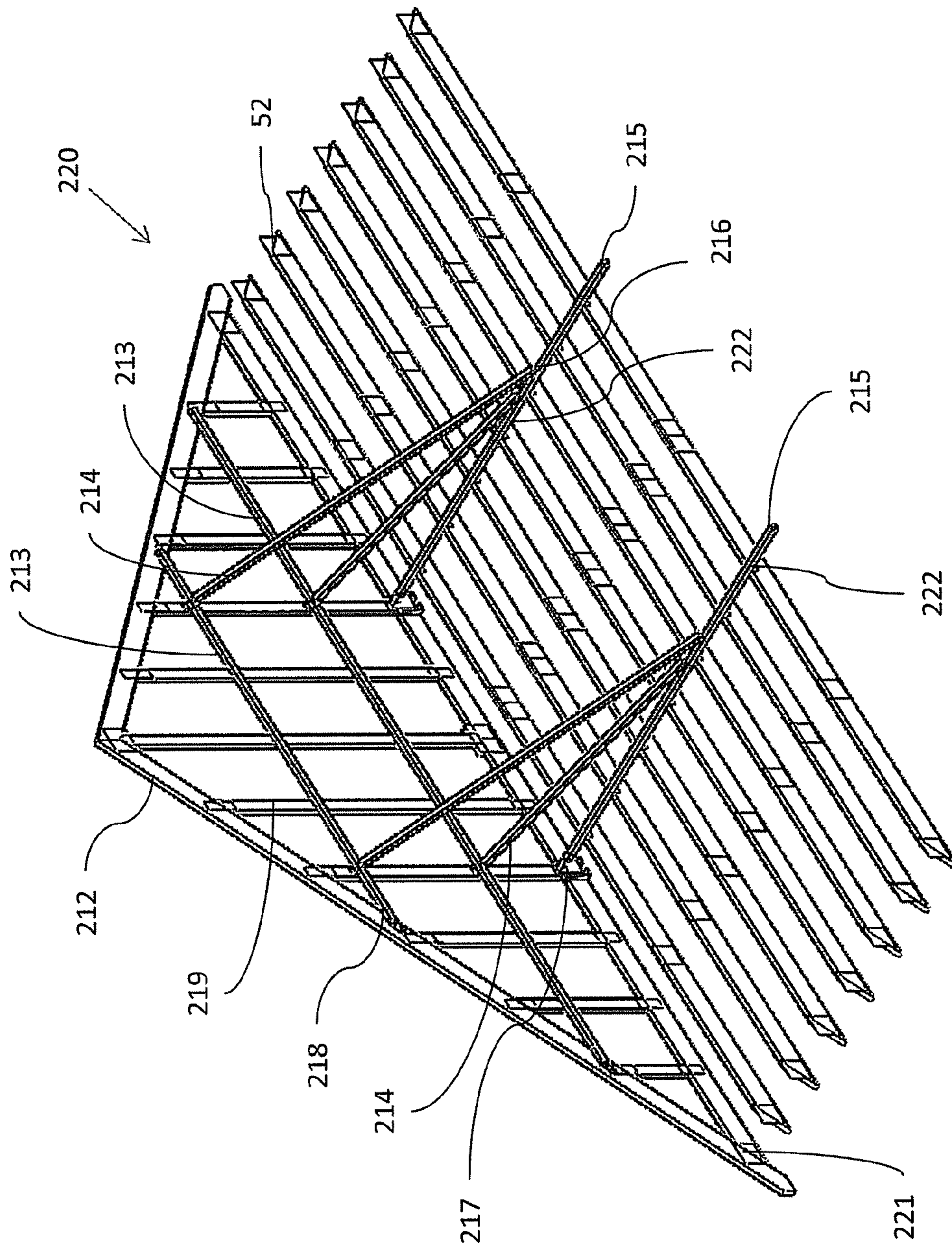

Fig. 17

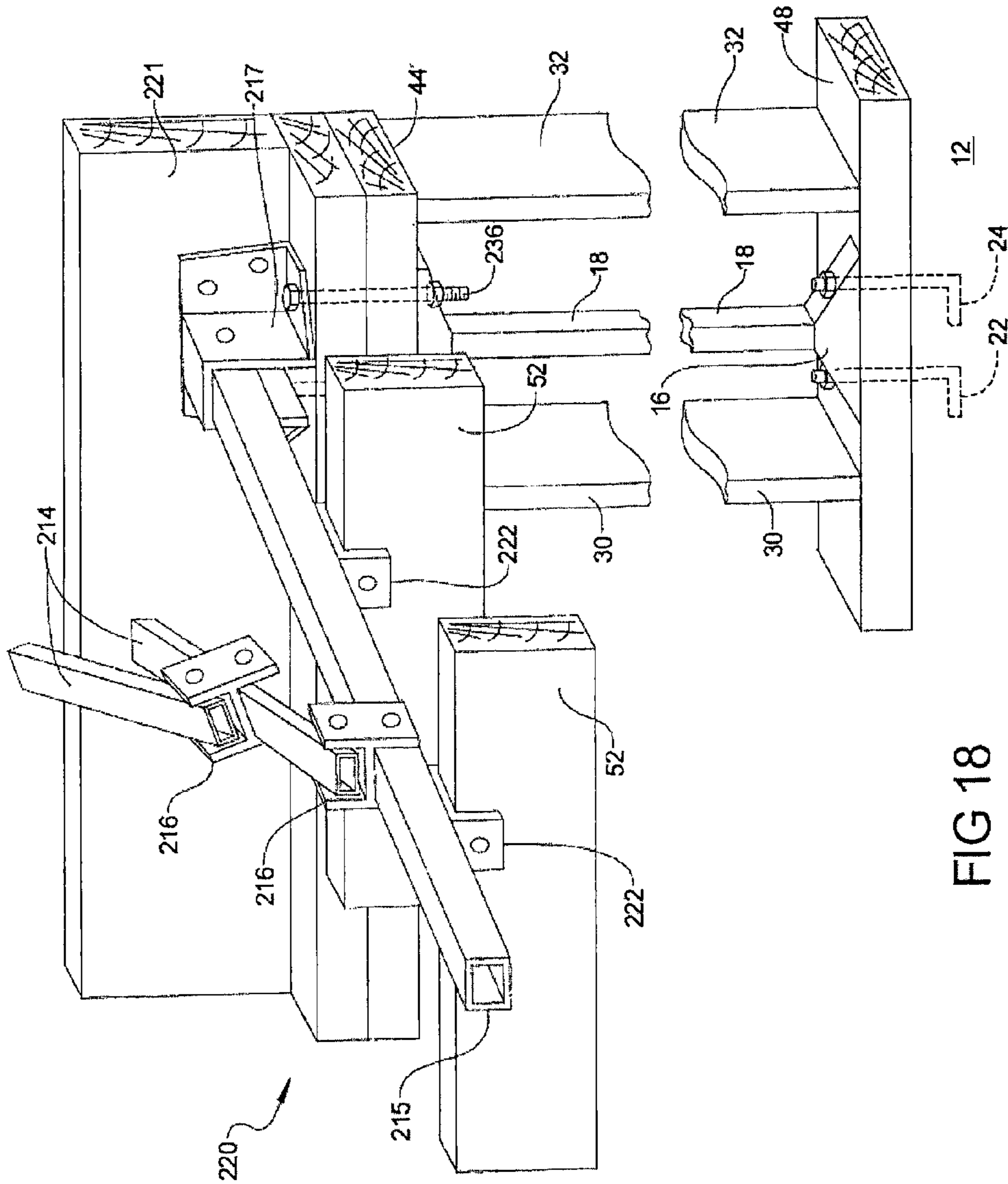

FIG 18

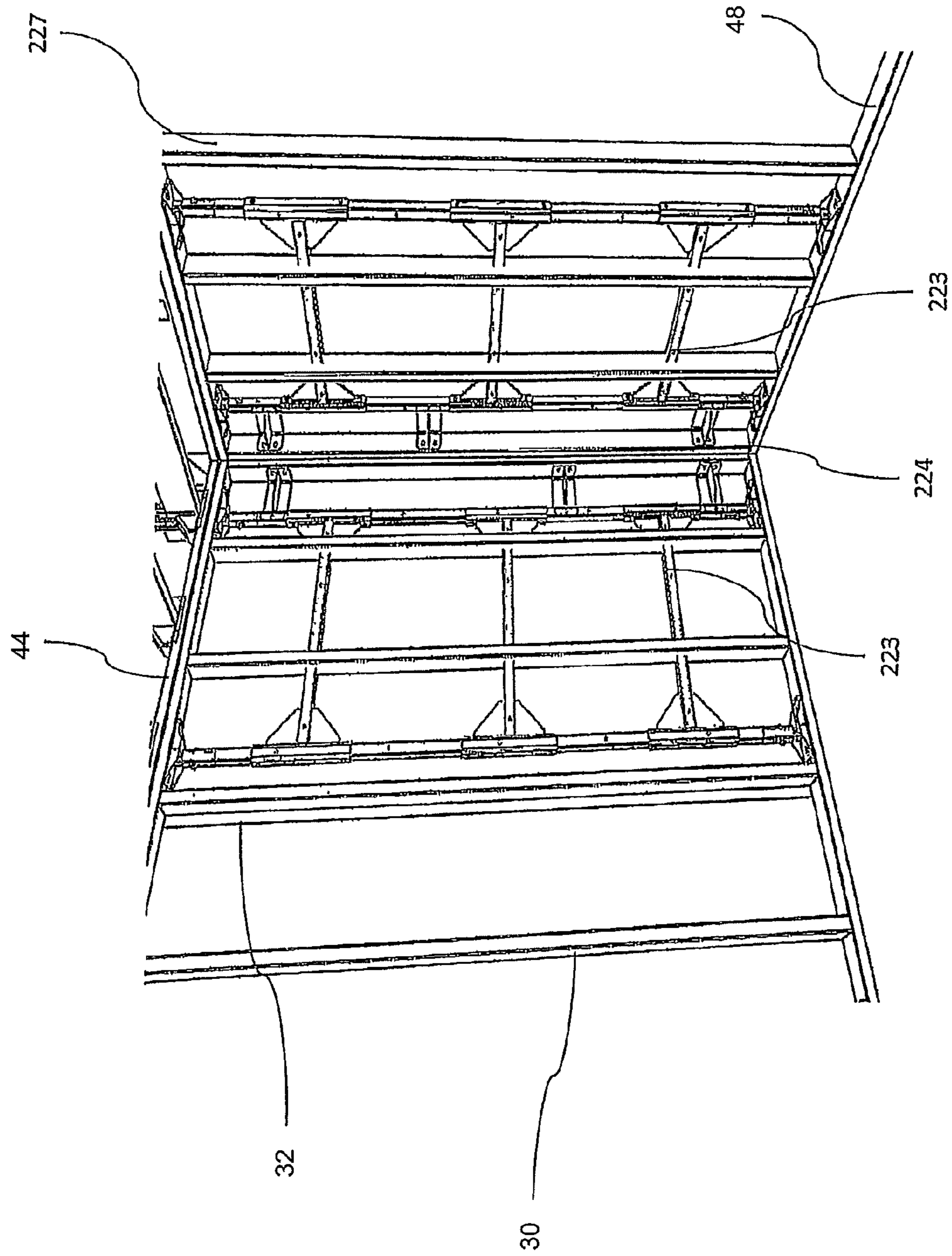

Fig. 19

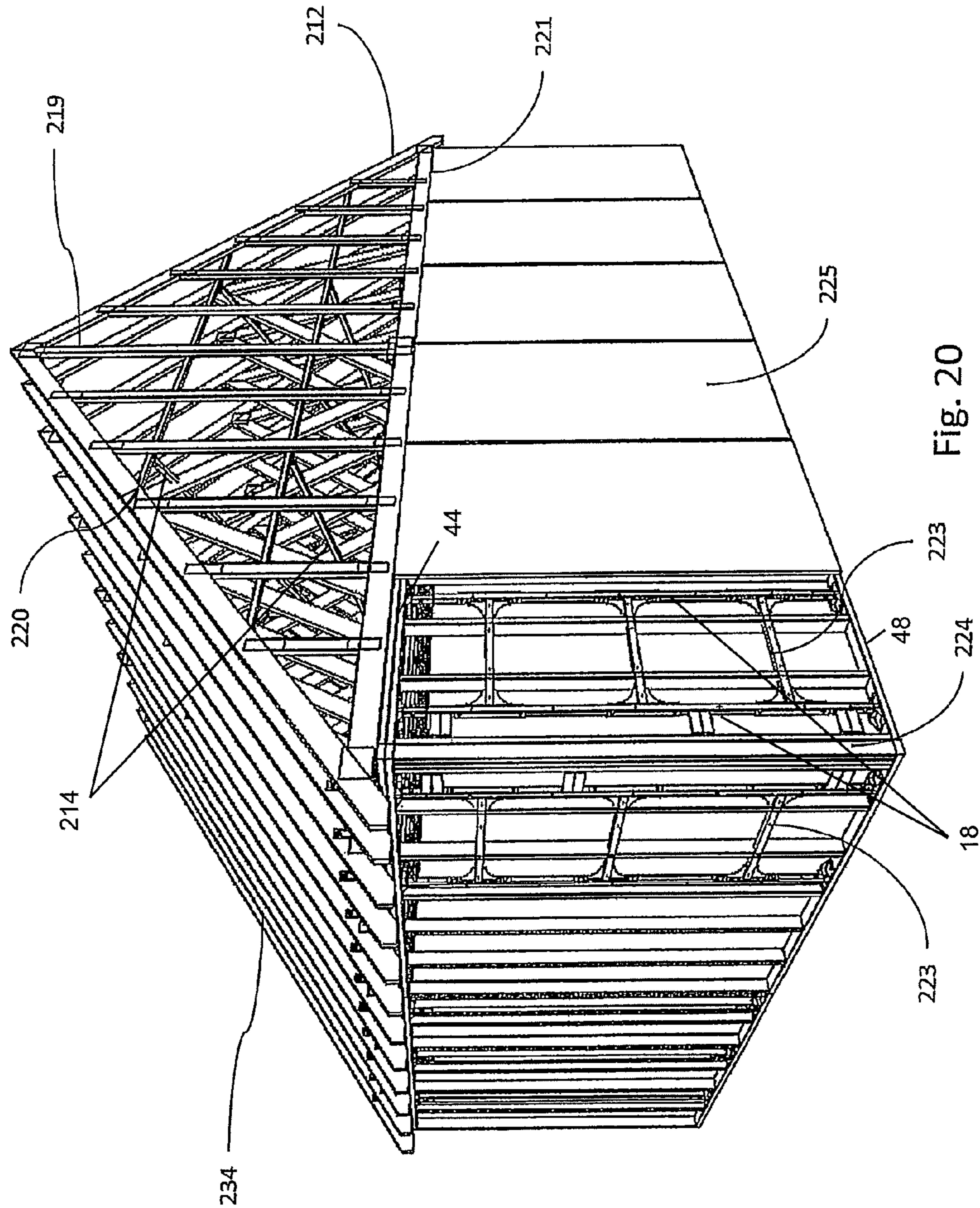

Fig. 20

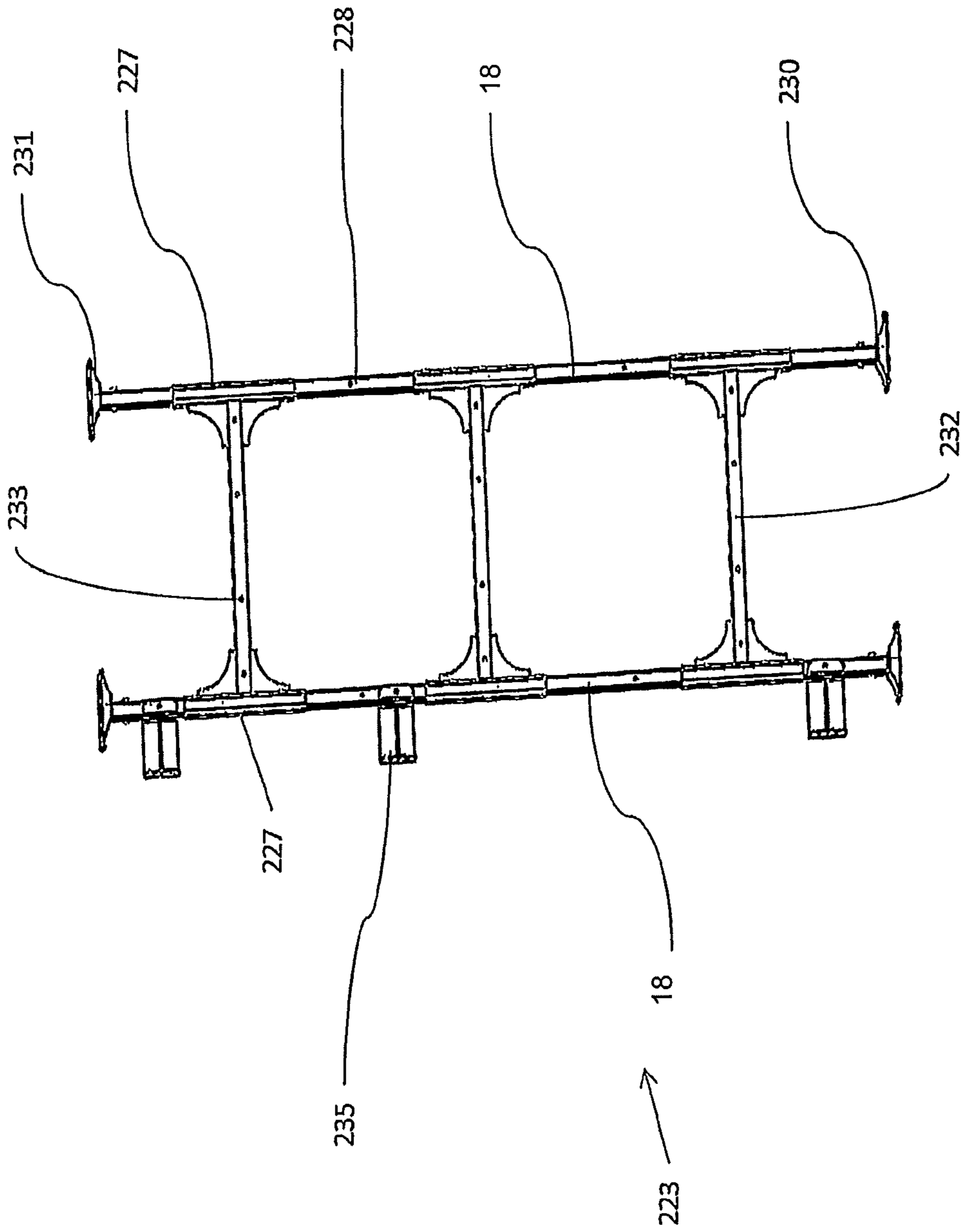

Fig. 21

1

**ANTI-TORSION CONSTRUCTION SYSTEM
PROVIDING STRUCTURAL INTEGRITY AND
SEISMIC RESISTANCE**

CROSS-REFERENCE TO RELATED
APPLICATIONS

This application is a continuation-in-part of U.S. patent application Ser. No. 13/613,441, filed on Sep. 13, 2012, which claims the benefit of U.S. Provisional Application No. 61/685,793, filed on Mar. 26, 2012, which claims the benefit of U.S. Provisional Application No. 61/573,943, filed on Sep. 15, 2011. The entire disclosures of the above applications are incorporated herein by reference.

FIELD

The present disclosure relates to storm resistant components and residential or commercial structures enhanced to resist the damaging forces imposed by storm winds, storm rains, torsion forces, and seismic events.

BACKGROUND

This section provides background information related to the present disclosure which is not necessarily prior art.

It is well known that hurricanes and tornados create storm wind forces capable of damaging and/or destroying standard residential and commercial constructions. Wind storm forces are known to remove and/or compromise the primary sealing systems of shingles, roofing, siding, and veneers. Furthermore, wind storm forces are well known to lift off entire roof systems and blow down and/or suck out walls.

The winds associated with tornado and hurricane storms are known to include destructive straight line winds and other destructive forces that impose torsion forces upon a structure to effectively twist it apart. In addition, tornado and hurricane storms buffet structures with seismic type forces that effectively weaken the holding power of traditional fasteners like nails and screws. Furthermore, tornado storms include a vortex, and sometimes several smaller vortices inside of a large vortex, which impose a spiraling shell of wind capable of imposing an effective dynamic wall of wind known to apply impact forces to a structure, capable of effectively bumping and/or knocking it down, not just blowing it down.

Observations of tornado storm events suggest that a vortex travels while spinning in an unorthodox, unpredictable, and indefinable warble-like pattern and/or path. The warble-like pattern of movement relative to the ground gives the spinning wind wall impact like force acting on a structure as it whips around with sudden changes of direction. As a result, frame-type structures usually suffer significant damage from direct hits by a tornado, regardless of the size or classification of the storm.

In addition, wind storm forces are well known to impose substantial blowing rain events which become influent to structures even before the construction components fail and/or are compromised. Beyond the obvious influent opportunities resulting from broken windows and/or other compromised construction components, wind storm events are known to blow rain into and through functioning vents of an intact roof system, thus creating water damage even though little or no actual structural damage occurs.

In addition to wind and rain hazards, severe wind events impose seismic forces upon buildings, not unlike the seismic forces imposed by an earthquake. One of the reasons that frame-type buildings seem to explode apart is partly because

2

the fasteners, which are traditionally nails and/or screws, significantly weakened lose their holding power when subjected to seismic forces. As a result, once the holding power of traditional nails and screws is compromised, subsequent applied forces of wind, rain, torsion, and/or seismic in nature, can have significant destructive impact upon a structure.

There are numerous representatives of known art resident in the patent records that deal with various hurricane or tornado storm wind forces by claiming use of any one of several strengthening components. However, one of the major problems with all of the known examples is that they do not lend themselves to our do-it-yourself culture and do not lend themselves to be cost effective for the mass consumption public at large.

Another problem with known art examples is that none of these patent records for structural strengthening systems includes a means to provide a secondary sealing system for the structure in the event the primary sealing system of shingles and/or siding of the structure are compromised.

Another problem with the known art examples is that none of these patent records for structural strengthening systems includes a means to provide anti-torsion and seismic resistance to the construction system by unitizing the basic frame-type construction elements.

There are some references of known art in the patent records related to systems that minimize water influent damage from wind storms but, once again, none of these examples lend themselves to our do-it-yourself culture and do not lend themselves to be cost effective for the mass consumption public at large. In addition, none of the known examples provide any strengthening enhancements to improve the structural integrity of frame-type construction to resist the destructive torsion forces imposed by wind storms or the destructive seismic forces imposed by wind storms and other seismic events. Furthermore, none of these prior art sealing systems provides a secondary sealing system in the event that the primary sealing system is compromised.

SUMMARY

This section provides a general summary of the disclosure, and is not a comprehensive disclosure of its full scope or all of its features.

The subject invention overcomes well-known problems in such a way that those skilled in the art will readily recognize and appreciate. Furthermore, the present disclosure provides features and capabilities for many other applications beyond the preferred embodiments disclosed, which those skilled in the art will readily recognize also embody the spirit of the subject invention.

One preferred embodiment of the subject invention relates to a typical residential stick-built or prefabricated home construction which is enhanced and substantially strengthened in specific areas of the structure to better withstand the destructive wind forces of hurricanes and tornados, as imposed in the form of straight line winds, torsion forces, and/or seismic forces. One preferred embodiment also provides a secondary watertight seal which is utilized to maintain a reasonable barrier from influent storm water and blowing rain in the event that the primary water barrier via the shingles and/or siding is compromised during the storm.

It is understood that the secondary water seal requires that the structure must maintain a reasonable structural integrity; therefore, a series of structural enhancements are employed for this purpose and to further maintain structural integrity against storm wind forces. The structural enhancement system is comprised of several subsystems which all work

3

together to collectively enhance the structural integrity of the structure. These subsystems include but are not limited to the following:

- Anchoring System
- Wall Reinforcement System
- Rafter/Joist Tie-Down System
- Wind-Beam System
- Diaphragm Reinforcement System
- Wall Sheeting System
- Roof Decking System
- Venting System
- Window/Door Protective Seal System
- Safe Room System

Those skilled in the art will readily understand that while many typical structures will require all of the listed subsystems to enhance the structure adequately against severe storm winds, some complex structures may require additional specialized subsystems, while less complex structures may only require a partial list of the subsystems. A brief description of each subsystem follows.

Further areas of applicability will become apparent from the description provided herein. The description and specific examples in this summary are intended for purposes of illustration only and are not intended to limit the scope of the present disclosure.

DRAWINGS

The drawings described herein are for illustrative purposes only of selected embodiments and not all possible implementations, and are not intended to limit the scope of the present disclosure.

FIG. 1 is a front left perspective view of a building structure anchoring system;

FIG. 2 is a front left perspective view of the building structure of FIG. 1, further including a wall reinforcement system;

FIG. 3 is a front left perspective view of area 3 of FIG. 2;

FIG. 4 is a front left perspective view of a portion of the building structure of FIG. 1, modified to show upper and lower structure joined by floor joists;

FIG. 5 is a front right perspective view of area 5 of FIG. 3;

FIG. 6 is a bottom front perspective view of a truss assembly;

FIG. 7 is a front left perspective view of the building structure similar to FIG. 2, further including a wall sheeting system;

FIG. 8 is a front left perspective view of a roof decking system;

FIG. 9 is a front elevational view of the roof decking system of FIG. 8;

FIG. 10 is a cross sectional end elevational view taken at section 10 of FIG. 9;

FIG. 11 is a cross sectional end elevational view modified from FIG. 10 to show a venting system;

FIG. 12 is a front elevational schematic view of a building window/door protective seal system;

FIG. 13 is a front left perspective view of the building of FIG. 12 modified to include an interior storm safe room;

FIG. 14 is a front left perspective view of a blocking brace subassembly used to establish a line of compression blocking in a roof system or wall system;

FIG. 15 is a front left perspective view of a line of compression blocking having multiple blocking brace subassemblies of FIG. 14;

4

FIG. 16 is a front elevational perspective view of a line of compression blocking applied to a wall system comprised of blocking brace subassemblies similar to FIG. 14;

FIG. 17 is a top perspective view of a gable-end of a roof system braced against a ceiling joist and roof system construction elements;

FIG. 18 is a an end elevational perspective view of an improved diaphragm system;

FIG. 19 is a side elevational perspective view of an inside corner of a wall system featuring a lateral corner brace enhancement assembly;

FIG. 20 is a side elevational perspective view looking from the outside in through a corner of a wall construction having a lateral corner brace enhancement assembly and a diaphragm system applied to the roof system; and

FIG. 21 is a front elevational view of lateral corner brace enhancement subassembly.

Corresponding reference numerals indicate corresponding parts throughout the several views of the drawings.

DETAILED DESCRIPTION

Example embodiments will now be described more fully with reference to the accompanying drawings.

Referring to FIG. 1, an anchoring system 10 connected to a typical slab 12 defining a foundation construction includes anchor bolt sets 14 at least partially embedded in the slab 12 connected to a wall reinforcement system having multiple anchor brackets 16, and multiple specialized structural members or structural columns 18 connected to the anchor brackets 16. The anchoring system 10 as defined by the subject invention is a subsystem that anchors a building structure 20 to the slab 12 or other foundational elements. One preferred embodiment enhancement system provides specialized first and second anchor bolts 22, 24 to provide proper placement and anchoring means to cooperate with other structural enhancement components. An alternative preferred embodiment employs standard anchor bolt components. Whether using specialized anchor bolts 22, 24 or standard anchor bolts, the present disclosure requires that appropriate anchor means include anchor bolt nuts 26, 28 connecting to freely extending portions 22a, 24a of the specialized anchor bolts 22, 24 to the anchor brackets 16, which are positioned between sequentially spaced apart members such as studs 30, 32, are employed with new construction slabs 12 being poured, preexisting slabs, and for construction or retrofit of structures on top of crawl space walls or basement walls. The freely extending portions 22a, 24a of the anchor bolts 22, 24 for each anchor bracket 16 are oppositely positioned with respect to a longitudinal axis 27 of the structural column 18 connected to each anchor bracket 16 to resist axial rotation/twisting of the structural columns 18 and thereby to resist axial rotation/twisting of the studs 30, 32. The present disclosure unitizes the anchoring system 10 to cooperate and integrate the respective features of a wall reinforcement system 34 (shown and described in reference to FIGS. 2-3) and/or a safe room system 72 (shown and described in reference to FIG. 13).

Referring to FIG. 2 and again to FIG. 1, the wall reinforcement system 34 as defined by the present disclosure is a subsystem which integrates into a typical stud type wall construction 36 of building structure 20 to provide significant enhanced compression and tension strength to the wall construction 36. A typical wood or metal stud built wall 38 having sequentially spaced studs 30, 32 may have appropriate compressive strength but it has very little tension strength and therefore is susceptible to lift forces during storm winds. In

5

addition, the wall reinforcement system **34** of the subject invention provides resistance to forces that result in torsion and/or rhombus conditions. The specialized structural member or structural column **18** is a metal tube installed in the stud wall **38** at intervals between adjacent ones of the studs along the wall **38** and/or at wall corners **40** such that the structural member **18** is substantially stronger than the typical stud wall components, such as wood or metal studs, and is capable of being firmly and strongly attached to the anchoring system **10** described in reference to FIG. 1. According to one embodiment, sheeting **42** is bolted to the specialized wall member **18** which is anchored to the foundation slab **12** and bolted through a double top plate **44** to the rafter/joist tie-down system **46**. The wall reinforcement system **34** provides a strong and solid connection from a bottom plate **48** of the stud wall **38** all the way to the top plate **44** of the stud wall **38**, where it is again firmly and solidly attached and terminated.

Referring to FIG. 3 and again to FIGS. 1-2, according to one embodiment, the structural column **18** is bolted through the top plate **44** of the wall **38** to roof elements **50**, **52**, such as the upper and lower chords of a roof truss or the rafters and ceiling joists of a common roof system. The wall reinforcement system **34** ties together the roof components, the wall components, and the foundation using the structural columns **18** fastened/bolted at opposite ends to building structure.

Referring to FIG. 4 and again to FIGS. 1-3, the present disclosure also applies to multi-story structures by employing bolted connections across a floor joist construction **54** of a multi-story wall construction **56** wherein wall reinforcement columns **18**, **18'** on lower and upper floors **58**, **60** are bridged and connected via bolted connectors **62**, **64** across the floor joist construction **54**. The present disclosure effectively unitizes the entire wall construction **56** by employing the wall reinforcement system **34** to cooperate and integrate the respective features of the anchoring system **10** and a rafter/joist tie-down system **66** (which is shown and described in reference to FIG. 5) and with a wall sheeting system **68** (which is shown and described in reference to FIG. 7) and with a diaphragm reinforcement system **70** (which is shown and described in reference to FIG. 10) and/or a safe room system **72** (which is shown and described in reference to FIG. 13).

Referring to FIG. 5 and again to FIGS. 1-4, the rafter/joist tie-down system **66** as defined by the subject invention is a firmly and strongly attached means to effectively connect the upper chords or rafters **50** and the lower chords or ceiling joists **52** to the top plate **44** of the stud wall **38** and more importantly directly to the wall reinforcement system **34**. The rafter/joist tie-down system **66** also provides a strong connection means at each crossing point on outside walls and inside walls for every rafter **50** and/or joist **52** whether it is connected directly to or indirectly connected to a member **18** of the wall reinforcement system **34**.

Referring to FIG. 5, each wall reinforcement member or structural column **18** is bolted to a rafter tie-down connector **74**. A typical truss example is provided wherein a rafter tie-down extension **76** spans between the lower chord **52** and upper chord **50** of a truss **78**. The rafter/joist tie-down system **66** also resists rafters **50** and/or joists **52** from being compromised due to lift forces generated by storm wind forces. The rafter/joist tie-down system **66** also resists rafters **50** and/or joists **52** from being easily twisted due to torsion forces and/or rhombus forces, which enhances the relative strength of the structure to resist shear forces acting upon the structure as a result of strong straight line winds or tornadic vortexes. Testing and research has demonstrated and taught that the best roof pitch for storm wind resistance is about a 15-degree

6

angle off a horizontal plane; that a hip roof construction is more storm-worthy than a gable end construction; and further that less roof overhang is better than long extended roof overhang construction.

The present disclosure and rafter/joist tie-down system **66** is able to enhance standard roof construction that exploits the known research and yet still provides some enhancements for other roof constructions that do not conform to the prior art research for best storm construction. The subject invention effectively unitizes the entire roof system by employing the features of the rafter/joist tie-down system **66** to cooperate and integrate with the respective features of the wall reinforcement system **34** and a wind-beam system **80** (shown and described in reference to FIG. 6), a roof decking system **82** (shown and described in reference to FIG. 8), a venting system **84** (shown and described in reference to FIG. 11), the diaphragm reinforcement system **70**, and/or the safe room system **72**.

Referring to FIG. 6, the wind-beam system **80** as defined by the subject invention is a series of reinforcement components employed at the connections of rafters **50**, **50'** and trusses **52** to enhance the structural integrity of the rafters and trusses. A typical truss **52** is enhanced at connection points **86**, **88**, **90** with wind-beam components including in several preferred embodiments a wind-beam chord connector **92**, a wind-beam extension **94**, and a wind-beam ridge connector **96**. The wind-beam chord connector **92** is a metal member connecting the joist **52** to an angularly oriented joining member, which according to several aspects is a transversely oriented center gable end stud or kingpost **100**. The wind-beam ridge connector **96** is a metal plate connecting the kingpost **100** to both the upper chords or rafters **50**, **50'**. The wind-beam extension **94** is a metal U-channel that can be used to connect the wind-beam chord connector **92** to the wind-beam ridge connector **96**. Typical construction techniques for rafters **50** and trusses **52** include nail plates and individual nails at connection points. During storm wind conditions, one side of the roof is considered the windward side if the wind is blowing directly toward that roof section. As a result, the forces acting upon the roof place it in compression. In contrast, the opposite side of the roof is referred to the leeward side and creates lifting force acting on this portion of the roof. As a result, the combination of one side of the roof pressing down simultaneously as the other side is trying to lift off invites significant structural damage at relatively low force values.

The wind-beam system **80** effectively reinforces roof rafters **52** and/or trusses **98** together with strong and securely fastened members such as the wind-beam chord connector **92**, wind-beam extension **94**, and wind-beam ridge connector **96**, which effectively unitizes the entire roof system together to act more as a unit than as individual roof components. The wind-beam system **80** works on traditional rafter systems and/or traditional truss systems. Those skilled in the art will appreciate that the steeper the roof pitch, the greater the lift forces on the leeward side, and thus the stronger the wind-beam system **80** effectively needs to be, all things being equal. The subject invention effectively unitizes the entire roof system by employing the features of the wind-beam system **80** to cooperate and integrate with the respective features of the rafter/joist tie-down system **66** and the roof decking system **82**, the venting system **84**, the diaphragm reinforcement system **70**, and/or the safe room system **72**.

Referring to FIG. 7 and again to FIGS. 1-6, the wall sheeting system **68** as defined by the subject invention provides an improved method of covering and sealing the exterior walls **38** of the structure prior to applying additional façade or other cosmetic coverings such as vinyl siding, brick, et cetera. Wall

sheeting **42**, such as plywood, is bolted to the wall reinforcement structural columns **18** using bolts **102**. The wall sheeting system **68** provides an improved fastening method by bolting the sheeting **42** to the wall reinforcement system **34**, which ensures that the sheeting **42** will remain securely in place when the structure is exposed to storm wind forces. Because the wall sheeting system **68** stays securely in place during storm wind forces, it is enabled to provide a secondary water seal for the wall **38** to resist rain and blowing rain in the event that the primary covering and weather seal façade is compromised and/or lost during storm winds subjected upon the structure. One preferred embodiment of the subject invention includes a specialized bolted fastener **102** featuring an enlarged flat head **104** with barbs **106** which seat into the sheeting **42** and includes a sealing ring rib **108** on the underside **110** of the enlarged head **104** to securely and firmly hold and maintain a watertight seal. In appropriate applications, the wall sheeting system **68** is incorporated into the safe room system **72** such that requirements for resisting penetrations from airborne debris are accomplished. The subject invention effectively unitizes the entire wall construction by employing the features of the wall sheeting system **68** to cooperate and integrate with the respective features of the wall reinforcement system **34** and a window/door protective seal system **112** (shown and described with respect to FIG. **12**), and the safe room system **72**.

Referring to FIG. **8** and again to FIGS. **1-3**, the roof decking system **82** as defined by the subject invention provides an improved method of covering and sealing roof decking **114** such as sheets of plywood of the structure prior to applying additional façade or other cosmetic coverings such as shingles, metal, et cetera. A watertight tape seal **116** applied over seams **118** at mating edges of roof decking **114** helps to provide a watertight seal. The roof decking system **82** provides an improved fastening means via nails and/or screws and/or a specific patterned array application of the fasteners so as to securely retain the decking **114** attached to the rafters and/or joist structure.

Referring to FIG. **9** and again to FIGS. **1-3** and **8**, according to one preferred embodiment of the subject invention, a specialized fastener **120** has a relatively large head and specialized retention features so as to provide improved retention of the decking to the rafters and/or joist. Another preferred embodiment of the subject invention features the decking **114** to be tongue & grooved so as to provide a watertight seal via interlaced edges of the decking. A further preferred embodiment of the decking **114** features a shiplap edge **122** which presents a watertight sealed edge on a bias cut. Yet another preferred embodiment of the decking includes lineup blocking **124** between adjacent rafters **50, 50'** and located under the edges **126** of adjacent decking **114** so as to provide a secure fastening surface for the entire edge **126** of the decking **114**. The lineup blocking **124** also provides an effective sealing surface under the edge of adjacent sheets of decking **114** and prevents relative deflection at the mating edges of adjacent sheets of decking. The lineup blocking **124** also provides proper alignment and spacing between rafters **50, 50'** while at the same time providing resistance to torsion and rhombus forces acting on the rafters and joist. The lineup blocking **124** also defines a continuous line of compression blocks installed between juxtaposed rafters and/or joist to prevent lateral collapse of the structure.

One preferred embodiment of the lineup blocking **124** features a bracket **128** which can be either preassembled to the ends of the lineup block **124** or installed after the lineup block **124** is installed. The bracket **128** provides additional ease of assembly and additional structural integrity to the

rafters **50** and decking **114**. Another preferred application of the subject invention employs the respective features of a watertight membrane **130** placed over the decking **114** and/or the watertight seal tape **116** covering over the mating edges of adjacent sheets of decking **114**, including ridges and valleys.

Referring to FIG. **9** and again to FIGS. **1-8**, a cross section through one preferred embodiment of the roof decking system **82** shows shiplap edges, lineup blocks **124**, lineup block brackets **128**, decking fasteners **120**, tape-seals **116** at joints, and the watertight membrane **130**. The roof decking system **82** provides a secondary water seal for the roof to resist rain and blowing rain in the event that the primary covering and weather seal façade is compromised and/or lost during storm winds subjected upon the structure. The subject invention effectively unitizes the entire roof construction by employing the roof decking system **82** to cooperate and integrate with the respective features of the wall reinforcement system **34**, the wind beam system **80**, the rafter/joist tie-down system **66**, the roof decking system **82**, the venting system **84**, the diaphragm reinforcement system **70**, and/or the safe room system **72**.

Referring to FIG. **10**, the diaphragm reinforcement system **70** as defined by the subject invention addresses several diaphragm problems commonly associated with residential and commercial construction. One common diaphragm problem is gable ends of construction wherein, for instance, a triangle shaped wall gable end **132** is formed enclosing one end of a roof system **134**. The gable end **132** forms a gable end plane **136** inside the triangle frame of the gable end **132** which is susceptible to being either blown in or sucked out in response to storm winds. Another common diaphragm problem is a joist plane **138** formed by any one of several rafter/joist/truss components, such as joists **52** shown, juxtaposed in array adjacent to the gable end **132** of the roof construction. The joist plane **138** is susceptible to being warped and/or wrenched and/or twisted and/or laterally shifted in response to storm wind forces. Yet another common diaphragm problem is a ceiling plane **140** formed by a ceiling **142** on the underside of the juxtaposed array of joists **52**. The ceiling plane **140** is susceptible to warping and flexing due to the joist plane **138** responding to storm winds acting on the structure.

The subject invention overcomes the problems associated with these diaphragms by employing the diaphragm reinforcement system **70**. One preferred embodiment of the diaphragm reinforcement system **70** features a pearling brace **144** spanning transverse across the gable end **132**. The pearling brace **144** in one preferred embodiment provides a series of specialized brackets **146** which cooperate with standard wood components to enhance the structural integrity of the gable end plane **136**. In another preferred pearling embodiment, a structural metal beam **148** and associated brackets span transversely across the gable end **132** to enhance the structural integrity of the gable end plane **136**. Another preferred embodiment of the diaphragm reinforcement system **70** features a series of joist brace elements **150** spanning transversely across the array of juxtaposed joists **52** so as to enhance the structural integrity of the joist array to prevent them from being negatively affected by storm force winds.

The joist brace elements **150** are firmly affixed to the joist **52** such that the joist **52** is not only prevented from suffering detrimental joist plane **138** deformation but also preventing detrimental ceiling plane **140** deformation. The joist brace elements **150** are firmly anchored to specialized gable end brackets **152** at the gable end **132** which in turn are directly anchored to the wall reinforcement system **34** components, which in turn anchor the entire construction to the foundation elements. The joist brace elements **150** also include strut elements **154** attaching at one end to the joist brace elements

150 and then spanning at a bias angle α up to a connection point **156** on the pearling brace **144**. The strut **154** forms the hypotenuse of a triangle comprised of the strut **154**, the gable end plane **136**, and a joist brace **158** element, which subsequently forms an enhanced structural means to impart structural integrity to the diaphragms aforementioned which were previously unattainable prior to the subject invention. One or more joist brace brackets **160** which connect the joist brace **158** to the joists **52** also define members of the joist brace elements **150**.

With continuing reference to FIG. **10**, the gable end plane **136**, the ceiling plane **140**, and the joist plane **138** are simultaneously structurally enhanced via the collective features of the gable end bracket **152**, the joist brace bracket **160**, the joist brace **158**, the strut **154**, and the pearling brace **144**. As a result, the entire set of diaphragms are effectively unitized together and integrated into a larger unitized system of structural integrity to maintain a watertight seal system for the construction when subjected to storm wind forces. The subject invention effectively unitizes the diaphragm reinforcement system **70** by employing and integrating the respective features of the anchoring system **10**, the wall reinforcement system **34**, the rafter/joist tie-down system **66**, the wind-beam system **80**, the wall sheeting system **68**, the venting system **84**, and/or the safe room system **72**.

Referring to FIG. **11**, according to one preferred embodiment of the venting system **84**, an internal access vent **162** enables air to pass from the conditioned air space defining a living portion **164** of the structure and slightly conditions the air in a roof space **166**, wherein a closed cell spray foam **168** insulates and seals the entire underside of a roof system **170** and gable ends **132** to prevent water leaks. The venting system **84** as defined by the subject invention provides a solution for maintaining appropriate thermal conditions for the air in the roof space **166** of a structure so that appropriate air changes and/or conditioning occur in the roof space **166**. Typical venting methods include a series of external access vents, such as under eave soffit vents, gable vents, ridge vents, turbines, and louvers, many of which come in passive or powered variations.

A significant problem that basically all known external access venting systems suffer is that they are susceptible to being damaged and/or completely removed during blowing rain in wind storm conditions, which lead to water leaks and subsequent damage. Another significant problem that basically all prior art external access venting systems suffer is that, even if they manage to stay intact during the wind storm conditions, they are further susceptible to allowing blowing rain in wind storm conditions to pass through them and into the roof space, which leads to water leaks and subsequent damage. Therefore, one preferred embodiment of the venting system **84** of the subject invention provides specialized external venting devices for influent and effluent air handling which are able to remain firmly and functionally intact and at the same time control and mitigate blowing rain during wind storm conditions such that water is channeled and/or redirected and/or drained back out of the structure, preventing damaging accumulation inside the structure.

Another preferred embodiment of the subject invention eliminates all external access vents so as to eliminate the problems with any such locations and/or associated venting devices, and replaces them with the small, appropriately sized internal access vents **162** directly connecting the conditioned portion of the structure to the roof space to slightly "condition" the air in the roof space. There is, therefore, no external access vents communicating between the internal conditioned portion of the building structure to ambient air outside

the building structure. The conditioned air in the roof space **166** is both appropriately cooled and/or heated in conjunction with the seasons of the year to maintain a moderate temperature range in the roof space **166**. The conditioned air in the roof space **166** is further enabled by having no influent or effluent outside air to influence the roof space **166**; however, an efficient insulation sealing system, such as the closed cell spray foam **168**, is applied to the entire underside of the roof construction to fill in between the rafters **50** to provide an air and water seal to prevent air and water from penetrating the roof construction into the roof space **166**. The closed cell spray foam **168** insulation also covers and seals any fasteners of the decking **114** or shingles **172** or other exterior construction that might have penetrated through the decking **114** and into the roof space **166**, such that any chance of becoming a future leak path is prevented. The closed cell spray foam **168** insulation also covers walls **174** of the gable ends **132** in the same manner. The subject invention effectively cooperates with a unitized roof construction by employing the venting system **84** to cooperate and integrate with the respective features of the roof decking system **82**, the wind beam system **80**, the rafter/joist tie-down system **66**, and the diaphragm reinforcement system **70**.

Referring to FIG. **12**, one preferred embodiment of the window/door protective system **112** provides for a typical widow **176** for residential structures which is fitted with installed decorative cover mounts **178** such that a removable protective cover **180** securely fastens to the cover mounts **178**. The window/door protective system **112** as defined by the subject invention provides the protective cover **180** over windows **176** to minimize the likelihood of breakage during wind storms. One preferred embodiment of the window/door protective system **112** is comprised of a series of brackets **182** and mounting hardware designed to securely establish a robust attachment to the structure **184** and receives an appropriate protective cover **180** designed to fit into and cooperate with the mounted protective cover brackets **182**. The protective covers **180** can be stored until required to prepare for an oncoming wind storm. The mounted brackets **182** will remain mounted to the structure **184** and designed to be reasonably decorative. Another preferred embodiment of the subject invention features a similar protective cover **186** over doors **188** and/or installed inside of exterior doors to prevent them from blowing in or being sucked outward during storm winds. Another preferred embodiment of the subject invention features a protective cover over garage doors (not shown) to prevent them from blowing in or being sucked outward during storm winds. The subject invention employs the window/door protective system **112** to cooperate and integrate with the respective features of the wall reinforcement system **34** and/or the safe room system **72**.

Referring to FIG. **13**, a preferred embodiment of the storm safe room **72** provides an independent unitized room **190** constructed and fitted with a storm door **192** and an air vent **194** positioned inside the building structure. Another preferred embodiment of the subject invention features a storm safe room system **72** which is prefabricated from appropriate enhanced components and delivered to the construction site, and then installed so the building **196** can be constructed around it. The storm safe room system **72** as defined by the subject invention provides enhanced construction components for a self-contained storm safe room which is firmly and strongly anchored to the foundation and/or slab of the structure. The enhanced construction components include those featured in the wall reinforcement system **34**, the anchor system **10**, the rafter-joist tie-down system **66**, the wind beam system **80**, door/window protective seal system **112**, and/or

11

the roof decking system **82**, all combined together to establish a unitized structure to function as an appropriate storm safe room system **72**.

Another preferred embodiment of the storm safe room system **72** includes an independent unitized roof **198**, reinforced walls **200**, and the storm door **192** which opens inward. The door features enhanced hinges **202** and locking and security components **204** to ensure closure in the event it is subjected to storm force winds, flying debris, and/or influent water. The storm safe room system **72** provides the independent fresh air vent **194** and the reinforced door **192** to prevent it from opening except at the command of the occupant and provides a watertight seal **206** to prevent influent water. The storm safe room system **72** provides a storm room suitable of being used as a dual purpose room, such as a closet, pantry, bathroom, or the like. One preferred embodiment of the subject invention features a storm safe room system **72** constructed on-site using appropriate enhanced components.

The subject invention effectively establishes a unitized storm safe room system **72** by cooperating and integrating with the respective features of the anchor system **10**, the wall reinforcement system **34**, the rafter/joist tie-down system **66**, the window/door protective seal system **112**, the roof decking system **82**, the venting system **84**, the wind-beam system **80**, the diaphragm reinforcement system **70**, and the wall sheeting system **68**.

Referring to FIG. **14**, at least a first blocking brace bracket **207** and according to several aspects first and second blocking brace brackets **207** are connected to a blocking brace **208** to form a blocking brace subassembly "A". Multiple subassemblies "A" are used to establish a line of compression blocking on roof and/or wall systems as best seen in reference to FIG. **15**. Each subassembly "A" is bolted into place to provide improved structural strength effectively unitizing the frame-type construction elements of the roof and/or wall system. The present disclosure incorporates a line of compression blocking in combination with the other structural enhancements to effectively unitize the entire frame-type construction elements of the building to resist the destructive forces associated with wind and/or seismic events.

Referring to FIG. **15** and again to FIG. **14**, a partial view of a line of compression blocking includes multiple subassemblies "A" comprised of blocking braces **208** and blocking brace brackets **207** fastened to roof elements **209**. Two brackets **207** which are installed juxtaposed on either side of a roof element **209** are bolted together through roof element **209** establishing a strong continuous line of compression blocking. Each bracket **207** features fastening holes straddling each side of blocking brace **208** which provide stable resistance to torsion and/or seismic forces imposed upon the roof system.

Referring to FIG. **16** and again to FIGS. **14-15**, a partial view of a line of compression blocking includes multiple subassemblies "B" similar to subassemblies "A" which are comprised of blocking braces **210** and blocking brace brackets **207** fastened to wall elements **211**. Two brackets **207** which are installed juxtaposed on either side of a wall element **211** are bolted together through wall element **211** establishing a strong continuous line of compression blocking. Each bracket **207** features fastening holes straddle each side of the blocking brace **210** which provide stable resistance to torsion and/or seismic forces imposed upon the roof system.

Referring to FIG. **17** a partial view of a typical frame-type building includes a diaphragm enhancement system **220** assembled on a large gable-end truss **212** and braced against vertical studs **219** and joist elements **52**. The diaphragm enhancement system **220** includes at least one horizontal prefabricated brace **213** attached to studs **219** along its length,

12

and attached at each end **218** to truss **212**. Brace **213** and supported by at least one angled prefabricated brace **214**, which is attached to at least one lateral prefabricated brace **215** with double-clevis attachment bracket **216**. When large gable-end truss constructions are installed, they require additional structural enhancement to resist destructive forces, such that at least one and according to several aspects multiple additional horizontal prefabricated braces **213** are provided as necessary which are attached to vertical studs **219**. Horizontal prefabricated braces **213** are supported by at least one additional angled prefabricated brace **214**, which is attached to lateral prefabricated braces **215** using double-clevis attachment brackets **216**.

Lateral brace **215** is fitted with single-clevis attachment brackets **222** positioned to cooperate with joist elements **52** so as to establish and maintain parallel spacing of joist elements **52**. When wind and torsion forces are imposed upon a frame type construction, the joists **52** are susceptible to flexing and shifting out of position. As a result, sheeting such as sheetrock attached to the interior room side of joist **52** can be compromised and damaged. The present disclosure provides improved structural integrity for joists **52** by maintaining parallel position and resisting shifting movement of joists **52** in response to wind and torsion forces, while also preventing a plane of the ceiling from being compromised.

Prefabricated horizontal brace **213** is bolted to vertical studs **219** along its length and bolted at ends **218** to truss **212**. This bolted system effectively unitizes the entire gable-end truss thereby resisting wind and torsion forces imposed upon it, as well as preventing a plane of the gable from being blown in or sucked out. A first angled prefabricated brace **214** is attached to prefabricated lateral brace **215** using a double-clevis bracket **126**. In large gable installations, a second or third bracing system may be required to adequately resist damaging forces. In such installations, a second prefabricated angle brace **214** can be attached to either the prefabricated lateral brace **215** or to a first installed angle brace **214** by using double-clevis attachment bracket **216**. Enhanced diaphragm enhancement system **220** includes a fastening point where prefabricated lateral brace **215** is fastened to bottom chord of truss **212** using a specialized anti-hinge bracket **217**.

Referring to FIG. **18** and again to FIG. **17**, connections of enhanced diaphragm system **220** include joist elements **52** which are spaced parallel and maintain position via single-clevis attachment brackets **222** which fasten joists **52** to prefabricated lateral braces **215**. Double-clevis attachment brackets **216** fasten prefabricated angled braces **214** to prefabricated lateral braces **215**. A second prefabricated angle brace **214** can be fastened to a first angle brace **214** or fastened to lateral brace **215** using double-clevis attachment bracket **216**. Double-clevis attachment bracket **216** is able to slide along lateral brace **215** and/or angled brace **214** so that proper support can be field cut and installed by field drilling appropriate bolting holes in braces **214** or **215**. Attachment holes pre-drilled in double-clevis bracket **216** act as drill guides to save time measuring and locating the position of mounting holes through lateral brace **215** or angled brace **214**.

An anti-hinge bracket **217** is fastened to prefabricated lateral brace **215** and bolted in multiple locations to bottom truss chord **221**. Mounting holes in anti-hinge bracket **217** are positioned straddling lateral brace **215** which provide improved enhancement strength and structural integrity for the gable-end truss to prevent the truss from collapsing and/or being sucked out from wind and/or torsion forces. Additional mounting holes in anti-hinge bracket **217** cooperate and align with anti-torsion tension-compression columns by bolting down through the double top plate **44** with fasteners **236** and

bolting directly to the structural columns **18**, which tie directly to foundational elements. In traditional gable-end truss construction, destructive forces can collapse a gable-end truss by effectively hinging it over where the bottom chord **221** mates with double top plate **44**. The present disclosure overcomes this problem by combining the unitized benefits and support of enhanced diaphragm system **220** which includes at least one anti-hinge bracket **217**.

Referring to FIG. **19** an inside corner of a typical frame-type construction includes a corner **224** positioned between two intersecting walls comprised of multiple studs **30**, **32**, a bottom plate **48**, and a double top plate **44**. A lateral corner brace subassembly **223** is installed on each side of corner **224** and fastened to studs **30**, **32**, fastened down through bottom plate **48** to foundation anchors, fastened up through the double top plate **44** to roof elements, and fastened to corner **224**. This configuration effectively unitizes the entire corner portion of the building to resist damaging wind and torsion forces imposed by storms and seismic events. The present disclosure provides enhanced structural integrity throughout the entire structure by combining the features and benefits of many structural improvements such as lateral corner brace subassemblies **223**.

Lateral corner brace subassemblies **223** are appropriately installed straddling building corners as shown in FIG. **19** wherein two subassemblies **223** are used. Installations where an interior wall intersects an exterior wall may require three subassemblies **223**, wherein two of the subassemblies **223** will be oriented along the exterior wall straddling the intersecting corner, and one subassembly will be oriented transverse along the interior wall. All three of the subassemblies **223** will be fastened to the intersecting corner, which will provide substantially enhanced structural integrity to the building to resist damaging winds and/or torsion forces imposed by storm and/or seismic events.

Referring to FIG. **20** and again to FIGS. **17-19**, a typical frame-type construction has a corner **224** installed with two lateral corner brace subassemblies **223** oriented along each of the intersecting walls joined at corner **224**. Gable-end truss **212** is installed with a bottom chord **221** connected to the double top plate **44** of the wall construction. Wall sheeting **225** is fastened to studs **30**, **32** in the wall construction. Prefabricated trusses **234** are installed in a line juxtaposed next to gable-end truss **212**. The present disclosure improves the structural integrity of wall sheeting by providing fastening points between the wall sheeting and subassemblies **223**. The present disclosure further enhances the gable-end truss **212** by providing a bolted connection from subassembly **223** up through the double top plate **44** of the wall to connect to anti-hinge bracket **217** (not shown) which is bolted to bottom truss chord **221**, and bolted to the diaphragm enhancement system **220**. A line of compression blocking (as shown in FIG. **15**) is installed in trusses **234**. Subassemblies **223** are bolted to the corner **224**, bolted to the roof elements which are bolted to the trusses **234**, bolted to the diaphragm enhancement system **220**, fastened to the wall sheeting, bolted through the double top plate **44**, bolted through the bottom plate **48**, and directly anchored to foundational elements, effectively unitizing all of the frame-type construction elements with structural integrity.

Referring to FIG. **21** and again to FIGS. **17-20** each subassembly **223** can comprise at least two specialized anti-torsion tension compression structural columns **18**, at least one lateral connecting brace **232**, and at least one corner connecting bracket **235**. Lateral connecting brace **232** is comprised of a lateral spanner beam **233** assembled between two lateral connecting brackets **227**. Lateral spanner beam **233** is

predrilled with holes to provide fastening points for wall sheeting. Structural columns **18** are predrilled with fastening holes **228** spaced along the length of the structural column **18** for fastening wall sheeting. Structural columns **18** are also predrilled with holes to assemble lateral connecting brackets **227** and to receive corner connecting brackets **235**. The lower end of structural columns **18** are fitted with connecting brackets **230** allowing bolted connections down through the bottom plate **48** to fasten directly to foundational elements. The upper end of structural columns **18** are fitted with connecting brackets **231** to bolt through the double top plate **44** and connect to roof elements.

The present disclosure significantly enhances the structural integrity of a framed construction with the installation of subassemblies **223** at each corner and the diaphragm enhancement assembly **220**. In addition to these enhancements, the present disclosure includes the integration and benefits of the anchoring system (not shown) and the line of compression blocking (described in reference to FIGS. **15** and **16**) and anti-torsion roof system elements and anti-torsion tension compression columns, all combined together to provide a unitized structural frame-type building capable of resisting substantial wind forces, torsion forces, and/or seismic forces, well above what is possible before the introduction of the subject invention.

The present disclosure further incorporates the benefits of a secondary sealing system to maintain an integral seal in the event that exterior cosmetic and primary sealing systems are compromised during storm events.

The present disclosure further incorporates the features of an entire unitized structural enhancement system to combine with a unitized safe-room to provide maximum protection from the storm events.

The present disclosure provides an improved system for a typical residential or commercial structure wherein a series of specialized components are integrated together so as to enhance the structural integrity of the structure against wind forces, such as those associated with hurricanes and/or tornados, so as to provide a secondary relatively watertight seal for the structure, even in the event that the primary sealing system of shingles and/or siding is compromised, damaged, or removed by the storm winds. As a result, known shingles and siding provide a cosmetic covering and a primary water seal for the structure; however, the present disclosure provides a secondary water seal in the event that the primary seal system is compromised during storm wind exposure.

The present disclosure further provides structural enhancements that can be applied to new construction as well as retrofitting existing structures so as to improve structural integrity and secondary sealing against wind and seismic forces such as those associated with hurricanes and/or tornados. The present disclosure further provides structural enhancements that cooperate with standard construction components so as to improve the structural integrity of the construction components beyond their original capabilities against wind and seismic forces, such as those associated with hurricanes and/or tornados, and further to provide a secondary sealing system to resist influent water in the event that the primary sealing system is compromised.

The typical preferred embodiment construction material for the structural enhanced components of the subject invention is metal. Said components may be manufactured from metal using any one of several typical methods such as stamping, forging, bending, welding, or combinations of fabrication methods. In addition, said components may be manufactured from non-metal materials such as plastic, reinforced

plastic, fiberglass, composites, and/or any other appropriate technology materials suitable to provide the strength requirements for a given application.

The foregoing description of the embodiments has been provided for purposes of illustration and description. It is not intended to be exhaustive or to limit the disclosure. Individual elements or features of a particular embodiment are generally not limited to that particular embodiment, but, where applicable, are interchangeable and can be used in a selected embodiment, even if not specifically shown or described. The same may also be varied in many ways. Such variations are not to be regarded as a departure from the disclosure, and all such modifications are intended to be included within the scope of the disclosure.

What is claimed is:

1. A construction system providing structural integrity for a building structure to resist the destructive forces of storm winds, torsion forces, and seismic forces, and to minimize or prevent the influent of associated wind-driven blowing rain, comprising:

multiple subsystems connected to the building structure, the building structure including a wall structure having multiple studs and a roof structure including at least one from a group of trusses, joists and rafters, the multiple subsystems including:

an anchoring system connected to a foundation;

a wall reinforcement system having multiple structural columns individually positioned between proximate ones of the studs;

a lateral corner brace reinforcement system having sub-assemblies positioned along intersecting walls and fastened together at a building structure intersecting corner;

a diaphragm reinforcement system having multiple members fastened to gable-ends of the roof structure, fastened to at least one from the group of trusses, joists and rafters of the building structure, and connected to the anchoring system;

a line of compression blocking in the building structure; a rafter/joist tie-down system having multiple members individually coupling each of the structural columns to the roof structure such that the wall reinforcement system ties together the roof structure and the wall structure to the foundation using the structural columns; and

the diaphragm reinforcement system including at least one horizontal support beam fastened across one of the gable-ends of the roof structure, the diaphragm reinforcement system being supported by at least one angled brace connected to at least one lateral brace fastened to at least one from the group of trusses, joists and rafters, and the diaphragm reinforcement system including an anti-hinge bracket fastened to at least one of the structural columns and to a foundational element of the anchoring system.

2. The construction system of claim **1**, wherein the subsystems further include a line of compression blocking in the roof structure having aligned bolted connections straddling individual blocking braces.

3. The construction system of claim **2**, wherein a roof decking is fastened to the blocking braces.

4. The construction system of claim **1**, wherein the subsystems further include a line of compression blocking in the wall system having aligned bolted connections straddling multiple individual blocking braces.

5. The construction system of claim **4**, wherein a wall sheeting is fastened to the blocking braces.

6. The construction system of claim **1**, wherein the at least one angled brace is attached to at least one lateral brace using a double-clevis bracket.

7. The construction system of claim **6**, wherein the double-clevis bracket includes a predrilled hole providing a drill guide for field installation and attachment.

8. The construction system of claim **1**, wherein the lateral brace is attached to a joist using a single-clevis bracket.

9. The construction system of claim **1**, wherein the anti-hinge bracket includes mounting holes for attachment to a gable-end construction positioned straddling a lateral brace and fastened to the anti-hinge bracket.

10. The construction system of claim **1**, wherein the anti-hinge bracket is fastened directly to the gable-end, fastened directly to a double top plate of the wall structure, and fastened directly to the lateral brace of the diaphragm reinforcement system, and further connected to a foundation element of the anchoring system through a structural column in the wall construction.

11. The construction system of claim **1**, wherein the subsystems further include a lateral corner brace reinforcement assembly including at least one structural column, at least one lateral spanning beam, and at least one corner connecting bracket.

12. The construction system of claim **11**, further including multiple structural columns individually predrilled as fastening points for a wall sheeting.

13. The construction system of claim **11**, further including multiple lateral beams individually predrilled as fastening points for a wall sheeting.

14. The construction system of claim **11**, wherein the lateral corner brace reinforcement assembly includes at least one corner connecting bracket predrilled to fasten to a corner construction element.

15. The construction system of claim **11**, wherein the lateral corner brace reinforcement assembly is fastened directly to multiple corner construction elements, fastened directly to a roof reinforcement element through a double top plate, connected to a foundational element, and fastened directly to a wall sheeting.

16. The construction system of claim **15**, wherein the lateral corner brace reinforcement assembly is also fastened to the diaphragm reinforcement system.

17. The construction system of claim **1**, wherein the anchoring system includes anchor fasteners connected to and partially extending from the foundation, each structural column connected to two of the anchor fasteners.

18. A construction system providing structural integrity for a building structure

including a wall structure having multiple studs, a foundation, and a roof structure including gabled ends and at least one from a group of trusses, joists and rafters, the construction system comprising:

an anchoring system including a foundational element that is connected to the foundation of the building structure;

a wall reinforcement system having multiple structural columns individually positioned between proximate ones of the multiple studs of the building structure; and

a diaphragm reinforcement system that is substantially transverse to at least one from the group of trusses, joists and rafters, the diaphragm reinforcement system having multiple members fastened to at least one of the gable-ends of the roof structure, at least one from the group of trusses, joists and rafters of the building structure, and the anchoring system;

17

wherein the diaphragm reinforcement system includes
 at least one horizontal support beam fastened to at
 least one of the gabled-ends of the roof structure, the
 diaphragm reinforcement system being supported by
 at least one angled brace connected to at least one 5
 lateral brace fastened to at least one from the group of
 trusses, joists and rafters, the diaphragm reinforce-
 ment system including an anti-hinge bracket fastened
 to the at least one of the gabled-ends of the roof
 structure and to at least one structural column of the 10
 multiple structural columns such that the anti-hinge
 bracket directly ties the diaphragm reinforcement
 system and the at least one of the gabled-ends of the
 roof structure to the foundational element of the
 anchoring system via the at least one structural col- 15
 umn.

19. The construction system of claim **18**, wherein
 the foundational element of the anchoring system includes
 anchor fasteners that are connected to and partially
 extend from the foundation and 20
 wherein each structural column of the multiple structural
 columns is connected to two of the anchor fasteners.

* * * * *

18