



US008911384B2

(12) **United States Patent**
Santiago

(10) **Patent No.:** **US 8,911,384 B2**
(45) **Date of Patent:** **Dec. 16, 2014**

(54) **WOUND MEASURING DEVICE AND SYSTEM**

(76) Inventor: **Carmen Celia Santiago**, Southlake, TX (US)

(*) Notice: Subject to any disclaimer, the term of this patent is extended or adjusted under 35 U.S.C. 154(b) by 0 days.

(21) Appl. No.: **13/475,170**

(22) Filed: **May 18, 2012**

(65) **Prior Publication Data**

US 2012/0302923 A1 Nov. 29, 2012

Related U.S. Application Data

(60) Provisional application No. 61/489,391, filed on May 24, 2011.

(51) **Int. Cl.**

A61B 5/103 (2006.01)
A61B 5/107 (2006.01)
A61B 5/11 (2006.01)

(52) **U.S. Cl.**

CPC **A61B 5/1072** (2013.01); **A61B 5/1109** (2013.01)
USPC **600/587**; 33/512

(58) **Field of Classification Search**

CPC A61B 5/4528; A61B 5/103; A61B 5/0053
USPC 600/595, 587; 33/430, 465, 472, 473
See application file for complete search history.

(56) **References Cited**

U.S. PATENT DOCUMENTS

1,065,046 A * 6/1913 Higgins 33/472
1,367,612 A * 2/1921 McKinney 33/472
1,545,424 A 7/1925 Heimrich
2,664,768 A * 1/1954 Clyne 408/241 R
4,483,075 A * 11/1984 Kundin 331/21
4,525,933 A 7/1985 Patterson

4,641,436 A * 2/1987 Tzen et al. 33/483
4,872,268 A * 10/1989 Perrault 33/512
5,131,164 A * 7/1992 Miller 33/613
5,605,165 A * 2/1997 Sessions et al. 128/888
5,745,074 A * 4/1998 Laude 701/300
5,776,082 A * 7/1998 Riley et al. 600/594
6,159,167 A * 12/2000 Hardin-Naser 600/587
6,336,274 B1 * 1/2002 Ness Webster 33/474
6,467,179 B1 10/2002 Wolf
6,886,263 B2 * 5/2005 Chou 33/27.02
7,073,267 B2 * 7/2006 Butler et al. 33/203
7,082,692 B2 8/2006 Shapiro
7,343,688 B2 * 3/2008 Price 33/452
7,464,480 B2 * 12/2008 Vetromila 33/436
8,276,288 B1 * 10/2012 Yu 33/512
2003/0115765 A1 * 6/2003 Hajla 33/430
2006/0283032 A1 12/2006 Yang
2009/0299233 A1 * 12/2009 Wang et al. 600/595
2010/0004564 A1 * 1/2010 Jendle 600/587
2011/0098539 A1 * 4/2011 Estocado 600/300

FOREIGN PATENT DOCUMENTS

JP 2007225289 A 9/2007

* cited by examiner

Primary Examiner — Sean Dougherty

Assistant Examiner — Daniel Cerioni

(74) *Attorney, Agent, or Firm* — The Law Firm of Andrea Hence Evans, LLC

(57) **ABSTRACT**

A wound measuring device and system measures the length, width and depth of a wound. The device and system features first and second ruler members connected and secured by a connecting member which allows the ruler members to move to measure the length and width of a wound. The connecting member affords perpendicular movement of the ruler members providing accurate and consistent measurement of wounds irregular in shape and size. An end of the first or second member is designed to be inserted in the wound to measure the depth and undermining of the wound. Use of the device provides little to no discomfort to the patient.

3 Claims, 4 Drawing Sheets

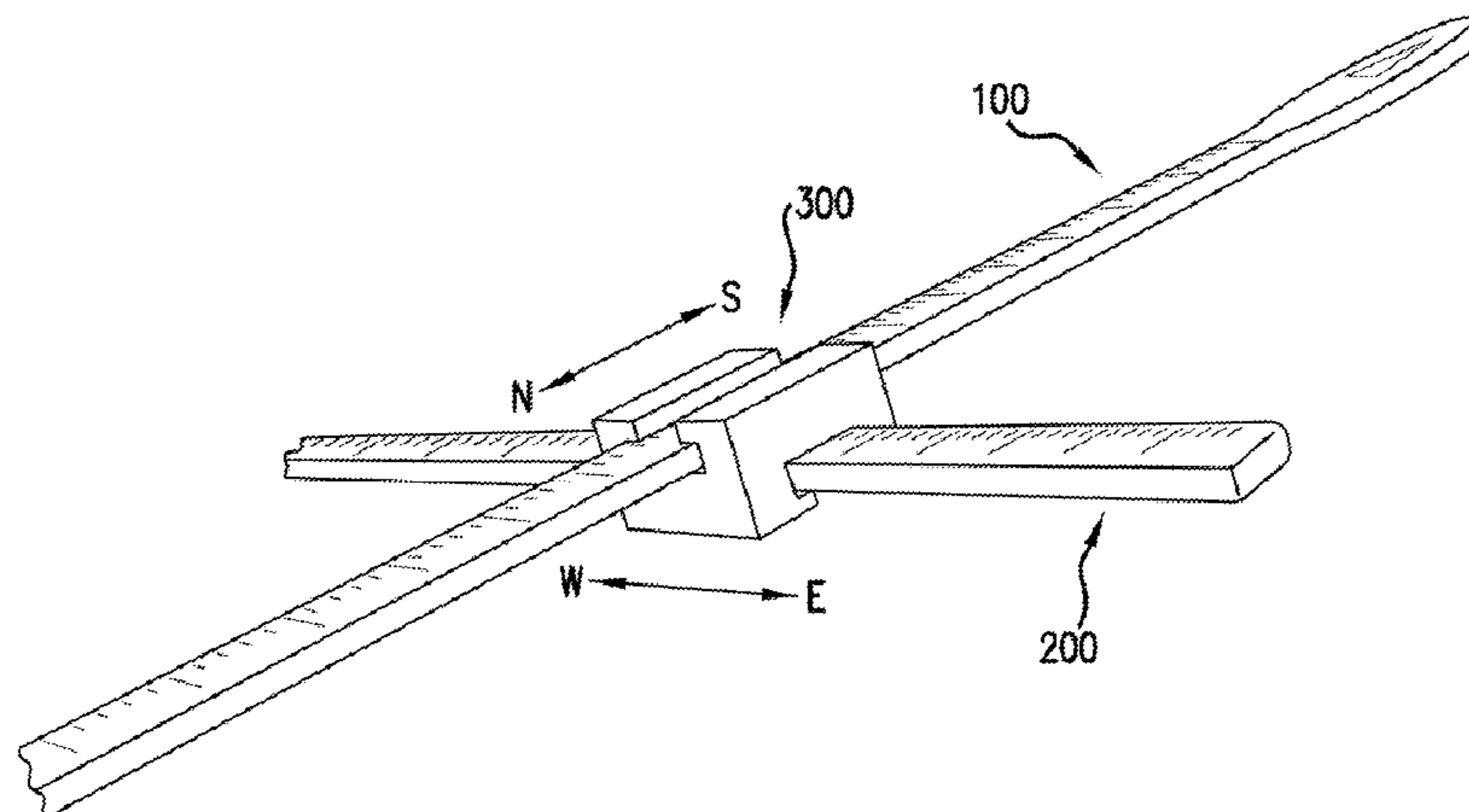

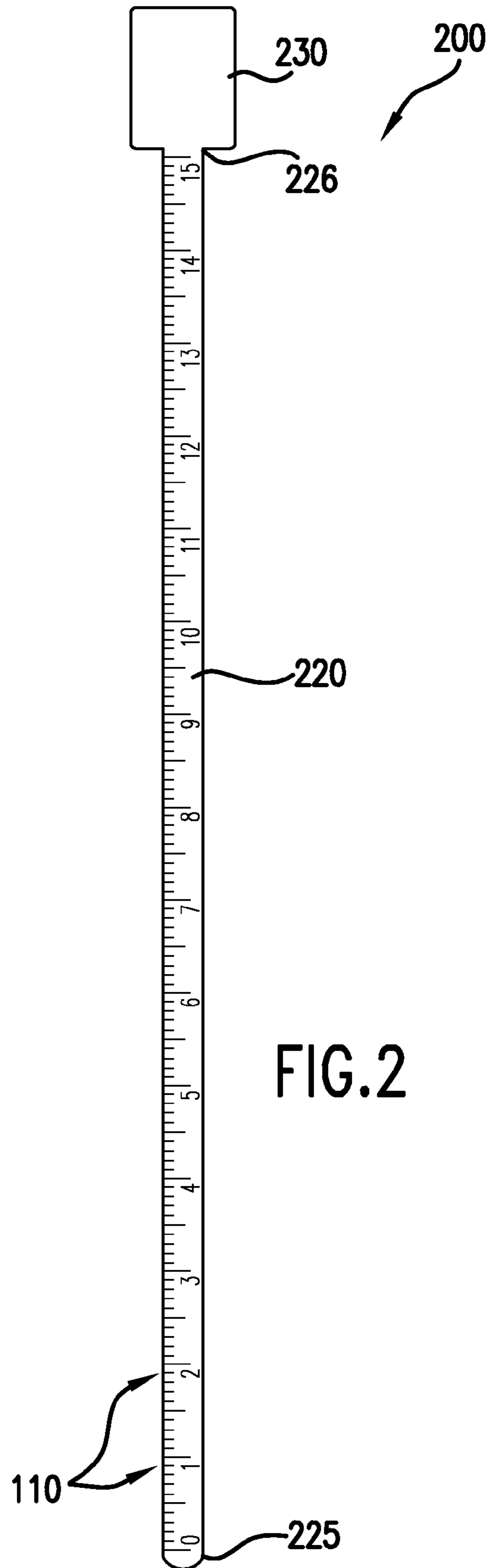
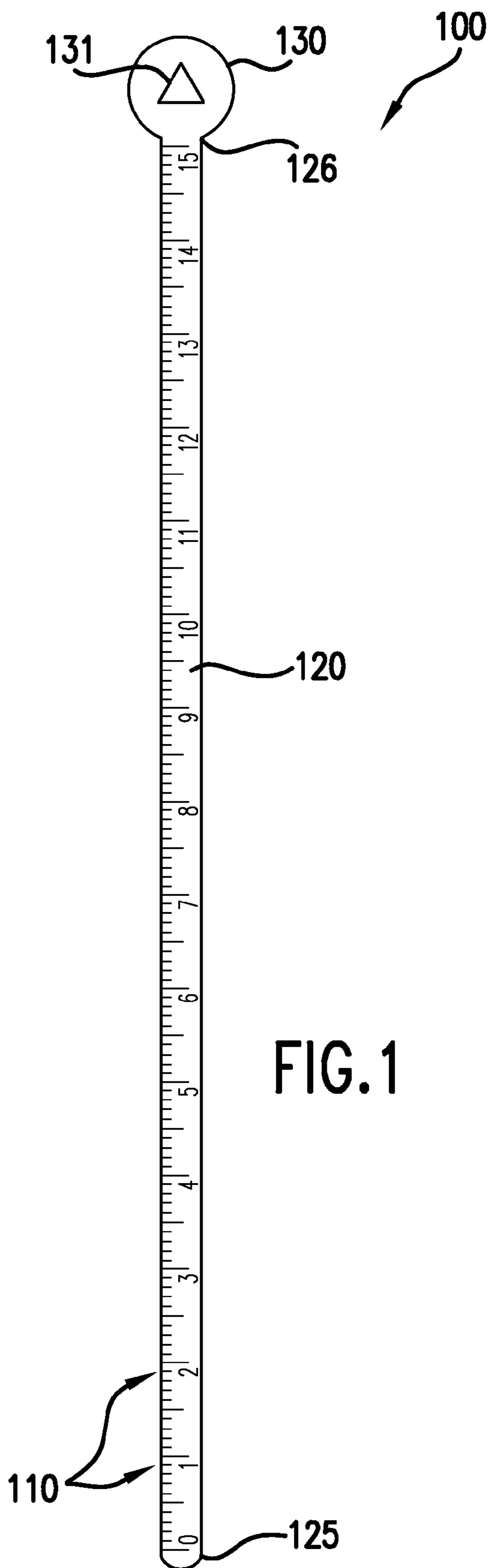

FIG. 1

FIG. 2

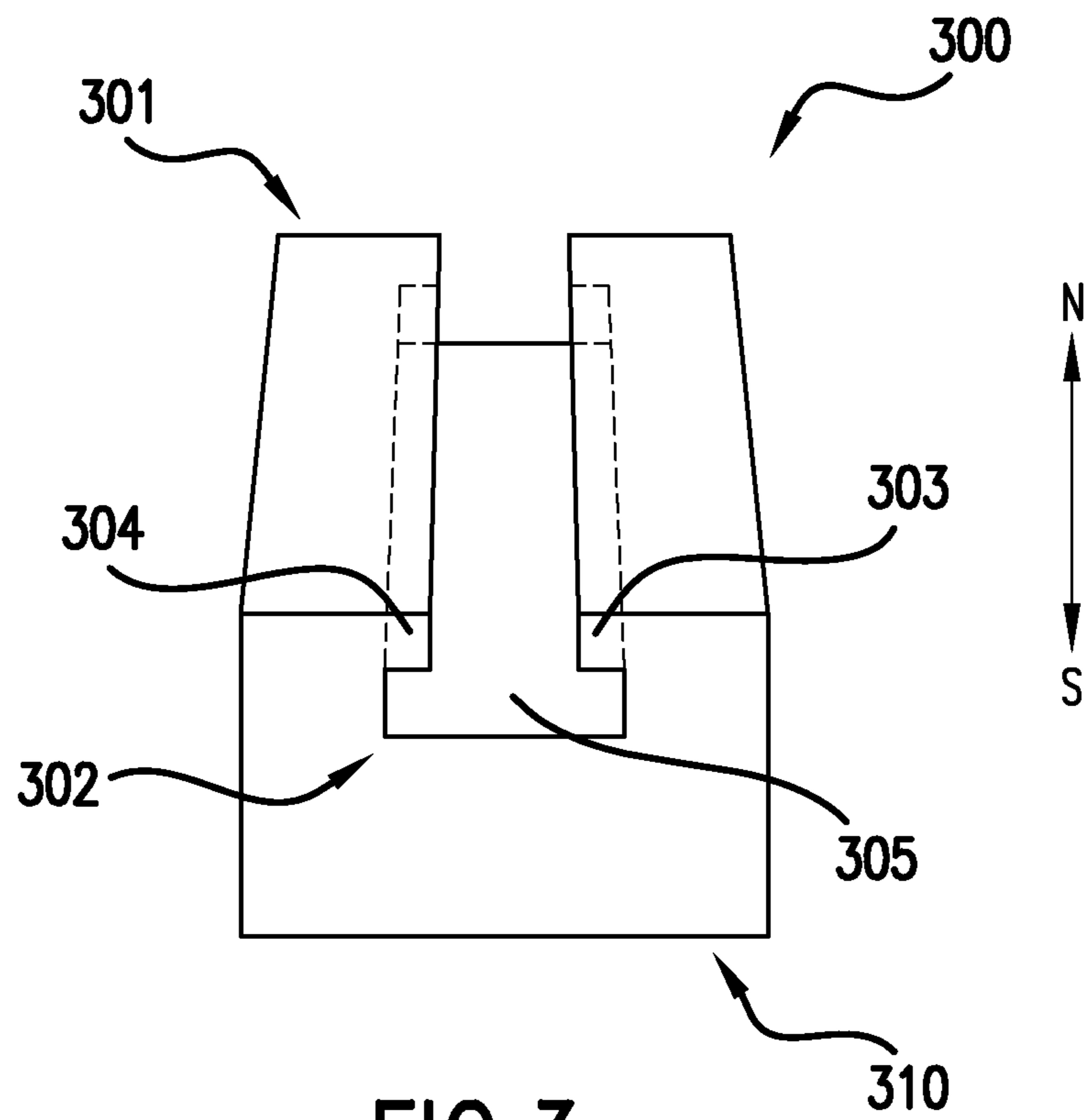

FIG. 3a

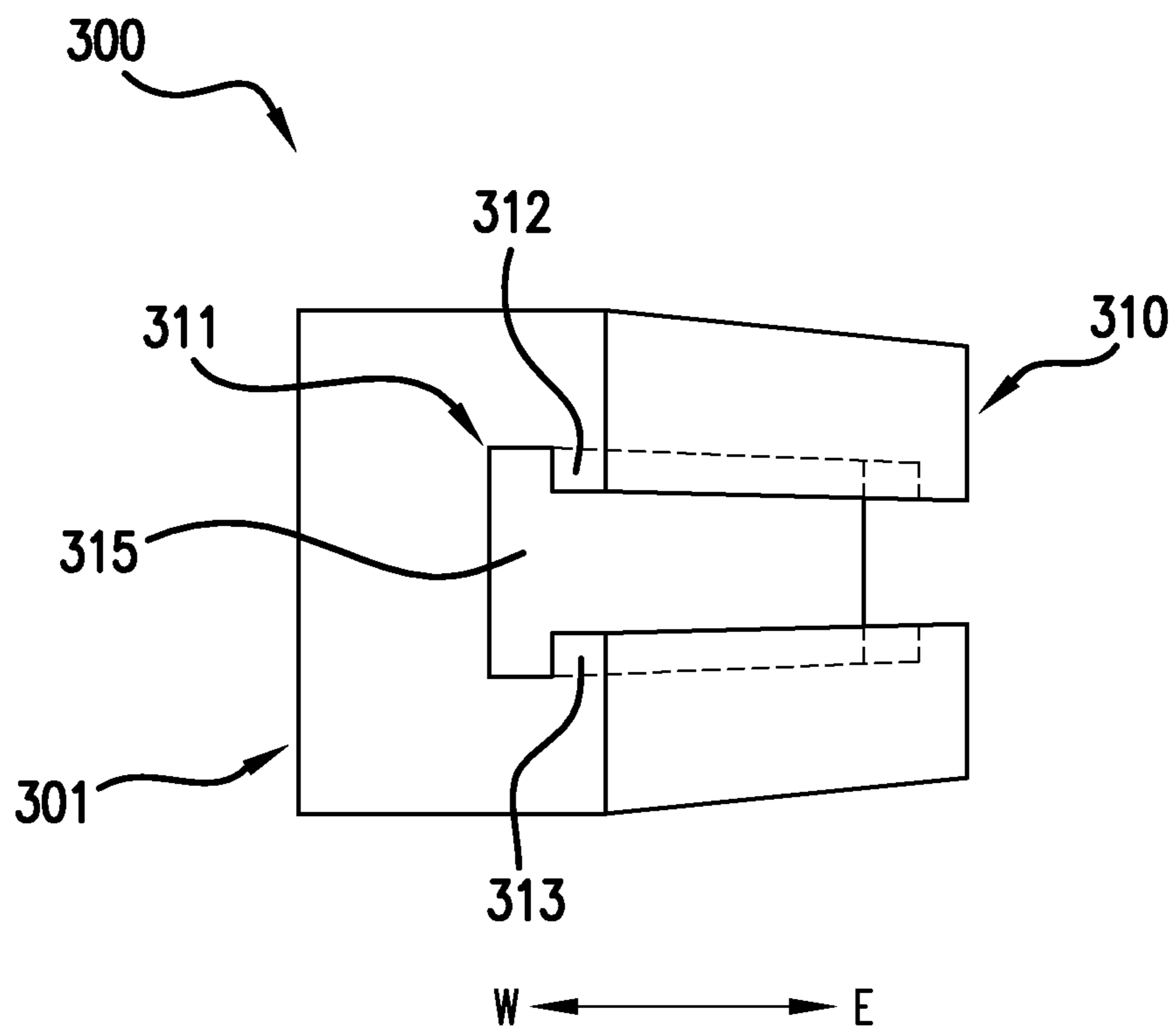

FIG. 3b

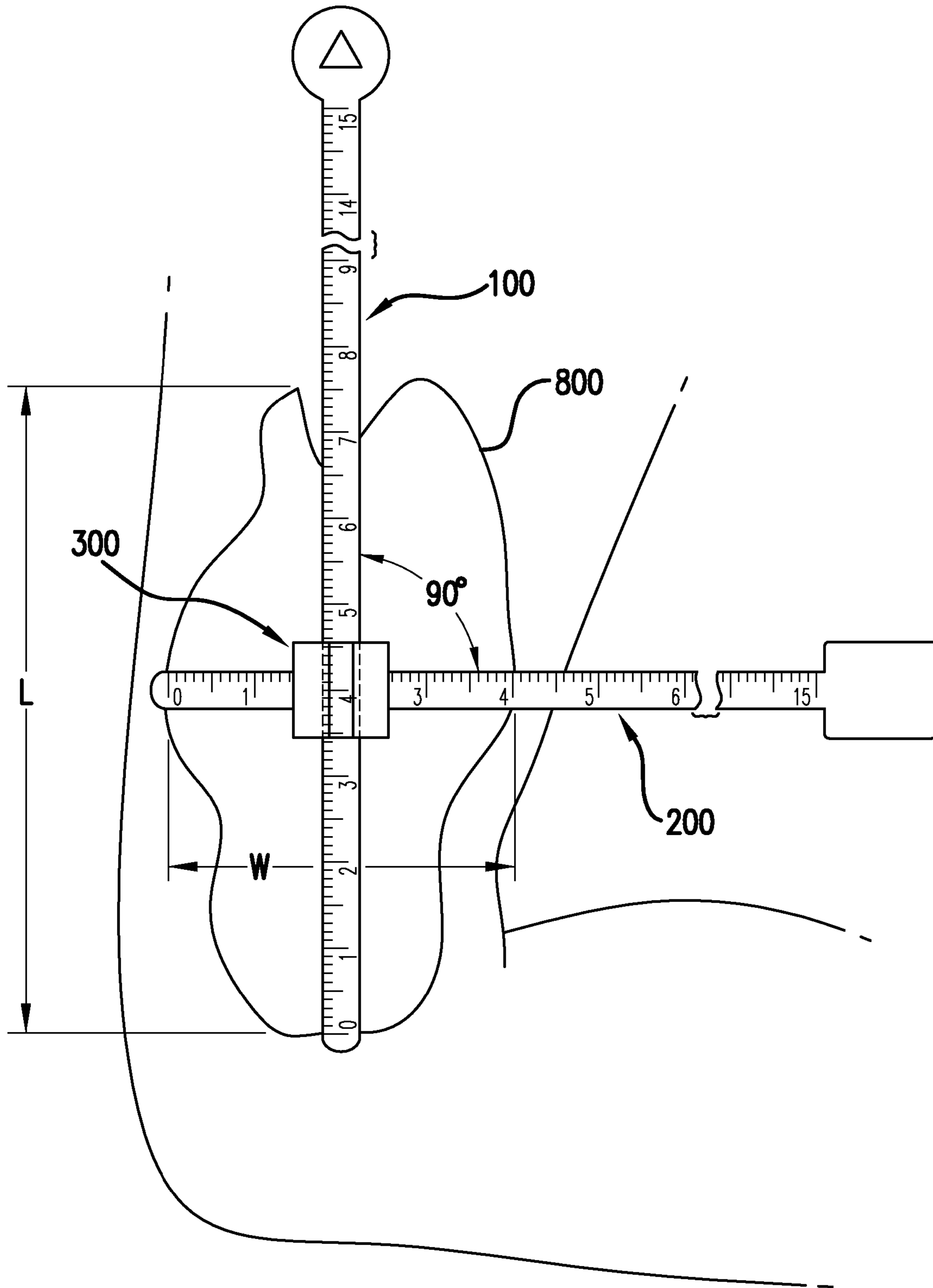

FIG.4

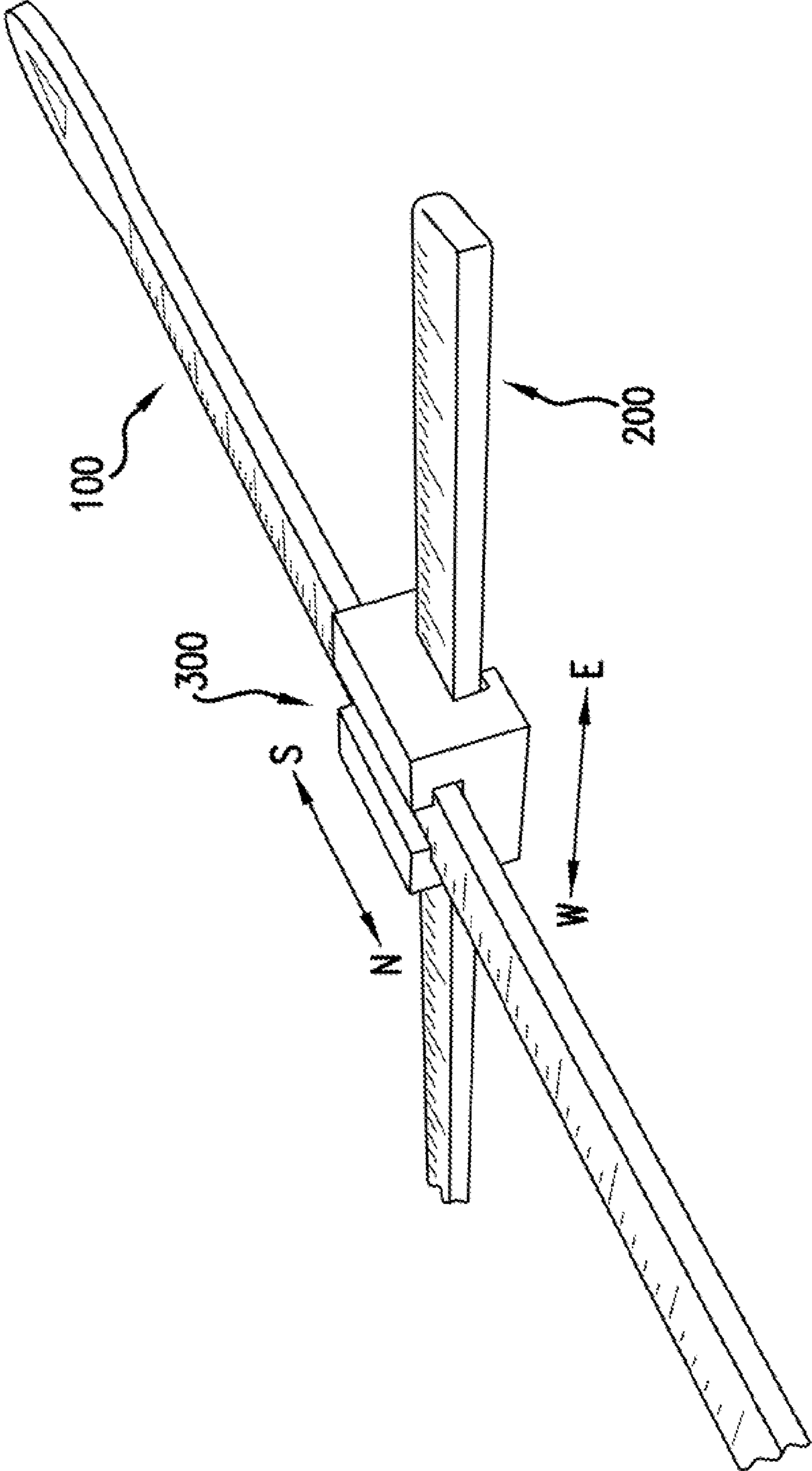

FIG.5

1

WOUND MEASURING DEVICE AND SYSTEM

RELATED U.S. APPLICATION DATA

This application claims the benefit of provisional applica- 5
tion number 61489391, filed May 24, 2011.

FIELD OF THE INVENTION

The present invention relates in general to a device and 10
system to measure wound size and more specifically to a
device and system which measures the length, width and
depth of a wound.

BACKGROUND OF THE INVENTION

Taking the measurements of a wound allows health care 15
providers to assess the level of tissue damage and to track the
healing process. This enables them to determine the appro-
priate measures to take and to record how well a particular
type of wound care is working. Members of the wound care 20
team do not use the same technique to determine the mea-
surements and the results may not be accurate. Measurements
are especially unreliable for large or irregular wounds due to
inconsistencies in measurements.

SUMMARY OF THE INVENTION

This invention introduces a measuring device and system 25
that measures wound sizes providing a more accurate com-
parison of measurements and healing or non-healing over
time.

An aspect of an embodiment of the invention features the 30
measuring device and system designed for use on curved or
flat body surfaces.

A further aspect of an embodiment of the invention fea- 35
tures the measuring device and system designed to measure
wounds irregular in shape and wounds that cover uneven
body surface.

A further aspect of an embodiment of the invention fea- 40
tures an accurate, inexpensive and consistent method of mea-
suring wounds.

A further aspect of an embodiment of the invention fea- 45
tures ruler members that identify the direction the ruler mem-
bers should be positioned on the wound.

A further aspect of an embodiment of the invention fea- 50
tures ruler members which are secured in a manner which
allows perpendicular movement so one member measures the
length of the wound and the other member measures the width
and either ruler member measures the depth of the wound.

Additional aspects, objectives, features and advantages of 55
the present invention will become apparent from the follow-
ing description of the preferred embodiments with reference
to the attached drawings.

BRIEF DESCRIPTION OF THE DRAWINGS

FIG. 1 is a perspective view of a first ruler member which 60
measures the length of the wound.

FIG. 2 is a perspective member of a second ruler member 65
which measures the width of the wound.

FIG. 3a is a top side of a perspective view of a connecting
device which secures and connects the first ruler member and
second ruler member.

FIG. 3b is a bottom side of a perspective view of a con-
necting device which secures and connects the first ruler
member and second ruler member.

2

FIG. 4 is a perspective view of the device illustrating the
connected first ruler member and second ruler member con-
nected by the connecting device measuring a wound.

FIG. 5 is a perspective view of the device illustrating the
connected first ruler member and second ruler member con-
nected by the connecting device.

DETAILED DESCRIPTION OF THE INVENTION

FIG. 1 is a perspective view of a first ruler member 100
which measures the length L of the wound 800, as shown in
FIG. 4. The first ruler member 100 is a straight strip having
measurement indicia 110. The marking indicia 110 are mark-
ings along a top surface 120 of the first ruler member 100. The
indicia 110 markings are marked at equal intervals along the
left or right top edge of the top surface 120 of the first ruler
member 100. A bottom end 125 or tip of the first ruler member
100 is marked with a "0" increment marking. A top end 126 of
the first ruler member 100 is marked with the largest incre-
ment, the length of the measuring area of the first ruler mem-
ber 100. A direction identifier 130 extends from the top end
126 with a marking or symbol 131 that identifies a direction
the first ruler member 100 should be positioned on an object
or wound 800 to be measured. The direction identifier may
also feature a design or symbol to identify the brand owner or
hospital or other identifier which will identify the maker or
owner of the tool. The identifier is preferably circular, how-
ever, alternate shapes may be used to display the identifier or
marking symbol. When the first ruler member 100 is posi-
tioned over a wound, 800, it is used to measure the length L of
the wound 800. The wound length L is a distance from an end
125 of the first ruler member 100 to a first end of a greatest
opening of the wound. The length measurement L is taken
when the first ruler member is positioned over the wound or
object to be measured.

FIG. 2 is a perspective member of a second ruler member
200 which measures the width W of the wound 800. The
second ruler member 200 is a straight strip having measure-
ment indicia 110. The marking indicia 110 are markings
along a top surface 220 of the second ruler member 200. The
indicia 110 markings are marked at equal intervals along the
left or right top edge of the top surface 220 of the second ruler
member 200. A bottom end 225 or tip of the second ruler
member 200 is marked with a "0" increment marking. A top
end 226 of the second ruler member 200 is marked with the
largest increment, the length of the measuring area of the
second ruler member 200. A handle 230 extends from the top
end 226 of the second ruler member 200. The handle 230
allows the user of the second ruler member 200 to manipulate
the second ruler member 200 to take measurements. The
handle 230 is rectangular in shape, however, an alternate
shape may be used. The handle 230 also features an area
which receives the wound owner's information such as name,
date, etc. A label may be placed on the handle with informa-
tion or it may be written directly on the handle 230. Measure-
ment indicia are not marked on the direction indicator 130 or
the handle 230. When the second ruler member 200 is posi-
tioned over a wound or object 800, it is used to measure the
width W of the wound 800. Wound width W is a distance from
an end of the connected second ruler member 225 to a second
end of the greatest opening of the wound.

The tip 125 of the first ruler member 100 or the tip 225 of
the second ruler member measures the depth of the object or
wound to be measured. The tip 125 of the first ruler member
100 or the tip 225 of the second ruler member 200 is inserted

inside of the wound or object its furthest distance inside of the wound or object to a surface of the wound to determine the wound depth.

The first and second ruler members **100, 200** are preferably light grey or transparent in color. When placed over the wound **800** or object, the light color or transparency affords the measurements to easily and accurately be taken and seen as well as it affords the measurer the ability to see the wound **800** or object to be measured underneath the rulers, **100, 200**. Additional light colors may be used so long as they do not obstruct the view of the measurer or conceal the object to be measured. The markings **110** are preferably in a black or other color that can easily be seen so that an accurate measurement may be identified. Markings **110** shown in FIGS. **1** and **2** are in centimeters. Ruler members **100, 200** provide measurements up to 15 cm in width and 15 centimeters in length. The markings may be shown in alternate metric units and the measurements may be increased or decreased to measure larger or shorter objects. The ruler members **100, 200** are flexible so they can be placed on curved body surfaces as well as flat body surfaces to accurately measure. Furthermore, the ruler members **100, 200** can easily be maneuvered over irregular sized objects to be measured. The rulers are sterilized for a one-time use. It is recommended for sanitary purposes that the rulers not be reused to avoid infections, for example. Open packages and unused ruler members should be discarded.

FIG. **3a** is a top side **301** of a perspective view of a connecting device **300** which secures and connects the first ruler member **100** and second ruler member **200**. The connection device **300** allows perpendicular movement of the first ruler member **100** and second ruler members **200** so that the rulers move in a sliding motion independent of each other. The connecting device **300** top side **301** features a first connector **302**. The first connector **302** features parallel first connector flanges **303, 304**. The flanges **303, 304** form a first channel **305** sized to receive the first ruler member **100**. The flanges' **303, 304** walls contact the left and right outermost edges of the first ruler members so that the first ruler member remains secure in the connector **302**. The first ruler member **100** can move back and forth or in and out freely through the channel. The connecting device is also a light grey or transparent color so that the markings on the ruler members remain visible. The channel has a bottom that receives and contacts a bottom side of the ruler member **100**. However, the area between the flanges **303, 304** remains open so the markings can easily be identified and measurements can be recorded.

FIG. **3b** is a bottom side **310** of a perspective view of the connecting device **300** which secures and connects the first ruler member **100** and second ruler member **200**. The bottom side **310** of the connecting device **300** is a second connector **311** having second connector parallel flanges **312, 313** that form a second channel **315** sized to receive the second ruler member **200**. The flanges **312, 313** walls contacts the left and right outermost edges of the second ruler members so that the second ruler member remains secure in the connector **310**. The second ruler member **200** can move back and forth or in and out freely through the channel **315**. The channel **315** has a bottom that receives and contacts a bottom side of the ruler member **200**. However, the area between the flanges **312, 313** remains open so the markings can easily be identified and measurements can be recorded. The first connector **301** and second connector **310** are attached so that the first connector's bottom side is secured to the second connector's bottom side. However, the first connector **301** is secured so that its channel **305** receives the first ruler member in a North to South direction so that the first ruler member **100** moves through the

channel **305** in an up and down direction, as shown in FIG. **5**. The second connector **310** is secured to the first connector so that its channel **315** receives the second ruler member in a East to West direction so that the second ruler member **200** moves through the channel **315** in a left to right direction, as shown in FIG. **5**. The connecting device affords the first ruler member and second ruler member the ability to move independently of each other so that when the connecting device secures the first and second ruler members, there is always a perpendicular angle between the first and second rulers.

FIG. **4** is a perspective view of the device illustrating the connected first ruler **100** member and second ruler member **200** connected by the connecting device **300** measuring a wound **800** on a body part such as a leg, for example. The connected ruler members form a measuring tool which may be used to measure the length, width and depth of a wound. The direction identifier **130** on the first ruler member identifies a direction the first ruler member **100** should be positioned on the wound **800** to be measured. The identifier is preferably an arrow, but another symbol may be used to identify which direction the ruler **100** should be positioned. The arrow should point to the wound owner's head, when the first ruler member **100** is placed over the wound opening. While keeping the arrow pointed towards the wound owner's head, the first ruler member **100** is adjusted so it measures the greatest expanse or opening of the wound from that direction. This is the wound length **L**. Without moving the first ruler member **100**, the second ruler member **200** is slide through the connecting device **300** so it measures the wound expanse or opening at the point where the greatest expanse or opening can be recorded. This is the wound width **W**. When connected, the first and second members, **100, 200** move perpendicular to each other. The wound length **L** and wound width **W** are recorded. Also, a time-marked camera may be used to take pictures of the placement and thus the measurements of the wound. Using the first ruler member tip **125** or second ruler member tip **225** where the indicator starts with "0" cm, the width depth and undermining is recorded as described above.

The use of the measuring tool is contraindicated for use in measuring burns, rash or other abrasions not resulting in a puncture, cut, scrape or tear. Also, the tool is contraindicated for use in measuring surgical incisions other than those experiencing dehiscence.

The invention has been described in detail with particular reference to certain preferred embodiments thereof, but it will be understood that variations and modifications can be effected within the spirit and scope of the invention.

The invention claimed is:

1. A method of measuring a wound having a first and second wound opening with a wound length, wound width and wound depth comprising:

providing a measuring tool having a first ruler member and a second ruler member;

wherein measurement indicia is on a top surface of the first ruler member and the second ruler member;

positioning the first ruler member over the wound opening; measuring the wound length with the first ruler, wherein the wound length is a distance from an end of the first ruler member at the first wound opening to a first end of a greatest opening of the wound;

providing a connecting member that connects the first ruler member and the second ruler member, so that the first and second member move perpendicular to each other; wherein the connecting member features a first connector having a first channel formed between first connector flanges, wherein the first channel receives the first ruler member and a second connector having a second chan-

nel formed between second connector flanges, wherein the second channel receives the second ruler member, wherein the connecting member further comprises a first aperture that extends from a top side of the first channel to a first side of the connecting member and a second aperture extending from a top side of the second channel to a second side of the connecting member, the first side of the connecting member being opposite the second side of the connecting member;

wherein the top side of the first channel and the top side of the second channel are proximate to the top surface of the first ruler member and the second ruler member, respectively;

connecting the second ruler member to the first ruler member;

measuring the wound width with the second ruler member, wherein the wound width is a distance from an end of the second ruler member at the second wound opening to a second end of the greatest opening of the wound;

wherein the first and second apertures are configured to permit visibility of the measuring indicia.

2. The method of claim **1** further comprising measuring the width depth with a first ruler member tip or second ruler member tip, wherein the width depth is a distance from the tip of the first or second ruler member placed its furthest distance inside of the wound to a surface of the wound.

3. The method of claim **1** further comprising providing a direction identifier on an end of the first ruler member that identifies a direction the first ruler member should be positioned on the wound to be measured.

* * * * *