

US008885023B2

(12) **United States Patent**
Thiel et al.

(10) **Patent No.:** **US 8,885,023 B2**
(45) **Date of Patent:** **Nov. 11, 2014**

(54) **SYSTEM AND METHOD FOR VIRTUAL CAMERA CONTROL USING MOTION CONTROL SYSTEMS FOR AUGMENTED THREE DIMENSIONAL REALITY**

(75) Inventors: **Aaron Thiel**, Durham, CT (US);
Michael Gay, Collinsville, CT (US);
Anthony Bailey, Wallingford, CT (US)

(73) Assignee: **Disney Enterprises, Inc.**, Burbank, CA (US)

(*) Notice: Subject to any disclaimer, the term of this patent is extended or adjusted under 35 U.S.C. 154(b) by 110 days.

(21) Appl. No.: **12/807,330**

(22) Filed: **Sep. 1, 2010**

(65) **Prior Publication Data**

US 2012/0050256 A1 Mar. 1, 2012

(51) **Int. Cl.**
G06T 15/00 (2011.01)
H04N 13/00 (2006.01)
G06T 19/00 (2011.01)

(52) **U.S. Cl.**
CPC **G06T 19/006** (2013.01); **H04N 13/004** (2013.01); **G06T 19/003** (2013.01)
USPC **348/47**

(58) **Field of Classification Search**
None
See application file for complete search history.

(56) **References Cited**

U.S. PATENT DOCUMENTS

5,423,554	A *	6/1995	Davis	463/4
5,973,807	A *	10/1999	Buchkremer et al.	359/25
8,014,985	B2 *	9/2011	Clavadetscher	703/6
2007/0223910	A1 *	9/2007	Aoki et al.	396/301
2007/0238981	A1 *	10/2007	Zhu et al.	600/424
2008/0263460	A1 *	10/2008	Altberg et al.	715/757
2009/0116732	A1 *	5/2009	Zhou et al.	382/154
2009/0170600	A1 *	7/2009	Komatsumoto	463/32

* cited by examiner

Primary Examiner — Sath V Perungavoor

Assistant Examiner — Kate Luo

(74) *Attorney, Agent, or Firm* — Farjami & Farjami LLP

(57) **ABSTRACT**

There is provided a system and method for integrating a virtual rendering system and a motion control system to provide an augmented three-dimensional reality. There is provided a method for integrating a virtual rendering system and a motion control system for outputting a composite three-dimensional render to a three-dimensional display, the method comprising obtaining, from the motion control system, a robotic three-dimensional camera configuration of a robotic three-dimensional camera in a real environment, programming the virtual rendering system using the robotic three-dimensional camera configuration to correspondingly control a virtual three-dimensional camera in a virtual environment, obtaining a virtually rendered three-dimensional feed using the virtual three-dimensional camera, capturing a video capture three-dimensional feed using the robotic three-dimensional camera, rendering the composite three-dimensional render by processing the feeds, and outputting the composite three-dimensional render to the three-dimensional display.

18 Claims, 4 Drawing Sheets

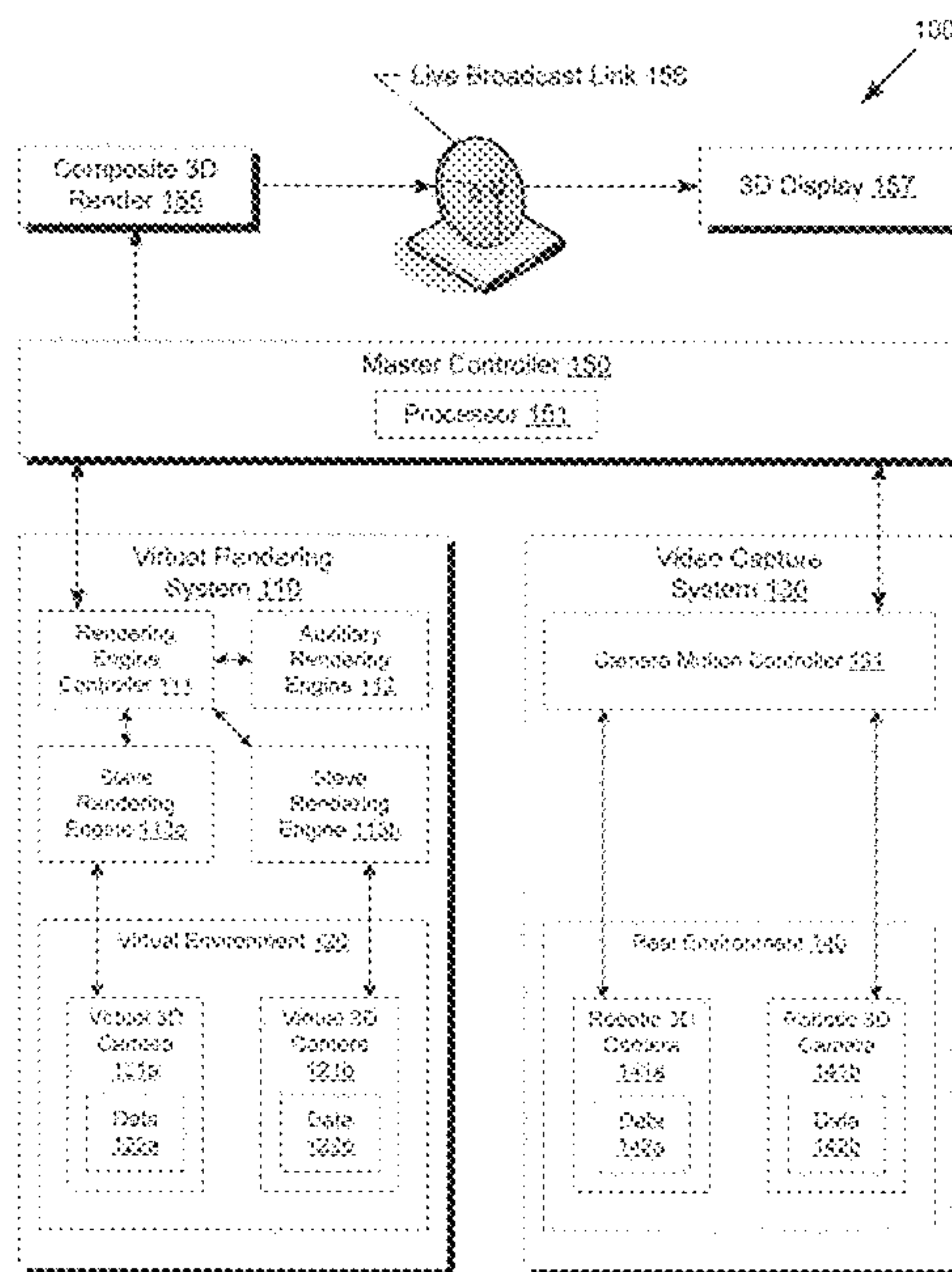

Fig. 1

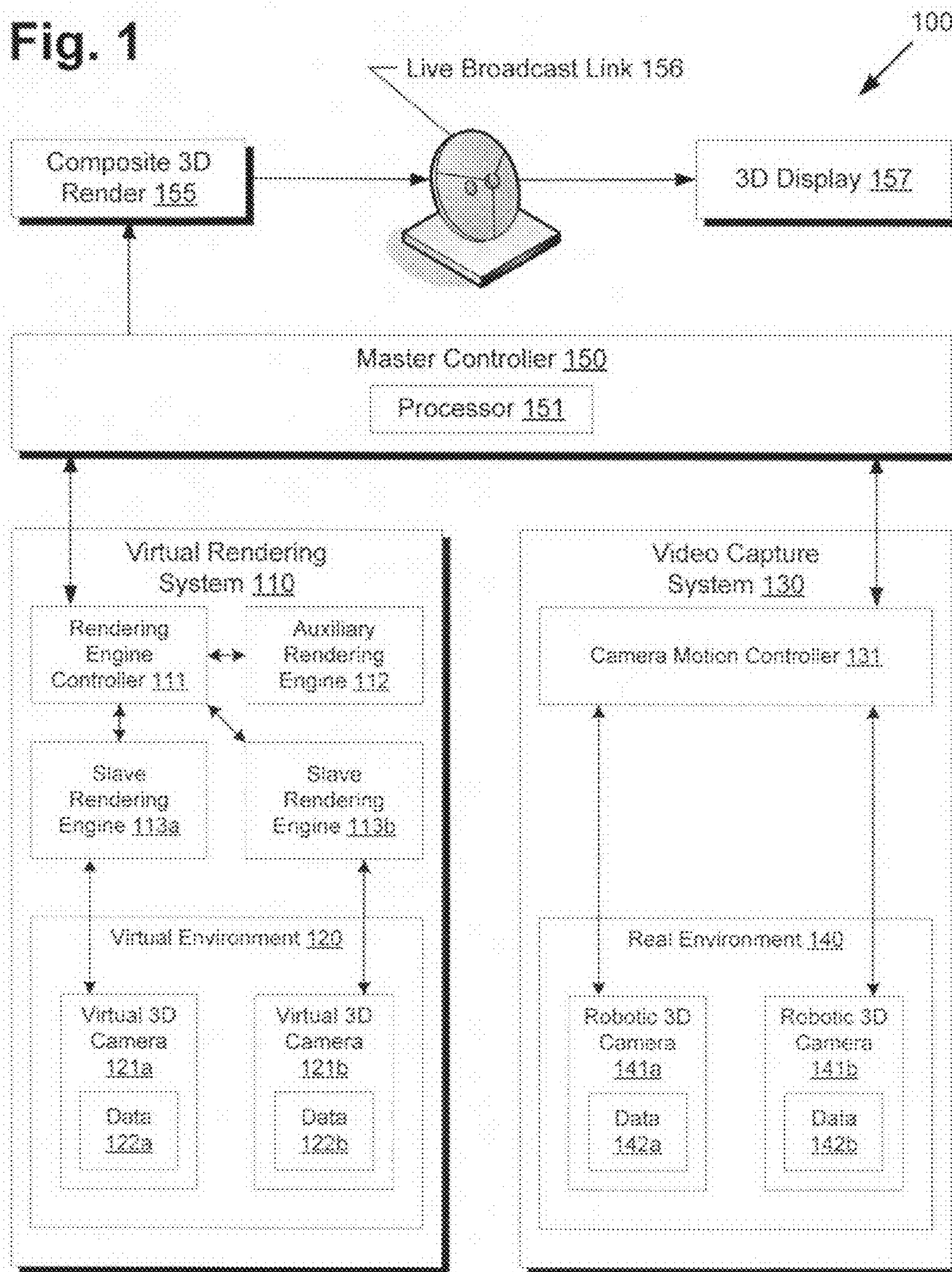

Fig. 2

200

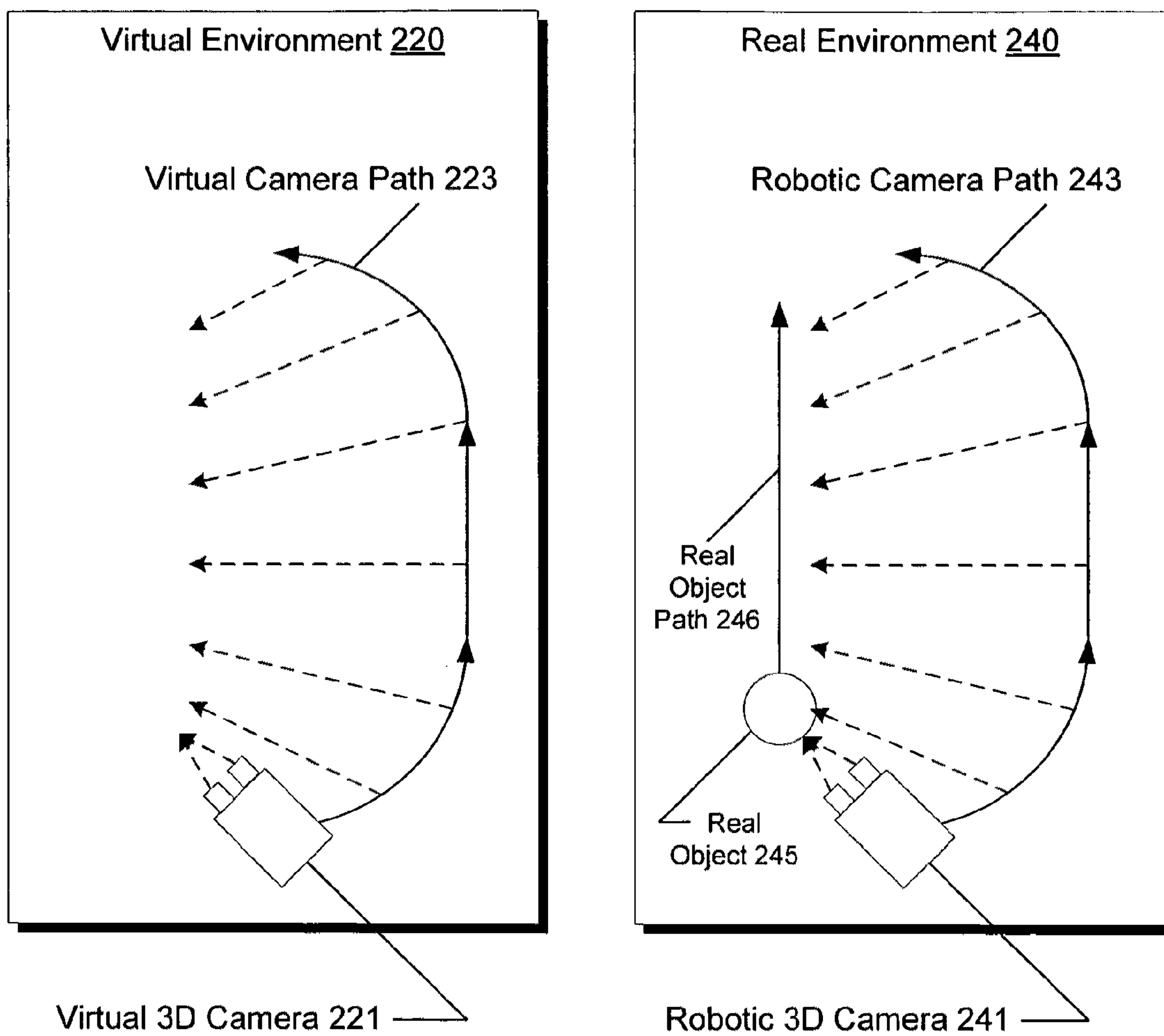

Fig. 3

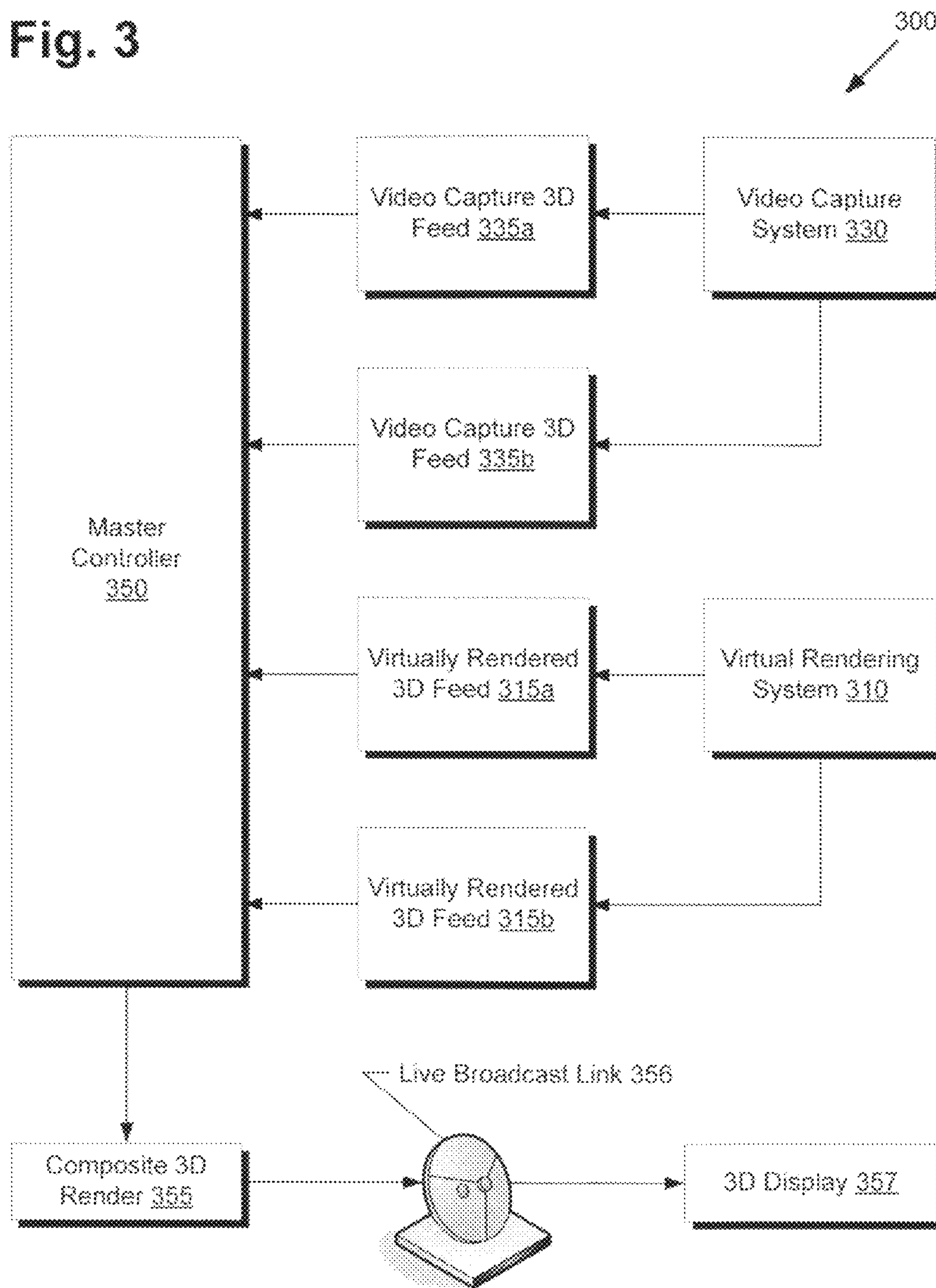
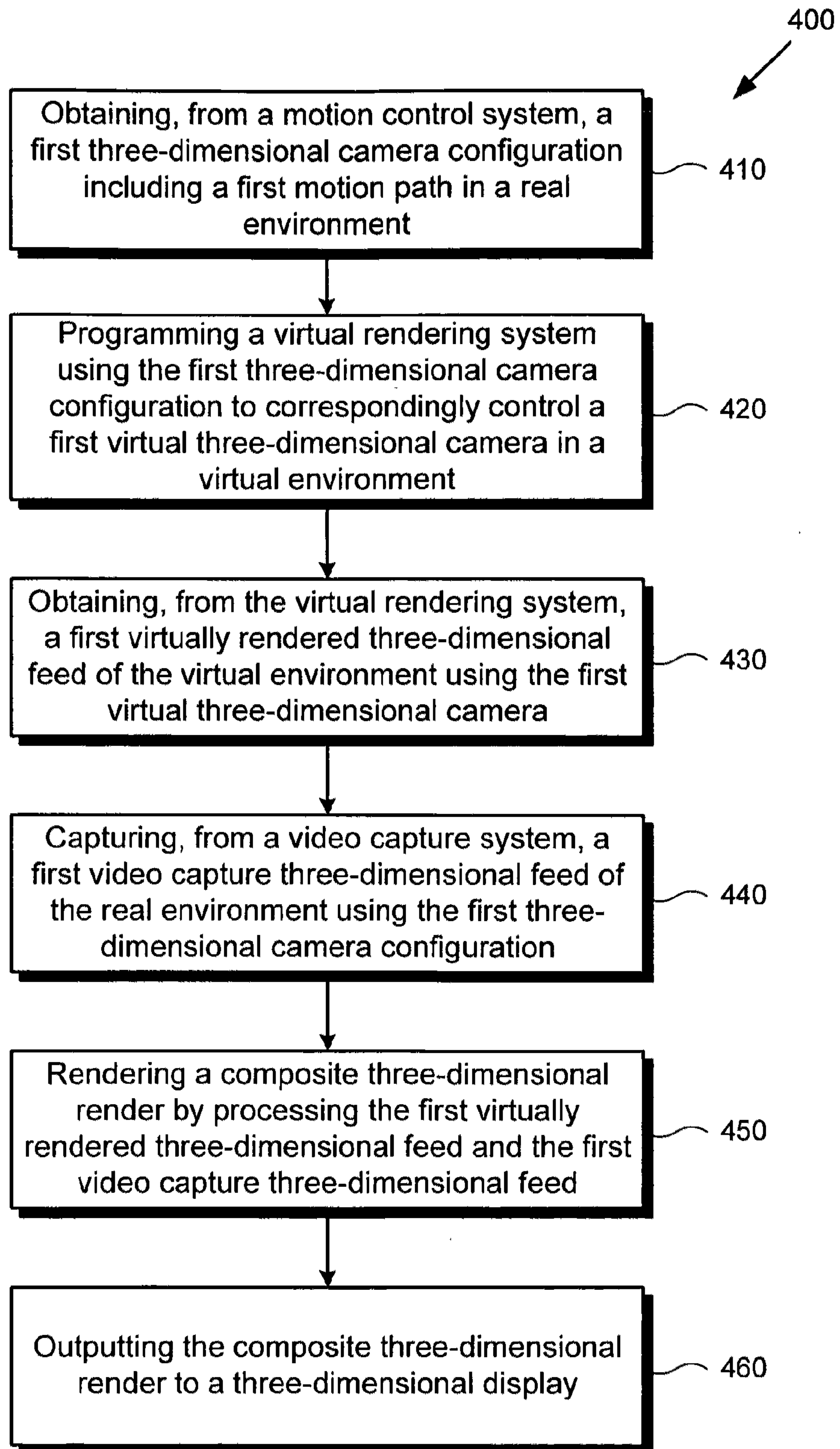

Fig. 4



1

**SYSTEM AND METHOD FOR VIRTUAL
CAMERA CONTROL USING MOTION
CONTROL SYSTEMS FOR AUGMENTED
THREE DIMENSIONAL REALITY**

BACKGROUND OF THE INVENTION

1. Field of the Invention

The present invention relates generally to digital video. More particularly, the present invention relates to digital video rendering.

2. Background Art

Modern commodity PC hardware and videogame consoles are often equipped with sufficient processing capability to enable high-resolution real-time three-dimensional graphics rendering. Even portable devices such as mobile phones and handheld gaming systems are often equipped with scaled down real-time three-dimensional graphics support. Such low-cost commodity graphics processing hardware has enabled a wide variety of entertainment and productivity applications to support enhanced visual presentations for greater user engagement and enjoyment.

In particular, real-time three-dimensional graphics rendering has found itself as a highly supportive role in live broadcast programming, especially for providing analysis and commentary. While materials such as pre-rendered animations or real life reenactments have been used previously for analysis and commentary, the time and resources required to produce such materials precludes their use for live events. Thus, for coverage of live sports and other events, low cost commodity graphics hardware can be utilized to provide timely analysis using composite renderings with real-time generated three-dimensional graphics, allowing the use of alternative or substitute object rendering, strategy simulations, information boxes, alternative viewpoints, and other effects.

While three-dimensional analysis tools exist for composite rendering, such tools cannot be used to accurately replay prior camera paths using manually controlled camera systems. As a result, important ongoing events such as a winning play or a brilliant strategy cannot be effectively analyzed. Furthermore, manually controlled camera systems are difficult to synchronize with virtual environment camera systems, as the camera operator cannot perceive the virtual environment. Absent such synchronization, it is difficult to create acceptable composite rendering within real-time constraints. As a result, viewer engagement is low since analysis is limited to imprecise and unsynchronized manually controlled camera movements. Moreover, since such analysis tools conventionally output only a standard two-dimensional composite rendering for output to a standard two-dimensional display, viewer engagement is further reduced as it becomes difficult for viewers to appreciate field depth and feel immersed into the rendered environment.

Accordingly, there is a need to overcome the drawbacks and deficiencies in the art by providing a way to create composite three-dimensional renderings using live three-dimensional footage and real-time three-dimensional graphics rendering for viewing on a three-dimensional display to provide high viewer impact and engagement.

SUMMARY OF THE INVENTION

There are provided systems and methods for integrating a virtual rendering system and a motion control system to provide an augmented three dimensional reality, substantially as

2

shown in and/or described in connection with at least one of the figures, as set forth more completely in the claims.

BRIEF DESCRIPTION OF THE DRAWINGS

5

The features and advantages of the present invention will become more readily apparent to those ordinarily skilled in the art after reviewing the following detailed description and accompanying drawings, wherein:

10 FIG. 1 presents a system for integrating a virtual rendering system and a motion control system to provide an augmented three-dimensional reality, according to one embodiment of the present invention;

15 FIG. 2 presents a diagram of a virtual three-dimensional camera path configured to match a robotic three-dimensional camera path used by a motion control system, according to one embodiment of the present invention;

20 FIG. 3 presents a diagram of a composite three-dimensional render being generated, according to one embodiment of the present invention; and

25 FIG. 4 shows a flowchart describing the steps, according to one embodiment of the present invention, by a virtual rendering system and a motion control system may be integrated for outputting a composite three-dimensional render of an augmented three-dimensional reality to a three-dimensional display.

DETAILED DESCRIPTION OF THE INVENTION

30 The present application is directed to a system and method for integrating a virtual rendering system and a motion control system to provide an augmented three-dimensional reality. The following description contains specific information pertaining to the implementation of the present invention. One skilled in the art will recognize that the present invention may be implemented in a manner different from that specifically discussed in the present application. Moreover, some of the specific details of the invention are not discussed in order not to obscure the invention. The specific details not described in the present application are within the knowledge of a person of ordinary skill in the art. The drawings in the present application and their accompanying detailed description are directed to merely exemplary embodiments of the invention. To maintain brevity, other embodiments of the invention, which use the principles of the present invention, are not specifically described in the present application and are not specifically illustrated by the present drawings.

35 FIG. 1 presents a system for integrating a virtual rendering system and a motion control system to provide an augmented three-dimensional reality, according to one embodiment of the present invention. Diagram 100 of FIG. 1 includes virtual rendering system 110, video capture system 130, master controller 150, composite 3D render 155, live broadcast link 156, and 3D display 157. Virtual rendering system 110 includes rendering engine controller 111, auxiliary rendering engine 112, slave rendering engines 113a-113b, and virtual environment 120. Virtual environment 120 includes virtual 3D cameras 121a-121b. Virtual 3D camera 121a includes data 122a. Virtual 3D camera 121b includes data 122b. Video capture system 130 includes camera motion controller 131 and real environment 140. Real environment 140 includes robotic 3D cameras 141a-141b. Robotic 3D camera 141a includes data 142a. Robotic 3D camera 141b includes data 142b. Master controller 150 includes processor 151.

40 Rendering engine controller 111, auxiliary rendering engine 112, slave rendering engine 113a, and slave rendering engine 113b may each execute on several separate servers,

65

each comprising standard commodity PC hardware or a videogame console system. Alternatively, the engines of virtual rendering system **110** may be consolidated into a single server, or distributed remotely across a network to minimize the amount of necessary on-site hardware. Rendering engine controller **111** may coordinate control and data sharing between the different rendering subsystems, as shown in FIG. **1**. Auxiliary rendering engine **112** may provide static graphics overlays and other graphical effects that do not require input from virtual environment **120**. Slave rendering engines **113a-113b** each control virtual cameras **121a-121b** respectively to receive a virtually rendered 3D feed of virtual environment **120**. For example, virtual 3D camera **121a** may include two virtual lenses spaced apart to provide a defined interocular distance for stereoscopic viewing. However, alternative embodiments may use more than two virtual lenses.

Real environment **140** corresponds to an actual physical environment represented by virtual environment **120**. For example, real environment **140** might comprise an indoor or outdoor sports field or stadium, a golf course, a natural environment, an urban environment, or any other locale. Besides sports entertainment environments, other environments for focuses such as educational or informational applications may also be used. Virtual environment **120** may then be created using manual three-dimensional environmental modeling, automated photographic or video extrapolation, or some other manual or automated method.

Data **142a-142b** describing the configuration of robotic 3D cameras **141a-141b** within real environment **140** may each include, for example, position data such as three-dimensional coordinates, camera field of view orientation data such as camera angle, focal length and focus distance, movement data such as a motion path or velocity and acceleration, and camera characteristics such as three-dimensional camera lens parameters, camera size, center of lens, and other camera model details. Since robotic 3D cameras **141a-141b** may each include two or more lenses to support 3D capture, the corresponding data **142a-142b** may contain parameters describing the three-dimensional lenses, such as the positioning and spacing between lenses to define interocular distance. Three-dimensional coordinates between virtual environment **120** and real environment **140** may be defined using a common frame of reference, such as setting a particular corner of a field or a particular landmark as a common (0, 0, 0) coordinate. The motion path may then describe the changing of the above data parameters with respect to time, such as the three-dimensional coordinates with respect to time, the camera field of view with respect to time, and the lens parameters with respect to time.

Master controller **150** may be executing a control program using processor **151** to receive data **142a-142b** from camera motion controller **131** of video capture system **130**. Camera motion controller **131** may, for example, query robotic 3D cameras **141a-141b** to retrieve data **142a-142b**, respectively. The motion path data in data **142a-142b** may be dictated by manual control such as by a camera operator, by tracking the motion of a particular object or focusing on a particular scene in either virtual environment **120** or real environment **140**, by replaying a previously recorded path of movement or another predetermined path, by a video analysis using video capture system **130**, or by using some other criteria. Tracked objects may include, for example, a ball or a participating player of a game such as a sports match, and may be virtual or real. Thus, robotic 3D cameras **141a-141b** can function as motion control cameras. Camera motion controller **131** might also accept user input to modify the motion paths contained in data **142a-142b**.

Processor **151** of master controller **150** may then direct virtual rendering system **110** to control virtual 3D cameras **121a-121b** according to the retrieved motion path data from data **142a-142b**. Once the virtual cameras are properly configured by appropriately programming the motion paths of data **122a-122b**, master controller **150** may then query virtual rendering system **110** for virtually rendered 3D feeds and video capture system **130** for video capture 3D feeds. Master controller **150** may then act as a rendering controller by combining the feeds smoothly using standard broadcast key technology such as chroma key or key/fill to generate composite 3D render **155**, which includes real and virtual 3D feed elements arranged in a specific desired manner for broadcast over live broadcast link **156** to 3D display **157**. Live broadcast link **156** may comprise, for example, a satellite uplink to a television studio, from where the broadcasted material is disseminated to the general public. 3D display **157** may then represent, for example, a 3D capable television of a viewer watching the broadcast. For example, 3D display **157** may alternate left and right images rapidly, for example at 120 frames per second, and the viewer may wear active shutter eyeglasses to direct the left and right images to the left and right eyes, respectively. Other methods of displaying 3D content or stereoscopy may also be utilized, such as filtered images for use with polarized glasses or a parallax barrier display.

Although virtual rendering system **110** of FIG. **1** depicts only two slave rendering engines each controlling exactly one virtual 3D camera, alternative embodiments may use any arbitrary number of slave rendering engines to control any arbitrary number of virtual 3D cameras. More specifically, each slave rendering engine may control more than one virtual 3D camera. Similarly, although video capture system **130** of FIG. **1** only depicts two robotic 3D cameras, alternative embodiments may use any arbitrary number of robotic 3D cameras to be controlled by camera motion controller **131** of video capture system **130**. In this manner, the composite 3D rendering system shown in FIG. **1** can be scaled to as many camera angles and viewpoints as desired, in either virtual environment **120** or real environment **140**.

FIG. **2** presents a diagram of a virtual three-dimensional camera path configured to match a robotic three-dimensional camera path used by a motion control system, according to one embodiment of the present invention. Diagram **200** of FIG. **2** includes virtual environment **220** and real environment **240**. Virtual environment **220** includes virtual 3D camera **221** and virtual camera path **223**. Real environment **240** includes robotic 3D camera **241**, robotic camera path **243**, real object **245**, and real object path **246**. With regards to FIG. **2**, it should be noted that virtual environment **220** corresponds to virtual environment **120** from FIG. **1** and that real environment **240** corresponds to real environment **140** from FIG. **1**. Moreover, although FIG. **2** only depicts a single virtual 3D camera and a single robotic 3D camera for simplicity, alternative embodiments may use multiple virtual 3D cameras and multiple robotic 3D cameras.

As previously discussed in FIG. **1**, master controller **150** may direct video capture system **130** to control virtual cameras according to motion paths provided by a motion control system. FIG. **2** shows an example of this manner of control, where robotic 3D camera **241**, comprising a motion control 3D camera such as a gantry supported fly-by 3D camera, is programmed to record a path of movement. For example, robotic 3D camera **241** may be programmed to focus on the movement of real object **245**, a football, following real object path **246**, a long distance pass. Thus, robotic 3D camera **241** may follow robotic camera path **243**, with camera orientation

5

following real object path **246** as indicated by the dotted arrows. As shown in diagram **200** of FIG. **2**, 3D cameras with multiple lenses may be configured to converge on an object of interest such as real object **245**. Robotic camera path **243** may then be recorded and programmed into virtual 3D camera **221** of virtual environment **220**, so that virtual 3D camera **221** can follow virtual camera path **223** mirroring robotic camera path **243**.

As shown in FIG. **2**, the camera orientation of virtual 3D camera **221** moves as if it were following real object path **246** within virtual environment **220**, even though there is no corresponding virtual object for real object **245** in virtual environment **220**. By using the system described above in FIG. **1**, virtual 3D camera **221** can thus be synchronized to the camera movements of robotic 3D camera **241**. Composite 3D rendering of real and virtual 3D environments, also known as “augmented 3D reality”, is thus facilitated, as the camera views in virtual environment **220** and real environment **240** can be matched according to any desired camera path, opening up limitless possibilities for dynamic camerawork. Previously recorded camera paths may also be recorded into storage for future replay, both by robotic 3D cameras and virtual 3D cameras.

The example shown in FIG. **2** might be used, for example, to present a dynamic panning camera view showing the long distance football pass defined by real object path **246** according to several virtual scenarios. For example, players might be virtually positioned and simulated in various scenarios to determine whether an alternative strategy might have resulted in an interception of the pass. Thus, a composite 3D render might show a real sports field background and the actual football, or real object **245**, in a video feed captured from real environment **240**, but with virtual players rendered in virtual environment **220**. Thus, the composite 3D render can provide a realistic camera fly-by with the football and background elements from real environment **240** and virtual players rendered from virtual environment **220**. Since the composite 3D render will be targeted for 3D displays, viewers can more easily appreciate field depth and feel immersed into the rendered 3D environment. Variations of this procedure may thus be used to present various hypothetical plays and strategy analyses in a realistic and engaging manner for high viewer impact.

FIG. **3** presents a diagram of a composite three-dimensional render being generated, according to one embodiment of the present invention. Diagram **300** of FIG. **3** includes virtual rendering system **310**, virtually rendered 3D feeds **315a-315b**, video capture system **330**, video capture 3D feeds **335a-335b**, master controller **350**, composite 3D render **355**, live broadcast link **356**, and 3D display **357**. With regards to FIG. **3**, it should be noted that virtual rendering system **310** corresponds to virtual rendering system **110** from FIG. **1**, that video capture system **330** corresponds to video capture system **130**, that master controller **350** corresponds to master controller **150**, that composite 3D render **355** corresponds to composite 3D render **155**, that live broadcast link **356** corresponds to live broadcast link **156**, and that 3D display **357** corresponds to 3D display **157**. For simplicity, certain elements are omitted from FIG. **3**, such as a processor for master controller **350**.

As shown in FIG. **3**, virtual rendering system **310** provides master controller **350** with virtually rendered 3D feeds **315a-315b**, while video capture system **330** provides master controller **350** with video capture 3D feeds **335a-335b**. For example, video capture 3D feed **335a** might correspond to a feed generated by robotic 3D camera **241** in FIG. **2**, whereas virtually rendered 3D feed **315a** might correspond to a feed

6

generated by virtual 3D camera **221** in FIG. **2**. Virtually rendered 3D feed **315b** may correspond to a feed created by an overhead virtual camera providing a bird’s eye overview of virtual environment **220** from FIG. **2**, whereas video capture 3D feed **335b** may correspond to a feed created by an overhead robotic camera providing a bird’s eye overview of real environment **240** from FIG. **2**.

Master controller **350** may then combine virtually rendered 3D feed **315a** and video capture 3D feed **335a** for an augmented reality fly-by scene and also combine virtually rendered 3D feed **315b** and video capture 3D feed **335b** for an augmented reality bird’s eye overview scene. As previously discussed, master controller **350** may use standard broadcast key technologies to combine the different feeds smoothly so that the juxtaposition of real and virtual elements is visually unobtrusive. Master controller **350** may then use these combined scenes in composite 3D render **355** through various presentation methods such as split screen, cascaded or tiled frames, “picture-in-picture”, three-dimensional surfaces, and other formatted layouts. Master controller **350** may then forward composite 3D render **355** over live broadcast link **356** for showing on 3D display **357**. Master controller **350** may repeat the above process of generating composite 3D render **355** in a periodic manner, such as 24, 30, or 60 times per second or higher in order to accommodate a desired video broadcasting framerate.

Although FIG. **3** only shows a single composite 3D render **355**, alternative embodiments may use several composite 3D renders. For example, master controller **350** may generate multiple composite 3D renders to provide different camera views for multiple broadcast channels, to customize based on a target broadcast region or audience demographics, to focus on a particular team in a sports match, or to support any other broadcasting application that may require multiple concurrent 3D video streams. By adding additional slave rendering engines and robotic cameras, augmented 3D reality rendering systems can be readily scaled and configured to support large-scale projects.

FIG. **4** shows a flowchart describing the steps, according to one embodiment of the present invention, by a virtual rendering system and a motion control system may be integrated for outputting a composite three-dimensional render of an augmented three-dimensional reality to a three-dimensional display. Certain details and features have been left out of flowchart **400** that are apparent to a person of ordinary skill in the art. For example, a step may comprise one or more substeps or may involve specialized equipment or materials, as known in the art. While steps **410** through **460** indicated in flowchart **400** are sufficient to describe one embodiment of the present invention, other embodiments of the invention may utilize steps different from those shown in flowchart **400**.

Referring to step **410** of flowchart **400** in FIG. **4** and diagram **100** of FIG. **1**, step **410** of flowchart **400** comprises obtaining, from camera motion controller **131** of video capture system **130**, data **142a** of robotic 3D camera **141a** in real environment **140**. Camera motion controller **131** may then retrieve data **142a** from robotic 3D camera **141a** for relaying back to master controller **150**. As previously described, data **142a** may contain various information concerning the configuration of robotic 3D camera **141a** such as three-dimensional position and movement, camera focus and view, camera model parameters, lens configuration for 3D capture, and other details.

Referring to step **420** of flowchart **400** in FIG. **4** and diagram **100** of FIG. **1**, step **420** of flowchart **400** comprises programming virtual rendering system **110** using data **142a** obtained from step **410** to correspondingly control virtual 3D

camera **121a** in virtual environment **120**. For example, master controller **150** may instruct rendering engine controller **111** to program values into data **122a** to match data **142a** as closely as possible. As previously discussed, data **142a** may include three-dimensional coordinates, camera field of view, and 3D lens parameters with respect to time. Assuming virtual 3D camera **221** and robotic 3D camera **241** correspond to virtual 3D camera **121a** and robotic 3D camera **141a**, the result of setting data **122a** to match data **142a** may be manifested by virtual camera path **223** mimicking robotic camera path **243**, as shown in FIG. 2.

Referring to step **430** of flowchart **400** in FIG. 4, diagram **200** of FIG. 2, and diagram **300** of FIG. 3, step **430** of flowchart **400** comprises obtaining, from virtual rendering system **310**, virtually rendered 3D feed **315a** of virtual environment **220** using virtual 3D camera **221**. Since the motion path of virtual camera **221** was previously programmed in step **420**, step **430** results in master controller **350** receiving virtually rendered 3D feed **315a** comprising fly-by footage according to virtual camera path **223**.

Referring to step **440** of flowchart **400** in FIG. 4, diagram **200** of FIG. 2, and diagram **300** of FIG. 3, step **440** of flowchart **400** comprises obtaining, from video capture system **330**, video capture 3D feed **335a** of real environment **240** using robotic 3D camera **241**. As previously discussed, robotic camera path **243** may be defined in any number of ways, such as by manual control, object tracking, recorded motion replay, or predetermined paths. As shown in FIG. 2, robotic camera path **243** is defined as an arc with the camera field of view following real object **245** as it progresses through real object path **246**. Thus, master controller **350** may receive video capture 3D feed **335a** comprising fly-by footage according to robotic camera path **243**, wherein the feed includes a rendering of real object **245**.

Referring to step **450** of flowchart **400** in FIG. 4 and diagram **300** of FIG. 3, step **450** of flowchart **400** comprises rendering composite 3D render **355** by processing video capture 3D feed **335a** from step **440** and virtually rendered 3D feed **315a** from step **430**. As previously discussed, master controller **350** may accomplish step **450** using standard broadcast key technology such as chroma key or key/fill techniques to isolate and combine components from each feed to produce a result with a smooth visual juxtaposition of real and virtual 3D elements.

Referring to step **460** of flowchart **400** in FIG. 4 and diagram **300** of FIG. 3, step **460** of flowchart **400** comprises outputting composite 3D render **355** from step **450** to 3D display **357**. As shown in FIG. 3, master controller **350** may send composite 3D render **355** using live broadcast link **356**, which might comprise a satellite uplink to a broadcast station for public dissemination. Eventually, composite render **355** shows on 3D display **357**, which might comprise the television of a viewer at home. As previously discussed, various 3D display technologies may be used such as active shutter glasses, polarized glasses, or parallax barrier.

While the above steps **410-460** have been described with respect to a single virtual 3D camera, a single robotic 3D camera, and a single composite 3D render, steps **410-460** may also be repeated as necessary to support multiple virtual 3D cameras, multiple robotic 3D cameras, and multiple composite 3D renders, as previously described. In this manner, the described rendering system can be flexibly scaled to larger projects by increasing the number of slave rendering systems and robotic 3D cameras to handle additional 3D feeds in real-time.

In this manner, live events such as sports can be enhanced with high-impact augmented 3D reality segments by leverag-

ing the cost effective real-time graphical capabilities of modern commodity PC hardware and game consoles. This can provide networks with a competitive advantage by drawing in and retaining greater viewership by providing compelling augmented reality 3D content while requiring only minor additional infrastructure outlays over standard rendering systems. Since commodity hardware parts are used and numerous effective virtual rendering systems and engines are available for licensing, expensive proprietary systems and vendor lockout may be avoided, further reducing total cost of ownership.

From the above description of the invention it is manifest that various techniques can be used for implementing the concepts of the present invention without departing from its scope. Moreover, while the invention has been described with specific reference to certain embodiments, a person of ordinary skills in the art would recognize that changes can be made in form and detail without departing from the spirit and the scope of the invention. As such, the described embodiments are to be considered in all respects as illustrative and not restrictive. It should also be understood that the invention is not limited to the particular embodiments described herein, but is capable of many rearrangements, modifications, and substitutions without departing from the scope of the invention.

What is claimed is:

1. A method for integrating a virtual rendering system and a motion control system to output a composite three-dimensional render to a three-dimensional display, the method comprising:

obtaining, from the motion control system, a first three-dimensional camera configuration, wherein the first three-dimensional camera configuration includes camera position data, camera field of view orientation data, camera movement data and camera lens characteristics data;

programming the virtual rendering system using the first three-dimensional camera configuration to correspondingly control a first virtual three-dimensional camera in a virtual environment;

obtaining, from the virtual rendering system, a first virtually rendered three-dimensional feed of the virtual environment using the first virtual three-dimensional camera;

capturing, from a video capture system, a first video capture three-dimensional feed of a real environment using the first three-dimensional camera configuration;

rendering the composite three-dimensional render, based on a target broadcast region, by processing the first virtually rendered three-dimensional feed and the first video capture three-dimensional feed, wherein the composite three-dimensional render includes simulating at least one virtual player with a real tracked object; and

outputting the composite three-dimensional render to the three-dimensional display.

2. The method of claim 1, wherein the first three-dimensional camera configuration includes a first motion path in the real environment, and the first motion path includes a three-dimensional position with respect to time.

3. The method of claim 1, wherein the first three-dimensional camera configuration includes a first motion path in the real environment, and the first motion path includes a camera orientation or field of view with respect to time.

4. The method of claim 1, wherein the camera lens characteristics data includes three-dimensional camera lens parameters.

9

5. The method of claim 1, wherein the first three-dimensional camera configuration includes a first motion path in the real environment, and the first motion path is based on a predetermined path.

6. The method of claim 1, wherein the first three-dimensional camera configuration includes a first motion path in the real environment, and the first motion path is based on a previously recorded path.

7. The method of claim 1, wherein the first three-dimensional camera configuration includes a first motion path in the real environment, and the first motion path is based on a video analysis using the video capture system.

8. The method of claim 1, wherein the first three-dimensional camera configuration includes a first motion path in the real environment, and wherein the method further comprising prior to the programming of the virtual rendering system, modifying the first motion path according to a user input.

9. The method of claim 1 further comprising prior to the rendering of the composite three-dimensional render:

obtaining, from the motion control system, a second three-dimensional camera configuration including a second motion path in the real environment;

programming the virtual rendering system using the second three-dimensional camera configuration to correspondingly control a second virtual three-dimensional camera in the virtual environment;

obtaining, from the virtual rendering system, a second virtually rendered three-dimensional feed of the virtual environment using the second virtual three-dimensional camera;

capturing, from a video capture system, a second video capture three-dimensional feed of the real environment using the second three-dimensional camera configuration;

wherein the rendering of the three-dimensional composite render further processes the second virtually rendered three-dimensional feed and the second video capture three-dimensional feed.

10. A rendering controller for outputting a composite three-dimensional render to a three-dimensional display, the rendering controller comprising:

a processor configured to:

obtain, from a motion control system, a first three-dimensional camera configuration, wherein the first three-dimensional camera configuration includes camera position data, camera field of view orientation data, camera movement data and camera lens characteristics data;

program a virtual rendering system using the first three-dimensional camera configuration to correspondingly control a first virtual three-dimensional camera in a virtual environment;

obtain, from the virtual rendering system, a first virtually rendered three-dimensional feed of the virtual environment using the first virtual three-dimensional camera;

capture, from a video capture system, a first video capture three-dimensional feed of a real environment using the first three-dimensional camera configuration;

render the composite three-dimensional render, based on a target broadcast region, by processing the first

10

virtually rendered three-dimensional feed and the first video capture three-dimensional feed, wherein the composite three-dimensional render includes simulating at least one virtual player with a real tracked object; and

output the composite three-dimensional render to the three-dimensional display.

11. The rendering controller of claim 10, wherein the first three-dimensional camera configuration includes a first motion path in the real environment, and the first motion path includes a three-dimensional position with respect to time.

12. The rendering controller of claim 10, wherein the first three-dimensional camera configuration includes a first motion path in the real environment, and the first motion path includes a camera orientation or field of view with respect to time.

13. The rendering controller of claim 10, wherein the camera lens characteristics data includes three-dimensional camera lens parameters.

14. The rendering controller of claim 10, wherein the first three-dimensional camera configuration includes a first motion path in the real environment, and the first motion path is based on a predetermined path.

15. The rendering controller of claim 10, wherein the first three-dimensional camera configuration includes a first motion path in the real environment, and the first motion path is based on a previously recorded path.

16. The rendering controller of claim 10, wherein the first three-dimensional camera configuration includes a first motion path in the real environment, and the first motion path is based on a video analysis using the video capture system.

17. The rendering controller of claim 10, wherein the first three-dimensional camera configuration includes a first motion path in the real environment, and wherein prior to the programming of the virtual rendering system, the processor is configured to modify the first motion path according to a user input.

18. The rendering controller of claim 10, wherein prior to the rendering of the composite three-dimensional render the processor is configured to:

obtain, from the motion control system, a second three-dimensional camera configuration including a second motion path in the real environment;

program the virtual rendering system using the second three-dimensional camera configuration to correspondingly control a second virtual three-dimensional camera in the virtual environment;

obtain, from the virtual rendering system, a second virtually rendered three-dimensional feed of the virtual environment using the second virtual three-dimensional camera; and

capture, from a video capture system, a second video capture three-dimensional feed of the real environment using the second three-dimensional camera configuration;

wherein the processor is configured to render the composite three-dimensional render by further processing the second virtually rendered three-dimensional feed and the second video capture three-dimensional feed.

* * * * *