

(56)

References Cited

U.S. PATENT DOCUMENTS

7,129,803 B2 10/2006 Khorram et al.
7,269,391 B2 9/2007 Chiu et al.
8,294,514 B2 * 10/2012 Visser et al. 330/2
8,436,695 B2 * 5/2013 Mu 333/25
2005/0043007 A1 2/2005 Rofougaran et al.
2006/0001487 A1 1/2006 Petrovic et al.
2009/0039977 A1 2/2009 Lee et al.

2011/0299431 A1 12/2011 Mikhemar et al.

OTHER PUBLICATIONS

Long, J., "Monolithic Transformers for Silicon RF IC Design," IEEE Journal of Solid-State Circuits, Sep. 2000, pp. 1368-1382, vol. 35, No. 9.
International Search Report mailed Mar. 8, 2012 in re International application PCT/SE2011/051423.

* cited by examiner

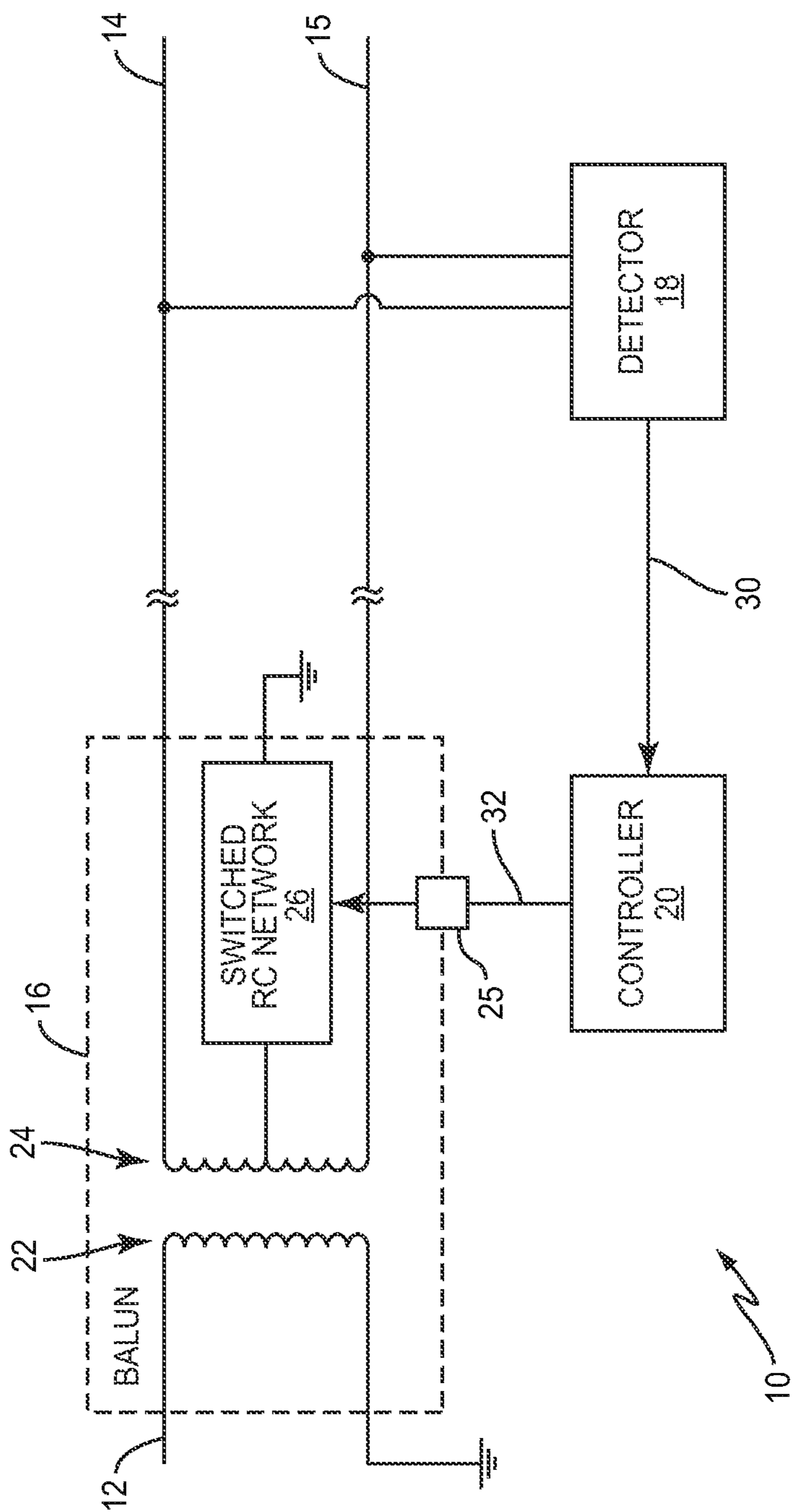

FIG. 1

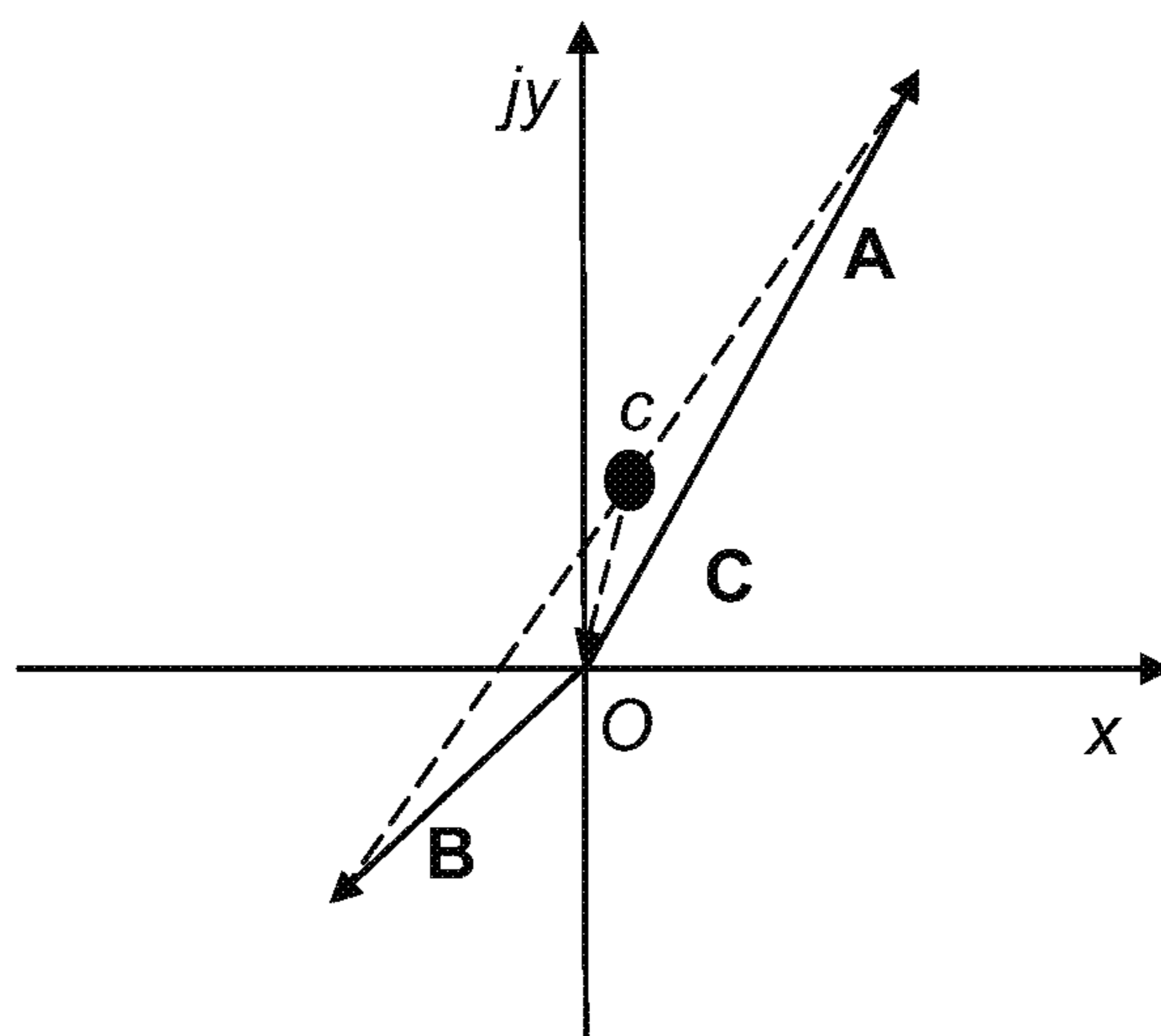

FIG. 2A

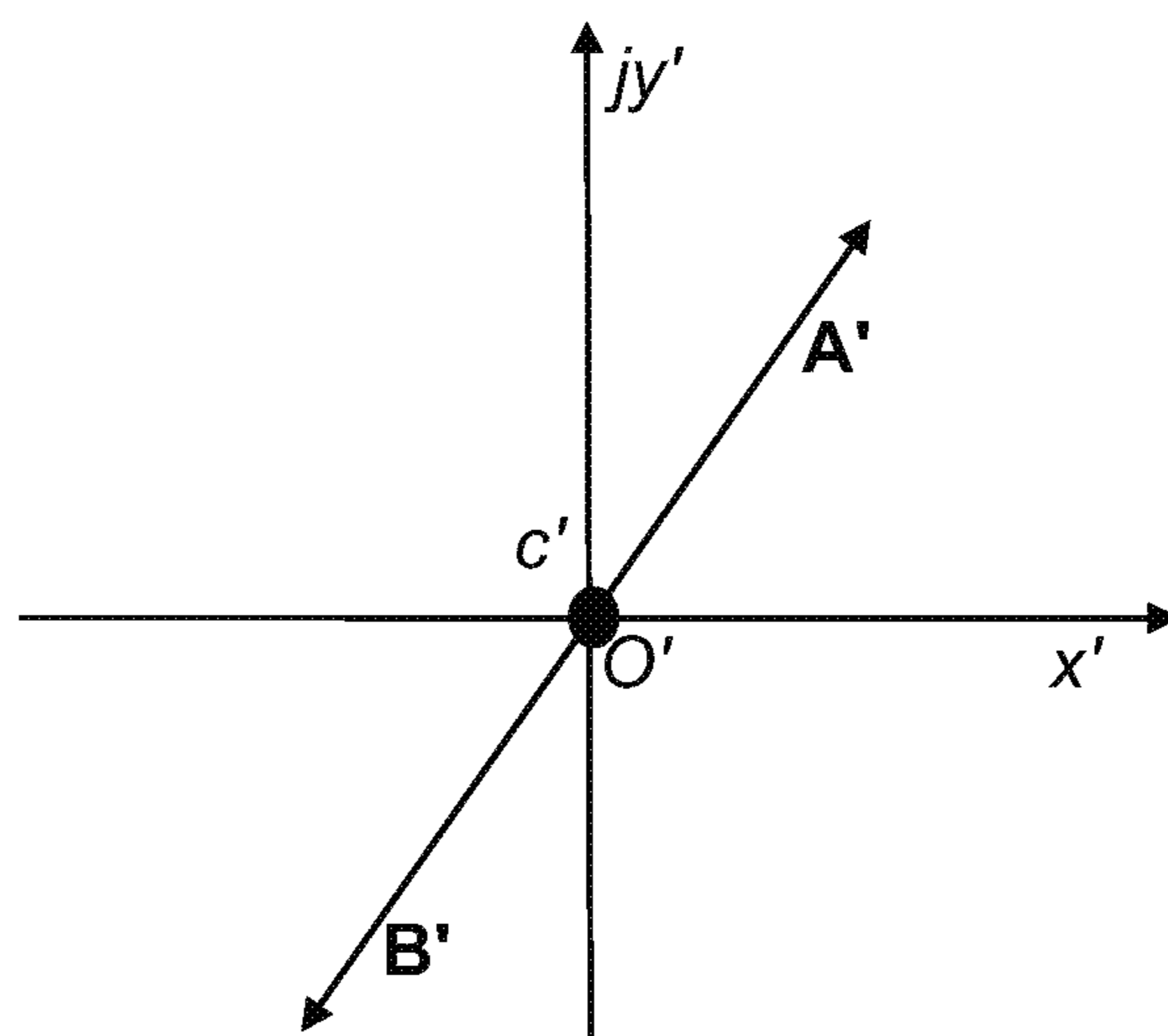

FIG. 2B

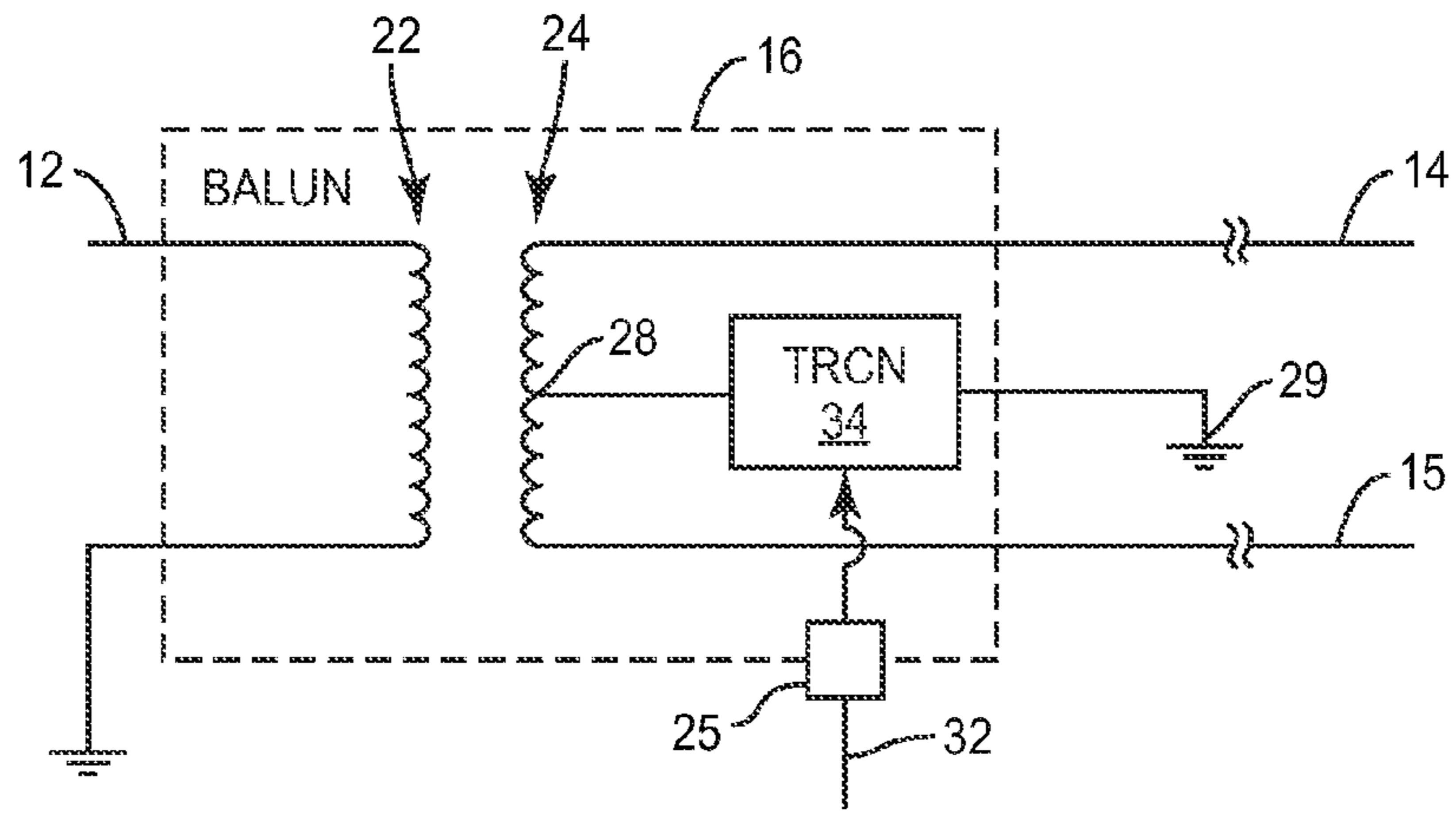

FIG. 3

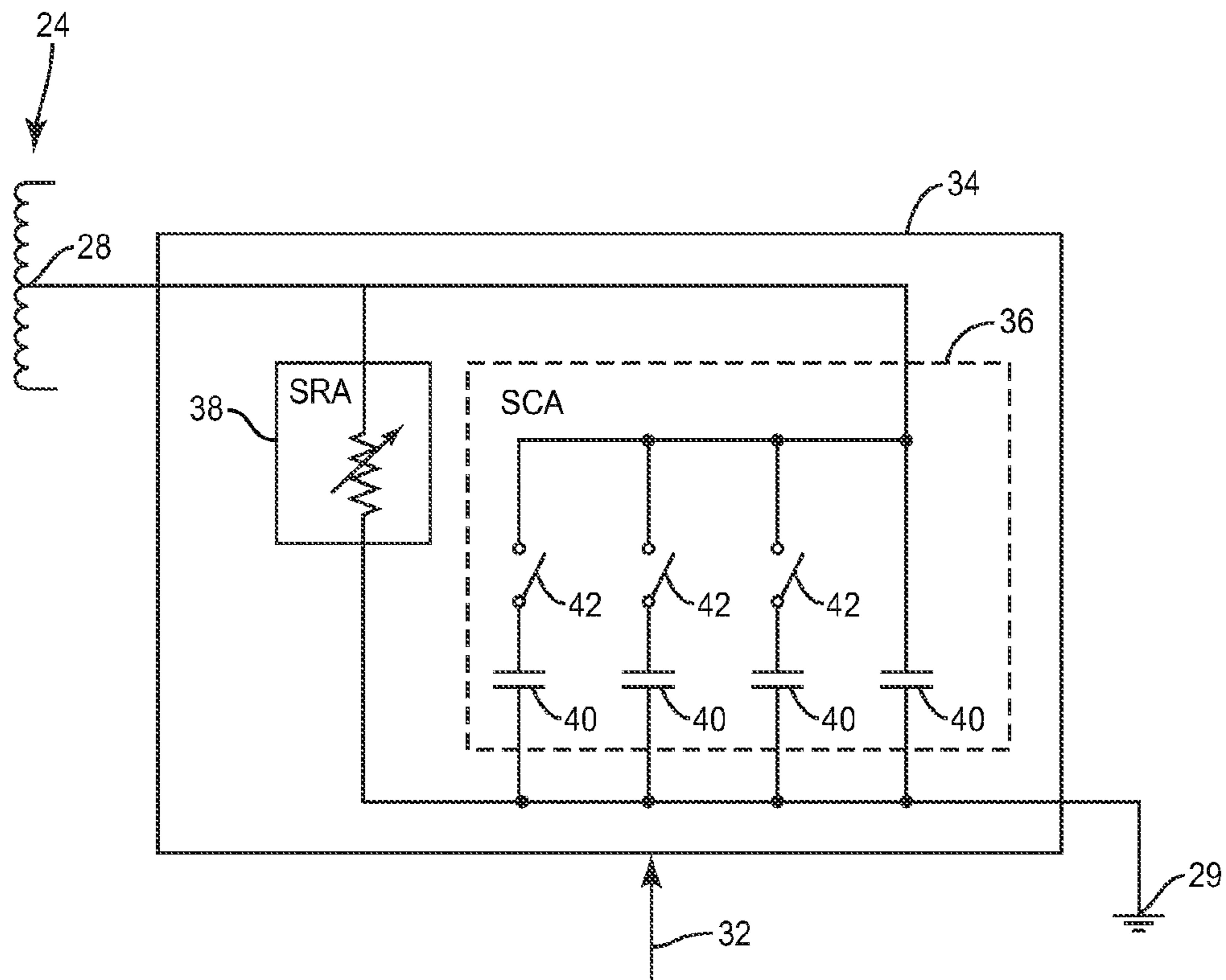

FIG. 4

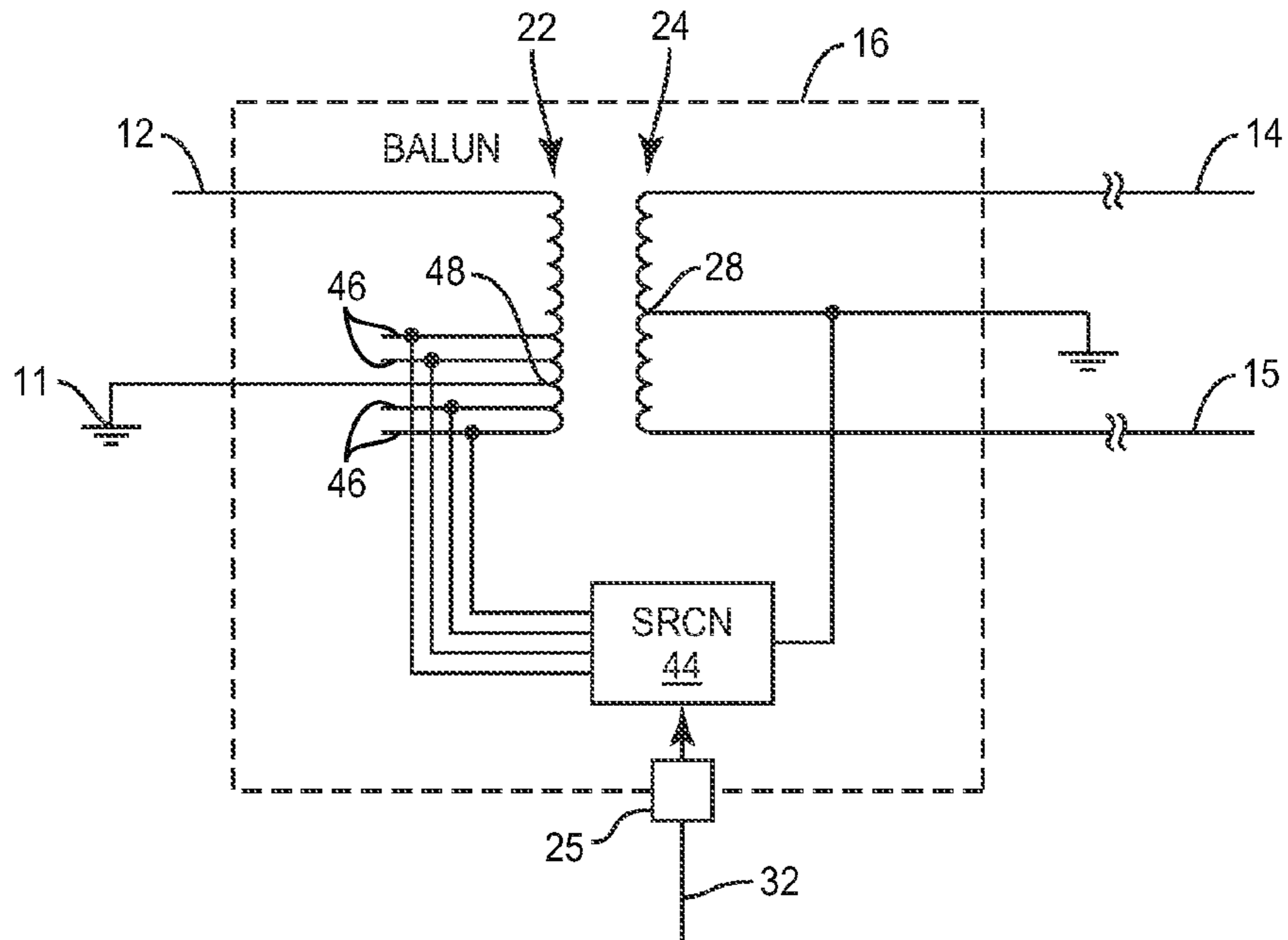

FIG. 5

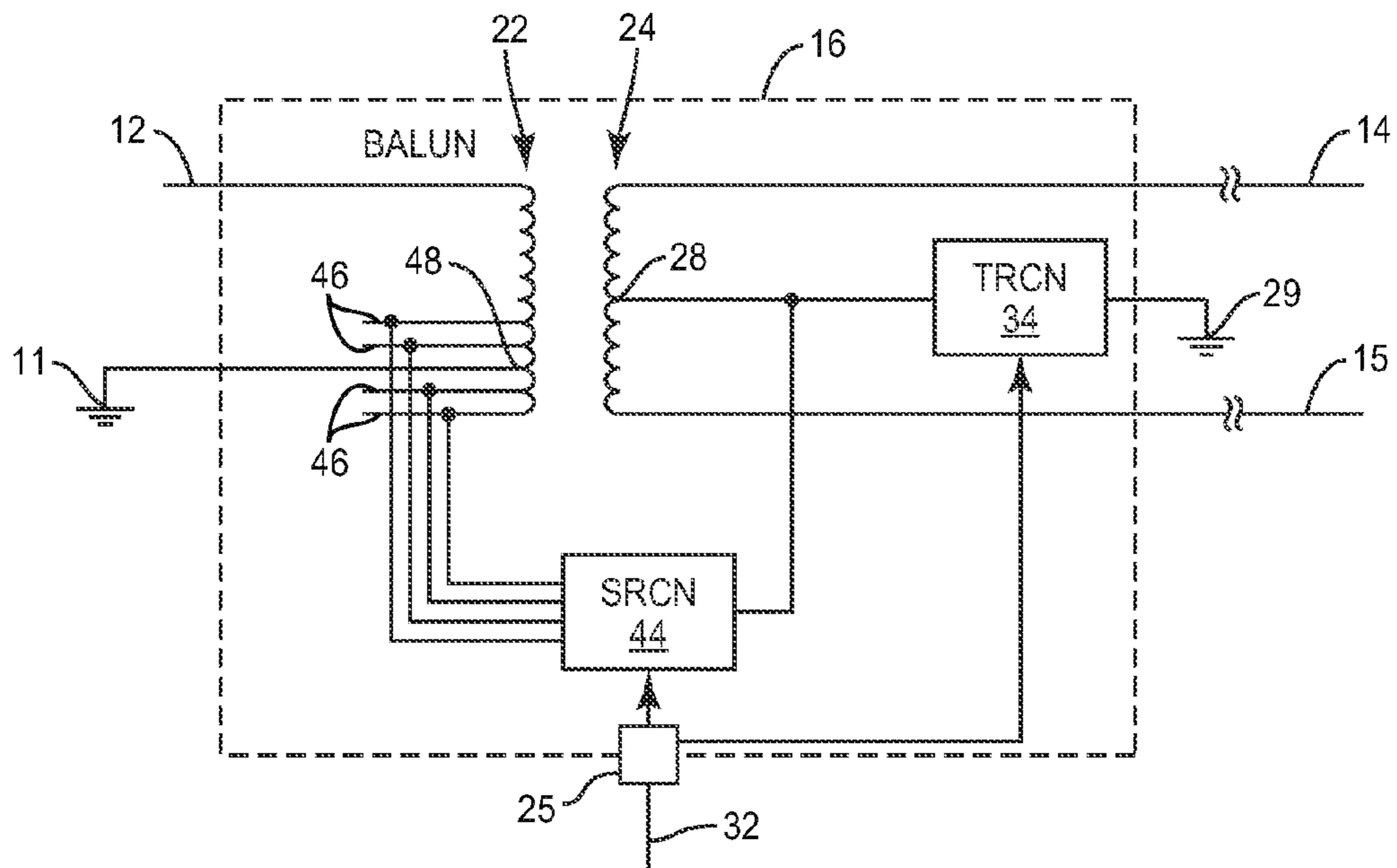

FIG. 6

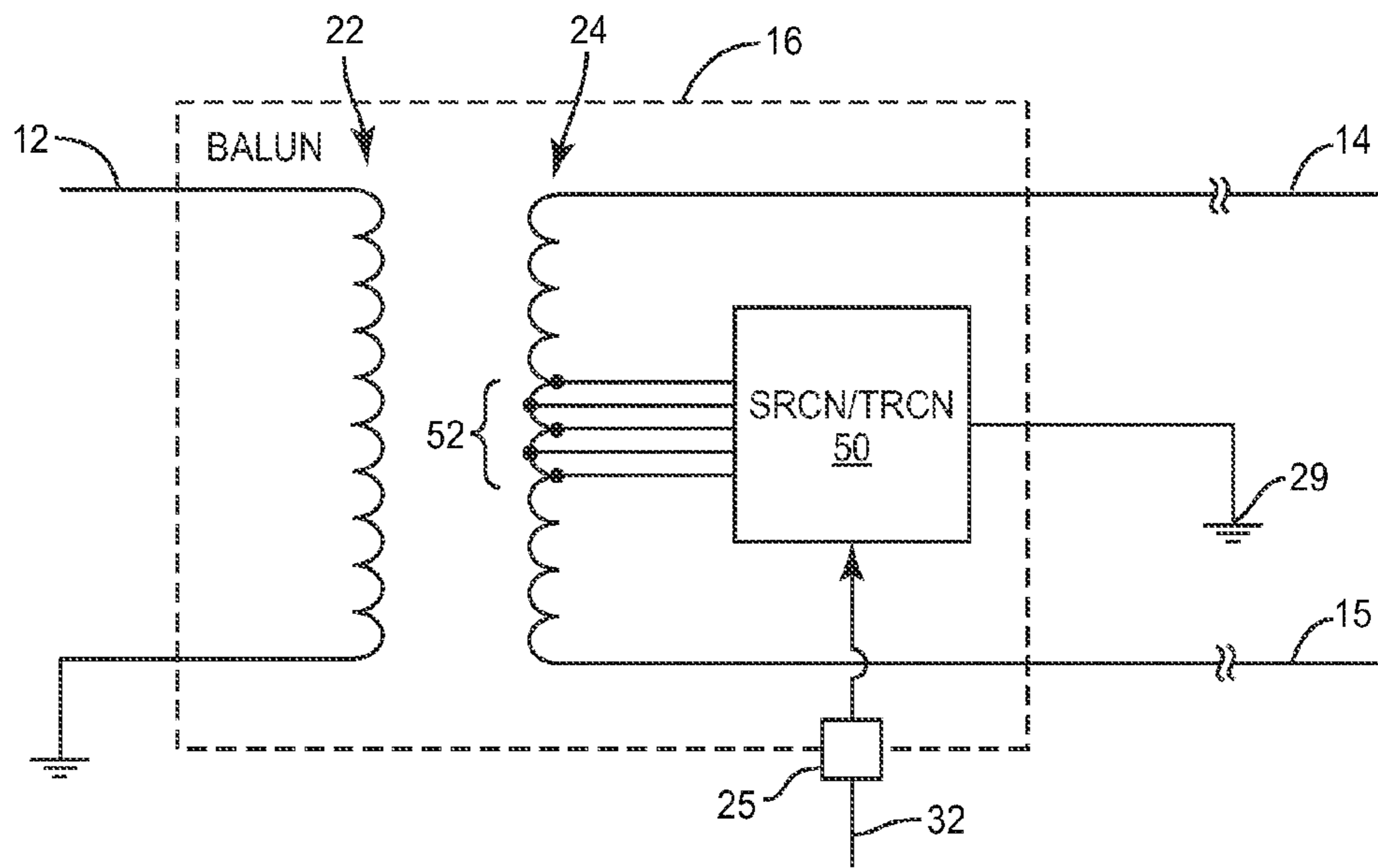

FIG. 7

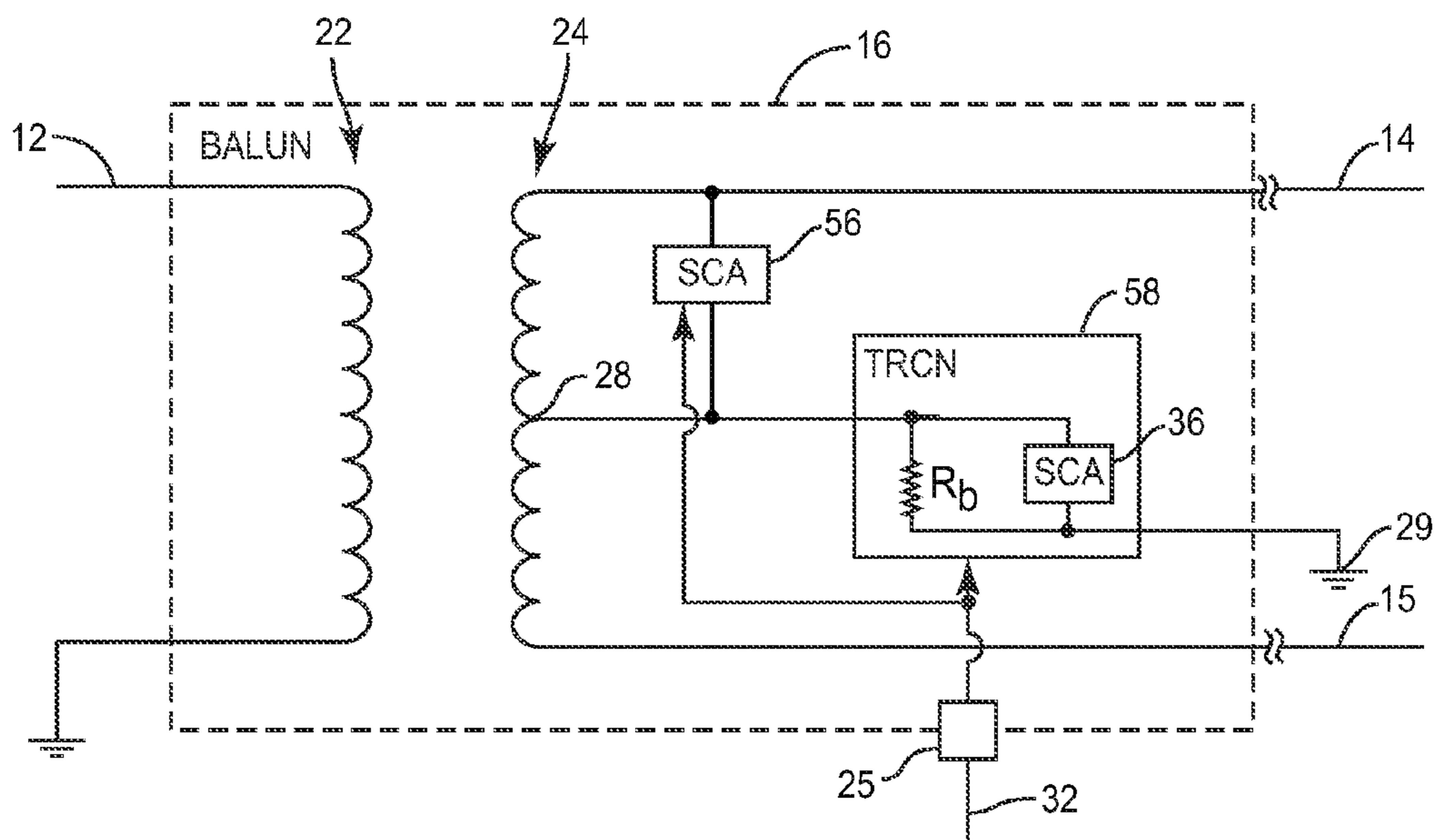

FIG. 8

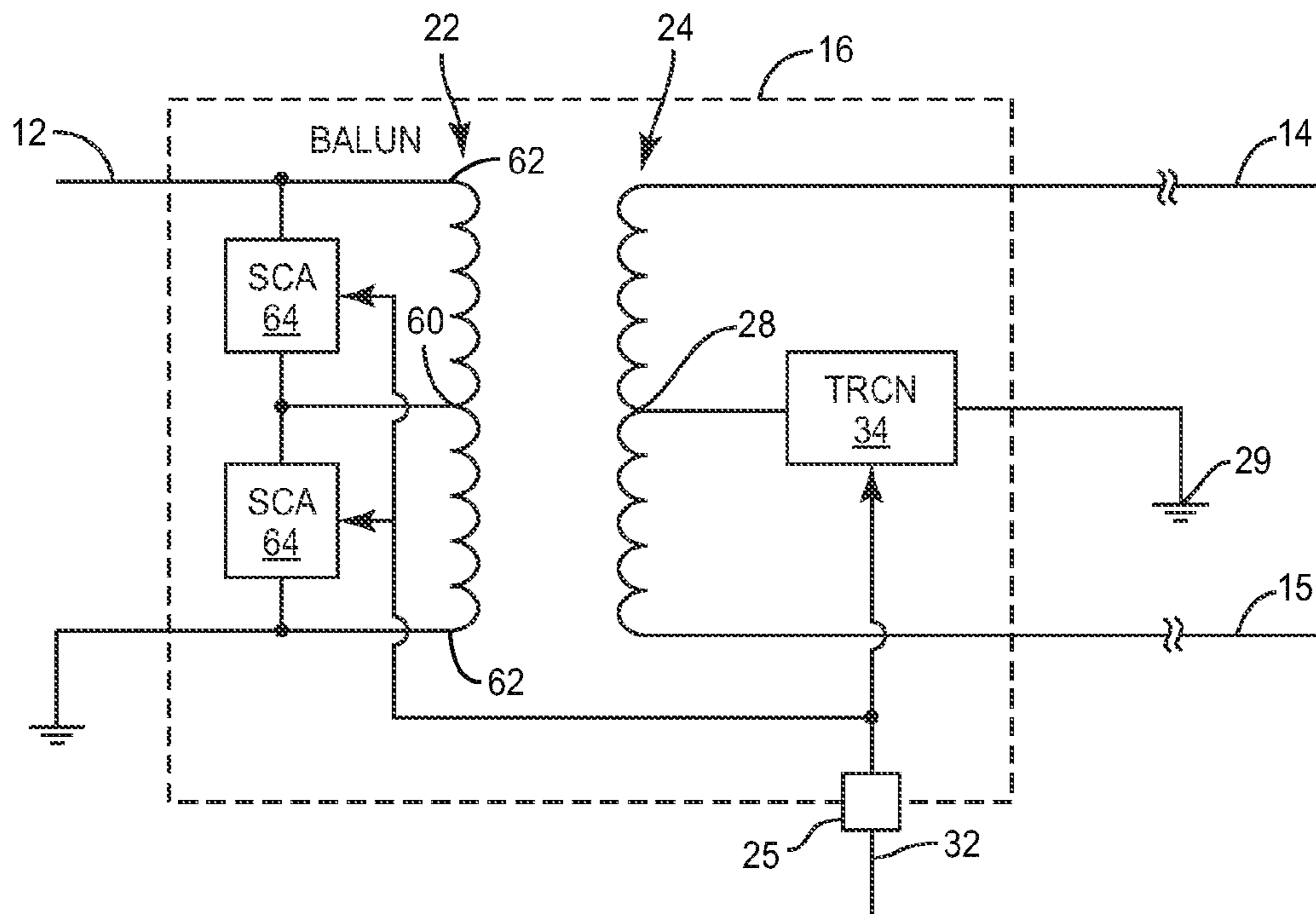

FIG. 9

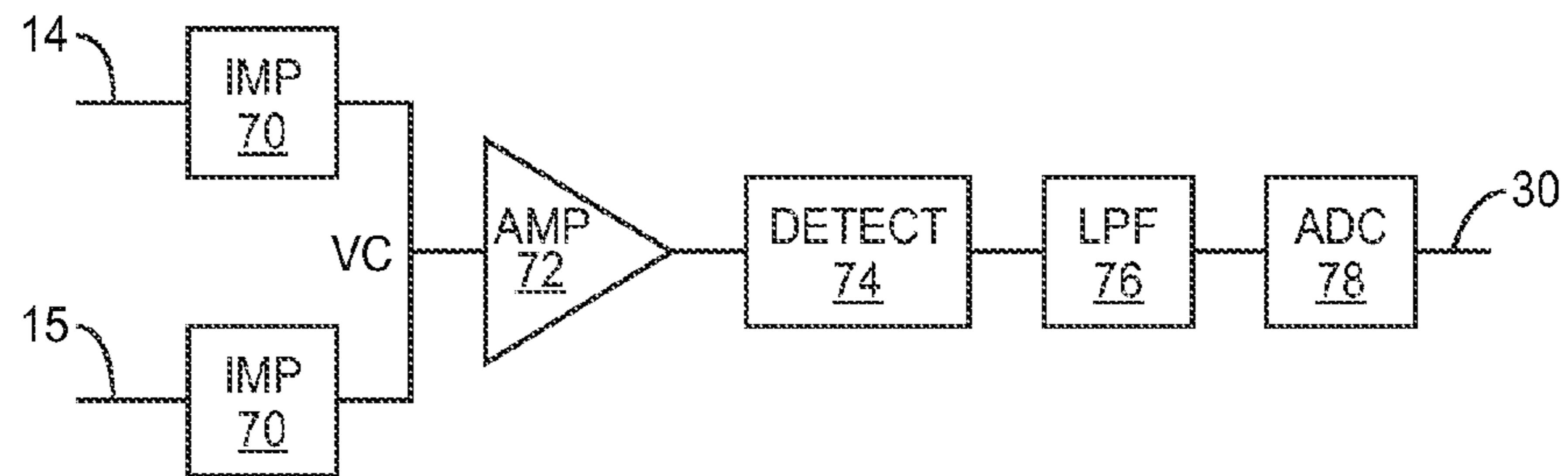

FIG. 10A

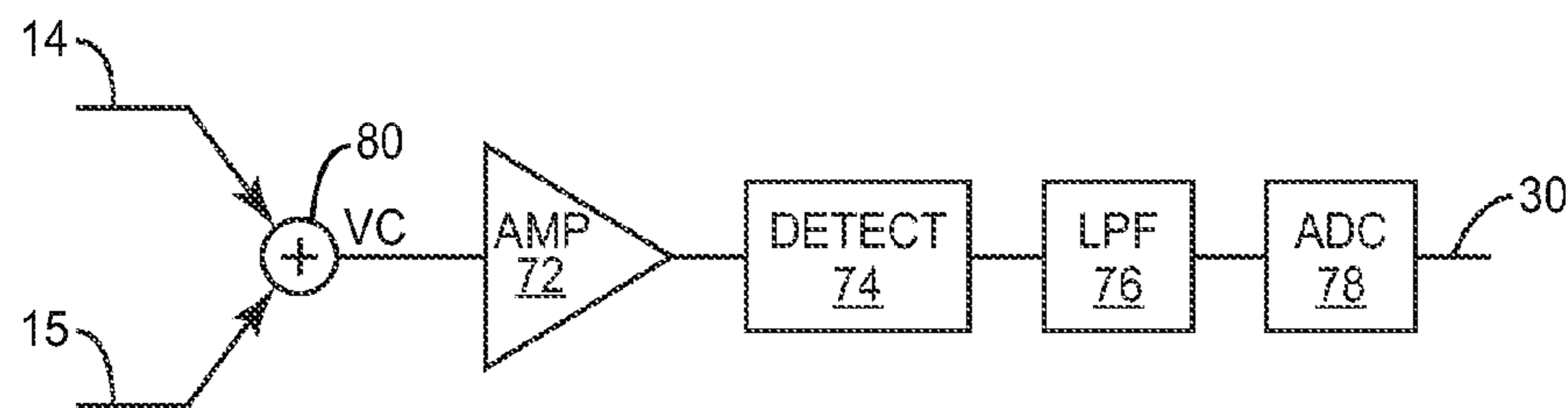

FIG. 10B

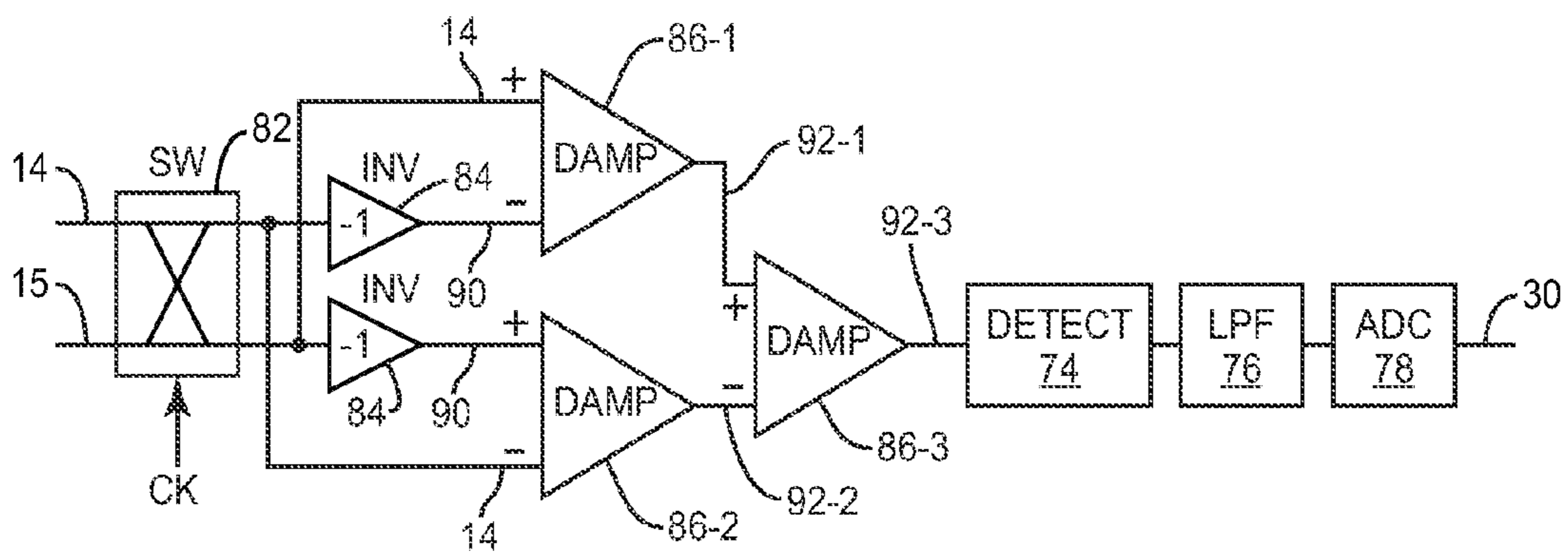

FIG. 10C

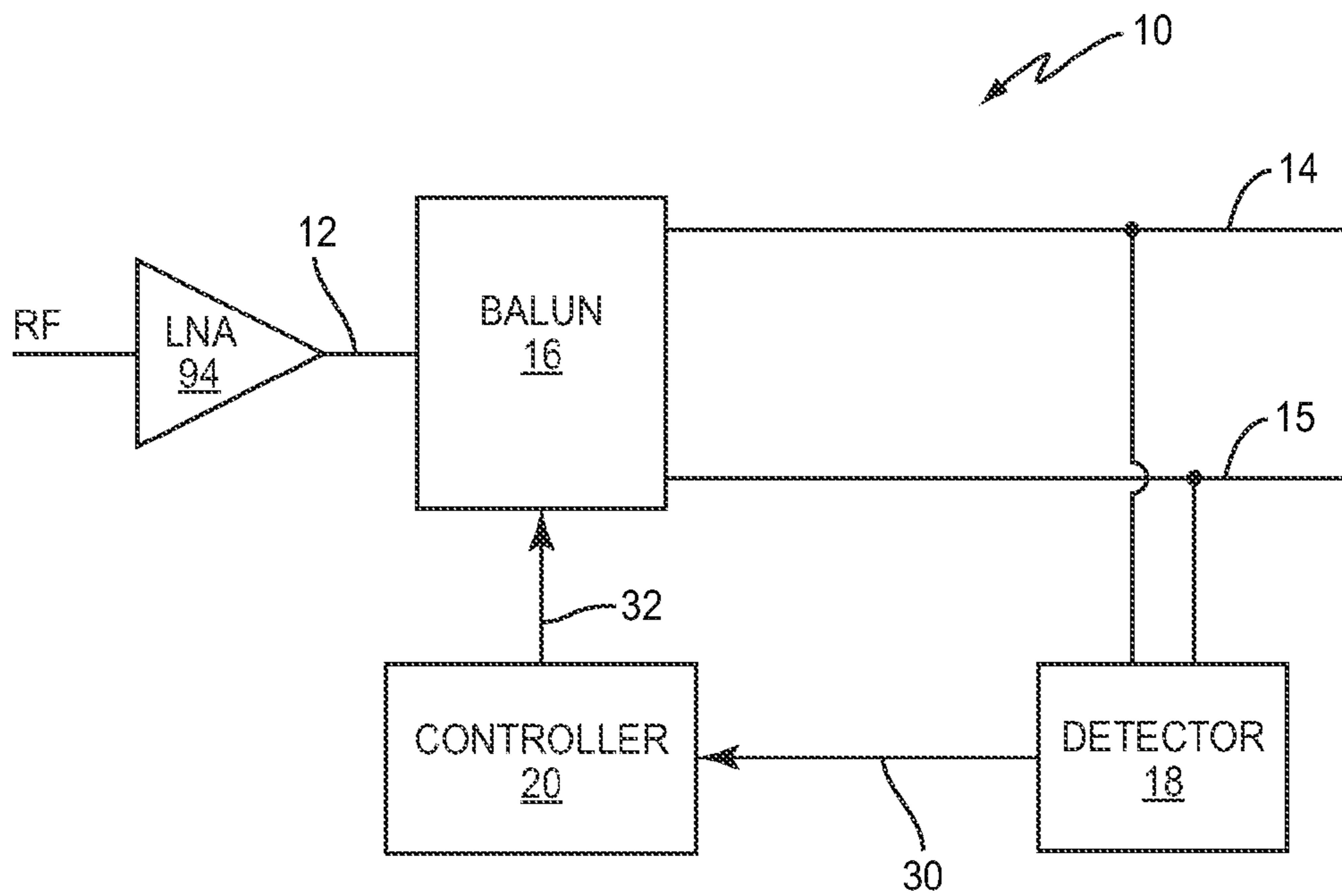

FIG. 11A

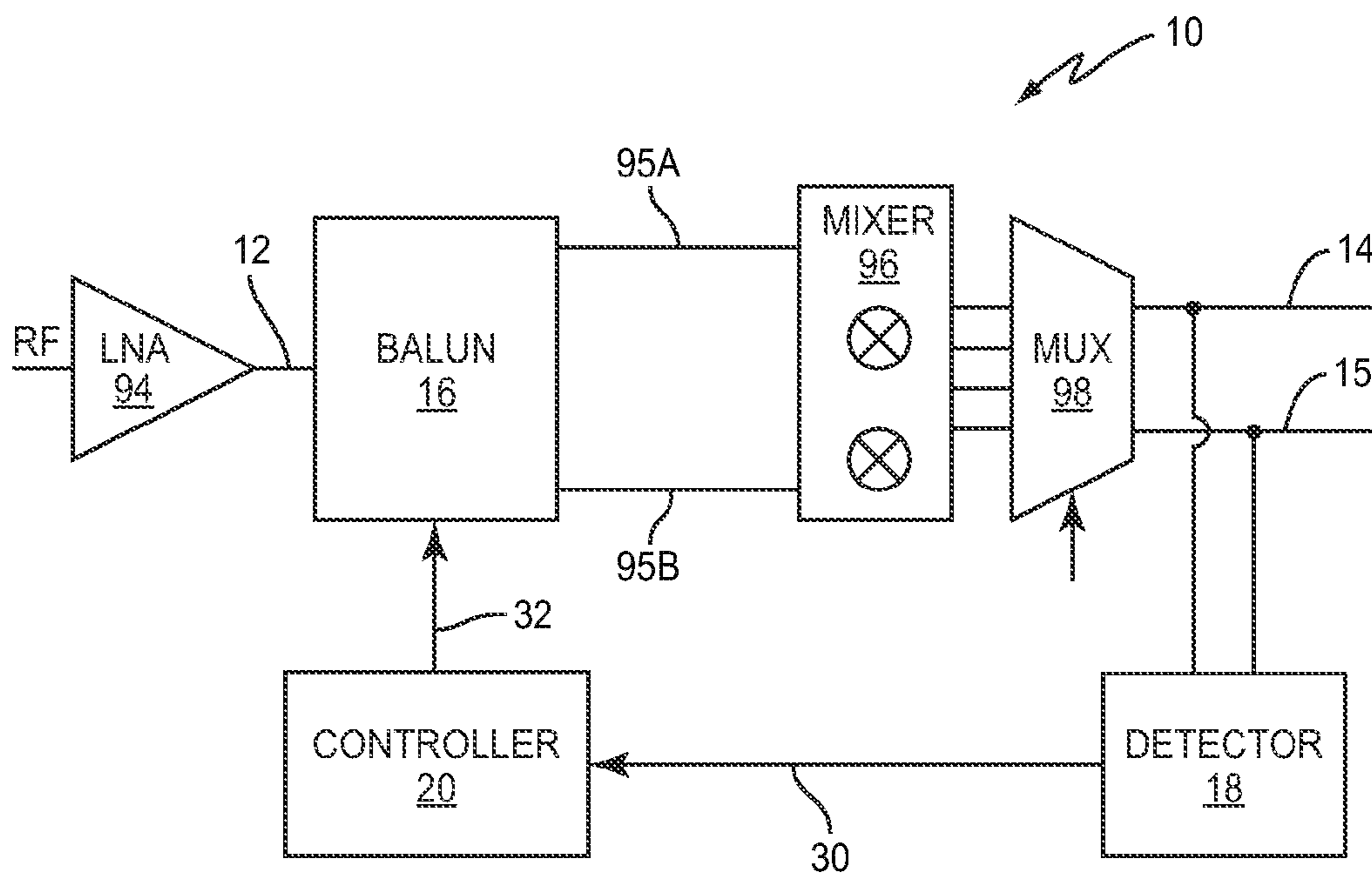

FIG. 11B

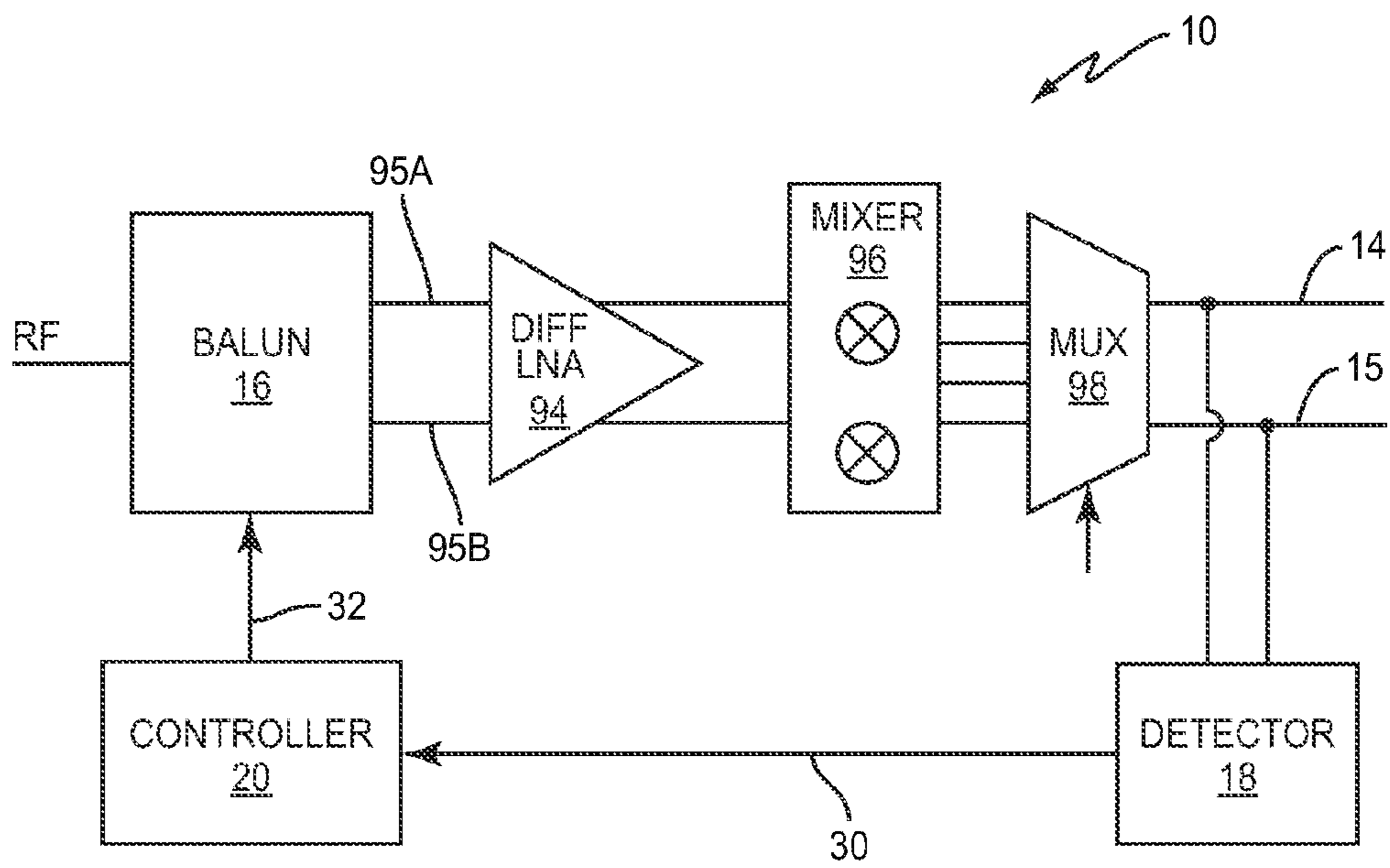
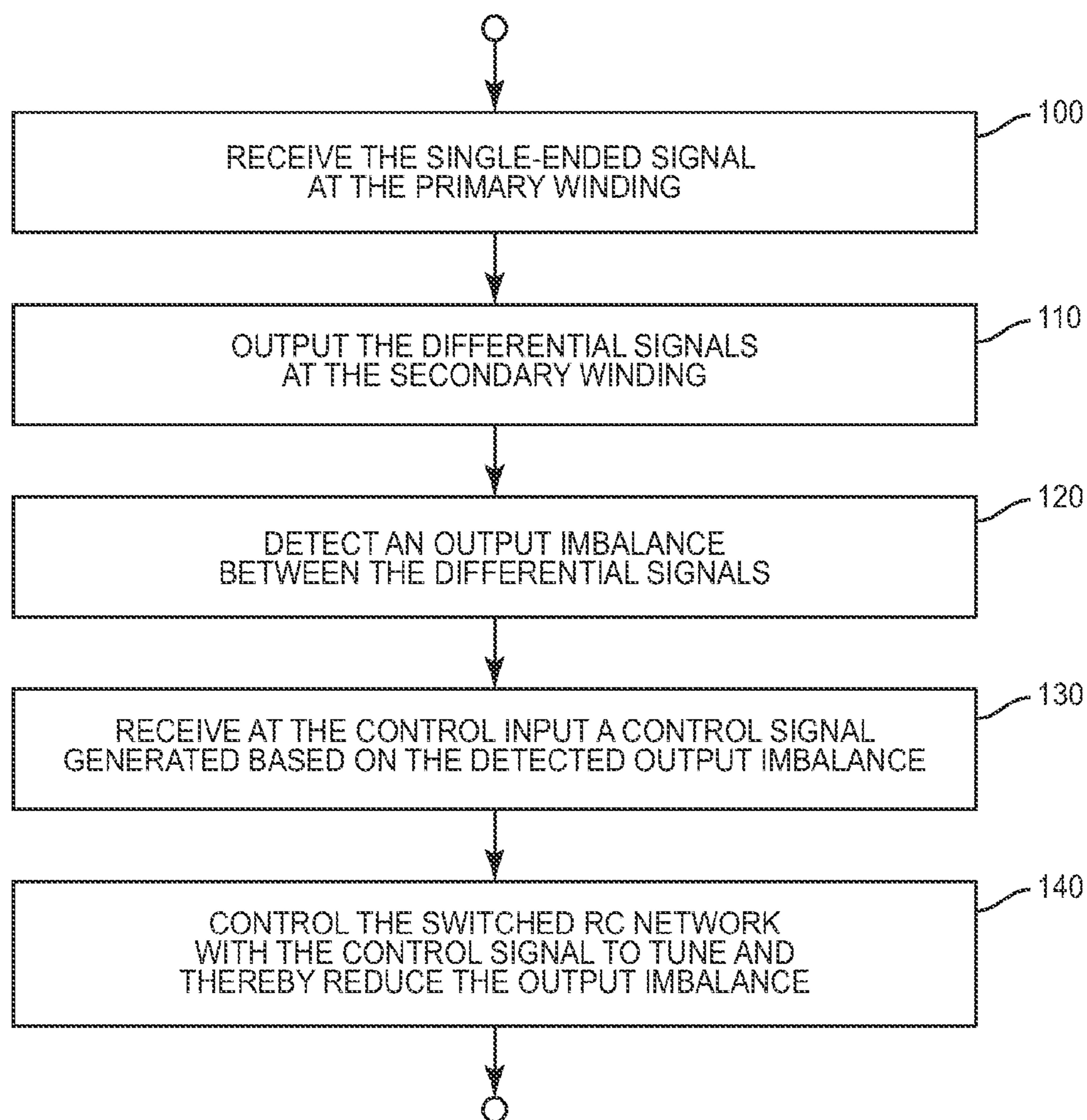

FIG. 11C

**FIG. 12**

IMBALANCE DETECTION AND REDUCTION FOR WIDEBAND BALUN

RELATED APPLICATIONS

The present application is a continuation of U.S. patent application Ser. No. 12/957,684, which was filed on Dec. 1, 2010, and is incorporated by reference herein in its entirety.

TECHNICAL FIELD

The present invention generally relates to baluns, and particularly relates to circuits and methods for detecting and reducing imbalance between differential signals generated by a balun.

BACKGROUND

Single-ended signaling approaches transmit information by sending a single-ended electrical signal over a single signal conductor. Differential signaling approaches, by contrast, transmit information by sending two complementary (i.e., differential) signals over two separate signal conductors. Single-ended signaling typically costs less, but lacks the noise rejection benefits of differential signaling. Consequently, both signaling approaches appear in common electrical circuits.

A balun converts single-ended signals to differential signals, and vice versa, and thereby enables circuits that use different signaling approaches to connect to one another (e.g., antennas and differential amplifiers). In one typical implementation of single-ended to differential signal conversion, a balun consists of a symmetric transformer that has a center tap in its secondary winding. When converting to differential signals, the transformer's primary winding receives the single-ended signal and the transformer's secondary winding generates the differential signals relative to a common reference signal present at the center tap.

Ideally, the differential signals generated by a balun are balanced in the sense that they have the same amplitudes, but opposite phases. In practice, however, achieving perfect balance between differential signals proves quite challenging, especially for a wide range of signal frequencies. Unavoidable asymmetry in the physical layout of an on-chip balun, for example, introduces imbalance between the amplitudes, phases, or both of differential signals. Process variation in the manufacture of on-chip balun components for semi-conductor chips also introduces imbalance. Further, parasitic cross-coupling capacitance between the primary winding and the second winding introduces imbalance when converting signals with high frequency.

Imbalanced differential signals significantly limit performance of wireless communication systems. As one example, the transmitter of a radio front-end employing frequency-division duplexing (FDD) sometimes produces a large amplitude leakage into the receiver. This transmit signal leakage in turn causes intermodulation distortions in the receiver, including for example second inter-modulation distortions known as IMD2. If the receiver directly down-converts the received radio signal to baseband, without first translating the received signal to an intermediate frequency, the second-order inter-modulation distortions disturb the baseband signal. The receiver can theoretically employ a balun to produce differential radio frequency signals and use differential circuits to cancel such even order distortions before they disturb

the baseband signal. However, without well balanced differential signals the differential circuits cannot completely eliminate the distortions.

SUMMARY

Teachings herein advantageously detect and reduce imbalance between differential signals generated by a balun. The teachings thereby produce well balanced differential signals even when asymmetries or process variations in the balun would otherwise result in imbalance. Notably, the teachings also produce well balanced differential signals over a wide range of signal frequencies, and are thus well suited for improving the performance of wireless communication systems.

According to some embodiments, a circuit converts a single-ended signal to differential signals that are balanced to have the same amplitude and opposite phase. The circuit includes a balance tunable balun, a detector, and a controller. The balance tunable balun is "balance tunable" in the sense that its output balance (i.e., the balance between the differential signals output by the balun) is tunable. Specifically, the balance tunable balun comprises a balun with primary and secondary windings, and further comprises a control input and a switched resistor-capacitor (RC) network. The primary winding receives the single-ended signal and the secondary winding outputs the differential signals. The control input receives a control signal and the switched RC network tunes the output balance of the balance tunable balun responsive to that control signal. The detector detects the output imbalance and the controller outputs the control signal to control the switched RC network to reduce the output imbalance.

As the balance tunable balun is an inductive device, it can of course be tuned to resonate at any required frequency by some kind of frequency tuning circuit. Note, though, that such resonance frequency tuning is distinct from the balance tuning discussed herein. In the context of balance tuning, the balance tunable balun is tuned or calibrated over a wide range of signal (i.e., working) frequencies according to the control signal. At each desired working frequency, the control signal may have a different value in order to create balanced differential outputs at that specific frequency.

A switched RC network (SCRN) as used herein refers generally to any RC network that has switched inputs, switched RC components, or both. A switched RC network that has switched RC components, but a fixed input instead of switched inputs, may more specifically be referred to herein as a "tunable" RC network (TRCN).

In one or more embodiments, for example, the secondary winding has a center tap that is connected to a signal ground via a SRCN comprising a TRCN. The controller reduces output imbalance by tuning this TRCN via the control signal. More particularly, the controller generates the control signal to direct the TRCN to selectively connect one or more resistors, and one or more capacitors, between the center tap and the signal ground.

In other embodiments, the primary winding has a plurality of primary taps (m) surrounding a primary port connected to a signal ground. Also, the secondary winding has a center tap. The balance tunable balun includes an SRCN that selectively connects one of the primary winding's taps (as inputs to the SRCN) to the secondary winding's center tap via an RC network, responsive to the control signal. In some embodiments, this RC network remains fixed, such that the SRCN only includes a switched input. In other embodiments, the RC network may comprise a TRCN, such that the SRCN includes both a switched input and switched RC components.

3

Embodiments including either a TRCN or an SRCN reduce detected imbalance particularly well for imbalance attributable to balun asymmetry or process variation. However, for imbalance attributable to parasitic capacitance at high frequencies, embodiments that include both a TRCN (as a first SRCN) and an SRCN (as a second SRCN) offer enhanced imbalance reduction. By including both a TRCN and an SRCN, these embodiments provide both coarse and fine tuning of the output imbalance. The controller may, for example, control the SRCN for coarsely tuning the output imbalance and control the TRCN for finely tuning the output imbalance.

Alternative embodiments provide substantially equivalent imbalance reduction, even for imbalance attributable to parasitic capacitance. Specifically, the secondary winding's has a plurality of candidate center taps. These candidate center taps are each a "candidate" for being the electrical center of the secondary winding. The controller generates the control signal to selectively connect one of these candidate center taps, via an SRCN, to the signal ground. This SRCN may comprise only a switched input, or both a switched input and switched RC components.

Still other embodiments reduce imbalance without taking any taps from the primary winding, and without taking any taps from the secondary winding other than one center tap. In these embodiments, the controller reduces imbalance not only by controlling an SRCN connected to the secondary winding's center tap, but also by controlling one or more controllable capacitances introduced to the balun. For example, a controllable capacitance may be introduced between one of the secondary winding's secondary ports and the center tap. By controlling this controllable capacitance, in cooperation with controlling the SRCN the controller reduces output imbalance.

In one or more embodiments, the circuit described above may comprise part of a radio receiver, for improving the performance of a wireless communication system. In these embodiments, the circuit may operate solely on radio frequency signals, to simply reduce imbalance introduced by the balun. In other embodiments, though, the circuit may also operate on baseband signals, to reduce imbalance introduced by the balun as well as imbalance introduced by other receiver components (e.g., a mixer).

Of course, the present invention is not limited to the above features and advantages. Indeed, those skilled in the art will recognize additional features and advantages upon reading the following detailed description, and upon viewing the accompanying drawings.

BRIEF DESCRIPTION OF THE DRAWINGS

FIG. 1 is a block diagram of a circuit configured to convert a single-ended signal to differential signals, according to some embodiments of the present invention.

FIGS. 2A-2B are graphs illustrating exemplary control of a balance tunable balun for reducing imbalance detected between the differential signals.

FIG. 3 is a block diagram of a balance tunable balun that includes a switched resistor-capacitor network according to one embodiment.

FIG. 4 is a block diagram of a switched resistor-capacitor network that comprises a tunable resistor-capacitor network (TRCN) according to one or more embodiments.

FIG. 5 is a block diagram of a balance tunable balun that includes a switched resistor-capacitor network (SRCN) according to another embodiment.

4

FIG. 6 is a block diagram of a balance tunable balun that includes both a TRCN and a SRCN according to one or more embodiments.

FIG. 7 is a block diagram of a balance tunable balun that includes a SRCN according to one or more embodiments.

FIG. 8 is a block diagram of a balance tunable balun that includes a controllable capacitance connected from one output port to the center tap, according to one or more embodiments.

FIG. 9 is a block diagram of a balance tunable balun that includes two controllable capacitances connected from respective primary ports to the primary winding's center tap, according to various embodiments.

FIGS. 10A-10C are block diagrams of alternative embodiments of a detector.

FIGS. 11A-11C are block diagrams of alternative embodiments of a circuit that comprises part of a radio receiver.

FIG. 12 is a logical flow diagram of a method for converting a single-ended signal to differential signals, according to some embodiments of the present invention.

DETAILED DESCRIPTION

FIG. 1 illustrates a circuit 10 configured to convert a single-ended signal 12 to differential signals 14 and 15 that are balanced to have the same amplitudes and opposite phases. The circuit 10 includes a balance tunable balun 16, a detector 18, and a controller 20.

The balance tunable balun 16 has a primary winding 22, a secondary winding 24, a control input 25, and a switched resistor-capacitor (RC) network 26. The primary and secondary windings 22, 24 are magnetically coupled together. The primary winding 22 receives the single-ended signal 12 and the secondary winding 24 outputs the differential signals 14 and 15. The control input 25 receives a control signal 32, and the switched RC network 26 tunes an output imbalance of the balance tunable balun 16 responsive to this control signal 32. The output imbalance is an imbalance between the balance tunable balun's outputs; that is, an imbalance between the differential signals 14 and 15. The detector 18 detects this output imbalance and the controller 20 generates the control signal 32 to control the switched RC network 26 to reduce that output imbalance.

In some embodiments, for example, the detector 18 generates an error signal 30 that indicates the residual error of the output imbalance between the differential signals 14 and 15. Responsive to this error signal 30, the controller 20 generates an control signal 32 that controls the switched RC network 26 as needed to reduce the residual error of the output imbalance indicated by the error signal 30, e.g., to below some predetermined acceptable imbalance threshold. In some embodiments, the controller 20 generates the control signal 32 as a multi-bit control signal. In this case, the control input 25 comprises a binary vector input that receives the multi-bit control signal 32.

Regardless of the particular type of the control signal 32, the controller's generation of that control signal 32 and corresponding control of the switched RC network 26 affects the balance between the differential signals 14 and 15. This is because the control signal 32 effectively adjusts a reference point of the differential signals 14 and 15. The graphical example in FIGS. 2A-2B illustrates this concept well. In FIG. 2A, the origin O in the complex coordinate system (x, jy) defines the reference point of the differential signals. Typically, this reference point is signal ground. Each differential signal 14 and 15, represented by respective vectors A and B, has an amplitude and phase defined relative to this origin O.

5

When the reference point is defined at the origin O as shown, the differential signals **14** and **15** are imbalanced because the vectors A and B do not have exactly the same amplitudes or exactly opposite phases relative to the origin O.

The detector **18** described above detects this imbalance and the controller **20** reduces the imbalance by controlling the switched RC network **26**. Specifically, in controlling the switched RC network **26**, the controller **20** effectively creates an offset. As a result, the output differential signal **14** and **15** becomes balanced. This equivalently translates the complex coordinate system (x, jy) with origin O into a new complex coordinate system (x', jy') with new origin O'. The controller **20** thereby adjusts the reference point of the differential signals **14** and **15** so that, in this new complex coordinate system (x', jy'), the differential signals **14** and **15** are better balanced (i.e., so that the vectors A and B, when translated into A' and B' in the new complex coordinate system (x', jy'), more closely approximate vectors that have the same amplitudes and opposite phase relative to the new origin O').

FIGS. 2A-2B illustrate a simple, ideal case where the controller **20** perfectly balances the differential signals. The controller **20** adjusts the reference point of the differential signals **14** and **15** by a vector C. This translates point c in the complex coordinate system (x, jy) to the origin O' in the new complex coordinate system (x', jy'), and correspondingly translates the vectors A and B in the complex coordinate system (x, jy) to the vectors A' and B' shown in FIG. 2B. These vectors A' and B' have exactly the same amplitudes and exactly opposites relative to the new origin O'.

As explained in more detail below, a switched RC network (SRCN) **26** as used herein refers generally to any RC network that has switched inputs, switched RC components, or both. A switched RC network **26** that has switched RC components, but a fixed input instead of switched inputs, may more specifically be referred to herein as a "tunable" RC network (TRCN).

FIG. 3 illustrates an embodiment where the switched RC network **26** comprises a TRCN **34** (shown here as a two-port TRCN). The secondary winding **24** in these embodiments has a center tap **28** that is connected to a signal ground **29** via the tunable RC network **34**. The controller **20** reduces imbalance by tuning this tunable RC network **34** via the control signal **32**. More particularly, the controller **20** tunes the tunable RC network **34** to have any impedance $R \pm j\sigma$, where R represents any one of a plurality of discrete resistances with which the network **34** is pre-configured and σ represents any one of a plurality of discrete reactances with which the network **34** is pre-configured. In one or more embodiments, for example, the tunable RC network **34** includes switched resistor and capacitor arrays that are pre-configured with particular resistors and capacitors, respectively. FIG. 4 shows an example of these embodiments.

In FIG. 4, as an example, the two-port tunable RC network **34** comprises a switched capacitor array (SCA) **36** and a switched resistor array (SRA) **38**. The switched capacitor array **36** includes a plurality of capacitors **40** and is configured to selectively connect one or more of these capacitors **40** to the center tap **28** responsive to the control signal **32**. The switched capacitor array **36**, for example, includes a plurality of switches **42** that each selectively connect a corresponding one of the capacitors **40** to the center tap **28** in accordance with the control signal **32**. Optionally, a varactor capacitor can also be used in parallel with the selectively connected capacitors.

Similarly, the switched resistor array **38** includes a plurality of resistors and is configured to selectively connect one or more of those resistors to the center tap **28** responsive to the

6

control signal **32**. For ease of illustration, details of the switched resistor array **38** have been omitted from FIG. 4, but the array **38** may be implemented in much the same way as the switched capacitor array **36** with resistors in place of the capacitors **40**.

FIG. 5 illustrates other embodiments of the balance tunable balun **16** that include a switched RC network in a more general sense. In these embodiments, the primary winding **22** has a plurality of primary taps **46** surrounding a primary port **48** connected to a signal ground **11**. The balance tunable balun **16** comprises a switched RC network (SRCN) **44** that selectively connects one of these primary taps **46** (as inputs to the SRCN **44**) to a center tap **28** of the secondary winding **24** via an RC network (not shown), responsive to the control signal **32**. In embodiments where the primary winding **22** has m taps **46** surrounding the primary port **48**, for example, the SRCN **44** may comprise an m-to-1 switch that switches the input of the SRCN **44** between different ones of those m taps **46**. The tap selected by the m-to-1 switch is applied to an RC network.

In some embodiments, the RC network remains fixed, such that the SRCN **44** connects a primary tap to the center tap **28** via the same RC components regardless of the control signal **32** and regardless of which primary tap **46** is selected; that is, the SRCN **44** only includes a switched input. In other embodiments, the RC network inside the SRCN **44** may comprise a TRCN similar to that illustrated in FIG. 4, such that the control signal **32** not only selects between different primary taps **46**, but also tunes the TRCN; that is, the SRCN **44** includes both a switched input and switched RC components.

The balun embodiments illustrated in FIGS. 3-5 reduce imbalance particularly well for imbalance attributable to balun asymmetry or process variation. However, for imbalance attributable to parasitic capacitance at high frequencies, embodiments illustrated in FIG. 6 offer enhanced imbalance reduction. The balance tunable balun **16** in FIG. 6 embodiments includes both a TRCN **34** (as a first SRCN) and a SRCN **44** (as a second SRCN) in order to provide coarse and fine tuning of the output imbalance. In one embodiment, for example, the controller **20** controls the SRCN **44** for coarsely tuning the output imbalance. The controller **20** may, for example, control the SRCN's selection of different primary taps **46** for making coarse center tap impedance adjustments. In this case, the controller **20** controls the TRCN **34** for finely tuning the output imbalance. In other embodiments, the roles of the TRCN **34** and the SRCN **44** may be switched, providing coarse tuning via the TRCN **34** and fine tuning via the SRCN **44**.

FIG. 7 illustrates alternative balance tunable balun **16** embodiments to FIG. 6 that provide substantially equivalent imbalance reduction, even for imbalance attributable to parasitic capacitance. Rather than tapping the primary winding **22**, the embodiments tap the secondary winding **24** with a SRCN **50** to a signal ground **29**. Specifically, the secondary winding **24** in these embodiments comprises one of a plurality of so-called candidate center taps **52** that surround the geometric center of the secondary winding **24**. These candidate center taps **52** are each a "candidate" for being the electrical center of the secondary winding **24**. The controller **20** generates the control signal **32** to selectively connect one of these candidate center taps **52**, via the SRCN **50**, to the signal ground **29**. Similar to the SRCN **44** in FIG. 6, the SRCN **50** may comprise only a switched input, or both a switched input and switched RC components.

FIG. 7 shows five candidate center taps **52**, but other embodiments may include any number of candidate center taps **52** greater than one. A greater number of candidate center taps **52** provides a better approximation to the secondary

winding's electrical center over a greater range of operating scenarios, e.g., over a greater range of frequencies. Taking at least some candidate center taps **52** at locations other than the beginning or end of turns (i.e., at fractions of a turn) may also provide better approximations.

Other alternative embodiments reduce imbalance without taking any taps from the primary winding **22**, and without taking any taps from the secondary winding **24** other than the one center tap **28** consistently illustrated in FIGS. 1-7. In these embodiments, the controller **20** reduces imbalance not only by controlling the reference point of the differential signals **14** and **15**, but also by controlling the amplitude of one of the differential signals **14** and **15**. Consider again the simple example illustrated back in FIGS. 2A-2B. In that example, the differential signal **14** and **15** represented by the vector A had a greater amplitude than the differential signal **14** and **15** represented by the vector B. The controller **20** thus reduces imbalance by reducing the amplitude of the vector A differential signal **14** and **15**, in cooperation with adjusting the reference point (i.e., the origin O) of the differential signals **14** and **15**.

FIG. 8 illustrates one such embodiment of a balance tunable balun **16**. In FIG. 8, similar to FIG. 3, the balance tunable balun **16** includes an SRCN that comprises a TRCN **58**. The balance tunable balun **16**, however, also includes a controllable capacitance connected from a secondary port **54** of the secondary winding **24** to the center tap **28**. As shown, for example, the balance tunable balun **16** includes an SCA **56** connected from the secondary port **54** to the center tap **28**. Regardless, the secondary winding **24** outputs one of the differential signals **14** and **15** at secondary port **54**; this differential signal **14** or **15** has an amplitude that depends on the capacitance of the SCA **56**. The controller **20** thereby reduces output imbalance by controlling the SCA **56** (to adjust the amplitude of one differential signal **14** or **15**) and the TRCN **58** (to adjust the reference point of the differential signals **14** and **15**).

Although the controller **20** in some embodiments tunes the output imbalance by controlling a TRCN **34** like the one shown in FIG. 4, the controller **20** in other embodiments controls the TRCN **58** shown in FIG. 8. The TRCN **58** in FIG. 8 includes the same SCA **36** as the TRCN **34** in FIG. 4, but does not include the SRA **38**. Instead of the SRA **38**, which selectively connected any one of a plurality of resistors to the center tap **28** responsive to the control signal **32**, the TRCN **58** includes a single bias resistor R_b that remains statically connected to the center tap **28** irrespective of the control signal **32**. The single bias resistor R_b reduces the complexity of the TRCN **58** in FIG. 8 as compared to the TRCN **34** in FIG. 4 with little or no degradation to the circuit's imbalance reduction performance.

FIG. 9 illustrates an alternative balance tunable balun **16** embodiment to FIG. 8 that provides substantially equivalent imbalance reduction. Like the embodiment in FIG. 8, the embodiment in FIG. 9 reduces imbalance by controlling the reference point of the differential signals **14** and **15**, as well as controlling the amplitude of one of the differential signals **14** or **15**. However, rather than controlling the amplitude of one of the differential signals **14** and **15** by controlling the controllable capacitance of a secondary port, the embodiment in FIG. 9 controls controllable capacitances of primary ports.

More particularly, the primary winding **22** in FIG. 9 has a center tap **60** and two primary ports **62**. Again, similar to FIG. 3, the balance tunable balun **16** includes an SRCN that comprises a TRCN **58**. The balance tunable balun **16** further comprises two controllable capacitances connected from each respective port **62** to the primary winding's center tap

60. As shown, for example, the balance tunable balun **16** includes SCAs **64** connected from each primary port **62** to center tap **60**. Regardless, one of the differential signals **14** and **15** has an amplitude that depends on the capacitances of the SCAs **64**. The controller **20** thereby reduces output imbalance by controlling the SCAs **64** (to adjust the amplitude of one differential signal **14** or **15**) and the TRCN **34** (to adjust the reference point of the differential signals **14** and **15**).

FIGS. 10A-10C illustrate various embodiments of the detector **18** for detecting imbalance between the differential signals **14** and **15**. In FIG. 10A, the detector **18** includes two impedances **70**, an amplifier **72**, a detector **74**, a low pass filter (LPF) **76**, and an analog-to-digital converter (ADC) **78**. The two impedances **70** (e.g., resistors) connect at one end to respective differential signals **14** and **15** and join at the other end to generate a voltage v_c . The impedances **70** generate a voltage v_c of approximately 0 V if the differential signals **14** and **15** are balanced with the same amplitudes but opposite phases. However, the impedances **70** generate a voltage v_c greater than 0 V if the differential signals **14** and **15** are imbalanced; the greater the voltage v_c , the greater the residual error of the imbalance. The amplifier **72**, detector **74**, LPF **76**, and ADC **78** amplify, detect, filter, and convert this voltage v_c into a digital error signal **30** that indicates the residual error of the imbalance between the differential signals. The detector **74** may comprise an amplitude detector, a power detector, an envelope detector, or the like for detecting the amplified voltage v_c . Also, as shown in FIG. 10B, the impedances **70** may be replaced by an adder **80** to equivalently generate voltage v_c .

In FIG. 10C, the detector **18** still includes detector **74**, LPF **76**, and ADC **78**. Instead of impedances **70** or adder **80**, and instead of amplifier **72**, the detector **18** includes a switch **82**, two inverters **84**, and three differential amplifiers **86-1**, **86-2**, and **86-3**. The switch **82** includes two input ports and two output ports. The input ports receive respective ones of the differential signals **14** and **15**. The output ports each output one of those differential signals **14** and **15** unchanged. Which particular differential signal **14** and **15** a particular output port outputs, though, varies periodically in accordance with a clock signal Ck. Thus, the switch **82** periodically swaps the differential signals **14** and **15** with respect to its output ports. In doing so, the switch **82** eliminates any possible error in detecting imbalance that might be attributable to mismatch between other components in the detector **74**, such as the pair of inverters **84**.

Each inverter **84** inverts the differential signal **14** output by a respective output port of the switch **82**. In doing so, each inverter **84** effectively generates an inverted version **90** of that differential signal **14** and **15** that has the same amplitude, but opposite phase.

During any given clock period, differential amplifier **86-1** amplifies the difference between a first differential signal **14** and **15** and the inverted version **90** of a second differential signal **14** and **15**, and thereby generates a first amplified difference signal **92-1**. Conversely, differential amplifier **86-2** amplifies the difference between the second differential signal **14** and **15** and the inverted version **90** of the first differential signal **14** and **15**, and thereby generates a second amplified difference signal **92-2**. Differential amplifier **86-3** amplifies the difference between this second amplified difference signal **92-2** and the first amplified difference signal **92-1**, to thereby generate a third amplified difference signal **92-3**. The detector **74**, LPF **76**, and ADC **78** detect, filter, and convert this third amplified difference signal **92-3** into a digital error signal **30** that indicates the residual error of the imbalance between the differential signals **14** and **15**.

During the next clock period, the switch swaps the differential signals **14** and **15** with respect to the switch's output ports, which correspondingly swaps the roles of differential amplifiers **86-1** and **86-2**. Again, this swap eliminates any possible error in detecting imbalance that might be attributable to mismatch between the inverters **84**, or between the differential amplifiers **86-1** and **86-2**.

Regardless of the particular manner in which the detector **18** generates the error signal **30**, the controller **20** evaluates that error signal **30** and dynamically controls the SRCN **26** as needed to reduce the residual error of the imbalance indicated by the error signal **30**. In some embodiments, the controller **20** controls the SRCN **26** over several control periods, controlling the SRCN **26** in any given control period based on an evaluation of whether control of the SRCN **26** in a previous control period increased or decreased the residual error of imbalance. For example, if the controller **20** controlled the SRCN **26** to increase the center tap impedance in a previous control period by increasing resistance, and that increase in resistance actually increased imbalance, the controller **20** may decrease resistance in subsequent control periods in order to decrease the imbalance.

As imbalance significantly limits performance of wireless communication systems, the circuit **10** described above advantageously comprises part of a radio receiver in one or more embodiments. Consider first the embodiment shown in FIG. **11A**. In FIG. **11A**, a low-noise amplifier (LNA) **94** amplifies a radio frequency (RF) signal received by one or more antennas associated with the radio receiver, in order to generate the single-ended signal **12**. The single-ended signal **12** thus comprises a radio frequency (RF) signal. The balance tunable balun **16** converts this single-ended signal **12** into differential radio frequency signals **14** and **15**. The detector **18** detects imbalance between the differential radio frequency signals **14** and **15**, and the controller reduces the detected imbalance by dynamically controlling the SRCN **26**.

Although the embodiment in FIG. **11A** certainly reduces imbalance introduced by the balun **16**, the radio receiver may include other components that also introduce imbalance. The circuit **10** in other embodiments advantageously reduces imbalance introduced by these other receiver components as well. Consider the embodiment shown in FIG. **11B**.

In FIG. **11B**, the circuit **10** reduces imbalance introduced by the balun **16**, as well as imbalance introduced by a mixer **96** included in the radio receiver chain. More particularly, the balance tunable balun **16** converts the single-ended signal **12** into differential radio frequency signals **95A** and **95B**. These differential radio frequency signals **95A** and **95B** may be imbalanced, but unlike the embodiment in FIG. **11A** the detector **18** does not detect that imbalance. Instead, the mixer **96** (in cooperation with multiplexer **98**) first converts these differential radio frequency signals **95A** and **95B** into differential baseband signals **14** and **15**, and the detector **18** detects imbalance between those differential baseband signals **14** and **15**. Responsive to imbalance between the differential baseband signals **14** and **15** rather than the differential radio frequency signals **95A** and **95B**, the circuit **10** reduces imbalance introduced by both the balun **16** and the mixer **96**.

Those skilled in the art will of course appreciate that the above embodiments represent non-limiting examples of the present invention. As one example, FIG. **11B** illustrates the LNA **94** as converting the received RF signal into the single-ended signal **12** before that signal **12** is input into the balance tunable balun **16**. In other embodiments, like the one shown in FIG. **11C**, the received RF signal may be input into the balance tunable balun **16** directly, such that the balance tunable balun **16** converts the received RF signal into differential RF

signals **95A** and **95B**. In these embodiments, differential LNA **94** amplifies the differential RF signals **95A** and **95B** before they are input into the mixer **96**. The differential baseband signals **14** and **15** at the output of the multiplexer MUX **98** are selected from the quadrature different outputs of mixer **96** by setting a control bit input to the MUX **98**. Thus, in this case, the feedback loop includes the balance tunable balun **16**, differential LNA **94**, mixer **96**, detector **18**, and controller **20**. Any imbalance in the signal path from RF input to mixer outputs, due to process variation or design asymmetry, can be compensated by adjusting the balance tunable balun **16**, the balance control of the mixer **96**, or most likely in practice both. Any or all of these adjustments may be facilitated through control signal **32**. The balance control of the mixer **96** can be done in many ways, such as by adjusting the LO clock output level, mixer conversion gain, etc, so that the even order distortions, like IM2, are minimized.

As another example, the above description may have been simplified in a number of respects for explanatory purposes. Indeed, the description above may have conveniently omitted one or more balun components that, while present in many known balun implementations, do not affect imbalance between the differential signals **14** and **15**. Voltage sources for imposing a DC bias to the balance tunable balun **16**, for instance, do not affect imbalance and have been omitted.

In view of the above modifications and variations, those skilled in the art will appreciate that the circuit **10** generally performs the processing illustrated in FIG. **12** for converting a single-ended signal **12** to differential signals **14** and **15** that are balanced to have the same amplitudes and opposite phases. In FIG. **12**, processing includes receiving the single-ended signal **12** at the primary winding **22** of the balance tunable balun **16** (Block **100**). Processing further includes outputting the differential signals **14** and **15** at the secondary winding **24** (Block **110**). Processing also includes detecting an output imbalance between the differential signals **14** and **15** (Block **120**) and receiving at the control input **25** a control signal **32** generated based on that detected output imbalance (Block **130**). Processing finally includes controlling the switched RC network **26** with the control signal **32** to tune and thereby reduce the output imbalance (Block **140**).

Those skilled in the art will further appreciate that the various "circuits" described may refer to a combination of analog and digital circuits, and/or one or more processors configured with software stored in memory and/or firmware stored in memory that, when executed by the one or more processors, perform as described above. One or more of these processors, as well as the other digital hardware, may be included in a single application-specific integrated circuit (ASIC), or several processors and various digital hardware may be distributed among several separate components, whether individually packaged or assembled into a system-on-a-chip (SoC).

Thus, those skilled in the art will recognize that the present invention may be carried out in other ways than those specifically set forth herein without departing from essential characteristics of the invention. The present embodiments are thus to be considered in all respects as illustrative and not restrictive, and all changes coming within the meaning and equivalency range of the appended claims are intended to be embraced therein.

What is claimed is:

1. A circuit configured to convert a single-ended signal to differential signals that are balanced to have the same amplitudes and opposite phases relative to a reference point of the differential signals, the circuit comprising:

11

a balance tunable balun comprising:

- a primary winding configured to receive the single-ended signal;
- a secondary winding configured to output the differential signals;
- a control input configured to receive a control signal;
- a switched resistor-capacitor (RC) network configured to effectively control the reference point of the differential signals responsive to the control signal;

a detector configured to detect an output imbalance of the balance tunable balun, the output imbalance comprising an imbalance between the differential signals; and

a controller configured to generate the control signal to control the switched RC network to effectively adjust the reference point of the differential signals as needed to reduce the output imbalance detected by the detector.

2. The circuit of claim 1, wherein the switched RC network comprises a tunable RC network, and wherein the secondary winding has a center tap that is connected to a signal ground via the tunable RC network.

3. The circuit of claim 2, wherein the tunable RC network comprises:

- a switched capacitor array comprising a plurality of capacitors and configured to selectively connect one or more of the capacitors to the center tap responsive to the control signal; and
- a switched resistor array comprising a plurality of resistors and configured to selectively connect one or more of the resistors to the center tap responsive to the control signal.

4. The circuit of claim 2, wherein the primary winding has a primary port connected to a signal ground and a plurality of primary taps surrounding that primary port, wherein the balance tunable balun further comprises a second switched RC network also configured to tune the output imbalance responsive to the control signal, wherein the controller is configured to generate the control signal to selectively connect one of the primary taps to the center tap of the secondary winding, via the second switched RC network, and wherein the controller is configured to control one of the tunable RC network and the second switched RC network for coarsely tuning the output imbalance, and to control the other one of the tunable RC network and the second switched RC network for finely tuning the output imbalance.

5. The circuit of claim 2, wherein the balance tunable balun further comprises a controllable capacitance connected from one port of the secondary winding to the center tap and is configured to output one of the differential signals at that port, and wherein the controller is configured to reduce the output imbalance also by controlling said controllable capacitance.

6. The circuit of claim 5, wherein the controllable capacitance comprises a switched capacitor array comprising a plurality of capacitors and configured to selectively connect one or more of the capacitors from said one port to the center tap responsive to the control signal, and the balance tunable balun further includes a bias resistor statically connected to the center tap irrespective of the control signal.

7. The circuit of claim 2, wherein the balance tunable balun further comprises two controllable capacitances connected from each port of the primary winding to the primary winding's center tap, and wherein the controller is configured to reduce the output imbalance also by controlling said controllable capacitances.

8. The circuit of claim 1, wherein the primary winding has a primary port connected to ground and a plurality of primary taps surrounding that primary port, wherein the secondary winding has a center tap, and wherein the controller is con-

12

figured to generate the control signal to selectively connect one of the primary taps to the center tap of the secondary winding, via the switched RC network.

9. The circuit of claim 1, wherein the secondary winding has a plurality of candidate center taps surrounding the geometric center of the secondary winding, and wherein the controller is configured to generate the control signal to selectively connect one of the candidate center taps, via the switched RC network, to a signal ground.

10. The circuit of claim 1, wherein the control input comprises a binary vector input and the control signal comprises a multi-bit control signal.

11. The circuit of claim 1, wherein the circuit is included in a radio receiver, wherein the single-ended signal comprises a radio frequency signal, and wherein the differential signals comprise radio frequency signals.

12. The circuit of claim 1 wherein the circuit comprises part of a radio receiver, wherein the single-ended signal comprises a radio frequency signal, wherein the secondary winding is configured to generate differential radio frequency signals, wherein the circuit further includes a mixer configured to convert the differential radio frequency signals into differential baseband signals, wherein the detector is configured to detect output imbalance between the differential baseband signals, and wherein the controller is configured to generate the control signal to control the switched RC network to reduce the output imbalance between the differential baseband signals.

13. A method in a circuit for converting a single-ended signal to differential signals that are balanced to have the same amplitudes and opposite phases relative to a reference point of the differential signals, the circuit including a balance tunable balun that comprises a primary winding, a secondary winding, a control input, and a switched resistor-capacitor (RC) network, the method comprising:

- receiving the single-ended signal at the primary winding;
- outputting the differential signals at the secondary winding;
- detecting an output imbalance between the differential signals, the output imbalance comprising an imbalance between the differential signals;
- receiving at the control input a control signal generated based on the detected output imbalance; and
- controlling the switched RC network with the control signal as needed to effectively adjust the reference point of the differential signals to reduce the detected output imbalance.

14. The method of claim 13, wherein controlling the switched RC network comprises tuning a tunable resistor-capacitor (RC) network, and wherein the secondary winding has a center tap that is connected to a signal ground via the tunable RC network.

15. The method of claim 14, wherein the tunable RC network comprises a plurality of capacitors and a plurality of resistors, and wherein tuning the tunable RC network comprises directing the tunable RC network to selectively connect one or more of the capacitors to the center tap, selectively connect one or more of the resistors to the center tap, or both.

16. The method of claim 14, wherein the primary winding has a primary port connected to ground and a plurality of primary taps surrounding that primary port, wherein the balance tunable balun includes a second switched RC network, wherein the method further comprises controlling the second switched RC network to also tune the output imbalance responsive to the control signal by selectively connecting one of the primary taps to the center tap, via the second switched RC network, and wherein controlling one of the tunable RC

13

network and the second switched RC network coarsely tunes the output imbalance, and controlling the other one of the tunable RC network and the second switched RC network finely tunes the output imbalance.

17. The method of claim 14, wherein the balance tunable balun further comprises a controllable capacitance connected from one port of the secondary winding to the center tap wherein outputting the differential signals comprises outputting one of the differential signals at said port, and wherein the method further comprises controlling said controllable capacitance to also tune the output imbalance.

18. The method of claim 17, wherein a bias resistor is statically connected to the center tap, and wherein tuning the tunable RC network comprises controlling a switched capacitor array that is configured selectively connect one or more capacitors to the center tap.

19. The method of claim 14, wherein the balance tunable balun further comprises two controllable capacitances connected from each port of the primary winding to the primary winding's center tap, and wherein the method further comprises controlling said controllable capacitance to also tune the output imbalance.

20. The method of claim 13, wherein the primary winding has a primary port connected to ground and a plurality of primary taps surrounding that primary port, wherein the secondary winding has a center tap, and wherein controlling the switched RC network comprises selectively connecting one of the primary taps to the center tap via the switched RC network.

14

21. The method of claim 13, wherein the secondary winding has a plurality of candidate center taps surrounding the geometric center of the secondary winding, and wherein controlling the switched RC network comprises selectively connecting one of the candidate center taps, via the switched RC network, to a signal ground.

22. The method of claim 13, wherein the control input comprises a binary vector input, and wherein receiving a control signal at the control input comprises receiving a multi-bit control signal at the binary vector input.

23. The method of claim 13, wherein the circuit is included in a radio receiver, wherein the single-ended signal comprises a radio frequency signal, and wherein the differential signals comprise radio frequency signals.

24. The method of claim 13, wherein the circuit comprises part of a radio receiver, wherein receiving the single-ended signal comprises receiving a single-ended radio frequency signal, wherein generating the differential signals comprises generating differential radio frequency signals, wherein the method further includes converting the differential radio frequency signals into differential baseband signals, wherein detecting an output imbalance between the differential signals comprises detecting an output imbalance between the differential baseband signals, and wherein controlling the switched RC network comprises controlling the switched RC network to tune the output imbalance between the differential baseband signals responsive to the control signal.

* * * * *

UNITED STATES PATENT AND TRADEMARK OFFICE
CERTIFICATE OF CORRECTION

PATENT NO. : 8,884,715 B2
APPLICATION NO. : 13/856465
DATED : November 11, 2014
INVENTOR(S) : Mu

Page 1 of 1

It is certified that error appears in the above-identified patent and that said Letters Patent is hereby corrected as shown below:

In the Specification

In Column 1, Line 7, delete “which” and insert -- now Patent No. 8,436,695 which --, therefor.

In Column 2, Line 43, delete “network (SCRN)” and insert -- network (SRCN) --, therefor.

In Column 5, Line 31, delete “(SCRN) 26” and insert -- (SRCN) 26 --, therefor.

In Column 6, Line 18, delete “SCRN 44” and insert -- SRCN 44 --, therefor.

Signed and Sealed this
Fourth Day of August, 2015



Michelle K. Lee
Director of the United States Patent and Trademark Office