



US008852193B2

(12) **United States Patent**  
**Hushka et al.**

(10) **Patent No.:** **US 8,852,193 B2**  
(45) **Date of Patent:** **Oct. 7, 2014**

(54) **SYSTEMS AND METHODS FOR VERTEBRAL DISC REPLACEMENT**

2310/00023 (2013.01); A61F 2002/30354 (2013.01); A61F 2/4425 (2013.01);

(75) Inventors: **Dylan Hushka**, Chandler, AZ (US);  
**Joshua A. Butters**, Chandler, AZ (US);  
**Jeffery D. Arnett**, Gilbert, AZ (US);  
**Neil Duggal**, London (CA)

(Continued)

(58) **Field of Classification Search**  
USPC ..... 606/86 A, 99, 246, 90, 86 B, 86 R  
See application file for complete search history.

(73) Assignee: **Synergy Disc Replacement, Inc.**,  
Kitchener, Ontario (CA)

(56) **References Cited**

(\*) Notice: Subject to any disclaimer, the term of this patent is extended or adjusted under 35 U.S.C. 154(b) by 689 days.

U.S. PATENT DOCUMENTS

(21) Appl. No.: **12/323,068**

1,311,147 A 7/1919 Bernisen  
3,867,728 A 2/1975 Stubstad

(Continued)

(22) Filed: **Nov. 25, 2008**

FOREIGN PATENT DOCUMENTS

(65) **Prior Publication Data**

US 2009/0125033 A1 May 14, 2009

EP 042271 A1 12/1981  
EP 176728 A1 4/1986

(Continued)

**Related U.S. Application Data**

*Primary Examiner* — David Bates

*Assistant Examiner* — Samuel Hanna

(63) Continuation-in-part of application No. 12/258,961, filed on Oct. 27, 2008, which is a continuation-in-part

(74) *Attorney, Agent, or Firm* — Maywood IP Law; Barbara Daniels; David Meibos

(Continued)

(57) **ABSTRACT**

(51) **Int. Cl.**

**A61B 17/70** (2006.01)  
**A61F 2/32** (2006.01)  
**A61F 2/46** (2006.01)  
**A61F 2/44** (2006.01)  
**A61B 17/17** (2006.01)  
**A61B 17/16** (2006.01)  
**A61F 2/30** (2006.01)  
**A61B 17/02** (2006.01)

Methods and instrumentation for implantation of an intervertebral disc prosthesis are provided. A guide tool with sagittal and coronal reference features guides placement of guide pins relative to a sagittal plane and a coronal plane of the vertebrae. A retainer lockable to the guide pins has a ratcheting mechanism providing distraction or compression. A rasp, planer or other tools may be aligned to the retainer and inserted into the intervertebral space to prepare the vertebral endplates. An interoperatively adjustable trial is alignable to the retainer and measures an angularity of the intervertebral space. A prosthesis with keying features may be mounted to a prosthesis inserter with complementary features, held by pivotable arms and compressed between prongs. The inserter may be aligned to the retainer and advanced to implant the prosthesis in the intervertebral space. A prosthesis remover may grip one prosthetic end plate and extract the entire prosthesis.

(52) **U.S. Cl.**

CPC ..... **A61F 2/4684** (2013.01); **A61F 2002/30892** (2013.01); **A61F 2/32** (2013.01); **A61F 2002/30685** (2013.01); **A61F 2002/30426** (2013.01); **A61F 2002/30604** (2013.01); **A61F 2230/0071** (2013.01); **A61F 2002/30841** (2013.01); **A61F 2002/30937** (2013.01); **A61F**

**35 Claims, 44 Drawing Sheets**

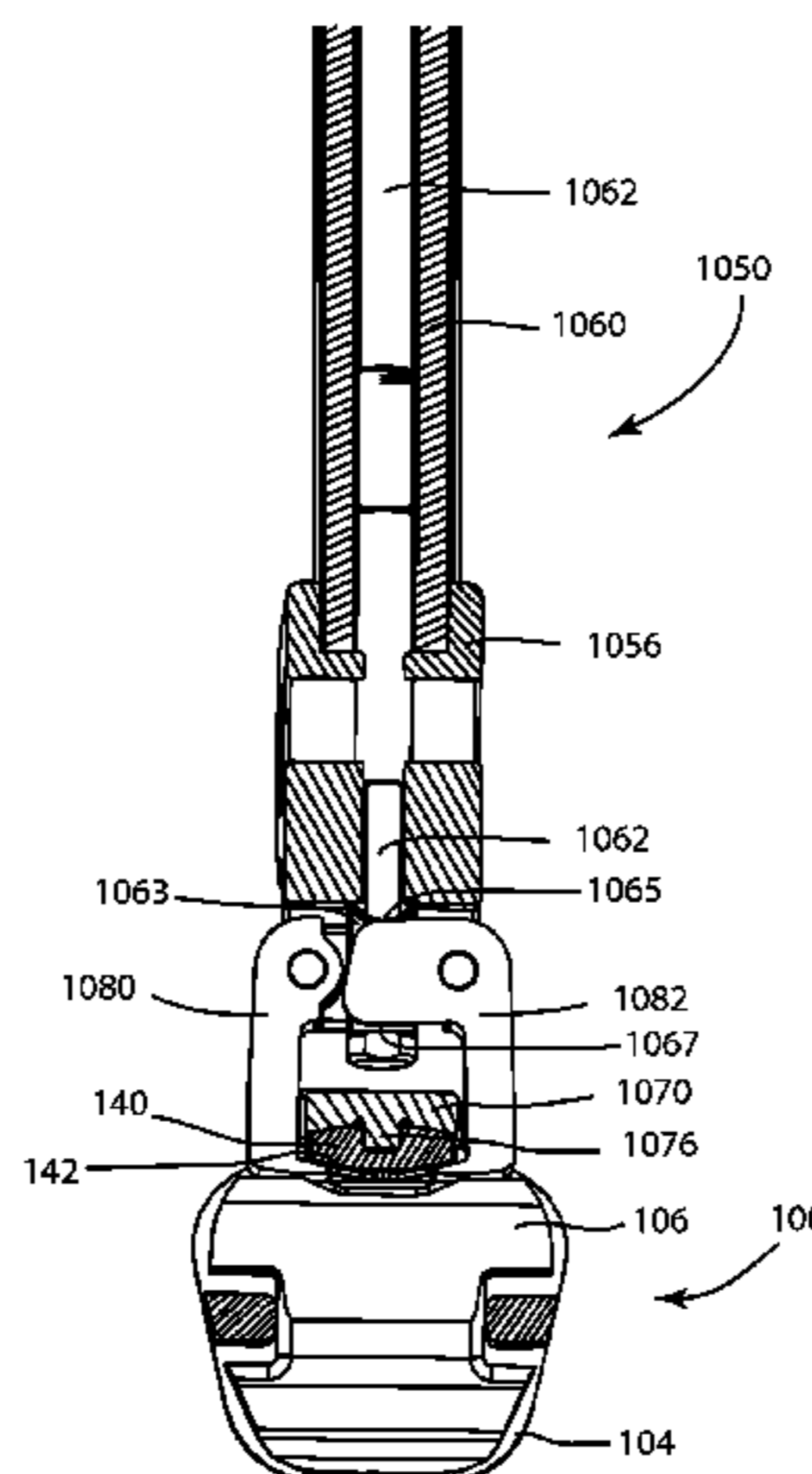
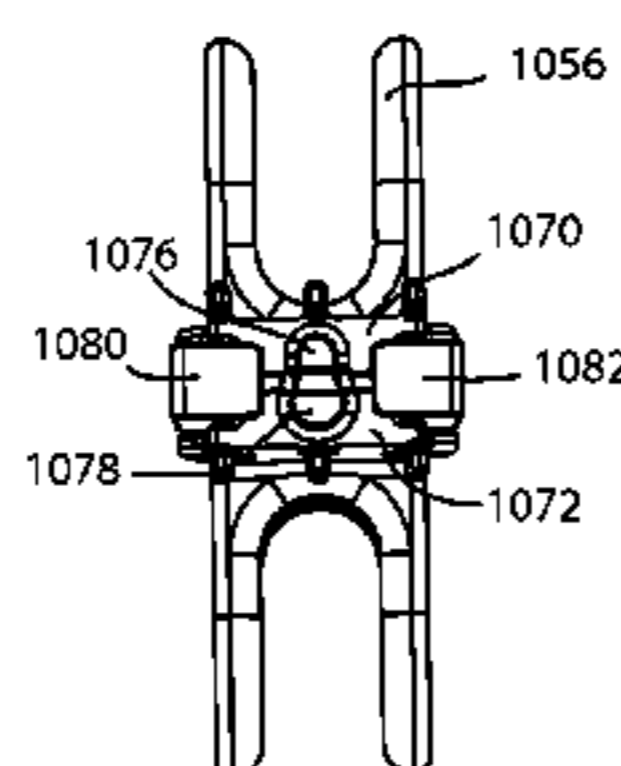

**Related U.S. Application Data**

of application No. 12/041,910, filed on Mar. 4, 2008, and a continuation-in-part of application No. 11/559,215, filed on Nov. 13, 2006, now Pat. No. 7,927,374, and a continuation-in-part of application No. 11/534,014, filed on Sep. 21, 2006, and a continuation-in-part of application No. 10/590,139, filed as application No. PCT/US2005/023134 on Jun. 30, 2005, application No. 12/323,068, filed on Nov. 25, 2008, which is a continuation-in-part of application No. 12/258,977, filed on Oct. 27, 2008.

- (60) Provisional application No. 60/658,161, filed on Mar. 4, 2005, provisional application No. 60/584,240, filed on Jun. 30, 2004, provisional application No. 60/982,627, filed on Oct. 25, 2007, provisional application No. 60/983,500, filed on Oct. 29, 2007, provisional application No. 61/023,019, filed on Jan. 23, 2008, provisional application No. 61/041,086, filed on Mar. 31, 2008, provisional application No. 61/050,531, filed on May 5, 2008, provisional application No. 61/074,498, filed on Jun. 20, 2008.

(52) **U.S. Cl.**

CPC ..... *A61F 2002/30654* (2013.01); *A61F 2002/3069* (2013.01); *A61F 2250/0006* (2013.01); *A61B 17/1757* (2013.01); *A61F 2002/30563* (2013.01); *A61F 2002/30232* (2013.01); *A61F 2002/30369* (2013.01); *A61F 2002/30662* (2013.01); *A61F 2002/4687* (2013.01); *A61B 17/1671* (2013.01); *A61F 2002/3039* (2013.01); *A61F 2002/30242* (2013.01); *A61F 2002/3065* (2013.01); *A61F 2002/30904* (2013.01); *A61F 2/4611* (2013.01); *A61F 2002/30663* (2013.01); *A61F 2310/00407* (2013.01); *A61F 2002/30616* (2013.01); *A61F 2230/0065* (2013.01); *A61F 2310/00796* (2013.01); *A61F 2002/30364* (2013.01); *A61B 2017/0256* (2013.01); *A61F 2220/0025* (2013.01); *A61F 2002/30578* (2013.01); *A61F 2310/00017* (2013.01); *A61B 17/1604* (2013.01); *A61F 2002/302* (2013.01); *A61F 2002/30397* (2013.01); *A61F 2002/30843* (2013.01); *A61F 2002/443* (2013.01); *A61F 2002/30383* (2013.01); *A61F 2/4657* (2013.01); *A61F 2002/30884* (2013.01); *A61F 2002/30538* (2013.01); *A61F 2230/0069* (2013.01); *A61F 2310/00179* (2013.01); *A61F 2002/30652* (2013.01); *A61F 2002/30934* (2013.01); *A61F 2310/00029* (2013.01); *A61F 2002/30655* (2013.01); *A61F 2002/305* (2013.01); *A61F 2002/4658* (2013.01); *A61F 2220/0033* (2013.01)  
 USPC ..... **606/86 A**; 606/99; 606/279; 606/246

5,002,576 A	3/1991	Fuhrmann
5,071,437 A	12/1991	Steffee
5,123,926 A	6/1992	Pisharodi
5,258,031 A	11/1993	Salib
5,306,308 A	4/1994	Gross
5,314,477 A	5/1994	Marnay
5,320,644 A	6/1994	Baumgartner
5,350,644 A	9/1994	Graetzel
5,370,697 A	12/1994	Baumgartner
5,401,269 A	3/1995	Buttner-Janzen
5,458,642 A	10/1995	Beer
5,507,816 A	4/1996	Bullivant
5,534,029 A	7/1996	Shima
5,534,030 A	7/1996	Navarro
5,556,431 A	9/1996	Buttner-Janzen
5,645,596 A	7/1997	Kim
5,674,294 A	10/1997	Bainville
5,676,701 A	10/1997	Yuan
5,676,702 A	10/1997	Ratron
5,683,464 A *	11/1997	Wagner et al. .... 623/17.16
5,683,465 A	11/1997	Shinn
5,702,450 A	12/1997	Bisserie
5,755,796 A	5/1998	Ibo
5,824,094 A	10/1998	Serhan
5,827,328 A	10/1998	Buttermann
5,865,846 A	2/1999	Bryan
5,888,224 A *	3/1999	Beckers et al. .... 623/17.16
5,888,226 A	3/1999	Rogozinski
5,893,889 A	4/1999	Harrington
5,895,428 A	4/1999	Berry
5,898,428 A	4/1999	Zimlich
5,899,941 A	5/1999	Nishijima
5,919,235 A	7/1999	Husson
5,928,284 A	7/1999	Mehdizadeh
5,989,291 A	11/1999	Ralph
6,001,130 A	12/1999	Bryan
6,019,792 A	2/2000	Cauthen
6,039,763 A	3/2000	Shelokov
6,051,751 A	4/2000	Sioshansi
6,063,121 A	5/2000	Xavier
6,066,174 A	5/2000	Farris
6,113,637 A	9/2000	Gill
6,136,031 A	10/2000	Middleton
6,146,421 A	11/2000	Gordon
6,146,422 A	11/2000	Lawson
6,179,874 B1	1/2001	Cauthen
6,368,350 B1	4/2002	Erickson
6,375,682 B1	4/2002	Fleischmann
6,402,785 B1	6/2002	Zdeblick
6,416,551 B1	7/2002	Keller
6,468,310 B1	10/2002	Ralph
6,478,800 B1	11/2002	Fraser
6,517,580 B1	2/2003	Ramadan
6,520,996 B1	2/2003	Manasas
6,527,804 B1	3/2003	Gauchet
6,562,045 B2	5/2003	Gil
6,579,320 B1	6/2003	Gauchet
6,579,321 B1	6/2003	Gordon
6,592,624 B1	7/2003	Fraser
6,599,320 B1	7/2003	Kuslich
6,610,093 B1	8/2003	Pisharodi
6,626,943 B2	9/2003	Eberlein
6,652,533 B2	11/2003	O'Neil
6,669,730 B2	12/2003	Ralph
6,682,562 B2	1/2004	Viard
6,706,068 B2	3/2004	Ferree
6,709,439 B2	3/2004	Rogers
6,726,720 B2	4/2004	Ross
6,740,118 B2	5/2004	Eisermann
6,749,635 B1	6/2004	Bryan
6,761,723 B2	7/2004	Buttermann
6,770,094 B2	8/2004	Fehling
6,770,095 B2	8/2004	Grinberg
6,793,678 B2	9/2004	Hawkins
6,881,228 B2	4/2005	Zdeblick
6,899,735 B2	5/2005	Coates
6,908,484 B2	6/2005	Zubok
6,936,071 B1	8/2005	Marnay
6,949,105 B2	9/2005	Bryan

(56)

**References Cited**

U.S. PATENT DOCUMENTS

3,875,595 A	4/1975	Froning
4,309,777 A	1/1982	Patil
4,714,469 A	12/1987	Kenna
4,863,476 A	9/1989	Shepperd
4,863,477 A	9/1989	Monson
4,874,389 A	10/1989	Downey
4,911,718 A	3/1990	Lee
4,946,378 A	8/1990	Hirayama
4,997,432 A	3/1991	Keller

# US 8,852,193 B2

6,960,232	B2	11/2005	Lyons	2004/0158328	A1	8/2004	Eisermann
6,964,686	B2	11/2005	Gordon	2004/0243240	A1	12/2004	Beurain
6,966,929	B2	11/2005	Mitchell	2005/0015149	A1*	1/2005	Michelson ..... 623/17.11
6,976,988	B2	12/2005	Ralph	2005/0015152	A1	1/2005	Sweeney
6,986,789	B2	1/2006	Schultz	2005/0033305	A1*	2/2005	Schultz ..... 606/99
6,989,032	B2	1/2006	Errico	2005/0101991	A1*	5/2005	Ahlberg et al. .... 606/205
6,994,727	B2	2/2006	Khandkar	2005/0113926	A1	5/2005	Zucherman
7,001,432	B2	2/2006	Keller	2005/0149053	A1*	7/2005	Varieur et al. .... 606/104
7,001,433	B2	2/2006	Songer	2005/0216086	A1	9/2005	Marik
7,025,787	B2	4/2006	Bryan	2005/0228500	A1*	10/2005	Kim et al. .... 623/17.13
7,048,764	B2	5/2006	Ferree	2005/0273173	A1*	12/2005	Gordon et al. .... 623/17.16
7,048,766	B2	5/2006	Ferree	2005/0283248	A1*	12/2005	Gordon et al. .... 623/17.16
7,056,344	B2	6/2006	Huppert	2006/0004377	A1*	1/2006	Keller ..... 606/99
7,060,097	B2	6/2006	Fraser	2006/0030860	A1*	2/2006	Peterman ..... 606/99
7,060,099	B2	6/2006	Carli	2006/0030862	A1	2/2006	De Villiers
7,066,961	B2	6/2006	Michelson	2006/0052872	A1	3/2006	Studer
7,101,400	B2	9/2006	Thramann	2006/0116768	A1	6/2006	Krueger
7,105,024	B2	9/2006	Richelsoph	2006/0136061	A1	6/2006	Navarro
7,118,580	B1	10/2006	Beyersdorff	2006/0155377	A1	7/2006	Beurain et al.
7,147,665	B1	12/2006	Bryan	2007/0100453	A1*	5/2007	Parsons et al. .... 623/17.14
7,153,325	B2	12/2006	Kim	2007/0198093	A1	8/2007	Brodke
7,156,848	B2	1/2007	Ferree	2007/0225812	A1	9/2007	Gill
7,156,876	B2	1/2007	Moumene	2008/0033563	A1	2/2008	Khandkar et al.
7,166,131	B2	1/2007	Studer	2008/0177275	A1*	7/2008	Wing et al. .... 606/99
7,179,294	B2	2/2007	Eisermann	2008/0306488	A1*	12/2008	Altarac et al. .... 606/99
7,201,776	B2	4/2007	Ferree	2009/0182343	A1	7/2009	Trudeau
7,204,852	B2	4/2007	Marnay	2009/0204219	A1	8/2009	Beurain et al.
7,217,291	B2	5/2007	Zucherman	2009/0216330	A1	8/2009	Geisert
7,226,452	B2	6/2007	Zubok				
7,235,101	B2	6/2007	Berry				
7,244,275	B2	7/2007	Michelson				
7,250,060	B2	7/2007	Trieu				
7,255,714	B2	8/2007	Malek				
7,267,691	B2	9/2007	Keller				
7,276,082	B2	10/2007	Zdeblick				
7,291,171	B2	11/2007	Ferree				
7,325,260	B1	2/2008	Hoyt				
7,364,589	B2	4/2008	Eisermann				
7,462,182	B2	12/2008	Lim				
7,569,067	B2*	8/2009	Keller ..... 606/206				
7,618,423	B1*	11/2009	Valentine et al. .... 606/99				
2002/0035400	A1	3/2002	Bryan				
2003/0083747	A1*	5/2003	Winterbottom et al. ... 623/17.11				
2003/0187506	A1*	10/2003	Ross et al. .... 623/17.13				
2004/0148027	A1*	7/2004	Errico et al. .... 623/17.11				
2004/0153157	A1	8/2004	Keller				

## FOREIGN PATENT DOCUMENTS

EP	282161	A1	9/1988
EP	298233	A1	1/1989
FR	2730159		8/1996
FR	2805985		9/2001
WO	WO9526697	A1	10/1995
WO	WO2004041131		5/2004
WO	WO2004064692	A2	8/2004
WO	WO2004089259	A1	10/2004
WO	WO2005039455	A1	5/2005
WO	WO2005046534	A1	5/2005
WO	WO2005053580	A1	6/2005
WO	WO2007041375		4/2007
WO	WO2007063398	A2	6/2007

\* cited by examiner

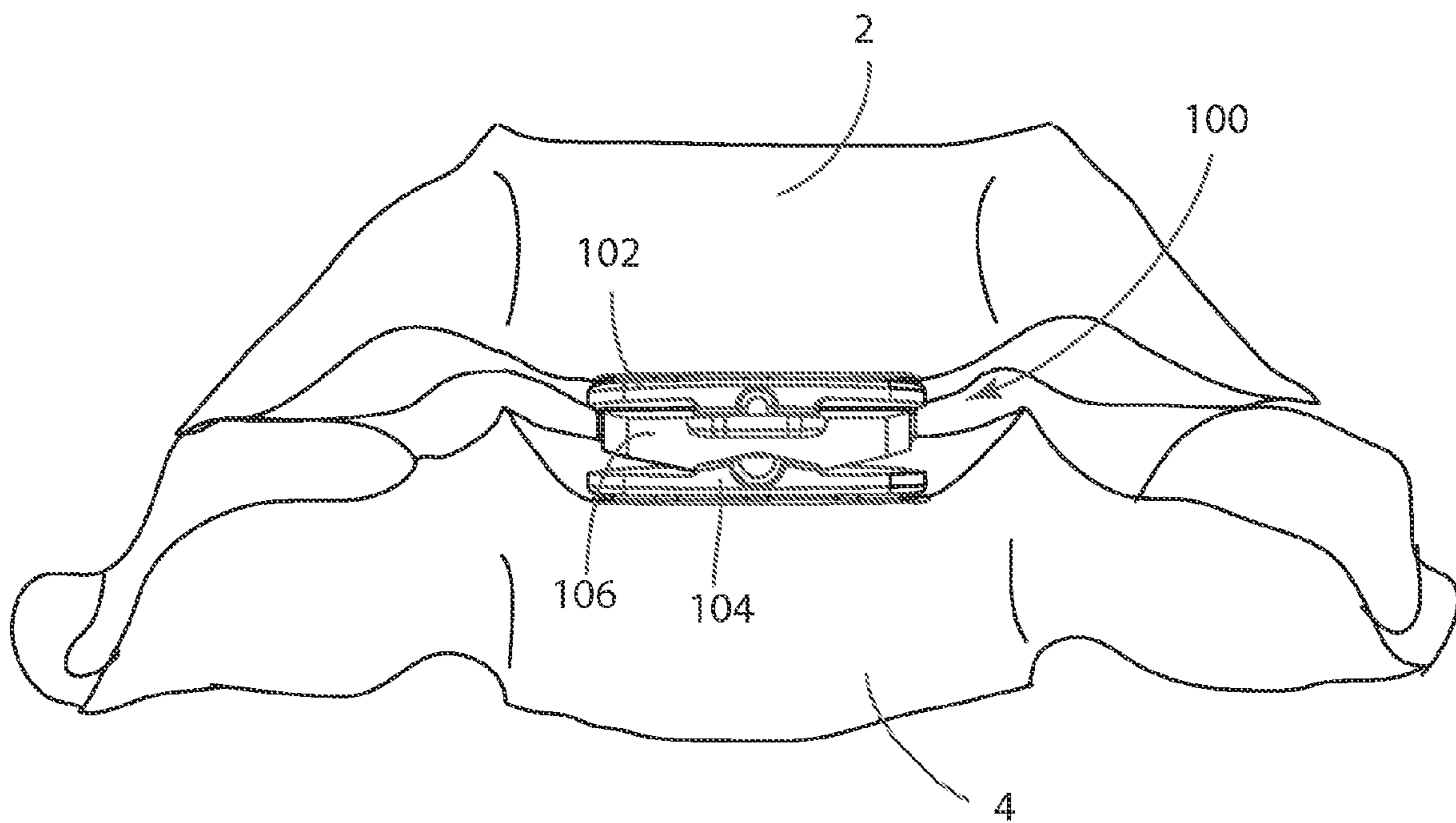

Fig. 1

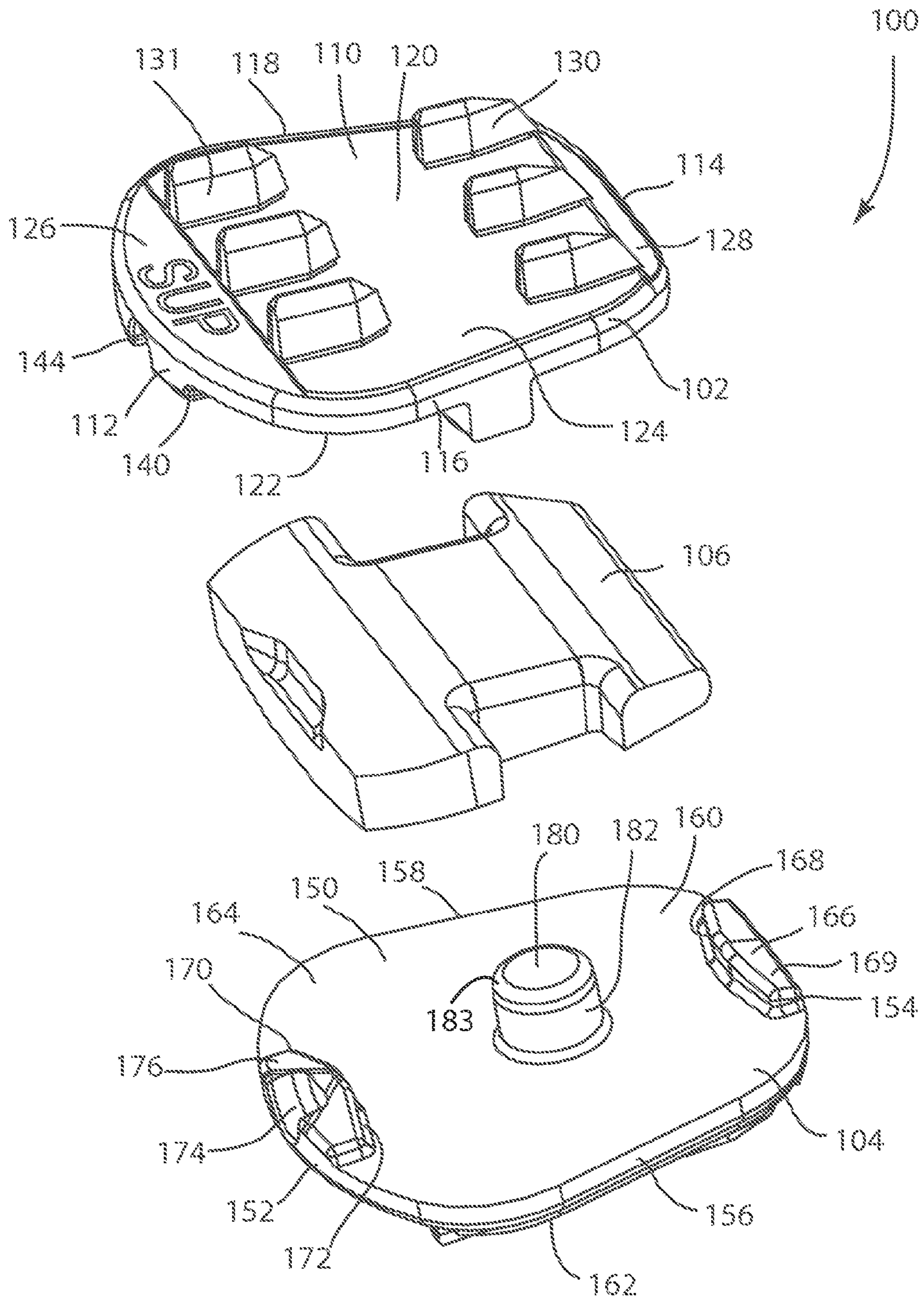

Fig. 2

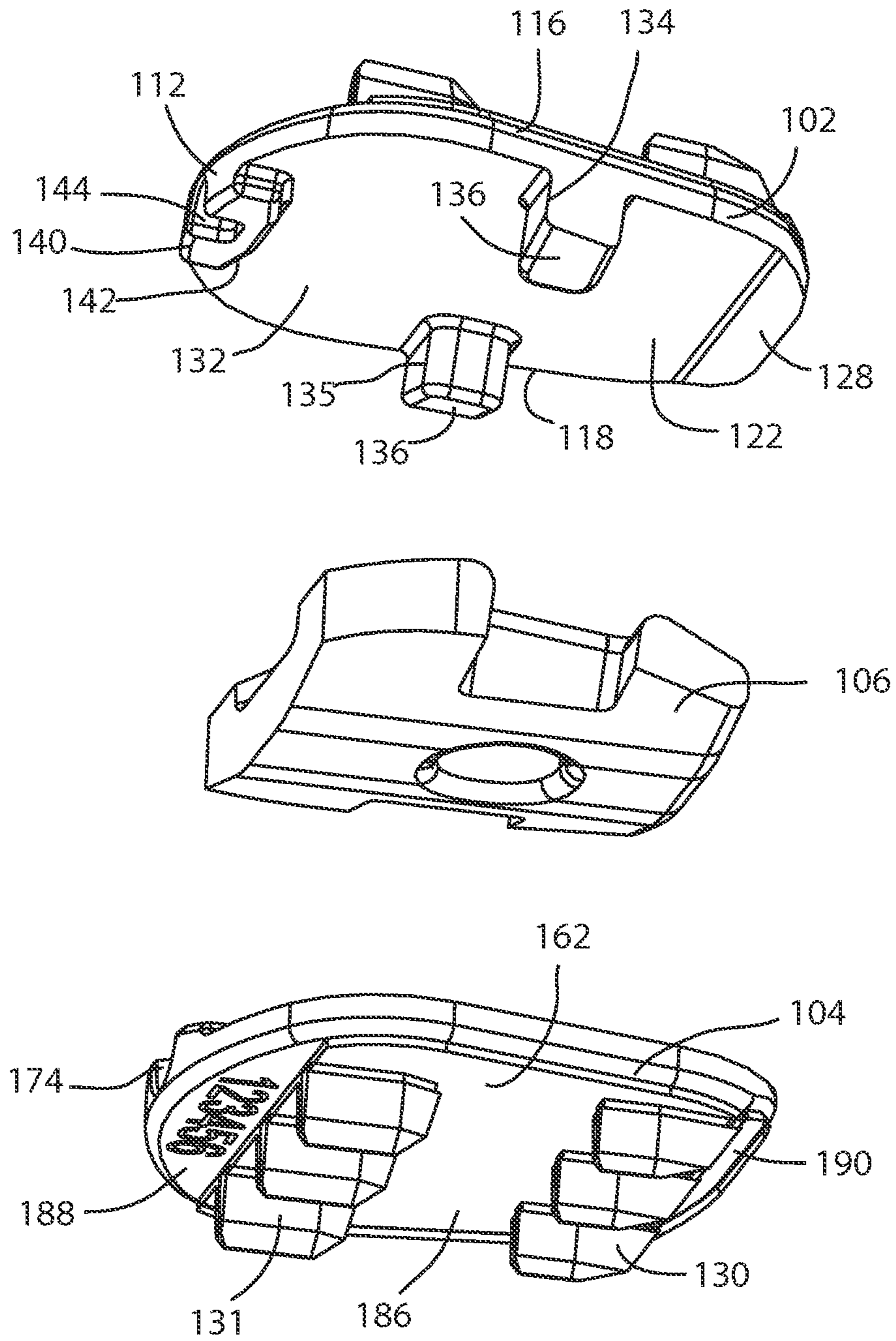

Fig. 3

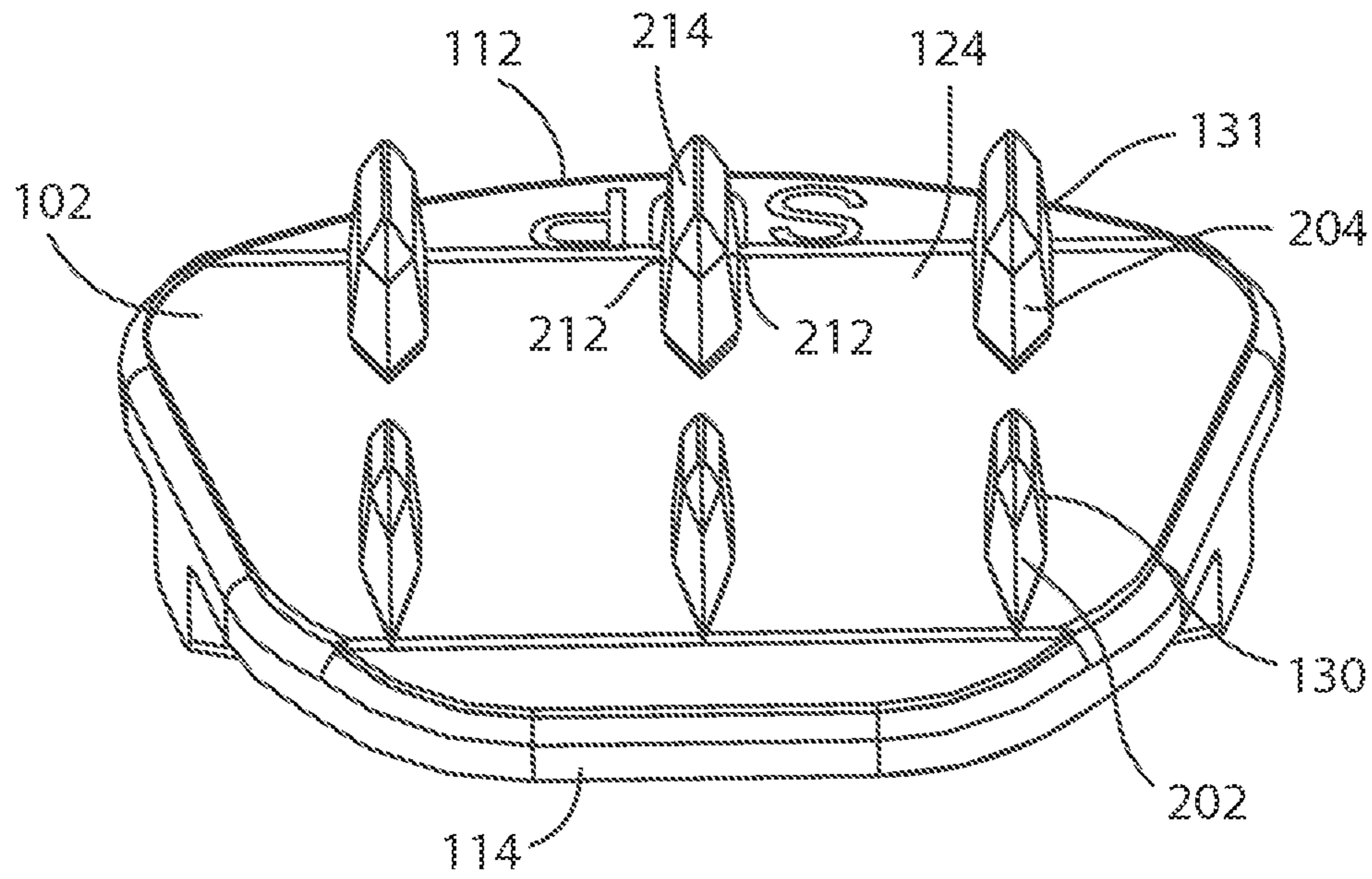

Fig. 4A

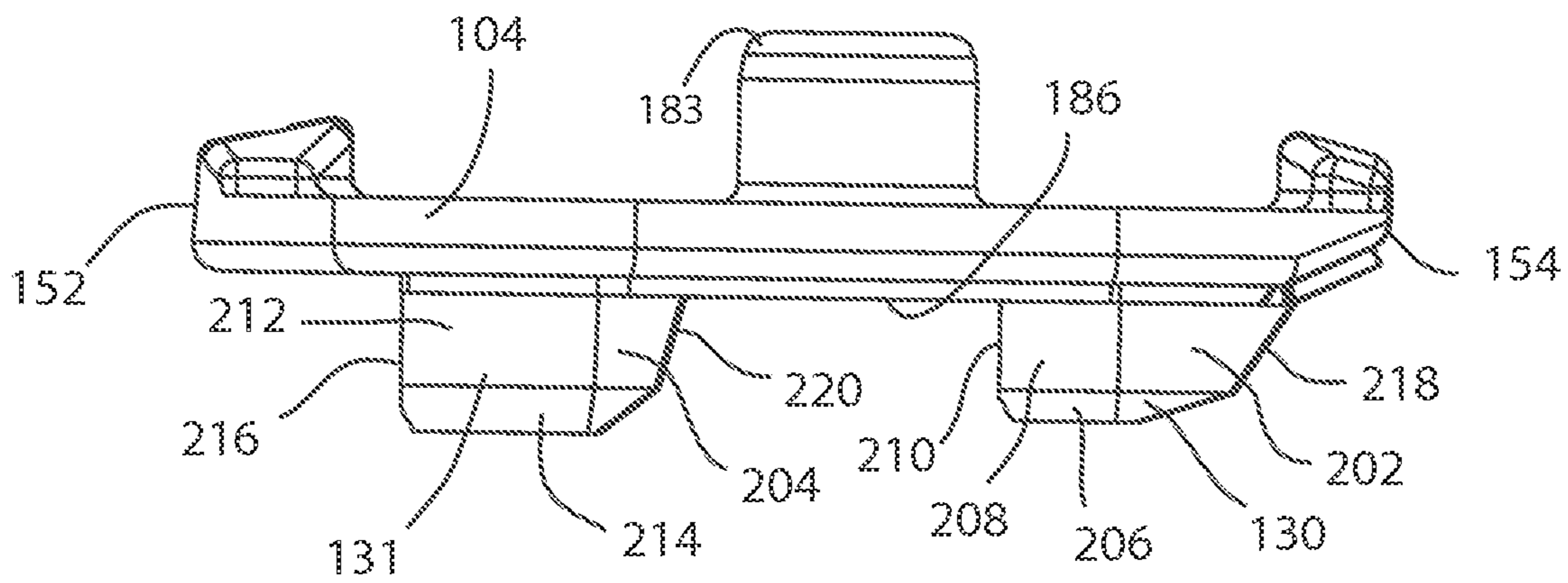
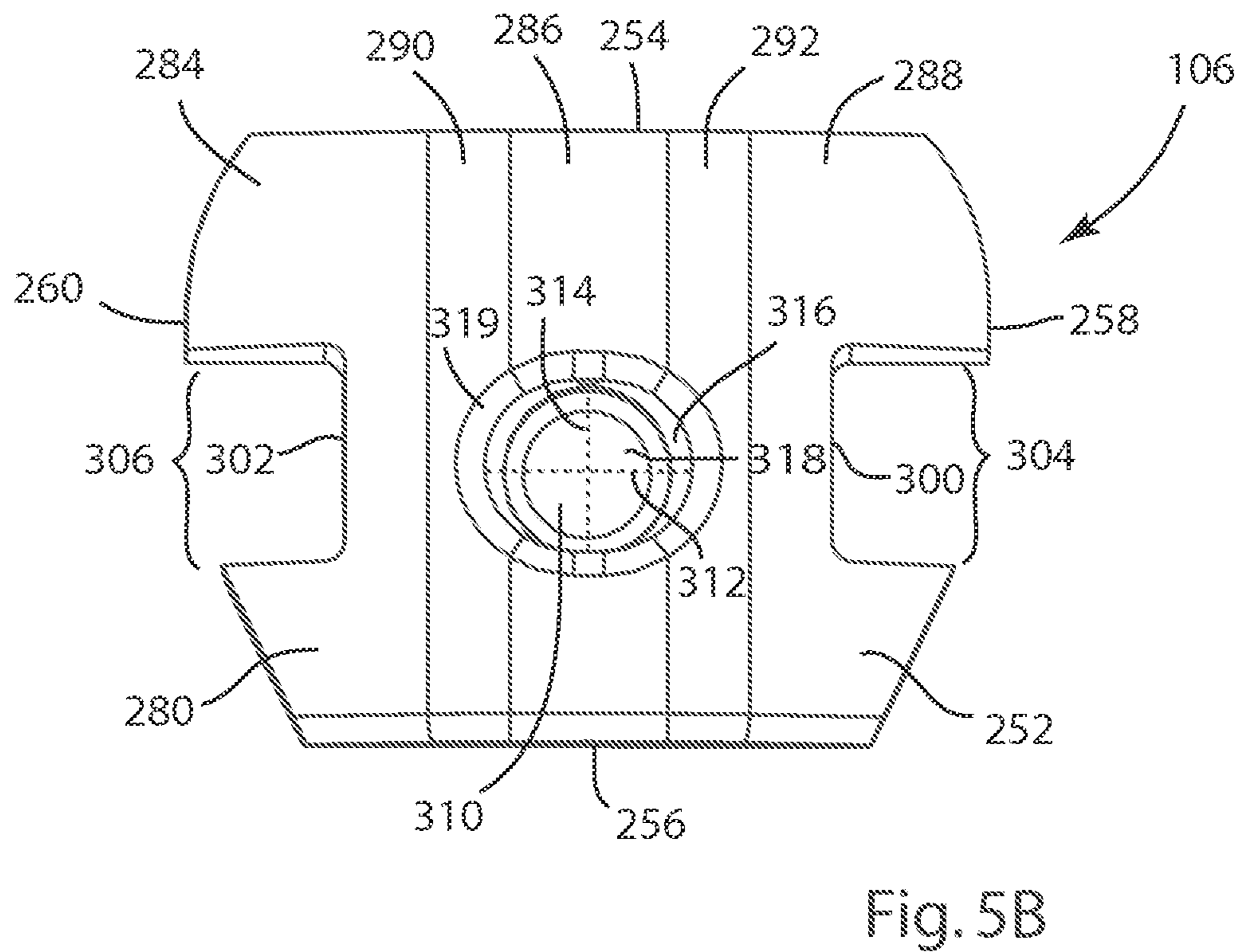
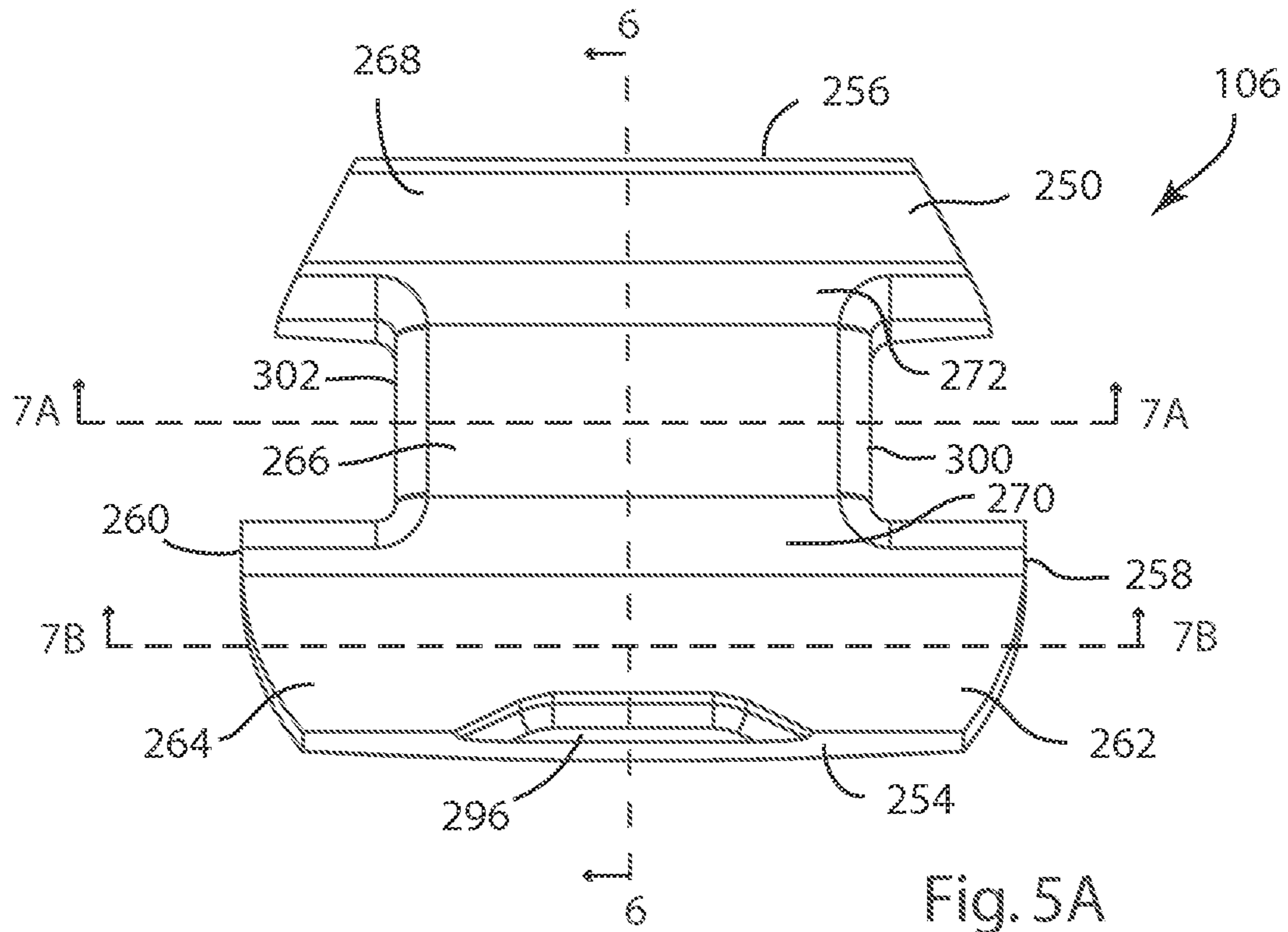

Fig. 4B





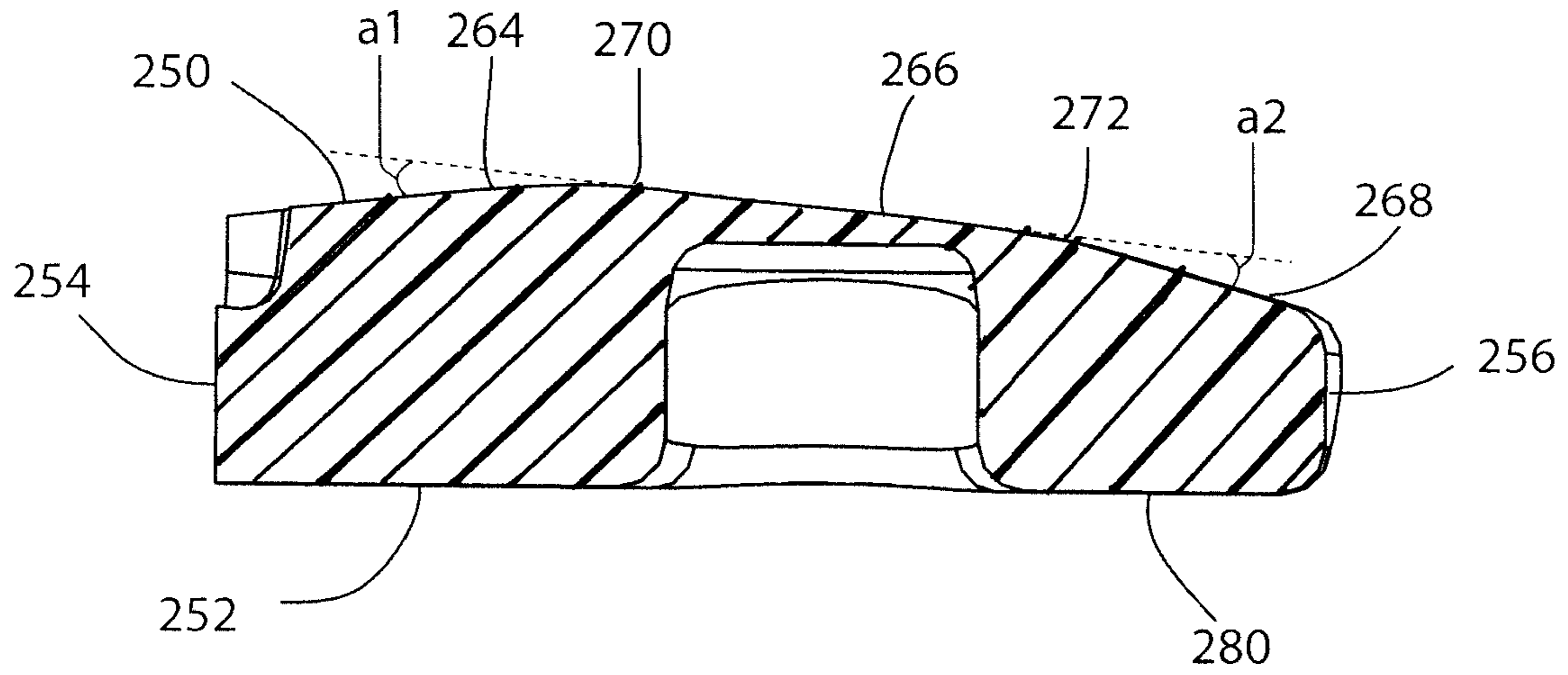

Fig. 6

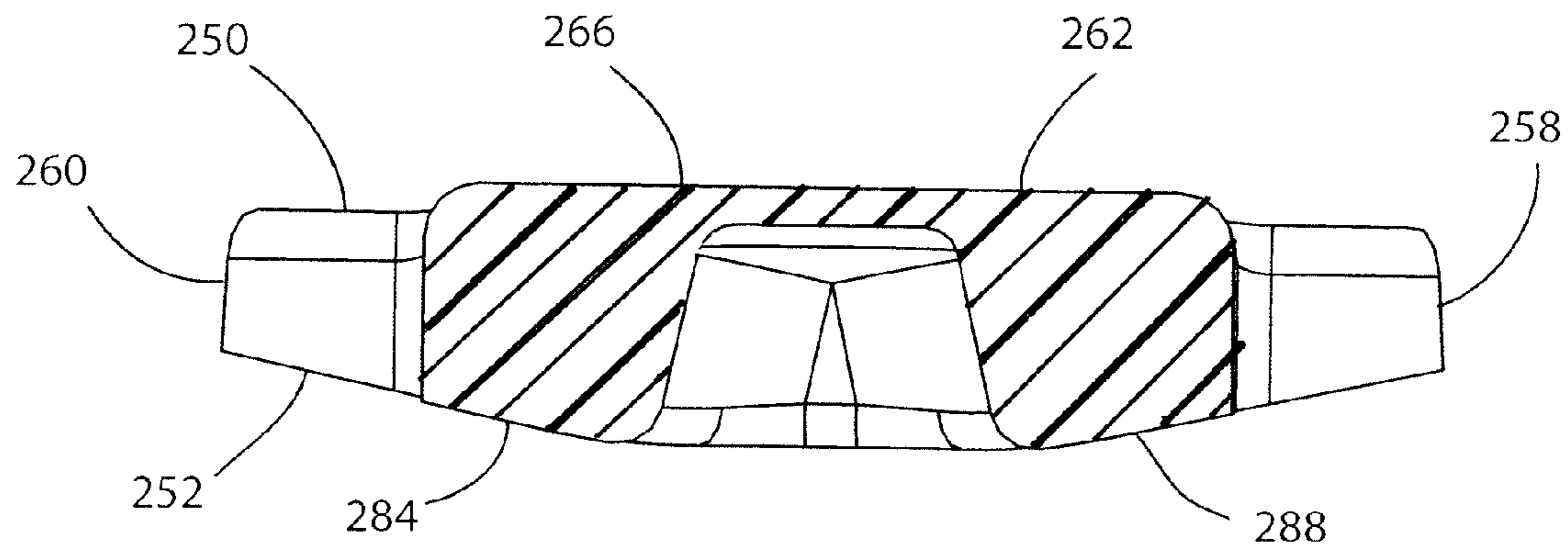

Fig. 7A

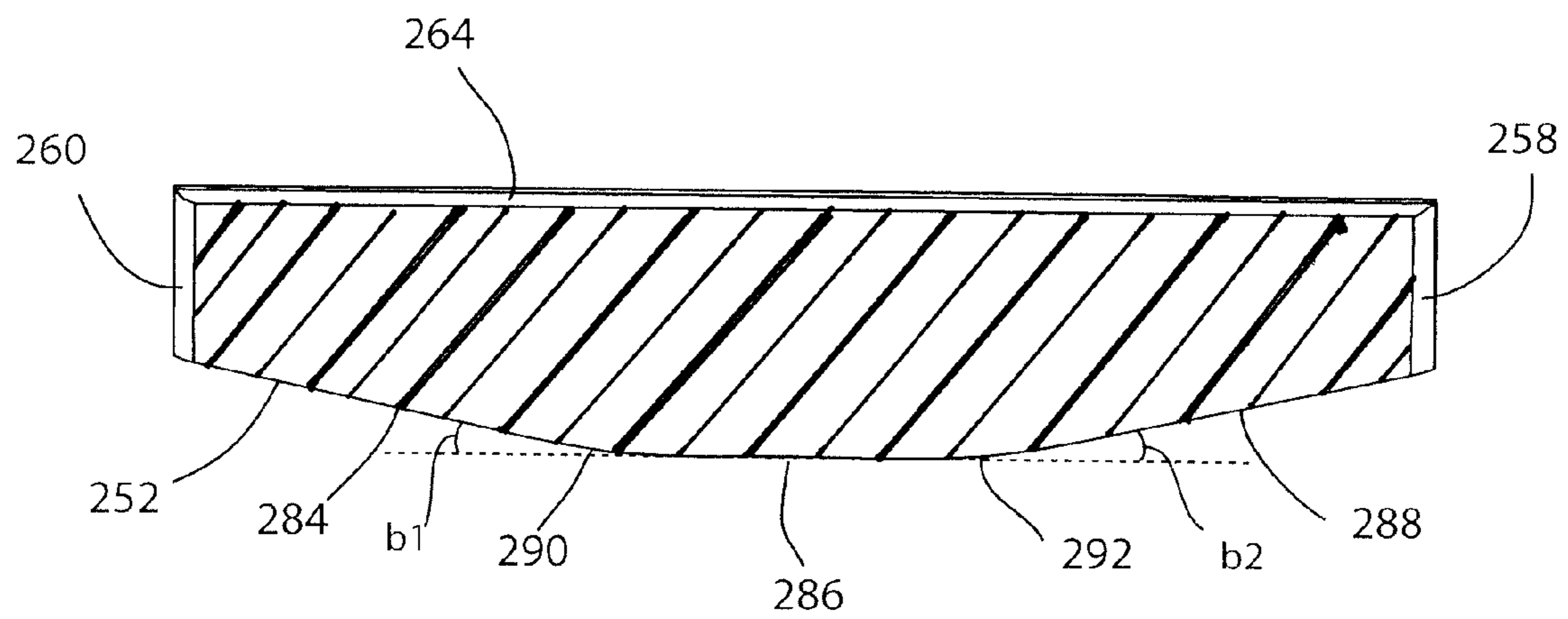

Fig. 7B

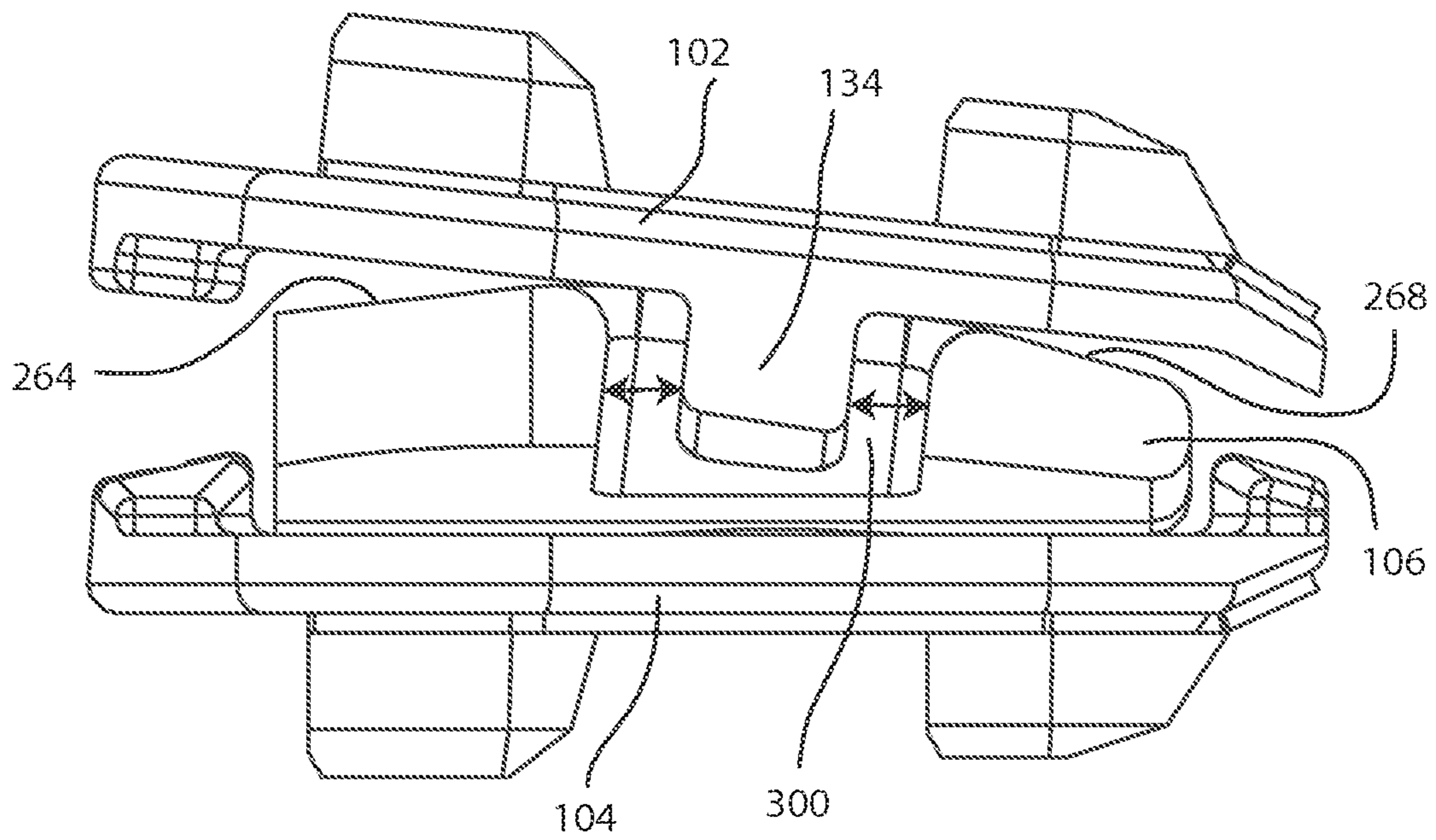

Fig. 8

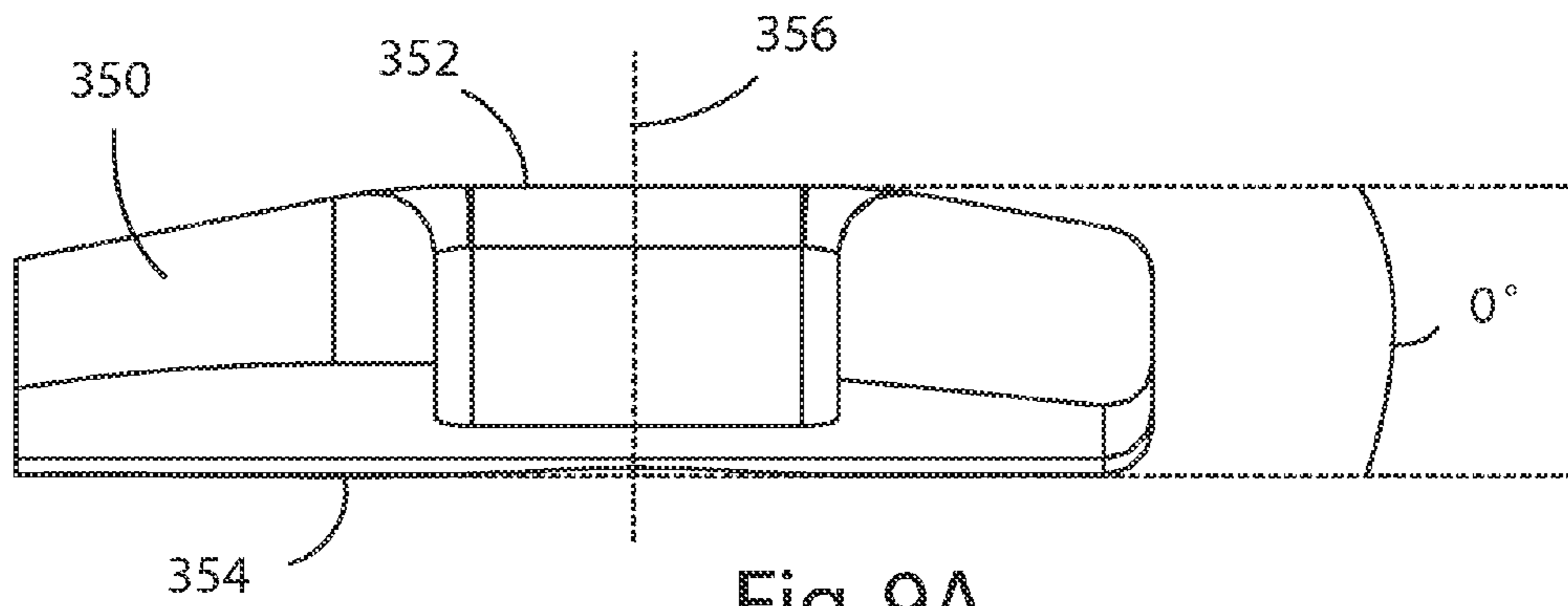

Fig. 9A

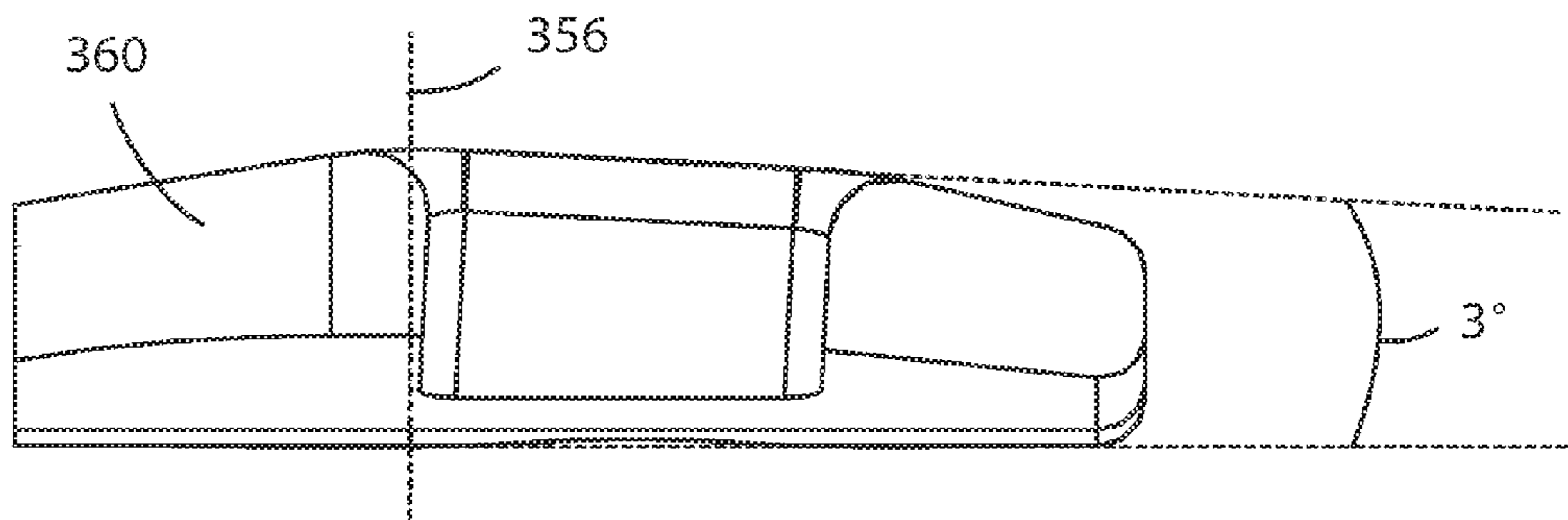

Fig. 9B

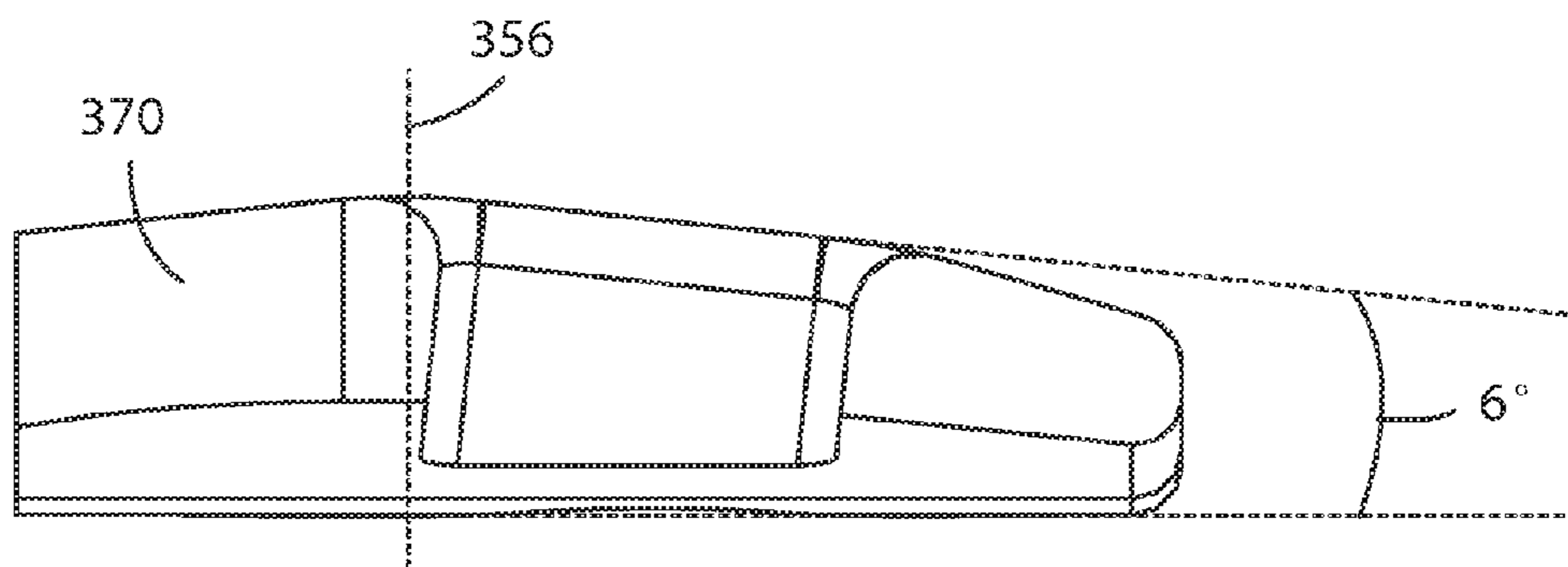

Fig. 9C

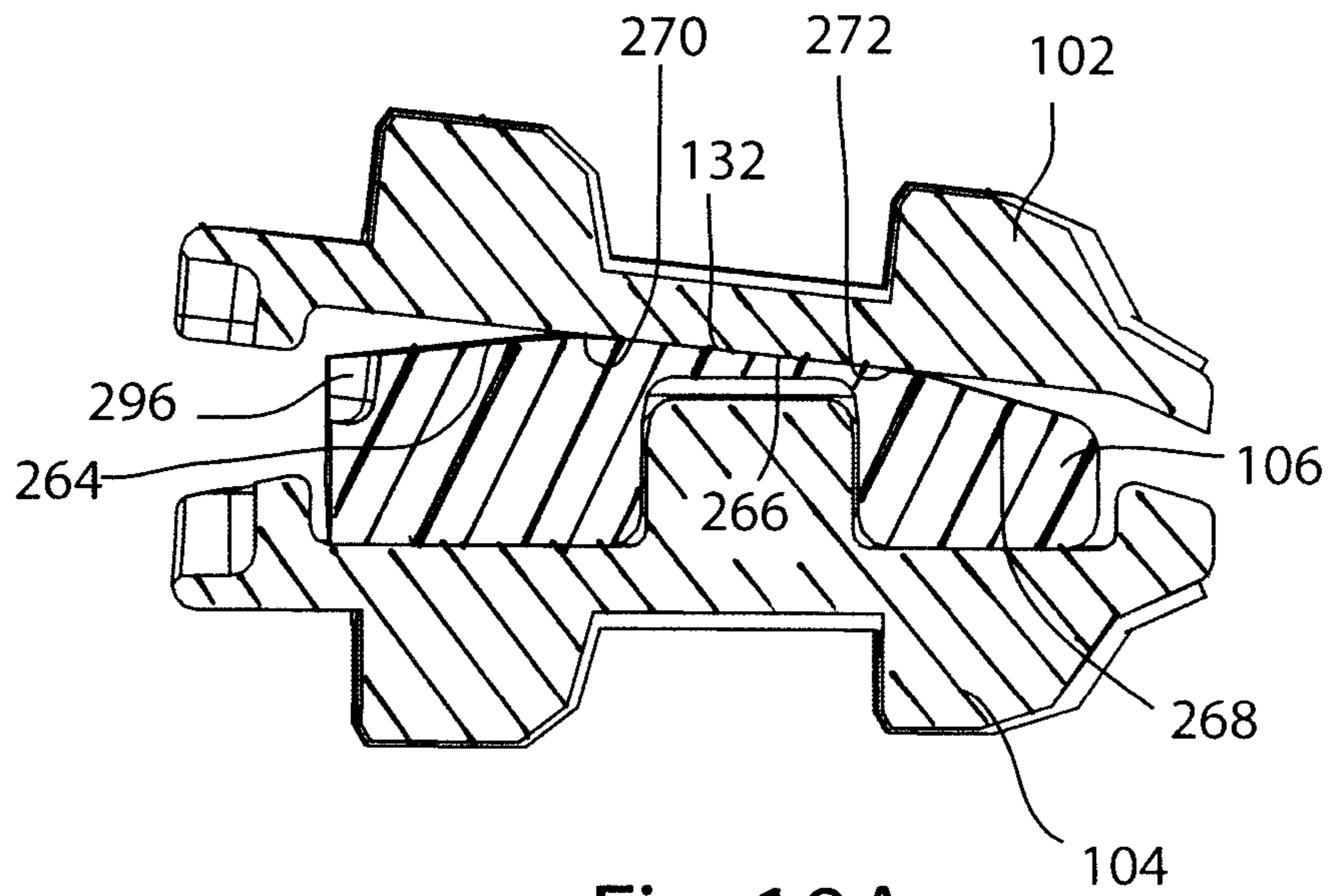

Fig. 10A

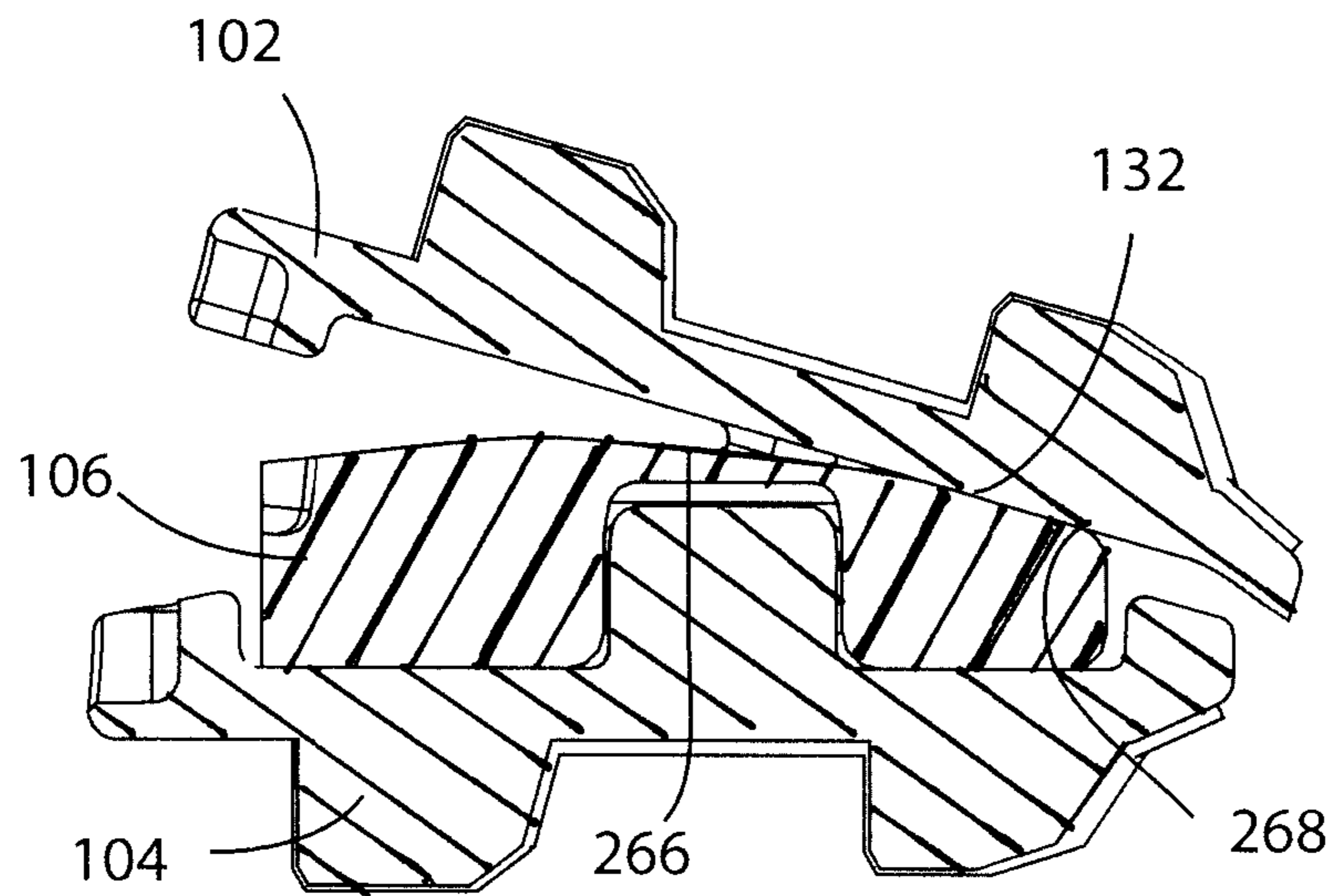

Fig. 10B

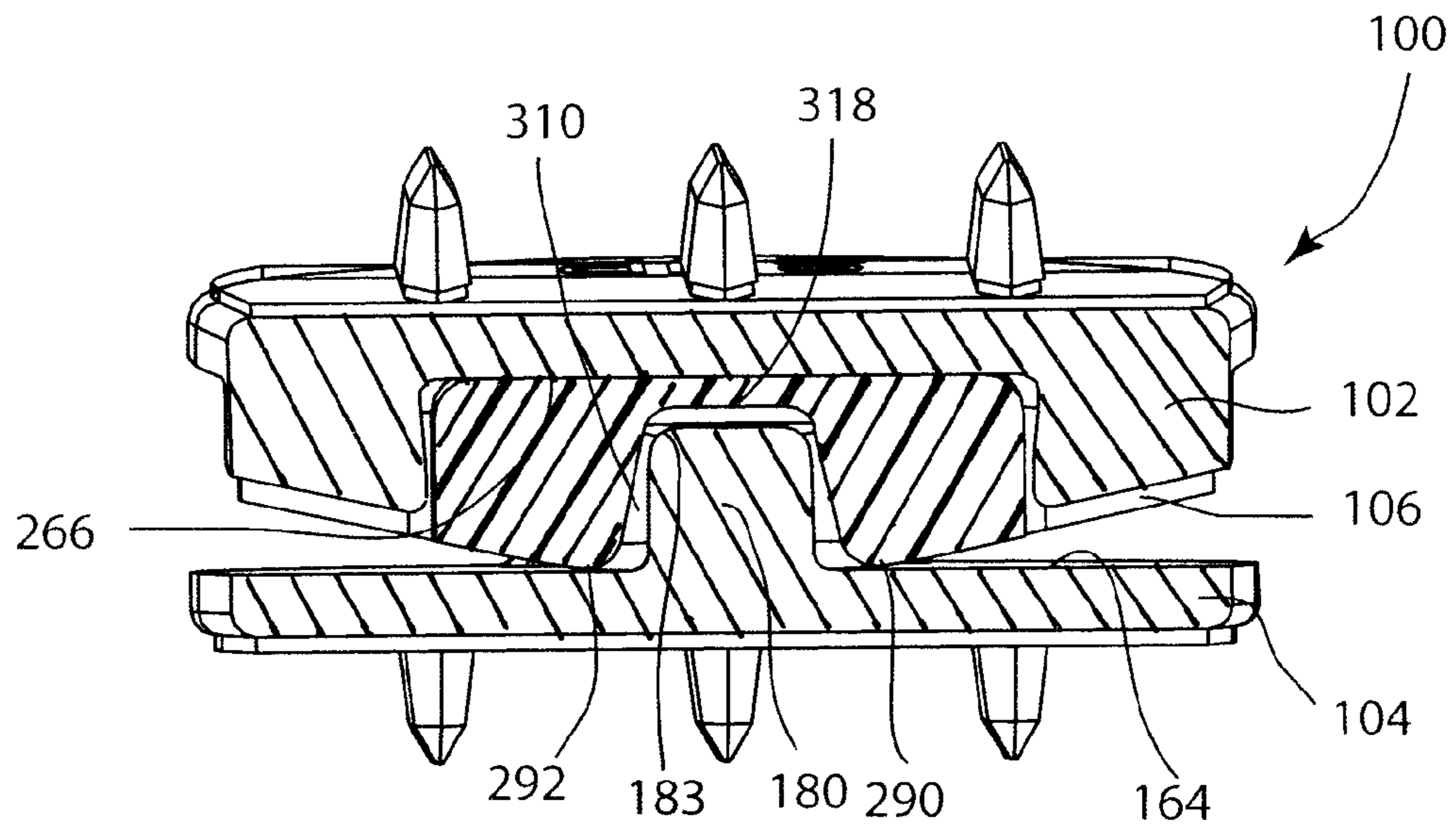

Fig. 11A

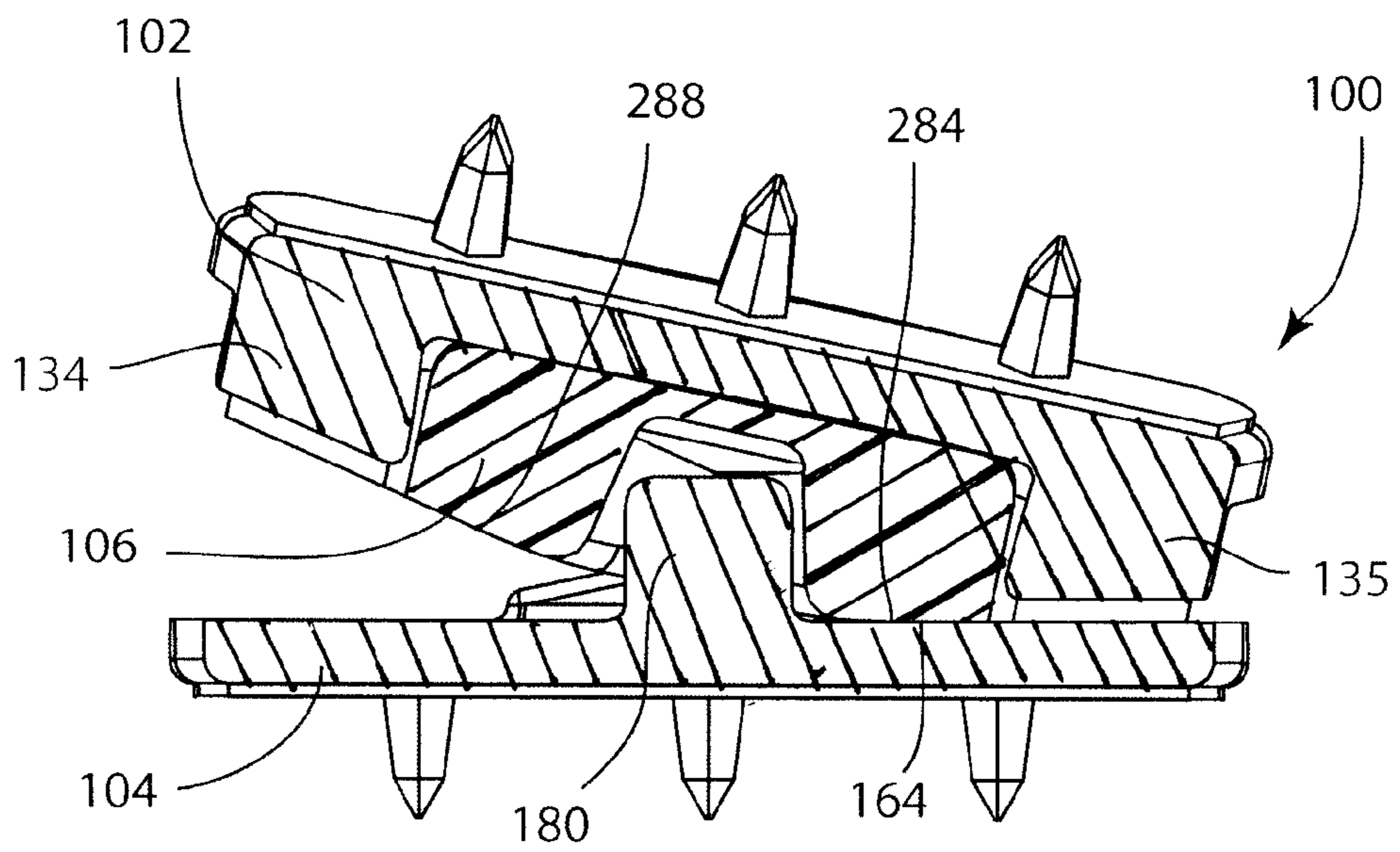

Fig. 11B

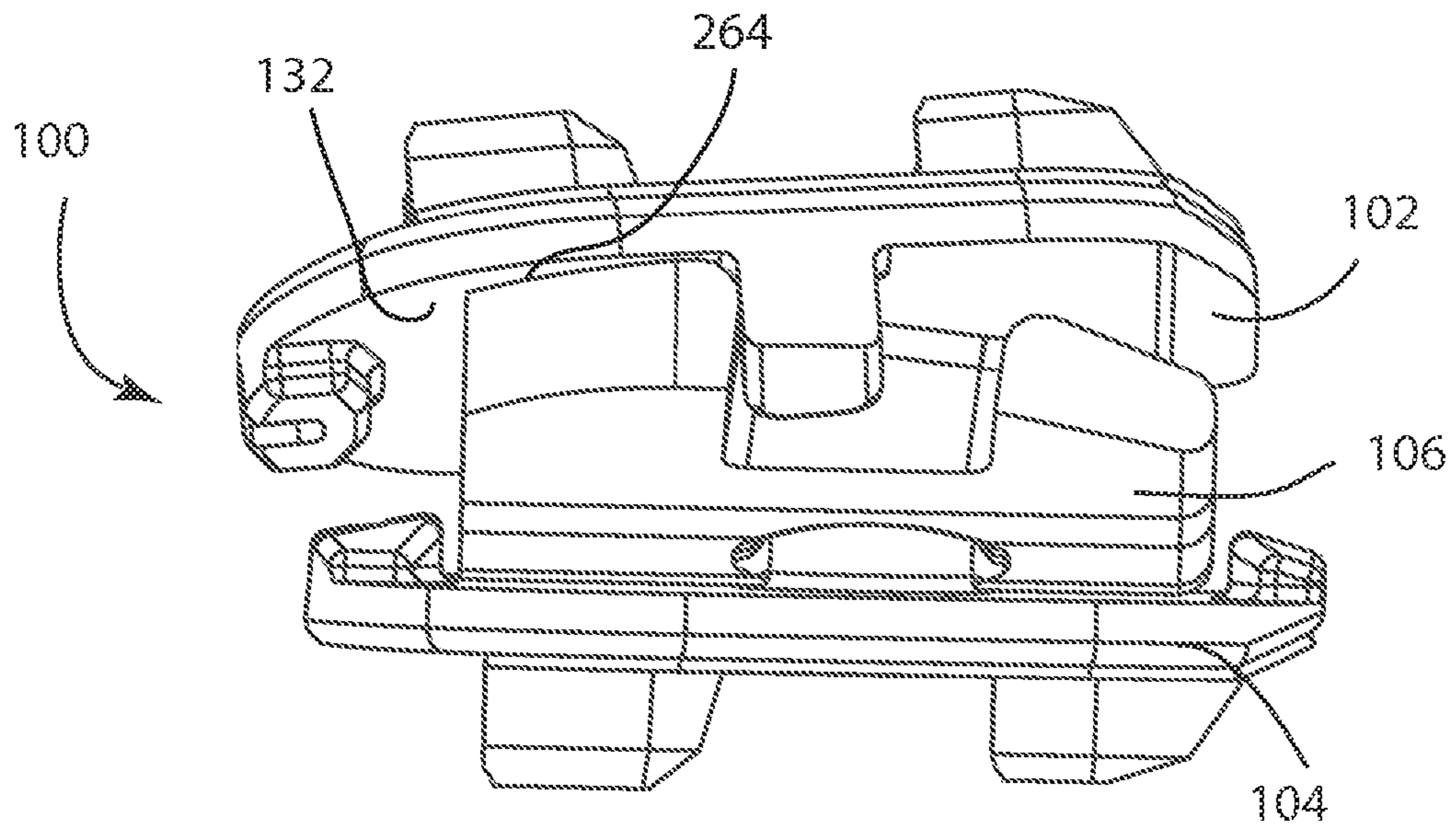

Fig. 12A

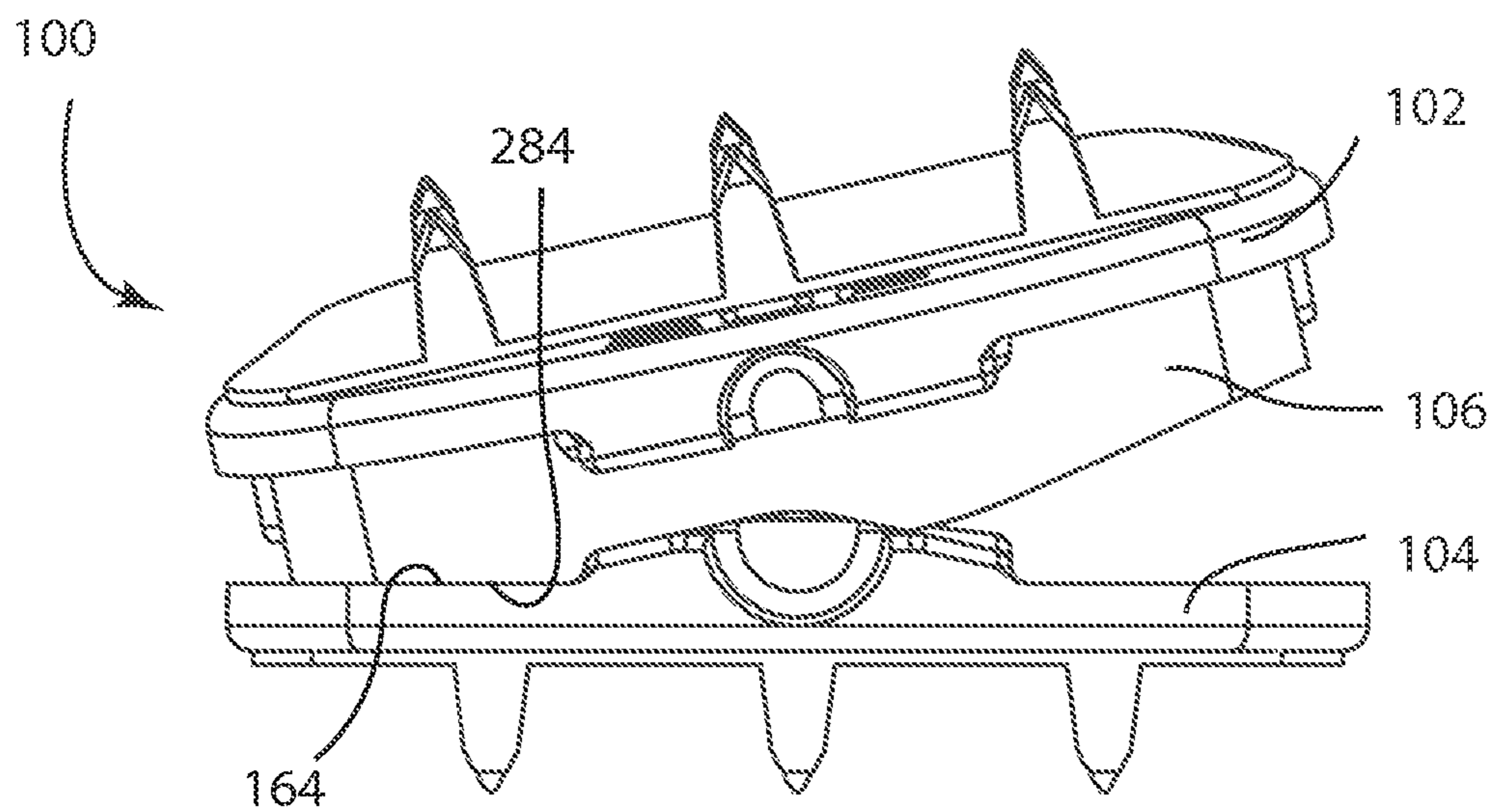

Fig. 12B

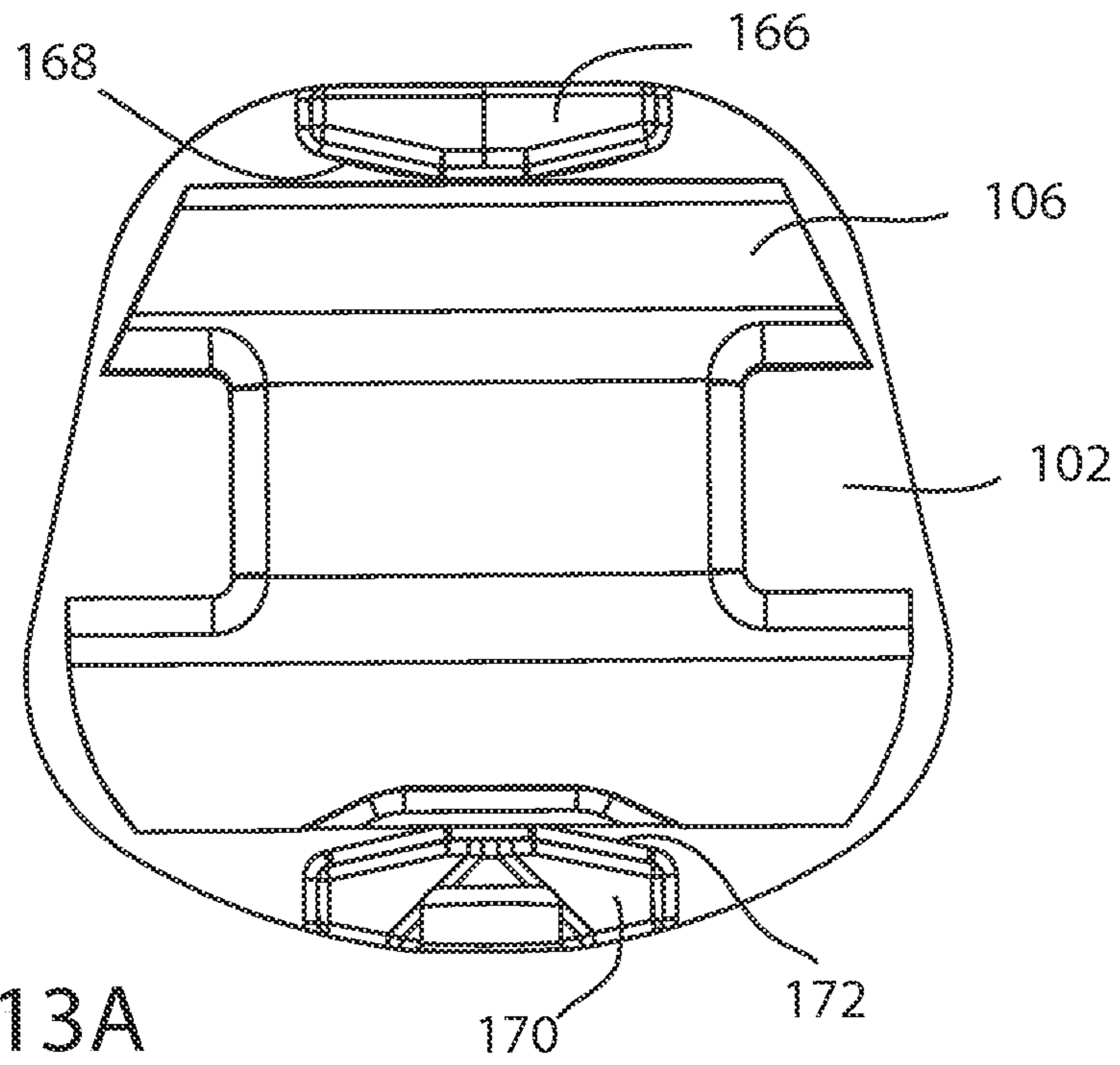

Fig. 13A

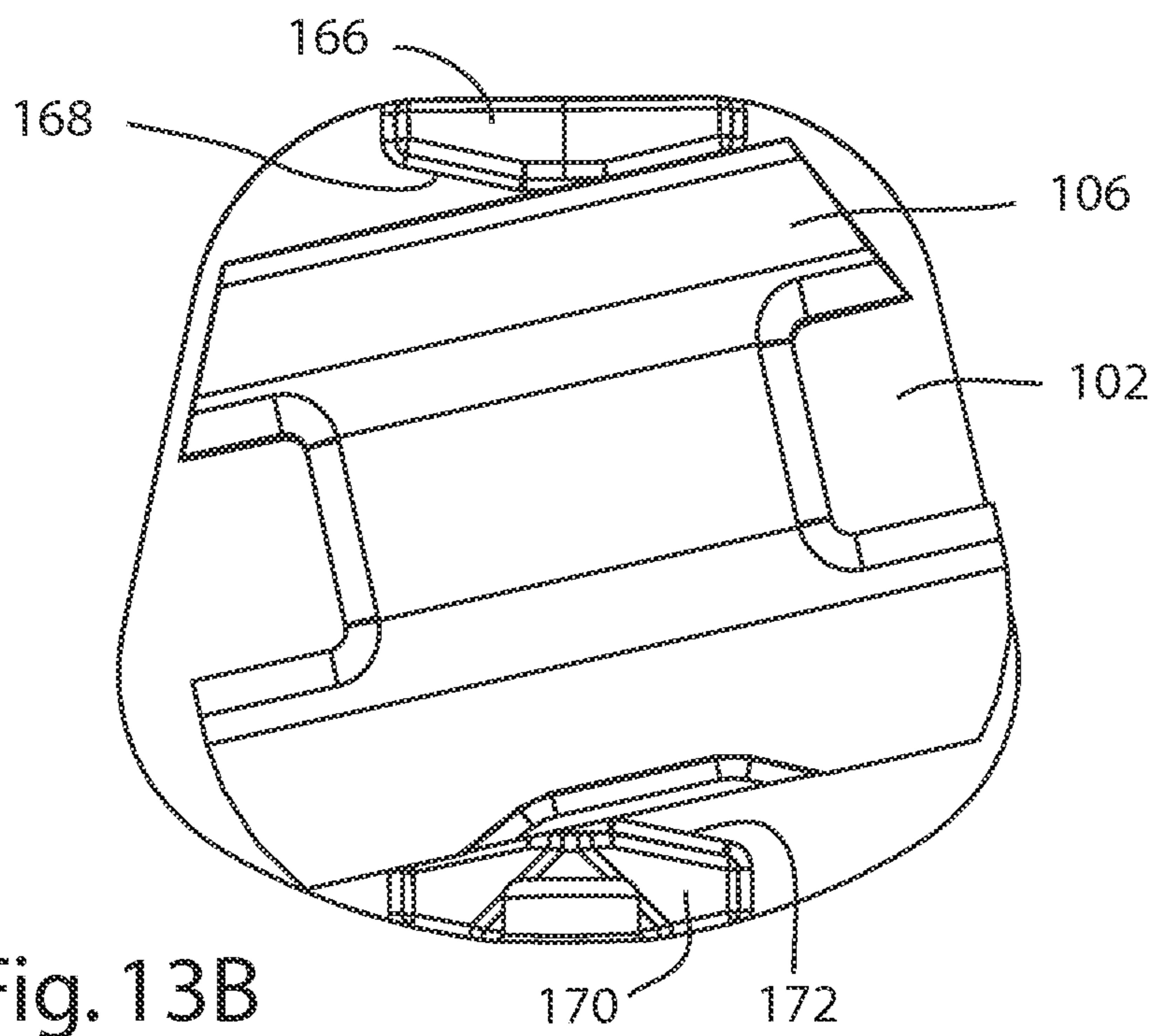

Fig. 13B



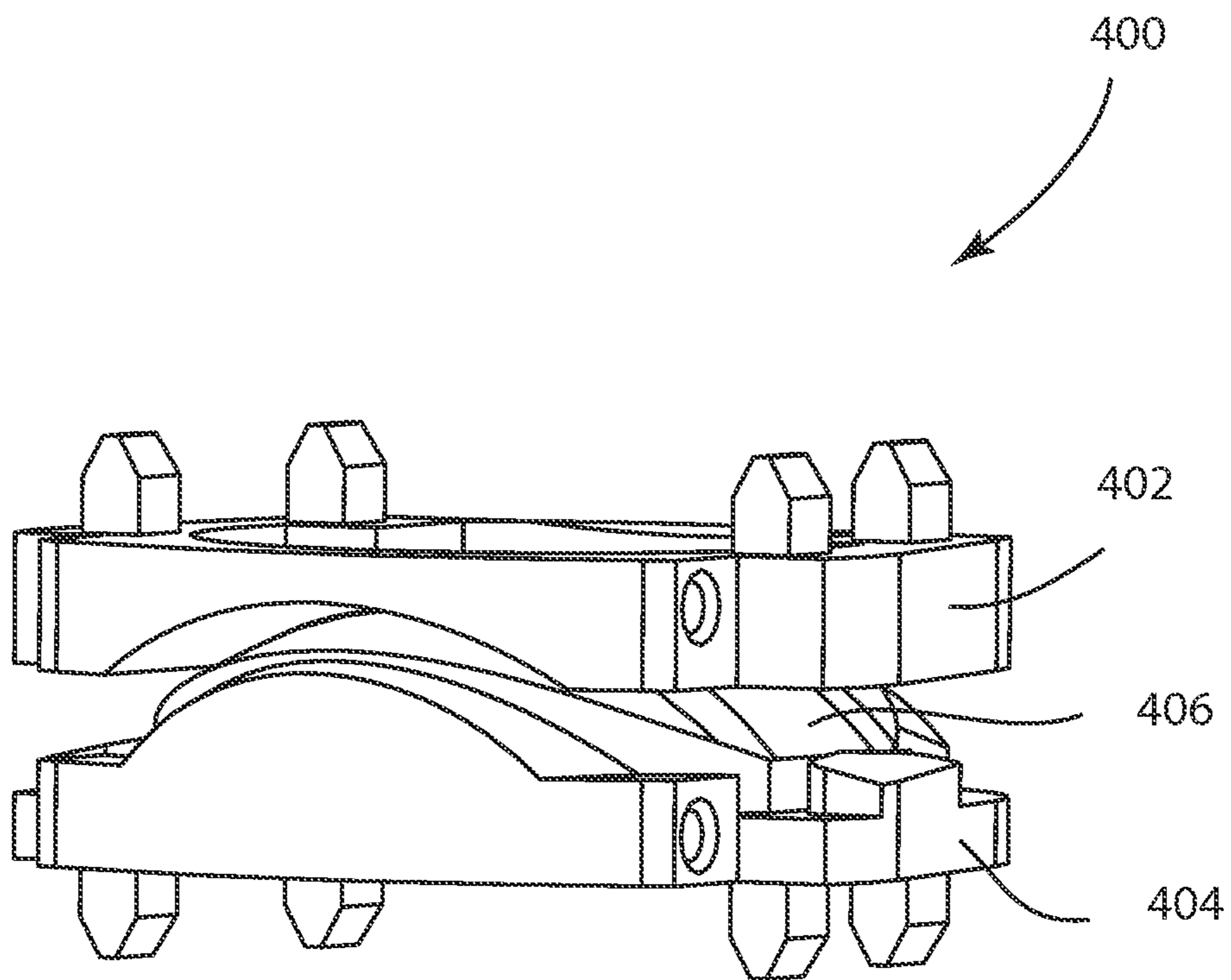

Fig. 14

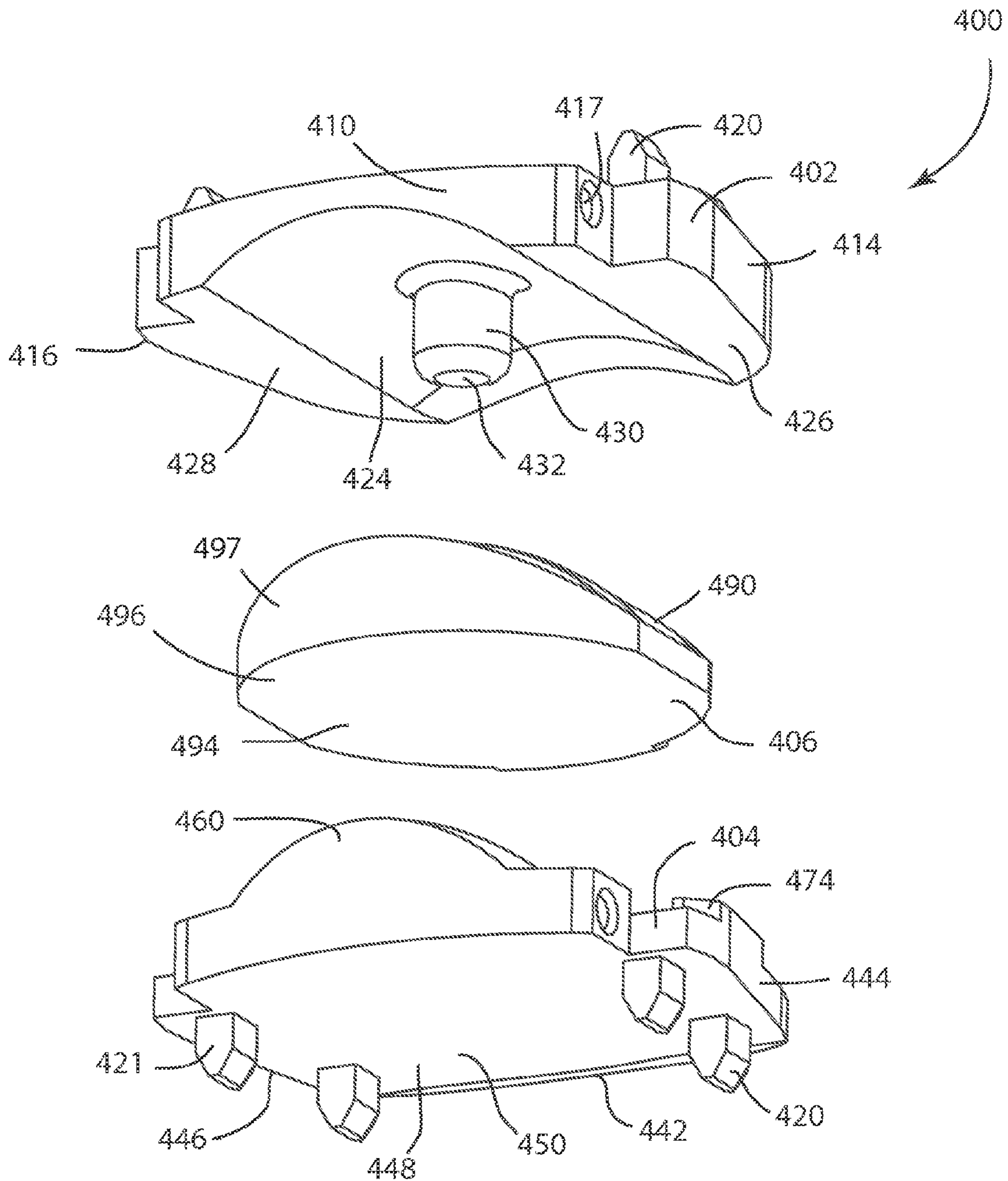

Fig. 15

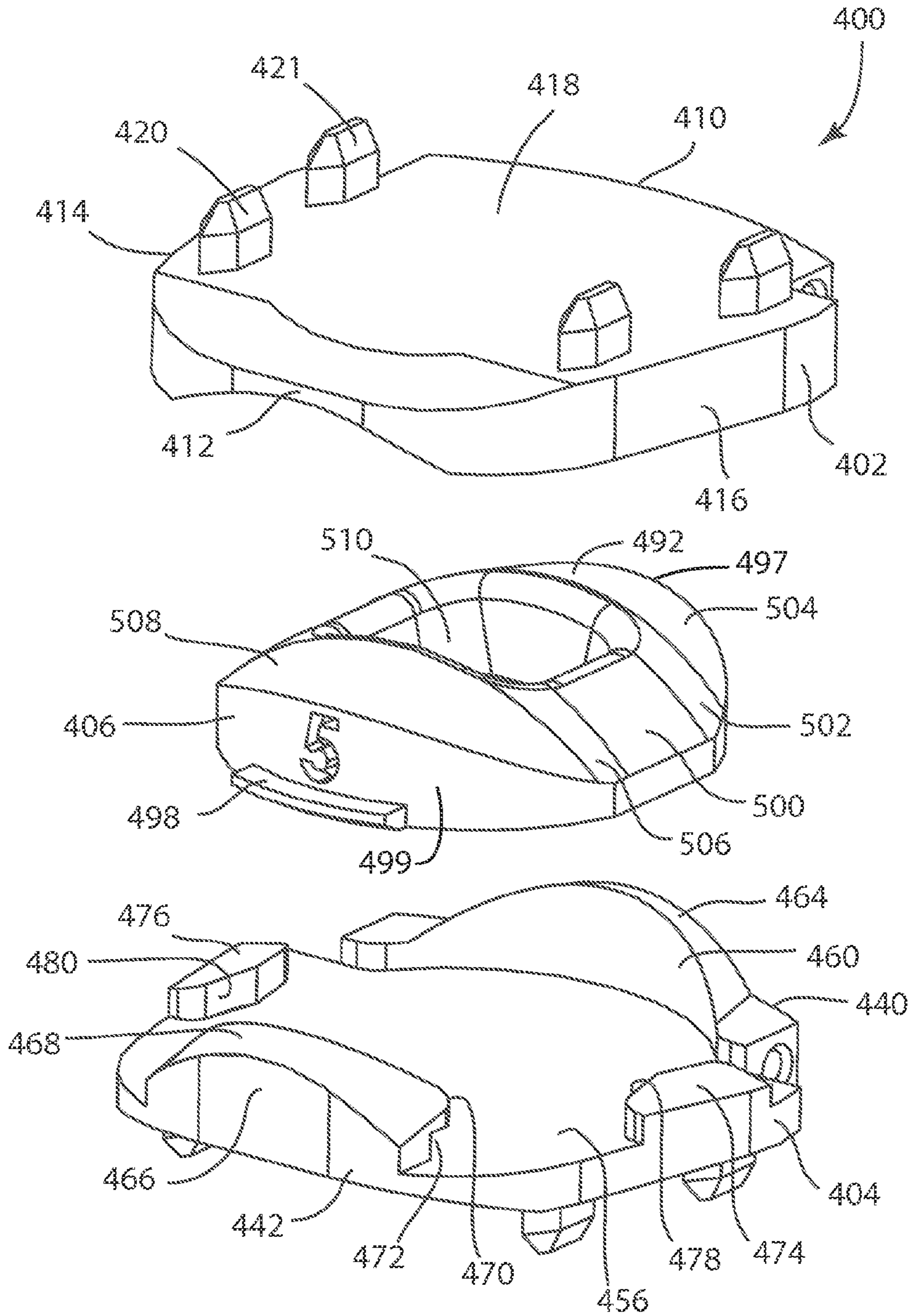

Fig. 16

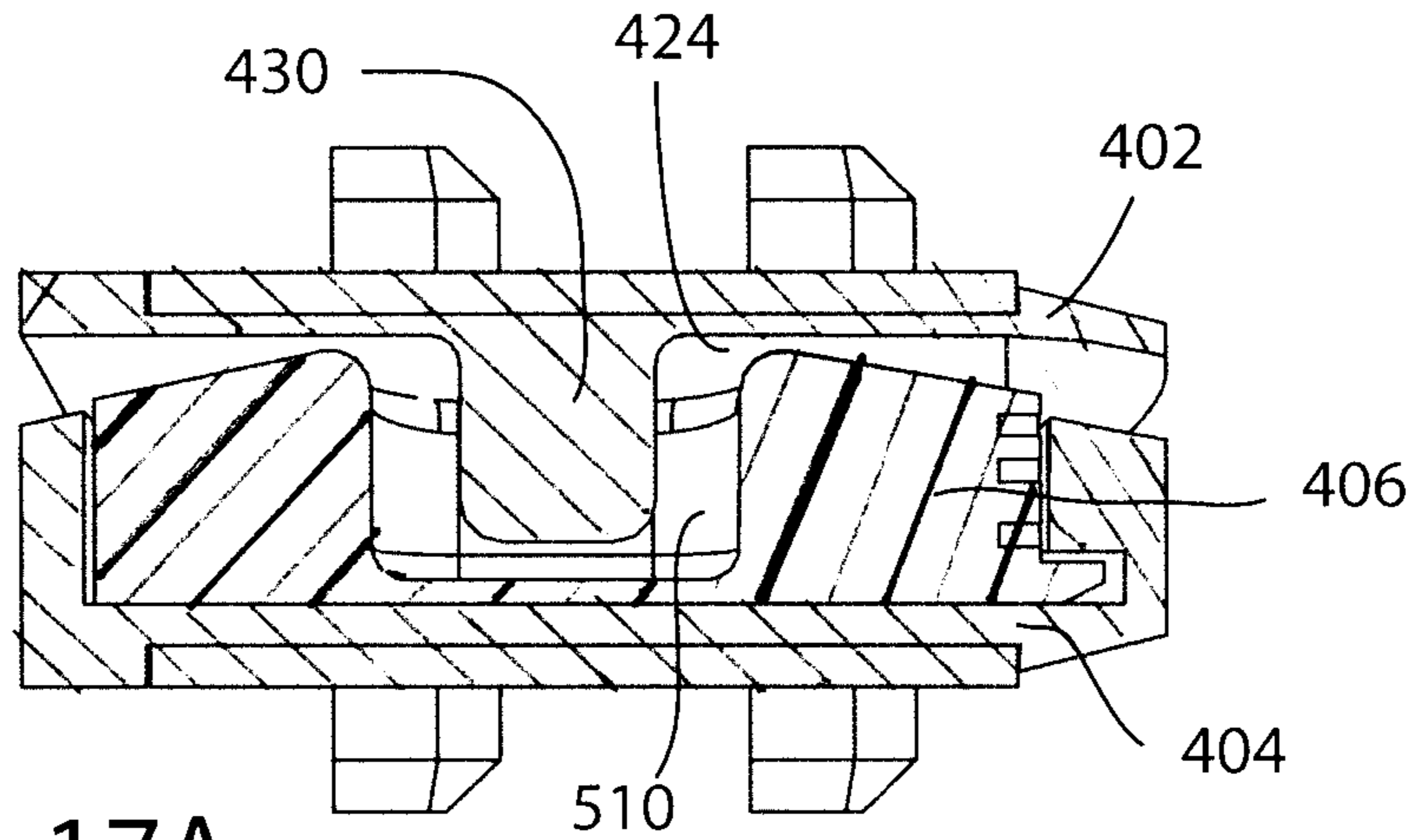

Fig. 17A

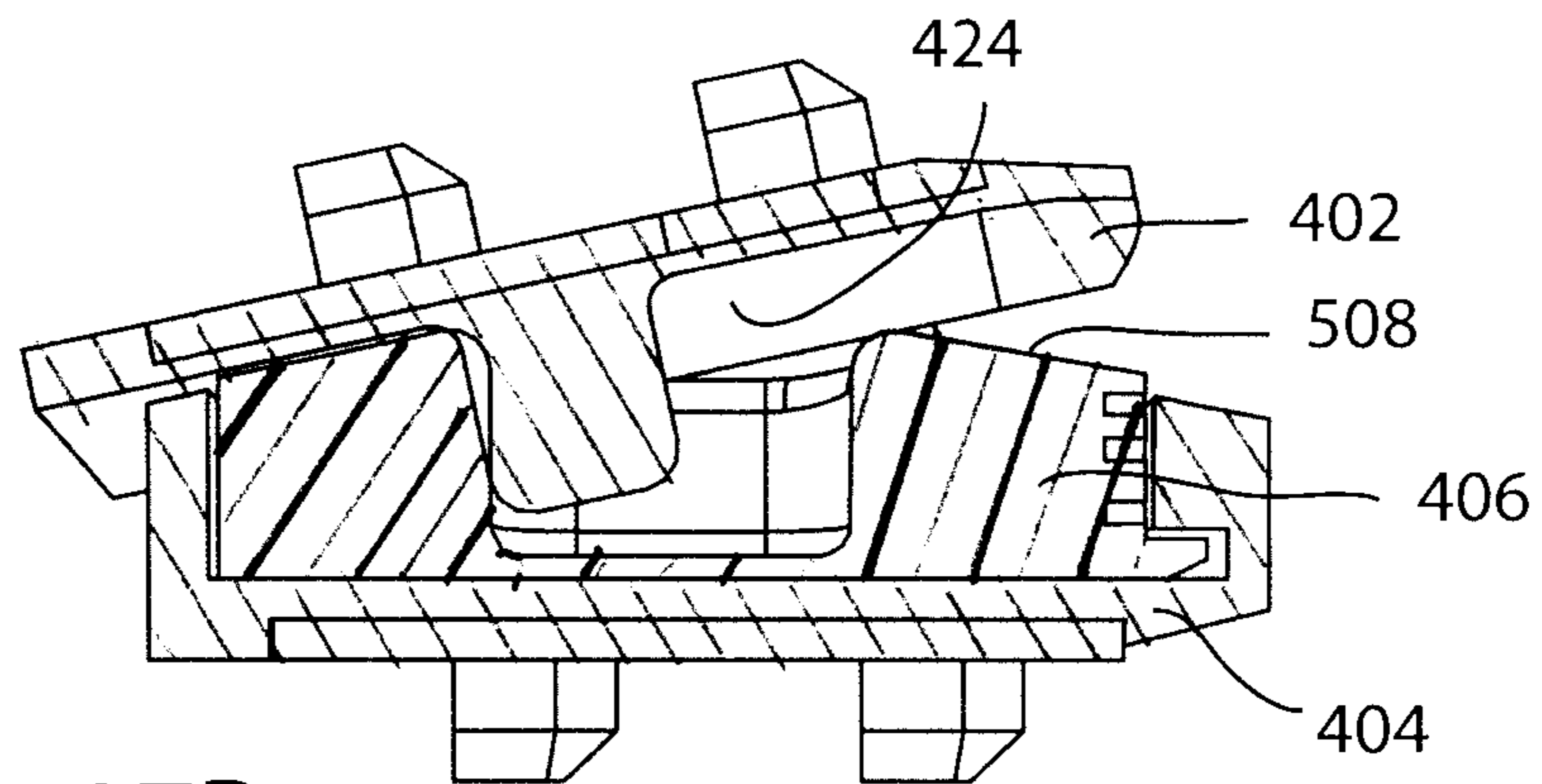

Fig. 17B

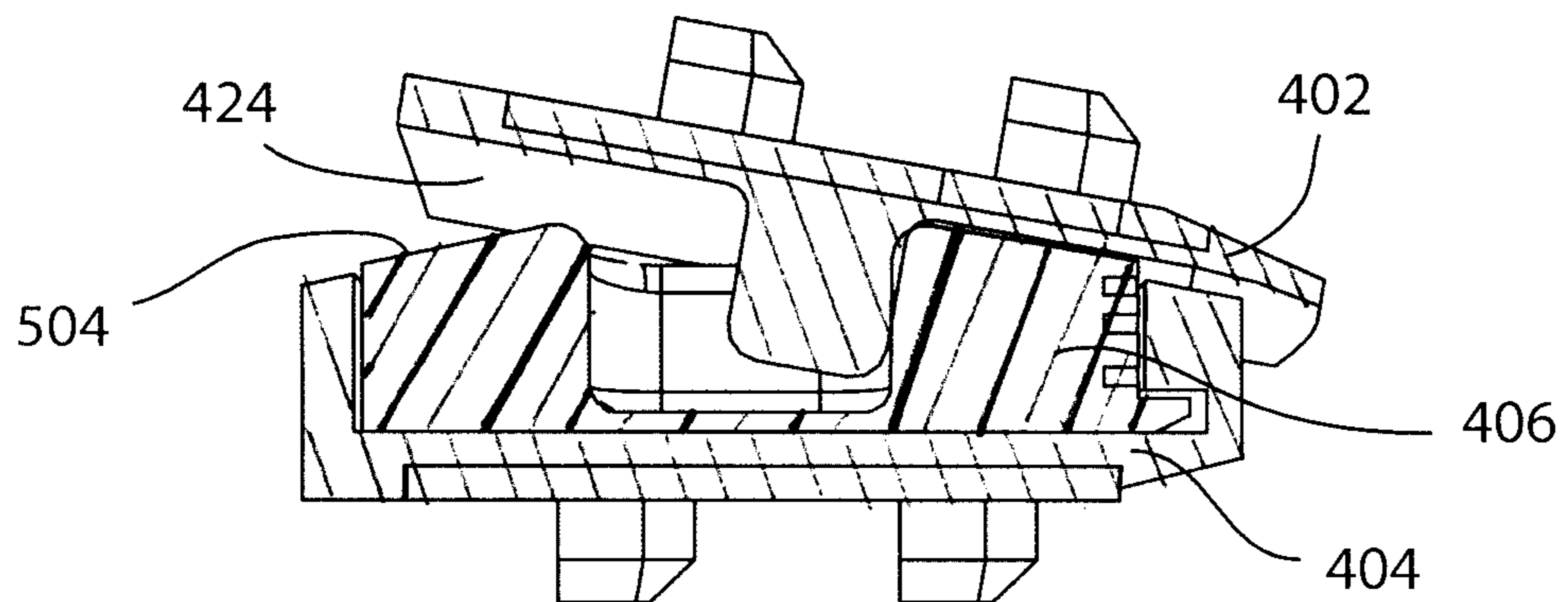

Fig. 17C

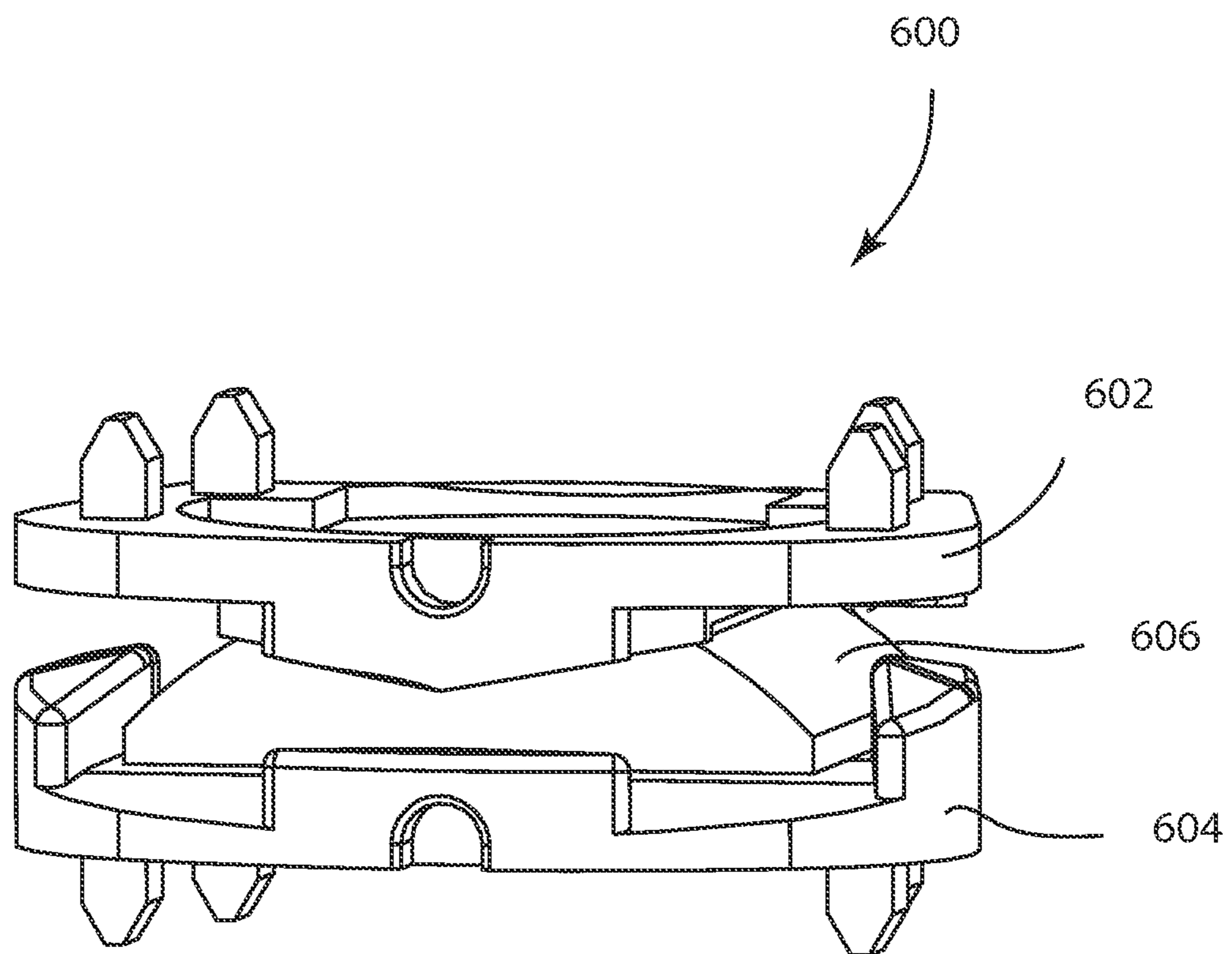

Fig. 18

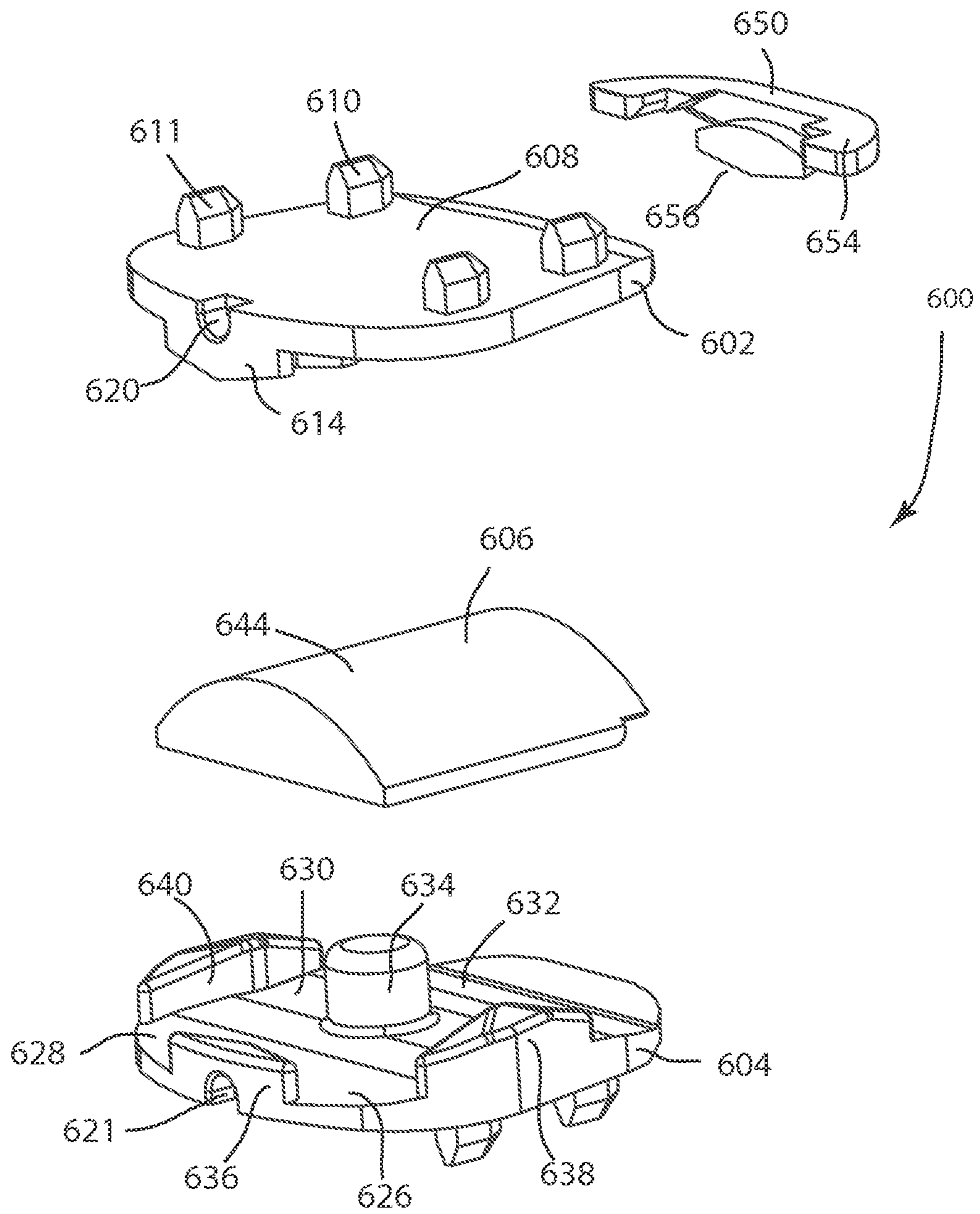

Fig. 19

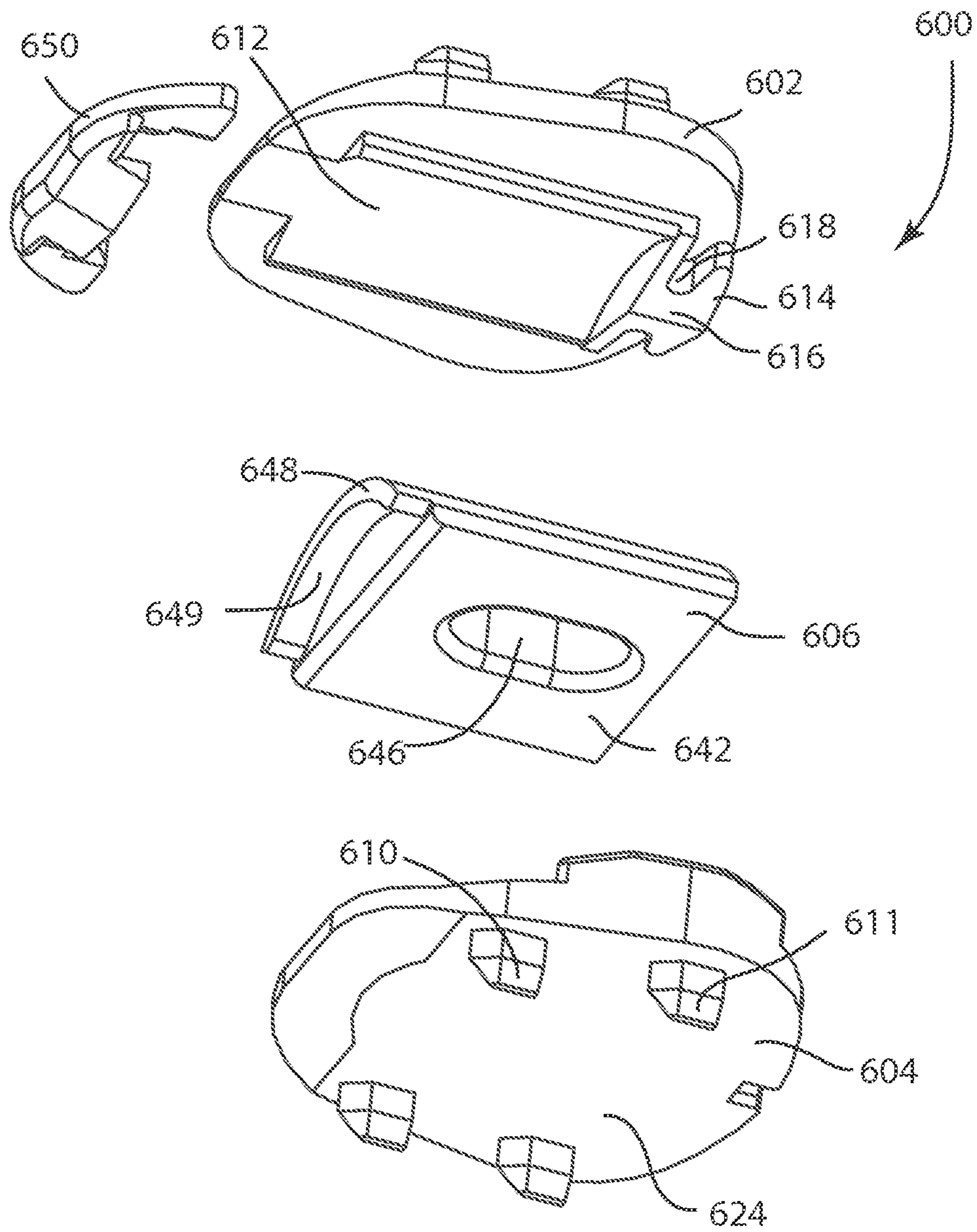

Fig. 20

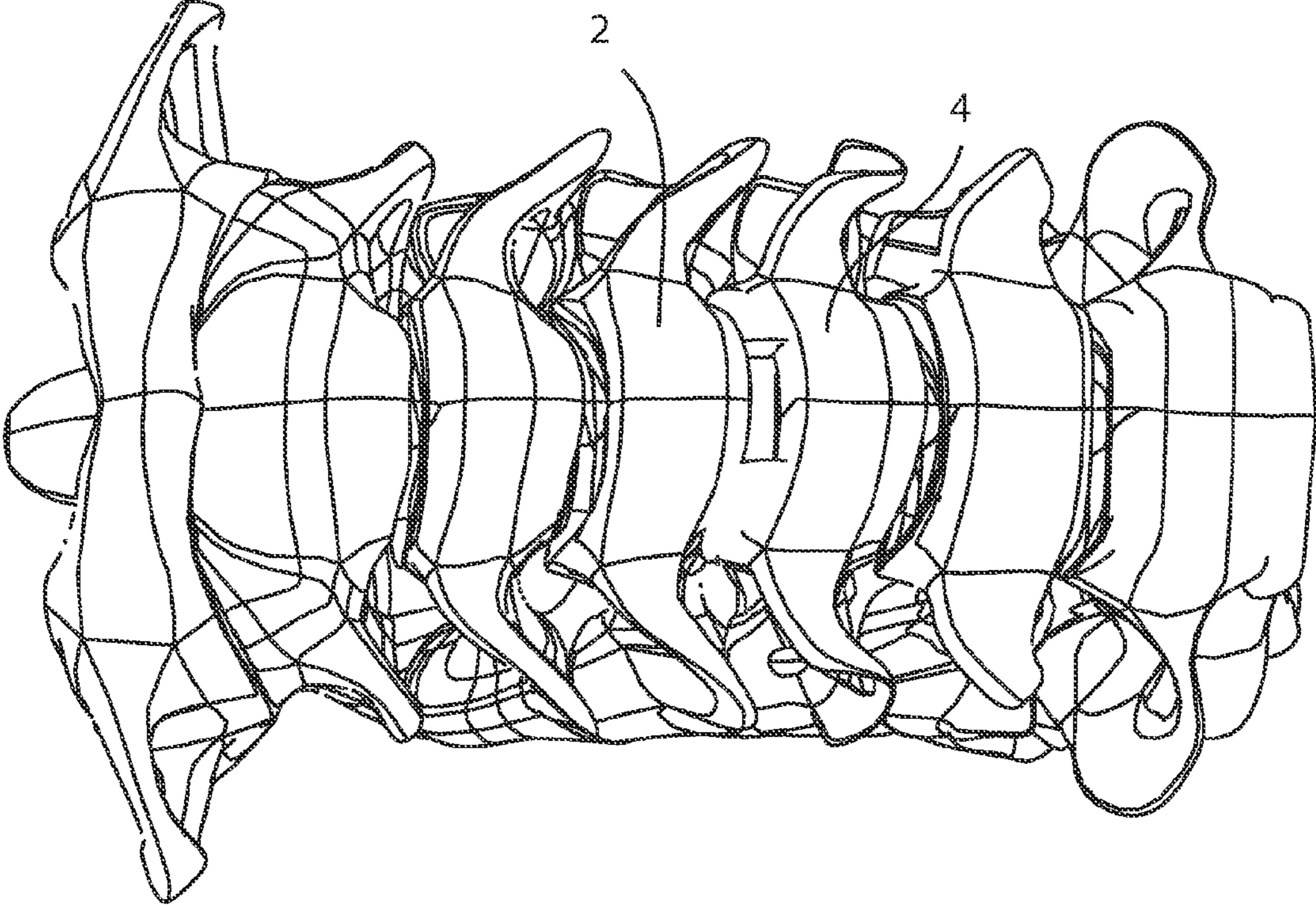

Fig. 21



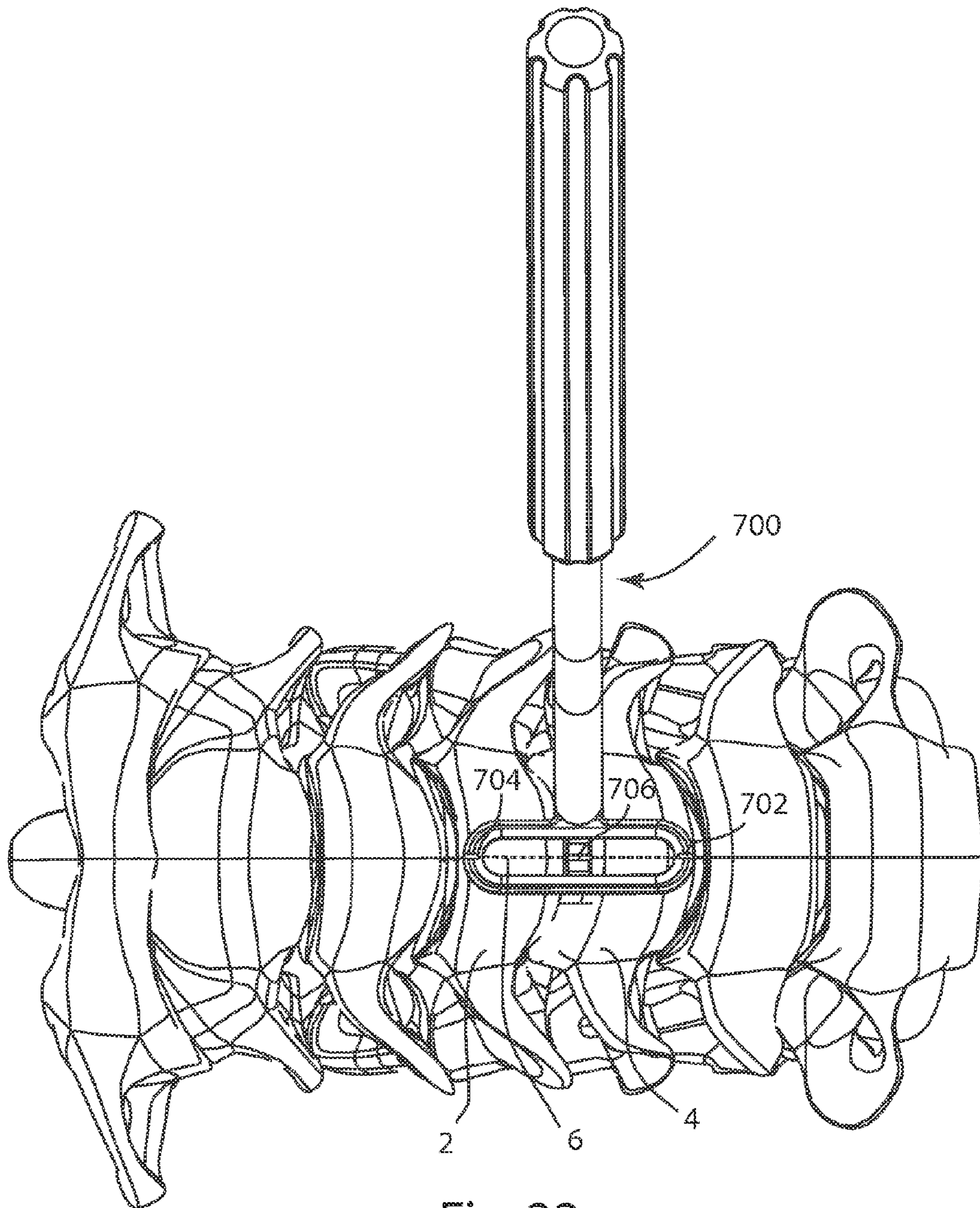
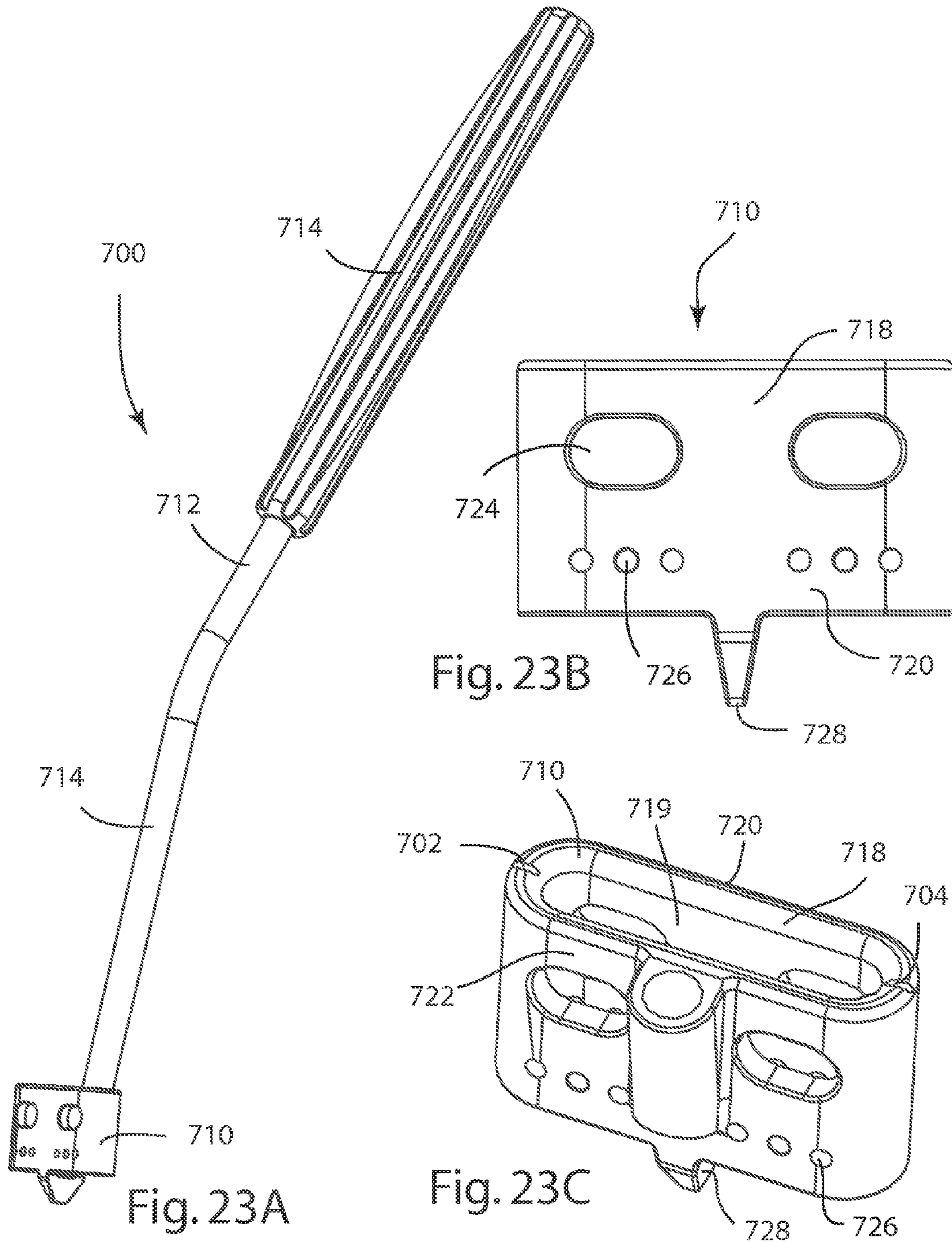

Fig. 22



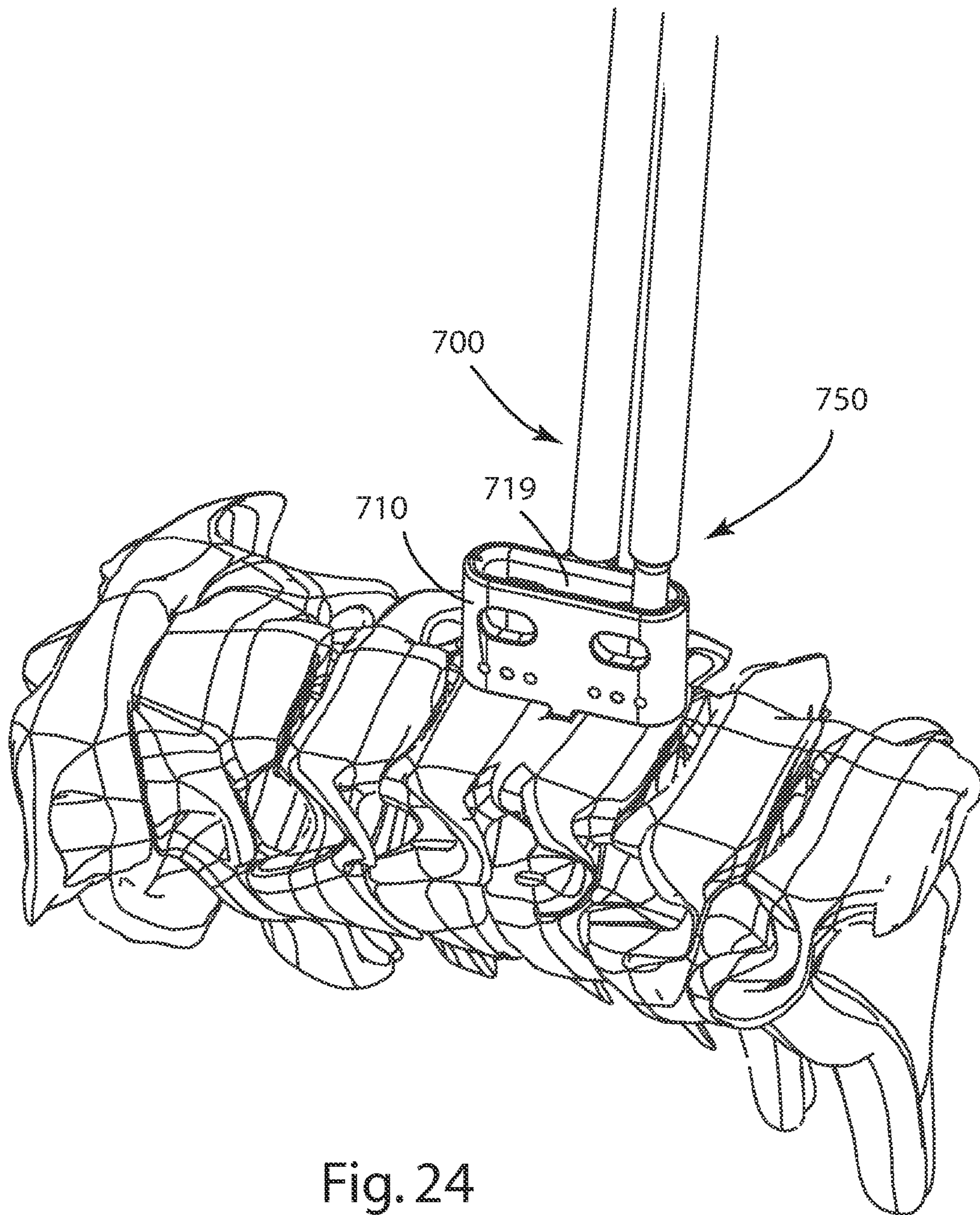

Fig. 24

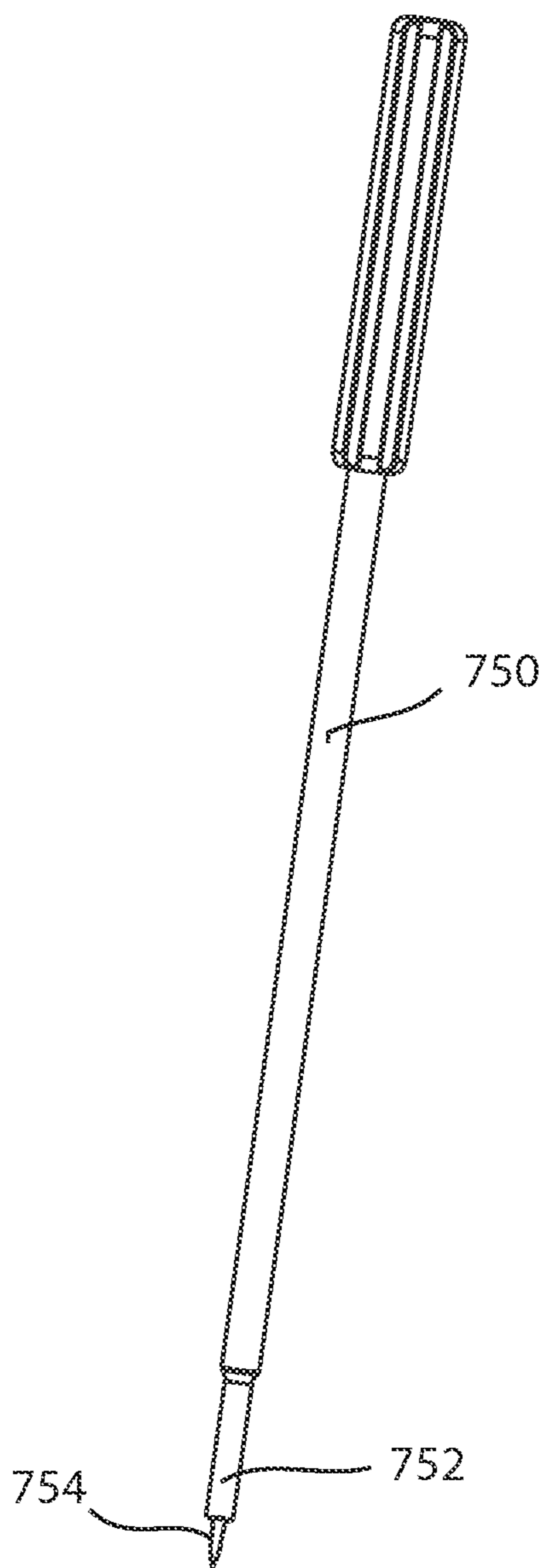

Fig. 25

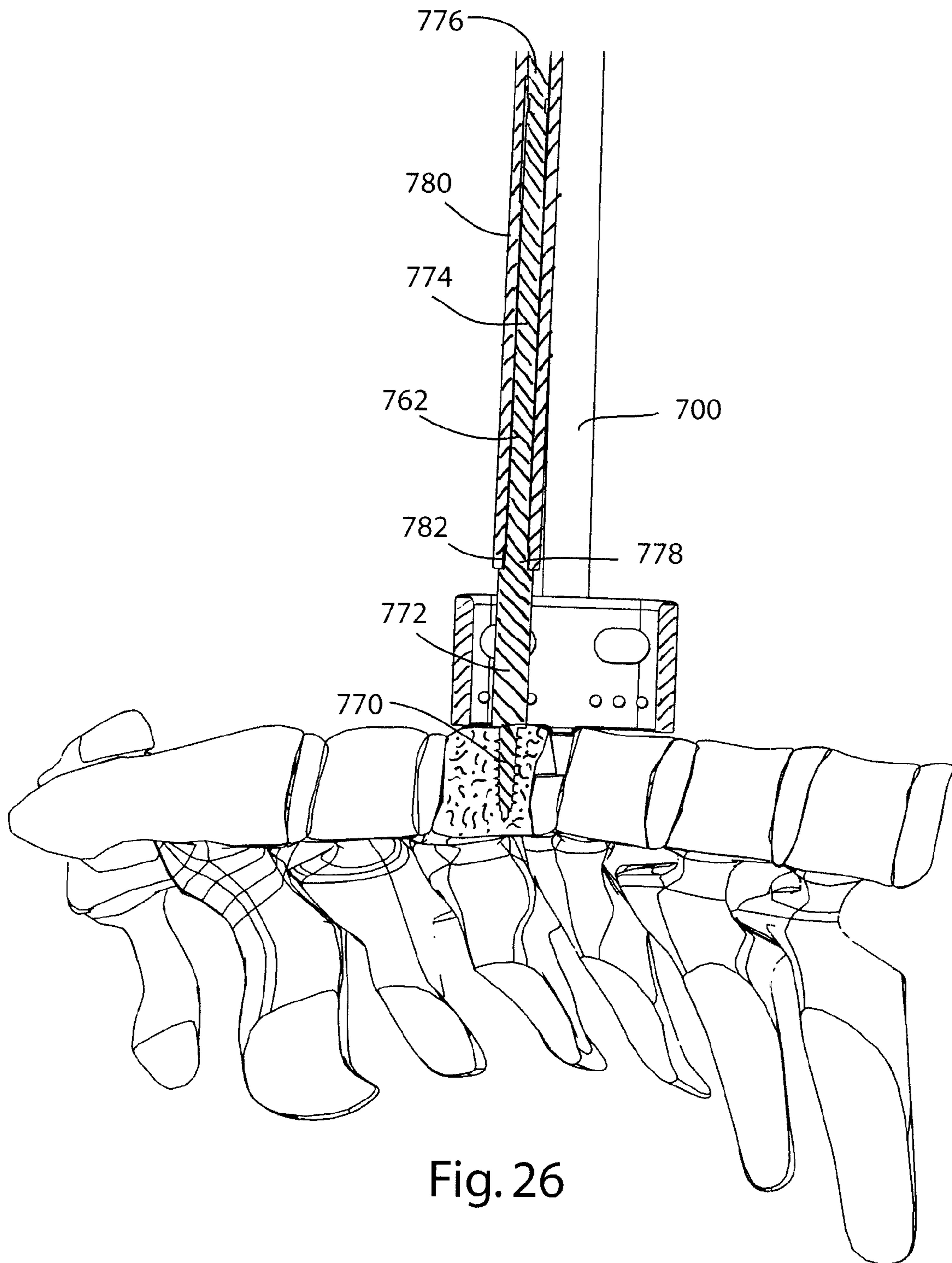

Fig. 26

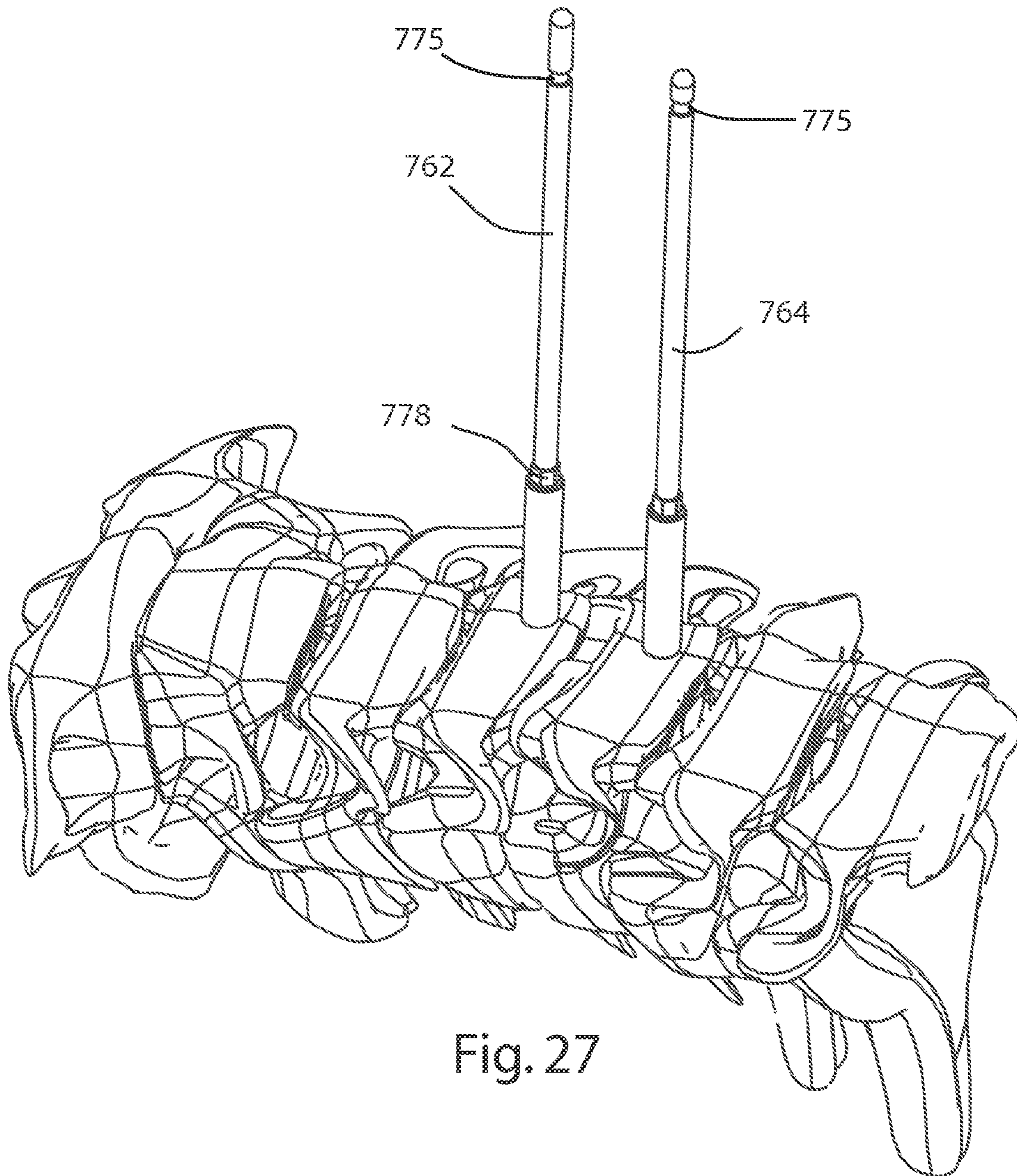

Fig. 27

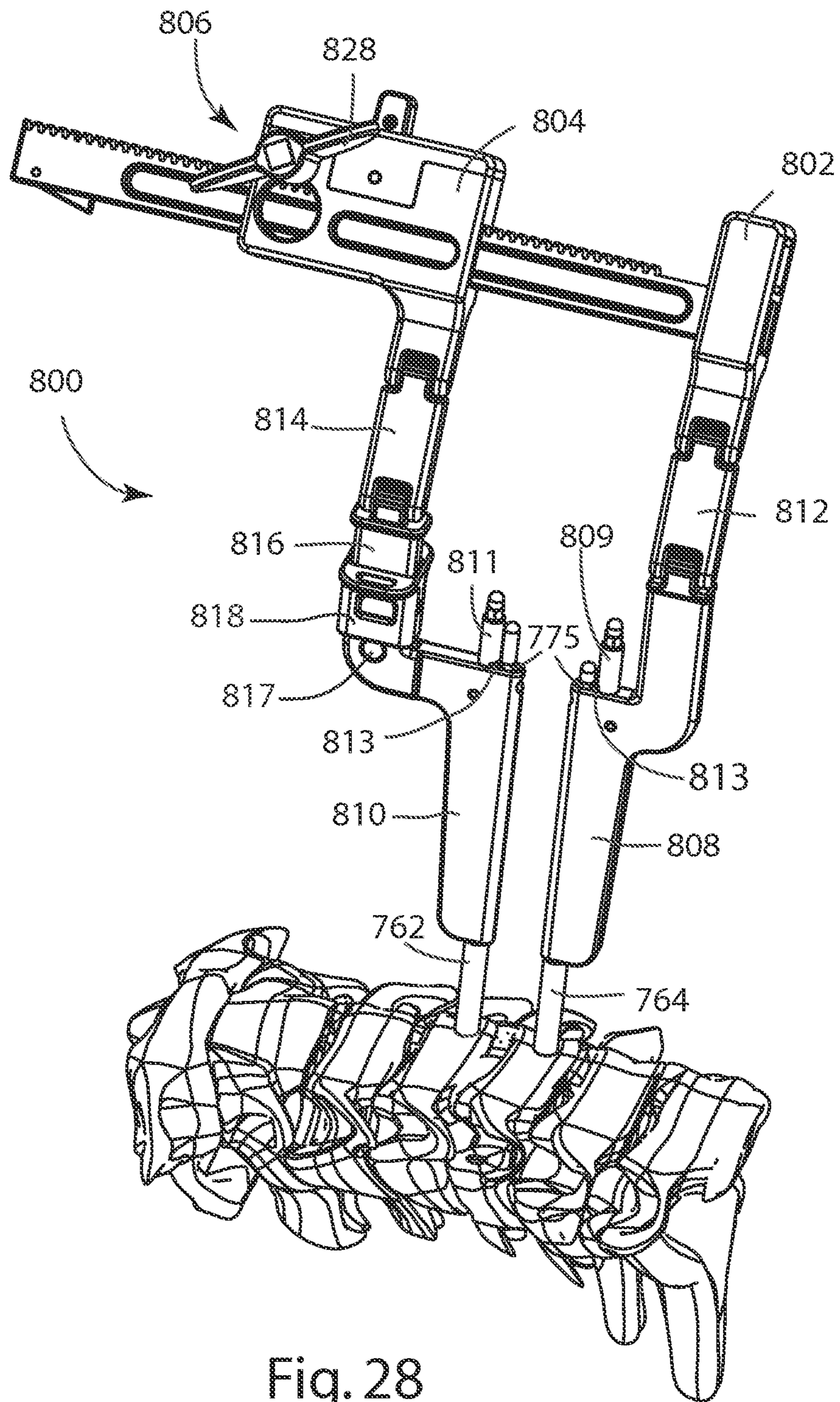

Fig. 28

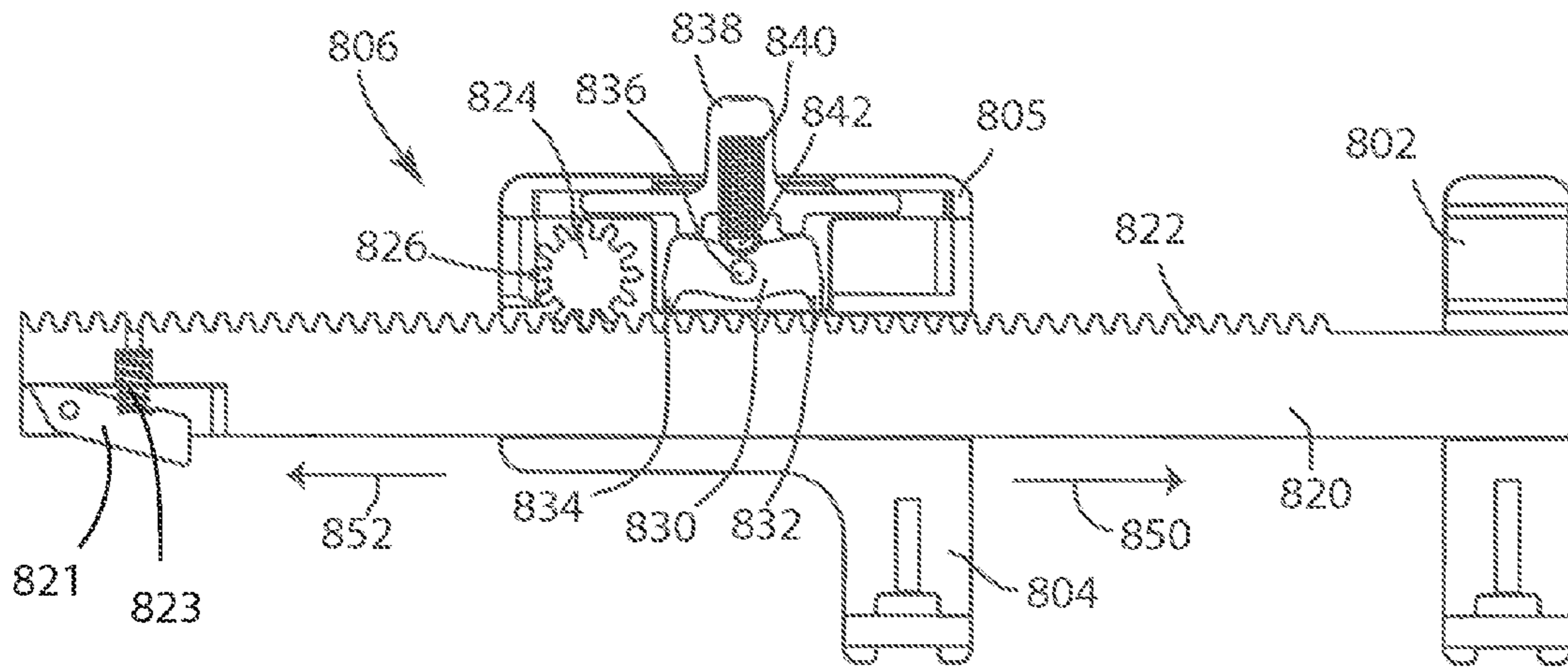

Fig. 29A

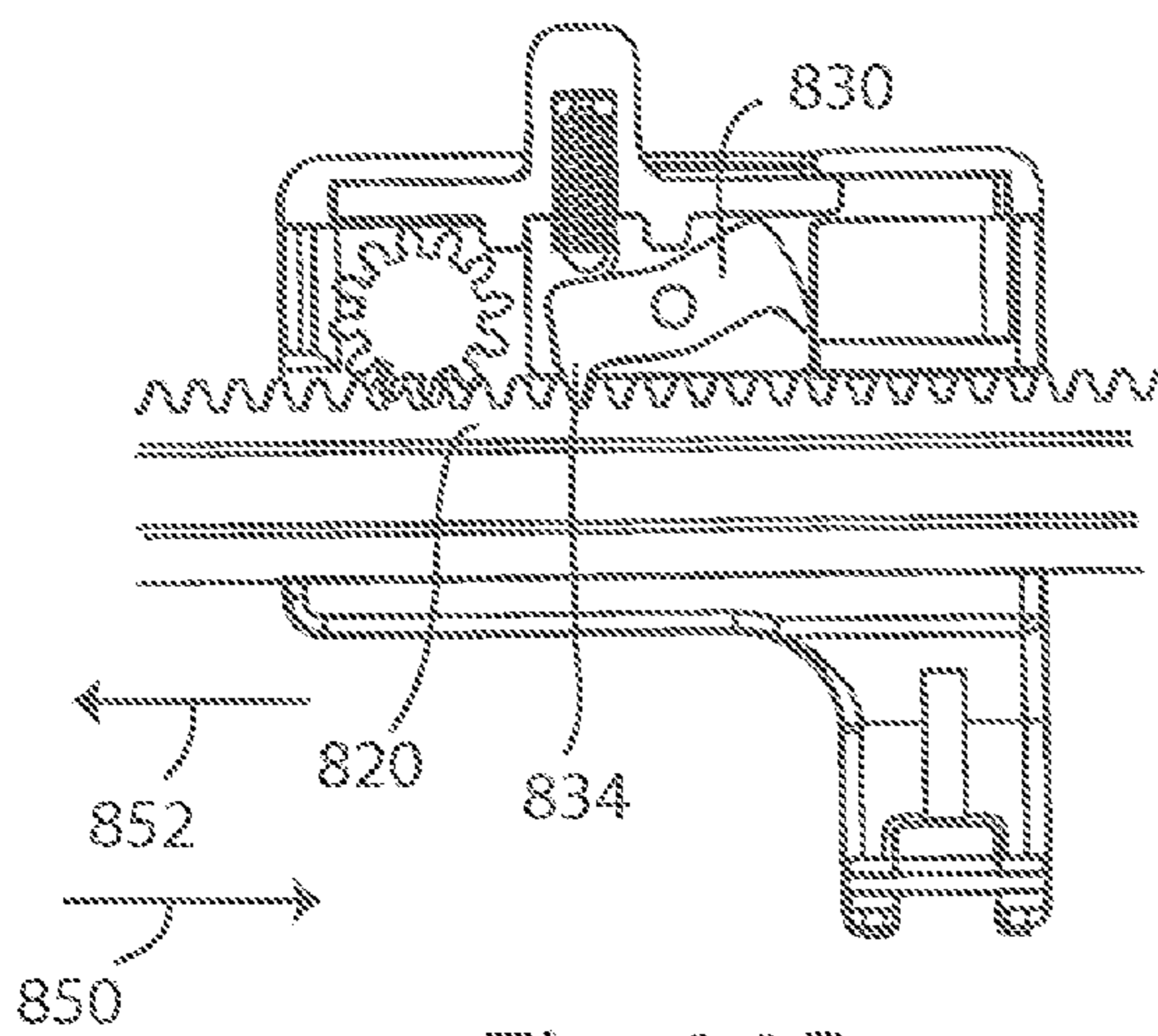

Fig. 29B

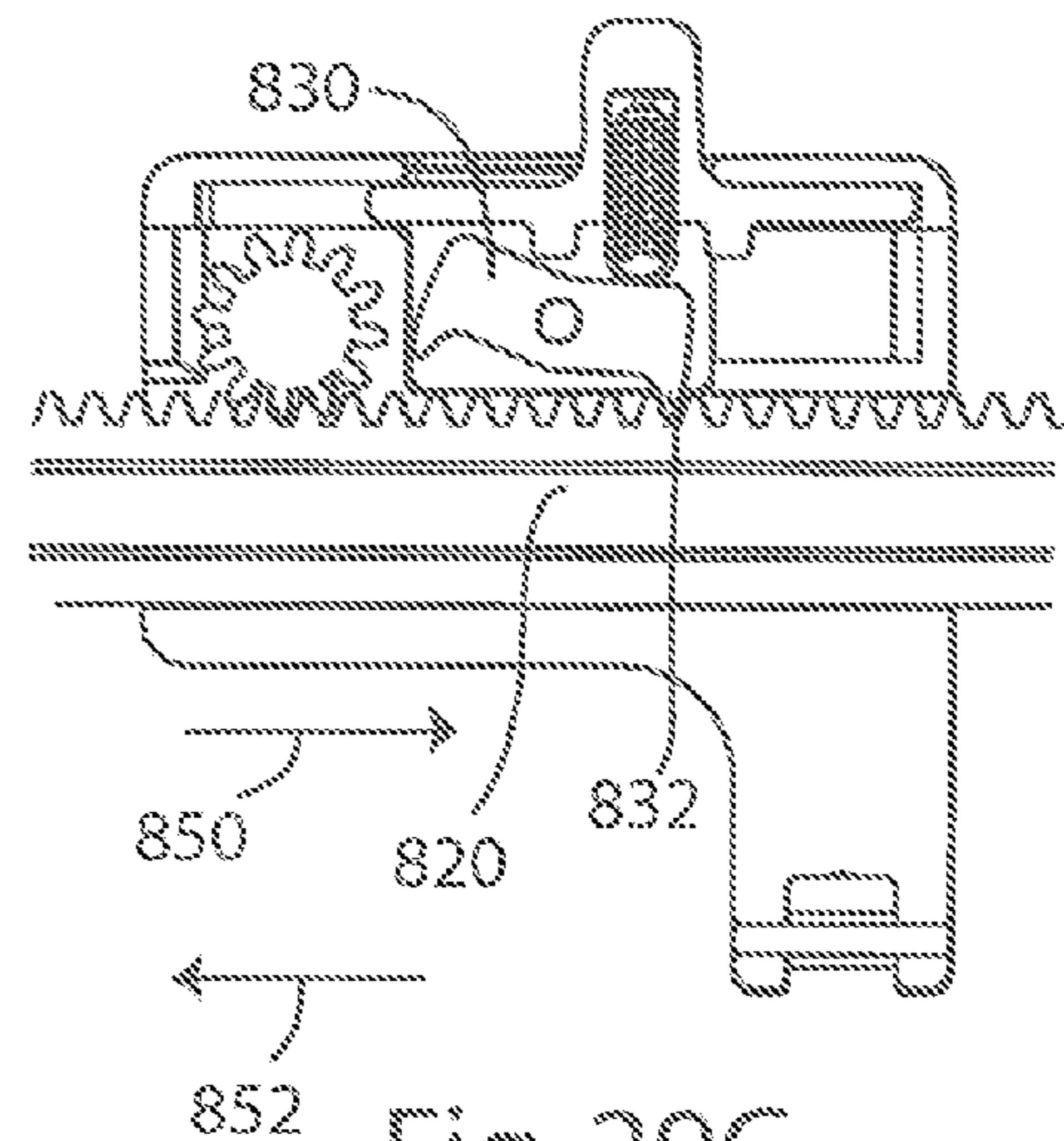

Fig. 29C



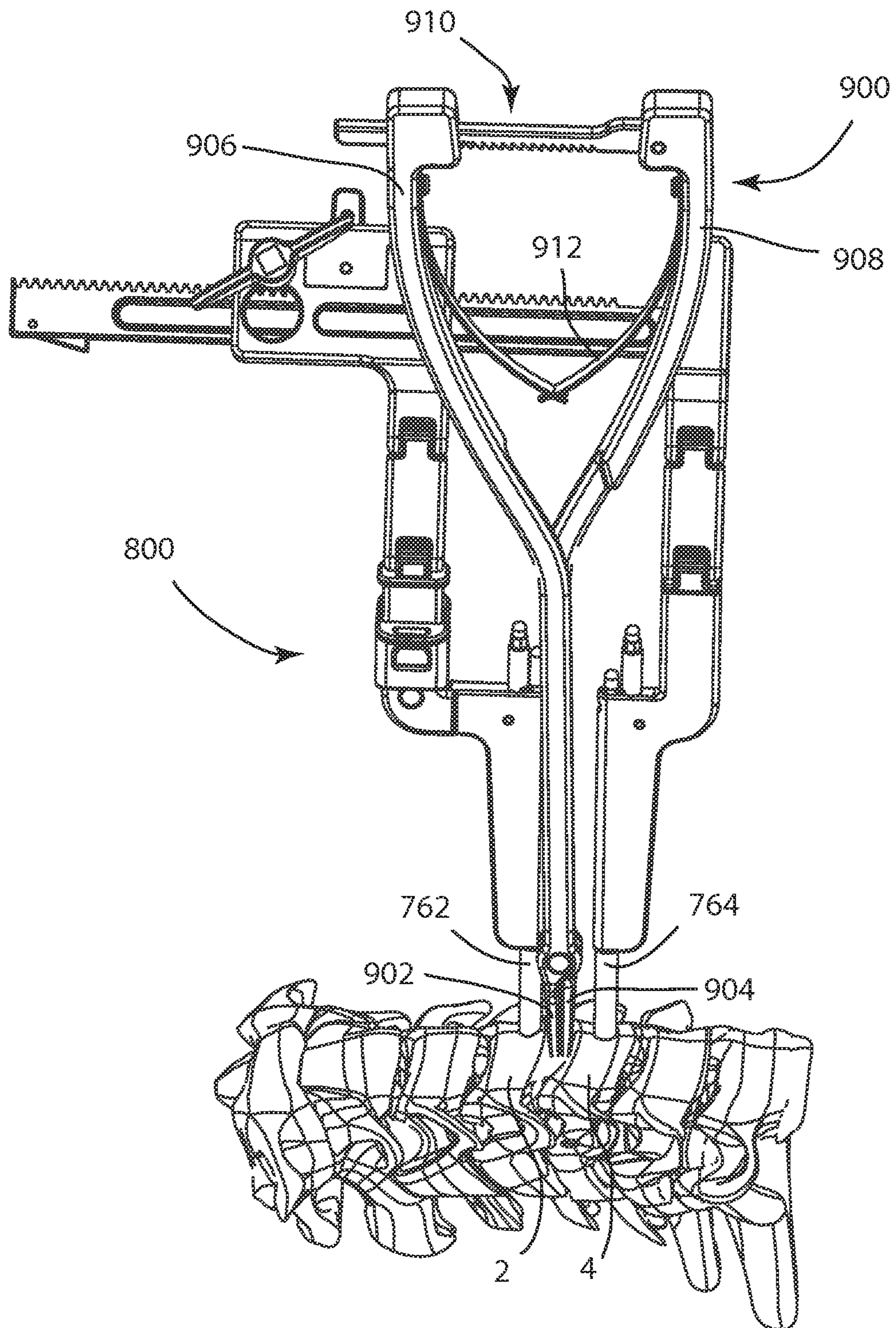

Fig. 30

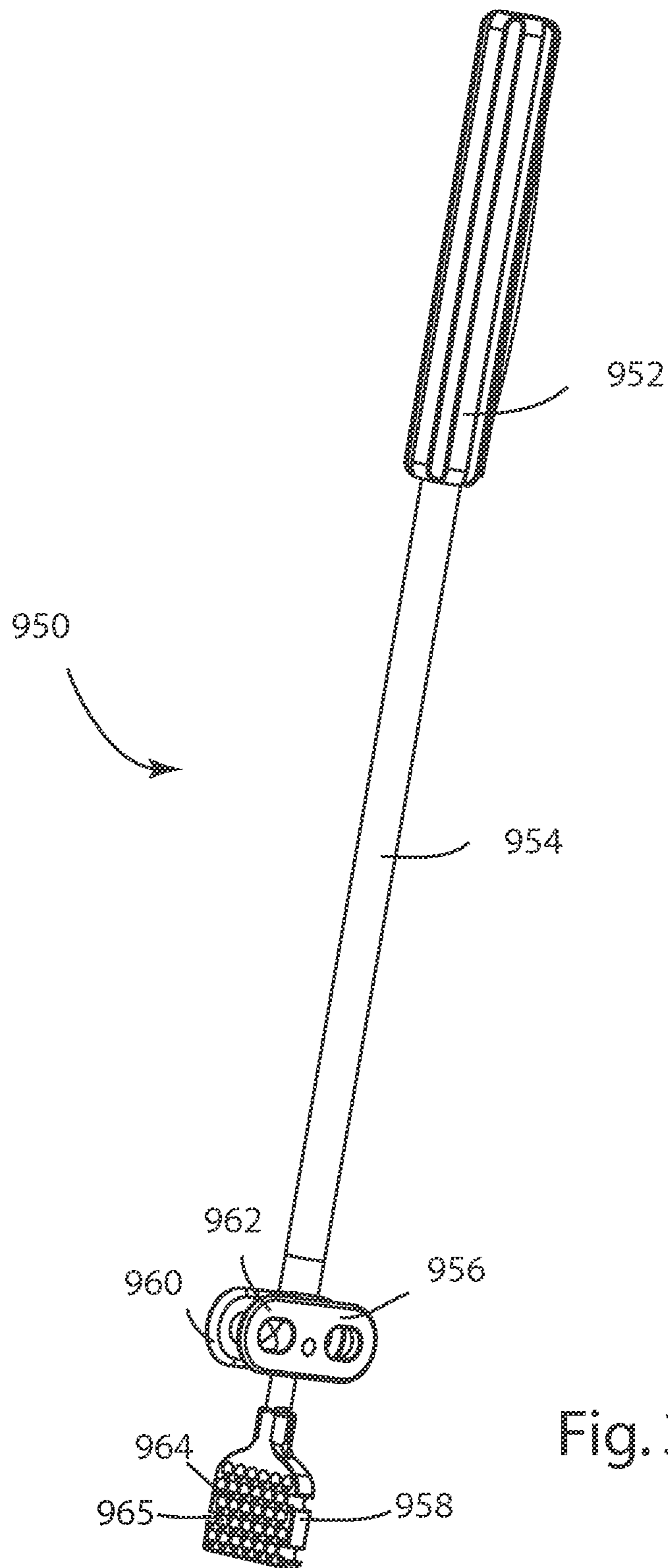

Fig. 31

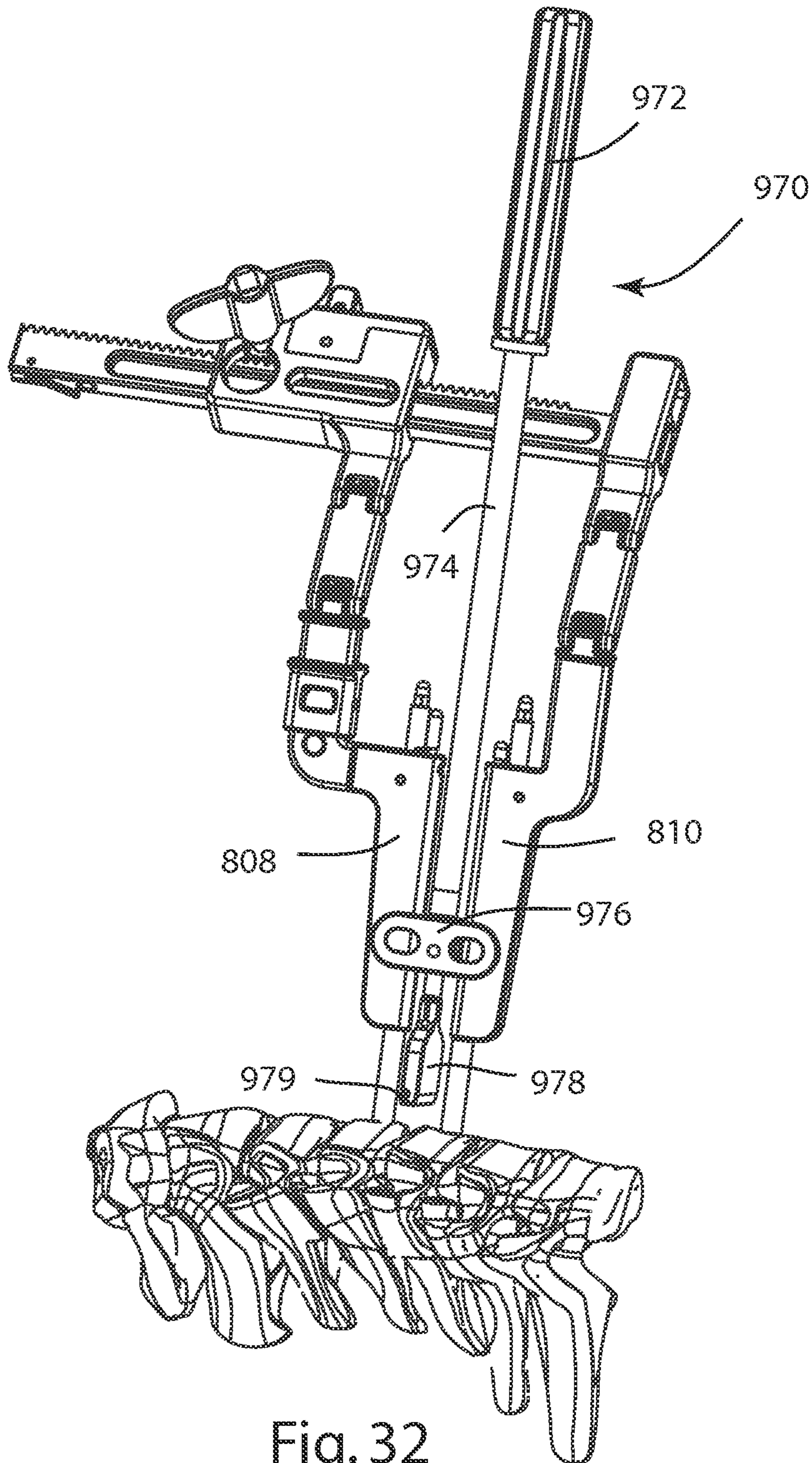

Fig. 32

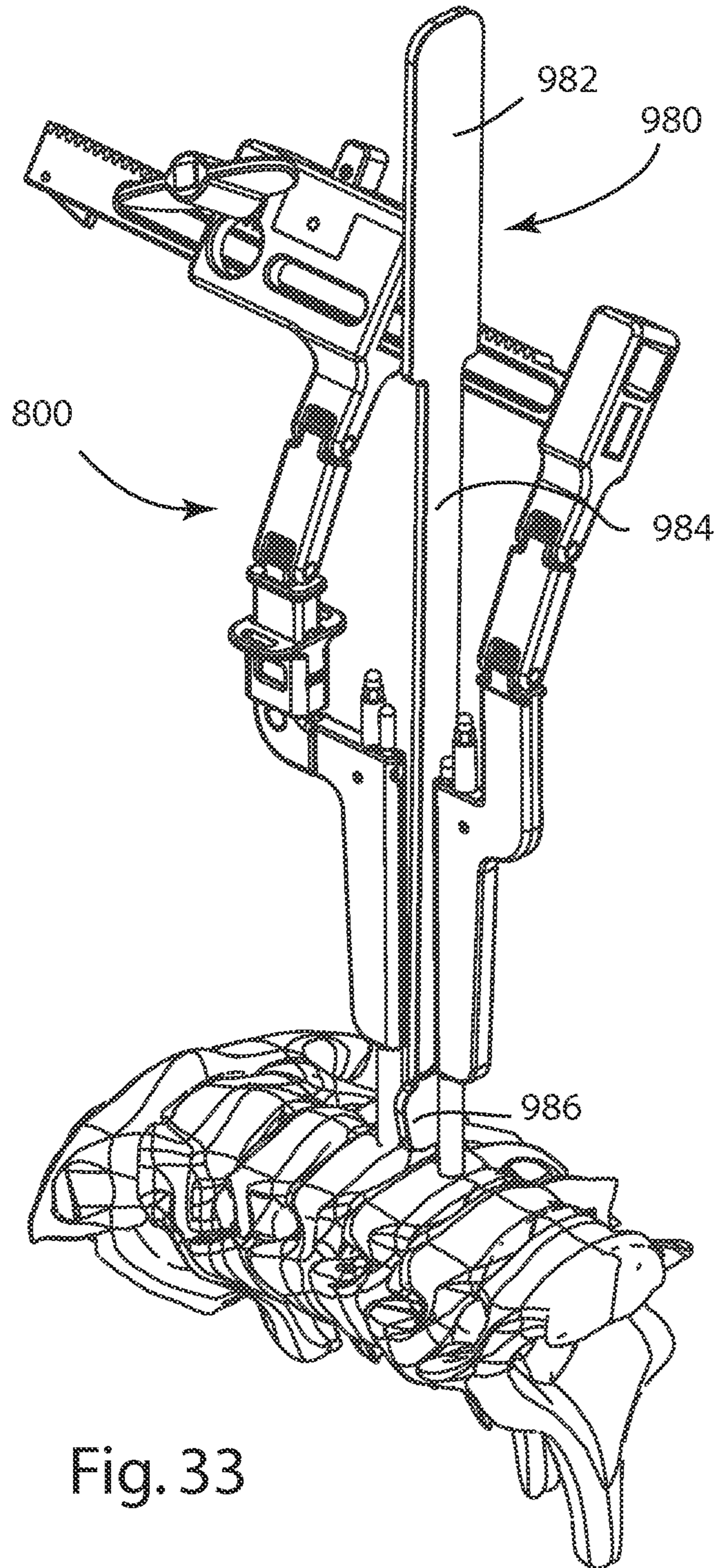

Fig. 33

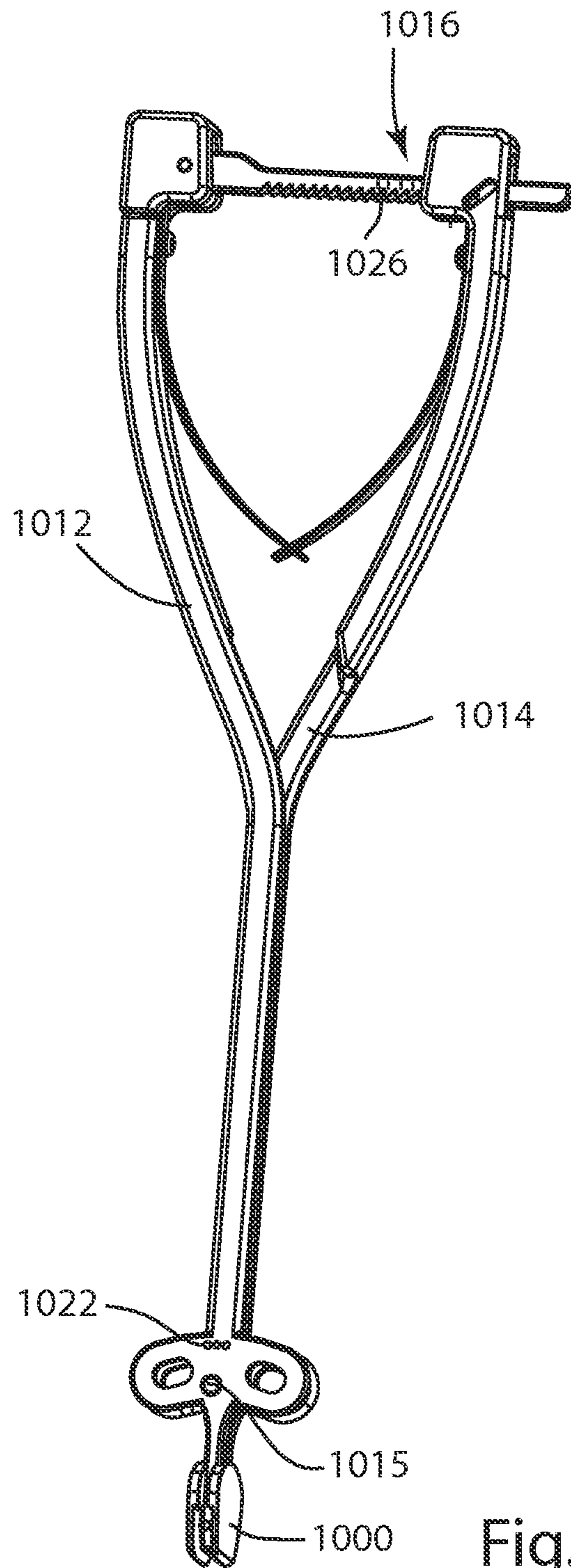

Fig. 34

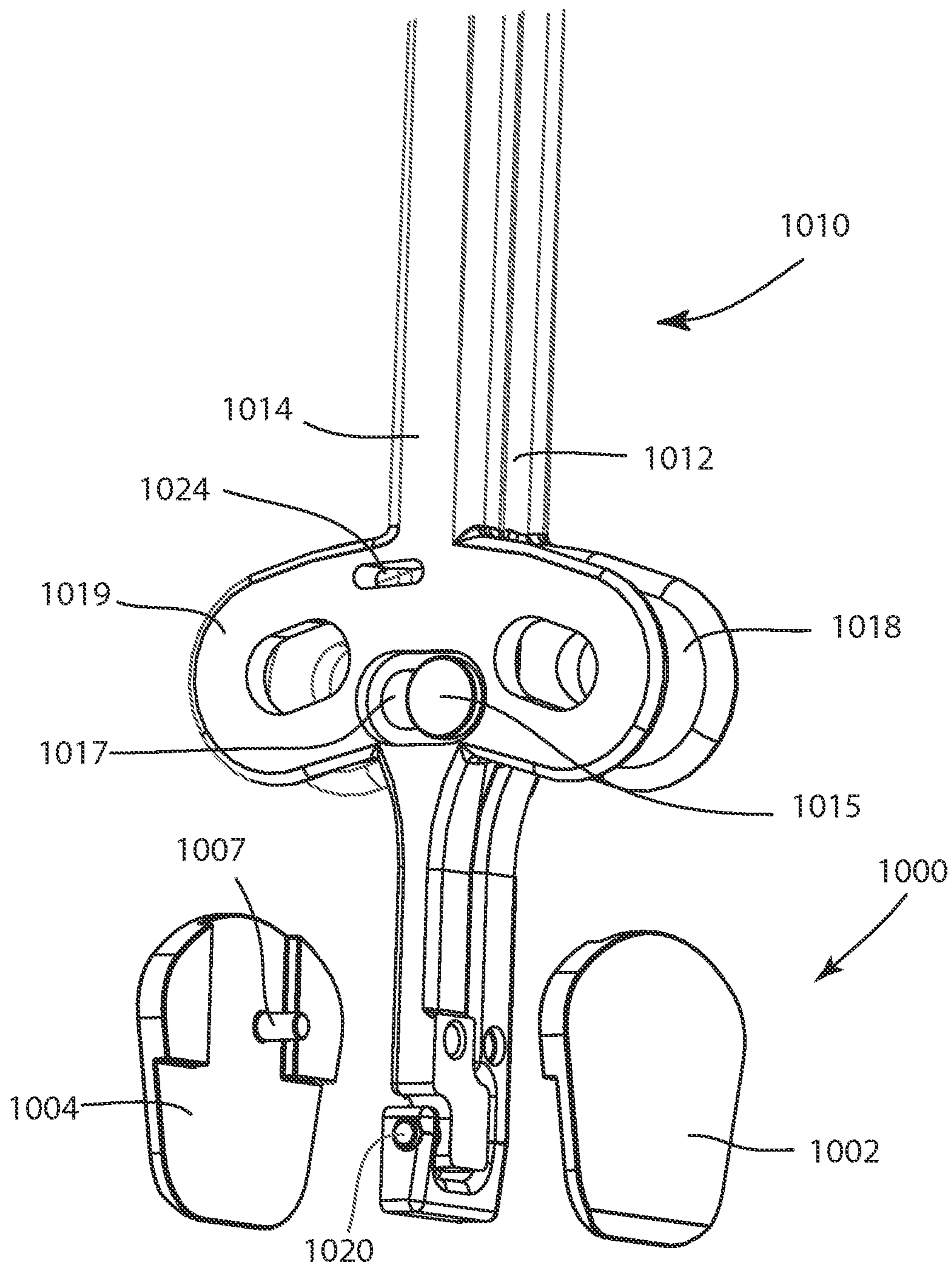

Fig. 35

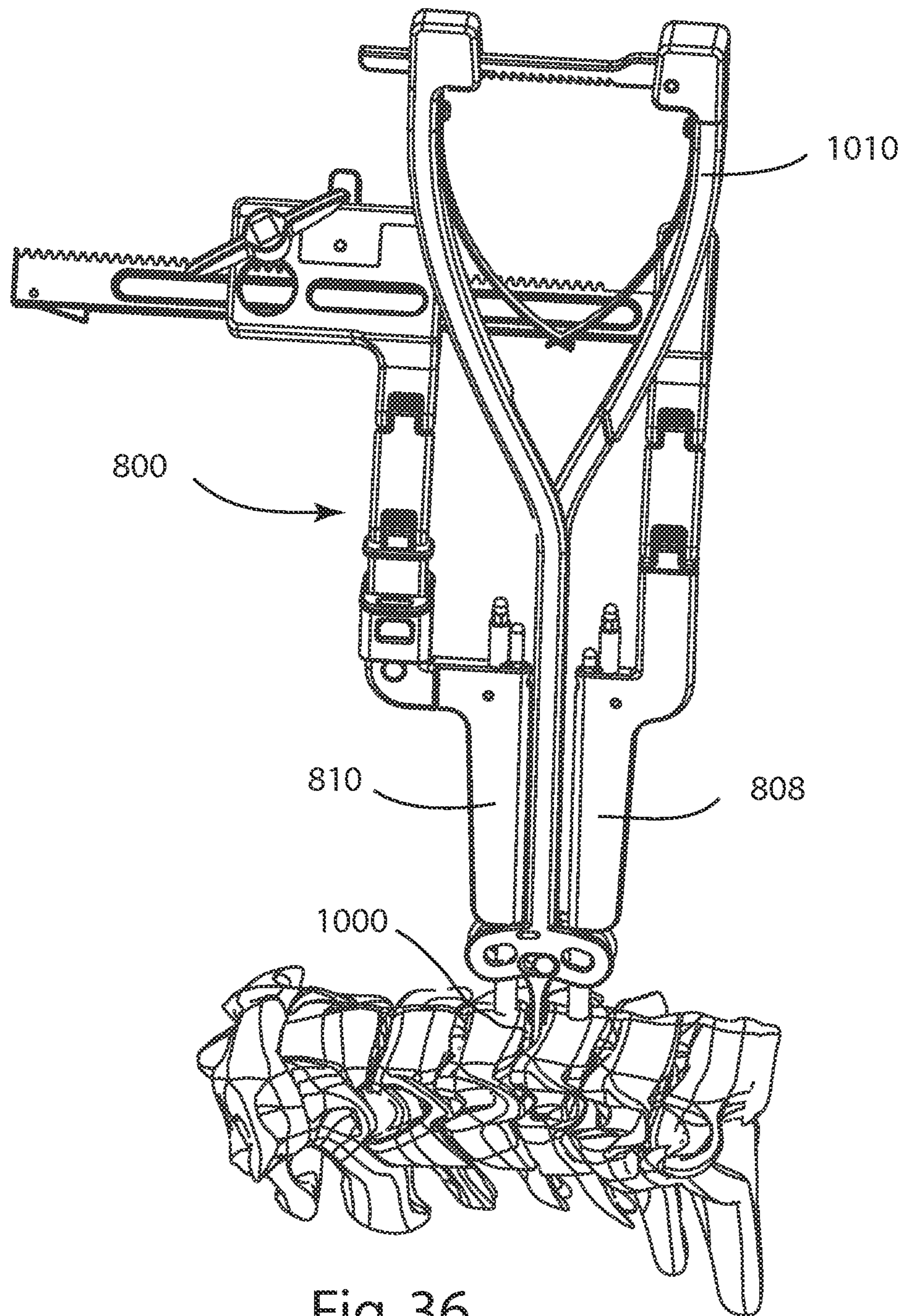

Fig. 36

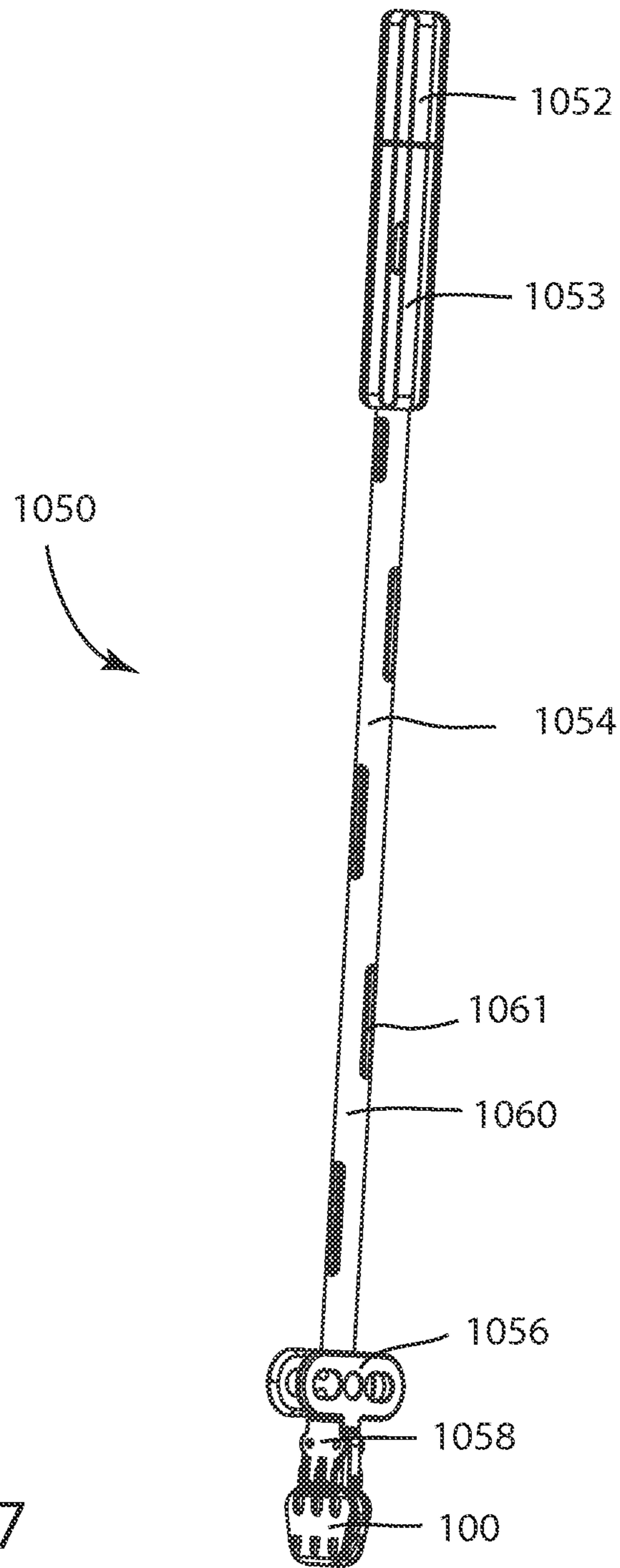

Fig. 37



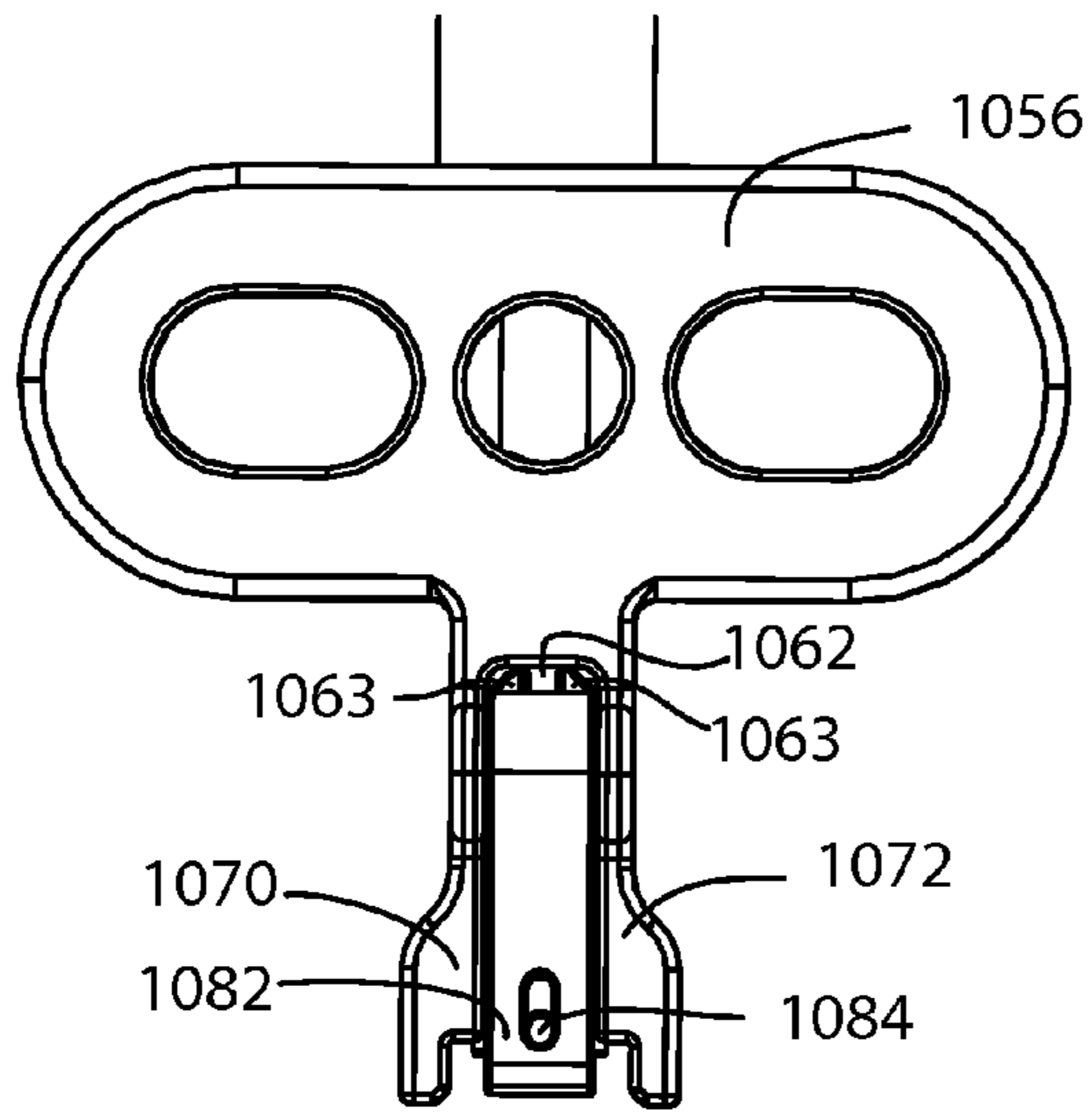

Fig. 38A

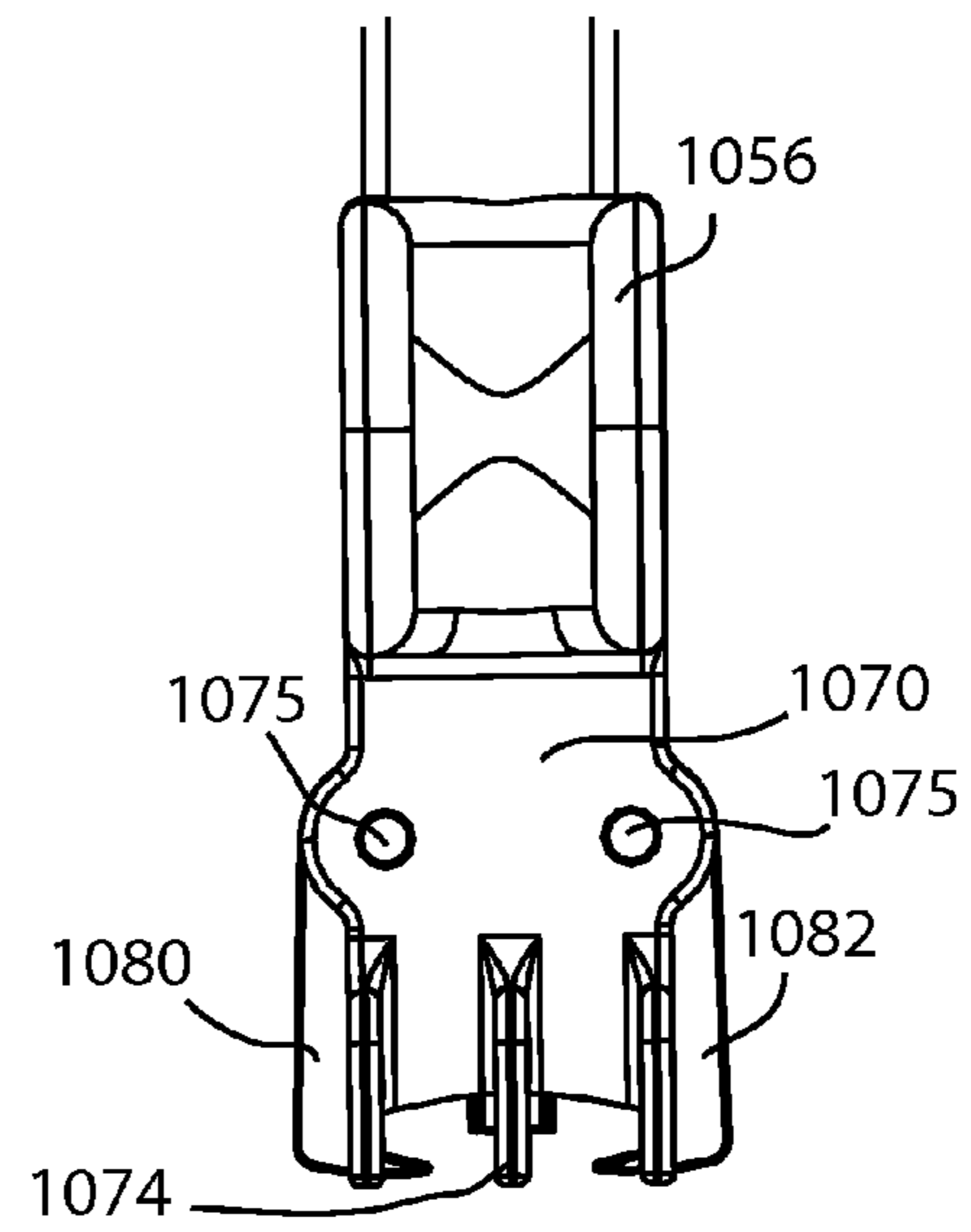

Fig. 38B

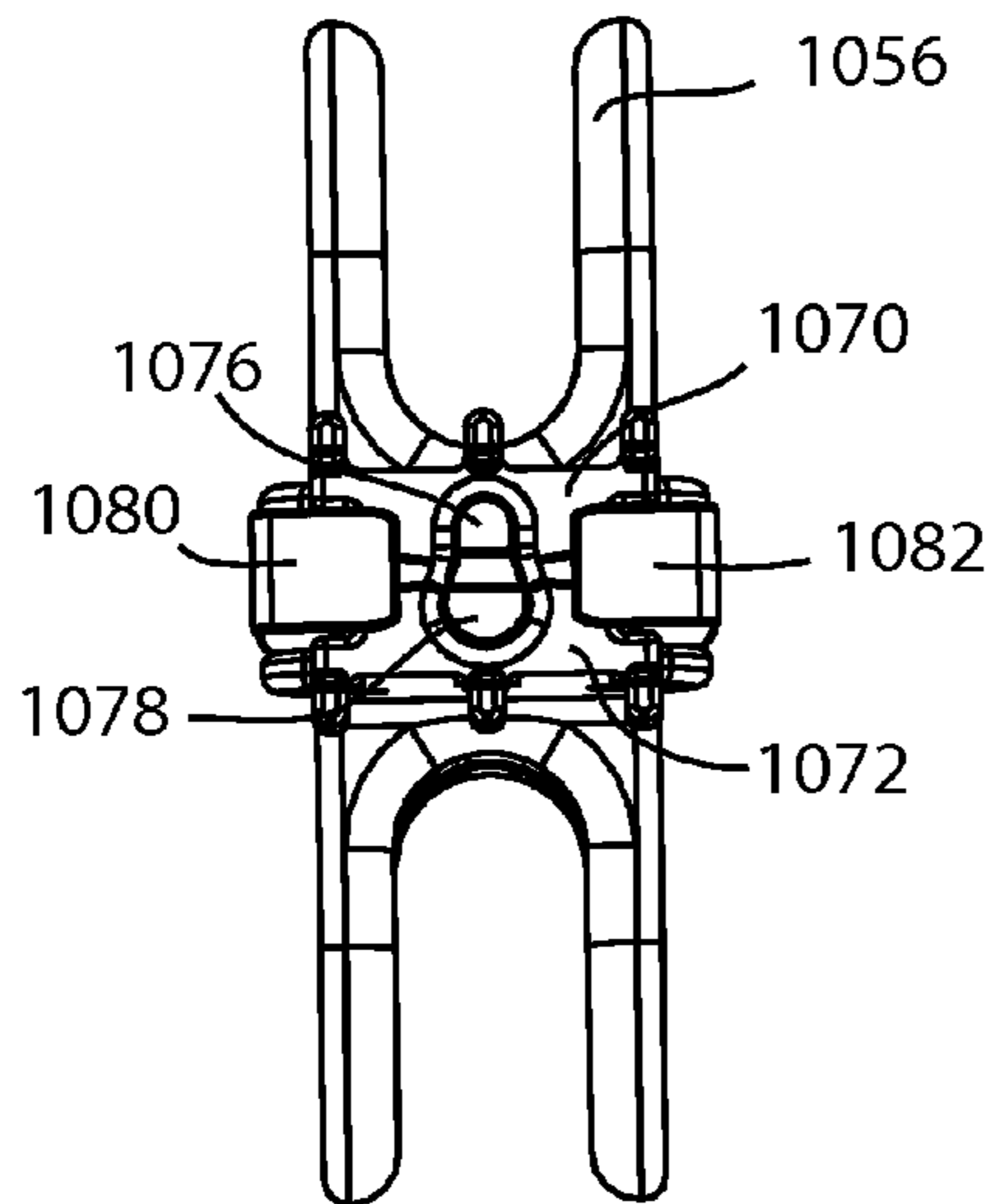

Fig. 38C

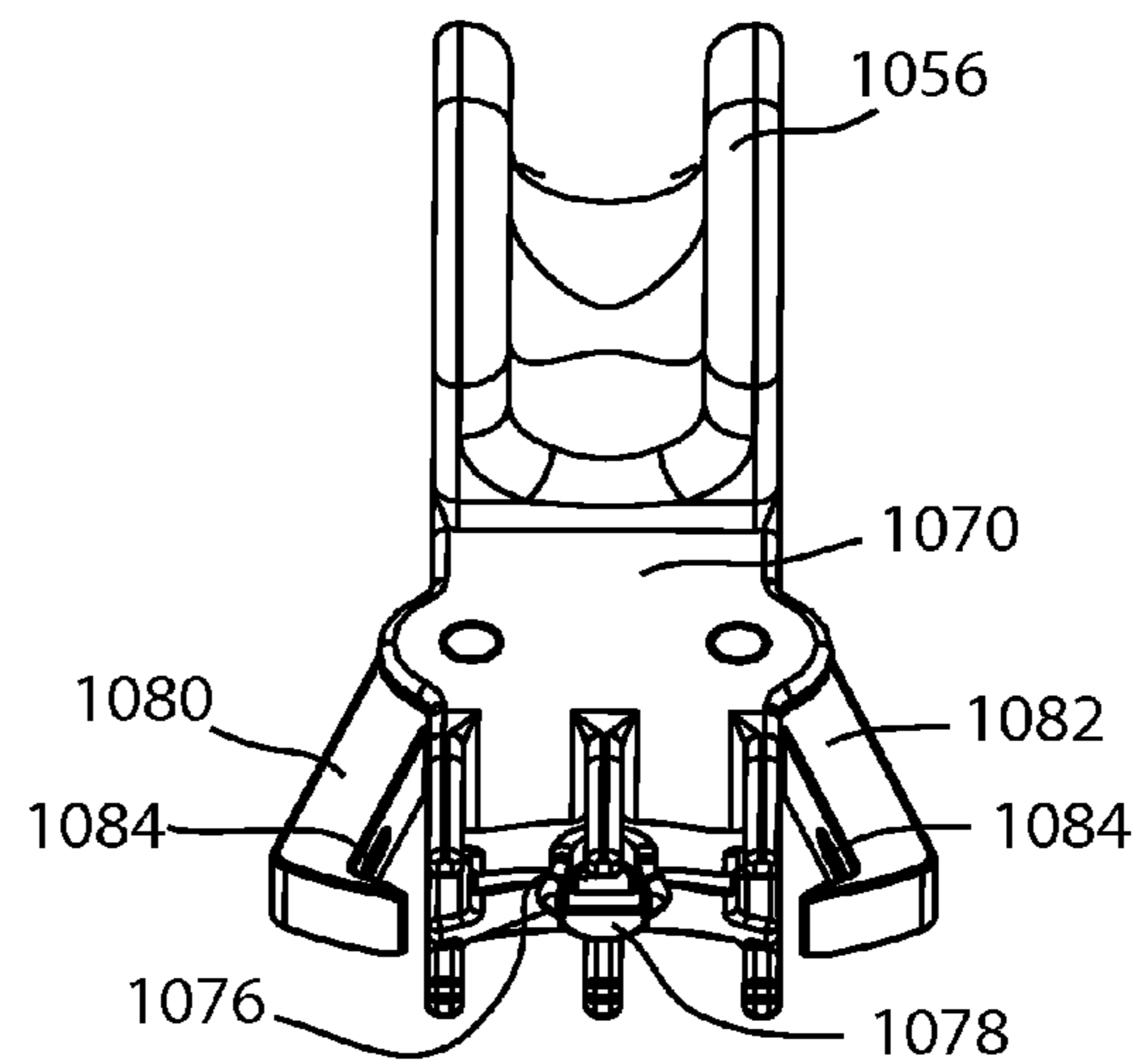

Fig. 38D

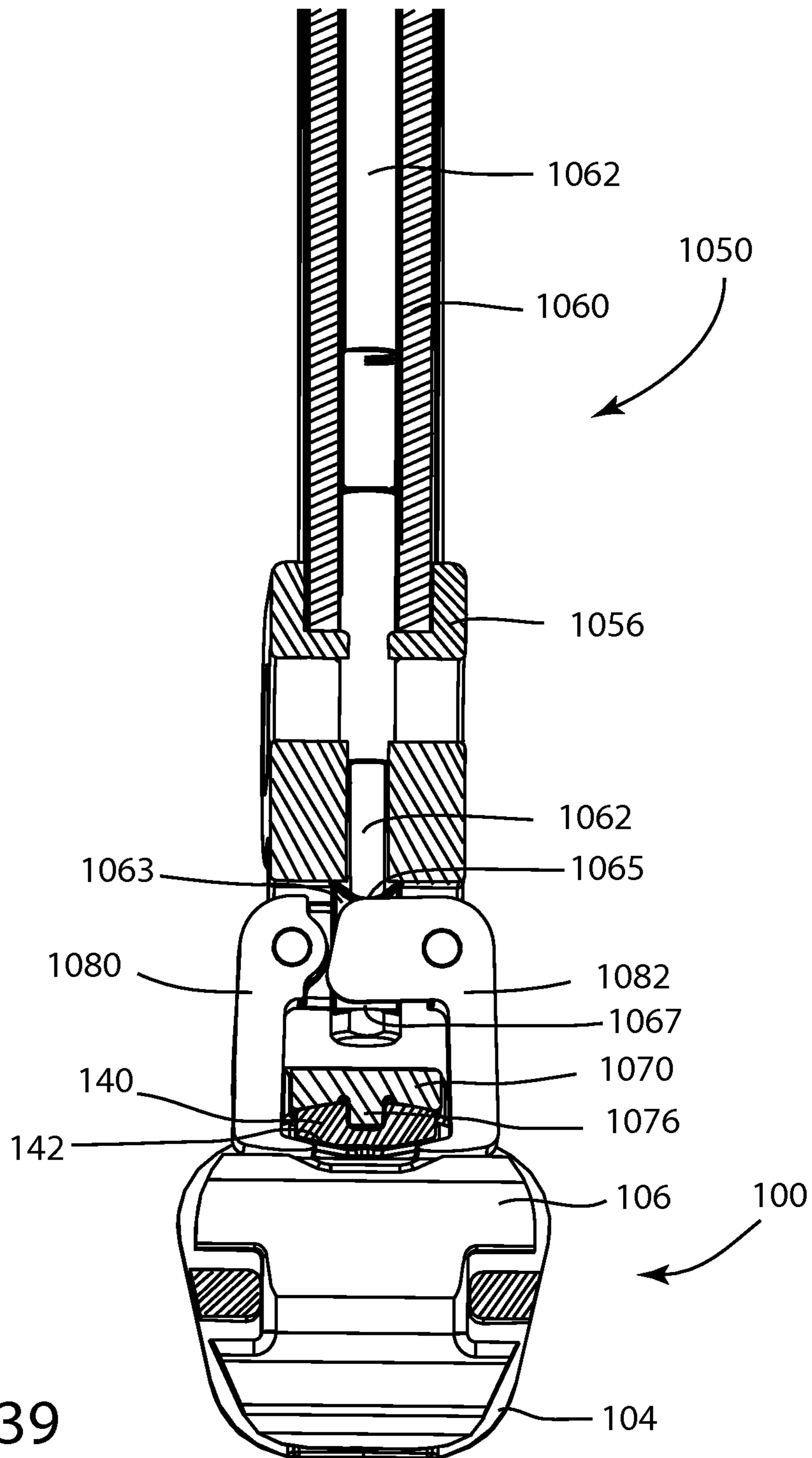

Fig. 39

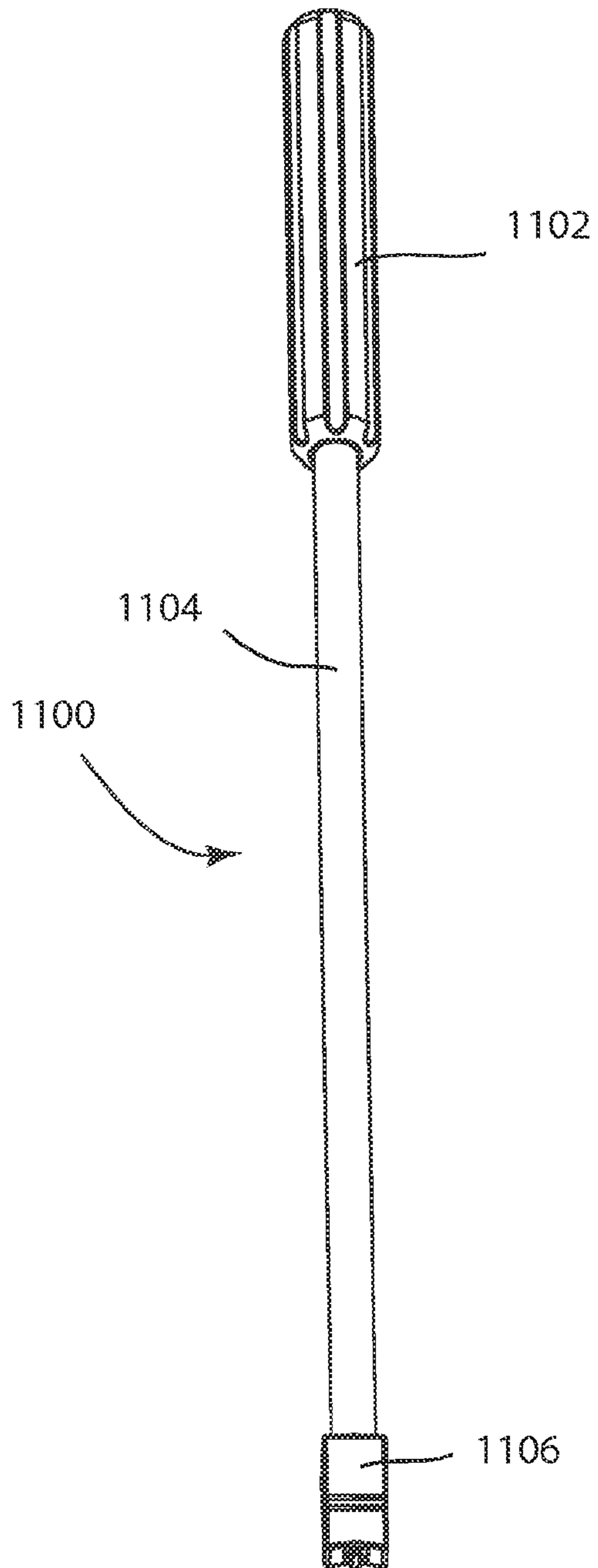

Fig. 40A

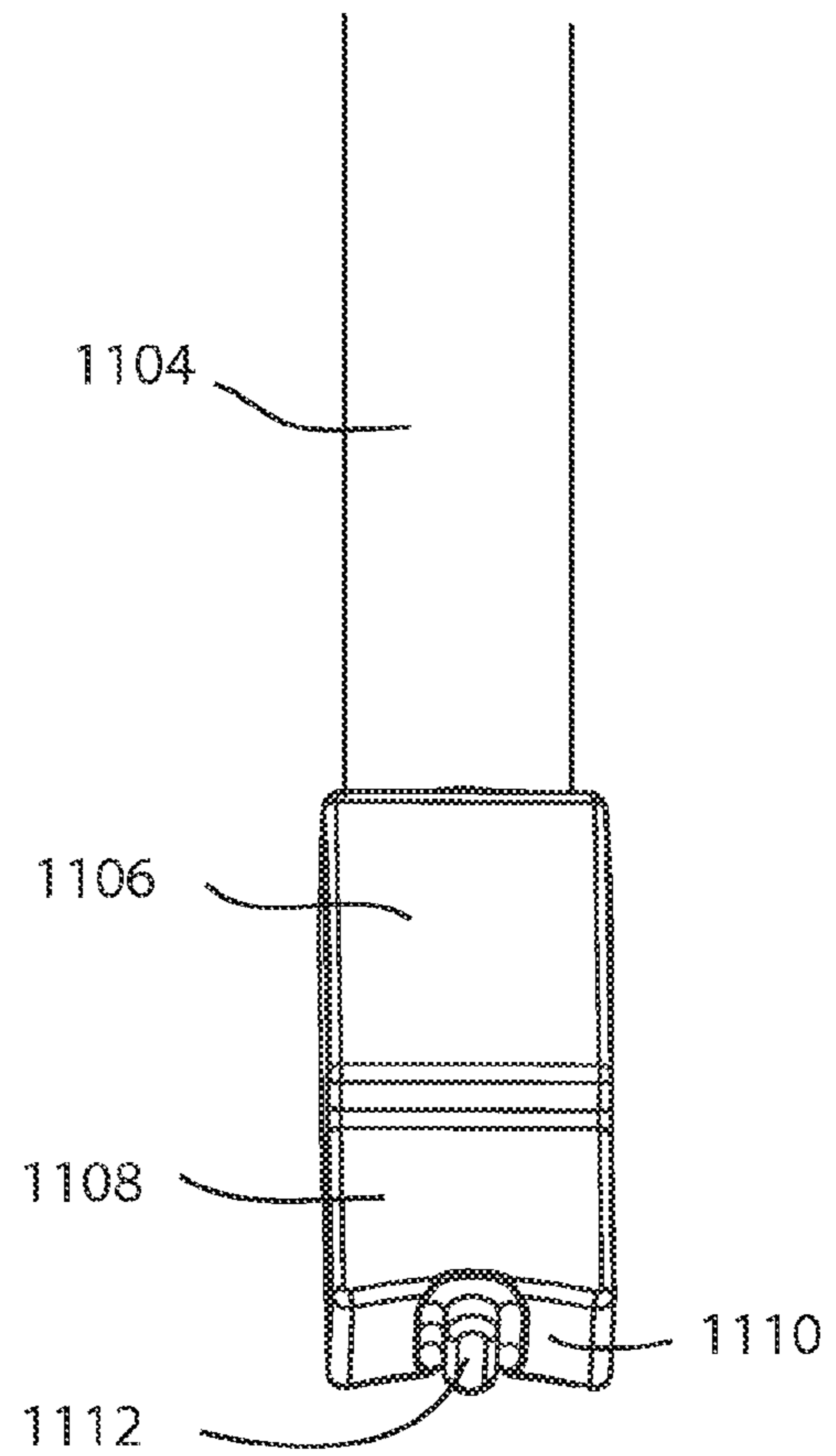

Fig. 40B

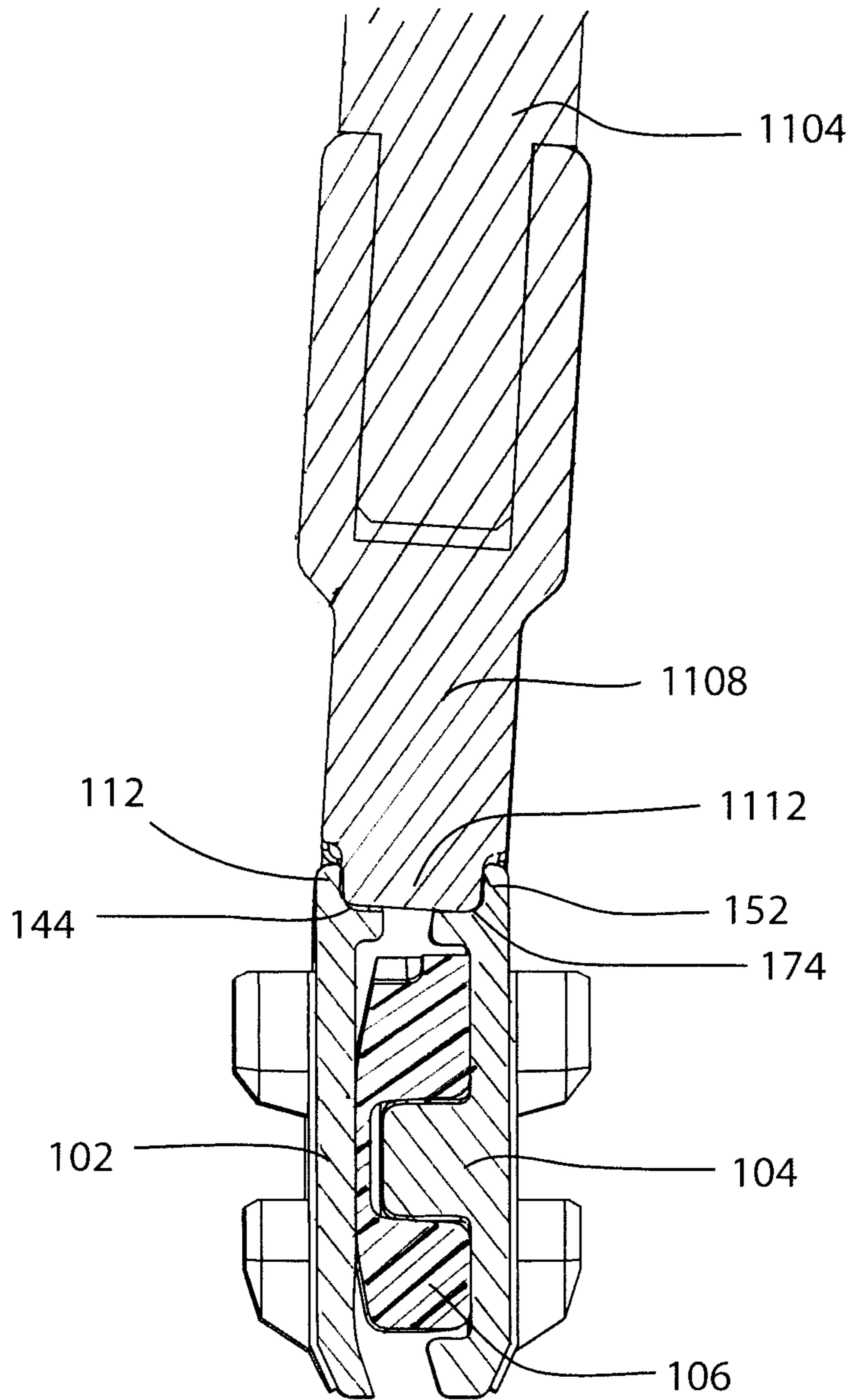

Fig. 41

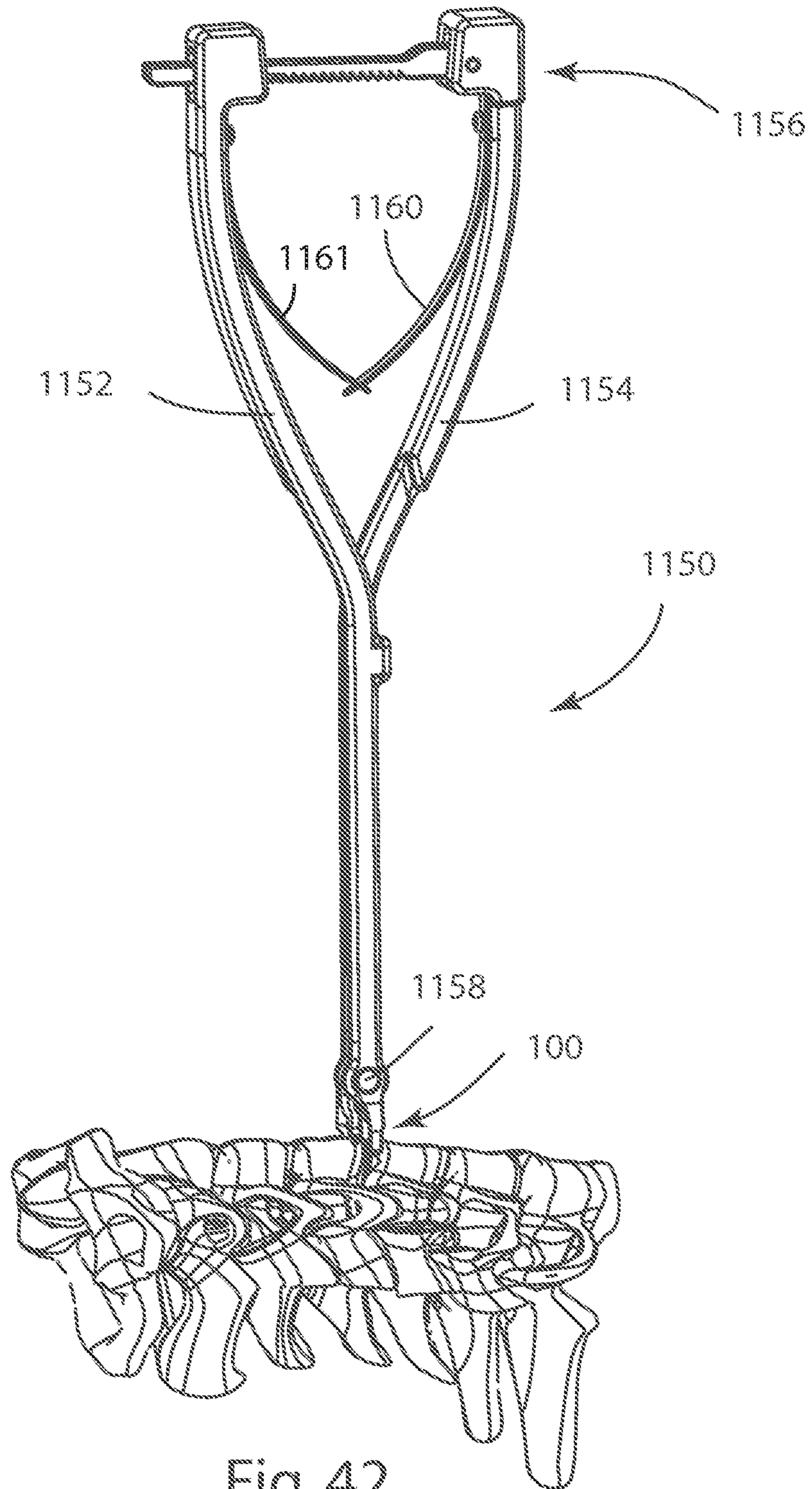

Fig. 42

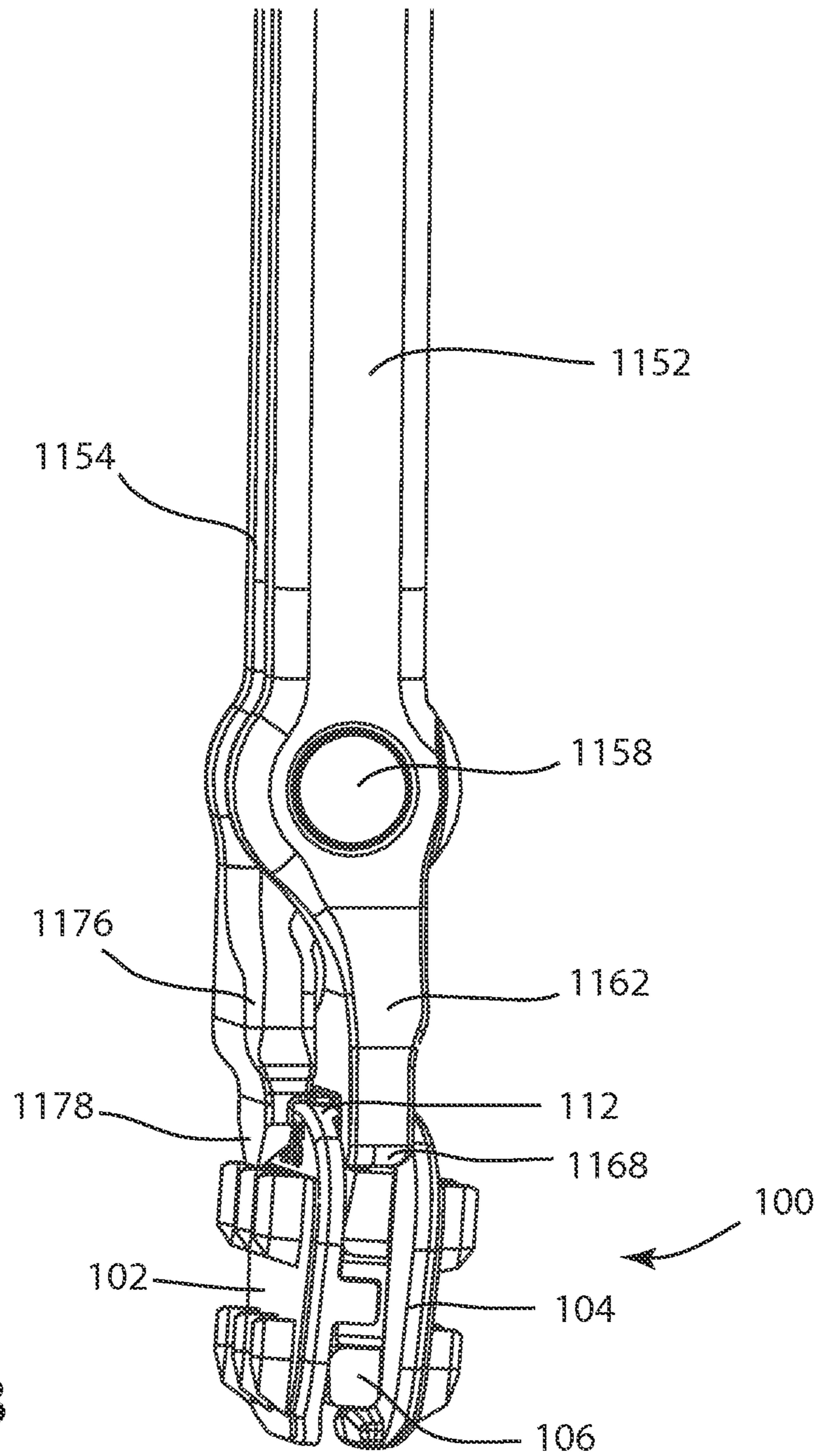

Fig. 43

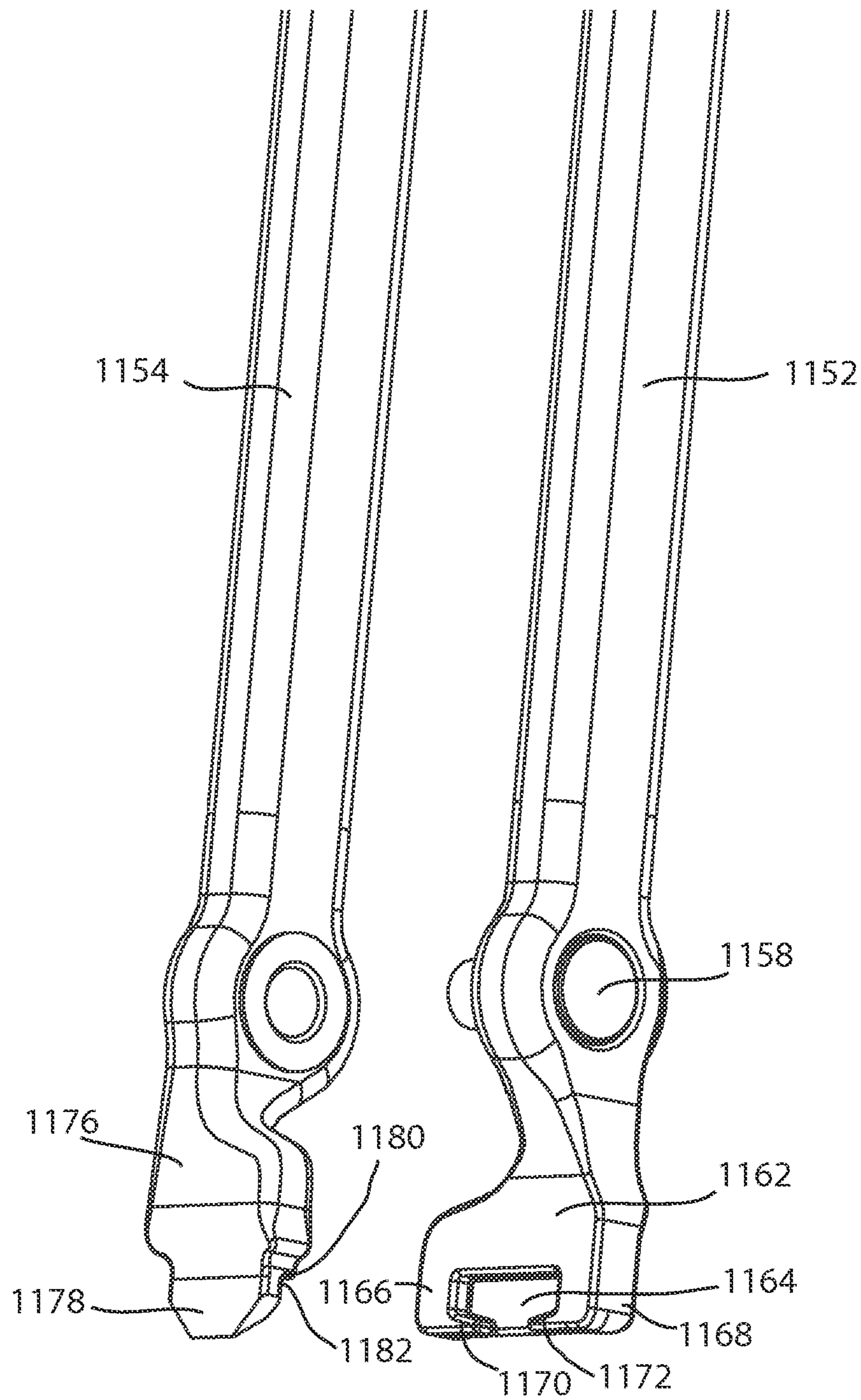

Fig. 44

## SYSTEMS AND METHODS FOR VERTEBRAL DISC REPLACEMENT

### CROSS-REFERENCE TO RELATED APPLICATIONS

This application is a continuation-in-part of:  
 pending prior U.S. patent application Ser. No. 12/258,961 filed Oct. 27, 2008 and entitled SYSTEMS AND METHODS FOR VERTEBRAL DISC REPLACEMENT, which is a continuation-in-part-of:

pending prior U.S. patent application Ser. No. 12/041,910 filed Mar. 4, 2008 and entitled JOINT PROSTHESES, which is a continuation-in-part-of:

pending prior U.S. patent application Ser. No. 11/559,215, filed Nov. 13, 2006 and entitled ARTIFICIAL SPINAL DISC, which is a continuation-in-part of:

pending prior U.S. patent application Ser. No. 11/534,014, filed Sep. 21, 2006 and entitled ARTIFICIAL SPINAL DISC, which is a continuation-in-part of:

pending prior U.S. patent application Ser. No. 10/590,139 filed Feb. 11, 2008 and entitled ARTIFICIAL SPINAL DISC filed as a U.S. national stage filing of:

PCT Application No. PCT/US05/023134, filed Jun. 30, 2005 and entitled ARTIFICIAL SPINAL DISC, which claims the benefit of:

prior U.S. Provisional Patent Application Ser. No. 60/658,161, filed Mar. 4, 2005 and entitled ARTIFICIAL SPINAL DISC, and

prior U.S. Provisional Patent Application Ser. No. 60/584,240, filed Jun. 30, 2004 and entitled ARTIFICIAL DISK FOR DEFORMITY CORRECTION.

U.S. patent application Ser. No. 12/258,961 filed Oct. 27, 2008 and entitled SYSTEMS AND METHODS FOR VERTEBRAL DISC REPLACEMENT claims the benefit of:

Provisional U.S. Patent Application Ser. No. 60/982,627, filed Oct. 25, 2007 and entitled ALTERNATE ARTICULATION SURFACE ARTIFICIAL CERVICAL DISC,

Provisional U.S. Patent Application Ser. No. 60/983,500, filed Oct. 29, 2007 and entitled ALTERNATE ARTICULATION SURFACE ARTIFICIAL CERVICAL DISC,

Provisional U.S. Patent Application Ser. No. 61/023,019, filed Jan. 23, 2008 and entitled VERTEBRAL DISC REPLACEMENT INSTRUMENTS AND PROCEDURE,

Provisional U.S. Patent Application Ser. No. 61/041,086, filed Mar. 31, 2008 and entitled VERTEBRAL DISC REPLACEMENT INSTRUMENTS AND PROCEDURE,

Provisional U.S. Patent Application Ser. No. 61/050,531, filed May 5, 2008 and entitled ARTIFICIAL DISC INSTRUMENTS AND METHODS, and

Provisional U.S. Patent Application Ser. No. 61/074,498, filed Jun. 20, 2008 and entitled COMPLIANT PROSTHESIS FOR BALANCE CONTROL ARTHROPLASTY.

This application is also a continuation-in-part of:  
 pending prior U.S. patent application Ser. No. 12/258,977 filed Oct. 27, 2008 and entitled SYSTEMS AND METHODS FOR VERTEBRAL DISC REPLACEMENT.

The above-identified documents are hereby incorporated herein by reference.

### TECHNICAL FIELD

The present invention relates to orthopedic medicine, and more specifically to methods and devices for the treatment of disc disease and spinal deformities with artificial disc replacement.

## BACKGROUND OF THE INVENTION

Spinal arthroplasty is an emerging field that offers the promise of restoring and/or maintaining normal spinal motion. The goal of spinal arthroplasty is to reduce or eliminate adjacent segment disease (ASD) by maintaining the normal spinal biomechanics at the operative level. To accomplish this, an artificial cervical prosthesis must duplicate as closely as possible the natural spinal biomechanics, including maintaining the axial height of the disc as well as applying angular adjustment throughout the full range of motion of the natural spine.

The spine plays an integral role in neural protection, load bearing and motion. The vertebral column provides a strong, yet mobile central axis for the skeleton and is composed of twenty-four vertebral bodies with seventy-five stable articulations. The intervertebral disc is a fundamental component of the spinal motion segment, providing cushioning and flexibility. Adjacent vertebrae are linked together by three articulations: a) the vertebral bodies and disc, which transmit compressive and shear loads and provide flexibility, and b) by two facet joints, which protect the disc from translational shear stress and limit rotation. This "triple joint complex" allows for flexion, extension, lateral bending and rotation of the spine.

The intervertebral disc is composed of an inner gel-like matrix called the nucleus pulposus and an outer surrounding fibrous band called the annulus fibrosus. When compressive loads are placed on the spine, increased pressure in the nucleus pulposus is transmitted to the annulus, which bulges outwards. The degenerative cascade of the intervertebral disc initially involves desiccation of the nucleus pulposus. With decreased elasticity and dampening from the nucleus, increased loads are transmitted to the annulus and facets. The increased stress on the annulus can lead to fissures and radial tears in its collagen fibers. With further degeneration, this can lead to circumferential bulging of the disc, contained and uncontained disc herniations, and complete desiccation of the disc. This degenerative cascade can result in axial pain, by stimulating pain fibers in the annulus, or compression of spinal nerve roots and/or the spinal cord. This can manifest itself in motor weakness, pain and/or numbness in the arms or legs or both.

The structure and function of the discs may be altered by a variety of factors including repeated stress, trauma, infection, neoplasm, deformity, segmental instability and inflammatory conditions. Degeneration of the intervertebral disc is the most common etiology of clinical symptoms referable to the spine. Degeneration of the spine is a universal concomitant of human aging. In the cervical spine, neck and arm pain caused by nerve root compression has been estimated to affect 51% of the adult population. Spondylosis of the spine and aging are intimately related, with spondylosis increasing in both prevalence and severity with age. Fortunately, the majority of patients will improve without surgery. In approximately 10-15% of cases, spondylosis is associated with persistent nerve root and spinal cord compression and/or spinal pain, with a small percentage ultimately requiring surgery.

The most common type of surgery used in the United States for the treatment of degenerative disorders of the spine (spondylosis) is spinal fusion. In an interbody fusion, the diseased disc is removed and either a wedge of bone from the patient's hip, allograft or a metallic spacer is placed between the vertebrae where the disc was removed. This immobilizes the functional spinal unit. While this surgery has been successful in eliminating motion, there are disadvantages associated with it. By converting a mobile, functional spinal unit



into a fixed, nonfunctional one, fusion results in increased strain patterns at levels adjacent to the fused segment. When a segment of the spine is fused, there is elimination of motion at the level of surgery. Therefore, the stresses that would normally be absorbed by the disc at the site of surgery are now transferred to adjacent segments. This can cause adjacent segment disease (ASD) to one or several spinal units adjacent to the affected level. ASD can be defined as a clinical syndrome of symptomatic degenerative changes occurring adjacent to a previously fused motion segment. Retrospective studies have estimated that ASD can occur in the cervical spine at a rate as high as 2.9% per year with a projected survivorship rate of 26% at 10 years (Hilibrand A S, Carlson G D, Palumbo M, Jones P K, Bohlman H H: Radiculopathy and myelopathy at segments adjacent to the site of a previous anterior cervical arthrodesis. *J Bone Joint Surg (Am)* 81:519-528, 1999).

In the cervical spine, thousands of North Americans undergo surgery for cervical spondylosis each year. The majority of these procedures involve an anterior discectomy with decompression of the spinal cord and/or nerve root. The primary indication for surgery in the management of cervical spondylosis is radiculopathy, myelopathy and/or neck pain. Following the discectomy, an anterior interbody fusion is commonly performed. Autologous bone harvested from the iliac crest or cadaveric bone is most commonly used to fill the space created by the removal of the disc. A number of other solutions have been suggested, including metallic devices such as fusion cages or other types of spacers, xenografts such as bovine bone, and biological strategies such as the use of growth factors. The graft for the interbody fusion can be shaped to correct underlying deformity of the cervical spine. By contouring the graft one can restore lordosis to a straight or kyphotic spine.

A more recent alternative to spinal fusion is replacement of the damaged disc with a motion preservation device, which includes either a nucleus or total disc replacement (TDR). The rationale for the development of the artificial disc is to prevent adjacent segment disease. Artificial disc devices can be broadly divided into two categories, those that replace the nucleus only, leaving the annulus and vertebral body end plates intact and those that involve replacement of the disc and addition of prosthetic end plates. Both strategies are directed at restoration of intervertebral disc function. Prosthetic nuclei are described, for example, in U.S. Pat. Nos. 5,047,055 and 5,192,326. United States Patent application US2002/0183848 also discloses a prosthetic spinal disc nucleus that has a hydrogel core surrounded by a constraining jacket.

There are several different types of prosthetic devices for use in the cervical or lumbar segments of the spine designed for TDR. For example, the Prodisc™ and the Charite™ disc are composites of cobalt chromium end plates with a polyethylene core. The Prodisc™ is described in U.S. Pat. No. 5,314,477 and the Charite™ disc is described in U.S. Pat. Nos. 5,401,269 and 5,556,431. The Prestige™ disc is another type of artificial disc that comprises a metal on metal design with a ball and trough articulation. Another type of artificial disc that is gaining popularity in the cervical spine is the Bryan® disc, described in several United States Patent applications including 2004/0098131; 2004/00544411; and 2002/0128715. The Bryan® disc is a composite artificial disc with a low friction, wear resistant, elastic nucleus that articulates with two circular metal plates.

Presently, there are at least four artificial cervical disc replacement systems undergoing clinical trials worldwide. These include unconstrained devices, such as the PCM cer-

vical disc. These unconstrained devices do not have mechanical stops to limit their range of motion. The Bryan® Cervical disc, the Prodisc™ C and the Prestige™ LP cervical disc systems limit range of motion to varying degrees. These systems can be considered semi-constrained, in that there are mechanical stops outside the normal range of motion.

Artificial spinal discs have been implanted for the management of degenerative disc disease producing radiculopathy, myelopathy and/or axial spinal pain. More recently, artificial discs have been adopted for the treatment of trauma. The aim of TDR is to reproduce the biomechanics of the natural disc. Early clinical and biomechanical studies with single and multi-level disc replacement have reported favorable clinical outcomes and preserved range of motion at the level of surgery. Preservation of range of motion, however, while an important feature of an artificial disc, is only a single measure of spinal biomechanics. The effect of the disc on angulation at the operative level, the average disc space height, and overall spinal alignment (sagittal and coronal balance) also needs to be considered.

While the introduction of artificial discs has led to many successful surgeries, there are still problems associated with the current discs. For example, all of the current artificial cervical discs have a fixed height across the entire disc. The artificial discs presently available can have issues with focal kyphosis or kyphosis at adjacent segments of the spine after the patient post-operatively reassumes an upright position, supporting the weight of the head and body. For instance, with the Bryan® disc, the end plates are allowed to move freely about all axes of rotation, allowing the end plate to assume a position resulting from the forces exerted on the implant by the head and neck. At times, this position may be significantly different from the positioning of the disc intra-operatively. Several published studies with the Bryan® cervical disc replacement system have reported a tendency for the end plates of the prosthesis and the alignment of the cervical spine to develop kyphosis following surgery. [Pickett G E, Mitsis D K, Sekhon L H et al. Effects of a cervical disc prosthesis on segmental and cervical spine alignment. *Neurosurg Focus* 2004; 17(E5):30-35; Johnson J P, Lauryssen C, Cambron H O, et al. Sagittal alignment and the Bryan® cervical disc. *Neurosurg Focus* 2004; 17(E14):1-4; Sekhon L H S. Cervical arthroplasty in the management of spondylotic myelopathy: 18 month results. *Neurosurg Focus* 2004; 17(E8):55-61.] This kyphotic angulation of the prosthesis has been attributed to the passive (unconstrained motion with a mobile nucleus and variable instantaneous axis of rotation) design of the implant. None of the current TDR systems addresses this major complication.

A significant number of patients with spinal disc disease have a loss of sagittal alignment of the spine as a result of the degenerative process. In addition, varying degrees of coronal imbalance can also occur. None of the available artificial disc replacement systems are designed to restore normal alignment to a spine that is straight, which have focal/global kyphosis or coronal deformity. Existing artificial disc replacement systems that are inserted into either a straight, kyphotic or angulated segment are likely to take on the angle and local biomechanics determined by the facets, ligaments and muscle forces. As such, patients with a pre-operative straight spine may develop post-operative kyphosis, and patients with a pre-operative kyphosis may have a worsening of the deformity post-operatively. Kyphosis of the spine has been implicated in segmental instability and the development of clinically significant degenerative disease. Several clinical studies have described that a change in the sagittal or coronal balance of the spine can result in clinically significant axial

spinal pain as well the initiation and/or the acceleration of ASD. [Kawakami M, Tamaki T, Yoshida M, et al. Axial symptoms and cervical alignment after anterior spinal fusion for patients with cervical myelopathy. *J Spinal Disord* 1999; 12:50-60; Harrison D D, Harrison D E, Janik T J, et al. Modeling of the sagittal cervical spine as a method to discriminate hypolordosis: results of elliptical and circular modeling in 72 asymptomatic subjects, 52 acute neck pain subjects, and 70 chronic neck pain subjects. *Spine* 2004; 29:2485-2492; Katsuura A, Hukuda S, Saruhashi Y, et al. Kyphotic malalignment after anterior cervical fusion is one of the factors promoting the degenerative process in adjacent intervertebral levels. *Eur Spine J* 2001; 10:320-324; Ferch R D, Shad A, Cadoux-Hudson T A, Teddy P J. Anterior correction of cervical kyphotic deformity: effects on myelopathy, neck pain, and sagittal alignment. *J Neurosurg* 2004; 100: S13-S19; Katsuura A, Hukuda S, Imanaka T, Miyamoto K, Kanemoto M. Anterior cervical plate used in degenerative disease can maintain cervical lordosis. *J Spinal Disord* 1996; 9:470-476.]

Attempting to provide a deformity correction by simply altering the end plate or the nucleus of an artificial disc, while still maintaining free movement about all axes of rotation, may not be sustainable as the forces exerted by the head and body on the artificial disc could counteract the desired correction. To provide a sustainable correction, some limitation on the axes of rotation is required. From a design perspective, the goal is to design an artificial disc that is able to correct deformity (coronal and sagittal), has mechanical stops outside the normal range of motion (semi-constrained), and preferably has variable instantaneous axis of rotation (IAR).

The limits on the axes of rotation can fall into two categories. One is to provide correction using a permanent rotation or translation of an axis to support the correction. This is accomplished using the geometries of the core and end plates themselves and is referred to the Geometric Constraint category. The second is to keep free range of motion about all axes but provide the correction using a material support. This type of design provides the correction by the imposition of a deformable material in the plane of correction for normal rotation in that plane. This is the Material Constraint category of designs.

Degenerative disc disease is a major source of morbidity in our society. It can lead to serious economic and emotional problems for those afflicted. Thus, there is a need for an artificial disc that can alleviate both symptoms and correct deformity (sagittal or coronal or both) of the spine.

#### BRIEF DESCRIPTION OF THE DRAWINGS

The novel features which are believed to be characteristic of the invention, both as to its organization and method of operation, together with further objects and advantages will be better understood from the following description when considered in connection with the accompanying figures. It is to be expressly understood, however, that each of the figures is provided for the purpose of illustration and description only and is not intended as a definition of the limits of the present invention. These and other features of the invention will become more apparent from the following description in which reference is made to the appended drawings wherein:

FIG. 1 illustrates an anterior view of two cervical vertebrae with an artificial disc prosthesis implanted between the vertebrae, the artificial disc prosthesis comprising a superior end plate, a nucleus which provides 6° of lordotic correction, and an inferior end plate;

FIG. 2 illustrates an exploded top perspective view of the superior end plate, nucleus, and inferior end plate of FIG. 1;

FIG. 3 illustrates an exploded bottom perspective view of the superior end plate, nucleus, and inferior end plate of FIG. 1;

FIG. 4A illustrates a top perspective view of the superior end plate of FIG. 1, and FIG. 4B illustrates a lateral view of the superior end plate of FIG. 1;

FIG. 5A illustrates a top view of the nucleus of FIG. 1, and FIG. 5B illustrates a bottom view of the nucleus of FIG. 1;

FIG. 6 illustrates a lateral cross-sectional view of the nucleus of FIG. 1;

FIG. 7A illustrates a posterior cross-sectional view of the nucleus of FIG. 1, and

FIG. 7B illustrates a posterior cross-sectional view of the nucleus of FIG. 1;

FIG. 8 illustrates a lateral view of the artificial disc prosthesis of FIG. 1 in a preferred orientation;

FIG. 9A illustrates a lateral view of an artificial disc nucleus that provides 0° of lordotic correction, FIG. 9B illustrates a lateral view of an artificial disc nucleus that provides 3° of lordotic correction, and FIG. 9C illustrates a lateral view of an artificial disc nucleus that provides 6° of lordotic correction;

FIG. 10A illustrates a sagittal cross-sectional view of the artificial disc prosthesis of FIG. 1 in a preferred orientation in the flexion-extension degree of freedom, and FIG. 10B illustrates a sagittal cross-sectional view of the artificial disc prosthesis of FIG. 1 in extension;

FIG. 11A illustrates a posterior cross-sectional view of the artificial disc prosthesis of FIG. 1 in a preferred orientation in the lateral bending degree of freedom, and

FIG. 11B illustrates a posterior cross-sectional view of the artificial disc prosthesis of FIG. 1 in lateral bending;

FIG. 12A illustrates a lateral view of the artificial disc prosthesis of FIG. 1 in flexion and lateral bending, and FIG. 12B illustrates an anterior view of the artificial disc prosthesis of FIG. 1 in flexion and lateral bending;

FIG. 13A illustrates a top view of the nucleus and inferior end plate of FIG. 1 in a neutral orientation with respect to rotation about a cephalad-caudal axis, and FIG. 13B illustrates the a top view of the nucleus and inferior end plate of FIG. 1 in an axially rotated orientation;

FIG. 14 illustrates an anterior perspective view of an alternative embodiment of an artificial disc prosthesis comprising a superior end plate, a nucleus, and an inferior end plate;

FIG. 15 illustrates an exploded bottom perspective view of the superior end plate, nucleus, and inferior end plate of FIG. 14;

FIG. 16 illustrates an exploded top perspective view of the superior end plate, nucleus, and inferior end plate of FIG. 14;

FIG. 17A illustrates a sagittal cross-sectional view of the artificial disc prosthesis of FIG. 14 in a neutral low-energy orientation with respect to the flexion-extension degree of freedom, FIG. 17B illustrates a sagittal cross-sectional view of the artificial disc prosthesis of FIG. 14 in flexion, and FIG. 17C illustrates a sagittal cross-sectional view of the artificial disc prosthesis of FIG. 14 in extension;

FIG. 18 illustrates an anterior perspective view of an alternative artificial disc prosthesis comprising a superior end plate, a nucleus, a retention element, and an inferior end plate;

FIG. 19 illustrates an exploded top perspective view of the superior end plate, nucleus, retention element, and inferior end plate of FIG. 18;

FIG. 20 illustrates an exploded bottom perspective view of the superior end plate, nucleus, retention element, and inferior end plate of FIG. 18;

FIG. 21 illustrates a portion of a spine with a partial discectomy between two cervical vertebrae;

FIG. 22 illustrates a guide tool aligned with the midline of the portion of the spine of FIG. 21;

FIG. 23A illustrates a perspective view of the guide tool of FIG. 22, FIG. 23B illustrates a lateral view of a head of the guide tool of FIG. 22, and FIG. 23C illustrates a perspective lateral view of the head;

FIG. 24 illustrates an awl inserted through the guide tool of FIG. 22;

FIG. 25 illustrates a perspective view of the awl of FIG. 24;

FIG. 26 illustrates a cross-sectional sagittal view of the guide tool and spinal portion of FIG. 22, with a driver tool driving a pin into a vertebral body;

FIG. 27 illustrates the spinal portion of FIG. 21, with two pins driven into adjacent vertebral bodies;

FIG. 28 illustrates an adjustable retainer secured to the pins of FIG. 27;

FIG. 29A illustrates a rack and pinion system of the adjustable retainer of FIG. 28, with a pawl in a neutral position, FIG. 29B illustrates the rack and pinion system with the pawl in a position to allow only compression, FIG. 29C illustrates the rack and pinion system with the pawl in a position to allow only distraction;

FIG. 30 illustrates the adjustable retainer of FIG. 28 and a separate distractor tool;

FIG. 31 illustrates a rasp tool which may be used with the adjustable retainer of FIG. 28;

FIG. 32 illustrates the adjustable retainer of FIG. 28 guiding a planer tool;

FIG. 33 illustrates the adjustable retainer of FIG. 28 and a feeler tool;

FIG. 34 illustrates a trial;

FIG. 35 illustrates an exploded view of the trial of FIG. 34;

FIG. 36 illustrates the trial of FIG. 34 guided by the adjustable retainer of FIG. 28;

FIG. 37 illustrates an implant inserter gripping the implant of FIG. 1;

FIG. 38A illustrates a lateral view of a distal end of the implant inserter of FIG. 37;

FIG. 38B illustrates a top view of the distal end of the implant inserter, FIG. 38C illustrates an end view of the distal end of the implant inserter, and FIG. 38D illustrates a perspective view of the distal end of the implant inserter in an open configuration;

FIG. 39 illustrates a top cross-sectional view of the distal end of the implant inserter and implant of FIG. 37;

FIG. 40A illustrates a tamp, and FIG. 40B illustrates an enlarged view of the distal end of the tamp;

FIG. 41 is a cross-sectional view of the tamp of FIG. 40 fitted to the implant of FIG. 1;

FIG. 42 illustrates a remover tool gripping the implant of FIG. 1;

FIG. 43 is an enlarged view of a distal end of the remover tool, and implant of FIG. 42; and

FIG. 44 is an exploded view of the distal end of the remover tool of FIG. 42.

#### DETAILED DESCRIPTION OF THE PREFERRED EMBODIMENTS

The present invention relates to systems and methods for the treatment of disc disease and spinal deformities with an artificial disc replacement. Those of skill in the art will recognize that the following description is merely illustrative of the principles of the invention, which may be applied in various ways to provide many different alternative embodi-

ments. This description is made for the purpose of illustrating the general principles of this invention and is not meant to limit the inventive concepts in the appended claims.

In its proper, healthy alignment, the spine follows natural curves, which promote proper sagittal and coronal balance (flexibility) and allow for balanced load sharing between the vertebrae. These curves include the cervical, thoracic, lumbar and sacral regions of the spine. Naturally, in order to accommodate a curve, there must be some variation in the angle of articulation between the functional spinal units and the height of an intradiscal space. The cervical and lumbar regions are naturally lordotic, or curved convexly in the anterior direction. At different segments along the spine, there are typically different heights for the vertebral bodies and the intradiscal space. In addition, the intradiscal space and vertebral body height may be different for different people.

Each intradiscal space has anterior and posterior regions. An artificial disc in the cervical, thoracic and lumbar regions that maintains the same height from the anterior to the posterior may promote an abnormal alignment, resulting in additional stress at the anterior or posterior portions of an adjacent disc. It may also result in an uneven load distribution across the device and cause an excessive amount of relative motion, wear debris and early failure.

As used herein, the terms, nucleus and core are used interchangeably to refer to an artificial intervertebral device that replaces a damaged natural spinal disc. The artificial core may be provided alone or in combination with a superior end plate for attachment to an upper vertebra or an inferior end plate for attachment to a lower vertebra or both.

The terms "upper" and "lower" are used herein to refer to the vertebrae on either side of the disc to be replaced, or a surface on a part in the position shown in the referenced drawing. A "superior" plate is affixed to an upper vertebra and an "inferior" plate is affixed to a lower vertebra of a functional spinal unit.

The terms vertical and horizontal are used herein relative to a standing human being in the anatomical position. The term "anterior" refers to the region towards the front and the term "posterior" refers to the region towards the back. The term "sagittal" refers to regions on either side of the central midline axis of a standing human being. The term "sagittal plane" used herein refers to a vertical plane extending along the central midline axis of the vertebral bodies of the spine, dividing the body into left and right lateral regions. The term "coronal plane" refers to a vertical plane extending along the central midline axis of the vertebral bodies of the spine, dividing the body into anterior and posterior regions through the center of the vertebral bodies. The term "cephalad-caudal axis" refers to a vertical axis which extends along the central midline axis of the vertebral bodies of the spine.

The term "asymmetrical" is used herein to refer to an axis of maximum height that is not placed centrally or to a nucleus or total disc replacement (TDR) not having its maximum vertical axis placed centrally. In other words, the maximum height is not situated or pivoted at a center line of symmetry so that the TDR comprises regions that are not exactly the same in shape or size as other regions on the other side of a line of symmetry. The location of maximal load bearing is located in a non-central location. The term may analogously apply to joint prostheses in which an axis of maximum height is not located centrally on a substantially convex bearing surface, or the axis of maximum depth of a depression is not placed centrally on a substantially concave bearing surface.

The term "normal alignment" is used herein to refer to the natural positioning of functional components of a healthy joint, relative to one another and/or the surrounding tissues.

Normal alignment may refer to the static position of a joint at rest, wherein no stress or pressure is placed on the joint, and it may also refer to the dynamic position of a joint under natural mechanical stress such as during flexion or extension. Normal alignment may also be referred to as natural, healthy, or proper alignment. “Preferred” or “desired” alignment are used herein to refer to joint alignment that may be natural, or corrected, but places the joint components in a functional or desired position. The terms “preferred orientation” or “preferred relative orientation” used herein also refer to component alignment that may be natural, or corrected, in which the joint components are in a functional or desired position.

The phrase “preferred relative orientation” may refer to an orientation about a single axis, or about multiple axes. For example, an artificial disc implant may be designed to establish a preferred relative orientation about an axis extending medial-laterally to provide a preferred anterior-posterior angulation that mimics the appropriate lordosis or kyphosis of the joint motion segment. Alternatively, an artificial disc implant may be designed to establish a preferred relative orientation about an axis extending generally anterior-posteriorly to provide a preferred medial-lateral angulation that provides the desired degree of lateral bending. Such lateral bending may be zero degrees, reflecting the straightness of a healthy spine, or may be nonzero to the left or right to provide correction for various pathologies including scoliosis. As another alternative, an artificial disc implant may be designed to provide a preferred relative orientation about both of the medial-lateral and anterior-posterior axes to encourage proper lordosis or kyphosis while also encouraging the desired lateral bending. A preferred relative orientation may also be a low energy position in which the joint is naturally encouraged to remain, in contrast to a point of resistance such as a motion stop.

An “orientation feature” is a feature present on one or more joint components that help the components establish a preferred relative orientation. For example, opposing bearing surfaces on joint components may include flattened sections, which cooperate to urge the components toward attaining a preferred relative orientation. Matching curved surfaces which align better in a preferred relative orientation may also be orientation features. Other configurations of orientation features may be possible in addition to flat and curved surfaces.

It has been found that nucleus body designs with a completely rounded surface (not necessarily spherical) have issues with reliably maintaining correction when exposed to the variable forces of the head and neck. To address this issue, one or more segments or sections that is flat or which has a contour different from the adjacent surface, can be formed in the nucleus body. This section will be referred to as a flattened section, which is meant to refer to any contour that is not the same as the adjacent surface(s) of the nucleus. Such a flattened surface can be planar or it can have other shapes such as a slight convex or concave shape with a radius of curvature different from the adjacent surface. Such a flattened surface could also be in the shape of a compound curve or other complex shape. A flattened section may also refer to a rectilinear portion of a two dimensional shape. In the example of providing a lordotic correction, the flattened segment can be angled relative to the superior end plate of the inferior vertebral body with the height of the anterior part being greater than the height of the posterior part. The overall shape of the nucleus body is still asymmetric, but the flattened segment is incorporated to provide a reliable correction of the deformity. This flattened segment provides stabilization to resist the moments acting through the nucleus, i.e., if the flat is not of

adequate size, there may be a tendency for the correction to disappear in the presence of an anterior load or for a hyperlordotic over correction in the presence of a posterior load (during lordotic correction). An additional advantage of incorporating a flattened segment in the nucleus is to provide surface contact over that area during small motions about the resting, neutral position of the device, which may help reduce the stresses and potentially wear of the device.

This flattened surface can be angled relative to the superior end plate of the inferior vertebral body (or vice versa, or both), with the height of the anterior end being greater than the height of the posterior end when lordotic correction is sought. The overall shape of the core can still be asymmetric, but the flattened surface can be incorporated to provide a reliable correction of the deformity. Alternatively, the core may have flattened sections but be symmetric and the endplates may be asymmetric or angled to provide the lordotic correction.

The invention includes a novel artificial disc that provides the normal range of motion of the natural intervertebral disc, along with the ability to correct deformity of the spine. The proposed disc allows for semi-constrained range of motion of the functional spinal unit. It reproduces the kinematics of the pre-operative normal spine in all motions. Of particular, the proposed disc allows for independent & mobile centers of rotation in the flexion-extension and lateral-bending motions, which is unique to this device but an inherent characteristic of the natural spine. It possesses maximum durability and biocompatibility, and a means for integrating itself into the spine bony structure for long-term stability. Its insertion is safe, simple, and surgical time is not compromised compared with the current procedures. In contrast to the existing disc replacement systems, it will allow the surgeon to correct deformity while maintaining natural kinematics of the spine.

In at least one embodiment of the present invention, an artificial disc comprises a nucleus that is not geometrically symmetrical. The disc may have a maximum vertical axis that is not located at the geometric center of the disc. The maximum vertical axis may be located toward the front of the disc, the rear of the disc and/or on one side of the disc. The positioning of the maximum vertical height and load bearing capability is chosen depending on the type of deformity that needs to be corrected. The present invention also provides methods for the treatment of disc/vertebral body disease, lordosis, kyphosis and scoliosis using an asymmetric artificial disc.

One advantage of the present invention is that the “nucleus” or core may be interchanged and revised intra-operatively and post-operatively. Instruments can be used to gauge the need for and amount of correction and the appropriate implant can then be inserted. By introducing correction into the nucleus, the surgeon benefits from flexibility, ease of insertion and revisability that present systems do not provide.

Artificial discs of the present invention can be provided with various degrees of deformity correction. For this aspect of the invention, the surgeon can choose a disc having the appropriate correction for the patient. Thus, a method of treating a spinal deformity is provided. This method comprises preparing a spinal segment for implantation of an artificial disc, determining the desired angle of the intervertebral space, selecting an artificial nucleus having the desired dimensions, affixing a superior end plate to the upper vertebra, affixing an inferior end plate to the lower vertebra and inserting the selected nucleus between the superior and inferior end plates. Alternatively, and the assembled unit of end plate-nucleus-end plate may be inserted in unison. The configuration of the nucleus in this pre-assembled construct can be determined by the intra-operative measurement tools, or

## 11

with pre-operative calculations. Pre-operative planning techniques and instruments may also be able to determine the size and orientation of this device for insertion.

A major advantage of the present system is that the artificial disc can be more easily and rapidly inserted and the nucleus can be changed or revised in accordance with the magnitude of the deformity being corrected. This is especially useful in children and young adults where the alignment of the spine changes over time.

In at least one embodiment, an asymmetric nucleus adapted for lordotic correction of the cervical spine is provided. The surgeon can restore lordosis to the cervical spine while maintaining motion. The nucleus may be composed of a low friction elastomer such as polyurethane, polycarbonate-polyurethane, a polymer such as polyethylene (particularly ultra-high molecular weight polyethylene or UHMWPE), a suitable ceramic, metals, metal matrix composites such as titanium carbide, or metal alloys such as titanium or a titanium alloy, chrome-cobalt-molybdenum (CoCrMo), cobalt chrome, stainless steel, or other suitable materials. It has a generally trapezoidal geometric design, with varying degrees of lordosis incorporated into it by utilizing an axis of maximum height anterior to the geometric center of the nucleus. The anterior height of the nucleus varies, depending on the extent of lordotic correction needed. The nucleus may be available in various lordotic angles, e.g. 0, 3° and 6°, as well as differing heights (e.g., 4, 6 and 8 mm).

Before deciding on the final nucleus size, a set of instruments could be inserted to confirm the lordotic correction, but these may also be used as confirmation for other types of pre-surgical planning techniques and instrumentation. Alternatively, intra-operative instruments may be used as confirmation for other types of pre-surgical planning techniques and instrumentation.

In one embodiment, the implant consists of three pieces; a superior end plate, an inferior end plate, and the nucleus. The end plates will be made in differing sizes to accommodate differences in anatomy. These may be fabricated of titanium, titanium carbide, or a titanium alloy, cobalt-chrome-molybdenum (CoCrMo), cobalt chrome, stainless steel, metal matrix composites, or other materials suitable for spinal prosthetic inserts. They may also be mainly fabricated from one or more materials and utilize a separate coating surface or material layer for optimizing mechanical and wear performance. Coatings could be used for lubricity, low-friction, enhanced hardness, low surface energy, roughness, or other desirable characteristics for an articulating joint.

The end plates can have two distinct surfaces. The flat surface of each end plate, which contacts the vertebral body end plate, is capable of accommodating bony ingrowth and incorporates a suitable coating, such as porous titanium, a calcium phosphate, or includes other types of known surfaces that promote bony ingrowth for long-term stability. The end plates can also have one or more parasagittal keels or teeth that provide immediate fixation.

While the embodiment illustrates below include three piece prostheses with two end plates and a nucleus, it is appreciated that any nucleus disclosed herein could be integrated with one of the adjoining end plates to provide a two piece embodiment. At least one of the remaining articular surfaces may be augmented by re-shaping of the surface to compensate for the motion lost due to integration.

FIG. 1 illustrates an embodiment of an artificial disc replacement implanted in an intervertebral space between two adjacent vertebrae in a portion of a spine. Artificial disc prosthesis 100 comprises a superior end plate secured to a superior vertebral body 2, an inferior end plate 104 secured to

## 12

an inferior vertebral body 4, and a nucleus 106 positioned between the superior and inferior endplates. Securing an end plate to a vertebral body comprises coupling the end plate to the vertebral body so that it remains in place at least long enough for bony ingrowth to occur. The disc prosthesis 100 comprises a plurality of articulating surfaces which form articulating joints, permitting restoration of intervertebral motion including flexion/extension, anterior/posterior translation, lateral bending and axial rotation, between the end plates. The disc prosthesis 100 further comprises orientation features which may allow the joints to remain in a preferred orientation relative to one or more axes, which may be a neutral low energy position which the joint is naturally encouraged to maintain.

FIGS. 2 and 3 illustrate exploded perspective views of the disc replacement 100; FIG. 2 from a cephalad-lateral perspective and FIG. 3 from a caudal-lateral perspective. Various features of the end plates 102, 104 are visible in these views. Each end plate 102, 104, is generally trapezoidal in shape, although alternative shapes such as rectangular, circular, oval or kidney, among other, are contemplated for other embodiments of the invention. Superior end plate 102 comprises an end plate body 110 with an anterior end 112, posterior end 114, left lateral side 116, right lateral side 118, superior side 120 and inferior side 122. The superior side 120 has a bone engagement surface 124 which is essentially flat, enabling it to easily contact the surface of the natural vertebral end plate. Use of a flat bone engagement surface may eliminate extra surgical time needed to prepare the vertebrae to the appropriate shape to accommodate the end plate. However, it is appreciated that other embodiments of the invention may include end plates which do not have flat bone engagement surfaces, but shaped surface which may be generally concave or convex. The bone engagement surface can be porous and incorporate a suitable treatment, such as porous titanium, a calcium phosphate or other types of known treatments such as coatings, plasma sprays, and structural changes to the surface, that promote bony ingrowth or ongrowth for long-term stability. An anterior portion 126 of the end plate 102 may not incorporate the ingrowth treatment, to allow for easier instrument insertion and gripping. A posterior angled portion 128 of the body slopes caudally at an acute angle from the remainder of the body 120, allowing for ease of insertion of the prosthesis into the intervertebral space during implantation. A plurality of first teeth 130 and second teeth 131 may project outwardly from the bone engagement surface 124.

The inferior side 122 of the superior end plate 102 comprises an essentially planar articular surface 132. Two flanges, a left flange 134 and a right flange 135 protrude caudally from the articular surface, positioned centrally along the lateral sides 116, 118 of the end plate. The flanges 134, 135 are positioned to fit into gaps formed by notches formed in the nucleus 106. Other embodiments may include flanges positioned at the corners of the end plates, or at other locations along the lateral sides. A sloped surface 136 is formed on the inferior side of left flange 134, and a sloped surface 137 is formed on the inferior side of right flange 135. After implantation of the prosthesis and during lateral bending, the sloped surfaces 136 or 137 do not contact a superior surface of the inferior end plate, as an inferior surface the nucleus instead contacts the superior surface of the inferior end plate to provide a soft stop to the lateral bending motion. The heights of the flanges 134, 135 may vary, and the slope of the sloped surfaces 136, 137 may vary. An anterior-posterior dimension of the flanges 134, 135 may be less than an anterior-posterior dimension of the gaps in the nucleus 106, allowing constrained anterior-posterior translation of the end plate 102

relative to the nucleus. A soft stop may occur when a first component, such as a nucleus, comprising material such as UHMWPE contacts a second component, such as an end plate, comprising a harder material such as titanium or other metals, in a way as to prevent further motion of the first component along the same direction. Conversely, the moving first component may comprise the harder material, and the second component may comprise the relatively softer material.

An anterior retention member **140** is formed along the anterior side of the end plate **102**, protruding caudally toward the inferior end plate **104**. The anterior retention member **140** may assist in preventing displacement of the nucleus from between the end plates, as the member **140** is positioned anterior to the anterior edge of the nucleus **106**. An inner edge **142** of the member **140** is angled to permit limited rotation of the nucleus relative to the end plate **102** to accommodate device axial rotation. This inner edge **142** also serves as an axial rotation stop to limit the amount of axial rotation. The inner edge **142** is also dovetailed to engage gripping arms of a prosthesis insertion tool. A pocket **144** is formed into the anterior portion of the member **140** and serves as a receptacle for instrumentation during implantation, revision or removal of the prosthesis. After implantation of the prosthesis and during flexion of the spine, the anterior member **140** does not contact the inferior end plate **102**, as the nucleus contacts the inferior end plate, to provide a motion stop before the member **140** could contact the inferior end plate. Other embodiments of the invention may include multiple anterior members formed on the superior end plate, or no anterior members formed on the superior endplate.

Inferior end plate **104** comprises an end plate body **150** with an anterior end **152**, posterior end **154**, left lateral side **156**, right lateral side **158**, superior side **160** and inferior side **162**. An essentially planar superior articular surface **164** extends across the end plate body **150**. A posterior retention member **166** is formed at the posterior end **154**, protruding from the superior side **160**. The posterior retention member is bounded by an inner edge **168** which is angled to permit limited axial rotation of the nucleus **106** relative to the end plate **104**, and by a superior surface **169** which may be angled laterally and posteriorly to allow lateral bending during extension. An anterior retention member **170** with an angled inner edge **172** is located along the anterior end **152**, protruding from the superior side **160** toward the superior end plate **102**. A pocket **174** is formed in the retention member **170**, which may receive instrumentation during implantation, revision or removal of the prosthesis. A superior surface **176** of the retention member **170** may be angled laterally and anteriorly to permit lateral bending during flexion.

A pin, or post **180** protrudes from the superior side **160** in a cephalad direction toward the superior end plate **102**. The post **180** may be located in a geometric center of the inferior end plate **104**, or it may be displaced from the geometric center. The location of the post **180**, and a corresponding pocket in the nucleus, determines the cephalad-caudal axis about which the nucleus and the opposing end plate may rotate relative to the inferior end plate **102**. Generally cylindrical in shape to permit rotation about the cephalad-caudal axis, the post **180** comprises a circumferential wall **182** with a spherical shoulder **183**, which may articulate with a wall of the nucleus pocket. To prevent or limit rotation about a cephalad-caudal axis, the post could have a non-cylindrical shape such as a square or triangle, among others. The post **180** also cooperates with the nucleus pocket to permit lateral bending simultaneously with axial rotation.

The inferior side **162** of the inferior end plate **104** comprises a planar bone engagement surface **186**, on which one or a plurality of teeth **130**, **131** may be formed. An anterior portion **188** may be free of bone ingrowth or ongrowth treatments to allow for engagement with instrumentation. A posterior angled portion **190** of the body slopes cephaladly at an acute angle from the remainder of the bone engagement surface **186**, again allowing for ease of insertion of the prosthesis into the intervertebral space during implantation.

Referring to FIGS. **4A** and **4B**, a plurality of bone engagement features, comprising self-cutting first teeth **130** and second teeth **131**, may be formed on the bone engagement surfaces **124**, **186** of the superior and inferior end plates. Teeth **130**, **131** have sharply pointed leading edges, which cut into the vertebral bodies during insertion and may eliminate extra preparation steps such as pre-cutting or reaming grooves into the surfaces of the vertebral bodies. Each second tooth **131** may be positioned directly behind, or anterior to, a first tooth **130**. Each first tooth **130** has a narrowly angled cutting point **202**, and is positioned with the point oriented toward the posterior end **114** of the endplate **102**. As the end plate is inserted between the vertebral bodies, the sharp cutting point **202** on each first tooth **130** cuts a track into the surface of the vertebral body. As the end plate is slid further in, the second tooth **131** follows in the track cut by the first tooth **130**, and a wider cutting point **204** on the second tooth widens the track.

Each first tooth **130** has a pointed apex **206** positioned atop the tooth, supported by a pair of support walls **208** and an end wall **210**. The support walls **208** are angled toward one another from the bone engagement surface **124** or **186** to the apex **206**. This angulation advantageously permits a solid press-fit as the tooth penetrates the vertebral body, providing immediate anchorage. The angled walls **208** also allow some subsidence of the end plate **102** into the vertebral body after implantation, without the risk of loosening from the vertebral body. The end wall **210** may be vertical or near vertical, promoting retention in the vertebral body and prevention of unintended withdrawal from the vertebral body. In other embodiments of the invention, the walls **208** may not be angled but instead parallel to one another.

Each second tooth **131** comprises the wide cutting point **204**, two angled support walls **212** and an end wall **216** which support a pointed apex **214**. The second teeth **131** are similar in configuration to the first teeth **130**; however particular dimensions such as wall height and the angle and width of the cutting point may vary. For example, as shown in FIG. **4A**, second tooth **131** is laterally wider than first tooth **130**, while the cutting point **202** of first tooth **130** is narrower than the cutting point **204** of second tooth **131**. Looking at FIG. **4B**, the support walls **212** and apex **214** of the second tooth **131** are taller, providing a larger vertical dimension than the support walls **208** and apex **206** of the first tooth **130**. A posterior leading edge **218** of first tooth **130** is more gently sloped than a posterior leading edge **220** of second tooth **131**, which may aid in insertion. All first and second teeth **130**, **131** may incorporate the same bone ingrowth or ongrowth treatments as the bone engagement surfaces **124**, **186**.

Both end plates **102**, **104** are general laterally symmetrical; however in alternative embodiments one or both of the endplates could have a maximum vertical dimension located on one lateral side to provide a scoliotic correction. Similarly, one or both of the endplates could have an anteriorly located maximum vertical dimension to provide a lordotic correction, or a posteriorly located maximum vertical dimension to provide a kyphotic correction. It is appreciated that specific features of the end plates, including but not limited to bone engagement features, motion stops, instrument recesses, and

posts, may be swapped, inverted or reversed such that features found on the superior end plate may be instead located on the inferior end plate, and vice versa. Additionally, in alternative embodiments features found on end plates may instead be located on the nucleus, and vice versa.

FIGS. 5A, 5B, 6, 7A, and 7B illustrate various views of the disc nucleus 106. Like the end plates 102, 104, the nucleus has a generally rounded trapezoidal shape, although alternate embodiments may have other shapes. The nucleus 106 comprises a superior side 250, an inferior side 252, an anterior end 254, a posterior end 256, a left lateral side 258 and a right lateral side 260. The superior side 250 comprises a nuclear superior articular surface 262, which further comprises three planar portions: an anterior planar portion 264, a middle planar portion 266, and a posterior planar portion 268. A first curvate transition portion 270 lies between the anterior planar portion 264 and the middle planar portion 266, while a second curvate transition portion 272 lies between the middle planar portion 266 and posterior planar portion 268. The three planar portions are perpendicular to a sagittal plane of the vertebral bodies when the implant is properly implanted in an intervertebral space. The planar portions are not co-planar with respect to one another, although an alternative embodiment of the invention could include one or more co-planar planar portions. An angle a1, the angle between the anterior 264 and middle 266 planar portions, is acute and may be unequal to an angle a2, the angle between the middle 266 and posterior 268 planar portions. In other embodiments, angles a1 and a2 may be equal. The nucleus inferior side 252 comprises an inferior articular surface 280, which, like the superior articular surface, also comprises three planar surfaces separated by two curvate transition portions. A right planar portion 284 is separated from a central planar portion 286 by a first curvate transition portion 290, and the central planar portion 286 is separated from a left planar portion 288 by a second curvate transition portion 292. The three planar portions are not co-planar. When the prosthesis is properly implanted in an intervertebral space, the planar portions are perpendicular to a coronal plane of the vertebral bodies when the implant is properly implanted in an intervertebral space. An angle b1, the angle between the right 264 and central 286 planar portions, is acute and is equal to an angle b2, the acute angle between the central 286 and left 288 planar portions. In alternate embodiments, angles b1 and b2 may be unequal to provide a scoliotic correction.

Two notches are formed in the lateral sides of the nucleus, a left notch 300 and a right notch 302. The left notch 300 defines a left gap 304, through which left flange 134 extends when the nucleus is positioned between the end plates 102, 104. The right notch 302 defines a right gap 306, through which the right flange 135 may extend. Each gap 304, 306 is wider in an anterior-posterior dimension than its respective motion stop, to allow translation of the superior end plate 102 relative to the nucleus 106 and the inferior end plate. FIG. 8 is a lateral view of the left side of the prosthesis, illustrating the relationship of the left flange 134 to the left notch 300 as the prosthesis is in a low-energy neutral position with respect to rotation about both an anterior-posterior axis and a medial-lateral axis. Arrows indicate anterior-posterior translation of the superior end plate 102. A recess 296, visible in FIG. 5A, may be formed in the anterior end 254 toward the superior side 250 of the nucleus. The recess is shaped to receive the anterior retention member 140 of the superior end plate 102 during translation of the superior end plate.

Referring to FIG. 5B, a pocket 310 is formed as a recess into the inferior side 252 of the nucleus 106, and is shaped to receive the post 180. Pocket 310 is shaped as a tapered slot,

with a medial-lateral maximum opening dimension 312 which is greater than an anterior-posterior maximum opening dimension 314. A support wall 316 which circumscribes the pocket 314 tapers outward from an end wall 318 of the pocket to its opening 319. The support wall 316 may articulate with the circumferential wall 182 of the post 180. The ovoid shape and sloping support wall permit the nucleus 106 and the superior end plate 102 freedom to move relative to the post 180 during lateral bending.

Prosthesis 100 comprises a combination of articular surfaces and motion stops which allow the flexion-extension rotational degree of freedom and anterior-posterior translation on a first joint and the lateral bending and axial rotation degrees of freedom on a second joint. The centers of rotation for each individual rotational degree of freedom may be shared, or each rotational degree of freedom may have a different center of rotation. The first joint comprises the interface between the nuclear superior articulation surface 262 and the inferior articular surface 132 of the superior end plate 102. During flexion-extension, the nuclear superior articulation surface 262 articulates with the inferior articular surface 132. Flexion is limited when the anterior planar portion 264 contacts the inferior articular surface 132, and, conversely, extension is limited when the posterior planar portion 268 contacts the inferior articular surface 132. The first joint also permits anterior-posterior translation of the superior end plate 102 relative to the nucleus 106 and the inferior end plate 104.

The second joint comprises the interface between the nuclear inferior articulation surface 280 and the superior articular surface 164 of the inferior end plate 104. During lateral bending, the nuclear inferior articulation surface 280 articulates with the superior articular surface 164. Left lateral bending motion is limited when the left planar portion 288 contacts the superior articular surface 164, and right lateral bending motion is limited when the right planar portion 284 contacts the superior articular surface 164. Axial rotation also occurs on the second joint, as the nuclear inferior articulation surface 280 rotates relative to the superior articular surface 164 around the axis of the post 180. This axial rotation motion may be limited by the angled inner edges of the anterior 170 and posterior 166 retention members on the inferior end plate 104.

Referring to FIGS. 9A, 9B, and 9C, alternate embodiments of artificial disc nuclei are illustrated in lateral cross-sectional views. FIG. 9A illustrates a nucleus 350 in which the upper and lower surfaces 352 and 354 are parallel to each other and an angle between them is 0 degrees. In this nucleus, an axis of greatest height 356 falls in the center of the disc. In FIG. 9B, a nucleus 360 that provides 3° of lordotic correction is illustrated. FIG. 9C illustrates another artificial disc nucleus 370 having 6° of lordotic correction. When deformity correction is provided as shown in FIGS. 9B and 9C, the axis of greatest height 356 may shift to a location that is offset from the geometric center of the nucleus. If the anterior/posterior directions are reversed, a kyphotic correction is provided. It is apparent that the nucleus can be adjusted to provide various degrees of correction and, in certain cases, if no degree of correction is needed. Nuclei 350, 360, 370 may be combined with end plates 102, 104 or other end plates to form artificial disc prostheses. Nucleus 106 comprises 6° of lordotic correction.

The middle planar portions on each nuclear articulation surface may provide each joint with a preferred orientation or stable low energy position. A low energy position is not the same as a motion limited position, from which motion of the joint in a particular direction is prohibited after a certain point, i.e. past a motion stop. Instead a low energy position is

an orientation of a joint into which the joint tends to settle, and energy must be expended to move the joint out of to the low energy position. FIG. 10A is a sagittal cross-sectional view of prosthesis 100 with a joint between the superior end plate 102 and the nucleus 106 in a low energy position in the flexion-extension degree of freedom. Inferior articular surface 132 is in surface contact with middle planar portion 266, providing a preferred orientation and low energy position of the prosthesis across a coronal plane of the superior and inferior end plates 102, 104. In order for the joint to move out of the low energy position, sufficient energy will have to be applied to the superior end plate 102 to overcome resistance and rotate anteriorly across the coronal plane over the first curvate transition portion 270 in flexion or rotate posteriorly over the second curvate transition portion 272 in extension. FIG. 10B illustrates the prosthesis of 10A with the joint in extension. The superior end plate 102 is tilted back such that inferior articular surface 132 is in contact with posterior planar portion 268, the extension motion stop.

FIGS. 11A and 11B illustrate coronal cross-sectional views of prosthesis 100 from a posterior perspective, showing the prosthesis in a low energy position in the lateral bending degree of freedom, and in a laterally bent position, correspondingly. In FIG. 11A, the inferior articular surface of the nucleus is in a preferred orientation, in unbroken contact with the superior articular surface 164 of the inferior end plate 104 surrounding the post 180. In order for the prosthesis to move out of this preferred orientation, sufficient energy will have to be applied to laterally rotate the nucleus across the sagittal plane enough to lift one side out of contact with the superior articular surface 164. This position can be seen in FIG. 1B, at the lateral bending stop. FIGS. 12A and 12B illustrates the prosthesis 100 during flexion combined with lateral bending. FIG. 12A is a left lateral view, showing superior end plate 102 tilted forward in flexion, and also shifted forward in translation, and nucleus 106 is in right lateral bending. FIG. 12B is an anterior view, showing superior end plate 102 in flexion and anterior translation and nucleus 106 tilted right in lateral bending. In this position, anterior planar portion 264 of the nucleus is in contact with the inferior articular surface 132 of the superior end plate 102, providing a soft stop to flexion. Right planar portion 284 of the nucleus is in contact with the superior articular surface 164 of the inferior end plate 104, providing a soft stop to lateral bending.

FIGS. 13A and 13B illustrate axial rotation of the nucleus 106 relative to the inferior end plate 104. For clarity of illustration, superior end plate 102 is not shown. FIG. 13A illustrates nucleus 106 in a central, non-rotated position, and FIG. 13B shows the nucleus 106 rotated to the left. The angled inner edges 172, 168 of motion stops 170, 166 limit the rotational motion. Although not illustrated in these figures, it is appreciated that the present invention allows axial rotation to occur in combination with flexion-extension and/or lateral bending and/or anterior-posterior translation.

It is appreciated that other embodiments of the invention may swap or redistribute the combinations and/or locations of the rotational degrees of freedom. For example, one alternate embodiment may include flexion-extension and lateral bending in one joint and axial rotation in the other joint. Another embodiment may include flexion-extension and axial rotation in one joint, and lateral bending in the other joint.

FIG. 14 illustrates an alternative embodiment of the invention, an artificial disc prosthesis 400 comprising a superior end plate 402, an inferior end plate 404, and a core, or nucleus 406. The superior end plate comprises a superior surface adapted for bony contact and an at least partially cylindrical surface on an inferior surface to articulate a superior surface

of the nucleus. The nucleus includes an at least partially cylindrical superior surface and a planar inferior surface and a cylindrical outer surface. The inferior end plate comprises a planar superior surface which articulates with the inferior surface of the nucleus, and an inferior surface that is adapted for bony contact and a cylindrical inner surface. A first joint of the prosthesis allows flexion-extension and lateral bending degrees of freedom, and a second joint allows the axial rotation degree of freedom.

FIG. 15 illustrates an exploded view of prosthesis 400 from an anterior-inferior perspective, and FIG. 16 illustrates an exploded view of the prosthesis from a posterior-superior perspective. Superior end plate 402 comprises an anterior end 410, a posterior end 412, a left lateral side 414 and a right lateral side 416. A gripping recess 417 may be located on either or both lateral sides. A superior bone engagement surface 418 is adapted for bony contact, and a plurality of self-cutting teeth 420 and/or 421 may be distributed on the bone engagement surface 418. Both the bone engagement surface and the teeth may incorporate bone ingrowth or ongrowth treatments as previously set forth. An inferior articular surface 424 comprises a flattened portion shaped as a partial cylinder. A post 430 extends caudally from the inferior articular surface, comprising post articular surface 432 which may incorporate a flattened section portion. Flattened lateral portions 426, 428, which may be planar, flank the inferior articular surface 424.

Inferior end plate 404 comprises an anterior end 440, a posterior end 442, a left lateral side 444 and a right lateral side 446. Gripping recesses 417 may be located on the lateral sides. An inferior bone engagement surface 450, which may be planar, is on an inferior side 448, and may comprise a plurality of self-cutting teeth 420, 421. The teeth and bone engagement surface may comprise areas incorporating bone ingrowth or bone ongrowth treatments. Referring to FIG. 16, a planar superior articular surface 456 is on a superior side 452 of the end plate. An anterior motion stop 460 extends along the anterior end 440 and cephalad toward the superior end plate 402. An inner surface 462 is cylindrical to correspond with a cylindrical outer edge of the nucleus 406, and an upper surface 464 is shaped as a portion of a cylinder to mate with the inferior articular surface 424 of the superior end plate 402 during flexion. A posterior motion stop 466 similarly comprises a cylindrical upper surface 468 to mate with the inferior articular surface 424 during extension. The posterior motion stop 466 further comprises a cylindrical inner surface 470, and an undercut 472 which is shaped to receive a tab on the nucleus 406. Right and left lateral motion stops 474, 476, comprising angled upper surfaces extend toward the superior end plate 402. Dovetailed inner surface 478, 480 on the right 474 and left 476 stops allow limited axial rotation of the nucleus relative to the inferior end plate 404.

The nucleus 406 comprises a superior side 490 with a partially cylindrical superior articular surface 492, and an inferior side 494 with a planar inferior articular surface 496. An anterior end 497 is cylindrical to correspond with the anterior motion stop 460 of the inferior end plate 404. A cylindrical posterior end 499 comprises a tab 498 shaped to fit in the undercut 472 on the inferior end plate 404. The tab 498 operates to resist posterior migration (i.e., expulsion) of the nucleus toward the spinal canal by preventing "lift off" of the nucleus from the inferior end plate and possible dislocation of the nucleus. As shown, the tab 498 can be rounded, chamfered or beveled in order to facilitate initial insertion and intra-operative or post-operative replacement of the nucleus.

The superior articular surface 492 comprises three flattened sections, each of which is shaped as a portion of a



cylinder. Central flattened section **500** extends medial-laterally across the nucleus, crossing a sagittal plane of the prosthesis. A first curvate transition portion **502** lies between the central section **500** and an anterior flattened portion **504**, while a second curvate transition portion **506** lies between the central section **500** and a posterior flattened portion **508**. A generally centrally located pocket **510** extends caudally into the nucleus, and may be configured to be larger than the post both medial-laterally and antero-posteriorly, to allow limited translation of the superior end plate **402** during flexion-extension and lateral bending. In an alternative embodiment of the invention, the pocket **510** may be smaller so that it contacts the post **430** to form motions stops for flexion/extension and/or lateral bending. Another alternative embodiment may comprise a two piece prosthesis wherein the nucleus **406** is joined with the inferior end plate **404**, and superior articular surface **492** articulates with inferior articular surface **424** of superior end plate **402**.

FIG. 17A illustrates a sagittal cross-sectional view of prosthesis **400** in a preferred orientation position, FIG. 17B illustrates the prosthesis in flexion, and FIG. 17C illustrates the prosthesis in extension.

FIGS. 18-20 illustrate another alternate embodiment of the invention, an artificial disc prosthesis **600**. Prosthesis **600** permits the lateral bending degree of freedom on a first upper joint, and the flexion-extension and axial rotation degrees of freedom on a second lower joint. The prosthesis comprises a superior end plate **602**, and inferior end plate **604**, and a core or nucleus **606** which is positioned between and articulates with the end plates.

FIG. 19 illustrates an exploded view of prosthesis **600** from a superior perspective, and FIG. 20 illustrates an exploded view from an inferior lateral perspective. Superior end plate **602** comprises a planar bone engagement surface **608**, and a plurality of self-cutting teeth **610**, **611** may be formed on the bone engagement surface. On an inferior side of the end plate **602** is formed a partially cylindrical inferior articular surface **612**. An anterior retention member **614** is formed on an anterior end, and has an angled surface **616** which is angled medial-laterally to permit lateral bending during flexion. Gripping slots **618** are formed behind the retention member **614** as gripping features for instruments during implantation, revision and/or removal of the prosthesis. A pocket **620** is formed into the anterior portion of the retention member **614** and serves as a receptacle for instrumentation. A posterior end of the end plate **602** may be slightly angled to assist in insertion into the intervertebral space.

Inferior end plate **604** comprises a planar bone engagement surface **624** upon which may be formed a plurality of self-cutting teeth **610**, **611**. Similar to the superior end plate **602**, a posterior end of the end plate may be slightly angled, so that during insertion into the intervertebral space the posterior ends of the end plates form a reduced cephalad-caudal profile. A superior side of the inferior end plate **604** comprises a superior articular surface **626**, which in turn comprises three flattened portions separated by curvate transition portions. The flattened portions, anterior planar portion **628**, middle planar portion **630**, and posterior planar portion **632** are not co-planar with respect to one another, and are perpendicular to a sagittal plane of the vertebral bodies when prosthesis **600** is properly implanted in an intervertebral space. Middle planar portion **630** cooperates with a planar inferior surface of the nucleus to provide a neutral low energy position or preferred orientation of the prosthesis in the flexion-extension degree of freedom. The anterior planar portion **628** forms a soft motion stop when it contacts the planar inferior surface of the nucleus during flexion, and the posterior planar portion

**632** forms a soft motion stop when it contacts the planar inferior surface of the nucleus during extension. A post **634** protrudes from the superior articular surface **626** and cooperates with a pocket in the nucleus to permit anterior-posterior translation during flexion-extension. An anterior retention member **636** protrudes from the end plate **604** toward the opposite end plate **602**, and a pocket **621** is formed in the anterior end of the end plate inferior to the anterior retention member. Left **638** and right **640** lateral motion stops are formed on the lateral edges of the end plate. Each of the left and right lateral motions stops includes a tri-sloped upper surface, to permit flexion-extension during lateral bending, and vice versa. Inside edges of the anterior **636**, left **638** and right **640** motion stops are also angled to permit axial rotation of the nucleus about the axis of the post **634**. Alternative embodiments of the inferior end plate **604** may incorporate a lordotic or kyphotic correction such that a maximum vertical axis of the end plate is displaced anteriorly or posteriorly from the center of the end plate.

The nucleus comprises a planar inferior articular surface **642** and a semi-cylindrical superior articular surface **644**. The planar inferior articular surface **642** articulates with the superior articular surface **626** of the inferior endplate to provide flexion-extension and axial rotation, and the superior articular surface **644** articulates with the inferior articular surface **612** of the superior end plate **602** to provide lateral bending. An elongated pocket **646** is recessed into the inferior side of the nucleus, and is shaped to receive the post **634**. A curved tab **648** projects posteriorly from the nucleus with an undercut **649** formed under the tab.

A separately formed retention element **650** which is joined to the superior end plate **602** by welding or other means may engage with the nucleus **606** to retain the nucleus **606** in the prosthesis and also to serve as a motion stop. The retention element **650** comprises a body **652**, a pair of arms **654** and a projection **656**. The projection **656** fits into the undercut **649** on the nucleus, and the arms **654** fit over the curved tab **648**. During spinal motion, the retention element moves with the superior end plate. The inferior surfaces of the body **652** and projection **656** are angled to allow both lateral bending and extension.

The intervertebral disc implants depicted in FIGS. 1-20 may be formed of biocompatible materials such as bio-compatible metals or other suitable strong materials. An implant may be formed of one biocompatible material while the bearing surface comprises another biocompatible material. The implants may be constructed in a variety of footprint sizes, and a variety of shapes, to fit the variations found in patient vertebral sizes and vertebral shapes. Specifically, each implant may be available in three footprint sizes: small, medium, and large, and in three corrective lordotic angles: 0°, 3°, and 6°.

The implant components may be formed wholly or partially of any biocompatible metal, such as stainless steel, Titanium, Titanium alloys, Cobalt Chrome, CCM (Cobalt Chrome Molybdenum), Aluminum, Zirconium, Nickel Titanium (NiTi/Nitinol), shape memory metals, superelastic metals, metal matrix composites such as Titanium Carbide, Tungsten Carbide, Tantalum, or Chromium, among others. The implant components can be formed wholly or partially of a biocompatible ceramic material such as alumina, zirconia, alumina-zirconia blends, or other ceramic composites. The implant components can be formed wholly or partially of a biocompatible polymer such as PEEK, carbon or glass-fiber reinforced polymers, ABS, polycarbonate, polyethylenes, ultra high molecular weight polyethylene (UHMWPE), nylons, polymer composites, polyurethane, polycarbonate-

polyurethane composites, acetals, polyesters, polypropylene, PTFE, ePTFE, absorbable polymers such as poly L-lactic acid (PLLA), polylactic acid (PLA), polyglycolic acid (PGA), TCP, glycolides, lactides, hydrogels, elastomers such as silicone, nitrile, butyl, thermoplastic elastomers (TPE's), or ethylene vinyl acetate (EVA), among others.

The implant components can be formed wholly or partially of another biocompatible material including diamond or diamond-like materials, carbon, hydrogels, pyrocarbon, pyrolytic carbon, allograft bone, demineralized bone, collagen, cartilage, tricalcium phosphate, calcium phosphate, hydroxyapatite, PMMA—bone cement, proteins, amino acids, nucleic acids, or sugars, among others.

The implant components may also be coated wholly or partially with specialized coatings such as Titanium Nitride, Titanium Boride, Titanium Carbide, ion-based coatings, ceramic coatings, oxide coatings, plasma, PTFE coatings, low-friction coatings, hydrophobic or hydrophilic coatings, or vapor deposition coatings, among others. Bone-contacting portions of implant components may comprise porous or non-porous bone ingrowth surfaces.

In another aspect of the invention, all of the articulating surfaces of the prosthesis can be formed of a polymer. As discussed above, the nucleus can be formed entirely of a polymer such as, for example, ultra-high molecular weight polyethylene ("UHMWPE"), a cross-linked UHMWPE, a ceramic, polyetheretherketone ("PEEK") or other type of suitable polymer. The bony ingrowth surfaces can be made from plasma sprayed metals, hydroxyapatite or similar bone-like coatings, and can include a coating of bone growth factors. The articulating surfaces of the end plates can be formed with inserts of an appropriate polymer, ceramic or the like. The remaining exterior surfaces of the end plates that interface with bone can be formed with bony ingrowth surfaces of the type discussed above.

FIGS. 21-41 illustrate instrumentation and methods for implanting an artificial disc prosthesis such as prosthesis 100 into a portion of a spine. A kit of tools, including implant trials in a variety of sizes, may be provided. Referring to FIG. 21, the patient is prepared in a neutral posture position, and the target disc level of the spine is exposed from an anterior approach. A partial discectomy is conducted in a targeted intradiscal space between superior vertebral body 2 and inferior vertebral body 4. Although cervical vertebral bodies 2 and 4 are depicted in the illustrations as the C4 and C5 level vertebrae, it is appreciated that the procedure could be performed on other vertebral pairs in the spine.

Referring to FIG. 22, a sagittal midline 6, or central midline axis of the vertebral bodies is determined and may be marked on the exposed vertebral bodies. A guide tool 700 is preliminarily positioned on the vertebral bodies, aligning sagittal indicators 702, 704, 706 with the sagittal midline 6 when viewed from a viewpoint normal to the coronal plane. Alternatively, a line may be determined which is not on the sagittal midline but is parallel to the sagittal midline, and the guide may be aligned to this offset line instead.

FIG. 23A illustrates guide tool 700 in its entirety, FIG. 23B illustrates an enlarged side view of a guide head 710, and FIG. 23C illustrates an enlarged perspective view of the guide head. Guide tool 700 comprises a handle 712 which comprises a proximal gripping portion 714 and a distal shaft portion 716. The shaft 716 is welded to the head 710. The guide head 710 is shaped as an elongated loop and comprises a circumferential wall 718 which defines a guide lumen 719. The head 710 has a first side 720 and a parallel second side 722, through which ports 724 and lateral alignment holes 726 open. A guide tab 728, which includes the sagittal indicator

706, protrudes distally and is connected to both first 720 and second 722 sides. As seen in FIG. 22, the guide tool 700 may be first positioned such that the guide tab 728 protrudes into the space created by the partial discectomy and the sagittal indicators are lined up with the sagittal midline 6. The guide tool 700 is further manipulated so that the lateral alignment holes 726 on side 720 align with the lateral alignment holes 726 on side 722, appearing concentric with one another when viewed from a viewpoint normal to the sagittal midline. In this way, the guide head is accurately positioned relative to three orthogonal planes, in a preferred orientation parallel to the sagittal plane and perpendicular to the coronal plane of the vertebral bodies. Fluoroscopy may be used to determine and direct the alignment processes. Another embodiment of the invention may comprise a single lateral alignment hole 726 on each side 720, 722.

Referring to FIGS. 24 and 25, an awl 750 may be used to create pilot holes in the vertebral bodies. A distal end 752 and tip 754 of the awl 750 are shaped to fit through the guide lumen 719. The tip 754 of the awl may be used to penetrate each of the vertebral bodies 2, 4, along the midline and approximately mid-body, creating pilot holes for guide pins.

Referring to FIGS. 26 and 27, a guide pin 762 is inserted through the guide lumen 719 of the head 710 and driven into vertebral body 2 on the sagittal midline and a guide pin 764 is driven into the adjacent vertebral body 4 on the sagittal midline, the pins co-planar with one another, using the pilot holes if necessary. Guide pins 762 and 764 may be identical, or may differ in length. Guide pins 762, 764 each comprise a distal threaded penetrating tip 770, a distal shaft portion 772, a middle shaft portion 774 and a proximal shaft portion 776. A recessed groove 775 encircles the shaft, providing an interface for connection to other instruments. A driver engagement interface 778 is configured to engage with a corresponding drive feature 782 on a driver tool 780, which is rotated to drive and each pin 762, 764 into its respective vertebral body. The interface 778 and corresponding drive feature 782 may be shaped as a hexagon or another shape. The guide pins 762, 764 are implanted on the sagittal midline approximately mid-body and parallel to the target disc space. Once the guide pins are secured, the guide 700 tool may be removed.

Referring to FIGS. 28 and 29, a retainer 800 is placed on the pins 762, 764. The retainer 800 is an adjustable bracket system which may be placed in engagement with the pins 762, 764 to adjust and maintain a distance between the pins and the vertebral bodies in which the pins are secured, thereby providing an accessible working area in the intervertebral space between the targeted vertebral bodies. A rack and pinion system provides compressive force or distractive force to urge the pins and therefore the vertebral bodies together or apart. The retainer 800 also provides a guiding framework for additional instruments, permitting the instruments and prostheses to be placed in a preferred orientation with respect to the sagittal midline of the vertebral bodies. Referring to FIG. 28, the retainer 800 comprises a first bracket 802, a second bracket 804, a rack and pinion system 806, and two plates 808, 810 which are configured to fit over and engage the pins 762, 764. Plate 808 may be fit over pin 762 and locked to the pin by engaging a lock 809, and plate 810 may be fit over pin 764 and locked to the pin by engaging a lock 811. Each lock 809, 811 comprises a tab 813 which is rotated in one direction into engagement with the groove 775 on the respective pin to provide a locked configuration, and may be rotated in the opposite direction to provide an unlocked configuration. A pair of links 812, 814 hingedly connect the plates 808, 810 to the brackets 802, 804. Between the plate 810 and the second bracket 804 is an additional link 816 and a pivot pin 817,

around which plate **810** which may be pivoted to allow angular movement of plate **810** and pin **762** during prosthesis implantation, revision and/or removal procedures. A collar **818** is slidable between a first position, seen in FIG. **28**, in which it prevents pivoting of plate **810** around the pivot pin, and a second position in which plate **810** is free to pivot. When plate **810** is allowed to pivot, the angularity of plate **810**, pin **762** and associated vertebral body **2**, may be adjustable out of a parallel position relative to plate **808**, pin **764** and associated vertebral body **4**. This adjustability may be useful or necessary during the insertion of trials into the intervertebral space, or during other steps of the implantation procedure.

FIGS. **29A-29C** illustrate cross-sectional views of the brackets **802**, **804** and the rack and pinion system **806**. The rack and pinion system **806** is housed inside a bracket housing **805**, although the rack may extend out of the housing. The rack and pinion system **806** includes a rack **820** with a row of rack teeth **822**. The rack **820** is rigidly connected to the first bracket **802** by welding or other means, and passes through the housing **805**. A spring-loaded stop arm **821** extends from the rack and prevents the rack from being unintentionally withdrawn from the housing **805**. When withdrawal of the rack from the housing is desired, the stop arm **821** may be depressed toward the rack **820**, compressing a spring **823**. A pinion **824** includes pinion teeth **826** and may be turned by a pinion wing **828** (seen in FIG. **28**). The position of a pawl **830** controls whether the retainer provides ratcheting compressive or distractive force to the pins **762**, **764**, and the pawl is movable between a first position, a second position, and a third neutral position. The pawl **830** comprises a first pawl tooth **832**, a second pawl tooth **834**, and is pivotable about a pivot pin **836**. A toggle **838** may be switched between the first, neutral and second positions, controlling a spring **840** and plunger **842** which engage the pawl **830**, moving it between the first, neutral and second positions. FIG. **29A** shows the toggle **838** and the pawl **830** in the neutral position. In the neutral position, the pawl is not engaged with the rack teeth **822**, and the rack **820** can move in either direction relative to the second bracket **804** by turning the pinion **824** to engage the rack. To attain the first, or distraction, position, the toggle **838** is moved in a first direction **850** such that the plunger **842** may depress the first pawl tooth **832** into engagement with the rack **820**, as shown in FIG. **29C**. With the pawl in this first position, the rack **820** can only move in direction **852** relative to the second bracket **804** as the pinion **824** is turned to engage the rack. Since the rack **820** is connected to the first bracket **802**, first bracket **802** also moves in direction **852** relative to the second bracket **804**, moving the brackets **802**, **804** away from one another. Since brackets **802**, **804** are linked to plates **808**, **810** locked to the pins **762**, **764**, movement of the rack in direction **852** results in distraction of the pins **762**, **764** and the vertebral bodies **2**, **4**.

Referring to FIG. **29B**, when the toggle **838** is moved past the neutral position in a second direction **852**, plunger **842** may depress the second pawl tooth **834** into engagement with the rack **820**, placing the pawl **830** in a second, or compression, position. With the pawl in this second position, the rack **820** can only move in direction **850** relative to the second bracket **804** as the pinion **824** is turned to engage the rack, thereby moving brackets **802**, **804** closer together. Movement of the brackets **802**, **804** closer together results in compression of the pins **762**, **764** and the vertebral bodies **2**, **4**. Before the retainer is placed on the pins **762**, **764**, the pawl **830** may be placed in the neutral position, permitting the rack to move freely in either direction, and allowing a distance between the brackets and plates to be adjusted to match a distance between the pins. The plates **810**, **808** are placed over the pins **762**, **764**

and the locks **809**, **811** are engaged to lock the plates to the pins. The driver tool **780** may be used to engage the locks **810**, **811**. Then, distraction or compression may be accomplished by the methods described above, i.e., the toggle **838** is moved to the first position and the pinion is turned to provide only distraction, the toggle **838** is moved to the second position and the pinion is turned to provide only compression. Alternatively, the toggle **838** may be placed in the neutral position to allow unconstrained distraction and/or compression. It is appreciated that the retainer **800** may be placed over the pins **762**, **764** in either direction, that is, plate **808** may be placed over pin **764** and plate **810** over pin **762**, or alternately, plate **810** may be placed over pin **764** and plate **808** over pin **762**. It is also appreciated that in an alternative embodiment of the invention, each bracket may comprise an adjustable feature such as a rack and pinion system, to provide distraction and compression between the brackets, pins and associated vertebral bodies. In addition, a pivoting feature such as pivot pin **817** and collar **818** could be on either or both plates.

As seen in FIG. **28**, link **812** connects plate **808** with bracket **802**, and links **814** and **816** connect plate **810** with bracket **804**. The links and brackets may be hinged so that they may be rotated about the cephalad-caudal axis of the vertebrae, toward one lateral side or the other, allowing for optimal visibility and access to the surgical site.

As seen in FIG. **30**, a distractor **900** may be used with the retainer **800** to aid in providing sufficient distraction between the vertebral bodies **2**, **4**, if necessary or desired. Prongs **902**, **904** of the distractor **900** may be inserted into the intervertebral space, and levers **906**, **908** compressed together to provide distraction. A ratcheting mechanism **910** allows the levers to be locked in a fixed position, and a leaf spring **912** provides the resistance for the distraction. Such distraction may be provided while the retainer pawl **830** is in the neutral position or in the first position. Once the vertebral bodies are sufficiently distracted, the retainer pawl **830** may be moved to the first position if not already there, to maintain the spacing between the vertebral bodies. Distractor **900** may comprise a locking feature to hold the levers **906**, **908** and prongs **902**, **904** in a fixed position, until released.

After the vertebral bodies are sufficiently distracted, a discectomy and decompression may be performed using instruments known in the art such as rongeurs, curettes and osteotomes. Bone rongeurs, planers, rasps, burr tools or other instruments may be used to prepare flat surfaces on the vertebral endplates, as flat surfaces may ensure the best interface between the prosthesis end plates and the vertebral endplates. Endplate preparation may also include forming grooves to correspond with teeth or keels of a prosthesis, roughening or smoothing the surface to enhance conformance with the prosthesis or encourage bony ingrowth and stabilization of the prosthesis, and/or contouring the shapes of the endplates. FIG. **31** illustrates a rasp **950** which may be inserted between the vertebral bodies **2**, **4** to scrape and flatten the endplates. Rasp **950** comprises a gripping portion **952**, a shaft **954**, a pair of wings **956** and a rasp head **958**. The rasp head comprises a plurality of cutting edges **964**, which may be undercut and each of which may be adjacent an opening **965**, which during rasping may allow cut material to flow through to the opposite side of the head and not clog the cutting edges. Additionally, the cutting edges may cut only in the posterior-to-anterior direction, making insertion into the intervertebral area easier and less traumatic than it would be with a rasp which cuts in the anterior-posterior direction. The wings **956** comprise wing plates **960**, **962** which flank either side of the shaft **954** and are aligned perpendicular to the rasp head **958**. The wings **956** are a guiding feature which allow the rasp **950** to be

inserted into the intervertebral space in alignment with the retainer **800**, along a pathway substantially parallel with the pins **762, 764**. With reference to FIG. **28**, the rasp **950** may be inserted between the plates **808, 810** such that the wing plates **960, 962** slide over retainer plates **808, 810** in a fixed orientation. With the rasp **950** thus aligned, the rasp head **958** will enter the intervertebral space in an preferred orientation parallel to the vertebral endplates and relative to the sagittal plane. It is appreciated that other instruments including but not limited to a planer, blade, grater, or cutter could have a guiding feature comprising similar wing plates, permitting alignment with the retainer plates **808, 810** and correct orientation of the instrument relative to the sagittal plane. FIG. **32** illustrates a planer which may also be used in endplate flattening and preparation in an alternative embodiment. Planar **970** comprises a gripping portion **972**, a shaft **974**, a pair of wings **976** and a planer head **978** with a cutting edge **979**.

Referring to FIG. **33**, a feeler **980** may be employed to evaluate the configuration of the intervertebral space, to assess endplate flatness and determine which implant footprint best fits the space. The feeler **980** comprises a handle **982**, a shaft **984** and a paddle **986** with flat sides. The feeler may be available in a plurality of sizes such as small, medium and large, each size comprising a paddle with a comparable footprint size to a prosthesis such as prosthesis **100**. As seen in FIG. **33**, the feeler may be inserted between the plates **808, 810** of the retainer until the paddle **986** is in the intervertebral space. Visual observation or fluoroscopy may be used to observe the size of the paddle **986** relative to the vertebral endplates, to determine the correct prosthesis footprint size. The paddle **986** may be pressed or rubbed against the prepared vertebral endplates to assess flatness of the endplates, and/or fluoroscopy may be used to observe the profiles of the endplates compared to the profile of the paddle to assess flatness. The feeler may be available in a variety of sizes, and other embodiments of the feeler may include wings such as those on the rasp **950** to allow precise guidance by the retainer **800**. Once the flatness of the vertebral body endplates is assessed, additional preparation with a rasp, planer, hammer, burr and/or other tools may occur if necessary to relieve concavities, convexities, or other irregularities on the endplate surfaces. These steps of assessment and preparation may be repeated as needed.

Referring to FIGS. **34-36**, a trial or trials may be inserted into the prepared intervertebral space to determine the lordotic correction, if any, that is needed. Trials are available in a variety of footprint sizes, matching the feeler and prosthesis footprint sizes. Alternative embodiments of trials may include those shaped as intervertebral disc replacements, fusion cages, spacers, or other intervertebral implants. FIG. **34** illustrates a trial **1010**, and FIG. **35** illustrates a partially exploded view of a distal end of the trial. Trial **1010** comprises a head **1000** with first trial plate **1002** and a second trial plate **1004**. Trial plate **1002** has a peg **1006** (not visible in FIG. **35**) which joins it to a first lever **1012**, and trial plate **1004** has a peg **1007** joining it to a second lever **1014**. The plates **1002, 1004** may be secured to the inserter by inserting each peg through a corresponding hole in the distal end of each lever. Alternately, the plates may be permanently welded to the levers.

Trial **1010** further comprises a first lever **1012** and a second lever **1014**. At their proximal ends, the levers **1012, 1014** are joined by a ratcheting mechanism **1016**. Near their distal ends, the levers are linked by a rivet **1015**. Rivet **1015** is joined to lever **1012** and captured in a slot **1017** on lever **1014**, such that the levers can move relative to one another but such movement is constrained by the length of the slot **1017**. First

lever **1012** comprises a first wing **1018**, and second lever **1014** comprises a second wing **1019**, the wings positioned so that the inserter may be slid over the plates of the retainer **800**, positioning the inserter with respect to the pins **762, 764** and the targeted intervertebral space. A pivot pin **1020** joins the levers **1012, 1014** at their distal ends, allowing the levers to rotate about the pin **1020** and pivot relative to one another.

FIG. **36** illustrates insertion of the trial **1010** into the intervertebral space between the prepared endplates. A trial is chosen with an appropriate footprint size determined by use of the feeler. The proximal ends of the levers are positioned so that the distal ends are approximately parallel to one another, so that the trial plates **1002, 1004** are also parallel with respect to one another. The trial **1010** is inserted between the retainer plates **808, 810**, and the levers are positioned so that the wings **1019, 1018** flank the plates **808, 810**, thereby positioning the head **1000** in a preferred orientation relative to the sagittal plane. The head **1000** is further inserted, into the intervertebral space. Fluoroscopy may be used to place the head at a desired depth within the intervertebral space.

The desired degree of lordotic correction may be determined by adjusting the angle of the trial plates **1002, 1004** within the intervertebral space. Levers **1012, 1014** are ratcheted together, causing their distal ends to pivot apart around the pivot pin **1020**, and causing trial plates **1002, 1004** to pivot apart until the desired angle, or degree of lordotic correction is reached, which may be visualized through fluoroscopy. A reference feature, which may comprise markings and/or alignable holes on the trial **1010** may also be used to measure the degree of lordotic correction. Once the degree of lordotic correction is determined, the trial inserter **1010** may be released, allowing the trial plates **1002, 1004** to return to a parallel position for removal, and the trial **1000** is removed from the intervertebral space. Observations of footprint size and degree of lordotic correction may be used to select a properly configured prosthesis for implantation. Another embodiment of the trial may include a shaft which is distally displaced to pivot the trial plates.

One reference feature on the trial may comprise holes located on the first lever, which may be coaxial with a slot on the second lever to indicate an angulation or degree of lordotic correction. First lever **1012** comprises an array of holes **1022**, and second lever **1014** comprises an elongated slot **1024**. When the first and second levers are at one position relative to one another, and therefore the plates are at one angle, a first hole in the array **1022** is coaxial with the slot **1024**. When the first and second levers are at a second position, and thus the plates at a second angle, two holes in the array **1022** are coaxial with the slot **1024**. When the first and second levers are at a third position, and thus the plates at a third angle, three holes in the array **1022** are coaxial with the slot **1024**. It is appreciated that in other embodiments of the invention, the array may comprise more or less than three holes, and the array and the slots may be situated at various locations on the trial. The alignment of the array with the slot may be viewed from a viewpoint normal to the array, and may be viewed unaided or may be viewed through the use of fluoroscopy. Alternatively, or in addition to the coaxial holes and slot, markings **1026** on the ratcheting mechanism may indicate the angulation or degree of lordotic correction.

FIGS. **37-41** illustrate the insertion of an intervertebral disc prosthesis **100** into the prepared intervertebral space between vertebra **2** and **4**. It is appreciated that the methods and instrumentation presented herein could be used to implant prostheses **400, 600** or other similar artificial disc prostheses. Referring to FIG. **37**, an implant inserter **1050** is shown, gripping the prosthesis **100**. Implant inserter comprises a rotatable

handle portion **1052**, a fixed handle portion **1053**, a shaft **1054**, wings **1056**, and a gripping mechanism **1058**. The shaft **1054** comprises an outer tube **1060** and a rod **1062** positioned inside the tube. The outer tube **1060** may comprise a plurality of cleaning slots **1061**. The rotatable handle portion **1052** is connected to the rod **1062** such that turning the rotatable handle portion **1052** moves the rod **1062** distally or proximally. At its distal end, the rod is connected to the gripping mechanism **1058**. When the rod **1062** is displaced distally to a first position, it cams the gripping mechanism **1058** into an open position, and when the rod is displaced proximally to a second position, the gripping mechanism is cammed into a closed position in which the prosthesis **100** may be securely gripped for implantation. The wings **1056** are configured to slide over and flank the retainer plates **808**, **810** during implantation to place the instrument and prosthesis in a preferred orientation relative to the sagittal plane.

Referring to FIGS. **38A-38D**, enlarged views of the distal end of the inserter and the gripping mechanism are shown. The gripping mechanism comprises an alignment member with a first alignment side **1070** and a second alignment side **1072** which is positioned opposite the first. The alignment sides **1070**, **1072** are oriented perpendicular to the wings **1056**, to place the prosthesis in the proper orientation during implantation. The alignment member comprises a plurality of prongs **1074** which extend past the distal end of the respective alignment sides, and between which the prosthesis is sandwiched when gripped by the gripping mechanism for handling and insertion. The prongs may be positioned to line up with teeth on the prosthesis end plates **102**, **104**, for ease of insertion. As the prosthesis is mounted to the inserter, the end plates **102**, **104** may be compressed together into a preferred orientation to sandwich the prosthesis together and then slid between the prongs; this compression may help prevent the intervertebral space from becoming overstuffed with the insertion of the prosthesis. At its distal end, which is shaped to complement the anterior end of the prosthesis end plate **102**, alignment side **1070** comprises a first key **1076**, which is shaped to fit coaxially in a pocket **144** on the anterior end of the end plate **102**. Alignment side **1072** comprises a second key **1078** larger than the first key, shaped to fit coaxially in a pocket **174** on the anterior end of the end plate **104**. The keys and pockets are specifically sized so that the prosthesis can be mounted on the inserter **1050** in only one, correct, position. It is appreciated that other embodiments of the inserter **1050** may include keying features shaped to engage with gripping recesses, pockets, or other features of implants **400** or **600**.

The gripping mechanism further comprises two pivotable opposing arms **1080**, **1082**. The pivotable arms **1080**, **1082** each pivot about an individual pivot pin **1075** which extends through the first alignment side **1070**, the respective arm, and the second alignment side **1072**, such that the proximal portions of the arms **1080**, **1082** are sandwiched between the alignment sides **1070**, **1072**. As seen in FIG. **39**, a proximal end of arm **1082** engages rod **1062** at cam interfaces **1065**, **1067**. On the opposite side (not visible in FIG. **39**), a proximal end of arm **1080** similarly engages rod **1062** at two cam interfaces. The arms partially overlap one another as they pass on either side of the rod **1062**. When the inner rod **1062** is distally displaced, the arms **1080**, **1082** are cammed to an open position to receive the prosthesis **100**, as seen in FIG. **38D**. The prosthesis is mounted to the inserter such that keys **1076**, **1078** on the inserter fit into pockets **144**, **174** on the prosthesis **100**. Referring also to FIG. **39**, the rod is then displaced to a second position to close the arms **1080**, **1082**, which simultaneously engage with the dovetailed inner edges **142**, **172** of motion stops **140**, **170**, gripping the prosthesis

securely. Each arm **1080**, **1082** has an aperture **1084**. The apertures may be observed with fluoroscopy to monitor the prostheses as it is inserted into the intervertebral space, to monitor and determine the proper depth of implantation.

The desired prosthesis is chosen and mounted on the inserter **1050**. The inserter is placed onto the retainer **800**, with guiding wings **1056** over the plates **808**, **810** of the retainer. The leading (posterior) edge of the prosthesis is inserted into the prepared intervertebral space. At this point, the retainer **800** may be compressed slightly to facilitate endplate fixation. The inserter **1050** may be tapped with a hammer or mallet (not shown) to drive the prosthesis farther into the intervertebral space. As the prosthesis is inserted, the leading self-cutting teeth **130** may cut a track into the vertebral endplates, and the larger second row of teeth **131** enlarge the track. Compression and distraction may be adjusted as needed by the retainer to ensure firm implantation of the teeth **130**, **131** into the vertebral endplates. When the implant is adequately placed, the inserter handle **1052** is twisted to release the inserter arms **1080**, **1082** from the implant. The retainer **800** and pins **762**, **764** are removed and fluoroscopy may be used as needed to assess the final implant placement.

If needed, a tamp may be used to finely adjust the implant until it is fully seated. FIG. **40A** illustrates tamp **1100**, which comprises handle **1102**, shaft **1104** and tamp head **1106**. FIG. **40B** is an enlarged view of the tamp head **1106**, which comprises a body **1108**, a distal curved edge **1110** from which protrudes a tab **1112**. The body **1108** may comprise a wider upper portion, a taper and narrow lower portion. The taper and wider upper portion may act as a blocking element prevent the tamp and/or prosthesis from being pushed too far into the intervertebral space. The curved edge **1110** is shaped to complement the curved shapes of the anterior ends **112**, **152** of the end plates **102**, **104** (seen in FIG. **2**). As seen in FIG. **41**, the tab **1112** is shaped to coaxially mate with the pockets **144**, **174** on the end plates. The tamp **1100** may be fitted onto the anterior ends of the end plates **102**, **104** with the tab **1112** in the pockets to ensure proper alignment of the end plates relative to one another, and a correct lateral position of the tamp. The tamp may be struck with a hammer or mallet (not shown) to precisely seat the end plates **102**, **104** in the vertebral bodies. Other embodiments may include single endplate tamps which are configured to seat each end plate individually. Ensuring proper placement and alignment of the prosthesis will allow the patient to have the optimized range of motion. After the implant is seated in the desired position confirmed by fluoroscopy, all instrumentation may be removed and the surgical site closed.

Each implant described herein may be revised or removed in the same or a subsequent procedure. For implant revision or removal, the patient is again prepared in a neutral posture position, and the target disc level of the spine is exposed from an anterior approach. Optionally, the adjustable retainer **800** and pins, or a distractor, may be used to distract the vertebral bodies. FIG. **42** illustrates a remover tool **1150** gripping implant **100** prior to removal. FIG. **43** illustrates a distal end of remover tool **1150** gripping the implant **100**, and FIG. **44** is an exploded view of the distal end of the remover tool **1150**.

Referring to FIG. **42**, remover tool **1150** comprises a first lever **1152** and a second lever **1154** joined at proximal ends by a ratchet mechanism **1156**, and joined at distal ends by a rivet **1158**. A pair of leaf springs **1160**, **1161** provide resistance as the levers are ratcheted together as the implant is gripped. Referring to FIGS. **43** and **44**, a distal end of first lever **1152** comprises a body **1162** with a recess **1164** at the distal most end. Two prongs **1166**, **1168** enclose the recess from opposing sides such that the tips **1170**, **1172** of the prongs oppose

one another but do not meet. The tips **1170**, **1172** are angled to interface with the dovetailed inner edges **142** of anterior retention member **140** of superior endplate **102** (seen in FIG. **3**). The distal end of second lever **1154** comprises a body **1176** with a prying feature comprising a wedge or chisel point **1178**. On an inside face of the body, a lip **1180** and a fillet **1182** extend across the body.

The remover tool **1150** may be opened by releasing the ratchet mechanism and moving the levers **1152**, **1154** apart at their proximal ends, so that the distal ends, rotating about the rivet **1158**, also move apart. The body **1162** of the first lever **1152** is engaged with the implant such that the anterior retention member **140** on the superior end plate **102** fits into the recess **1164**, with the prongs **1166**, **1168** around the member **140** and the prong tips **1170**, **1172** mated, or interfaced, with the dovetailed inner edges **142**. The wedge point **1178** on the second lever **1154** is wedged between the superior end plate **102** and the vertebral body **2**, prying them apart. Alternatively, the wedge point **1178** may be utilized before, or simultaneously, with the engagement of the body **1162** with the superior end plate **102**. The remover tool is closed by ratcheting the levers together, and the bodies **1162**, **1176** move toward one another, sandwiching around the anterior end **112** of the superior end plate **102**. The end plate **102** is securely gripped, as the member **140** is fitted into the recess **1164**, and the fillet **1182** fits around the superior anterior edge of the end plate. The superior end plate **102** is pulled anteriorly out of the intervertebral space, and the nucleus and inferior end plate are pulled out along with the superior end plate, as a result of the close overlapping juxtaposition of the implant components. As the superior end plate **102** is pulled anteriorly, its lateral motion stops **134**, **135** engage the notches **300**, **302** on the nucleus **106**; the pocket **310** in the nucleus engages the post **180** on the inferior end plate **104**; thus the nucleus and the inferior end plate are pulled out along with the superior end plate. After removal of the implant, a replacement prosthesis may be implanted, or the prosthesis may be replaced with a fusion device or other system.

Alternatively, the remover tool may be turned 180° and used to grip the inferior end plate **104**, with the anterior motion stop **170** of the end plate fitting into the recess **1164** of the first lever **1152**, and with the wedge point **1178** inserted between the inferior end plate **104** and the vertebral body **4**. In other alternative scenarios, if the nucleus is not present or the prosthesis has been distracted such that the components are no longer in close juxtaposition, each end plate **102**, **104**, may be removed individually.

The present invention may be embodied in other specific forms without departing from its spirit or essential characteristics. For example, above are described various alternative examples of artificial disc prostheses. It is appreciated that various features of the above-described examples can be mixed and matched to form a variety of other alternatives, each of which may have a different bearing surface configuration or preferred relative orientation according to the invention. As such, the described embodiments are to be considered in all respects only as illustrative and not restrictive. The scope of the invention is, therefore, indicated by the appended claims rather than by the foregoing description. All changes which come within the meaning and range of equivalency of the claims are to be embraced within their scope.

Although the present invention and its advantages have been described in detail, it should be understood that various changes, substitutions and alterations can be made herein without departing from the spirit and scope of the invention as defined by the appended claims. Moreover, the scope of the present application is not intended to be limited to the par-

ticular embodiments of the process, machine, manufacture, composition of matter, means, methods and steps described in the specification. As one of ordinary skill in the art will readily appreciate from the disclosure of the present invention, processes, machines, manufacture, compositions of matter, means, methods, or steps, presently existing or later to be developed that perform substantially the same function or achieve substantially the same result as the corresponding embodiments described herein may be utilized according to the present invention. Accordingly, the appended claims are intended to include within their scope such processes, machines, manufacture, compositions of matter, means, methods, or steps.

The invention claimed is:

1. A system for replacing an intervertebral disc in an intervertebral space between a first vertebral body and a second vertebral body, the system comprising:

an implant including a first end plate and a second end plate, the first end plate having a first retention member protruding from a first internally facing surface of the first end plate, and a first externally facing surface configured to engage the first vertebral body and being opposite to the first internally facing surface, the second end plate having a second retention member protruding from a second internally facing surface of the second end plate, and a second externally facing surface configured to engage the second vertebral body and being opposite to the second internally facing surface, the first retention member and the second retention member each extending and protruding so as to be positioned adjacent each other, the first retention member defining a first pocket and the second retention member defining a second pocket such that the first and second pockets are positioned adjacent each other and such that the second pocket is of a different size than the first pocket; and

an intervertebral implant inserter, the implant inserter comprising a gripping mechanism movable between an open position and a closed position in which the implant inserter is configured to securely grip the implant,

the gripping mechanism having a first arm and a second arm, wherein each of the first and second arms comprises a shaped engagement surface configured to mate with complementarily shaped mating surfaces on the first and second retention members protruding from the respective first and second end plates of the implant to securely grip the implant,

the implant inserter further comprising a rod which engages the first and second arms, wherein the rod is actuatable to pivot the first and second arms relative to one another between the open and closed positions, wherein the first and second arms each pivot about separate pivot axes,

the implant inserter further comprising an intermediate structure positioned between the first and second arms, the intermediate structure having a keying feature having opposing sides shaped to correspond to and to be inserted into and engage with both the first and second pockets defined in the first and second retention members protruding from the first and second internally facing surfaces of the first and second end plates of the implant, wherein the keying feature is independent of the first and second arms, the intermediate structure further including a plurality of prongs extending distally from the intermediate structure, wherein when the implant is gripped by the gripping mechanism, the

31

implant is sandwiched between the prongs and the prongs project over the externally facing surfaces of the implant;

wherein the keying feature is configured to control a position of the implant mounted on the implant inserter such that the keying feature is sized to allow mounting of the implant on the implant inserter in only one position.

2. The system of claim 1, wherein the rod has a first end and a second end;

wherein the second end of the rod engages the first and second arms; and

wherein the first end of the rod is actuable to move the gripping mechanism between the open position and the closed position.

3. The system of claim 2, wherein the rod is longitudinally displaceable between a first distal position in which the arms are in the open position, and a second proximal position in which the arms are in the closed position.

4. The system of claim 1, wherein the arms are L-shaped.

5. The system of claim 1, wherein at least one arm comprises an aperture, the aperture observable with fluoroscopy to determine the orientation of the implant inserter relative to other structures.

6. The system of claim 1, wherein the keying feature comprises a protrusion formed on a distal end of the implant inserter complementarily fitting with the first and second pockets on the implant in only one position.

7. The system of claim 1, wherein the implant is removably mountable on the intervertebral implant inserter to enable insertion of the implant into the intervertebral space between the first vertebral body and the second vertebral body.

8. The system of claim 7, wherein the implant further comprises a nucleus positioned between the first and second end plates.

9. The system of claim 8, wherein the first retention member comprises a first dovetail interface feature and the second retention member comprises a second dovetail interface feature, wherein the first and second dovetail interface features are mating surfaces shaped to complementarily mate with the engagement surfaces on the first and second arms when the gripping mechanism is in the closed position.

10. The system of claim 9, the first end plate further comprising a bone-engaging side and an articular side positioned on the opposite side of the first end plate from the bone-engaging side, wherein the first dovetail interface feature is located on the articular side.

11. The system of claim 10, wherein each of the first and second retention members comprises an angled inner edge which forms the first dovetail interface feature and the second dovetail interface feature, respectively.

12. The system of claim 7, wherein the implant is a fusion device.

13. A system for replacing an intervertebral disc in an intervertebral space between a first vertebral body and a second vertebral body, the system comprising:

an implant including a first end plate and a second end plate, the first and second end plates having externally facing surfaces configured to engage the first and second vertebral bodies, respectively, the first end plate configured to articulate relative to the second end plate, the first end plate including a first protruding portion defining a first pocket and the second end plate including a second protruding portion defining a second pocket, the second pocket having a different size than the first pocket, the first protruding portion and the second protruding portion extending from internally facing surfaces, opposite to the externally facing surfaces, of the respective first

32

and second end plates such that the first and second protruding portions are positioned adjacent each other with the first and second pockets positioned adjacent each other; and

an intervertebral implant inserter, the implant inserter comprising a first pivotable element, a second pivotable element, and a control member, wherein each pivotable element engages the control member;

wherein the first and second pivotable elements are pivotable between an open position and a closed position in which the first and second pivotable elements each include a shaped engagement surface and are pivoted toward each other to grip a complementarily shaped mating surface on the first and second protruding portions extending from the internally facing surfaces of the respective first and second end plates of the implant between the first and second pivotable elements, wherein the first and second pivotable elements each pivot about separate pivot axes,

wherein the pivoting of the pivotable elements both into the open position and into the closed position is controlled by actuation of the control member, and

wherein the implant inserter further comprises a keying feature wherein the keying feature comprises a protrusion formed on a distal end of the implant inserter, the keying feature positioned between and independent of the first and second pivotable elements, the keying feature shaped to control the position of the implant mounted to the implant inserter, wherein the keying feature is shaped to allow mounting of the implant on the implant inserter in only one position, wherein the keying feature includes opposing sides shaped to correspond to, and to be inserted into, and engage with both the first pocket and the second pocket defined in the respective first and second protruding portions extending from the internally facing surfaces of the respective first and second end plates of the implant.

14. The system of claim 13, wherein the separate pivot axes of the first and the second pivotable elements comprise the first pivotable element pivotable about a first axis and the second pivotable element pivotable about a second axis, wherein the first and second axes are not co-axial.

15. The system of claim 14, wherein each of the first and second pivotable elements comprises a proximal end and a distal end, wherein the first and second pivotable elements pivot about the respective proximal end thereof.

16. The system of claim 15, wherein each of the distal ends of the first and second pivotable elements comprises an engagement surface mateable with the implant to securely grip the implant.

17. The system of claim 13, wherein each of the first and second pivotable elements is L-shaped.

18. The system of claim 13, wherein the implant is removably mountable on the intervertebral implant inserter to enable insertion of the implant into the intervertebral space between a first vertebral body and a second vertebral body.

19. The system of claim 18, wherein the implant comprises a nucleus positioned between the first and second end plates.

20. The system of claim 19, wherein the first end plate comprises a first dovetail interface feature and the second end plate comprises a second dovetail interface feature, the first and second dovetail interface features shaped to complementarily mate with the first and second pivotable elements when the first and second pivotable elements are in the closed position.

21. The system of claim 18, wherein the implant is a fusion device.

33

22. The system of claim 13, wherein the control member comprises a rod having a first end and a second end; wherein the second end of the rod is coupled to the first and second pivotable elements; and

wherein the first end of the rod is actuatable to pivot the first and second pivotable elements into the open position and into the closed position.

23. The system of claim 13, wherein the rod is longitudinally displaceable between a first distal position in which the first and second pivotable elements are in the open position, and a second proximal position in which the first and second pivotable elements are in the closed position.

24. A system for replacing an intervertebral disc in an intervertebral space between a first vertebral body and a second vertebral body, the system comprising:

an implant comprising a first end plate having a first internally facing surface and an opposing first externally facing surface configured to engage the first vertebral body and a second end plate having a second internally facing surface and an opposing second externally facing surface configured to engage the second vertebral body, the first end plate configured to articulate relative to the second end plate, the first end plate including a first protruding portion extending from the first internally facing surface and the second end plate including a second protruding portion extending from the second planar internally facing surface, the first and second internally facing surfaces facing each other such that the first and second protruding portions are positioned adjacent each other, the first protruding portion defining a first recess and the second protruding portion defining a second recess, the second recess having a different size than the first recess; and

an intervertebral implant inserter, the implant inserter including a gripping mechanism and an alignment member, the gripping mechanism having first and second opposed surfaces pivotably attached to the alignment member and actuatable by a rod between open and closed positions, the first and second opposed surfaces pivotable about separate pivot axes between the open and closed positions in which the opposed surfaces are mateable with complementarily shaped mating surfaces on the first and second protruding portions extending from the internally facing surfaces of the respective first and second end plates of the implant to securely grip the implant;

the alignment member comprising a keying feature fixed to the alignment member, the keying feature positioned between and independent of the first and second opposed surfaces, the keying feature comprising a protrusion formed on the distal end of the implant inserter, the keying feature including opposing sides shaped to correspond to, and to be inserted into, and engage with both the first recess and the second recess defined in the respective first and second protruding

34

portions extending from the internally facing surfaces of the respective first and second end plates of the implant to mount the implant on the implant inserter in only one orientation.

25. The system of claim 24, wherein the alignment member further includes a first alignment side, and a second alignment side opposite the first alignment side, wherein the keying feature comprises a first key formed on the first alignment side and a second key formed on the second alignment side and larger than the first key, the first and second keys specifically sized to mate with the first and second recesses on the implant.

26. The system of claim 24, wherein the gripping mechanism further comprises a first pivotable element and a second pivotable element, the first and second pivotable elements comprising the opposed surfaces, wherein the first and second pivotable elements are pivotable between an open position, and a closed position in which the first and second pivotable elements are pivoted toward each other to grip the implant between the first and second pivotable elements.

27. The system of claim 26, wherein the first pivotable element is pivotable about a first axis and the second pivotable element is pivotable about a second axis, wherein the first and second axes are not co-axial.

28. The system of claim 26, wherein distal ends of the first and second pivotable elements comprises one of the opposed surfaces.

29. The system of claim 24, wherein the implant is removably mountable on the intervertebral implant inserter to enable insertion of the implant into the intervertebral space between a first vertebral body and a second vertebral body.

30. The system of claim 29, wherein the implant comprises a nucleus positioned between the first and second end plates.

31. The system of claim 29, wherein the implant comprises a fusion device.

32. The system of claim 13, wherein the first and second pivotable elements overlap each other when in the open position and when in the closed position.

33. The system of claim 24, wherein the alignment member further comprises a plurality of prongs extending distally from the alignment member, the prongs fixed with respect to the alignment member.

34. The system of claim 13, wherein the first and second pivotable elements pivot relative to one another in a first plane, wherein the implant inserter further comprises first and second wings which place the implant inserter in a preferred orientation relative to a sagittal plane, the first and second wings parallel to one another, and perpendicular to the first plane.

35. The system of claim 29, wherein the opposed surfaces and the keying feature provide three separate points of contact with the implant when the implant is mounted on the implant inserter.

\* \* \* \* \*