



US008834482B2

(12) **United States Patent**
Trautwein et al.

(10) **Patent No.:** **US 8,834,482 B2**
(45) **Date of Patent:** **Sep. 16, 2014**

(54) **INSTRUMENT SYSTEM FOR USE WITH AN INTERSPINOUS IMPLANT**

(75) Inventors: **Frank T. Trautwein**, Filderstadt (DE);
Ralf Riesinger, Wurmlingen (DE)

(73) Assignee: **Paradigm Spine, LLC**, New York, NY (US)

(*) Notice: Subject to any disclaimer, the term of this patent is extended or adjusted under 35 U.S.C. 154(b) by 354 days.

(21) Appl. No.: **11/790,727**

(22) Filed: **Apr. 27, 2007**

(65) **Prior Publication Data**
US 2008/0015609 A1 Jan. 17, 2008

Related U.S. Application Data
(60) Provisional application No. 60/796,256, filed on Apr. 28, 2006.

(51) **Int. Cl.**
A61B 17/70 (2006.01)
A61B 17/88 (2006.01)
(52) **U.S. Cl.**
CPC *A61B 17/8863* (2013.01); *A61B 17/7062* (2013.01)
USPC **606/99**; 606/248

(58) **Field of Classification Search**
USPC 606/86 R, 99, 86 A, 248, 249, 324, 90, 606/914
See application file for complete search history.

(56) **References Cited**
U.S. PATENT DOCUMENTS

5,011,484 A 4/1991 Beard
5,496,318 A 3/1996 Howland et al.

5,645,599 A 7/1997 Samani
5,836,948 A 11/1998 Zucherman et al.
5,860,977 A 1/1999 Zucherman et al.
5,876,404 A 3/1999 Zucherman et al.
5,951,553 A 9/1999 Betz et al.
6,048,342 A 4/2000 Zucherman et al.
6,068,630 A 5/2000 Zucherman et al.
6,074,390 A 6/2000 Zucherman et al.

(Continued)

FOREIGN PATENT DOCUMENTS

CN 1849105 A 10/2006
EP 0 322 334 6/1989

(Continued)

OTHER PUBLICATIONS

International Search Report for International Application No. PCT/US2007/067624 mailed Sep. 24, 2007.

(Continued)

Primary Examiner — Michael T Schaper
(74) *Attorney, Agent, or Firm* — MH2 Technology Law Group, LLP

(57) **ABSTRACT**
A surgical instrument system comprises surgical instruments for use with an implantable interspinous device having at least one pair of wings for securing the implantable device to a spinous process. The instrument system may include a surgical instrument for expanding or spreading the pair of wings to accommodate the spinous process. Further, a surgical instrument may be provided for crimping or compressing the pair of wings against the spinous process for secure attachment of the device to a vertebra. The surgical instruments may be configured similar to pliers and apply force to the pair of wings within a predetermined range so as to avoid damage, weakening or breakage of the pair of wings. The surgical instrument system may also include interspinous devices of differing sizes.

39 Claims, 9 Drawing Sheets

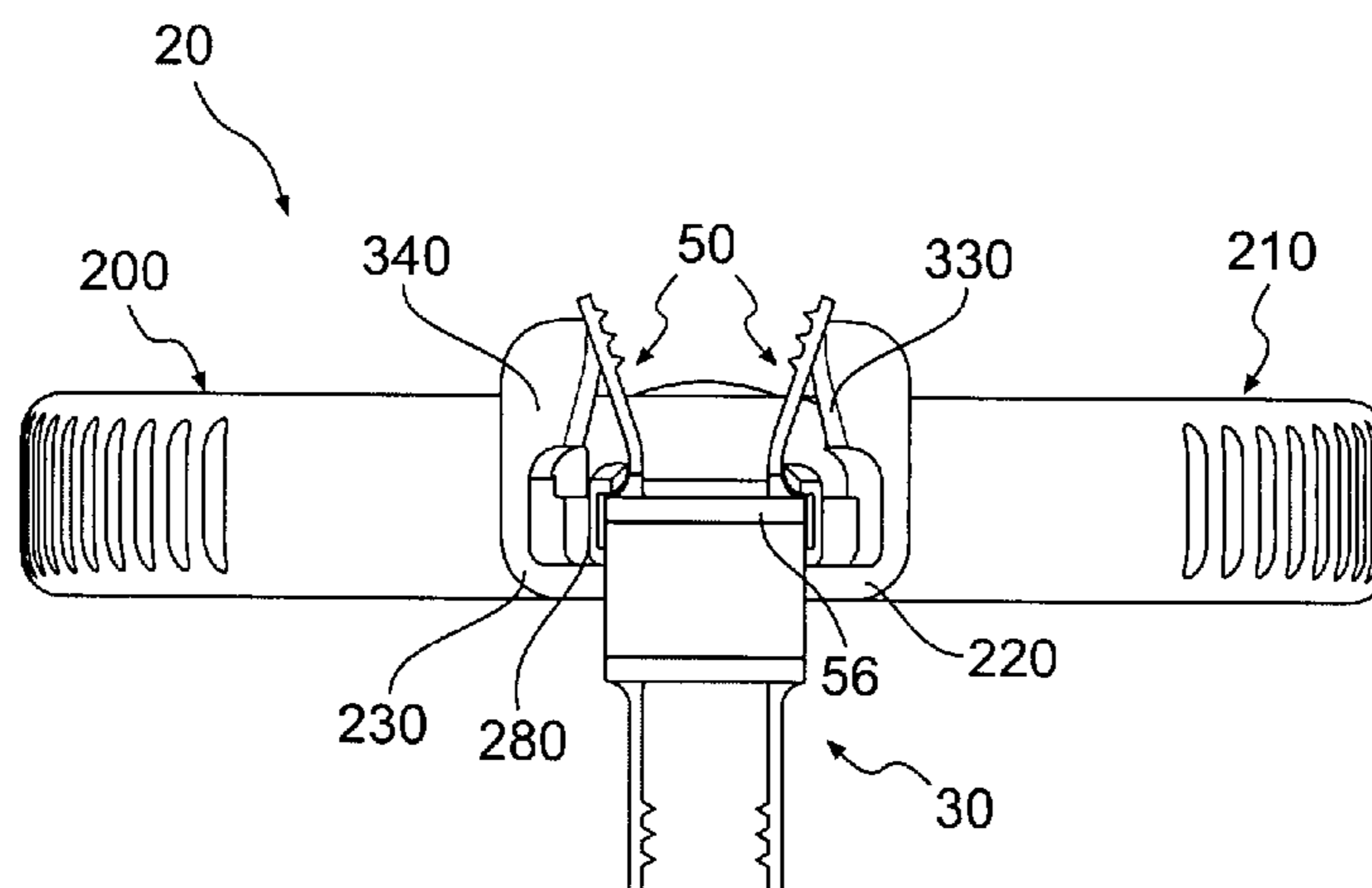

(56)

References Cited

U.S. PATENT DOCUMENTS

6,090,112 A 7/2000 Zucherman et al.
 6,149,652 A 11/2000 Zucherman et al.
 6,152,926 A 11/2000 Zucherman et al.
 6,156,038 A 12/2000 Zucherman et al.
 6,183,471 B1 2/2001 Zucherman et al.
 6,190,387 B1 2/2001 Zucherman et al.
 6,235,030 B1 5/2001 Zucherman et al.
 6,238,397 B1 5/2001 Zucherman et al.
 6,280,444 B1 8/2001 Zucherman et al.
 6,332,882 B1 12/2001 Zucherman et al.
 6,332,883 B1 12/2001 Zucherman et al.
 6,379,355 B1 4/2002 Zucherman et al.
 6,402,750 B1 6/2002 Atkinson et al.
 6,419,676 B1 7/2002 Zucherman et al.
 6,419,677 B2 7/2002 Zucherman et al.
 6,451,019 B1 9/2002 Zucherman et al.
 6,451,020 B1 9/2002 Zucherman et al.
 6,478,796 B2 11/2002 Zucherman et al.
 6,500,178 B2 12/2002 Zucherman et al.
 6,514,256 B2 2/2003 Zucherman et al.
 6,582,433 B2 6/2003 Yun
 6,626,944 B1 9/2003 Taylor
 6,652,527 B2 11/2003 Zucherman et al.
 6,652,534 B2 11/2003 Zucherman et al.
 6,695,842 B2 2/2004 Zucherman et al.
 6,699,246 B2 3/2004 Zucherman et al.
 6,699,247 B2 3/2004 Zucherman et al.
 6,712,819 B2 3/2004 Zucherman et al.
 6,733,534 B2 5/2004 Sherman
 6,761,720 B1 7/2004 Senegas
 6,796,983 B1 9/2004 Zucherman et al.
 6,902,566 B2 6/2005 Zucherman et al.
 7,090,679 B2 * 8/2006 Saint-Martin et al. 606/99
 7,252,673 B2 * 8/2007 Lim 606/99
 7,871,426 B2 * 1/2011 Chin et al. 606/248
 7,922,750 B2 * 4/2011 Trautwein et al. 606/279
 7,985,246 B2 * 7/2011 Trieu 606/279
 7,988,698 B2 * 8/2011 Rosenberg et al. 606/99
 8,419,738 B2 * 4/2013 Smisson et al. 606/86 A
 8,430,911 B2 * 4/2013 Chin et al. 606/248
 8,439,951 B2 * 5/2013 Trautwein et al. 606/249
 8,500,778 B2 * 8/2013 Jackson et al. 606/249
 2002/0072752 A1 * 6/2002 Zucherman et al. 606/99
 2003/0216736 A1 11/2003 Robinson et al.
 2004/0143332 A1 7/2004 Krueger et al.
 2004/0147936 A1 * 7/2004 Rosenberg et al. 606/99
 2004/0153071 A1 8/2004 Zucherman et al.
 2004/0153072 A1 8/2004 Bonutti
 2004/0162617 A1 8/2004 Zucherman et al.
 2004/0181282 A1 9/2004 Zucherman et al.
 2004/0199255 A1 10/2004 Mathieu et al.
 2004/0220568 A1 11/2004 Zucherman et al.

2004/0243239 A1 12/2004 Taylor
 2005/0010293 A1 1/2005 Zucherman et al.
 2005/0010298 A1 1/2005 Zucherman et al.
 2005/0015095 A1 1/2005 Keller
 2005/0055031 A1 * 3/2005 Lim 606/99
 2005/0075634 A1 4/2005 Zucherman et al.
 2005/0101955 A1 5/2005 Zucherman et al.
 2005/0102028 A1 * 5/2005 Arnin et al. 623/17.13
 2005/0143738 A1 6/2005 Zucherman et al.
 2005/0165398 A1 7/2005 Reiley et al.
 2005/0196420 A1 9/2005 Zucherman et al.
 2005/0203512 A1 9/2005 Hawkins et al.
 2005/0203624 A1 * 9/2005 Serhan et al. 623/17.11
 2005/0209603 A1 9/2005 Zucherman et al.
 2005/0216017 A1 9/2005 Fielding et al.
 2005/0228383 A1 10/2005 Zucherman et al.
 2005/0228384 A1 10/2005 Zucherman et al.
 2005/0261768 A1 * 11/2005 Trieu 623/17.11
 2006/0030860 A1 2/2006 Peterman
 2007/0162040 A1 * 7/2007 Grabowski et al. 606/90
 2007/0233076 A1 * 10/2007 Trieu 606/61
 2008/0208344 A1 * 8/2008 Kilpela et al. 623/17.16
 2008/0228225 A1 * 9/2008 Trautwein et al. 606/246
 2009/0062869 A1 * 3/2009 Claverie et al. 606/324
 2010/0087860 A1 * 4/2010 Chin et al. 606/249
 2011/0022090 A1 * 1/2011 Gordon et al. 606/249
 2011/0190819 A1 * 8/2011 Trautwein et al. 606/249
 2011/0224740 A1 * 9/2011 Smisson et al. 606/86 A
 2012/0078302 A1 * 3/2012 Reimels 606/249
 2013/0041408 A1 * 2/2013 Dinville et al. 606/249
 2014/0005723 A1 * 1/2014 Shah et al. 606/248

FOREIGN PATENT DOCUMENTS

EP 1 138 268 10/2001
 EP 1 330 987 7/2003
 FR 2 703 239 10/1994
 FR 2 717 675 9/1995
 WO WO 94/26192 11/1994
 WO WO 99/40866 8/1999
 WO WO 2004/024010 A1 3/2004
 WO WO 2004/073533 A1 9/2004
 WO WO 2004/084743 A1 10/2004
 WO WO 2005/009300 A1 2/2005
 WO WO 2005/020860 A2 3/2005
 WO WO 2005/110258 A1 11/2005

OTHER PUBLICATIONS

Written Opinion of the International Searching Authority for International Application No. PCT/US2007/067624 mailed Sep. 24, 2007.
 Taiwanese Office Action mailed Jan. 24, 2013 in corresponding Taiwanese Application No. 096115039.

* cited by examiner

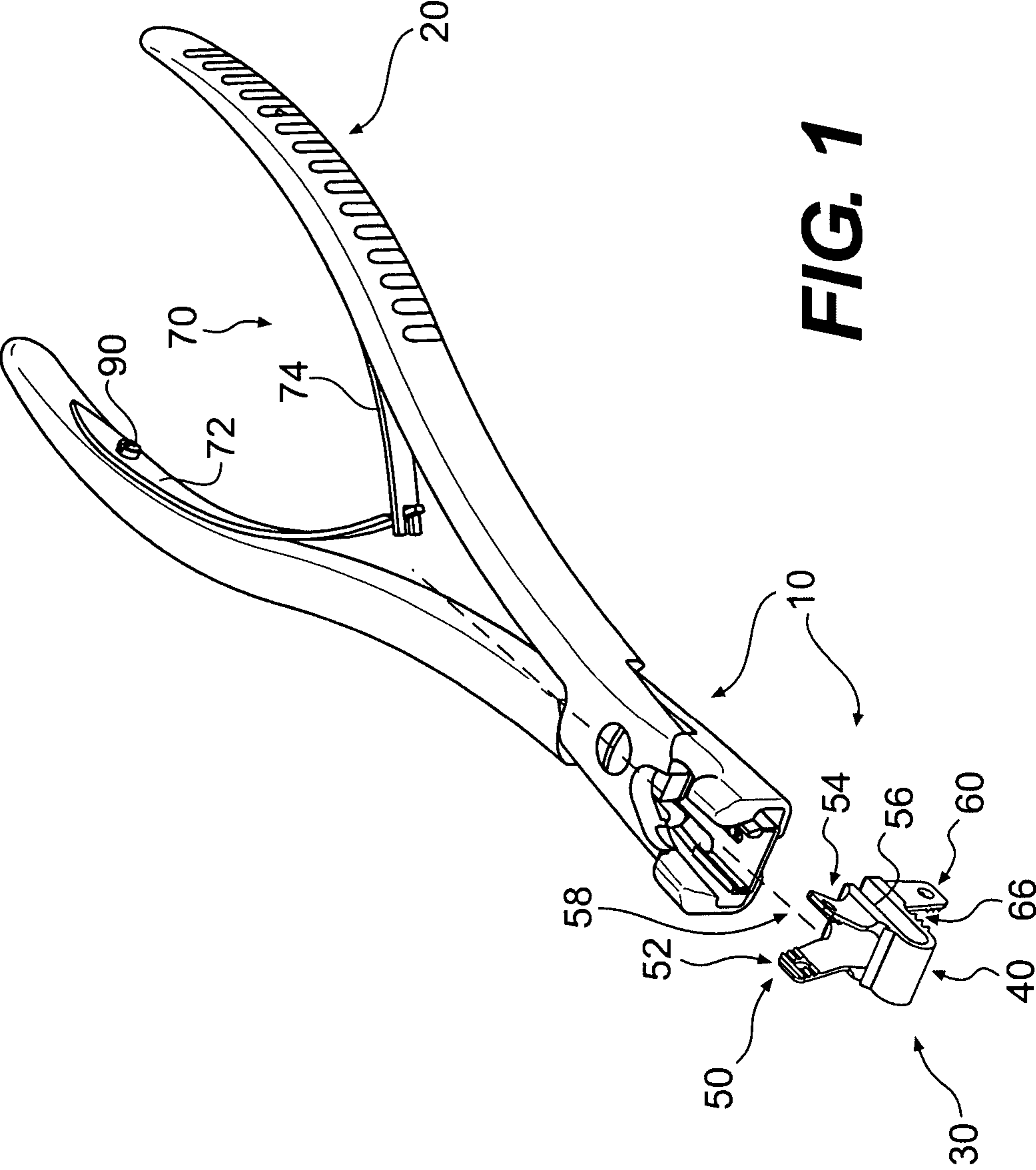

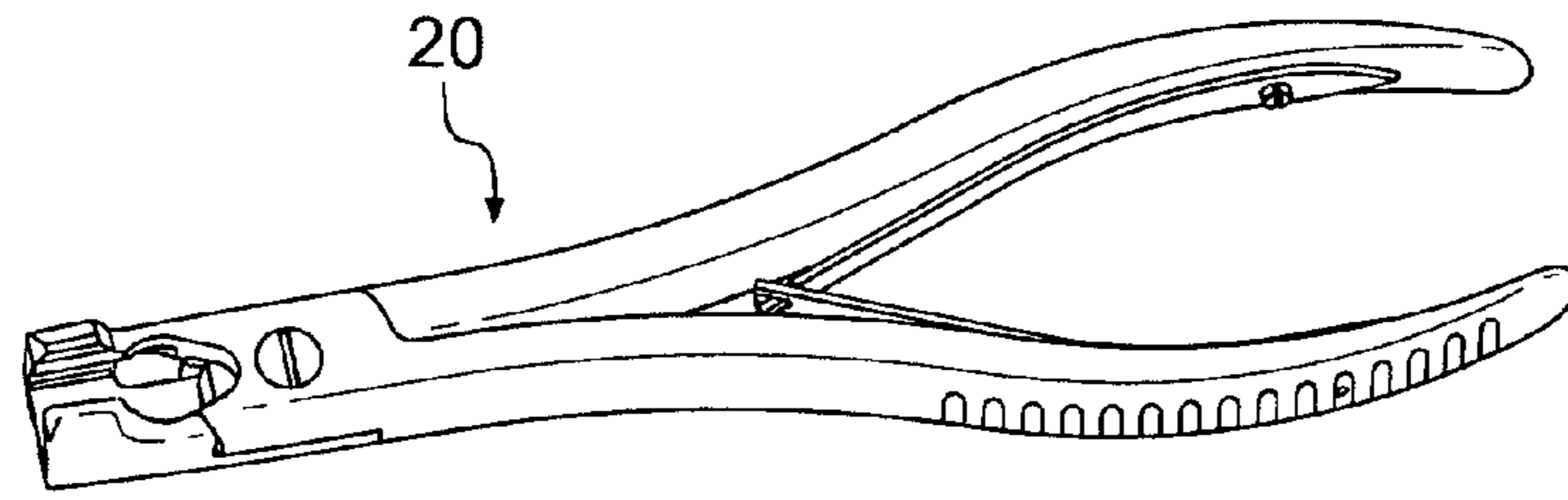

FIG. 2A

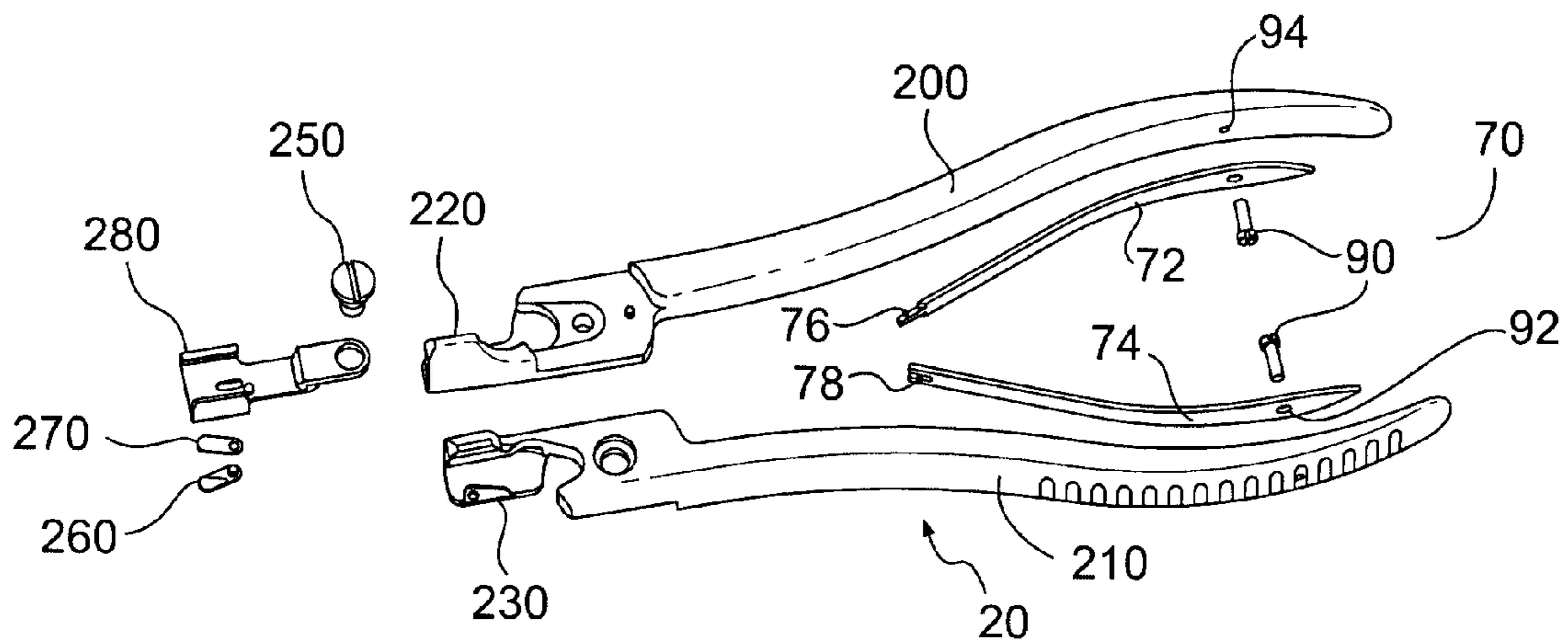

FIG. 2B

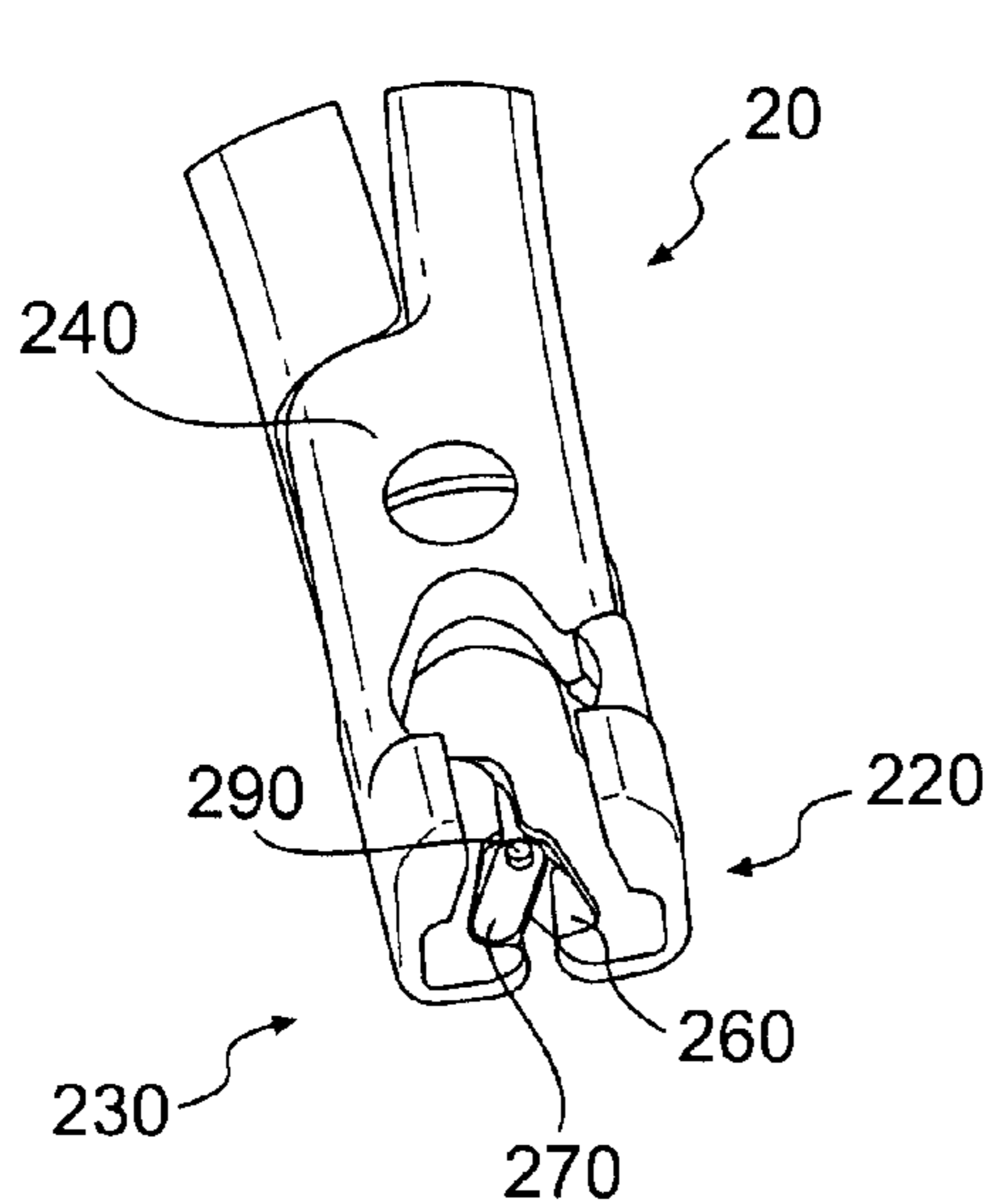

FIG. 2C

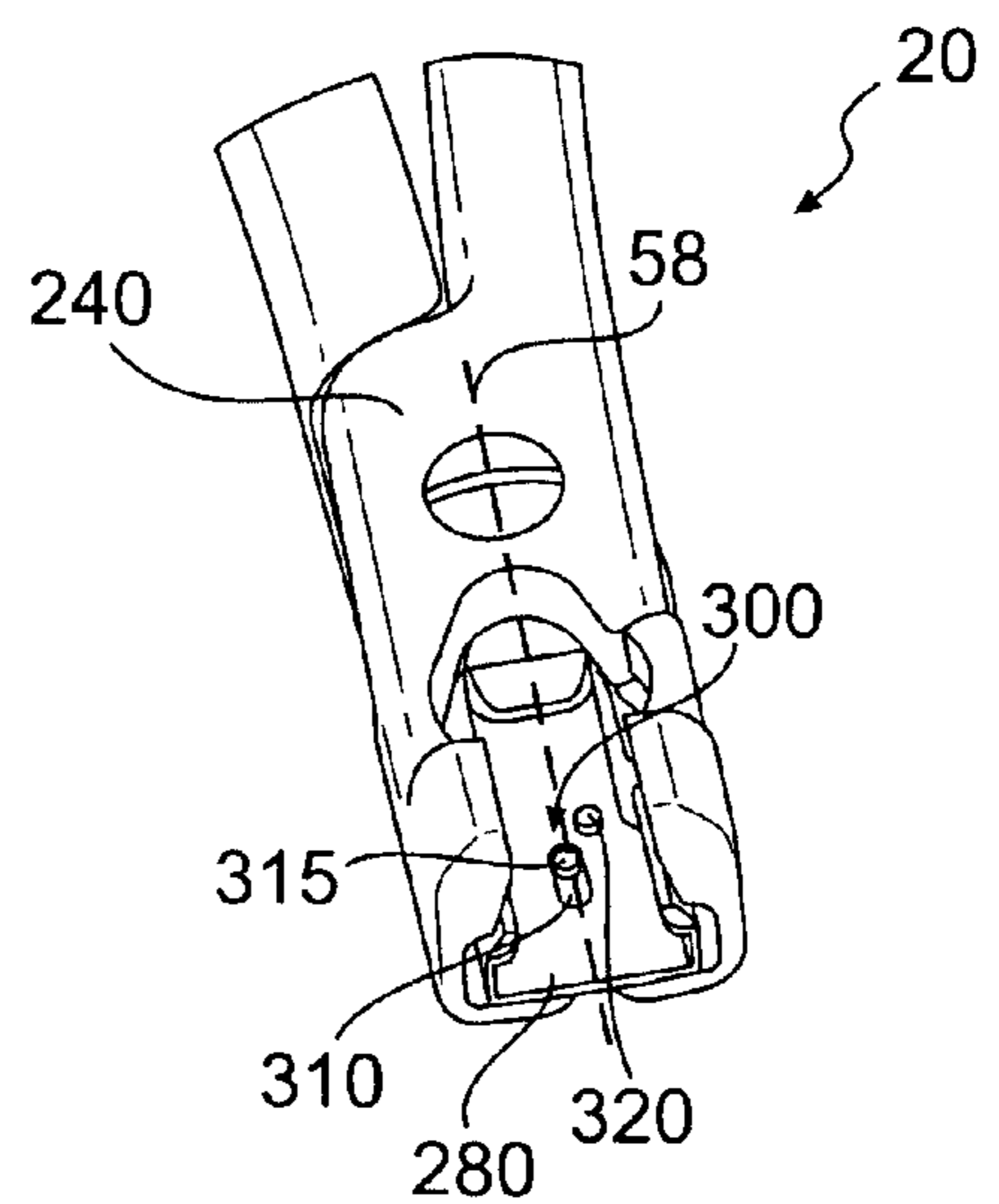

FIG. 2D

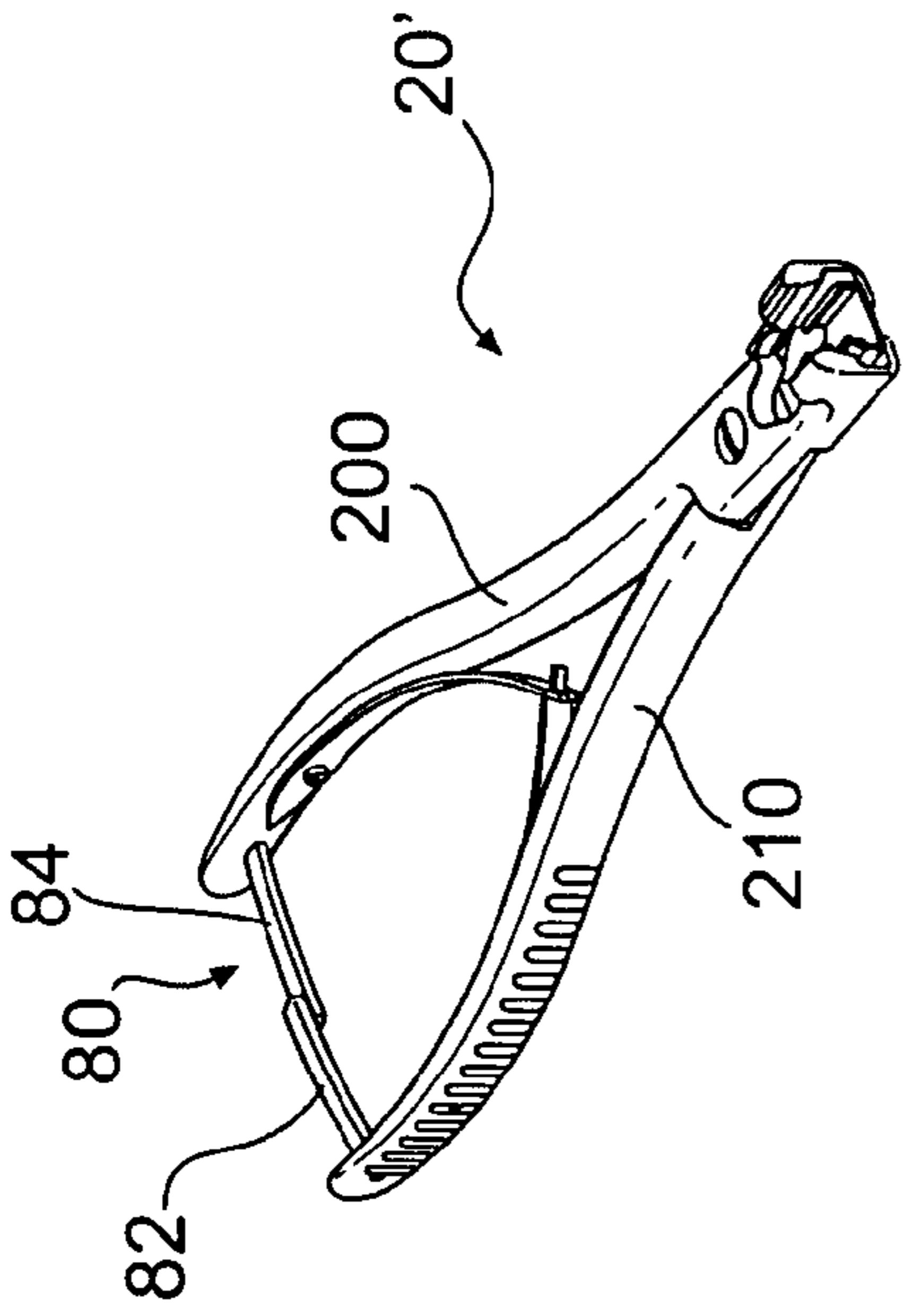

FIG. 2E

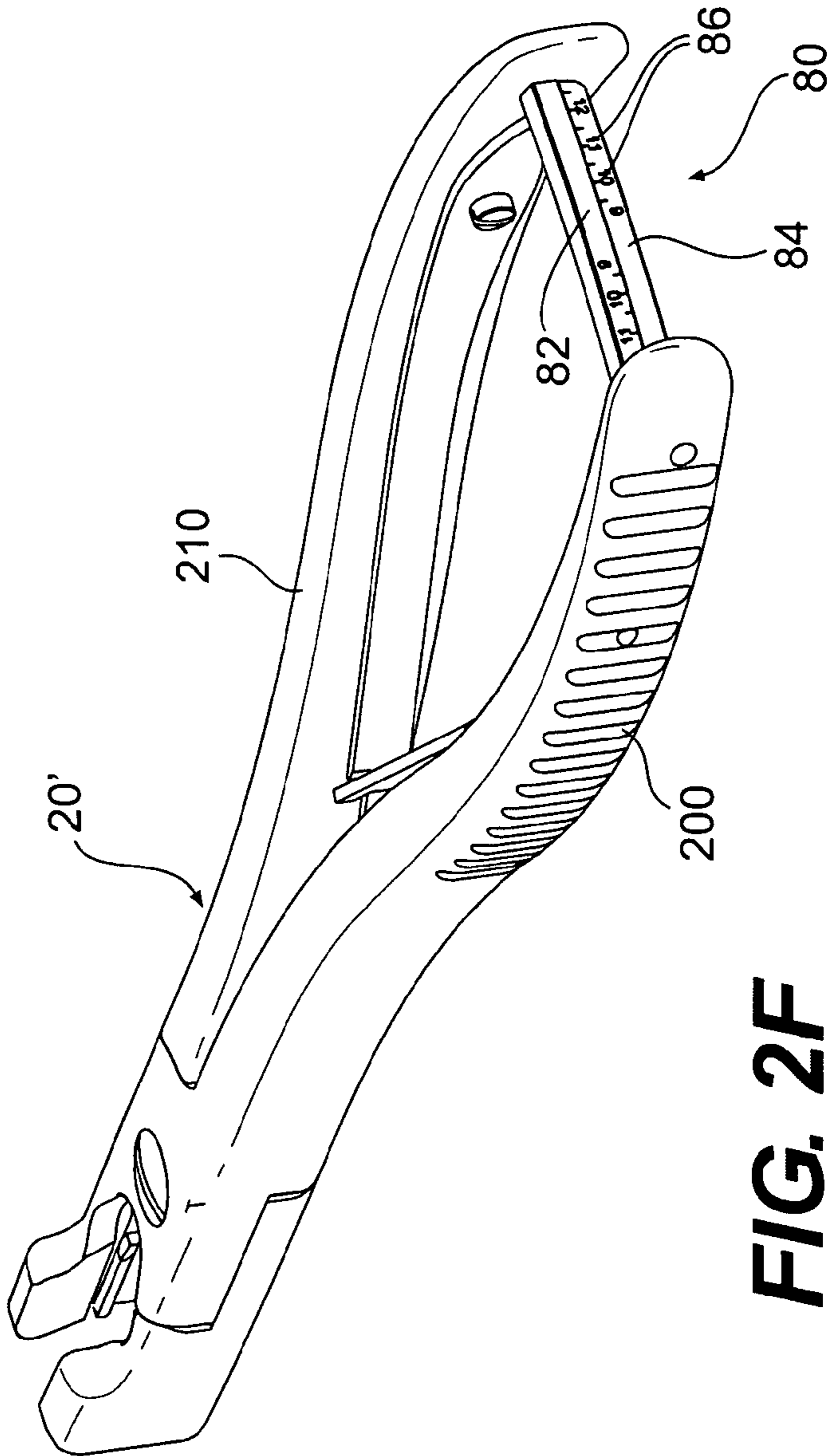

FIG. 2F

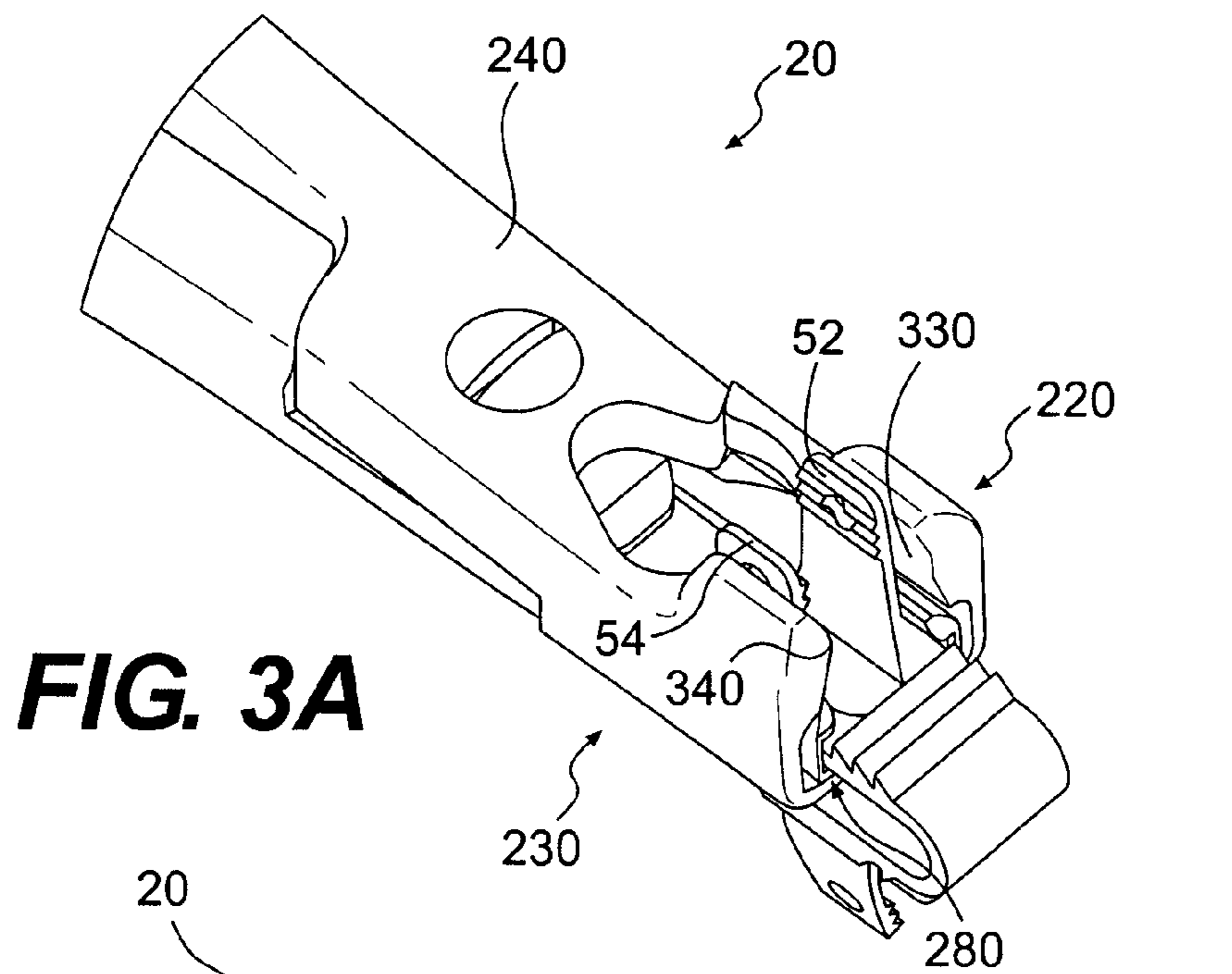

FIG. 3A

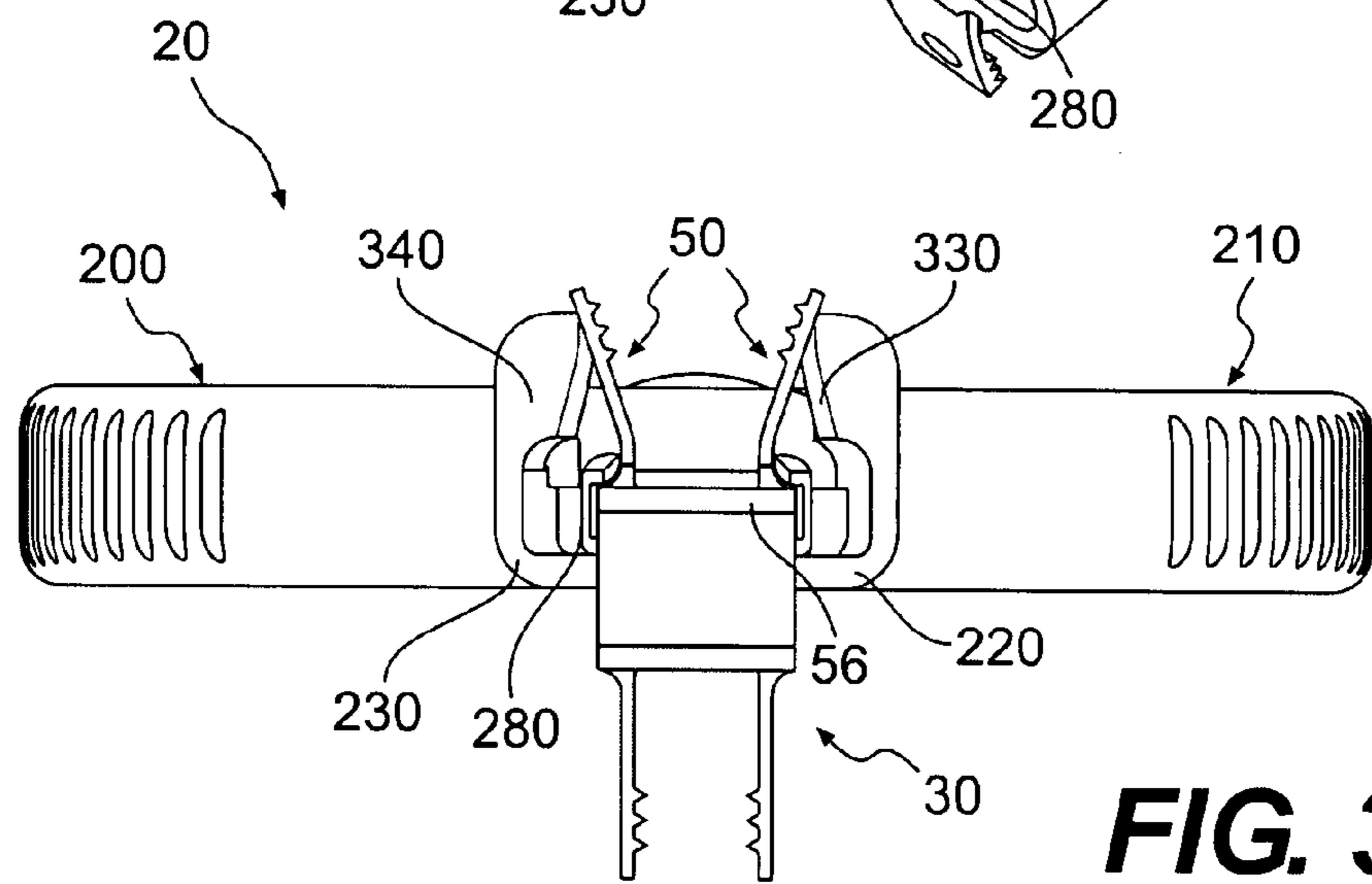

FIG. 3B

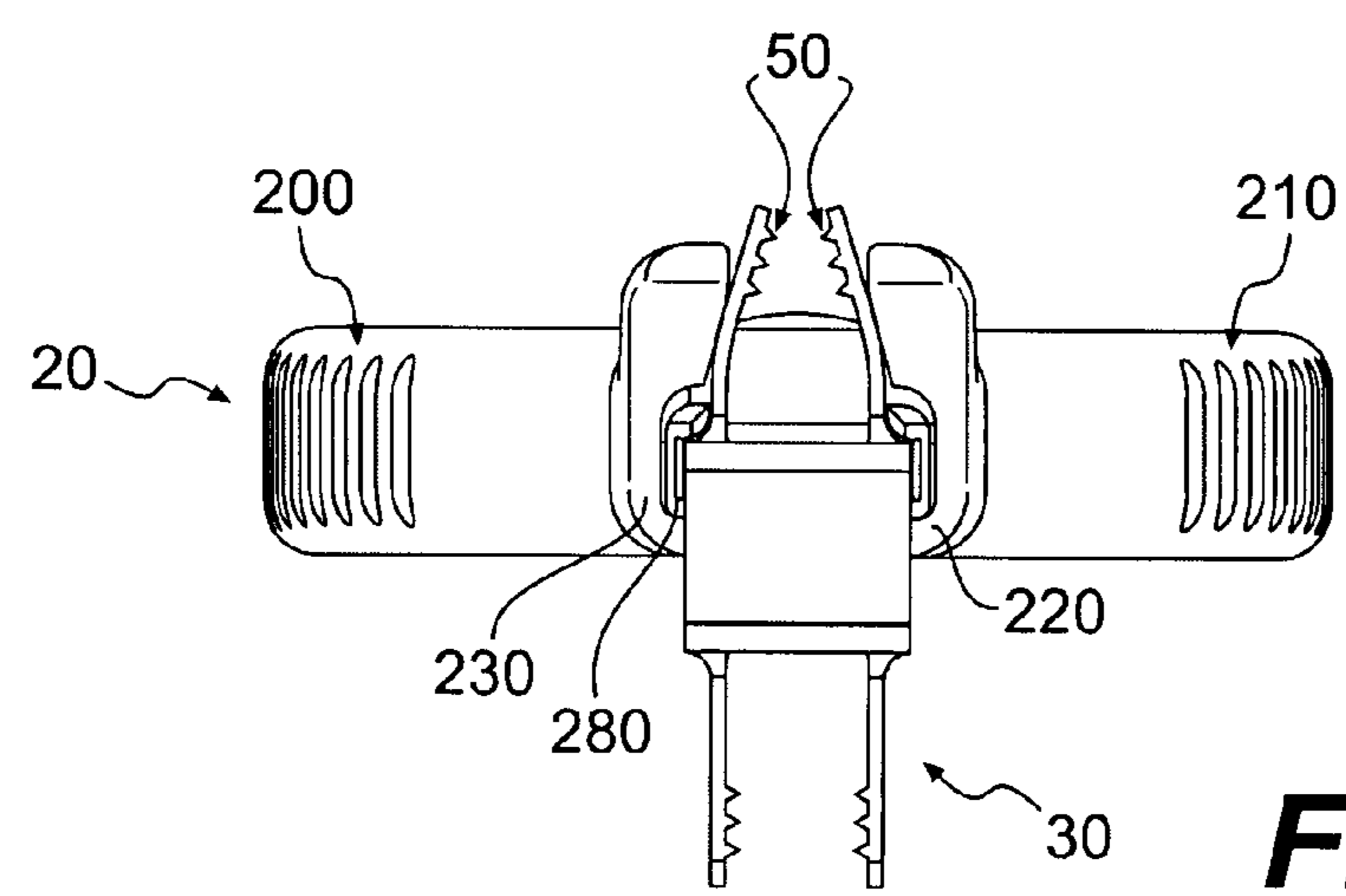

FIG. 3C

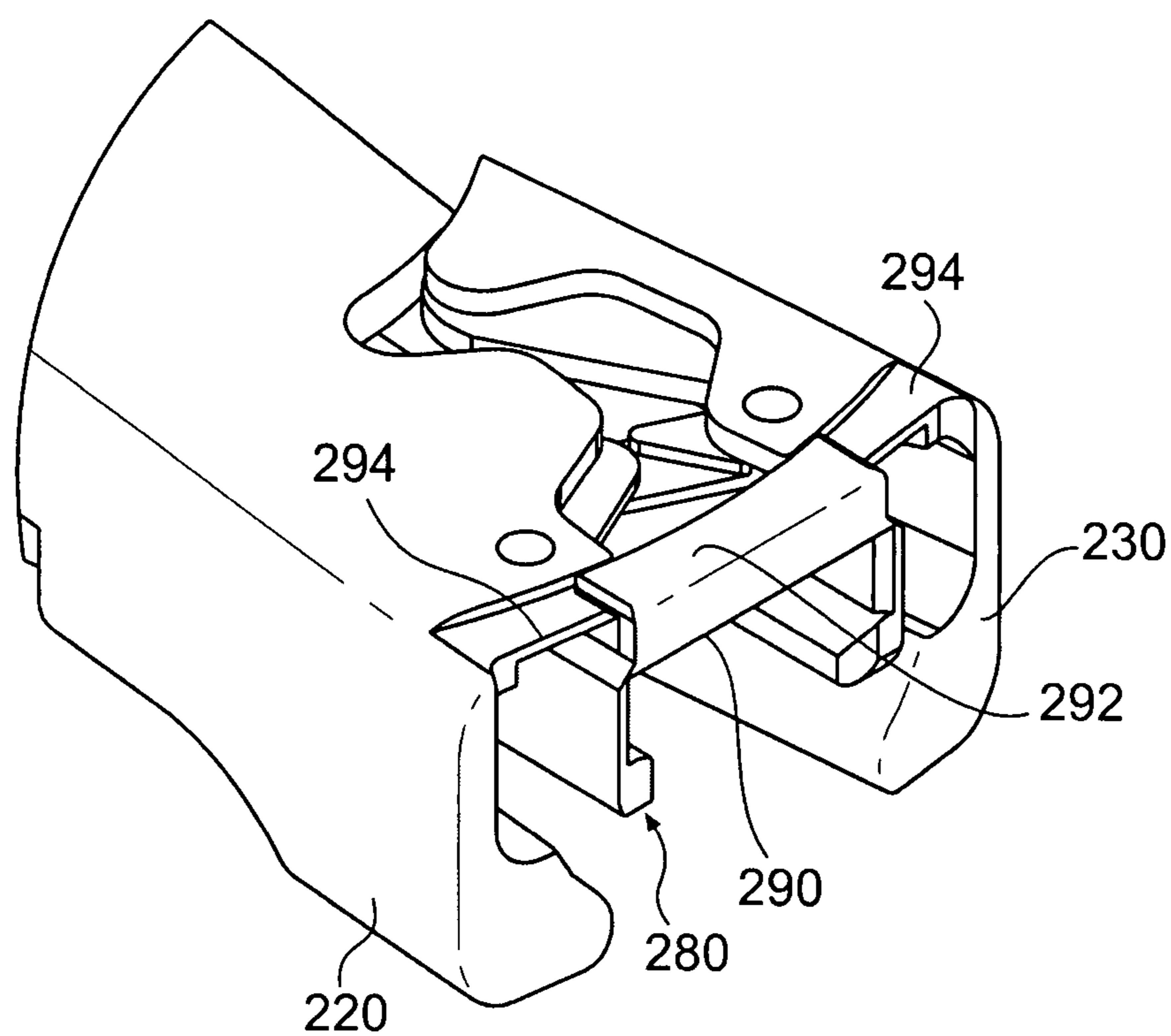

FIG. 3D

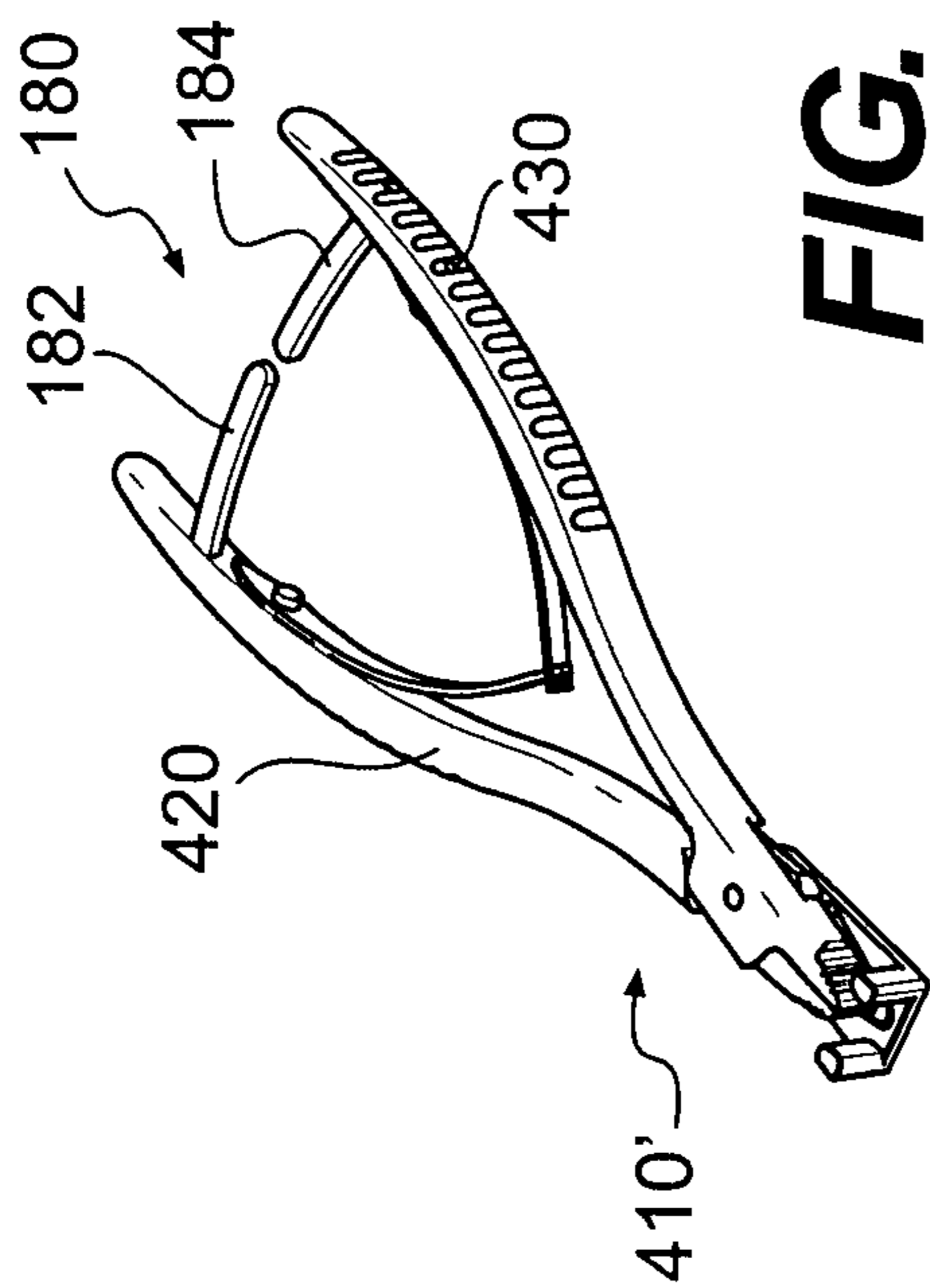

FIG. 5D

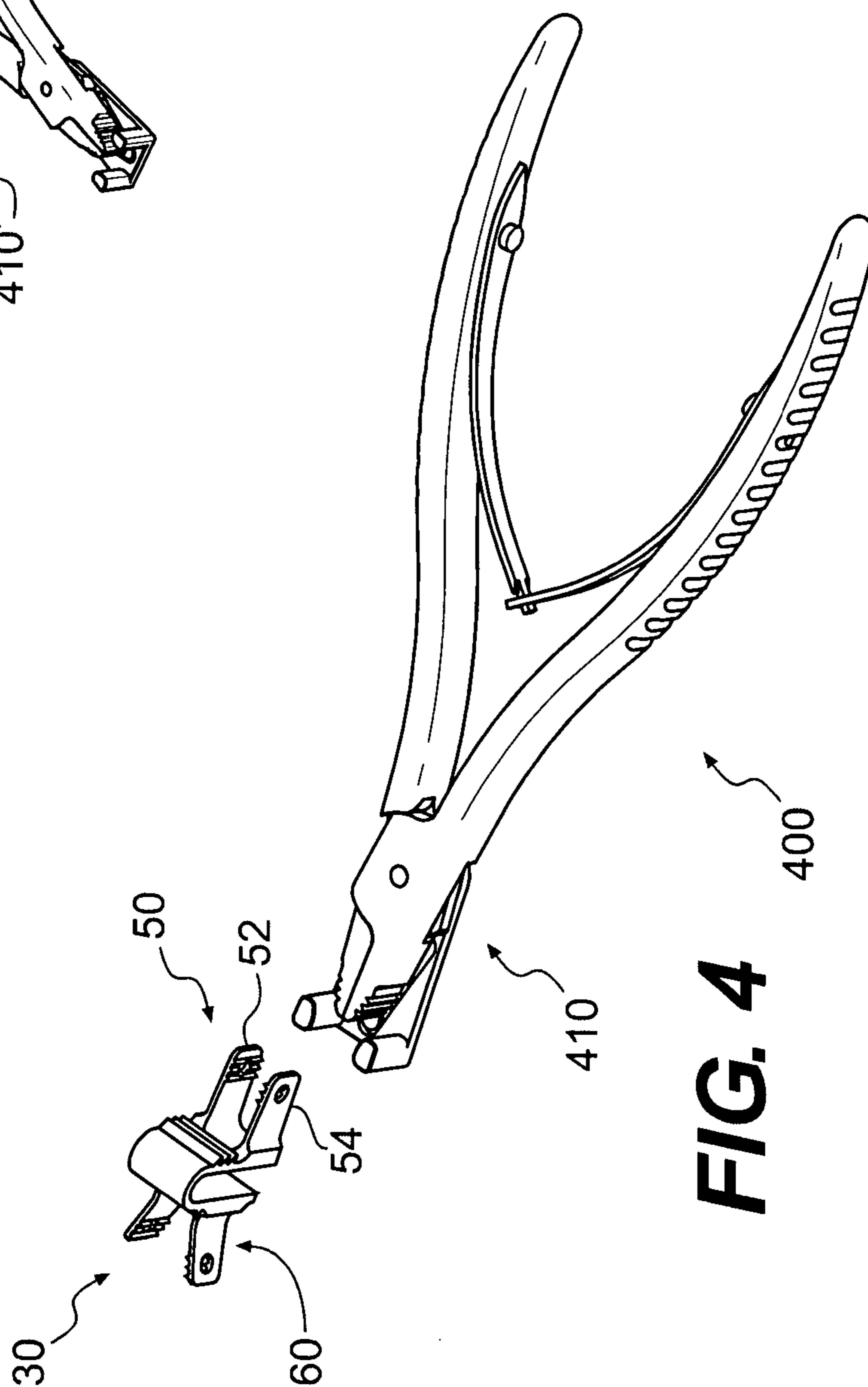
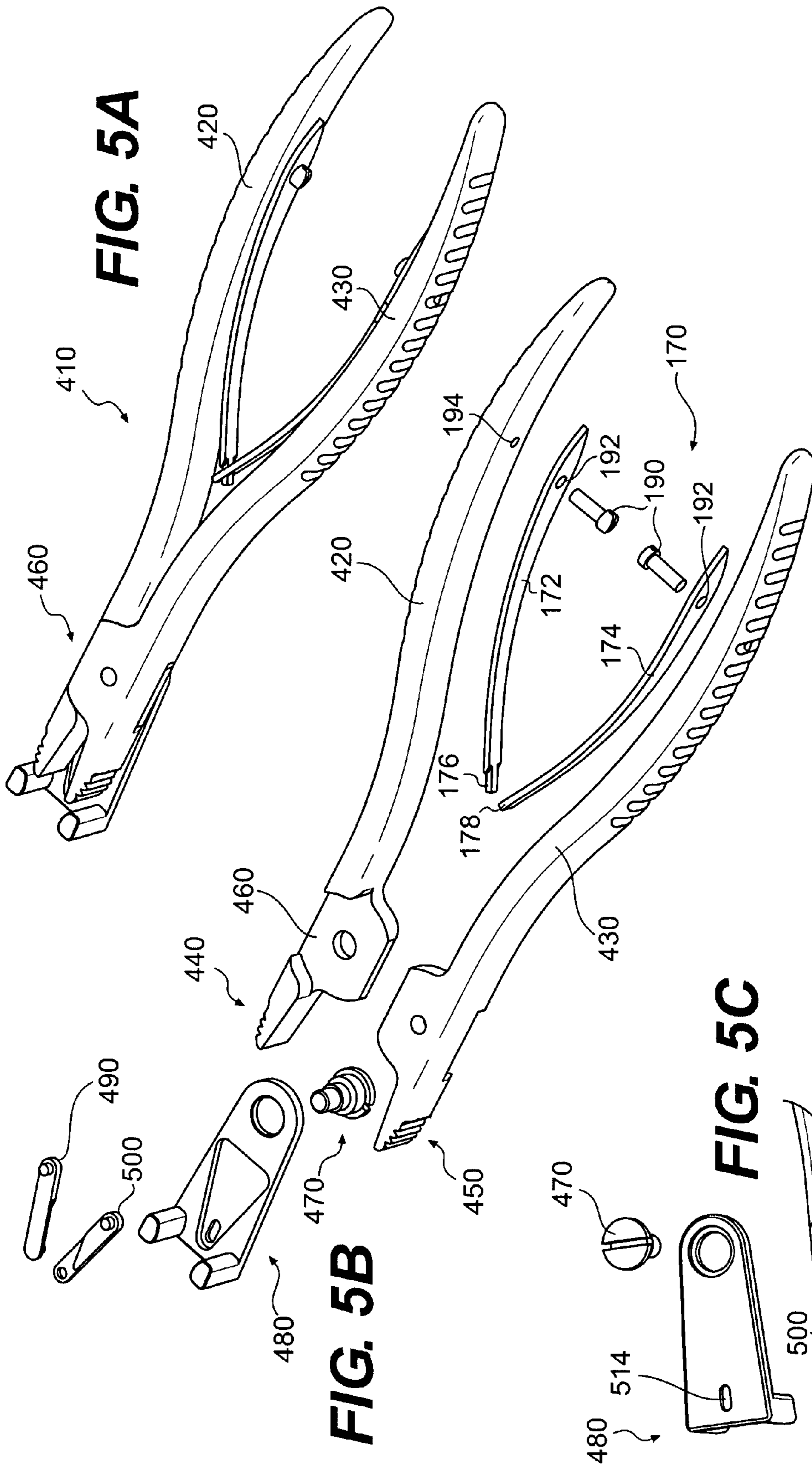

FIG. 4



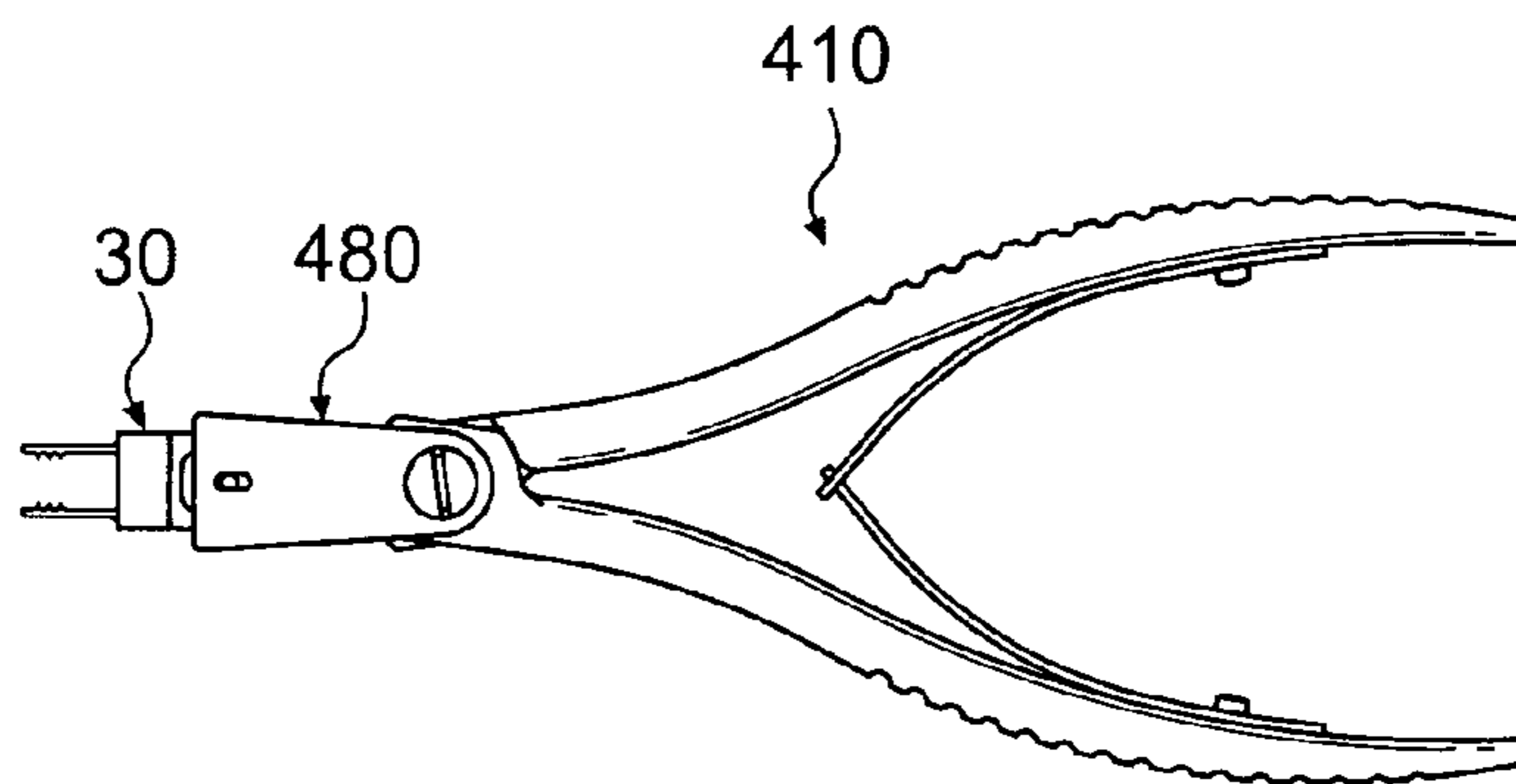

FIG. 6A

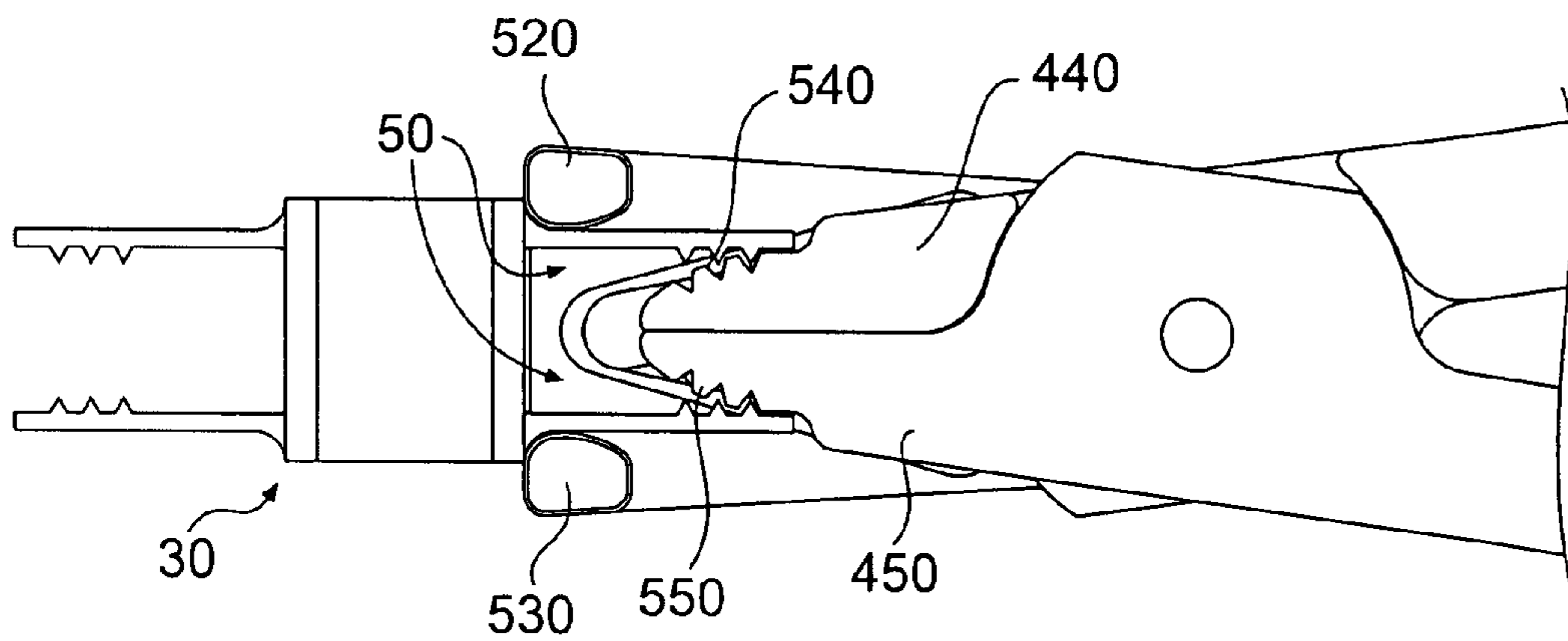

FIG. 6B

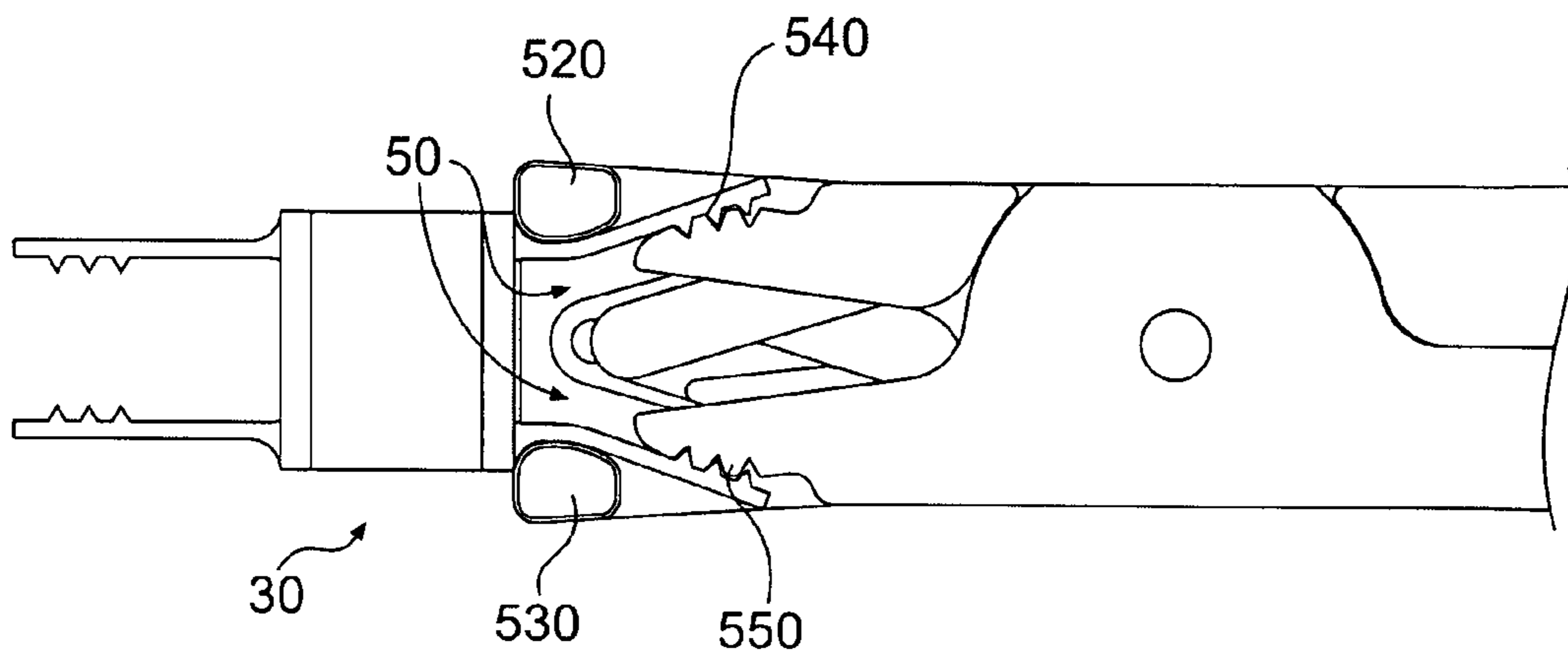
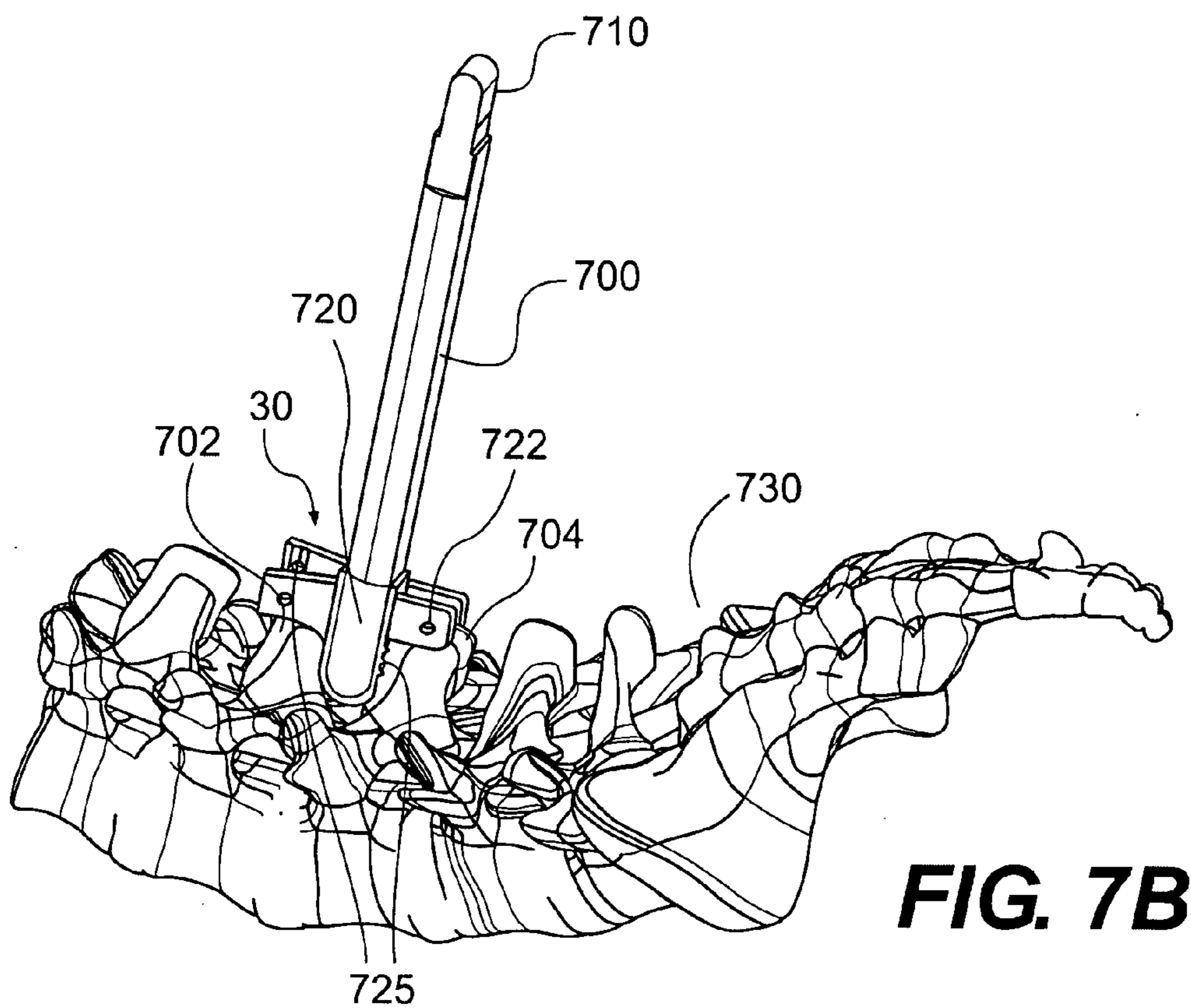
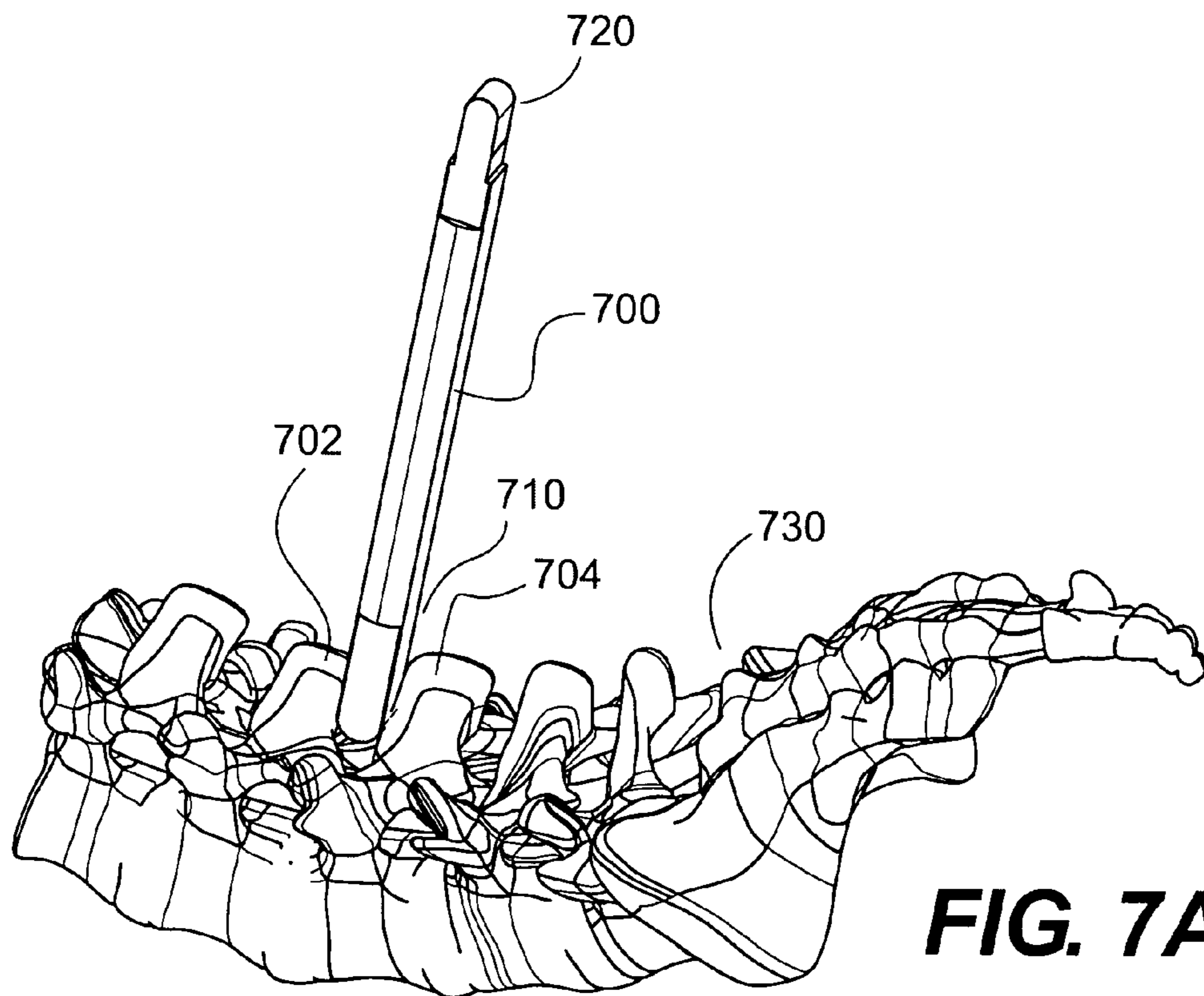

FIG. 6C



1

**INSTRUMENT SYSTEM FOR USE WITH AN
INTERSPINOUS IMPLANT**

This application claims benefit of U.S. Provisional Appli-
cation No. 60/796,256, filed Apr. 28, 2006, the entire contents
of which are incorporated herein by reference.

FIELD OF THE INVENTION

The present invention relates to devices and methods for
implanting and securing spinal implants. Specifically, the
present invention pertains to surgical instruments and instru-
ment systems for implanting interspinous devices.

BACKGROUND OF THE INVENTION

Diseases of the spine cause significant morbidity. These
diseases include abnormalities of the vertebrae, the interver-
tebral discs, the facet joints, and connective tissue around the
spine. Such abnormalities can be caused by a number of
factors, such as mechanical injury, and can include degenera-
tive disc disease, instability to the spine, vertebral misalign-
ment, and abnormal motion between adjacent vertebrae.
More severe disease may result in wear to the vertebral bony
surfaces or cause nerve compression, and may ultimately
produce severe pain. Further, these conditions are often
chronic and progressive problems.

The treatments for spinal disorders may include long-term
medical management or surgery. Medical management is
generally directed at controlling the symptoms, such as pain,
rather than correcting the underlying problems. For some
patients this may require chronic use of pain medications,
which may alter patient mental state or cause other negative
side effects.

Another treatment option is surgery, which is often highly
invasive and may significantly alter the existing spinal
anatomy and function. For example, one surgical treatment
for certain spinal conditions includes spinal fusion, whereby
two or more vertebrae may be joined using bone grafts and/or
synthetic implants. Fusion is irreversible and may signifi-
cantly alter vertebral range-of-motion. Further, current surgi-
cal procedures are often only applicable to patients in a sig-
nificantly progressed disease state.

Consequently, spinal surgeons have begun to develop more
advanced surgical procedures and spinal stabilization and/or
repair devices that are less invasive, may be reversible, and
cause a less drastic alteration in the patient's normal anatomy
and spinal function. These procedures may be used at an
earlier stage of disease progression and, in some situations,
may halt or reverse disease progression. For example, some
spinal treatment systems include interspinous devices. Inter-
spinous devices may be implanted between the spinous pro-
cesses of two vertebrae or between the spinous process of the
L5 vertebrae and the sacrum. These devices may provide
various degrees of controlled movement of the spine, while
supporting the adjacent vertebrae.

Some interspinous devices include an interspinous body
portion that is anchored to adjacent spinous processes by
wings extending from the body portion on opposite sides of
the spinous process. Further, in some cases, the wings may be
formed from a malleable material such as titanium. To facili-
tate implantation and secure attachment of the wings to the
spinous processes, it may be desirable to bend or crimp the
wings to control the distance between wings on opposite sides
of a spinous process. However, bending or crimping the
wings may be difficult using typical surgical instruments.
Further, it may be desirable to bend or crimp opposing wings

2

evenly to ensure appropriate attachment to the spinous pro-
cess and to prevent undesirable distortion of the implant
shape.

The present disclosure provides surgical instruments and
instrument sets for use with interspinous devices. The surgi-
cal instruments may facilitate bending and/or crimping of
interspinous devices to facilitate implantation and secure
attachment of the devices to spinous processes.

SUMMARY OF THE INVENTION

One aspect of the present disclosure includes a surgical
instrument. The instrument may include a first elongated
section having a first surface region configured to contact an
implantable device and a second elongated section having a
second surface region configured to contact the implantable
device. The instrument may further include a hinge region
connecting the first elongated section to the second elongated
section such that the first surface region of the first elongated
section and second surface region of the second elongated
section are mobile with respect to one another. Further, the
instrument may include a guide member operatively con-
nected to the first elongated section and second elongated
section at the hinge region such that during movement of the
first surface region of the first elongated section and second
surface region of the second elongated section the guide
member is maintained at a fixed symmetrical position with
respect to the first surface region of the first elongated section
and second surface region of the second elongated section.

A second aspect of the present disclosure includes a surgi-
cal instrument set. The instrument set may include a spinal
implant and a surgical instrument. The implant may include a
first implant body portion and at least two elongated wing
members configured to engage opposite sides of a vertebral
spinous process. The instrument may include a first elongated
section having a surface region configured to contact an
implantable device and a second elongated section having a
second surface region configured to contact the implantable
device. The instrument may further include a hinge region
connecting the first elongated section to the second elongated
section such that the first surface region of the first elongated
section and second surface region of the second elongated
section are mobile with respect to one another. Further, the
instrument may include a guide member operatively con-
nected to the first elongated section and second elongated
section at the hinge region such that during movement of the
first surface region of the first elongated section and second
surface region of the second elongated section the guide
member is maintained at a fixed symmetrical position with
respect to the first surface region of the first elongated section
and second surface region of the second elongated section.

A third aspect of the present disclosure includes a method
of securing an implant adjacent a spinous process. The
method may include selecting an implant having a first body
portion and at least two elongated wing members configured
to engage opposite sides of a vertebral spinous process. The
method may further include positioning the first body portion
adjacent a first spinous process and substantially evenly dis-
placing each wing member in a first direction relative to a
center point between the two elongated wing members to
move the two elongated wing members toward one another to
secure the elongated wing members on opposite sides of a
spinous process.

A fourth aspect of the present disclosure includes a surgical
instrument. The instrument may comprise a first surface con-
figured to contact a portion of an implantable device and a
second surface configured to contact a portion of an implant-

able device. The instrument further includes a first handle portion connecting the first surface and configured to translate a force to the first surface and a second handle portion connected to the second surface and configured to translate a force to the second surface. In addition, the device includes a guide member configured to center and hold the implantable device relative to the surgical instrument in a manner that permits the first and second surfaces to substantially evenly displace the first and second portions of the implant as the first and second surfaces contact the implantable device.

It is to be understood that both the foregoing general description and the following detailed description are exemplary and explanatory only, and are not restrictive of the invention, as claimed.

The accompanying drawings, which are incorporated in and constitute a part of this specification, illustrate several embodiments of the invention and together with the description, serve to explain the principles of the invention.

Additional objects and advantages of the invention will be set forth in part in the description that follows or may be learned by practice of the invention. The objects and advantages of the invention will be realized and attained by means of the elements and combinations particularly pointed out in the appended claims.

BRIEF DESCRIPTION OF THE DRAWINGS

FIG. 1 illustrates a portion of a surgical kit, including a surgical instrument and an implant, according to an exemplary disclosed embodiment.

FIG. 2A illustrates a perspective view of the surgical instrument of the surgical kit of FIG. 1, according to an exemplary disclosed embodiment.

FIG. 2B illustrates an exploded view of the surgical instrument of FIG. 2A.

FIG. 2C illustrates a perspective view of an end region of the surgical instrument of FIG. 2A without a guide member, according to an exemplary disclosed embodiment.

FIG. 2D illustrates a perspective view of an end region of the surgical instrument of FIG. 2A with a guide member, according to an exemplary disclosed embodiment.

FIG. 2E illustrates a perspective view of an alternative configuration of the surgical instrument of FIG. 2A, according to another exemplary disclosed embodiment.

FIG. 2F illustrates another perspective view of the surgical instrument of FIG. 2E.

FIG. 3A illustrates a perspective view of the surgical instrument of FIG. 2A engaging an interspinous implant.

FIG. 3B illustrates an end view of the surgical instrument of FIG. 2A engaging an interspinous implant before compression of the implant's wings.

FIG. 3C illustrates an end view of the surgical instrument of FIG. 2A engaging an interspinous implant after compression of the implant's wings.

FIG. 3D illustrates a perspective view of the underside of the end region of the surgical instrument of FIG. 3A, according to an exemplary embodiment.

FIG. 4 illustrates another portion of a surgical kit, including a surgical instrument and an implant, according to an exemplary disclosed embodiment.

FIG. 5D illustrates a perspective view of another surgical instrument, according to another exemplary disclosed embodiment.

FIG. 5A illustrates another perspective view of the surgical instrument of FIG. 4, according to an exemplary disclosed embodiment.

FIG. 5B illustrates an exploded view of the surgical instrument of FIG. 5A, according to an exemplary disclosed embodiment.

FIG. 5C illustrates an exploded view of an end region of the surgical instrument of FIG. 5A, according to an exemplary disclosed embodiment.

FIG. 6A illustrates a top view of the surgical instrument of FIG. 5A engaging an interspinous implant.

FIG. 6B illustrates an enlarged top view of a front end of the surgical instrument of FIG. 6A engaging an interspinous implant before expansion of the implant's wings.

FIG. 6C illustrates an enlarged view of the surgical instrument of FIG. 6A engaging an interspinous implant after expansion of the implant's wings.

FIG. 7A illustrates a portion of a surgical kit, including a sizing and insertion implement, according to an exemplary disclosed embodiment.

FIG. 7B illustrates the implement of FIG. 7A engaging an interspinous implant, according to an exemplary disclosed embodiment.

DESCRIPTION OF EXEMPLARY EMBODIMENTS

Reference will now be made in detail to the present exemplary embodiments of the invention, examples of which are illustrated in the accompanying drawings. Whenever possible, the same reference numbers will be used through out the drawings to refer to the same or like parts.

Implantable interspinous devices **30** can be used to treat a variety of surgical conditions, including, for example, degenerative disc disease and spinal stenosis. These devices **30** generally include an interspinous body portion **40** that is placed between the spinous processes of adjacent vertebrae, or the L5 spinous process and the sacrum. The devices **30** further include structures that allow the interspinous body to be secured between the spinous processes. For example, some devices can include a pair of wings **50**, **60** that extend on opposite sides of a spinous process.

The interspinous body portion of an interspinous implantable device may be provided in a variety of different sizes to facilitate implantation into interspinous spaces (the space between two adjacent interspinous processes) of different sizes. However, the wing portions of such interspinous devices may need to be adjusted to allow implantation around a selected spinous process, and to provide sufficient compressive force to the spinous process to secure the implant in place.

To facilitate adjustment of the space between the wings and the resultant "fit" of the device relative to the spinous processes, surgical instruments to bend or expand the wings during insertion of the device into the interspinous space and to crimp or compress the wings after implantation of the device are provided. These surgical instruments may be sold separately or sold in a kit with one or more implants. One or both of the surgical instruments may be provided in the kit. The surgical instruments may be used in separate procedures or together in the same procedure. For example, it may be necessary only to crimp or compress the wings during the surgical procedure and unnecessary to expand or spread the wings prior to insertion. Alternatively, it may be necessary to spread or expand the wings prior to insertion and unnecessary to subsequently compress or crimp the wings after insertion of the interspinous implant.

FIG. 1 illustrates a portion of a surgical kit or system **10**, including a surgical instrument **20** and an implantable device **30**, according to an exemplary disclosed embodiment. As

5

shown, implantable device **30** comprises an interspinous implant. Implantable device **30** may include a U-shaped body portion **40** configured to be positioned below a spinous process (not shown). Implantable device **30** may further include at least one pair of wings **50**, including a first wing **52** and second wing **54**. Pair of wings **50** may extend from an upper surface **56** of body portion **40** and may be configured to engage a spinous process when implanted. Further, in some embodiments, implantable device **30** may include a second pair of wings **60** that may extend from a lower surface **66** of body portion **40** and may be configured to engage a second spinous process (not shown). Exemplary implants suitable for use with the present surgical instrument **20** and included with the instrument set **10** are described in detail in U.S. Pat. No. 5,645,599 to Jacques Samani, which is titled, "Interspinal Vertebral Implant," and U.S. Provisional Patent Application No. 60/868,080 filed Nov. 30, 2006 and entitled "Interspinous Vertebral Stabilization System" both of which are hereby incorporated by reference in their entirety.

In some embodiments, the surgical instruments of the present disclosure will facilitate symmetric adjustment of the wings **52**, **54** of implantable interspinous devices **30**. For example, to ensure appropriate placement and securement of a device **30**, it may be desirable to bend the wings **52**, **54** symmetrically to center the spinous process between the wings and/or provide an appropriate compressive force to the spinous process. However, due to variations in design tolerances and production, the thicknesses of the wings **52**, **54** may vary slightly from one another, which could affect the ease with which they bend or the amount of bending achieved, and thus produce asymmetric bending on opposing wings. The surgical instruments of the present disclosure can facilitate symmetric, bending by ensuring symmetric displacement of the wings to compress the wings **52**, **54** onto a spinous process or to expand the wings **52**, **54** before implantation. This symmetric displacement of the wings can be accomplished even with variations in wing thickness or material properties.

Surgical instrument **20** may be used to facilitate secure attachment of implantable device **30** to bone. As described below, instrument **20** may be used to bend or compress the pair of wings **50** or the pair of wings **60**, thereby crimping the wings of a pair of wings **50**, **60** to a spinous process therebetween. Further, although FIG. **1** illustrates an exemplary embodiment of implantable device **30** that may be included in surgical system **10**, it is understood that any suitable implantable device may be selected wherein implantable device **30** includes at least one pair of wings **50**, **60** that may be compressed by surgical instrument **20** and configured to secure implantable device **30** to at least one spinous process. Additionally, surgical instrument **20** may be adapted to be used to crimp extending portions of implants intended to be used in areas other than the spine. For example, some interspinous implants may be adapted for placement between the L5 spinous process and the sacrum. Exemplary interspinous implants that may be used for treatment of the lumbosacral region are described in detail in U.S. Patent Publication No. 2006/0241601A1, to Frank Trautwein et al., which is titled, "Interspinous Vertebral and Lumbosacral Stabilization Devices and Methods of Use," and which is hereby incorporated by reference in its entirety.

In some embodiments, the surgical instruments of the present disclosure will facilitate symmetric adjustment of the wings **52**, **54** of implantable interspinous devices **30**. For example, to ensure appropriate placement and securement of a device **30**, it may be desirable to bend the wings **52**, **54** symmetrically to center the spinous process between the wings and/or provide an appropriate compressive force to the

6

spinous process. However, due to small variations in design tolerances and production, the wings **52**, **54** may have small variations in thickness which could affect the ease with which they bend, and produce asymmetric bending on opposing wings. The surgical instruments of the present disclosure can facilitate symmetric bending by ensuring symmetric displacement of the wings to compress the wings **52**, **54** onto a spinous process or to expand the wings **52**, **54** before implantation. This symmetric displacement of the wings can be accomplished even with variations in wing thickness or material properties.

FIG. **2A** illustrates a perspective view of surgical instrument **20** of FIG. **1**, according to an exemplary disclosed embodiment, and FIG. **2B** illustrates an exploded view of surgical instrument **20** of FIG. **2A**. As shown in FIGS. **2A** and **2B**, instrument **20** includes a first handle portion **200** and a second handle portion **210**. First handle portion **200** may be connected with a first elongated section **220**, and second handle portion **210** may be connected with a second elongated section **230**. First and second handle portions **200**, **210**, may be integrally formed with first and second elongated sections **220**, **230**, respectively. Alternatively, the elements may be separately formed and then connected. Further, first handle portion **200** and second handle portion **210** may be operatively connected to one another at a hinge region **240**, as indicated in FIGS. **2C** and **2D**. Hinge region **240** may include a hinge connector **250**, as shown in FIG. **2B**. Hinge connector **250** may include any suitable connector type, such as a screw, a bolt, a pin, or other suitable connector.

A leaf spring mechanism **70** may also be provided between first handle portion **200** and second handle portion **210** to provide a biased, resistance force between first and second handle portions **200**, **210**. Leaf spring mechanism **70** may comprise two leaf springs **72**, **74**. One of the leaf springs **72** may terminate at a male portion **76**, while the other leaf spring **74** may terminate at a female portion **78**, as shown. Leaf springs **72**, **74** may rest against one another in a freely movable, hinged configuration. This hinged configuration enables leaf springs **72**, **74** to freely pivot with respect to one another. Each of leaf springs **72**, **74** may be attached to a respective handle portion **200**, **210** with a fastener **90**. As shown in detail in FIG. **2B**, leaf springs **72**, **74** may attach to first and second handle portions **200**, **210**, respectively, by securing fasteners **90** through holes **92** on leaf springs **72**, **74**, and into holes **94** of first and second handle portions **200**, **210**. Fastener **90** may comprise any suitable connector such as, for example, a screw, a bolt, or a pin, as is commonly used in the art.

A surgeon may grasp surgical instrument **20** by first handle portion **200** and second handle portion **210**, and by increasing or decreasing the distance between first handle portion **200** and second handle portion **210**, may correspondingly increase or decrease the distance between first elongated section **220** and second elongated section **230**. In some embodiments, as the distance between first handle portion **200** and second handle portion **210** is increased, the distance between first elongated section **220** and second elongated section **230** will increase. Conversely, as the distance between first handle portion **200** and second handle portion **210** is decreased, the distance between first elongated section **220** and second elongated section **230** will decrease.

Hinge region **240** may include at least two connector pieces **260**, **270** and a guide member **280**. FIG. **2C** illustrates a perspective view of an end region of surgical instrument **20** of FIG. **2A** without a guide member. As shown, first connector piece **260** may form a rotatably mobile connection with first elongated section **220**, and second connector piece **270** may form a rotatably mobile connection with second elongated

section 230. Connector pieces 260, 270 may further form a common rotatably mobile connection 290 with one another. Further, common connection 290 may form a second common connection 300 with guide member 280, as shown in FIG. 2D. Connector pieces 260, 270 may secure guide member 280 in a fixed position relative to first elongated section 220 and second elongated section 230 during movement of first elongated section 220 and second elongated section 230 about hinge region 240.

Guide member 280 and connector pieces 260, 270 may facilitate symmetric displacement of wings 52, 54. For example, as noted previously, due to design tolerances and production variables, the thicknesses and material properties of wings 52, 54 may vary slightly. Therefore, if equal bending forces are applied to each wing 52, 54 the displacement or degree of bending achieved for each wing 52, 54 may vary, thereby producing asymmetric engagement with a spinous process. The guide member 280 and connector pieces 260, 270 provide symmetric displacement of wings 52, 54 even when the dimensions and/or material properties of wings 52, 54 are different.

In some embodiments, the connection between guide member 280 and connector pieces 260, 270 may include a slidable connection. For example, as shown in FIG. 2D, guide member 280 may include a groove 310 in which a protrusion 315 from one connector piece 260, 270 rests. In some embodiments, groove 310 may include an elongated groove aligned with a central longitudinal axis 58 of surgical instrument 20, as shown in FIG. 2D.

FIG. 2E illustrates a perspective view of a surgical instrument 20', according to another exemplary disclosed embodiment. Surgical instrument 20' is identical to surgical instrument 20, but with an additional visual gauge element 80. As shown in greater detail in FIG. 2F, the gauge element 80 comprises two arms 82, 84, each arm being attached to a handle region 200, 210, respectively, of surgical instrument 20'. The free ends of arms 82, 84 are configured to slide against one another when the surgical instrument 20' is engaged. Marks 86 on arms 82, 84 are aligned as the surgical instrument 20' is compressed or squeezed together, thereby indicating to the user the distance between the pair of wings 50, 60. Marks 86 may include numerals, scores, color-coded bars, or other visual indicators which are intended to line up on arms 82, 84. Thus, gauge element 80 helps to make surgical instrument 20' function much like a caliper. In this manner, surgical instrument 20' may also serve as a measuring device, allowing the user to measure the distance between the pair of wings 50, 60 prior to or after implantation.

As noted previously, surgical instrument 20 may be used as crimping pliers to compress or bend pair of wings 50, 60 of implantable device 30. FIG. 3A illustrates a perspective view of the surgical instrument 20 of FIG. 2A engaging interspinous implantable device 30. First elongated section 220 may include a first surface 330 configured to engage a first wing 52 of pair of wings 50 and to exert a compressive force on first wing 52. Second elongated section 230 may include a second surface 340 configured to engage a second wing 54 of pair of wings 50 and to exert a compressive force on second wing 54. Further, guide member 280, being operably connected to first elongated section 220 and second elongated section 230 by connector pieces 260, 270, may facilitate the production of a symmetric displacement or bending of wings 52, 54 of pair of wings 50, and/or application of approximately symmetric compressive forces on first wing 52 and second wing 54. As shown, guide member 280 may be configured to securely and properly hold implantable device 30, thereby ensuring the appropriate engagement and alignment

of first and second surfaces 330, 340 with pair of wings 50 to allow evenly applied bending or crimping force, and produce symmetric displacement or bending of pair of wings 50.

FIG. 3B illustrates an end view of surgical instrument 20 of FIG. 2A engaging interspinous implantable device 30 before compression of implant wings 50. As noted previously, guide member 280 may be configured to engage top a surface 56 of device 30. Further, first elongated section 220 and second elongated section 230 may be positioned on opposite sides of implantable device 30 and may engage outer surfaces of wings 52, 54. As shown, first handle portion 200 and second handle portion 210 are in an open position, and a surgeon may compress first handle 200 and second handle 210 together to move first elongated section 220 and second elongated section 230 toward one another and thereby apply a compressive force to the wings 52, 54 sufficient to bend wings 52, 54 inward, as shown in FIG. 3C, to engage a spinous process (not shown) located therebetween.

It is also contemplated that the surgeon may elect to use the surgical instrument 20 to pre-bend the implantable device 30 prior to insertion, such as for example, where the spinous process is relatively thin and the surgeon may decide that a pre-shaped or preloaded implantable device (i.e., one where the wings 52, 54 of a pair of wings 50 are crimped together to form a narrower gap therebetween) would enable a better fit. Alternatively, the surgeon may elect to use surgical instrument 20 to pre-bend implantable device 30 prior to insertion such that the distance or gap between wings 52, 54 is slightly smaller than the width of the spinous process to be placed therebetween. This latter scenario may be desirable for a surgeon when taking into account the degree of flexibility or elasticity of wings 50, 60, which would enable wings 50, 60 to act as a clip on a spinous process.

FIG. 3D illustrates a perspective end view of the underside of the surgical instrument of FIG. 3A, according to an exemplary embodiment. As shown, guide member 280 can include a distal extension 290. Distal extension 290 can provide a relatively thicker material region that will provide additional rigidity to guide member 280, thereby preventing bending of guide member 280 during use. In some embodiments, distal extension 290 can further include a hook section 292 configured to overlap end region 294 of first elongated section 220 and second elongated section 230, thereby further preventing bending of guide member 280.

As noted previously, guide member 280 may be maintained at a fixed symmetric position with respect to first elongated section 220 and second elongated section 230. As guide member 280 may engage implantable device 30 before compression, the fixed relative position of guide member 280 may facilitate equal distribution of compressive forces on wings 52, 54. This configuration may assist a surgeon in securely attaching implantable device 30 to a spinous process by securing wing 52 and wing 54 in approximately symmetric alignment with the spinous process.

In some embodiments, surgical instrument 20 can include additional mechanisms to aid a physician in properly positioning instrument 20 on implant 30. For example, referring again to FIG. 2D, instrument 20 can include a blocking protrusion 320 positioned on guide member 280. Blocking protrusion 320 can be positioned on an upper surface of guide member 280 such that it will contact a portion of implant 30 engaged by guide member 280 and prevent implant 30 from moving too far into guide member 280. Further, it will be understood that the position and size of blocking protrusion 320 can be selected based on the size and configuration of a selected implant 30 and/or instrument 20.

FIG. 4 illustrates a portion of a kit or surgical set 400, including a surgical instrument 410 and implantable device 30, according to an exemplary disclosed embodiment. As shown, implantable device 30 may comprise an interspinous implant similar to that described above with reference to FIG. 1. As noted previously, implantable device 30 may include at least one pair of wings 50, which may be configured to engage a spinous process (not shown). During an implantation procedure, a surgeon can determine that the distance between first wing 52 and second wing 54 is insufficient to allow the implant to be properly implanted, i.e., the spinous process is too large to fit between wings 52, 54. Therefore, it may be desirable to spread wings 52, 54 apart, thereby increasing the distance between first wing 52 and second wing 54. Surgical instrument 410 may be used to increase the distance between wings 50 to facilitate implantation. Further, instrument 410 may be configured to provide equal bending forces to both wings 52, 54 of pair of wings 50 to bend wings 52 and wing 54 substantially symmetrically.

FIG. 5A illustrates a perspective view of surgical instrument 410 of FIG. 4, according to an exemplary disclosed embodiment, and FIG. 5B illustrates an exploded view of the surgical instrument of FIG. 5A. As shown, instrument 410 includes a first handle portion 420 and a second handle portion 430. First handle portion 420 may be connected to a first elongated section 440, and second handle portion 430 may be connected to a second elongated section 450. First handle portion 420 may be integrally formed with first elongated section 440, and second handle portion 430 may be integrally formed with second elongated section 450. Alternatively, the pieces may be separately formed and then joined. Further, first handle portion 420 and second handle portion 430 may be joined at a hinge region 460. Hinge region 460 may form a rotatable connection between first handle portion 420 and second handle portion 430. As shown, hinge region 460 may include a hinge connector 470, such as, for example, a screw, a pin, a bolt, or another type of suitable connector.

Similar to surgical instrument 20 previously described, a leaf spring mechanism 170 may also be provided between the first handle portion 420 and the second handle portion 430 to provide a biased resistance-force between handle portions 420, 430. Leaf spring mechanism 170 may comprise two leaf springs 172, 174. One leaf spring 172 may terminate into a male portion 176, while another leaf spring 174 may terminate into a female portion 178, as shown. Leaf springs 172, 174 may rest against one another in a mobile, hinged configuration. This hinged configuration enables leaf springs 172, 174 to pivot with respect to one another. Each of leaf springs 172, 174 may be attached to handle portions 420, 430 with a fastener 190. As shown in detail in FIG. 5B, leaf springs 172, 174 may attach to first and second handle portions 420, 430, respectively, by securing fasteners 190 through holes 192 on leaf springs 172, 174, and into holes 194 of the first and second handle regions 420, 430. Fasteners 190 may comprise any suitable connector such as, for example, a screw, a bolt, or a pin, as is commonly used in the art.

A surgeon may grasp first handle portion 420 and second handle portion 430, and by increasing or decreasing the distance between first handle portion 420 and second handle portion 430, may increase or decrease the distance between first elongated section 440 and second elongated section 450. In one embodiment, as the distance between first handle portion 420 and second handle portion 430 is increased, the distance between first elongated section 440 and second elongated section 450 will decrease. Conversely, as the distance between first handle portion 420 and second handle portion

430 is decreased, the distance between first elongated section 440 and second elongated section 450 will increase.

FIG. 5C illustrates an exploded view of an end region of the surgical instrument 410 of FIG. 5A, according to an exemplary disclosed embodiment. As shown, instrument 410 may further include a guide member 480 and at least two connector pieces 490, 500. First connector piece 490 may form a rotatably mobile connection with first elongated section 440, and second connector piece 500 may form a rotatably mobile connection with second elongated section 450. Connector pieces 490, 500 may further form a common rotatably mobile connection 510 with one another. Further, connection 510 may form a common connection with guide member 480. In some embodiments, at least one connector piece may include a protrusion 512 configured to engage an elongated groove 514 in guide member 480 to form a slidable connection between connector pieces 490, 500 and guide member 480. Connector pieces 490, 500 may be rotatably joined at protrusion 512 and may secure guide member 480 in a fixed symmetric position with respect to first elongated section 440 and second elongated section 450 during movement of first elongated section 440 and second elongated section 450 about hinge region 460.

Similar to guide member 280 and connector pieces 260, 270, guide member 480 and connector pieces 490, 500 may facilitate symmetric displacement of wings 52, 54. For example, as noted previously, due to design tolerances and production variables, the thicknesses and material properties of wings 52, 54 may vary slightly. Therefore, if equal bending forces are applied to each wing 52, 54 the displacement or degree of bending achieved for each wing 52, 54 may vary, thereby producing an asymmetric implant shape and possibly producing improper engagement with a spinous process when 52, 54 and bend towards one another after implantation. The guide member 480 and connector pieces 490, 500 provide symmetric displacement of wings 52, 54 even when the dimensions and/or material properties of wings 52, 54 are different.

FIG. 5D illustrates a perspective view of a surgical instrument 410', according to another exemplary disclosed embodiment. Surgical instrument 410' is identical to surgical instrument 410, but with an additional visual gauge element 180 similar to the one described with surgical instrument 20'. The gauge element 180 comprises two arms 182, 184, each arm being attached to a handle region 420, 430, respectively, of the surgical instrument 410'. The free ends of the arms are configured to slide against one another when the surgical instrument 410' is engaged. Visual indicators or marks (not shown) on arms 182, 184 are aligned as the surgical instrument 410' is compressed or squeezed together, thereby indicating to the user the distance between implant wings 52, 64 as they are spread apart.

FIG. 6A illustrates a perspective view of surgical instrument 410 of FIG. 4 engaging an interspinous implant. As shown, guide member 480 is placed around pair of wings 50 of implantable device 30. FIG. 6B illustrates an enlarged top view of surgical instrument 410 of FIG. 6A engaging interspinous implantable device 30 before expansion of implant wings 50. As shown, guide member 480 includes two distal protrusions 520, 530 positioned adjacent to outer surfaces of wings 50. Distal protrusions 520, 530 may serve as guide ramps or bumpers, providing a support surface against which pair of wings 50 may be bent outward. Further, first elongated section 440 may include a surface 540, and second elongated section 450 may include a second surface 550. As a surgeon compresses handle portions 420, 430 together, first surface 540 and second surface 550 may move outwardly and exert an

11

expanding force on wings **50**, thereby spreading wings **50** apart, as shown in FIG. **6C**. Thus, surgical instrument **410** may be used as spreading pliers to evenly expand the distance between pair of wings **50**, **60** of implantable device **30** in order to accommodate an oversized interspinous process therebetween. In some embodiments, distal protrusions **520**, **530** will be positioned equidistant from a long axis of instrument **410**, thereby allowing wings **52**, **54** to be evenly bent outward by applying force against wings **52**, **54** and protrusions **520**, **530**.

It is contemplated that a surgical set or kit set **10** of the present invention may include one or more of surgical instruments **20**, **410** and may include one or more of implantable devices **30**. The surgical set or kit may further include a sizing implant for sizing an interspinous space that will receive an implant. Alternatively, it is possible to provide an instrument set without an implantable device and/or sizing implement. The surgical instruments **20**, **410** may be configured specifically to be used with the implantable device **30** provided with the surgical set or kit. The surgical instruments **20**, **410** can be calibrated to either bend together or spread apart a pair of wings **50**, **60** within a predetermined range of angles and forces, so as not to overextend the wings **50**, **60** and cause damage, weakening, or breakage.

To implant device **30**, a surgeon will first expose the interspinous space to be treated using an incision near the selected vertebral levels. Next, the surgeon will partially or completely remove the posterior spinal ligaments at the selected vertebral level. Then, to make space for an implantable device **30**, the surgeon will remove part or all of the interspinous ligament.

Prior to implantation of implantable device **30**, the surgeon may size and/or shape the selected interspinous space. FIG. **7A** illustrates a portion of a surgical kit, including a sizing and insertion implement **700**, according to an exemplary disclosed embodiment. As shown, implement **700** includes a first sizing end **710** that can be inserted between two spinous processes **702**, **704**. Sizing end **710** is configured to have a size and shape approximately matching the size and shape of an implantable device of a surgical kit, thereby allowing a surgeon to test the size of an implantable device before implantation. Further, as noted previously, the surgical kits of the present disclosure can include implants having a variety of different sizes, and accordingly, the kit can further include sizing implements corresponding to the size of each implant.

The surgical kits of the present disclosure can further include insertion implements. For example, in some embodiments, implement **700** can include a second implantation end **720**. For example, FIG. **7B** illustrates the implement of FIG. **7A** engaging an interspinous implant **30**, according to an exemplary disclosed embodiment. As shown, implantation end **720** is configured to engage a space between U-shaped body **40** of implant **30**, thereby allowing a surgeon to manipulate device **30** and push device **30** into a selected anatomic space. Alternatively, surgical instrument **20**, as described above, can be used to grasp an implant **30** to facilitate manipulation and insertion.

It should be noted that a number of variations to the implantation technique and selected implantable device are envisioned. For example, in some embodiments, the spinous processes may be cut or shaped prior to implantation of selected devices. Suitable devices for shaping spinous processes are described in detail in co-pending U.S. patent application Ser. No. 11/676,141 to Rudolf Bertagnoli et al., which is titled, "Method and System for Performing Interspinous Space Preparation for Receiving an Implant," and which is hereby incorporated by reference in its entirety.

12

In addition, suitable implantable devices **30** can include surface projections **725**, barbs, or other features on the device body or inner surfaces of the wing members. These surface projections **725** can further improve attachment of the device to spinous processes. In addition, in some embodiments, a surgeon may secure an implant to a spinous process by forming a hole transversely through the spinous process and placing a screw, rivet or other connection through the hole in the spinous process and through a hole **722** in at least one of the elongated wing members of an implantable device **30**. Such a process is disclosed in U.S. Provisional Patent Application No. 60/868,080, filed Nov. 30, 2006 and entitled "Interspinous Vertebral Stabilization System," which is hereby incorporated by reference in its entirety. Further, as noted previously, other suitable implantable devices can be selected, including devices used to treat various vertebral levels including vertebral levels adjacent the lumbosacral region **730**.

Other embodiments of the invention will be apparent to those skilled in the art from consideration of the specification and practice of the invention disclosed herein. It is intended that the specification and examples be considered as exemplary only, with a true scope and spirit of the invention being indicated by the following claims.

What is claimed is:

1. A surgical kit, comprising:

at least one spinal implant, including:

an implant body; and

at least two elongated wing members configured to engage opposite sides of a vertebral spinous process; and

at least one surgical instrument for crimping the at least two elongated wing members to the vertebral spinous process, including:

a first elongated section having a first surface region configured to engage a first elongated wing member of the at least two elongated wing members of the at least one spinal implant;

a second elongated section having a second surface region configured to engage a second elongated wing member of the at least two elongated wing members of the at least one spinal implant;

a hinge region connecting the first elongated section to the second elongated section such that the first surface region of the first elongated section and second surface region of the second elongated section are mobile with respect to one another; and

a guide member operatively connected to the first elongated section and second elongated section at the hinge region such that during movement of the first surface region of the first elongated section and the second surface region of the second elongated section the guide member is maintained at a fixed symmetrical position with respect to the first surface region of the first elongated section and the second surface region of the second elongated section;

wherein deployment of the surgical instrument exerts a compressive force sufficient to bend the at least two elongated wing members of the spinal implant inward to fixedly engage the spinous process.

2. The surgical kit of claim 1, wherein the surgical instrument further includes a first connector piece forming a hinged connection with the first elongated section and the guide member.

13

3. The surgical kit of claim 2, wherein the surgical instrument further includes a second connector piece forming a hinged connection with the second elongated section and the guide member.

4. The surgical kit of claim 3, wherein the hinged connection between the first connector piece and first elongated section is formed at a region of the first elongated section other than the hinge region, and the hinged connection between the second connector piece and second elongated section is formed at a region of the second elongated section other than the hinge region.

5. The surgical kit of claim 3, wherein the hinged connection between the first connector and the guide member is formed at the same location on the guide member as a connection between the second connector and the guide member.

6. The surgical kit of claim 5, wherein the surgical instrument has a plane through the hinged connection between the first connector and the guide member such that the first elongated section and second elongated section are mirror images on each side of the plane.

7. The surgical kit of claim 1, wherein the surgical instrument further includes a first handle portion extending from the first elongated section and a second handle portion extending from the second elongated section.

8. The surgical instrument set of claim 7, wherein the first handle portion and second handle portion are configured to move between a first, open position and a second, closed position.

9. The surgical kit of claim 8, wherein movement of the first handle portion and second handle portion from the first, open position to the second, closed position causes the first surface region of the first elongated section and the second surface region of the second elongated section to move closer together.

10. The surgical kit of claim 1, wherein the first surface region of the first elongated section and the second surface region of the second elongated section are configured to move between a surface region open position to a surface region closed position.

11. The surgical kit of claim 10, wherein a distance between the first surface region and second surface region in the surface region closed position is less than a width of the guide member.

12. The surgical kit of claim 11, wherein the guide member includes a first distal protrusion on a first side of the guide member and a second distal protrusion on a second side of the guide member.

13. The surgical kit of claim 12, wherein the first distal protrusion is configured to engage an outer surface of one of the at least two elongated wing members, and the second distal protrusion is configured to engage an outer surface of another of the at least two elongated wing members.

14. The surgical kit of claim 12, wherein the first distal protrusion has a first inner contact surface and the second distal protrusion has a second inner contact surface, and the first inner contact surface and second inner contact surface are equidistant from a longitudinal axis of the instrument.

15. The surgical kit of claim 14, wherein a distance between an outer surface of the first elongated section and an outer surface of second elongated section in the surface region closed position is greater than a width of the guide member.

16. The surgical kit of claim 1, wherein the guide member is configured to hold the implant body centered with respect to the first and second surface regions configured to contact a portion of the spinal implant.

14

17. The surgical kit of claim 1, wherein the at least one spinal implant includes two elongated wing members on an upper portion of the implant body and two elongated wing members on a lower portion of the implant body.

18. The surgical kit of claim 1, wherein the at least two elongated wing members include surface projections on at least one inner surface of the wing members to secure the implant to the bone of a spinous process.

19. The surgical kit of claim 1, wherein the implant body includes surface projections to secure the implant to the bone of the spinous process.

20. A surgical kit, comprising:

an implantable interspinous device comprising an implant body and a pair of elongated wing members for receiving a vertebral spinous process; and

a surgical instrument for crimping the elongated wing members to the vertebral spinous process, including:

a first surface configured to engage an outer surface of a first elongated wing member of the pair of elongated wing members of the implantable interspinous device;

a second surface configured to engage an outer surface of a second elongated wing member of the pair of elongated wing members of the implantable interspinous device;

a first handle portion connected to the first surface and configured to translate a first compressive force to the first surface;

a second handle portion connected to the second surface and configured to translate a second compressive force to the second surface; and

a guide member configured to center and hold the implantable device relative to the surgical instrument in a manner that permits the first and second surfaces to substantially evenly displace the outer surfaces of the first and second elongated wing members as the first and second surfaces contact the implantable device;

wherein deployment of the surgical instrument translates a compressive force to the first and second surfaces sufficient to bend the elongated wing members inward to fixedly engage the spinous process.

21. The surgical kit of claim 20, wherein the first surface is configured to apply the first force to the outer surface of the first elongated wing member and the second surface is configured to apply the second force to the outer surface of the second elongated wing member, wherein the first and second forces are not equal.

22. The surgical kit of claim 21, wherein the first handle portion and second handle portion are configured to move between a first, open position and a second, closed position.

23. The surgical kit of claim 22, wherein movement of the first handle portion and second handle portion from the first, open position to the second, closed position causes the first surface and the second surface to move closer together.

24. The surgical kit of claim 21, wherein the first surface and the second surface are configured to move between a first open position and a second closed position.

25. The surgical kit of claim 24, wherein a distance between the first surface and second surface in the closed position is less than a width of the guide member.

26. The surgical kit of claim 25, wherein the guide member includes a first distal protrusion on a first side of the guide member and a second distal protrusion on a second side of the guide member.

27. The surgical kit of claim 26, wherein the first distal protrusion has a first inner contact surface and the second

15

distal protrusion has a second inner contact surface, and the first inner contact surface and second inner contact surface are equidistant from a longitudinal axis of the instrument.

28. The surgical kit of claim 24, wherein a distance between an outer surface of the first surface and an outer surface of the second surface in the surface region closed position is greater than a width of the guide member.

29. The surgical kit of claim 20, further including a first connector piece and a second connector piece, wherein the first and second connector pieces form a hinged connection with one another and form a sliding connection with the guide member.

30. The surgical kit of claim 29, wherein a hinged connection between the first connector piece and the guide member is formed at the same location on the guide member as a connection between the second connector and the guide member.

31. The surgical kit of claim 30, wherein the guide member includes an elongate groove having a long axis aligned with a central longitudinal axis of the surgical instrument.

32. A surgical kit, comprising:

a spinal implant, including:

an implant body; and

a pair of wings for receiving a vertebral spinous process; and

a surgical instrument for crimping the pair of wings to the vertebral spinous process, including:

a handle assembly at a proximal end of the instrument comprising first and second handle portions; and

an implant engagement assembly at a distal end of the instrument, the implant engagement assembly including:

first and second elongate sections connected at a hinge region, the elongate sections being movable relative to one another to engage the spinal implant therebetween and exert a compressive force on an outer surface of the pair of wings; and

16

a guide member positioned between the first and the second elongate sections and operatively connected to the elongate sections, the guide member being fixed in a symmetrical position relative to the elongate sections during the movement of the elongate sections about the hinge region;

wherein deployment of the surgical instrument exerts a compressive force sufficient to bend the pair of wings inward to fixedly engage the spinous process.

33. The surgical kit of claim 32, wherein movement of the first and the second handle portions relative to one another causes the relative movement between the first and the second elongate sections about the hinge region.

34. The surgical kit of claim 32, wherein the guide member is configured to securely hold the spinal implant and allow symmetric engagement of the first and second elongate sections with the spinal implant.

35. The surgical kit of claim 32, wherein the guide member is connected to the elongate sections by a pair of connector pieces.

36. The surgical kit of claim 35, wherein the pair of connector pieces form a common sliding connection with the guide member.

37. The surgical kit of claim 35, wherein a first connector piece of the pair of connector pieces forms a first rotatable connection with the first elongate section, and a second connector piece of the pair of connector pieces forms a second rotatable connection with the second elongate section.

38. The surgical kit of claim 37, wherein the first and the second connector pieces form a common rotatable connection with one another.

39. The surgical kit of claim 38, wherein the first and the second connector pieces are connected to the guide member at the common rotatable connection.

* * * * *