



US008823859B2

(12) **United States Patent**
Fujimori et al.

(10) **Patent No.:** **US 8,823,859 B2**
(45) **Date of Patent:** **Sep. 2, 2014**

(54) **IMAGE PICKUP UNIT, OPTICAL UNIT, AND MANUFACTURING METHOD FOR THE IMAGE PICKUP UNIT**

(75) Inventors: **Noriyuki Fujimori**, Suwa (JP); **Kazuaki Kojima**, Suwa (JP)

(73) Assignee: **Olympus Corporation**, Tokyo (JP)

(*) Notice: Subject to any disclaimer, the term of this patent is extended or adjusted under 35 U.S.C. 154(b) by 374 days.

(21) Appl. No.: **12/574,157**

(22) Filed: **Oct. 6, 2009**

(65) **Prior Publication Data**
US 2010/0085466 A1 Apr. 8, 2010

(30) **Foreign Application Priority Data**
Oct. 8, 2008 (JP) 2008-262070
Oct. 10, 2008 (JP) 2008-264503

(51) **Int. Cl.**
H04N 5/225 (2006.01)
A62B 1/04 (2006.01)
A61B 1/04 (2006.01)
H04N 5/232 (2006.01)
G02B 13/00 (2006.01)
G02B 7/02 (2006.01)
G02B 23/24 (2006.01)
A61B 1/05 (2006.01)
A61B 1/00 (2006.01)

(52) **U.S. Cl.**
CPC **G02B 23/243** (2013.01); **G02B 13/0085** (2013.01); **G02B 13/006** (2013.01); **G02B 13/007** (2013.01); **G02B 13/0035** (2013.01); **G02B 7/02** (2013.01); **G02B 13/0065** (2013.01); **A61B 1/051** (2013.01); **A61B 1/00096** (2013.01); **H04N 5/2254** (2013.01)

USPC **348/340**; 348/373; 348/335; 348/65; 348/68; 348/211.2

(58) **Field of Classification Search**
USPC 348/340, 335, 370, 371, 65-70, 348/373-376, 211.2; 455/344, 91, 101; 438/48, 800, 22, 26, 28, 29, 51; 257/80-82; 250/208.1; 600/160
See application file for complete search history.

(56) **References Cited**

U.S. PATENT DOCUMENTS

4,692,608 A * 9/1987 Cooper et al. 348/340
5,371,384 A * 12/1994 Wada 257/82
6,476,851 B1 * 11/2002 Nakamura 348/65
6,828,542 B2 * 12/2004 Ye et al. 250/208.1
7,242,027 B2 * 7/2007 Schranz 257/80

(Continued)

FOREIGN PATENT DOCUMENTS

JP Hei-7-24088 6/1995
JP 10-319297 12/1998

(Continued)

Primary Examiner — Nhan T Tran

(74) *Attorney, Agent, or Firm* — Scully, Scott, Murphy & Presser, P.C.

(57) **ABSTRACT**

A manufacturing method for an optical unit includes: a step of bonding plural lens wafers, on which optical components are formed, and forming a lens unit wafer including plural lens units; a step of bonding a bending optical element wafer including plural bending optical elements to a first surface of the lens unit wafer such that the plural bending optical elements are respectively opposed to the plural lens units and forming an optical unit wafer; and a step of separating and individualizing the optical unit wafer for each of the lens units and the bending optical elements and manufacturing plural optical units.

10 Claims, 16 Drawing Sheets

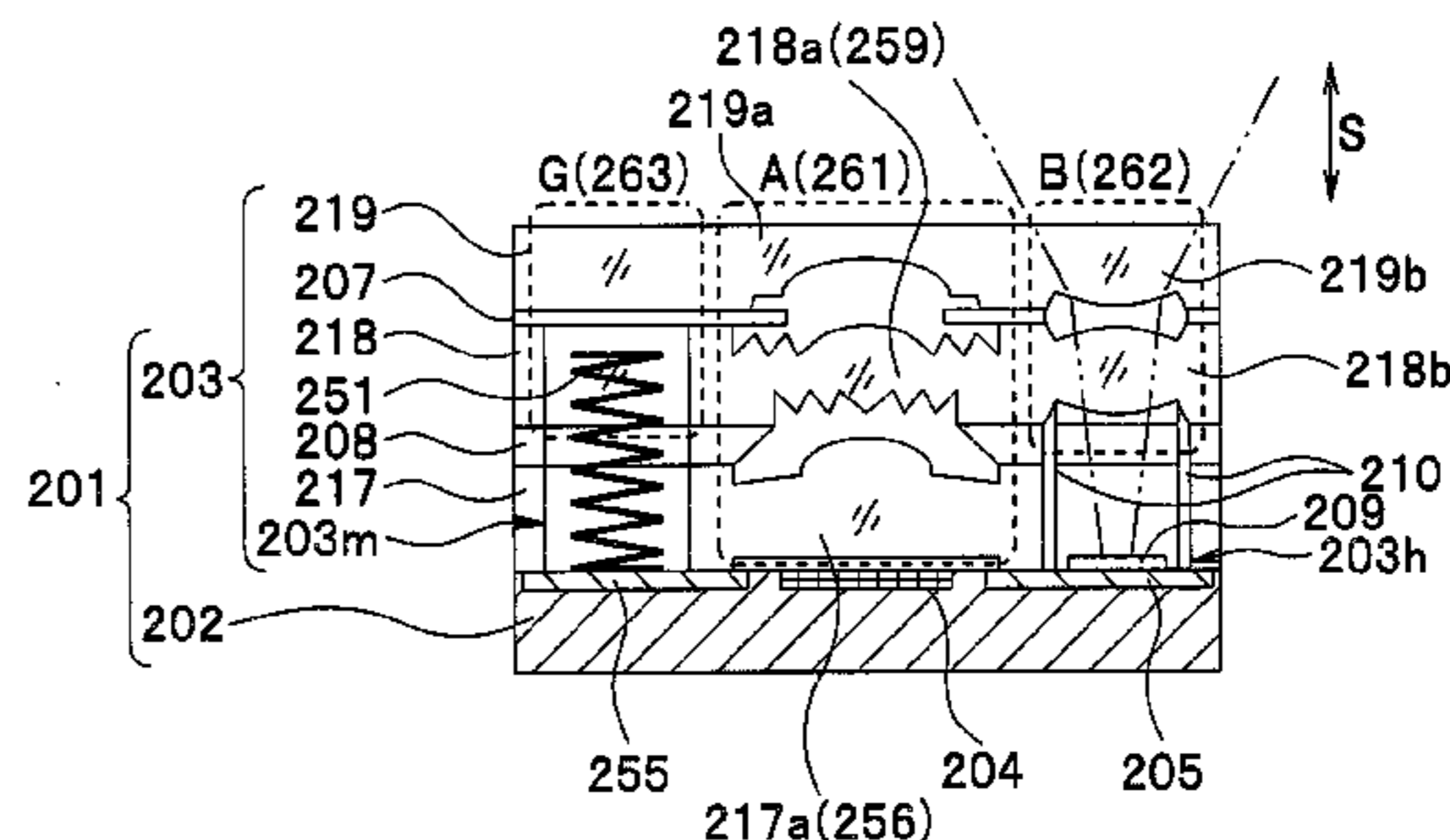
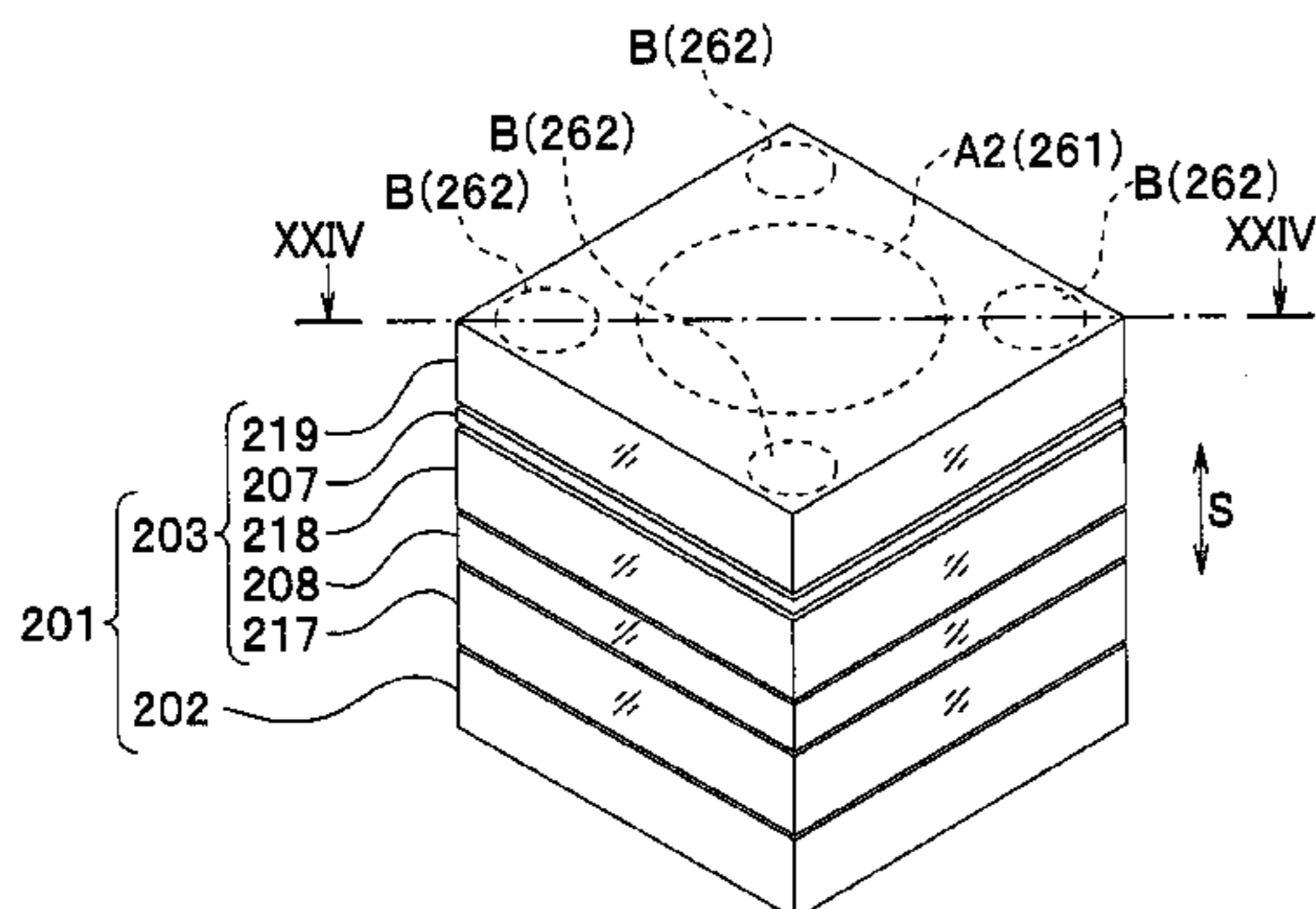

(56)

References Cited

FOREIGN PATENT DOCUMENTS

U.S. PATENT DOCUMENTS

7,787,939 B2 * 8/2010 Jacobsen et al. 348/65
2004/0225189 A1 * 11/2004 Kimoto et al. 600/160
2005/0124858 A1 * 6/2005 Matsuzawa et al. 600/176
2006/0232668 A1 * 10/2006 Horn et al. 348/71
2006/0258901 A1 * 11/2006 Fujimori et al. 600/101
2007/0166029 A1 * 7/2007 Lee et al. 396/529
2009/0244259 A1 * 10/2009 Kojima et al. 348/45

JP 2004-29554 1/2004
JP 2005-539276 A 12/2005
JP 2006-236516 A 9/2006
JP 2007-068894 3/2007
WO 2004/027880 A2 4/2004
WO WO 2008/118085 A2 10/2008

* cited by examiner

FIG. 1
(PRIOR ART)

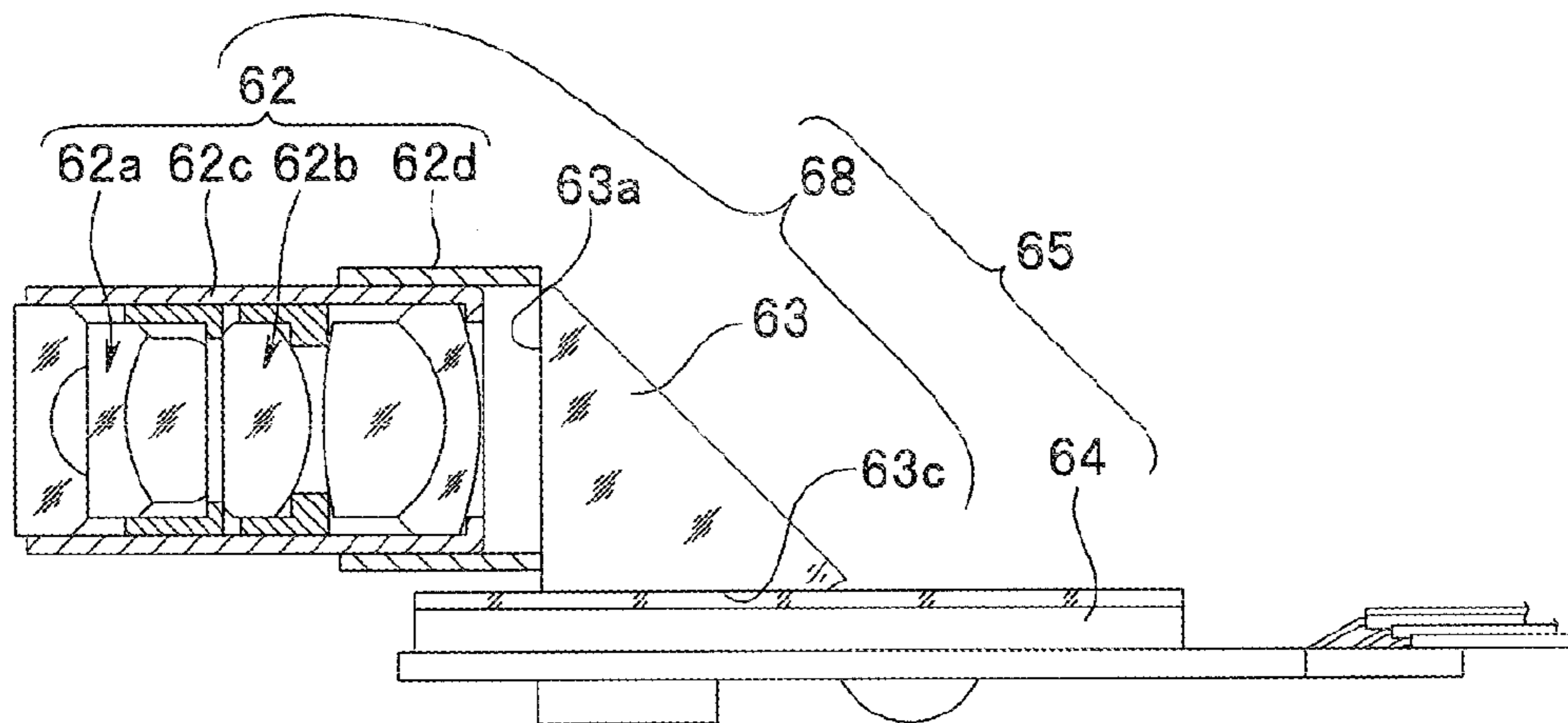

FIG.2
(PRIOR ART)

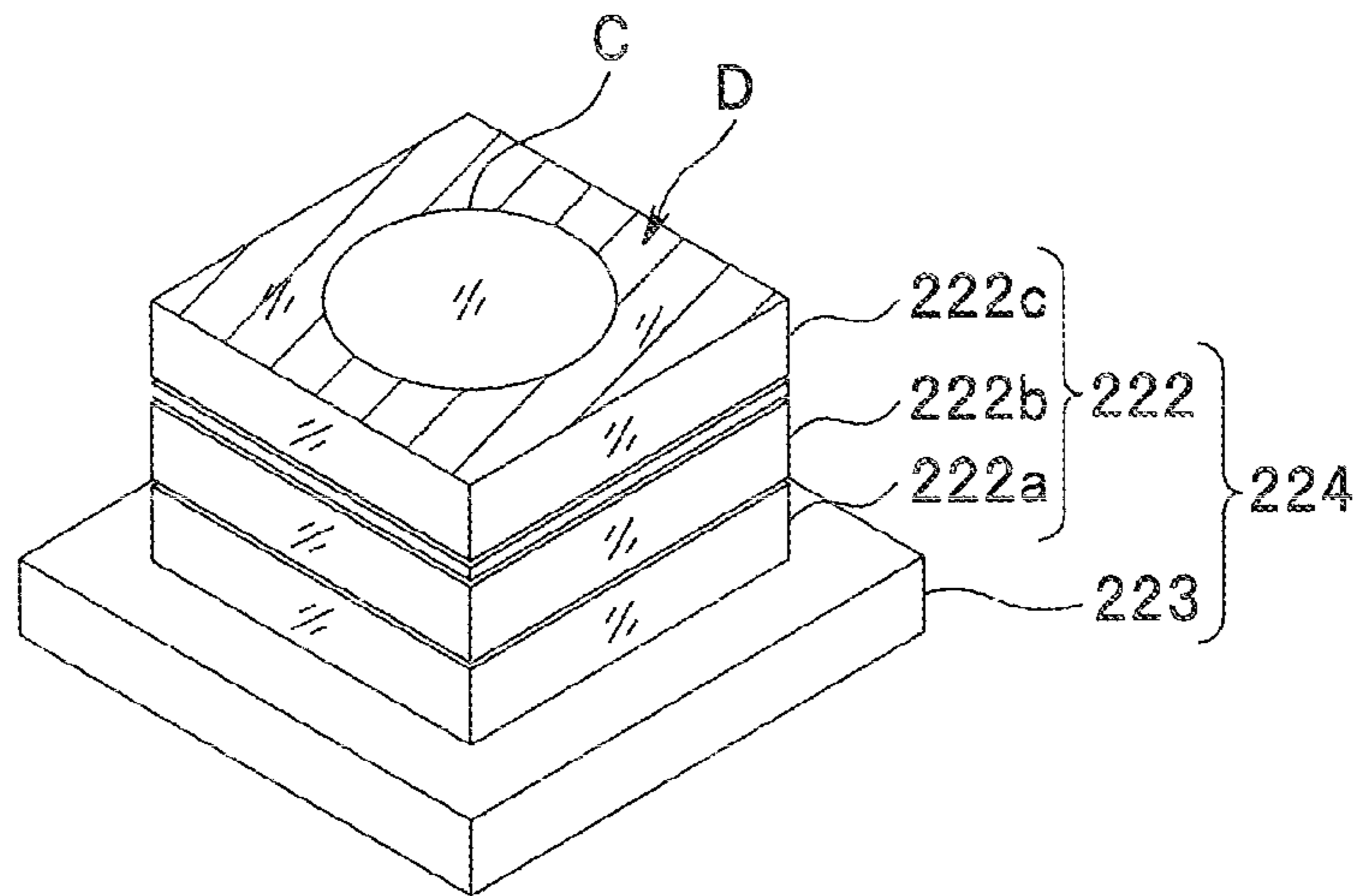

FIG.3
(PRIOR ART)

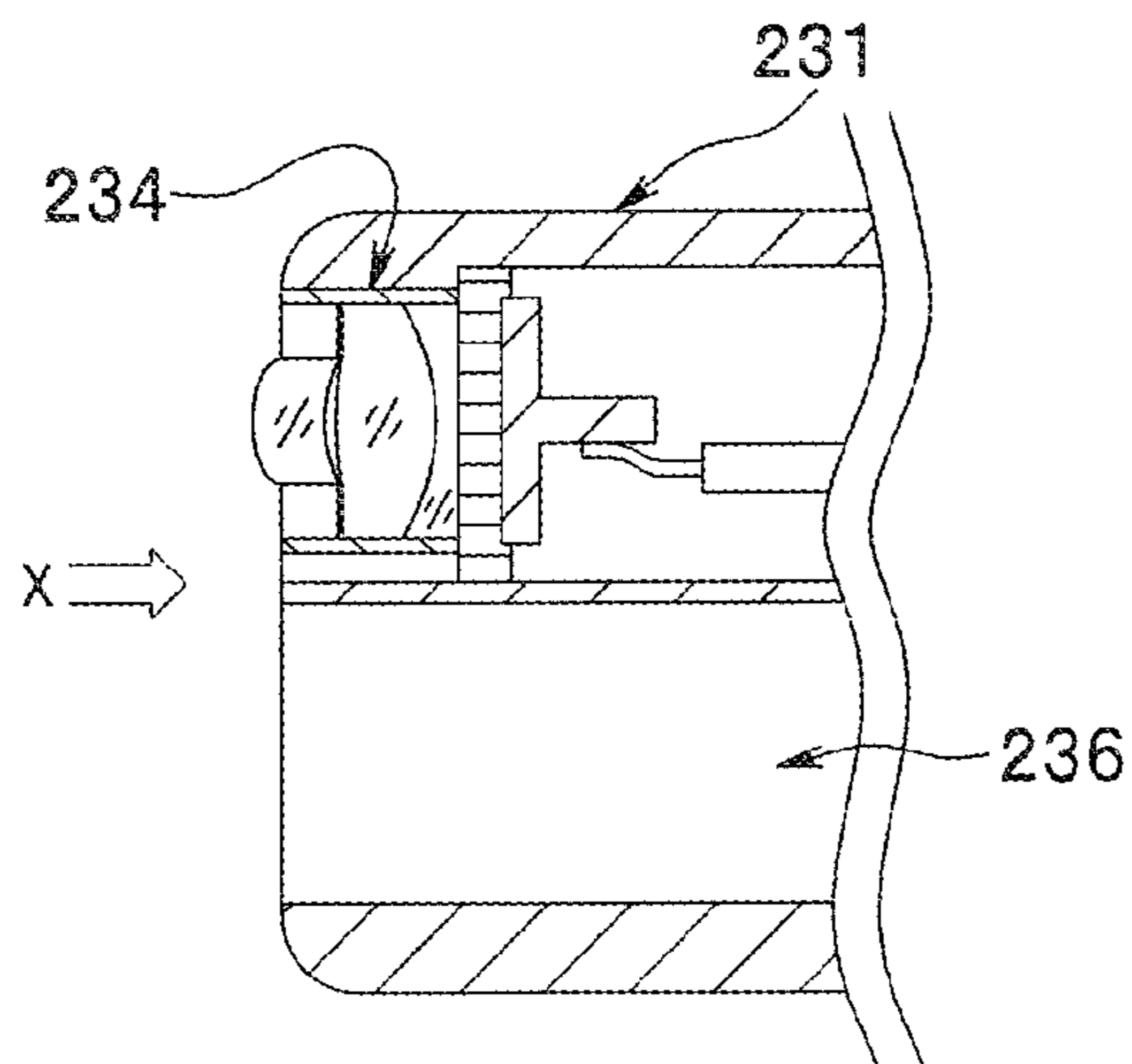

FIG. 4
(PRIOR ART)

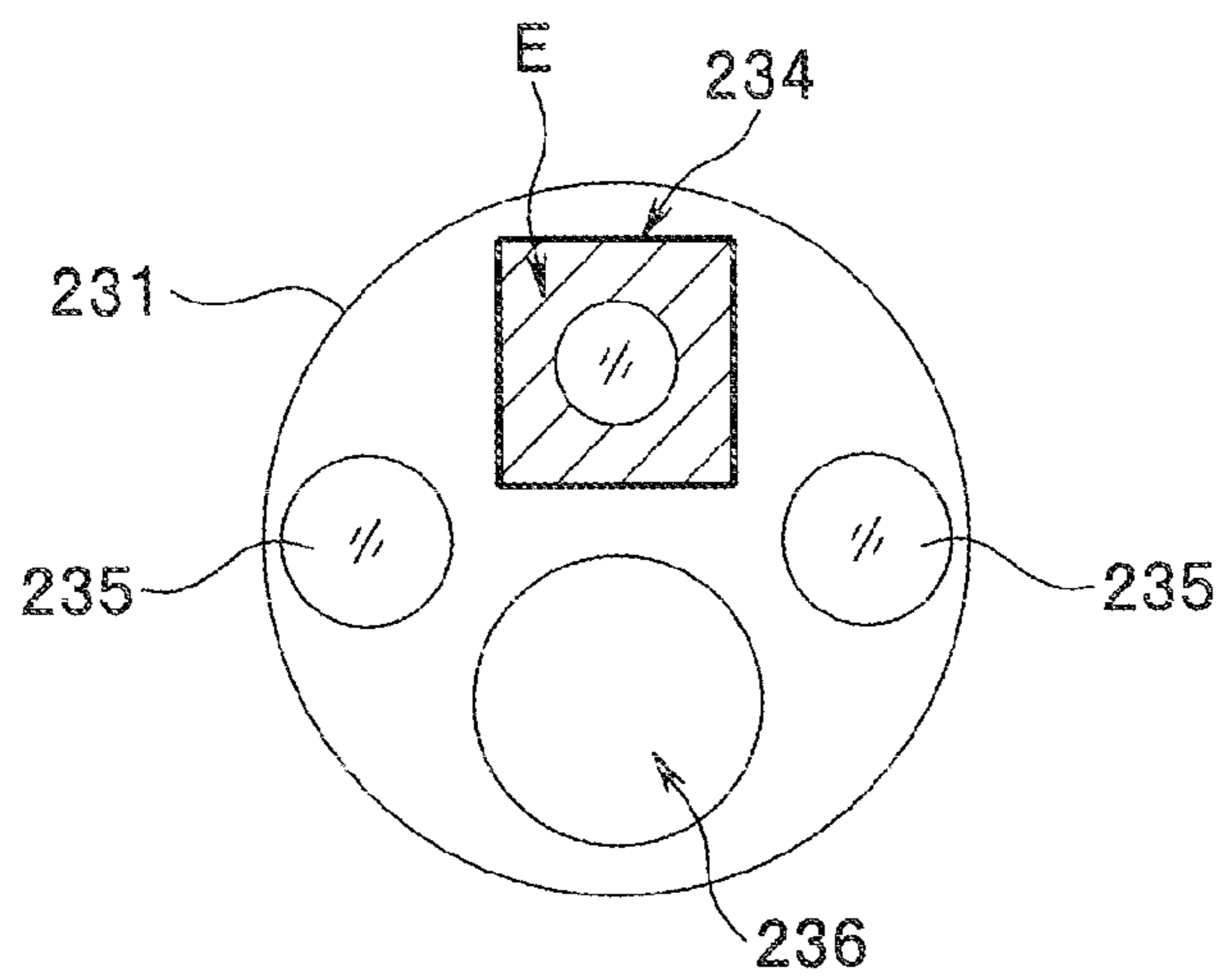

FIG. 5

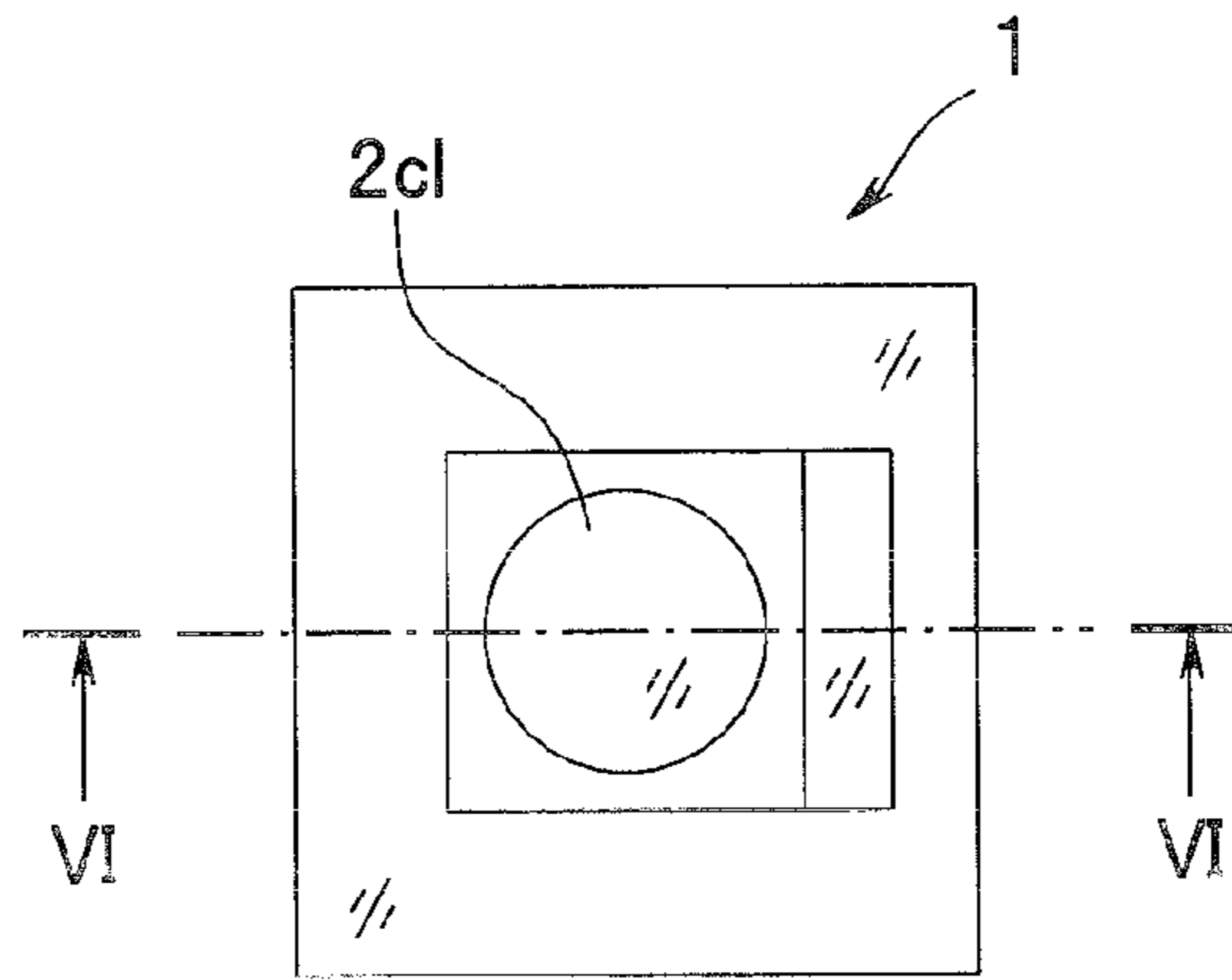

FIG. 6

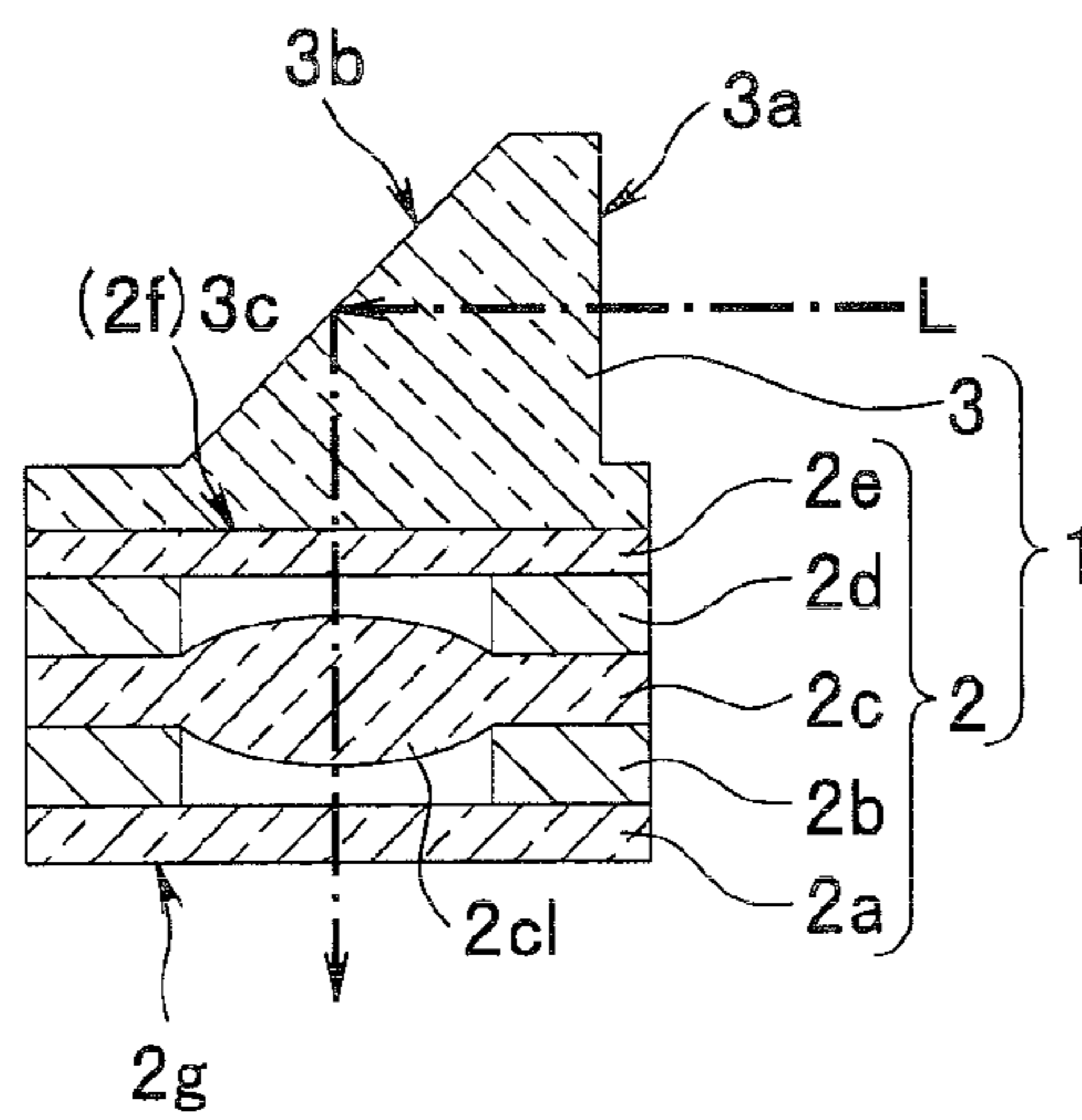

FIG. 7

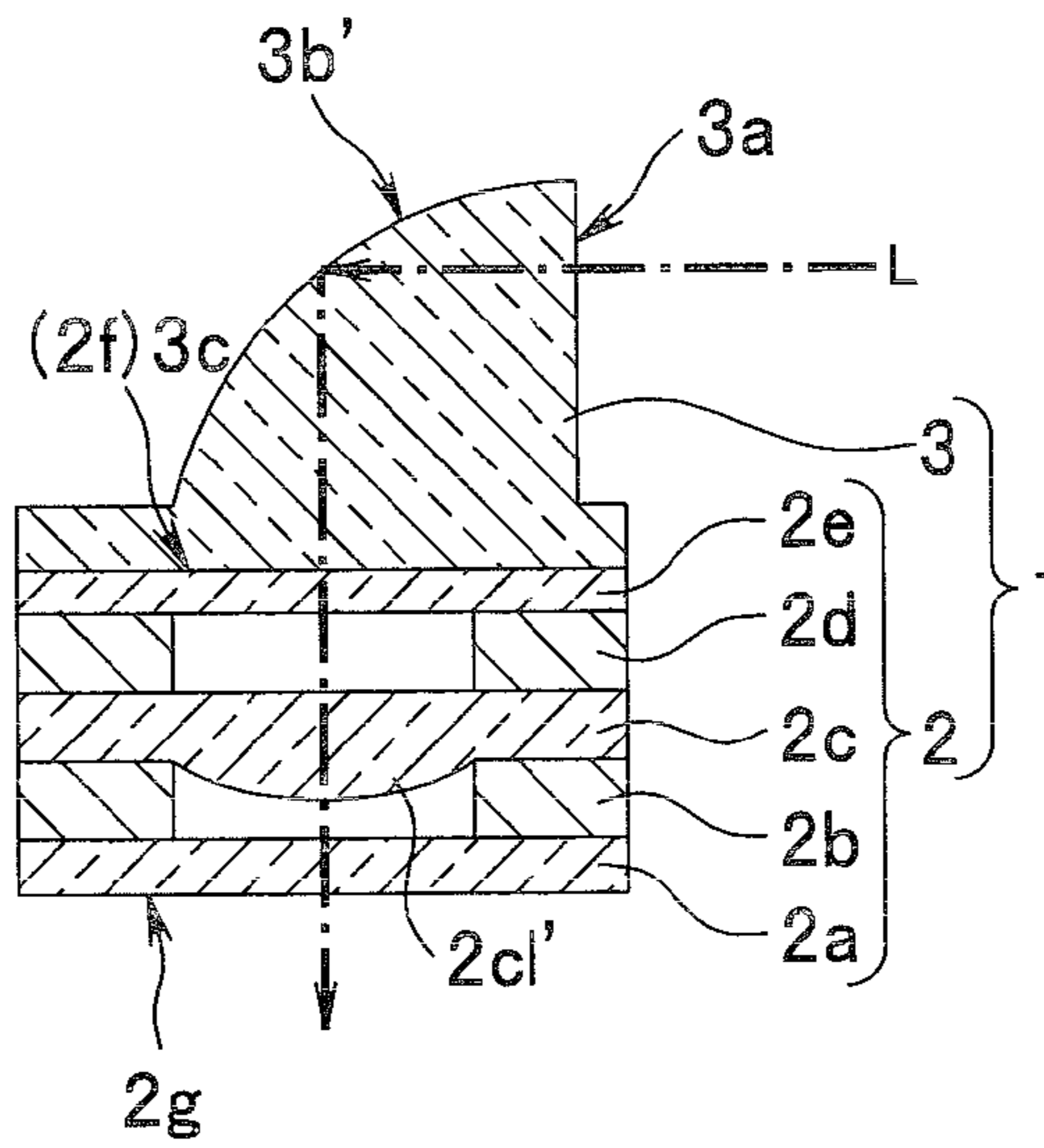

FIG. 8

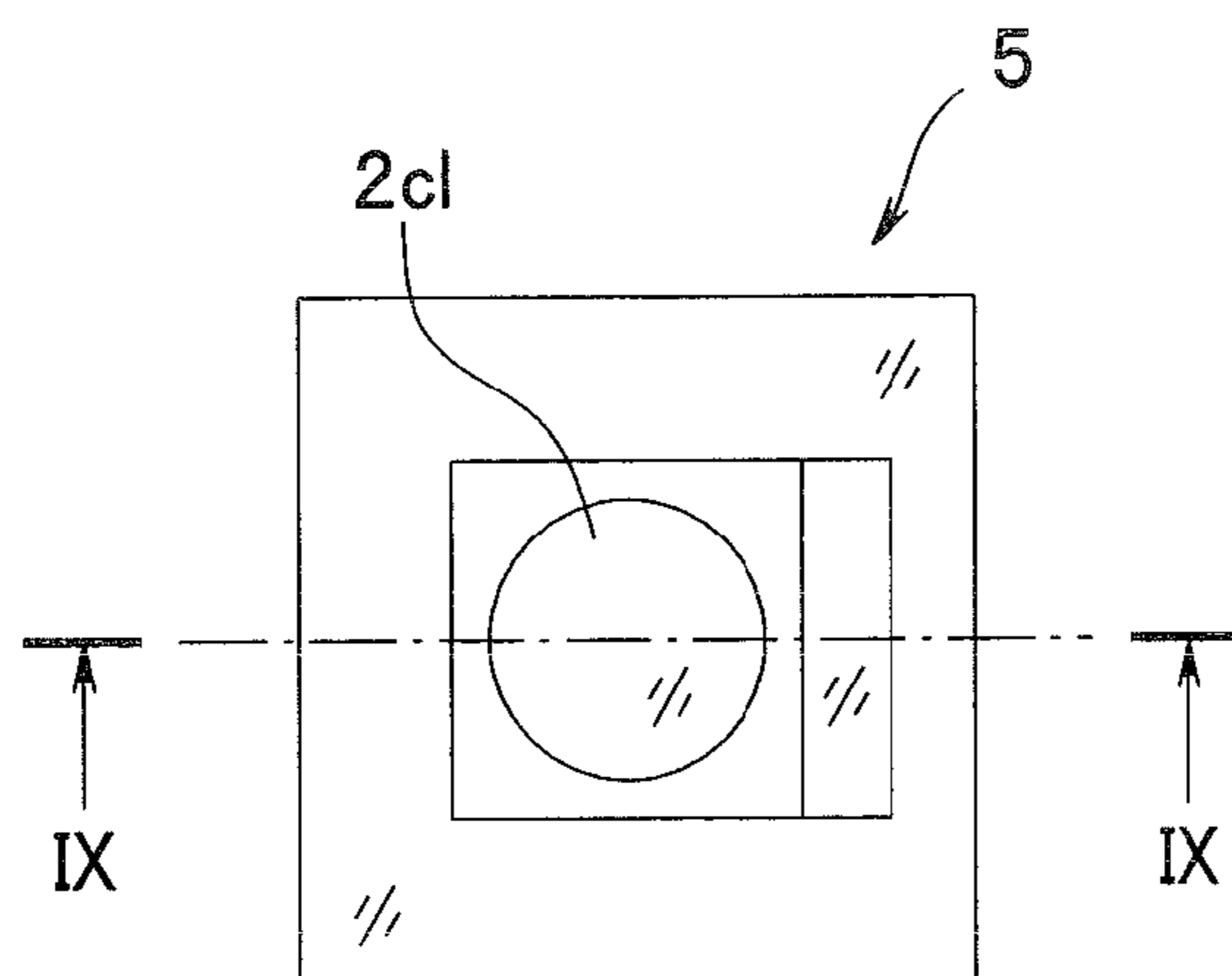

FIG. 9

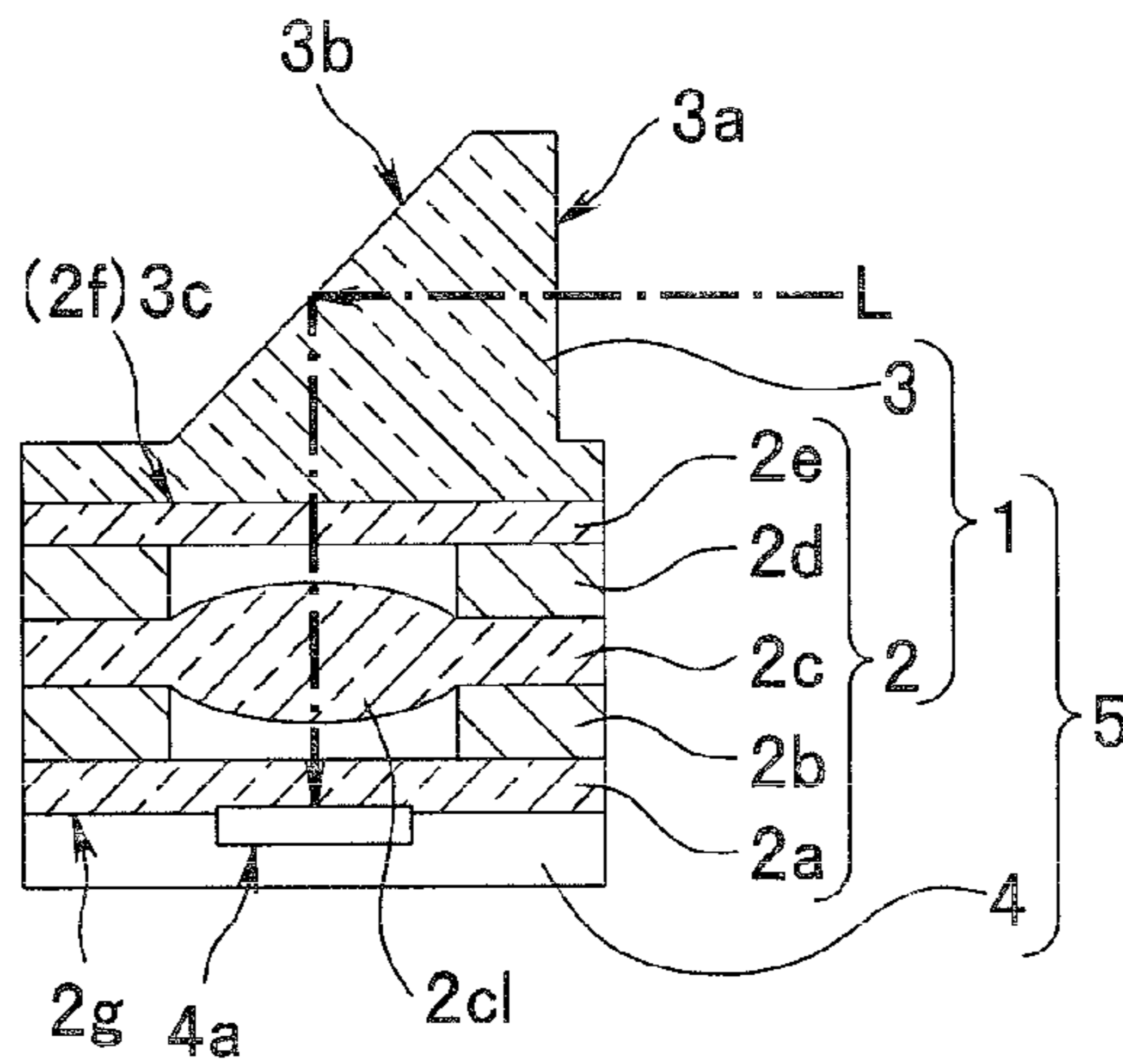

FIG. 10

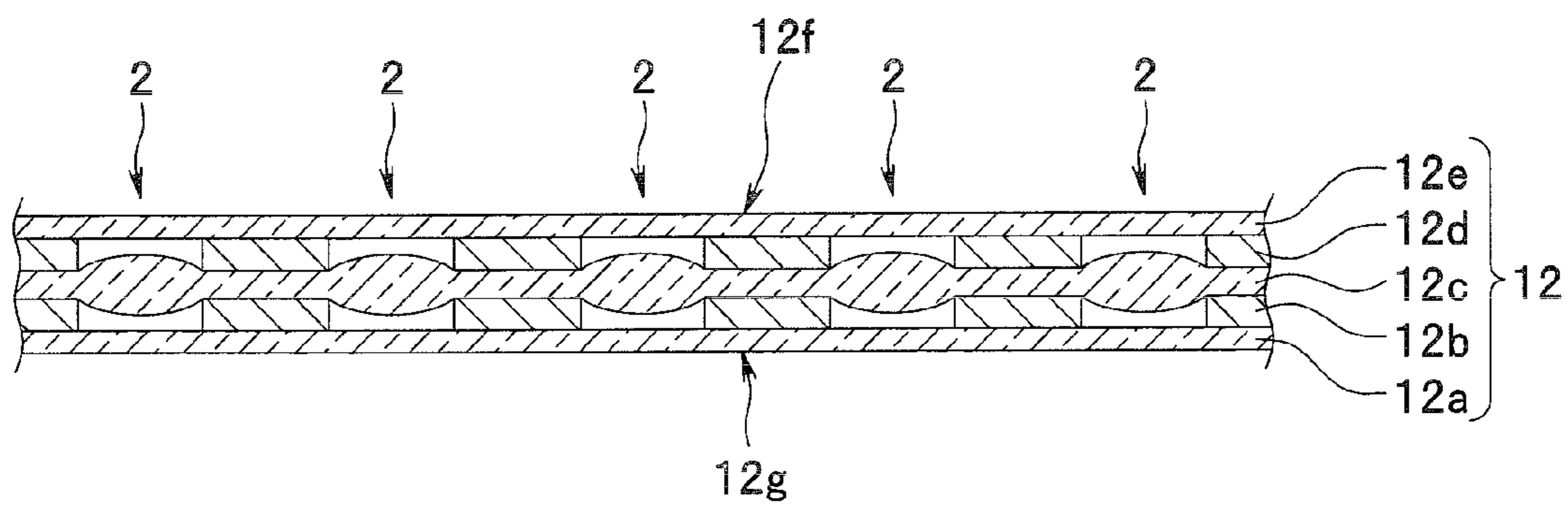

FIG. 11

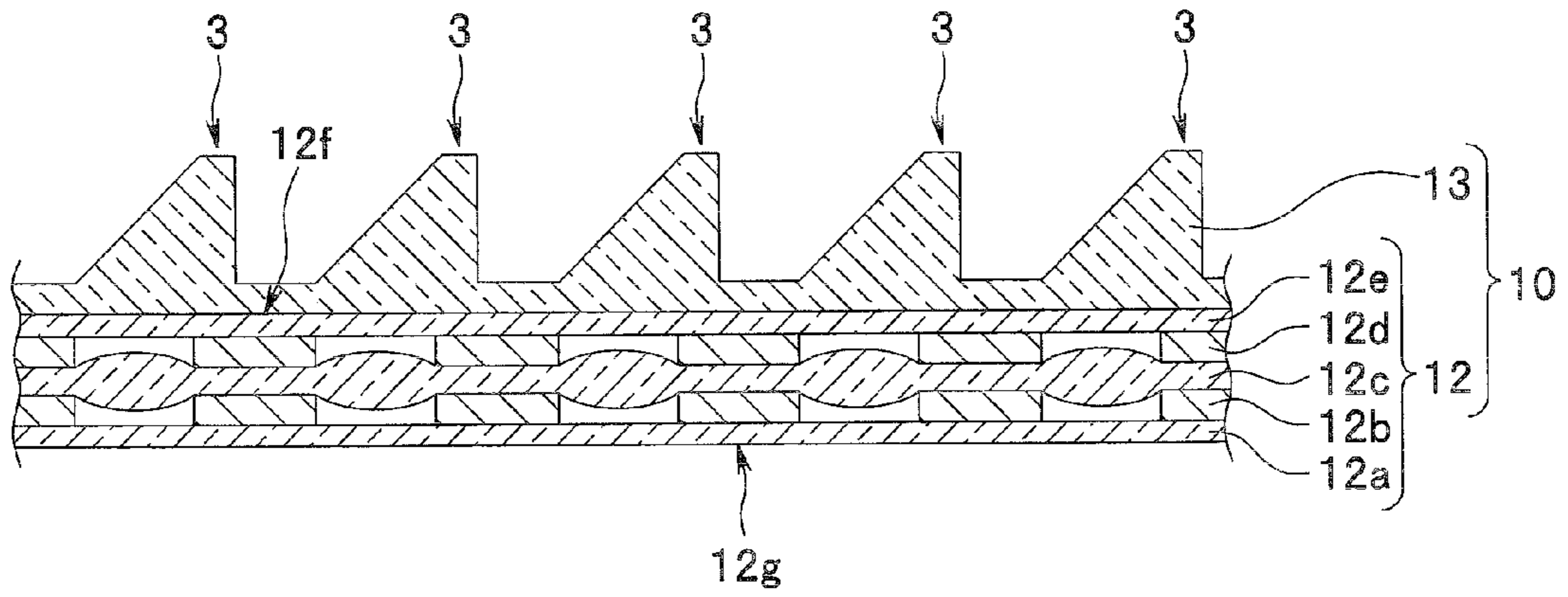

FIG. 12

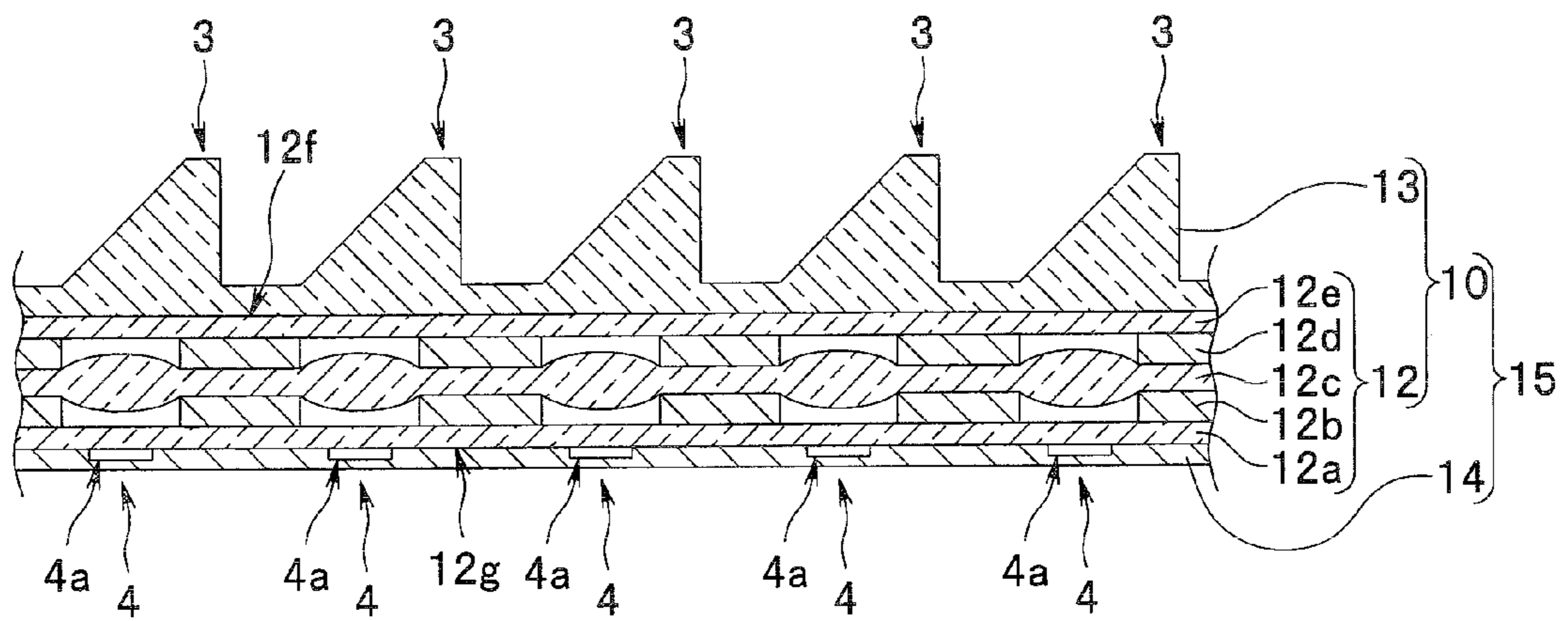

FIG. 13

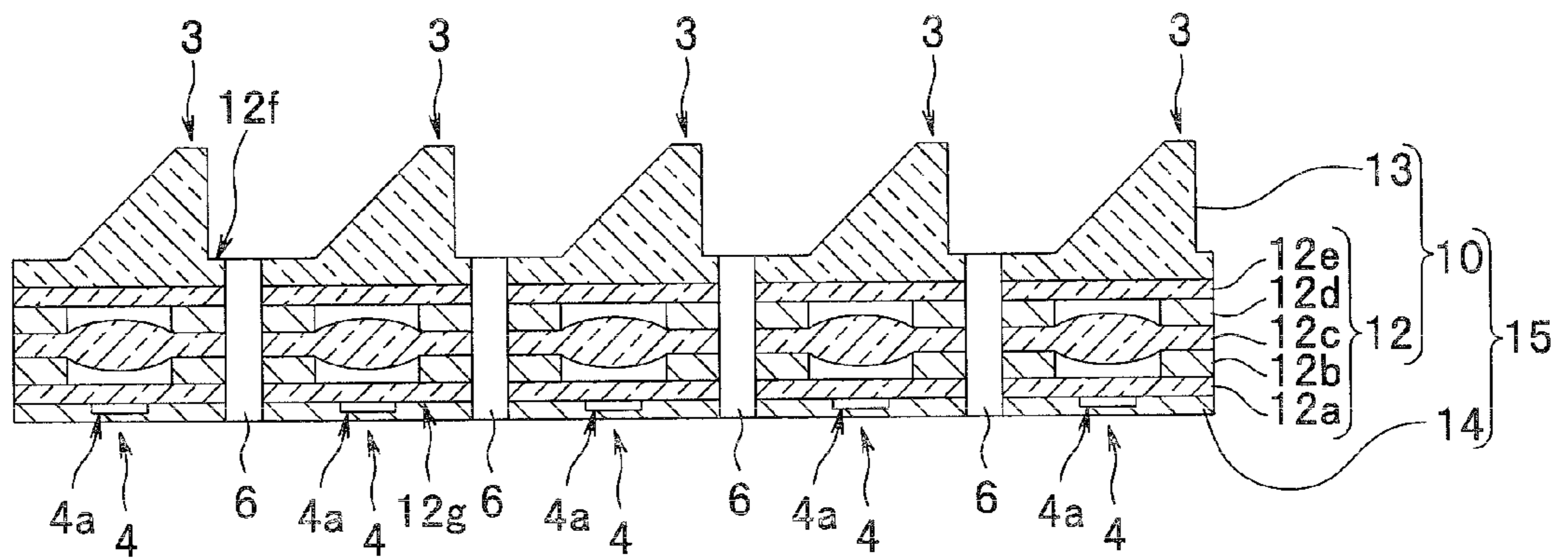

FIG. 14

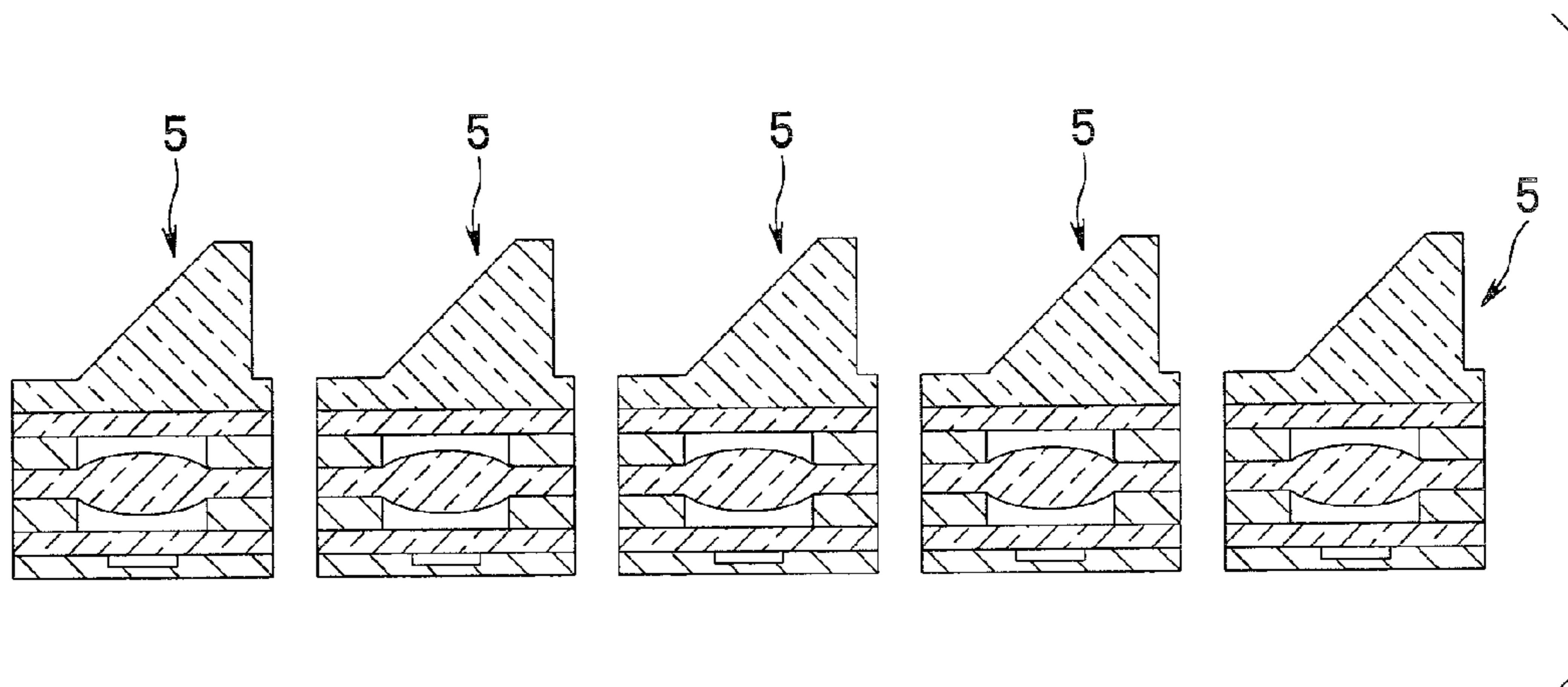

FIG. 15

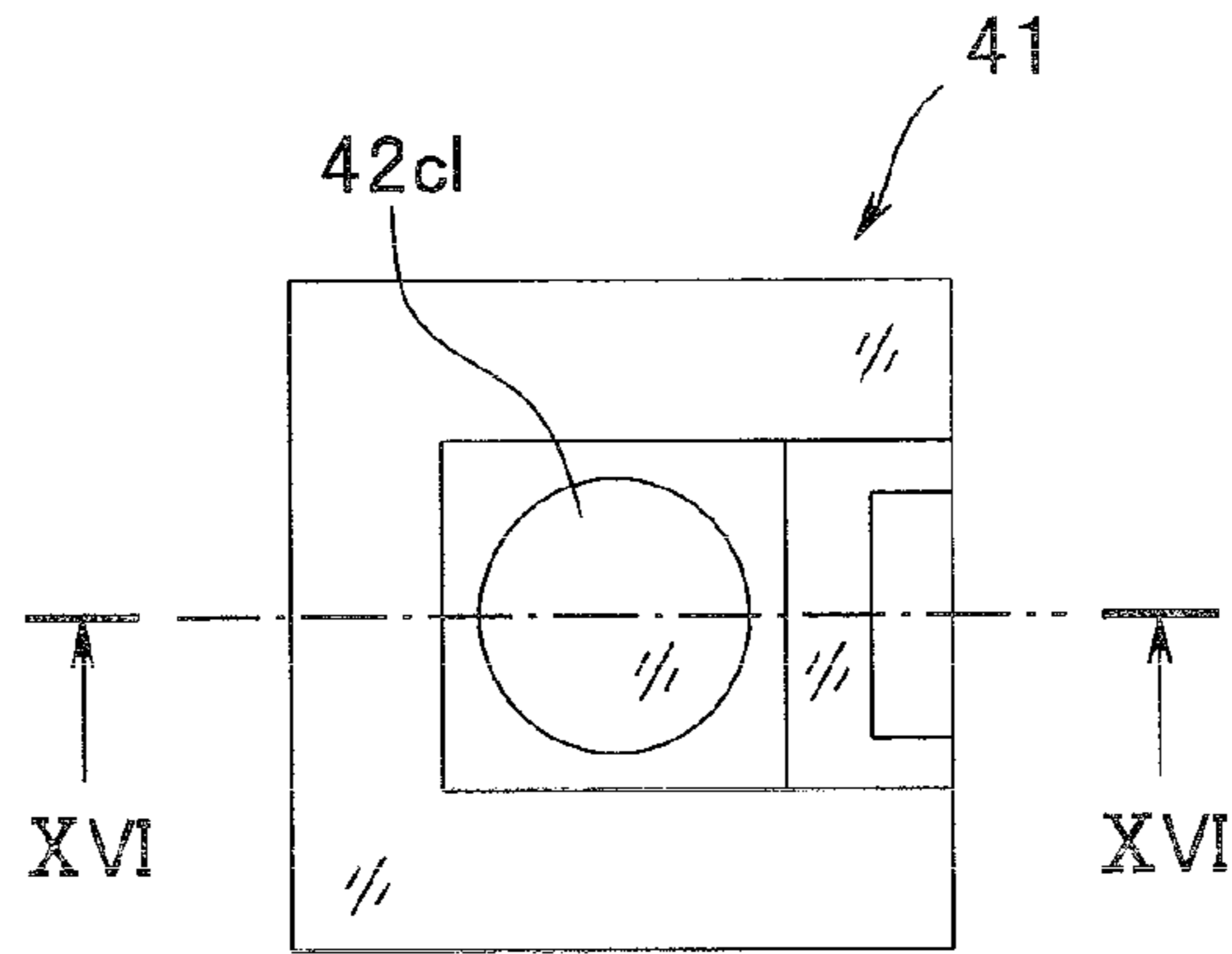

FIG. 16

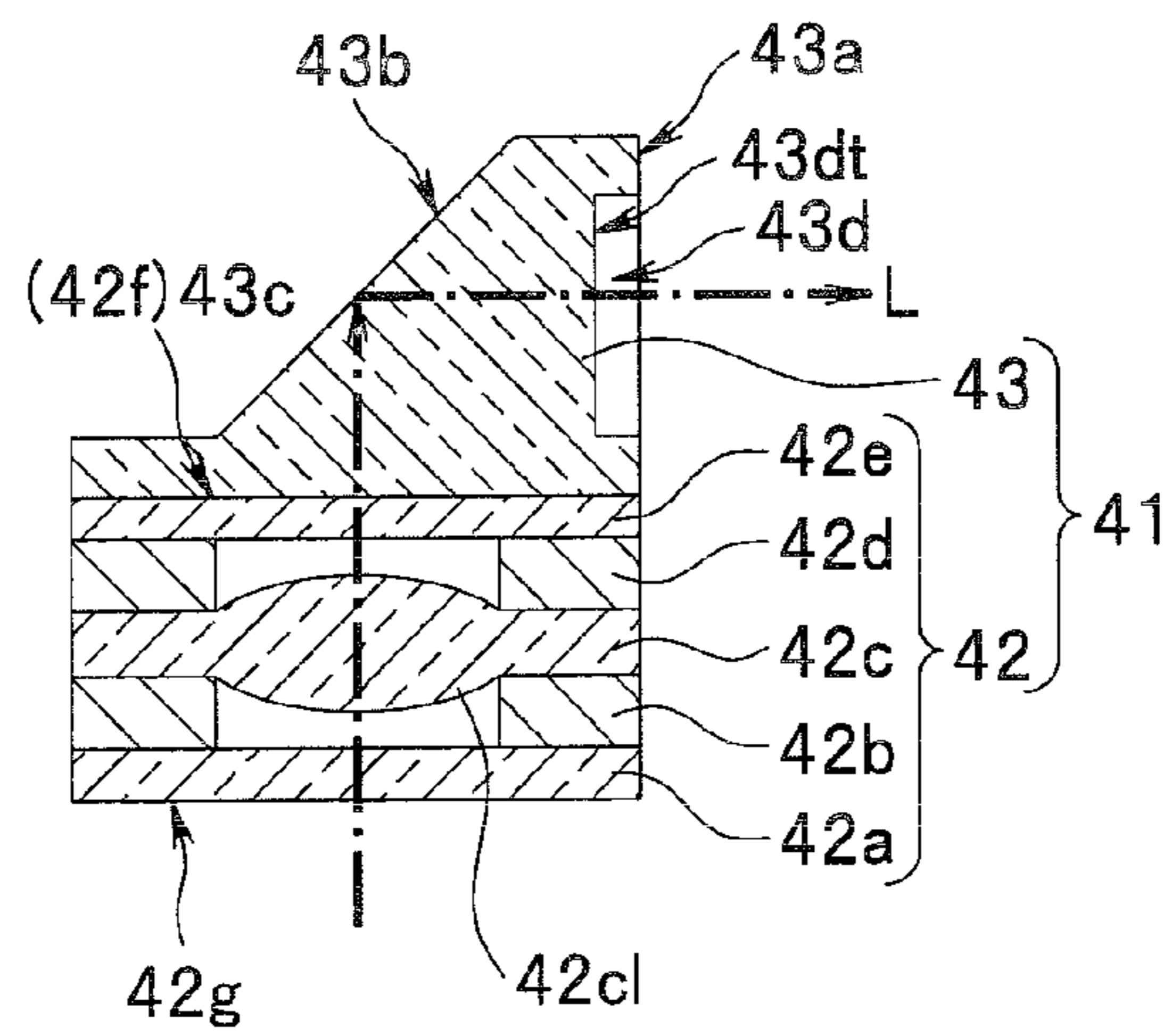

FIG.17

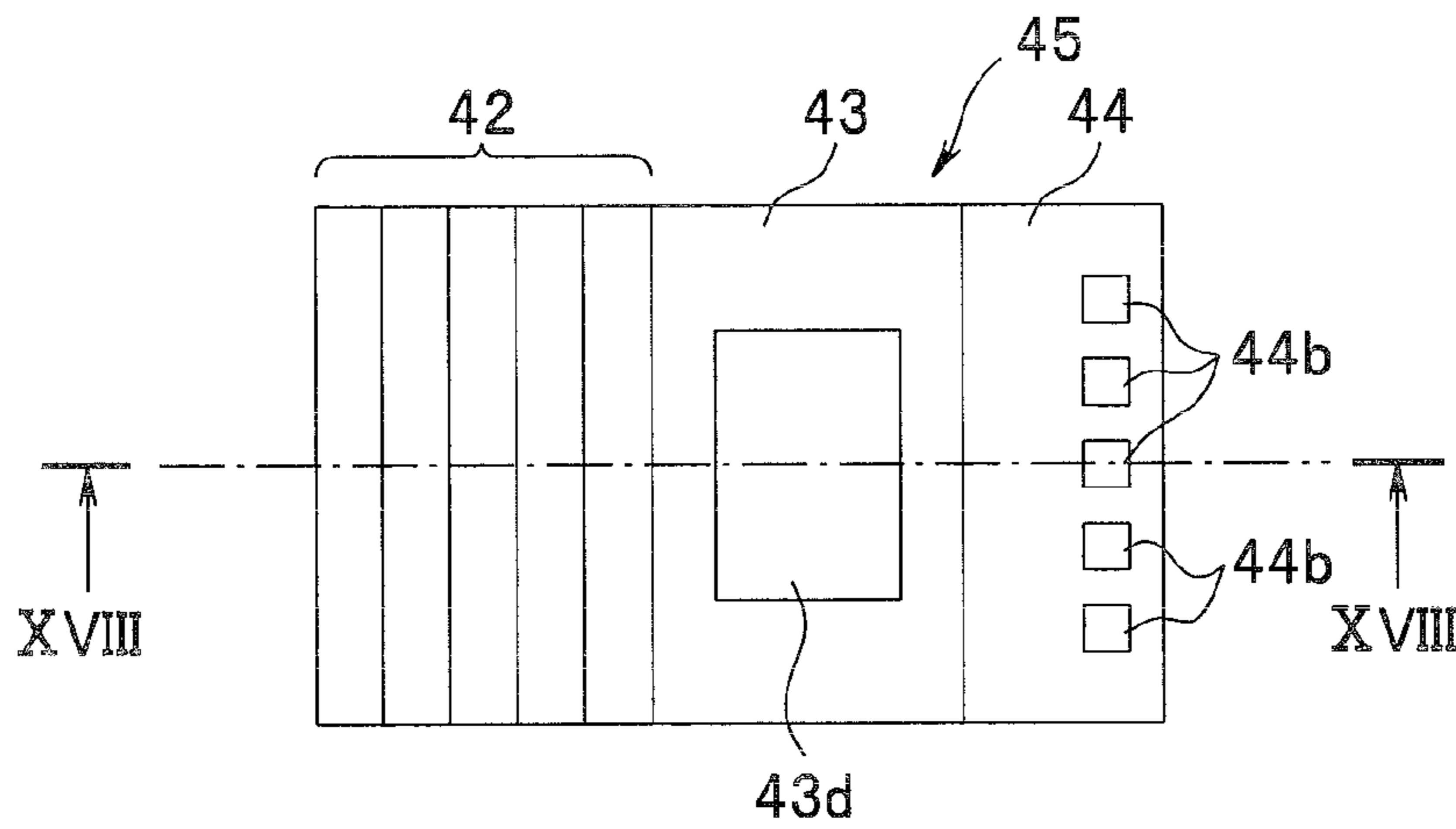

FIG.18

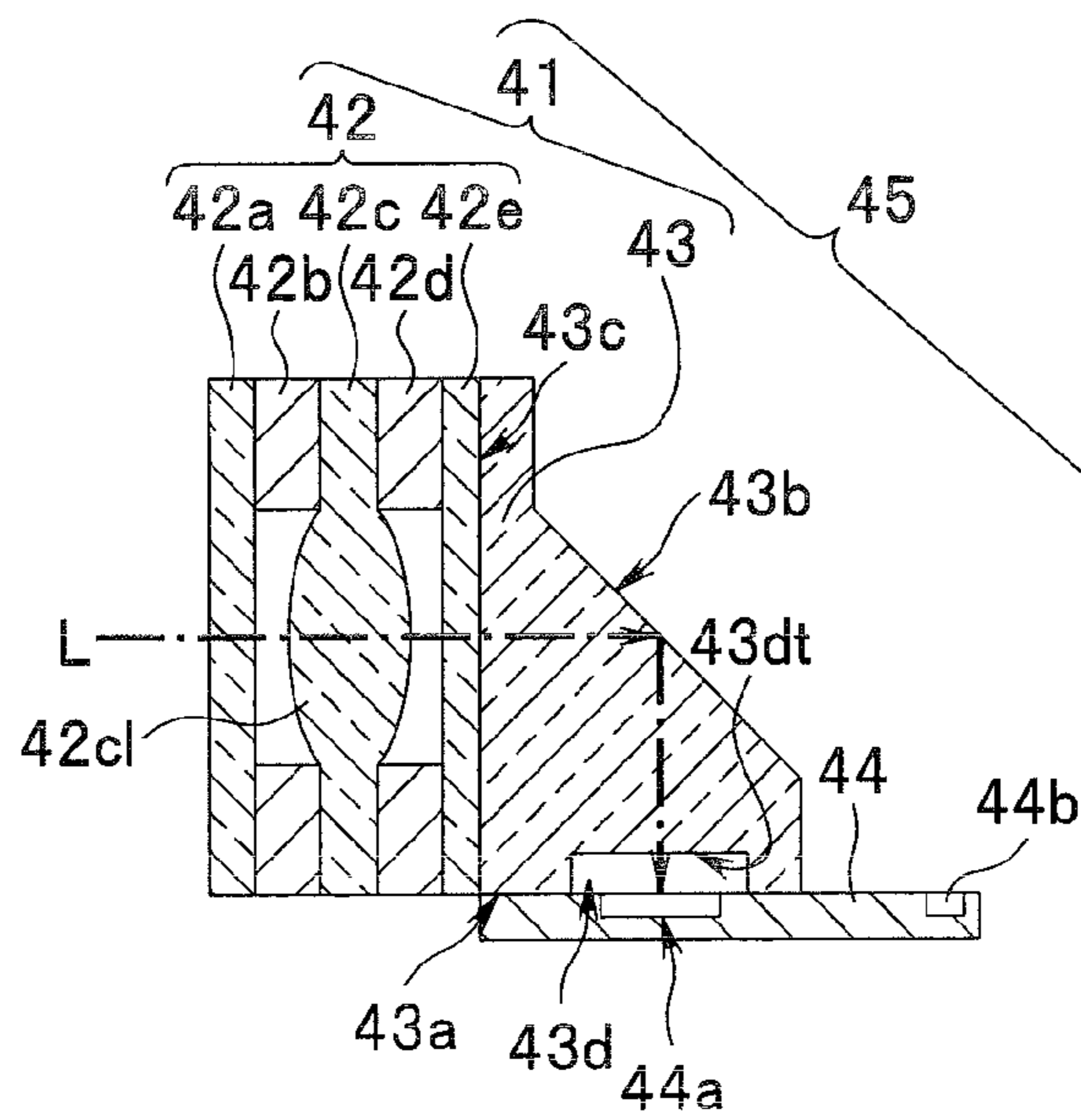

FIG. 19

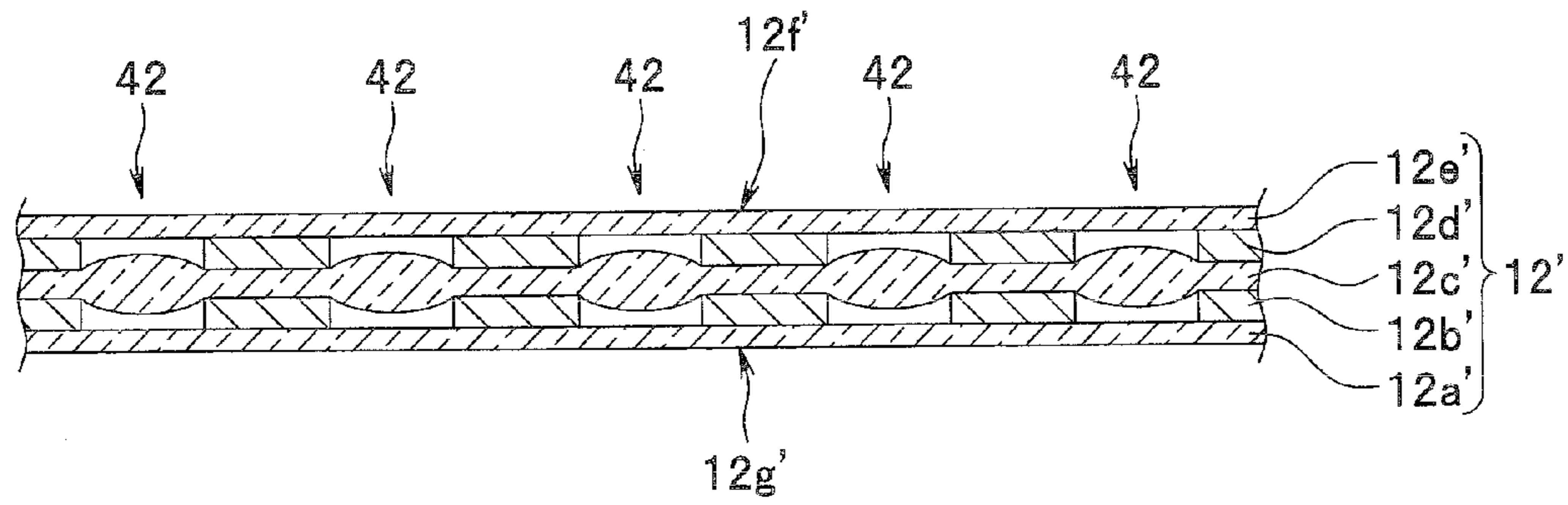

FIG. 20

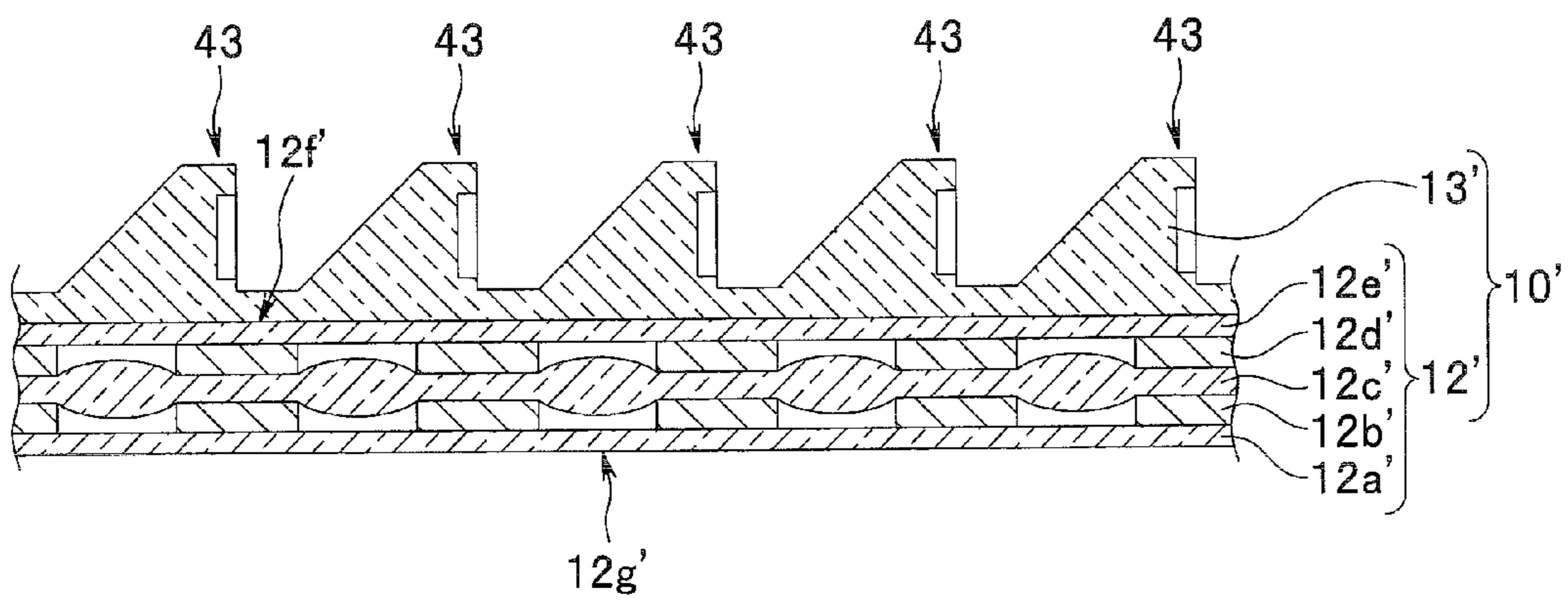

FIG. 21

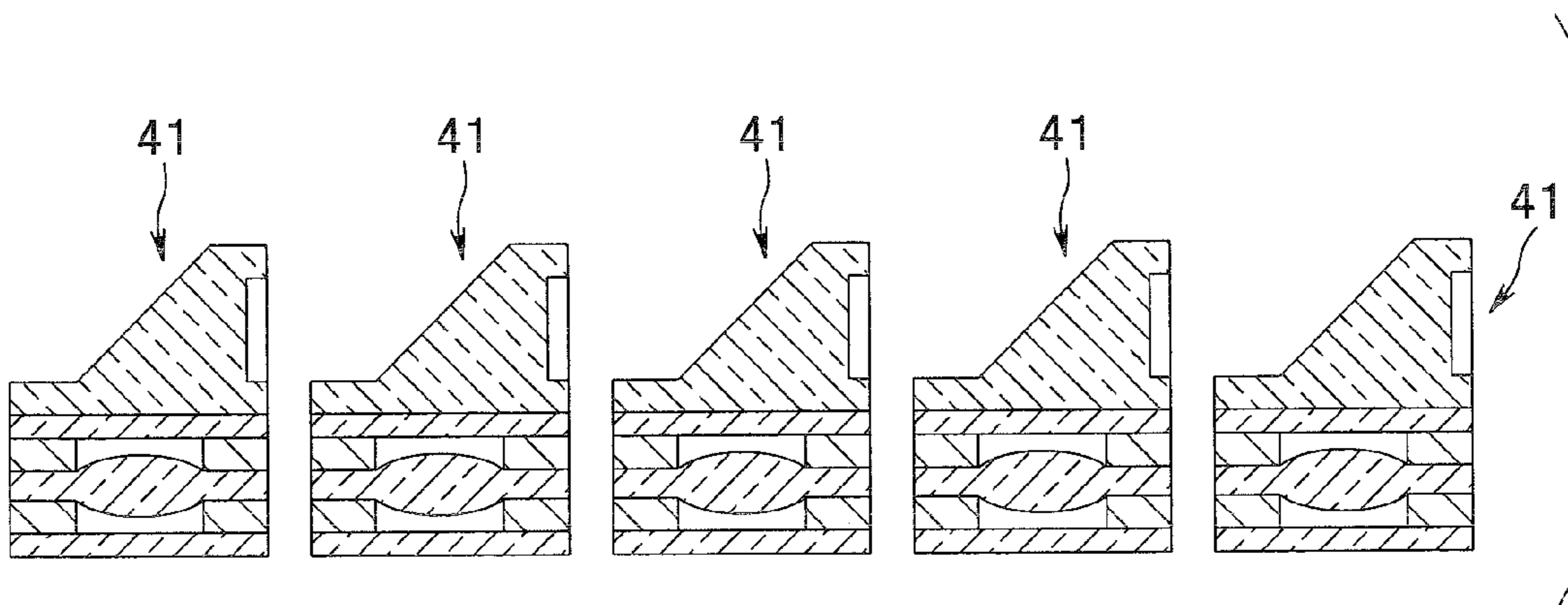

FIG. 22

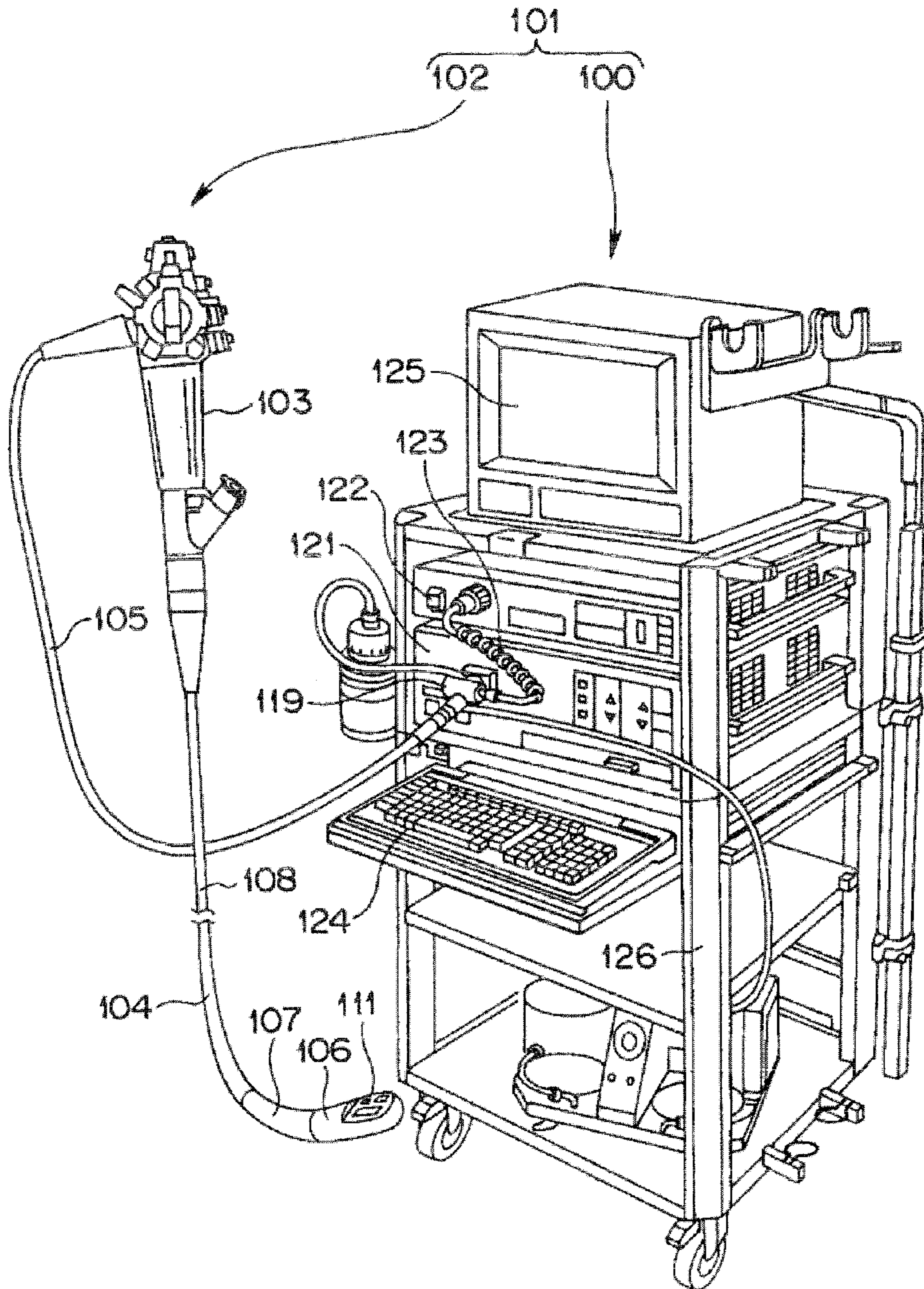

FIG.23

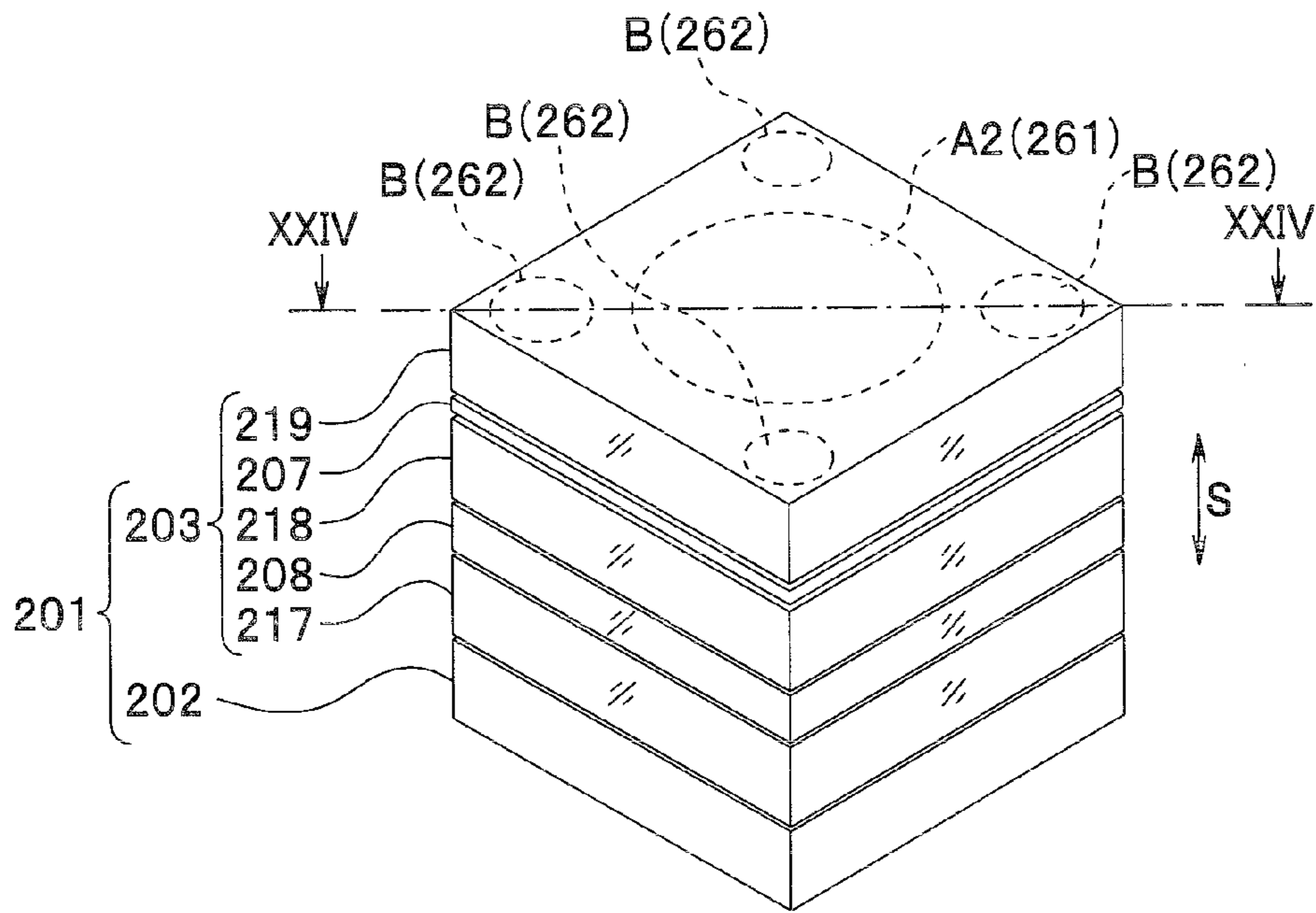

FIG.24

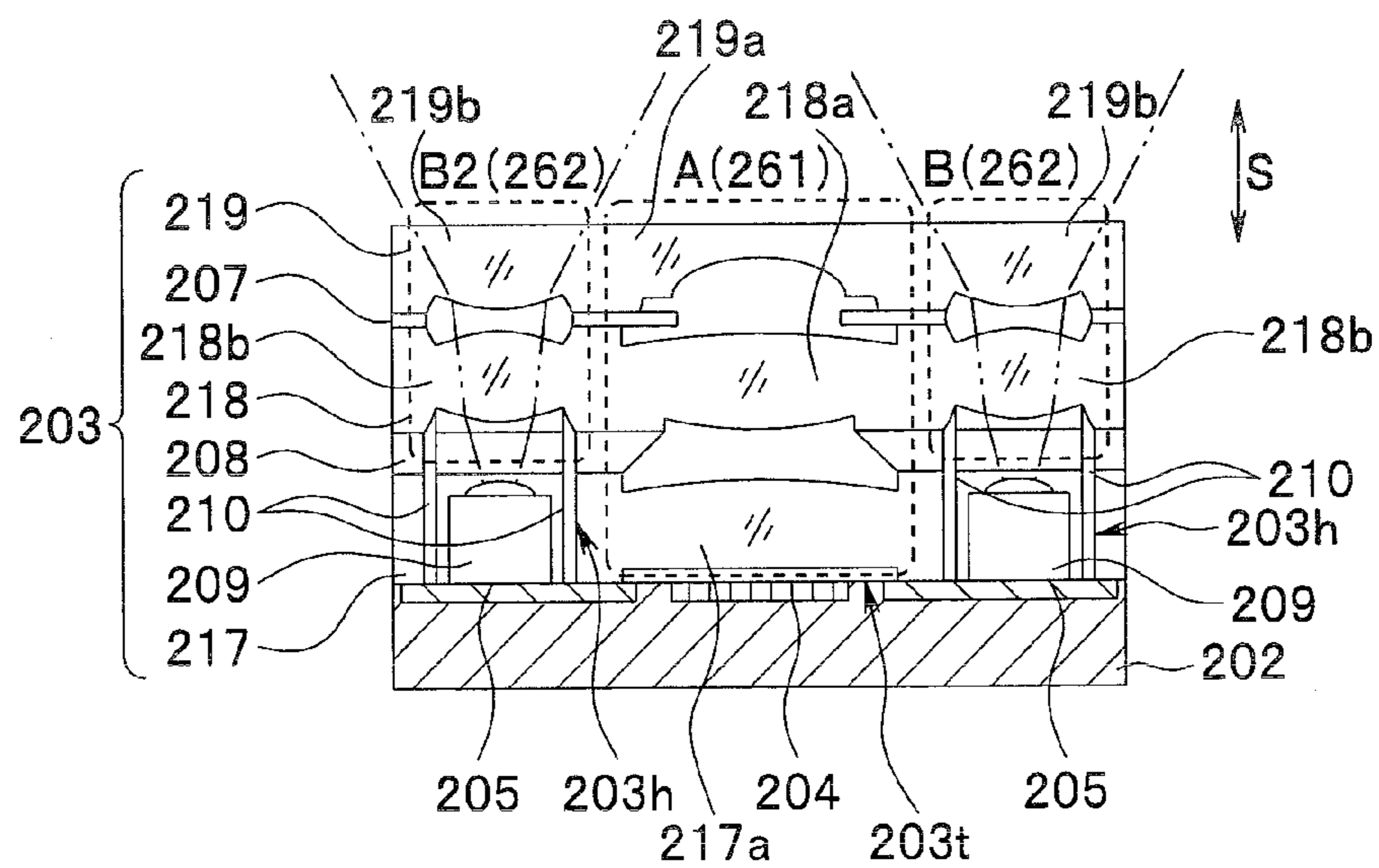

IMAGE PICKUP UNIT, OPTICAL UNIT, AND MANUFACTURING METHOD FOR THE IMAGE PICKUP UNIT

CROSS REFERENCE TO RELATED APPLICATION

This application claims the benefit of Japanese Applications No. 2008-262070 filed in Japan on Oct. 8, 2008 and No. 2008-264503 filed in Japan on Oct. 10, 2008, the contents of which are incorporated herein by this reference.

BACKGROUND OF THE INVENTION

1. Field of the Invention

The present invention relates to an image pickup unit, an optical unit, and a manufacturing method for the image pickup unit.

2. Description of the Related Art

An electronic endoscope, a cellular phone with camera, a digital camera, and the like including an image pickup unit provided with a solid-state image pickup device such as a CCD or a CMOS are being widely spread.

A main section of the image pickup unit includes the solid-state image pickup device and an optical unit including a lens for making an optical image of a subject incident on a light receiving section of the solid-state image pickup device. In the cellular phone with camera and the digital camera reduced in size and thickness or the electronic endoscope adapted to view sideways and reduced in diameter of an insertion section, for the purpose of, for example, bending an optical axis or realizing a reduction in thickness of the image pickup unit, the optical unit further includes a bending optical element such as a prism. The image pickup unit in which the optical unit includes the bending optical element is disclosed in, for example, Japanese Utility Model Laid-Open No. Hei 7-24088.

As shown in FIG. 1, a main section of an image pickup unit **65** disclosed in Japanese Utility Model Laid-Open No. Hei 7-24088 includes an optical unit **68** and a solid-state image pickup device **64**. A main section of the optical unit **68** includes a lens unit **62** and a prism **63**. A main section of the lens unit **62** includes a lens barrel **62c**, a first lens unit **62a** and a second lens unit **62b** including plural lenses provided in the lens barrel **62c**, and a coupling frame **62d** fit in an outer circumference on a rear end side in an optical axis direction of the lens barrel **62c**.

An incident surface **63a** of the prism **63** is bonded and fixed to a rear end in the optical axis direction of the coupling frame **62d**. The solid-state image pickup device **64** is fixed to an emission surface **63c** of the prism **63**.

In the image pickup unit **65** having such a configuration, adjustment of an angle of deviation and centering of an optical system in the optical unit **68** can be realized by alignment adjustment of the two lens units **62a** and **62b**, the prism **63**, and the solid-state image pickup device **64**.

However, in the image pickup unit disclosed in Japanese Utility Model Laid-Open No. Hei 7-24088, when the optical unit **68** and the image pickup unit **65** are manufactured, after the prism **63** and the lens unit **62** are separately formed, the prism **63** is bonded to a rear end portion of the coupling frame **62d** of the lens unit **62**. Since work for adjusting the angle of deviation and the centering of the optical system in the optical unit **68** is difficult and takes long time, the work causes an increase in cost. There is a demand for a manufacturing method that can manufacture a large number of optical units and image pickup units at a time at low cost.

On the other hand, a main section of the image pickup unit includes the solid-state image pickup device and an optical unit including a lens for making an optical image of a subject incident on a light receiving section of the solid-state image pickup device. In recent years, as the optical unit, an optical unit in which optical components are laminated in plural layers is well known. The optical unit is formed by slicing an optical unit wafer after bonding plural lens wafers, which form the optical components such as a lens, a stop, and a spacer, and forming the optical unit wafer.

As the image pickup unit, an image pickup unit is well known which is formed by slicing an image pickup unit wafer after bonding plural lens wafers, which form the optical components such as a lens, a stop, and a spacer, and forming an optical unit wafer and further bonding a sensor wafer including a solid-state image pickup device to the optical unit wafer and forming the image pickup unit wafer.

For example, Japanese Patent Application Laid-Open Publication No. 2004-29554 discloses an image pickup unit **224** formed by, as shown in FIG. 2, bonding an image pickup device **223** to a bottom surface of an optical unit **222** formed by laminating lenses **222a** to **222c** as optical components in plural layers to have spaces in an optical axis direction in a part between the lenses **222a** and **222b** and between the lenses **222b** and **222c**.

In the optical unit **222** shown in FIG. 2, the optical unit **222** is formed by cutting an optical unit wafer by dicing or the like after bonding a lens wafer including the lens **222a**, a lens wafer including the lens **222b**, and a lens wafer including the lens **222c** and forming the optical unit wafer. As an external shape of the optical unit **222**, as shown in FIG. 2, a planar shape viewed from above is often a square shape or a polygonal shape because of a limitation in a processing method.

In the optical unit **222** disclosed in Japanese Patent Application Laid-Open Publication No. 2004-29554, an area functioning as an optical lens, i.e., an area functioning to focus an optical image of a subject on the image pickup device **223** in the optical unit **222**, in other words, an area through which a light beam from the subject passes is set to a dimension equal to or smaller than a dimension of a circle **C** inscribed in a square forming an external shape of the optical unit **222** as shown in FIG. 2 in a state of plan view from above.

Therefore, as explained above, since the external shape of the optical unit **222** is formed in the square shape or the like because of the limitation in the processing method, as shown in FIG. 2, an area **D** as an outer circumferential area of the circle **C** is an optically ineffective area in the state of plan view from above. Therefore, a useless area is formed in the optical unit **222**.

As shown in FIGS. 3 and 4, in general, in an insertion section distal end **231** of an endoscope, besides an image pickup unit **234**, a light guide **235** for illumination, a treatment instrument inserting-through channel **236**, and the like are provided around the image pickup unit **234**. As shown in FIG. 4, an external dimension of the insertion section distal end **231** of the endoscope is determined by an external shape of the image pickup unit **234** itself and an external shape of the light guide **235** for illumination and the treatment instrument inserting-through channel **236**. However, even in this case, if an optically ineffective area **E** is formed in the image pickup unit **234**, the external shape of the image pickup unit **234** is increased in size. Therefore, the insertion section distal end **231** of the endoscope is increased in diameter. This may be a cause of pain for a patient.

SUMMARY OF THE INVENTION

A manufacturing method for an image pickup unit according to an embodiment of the present invention includes: a step

3

of bonding plural lens wafers, on which optical components are formed, and forming a lens unit wafer including plural lens units; a step of bonding a bending optical element wafer including plural bending optical elements to a first surface of the lens unit wafer such that the plural bending optical elements are respectively opposed to the plural lens units and forming an optical unit wafer; a step of bonding a sensor wafer including plural solid-state image pickup devices to a second surface opposed to the first surface of the lens unit wafer in the optical unit wafer such that the plural solid-state image pickup devices are respectively opposed to the plural lens units and forming an image pickup unit wafer; and a step of separating and individualizing the image pickup unit wafer for each of the lens units, the bending optical elements, and the solid-state image pickup devices and manufacturing plural image pickup units.

An optical unit including a laminated body according to another embodiment of the present invention includes: an image pickup optical section formed to have, in a state of plan view from above of the laminated body formed by bonding plural optical components, an image pickup lens along a laminating direction of the optical components in a first area of the laminated body; and an illumination optical section formed to have, in the state of plan view from above of the laminated body, an illumination lens along the laminating direction in a second area set to avoid the image pickup optical section.

An image pickup unit including an optical unit and an image pickup device mounted with the optical unit according to still another embodiment of the present invention includes: an image pickup optical section formed to have, in a state of plan view from above of the optical unit including a laminated body formed by bonding plural optical components, an image pickup lens along a laminating direction of the optical components in a first area of the optical unit; an illumination optical section formed to have, in the state of plan view from above of the optical unit, an illumination lens along the laminating direction in a second area set to avoid the image pickup optical section; a first recess drilled along the laminating direction from a bottom surface of the optical unit in the second area of the optical unit; and the image pickup device having an image pickup section and a first peripheral circuit section, in which a light emitting element is provided, and bonded to the bottom surface of the optical unit such that the image pickup section is located in the first area, the first peripheral circuit section and the light emitting element are located in the second area, and the light emitting element is located in the first recess.

BRIEF DESCRIPTION OF THE DRAWINGS

FIG. 1 is a schematic partial sectional view of a configuration of a conventional image pickup unit;

FIG. 2 is a schematic perspective view of the configuration of the conventional image pickup unit;

FIG. 3 is a schematic partial sectional view of a configuration of an insertion section distal end side in a state in which the conventional image pickup unit is provided at a distal end of an insertion section of an endoscope;

FIG. 4 is a plan view of FIG. 3 viewed from an X direction;

FIG. 5 is a top view of an optical unit according to a first embodiment of the present invention;

FIG. 6 is a sectional view of the optical unit taken along VI-VI line in FIG. 5;

FIG. 7 is a sectional view of a configuration of a modification of the optical unit shown in FIG. 6;

4

FIG. 8 is a top view of an image pickup unit according to the first embodiment;

FIG. 9 is a sectional view of the image pickup unit taken along IX-IX line in FIG. 8;

FIG. 10 is a partial sectional view of a lens unit wafer;

FIG. 11 is a partial sectional view of a state in which a bending optical element wafer is bonded to a first surface of the lens unit wafer shown in FIG. 10 to form an optical unit wafer;

FIG. 12 is a partial sectional view of a state in which a sensor wafer is bonded to a second surface of the lens unit wafer shown in FIG. 11 to form an image pickup unit wafer;

FIG. 13 is a partial sectional view of a state in which dicing lines are formed for respective lens units on the image pickup unit wafer shown in FIG. 12;

FIG. 14 is a partial sectional view of a state in which plural image pickup units are individualized from the image pickup unit wafer starting from the dicing lines shown in FIG. 13;

FIG. 15 is a top view of an optical unit according to a second embodiment of the present invention;

FIG. 16 is a sectional view of the optical unit taken along XVI-XVI line in FIG. 15;

FIG. 17 is a top view of an image pickup unit according to the second embodiment;

FIG. 18 is a sectional view of the image pickup unit taken along XVIII-XVIII line in FIG. 17;

FIG. 19 is a partial sectional view of a lens unit wafer;

FIG. 20 is a partial sectional view of a state in which a bending optical element wafer is bonded to a first surface of the lens unit wafer shown in FIG. 19 to form an optical unit wafer;

FIG. 21 is a partial sectional view of a state in which plural optical units are individualized from the optical unit wafer shown in FIG. 20;

FIG. 22 is a perspective view of an endoscope apparatus including an endoscope provided with an optical unit or an image pickup unit;

FIG. 23 is a perspective view of an image pickup unit according to a third embodiment of the present invention;

FIG. 24 is a sectional view of the image pickup unit taken along XXIV-XXIV line in FIG. 23;

FIG. 25 is a sectional view of an image pickup unit according to a fourth embodiment of the present invention;

FIG. 26 is an enlarged perspective view of a flat plate shown in FIG. 25;

FIG. 27 is a sectional view of an image pickup unit according to a fifth embodiment of the present invention; and

FIG. 28 is a sectional view of a configuration of a modification of the image pickup unit according to the fifth embodiment.

DETAILED DESCRIPTION OF THE PREFERRED EMBODIMENTS

Embodiments of the present invention are explained below with reference to the accompanying drawings. (First Embodiment)

First, a configuration of an optical unit manufactured by a manufacturing method for an optical unit according to a first embodiment of the present invention is explained with reference to FIGS. 5 and 6. As shown in FIGS. 5 and 6, a main section of an optical unit 1 includes a lens unit 2 and a bending optical element 3.

The lens unit 2 forms an optical image emitted from the bending optical element 3 on a solid-state image pickup device 4 (see FIG. 9) explained later. A main section of the lens unit 2 includes a flat plate 2a formed of a transparent

5

member, a spacer **2b** superimposed on the flat plate **2a** and having a through hole formed in an optical path of light beam L of the optical image, a lens member **2c** superimposed on the spacer **2b** and having a convex convex lens **2cl** located in the optical path of the light beam L, a stop **2d** superimposed on the lens member **2c** and having a through hole formed in the optical path of the light beam L, and a flat plate **2e** superimposed on the stop **2d** and formed of a transparent member. In other words, the lens unit **2** is formed by laminating the plural optical members (**2a** to **2e**). The lens unit **2** may include not only one convex convex lens **2cl** but also plural lenses.

A first surface **2f** of the lens unit **2** forms an incident surface of the light beam L on the lens unit **2**. A second surface **2g** opposed to the first surface **2f** of the lens unit **2** forms an emission surface of the light beam L from the lens unit **2**. The stop **2d** may be located between the flat plate **2a** and the lens member **2c** instead of the spacer **2b**. The spacer **2b** may be located between the lens member **2c** and the flat plate **2e** instead of the stop **2d**. The entire flat plates **2a** and **2e** do not need to be formed of the transparent members. Only the optical paths of the light beam L have to be formed of the transparent members.

The bending optical element **3** includes, for example, a prism. The bending optical element **3** is provided by bonding the emission surface **3c** to an outer surface of the flat plate **2e** serving as the first surface **2f** of the lens unit **2**. The bending optical element **3** may include not only the prism but also a reflecting mirror and the like.

The bending optical element **3** refracts, on an inclined plane **3b**, the light beam L of the optical image made incident from an incident surface **3a**, i.e., changes a direction of the light beam L on the inclined plane **3b** and makes the light beam L incident on the lens unit **2** from the emission surface **3c**.

As shown in FIG. 7, the inclined plane **3b** may be formed as a curved surface **3b'**. In this case, since the curved surface **3b'** functions as a convex lens, as shown in FIG. 7, a lens of the lens member **2c** of the lens unit **2** may be a plano-convex lens **2cl'** rather than the convex convex lens **2cl**. Therefore, a material of the lens member **2c** can be reduced from that in the configuration shown in FIG. 6.

In the optical unit **1** having such a configuration, incident light beam L from a subject image is made incident on the bending optical element **3** from the incident surface **3a** of the bending optical element **3**, refracted on the inclined plane **3b** or the curved surface **3b'**, and then emitted from the emission surface **3c**. The light beam L emitted from the emission surface **3c** is made incident on the lens unit **2** from the first surface **2f** of the lens unit **2** and emitted to the solid-state image pickup device **4** explained later from the second surface **2g**.

A configuration of an image pickup unit manufactured by a manufacturing method for an image pickup unit according to the present embodiment is explained with reference to FIGS. 8 and 9. As shown in FIGS. 8 and 9, a main section of an image pickup unit **5** includes the optical unit **1** and the solid-state image pickup device **4**. A configuration of the optical unit **1** is the same as the configuration shown in FIGS. 5 to 7. Therefore, explanation of the configuration is omitted.

The solid-state image pickup device **4** is provided to be bonded to the second surface **2g** of the lens unit **2**, specifically, an outer surface of the flat plate **2a** in a position where a light receiving section **4a** receives the light beam L emitted from the second surface **2g** of the lens unit **2**.

The solid-state image pickup device **4** receives, in the light receiving section **4a**, an optical image formed via the bending optical element **3** and the lens unit **2** and performs exchange

6

of a video signal with an external device via a wire piercing through a not-shown substrate that fixes the solid-state image pickup device **4**.

Manufacturing methods for the optical unit **1** and the image pickup unit **5** shown in FIGS. 5 to 9 are explained with reference to FIGS. 10 to 14.

First, as shown in FIG. 10, plural lens wafers on which optical components are formed are bonded to form a lens unit wafer **12** including a plurality of the lens units **2**. Specifically, first, the lens unit wafer **12** is formed by superimposing and bonding a lens wafer **12b** including a plurality of the spacers **2b** on a lens wafer **12a** including a plurality of the flat plates **2a**, superimposing and bonding a lens wafer **12c** including a plurality of the lens members **2c** on the lens wafer **12b**, superimposing and bonding a lens wafer **12d** including a plurality of the stops **2d** on the lens wafer **12c**, and superimposing and bonding a lens wafer **12e** including a plurality of the flat plates **2e** on the lens wafer **12d**. As a result, a plurality of the lens units **2** including the flat plates **2a**, the spacers **2b**, the lens members **2c**, the stops **2d**, and the flat plates **2e** are formed on the lens unit wafer **12**.

The lens wafers **12a** to **12d** are bonded such that transparent sections of the flat plates **2a** and **2e**, the through holes of the spacers **2b** and the stops **2d**, and the convex convex lenses **2cl** of the lens members **2c** are respectively located on optical axes of light beams L.

Subsequently, as shown in FIG. 11, a bending optical element wafer **13** including a plurality of the bending optical elements **3** is bonded to the first surface **12f** forming an incident surface of the light beam L of the lens unit wafer **12**, specifically, an outer surface of the lens wafer **12e** such that the bending optical elements **3** are respectively opposed to the lens units **2** and emission surfaces **3c** of the bending optical elements **3** are set in contact with the lens units **2**. An optical unit wafer **10** including a plurality of the optical units **1** is formed.

In this state, although not shown in the figure, if the optical unit wafer **10** is separated and individualized for each of the lens units **2**, i.e., for each of the optical units **1** and the bending optical elements **3**, a plurality of the optical units **1** shown in FIGS. 5 and 6 are manufactured.

When the image pickup unit **5** is manufactured, as shown in FIG. 12, a sensor wafer **14** including a plurality of the solid-state image pickup devices **4** is bonded to the second surface **12g** forming an emission surface of the light beam L opposed to the first surface **12f** of the lens unit wafer **12** in the optical unit wafer **10** shown in FIG. 11, specifically, an outer surface of the lens wafer **12a** such that the solid-state image pickup devices **4** are respectively opposed to the lens units **2**. An image pickup unit wafer **15** including a plurality of the image pickup units **5** including the optical units **1** and the solid-state image pickup devices **4** is formed.

Specifically, as shown in FIG. 12, the sensor wafer **14** is bonded to the second surface **12g** of the lens unit wafer **12** in positions where light receiving sections **4a** of the solid-state image pickup devices **4** receive the light beams L emitted from the lens units **2**.

Thereafter, as shown in FIG. 13, dicing lines **6** are formed in the image pickup unit wafer **15** respectively for the lens units **2** and the bending optical elements **3** and the solid-state image pickup devices **4**, i.e., the image pickup units **5**. As shown in FIG. 14, the image pickup unit wafer **15** is separated and individualized on the basis of the dicing lines **6**. Then, a plurality of the image pickup units **5** shown in FIGS. 8 and 9 are manufactured.

In this way, in the present embodiment, the plural optical units **1** are manufactured by bonding the plural lens wafers

12a to 12e, on which the optical components are formed, and forming the lens unit wafer 12 including the plural lens unit 2, bonding the bending optical element wafer 13 including the plural bending optical elements 3 to the first surface 12f of the lens unit wafer 12 and forming the optical unit wafer 10, and individualizing the optical unit wafer 10.

The plural image pickup units 5 are manufactured by bonding the sensor wafer 14 including the plural solid-state image pickup devices 4 to the second surface 12g in the lens unit wafer 12 of the optical unit wafer 10 and forming the image pickup unit wafer 15 and individualizing the image pickup unit wafer 15.

Consequently, the optical unit 1 shown in FIGS. 5 and 6 or the image pickup unit 5 shown in FIGS. 8 and 9 is formed at a wafer level. Therefore, focus adjustlessness can be realized by adjusting and managing the thicknesses of the wafers that form the optical units 1 or the image pickup units 5.

Accurate alignment adjustment can be easily performed by using a wafer process. Therefore, work for adjusting an angle of deviation and centering of an optical system in the optical unit 1 is substantially reduced. A large number of optical units 1 or the image pickup units 5 can be collectively manufactured. Consequently, high yield and low cost can be realized.

As explained in a second embodiment of the present invention later, a recess or an opening (both of which are not shown in the figure) is formed in a position opposed to the light receiving section 4a of the solid-state image pickup device 4 on the second surface 2g of the lens unit 2 of the optical unit 1. Then, the image pickup unit 5 can be manufactured without spoiling a microlens effect of the solid-state image pickup device 4.

Consequently, it is possible to provide the manufacturing method for the optical unit 1 and the manufacturing method for the image pickup unit 5 that can reduce work for adjusting an angle of deviation and centering of the optical system in the optical unit 1 and efficiently manufacture the optical unit 1 and the image pickup unit 5 as well as the optical unit 1 and the image pickup unit 5.

(Second Embodiment)

An optical unit and an image pickup unit according to a second embodiment of the present invention are explained below. Configurations of the optical unit and the image pickup unit according to the present embodiment are different from those of the optical unit and the image pickup unit according to the first embodiment in that a direction of light made incident on the optical unit is opposite and the solid-state image pickup device is bonded to the emission surface of the bending optical element. Therefore, only these differences are explained. Components same as those in the first embodiment are denoted by the same reference numerals and signs and explanation of the components is omitted.

First, a configuration of an optical unit manufactured by a manufacturing method for an optical unit according to the present embodiment is explained with reference to FIGS. 15 and 16. As shown in FIGS. 15 and 16, a main section of an optical unit 41 includes a lens unit 42 and a bending optical element 43.

The lens unit 42 forms an optical image on a solid-state image pickup device 44 (see FIG. 18) explained later via the bending optical element 43. A main section of the lens unit 42 includes a flat plate 42a formed of a transparent member, a spacer 42b superimposed on the flat plate 42a and having a through hole formed in an optical path of light beam L of the optical image, a lens member 42c superimposed on the spacer 42b and having a convex lens 42cl located in the optical path of the light beam L, a stop 42d superimposed on the lens member 42c and having a through hole formed in the

optical path of the light beam L, and a flat plate 42e superimposed on the stop 42d and formed of a transparent member. In other words, the lens unit 42 is formed by laminating the plural optical members (42a to 42e). The lens unit 42 may include not only one lens 42cl but also plural lenses.

A first surface 42f of the lens unit 42 forms an emission surface of the light beam L from the lens unit 42. A second surface 42g opposed to the first surface 42f of the lens unit 42 forms an incident surface of the light beam L on the lens unit 42.

The stop 42d may be located between the flat plate 42a and the lens member 42c instead of the spacer 42b. The spacer 42b may be located between the lens member 42c and the flat plate 42e instead of the stop 42d. The entire flat plates 42a and 42e do not need to be formed of the transparent members. Only the optical paths of the light beam L have to be formed of the transparent members.

The bending optical element 43 includes, for example, a prism. The bending optical element 43 is provided by bonding an incident surface 43c to an outer surface of the flat plate 42e serving as the first surface 42f of the lens unit 42. The bending optical element 43 may include not only the prism but also a reflecting mirror and the like.

The bending optical element 43 refracts, on an inclined plane 43b, the light beam L of the optical image made incident from the first surface 42f of the lens unit 42, i.e., changes a direction of the light beam L on the inclined plane 43b and makes the light beam L incident on the solid-state image pickup device 44 from an emission surface 43a. The inclined plane 43b may be formed as a curved surface as shown in FIG. 7.

A recess 43d is formed in the emission surface 43a of the bending optical element 43. An optical surface 43dt is formed on a bottom surface of the recess 43d. The light beam L is also emitted from the optical surface 43dt.

In the optical unit 41 having such a configuration, incident light beam L from a subject image is made incident on the lens unit 42 from the second surface 42g, made incident on the bending optical element 43 from the first surface 42f via the incident surface 43c, refracted on the inclined plane 43b, and then emitted from the emission surface 43a. The light beam L emitted from the emission surface 43a is made incident on the solid-state image pickup device 44 explained later.

A configuration of an image pickup unit manufactured by a manufacturing method for an image pickup unit according to the present embodiment is explained with reference to FIGS. 17 and 18.

As shown in FIGS. 17 and 18, a main section of an image pickup unit 45 includes the optical unit 41 and the solid-state image pickup device 44. A configuration of the optical unit 41 is the same as the configuration shown in FIGS. 15 and 16. Therefore, explanation of the configuration is omitted.

The solid-state image pickup device 44 is provided to be bonded to the emission surface 43a of the bending optical element 43 after being aligned in a position where a space is formed between a light receiving section 44a and the optical surface 43dt and the light receiving section 44a receives the light beam L emitted from the optical surface 43dt.

The solid-state image pickup device 44 receives, in the light receiving section 44a, an optical image formed via the lens unit 42 and the bending optical element 43 and performs exchange of a video signal with an external device via a not-shown wire electrically connected to an electrode 44b of the solid-state image pickup device 44.

Manufacturing methods for the optical unit 41 and the image pickup unit 45 shown in FIGS. 15 to 18 are explained with reference to FIGS. 19 to 21.

First, as shown in FIG. 19, plural lens wafers on which optical components are formed are bonded to form a lens unit wafer 12' including a plurality of the lens units 42. Specifically, first, the lens unit wafer 12' is formed by superimposing and bonding a lens wafer 12b' including a plurality of the spacers 42b on a lens wafer 12a' including a plurality of the flat plates 42a, superimposing and bonding a lens wafer 12c' including a plurality of the lens members 42c on the lens wafer 12b', superimposing and bonding a lens wafer 12d' including a plurality of the stops 42d on the lens wafer 12c', and superimposing and bonding a lens wafer 12e' including a plurality of the flat plates 42e on the lens wafer 12d'. As a result, a plurality of the lens units 42 including the flat plates 42a, the spacers 42b, the lens members 42c, the stops 42d, and the flat plates 42e are formed on the lens unit wafer 12'.

The lens wafers 12a' to 12e' are bonded such that transparent sections of the flat plates 42a and 42e, the through holes of the spacers 42b and the stops 42d, and the lenses 42cl of the lens members 42c are respectively located on optical axes of light beams L.

Subsequently, as shown in FIG. 20, a bending optical element wafer 13' including a plurality of the bending optical elements 43 is bonded to a first surface 12f' forming an emission surface of the light beam L of the lens unit wafer 12', specifically, an outer surface of the lens wafer 12e' such that the bending optical elements 43 are respectively opposed to the lens units 42 and incident surfaces 43c of the bending optical elements 43 are set in contact with the lens units 42. An optical unit wafer 10' including a plurality of the optical units 41 is formed.

Subsequently, as shown in FIG. 21, when the optical unit wafer 10' is separated and individualized for each of the lens units 42 and the bending optical elements 43, i.e., for each of the optical units 41, a plurality of the optical units 41 shown in FIGS. 15 and 16 are manufactured.

Finally, when the image pickup unit 45 is manufactured, as shown in FIG. 18, the solid-state image pickup devices 44 are respectively aligned and adjusted and bonded to the emission surfaces 43a of the bending optical elements 43 of the individualized optical units 41.

Specifically, the solid-state image pickup devices 44 are respectively bonded to the emission surfaces 43a in positions where spaces are formed between the light receiving sections 44a and the optical surfaces 43dt and the light receiving sections 44a receive the light beams L emitted from the optical surfaces 43dt. As a result, a plurality of the image pickup units 45 shown in FIGS. 17 and 18 are manufactured.

With such a configuration, since the solid-state image pickup device 44 is individually bonded, work efficiency falls from that in the first embodiment. Otherwise, effects same as those in the first embodiment can be obtained. Besides, the solid-state image pickup device 44 is joined to the emission surface 43a of the bending optical element 43 with a space formed on the light receiving section 44a of the solid-state image pickup device 44. Therefore, the solid-state image pickup device 44 can be formed without spoiling an effect of a microlens used for improving the performance of the image pickup unit 45. Since the bending optical element 43 is arranged on the solid-state image pickup device 44, a degree of freedom in optical design is improved. Compared with the first embodiment, the image pickup unit 45 can be formed low in height.

The optical unit or the image pickup unit explained in the first and second embodiments is provided in, for example, an endoscope.

As shown in FIG. 22, an endoscope apparatus 101 includes an endoscope 102 and a peripheral apparatus 100. A main

section of the endoscope 102 includes an operation section 103, an insertion section 104, and a universal cord 105.

A main section of the peripheral apparatus 100 includes a light source device 121, a video processor 122, a connection cable 123, a keyboard 124, and a monitor 125 arranged on a rack 126. The endoscope 102 and the peripheral apparatus 100 having such configurations are connected to each other by a connector 119.

The insertion section 104 of the endoscope 102 includes a distal end portion 106, a bending portion 107, and a flexible tube portion 108. An object lens 111 is disposed on a side surface of the distal end portion 106. The image pickup unit 5 or the image pickup unit 45 is incorporated in the distal end portion 106.

The connector 119 is provided at the distal end of the universal cord 105 of the endoscope 102. The connector 119 is connected to the light source device 121 of the peripheral apparatus 100. A not-shown light guide cap forming an end of a not-shown light guide, an electric contact section to which an end of a not-shown image pickup cable is connected, and the like are disposed in the connector 119.

The image pickup cable is inserted from the solid-state image pickup device 4 or the solid-state image pickup device 44 in the distal end portion 106 to the electric contact section in the connector 119 through the insertion section 104, the operation section 103, and the universal cord 105. The image pickup cable transmits an electric signal of an image picked up by the solid-state image pickup device 4 or the solid-state image pickup device 44 to the video processor 122.

As explained above, if the optical unit or the image pickup unit explained in the first and second embodiments is provided in the distal end portion of the insertion section of the endoscope, the distal end portion can be further reduced in diameter.

The optical unit or the image pickup unit explained in the first and second embodiments may be applied not only to the endoscope but also to a cellular phone with camera and a digital camera.

As explained above, according to the present invention illustrated in the first and second embodiments, it is possible to reduce work for adjusting an angle of deviation and centering of an optical system in an optical unit. Further, it is possible to provide a manufacturing method for an optical unit and a manufacturing method for an image pickup unit that can reduce work for adjusting an angle of deviation and centering of an optical system in an optical unit and efficiently manufacture an optical unit or an image pickup unit and provide an optical unit and an image pickup unit manufactured by the manufacturing methods.

In other words, since an optical unit or an image pickup unit is formed at a wafer level, focus adjustment is made unnecessary by adjusting and managing the thickness of a wafer forming the optical unit or the image pickup unit. Further, accurate alignment can be easily performed by using a wafer process. Therefore, work for adjusting an angle of deviation, centering, and the like of an optical system in the optical unit is substantially reduced and a large number of optical units or image pickup units can be collectively formed. Therefore, it is possible to realize high yield and low cost.

The present invention illustrated in the first and second embodiments are as explained below.

(1) A manufacturing method for an optical unit including:

a step of bonding plural lens wafers, on which optical components are formed, and forming a lens unit wafer including plural lens units;

a step of bonding a bending optical element wafer including plural bending optical elements to a first surface of the

11

lens unit wafer such that the plural bending optical elements are respectively opposed to the plural lens units and forming an optical unit wafer; and

a step of separating and individualizing the optical unit wafer for each of the lens units and the bending optical elements and manufacturing plural optical units.

(2) A manufacturing method for an image pickup unit including:

a step of bonding plural lens wafers, on which optical components are formed, and forming a lens unit wafer including plural lens units;

a step of bonding a bending optical element wafer including plural bending optical elements to a first surface of the lens unit wafer such that the plural bending optical elements are respectively opposed to the plural lens units and forming an optical unit wafer;

a step of bonding a sensor wafer including plural solid-state image pickup devices to a second surface opposed to the first surface of the lens unit wafer in the optical unit wafer such that the plural solid-state image pickup devices are respectively opposed to the plural lens units and forming an image pickup unit wafer; and

a step of separating and individualizing the image pickup unit wafer for each of the lens units, the bending optical elements, and the solid-state image pickup devices and manufacturing plural image pickup units.

(3) The manufacturing method for an image pickup unit according to (2) above, wherein

the first surface of the lens unit wafer forms incident surfaces of light beams on the respective lens units, and

the step of forming an image pickup unit wafer is bonding the sensor wafer to the second surface, which forms emission surfaces of light beams from the respective lens units of the lens unit wafer, in positions where light receiving sections of the respective solid-stage image pickup devices receive light beams emitted from the respective lens units.

(4) A manufacturing method for an image pickup unit including:

a step of bonding plural lens wafers, on which optical components are formed, and forming a lens unit wafer including plural lens units;

a step of bonding a bending optical element wafer including plural bending optical elements to a first surface of the lens unit wafer such that the plural bending optical elements are respectively opposed to the plural lens units and forming an optical unit wafer;

a step of separating and individualizing the optical unit wafer for each of the lens units and the bending optical elements and manufacturing plural optical units; and

a step of respectively bonding solid-state image pickup devices to emission surfaces of light beams of the bending optical elements of the respective optical units.

(5) The manufacturing method for an image pickup unit according to (4) above, wherein

recesses are respectively formed in the emission surfaces of the respective bending optical elements and optical surfaces are respectively formed on bottom surfaces of the recesses, and

the step of bonding solid-stage image pickup devices is bonding the solid-state image pickup devices in positions where spaces are formed between the respective light receiving section of the solid-state image pickup devices and the optical surfaces of the bending optical elements and the light receiving sections receive light beams emitted from the respective optical surfaces.

12

(6) The manufacturing method for an image pickup unit according to (4) or (5) above, wherein

the first surface of the lens unit wafer forms emission surfaces of light beams from the respective lens units, and

the step of forming an optical unit wafer is bonding the bending optical element wafer to the emission surfaces of the lens unit wafer.

(7) An optical unit manufactured by the manufacturing method for an optical unit according to (1) above.

(8) An image pickup unit manufactured by the manufacturing method for an image pickup unit according to any one of (2) to (6) described above.

(9) An endoscope including the optical unit according to (7) above.

(10) An endoscope including the image pickup unit according to (8) above.

(Third Embodiment)

An optical unit and an image pickup unit according to a third embodiment of the present invention are explained below. As shown in FIGS. 23 and 24, a main section of an image pickup unit 201 according to the present embodiment includes an image pickup device 202 and an optical unit 203.

A main section of the optical unit 203 includes a flat plate 217 as an optical component, a spacer member 208 as an optical component bonded on the flat plate 217, a flat plate 218 as an optical component bonded on the spacer member 208, a stop 207 as an optical component bonded on the flat plate 218, and a flat plate 219 as an optical component bonded on the stop 207. In other words, the optical unit 203 is formed as a laminated body formed by bonding the plural optical components 217 to 219, 207, and 208.

The stop 207 may be provided between the flat plate 217 and the flat plate 218. The spacer member 208 may be provided between the flat plate 218 and the flat plate 219. Further, the spacer member 208 does not have to be provided.

The flat plate 217 has an image pickup lens 217a in a first area 261 in a state of plan view from above of the optical unit 203, for example, the center area. The flat plate 217 is formed of a transparent member, for example, glass.

The flat plate 218 has an image pickup lens 218a in the first area 261 and has, for example, four illumination lenses 218b in second areas 262 that avoid the first area 261 in the state of plan view from above of the optical unit 203, for example, a peripheral area of the first area 261. The flat plate 218 is formed of a transparent member, for example, glass. The second areas 262 are areas other than an area where a light beam from a subject passes in the optical unit 203. Specifically, the center area in the state of plan view from above of the optical unit 203 is the first area 261 having a substantially circular shape. Areas other than the first area 261 are the second areas 262. When the state of plan view from above of the optical unit 203 is a rectangular shape, it is desirable that the illumination lenses 218b are respectively arranged, in particular, at four corners in the second areas 262. It goes without saying that only one illumination lens 218b may be provided.

The flat plate 219 has an image pickup lens 219a in the first area 261 and has, for example, four illumination lenses 219b in the second areas 262. The flat plate 219 is made of a transparent member, for example, glass. The image pickup lenses 217a to 219a are provided to be opposed to one another in a laminating direction S of the optical components 217 to 219, 207, and 208 in the first area 261. The illumination lenses 218b and 219b are provided to be opposed to one another in the laminating direction S in the second areas 262.

Specifically, in the optical unit 203, an image pickup optical section A having the image pickup lenses 217a, 218a, and

219a is formed along the laminating direction S in the first area **261**. Illumination optical sections B having the illumination lenses **218b** and **219b** are formed along the laminating direction S in the second areas **262**.

The flat plates **217** to **219** may be formed of transparent resin or a composite member of the transparent resin and the glass without being limited to be formed of glass.

The spacer member **208** sets a space in the laminating direction S between the flat plate **217** and the flat plate **218** to an arbitrary dimension. The spacer member **208** is formed of a glass plate or a resin sheet. The stop **207** decides the brightness (F number) of light made incident on the image pickup lenses **217a** to **219a** and blocks an unnecessary ray made incident on the image pickup optical section A. The stop **207** is formed of a black resin sheet or metal plate.

As shown in FIG. **24**, in the second areas **262** of the optical unit **203**, first recesses **203h** are formed in the flat plate **217**, the spacer member **208**, and the flat plate **218** from a bottom surface **203t** of the optical unit **203** along the laminating direction S.

The image pickup device **202** including, for example, a CMOS semiconductor device is bonded to the bottom surface **203t** of the optical unit **203** to be integral with the optical unit **203**. Specifically, the image pickup device **202** has an image pickup section **204** and first peripheral circuit sections **205** amounted with light emitting elements **209** including, for example, white LEDs. The image pickup device **202** is bonded to the bottom surface **203t** of the optical unit **203** such that the image pickup section **204** is located in the first area **261**, the first peripheral circuit sections **205** and the light emitting elements **209** are located in the second areas **262**, and the light emitting elements **209** are located in the first recesses **203h**.

Light blocking members **210** that prevent illumination light beams irradiated from the light emitting elements **209** from being made incident on the image pickup optical section A is provided in the circumferential surface of the first recesses **203h**. Since the incidence of the illumination light beams on the image pickup optical section A is eliminated by the light blocking members **210**, the image pickup section **204** can acquire a high-definition image.

The illumination light beams irradiated from the light emitting elements **209** are evenly expanded and irradiated to a subject in the illumination lenses **218b** and **219b** in the illumination optical sections B. Light emitting operation of the light emitting elements **209** is controlled by a not-shown control section outside the image pickup unit **201** in synchronization with image pickup operation of the image pickup section **204**.

As shown in FIG. **23**, in the present embodiment, an external shape of the image pickup device **202** and an external shape of the optical unit **203** are the same. This is because, when the image pickup unit **201** is manufactured, plural lens wafers, i.e., a lens wafer including the flat plate **217**, a lens wafer including the spacer member **208**, a lens wafer including the flat plate **218**, a lens wafer including the stop **207**, and a lens wafer including the flat plate **219** are bonded and laminated to form an optical unit wafer, a sensor wafer including the image pickup device **202** is bonded to the optical unit wafer to form an image pickup unit wafer, and then the image pickup unit wafer is sliced and divided by, for example, dicing to manufacture the image pickup unit **201**.

In FIG. **23**, an external shape of the image pickup unit **201** is shown as a square shape. However, the external shape of the image pickup unit **201** may be a polygonal shape such as a hexagonal shape.

After the optical unit **203** is separated from the optical unit wafer, the image pickup unit **201** may be formed by bonding the image pickup device **202** separated from the sensor wafer to the optical unit **203**. Further, after the image pickup device **202** is bonded to the optical unit wafer, the image pickup unit **201** may be formed by separating the image pickup device **202** or, after the optical unit **203** is bonded to the sensor wafer, the image pickup unit **201** may be formed by separating the optical unit **203**.

The external shapes of the optical unit **203** and the image pickup device **202** do not need to be the same. The optical unit **203** and the image pickup device **202** may be formed in different shapes.

As explained above, in the present embodiment, in the image pickup unit **201**, the image pickup optical section A is formed in the first area **261** of the optical unit **203** and the illumination optical sections B are formed in the second areas **262**. The image pickup section **204** is located in the first area **261**. The first peripheral circuit sections **205** and the light emitting elements **209** are located in the second areas **262**.

Consequently, since the areas other than the image pickup optical section A can be used as the illumination optical sections B, it is possible to combine illumination functions to improve the functions without increasing an image pickup unit in size. When the image pickup unit is provided at, for example, an insertion section distal end of an endoscope, an insertion section distal end portion can be reduced in size. When the image pickup unit is provided in a capsule endoscope, the capsule endoscope itself can be reduced in size. Since the image pickup optical section A and the illumination optical sections B can be integrally manufactured in the optical unit **203**, assembly and machining cost for the image pickup unit **201** is reduced compared with the conventional ones.

Therefore, it is possible to provide an optical unit and an image pickup unit that can effectively utilize an area other than an area where a light beam from a subject passes and realize a reduction in size.

(Fourth Embodiment)

An optical unit and an image pickup unit according to a fourth embodiment of the present invention are explained below. Configurations of the optical unit and the image pickup unit according to the present embodiment are different from those of the optical unit and the image pickup unit according to the third embodiment in that a lens having a rectangular shape in plan view from above is provided on the image pickup lens **217a** of the flat plate **217** and that a part of the second areas **262** of the optical unit is set as a third area **263** and a radio transmitting and receiving section is provided in the third area **263**. Therefore, only these differences are explained. Components same as those in the third embodiment are denoted by the same reference numerals and signs and explanation of the components is omitted.

As shown in FIG. **25**, a resin lens **206** having a curved surface on the surface of a glass plane is complexly formed on the image pickup lens **217a** of the flat plate **217**. As shown in FIG. **26**, the resin lens **206** is formed in a shape projecting in a convex shape upward from a top surface formed in a plane of the image pickup lens **217a**. A shape in plan view from above of the resin lens **206** is a rectangular shape obtained by linearly cutting off four directions of a circular shape to match a shape of the image pickup section **204** of the image pickup device **202**.

This is because, since an external shape of the image pickup section **204** of the image pickup device **202** is generally a square shape, it is desirable to form an effective external shape of the resin lens **206** in a substantial square shape

15

according to a shape of a passing area of a light beam that reaches the image pickup section **204**.

The resin lens **206** may be formed on the image pickup lens **218a** or on the image pickup lens **219a** without being limited to be formed on the image pickup lens **217a**. Further, the resin lens **206** may be formed on the illumination lenses **218b** or on the illumination lenses **219b**.

As shown in FIGS. **25** and **26**, a radio transmitting and receiving section **G** is provided in the third area **263**, which is a part of the second areas **262** of the optical unit **203**. Because the third area **263** is a part of the second areas **262**, the third area **263** is an area other than an area where a light beam from a subject passes. An area where the illumination lenses **218b** are not formed in the second areas **262** is set as the third area **263**. The radio transmitting and receiving section **G** is disposed in the third area **263**.

In the third area **263** of the optical unit **203**, a second recess **203g** is formed in the flat plate **217**, the spacer member **208**, and the flat plate **218** from the bottom surface **203t** of the optical unit **203** along the laminating direction **S**.

In the present embodiment, the image pickup device **202** includes the image pickup section **204**, the first peripheral circuit sections **205** mounted with the light emitting elements **209**, a radio transmitting and receiving element **211** including a transmitting and receiving antenna and a transmitting and receiving circuit formed as patterns, and a second peripheral circuit section **255** mounted with the radio transmitting and receiving element **211**. The image pickup device **202** is bonded to the bottom surface **203t** of the optical unit **203** such that the image pickup section **204** is located in the first area **261**, the first peripheral circuit sections **205** and the light emitting elements **209** are located in the second areas **262**, the light emitting elements **209** are located in the first recesses **203h**, the second peripheral circuit section **255** and the radio transmitting and receiving element **211** are located in the third area **263**, and the radio transmitting and receiving element **211** is located in the second recess **203g**.

The radio transmitting and receiving element **211** can transmit an output signal of the image pickup device **202** to the outside by radio and control the operation of the image pickup device **202** from the outside. The radio transmitting and receiving element **211** can also transmit an identification signal peculiar to the image pickup unit **201**.

Since the image pickup unit **201** according to the present embodiment includes the radio transmitting and receiving element **211**, the image pickup unit **201** can be applied to, for example, a capsule endoscope for medial use.

In the present embodiment, the light emitting elements **209** located in the second areas **262** is an organic EL including a thin-film luminous element and is directly formed in the first peripheral circuit sections **205** of the image pickup device **202**. Light emitting operation of the light emitting elements **209** is controlled by the first peripheral circuit sections **205** of the image pickup device **202** in synchronization with image pickup operation of the image pickup device **202**.

As explained above, in the present embodiment, a part of the second areas **262** of the optical unit **203** is set as the third area **263** and the radio transmitting and receiving element **211** is provided in the third area **263**.

Therefore, since areas other than the image pickup optical section **A** of the optical unit **203** can be used not only as the illumination optical sections **B** but also as the radio transmitting and receiving sections **G**, it is possible to realize a high-function small image pickup unit having not only an illumination function but also a radio function.

In the present embodiment, the resin lens **206** having a rectangular shape in plan view from above is formed on the

16

image pickup lens **217a** integrally with the image pickup lenses **217a**. Therefore, it is possible to combine the illumination function, the radio function, and the like to improve the functions without increasing an image pickup unit in size. For example, when the image pickup unit is provided at, for example, an insertion section distal end of an endoscope, an insertion section distal end section can be reduced in size and diameter. Further, when the image pickup unit is provided in a capsule endoscope, the capsule endoscope itself can be reduced in size. Other effects of the present embodiment are the same as those in the third embodiment.

(Fifth Embodiment)

An optical unit and an image pickup unit according to a fifth embodiment of the present invention are explained below. Configurations of the optical unit and the image pickup unit according to the present embodiment are different from those of the optical unit and the image pickup unit according to the fourth embodiment in that the image pickup lens **218a** of the flat plate **218** includes a Fresnel lens and that the image pickup lens **217a** of the flat plate **217** includes an aspherical lens. Therefore, only the differences are explained. Components same as those in the fourth embodiment are denoted by the same reference numerals and signs and explanation of the components is omitted.

As shown in FIG. **27**, in the present embodiment, the image pickup lens **218a** includes a Fresnel lens **259**. The Fresnel lens **259** is formed by molding transparent resin and is thin compared with a normal convex lens. The image pickup lens **218a** may include a diffractive lens without being limited to the Fresnel lens.

The image pickup lens **217a** includes an aspherical lens **256**. Since the aspherical lens **256** is formed by molding glass at high temperature, a complicated lens shape is obtained compared with the normal convex lens. The illumination lenses **218b** and **219b** may include the Fresnel lens **259**, the diffractive lens, or the aspherical lens **256**.

The radio transmitting and receiving section **G** is provided in the third area **263** of the optical unit **203**. In the third area **263** of the optical unit **203**, a second recess **203m** is formed in the flat plate **217**, the spacer member **208**, and the flat plate **218** from the bottom surface **203t** of the optical unit **203** along the laminating direction **S**.

In the present embodiment, the image pickup device **202** includes the image pickup section **204**, the first peripheral circuit sections **205** mounted with the light emitting elements **209** including, for example, white LEDs, a radio transmitting and receiving element **251** including a coil-like transmitting and receiving antenna and a transmitting and receiving circuit, and the second peripheral circuit section **255** mounted with the radio transmitting and receiving element **251**. The image pickup device **202** is bonded to the bottom surface **203t** of the optical unit **203** such that the image pickup section **204** is located in the first area **261**, the first peripheral circuit sections **205** and the light emitting elements **209** are located in the second areas **262**, the light emitting elements **209** are located in the first recesses **203h**, the second peripheral circuit section **255** and the radio transmitting and receiving element **251** are located in the third area **263**, and the radio transmitting and receiving element **251** is located in the second recess **203m**.

The radio transmitting and receiving element **251** can transmit an output signal of the image pickup device **202** to the outside by radio and control the operation of the image pickup device **202** from the outside. The radio transmitting and receiving element **251** can also transmit an identification signal peculiar to the image pickup unit **201**.

In the present embodiment, as in the second embodiment, the radio transmitting and receiving element **251** transmits a signal outputted from the second peripheral circuit section **255** of the image pickup device **202** to the outside and receives a signal from the outside and transmits the signal to the second peripheral circuit section **255**.

Since the image pickup unit **201** having the configuration explained above includes the radio transmitting and receiving element **251**, the image pickup unit **201** can be applied to, for example, a capsule endoscope for medical use.

In the present embodiment, the image pickup lens **218a** includes the Fresnel lens **259** and the image pickup lens **217a** includes the aspherical lens **256**. Consequently, optical path length in the image pickup optical section A can be set shorter than that in the fourth embodiment. Therefore, the image pickup unit **201** can be further reduced in size and the performance of the image pickup optical section A can be further improved. Other effects are the same as those in the fourth embodiment.

A modification of the present embodiment is explained with reference to FIG. **28**. In the present embodiment explained above, the light emitting elements **209** are located in the second recesses **203h** in the illumination optical sections B. However, the present invention is not limited to this. As shown in FIG. **28**, light guides **212** may be arranged instead of the light emitting elements **209** in the illumination optical sections B. Not-shown lamps are arranged on proximal end sides of the light guides **212**. The light guides **212** transmit light beams emitted according to light emission of the lamps to the image pickup unit **201** as illumination light beams. The transmitted illumination light beams are expanded and irradiated to a subject in the illumination optical sections B.

In the present configuration, as shown in FIG. **28**, an external shape of the image pickup device **202** is set smaller than that of the optical unit **203** to avoid the light guides **212**. However, not-shown through holes for insertion are formed in the image pickup device **202** or four corners of the image pickup device **202** are chamfered, whereby distal ends of the light guides **212** are arranged in positions facing the illumination optical sections B.

In the present embodiment, the radio transmitting and receiving element **251** is provided in the third area **263**. However, the present invention is not limited to this. A sensor such as an acceleration sensor, a magnetic sensor, or a GPS, a motor, or an actuator such as a piezoelectric element may be arranged in the third area **263**. The same holds true in the fourth embodiment.

The optical unit or the image pickup unit explained in the third to fifth embodiments is able to be provided in, for example, the endoscope shown in FIG. **22**. An endoscope, for example, an endoscope for oblique view including the optical unit or the image pickup unit explained in the third to fifth embodiments at a distal end portion of an insertion section has a small diameter at the distal end portion.

The optical unit or the image pickup unit explained in the third to fifth embodiments may be provided in a capsule endoscope for medical use or may be applied not only to the endoscope but also to a cellular phone with camera and a digital camera.

As explained above, according to the present invention illustrated by the third to fifth embodiments, it is possible to provide an optical unit, an image pickup unit, a manufacturing method for an optical unit, and a manufacturing method for an image pickup unit that can effectively utilize an area other than an area where a light beam from a subject passes and realize a reduction in size.

Specifically, the present invention illustrated in the third to fifth embodiments is as explained below.

(1) An optical unit including a laminated body including:

an image pickup optical section formed to have, in a state of plan view from above of the laminated body formed by bonding plural optical components, an image pickup lens along a laminating direction of the optical components in a first area of the laminated body; and

an illumination optical section formed to have, in the state of plan view from above of the laminated body, an illumination lens along the laminating direction in a second area set to avoid the image pickup optical section.

(2) The optical unit according to (1) above, wherein

the image pickup lens and the illumination lens include plural lenses, and

a Fresnel lens or a diffractive lens is provided in at least one of at least a part of the image pickup lens and at least a part of the illumination lens.

(3) The optical unit according to (1) above, wherein at least a part of the image pickup lens has a rectangular external shape in plan view from above.

(4) The optical unit according to any one of (1) to (3) above further including a radio transmitting and receiving section in a third area that forms a part of the second area in the state of plan view from above of the laminated body.

(5) An image pickup unit including an optical unit and an image pickup device mounted with the optical unit including:

an image pickup optical section formed to have, in a state of plan view from above of the optical unit including a laminated body formed by bonding plural optical components, an image pickup lens along a laminating direction of the optical components in a first area of the optical unit;

an illumination optical section formed to have, in the state of plan view from above of the optical unit, an illumination lens along the laminating direction in a second area set to avoid the image pickup optical section;

a first recess drilled along the laminating direction from a bottom surface of the optical unit in the second area of the optical unit; and

the image pickup device having an image pickup section and a first peripheral circuit section, in which a light emitting element is provided, and bonded to the bottom surface of the optical unit such that the image pickup section is located in the first area, the first peripheral circuit section and the light emitting element are located in the second area, and the light emitting element is located in the first recess.

(6) The image pickup unit according to (5) above, wherein a light blocking member is provided on a circumferential surface of the first recess.

(7) The image pickup unit according to (5) or (6) above further including a radio transmitting and receiving section in a third area that forms a part of the second area in the state of plan view from above of the optical unit.

(8) The image pickup unit according to (7) above further including:

a second recess drilled along the laminating direction from the bottom surface of the optical unit in the third area of the optical unit;

the image pickup device including the image pickup section, the first peripheral circuit section, in which the light emitting element is provided, and a second peripheral circuit section, in which a radio transmitting and receiving element is provided, and bonded to the bottom surface of the optical unit such that the image pickup section is located in the first area, the first peripheral circuit section and the light emitting element are located in the second area and the light emitting

19

element is located in the first recess, and the second peripheral circuit section and the radio transmitting and receiving element are located in the third area and the radio transmitting and receiving element is located in the second recess.

(9) The image pickup unit according to any one of (5) to (8) above, wherein

the image pickup lens and the illumination lens include plural lenses; and

a Fresnel lens or a diffractive lens is used in at least one of at least a part of the image pickup lens and at least a part of the illumination lens.

(10) The image pickup unit according to any one of (5) to (9) above, wherein

the image pickup lens and the illumination lens include plural lenses; and

at least one of at least a part of the image pickup lens and at least a part of the illumination lens has a rectangular external shape in plan view from above.

(11) An endoscope including the optical unit according to any one of (1) to (4) above.

(12) An endoscope including the image pickup unit according to any one of (5) to (10) above.

Having described the preferred embodiments of the invention referring to the accompanying drawings, it should be understood that the present invention is not limited to those precise embodiments and various changes and modifications thereof could be made by one skilled in the art without departing from the spirit or scope of the invention as defined in the appended claims.

What is claimed is:

1. An optical unit including a laminated body, the optical unit comprising:

an image pickup optical section formed to have, in plan view when viewed from above the laminated body formed by bonding plural optical components, an image pickup objective lens along a laminating direction of the optical components, wherein the laminated body has a polygon shape in plan view when viewed from above, wherein the laminated body has a plurality of comers in plan view when viewed from above, wherein the laminated body has a center area in plan view when viewed from above, the center area excluding the plurality of comers, wherein the laminated body has a peripheral area in plan view when viewed from above, the peripheral area excluding the center area and including the plurality of comers, and wherein the image pickup objective lens is located only in the center area of the laminated body; and

an illumination optical section formed to have, in plan view when viewed from above the laminated body, a plurality of illumination lenses along the laminating direction, wherein the plurality of illumination lenses are located only at the plurality of comers of the laminated body in the peripheral area of the laminated body such that the plurality of illumination lenses are set to avoid the image pickup optical section;

wherein the laminated body has a plurality of recesses for housing a light emitting element and a radio transmitting and receiving section, the recesses being formed at the plurality of comers in plan view when viewed from above the laminated body.

2. The optical unit according to claim 1, wherein the image pickup lens and at least one illumination lens each includes plural lenses;

20

a lens group of the image pickup lens and a lens group of the at least one illumination lens are formed in the laminating direction with a common thickness and space; and

a Fresnel lens or a diffractive lens is provided in at least one of at least a part of the image pickup lens and at least a part of the at least one illumination lens.

3. The optical unit according to claim 1, wherein at least a part of the image pickup lens has a rectangular external shape in plan view from above.

4. The optical unit according to claim 1, wherein the polygon shape is a rectangle.

5. An image pickup unit, comprising:

an optical unit mounted with an image pickup device;

an image pickup optical section formed to have, in plan view when viewed from above the laminated body formed by bonding plural optical components, an image pickup objective lens along a laminating direction of the optical components, wherein the laminated body has a polygon shape in plan view when viewed from above, wherein the laminated body has a plurality of comers in plan view when viewed from above, wherein the laminated body has a center area in plan view when viewed from above, the center area excluding the plurality of comers, wherein the laminated body has a peripheral area in plan view when viewed from above, the peripheral area excluding the center area and including the plurality of comers, and wherein the image pickup objective lens is located only in the center area of the laminated body; and

an illumination optical section formed to have, in plan view when viewed from above the laminated body, a plurality of illumination lenses along the laminating direction, wherein the plurality of illumination lenses are located only at the plurality of comers of the laminated body in the peripheral area of the laminated body such that the plurality of illumination lenses are set to avoid the image pickup optical section;

wherein the image pickup unit further comprises:

at least one recess drilled along the laminating direction from a bottom surface of the optical unit in the peripheral area of the optical unit;

a light emitting element having an image pickup section and a first peripheral circuit section, in which a light emitting element is provided, and bonded to the bottom surface of the optical unit such that the image pickup section is located in the center area, the first peripheral circuit section and the light emitting element are located in the peripheral area, and the light emitting element is housed in the recess; and

a radio transmitting and receiving section located in the peripheral area in plan view when viewed from above the optical unit, and housed in the recess.

6. The image pickup unit according to claim 5, wherein a light blocking member is provided on a circumferential surface of the first recess.

7. The image pickup unit according to claim 5, further comprising:

an image pickup device including the first peripheral circuit section and the second peripheral circuit section, in which a radio transmitting and receiving element included in the radio transmitting and receiving section is provided, and bonded to the bottom surface of the optical unit such that the image pickup section is located in the center area, the first peripheral circuit section, the light emitting element, and the radio transmitting and receiving element are located in the peripheral area, the

light emitting element is located in a first recess of the at least one recess, and the radio transmitting and receiving element is located in a second recess of the at least one recess.

- 8.** The image pickup unit according to claim **7**, wherein: 5
the image pickup lens and at least one illumination lens include plural lenses; and
a Fresnel lens or a diffractive lens is used in at least one of at least a part of the image pickup lens and at least a part of the at least one illumination lens. 10
- 9.** The image pickup unit according to claim **8**, wherein: at least one of at least a part of the image pickup lens and at least a part of the at least one illumination lens has a rectangular external shape in plan view from above.
- 10.** The image pickup unit according to claim **5**, wherein 15
the polygon shape is a rectangle.

* * * * *