

US008816201B1

(12) **United States Patent**  
**Shotey et al.**

(10) **Patent No.:** **US 8,816,201 B1**  
(45) **Date of Patent:** **\*Aug. 26, 2014**

(54) **APPARATUS AND METHOD FOR COLLAPSIBLE AND EXPANDABLE ELECTRICAL DEVICE COVER**

(75) Inventors: **Marcus J. Shotey**, Scottsdale, AZ (US);  
**Jeffrey P. Baldwin**, Phoenix, AZ (US);  
**Iven Dieterle**, Tempe, AZ (US)

(73) Assignee: **Hubbell Incorporated**, Shelton, CT (US)

(\*) Notice: Subject to any disclaimer, the term of this patent is extended or adjusted under 35 U.S.C. 154(b) by 375 days.

This patent is subject to a terminal disclaimer.

(21) Appl. No.: **13/363,290**

(22) Filed: **Jan. 31, 2012**

**Related U.S. Application Data**

(63) Continuation of application No. 12/695,985, filed on Jan. 28, 2010, now Pat. No. 8,106,295.

(60) Provisional application No. 61/147,946, filed on Jan. 28, 2009.

(51) **Int. Cl.**  
**H02G 3/14** (2006.01)

(52) **U.S. Cl.**  
USPC ..... **174/66; 174/67; 439/135; 33/528**

(58) **Field of Classification Search**  
USPC ..... 174/66, 67; 220/241, 242; 439/135; 33/528

See application file for complete search history.

(56) **References Cited**

**U.S. PATENT DOCUMENTS**

6,825,413	B2 *	11/2004	Jeon et al.	174/50
6,848,916	B2 *	2/2005	Nakayama et al.	439/76.2
7,134,883	B2 *	11/2006	Werner et al.	439/76.1
7,388,758	B2 *	6/2008	Chen et al.	361/801
7,485,804	B2 *	2/2009	Dinh et al.	174/50
7,572,976	B1 *	8/2009	Merrill	174/50

\* cited by examiner

*Primary Examiner* — Dhirubhai R Patel

(74) *Attorney, Agent, or Firm* — Garrett V. Davis; Mark S. Bicks; Alfred N. Goodman

(57) **ABSTRACT**

An electrical device cover includes a base with a wall structure having at least two pairs of opposing walls located perpendicular to each other and an opening in a back side large enough to receive an electrical device. An exterior surface of at least a first wall has at least one rail running perpendicular to a plane in which the back side of the base resides and the base of a detachable hinge component is slidably coupled to the at least one rail. The detachable hinge component has at least one hinge member that is parallel to the base of the hinge component and a lid with at least one hinge tab in which the at least one hinge member seats such that the lid is pivotally coupled to the hinge component.

**20 Claims, 8 Drawing Sheets**

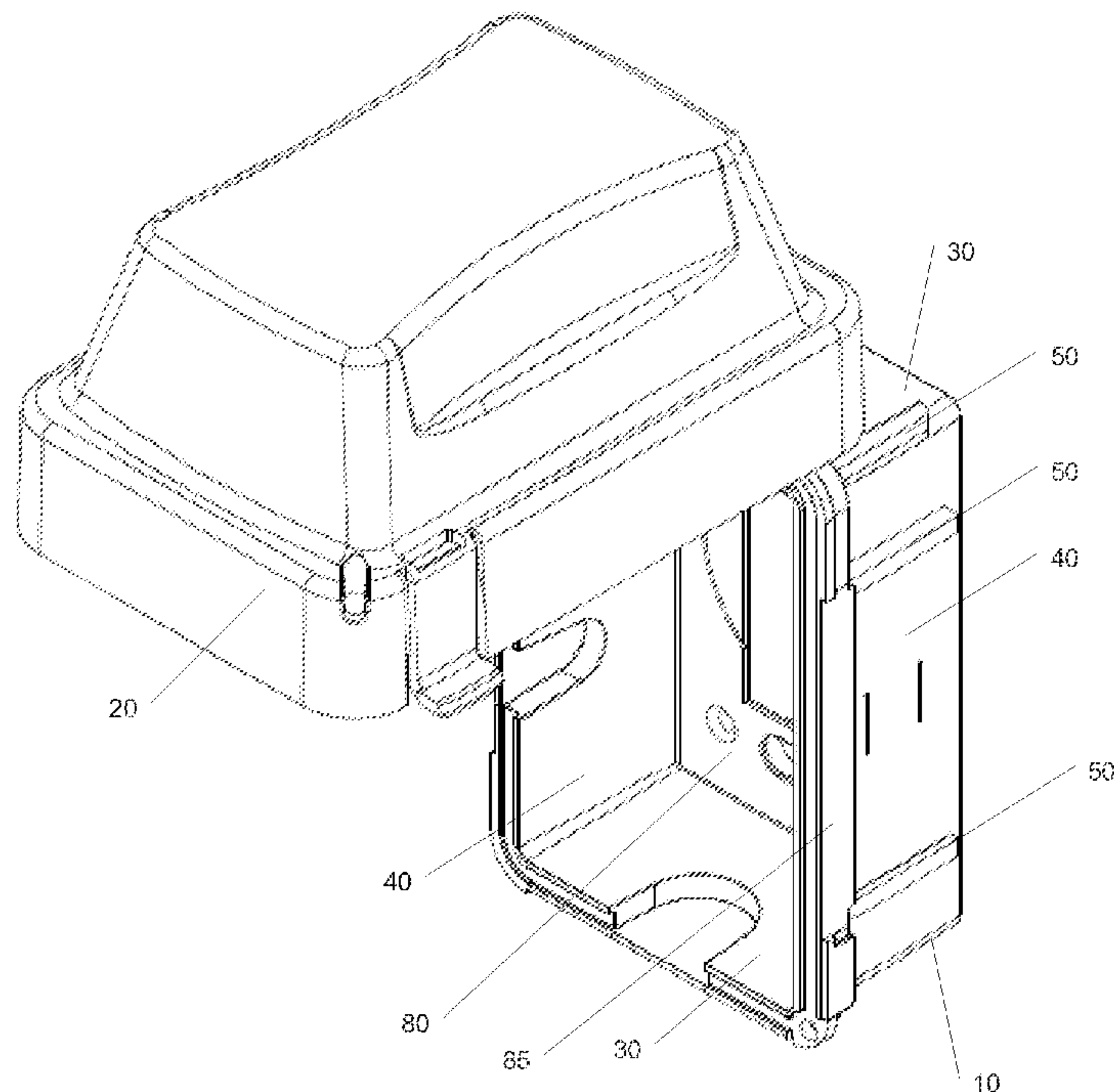

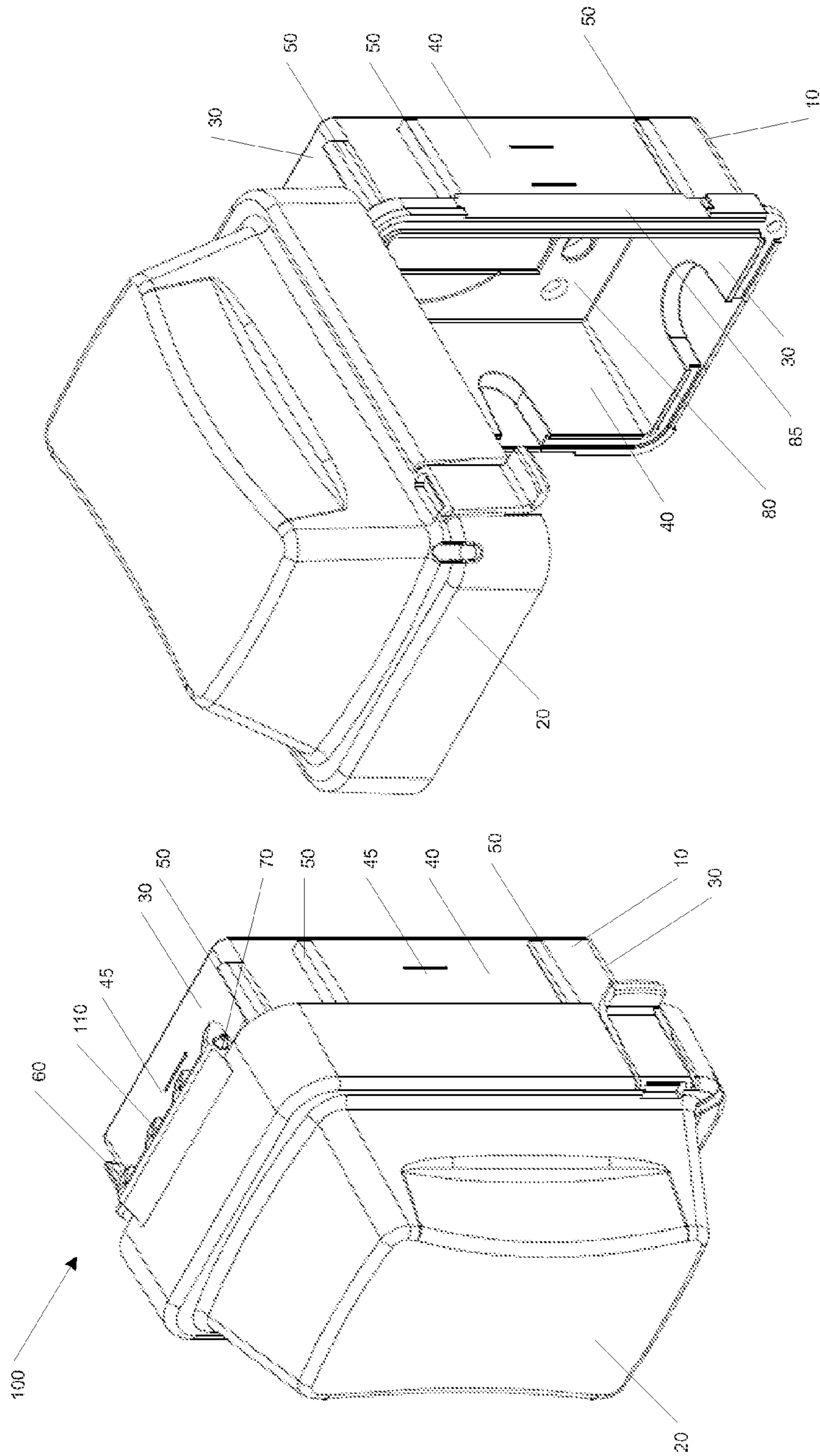

FIG. 1B

FIG. 1A

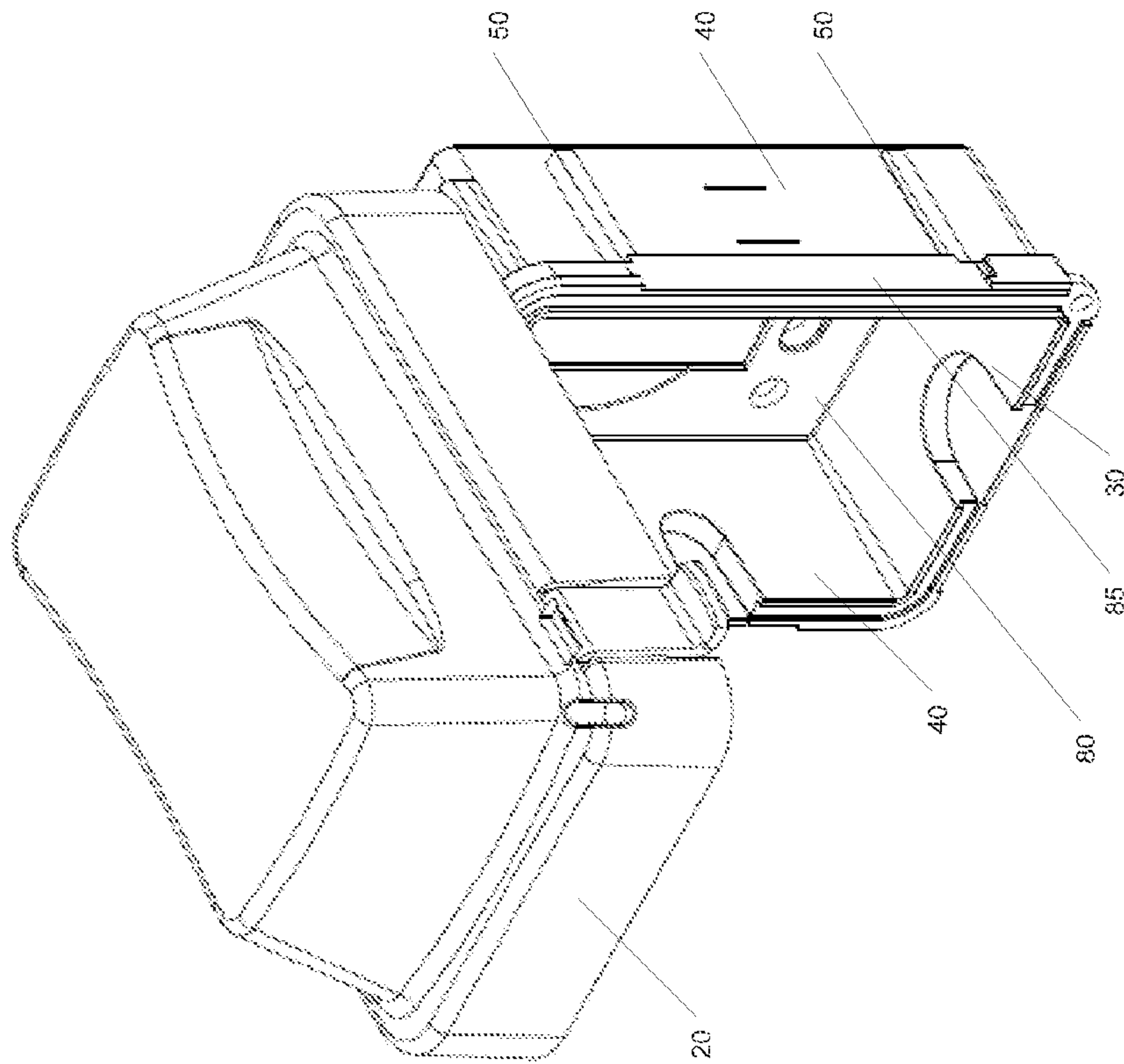

FIG. 2A

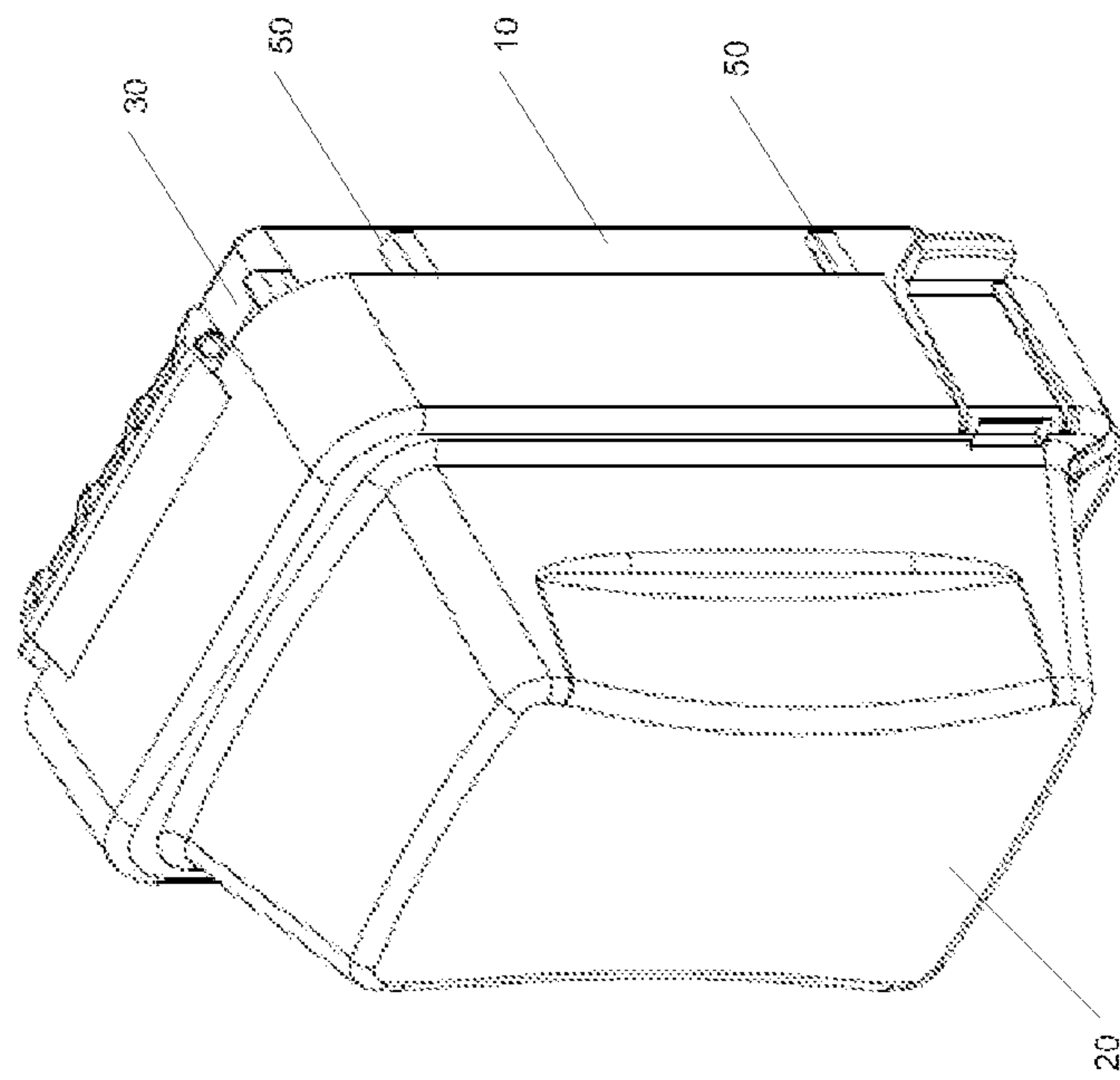

FIG. 2B



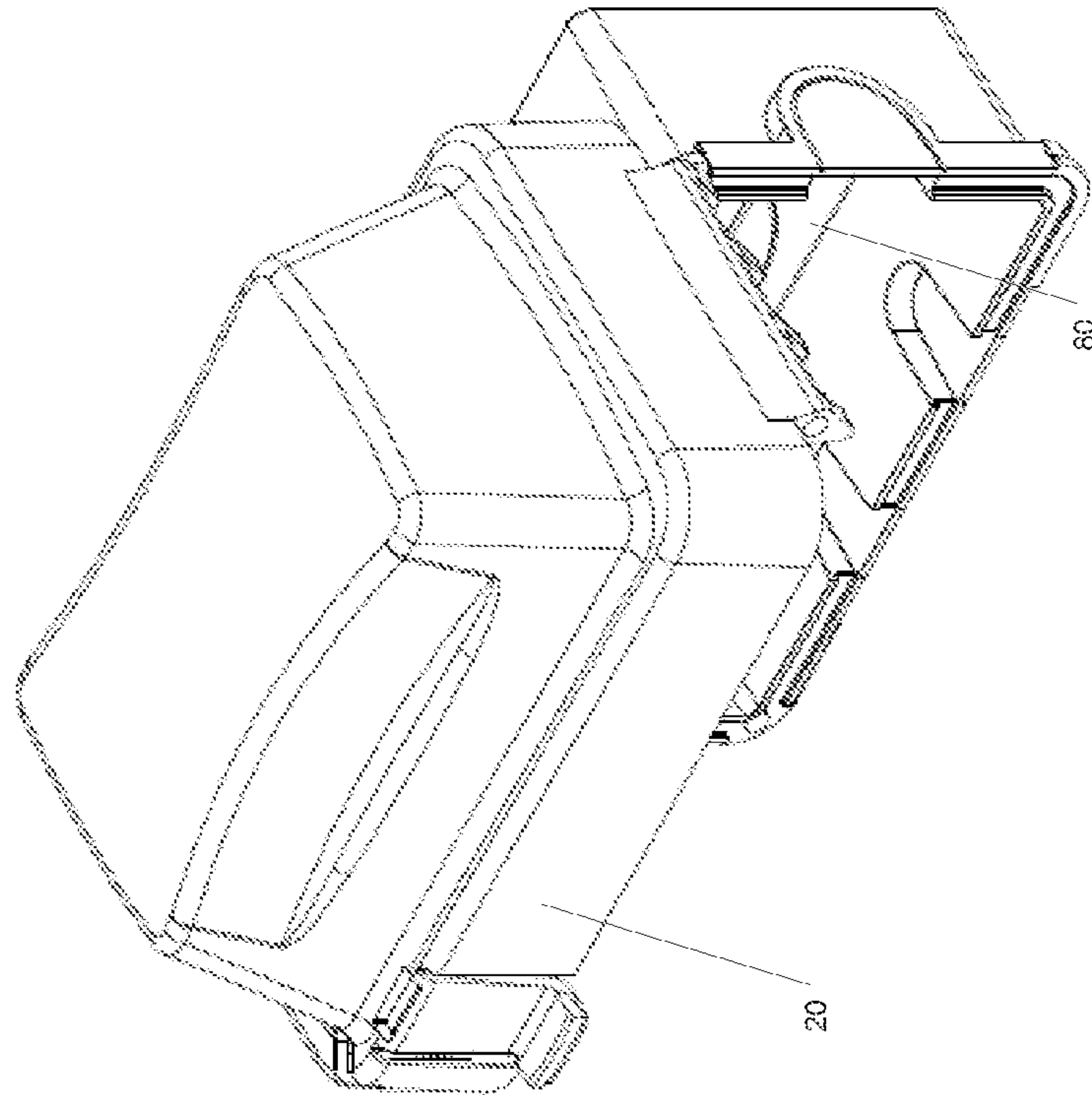

FIG. 3B

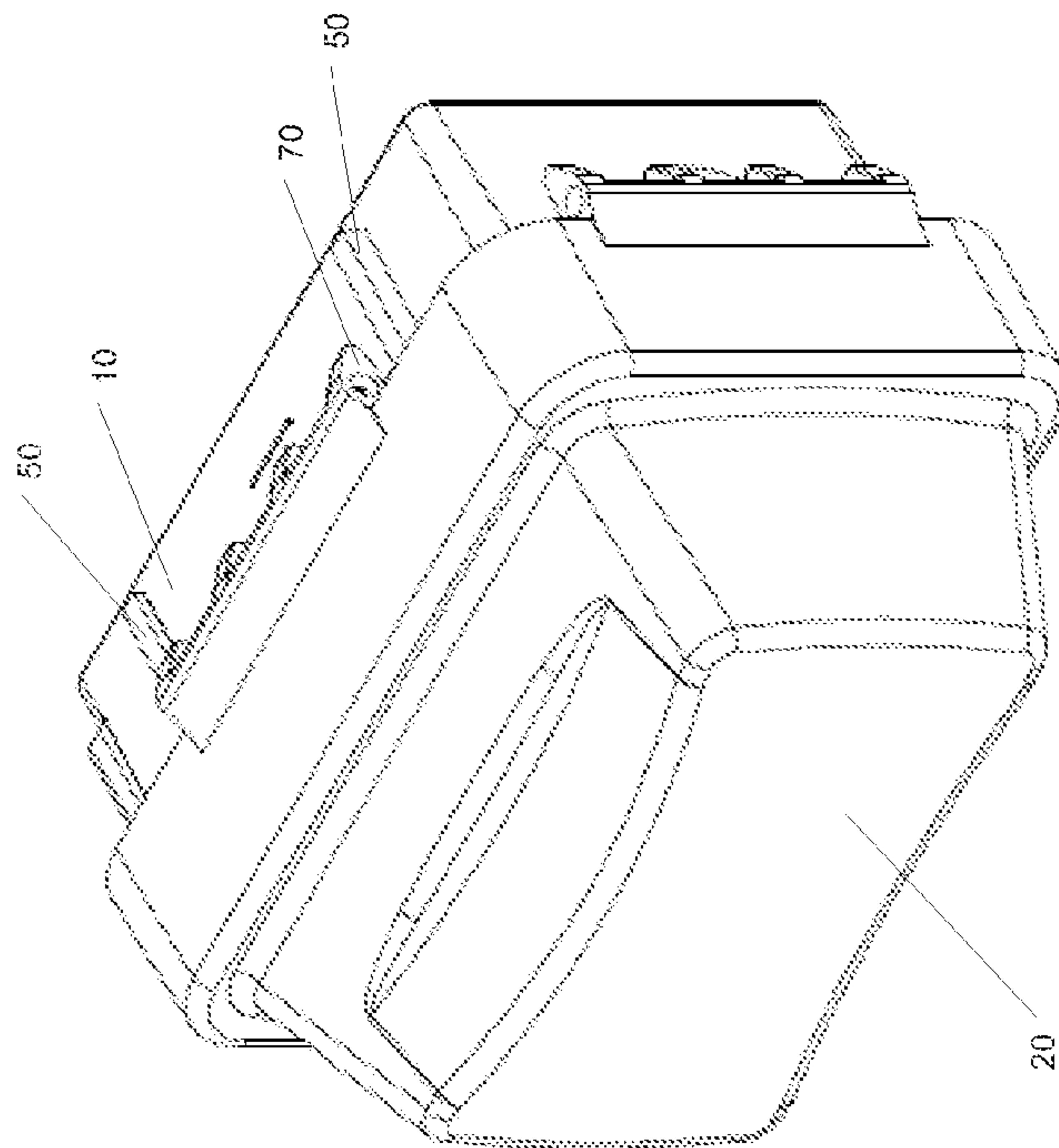

FIG. 3A

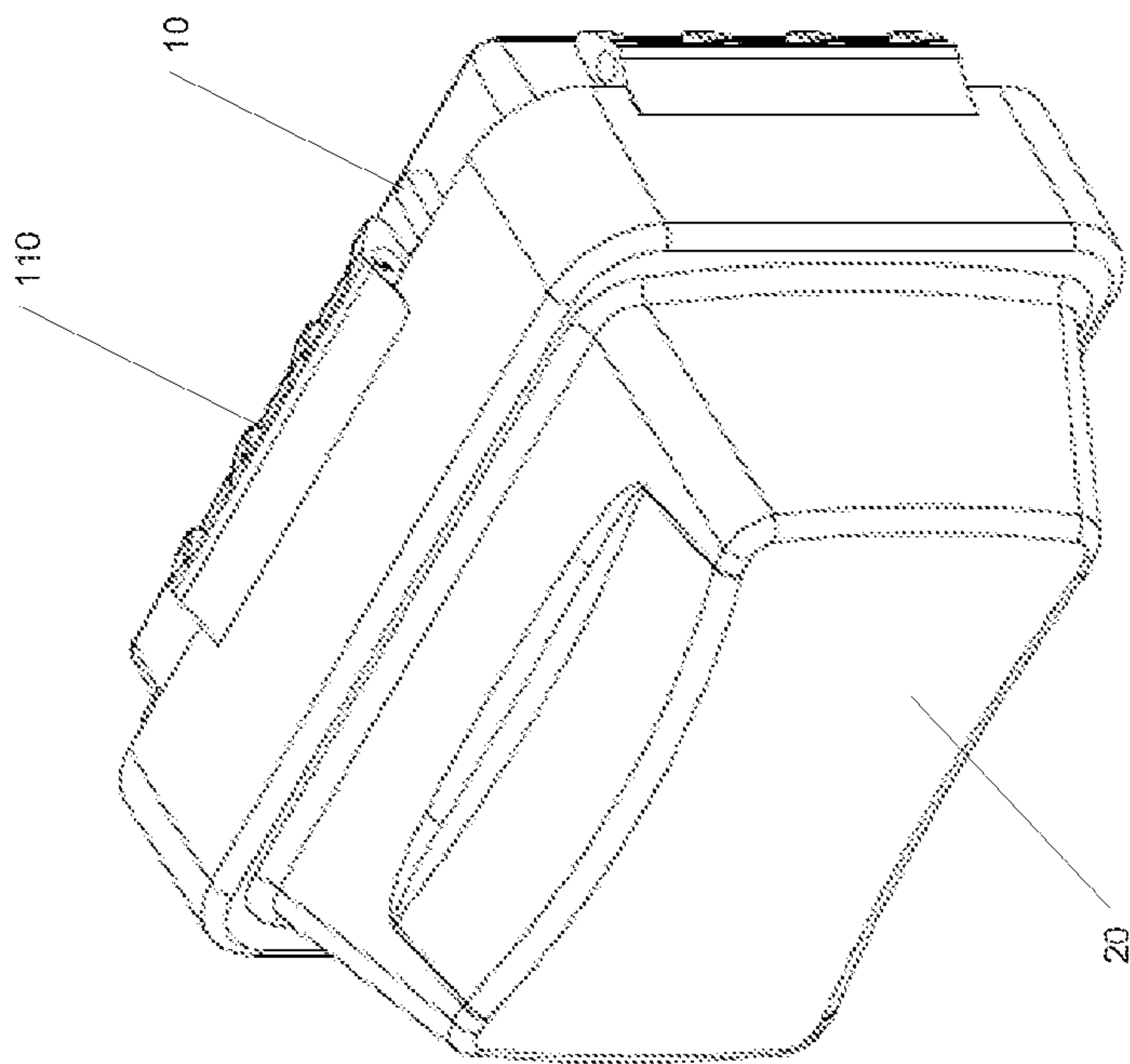

FIG. 4A

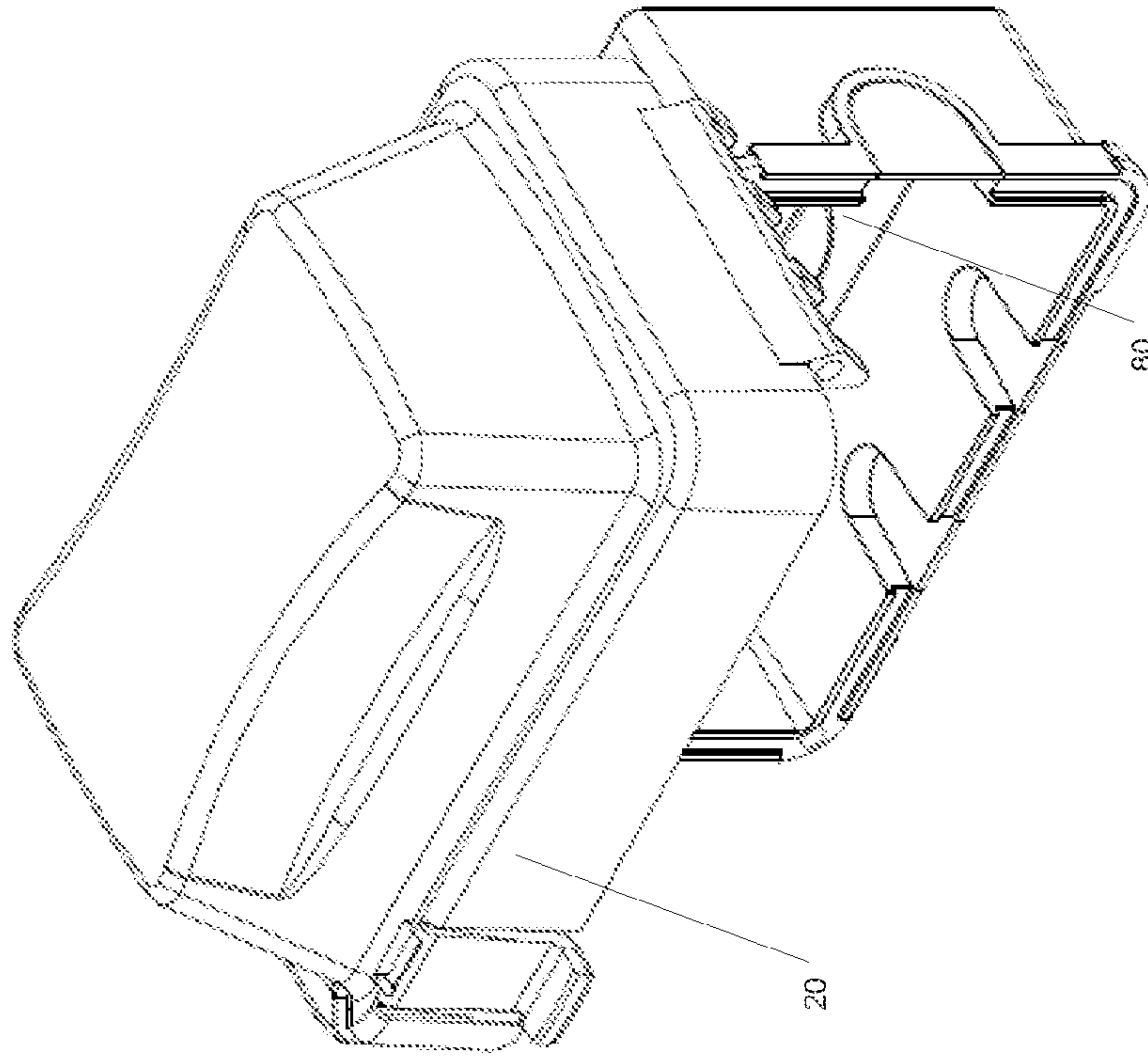

FIG. 4B

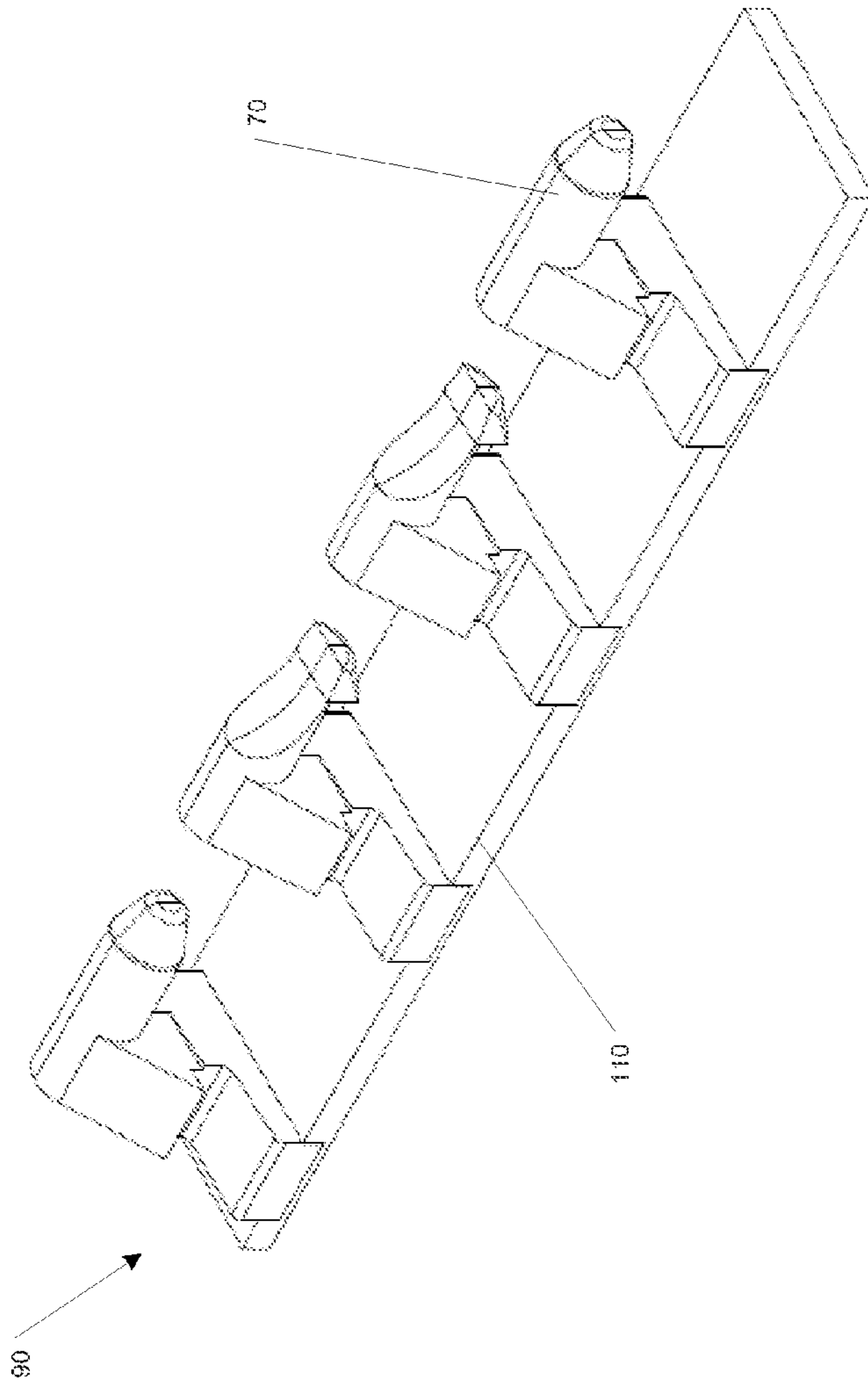

FIG. 5

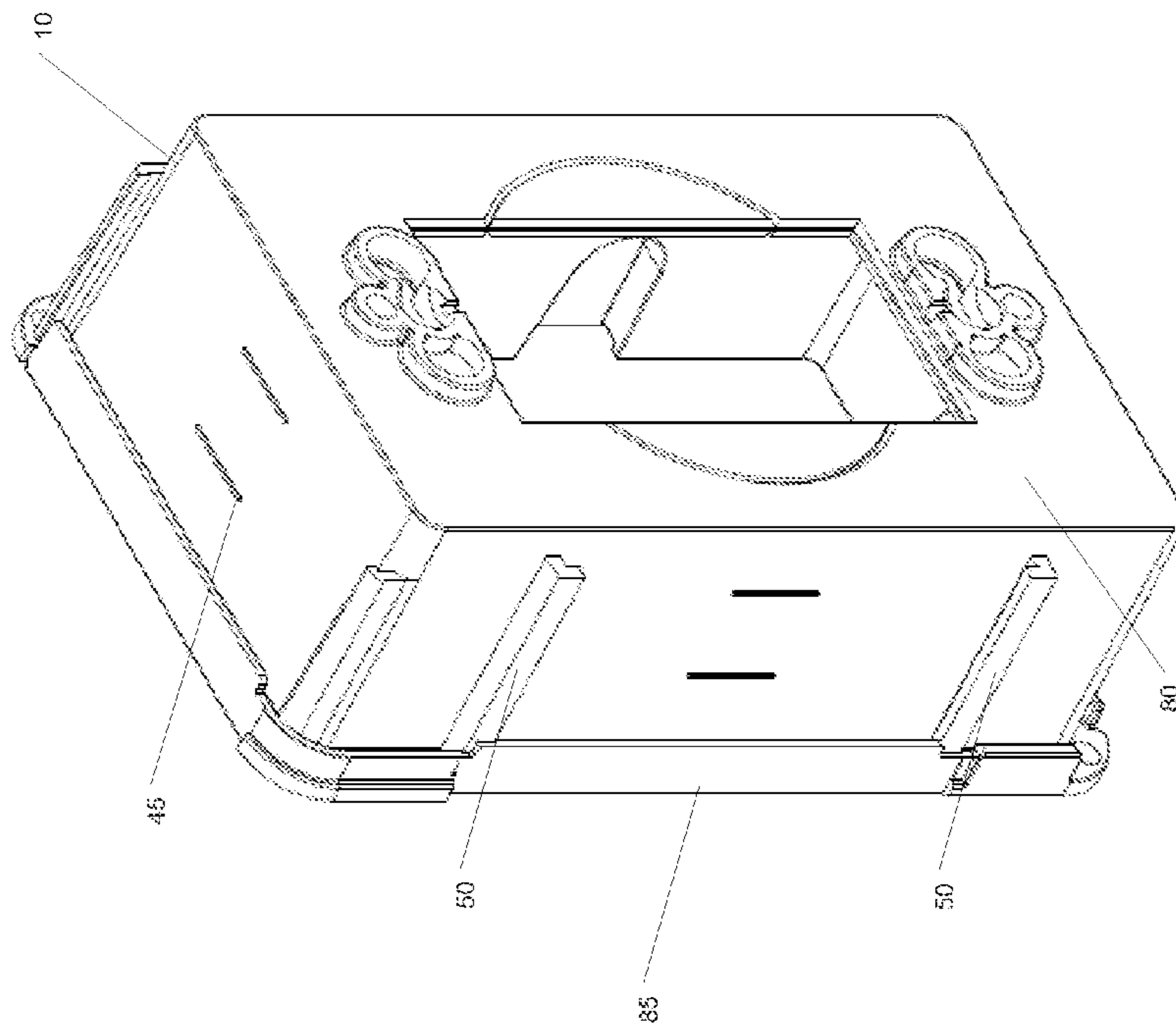

FIG. 6

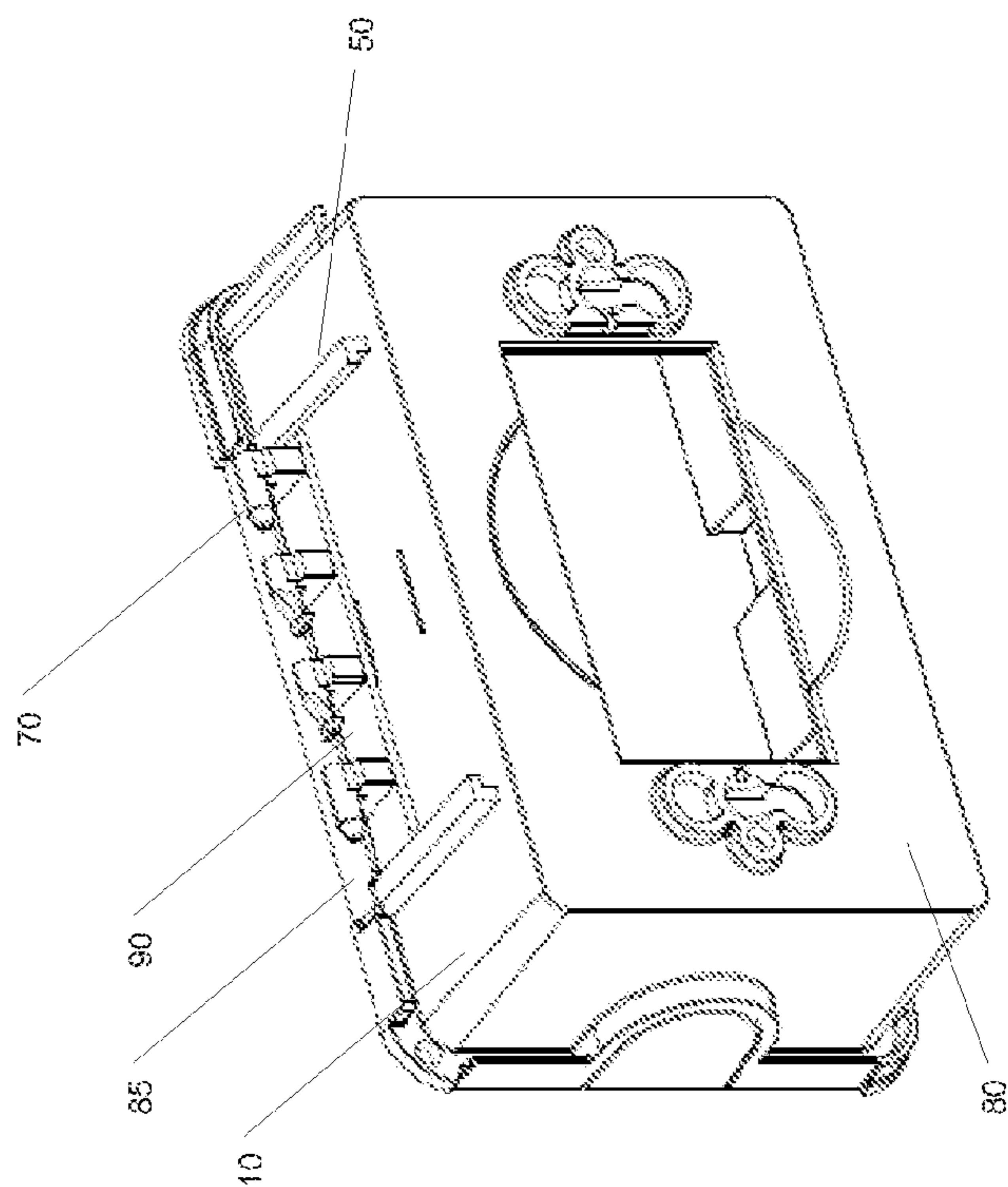

FIG. 7B

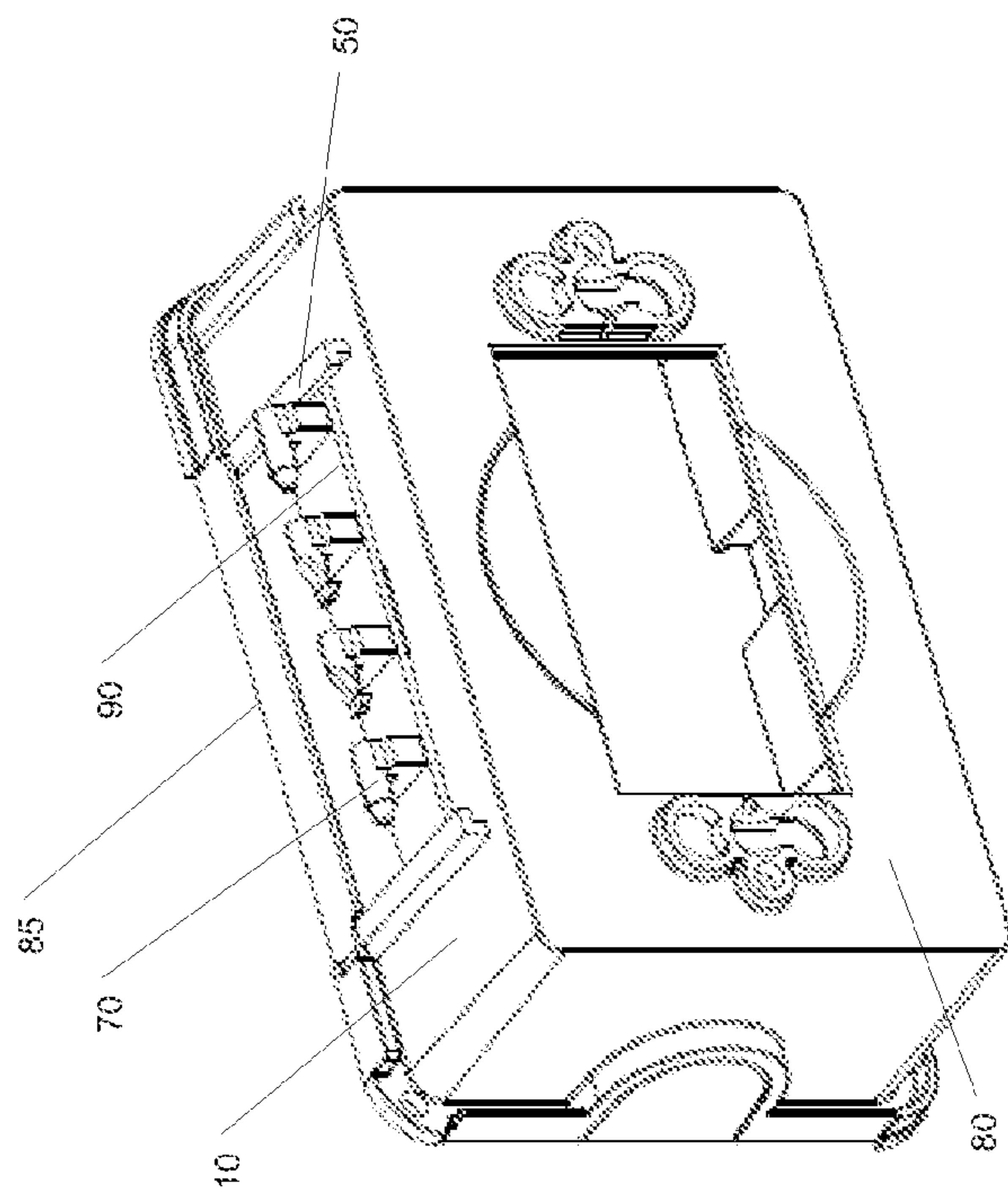

FIG. 7A



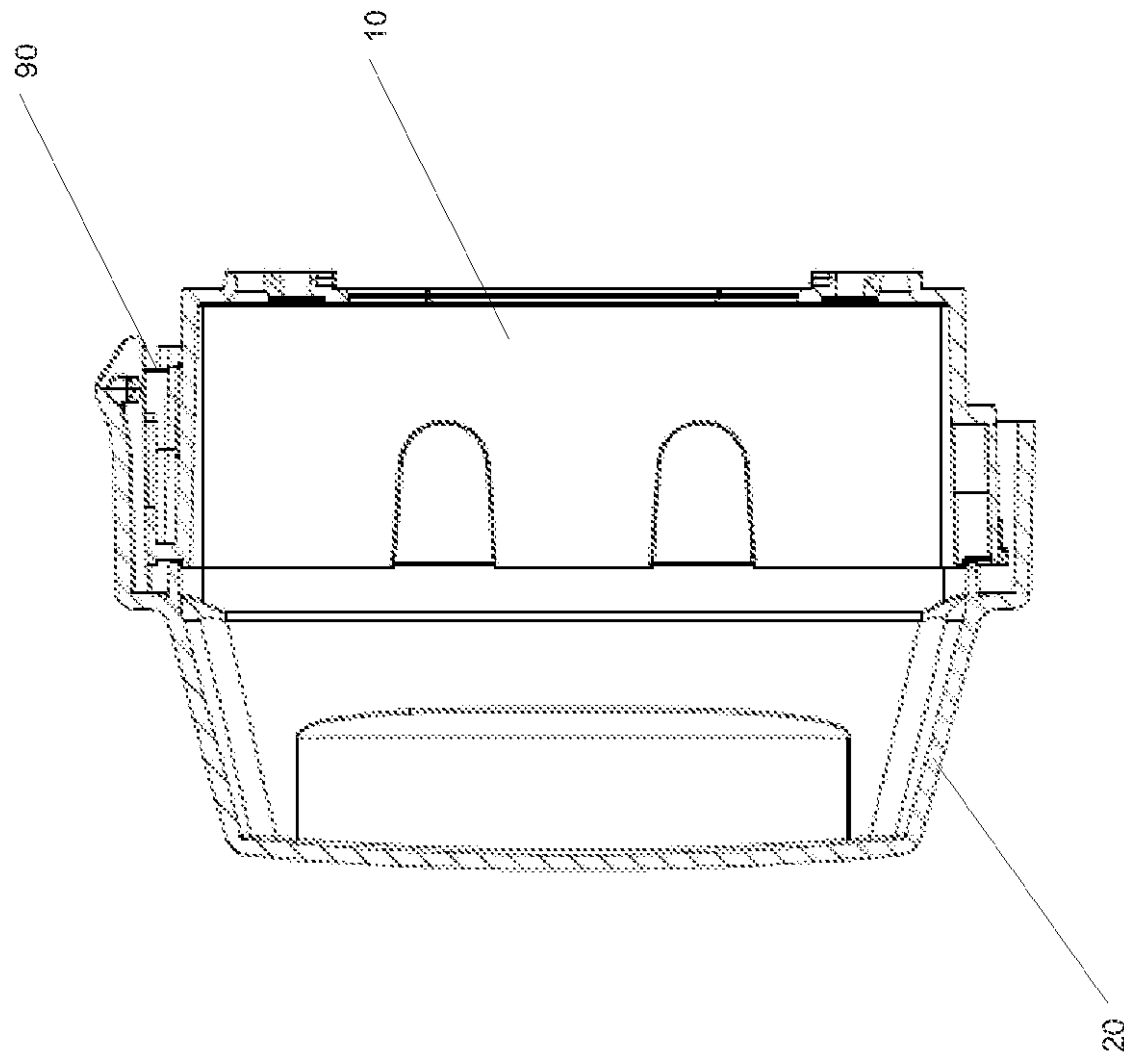

FIG. 8B

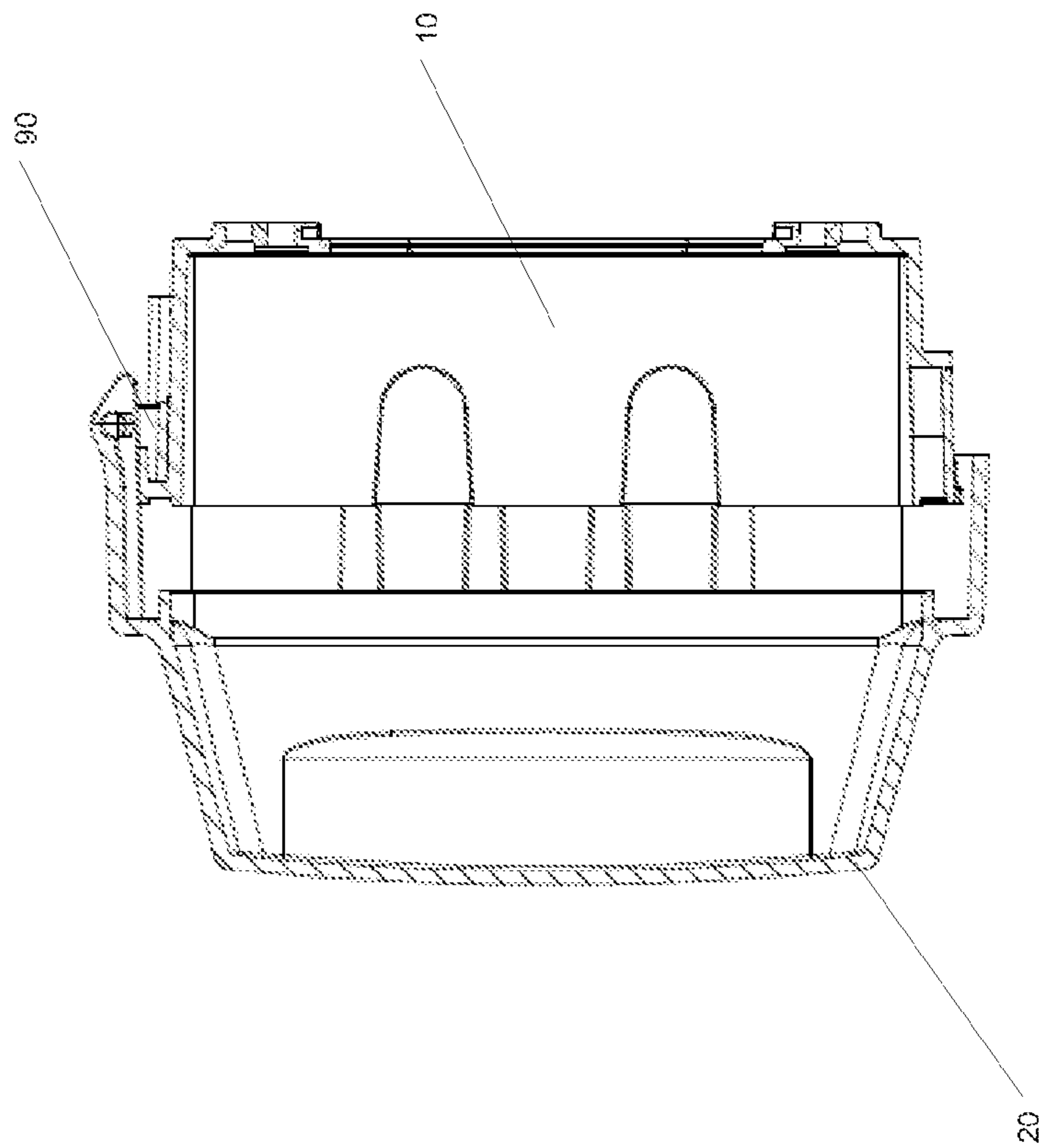

FIG. 8A

1

**APPARATUS AND METHOD FOR  
COLLAPSIBLE AND EXPANDABLE  
ELECTRICAL DEVICE COVER**

CROSS REFERENCE TO RELATED  
APPLICATIONS

This application is a continuation of the earlier patent application entitled "Apparatus and Method for Collapsible and Expandable Electrical Device Cover," Ser. No. 12/695,985 to Shotey et al., filed Jan. 28, 2010, now U.S. Pat. No. 8,106,295, issued Jan. 31, 2012, which claims the benefit of priority to U.S. provisional application Ser. No. 61/147,946 to Shotey et al., entitled "Collapsible/Expandable Cover," filed Jan. 28, 2009, the disclosures of which are hereby incorporated herein by reference.

BACKGROUND

1. Technical Field

Aspects of this document relate generally to electrical device covers.

2. Description of Related Art

Electrical device covers are conventionally used to protect electrical devices from water and other contaminants, prevent access to electrical wires, and/or provide a particular decorative look to an installed electrical device. Conventional electrical device covers may include a variety of components, such as bases and lids, and may be mounted in a variety of orientations, such as horizontal or vertical. Electrical device covers may be used in a variety of locations, including interior/exterior walls or recessed within a wall or other structure.

SUMMARY

In an aspect, an electrical device cover may comprise a base having a wall structure comprised of at least a first pair of opposing walls and a second pair of opposing walls located perpendicular to the first pair of opposing walls and an opening in a back side large enough to receive an electrical device. The device further comprises at least one rail on an exterior surface of at least one of the first pair of opposing walls, the at least one rail running perpendicular to a plane in which the back side of the base resides and a detachable hinge component having a base that is slidably coupled to at least one of the rails, the detachable hinge component further comprising at least one hinge member that is parallel to the base of the hinge component. A lid comprises at least one hinge tab in which the at least one hinge member seats such the lid is pivotally coupled to the hinge component.

Particular implementations may include one or more of the following. At least one stop on an exterior surface of the at least one of the first pair of opposing walls may run parallel to a plane in which the back side of the base resides. When the base of the detachable hinge component is slidably coupled to the at least one rail and rests against a front lip of the base, the lid is pivotable through the hinge member with respect to the base between an open position and an expanded closed position. When the base of the detachable hinge component is slidably coupled to the at least one rail and located in a proximal position relative to the back side of the base of the electrical device cover, the lid is pivotable through the hinge member with respect to the base between an open position and a collapsed closed position.

The electrical device cover may further comprise at least one rail on an exterior surface of at least one of the second pair of opposing walls, the at least one rail running perpendicular

2

to the plane in which the back side of the base resides. When the base of the detachable hinge component is slidably coupled to the at least one rail and rests against a front lip of the base, the lid is pivotable through the hinge member with respect to the base between an open position and an expanded closed position.

The lid may further comprise a latch component that mates with a latch component on the base to secure the lid in a closed position.

When the base of the detachable hinge component is slidably coupled to the at least one rail on the outer surface of one of the first pair of opposing walls and the detachable hinge member is located between the front lip of the base and the plane in which the back side of the base resides, the lid is pivotable through the hinge member with respect to the base between an open position and a closed position that is between an expanded closed position and a collapsed closed position. When the base of the detachable hinge component is slidably coupled to the at least one rail on the outer surface of one of the second pair of opposing walls and the detachable hinge member is located between the front lip of the base and the plane in which the back side of the base resides, the lid is pivotable through the hinge member with respect to the base between an open position and a closed position that is between an expanded closed position and a collapsed closed position.

When the base of the detachable hinge component is slidably coupled to two rails on the outer surface of one of the first pair of opposing walls, the lid is pivotable through the hinge member with respect to the base between an open position and a closed position that is between an expanded closed position and a collapsed closed position. When the base of the detachable hinge component is slidably coupled to two rails on the outer surface of one of the second pair of opposing walls, the lid is pivotable through the hinge member with respect to the base between an open position and a closed position that is between an expanded closed position and a collapsed closed position.

In another aspect, an electrical device cover, comprises a base having a wall structure comprised of at least a first pair of opposing walls and a second pair of opposing walls located perpendicular to the first pair of opposing walls and an opening in a back side large enough to receive an electrical device. The device cover further comprises at least a first rail on an exterior surface of at least one of the first pair of opposing walls, the at least first rail running perpendicular to a plane in which the back side of the base resides and at least a second rail on an exterior surface of at least one wall that is perpendicular to the at least one of the first pair of opposing walls, the at least second rail running perpendicular to a plane in which the back side of the base resides. The device further comprises a detachable hinge component having a base that is slidably couplable to the least first rail and the at least second rail, the detachable hinge component further comprising at least one hinge member that is parallel to the base of the hinge component and a lid comprising at least one hinge tab in which the at least one hinge member seats such the lid is pivotally coupled to the hinge component.

Particular implementations may include one or more of the following. When the base of the detachable hinge component is slidably coupled to the at least first rail of the at least one of the first pair of opposing walls and the hinge component is located proximal relative to the front lip of the base, the lid is pivotable through the hinge member with respect to the base between a vertically expanded open position and an expanded closed position and when the base of the detachable hinge component is slidably coupled to at least the second rail of the



at least one of the second pair of opposing walls and the hinge component is located proximal relative to the front lip of the base, the lid is pivotable through the hinge member with respect to the base between a horizontally expanded open position and an expanded closed position. When the base of the detachable hinge component is slidably coupled to the at least first rail of the at least one of the first pair of opposing walls and located in a proximal position relative to the back side of the base of the electrical device cover, the lid is pivotable through the hinge member with respect to the base between a vertically collapsed open position and a collapsed closed position and when the base of the detachable hinge component is slidably coupled to the at least second rail of the at least one of the second pair of opposing walls and located in a proximal position relative to the back side of the base of the electrical device cover, the lid is pivotable through the hinge member with respect to the base between a horizontally collapsed open position and a collapsed closed position.

The lid further comprises a latching component that mates with a latch component on the base to secure the lid in a closed position. When the base of the detachable hinge component is slidably coupled to the at least first rail on the outer surface of one of the first pair of opposing walls, the lid is pivotable through the hinge member with respect to the base between an open position and a closed position that is between an expanded closed position and a collapsed closed position. When the base of the detachable hinge component is slidably coupled to the at least second rail on the outer surface of one of the second pair of opposing walls, the lid is pivotable through the hinge member with respect to the base between an open position and a closed position that is between an expanded closed position and a collapsed closed position. In another aspect, a method of adjustably covering an electrical receptacle comprises mounting a base of an electrical cover device to a wall surface, the base having at least one rail on an exterior surface of two perpendicular walls of the base that run perpendicular to the wall surface to which the base is mounted, securing a hinge component to the base by slidably coupling a base of a hinge component to at least one rail on a first perpendicular wall, and pivotally coupling a lid having at least one hinge tab to the hinge component by seating at least one hinge member of the hinge component within the at least one hinge tab such that the lid pivots between an expanded open position and an expanded closed position.

Particular implementations may include one or more of the following. The method may further comprise sliding the hinge component along the rail so that the hinge component is located in a proximal position relative to the back side of the base of the electrical device cover such that when the lid is pivotally coupled to the hinge component, the lid pivots between a collapsed open position and a collapsed closed position.

The method may further comprise slidably decoupling the base of the hinge component from the at least one rail on the first perpendicular wall, slidably coupling the base of the hinge component to the at least one rail on the second perpendicular wall, and pivotally coupling the lid to the hinge component such that the lid pivots between an expanded open position and an expanded closed position. The method may further comprise sliding the hinge component along the rail so that the hinge component is located in a proximal position relative to the back side of the base of the electrical device cover such that when the lid is pivotally coupled to the hinge component, the lid pivots between a collapsed open position and a collapsed closed position.

The method may also further comprise securing the lid to the base by mating a latch component on the lid with a latch

component on the base. Aspects and applications presented here are described below in the drawings and detailed description. Unless specifically noted, it is intended that the words and phrases in the specification and the claims be given their plain, ordinary, and accustomed meaning to those of ordinary skill in the applicable arts. The inventors are fully aware that they can be their own lexicographers if desired. The inventors expressly elect, as their own lexicographers, to use only the plain and ordinary meaning of terms in the specification and claims unless they clearly state otherwise and then further, expressly set forth the "special" definition of that term and explain how it differs from the plain and ordinary meaning. Absent such clear statements of intent to apply a "special" definition, it is the inventors' intent and desire that the simple, plain and ordinary meaning to the terms be applied to the interpretation of the specification and claims.

The inventors are also aware of the normal precepts of English grammar. Thus, if a noun, term, or phrase is intended to be further characterized, specified, or narrowed in some way, then such noun, term, or phrase will expressly include additional adjectives, descriptive terms, or other modifiers in accordance with the normal precepts of English grammar. Absent the use of such adjectives, descriptive terms, or modifiers, it is the intent that such nouns, terms, or phrases be given their plain, and ordinary English meaning to those skilled in the applicable arts as set forth above.

Further, the inventors are fully informed of the standards and application of the special provisions of 35 U.S.C. §112, ¶6. Thus, the use of the words "function," "means" or "step" in the Detailed Description or Description of the Drawings or claims is not intended to somehow indicate a desire to invoke the special provisions of 35 U.S.C. §112, ¶6, to define the invention. To the contrary, if the provisions of 35 U.S.C. §112, ¶6 are sought to be invoked to define the inventions, the claims will specifically and expressly state the exact phrases "means for" or "step for, and will also recite the word "function" (i.e., will state "means for performing the function of [insert function]"), without also reciting in such phrases any structure, material or act in support of the function. Thus, even when the claims recite a "means for performing the function of . . ." or "step for performing the function of . . .," if the claims also recite any structure, material or acts in support of that means or step, or that perform the recited function, then it is the clear intention of the inventors not to invoke the provisions of 35 U.S.C. §112, ¶6. Moreover, even if the provisions of 35 U.S.C. §112, ¶6 are invoked to define the claims, it is intended that the disclosure not be limited only to the specific structure, material or acts that are described in the preferred embodiments, but in addition, include any and all structures, materials or acts that perform the claimed function as described in alternative embodiments or forms of the invention, or that are well known present or later-developed, equivalent structures, material or acts for performing the claimed function.

#### BRIEF DESCRIPTION OF THE DRAWINGS

A more complete understanding may be derived by referring to the detailed description when considered in connection with the following illustrative figures. In the figures, like reference numbers refer to like elements or acts throughout the figures.

The electrical device cover will hereinafter be described in conjunction with the appended drawings, where like designations denote like elements, and:

FIGS. 1A-1B depict a perspective view of an electrical cover device hinged in vertical expanded closed and open positions.



## 5

FIGS. 2A-2B depict a perspective view of an electrical cover device hinged in vertical collapsed closed and open positions.

FIGS. 3A-3B depict a perspective view of an electrical cover device hinged in horizontal expanded closed and open positions.

FIGS. 4A-4B depict a perspective view of an electrical cover device hinged in horizontal collapsed closed and open positions.

FIG. 5 depicts a hinge component.

FIG. 6 depicts a base of an electrical cover device.

FIGS. 7A-7B depict a horizontal base with a hinge component in two different positions.

FIGS. 8A-8B depict cross-sectional side views of an electrical cover device.

Elements and acts in the figures are illustrated for simplicity and have not necessarily been rendered according to any particular sequence or embodiment.

## DETAILED DESCRIPTION

In the following description, and for the purposes of explanation, numerous specific details are set forth in order to provide a thorough understanding of the various aspects and implementations of the apparatus and methods. It will be understood, however, by those skilled in the relevant arts, that the present disclosure may be practiced without these specific details. In other instances, known structures and devices are shown or discussed more generally in order to avoid obscuring the aspects of this disclosure. In many cases, a description of the operation is sufficient to enable one to implement the various forms of the disclosure. It should be noted that there are many different and alternative configurations, devices and technologies to which the disclosed aspects may be applied. The full scope of the disclosure is not limited to the examples that are described below

This disclosure, its aspects and implementations, are not limited to the specific components or assembly procedures disclosed herein. Many additional components and assembly procedures known in the art consistent with the intended operation and assembly procedures for an electrical device cover will become apparent for use with implementations of an electrical device cover from this disclosure. Accordingly, for example, although particular lids, bases, and hinge components are disclosed, such lids, bases, and hinge components and other implementing components may comprise any shape, size, style, type, model, version, measurement, concentration, material, quantity, and/or the like as is known in the art for such implementing components, consistent with the intended operation of an electrical device cover.

There are a variety of implementations of an electrical device cover assembly possible from the present disclosure. FIGS. 1A-8B illustrate some non-limiting examples of implementations of electrical device cover assemblies, but those of ordinary skill in the art will readily comprehend other particular implementations and variations from the disclosure provided in relation to the particular implementations provided here. Referring now to FIGS. 1A-4B, in one particular implementation, an electrical device cover 100 comprises a base 10 configured to mount to an electrical box. The base 10 comprises an opening in a back side 80 large enough to receive an electrical device, such as, by non-limiting example, an electrical outlet or switch of any of the conventional varieties found in the art. The base 10 also comprises a first pair of opposing walls 30, and a second pair of opposing walls 40 perpendicular to the first pair of opposing walls 30. Examples of structures and configurations that may be used to

## 6

enable electrical device covers to be interchangeably oriented horizontally or vertically while in use may be found in U.S. Pat. No. 7,071,415 to Shotey, et al. (issued Dec. 4, 2007) entitled "Horizontal and Vertical in-use Electrical Device Cover", the disclosure of which is hereby incorporated herein by reference for its descriptions relating to while-in-use electrical device covers. The exterior surfaces of at least one base wall includes one or more rails 50, grooves, or tracks (collectively "rails") that allow a detachable hinge component to slidably couple to the one or more rails. The rails 50 run perpendicular to the plane of the back side 80 of the base 10. Instead of, or in addition to, rails near the edges of the walls 30 and 40, it is contemplated that one or more rails may run near the center of the wall and fit into a track within the detachable hinge component.

The detachable hinge component 90 has a base 110 and at least one hinge member 70 that is located parallel to the base of the detachable hinge component 90. The device further comprises a lid 20 that has at least one hinge tab 60 into which the hinge members 70 seat so as to pivotally couple the base 110 of the hinge component 90 to the lid 20. FIGS. 1A, 1B, 3A, and 3B provide illustrative examples of the hinge component being slidably coupled to one or more rails 50 so that the base 110 of the hinge component 90 slides along the one or more rails 50 which form a track or slot into which the base 110 of the hinge component 90 is mounted or housed. When positioned between the two rails 50, in a position that is distal relative to the back side 80 and proximal to the front lip 85 of the base 10, the lid 20 is pivotally coupled to the hinge component 90 such that the lid pivots between an expanded closed position and an expanded open position. As shown in FIGS. 1A and 1B, the rails 50 to which the hinge component 90 is slidably coupled may be located on an exterior surface of a wall of a first pair of opposing walls 30 of the base so that the orientation of the cover device 100 is vertical. Also, as illustrated in FIGS. 3A and 3B, the rails 50 to which the hinge component 90 is slidably coupled may be located on an exterior surface of a wall of the second pair of opposing walls 40 of the base so that the orientation of the cover device 100 is horizontal.

FIGS. 2A, 2B, 4A, and 4B illustrate the detachable hinge component 90 being slidably coupled to a rail 50 located on the exterior surface of a wall of a second pair of opposing walls 40 and to the wall surface itself to which the cover device 100 is mounted. This placement of the hinge component in a location proximal relative to the back side 80 of the base allows the lid 20 and hinge component 90 to be pivotally coupled so that the lid 20 pivots between a collapsed closed position and a collapsed open position. As to the embodiments disclosed herein, one of ordinary skill in the art would recognize that the number of rails on any side of the base is not limited to one or two, but may be any number of rails 50 that would provide for useful positioning of the hinge component 90 so that the lid 20 pivots between an expanded or collapsed open position and any position that may be between expanded and collapsed closed positions. As shown in FIGS. 2A and 2B, the rails 50 to which the hinge component 90 is slidably coupled may be located on an exterior surface of a wall of a second pair of opposing walls 40 of the base so that the orientation of the cover device 100 is vertical. Also, as illustrated in FIGS. 4A and 4B, the rails 50 to which the hinge component 90 is slidably coupled may be located on an exterior surface of a wall of a second pair of opposing walls 40 of the base so that the orientation of the cover device 100 is horizontal.

The expanded closed position may be preferable when the electrical outlet is in use as this position allows for maximum



wire volume to pass through a cord port in the cover device **100**. When the outlet is not in use, however, it may be preferable to position the detachable hinge component **90** so that the lid **20** is in the collapsed closed position as this position provides a “low profile” so as to be less obtrusive by protruding a lesser distance from the wall surface.

FIG. **5** illustrates an implementation of a hinge component **90** having four hinge members **70** running parallel to the base **110** of the hinge component. Implementations need not be limited to four hinge members **70** as any number of hinge members **70** may be used, preferably a number equal to the number of hinge tabs **60** located on the lid **20**. Alternate hinge styles and types may also be used. Additionally, for the particular implementations shown, the barrel portion of the pin and barrel hinge style shown may be on the slidably detachable hinge component **90** and the pin portion on the lid if desired for a particular arrangement.

FIG. **6** depicts a rear view of the base **10** of an implementation of an electrical device cover **100**. As shown, the base **10** has rails **50** located on exterior surfaces of perpendicular walls of the base so that the hinge component **90** may be slidably detached from a proximal or distal position relative to the back side **80** of the base **10** so as to allow for closing in expanded and collapsed positions. This allows for ease of installation of the electrical device cover **100** as contractors need only bring one type of cover to installations in the field because once a determination is made as to whether a horizontal or vertical installation is preferable, the detachable hinge component **90** may be slidably coupled to one or more of the rails **50** to allow the cover to be installed with its desired orientation and remain so that gravity can cause the cover device **100** to move from an open to a closed position. It also allows the lid to swing closed from a collapsed or an expanded position. One or more stops **45** may be located between the front lip **45** and the back side **80** of the base on an exterior surface of the wall. The one or more stops **45** may run parallel to the plane in which the back side **80** of the base **10** resides, or may comprise just single point bumps at some point along the travel path for the hinge component **90**. The one or more stops **45** may provide slight resistance to indicate the preferred stopping point when the hinge component **90** is sliding along the rail **50**.

FIGS. **7A** and **7B** depict a rear view of a horizontally oriented base **10** of an electrical cover device **100**. FIG. **7A** shows a hinge component **90** slidably coupled in a proximal location relative to the back side **80** of the base **10** and FIG. **7B** shows a hinge component **90** slidably coupled in a distal location relative to the back side **80** of the base **10**. When a lid **20** (FIGS. **1-4**) is pivotally coupled through the hinge members **70** seating within the hinge tabs **60** of the lid **20**, i.e. the barrel portions of a pin and barrel hinge, this allows for the lid **20** to pivot between collapsed and expanded open, and collapsed and expanded closed positions.

FIGS. **8A** and **8B** provide a cross-sectional side view of an electrical device cover **100**, illustrating the difference in the distance that the lid **20** protrudes from the back side **80** of the base **10** for both distal (expanded closed position) and proximal (collapsed closed position) hinge component **90** placements, respectively. Thus, when the electrical outlet is not in use, the detachable hinge component **90** may be placed in its proximal (collapsed) position to minimize the cover’s protrusion from the wall surface.

Any of the implementations described herein may also include one or more locking or latching components (not shown) so that the lid **20** and base **10** may be latched together in any of the possible closed positions.

It will be understood that implementations are not limited to the specific components disclosed herein, as virtually any components consistent with the intended operation of a method and/or system implementation for an electrical device cover may be utilized. Accordingly, for example, although particular lids, hinges, and bases may be disclosed, such components may comprise any shape, size, style, type, model, version, class, grade, measurement, concentration, material, weight, quantity, and/or the like consistent with the intended operation of a method and/or system implementation for an electrical device cover.

The concepts disclosed herein are not limited to the specific implementations shown herein. For example, it is specifically contemplated that the components included in a particular implementation of an electrical device cover may be formed of any of many different types of materials or combinations that can readily be formed into shaped objects and that are consistent with the intended operation of an electrical device cover. For example, the components may be formed of: rubbers (synthetic and/or natural) and/or other like materials; polymers and/or other like materials; plastics, and/or other like materials; composites and/or other like materials; metals and/or other like materials; alloys and/or other like materials; and/or any combination of the foregoing.

Furthermore, the electrical device covers, lids, bases, removable tabs, adapters, hinges, cord ports, and electrical devices, and any other components forming a particular implementation of an electrical device cover may be manufactured separately and then assembled together, or any or all of the components may be manufactured simultaneously and integrally joined with one another. Manufacture of these components separately or simultaneously may involve extrusion, pultrusion, vacuum forming, injection molding, blow molding, resin transfer molding, casting, forging, cold rolling, milling, drilling, reaming, turning, grinding, stamping, cutting, bending, welding, soldering, hardening, riveting, punching, plating, and/or the like. If any of the components are manufactured separately, they may then be coupled or removably coupled with one another in any manner, such as with adhesive, a weld, a fastener, any combination thereof, and/or the like for example, depending on, among other considerations, the particular material(s) forming the components.

In places where the description above refers to particular implementations of an electrical device cover, it should be readily apparent that a number of modifications may be made without departing from the spirit thereof and that these implementations may be applied to other electrical device covers. The accompanying claims are intended to cover such modifications as would fall within the true spirit and scope of the disclosure set forth in this document. The presently disclosed implementations are, therefore, to be considered in all respects as illustrative and not restrictive, the scope of the disclosure being indicated by the appended claims rather than the foregoing description. All changes that come within the meaning of and range of equivalency of the claims are intended to be embraced therein.

We claim:

1. An electrical device cover system, comprising:
  - a base comprising two or more side walls adjacent one another and extending from a back wall to an open front, the back wall comprising an opening large enough to receive an electrical device;
  - two rails positioned substantially perpendicular to the back wall on an exterior surface of a first of said two or more side walls;



9

a detachable hinge component comprising at least one hinge member and a hinge base sized to slidably mount between the two rails; and  
 a lid comprising at least one hinge tab sized to seat the at least one hinge member and pivotally couple the lid to the base when the hinge base is slidably mounted between the two rails and the at least one hinge member is seated within the at least one hinge tab.

2. The electrical device cover system of claim 1, wherein: the two or more side walls comprises at least four side walls; and  
 said system further comprises two rails positioned perpendicular to the back wall on a second side wall of the four side walls; and  
 the hinge base is sized to slidably mount between the two rails on the first side wall and sized to slidably mount between the two rails on the second side wall.

3. The electrical device cover system of claim 2, further comprising at least one stop positioned between the two rails on the first side wall and at least one stop positioned between the two rails on the second side wall.

4. The electrical device cover system of claim 3, wherein the at least one stop positioned between the two rails on the first side wall comprises two stops, and  
 the at least one stop positioned between the two rails on the second side wall comprises two stops.

5. The electrical device cover system of claim 4, wherein the two stops on the first side wall comprise an elongated stop extending substantially parallel to a plane of the back wall, and  
 the two stops on the second side wall comprises an elongated stop extending substantially parallel to the plane of the back wall.

6. The electrical device cover system of claim 5, wherein the hinge component comprises four hinge members, and the at least one hinge tab of said lid comprises four hinge tabs, the four hinge members each comprising a pin sized to fit at least partially in a respective hinge tab.

7. The electrical device cover of claim 6, wherein  
 a first stop of the two stops on the first side wall is positioned to stop the hinge base between the open front and the first stop, and a second stop of the two stops of the first side wall is positioned to stop the hinge base between the first stop and the second stop, and  
 a first stop of the two stops on the second side wall is positioned to stop the hinge base between the open front and the first stop, and a second stop of the two stops of the second wall is positioned to stop the hinge base between the first stop and the second stop.

8. An electrical device cover, comprising:  
 a base comprising a first side wall and a second side wall adjacent one another and extending from a back wall to an open front, the back wall comprising an opening large enough to receive an electrical device;  
 two rails positioned perpendicular to the back wall on an exterior surface of said first side wall;  
 two rails positioned perpendicular to the back wall on an exterior surface of said second side wall;  
 a detachable hinge component slidably coupled either between the two rails on the first side wall or between the two rails on the second side wall; and  
 a lid pivotally coupled to the hinge component.

9. The electrical device cover of claim 8, wherein:  
 the base comprises four side walls;  
 the detachable hinge component comprises at least one hinge member and a hinge base, the hinge base slidably

10

coupled between either the two rails on the first side wall or between the two rails on the second side wall; and  
 the lid comprises at least one hinge tab, the at least one hinge member seated within the at least one hinge tab to pivotally couple the lid to the hinge component.

10. The electrical device cover of claim 9, further comprising at least one stop positioned between the two rails on the first side wall, and at least one stop positioned between the two rails on the second side wall.

11. The electrical device cover of claim 10, wherein the at least one stop positioned between the two rails on the first side wall comprises a first stop and a second stop, and at least one stop positioned between the two rails on the second side wall comprises a first stop and a second stop.

12. The electrical device cover of claim 11, wherein the first stop on the first side wall and the second side wall is positioned to stop the hinge base between the open front and the first stop, and the second stop on the first side wall and on the second side wall is positioned to stop the hinge base between the respective first stop and the second stop.

13. The electrical device cover system of claim 12, wherein the stops on the first side wall and on the second side wall comprise an elongated stop extending substantially parallel to a plane of the back wall.

14. The electrical device cover system of claim 13, wherein the at least one hinge member comprises four hinge members and the at least one hinge tab comprises four hinge tabs, the four hinge members each comprising a pin sized to fit at least partially one of the four hinge tabs.

15. A method of pivotally coupling a lid to an electrical device cover base, said electrical device cover base having two or more side walls adjacent one another and extending from a back wall to an open front, the back wall having an opening large enough to receive an electrical device, said method comprising

sliding a hinge component having at least one hinge member and a hinge base between two rails on an exterior surface of a first of said side walls of the electrical device cover base to removably couple the hinge component to the electrical device cover base; and

seating the hinge member extending from the hinge component within at least one hinge tab extending from the lid to pivotally couple to the electrical device cover base.

16. The method of claim 15, further comprising:  
 removing the hinge component from between the two rails on the exterior surface of the first side wall; and  
 sliding the hinge component between two rails on an exterior surface of a second of said side walls of the electrical device cover base to removably couple the hinge component to the electrical device cover base at the second side wall.

17. The method of claim 15, wherein the step of sliding the hinge component between the two rails on the exterior surface of the first of said side walls of the electrical device cover comprises

sliding the hinge component between the two rails on the exterior surface of the first of said side walls of the electrical device until the hinge component is positioned between a front lip on the electrical device cover base and a first elongated stop, the first elongated stop positioned between the two rails on the first of said side walls.

18. The method of claim 15, wherein the step of sliding the hinge component between the two rails on the exterior surface of the first of said side walls of the electrical device cover comprises

sliding the hinge component between the two rails on the exterior surface of the first of said side walls of the electrical device until the hinge component is positioned between a first elongated stop and a second elongated stop, each of the first and the second elongated stops positioned between the two rails on the first of said side walls. 5

**19.** The method of claim **15**, wherein the step of seating the at least one hinge member extending from the hinge component within the at least one hinge tab extending from the lid comprises 10

separately seating four hinge members extending from the hinge component within four hinge tabs extending from the lid.

**20.** The method of claim **15**, further comprising latching the lid to the electrical device cover base. 15

\* \* \* \* \*