



US008814417B2

(12) **United States Patent**
Ko et al.

(10) **Patent No.:** **US 8,814,417 B2**
(45) **Date of Patent:** **Aug. 26, 2014**

(54) **BACKLIGHT UNIT AND DISPLAY DEVICE USING THE SAME**

USPC 362/602, 608, 609, 612, 613, 97.1, 611
See application file for complete search history.

(71) Applicant: **LG Innotek Co., Ltd.**, Seoul (KR)

(56) **References Cited**

(72) Inventors: **Se Jin Ko**, Seoul (KR); **Ji In Lee**, Seoul (KR)

U.S. PATENT DOCUMENTS

(73) Assignee: **LG Innotek Co., Ltd.**, Seoul (KR)

(*) Notice: Subject to any disclaimer, the term of this patent is extended or adjusted under 35 U.S.C. 154(b) by 0 days.

5,008,658	A *	4/1991	Russay et al.	345/87
6,257,737	B1 *	7/2001	Marshall et al.	362/231
7,229,198	B2 *	6/2007	Sakai et al.	362/560
7,708,450	B2 *	5/2010	Mikami	362/632
8,235,540	B2 *	8/2012	Park et al.	362/97.1
2005/0185394	A1 *	8/2005	Sakamoto et al.	362/133
2006/0274550	A1	12/2006	Liu et al.	
2007/0014126	A1 *	1/2007	Kuo et al.	362/600
2007/0070623	A1 *	3/2007	Laski	362/235
2007/0171676	A1	7/2007	Chang	

(21) Appl. No.: **14/097,444**

(22) Filed: **Dec. 5, 2013**

OTHER PUBLICATIONS

(65) **Prior Publication Data**

European Search Report dated Nov. 2, 2012 issued in Application No. 12 15 3286.

US 2014/0092585 A1 Apr. 3, 2014

Related U.S. Application Data

* cited by examiner

(63) Continuation of application No. 13/363,052, filed on Jan. 31, 2012, now Pat. No. 8,616,754.

Primary Examiner — Ali Alavi

(74) *Attorney, Agent, or Firm* — KED & Associates, LLP

(30) **Foreign Application Priority Data**

Jul. 29, 2011 (KR) 10-2011-0075995

(57) **ABSTRACT**

(51) **Int. Cl.**
F21V 7/04 (2006.01)
F21V 7/00 (2006.01)

Disclosed is a backlight unit and a display device using the same, which includes a first reflector, a second reflector **300** and at least one light source module **100** disposed between the first and second reflectors, wherein a back surface of the first reflector comprises an inclined plane **201** and a flat surface **202**, with facing the second reflector, and the inclined plane is adjacent to the light source and the flat surface is extended from an end of the inclined plane, with the inclined plane and the flat surface being collinear.

(52) **U.S. Cl.**
CPC *F21V 7/00* (2013.01)
USPC **362/612**; 362/611; 362/608; 362/609; 362/97.1

(58) **Field of Classification Search**
CPC F21V 7/00; F21V 7/04

20 Claims, 20 Drawing Sheets

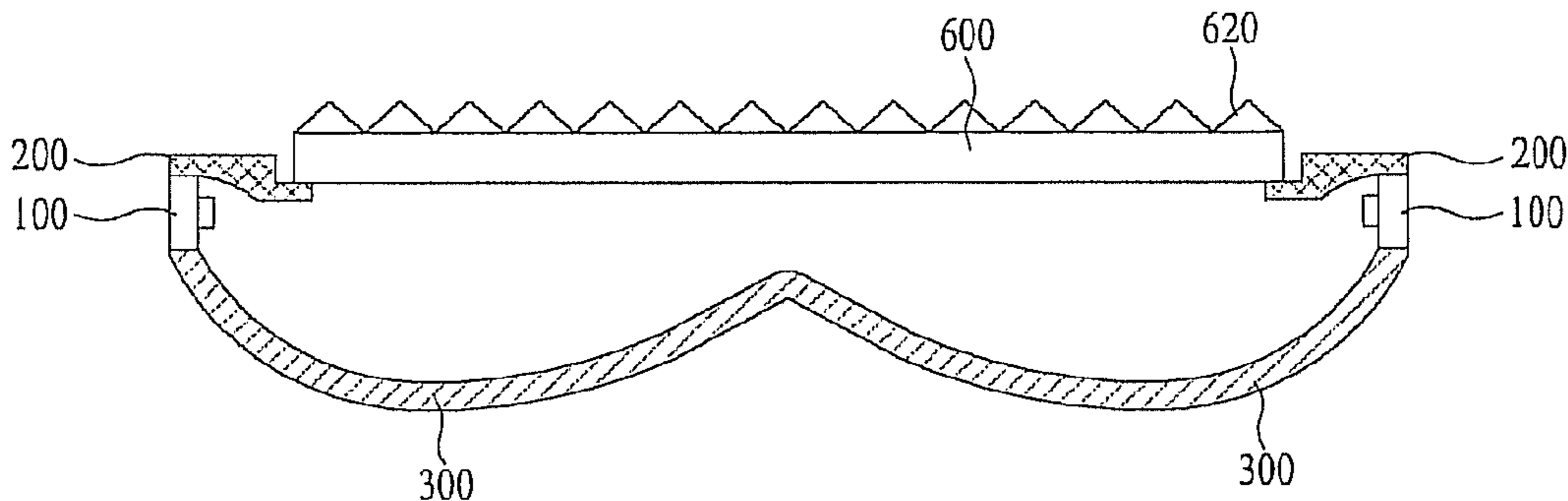

FIG. 1

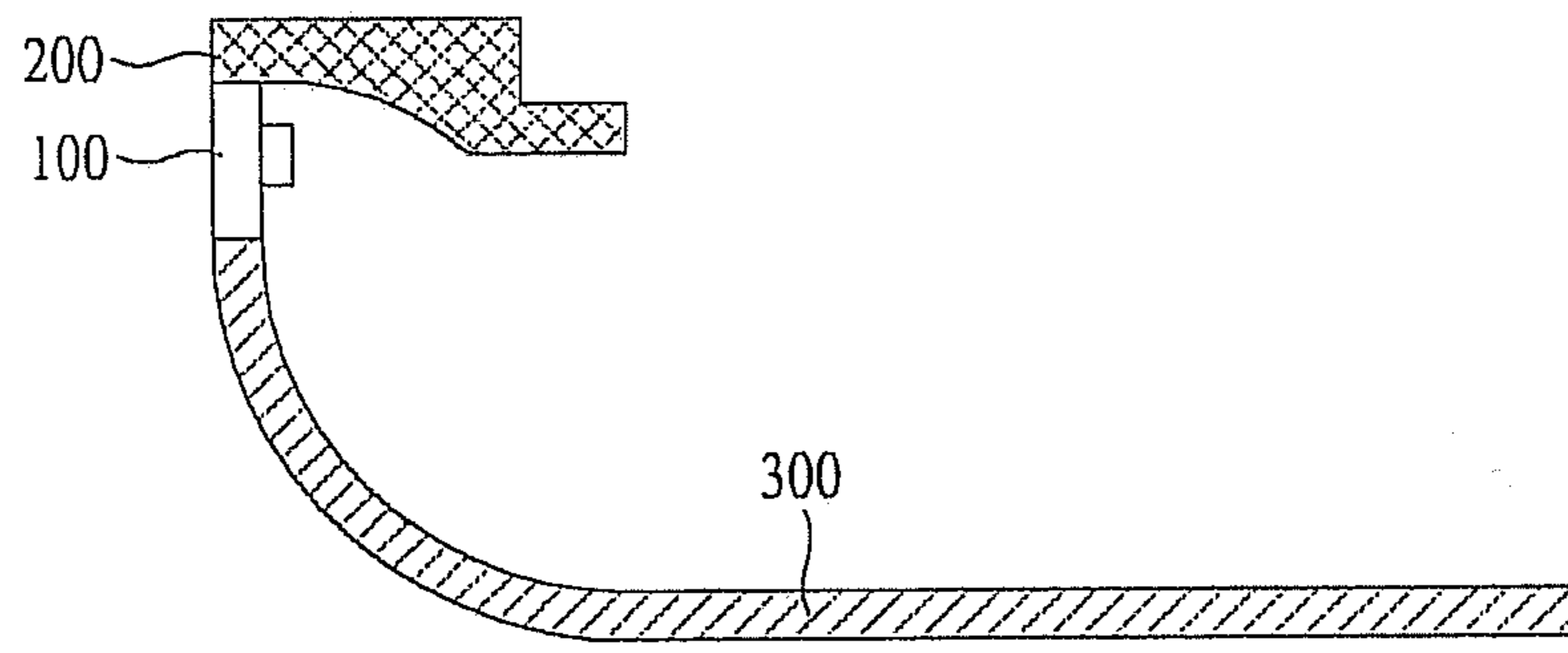

FIG. 2A

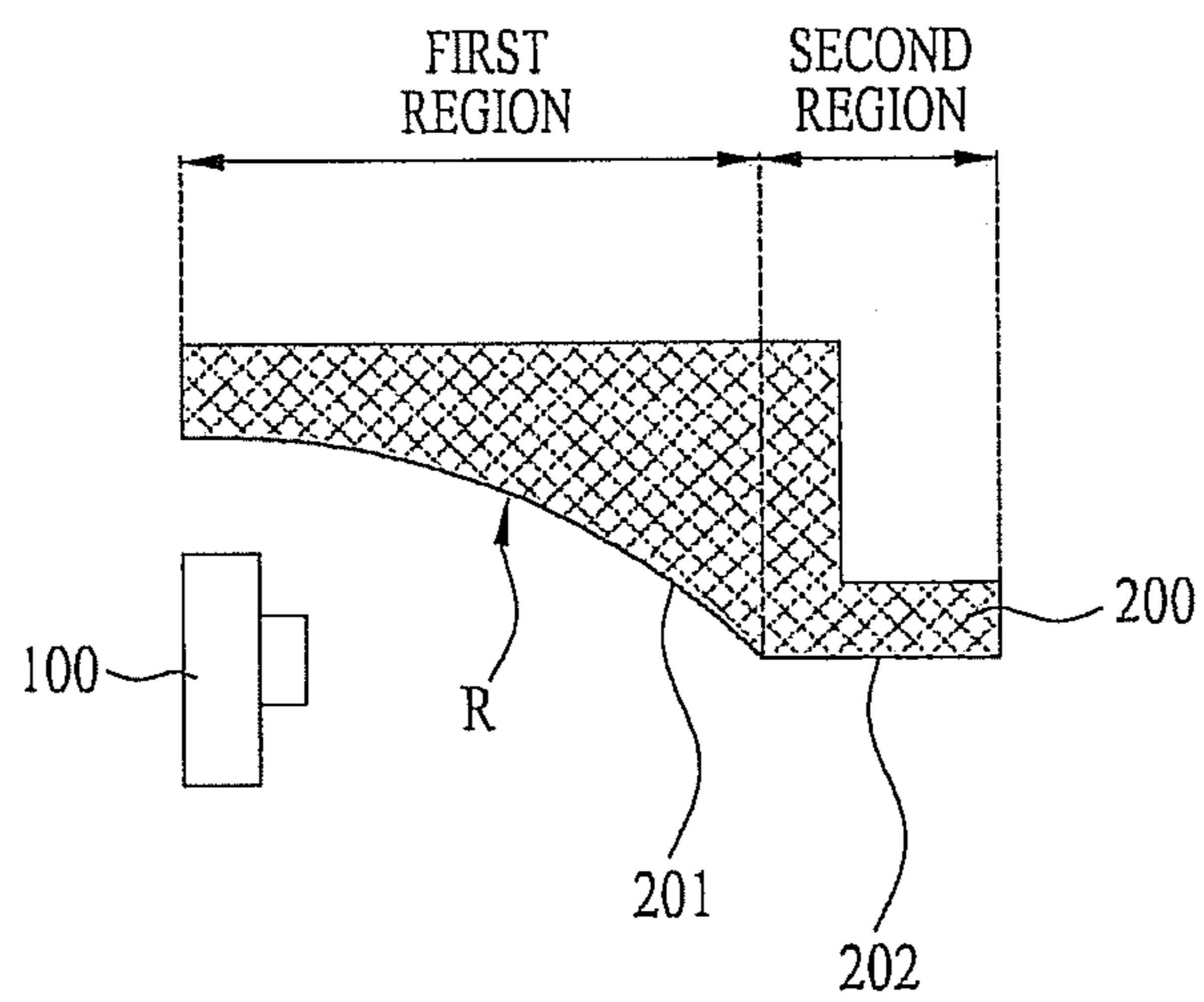

FIG. 2B

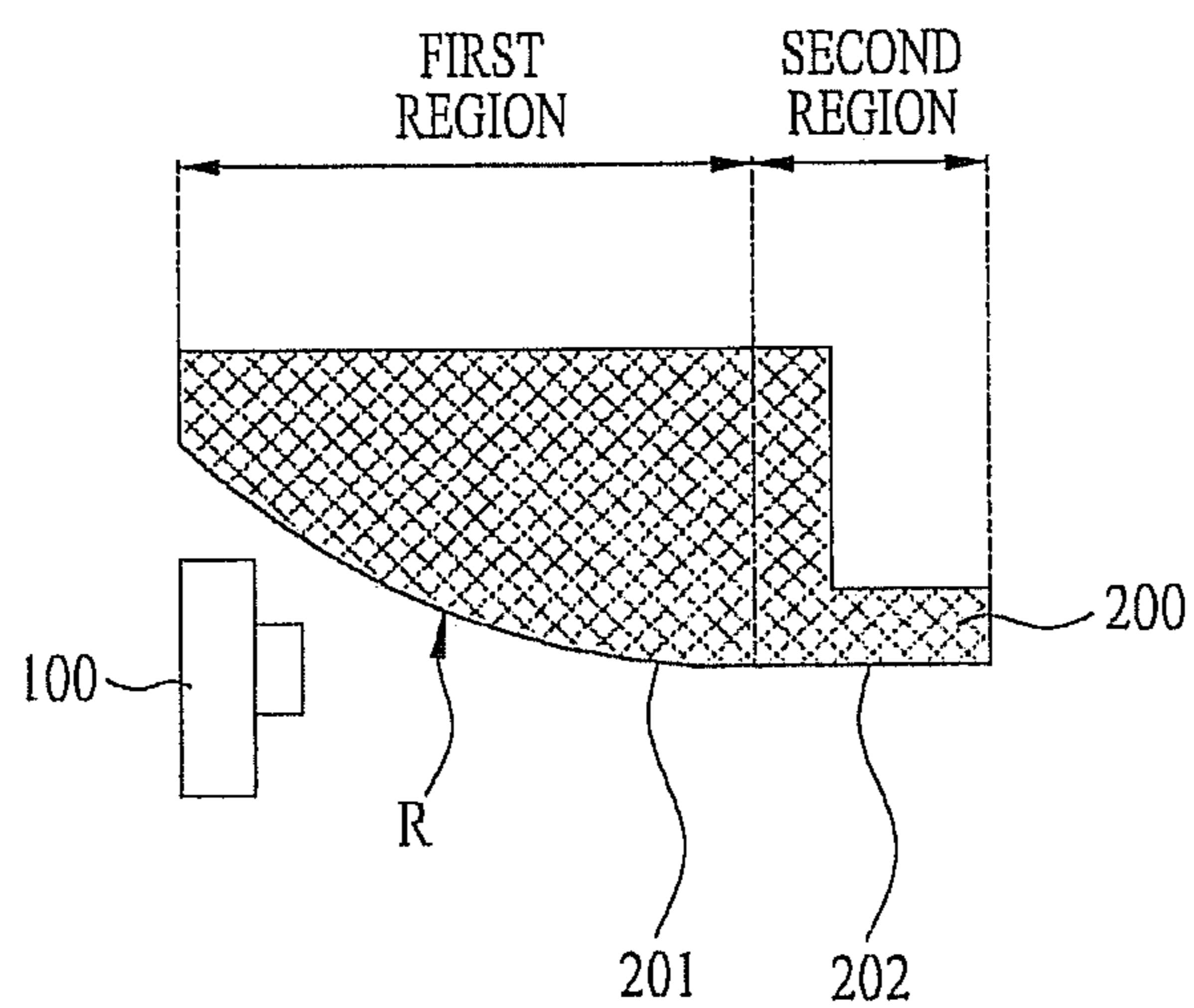

FIG. 2C

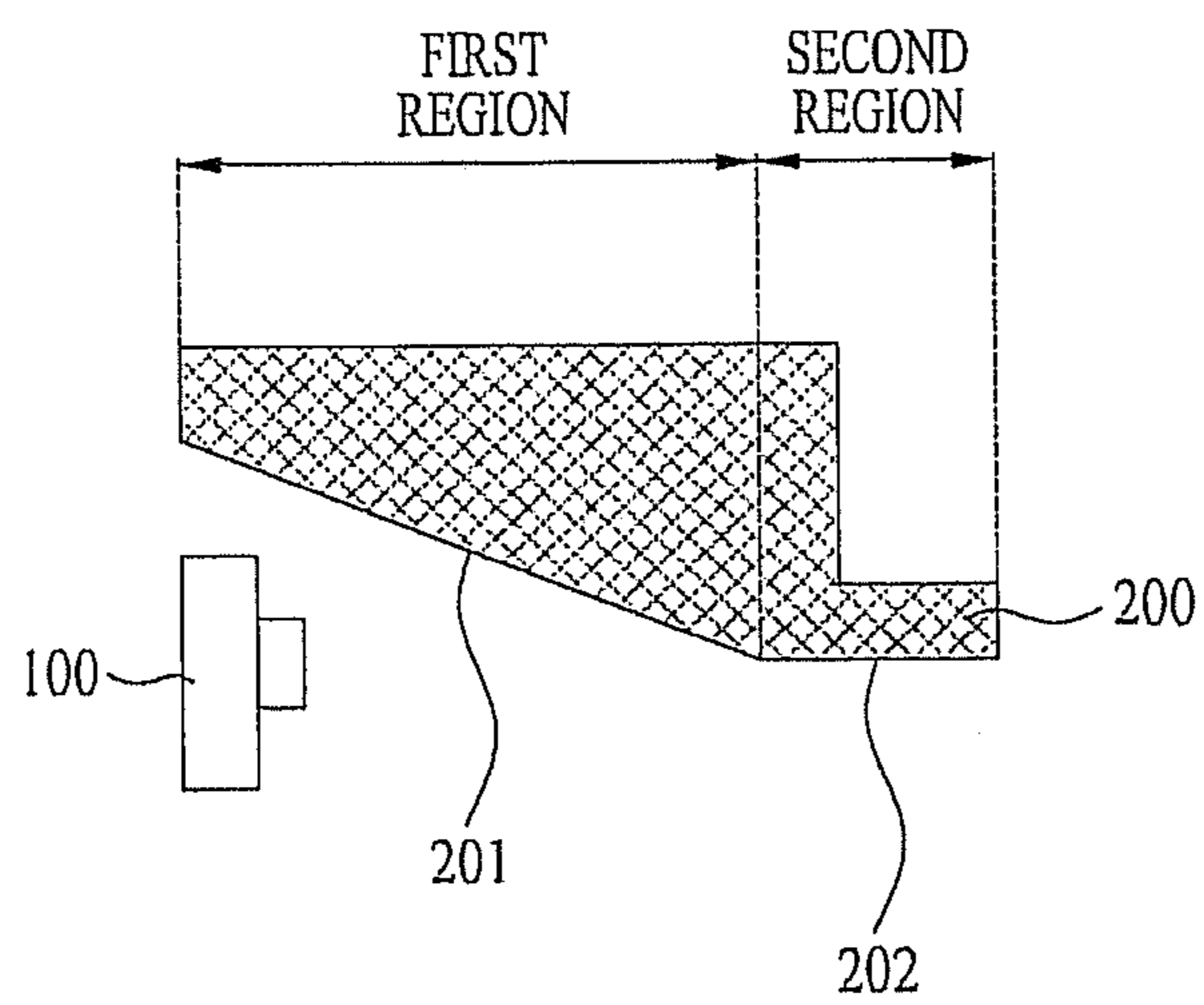

FIG. 3

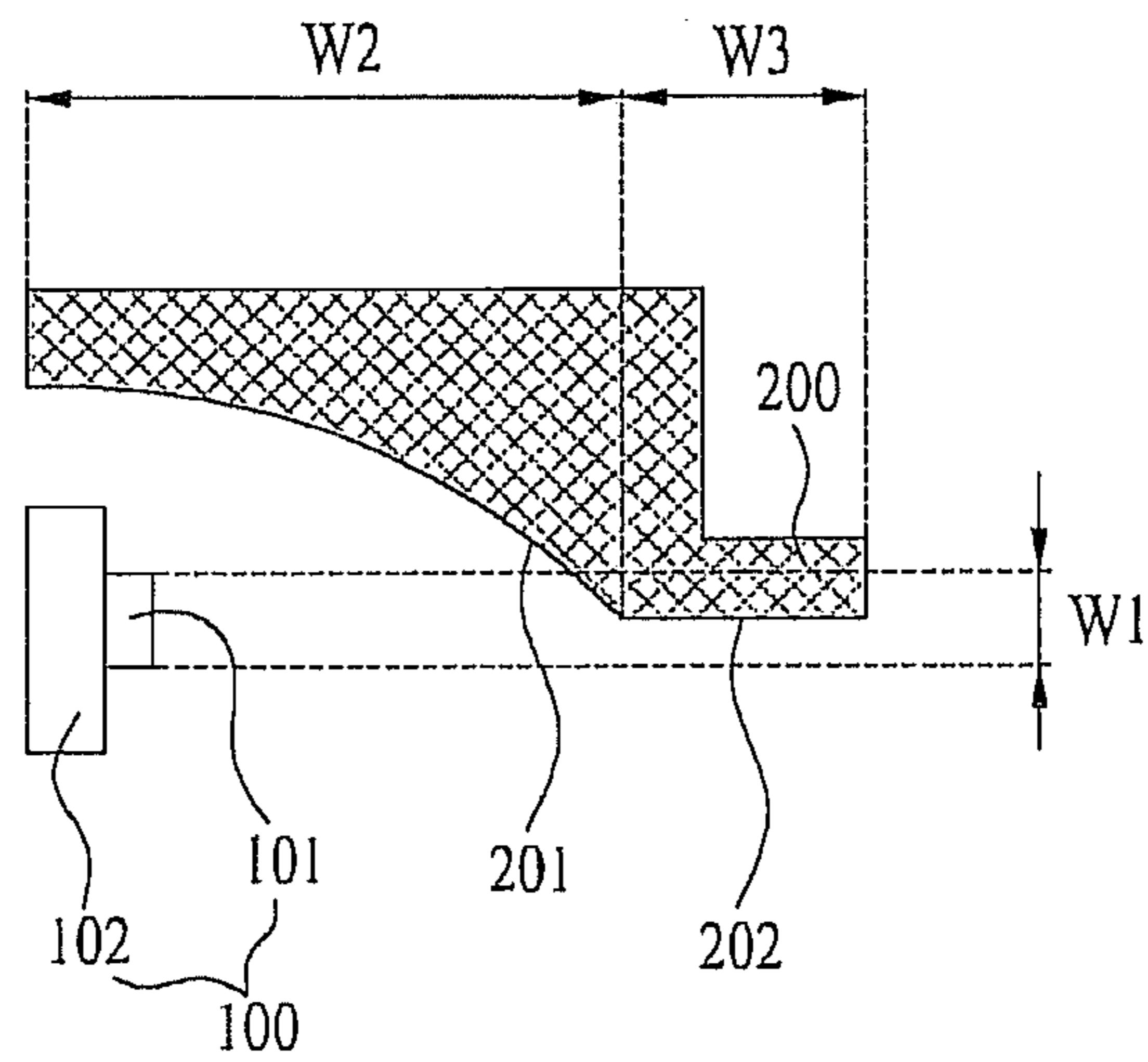

FIG. 4A

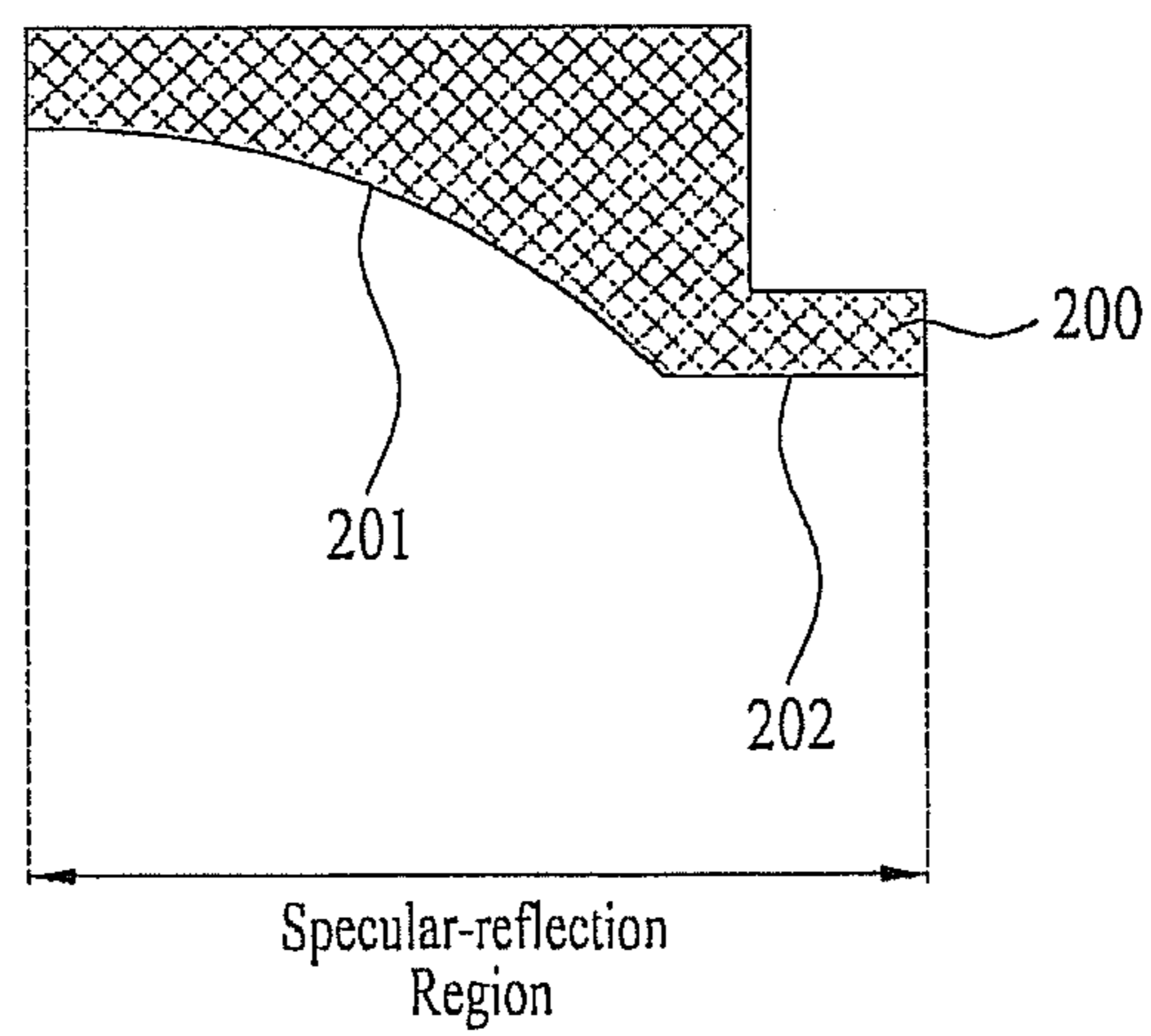

FIG. 4B

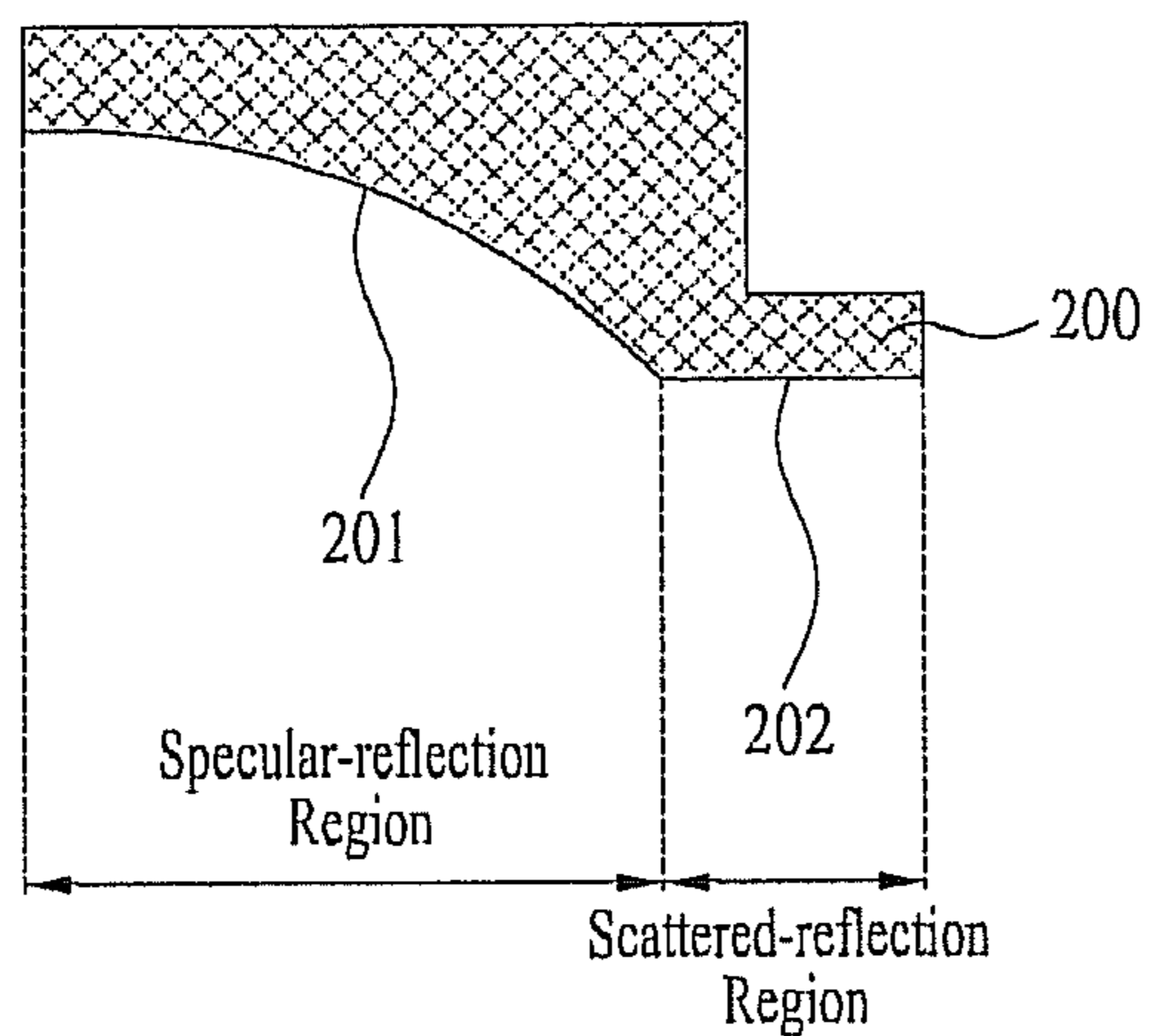

FIG. 4C

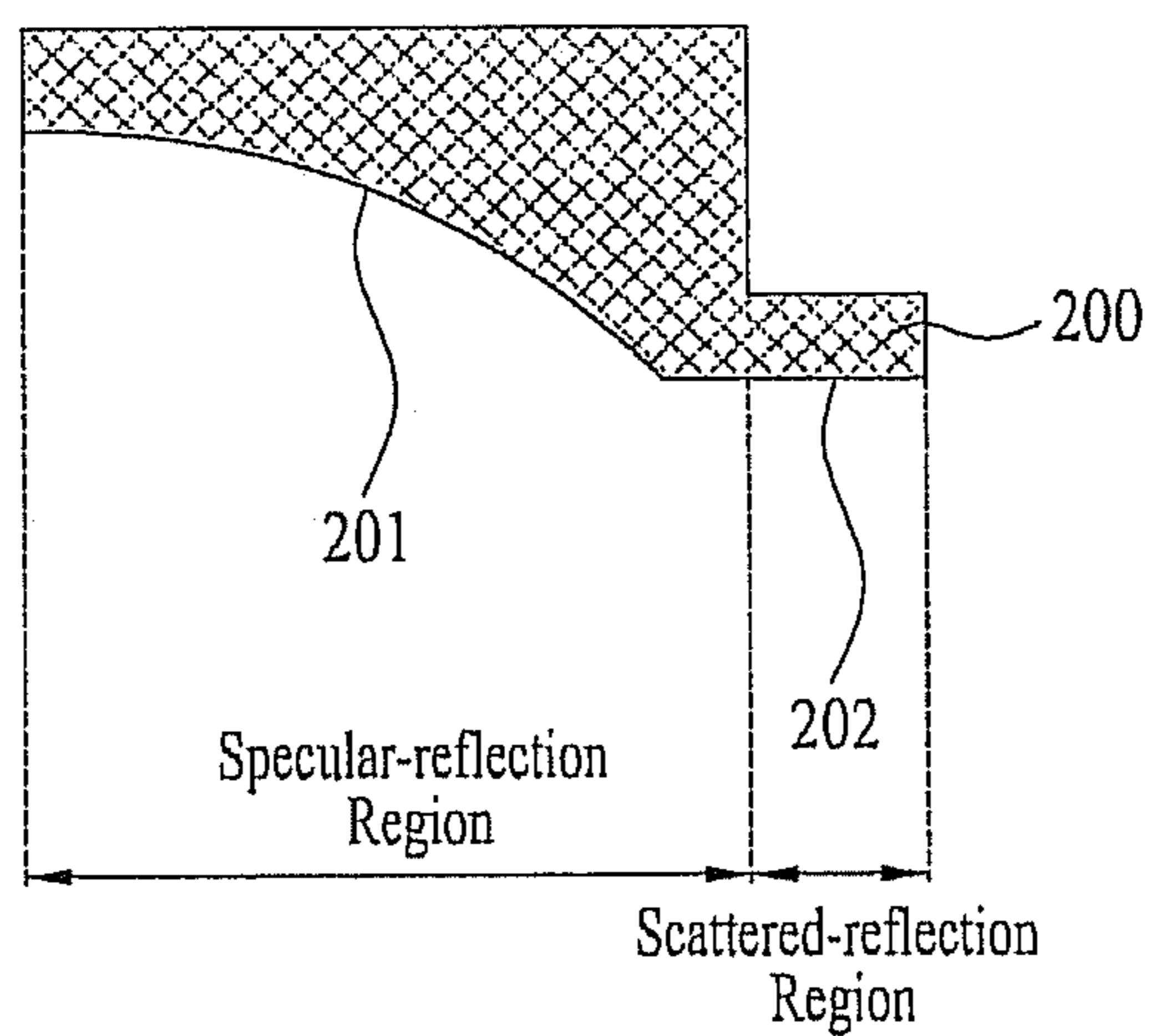

FIG. 5A

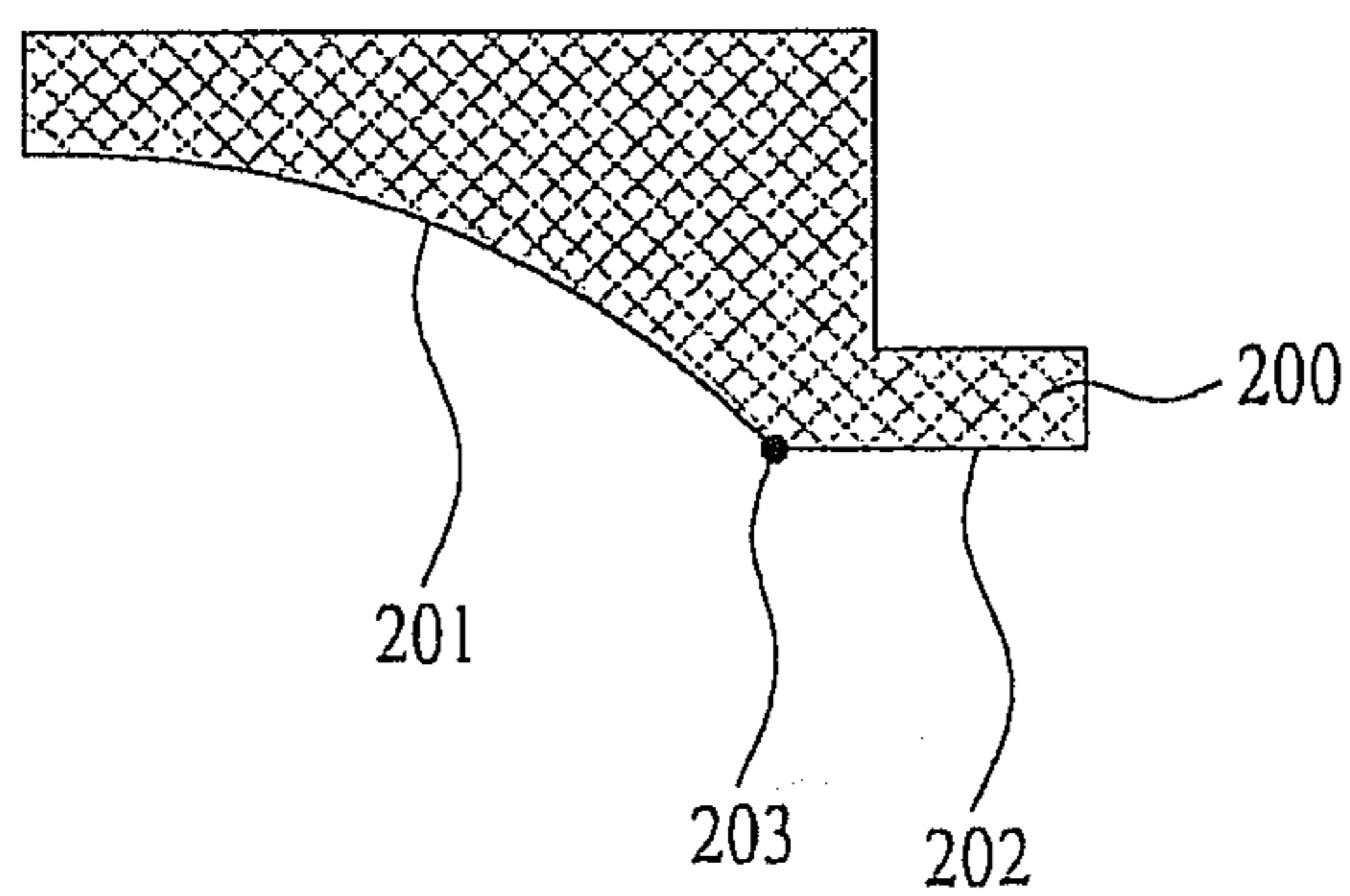

FIG. 5B

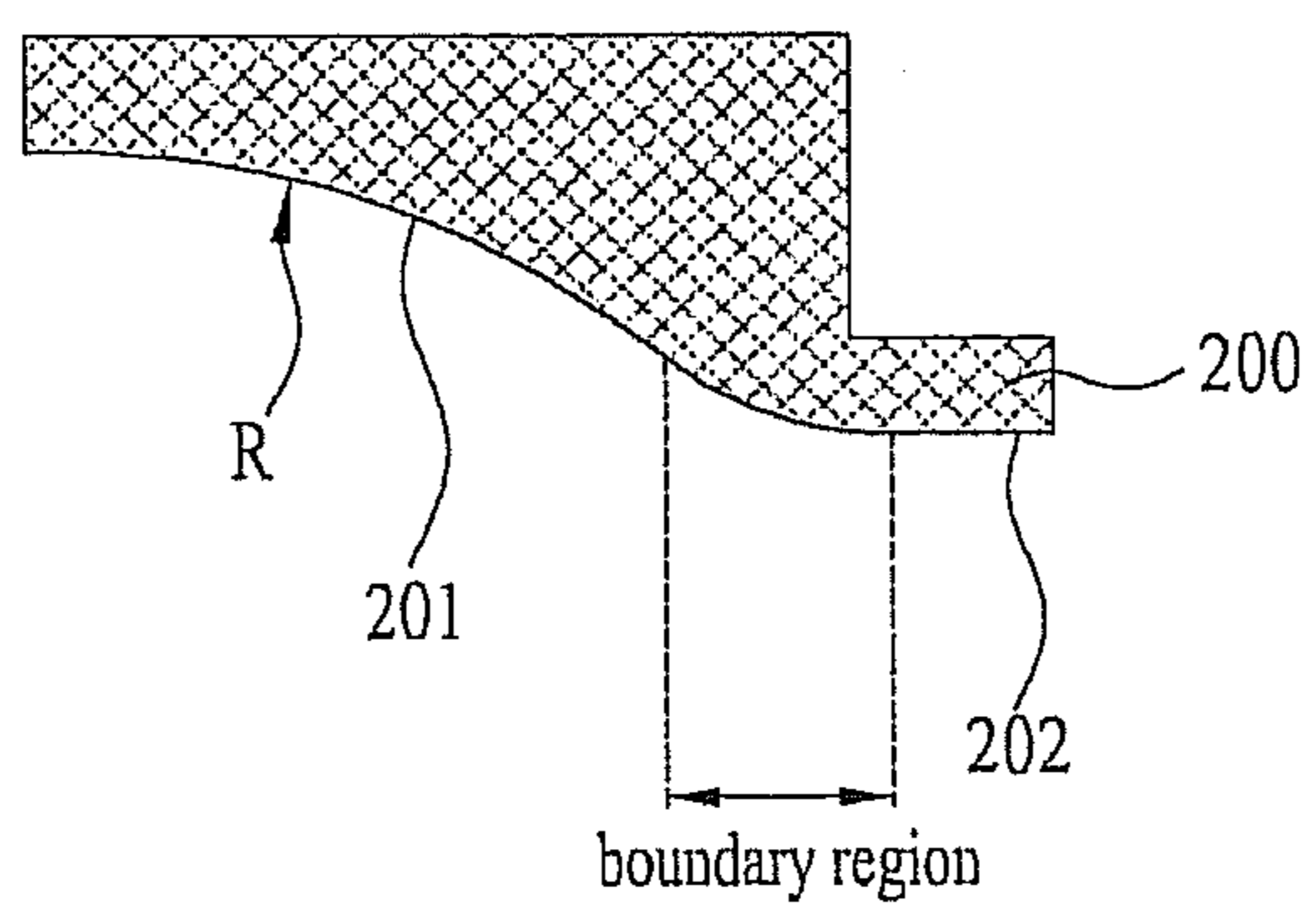

FIG. 6A

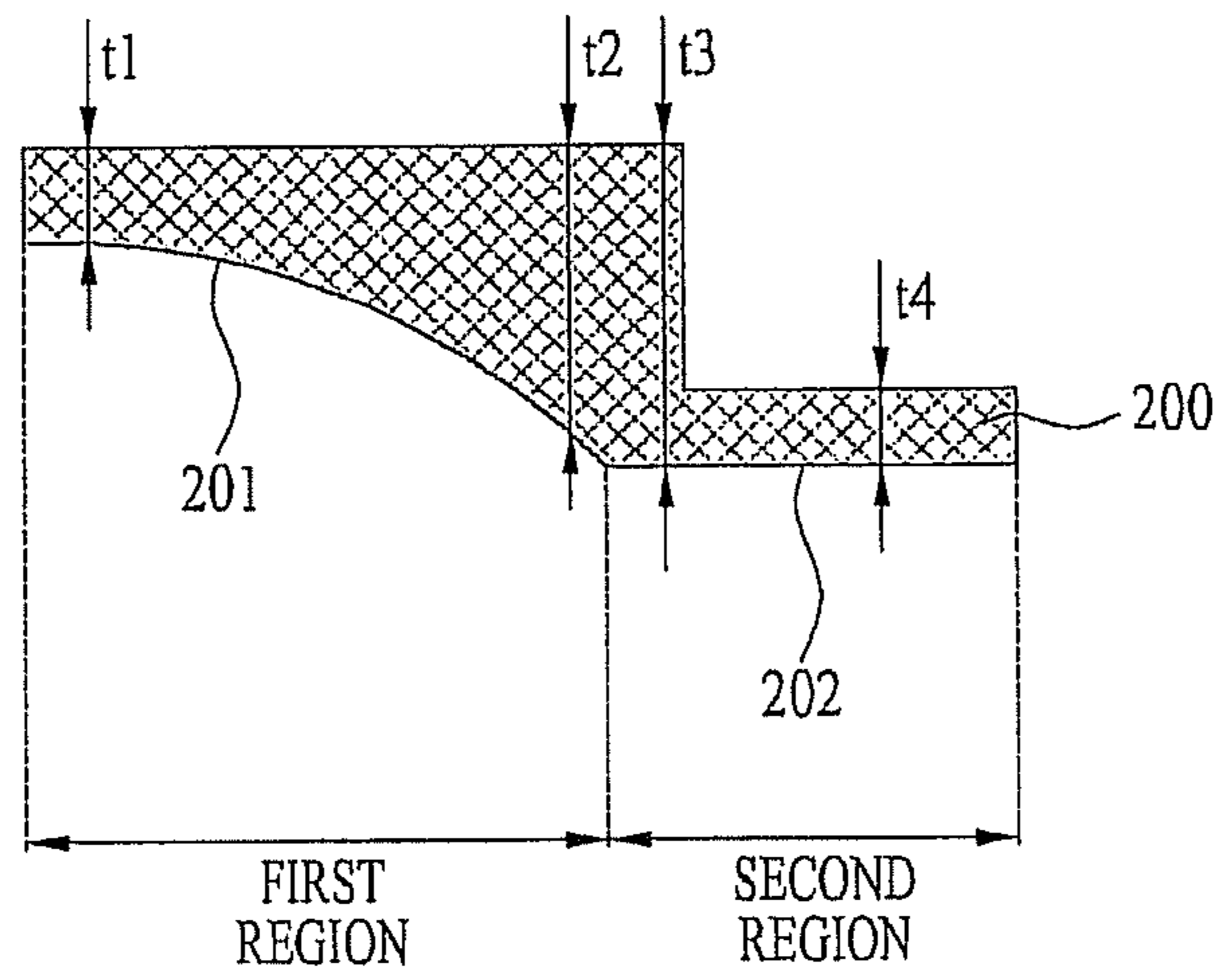

FIG. 6B

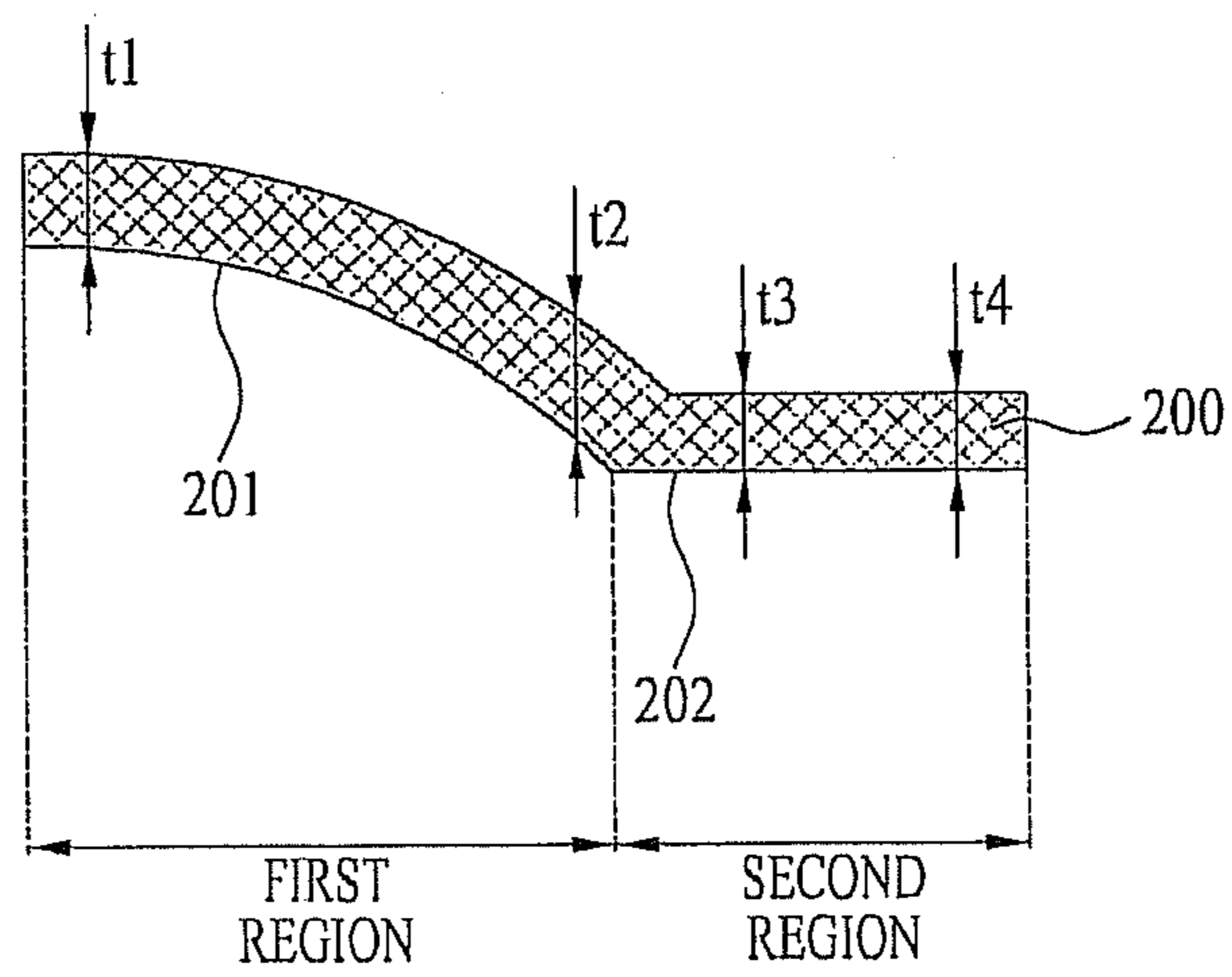

FIG. 7A

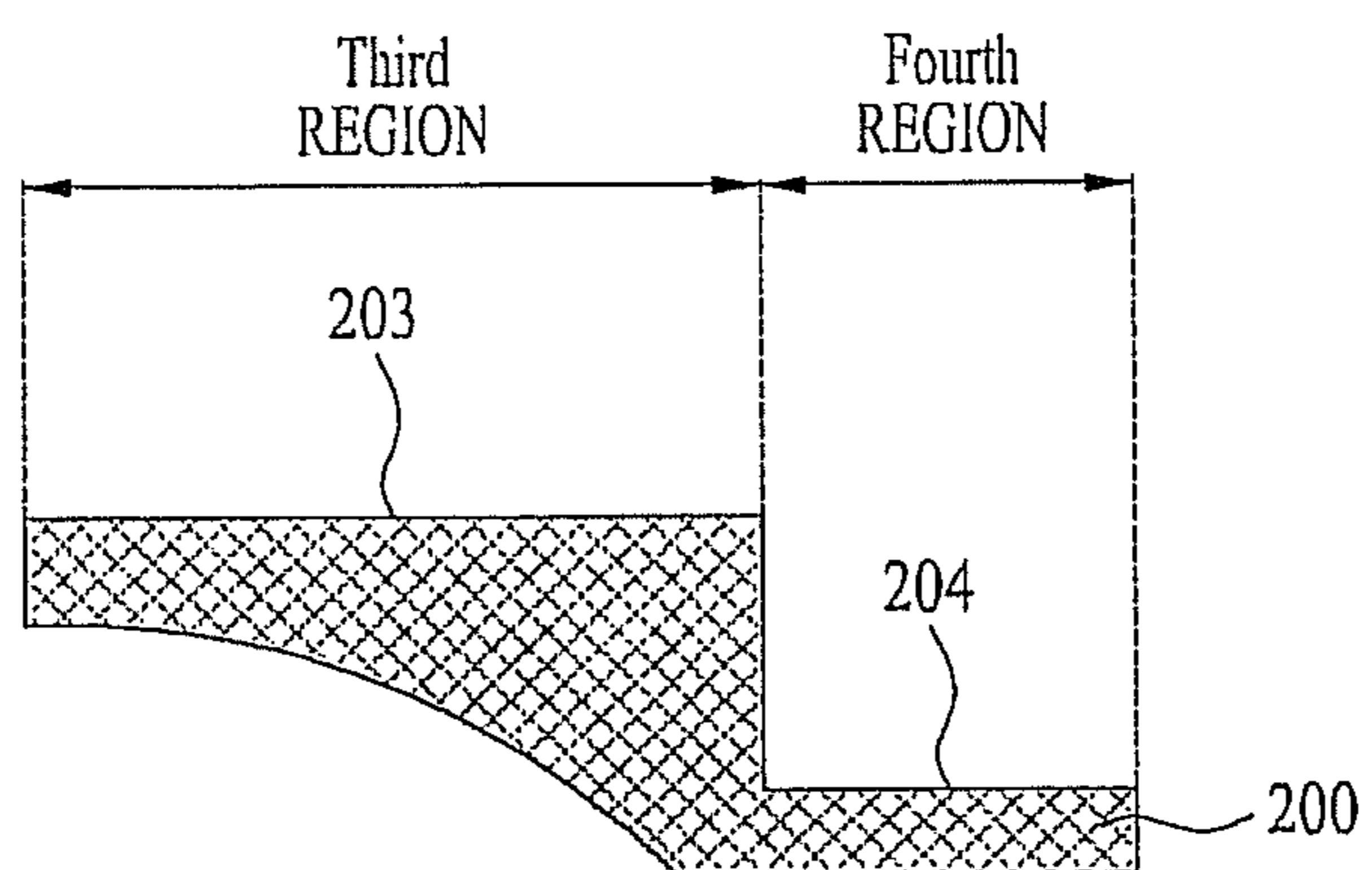

FIG. 7B

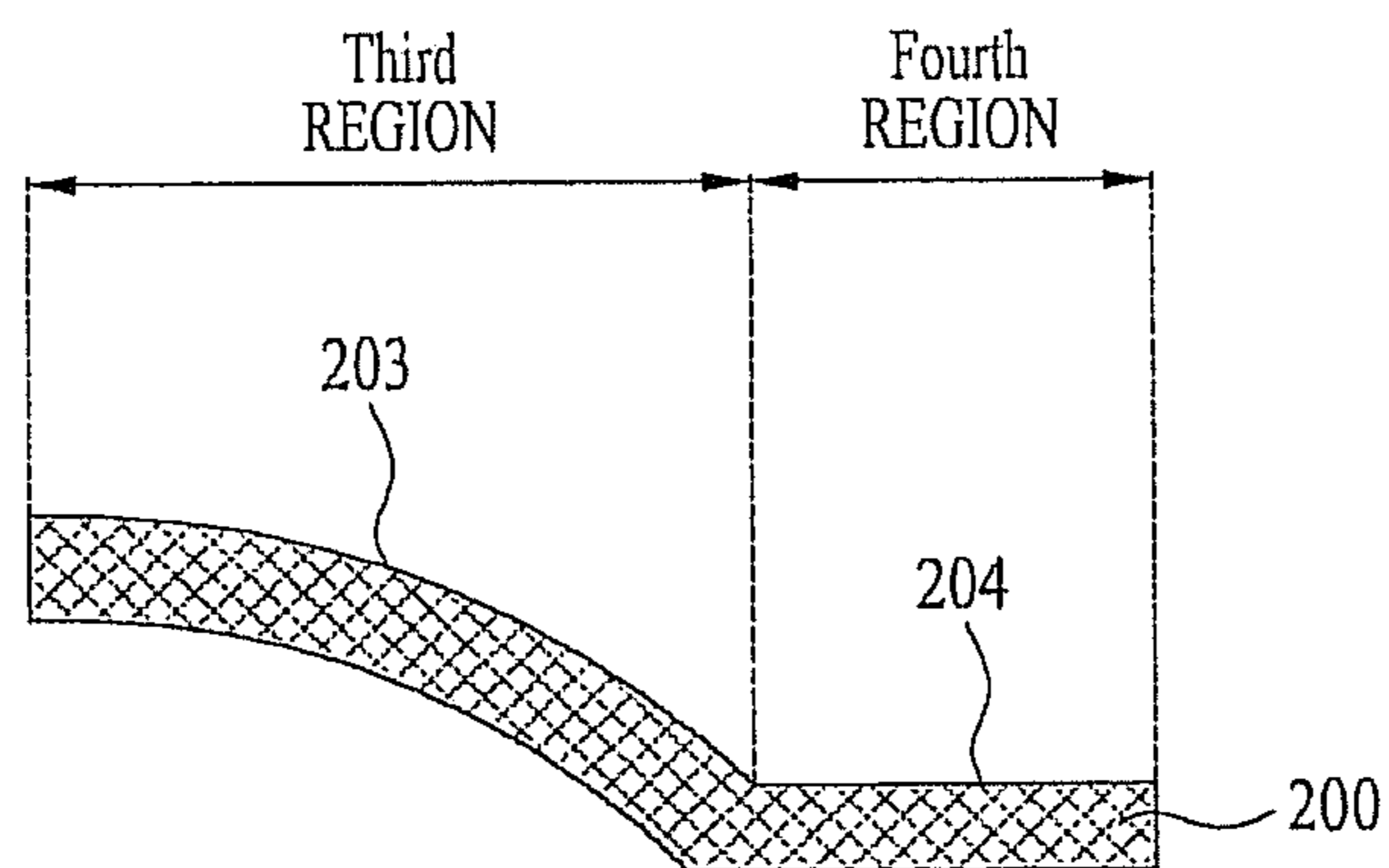

FIG. 8A

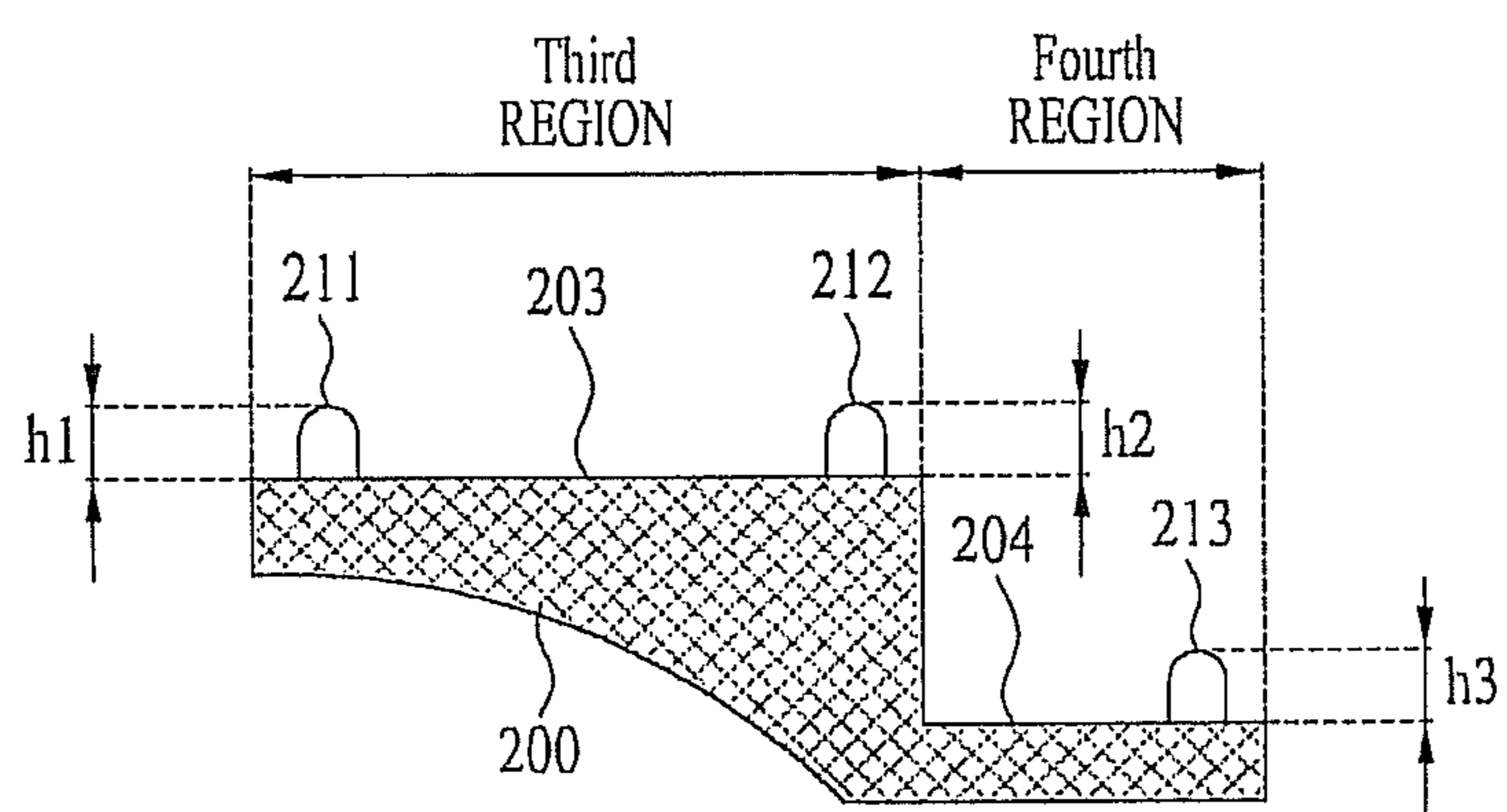

FIG. 8B

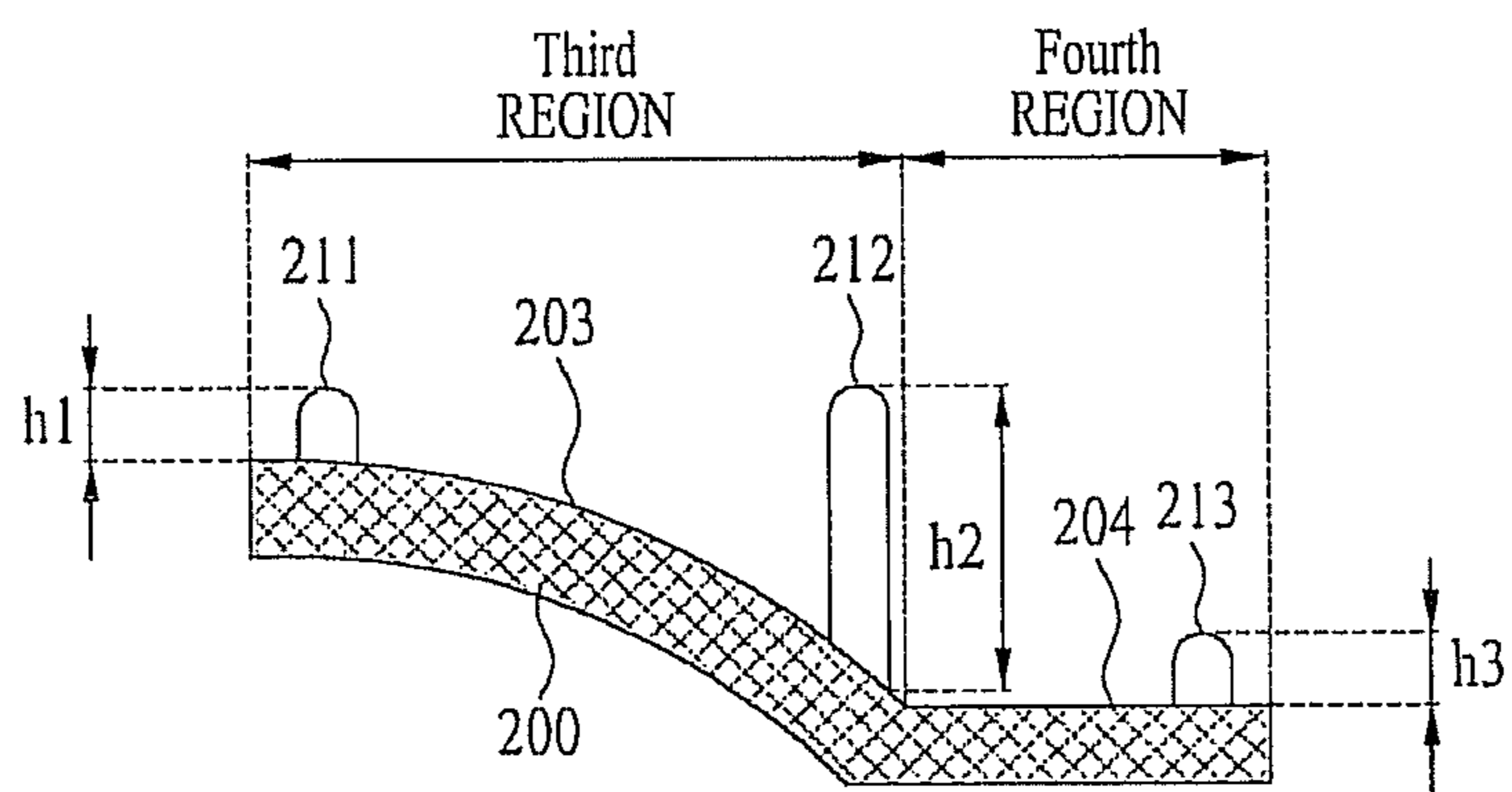

FIG. 9A

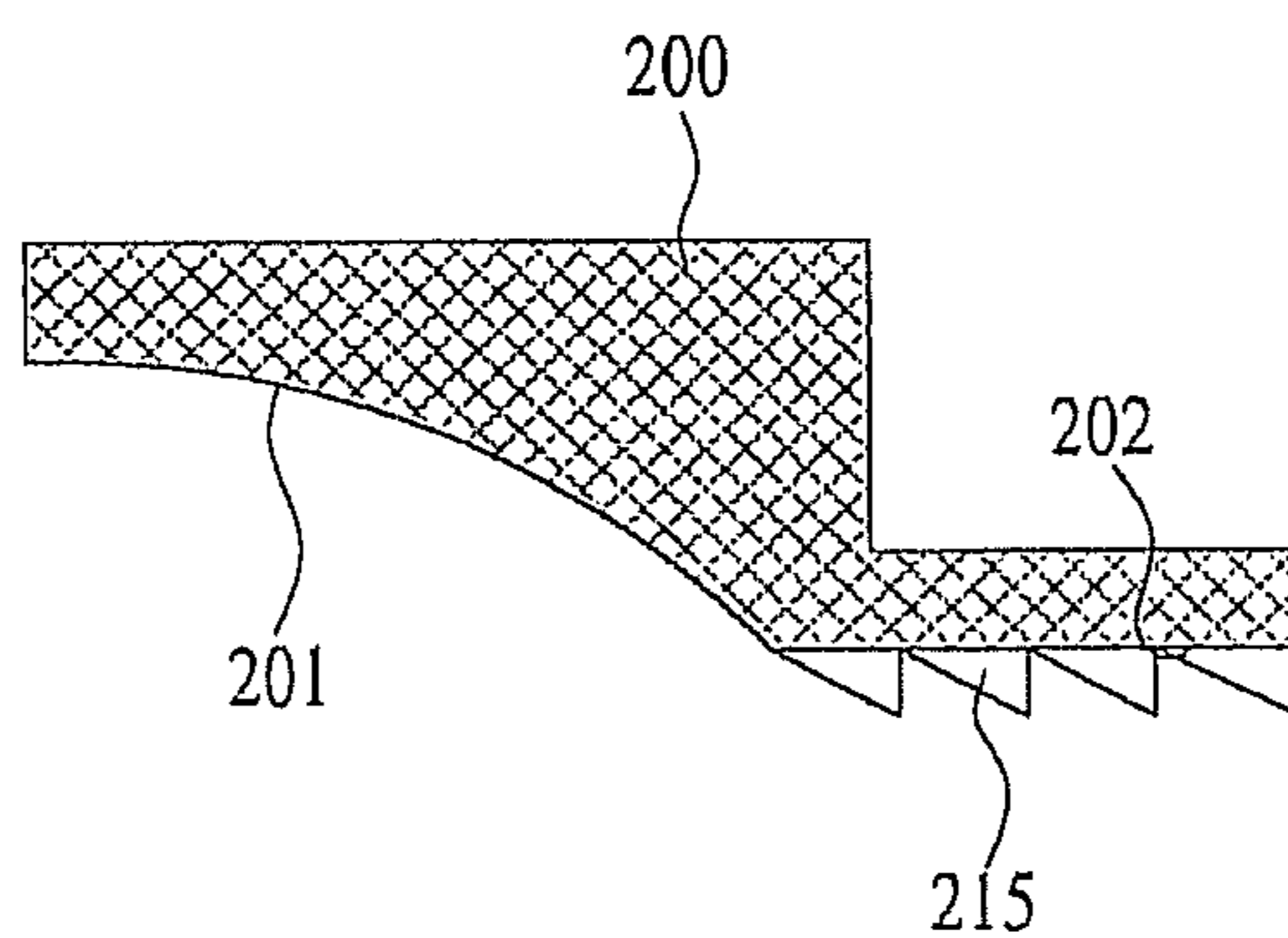

FIG. 9B

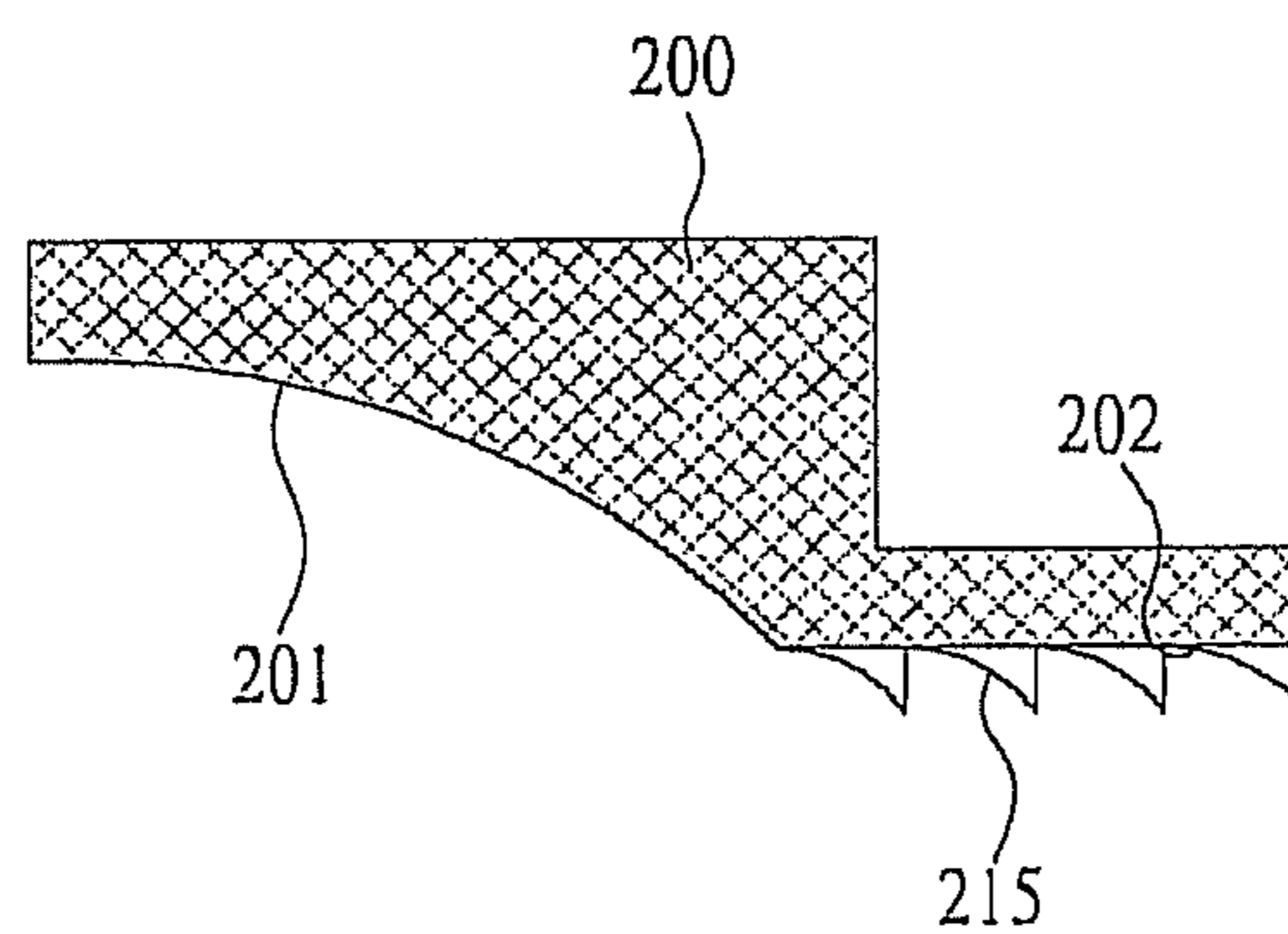

FIG. 9C

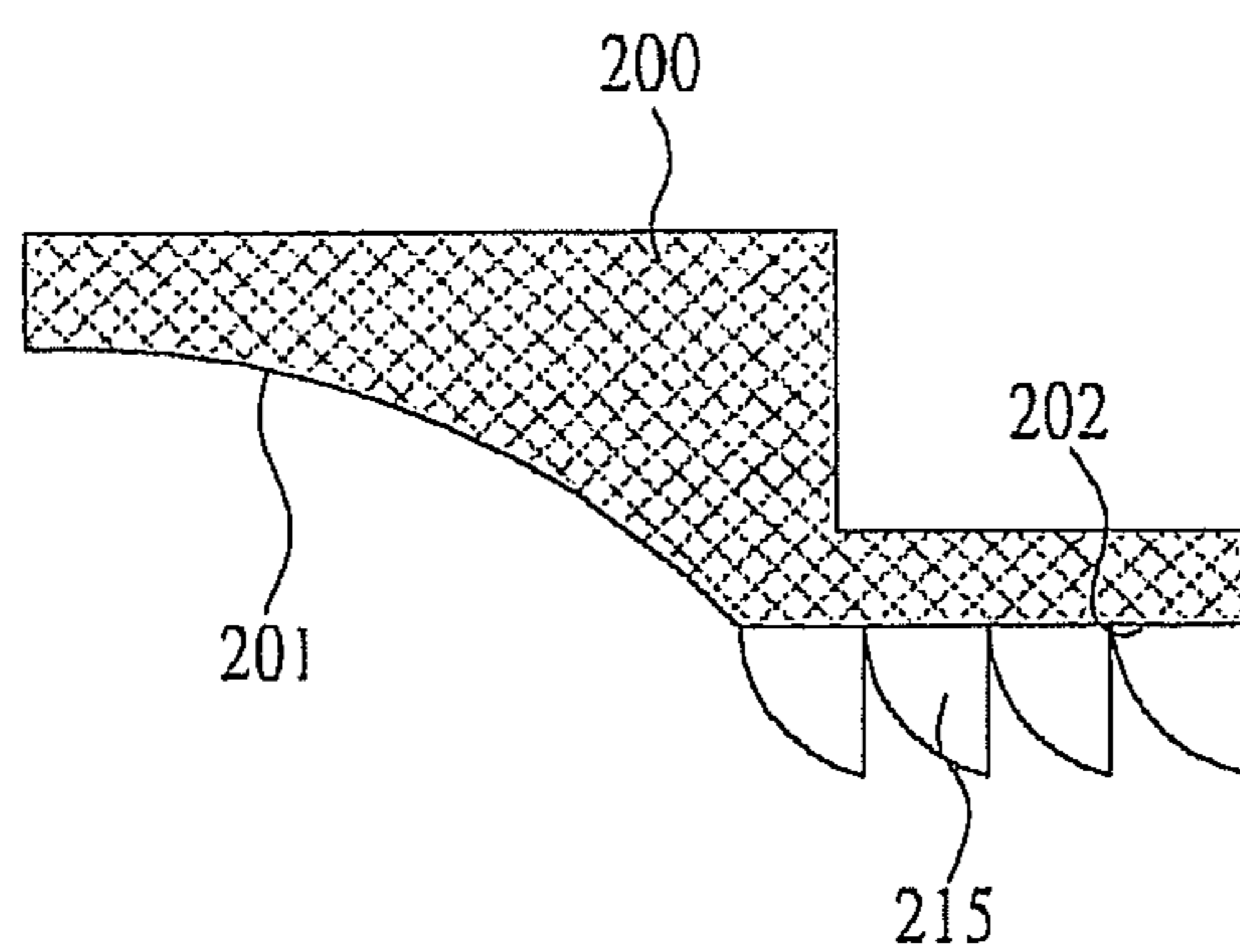

FIG. 9D

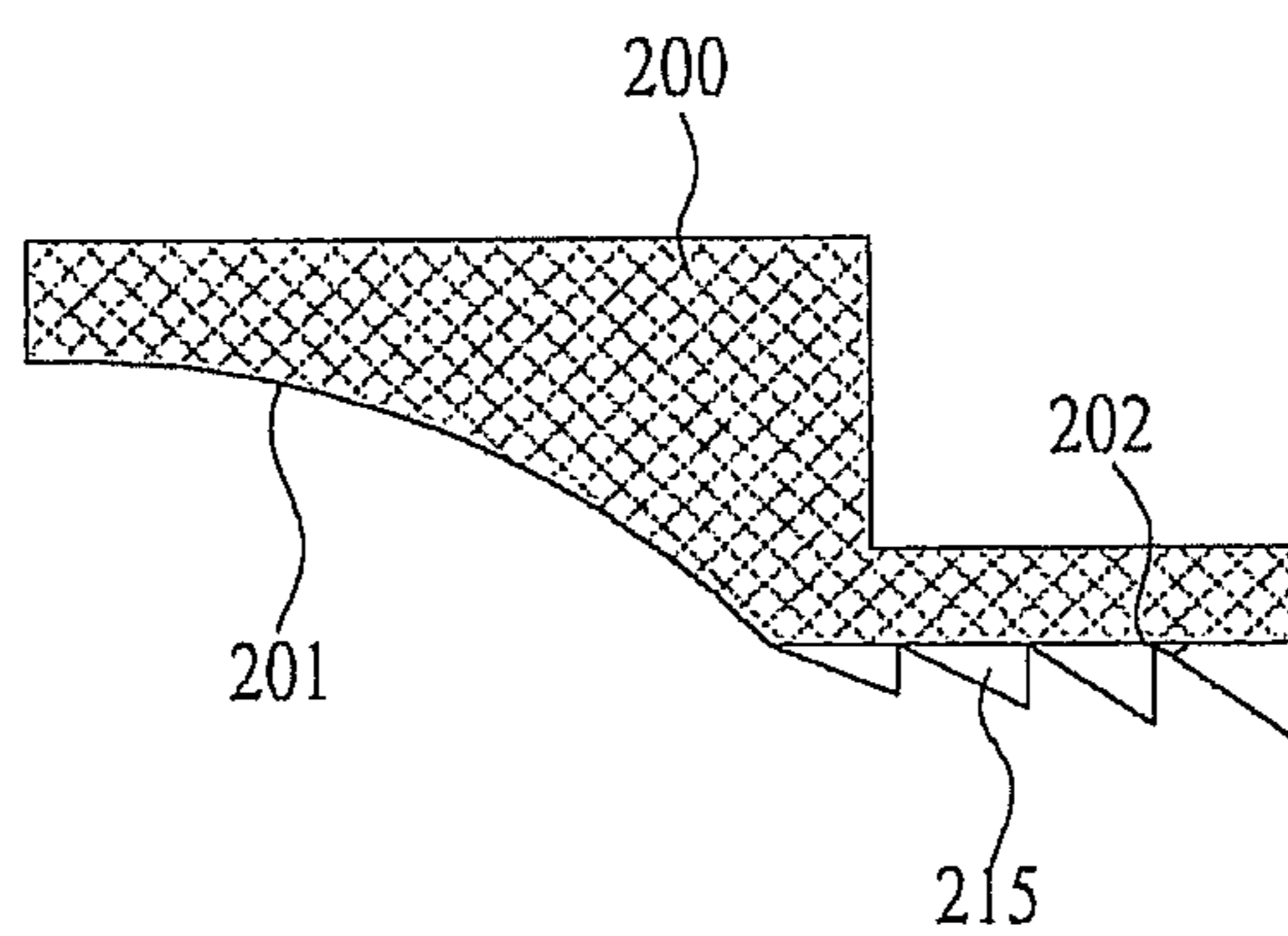

FIG. 10A

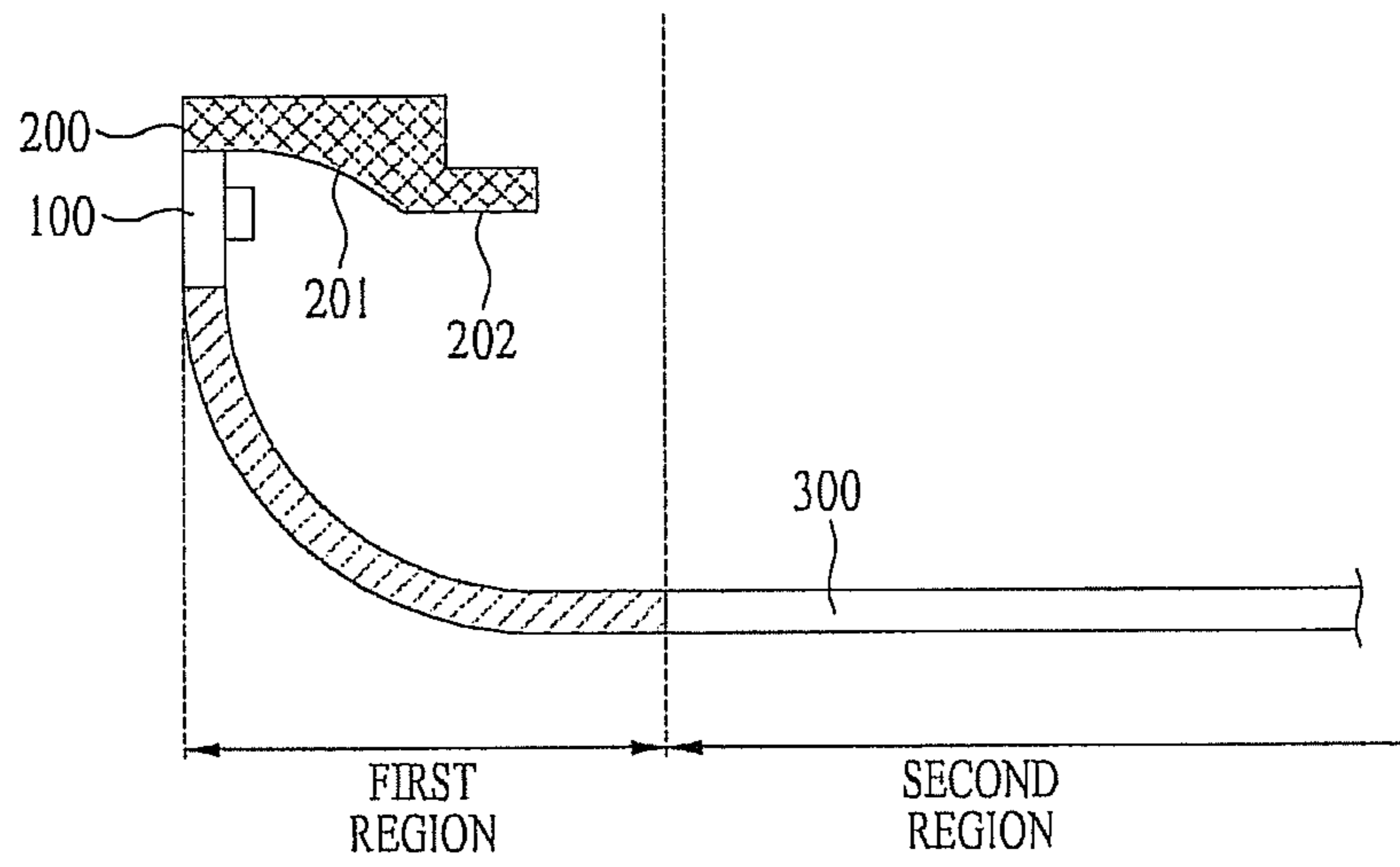

FIG. 10B

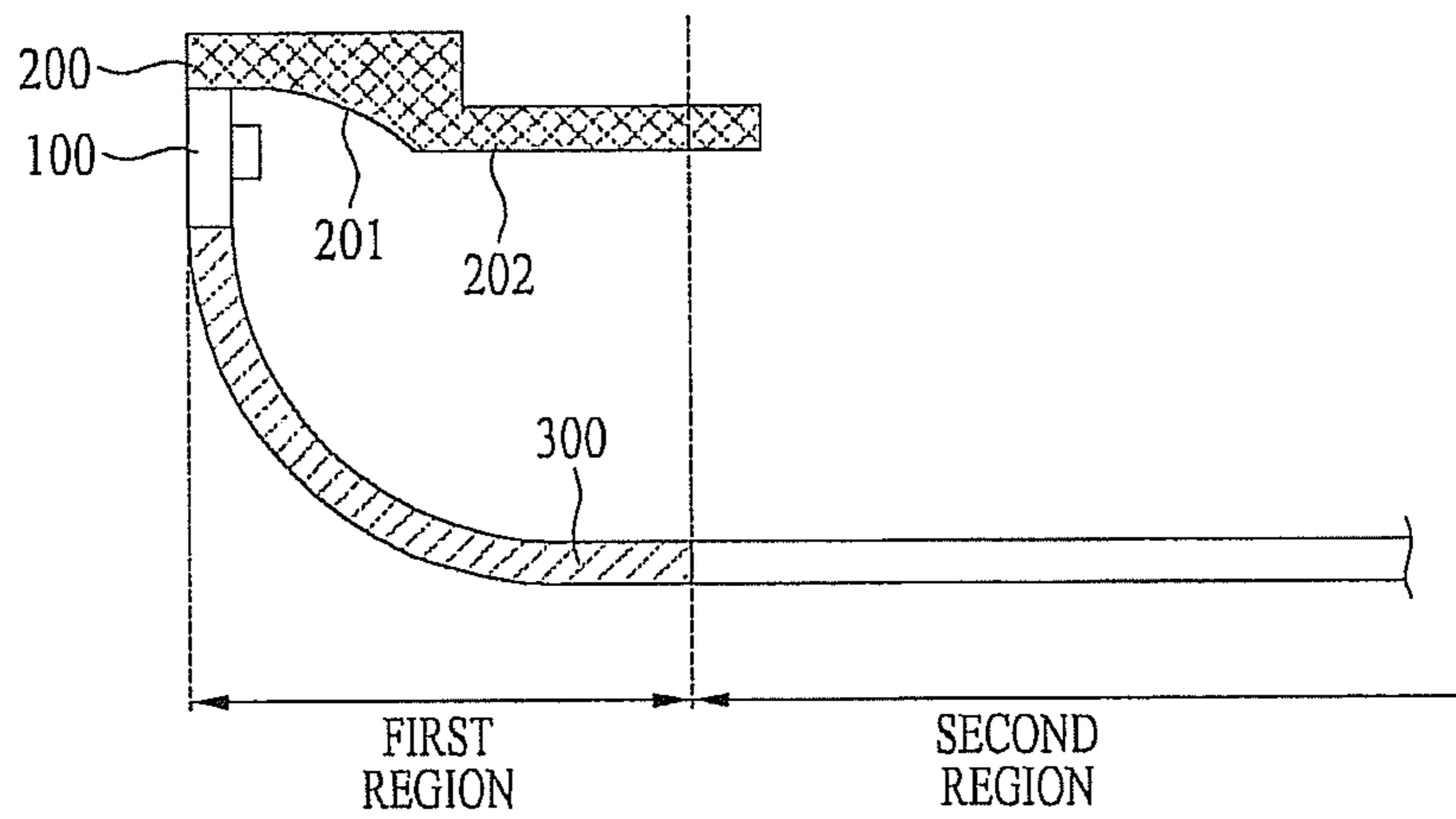

FIG. 10C

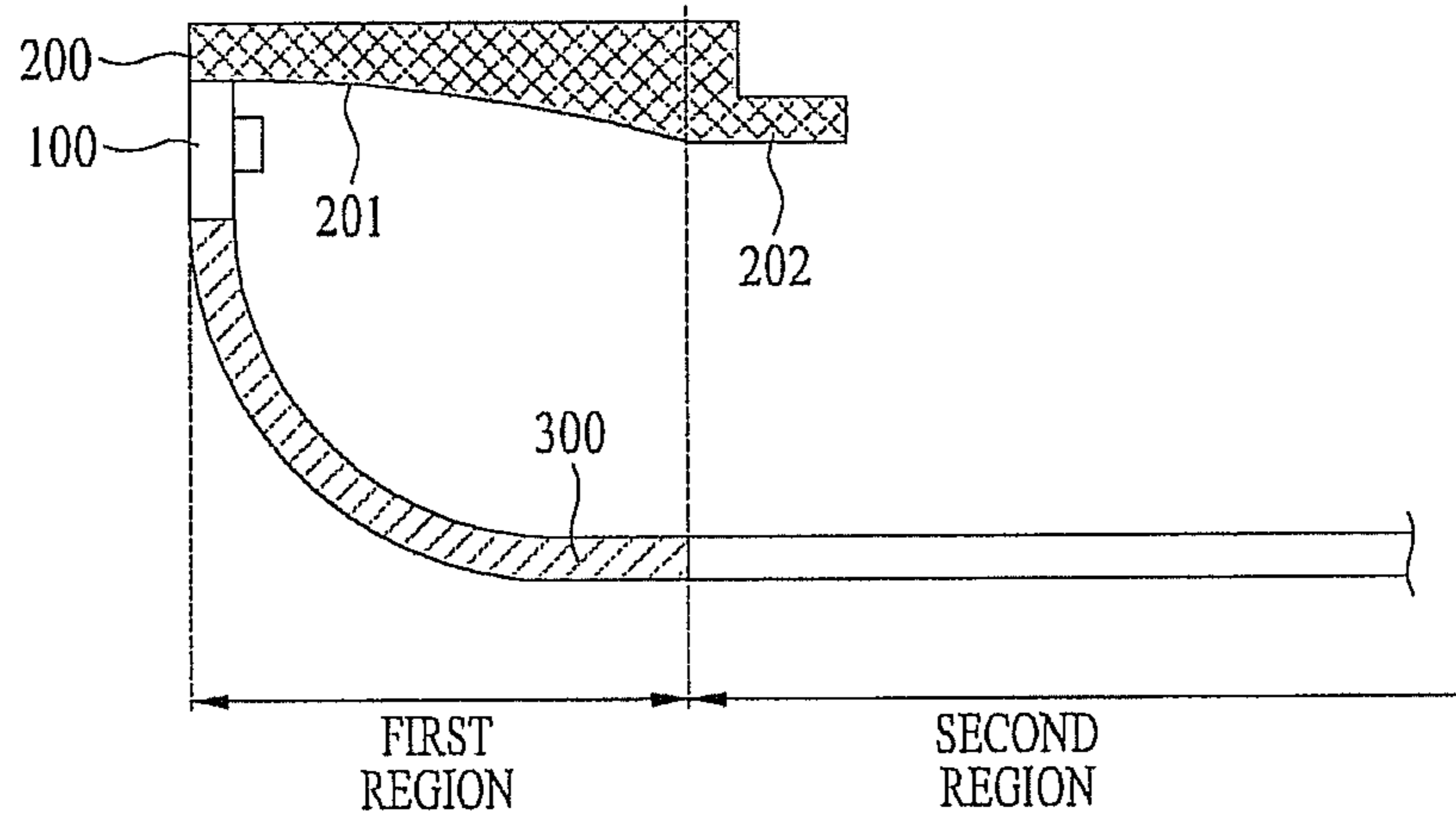

FIG. 11A

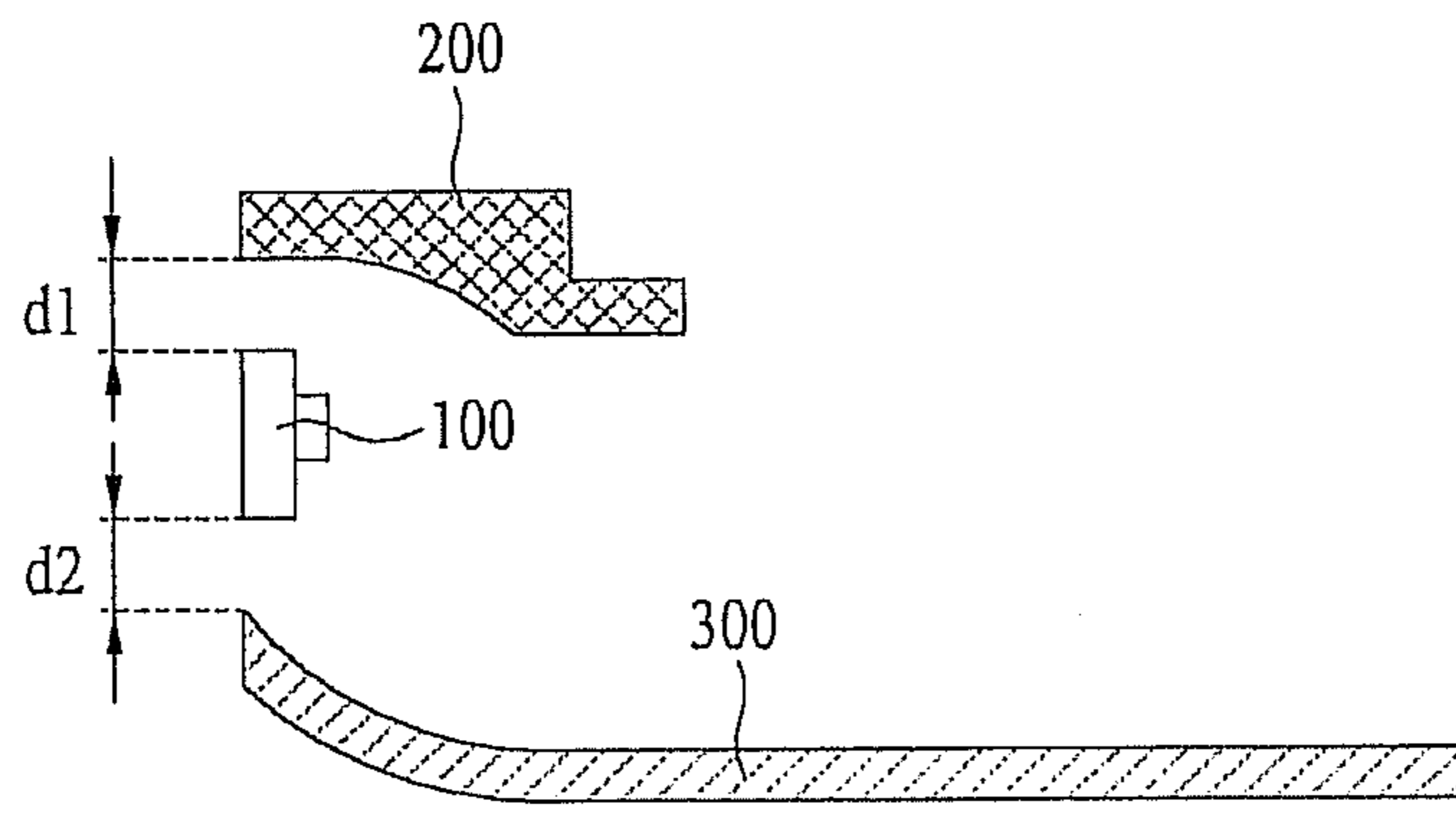

FIG. 11B

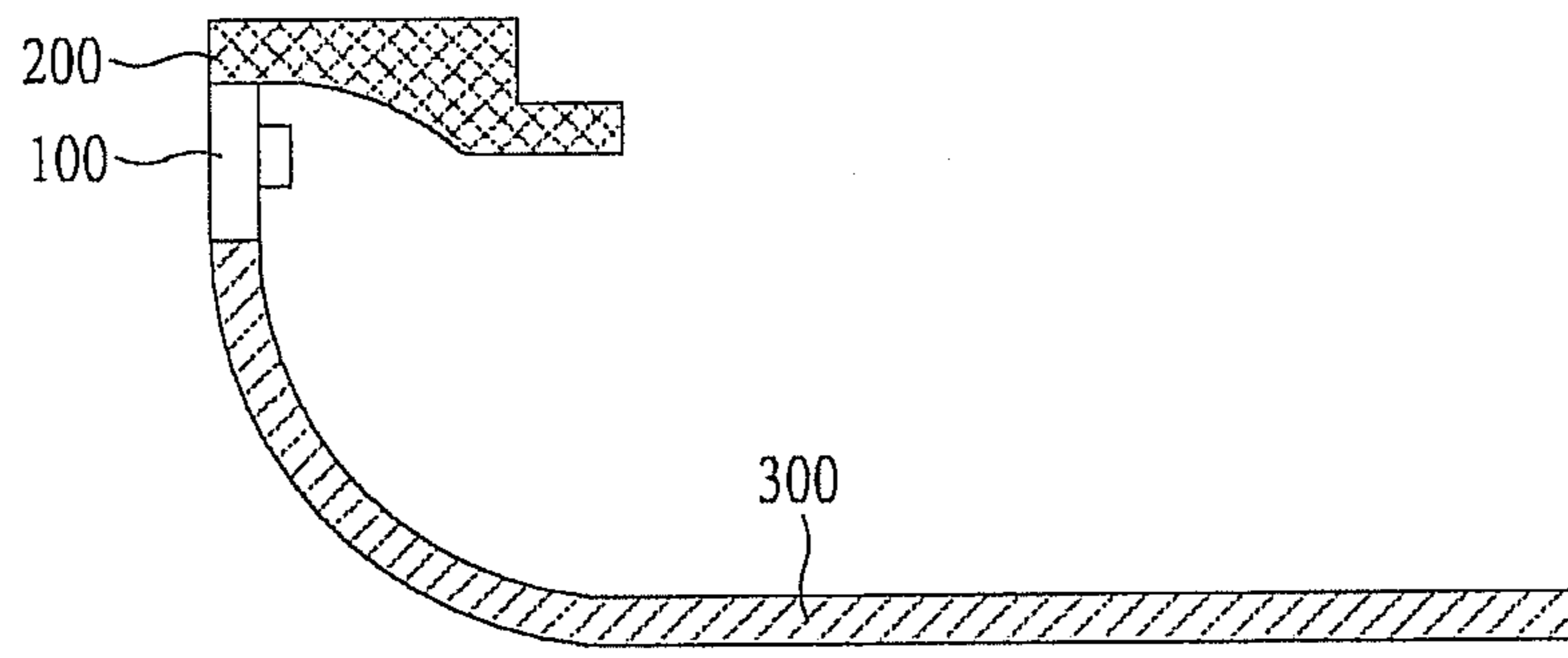

FIG. 11C

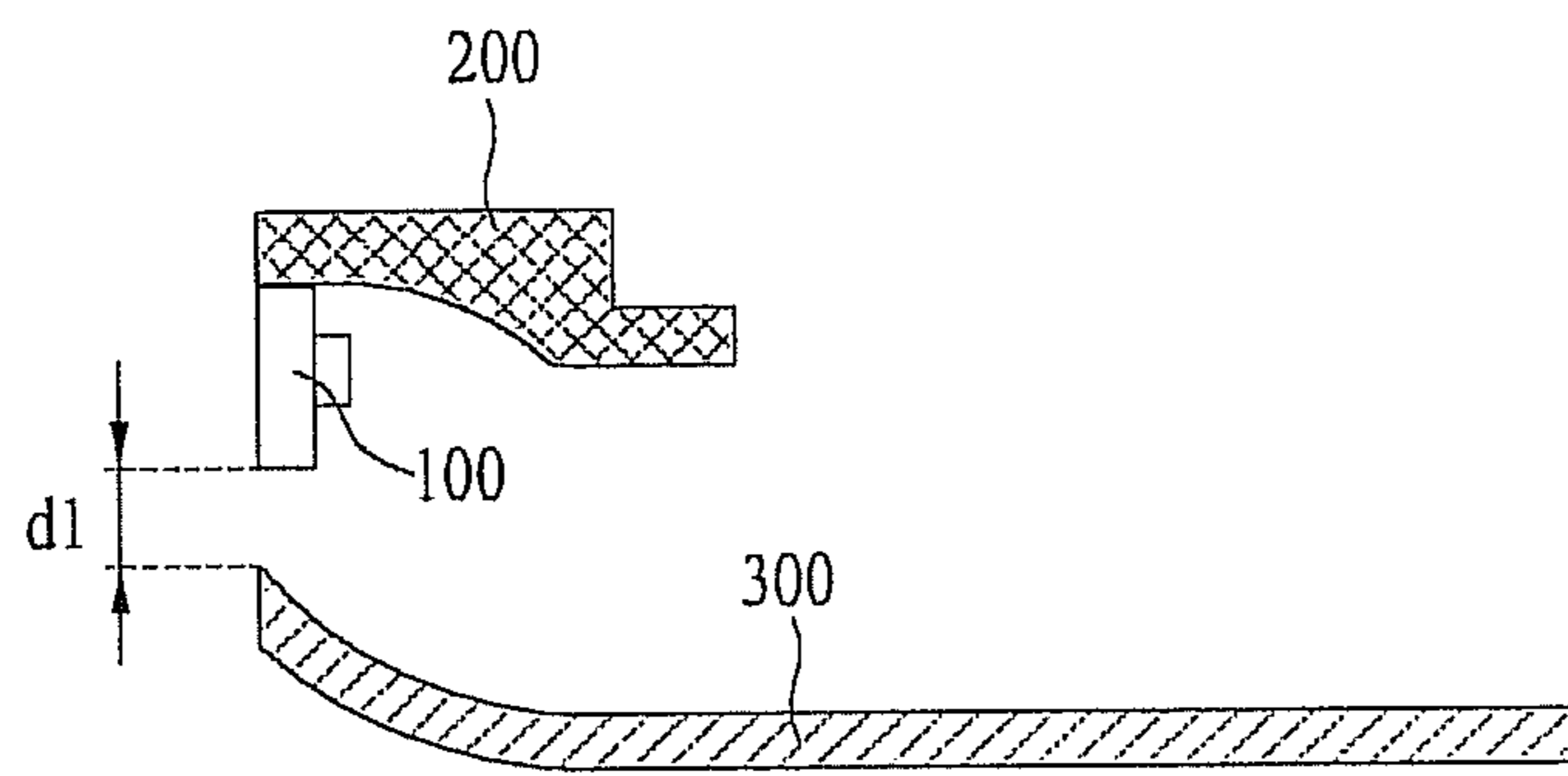

FIG. 11D

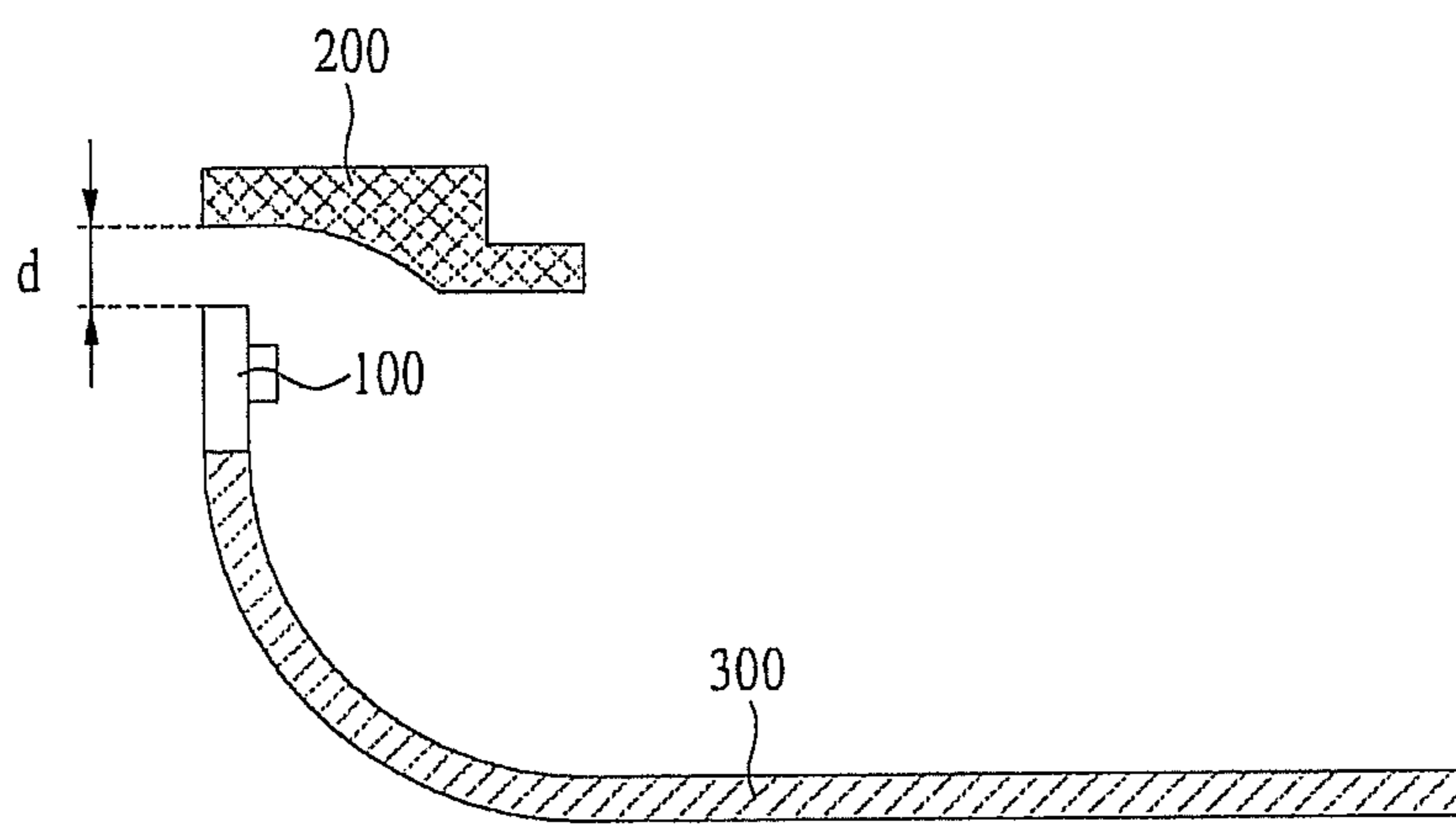

FIG. 12A

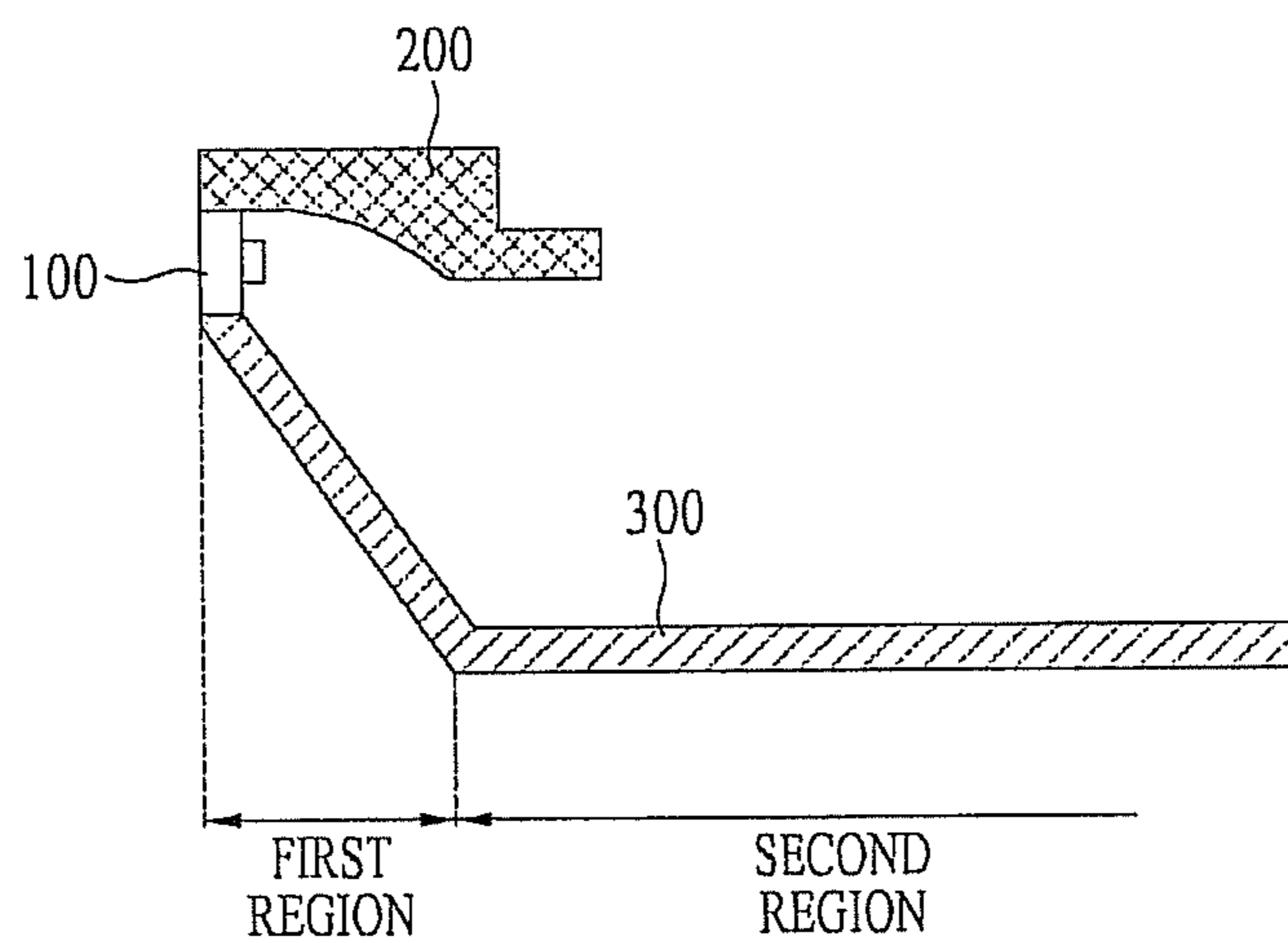

FIG. 12B

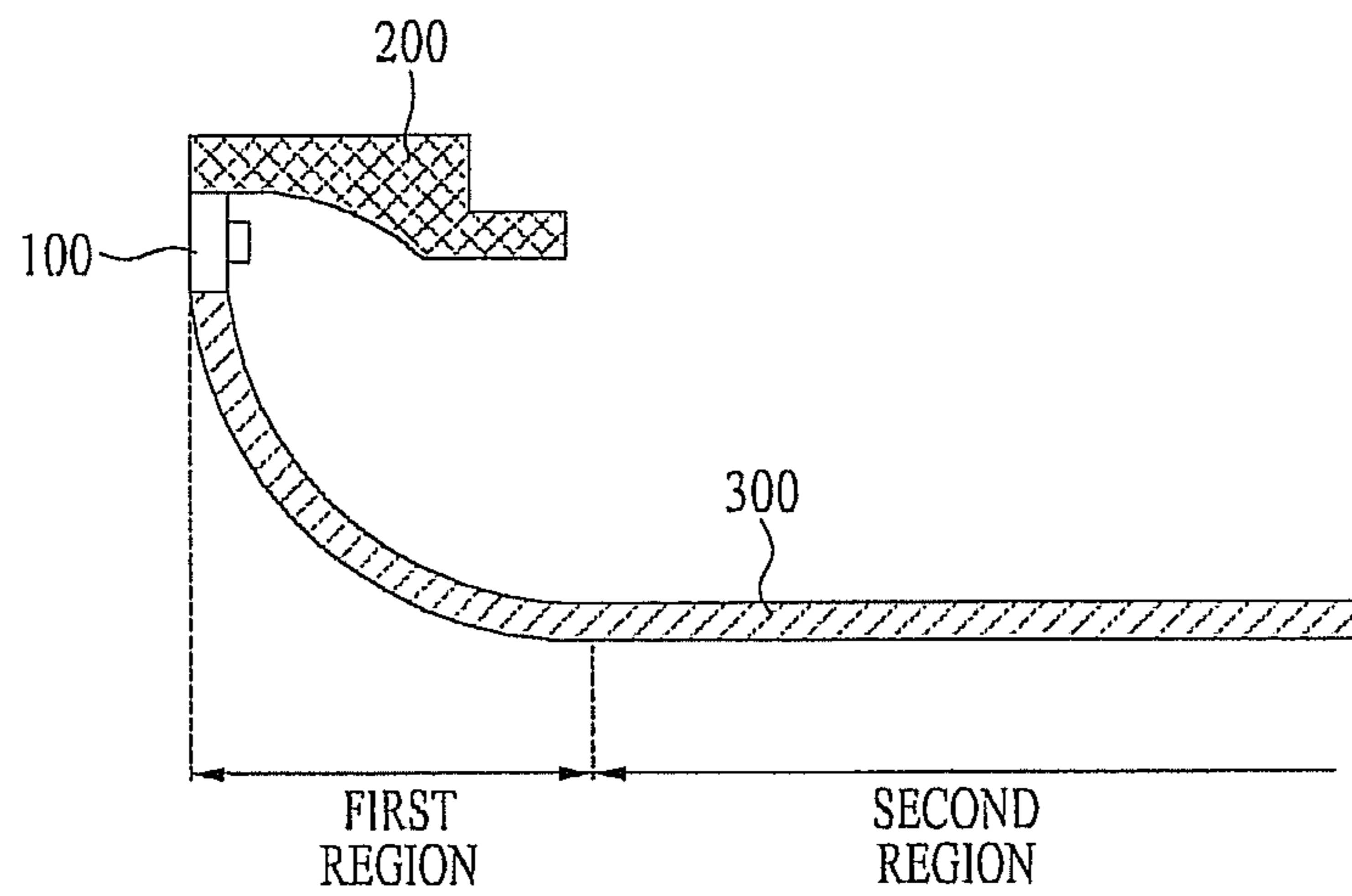

FIG. 12C

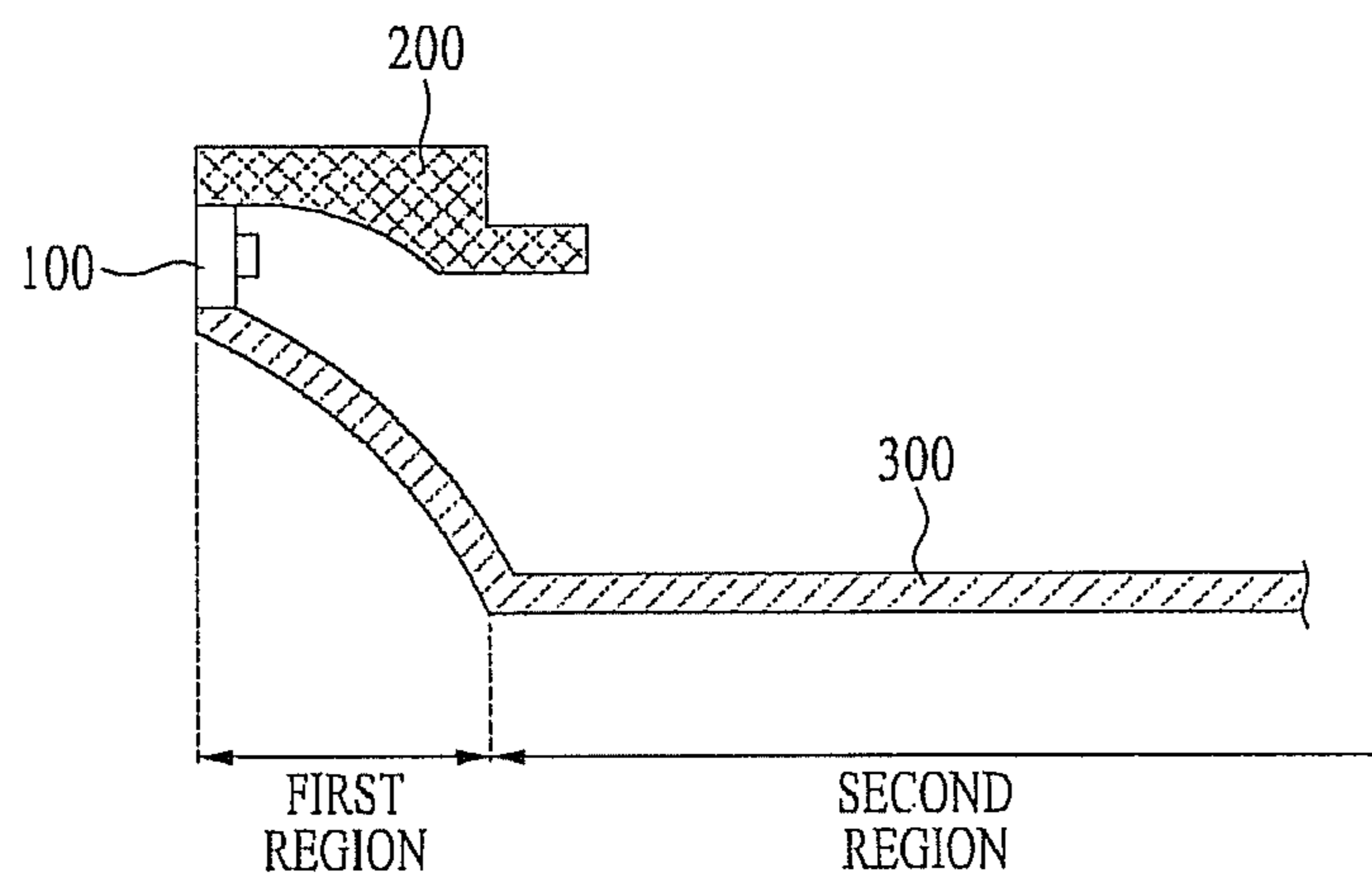

FIG. 13A

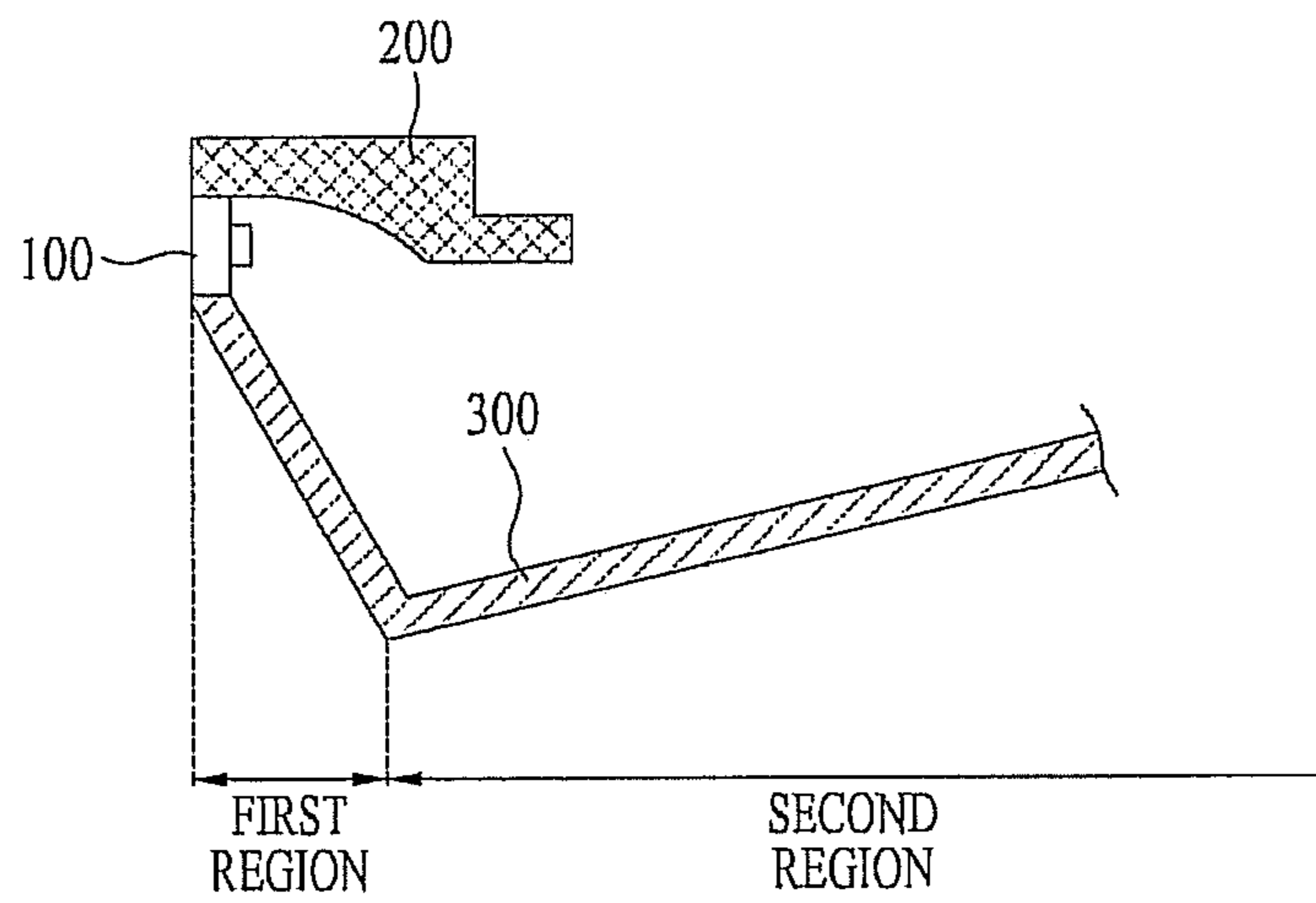

FIG. 13B

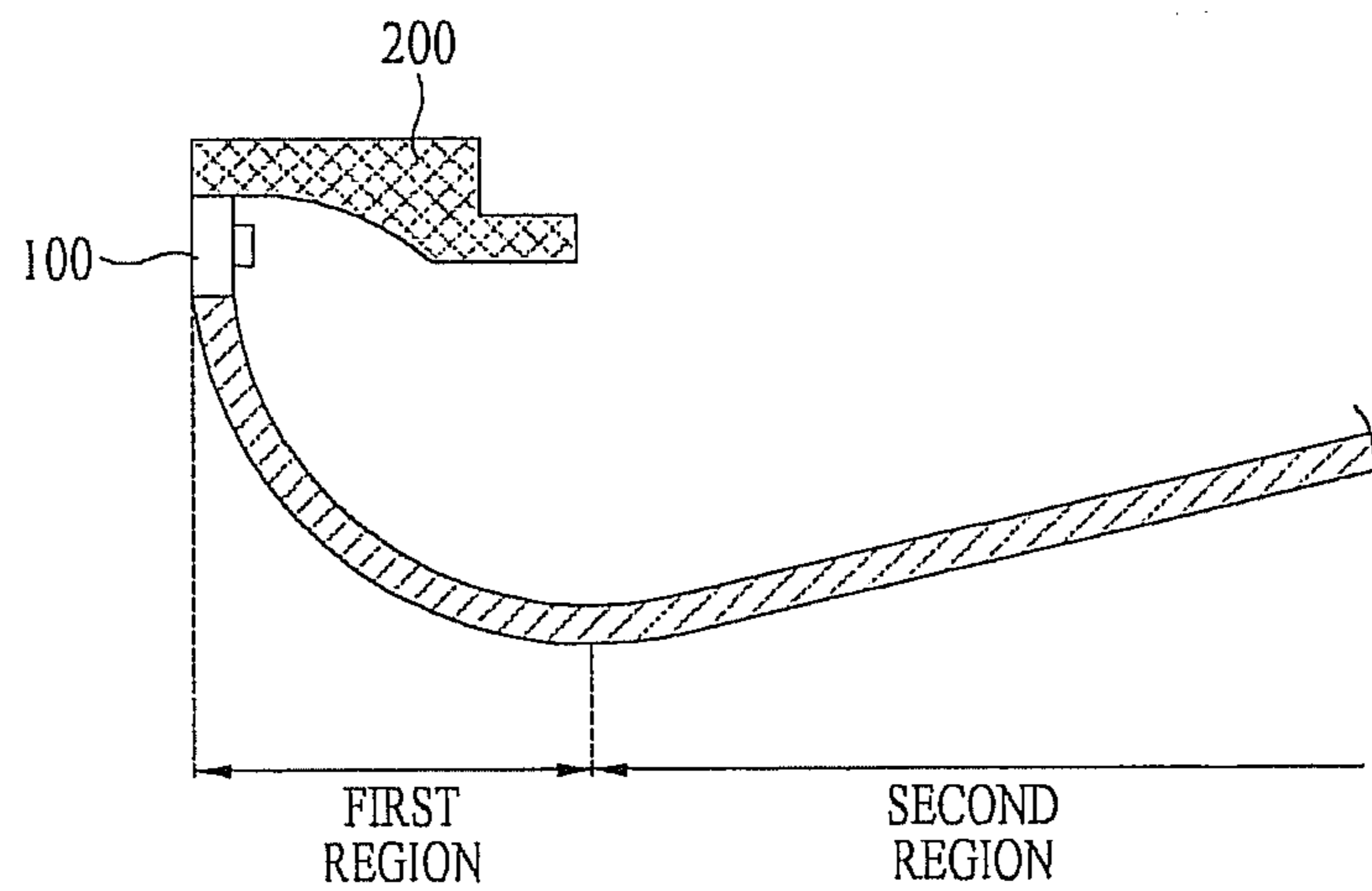

FIG. 13C

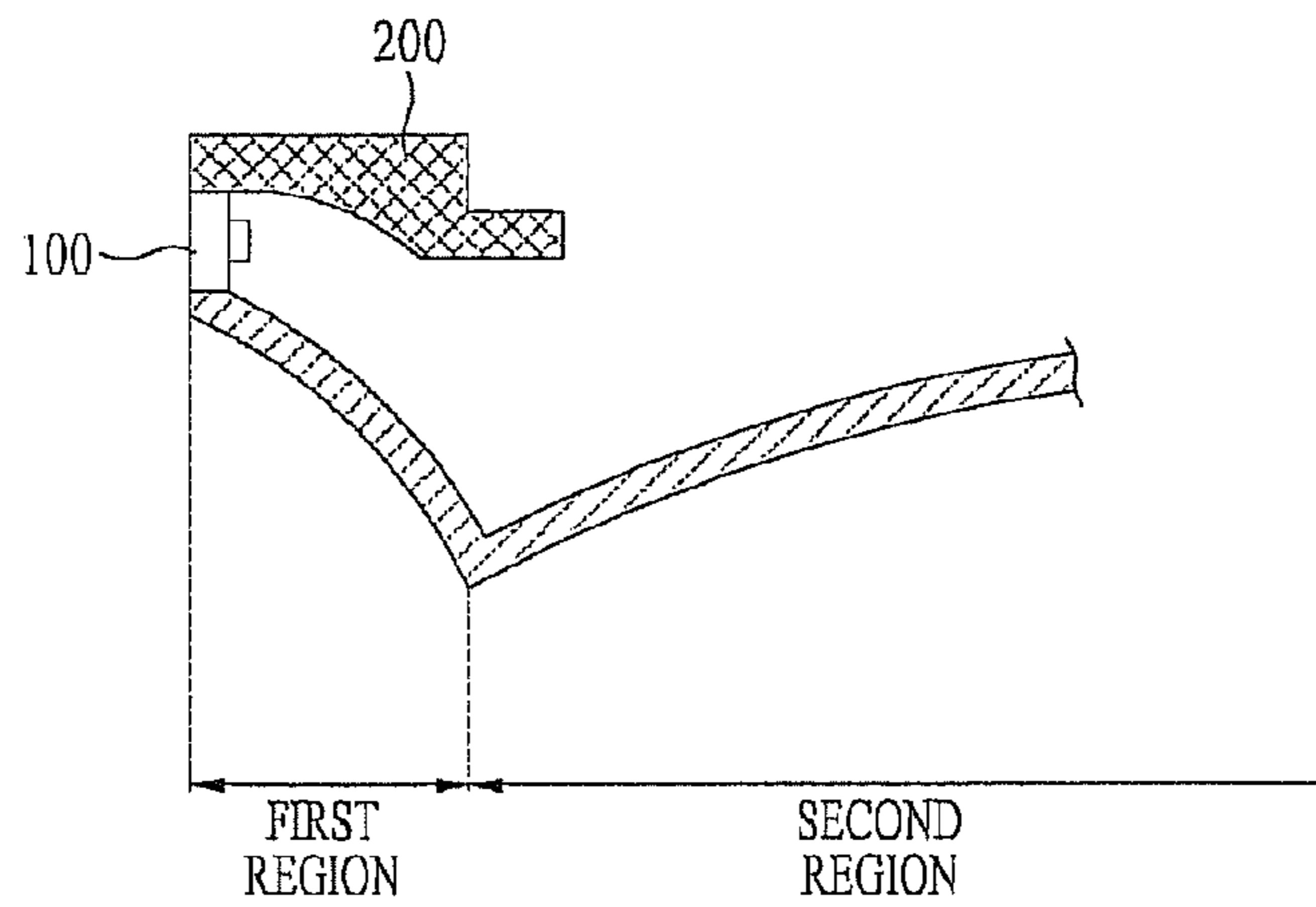

FIG. 14

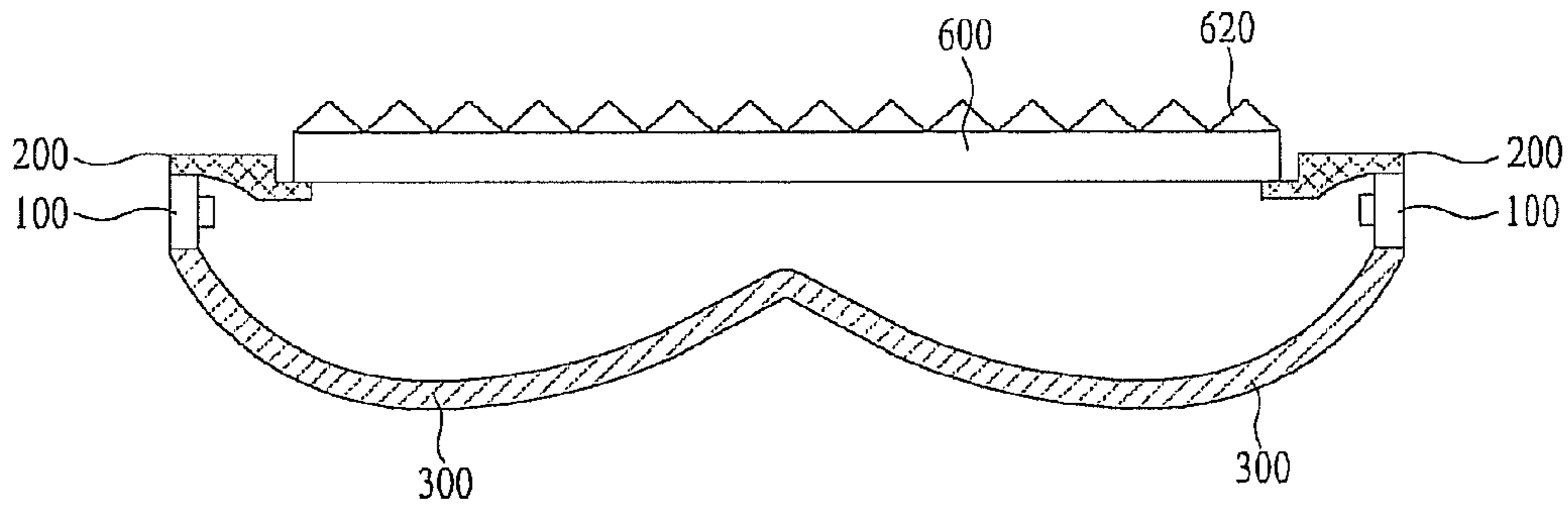

FIG. 15

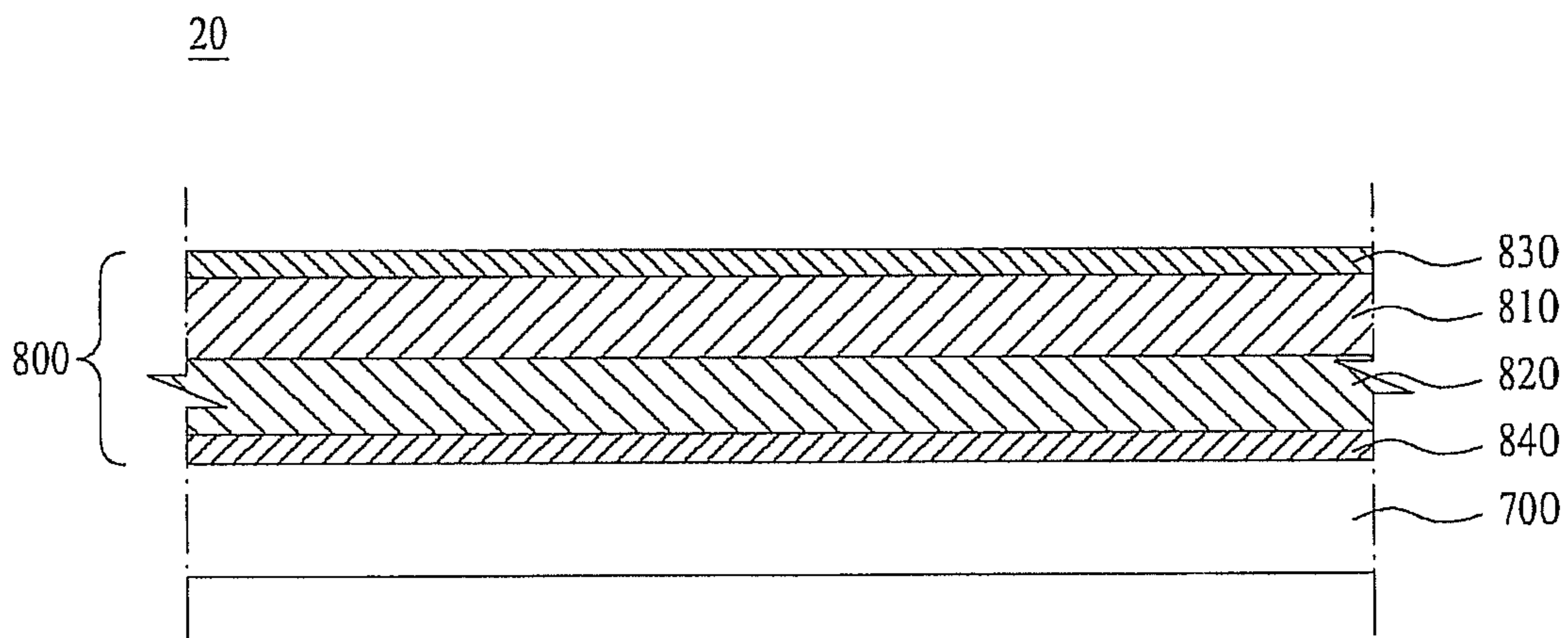

FIG. 16

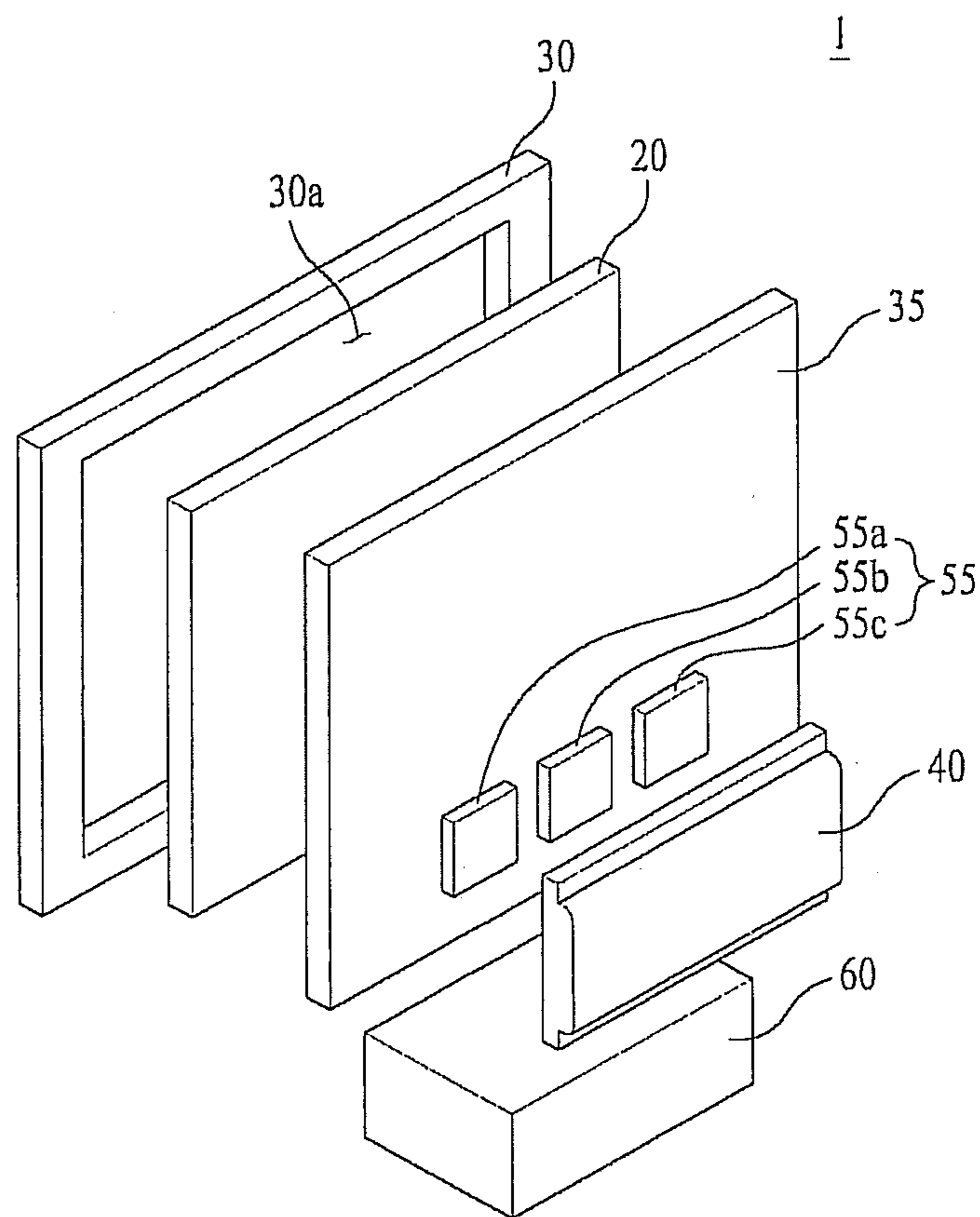
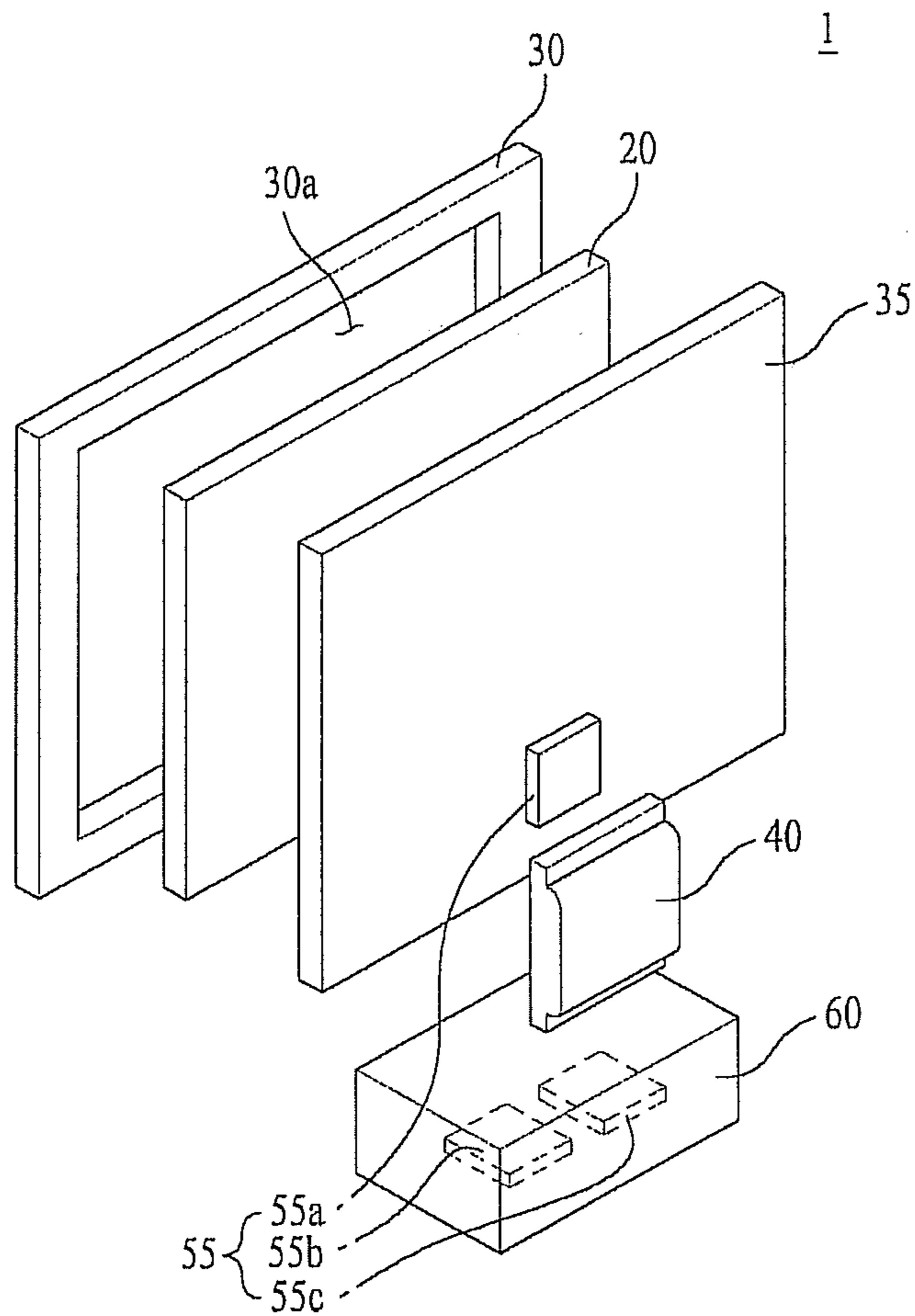

FIG. 17



1**BACKLIGHT UNIT AND DISPLAY DEVICE
USING THE SAME****CROSS-REFERENCE TO RELATED
APPLICATIONS**

This application is a Continuation Application of prior U.S. patent application Ser. No. 13/363,052 filed Jan. 31, 2012, which claims priority under 35 U.S.C. §119 to Korean Application No. 10-2011-0075995 filed on Jul. 29, 2011, whose entire disclosures are hereby incorporated by reference.

BACKGROUND**1. Field**

Embodiments may relate to a backlight unit and a display device.

2. Background

Generally, a conventional display device may include a liquid crystal display (LCD), a plasma display panel (PDP) and the like.

Different from the PDP that is self-luminescent, the LCD is not self-luminescent and it requires a backlight unit as a self-luminescent.

Such a backlight unit used in the LCD may be categorized into an edge backlight unit and a direct backlight, based on location of a light source. In the edge type, light sources are disposed on right and left lateral surfaces or up and down lateral surfaces of an LCD panel. Light may be dispersed to a front surface by a light guide plate uniformly. Because of that, the edge backlight unit has good uniformity of light and it may enable the panel ultra-thin.

The direct backlight unit is used for a 20-inch-or-more display. In the direct backlight unit, light sources are disposed on a backside of a panel. Because of that, the direct backlight unit has an advantage of better luminous efficiency than the edge backlight unit and it is used for a large display requiring high brightness.

A cold cathode fluorescent lamp (CCFL) is used for the light source of the conventional edge backlight unit or the direct backlight unit.

However, an electric voltage is applied to the backlight unit using the CCFL constantly and the amount of used electricity is increased. The CCFL has a disadvantage of approximately 70% of color reproduction, compared with a cold cathode fluorescent lamp (CCFL) and another disadvantage of environmental pollution because of mercury added thereto.

To solve such disadvantages, there have been actively in progress studies on a backlight unit using a light emitting diode (LED) substituting for the CCFL.

In case of using the LED for the backlight unit, a partial on/off of LED arrays may be enabled and power consumption may be reduced remarkably. A RGB LED exceeds 100% of color production specifications of National Television System Committee (NTSC) and a more vivid image quality may be provided to a consumer.

The above references are incorporated by reference herein where appropriate for appropriate teachings of additional or alternative details, features and/or technical background.

BRIEF DESCRIPTION OF THE DRAWINGS

The embodiments will be described in detail with reference to the following drawings in which like reference numerals refer to like elements wherein:

FIG. 1 is a sectional view illustrating a backlight unit according to an embodiment;

2

FIGS. 2A to 2C are sectional views illustrating a structure of a first reflector shown in FIG. 1;

FIG. 3 is a sectional view illustrating a location of a flat surface of the first reflector;

FIGS. 4A to 4C are sectional views illustrating the first reflector including a specular-reflection region;

FIGS. 5A and 5B are sectional views illustrating a boundary region between an inclined plane and a flat surface possessed by the first reflector;

FIGS. 6A and 6B are sectional views illustrating the thickness of the first reflector;

FIGS. 7A and 7B are sectional views illustrating the width of an upper surface possessed by the first reflector;

FIGS. 8A and 8B are sectional views illustrating a projection projected from the upper surface of the first reflector;

FIGS. 9A to 9D are sectional views illustrating a reflection pattern formed in the first reflector;

FIGS. 10A to 10C are sectional views illustrating the length of the first reflector;

FIGS. 11A to 11D are sectional views to explain an arrangement relation between a light source module and each of first and second reflectors;

FIGS. 12A to 12C are sectional views illustrating a second reflector including a slope side and a flat surface;

FIGS. 13A to 13C are sectional views illustrating a second reflector including a plurality of inclined planes;

FIG. 14 is a diagram illustrating a backlight unit having optical members disposed therein;

FIG. 15 is a diagram illustrating a display module including the backlight unit according to the embodiment; and

FIGS. 16 and 17 are diagrams illustrating a display device according to an embodiment.

DETAILED DESCRIPTION

Hereinafter, embodiments will be described with reference to the annexed drawings.

It will be understood that when an element is referred to as being 'on' or 'under' another element, it can be directly on/under the element, and one or more intervening elements may also be present.

When an element is referred to as being 'on' or 'under', 'under the element' as well as 'on the element' can be included based on the element.

FIG. 1 is a sectional view illustrating a backlight unit according to an embodiment.

As shown in FIG. 1, the backlight unit may include a light source module 100, a first reflector 200 and a second reflector 300.

Here, the light source module 100 may be located between the first reflector 200 and the third reflector 300. Here, the light source module 100 may be adjacent to the first reflector 200.

In some cases, the light source module 100 may be spaced apart a predetermined distance from the second reflector 300, simultaneously in contact with the first reflector 200. Alternatively, the light source module 100 may be spaced apart a predetermined distance from the first reflector 200, simultaneously in contact with the second reflector 200.

Alternatively, the light module 100 may be spaced apart a predetermined distance from the first reflector 200 and the second reflector 300 or it may be in contact with the first reflector 200 and the second reflector 300.

The light source module 100 may include a substrate having an electrode pattern and at least one light source disposed on the substrate.

Here, the light source of the light source module **100** may be a top view type light emitting diode.

Alternatively, the light source may be a side view type light emitting diode.

The substrate may be a printed circuit board (PCB) formed of a selected material from polyethylene terephthalate (PET), glass, polycarbonate (PC) and silicon (Si), or the substrate may be a film.

Alternatively, the substrate may be a unilayered PCB, a multilayered PCB, a ceramic substrate or a metal core PCB selectively.

Here, a reflection coating film or a reflection coating material layer may be formed on the substrate and the substrate may reflect the light generated from the light source toward a central region of the second reflector **300**.

The light source may be a light emitting diode (LED) chip and the light emitting diode chip may be configured of a blue LED chip, an ultraviolet light LED chip or it may be configured of a package combined with one or more of red, green, blue, yellow green and white LED chips.

The white LED may be realized by combining a yellow phosphor on the blue LED or combining a red phosphor and a green phosphor on the blue LED, or by using a yellow phosphor, a red phosphor and a green phosphor on the blue LED simultaneously.

Next, the first reflector **200** and the second reflector **300** may be facing each other, spaced apart a predetermined distance, to have air guide between them.

The first reflector **200** may be formed of a reflection coating film or a reflection coating material and it may reflect the light generated from the light source module **100** toward the second reflector **300**.

Here, a back surface of the first reflector **200** may face the second reflector **300**, with an inclined plane and a flat surface.

At this time, the inclined plane may be adjacent to the light source module **100** and the flat surface may be extended from an end of the inclined plane, with being located at the collinear position with respect to the light source module **100**.

The inclined plane of the first reflector **200** may be inclined a predetermined angle downwardly from a top surface of the first reflector **200**. The flat surface of the first reflector **200** may be in parallel to the top surface of the first reflector **200**.

Here, the inclined plane of the first reflector may be a concave surface, a convex surface or a flat surface.

The reason why the predetermined area of the back surface disposed in the first reflector **200** may be the inclined plane is that a hot spot of a light-entry region, the size of the first reflector **200** can be reduced by the first reflector **200** reflecting the light toward the second reflector **300**. Because of that, a bezel region may be reduced advantageously.

The inclined plane may be disposed in a predetermined region of the first reflector **200** and the first reflector **200** may include a metal material or a metal oxide, with a high reflectivity, such as aluminum (Al), silver (Ag), gold (Au) and titanium dioxide (TiO₂).

A saw-toothed reflection pattern may be formed in a predetermined region of the back side of the first reflector **200**.

Here, the reflection pattern may be a flat surface or a curved surface.

The reason why the reflection pattern is formed in the predetermined region of the first reflector **200** is that brightness may be increased in a central region of the backlight unit by reflecting the light generated from the light source module **100** toward the central region of the second reflector **300**.

An inclined plane may be formed in a predetermined region of the second reflector **300** and the second reflector **300**

may include a metal material or a metal oxide, with a high reflectivity, such as Al, Ag, Au and TiO₂.

The inclined plane may be aligned with at least one of the light source module **100** and the first reflector **200**.

Here, the inclined plane of the second reflector **300** may be inclined a predetermined angle with respect to the surface of the first reflector **200** and it may be at least one of concave, convex and flat surfaces.

In some cases, the second reflector **300** may include at least one inclined plane and at least one flat surface. The flat surface of the second reflector **300** may be in parallel to the flat surface of the first reflector **200**.

Furthermore, the second reflector **300** may include at least two inclined planes with at least one inflection point. The curvatures of first and second inclined planes adjacent to each other with respect to the inflection point may be different from each other.

FIGS. 2A to 2C are sectional views illustrating the structure of the first reflector shown in FIG. 2.

As shown in FIGS. 2A to 2C, the back surface of the first reflector **200** may include a first region adjacent to the light source module **100** and a second region adjacent to the first region.

Here, the first region may be an inclined plane **201** and the second region may be a flat surface **202**.

The inclined plane **201** of the first region may be inclined a predetermined angle along downward direction of the first reflector **200** and the flat surface **202** of the second region may be in parallel to the top surface of the first reflector **200**.

At this time, the flat surface **202** of the second region may be extended from an end of the inclined plane **201**, and the flat surface **202** and the light source module **100** may be collinear.

In case of FIG. 2A, the inclined plane **201** of the first reflector **200** may be a concave surface with a predetermined curvature.

In case of FIG. 2B, the inclined plane **201** of the first reflector **200** may be a convex surface with a predetermined curvature. In case of FIG. 2C, the inclined plane **201** of the first reflector **200** may be a flat surface with a predetermined inclined angle.

FIG. 3 is a sectional view illustrating arrangement of the flat surface disposed in the first reflector.

As shown in FIG. 3, the light source module **100** may include a substrate **102** and at least one light source **101** disposed on the substrate **102**.

Here, the light source **101** may have a top surface with a first width (W1) and the flat surface **202** of the first reflector **200** may be disposed in a center of the first width (W1) of the light source **101**.

If the flat surface **202** of the first reflector **200** is disposed beyond the center (in an upper area) of the width (W1) of the light source **101**, a hot spot may be generated in the light-entry region.

If the flat surface **202** of the first reflector **200** is disposed under the center of the first width (W1) (in a lower area of the width) of the light source **101**, the light might be blocked or brightness might be degraded entirely.

As a result, if the flat surface **202** of the first reflector **200** is disposed within the first width (W1), the hot spot may be reduced in the light-entry region and the size of the first reflector **200** may be reduced. Because of that, the bezel region of the display panel may be reduced advantageously.

In addition, the inclined plane **201** of the first reflector **200** may have a second width (W2) and the flat surface **202** of the first reflector may have a third width (W3).

5

Here, the second width (W2) of the inclined plane **201** may be identical to or different from the third width (W3) of the flat surface **202**.

For example, the second width (W2) of the inclined plane **201** may be larger than the third width (W3) of the flat surface **202**.

FIGS. **4A** to **4C** are sectional views illustrating the first reflector that includes a specular-reflection region.

As shown in FIGS. **4A** to **4C**, the back surface of the first reflector **200** may include a specular-reflection region to specular-reflect the light or a scattered-reflection region to scattered-reflect the light.

In case of FIG. **4A**, the back surface of the first reflector **200** may include an inclined plane **201** and a flat surface **202**. Both of the inclined plane **201** and the flat surface **202** may be the specular-reflection regions.

In other words, a specular-reflection sheet may be disposed on the inclined plane **201** and the flat surface **202**, to specular-reflect the light.

In case of FIG. **4B**, the back surface of the first reflector **200** may include an inclined plane **201** and a flat surface **202**. The inclined plane **201** may be the specular-reflection region and the flat surface **202** may be the scattered-region.

In other words, a specular-reflection sheet may be disposed on the inclined plane **201** to specular-reflect the light and a scattered-reflection sheet may be disposed on the flat surface **202** to scattered-reflect the light.

In case of FIG. **4C**, the back surface of the first reflector **200** may include an inclined plane **201** and a flat surface **202**. The inclined plane **201** may be a specular-reflection region and the flat surface **202** may include a specular-reflection region and a scattered-reflection region.

In other words, a specular-reflection sheet may be disposed on the inclined plane **201** to specular-reflect the light. The specular-reflection sheet may be disposed on a predetermined region of the flat surface **202** and a scattered-reflection sheet may be disposed on the other region to scattered-reflect the light.

Here, the full-reflection sheet disposed on the flat surface **202** may be adjacent to the inclined plane **201** or between specular-reflection sheets.

If the specular-reflection sheet is disposed on the first reflector **200**, more lights may be reflected to the second reflector **300**. If the scattered-reflection sheet is disposed on the first reflector, the light may be transmitted to a region of the second reflector **300** having low brightness and the low brightness may be compensated.

FIGS. **5A** and **5B** are sectional views illustrating a boundary region between the inclined plane and the flat surface of the first reflector.

As shown in FIG. **5A**, the first reflector **200** may include an inclined plane **201** and a flat surface **202** formed on the back surface thereof. A boundary region between the inclined plane **201** and the flat surface **202** may have a dihedral angle formed by them.

However, as shown in FIG. **5B**, the boundary region between the inclined plane **201** and the flat surface **202** may include a convex surface with a predetermined curvature.

The reason why the boundary region between the inclined plane **201** and the flat surface **202** is the convex surface with the curvature is following. If the dihedral angle is formed in the boundary region between the inclined plane **201** and the flat surface **202**, the incident light might be concentrated only on some region and overall brightness might fail to be uniform.

6

Because of that, the boundary region between the inclined plane **201** and the flat surface **202** may be formed to be a convex surface with a predetermined curvature and uniform brightness may be provided.

FIGS. **6A** and **6B** are sectional views illustrating the thickness of the first reflector.

First of all, as shown in FIG. **6A**, the first reflector **200** may include a first region adjacent to the light source module and a second region adjacent to the first region.

Here, a back surface of the first region disposed in the first reflector **200** may have an inclined plane **201** and a top surface of the first region may have a flat surface.

Here, a flat surface formed in a top surface of the second region may be in parallel to a flat surface formed in a back surface of the second region.

At this time, in the first region, the thickness (t1) of a predetermined area adjacent to the light source module may be smaller than the thickness (t2) of an area distant from the light source module.

In the second region, the thickness of a predetermined area adjacent to the light source module may be larger than the thickness (t4) of an area distant from the light source module.

Also, in the top surface of the first reflector **200**, the first region may be a flat surface and the second region may be a stepped surface having two flat surfaces with different heights.

As shown in FIG. **6B**, the first reflector **200** may include a first region adjacent to the light source module and a second region adjacent to the first region.

Here, a back surface of the first region disposed in the first reflector **200** may have an inclined plane **201** and a top surface of the first region may have an inclined plane.

In other words, the back and top surfaces of the first region may have the same inclined planes, respectively.

A back surface of the second region disposed in the first reflector **200** may have a flat surface **202** and a top surface of the second region may have a flat surface.

Here, the top surface of the second region may partially have an inclined plane and the flat surface of the top surface may be in parallel to the flat surface of the back surface.

At this time, in the first region, the thickness (t1) of an area adjacent to the light source module may be the same as the thickness (t2) of an area distant from the light source module.

In the second region, the thickness (t3) of an area adjacent to the light source module may be the same as the thickness (t4) distant from the light source module.

Also, in the top surface of the first reflector, the first region may be an inclined plane and the second region may be combined with an inclined plane and a flat surface.

FIGS. **7A** and **7B** are sectional views illustrating the width of the top surface of the first reflector.

First of all, as shown in FIG. **7A**, the top surface of the first reflector **200** may include a third region **203** adjacent to the light source module and a fourth region **204** adjacent to the third region **203**.

Here, the third region **203** disposed in the top surface of the first reflector **200** may be corresponding to the inclined plane disposed in the back surface of the first reflector **200** and the fourth region **204** disposed in the top surface of the first reflector **200** may be corresponding to the flat surface disposed in the back surface of the first reflector **200**.

Here, the third region **203** and the fourth region **204** may be flat surfaces located on different lines.

In other words, the flat surface of the third region **203** may be higher than the flat surface of the fourth region **204**.

The width of the third region **203** may be different from the width of the fourth region **204**.

That is, the width of the flat surface formed in the third region **203** may be different from the width of the flat surface disposed in the fourth region **204**. For example, the width of the flat surface disposed in the third region **203** may be larger than the width of the flat surface disposed in the fourth region **204**.

That is because an active region of the display can be increased by reducing the width of the fourth region **204** and by reducing the width of the bezel accordingly.

In some case, the widths of the third and fourth regions **203** and **204** may be the same.

As shown in FIG. 7B, the top surface of the first reflector **200** may include a third region **203** adjacent to the light source module and a fourth region **204** adjacent to the third region **203**.

Here, the third region **203** disposed in the top surface of the first reflector **200** may be corresponding to the inclined plane disposed in the back surface of the first reflector **200** and the fourth region **204** disposed in the top surface of the first reflector **200** may be corresponding to the flat surface disposed in the back surface of the first reflector **200**.

Here, the third region **203** may be a downwardly inclined plane and the fourth region **204** may be a flat surface in parallel to the back surface.

The width of the third region **203** may be different from the width of the fourth region **204**.

In other words, the width of the flat surface disposed in the third region **203** may be different from the width of the flat surface disposed in the fourth region **204**.

That is because an active region of the display can be increased by reducing the width of the fourth region **204** and by reducing the width of the bezel accordingly.

In some cases, the widths of the third and fourth regions **203** and **204** may be the same.

The third region **203** and the fourth region **204** disposed in the top surface of the first reflector **200** may have the surfaces having the same appearance. Alternatively, they may have surfaces having different appearances, respectively.

The surfaces of the third and fourth regions **203** and **204** may be curved or flat and they may be fabricated in various shapes rather than the curved or flat shapes.

FIGS. 8A and 8B are sectional views illustrating a projection projected from the top surface of the first reflector.

As shown in FIGS. 8A and 8B, the top surface of the first reflector **200** may include at least one projection projected with a predetermined height.

In an embodiment shown in FIG. 8A, the top surface of the first reflector **200** may include a third region **203** adjacent to the light source module and a fourth region **204** adjacent to the third region **203**. The third and fourth regions **203** and **204** may have flat surfaces located on a different line, respectively.

Here, a first projection **211** and a second projection **212** may be disposed on the flat surface of the third region **203**. A third projection **213** may be disposed on the flat surface of the fourth region **204**.

At this time, the height (h1) of the first projection **211**, the height (h2) of the second projection **212** and the height (h3) of the third projection **213** may be the same. In some cases, at least one of the heights (h1, h2 and h3) possessed by the first, second and third projections **211**, **212** and **213**, respectively, may be the same. Alternatively, at least one of the heights (h1, h2 and h3) possessed by the first, second and third projections **211**, **212** and **213**, respectively, may be different from the others.

In an embodiment shown in FIG. 8B, the top surface of the first reflector **200** may include a third region **203** adjacent a fourth region **204** adjacent to the third region **203**. The third

and fourth regions **203** and **204** may have flat surfaces located on a different line, respectively.

Here, a first projection **211** and a second projection **212** may be disposed on the flat surface of the third region **203**. A third projection **213** may be disposed on the flat surface of the fourth region **204**.

At this time, the height (h1) of the first projection **211**, the height (h2) of the second projection **212** and the height (h3) of the third projection **213** may be the same. In some cases, at least one of the heights (h1, h2 and h3) possessed by the first, second and third projections **211**, **212** and **213**, respectively, may be the same. Alternatively, at least one of the heights (h1, h2 and h3) possessed by the first, second and third projections **211**, **212** and **213**, respectively, may be different from the others.

Although not shown in the drawings, the first, second and third projections **211**, **212** and **213** may be employed to support or couple optical members or panel guide molds.

For example, the first and second projections **211** and **212** may be members configured to be coupled with a panel guide mold to fix or support the display panel. The third projection **213** may be a member to support the optical members.

Here, a top surface of the third projection may be a convex surface with a predetermined curvature to reduce the contact area with the optical members. As a result, the optical member may be protected from an external shock.

In some cases, a plurality of hollownesses or minute projections may be further formed in the top surface of the third projection **213**.

FIGS. 9A to 9D are sectional views illustrating a reflection pattern formed in the first reflector.

As shown in FIGS. 9A to 9D, the first reflector **200** may include the inclined plane **201** and the flat surface **202** formed in the back surface thereof. A plurality of reflection patterns **215** may be formed on the flat surface **202**.

In FIG. 9A, the reflection pattern **215** may be saw-toothed and a surface of the reflection pattern **215** may be flat. In FIGS. 9B and 9C, the reflection pattern **215** may be saw-toothed and the surface of the reflection pattern **215** may be curved.

Here, in FIG. 9B, the surface of the reflection pattern **215** may be concavely curved and in FIG. 9C, the surface of the reflection pattern **215** may be convexly curved.

In some cases, as shown in FIG. 9C, the size of the reflection patterns **215** may be getting larger from an end of the first reflector **200** toward the other end thereof.

In other words, the size of the reflection pattern **215** may not be uniform. The size of a reflection pattern **215** close to the light source module may be larger than the size of another reflection pattern **215** distant from the light source module.

The reason why the reflection patterns **215** are formed on the flat surface of the first reflector **200** is that uniform brightness can be provided by compensating brightness after reflecting the light toward the region having relatively low brightness, compared with the other region.

As a result, such the reflection patterns **215** may be fabricated in corresponding regions, with various sizes according to the entire brightness distribution of the backlight.

FIGS. 10A to 10C are sectional views illustrating the length of the first reflector.

As shown in FIGS. 10A to 10C, the second reflector **300** may include a first region adjacent to the light source module **100** and a second region adjacent to the third region.

The first region of the second reflector **300** may be aligned with the light source module **100** and the first reflector and it may have a first inclined plane inclined downwardly.

The second region of the second reflector **300** may be a flat surface in parallel to the flat surface disposed in the back surface of the first reflector or it may include a second inclined plane inclined upwardly.

The back surface of the first reflector **200** may include an inclined plane **201** adjacent to the light source module **100** and a flat surface **202** adjacent to the inclined plane **201**. The flat surface **202** disposed in the back surface of the first reflector **200** may be aligned in at least one of the first and second regions disposed in the second reflector **300**.

FIG. **10A** illustrates an embodiment in that the flat surface **202** disposed in the back surface of the first reflector **200** is aligned in the first region of the second reflector **300**. FIG. **10B** illustrates an embodiment in that the flat surface **202** disposed in the back surface of the first reflector **200** is aligned over the first region and the second region. FIG. **10C** illustrates an embodiment in that the flat surface **202** disposed in the back surface of the first reflector **200** is aligned in the second region of the second reflector **300**.

As mentioned above, the length of the first reflector **200** may be variable according to various embodiments.

FIGS. **11A** to **11D** are sectional views illustrating an arrangement relation between the light source module and the first and second reflectors.

FIG. **11A** illustrates the light source module **100** spaced apart a predetermined distance from the first and second reflectors **200** and **300**. FIG. **11B** illustrates the light source module **100** in contact with the first and second reflectors **200** and **300** simultaneously. FIG. **11C** illustrates the light source module **100** spaced apart a predetermined distance from the second reflector **300**, in contact with the first reflector **200** simultaneously. FIG. **11D** illustrates the light source module **100** spaced apart a predetermined distance from the first reflector **200**, in contact with the second reflector **300** simultaneously.

As shown in FIG. **11A**, the light source module **100** may be spaced apart a first distance (d_1) from the first reflector **200** and a second distance (d_2) from the second reflector **300**.

Here, the first distance (d_1) and the second distance (d_2) may be the same or different from each other.

For example, the first distance (d_1) may be smaller than the second distance (d_2).

If the first distance (d_1) is larger than the second distance (d_2), a hot spot may be generated.

As shown in FIG. **11B**, the light source module **100** may be in contact with the first reflector **200** and the second reflector **300**.

Here, the light source module **100** may be in contact with the first and second reflectors **200** and **300**, to prevent the hot spot and to transfer the light to a region distant from the light source **100** to reduce the overall thickness of the backlight unit.

As shown in FIG. **11C**, the light source module **100** may be in contact with the first reflector **200** and it may be spaced apart a predetermined distance (d) from the second reflector **300**.

Here, the light source module **100** may be in contact with the first reflector **200**, to prevent the hot spot and to transfer the light to a region distant from the light source module **100**.

As shown in FIG. **11D**, the light source module **100** may be in contact with the second reflector **300** and it may be spaced apart a predetermined distance (d) from the first reflector **200**.

FIGS. **12A** to **12C** are sectional views illustrating the second reflector including the inclined plane and the flat surface.

FIG. **12A** illustrates the inclined plane of the second reflector **300** is flat and FIG. **12B** illustrates the inclined plane of the

second reflector **300** is concavely curved. FIG. **12C** illustrates the inclined plane of the second reflector **300** is convexly curved.

Here, a first region of the second reflector **300** may be the inclined plane and a second region may be the flat surface.

FIGS. **13A** to **13C** are sectional views illustrating the second reflector including a plurality of inclined planes.

In FIG. **13A**, two neighboring inclined planes have flat surfaces, respectively. In FIG. **13B**, two neighboring inclined planes have concavely curved surfaces and the curvatures of the two inclined planes may be different from each other. In FIG. **13C**, two neighboring inclined planes may have convex curved surfaces and the curvatures of the two inclined planes may be different from each other.

As shown in FIGS. **13A** to **13C**, the second reflector **300** may include a first region adjacent to the light source **100** and a second region distant from the light source module **100**.

Here, the first region and the second region of the second reflector **300** may be inclined planes.

In the meanwhile, a specular-reflection sheet may be formed on the first region of the second reflector **300** to specular-reflect the light. At least one of the specular-reflection sheet and scattered-reflection sheet may be formed on the second region of the second reflector **300**.

Here, the reason why the specular-reflection sheet is formed on the first region of the second reflector **300** is that uniform brightness can be provided by reflecting more light toward the central region of the second reflector **300** having lower brightness.

Also, the reason why the scattered-reflection sheet is formed on the second region of the second reflector **300** is that the lower brightness can be compensated by scattered-reflecting the light in the second region of the second reflector **300** having the lower brightness.

The second reflector **300** may include a metal material or a metal oxide with a high reflectivity such as Al, Ag, Au and TiO₂. The materials forming the first and second regions of the second reflector **300** may be different from each other and surface roughness of the first region may be different from surface roughness of the second region.

In other words, the first and second regions of the second reflector **300** may be formed of the same materials, with a different surface roughness.

Alternatively, the first and second regions of the second reflector **300** may be formed of different materials, and surface roughness of them may be different from each other simultaneously.

In the meanwhile, the second reflector **300** may be a reflection coating film or a reflection coating material layer having a reflection material deposited thereon.

The second reflector **300** may include at least one of a metal material and a metal oxide. For example, the second reflector **300** may include a metal material or a metal oxide with a high reflectivity such as Al, Ag, Au and TiO₂.

In this case, the second reflector **300** may be formed by depositing or coating the metal material or the metal oxide on a polymer resin frame **430** that is a bottom plate or it may be formed by printing metal ink.

Here, the depositing method may be thermal deposition, vapor deposition or vacuum deposition such as sputtering. The coating or printing method may be printing, gravure printing or silk printing.

In addition, the second reflector **300** may be a film or sheet and it may be bonded on the polymer resin frame.

Here, the second reflector **300** may have the structure having a unilayer with the uniform reflectivity formed on an entire region of the polymer resin frame that is the bottom

11

plate. The second reflector **300** may have the structure having multi-layers with different reflectivity, respectively, formed on the entire region of the polymer resin frame.

The reason why the second reflector **300** includes the multi-layers with the different reflectivity is that the overall brightness of the backlight might fail to be uniform because the light reflectivity of the overall reflection surface is not uniform in case of forming only the reflection layer having the same reflectivity.

As a result, a reflection layer with a relatively high reflectivity may be formed on a region with a high brightness in the reflection surface or a reflection layer with a relatively low reflectivity may be formed on a region with a higher brightness in the reflection surface. Because of that, the overall brightness of the backlight may be compensated uniformly.

FIG. **14** is a diagram illustrating a backlight unit having an optical member disposed thereon.

As shown in FIG. **14**, an optical member **600** may be disposed, spaced apart a predetermined distance from the second reflector **300**.

An air guide may be formed in the space between the second reflector **300** and the optical member **600**.

Here, an unevenness pattern **620** may be formed on a top surface of the optical member **600**.

The optical member **600** may be configured to disperse the light emitted from the light source module **100** and the unevenness pattern **620** may be formed to increase a dispersion effect.

In other words, the optical member **600** may be configured of a plurality of layers and the unevenness pattern **620** may be disposed on the uppermost layer or a surface of one of the layers.

The unevenness pattern **620** may have a strip shape disposed along the light source module **100**.

At this time, the unevenness pattern **620** may include projected portions projected from the surface of the optical member **600** and each of the projected portions may be configured of a first surface and a second surface facing each other. An angle formed between the first surface and the second surface may be an acute angle or an obtuse angle.

In some cases, the optical member **600** may be configured of at least one sheet and it may selectively include a diffusion sheet, a prism sheet or a brightness enhancement sheet.

Here, the diffusion sheet may diffuse the light emitted from the light source and the prism sheet may guide the diffused light toward a luminescence region. The brightness enhancement sheet may enhance brightness.

Furthermore, the second reflector **300** may include at least one of a metal material and a metal oxide. For example, the second reflector **300** may include a metal material or metal oxide with a high reflectivity such as Al, Ag, Au or TiO₂.

Also, the second reflector **300** may be formed of a reflection coating film or a reflection coating material layer and it may be employed to reflect the light generated in the light source module **100** toward the optical member **600**.

The second reflector **300** may have a saw-toothed reflection pattern formed on a surface thereof facing the optical member **600**. The reflection pattern may be a flat surface or a curved surface.

The reason why the reflection pattern is formed on the surface of the second reflector **300** is that the light generated in the light source module **100** can be diffused and reflected uniformly.

According to the embodiments, the reflector for air guiding may include the flat surface or the inclined plane. Because of that, the weight of the backlight unit may be reduced and the

12

fabricating cost of the backlight unit may be lowered. Also, the backlight unit may provide uniform brightness.

As a result, the economic feasibility and reliability of the backlight unit may be enhanced.

FIG. **15** is a diagram illustrating a display module including the backlight unit according to the embodiments mentioned above.

As shown in FIG. **15**, a display module **20** may include a display panel **800** and a backlight unit **700**.

The display panel **800** may include a color filter substrate **810** and a thin film transistor substrate **820** (TFT) that are bonded to maintain a uniform cell gap, facing each other. A liquid crystal layer (not shown) may be disposed between the two substrates **810** and **820**.

A top polarization plate **830** and a bottom polarization plate **840** may be disposed on and under the display panel **800**, respectively. More specifically, the top polarization plate **830** may be disposed on a top surface of the color substrate **810** and the bottom polarization plate **840** may be disposed under the TFT substrate **820**.

Although not shown in the drawings, gate and data driving parts may be disposed in both sides next to the display panel **800** to generate a driving signal used to drive the panel **800**.

FIGS. **16** and **17** are diagrams illustrating a display device according to an embodiment.

In reference to FIG. **16**, a display device **1** may include a display module **20**, a front cover **30** and a back cover **35** surrounding the display module **20**, a driving part **55** disposed in the back cover **35** and a driving cover **40** surrounding the driving part **55**.

The front cover **30** may include a front panel (not shown) formed of a transparent material to transmit light. The front panel may protect the display module **20**, spaced apart a predetermined distance from the display module **20**, and transmit the light emitted from the display module **20** to enable an image displayed on the display module **20** visible outside.

The back cover **35** may be coupled to the front cover **30**, to protect the display module **20**.

The driving part **55** may be disposed on a surface of the back cover **35**.

The driving part **55** may include a main control part **55a**, a main board **55b** and a power supply part **55c**.

The driving control part **55a** may be a timing controller and it may be driving part that adjusts an operation timing of each driver IC disposed in the display module **20**. The main board **55b** may be a driving part that transmits V-synch, H-synch and R, G and B resolution signals to the timing controller. The power supply part **55c** may be a driving part that applies an electric voltage to the display module **20**.

The driving part **55** may be disposed in the back cover **35** and it may be surrounded by the driving part cover **40**.

A plurality of holes may be disposed in the back cover **35**, to connect the display module **20** and the driving part **55** with each other. A stand **60** may be disposed in the back cover **35** to support the display device **1**.

In contrast, as shown in FIG. **17**, a driving control part **55a** of the driving part may be disposed in the back cover **35** and the power board **55c** of the main board **55b** may be disposed in the stand **60**.

The driving part cover **40** may cover only the driving part **55** disposed in the back cover **35**.

In this embodiment, the main board **55b** and the power board **55c** may be independently disposed or they may compose a single integration board, and this embodiment is not be limited thereto.

Another embodiment may be a display device, a pointing device or a lighting system that includes the first and second reflectors and the light source module described in the embodiments. For example, the lighting system may include a lamp and a streetlamp.

Such the lighting system may be used as a lighting lamp having a plurality of light emitting diodes focused thereon to generate light. Especially, the lighting system may be used as a downlight mounted in a ceiling or wall of a building, with exposing an open portion of a shade.

The embodiments described above may include the reflector for air guide that includes the inclined plane partially, without a light guide plate. The weight of the display device may be reduced and the fabrication cost of the display device may be lowered. Also, the uniform brightness may be provided.

As a result, the economic feasibility and reliability of the backlight unit may be enhanced.

Accordingly, the embodiments may provide a backlight unit and a display device using the same.

In one embodiment, a backlight unit includes a first reflector; a second reflector; and at least one light source module disposed between the first and second reflectors, wherein a back surface of the first reflector may include an inclined plane and a flat surface, with facing the second reflector, and the inclined plane may be adjacent to the light source and the flat surface is extended from an end of the inclined plane, with the inclined plane and the flat surface being collinear.

The inclined plane of the first reflector may be inclined a predetermined angle toward the second reflector and the flat surface of the first reflector is in parallel to the top surface of the first reflector.

The inclined plane of the first reflector may be at least one of a concavely curved surface, a convexly curved surface and a flat surface.

The light source module may include a substrate, at least one light source disposed on the substrate, and the flat surface of the first reflector may be located in a range of the width of the first reflector.

The width of the inclined plane may be the same as or different from the width of the flat surface.

The inclined plane and the flat surface may be specular-reflection regions configured to reflect the light. Or, the inclined plane may be a specular-reflection region configured to specular-reflect the light and the flat surface may be a scattered-reflection region configured to scattered-reflect the light. Or, the inclined plane may be a specular-reflection region and the flat surface may include the specular-reflection region and a scattered-reflection region configured to scattered-reflect the light.

A boundary region between the inclined plane and the flat surface may be a curved surface or includes a dihedral angle.

The first reflector may include a first region having the inclined plane; and a second region having the flat surface, and the thickness of a region adjacent to the light source module may be smaller than the thickness of a region distant from the light source module in the first region, or the thickness of the region adjacent to the light source module may be the same as the thickness of the region distant from the light source module in the first region.

The first reflector may include a first region having the inclined plane; and a second region having the flat surface, and the thickness of a region adjacent to the light source module in the second region may be larger than the thickness of a region distant from the light source module, or the thickness of the region adjacent to the light source module may be

the same as the thickness of the region distant from the light source module in the second region.

A top surface of the first reflector may include a third region corresponding to an inclined plane disposed in a back surface of the first reflector; and a fourth region corresponding to a flat surface disposed in a back surface of the first reflector, and the third region and the fourth region may not be collinear.

Here, the width of the third region may be different from the width of the fourth region. A surface of the third region and a surface of the fourth region may be curved or flat.

A reflection pattern may be formed on the flat surface disposed in the back surface of the first reflector.

Here, the reflection pattern may be saw-toothed and a surface of the reflection pattern is at least one of a flat surface, a concavely curved surface and a convexly curved surface. The size of the reflection pattern may be irregular.

The size of the reflection pattern located adjacent to the light source module may be larger than the size of the reflection pattern located distant from the light source module.

The second reflector may include a first region and a second region, and the first region may be aligned with the light source module and the first reflector and the first region is a first inclined plane inclined downwardly, and the second region may be a flat surface in parallel to a flat surface disposed in a back surface of the first reflector or a second inclined plane inclined upwardly.

Here, the flat surface disposed in the back surface of the first reflector may be aligned in at least one of the first and second regions disposed in the second reflector.

The backlight unit may further include an optical member disposed apart a predetermined distance from the second reflector, wherein air guide may be formed in a space formed between the second reflector and the optical member.

Any reference in this specification to “one embodiment,” “an embodiment,” “example embodiment,” etc., means that a particular feature, structure, or characteristic described in connection with the embodiment is included in at least one embodiment of the invention. The appearances of such phrases in various places in the specification are not necessarily all referring to the same embodiment. Further, when a particular feature, structure, or characteristic is described in connection with any embodiment, it is submitted that it is within the purview of one skilled in the art to effect such feature, structure, or characteristic in connection with other ones of the embodiments.

Although embodiments have been described with reference to a number of illustrative embodiments thereof, it should be understood that numerous other modifications and embodiments can be devised by those skilled in the art that will fall within the spirit and scope of the principles of this disclosure. More particularly, various variations and modifications are possible in the component parts and/or arrangements of the subject combination arrangement within the scope of the disclosure, the drawings and the appended claims. In addition to variations and modifications in the component parts and/or arrangements, alternative uses will also be apparent to those skilled in the art.

What is claimed is:

1. A backlight unit comprising:

a first reflector;

a second reflector; and

at least one light source module disposed between the first and second reflectors,

wherein a surface of the first reflector comprises an inclined plane and a flat surface, with facing the second reflector,

15

the inclined plane is adjacent to the light source module, the flat surface is extended from an end of the inclined plane, and the light source module and the flat surface are disposed collinear,

the second reflector comprises a first region and a second region,

the first region is aligned with the light source module and the first reflector and the first region is a first inclined plane inclined downwardly, and

the second region is a flat surface in parallel to a flat surface disposed in a back surface of the first reflector or a second inclined plane inclined upwardly.

2. The backlight unit according to claim 1, wherein a top surface of the first reflector comprises a third region corresponding to an inclined plane disposed in a back surface of the first reflector and a fourth region corresponding to a flat surface disposed in a back surface of the first reflector, and the third region and the fourth region include at least one projection respectively.

3. The backlight unit according to claim 1, wherein each of the projections has a different height.

4. The backlight unit according to claim 1, wherein a top surface of at least one of the projections is formed in a shape of a convex surface.

5. The backlight unit according to claim 1, further comprising plurality of reflection patterns formed on the flat surface, the reflection patterns are saw-toothed, and a surface of the reflection patterns is flat, convexly curved, or concavely curved.

6. The backlight unit according to claim 5, wherein a size of the reflection pattern located adjacent to the light source module is larger than the size of the reflection pattern located distant from the light source module.

7. The backlight unit according to claim 1, wherein a top surface of the second region has a step.

8. The backlight unit according to claim 1, wherein the first region has different thickness.

9. The backlight unit according to claim 1, wherein the second region has different thickness.

10. The backlight unit according to claim 1, wherein a portion has a smallest thickness in the first region is thicker than a portion has a smallest thickness in the second region.

11. The backlight unit according to claim 1, wherein a top surface of the second reflector comprises a first region adjacent to the light source module and a second region adjacent to first region, the first region has a inclined plane inclined downwardly, and the second region is parallel to the flat surface disposed in the back surface of the first reflector.

12. The backlight unit according to claim 1, wherein the flat surface of the first reflector corresponds to the second region of the second reflector.

13. The backlight unit according to claim 1, wherein the light source module contact with the first reflector and the second reflector.

14. The backlight unit according to claim 1, wherein the first regions and second region of the second reflector have different material.

16

15. The backlight unit according to claim 1, wherein the first regions and second region of the second reflector have different roughness.

16. A backlight unit comprising:

a first reflector;

a second reflector; and

at least one light source module disposed between the first and second reflectors,

wherein a surface of the first reflector comprises an inclined plane and a flat surface, with facing the second reflector, and

the inclined plane is adjacent to the light source module and the flat surface is extended from an end of the inclined plane, and the light source module and the flat surface are disposed collinear, and

at least one of the first reflector and the second reflector is spaced apart from the light source module.

17. The backlight unit according to claim 16, wherein the light source module is spaced apart a first distance from the first reflector and a second distance from the second reflector, and the first distance and the second distance is the same or different from each other.

18. The backlight unit according to claim 16, wherein the second reflector includes at least two inclined planes with at least one inflection point, and curvatures of the two inclined planes are different.

19. The backlight unit according to claim 16, wherein the second reflector includes a first region and a second region, a specular-reflection sheet is formed on the first region, and at least one of the specular-reflection sheet or a scatter-reflection sheet is formed on the second region.

20. A backlight unit comprising:

a first reflector;

a second reflector; and

at least one light source module disposed between the first and second reflectors,

wherein a surface of the first reflector comprises an inclined plane and a flat surface, with facing the second reflector, and

the inclined plane is adjacent to the light source module and the flat surface is extended from an end of the inclined plane, and the light source module and the flat surface are disposed collinear,

the second reflector comprises a first region and a second region,

the first region is aligned with the light source module and the first reflector and the first region is a first inclined plane inclined downwardly,

the second region is a flat surface in parallel to a flat surface disposed in a back surface of the first reflector or a second inclined plane inclined upwardly, and

the light source module is spaced apart a first distance from the first reflector and a second distance from the second reflector, and the first distance and the second distance is the same or different from each other.

* * * * *