



US008802332B2

(12) **United States Patent**
Correa et al.

(10) **Patent No.:** **US 8,802,332 B2**
(45) **Date of Patent:** **Aug. 12, 2014**

(54) **FUEL CELL CURRENT COLLECTOR WITH LOADING MATERIAL DEPOSITED THEREON AND METHOD OF MAKING SAME**

(75) Inventors: **Salvador E. Correa**, Simsbury, CT (US); **Thomas M. Lucas**, Pleasant Valley, CT (US); **Lawrence J. Novacco**, Brookfield, CT (US)

(73) Assignee: **FuelCell Energy, Inc.**, Danbury, CT (US)

(*) Notice: Subject to any disclaimer, the term of this patent is extended or adjusted under 35 U.S.C. 154(b) by 0 days.

(21) Appl. No.: **13/424,028**

(22) Filed: **Mar. 19, 2012**

(65) **Prior Publication Data**
US 2012/0231371 A1 Sep. 13, 2012

Related U.S. Application Data

(62) Division of application No. 11/746,911, filed on May 10, 2007, now Pat. No. 8,137,741.

(51) **Int. Cl.**
H01M 8/06 (2006.01)

(52) **U.S. Cl.**
USPC **429/535**; 429/423; 429/508; 429/510; 429/517

(58) **Field of Classification Search**
None
See application file for complete search history.

(56) **References Cited**

U.S. PATENT DOCUMENTS

3,260,234	A *	7/1966	Serrano et al.	116/206
2002/0022170	A1 *	2/2002	Franklin et al.	429/34
2002/0064593	A1 *	5/2002	Kohler et al.	427/115
2003/0118466	A1 *	6/2003	Yuh et al.	419/2
2003/0121603	A1 *	7/2003	Oh et al.	156/276
2003/0224233	A1 *	12/2003	Kohler et al.	429/30
2004/0157104	A1 *	8/2004	Huang et al.	429/34
2007/0111055	A1 *	5/2007	Katikaneni et al.	429/20

FOREIGN PATENT DOCUMENTS

GB	2296124	A	6/1996
JP	03-291855	A	12/1991
JP	04-215257		8/1992
JP	06-140058		5/1994
JP	08-236127	A	9/1996
JP	10-092447	A	4/1998

* cited by examiner

Primary Examiner — Ula C Ruddock
Assistant Examiner — Tony Chuo

(74) *Attorney, Agent, or Firm* — Cowan, Liebowitz & Latman, P.C.

(57) **ABSTRACT**

A system for fabricating a fuel cell component in which a deposition mechanism deposits loading material particles onto the fuel cell component and an actuation mechanism actuates the deposition mechanism. A unit provides a tape fixing agent to the fuel cell component and loaded material particles so as to retain the particles on the fuel cell component. Other fuel components are retained to the fuel cell component also using a tape fixing agent.

19 Claims, 12 Drawing Sheets

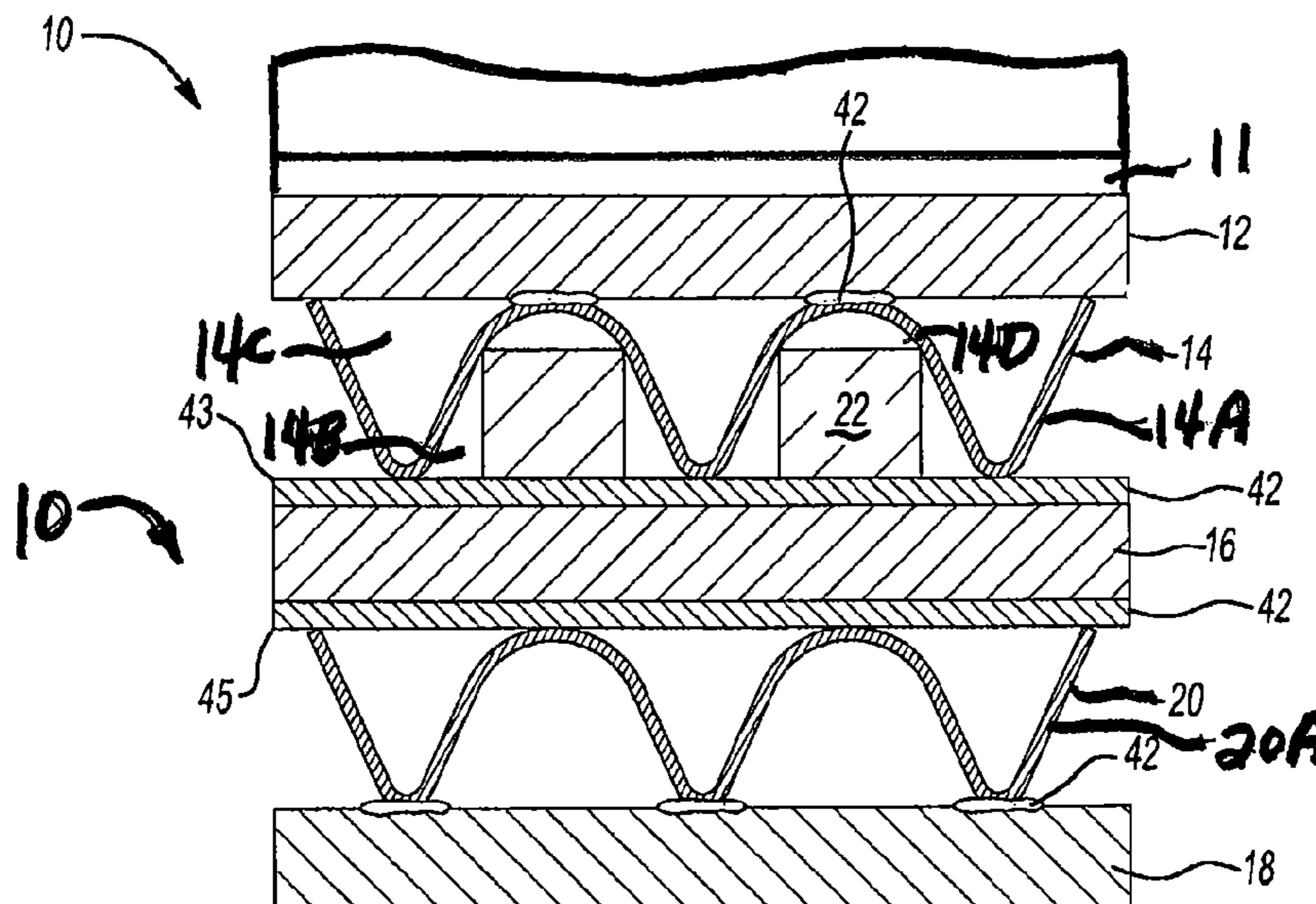

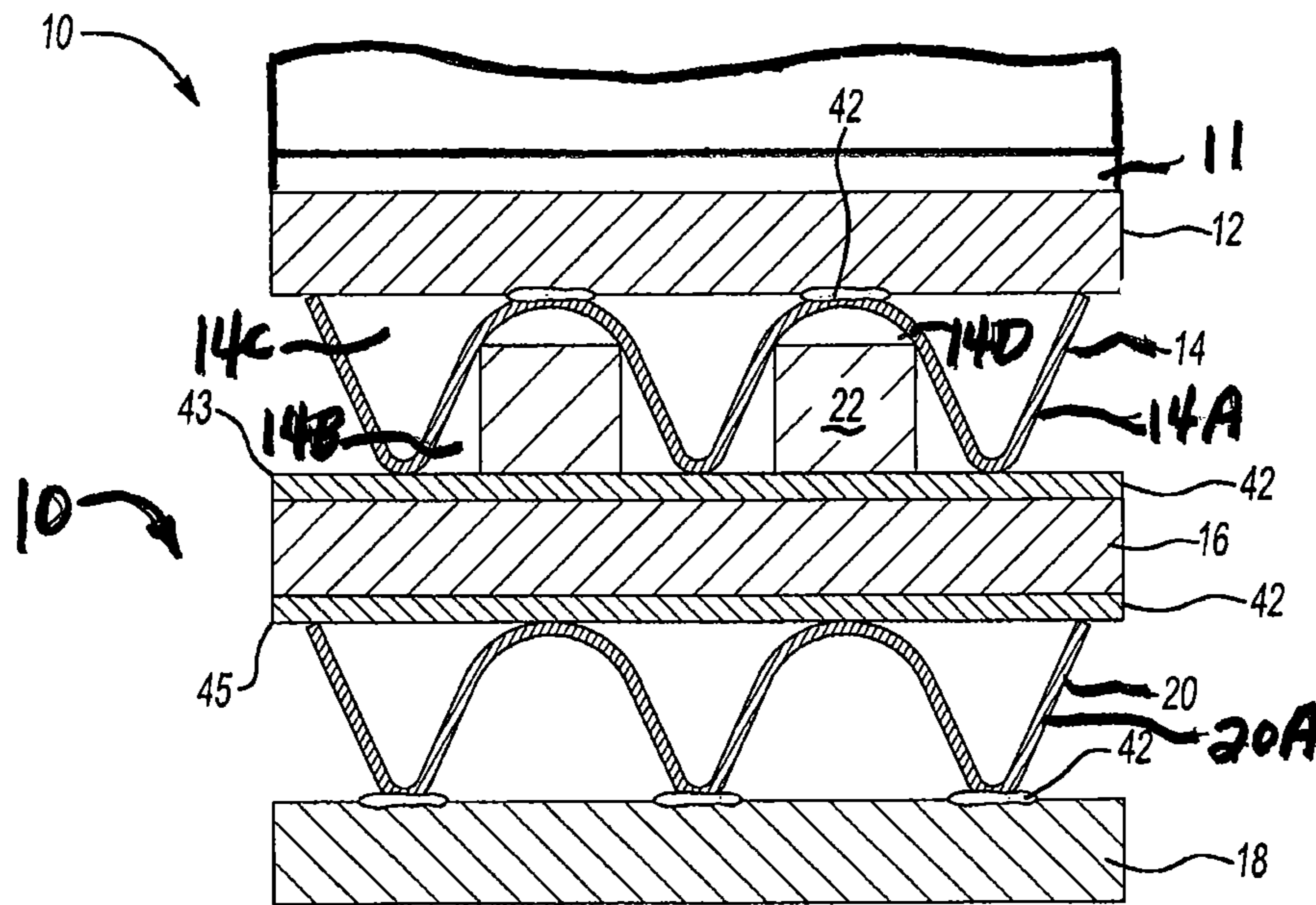

Fig-1

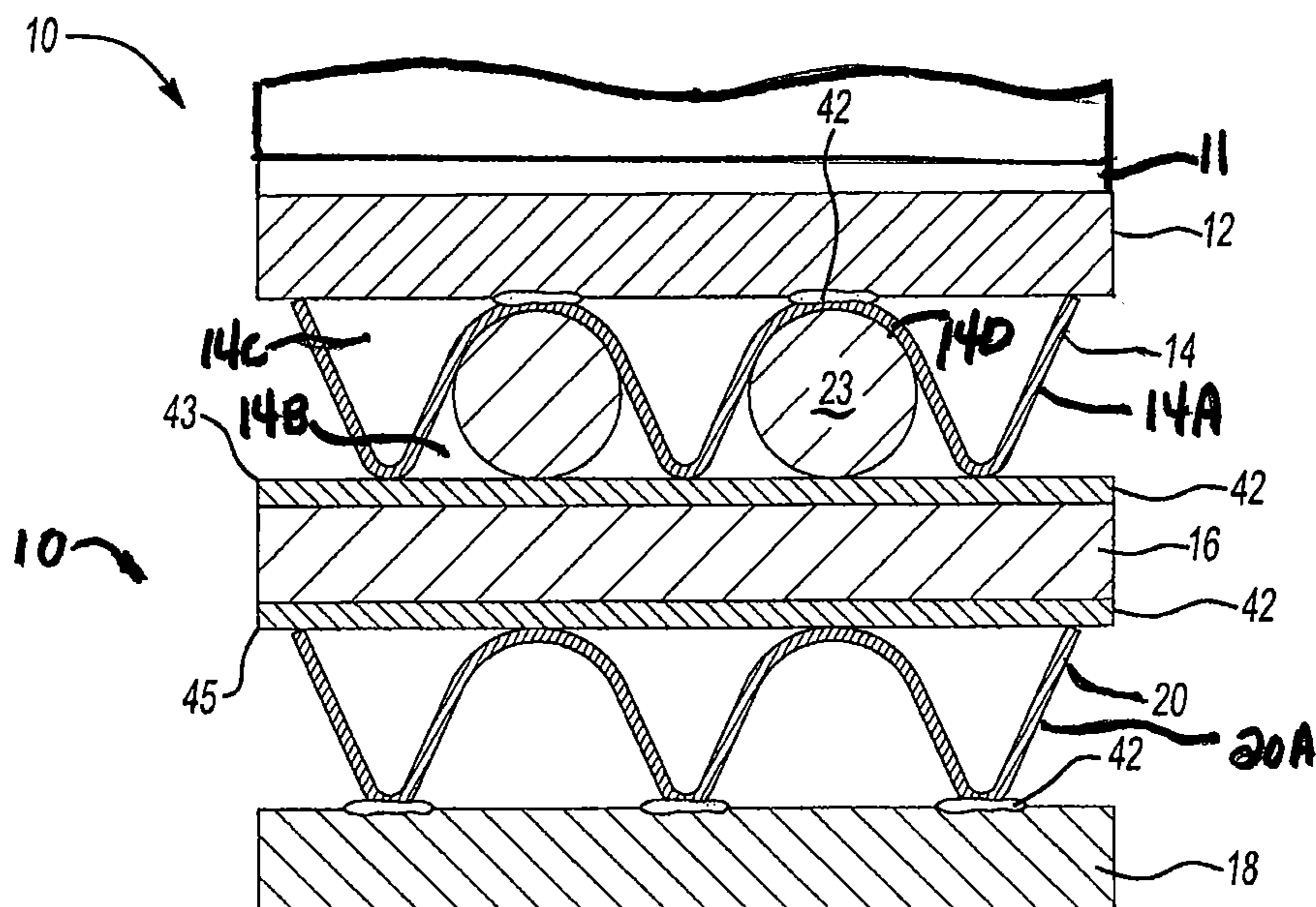

Fig-1A

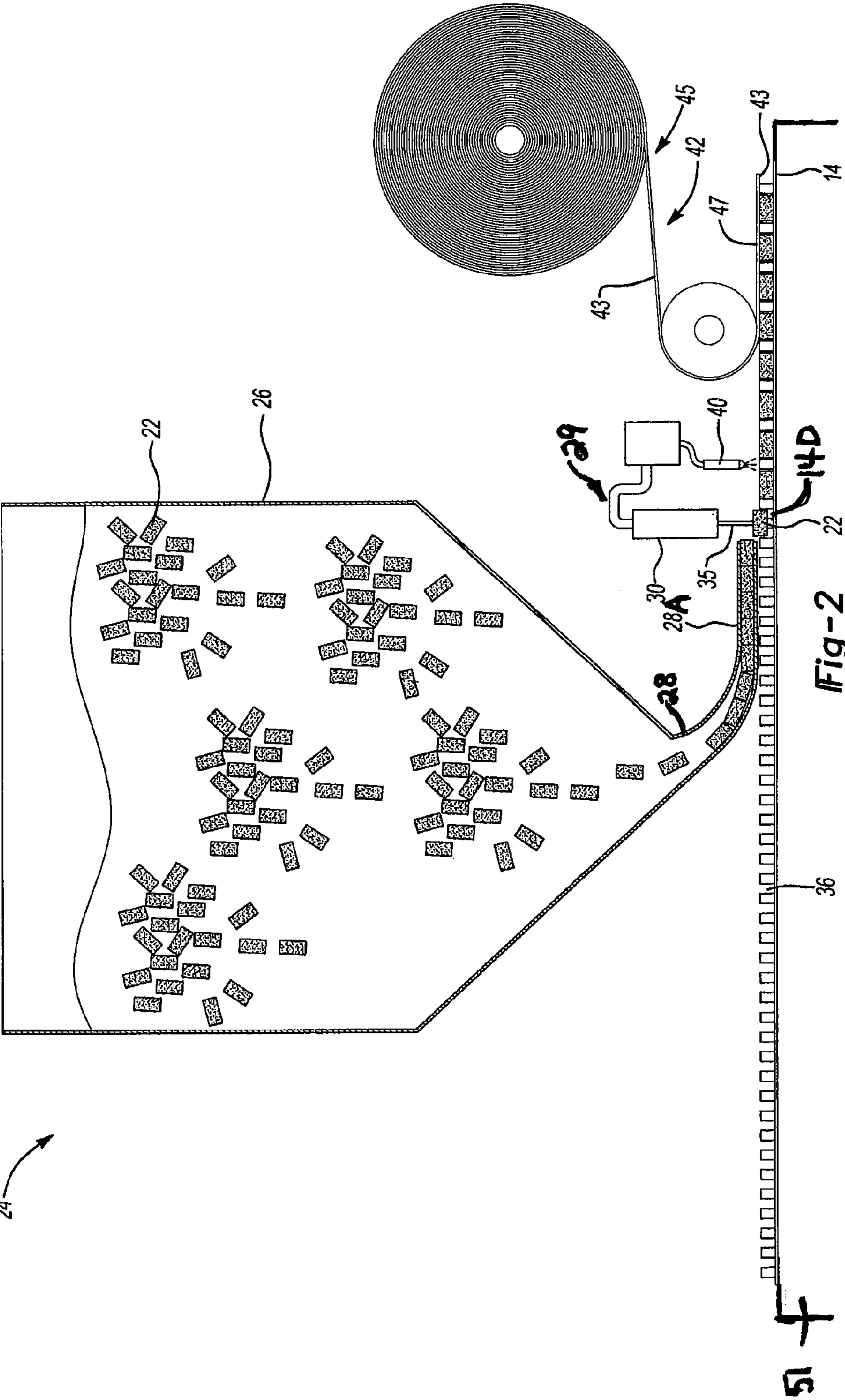
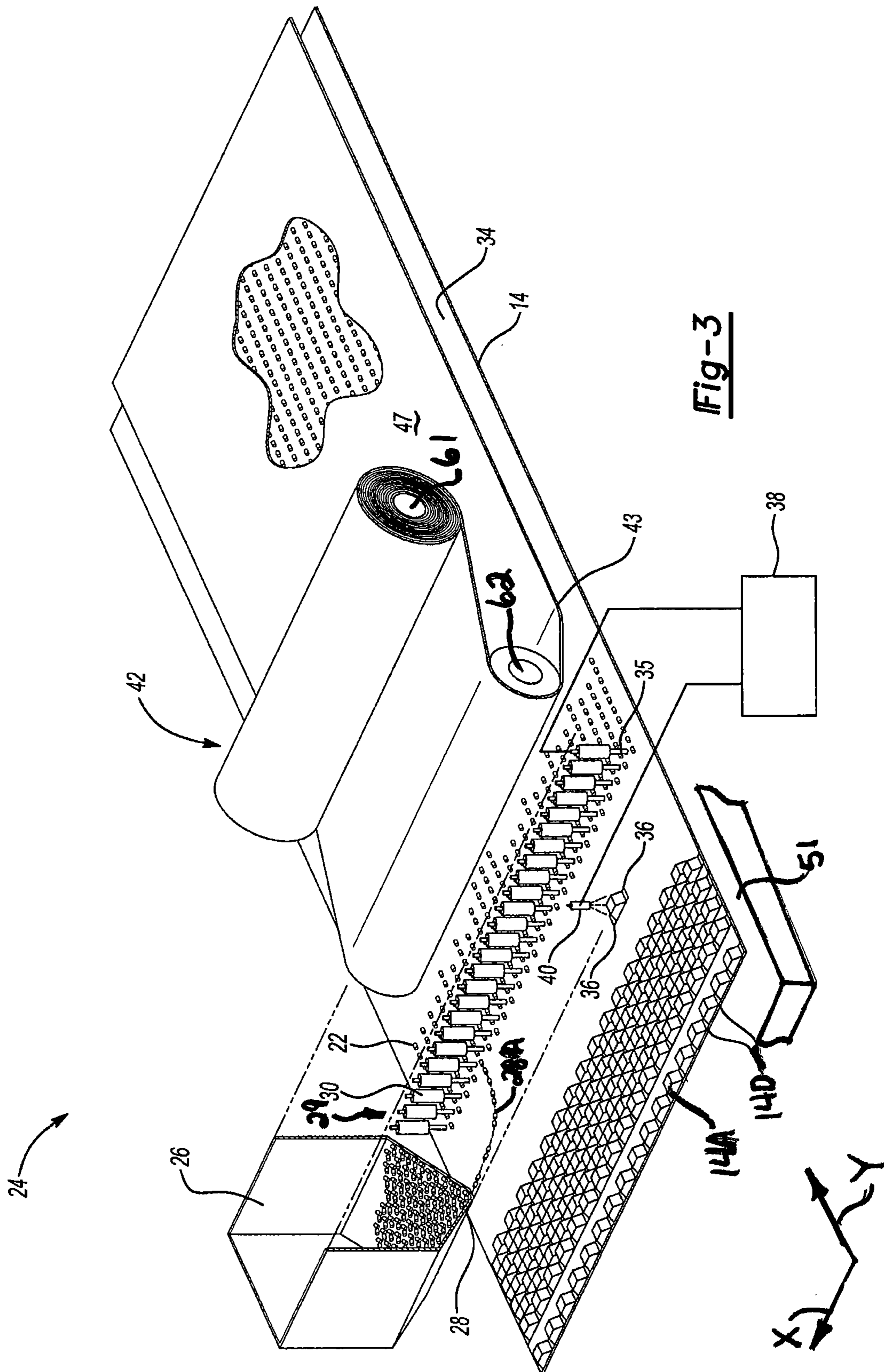

Fig-2

51



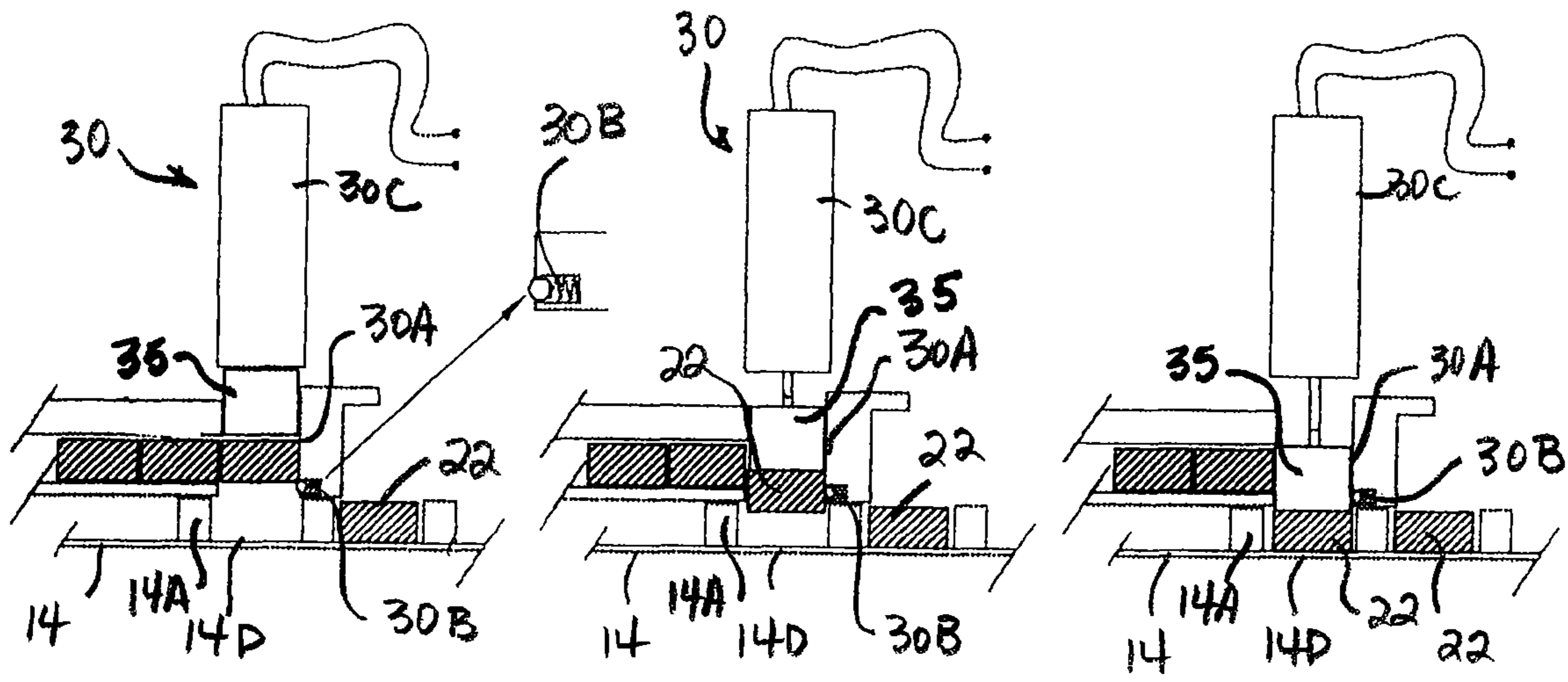

FIG. 3A

FIG. 3B

FIG. 3C

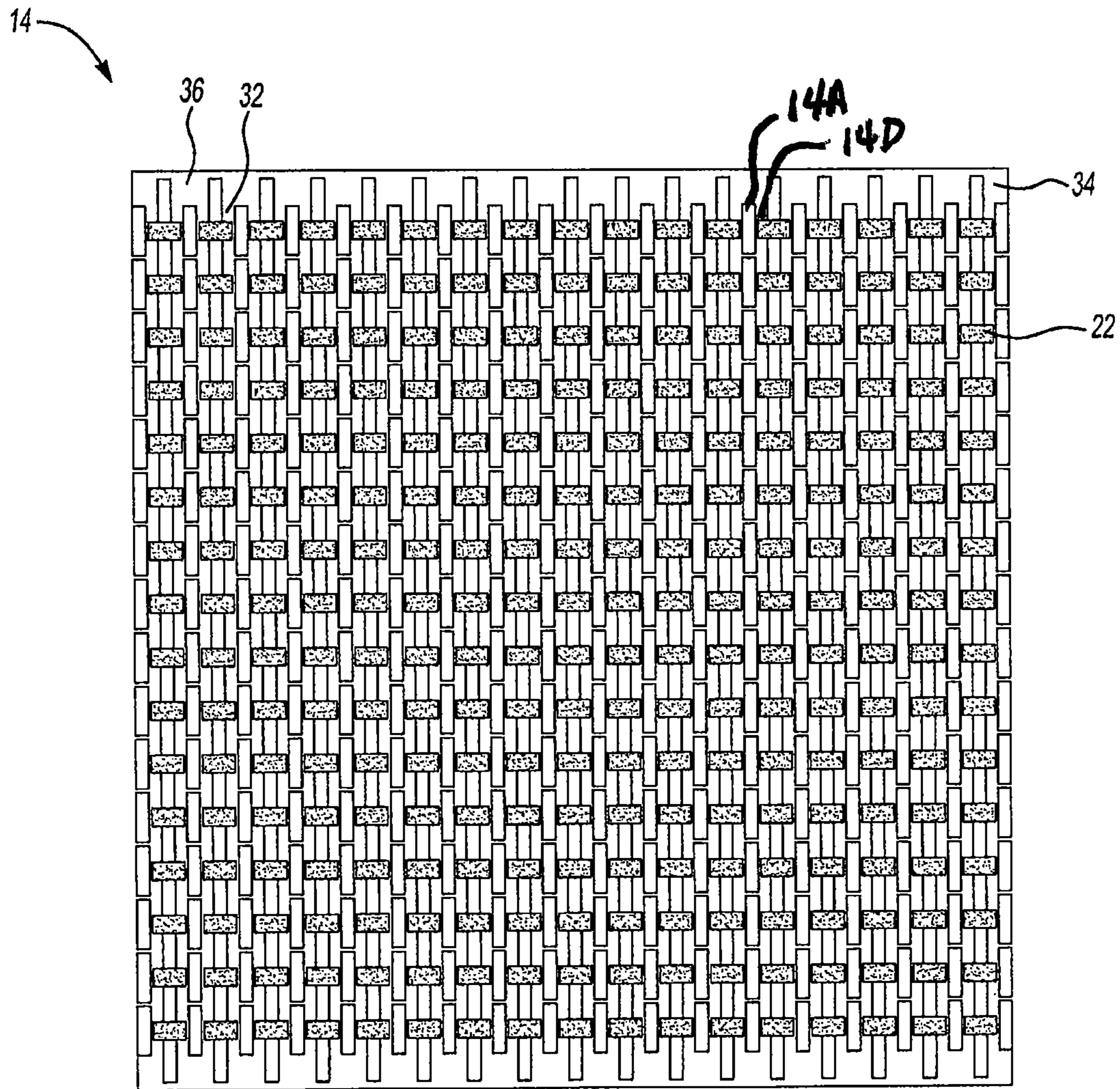

Fig-4

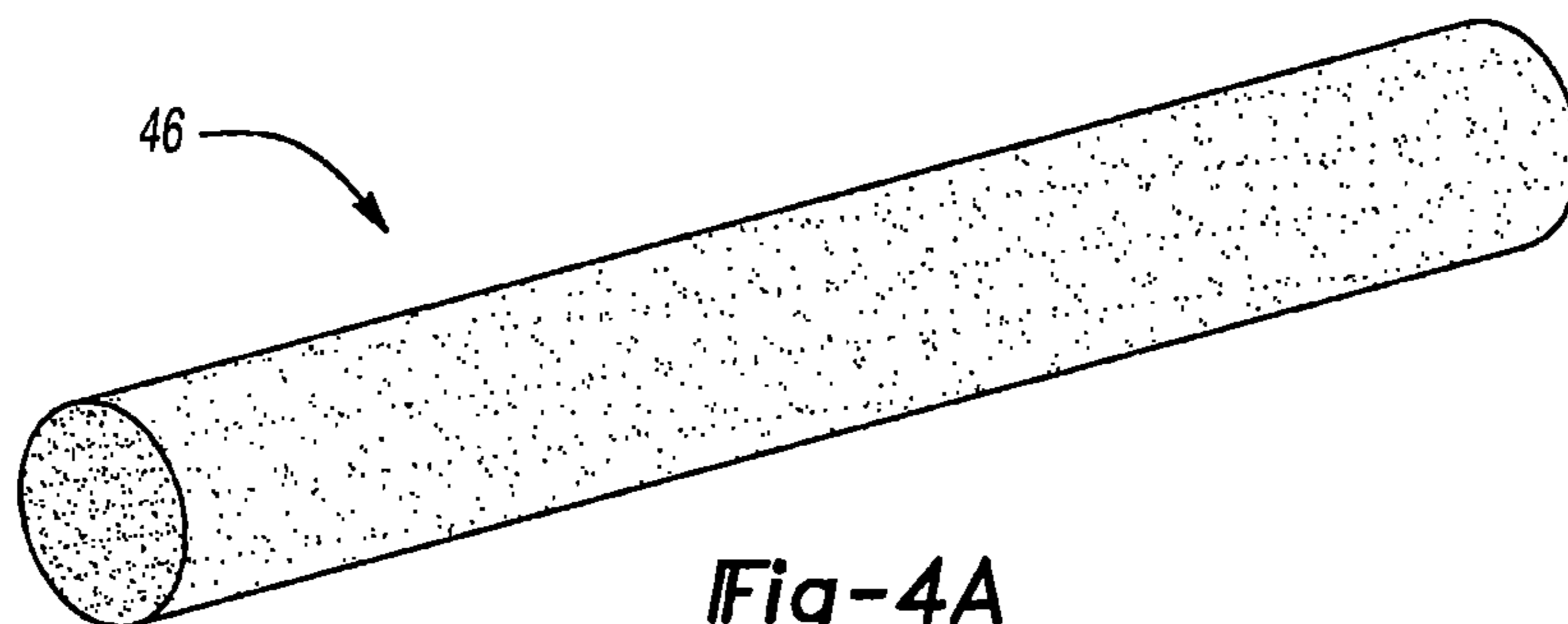

Fig-4A

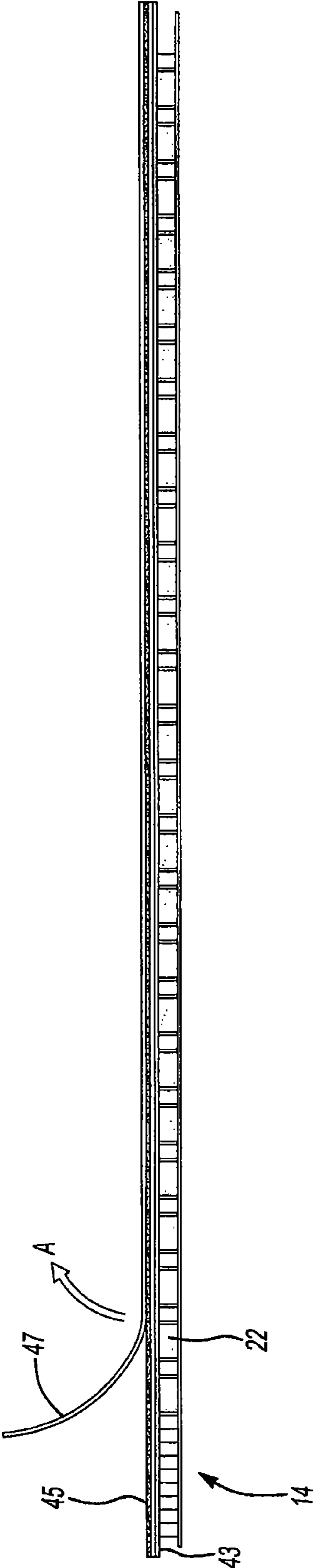

Fig-5

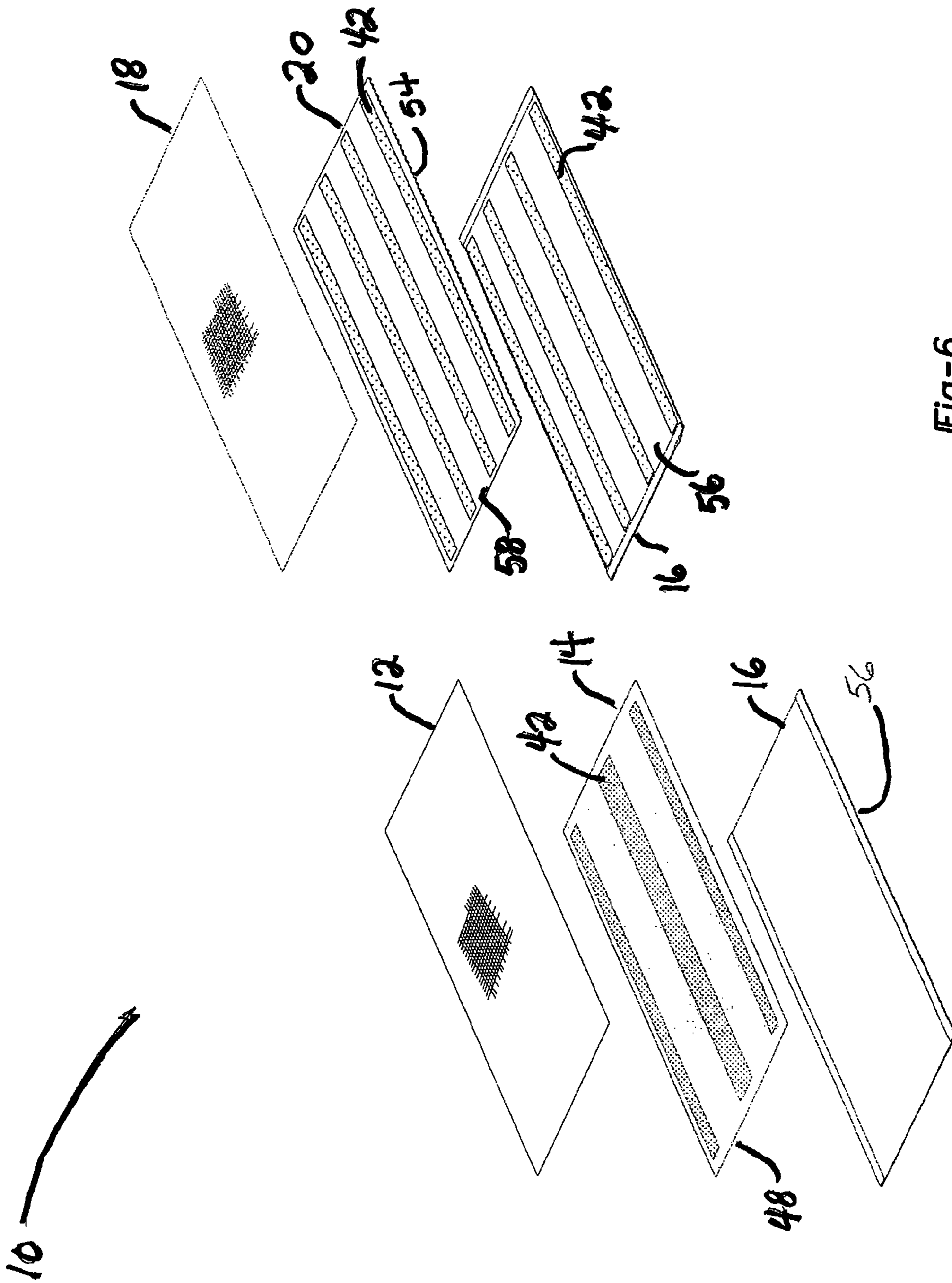

Fig-6

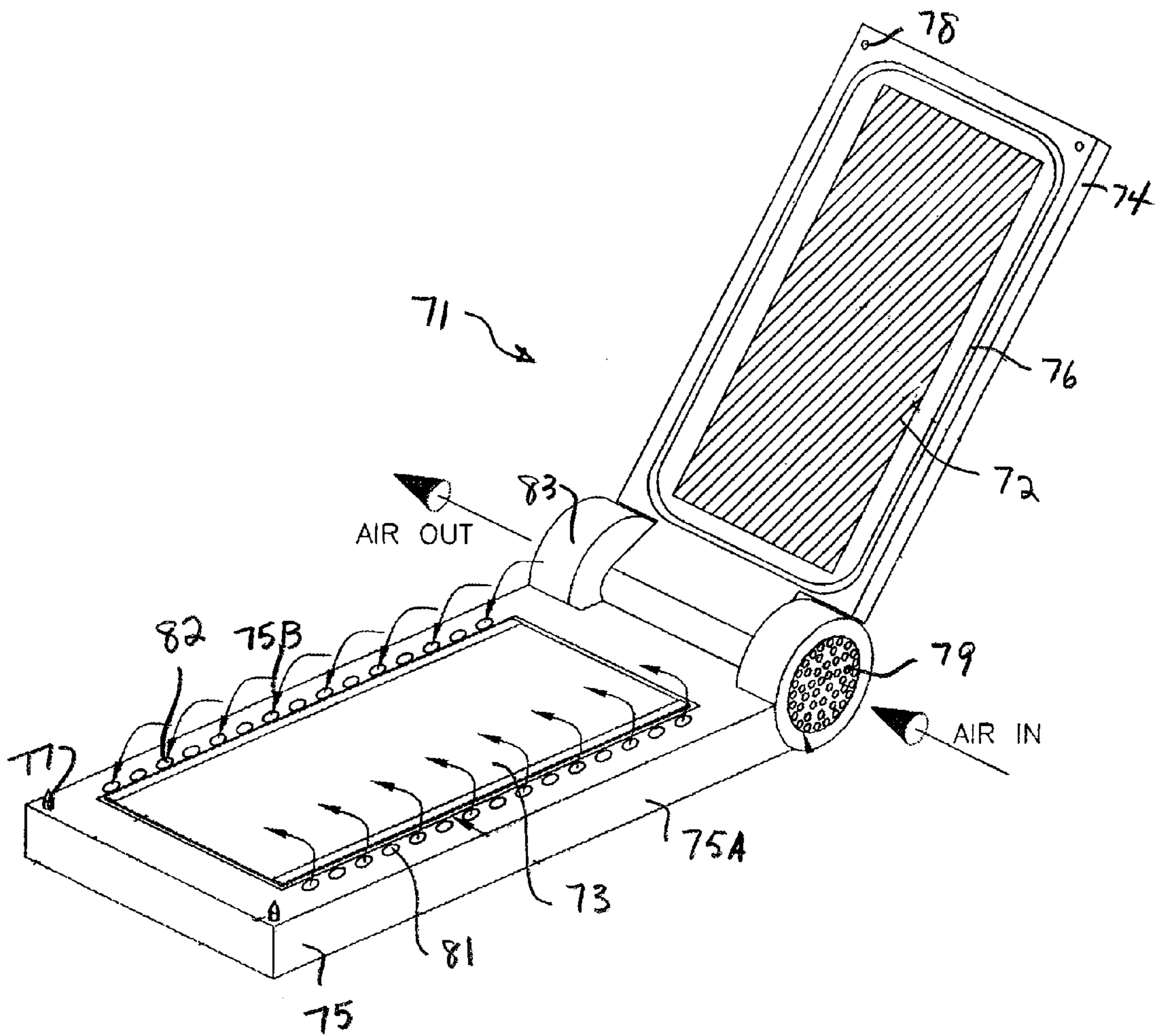

FIG. 7

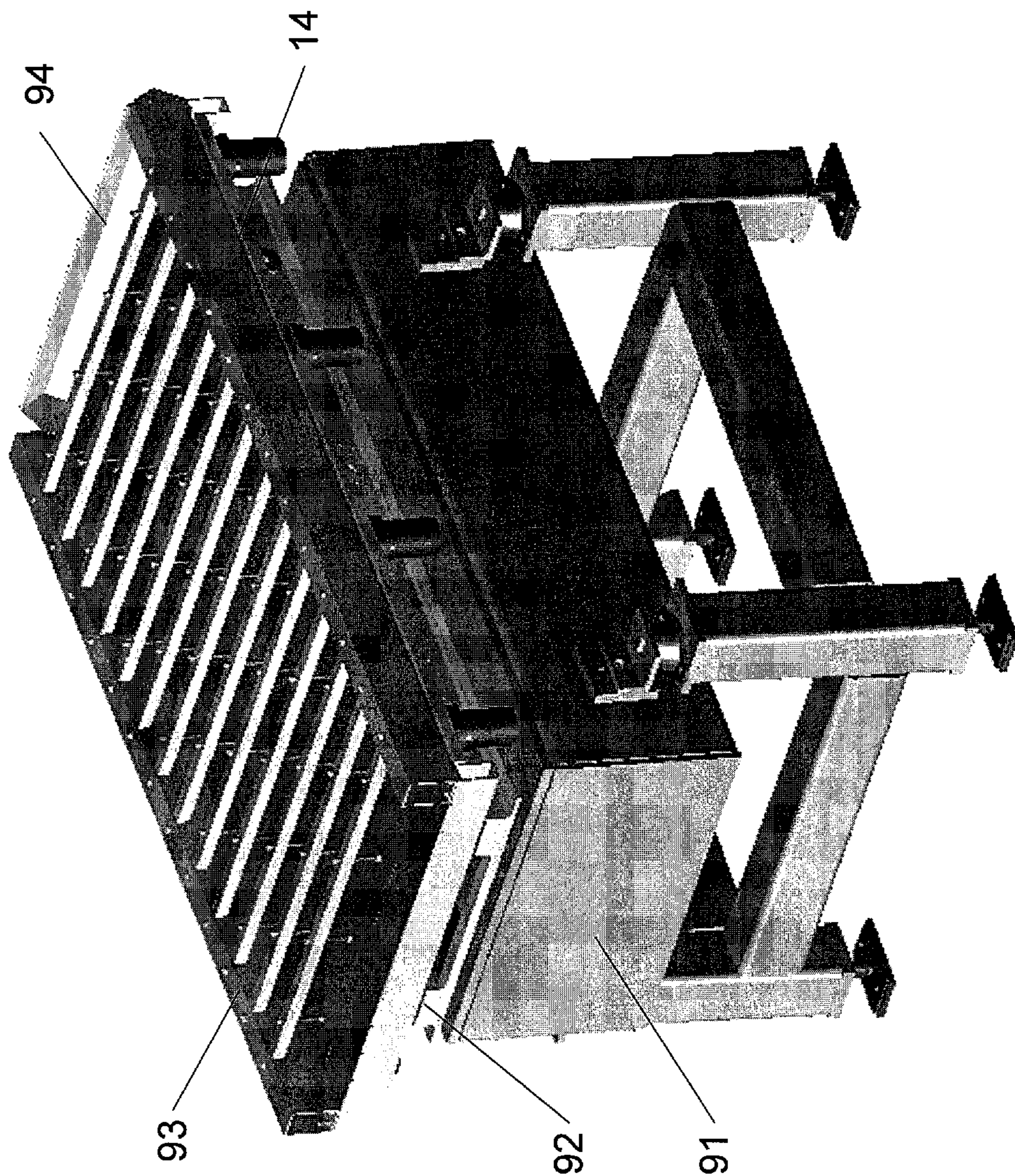

Fig. 8

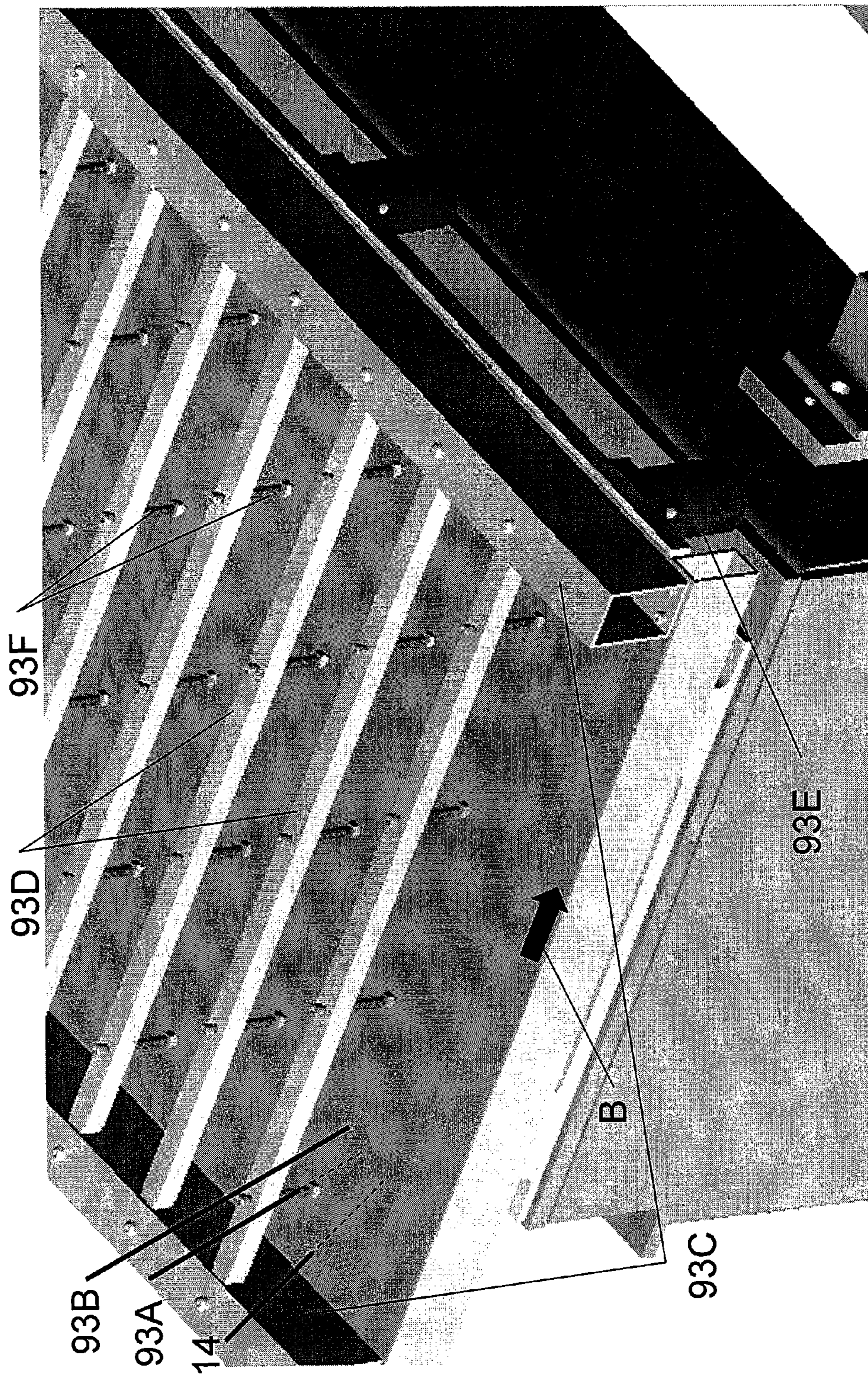

Fig. 9

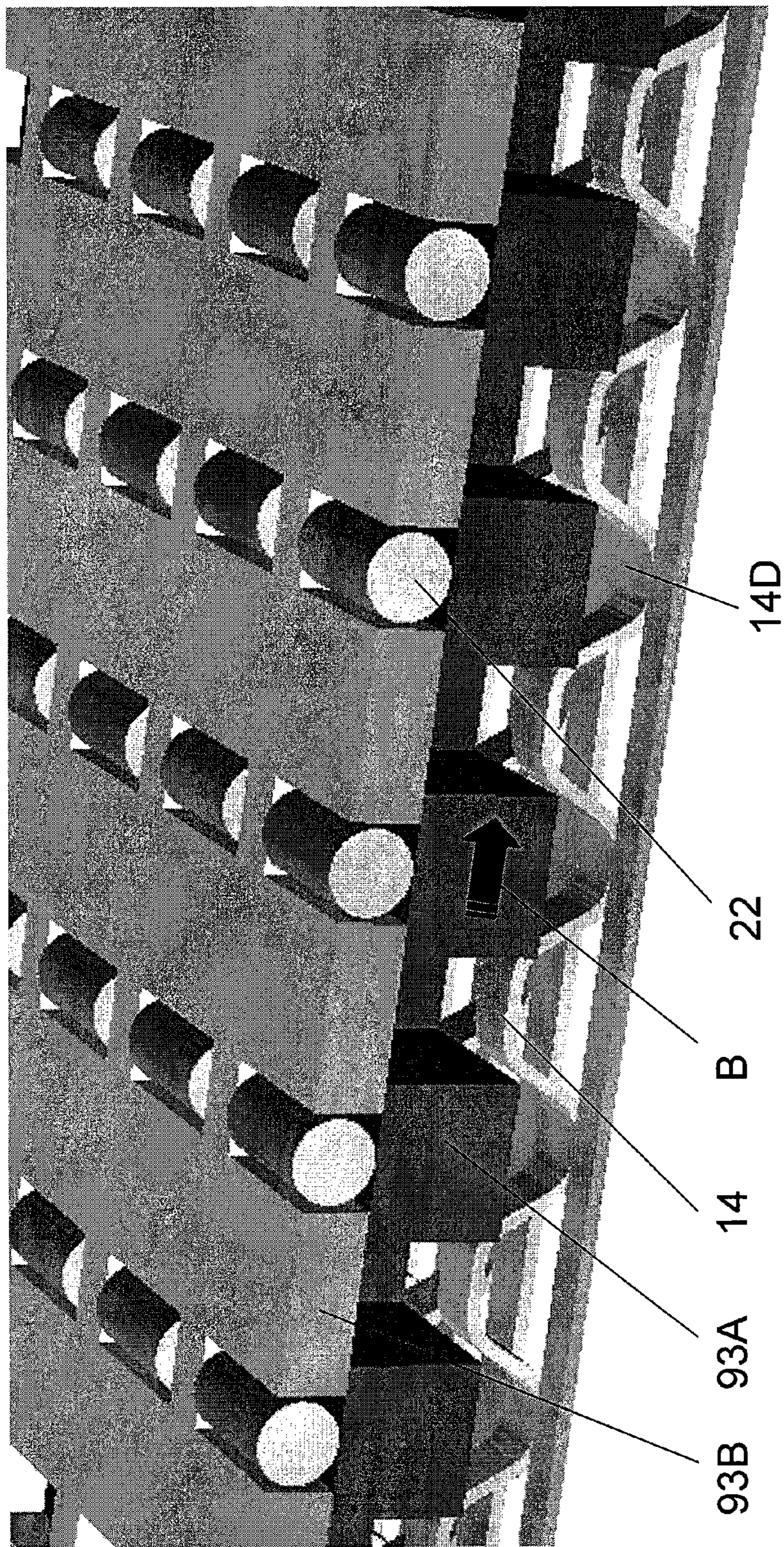

Fig. 10

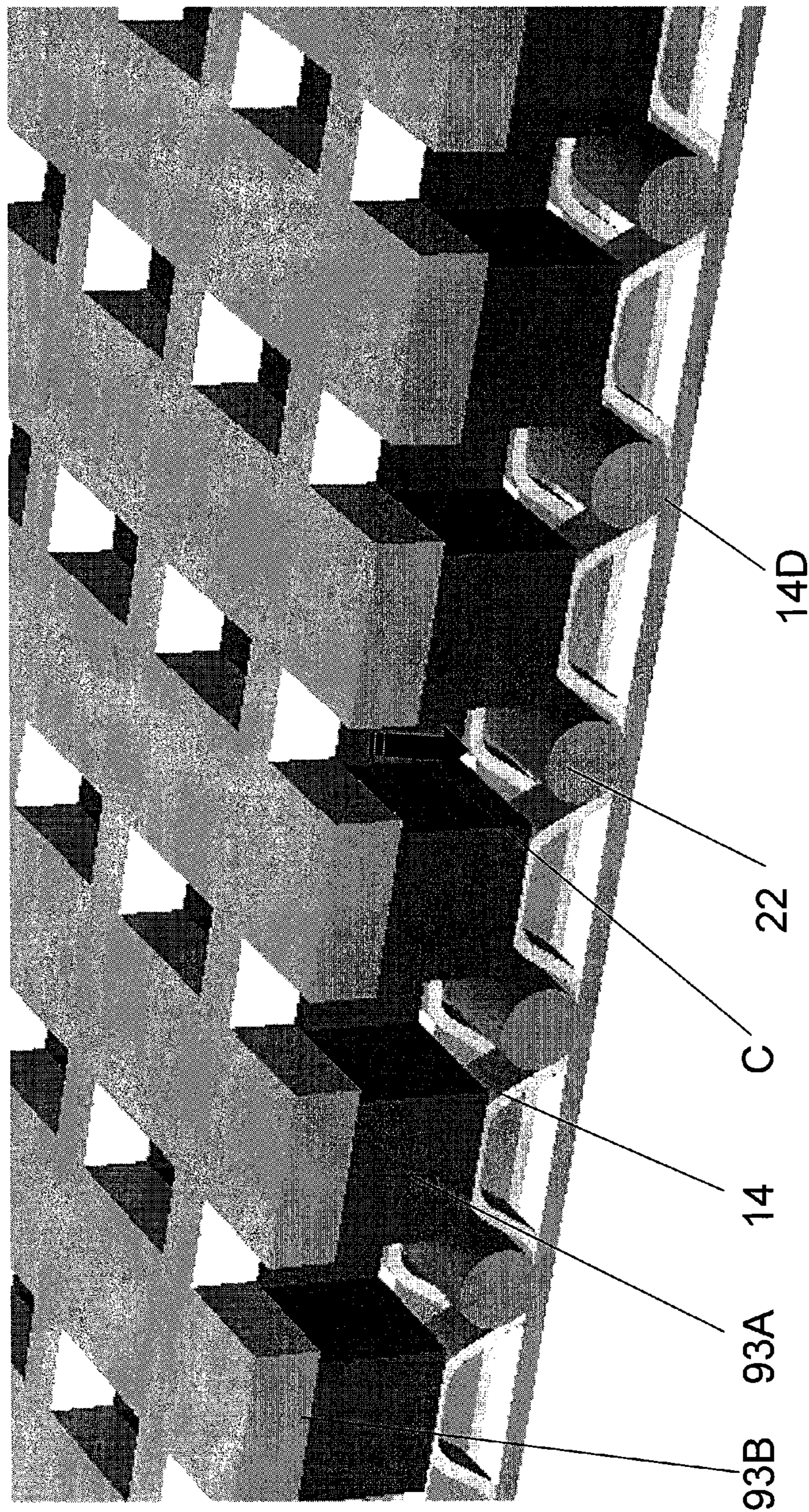

Fig. 11

1

**FUEL CELL CURRENT COLLECTOR WITH
LOADING MATERIAL DEPOSITED
THEREON AND METHOD OF MAKING
SAME**

CROSS-REFERENCE TO RELATED
APPLICATION

This application is a divisional of application Ser. No. 11/746,911, filed May 10, 2007 now U.S. Pat. No. 8,137,741, the entire disclosure of which is hereby incorporated by reference.

BACKGROUND OF THE INVENTION

This invention relates to fuel cells and, in particular, to fuel cell assemblies and components having loaded and retained catalyst therein and to apparatus and methods for performing such loading and retaining.

A fuel cell is a device which directly converts chemical energy stored in hydrocarbon fuel into electrical energy by means of an electrochemical reaction. Generally, a fuel cell comprises an anode and a cathode separated by an electrolyte, which serves to conduct electrically charged ions. In order to produce a useful power level, a number of individual fuel cells are stacked in series with an electrically conductive separator plate between each cell.

In internally reforming fuel cells, a reforming catalyst is placed within the fuel cell stack to allow direct use of hydrocarbon fuels such as methane, coal gas, etc. without the need for expensive and complex reforming equipment. In a reforming reaction, fuel cell produced water and heat are used by the reforming reaction, and the hydrocarbon fuel is internally reformed to produce hydrogen for fuel cell use. Thus, the necessary hydrogen fuel is produced by the reforming reaction, and since the reaction is endothermic, it can also be used advantageously to help cool the fuel cell stack.

Two different types of internal reforming have been developed for fuel cell assemblies. One type of internal reforming is indirect internal reforming, which is accomplished by placing the reforming catalyst in an isolated chamber within the stack and routing the reformed gas from this chamber into the anode compartment of the fuel cell. A second type of internal reforming is direct internal reforming. This type of internal reforming is accomplished by placing the reforming catalyst within the active anode compartment or fuel flow field, which provides the hydrogen produced by the reforming reaction directly to the anode.

A typical fuel cell anode compartment comprises a separator or bipolar plate for isolating fuel from the oxidant stream of the neighboring fuel cell, an anode electrode for providing electrochemical reaction sites, and an anode current collector often provided as a corrugated plate, for conducting electronic current from the anode electrode. The anode current collector is in contact with the anode electrode and also defines flow channels for the fuel gas. The reforming catalyst is placed in these flow channels to provide the direct internal reforming.

The reforming catalyst is usually available as compacted or solid particles having various solid shapes or forms such as tablet, pellet, rod, ring or sphere. However, due to the dimensions of the catalyst particles, difficulties have been encountered in trying to load the particles in the current collector channels. One difficulty is that the relatively small size of the catalyst particles makes them difficult to handle during assembly. This, in turn, makes the process of catalyst loading inefficient, and thus, unduly costly.

2

A second difficulty sometimes arises in achieving and maintaining a desired loading pattern of the catalyst because of the tendency of the catalyst particles to shift during the loading process and the fuel cell assembly process. The importance of the desired loading pattern stems in part from the desire to maintain a required heating profile in the fuel cell stack. This profile helps promote efficient and long term operation of the stack.

A manner of improving the efficiency and reliability of loading the catalyst particles in fuel cell components is thus always desirable. Additionally, the ability to better retain the loaded catalyst while concurrently enabling maximum operational efficiency is also a goal in the manufacturing process.

SUMMARY OF THE INVENTION

In accordance with the embodiment(s) of the invention disclosed hereinafter, an apparatus and associated method are provided in a system for accurately loading catalyst particles into fuel cell components. An apparatus and associated method are also provided in a system which uses a fixing agent for retaining the loaded catalyst and, if desired, other fuel cell components.

A particular system in use of the apparatus and method comprises a support for supporting a fuel cell component adapted to receive catalyst particles and a deposition assembly adapted to load the catalyst particles onto the fuel cell component. The system further optionally comprises a mechanism for applying a fixing agent to the fuel cell component and the loaded catalyst particles for retention of the catalyst particles.

In a further aspect of the invention, the fixing agent applied to the fuel cell component is further adapted to permit the fuel cell component to be held to another fuel component. It is also contemplated that a like fixing agent be used with additional fuel cell components so that these additional components, the another component and the catalyst loaded component, with the aid of the fixing agent, are held together so as to in facilitate handling and stacking of the components in the formation of a fuel cell stack.

In the embodiments disclosed, the fuel cell component is a corrugated anode current collector, the other component is a separator plate and the additional components are an anode, a cathode and a cathode current collector and the fixing agent is a double-sided adhesive medium.

It is contemplated that the aforementioned fixing agent comprises, optionally, a double-sided acrylic adhesive tape of the type currently manufactured by the 3M Company.

In one illustrative form of the invention, the deposition assembly includes individual deposition mechanisms each adapted to urge a catalyst particle delivered to the deposition mechanism onto the fuel cell component. The deposition mechanisms are arranged in a row across the width of the fuel cell component and are caused to be selectively operated based on the sensed position of the fuel cell component. As the fuel cell component is indexed, the sensed position causes an actuator assembly to selectively operate the deposition mechanisms and this continues until the fuel cell component is loaded. In this embodiment, each deposition mechanism optionally comprises a hydraulic or pneumatic cylinder or an electric actuator with a plunger and a gate assembly. The gate assembly holds the catalyst particle and prevents it from being delivered to the fuel cell component. Upon operation of the actuator assembly, the gate assembly is released and the hydraulic or pneumatic cylinder or electric actuator moves the plunger to urge the catalyst particle onto the fuel cell component.

In another illustrative embodiment, the deposition assembly includes a mask gate assembly having overlying first and second plates. The first plate has openings corresponding to the predetermined areas on the fuel cell component to receive catalyst and the second plate has openings corresponding to all the areas of the fuel cell component able to receive catalyst particles. The first plate is disposed over the fuel cell component and the second plate is disposed over the first plate so that its openings are misaligned with the openings of the first plate. The second plate is then loaded with catalyst particles which come to reside in the plate openings and are blocked from entering the openings in the first plate due to the misalignment.

The second plate is then shifted by the actuator assembly so that its openings then align with those in the first plate. Vibration motion being applied to the plates causes the catalysts in the aligned openings of the two plates to pass from the openings in the second plate through the aligned openings of the first plate and from these openings to the corresponding areas of the fuel cell component. The fuel component is thereby loaded with a predetermined pattern of catalyst defined by the first plate.

BRIEF DESCRIPTION OF THE DRAWINGS

The above and other features and aspects of the present invention will become more apparent upon reading the following detailed description in conjunction with the accompanying drawings, in which:

FIG. 1 shows a molten carbonate fuel cell with a first reforming catalyst member.

FIG. 1A shows a molten carbonate fuel cell with a second reforming catalyst member.

FIG. 2 shows a system for the placement of catalyst particles in the form of pellets onto a current collector associated with the anode electrode of a fuel cell assembly.

FIG. 3 shows the system of FIG. 2 and subsequent placement of a fixing agent to retain positioning of the loaded catalyst particles relative to the current collector

FIGS. 3A-3C show the details of the deposition mechanisms of the system of FIGS. 2 and 3 and the sequence of operation of these mechanisms.

FIG. 4 shows final placement of the catalyst members in a chosen pattern relative to the current collector.

FIG. 4A shows the second catalyst member as shown in FIG. 1A.

FIG. 5 shows, demonstrably, the process of using a fixing agent in adhering a current collector loaded with the catalyst particles to other components in the forming of a fuel cell assembly.

FIG. 6 shows an exploded view of the components of a fuel cell assembly joined together with a fixing agent.

FIG. 7 shows a vacuum press unit for compressing under heat the fuel cell assembly of FIG. 6.

FIG. 8 shows a further system for the placement of catalyst particles in the form of pellets onto a current collector.

FIG. 9 shows the mask gate assembly of the system of FIG. 8.

FIGS. 10 and 11 show an exploded view of a portion of the mask gate assembly of FIG. 9 with the mask gate closed and opened, respectively

DETAILED DESCRIPTION

Referring to FIGS. 1, 1A and 6, there is shown a fuel cell stack formed by stacking assemblies 10 one on the other with an electrolyte matrix 11 between adjacent assemblies. The

electrolyte matrix 11 is adapted hold an electrolyte such as, for example, a carbonate electrolyte. Each assembly 10 comprises an anode electrode 12 and an associated current collector 14, shown as having corrugations 14A. Each assembly 10 further comprises a bipolar separator 16 which separates the anode electrode 12 and current collector 14 from a cathode electrode 18 and its associated current collector 20, also shown as having corrugations 20A. The corrugations 14A of the anode current collector 14 define with the bipolar separator plate 16 and the anode electrode 12, first and second sets of fuel gas channels 14B and 14C. The anode current collector is further loaded with a plurality of catalyst particles 22 situated in the channels 14B and, in particular, in the areas 14D between and engaged by the legs of adjacent corrugations 14A. The catalyst particles 22 can take on various configurations. In FIG. 1, the catalyst particles 22 are shown as having a square cross-section and in FIG. 2 as having a circular cross-section. Other cross-section shapes such as hexagonal and "star" to improve the available surface area can also be used for the catalyst particles 22.

The catalyst particles 22 promote further reforming of the hydrocarbons in the fuel gas in the channels 14B to increase the hydrogen content of the gas. A portion of the further reformed gas in the channels 14B then passes into the channels 14C via openings in or discontinuities in the corrugations 14A as the gas continues traveling along the channels 14B. The further reformed gas thus combines with the fuel gas introduced directly into the channels 14C and the combined gas is thereby made available to participate in the electrochemical conversion reaction at the anode 12.

In order that the above-mentioned reforming reaction takes place efficiently in the fuel gas channels 14B and also in order to promote a desired heating profile for the fuel cell stack, it is desirable to load the anode current collector 14 with the catalyst particles 22 in a certain pattern and to retain that pattern. Accordingly, the following provides an advantageous way in which to achieve both the loading and retaining of the catalyst particles in a desired pattern.

Referring to FIGS. 2-3, there is shown schematically a system 24 for the loading and retaining of the catalyst particles 22 on the anode current collector 14. The catalyst particles 22, optionally provided in the form of pellets as shown in FIG. 2, are fed from a hopper 26 situated in the vicinity of the current collector 14. The current collector 14 rests on an X-Y movable support or table 51 capable of moving in the X and Y directions. Looking at FIGS. 2 and 3, the hopper 26 is provided with a hopper feed 28 containing a plurality of feed channels 28A arranged in a row so as to span the width (X direction) of the current collector 14. The feed channels 28A lead to a deposition assembly 29 comprised of a row or line of deposition mechanisms 30 also situated to span the width of the current collector 14.

Each of the deposition mechanisms 30 is fed by one of the feed channels 28A and is further aligned with one of the areas 14D between adjacent legs of the corrugations 14A spanning the width of the current collector. By selecting the number of deposition mechanisms 30 to be equal to the number of spaces 14D, each space 14D across the width of the collector plate 14 is able to be fed a catalyst particle 22 by its respective deposition mechanism. Moreover, as shown in FIG. 3 and as above-mentioned, the corrugations 14A are discontinuous in the length direction (Y direction) of the current collector so that they form a plurality of spaced rows 36. Accordingly by bringing each row 36 of corrugations in line with the row of deposition mechanisms 30, the spaces 14D in each row are able to be fed catalyst particles 22 by the associated deposition mechanisms 30.

5

More particularly, the hopper 26, as a result of vibratory motion imparted thereto, delivers a catalyst particle 22 to each of the feed channels 28A of the hopper feed 28. Each feed channel, in turn, brings a catalyst particle 22 to its respective deposition mechanism 30. In the case shown, as can be seen in more detail in FIGS. 3A-3C, each deposition mechanism 30 defines a chamber 30A in which the fed catalyst particle 22 settles and is held by a gate assembly shown optionally as a spring loaded ball assembly 30B. Other forms of the gate assembly might be an actuator or cylinder assembly. Above the gate assembly, the deposition mechanism 30 includes a hydraulic or pneumatic cylinder or electric actuator 30C equipped with a plunger 35 which contacts the catalyst particle.

Actuation of a deposition mechanism 30 then results in the sequence of operations in FIGS. 3A-3C. The assembly 30B is first retracted allowing the passage of the catalyst particle 22 downward through the chamber 30A. The hydraulic or pneumatic cylinder or electric actuator 30C then operates causing its plunger to force the catalyst particle 22 downward into the area 14D between the feet of the adjacent corrugations 14. At this time, the plunger also blocks entry of further catalyst particles 22 into the chamber. This blockage can also be accomplished by a clamp bar or similar type of assembly that is brought into the path of the further catalyst particles in conjunction with the plunger being moved downward. The hydraulic or pneumatic cylinder or electric actuator cylinder 30C then completes its stroke forcing the catalyst particle 22 to be held between the corrugations.

Once this operation completes, the hydraulic or pneumatic cylinder or electric actuator 30C retracts the plunger and the spring loaded ball assembly 30B returns to its original position. This allows the next catalyst particle 22 from the feed chamber 28A to be delivered to and held in the chamber 30A of the deposition mechanism 30 for subsequent supply to the current collector 14.

Whether a particular deposition mechanism 30 in the deposition assembly is actuated is determined by an actuating assembly in the form of a programmed controller 38. The controller also controls the operation of the other components of the system 24 including the X-Y table or support 51.

Indexing of the table 51 under the control of the programmed controller 38 successively brings each of the rows 36 of corrugations 14A into line with the row of deposition mechanisms 30 which in the present case remain stationary. A sensor 40 acts as to indicate to the programmed controller 38 that a row 36 of corrugations 32 (see, FIG. 4) has now been brought into line with the row of mechanisms 30 of the deposition assembly 29. A simple counting mechanism in the controller, counts the rows, so that the programmed controller can identify a particular row. The controller 38 then based on a predetermined stored catalyst pattern which correlates row numbers and associated areas 14D to receive catalyst particles 22, actuates the particular depositions mechanisms 30 associated with the catalyst receiving areas. This results in deposition of catalyst particles 22 by the mechanisms 30 in the particular row in accordance with the predetermined pattern.

Continued indexing of the table 51 in the Y direction and actuation of the deposition mechanisms 30 by the controller 38 thus results in the deposition of the catalysts particles 22 into all the rows of the corrugations of the collector 14 in accordance with the predetermined catalyst pattern. It is to be understood that the controller 38 can be programmed to obtain any desired predetermined pattern or to change the predetermined pattern for the catalyst deposition. Accordingly, the deposition of catalyst particles in the current col-

6

lector 14 can be made so as to achieve a predetermined pattern for heat management throughout the fuel cell stack to realize a maximum energy yield.

With continued reference to FIGS. 2-3, there is also provided in the system 24, a fixing agent 42 for retaining the placement of each of the catalyst particles 22 within their respective areas 14D of the corrugations 14A. The fixing agent 42 is carried on a supply roller 61 and is, optionally, in the form of a dual-sided medium comprising double sided acrylic tape. The tape comprises an exposed adhesive side 43 and a covered adhesive side 45 protected by a backing 47 (see, FIG. 5).

In use, once the catalyst particles 22 are in position, application of the tape 42 on the supply roller 61 occurs by use of the press roller 62 which guides and presses the tape 42 on the catalyst members 22 and corrugations 14A in a manner well understood by one of ordinary skill in the art. Such application enables sealing of the catalyst particles 22 against the respective legs of the corrugations 14A of the collector 14. This occurs, as will be understood by one of ordinary skill in the art, since the side 43 is urged against the catalyst particles and corrugations 14A by the press roller 62 while the side 47 is free from contact therewith.

As shown in FIG. 3 by the cutout portion thereof, the resultant placement of the catalyst particles 22 is retained, as is represented by FIG. 4. It is to be understood that the fixing agent of the present invention may also be arranged for use with an alternatively shaped catalyst member 46, optionally provided as an extruded material dimensioned substantially cylindrically, as shown in FIG. 4A. With the option of using an alternative member 46 such as that shown and corresponding to member 23 of FIG. 1A, any one such member 46 may be provided in a dimension extending substantially the length of the collector plate 14.

With reference to FIGS. 5-6, the process of assembling the fuel cell assembly 10 using the fixing agent 42 is described. Once application of the adhesive side 43 of the tape 42 occurs such that the uncovered adhesive attaches atop the catalyst particles 22 and portions of the collector plate 14, the backing 47 covering the opposed side 45 of the tape 42 is available for removal therefrom. This removal is shown as indicated by arrow "A" in FIG. 5.

Referring to FIGS. 6, 1 and 1A, there is shown, diagrammatically, the assembly shown in FIGS. 1 and 1A. Such assembly comprises the use of the fixing agent 42 not only in retention of the catalyst particles 22 to the collector plate 14, but also in retention of the electrodes 12 and 18 and their associated collector plates 14 and 20 to the bipolar separator plate 16. As such, it may be seen that the anode electrode 12 is assembled to its respective current collector plate 14 by strips of the tape 42 described hereinabove and situated on the top side of the plate. The underside 48 of the collector plate 14 housing the catalyst members 22 is covered with the exposed adhesive side 43 of the tape 42. The backing 47, as shown in FIG. 5, is then removed to enable adherence to, and thus construction with, the bipolar separator plate 16. Accordingly, the anode half of the fuel cell assembly 10 is then achieved.

Construction of the cathode half of the fuel cell assembly 10 begins by attaching the underside 54 of the cathode current collector 20 to the underside 56 of the bipolar separator plate 16 via the tape strips 42 on the underside of the bipolar plate after removal of the backing 47 of these strips exposing the adhesive layer 43. Thereafter, with the exposed adhesive side 43 of the tape 42 covering the surface 58 of the cathode current collector 20, the backing 47 thereof is ready to be

removed. Once removed, the cathode electrode **18** may be adhered thereto to complete assembly of the cathode half of the fuel cell assembly **10**.

In order to ensure that the components of the assembly **10** remain in tact, the assembly **10** can be subjected to pressure and heat in order to enhance the retention power of the tape **42**. FIG. **7** shows a vacuum press unit **71** which can be used of this purpose. The unit **71** includes upper and lower platens **72** and **73** supported, respectively, on a top cover **74** pivotably attached to a base assembly **75**. The top cover **74** carries a vacuum sealing gasket **76** which borders the periphery of the upper platen **72**. When the cover **74** is lowered by pivoting, the upper and lower platens **72** and **73** are brought together by locating pins **77** on the base assembly **75** and corresponding locating holes **78** in the cover to form a sealed vacuum chamber for receiving the assembled fuel cell assembly **10**.

A heated air inflow unit **79** is then turned on to draw-in outside air and to heat the air. The heated air is then delivered to the sealed vacuum chamber through a plenum along the side **75A** of the base assembly. Air delivery ports **81** convey the heated air from the plenum to the sealed vacuum chamber between the platens when the platens are brought together with the assembly **10** secured between them.

The heated air heats the assembly **10** and passes from the vacuum chamber via air exit ports **82** on the other side **75B** of the base assembly **75** to a plenum on this side of the assembly. After assembly **10** reaches a desired temperature, the heated air unit **79** closes or shuts off and a blower or fan **83** is turned on. This allows the blower or fan **83** to draw vacuum from the base assembly **75** with the assembly **10** in it via the air exit ports **82** and the plenum on the side **75B** of the base assembly **75**. As a result, a thermo-vacuum pressing of the assembly **10** is carried out. After a predetermined time, the pressing of the assembly **10** is complete and the fan **83** is turned off. The platens **72** and **73** are then separated by pivoting the top cover **74** upward, thereby allowing removal of the assembly **10**.

FIGS. **8-11** show a further assembly for deposition of the catalyst particles into preselected of the areas **14D** of the current collector **14**. As shown the system comprises a mass block or base member **91** which supports a vibratory block **92**. A mask gate assembly **93** is supported by the vibratory block **92** against the anode current collector **14** which is to be loaded with catalyst particles. A hopper **94** holds catalyst particles in the form of pellets and these are fed to the mask gate assembly **93**.

The mask gate assembly is shown in more detail in FIGS. **9-11** and comprises clamp bars **93C**, **93D** and pneumatic clamps **93E** which clamp overlying gate and mask plates **93A** and **93B** together and to the vibratory block over the current collector **14**. As shown, the mask plate **93B** lies above the gate plate **93A** and the gate plate **93A** faces the current collector. Spring loaded pins **93F** provide a downward force across the surface of the mask plate **93B**, while still permitting catalyst pellets to have access to the openings in the mask plate as discussed further hereinbelow. The clamping of the plates is such that the gate plate **93A** can be shifted or translated laterally (in the direction of the arrow **B**) relative to the mask plate **93B** via a mechanical force applied by an operator either directly or via an actuator.

The mask plate **93B** has through openings equal in number and positioned to coincide with the pre-selected areas **14D** between the legs or feet of adjacent corrugations of the collector which are to receive catalyst pellets in accordance with the desired pattern. The gate plate **93A**, in turn, also has through openings. These openings, however, are equal in number and positioned to coincide with all the areas **14D** of the collector.

As shown in FIG. **10**, the mask gate assembly **93** is clamped to the vibratory block **92** over the current collector so that the through openings in the gate plate **93A** are misaligned with the areas **14D** of the current collector while the through openings of the mask plate **93B** are aligned with these openings. Solid areas of the gate plate **93A** thus block movement from the through openings of the mask plate **93B** to the areas **14D** of the current collector. In this closed position of the gate assembly **93**, vibration is used to move catalyst pellets from the hopper **94** so that they distribute along the length of the mask plate **93B** and deposit in the through openings of the mask plate.

The mask plate **93B** is designed such that only one catalyst pellet can reside in each of its openings. The catalyst pellets also cannot sit on top of one another due to the mask plate thickness being less than the pellet diameter. This creates channels for the catalyst pellets to travel along until they reach an empty opening in the mask plate. Once the openings in the mask plate **93B** are all filled, the gate plate **93A** is shifted laterally as shown by the arrow **B** in FIG. **10** to bring the mask gate assembly **93** to its open position as shown in FIG. **11**.

In this position, due to the shifting of the gate plate **93A**, the through openings in the gate plate now align with the areas **14D** of the current collector and also with the through openings in the mask plate **93B**. The catalyst pellets thus fall in the direction of the arrow **C** from the openings in the mask plate **93B** through the corresponding openings in the gate plate **93A** into the underlying areas **14D** of the current collector. The current collector **14** thus becomes loaded with catalyst pellets in accordance with the desired predetermined pattern.

Moreover, the vibratory motion imparted to the current collector by the block **92** causes the catalyst pellets to orient themselves in the areas or pockets **14D** of the current collector in such a way as to not protrude above the height of the legs defining the areas. This allows for further processing of the catalyst loaded current collector as by application of an adhesive fixing agent to hold the catalyst pellets in the current collector as discussed above.

To aid in securing the catalyst pellets in the areas **14D** of the current collector, the vibratory block **92** is adapted to be subjected to a vacuum which secures the current collector to the block via an adhesive membrane on the current collector. This provides an intimate contact between the collector and a very smooth, even transmission of vibration. As a result, the catalyst pellets are moved into and settle into the areas **14D** so as to not protrude from the current collector as above-described.

In all cases it is to be understood that the above-described subject matter is merely illustrative of the many possible specific embodiments, which represent applications of the present invention. Numerous and varied other arrangements can be readily devised in accordance with the principles of the present invention, without departing from the spirit and scope of the invention. In particular, while the invention has been illustrated in terms of loading an anode current collector with catalyst particles, it is evident that the principles of the invention extend to loading of other fuel cell components defining or forming the anode flow field or fuel flow field of a fuel cell. Loading of a bipolar separator plate with catalyst particles might be one example.

What is claimed is:

1. A method of fabricating a fuel cell component for use with or as part of a fuel cell in a fuel cell stack, the fuel cell component comprising a corrugated current collector and the method comprising:

depositing loading material onto the corrugated current collector in predefined areas defined by legs of corruga-

9

tions of the corrugated current collector, the loading material comprising one of an extruded catalyst and catalyst pellets;

maintaining positioning of the loading material relative to the predefined areas of the corrugated current collector by applying a tape fixing agent to the corrugated current collector and sealing the loading material against respective legs of the corrugations of the corrugated current collector, wherein the tape fixing agent is an adhesive tape.

2. The method in accordance with claim 1, wherein: said adhesive tape is a double-sided adhesive tape.

3. The method in accordance with claim 2, further comprising:

joining another fuel cell component to said corrugated current collector via said double-sided adhesive tape.

4. The method in accordance with claim 3, further comprising:

applying additional double-sided adhesive tape to said corrugated current collector and applying double-sided adhesive tape to said another fuel cell component and one or more of additional fuel cell components and joining said corrugated current collector, said another fuel cell component and said additional fuel cell components together via said double-sided tape.

5. The method in accordance with claim 4, wherein: said corrugated current collector is an anode current collector, said another fuel cell component is a separator plate and said additional fuel cell components are an anode, a cathode current collector and a cathode.

6. The method in accordance with claim 4, further comprising:

applying heat and pressure to said fuel cell components and said double-sided adhesive tape to facilitate said double-sided adhesive tape holding said fuel cell components together.

7. The method in accordance with claim 1, wherein: said corrugated current collector is one or more of an anode current collector, a component used in forming the fuel flow field of a fuel cell and a component used in forming the anode flow field of a fuel cell.

8. The method of applicant's claim 1, wherein the corrugated current collector includes a central area and a peripheral area and wherein the predefined areas of the corrugated current collector into which the loading material is deposited include at least one or more areas in the central area of the corrugated current collector.

9. The method of claim 1, wherein the fuel cell stack is a high temperature fuel cell stack and the fuel cell component is a high temperature fuel cell component.

10. An assembly for use with or as part of a fuel cell stack, the assembly comprising:

a fuel cell component comprising a corrugated current collector;

a loading material deposited in predefined areas defined by legs of corrugations of the corrugated current collector, the loading material comprising one of an extruded catalyst and catalyst pellets; and

a tape fixing agent comprising an adhesive tape applied to the corrugated current collector, wherein the tape fixing

10

agent maintains positioning of the loading material relative to the predefined areas of the current collector and seals the loading material against respective legs of the corrugations of the corrugated current collector.

11. The assembly in accordance with claim 10, wherein: the tape fixing agent comprises a double-sided adhesive tape.

12. The assembly in accordance with claim 11, wherein: the double-sided adhesive tape is an acrylic tape.

13. The assembly in accordance with claim 10, further comprising:

a further fuel cell component; and

a further tape fixing agent cooperating with said corrugated current collector and said further fuel cell component for retaining said corrugated current collector and said further fuel cell component together.

14. The assembly in accordance with claim 13, further comprising:

additional fuel cell components:

said tape fixing agent cooperating with one of said additional fuel cell components for retaining said corrugated current collector and said one of said additional fuel cell components together; and

additional tape fixing agents cooperating with the other of said additional fuel cell components for retaining said additional fuel cell components together.

15. The assembly in accordance with claim 14, wherein: heat and pressure have been applied to said tape fixing agents and said fuel cell components to facilitate said tape fixing agents retaining said fuel cell components together.

16. The assembly in accordance with claim 14, wherein: the tape fixing agent, further tape fixing agent and additional tape fixing agents each comprise a double-sided adhesive tape.

17. The assembly in accordance with claim 16, wherein: said corrugated current collector is an anode current collector;

said further fuel cell component is an anode electrode;

said additional fuel cell components comprise a separator plate, a cathode current collector and a cathode; and

said further tape fixing agent retains the anode current collector to the anode, said tape fixing agent retains the anode current collector to the separator plate, one of said additional tape fixing agents retains the separator plate to the cathode current collector, and another of said additional tape fixing agents retains the cathode current collector to the cathode.

18. The assembly of claim 10, wherein the corrugated current collector includes a central area and a peripheral area and wherein the predefined areas of the corrugated current collector into which the loading material is deposited include at least one or more areas in the central area of the corrugated current collector.

19. The assembly of claim 10, wherein the fuel cell stack is a high temperature fuel cell stack and the fuel cell component is a high temperature fuel cell component.

* * * * *