



US008781327B2

(12) **United States Patent**
Shen et al.

(10) **Patent No.:** **US 8,781,327 B2**
(45) **Date of Patent:** **Jul. 15, 2014**

(54) **USE OF MULTIPLE SHARED WAVELENGTH LOCKERS TO STABILIZE TRANSPONDERS IN A WAVELENGTH DIVISION MULTIPLEXING (WDM) NETWORK**

6,233,261 B1 * 5/2001 Mesh et al. 372/29.012
6,240,109 B1 * 5/2001 Shieh 372/18
6,556,328 B1 * 4/2003 Tanaka 398/192

(Continued)

(75) Inventors: **Xiao A. Shen**, San Bruno, CA (US);
Hongbing Lei, Sunnyvale, CA (US); **Yu Sheng Bai**, Los Altos Hills, CA (US)

FOREIGN PATENT DOCUMENTS

CN 101057425 A 10/2007
CN 101674135 A 3/2010
CN 101729184 A 6/2010
EP 1855396 A1 11/2007

(73) Assignee: **Futurewei Technologies, Inc.**, Plano, TX (US)

OTHER PUBLICATIONS

(*) Notice: Subject to any disclaimer, the term of this patent is extended or adjusted under 35 U.S.C. 154(b) by 321 days.

ITU-T, "Series G: Transmission Systems and Media, Digital Systems and Networks, Digital Sections and Digital Line System-Optical line Systems for Local and Access Networks, Gigabit-Capable Passive optical Networks (GPON): General Characteristics," G.984.1, Mar. 2008, 43 pages.

(Continued)

(21) Appl. No.: **13/177,771**

(22) Filed: **Jul. 7, 2011**

(65) **Prior Publication Data**

US 2012/0008955 A1 Jan. 12, 2012

Related U.S. Application Data

(60) Provisional application No. 61/362,792, filed on Jul. 9, 2010.

(51) **Int. Cl.**

H04J 14/02 (2006.01)
H04B 10/04 (2006.01)
H04B 10/24 (2006.01)

(52) **U.S. Cl.**

USPC **398/79**; 398/196; 398/195; 398/192;
398/41; 398/42; 398/43

(58) **Field of Classification Search**

USPC 398/41-43, 79, 196, 195, 192
See application file for complete search history.

(56) **References Cited**

U.S. PATENT DOCUMENTS

5,825,792 A 10/1998 Villeneuve et al.
6,118,562 A * 9/2000 Lee et al. 398/1

Primary Examiner — Oommen Jacob

(74) Attorney, Agent, or Firm — Conley Rose, P.C.; Grant Rodolph; Jonathan K. Polk

(57) **ABSTRACT**

An apparatus comprising at least one processor configured to receive a wavelength-division-multiplexed (WDM) signal from a remote node, wherein the WDM signal comprises a first channel carrying a first remotely generated signal, a second channel carrying a second remotely generated signal, and a third channel, adapt the WDM signal into a composite WDM signal by: dropping the first remotely generated signal from the first channel; adding a first locally generated signal to the first channel; and adding a second locally generated signal to the third channel, and provide wavelength locking to the first locally generated signal and the second locally generated signal without providing wavelength locking to the second remotely generated signal.

19 Claims, 9 Drawing Sheets

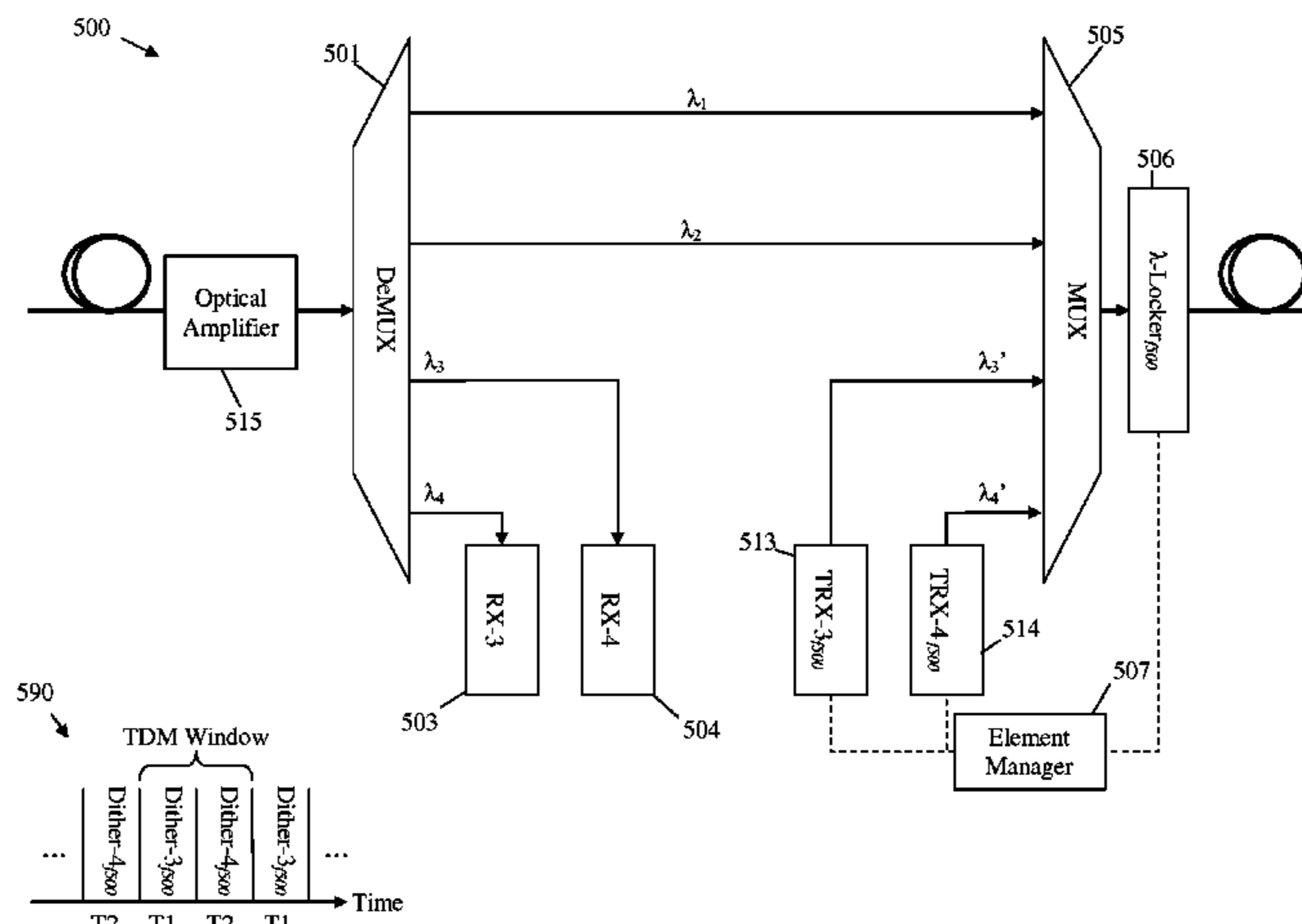

(56)

References Cited

U.S. PATENT DOCUMENTS

6,647,209 B1 * 11/2003 Boord et al. 398/84
 6,862,303 B2 * 3/2005 Kim et al. 372/32
 8,218,964 B2 * 7/2012 Tanzi et al. 398/1
 2002/0048063 A1 * 4/2002 Jung et al. 359/124
 2002/0186434 A1 * 12/2002 Roorda et al. 359/128
 2003/0007209 A1 * 1/2003 Liu et al. 359/127
 2004/0109685 A1 * 6/2004 Wan et al. 398/41
 2006/0045532 A1 * 3/2006 Yano 398/147
 2007/0172240 A1 * 7/2007 Terai et al. 398/83
 2007/0280700 A1 * 12/2007 Remedios et al. 398/183
 2008/0080865 A1 * 4/2008 Muro et al. 398/83
 2008/0089692 A1 4/2008 Sorin et al.
 2009/0074418 A1 * 3/2009 Levy et al. 398/83
 2009/0148166 A1 * 6/2009 Akiyama et al. 398/83
 2009/0196612 A1 8/2009 Lee et al.
 2009/0232493 A1 * 9/2009 Tu 398/17
 2010/0284687 A1 * 11/2010 Tanzi et al. 398/1

2011/0085794 A1 4/2011 Lei et al.
 2011/0158651 A1 6/2011 Tang et al.
 2011/0200334 A1 8/2011 Wu et al.

OTHER PUBLICATIONS

ITU-T, "Series G: Transmission Systems and Media, Digital Systems and Networks, Digital Sections and Digital Line System-Optical line Systems for Local and Access Networks, Gigabit-Capable Passive Optical networks (GPON): Physical Media Dependent (PMD) Layer Specification," G. 984.2, Mar. 2003, 38 pages.
 Hyunjae Lee, G. Y. Lyu, S. Y. Park, and J. H. Lee, "Multichannel Wavelength Locking Using Transmission Peaks of an AWG for Multichannel Optical Transmission Systems," IEEE Photon. Technology Letters, vol. 10, pp. 276-278, 1998.
 Foreign Communication From a Counterpart Application, PCT Application PCT/CN2011/077020, International Search Report, dated Oct. 20, 2011, 3 pages.

* cited by examiner

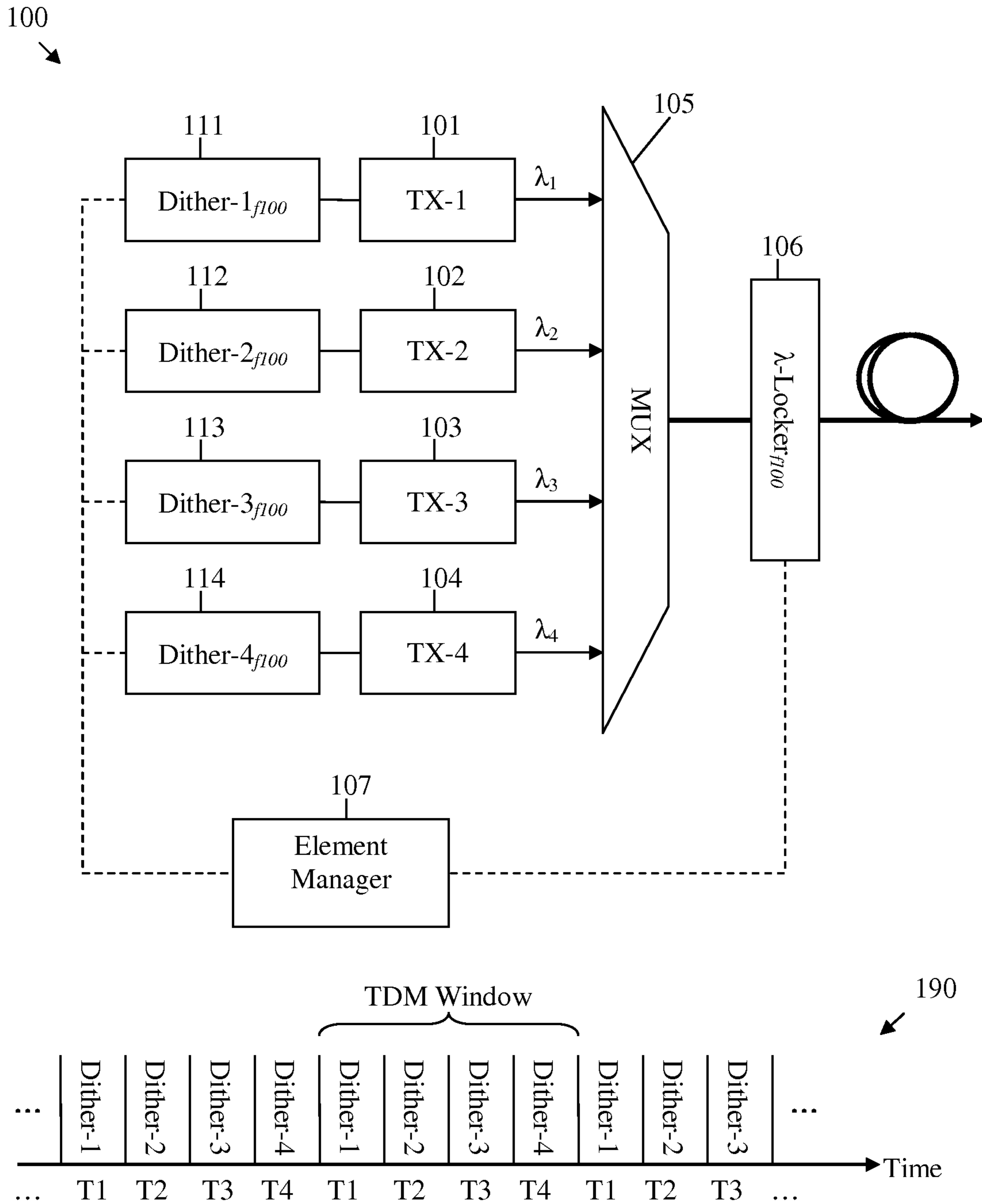

FIG. 1

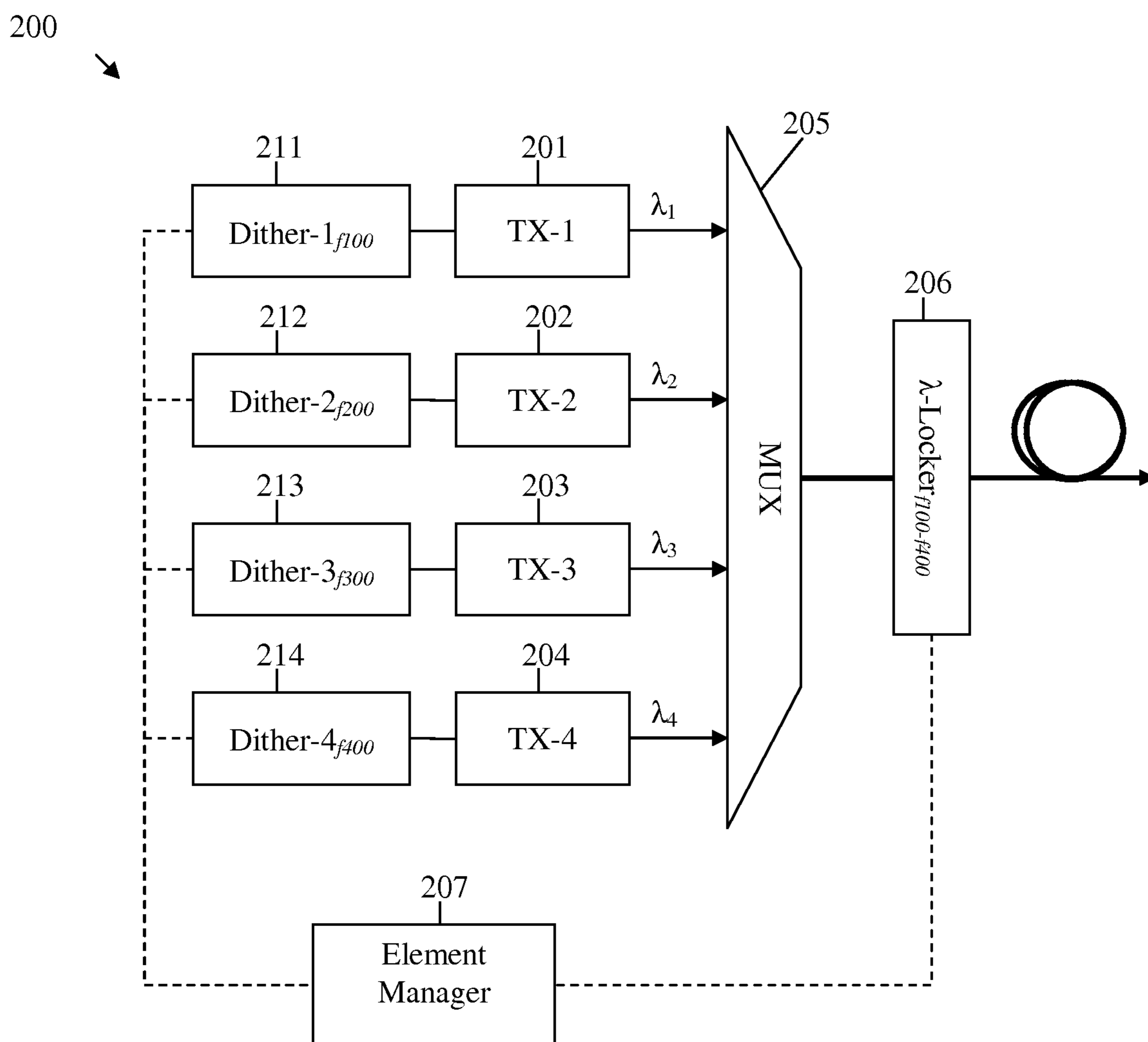

FIG. 2

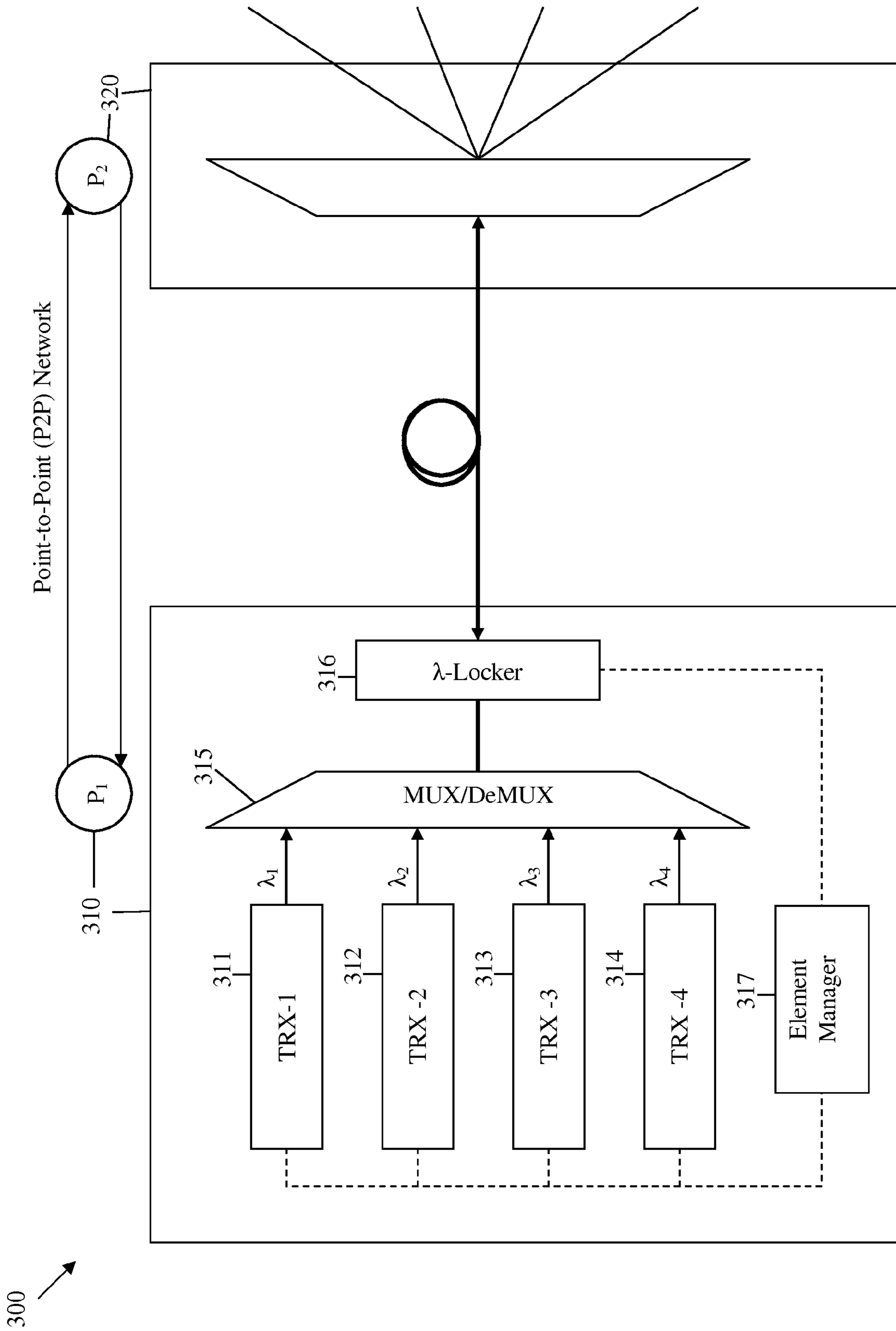

FIG. 3

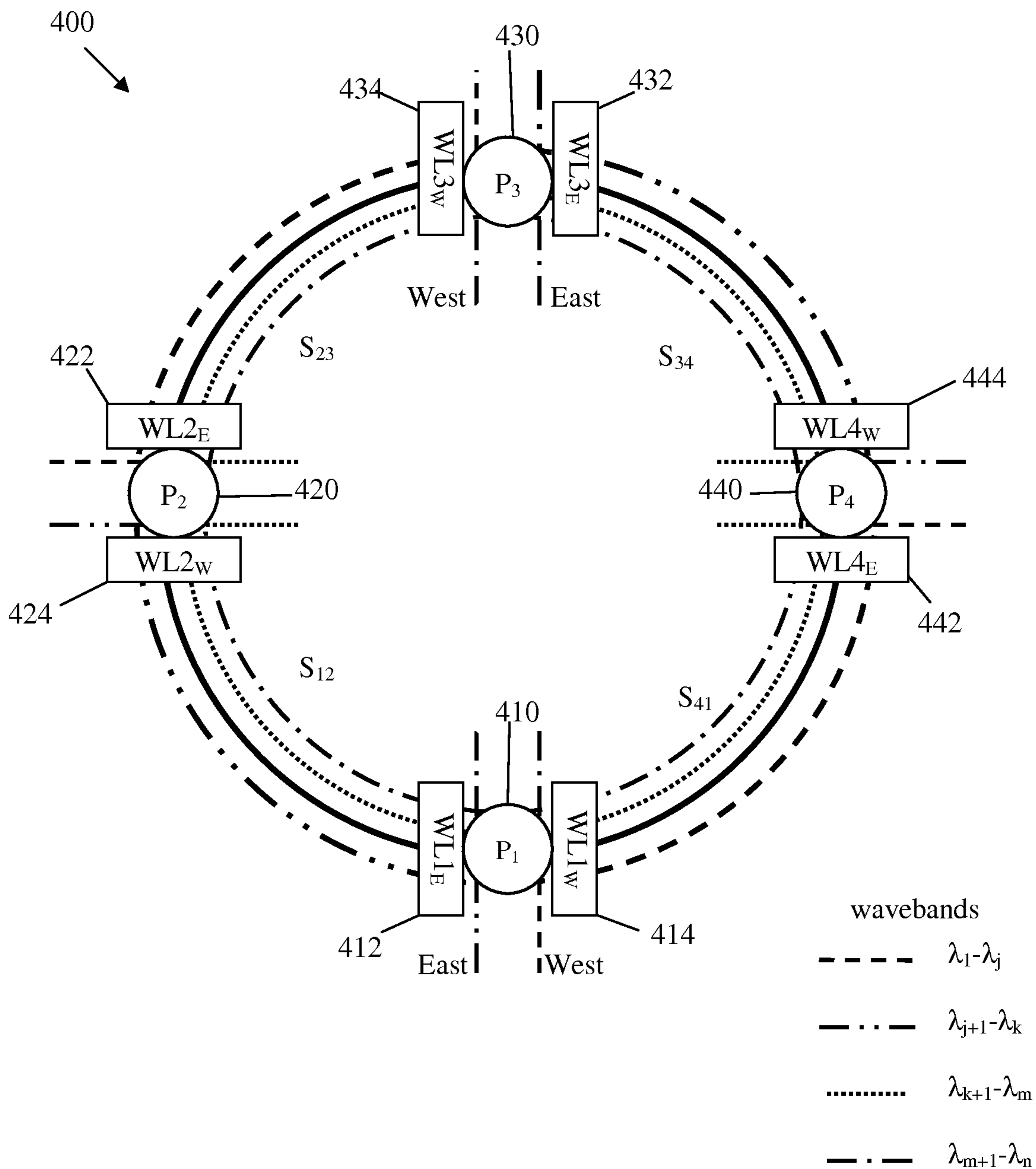

FIG. 4

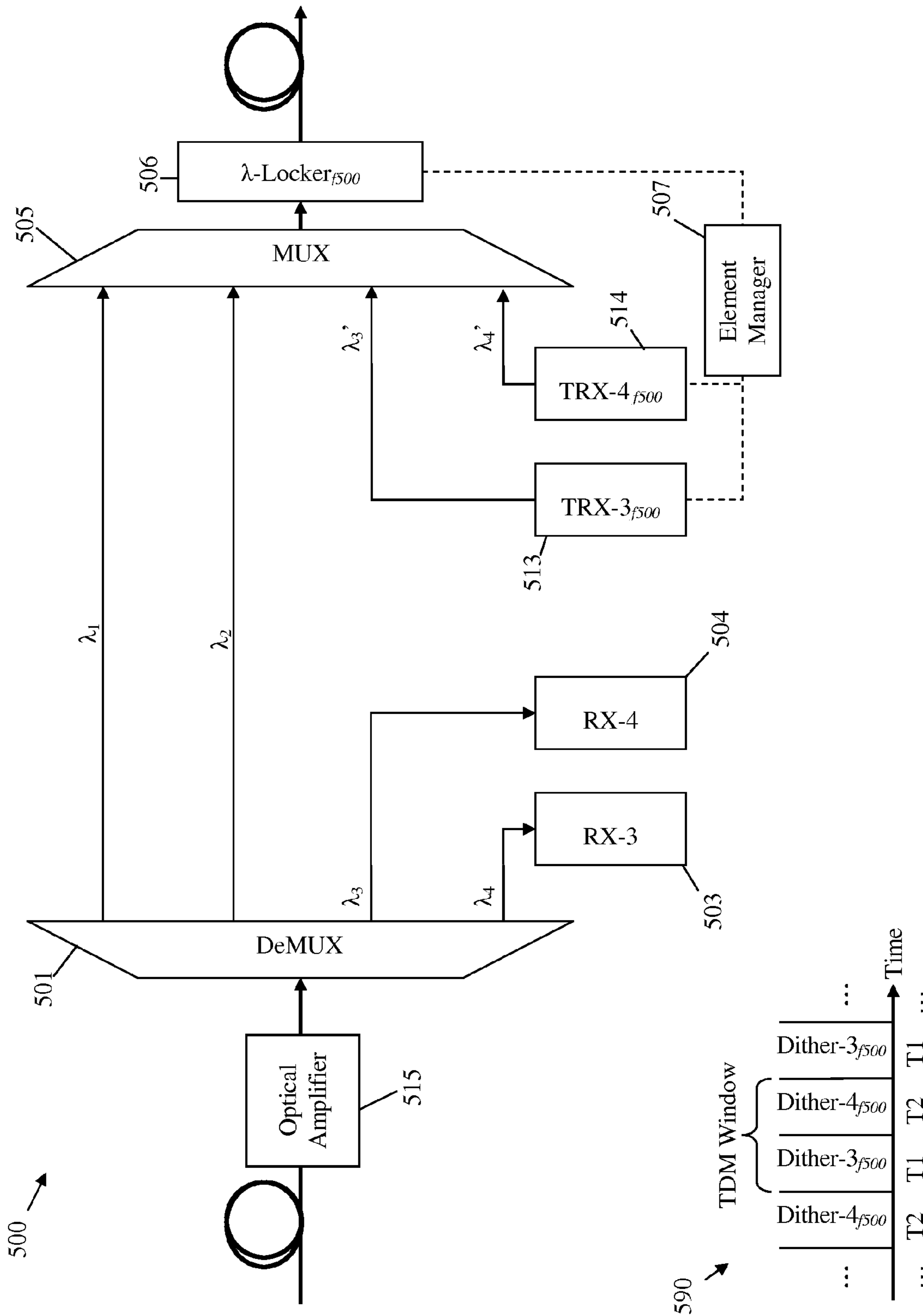

FIG. 5

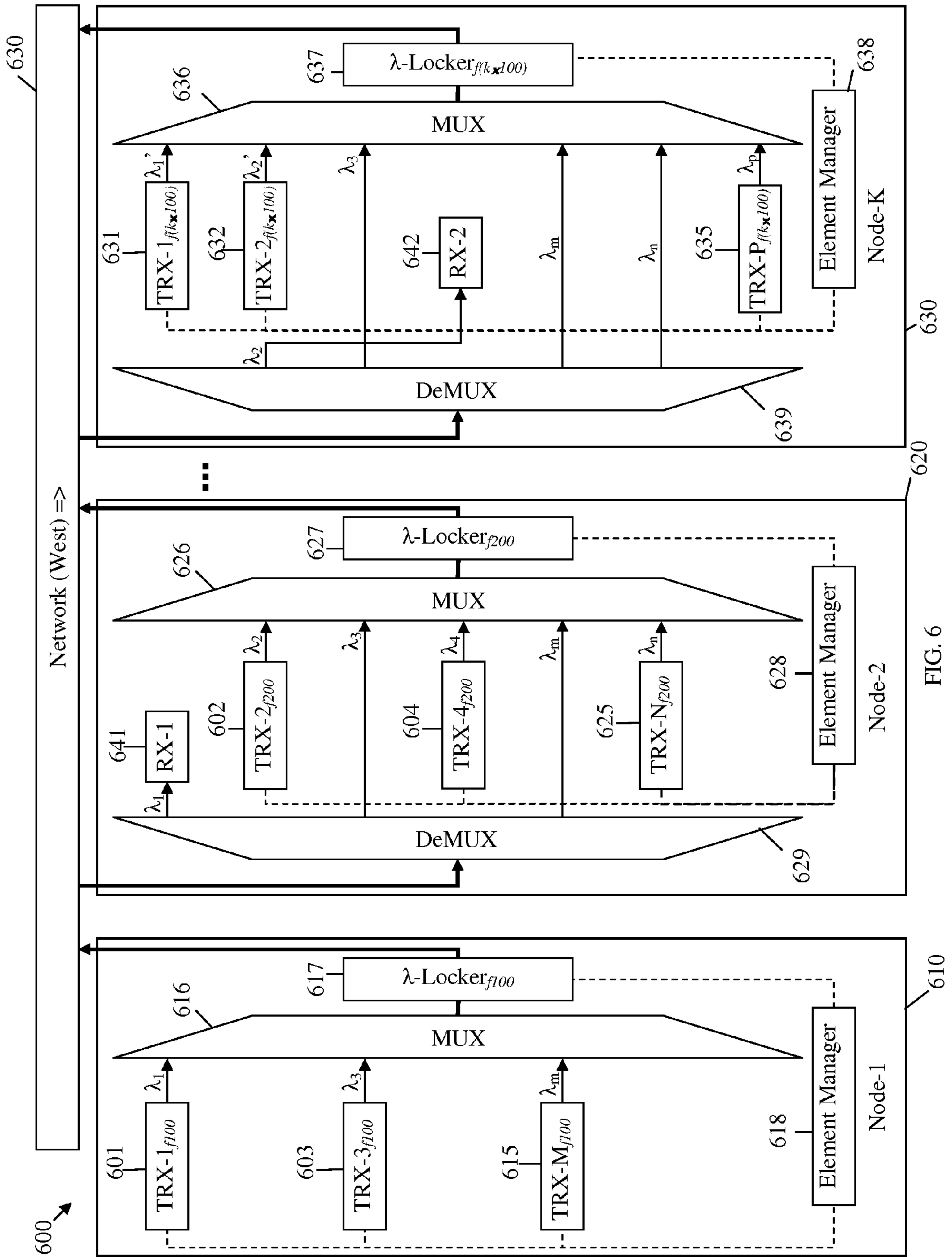

FIG. 6

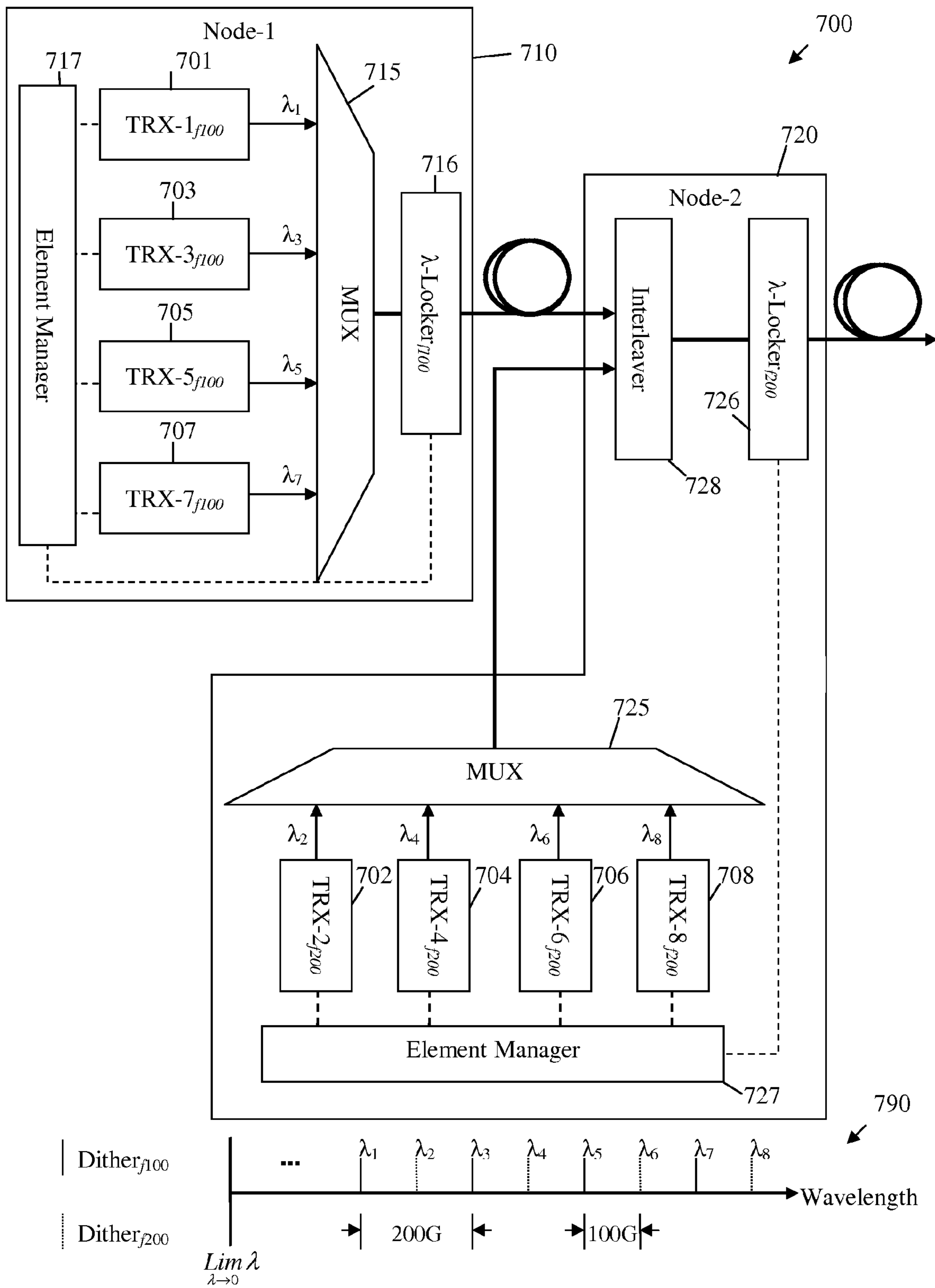

FIG. 7

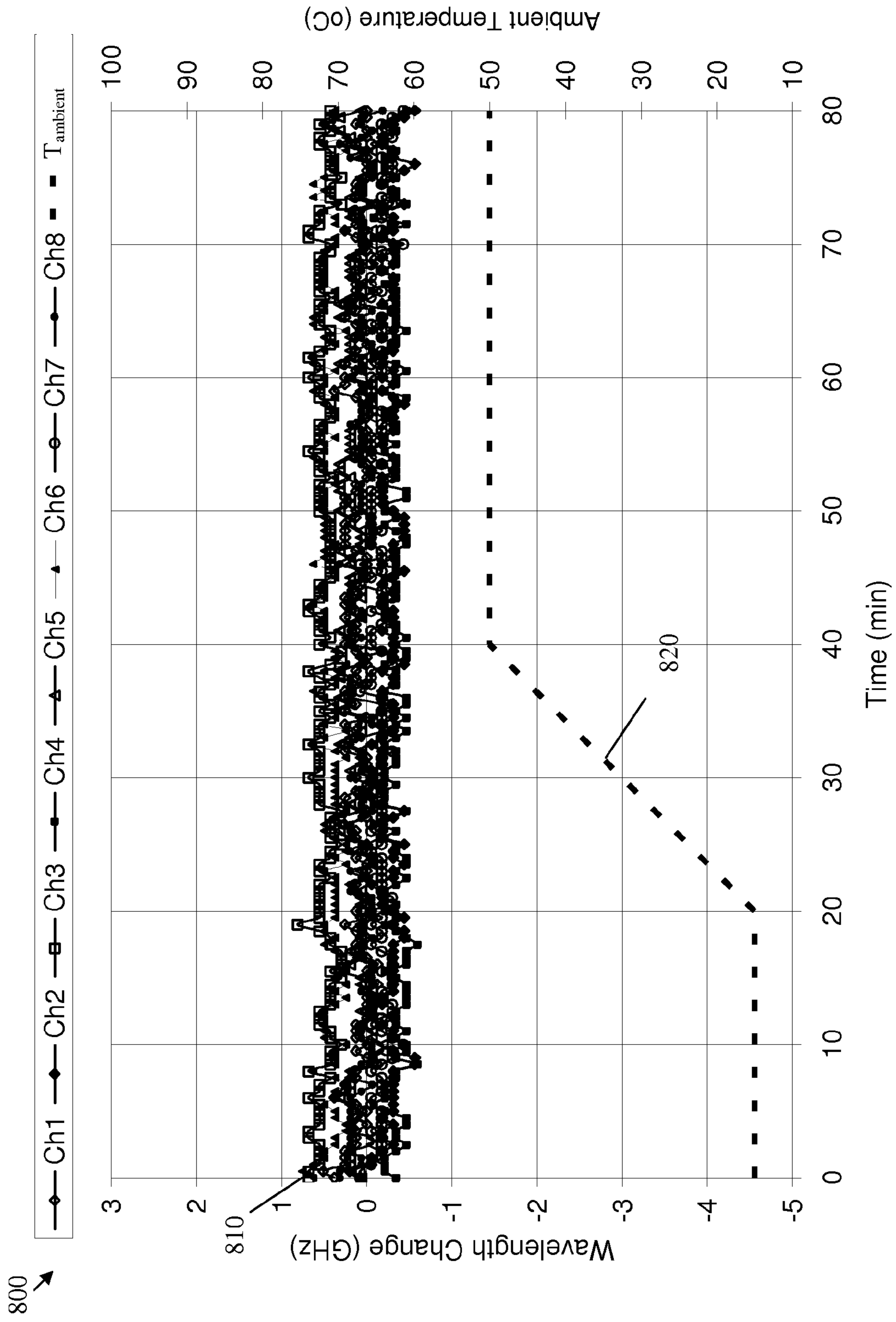

FIG. 8

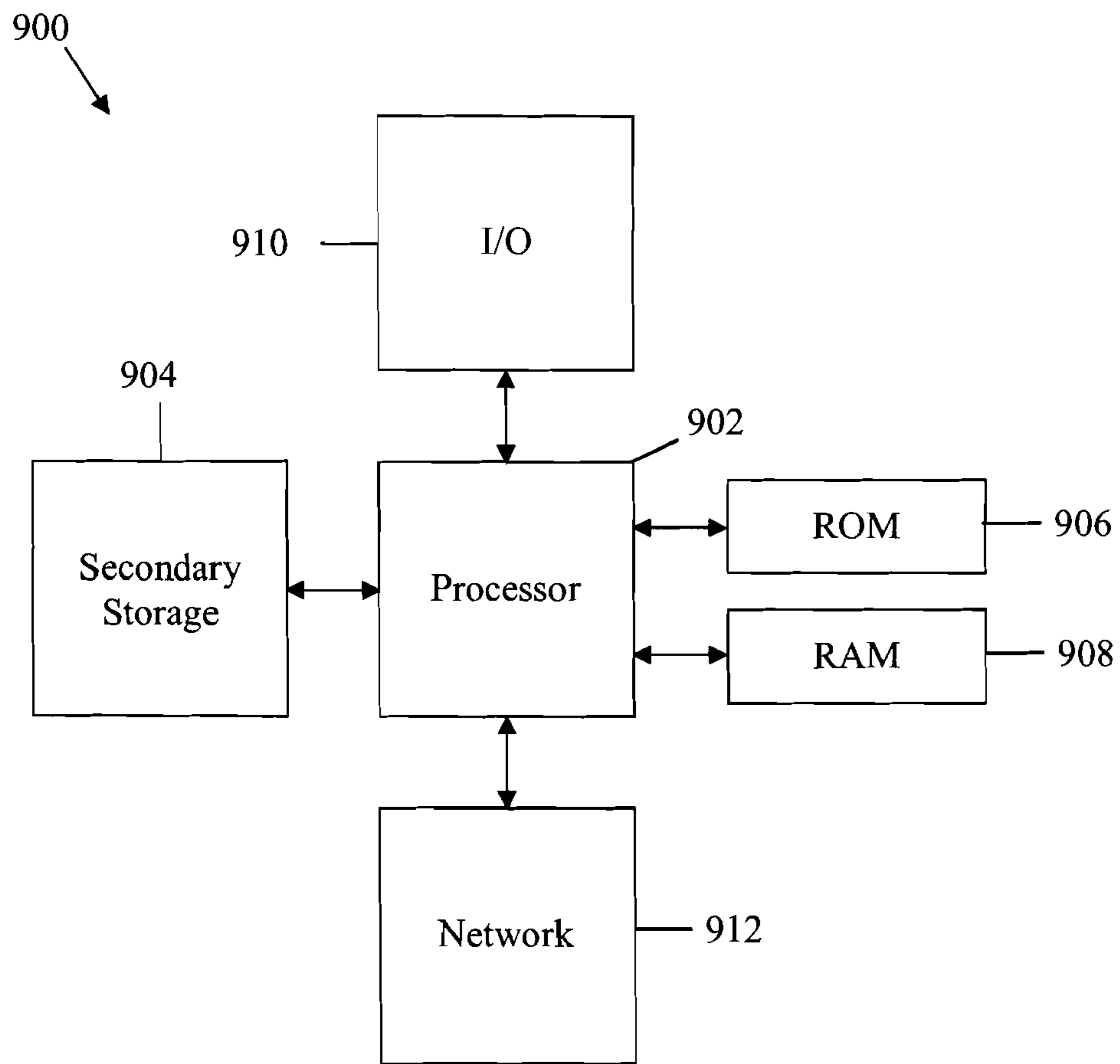

FIG. 9

1

**USE OF MULTIPLE SHARED WAVELENGTH
LOCKERS TO STABILIZE TRANSPONDERS
IN A WAVELENGTH DIVISION
MULTIPLEXING (WDM) NETWORK**

CROSS-REFERENCE TO RELATED
APPLICATIONS

The present application claims priority to U.S. Provisional Patent Application No. 61/362,792, filed Jul. 9, 2010 by Xiao Shen et al., and entitled "Use of Multiple Shared Wavelength Lockers to Stabilize a Large Number of Transponders in a Dense Wavelength Division Multiplexing (DWDM) Network," which is incorporated herein by reference as if reproduced in its entirety.

STATEMENT REGARDING FEDERALLY
SPONSORED RESEARCH OR DEVELOPMENT

Not applicable.

REFERENCE TO A MICROFICHE APPENDIX

Not applicable.

BACKGROUND

Conventional wavelength division multiplexing (WDM) transmitter arrays may employ semiconductor lasers as optical transmitters. The performance of WDM systems depends on the signal integrity from the laser sources, which may fluctuate due to variations in the environment (e.g., temperature, etc.) and/or conditions of the laser (e.g., age, quality control in the manufacturing process). A general dichotomy exists between Coarse WDM (CWDM) networks and Dense WDM (DWDM) networks, in that CWDM networks may comprise a relatively wide channel spacing (e.g., about 20 nanometers (nm) or about 2500 Gigahertz (GHz), while dense WDM (DWDM) networks may comprise a relatively narrow channel spacing (e.g., about 0.8 nm or about 100 GHz). Accordingly, CWDM networks may comprise substantially fewer channels (e.g., up to about 18 channels) than DWDM networks (e.g., up to about 128 channels). Typical CWDM networks and DWDM networks may be described in International Telecommunications Union (ITU) Standardization Section (ITU-T) publication G.984.2 and ITU-T G984.1 (respectively), both of which are incorporated herein by reference as if reproduced in their entirety.

Due to their respective channel spacing, signal integrity may be more critical in DWDM networks than in CWDM networks. For instance, while a relatively small fluctuation/variation in signal integrity (e.g., wavelength drift) may be acceptable in CWDM networks, an equivalent variation may substantially reduce service quality in DWDM networks. Consequently, many CWDM systems may implement some strategy for correcting wavelength float. One strategy for correcting wavelength float is to provide wavelength locking via a feedback system that compares the actual laser output wavelength to the target laser output wavelength. Such feedback systems may employ a wavelength locker (λ -locker) to detect a difference between output and target wavelengths (e.g., a wavelength deviation), and an element manager to adjust the laser output accordingly. Specifically the λ -locker may detect the wavelength deviation by comparing a reference signal to a signal transmitted through an etalon to determine a signal differential, e.g., a difference in phase, amplitude, frequency, or combinations thereof, which may

2

correspond to the output signal's deviation from the target wavelength. As such, the λ -locker may use the signal intensity differential to determine the wavelength deviation, which may be communicated to the element manager so that the laser's output can be adjusted accordingly. Wavelength locking techniques may be described in greater detail in U.S. patent application Ser. No. 12/579,196 filed on Oct. 14, 2009 by Hongbing Lei et al., and entitled "Wavelength Locker for Simultaneous Control of Multiple Dense Wavelength Division Multiplexing Transmitters", which is incorporated by reference herein as if reproduced in its entirety.

Conventional distributed wavelength locking schemes may employ one dedicated λ -locker for each downstream channel (i.e., one λ -locker per transmitter), thereby using a separate λ -locker to provide wavelength locking to each respective laser source. Specifically, a dedicated wavelength locker may be located between each of the optical transmitters and the optical multiplexer and may be configured to detect wavelength float in each optical transmitter's output signal before the plurality of output signals are multiplexed into a WDM signal. However, λ -lockers may be relatively expensive such that networks employing more λ -lockers (e.g., dedicated λ -lockers, or one λ -locker per channel) may be substantially more expensive than those that employ fewer wavelength lockers (e.g., one λ -locker for multiple channels). For instance, conventional centralized wavelength locking schemes may employ a centralized λ -locker (e.g., a single λ -locker for all channels), and hence may be a cost effective alternative to conventional distributed networks. Specifically, the centralized λ -locker may be located downstream from the optical multiplexer, and may be configured to detect wavelength float in a plurality of channels in the WDM signal.

SUMMARY

Disclosed herein is an apparatus comprising at least one processor configured to receive a WDM signal from a remote node, wherein the WDM signal comprises a first channel carrying a first remotely generated signal, a second channel carrying a second remotely generated signal, and a third channel, adapt the WDM signal into a composite WDM signal by dropping the first remotely generated signal from the first channel, adding a first locally generated signal to the first channel; and adding a second locally generated signal to the third channel, and provide wavelength locking to the first locally generated signal and the second locally generated signal without providing wavelength locking to the second remotely generated signal.

Also disclosed herein is an apparatus comprising a first transponder configured to generate a first optical signal, a second transponder configured to generate a second optical signal, an optical fiber configured to propagate a third optical signal, wherein the third optical signal is not generated by the apparatus, an optical multiplexer configured to combine the first optical signal, the second optical signal, and the third optical signal into a composite WDM optical signal, and a wavelength locker configured to wavelength lock the first optical signal and the second optical signal, but not the third optical signal, wherein the first optical signal and the second optical signal are wavelength locked using a first dither frequency that is different than a second dither frequency used to lock the third optical signal, and wherein the first optical signal and the second optical signal share the first dither frequency using a time division multiplexing (TDM) wavelength locking scheme that is localized to the apparatus.

Also disclosed herein is a method comprising assigning, by a network manager, a first dither frequency to a first interme-

diating node in a network and a second dither frequency to a second intermediate node in the network, wherein the first dither frequency is different than the second dither frequency, providing, by the first intermediate node, wavelength locking to a first plurality of optical signals in a first WDM signal, wherein the first plurality of optical signals are generated by the first intermediate node and comprise the first dither frequency, but not the second dither frequency, providing, by the second intermediate node, wavelength locking to a second plurality of optical signals in a composite WDM signal that comprises both the second plurality of optical signals and at least some of the first plurality of optical signals, wherein the second plurality of optical signals are generated by the second intermediate node and comprise the second dither frequency, but not the first dither frequency; and transmitting, by the second intermediate node, the composite WDM signal to a third intermediate node.

These and other features will be more clearly understood from the following detailed description taken in conjunction with the accompanying drawings and claims.

BRIEF DESCRIPTION OF THE DRAWINGS

For a more complete understanding of this disclosure, reference is now made to the following brief description, taken in connection with the accompanying drawings and detailed description, wherein like reference numerals represent like parts.

FIG. 1 illustrates an embodiment of a node for implementing a TDM wavelength locking scheme.

FIG. 2 illustrates an embodiment of a node for implementing a Frequency Division Multiplexed (FDM) wavelength locking scheme.

FIG. 3 illustrates an embodiment of a point-to-point (P2P) DWDM network.

FIG. 4 illustrates an embodiment of a complex DWDM network.

FIG. 5 illustrates an embodiment of an intermediate node configured to implement a shared wavelength locking scheme.

FIG. 6 illustrates an embodiment of a network architecture for implementing a shared wavelength locking scheme.

FIG. 7 illustrates another embodiment of a network architecture for implementing a shared wavelength locking scheme.

FIG. 8 is a graph that tracks wavelength drift in a shared wavelength locking network architecture.

FIG. 9 is an embodiment of a general-purpose computer system.

DETAILED DESCRIPTION

It should be understood at the outset that, although an illustrative implementation of one or more embodiments are provided below, the disclosed systems and/or methods may be implemented using any number of techniques, whether currently known or in existence. The disclosure should in no way be limited to the illustrative implementations, drawings, and techniques illustrated below, including the exemplary designs and implementations illustrated and described herein, but may be modified within the scope of the appended claims along with their full scope of equivalents.

To provide wavelength locking in a plurality of channels in a WDM signal, the centralized wavelength locker may first need to isolate each output signal corresponding to the channels that will receive wavelength locking. One method for achieving such isolation in the WDM signal is to introduce a

dither signal into the appropriate output signal. Specifically, a dither signal may comprise a low intensity singular tone (e.g., a small single tone component signal) that can be selectively introduced into an output signal and then used to distinguish the output signal from other output signals in a WDM signal. For instance, the WDM signal may be electronically filtered according to the frequency of the dither signal (dither frequency) to track a spectral component that carries the dither frequency. Various methods may exist for introducing dither signals into the output signal of a laser transmitter, such as by modulating the bias current of the transmitter at a rate that corresponds to the dither frequency. However, the centralized λ -locker can only isolate an output signal whose dither frequency is unique within the WDM signal, e.g., when no other output signals aside from the isolated output signal comprise a dither signal having the same dither frequency. As such, centralized wavelength locking schemes may use a multiple-access approach so that a single λ -locker may provide wavelength locking to multiple channels.

One centralized wavelength locking scheme may be a TDM wavelength locking scheme. The TDM wavelength locking scheme may sequentially introduce the same frequency dither signal into each of the optical channels according to a pre-determined sequence e.g., a TDM window comprising a plurality of timeslots (T1, T2, T3, etc.) assigned to the plurality of optical channels. The λ -locker may then track the spectral component corresponding to the dither frequency according to the pre-determined sequence, thereby isolating each output signal at the appropriate timeslot. Thereafter, the centralized λ -locker may detect the corresponding wavelength deviations in a manner similar to that used by the dedicated λ -locker. Hence, a TDM wavelength locking scheme may sequentially provide wavelength locking to each of the channels according to a TDM window.

FIG. 1 illustrates an embodiment of a node 100 for implementing a centralized TDM wavelength locking scheme. The node 100 may comprise a first laser transmitter (TX-1) 101, a second laser transmitter (TX-2) 102, a third laser transmitter (TX-3) 103, a fourth laser transmitter (TX-4) 104, an optical multiplexer (MUX) 105, a λ -locker (λ -locker₁₀₀) 106, an element manager 107, and a plurality of dither signal generators 111-114, arranged as shown in FIG. 1.

The laser transmitters 101-104 may be any devices used to transmit optical signals (e.g., output signals) in an optical network. In an embodiment, the TX-1 101 may be configured to transmit a first output signal (λ_1) in a first channel (CH1), the TX-2 102 may be configured to transmit a second output signal (λ_2) in a second channel (CH2), the TX-3 103 may be configured to transmit a third output signal (λ_3) in a third channel (CH3), and the TX-4 104 may be configured to transmit a fourth output signal (λ_4) in a fourth channel (CH4). Those of ordinary skill in the art will recognize that the node 100 may comprise any number of optical transmitters (e.g., TX-1, TX-2, . . . TX-N, where N is an integer greater than 1) configured to transmit any number of output signals (e.g., $\lambda_1, \lambda_2, \dots, \lambda_n$, where n is an integer greater than 1) in any number of Channels (e.g., CH1, CH2 . . . CHN), even though only four optical transmitters are described herein. The MUX 105 may be any device configured to multiplex a plurality of output signals into a WDM optical signal. The λ -locker₁₀₀ 106 may be any device configured to detect wavelength drift in one or more output signals. The element manager 107 may be any device configured to coordinate TDM wavelength locking in the node 100.

The dither signal generators 111-114 may be any device or devices capable of introducing, or facilitating the introduction of, a dither signal into the output signals of the optical

transmitters **101-104**. For instance, the dither signal generators **111-114** may be configured to introduce a dither signal into the output signal by modulating the bias current of the transmitters **101-104**. In an embodiment, the dither signal generators **111-114** may include: a first dither signal generator **111** configured to introduce a first dither signal (Dither- $1_{f_{100}}$) into the λ_1 ; a second dither signal generator **112** configured to introduce a second dither signal (Dither- $2_{f_{100}}$) into the λ_2 ; a third dither signal generator **113** configured to introduce a third dither signal (Dither- $3_{f_{100}}$) into the λ_3 ; and a fourth dither signal generator **114** configured to introduce a fourth dither signal (Dither- $4_{f_{100}}$) into the λ_4 . In an embodiment, the Dither- $1_{f_{100}}$, the Dither- $2_{f_{100}}$, the Dither- $3_{f_{100}}$, and the Dither- $4_{f_{100}}$ may all comprise a first dither frequency (f_{100}). In the same or other embodiments, the λ -locker $_{f_{100}}$ **106** may be configured to electronically filter the WDM signal according to the f_{100} .

In an embodiment, the element manager **107** may be configured to coordinate TDM wavelength locking in the node **100** by synchronizing the introduction of the dither signals into the output signals according to a predetermined sequence **190**, and then communicating the predetermined sequence **190** to the λ -locker $_{f_{100}}$ **106**. For instance, the element manager may coordinate the introduction of the Dither- $1_{f_{100}}$, the Dither- $2_{f_{100}}$, the Dither- $3_{f_{100}}$, and the Dither- $4_{f_{100}}$ into the λ_1 , the λ_2 , the λ_3 , and the λ_4 (respectively) according to the predetermined sequence **190**. The pre-determined sequence **190** may comprise any method or manner of coordinating the introduction of the dither signals into the output signals with the detection of the corresponding output signals by the λ -locker $_{f_{100}}$ **106**. In an embodiment, the pre-determined sequence **190** may comprise a repetitious sequence of a TDM window comprising a plurality of timeslots (e.g., T1, T2, T3, and T4) that are assigned to the respective channels or dither signals. For instance, the TDM window may comprise a first timeslot (T1) assigned to the Dither- $1_{f_{100}}$, a second timeslot (T2) assigned to the Dither- $2_{f_{100}}$, a third timeslot (T3) assigned to the Dither- $3_{f_{100}}$, and a fourth timeslot (T4) assigned to the Dither- $4_{f_{100}}$.

The λ -locker $_{f_{100}}$ **106** may use the pre-determined sequence **190** to determine which channel the isolated output signal corresponds to so that the correct target wavelength can be used to determine the corresponding wavelength deviation. For instance, the λ -locker $_{f_{100}}$ **106** may determine the wavelength deviation of the λ_1 by comparing the isolated signal's wavelength to the CH1's target wavelength at the T1, the wavelength float of the λ_2 by comparing the isolated signal's wavelength to the CH2's target wavelength at the T2, the wavelength float of the λ_3 by comparing the isolated signal's wavelength to the CH3's target wavelength at the T3, and the wavelength float of the λ_4 by comparing the isolated signal's wavelength to the CH4's target wavelength at the T4. Subsequently (or concurrently), the λ -locker $_{f_{100}}$ **106** may communicate the corresponding wavelength deviation to the element manager **107**. Alternatively, the wavelength deviation may be communicated to a central processing unit (CPU) or third party device used to independently or collectively correct the output signals.

Conventional FDM wavelength locking may be one alternative to conventional TDM wavelength. In a conventional FDM wavelength locking scheme, the dither signals may be applied at the same time, but may comprise different dither frequencies. For instance, a dither signal comprising a unique dither signal (e.g., f_{100} , f_{200} , f_{300} . . . $f_{n \times 100}$) may be continuously introduced into the various output signals (λ_1 , λ_2 , λ_3 . . . λ_n) such that the resulting spectral components (each of which corresponding to a different dither frequency) may be

contemporaneously (e.g., rather than sequentially) tracked to simultaneously isolate each of the output signals. Hence, the FDM wavelength locking scheme may use a dither signal comprising a unique dither frequency (e.g., f_{100} , f_{200} , f_{300} . . . $f_{n \times 100}$) to isolate each of the output signals (e.g., λ_1 , λ_2 , and λ_3 . . . λ_n).

FIG. 2 illustrates an embodiment of a node **200** for implementing an FDM wavelength locking scheme. The node **200** may comprise a TX-1 **201**, a TX-2 **202**, a TX-3 **203**, a TX-4 **204**, a MUX **205**, an FDM λ -locker (λ -locker $_{f_{100-f_{400}}}$) **206**, an element manager **207**, and a plurality of dither signal generators **211-214**, arranged as shown in FIG. 2. The TX-1 **201**, the TX-2 **202**, the TX-3 **203**, the TX-4 **204**, and the MUX **205** may be configured substantially similar to the TX-1 **101**, the TX-2 **102**, the TX-3 **103**, the TX-4 **104**, and the MUX **105**. In an embodiment, the TX-1 **201**, the TX-2 **202**, the TX-3 **203**, the TX-4 **204** may be configured to transmit a λ_1 , a λ_2 , a λ_3 , and a λ_4 (respectively) to the MUX **205**, who may be configured to multiplex the λ_1 , the λ_2 , the λ_3 , and the λ_4 into a WDM signal. The λ -locker $_{f_{100-f_{400}}}$ **206**, the element manager **207**, and the dither signal generators **211-214** may be configured somewhat similarly to the λ -locker $_{f_{100}}$ **106**, the element manager **107**, and the dither signal generators **111-114**, except that the λ -locker $_{f_{100-f_{400}}}$ **206**, the element manager **207**, and the dither signal generators **211-214** may be configured to implement an FDM wavelength locking scheme rather than a TDM wavelength locking scheme. Specifically, the dither signal generators **211-214** may be configured to generate a plurality of dither signals each of which may comprise a unique dither frequency (e.g., f_{100} , f_{200} , f_{300} , and f_{400}). For instance, the dither signal generators **211-214** may comprise: a first dither signal generator **211** configured to introduce a first dither signal comprising an f_{100} (Dither- $1_{f_{100}}$) into the λ_1 ; a second dither signal generator **212** configured to introduce a second dither signal comprising a second dither frequency (f_{200}) (Dither- $2_{f_{200}}$) into the λ_2 ; a third dither signal generator **213** configured to introduce a third dither signal comprising a third dither frequency (f_{300}) (Dither- $3_{f_{300}}$) into the λ_3 ; and a fourth dither signal generator **214** configured to introduce a fourth dither signal comprising a fourth dither frequency (f_{400}) (Dither- $4_{f_{400}}$) into the λ_4 , where $f_{100} \neq f_{200} \neq f_{300} \neq f_{400}$ (e.g., $f_{100} < f_{200} < f_{300} < f_{400}$). Accordingly, the element manager **207** may be configured to communicate the assigned dither frequencies (e.g., f_{100} to CH1, f_{200} to CH2, f_{300} to CH3, f_{400} to CH4, etc.) with the λ -locker $_{f_{100-f_{400}}}$ **206** so that the correct target wavelengths can be compared with the λ_1 , the λ_2 , the λ_3 , and the λ_4 to determine the corresponding wavelength deviations. Subsequently, the element manager **207** may need to communicate any new or modified dither frequency assignment to the λ -locker $_{f_{100-f_{400}}}$ **206** (e.g., that a new dither frequency (e.g., $f_{n \times 100}$) has been assigned to a newly added channel (e.g., CHN), that an existing channel's dither frequency assignment has been revoked/reassigned, etc.). The λ -locker $_{f_{100-f_{400}}}$ **206** may be configured to: isolate the λ_1 by electronically filtering a first portion of the WDM signal with a first radio-frequency (RF) filter comprising a passband centered around about the f_{100} ; isolate the λ_2 by electronically filtering a second portion of the WDM signal with a second RF filter comprising a passband centered around about the f_{200} ; isolate the λ_3 by electronically filtering a third portion of the WDM signal with a third RF filter comprising a passband centered around about the f_{300} ; and isolate the λ_4 by electronically filtering a fourth portion of the WDM signal with a fourth RF filter comprising a passband centered around about the f_{400} . The remaining portion of the WDM signal may be transmitted downstream, e.g., without being filtered by the λ -locker $_{f_{100-f_{400}}}$. In some embodiments,

the first, second, third, and fourth portions of the WDM signal may collectively comprise only about a nominal portion (e.g., less than about one percent) of the entire WDM signal, while the remaining portion of the WDM signal may comprise a substantial portion (e.g., more than about ninety-nine percent) of the entire WDM signal. As such, diverting the first, second, third, and fourth portions of the WDM signal may not substantially attenuate the WDM signal. In some embodiments, the entire WDM signal, the first, second, third, and fourth portions of the WDM signal, and/or the remainder of the WDM signal may be amplified by some other optical component coupled to the λ -locker_{f₁₀₀-f₄₀₀} (e.g., an amplifier). As such, the λ -locker_{f₁₀₀-f₄₀₀} **206** may contemporaneously provide wavelength locking to each of the transmitters **201-204**.

In summary, conventional centralized TDM and FDM wavelength locking schemes take different approaches to achieve centralized wavelength locking in DWDM networks. The TDM wavelength locking scheme sequentially isolates a plurality of output signals (e.g., $\lambda_1, \lambda_2, \lambda_3, \dots, \lambda_n$) by tracking a single spectral component corresponding to a single dither frequency (e.g., f_{100}) according to a pre-determined TDM window (e.g., λ_1 at T1, λ_2 at T2, \dots, λ_n at TN, etc.). In contrast, the FDM wavelength locking scheme isolates a plurality of output signals (e.g., $\lambda_1, \lambda_2, \lambda_3, \dots, \lambda_n$) by tracking a plurality of unique spectral components each of which correspond to a different dither frequency (e.g., $f_1, f_2, f_3, \dots, f_n$). Each approach may have its advantages/disadvantages depending on the network environment, architecture, etc. For instance, conventional FDM λ -lockers may be somewhat more costly than their TDM counterparts because FDM λ -lockers may employ a plurality of electronic filters (e.g., rather than just one electronic filter) such that the WDM signal may be filtered according to a plurality of dither frequencies. That is to say, λ -lockers comprising more electronic filters may, ceteris paribus, be more expensive than λ -lockers comprising fewer electronic filters. On the other hand, implementing a centralized TDM wavelength locking approach may introduce complexities into the wavelength locking scheme due to the synchronization required to distribute a single dither frequency amongst a plurality of channels, e.g., especially in DWDM networks comprising many channels. Nevertheless, both the conventional centralized TDM wavelength locking scheme and the conventional centralized FDM wavelength locking scheme may be suitable and/or cost-effective for providing centralized wavelength locking in relatively simple DWDM networks, e.g., point-to-point (P2P) DWDM networks.

FIG. 3 illustrates a point-to-point (P2P) DWDM network **300**. The term 'point-to-point' may be used in this disclosure to describe networks that do not comprise intermediate nodes configured to add/drop wavelengths to/from the WDM signal. For instance, the P2P DWDM network **300** may distribute the WDM optical signal to a plurality of subscribers (not shown), and hence may technically be a point-to-multipoint (P2MP) network. However, the P2P DWDM network **300** may nevertheless be referred to herein as a 'point-to-point' network because no wavelengths are added to the WDM signal by intermediate nodes prior to the WDM signal reaching a destination.

The P2P DWDM network **300** may comprise a first node **310** corresponding to a first point and a second node **320** corresponding to a second point. The first node **310** may be any device configured to transmit a WDM signal to the second node **320**, and may comprise a plurality of transponders **311-314**, a MUX **315**, a λ -locker **316**, and an element manager **317**, arranged as shown in FIG. 3. The transponders **311-314** may be any component or group of components that comprise the functionality of a transmitter and, optionally, the function-

ality of a dither signal generator. For instance, the transponders **311-314** may comprise an on-board transmitter and an on-board dither signal generator, or, alternatively, may comprise a stand-alone transmitter coupled to a stand-alone dither signal generator. Accordingly, the transponders **311-314** may generate or emit optical output signals (e.g., $\lambda_1, \lambda_2, \lambda_3$, and λ_4) that comprise a plurality of dither signals (e.g., Dither-1, Dither-2, Dither-3, and Dither-4). For instance, the dither transponders **311-314** may comprise: a first transponder (TRX-1) **311** configured to transmit a λ_1 comprising a Dither-1 in a CH1; a second transponder (TRX-2) **312** configured to transmit a λ_2 comprising a Dither-2 in a CH2; a third transponder (TRX-3) **313** configured to transmit a λ_3 comprising a Dither-3 in a CH3; and a fourth transponder (TRX-4) **314** configured to transmit a λ_4 comprising a Dither-4 in a CH4. The MUX **315** may be configured substantially similar to the MUX **105**.

The first node **310** may be configured to implement either a TDM wavelength locking architecture or an FDM wavelength locking architecture. For instance, the Dither-1, the Dither-2, the Dither-3, and the Dither-4 may comprise substantially the same dither frequency (e.g., f_{100}) when the node **310** is configured to implement a conventional TDM wavelength locking scheme. Alternatively, the Dither-1, the Dither-2, the Dither-3, and the Dither-4 may comprise substantially unique dither frequencies (e.g., $f_{100}, f_{200}, f_{300}$, and f_{400}) when the node **310** is configured to implement a conventional FDM wavelength locking scheme. Accordingly, the λ -locker **316** and the element manager **317** may be configured substantially similar to the λ -locker_{f₁₀₀} **106** and the element manager **107** when the first node **310** is configured to implement a conventional TDM wavelength locking scheme. Alternatively, the λ -locker **316** and the element manager **317** may be configured substantially similar to the λ -locker_{f₁₀₀-f₄₀₀} **206** and the element manager **207** when the first node **310** is configured to implement an FDM wavelength locking scheme.

Conventional centralized wavelength locking schemes, such as the TDM and FDM wavelength locking schemes described above, may be well suited and cost effective for simple optical networks, such as the P2P DWDM network **300**. However, conventional centralized wavelength locking schemes may be ill suited and/or less cost effective for large, complex optical networks, such as DWDM networks comprising one or more intermediate nodes that are configured to add/drop channels to/from the WDM signal. See, e.g., FIG. 4, infra. For instance, conventional centralized TDM wavelength locking schemes may require massive synchronization at the network level when multiple intermediate nodes are located remotely from one another, e.g., by several kilometers (km). Correspondingly, conventional centralized FDM wavelength locking schemes may require massive coordinate at the network level such that each channel is associated with a different dither frequency. For instance, dither frequencies may occasionally need to be re-assigned (e.g., when new channels are added, existing channels are removed, etc.), thereby causing substantial portions of the network to be occasionally shut down or put off-line to implement the re-assignment. For example, it may be important that all parties involved in a dither frequency assignment/re-assignment coordinate their actions (e.g., the parties start and stop using the dither frequency at the same time that the λ -locker re-associates the dither frequency with updated channel assignment) so that errors do not occur. Hence, conventional centralized TDM or FDM wavelength locking schemes may require substantial synchronization and/or coordination at the network level. Additionally, dither signals that are generated

remotely may be substantially attenuated upon reaching the TDM or FDM λ -locker, thereby making it difficult to track the corresponding spectral component in the WDM signal. As such, implementation and/or maintenance of conventional centralized TDM or FDM wavelength locking schemes may become unpractical in large, complex, and/or evolving DWDM networks, thereby reducing the scalability of conventional centralized approaches.

Further, conventional TDM and FDM centralized wavelength locking schemes (i.e., using one λ -locker for the entire network) may be unable to provide wavelength locking to all channels or transmitters in some complex DWDM networks. For instance, some DWDM networks may use different wavelengths on different segments (e.g., use λ_1 - λ_{10} on a first segment and λ_{11} - λ_{20} on a second segment, etc.), and consequently there may be no suitable location to place a centralized λ -locker in the DWDM network, e.g., there may be no stretch of fiber that carries all wavelengths. See, e.g., FIG. 4, infra. The same or other DWDM networks may reuse wavelengths on various segments (e.g., use λ_1 to carry a first signal on a first segment, drop λ_1 at the end of the first segment, and then re-use λ_1 to carry a second signal on a second segment). See, e.g., FIG. 4, infra (eastbound traffic λ_{j+1} - λ_k is used between P_1 and P_2 , dropped at P_2 , and then re-used between P_3 and P_4). In such networks, multiple λ -lockers may be required to provide wavelength locking to all transponders. However, distributing conventional TDM λ -lockers throughout the network (e.g., according to a conventional TDM wavelength locking scheme that synchronizes multiple TDM λ -lockers) may require that even more parties be coordinated/synchronized (e.g., additional λ -lockers), thereby making synchronization at the network level even more challenging. Likewise, distributing conventional FDM λ -lockers throughout the network (e.g., according to a conventional FDM wavelength locking scheme that uses multiple FDM λ -lockers) may substantially increase the cost of providing wavelength locking in the DWDM network (e.g., due to number of relatively expensive FDM λ -lockers). Additionally, network administrators may find it difficult to coordinate the allocation of large numbers of dither frequencies in a distributed FDM network, especially as channels/wavelengths are added and/or dropped at various remote node locations. Hence, distributing multiple FDM capable λ -lockers throughout the network may substantially increase the cost of providing wavelength locking in the DWDM network. As such, a simpler and/or more cost effective scheme for providing wavelength locking in DWDM networks is desired.

Disclosed herein is a shared wavelength locking scheme for using multiple shared λ -lockers to provide wavelength locking to a large number of transponders in a DWDM network. The shared wavelength locking scheme may distribute shared λ -lockers to a plurality of intermediate nodes, e.g., any remote nodes comprising add/drop sites. Each shared λ -locker may be configured to provide wavelength locking only to those output signals that are generated locally, while ignoring output signals that are not generated locally. For instance, a distributed λ -locker may provide wavelength locking to any output signals that are generated by the hosting or proximately located intermediate node, while ignoring output signals that are not generated by the hosting or proximately intermediate node. The distributed λ -locker may differentiate locally generated output signals from non-locally generated output signals according to the former's inclusion of a unique dither frequency, which may serve as an RF identification (ID) tag. For instance, each intermediate node may be assigned a unique dither frequency (e.g., P_1 , P_2 , . . . and P_N may be assigned f_{100} - f_{200} , and $f_{N \times 100}$, respectively)

such that only those output signals generated at the given intermediate node may comprise the corresponding dither frequency. Accordingly, the shared λ -locker may be configured to electronically filter the WDM signal according to the corresponding unique dither frequency, thereby isolating the locally generated output signals from the non-locally generated output signals. The shared λ -lockers and element managers may then provide wavelength locking to the local transmitters according to a localized TDM wavelength locking scheme.

The shared wavelength locking scheme may offer several advantages over conventional centralized wavelength locking schemes. For instance, each shared λ -locker may electronically filter the WDM signal at only the corresponding dither frequency (rather than at a plurality of dither frequencies), thereby allowing the shared λ -lockers to comprise fewer electronic components than conventional FDM λ -lockers (e.g., which may typically comprise as many as one RF filter per channel). Thus, the shared wavelength locking scheme may offer cost savings over distributed FDM wavelength locking schemes. Further, the shared wavelength locking scheme may only need localized synchronization, rather than network-wide synchronization, e.g., as would be required by a conventional distributed TDM wavelength locking schemes. For instance, the shared λ -lockers may only need to communicate with a network manager upon initialization, e.g., when the locker is physically installed at a node, to receive a unique dither frequency assignment. Subsequently (e.g., after receiving the unique dither frequency assignment), the shared λ -locker may operate substantially independently such that no further network level coordination is required with respect to wavelength locking. Consequently, the management of wavelength locking at the respective intermediate nodes may be substantially localized, thereby avoiding many of the problems associated with coordinating multi-component synchronization on the network level. As such, the shared wavelength locking scheme may be more scalable for large/complex DWDM networks than conventional TDM or FDM wavelength locking schemes.

FIG. 4 illustrates a network architecture 400 for implementing a shared wavelength locking scheme. In an embodiment, the network architecture 400 may be similar to ring type architectures that may commonly be found in metropolitan (metro) and/or regional DWDM networks. The network 400 may comprise a first node (P_1) 410, a first eastern λ -locker (WL1_E) 412, a first western λ -locker (WL1_W) 414, a second node (P_2) 420, a second eastern λ -locker (WL2_E) 422, a second western λ -locker (WL2_W) 424, a third node (P_3) 430, a third eastern λ -locker (WL3_E) 432, a third western λ -locker (WL3_W) 434, a fourth node (P_4) 440, a fourth eastern λ -locker (WL4_E) 442, and a fourth first western λ -locker (WL4_W) 444, arranged as shown in FIG. 4. The nodes 410-440 may communicate with one another via an optical communication medium, shown by the center ring (i.e., the solid ring), which may carry traffic in both an 'East' direction (e.g., a clockwise direction) and a 'West' direction (e.g., a counterclockwise direction). Hence, traffic propagated in the 'East' direction may be referred to herein as 'eastbound traffic', while traffic propagated in the 'West' direction may be referred to as 'westbound traffic'. The traffic may be carried in a WDM signal comprising a plurality of wavelengths (λ_1 - λ_n). The WDM signal may be broken up into four bands; a first band (λ_1 - λ_j), a second band (λ_{j+1} - λ_k), a third band (λ_{k+1} - λ_m), and a fourth band (λ_{m+1} - λ_n), where j is an integer greater than 1, k is an integer greater than j , m is an integer greater than j , and n is an integer greater than m (e.g., $j < k < m < n$). The network architecture may be divided into four segments, a first seg-

ment (S_{12}) spanning between the P_1 410 and the P_2 420, a second segment (S_{23}) spanning between the P_2 420 and the P_3 430, a third segment (S_{34}) spanning between the P_3 430 and the P_4 440, and a fourth segment (S_{41}) spanning between the P_4 440 and the P_1 410.

The λ_1 - λ_j may be represented as a dashed line in the network architecture 400, and may be used to carry traffic communicated between the P_2 420 and the P_3 430 over the S_{23} . For instance, the P_2 420 may send the λ_1 - λ_j to the P_3 430 as eastbound traffic (e.g., via S_{23}), while the P_3 430 may send the λ_1 - λ_j to the P_2 420 as westbound traffic (e.g., via S_{23}). Additionally, the λ_1 - λ_j may be re-used to carry traffic communicated between the P_4 440 and the P_1 410 over the S_{41} . For instance, the P_4 440 may send the λ_1 - λ_j to the P_1 410 as eastbound traffic (e.g., via S_{41}), while the P_1 410 may send the λ_1 - λ_j to the P_4 440 as westbound traffic (e.g., via S_{41}).

The λ_{j+1} - λ_k may be represented as a dot-dot-dashed line in the network architecture 400, and may be used to carry traffic communicated between the P_1 410 and the P_2 420 over the S_{12} . For instance, the P_1 410 may send the λ_{j+1} - λ_k to the P_2 420 as eastbound traffic (e.g., via S_{12}), while the P_2 420 may send the λ_{j+1} - λ_k to the P_1 410 as westbound traffic (e.g., via S_{12}). Additionally, the λ_{j+1} - λ_k may be re-used to carry traffic communicated between the P_3 430 and the P_4 440 over the S_{34} . For instance, the P_3 430 may send the λ_{j+1} - λ_k to the P_4 440 as eastbound traffic (e.g., via S_{34}), while the P_4 440 may send the λ_{j+1} - λ_k to the P_3 430 as westbound traffic (e.g., via S_{34}).

The λ_{k+1} - λ_m may be represented as a dotted line in the network architecture 400, and may be used to carry traffic communicated between the P_2 420 and the P_4 440 over two paths, S_{12}/S_{41} and S_{34}/S_{23} . For instance, the P_2 420 may send the λ_{k+1} - λ_m to the P_4 440 as eastbound traffic (e.g., via S_{23} and S_{34}) or as westbound traffic (e.g., via S_{12} and S_{41}), while the P_4 440 may send the λ_{k+1} - λ_m to the P_2 420 as eastbound traffic (e.g., via S_{41} and S_{12}), or as westbound traffic (e.g., via S_{34} and S_{23}). Accordingly, neither the P_1 410 nor the P_3 430 may be configured to add or drop any of wavelengths/signals within the λ_{k+1} - λ_m .

The λ_{m+1} - λ_n may be represented as a dot-dashed line in the network architecture 400, and may be used to carry traffic communicated between the P_1 410 and the P_3 430 over all of the S_{12} , the S_{23} , the S_{34} , and S_{41} . For instance, the P_1 410 may send the λ_{m+1} - λ_n to the P_3 430 as eastbound traffic (e.g., via S_{12} and S_{23}) or as westbound traffic (e.g., via S_{41} and S_{34}), while the P_3 430 may send the λ_{m+1} - λ_n to the P_1 410 as eastbound traffic (e.g., via S_{34} and S_{41}) or as westbound traffic (e.g., via S_{23} and S_{12}). Accordingly, neither the P_2 420 nor the P_4 440 may be configured to add or drop any of wavelengths/signals within the λ_{m+1} - λ_n .

In an embodiment, a unique dither frequency may be assigned to each of the P_1 410, the P_2 420, the P_3 430, and the P_4 440. For instance, an f_{100} may be assigned to the P_1 410, an f_{200} may be assigned to the P_2 420, an f_{300} may be assigned to the P_3 430, and an f_{400} may be assigned to the P_4 440. Accordingly, a dither frequency signal comprising the respective assigned dither frequencies may be included in the output signals generated by the P_1 410, the P_2 420, the P_3 430, and the P_4 440. For instance, the P_1 410 may include a dither signal corresponding to the f_{100} (Dither $_{f100}$) in each of its output signals in a TDM manner, the P_2 420 may include a dither signal corresponding to the f_{200} (Dither $_{f200}$) in each of its output signals, the P_3 430 may include a dither signal corresponding to the f_{300} (Dither $_{f300}$) in each of its output signals, and the P_4 440 may include a dither signal corresponding to the f_{400} (Dither $_{f400}$) in each of its output signals.

The $WL1_E$ 412, the $WL1_W$ 414, the $WL2_E$ 422, the $WL2_W$ 424, the $WL3_E$ 432, the $WL3_W$ 434, the $WL4_E$ 442, and the $WL4_W$ 444 may be shared λ -lockers that are configured to provide wavelength locking to their corresponding nodes according to the shared wavelength locking scheme. For instance: the $WL1_E$ 412 and the $WL1_W$ 414 may provide wavelength locking to signals generated by the P_1 410 by electronically filtering the WDM signals according to the f_{100} ; the $WL2_E$ 422 and the $WL2_W$ 424 may provide wavelength locking to signals generated by the P_2 420 by electronically filtering the WDM signals according to the f_{200} ; the $WL3_E$ 432 and the $WL3_W$ 434 may provide wavelength locking to signals generated at the P_3 430 by electronically filtering the WDM signals according to the f_{300} ; and the $WL4_E$ 442 and the $WL4_W$ 444 may provide wavelength locking to signals generated at the P_4 440 by electronically filtering the WDM signals according to the f_{400} .

In an embodiment, each of the $WL1_E$ 412 and the $WL2_E$ 422, the $WL3_E$ 432, and the $WL4_E$ 442 may provide wavelength locking to eastbound traffic generated by the P_1 410, the P_2 420, the P_3 430, and the P_4 440 (respectively), while each of the $WL1_W$ 414, the $WL2_W$ 424, the $WL3_W$ 434, and the $WL4_W$ 444 may provide wavelength locking to westbound traffic generated by the P_1 410, the P_2 420, the P_3 430, and the P_4 440 (respectively).

In an embodiment, the $WL1_E$ 412 may provide wavelength locking to all eastbound traffic (e.g., λ_{j+1} - λ_k and λ_{m+1} - λ_n) transmitted by the P_1 410 over the S_{12} , but may ignore all other eastbound traffic (e.g., λ_{k+1} - λ_m), while the $WL1_W$ 414 may provide wavelength locking to all westbound traffic (e.g., λ_1 - λ_j and λ_{m+1} - λ_n) transmitted by the P_1 410 over the S_{41} , but may ignore all other westbound traffic (e.g., λ_{k+1} - λ_m).

In an embodiment, the $WL2_E$ 422 may provide wavelength locking to the eastbound traffic (e.g., λ_1 - λ_j and λ_{k+1} - λ_m) transmitted by the P_2 420 over the S_{23} , but may ignore all other eastbound traffic (e.g., λ_{m+1} - λ_n). The $WL2_W$ 424 may provide wavelength locking to all westbound traffic (e.g., λ_{j+1} - λ_k and λ_{k+1} - λ_m) transmitted by the P_2 420 over the S_{12} , but may ignore all other westbound traffic (e.g., λ_{m+1} - λ_n).

In an embodiment, the $WL3_E$ 432 may provide wavelength locking to the eastbound traffic (e.g., λ_{j+1} - λ_k and λ_{m+1} - λ_n) transmitted by the P_3 430 over the S_{34} , but may ignore all other eastbound traffic (e.g., λ_{k+1} - λ_m), while the $WL3_W$ 434 may provide wavelength locking to all westbound traffic (e.g., λ_1 - λ_j and λ_{m+1} - λ_n) transmitted by the P_3 430 over the S_{23} , but may ignore all other westbound traffic (e.g., λ_{k+1} - λ_m).

In an embodiment, the $WL4_E$ 442 may provide wavelength locking to the eastbound traffic (e.g., λ_1 - λ_j and λ_{k+1} - λ_m) transmitted by the P_4 440 over the S_{41} , but may ignore all other eastbound traffic (e.g., λ_{m+1} - λ_n) transmitted over S_{41} , while the $WL4_W$ 444 may provide wavelength locking to all westbound traffic (e.g., λ_{j+1} - λ_k and λ_{k+1} - λ_m) transmitted by the P_4 440 over the S_{34} , but may ignore all other westbound traffic (e.g., λ_{m+1} - λ_n) transmitted over S_{41} .

In an embodiment, each of the $WL1_E$ 412, the $WL1_W$ 414, the $WL2_E$ 422, the $WL2_W$ 424, the $WL3_E$ 432, the $WL3_W$ 434, the $WL4_E$ 442, and the $WL4_W$ 444 may sequentially provide wavelength locking according to their own localized TDM sequence (e.g., two separate TDM windows per node: one for locally generated eastbound traffic and one for locally generated westbound traffic). One or more of the individual channels may be locally disabled and/or locally enabled by the assigned node without intervention and/or cooperation on the network level in respect to wavelength locking, e.g., without coordination by a network manager. For example, the P_1 410 may locally disable/enable any channel corresponding to eastbound traffic (λ_{j+1} - λ_k and λ_{m+1} - λ_n) or westbound traffic

(λ_1 - λ_j and λ_{m+1} - λ_n), the P_2 **420** may locally disable/enable any channel corresponding to eastbound traffic (e.g., λ_1 - λ_j and λ_{k+1} - λ_m) or westbound traffic (λ_{j+1} - λ_k and λ_{k+1} - λ_m), the P_3 **430** may locally disable/enable any channel corresponding to eastbound traffic (λ_{j+1} - λ_k and λ_{m+1} - λ_n) or westbound traffic (λ_1 - λ_j and λ_{m+1} - λ_n), and the P_4 **440** may locally disable/enable any channel corresponding to eastbound traffic (λ_1 - λ_j and λ_{k+1} - λ_m) or westbound traffic (λ_{j+1} - λ_k and λ_{k+1} - λ_m). In some embodiments, locally enabling/disabling a channel may comprise assigning/revoking a timeslot assignment in the relevant localized TDM sequence/window, but may not comprise changing any existing dither frequency assignments.

FIG. 5 illustrates an embodiment of an intermediate node **500** that may be used in a shared wavelength locking network. The intermediate node **500** may be assigned a fifth dither frequency (f_{500}), and may comprise a demultiplexer (DeMUX) **501**, a receiver for a third channel (RX-3) **503**, a receiver for a fourth channel (RX-4) **504**, a TRX-3_{f500} **513**, a TRX-4_{f500} **514**, an optical amplifier **515**, a MUX **505**, a λ -locker_{f500} **506**, and an element manager **507**. The optical amplifier may be any device or component capable of amplifying a WDM optical signal. For instance, the optical amplifier **515** may be configured to receive a WDM signal (e.g. from an upstream node), amplify the WDM signal, and forward the amplified WDM signal to the DeMUX **501**. The DeMUX **501** may be any optical component or device capable of de-multiplexing a WDM signal into a plurality of optical signals corresponding to a plurality of channels. For instance, the DeMUX **501** may de-multiplex the amplified WDM optical signal into a λ_1 corresponding to a CH1, a λ_2 corresponding to a CH2, a λ_3 corresponding to a CH3, and a λ_4 corresponding to a CH4. The RX-3 **503** and RX-4 **504** may be any component capable of receiving an optical signal. For instance, the RX-3 **503** and RX-4 **504** may be configured to receive λ_3 and λ_4 , respectively. The TRX-3_{f500} **513** and the TRX-4_{f500} **514** may be configured somewhat similarly to the TRX-3 **313** and the TRX-4 **314** as described above. In an embodiment, the TRX-3_{f500} **513** and the TRX-4_{f500} **514** may be configured to transmit optical signals λ_3' and λ_4' in the CH3 and the CH4, respectively. The λ_3' may comprise substantially the same wavelength, but different data, than the λ_3 , and the λ_4' may comprise substantially the same wavelength, but different data, than the λ_4 . Hence, the intermediate node **500** may re-use the wavelengths corresponding to λ_3 and the λ_4 to carry the λ_3' and the λ_4' .

The λ -locker_{f500} **506** may be configured to provide wavelength locking to the TRX-3_{f500} **513** and the TRX-4_{f500} **514** to correct wavelength drift in the λ_3' and the λ_4' , respectively, but may otherwise ignore (i.e., not provide wavelength locking to) the optical signals λ_1 and λ_2 . For instance, the TRX-3_{f500} **513** and the TRX-4_{f500} **514** may be configured to introduce a Dither-3_{f500} and a Dither-4_{f500} into the λ_3' and the λ_4' , respectively. The Dither-3_{f500} and the Dither-4_{f500} may correspond to the f_{500} , which may be unique to the intermediate node **500** such that no signals generated in other network nodes comprise a dither signal corresponding to the f_{500} . In an embodiment, the Dither-3_{f500} and the Dither-4_{f500} may comprise the same dither signal that is introduced into the CH3 and the CH4 at different times. Hence, the λ_1 and λ_2 may not comprise a dither signal having the f_{500} , and therefore the λ_3' and λ_4' may be isolated from the λ_1 and λ_2 by electronically filtering the WDM signal according to the f_{500} .

In an embodiment, the TRX-3_{f500} **513**, the TRX-4_{f500} **514**, the λ -locker_{f500} **506**, and the element manager **507** may be configured to implement a localized TDM wavelength locking scheme. For instance, the element manager may coordi-

nate a localized synchronization of the TRX-3_{f500} **513**, the TRX-4_{f500} **514**, and the λ -locker_{f500} **506** according to a predetermined localized sequence **590**. Pursuant to the predetermined localized sequence **590**, the TRX-3_{f500} **513** and the TRX-4_{f500} **514** may coordinate their introductions of the Dither-3_{f500} and the Dither-4_{f500} into the λ_3' and λ_4' (respectively) with the λ -locker_{f500}'s **506** sequential detection of the wavelength drift associated with the λ_3' and λ_4' . The predetermined localized sequence **590** may comprise a localized TDM window comprising a T1 and a T2 that are allocated to the Dither-3_{f500} and the Dither-4_{f500} (respectively). In an embodiment, the TDM window may not comprise any timeslots corresponding to non-locally generated output signals (e.g., λ_1 and λ_2). In an embodiment, the localized TDM window may not be communicated to any devices or components outside of the intermediate node **500**, e.g., may not be communicated to a centralized network manager or coordinated with any other intermediate nodes, e.g., the TDM window may be communicated via a separate communication channel or medium in the intermediate node **500**. In other embodiments, the localized TDM window may be indirectly communicated outside of the intermediate node **500** (e.g., as overhead in the WDM signal), but may not provide synchronization to any other intermediate nodes (e.g., other nodes/network-devices may be configured to ignore the overhead containing the localized TDM window).

FIG. 6 illustrates another embodiment of a network architecture **600** for implementing a shared wavelength locking scheme. The network architecture **600** may comprise a plurality of nodes **610-630** and an optical network **650**. The plurality of nodes **610-630** may be configured substantially similar to the intermediate node **500**, with each of the nodes **610-630** being assigned a unique dither frequency. For instance, a first node (node-1) **610** may be assigned the f_{100} , a second node (node-2) **620** may be assigned the f_{200} , and a K^{th} node (node-K) **630** may be assigned a k^{th} dither frequency ($f_{k \times 100}$), where K is an integer greater than 2, and k is an integer greater than 2. The optical network **650** may comprise any passive or active distribution network configured to transport a WDM signal between the nodes **610-630**. The MUX **616**, the λ -locker_{f100} **617**, and the element manager **618** may be configured substantially similarly to the MUX **505**, the λ -locker_{f100} **506**, and the element manager **507**.

The node-1 **610** may comprise a TRX-1_{f100} **601**, a TRX-3_{f100} **603**, a TRX-M_{f100} **615**, a MUX **616**, a λ -locker_{f100} **617**, and an element manager **618**, arranged as shown in FIG. 6. The TRX-1_{f100} **601**, the TRX-3_{f100} **603**, and the TRX-M_{f100} **615** may be configured to transmit a λ_1 , a λ_3 , and a λ_m to the MUX **616**. In an embodiment, the TRX-1_{f100} **601**, the TRX-3_{f100} **603**, and the TRX-M_{f100} **615** may sequentially introduce a Dither-1_{f100}, a Dither-3_{f100}, and a dither signal corresponding to the CHM (Dither-M_{f100}) into the λ_1 , the λ_3 , and the λ_m (respectively) according to a first localized sequence, which may be provided by the element manager **618**. In an embodiment, the Dither-1_{f100}, the Dither-3_{f100}, and the Dither-M_{f100} may comprise the same dither signal inserted into different channels at different times. Upon receiving the output signals, the MUX **616** may multiplex the λ_1 , the λ_3 , and the λ_m (e.g., as well as one or more signals that may have been generated locally by another transmitter located with the node-1, such as a $\lambda_5, \dots, \lambda_{m-2}$, etc.) to form the first WDM signal, which may thereafter be forwarded to the λ -locker_{f100} **617**. Specifically, the λ_1 , the λ_3 , and the λ_m may be carried in a CH1, a CH3, and an M^{th} channel (CHM), respectively, of the first WDM signal. The first localized sequence may be configured substantially similarly to the localized sequence **590**, and may comprise a plurality of

timeslots allocated to the channels carrying the locally generated output signals. Each of the Dither-1_{f₁₀₀}, the Dither-3_{f₁₀₀}, and the Dither-M_{f₁₀₀} may comprise the f₁₀₀, and may be associated with their own respective timeslot in the first localized sequence, e.g., a timeslot assigned to the corresponding locally generated output signal. The first localized sequence may be further communicated to the λ-locker_{f₁₀₀} 617 by the element manager 618 such that a detection of the wavelength deviation in each of the CH1, the CH3, and the CHM, can be synchronized with the introduction of the Dither-1_{f₁₀₀}, the Dither-3_{f₁₀₀}, and the Dither-M_{f₁₀₀} (respectively) into the λ₁, λ₃, and λ_m (respectively). In an embodiment, the first localized sequence may not be communicated outside the node-1 610 such that the first localized sequence is localized to the node-1 610. In another embodiment, the first localized sequence may be indirectly communicated outside of the node-1 610 (e.g., in the WDM overhead), but may not be used to synchronize wavelength locking in any other nodes. That is to say, the first localized sequence may be locally relevant, but may not be globally relevant.

The node-2 620 may comprise a TRX-2_{f₂₀₀} 602, a TRX-4_{f₂₀₀} 604, a TRX-N_{f₂₀₀} 625, an MUX 626, a λ-locker_{f₁₀₀} 627, an element manager 628, a DeMUX 629, and an RX-1 641, arranged as shown in FIG. 6. The MUX 626, the λ-locker_{f₁₀₀} 627, the element manager 628, the DeMUX 629, and the RX-1 641 may be configured somewhat similarly to the MUX 505, λ-locker_{f₅₀₀} 506, the element manager 507, the DeMUX 501, and the RX-3 503. In an embodiment, the node-2 620 may be coupled directly downstream from the node-1 610 such that the node-2 620 receives the first WDM signal. The first WDM signal may be demultiplexed by the DeMUX 629 into the λ₁, the λ₃, and the λ_m. The λ₁ may be received by the RX-1 641, e.g., may be dropped from the WDM signal by the node-2 620, while the λ₃ and the λ_m may be forwarded to the MUX 627. In an embodiment, the TRX-2_{f₂₀₀} 602, the TRX-4_{f₂₀₀} 604, and the TRX-N_{f₂₀₀} 625 may transmit a λ₂, a λ₄, and a λ_n (respectively) in a CH2, a CH4, and an Nth channel (CHN) (respectively) of a second WDM signal. Specifically, the MUX 626 may multiplex the λ₂, the λ₃, the λ₄, the λ_m, and the λ_n to form the second WDM signal, which may be forwarded to the λ-locker_{f₂₀₀} 627. Those of ordinary skill in the art will recognize that the second WDM signal may comprise one or more additional locally generated signals (e.g., λ_{n-4}, λ_{n-2}, etc.) and/or one or more additional remotely generated signals (e.g., λ_{m-4}, λ_{m-2}, etc.).

In an embodiment, the TRX-2_{f₂₀₀} 602, the TRX-4_{f₂₀₀} 604, and the TRX-N_{f₂₀₀} 625 may sequentially introduce a Dither-2_{f₂₀₀}, a Dither-4_{f₂₀₀}, and a dither signal corresponding to the CHN (Dither-N_{f₂₀₀}) into the λ₂, the λ₄, and the λ_n (respectively) according to a second localized sequence provided by the element manager 628, where each of the Dither-2_{f₂₀₀}, the Dither-4_{f₂₀₀}, and the Dither-N_{f₂₀₀} comprise the f₂₀₀. In an embodiment, the Dither-2_{f₂₀₀}, the Dither-4_{f₂₀₀}, and the Dither-N_{f₂₀₀} may comprise the same dither signal introduced into the CH2, CH4, and CHN at different times. The second localized sequence may be somewhat similar to the first localized sequence, but may be localized to the node-2 620, rather than the node-1 610. The second localized sequences and may be communicated to the λ-locker_{f₂₀₀} 627 by the element manager 628 such that the λ-locker_{f₂₀₀} 627 can coordinate the detection of wavelength deviation in each of the CH2, the CH4, and the CHN with the sequential introduction of the Dither-2_{f₂₀₀}, the Dither-4_{f₂₀₀}, and the Dither-N_{f₂₀₀} (respectively) into the λ₂, the λ₄, and the λ_n (respectively). In an embodiment, the second localized sequence may not be related to the first localized sequence, and may not be communicated to any network components outside of node-2 620.

In other embodiments, the second localized sequence may be indirectly communicated to, but ignored by, remotely located network components such that the second localized sequence may be locally relevant to node-2 620, but may not be globally relevant, e.g., may not be used to synchronize wavelength locking in remote nodes.

The node-K 630 may comprise a TRX-1_{f_(k×100)} 631, a TRX-2_{f_(k×100)} 632, a TRX-P_{f_(k×100)} 635, a MUX 636, a λ-locker_{f_(k×100)} 637, an element manager 638, a DeMUX 639, and an RX-2 642, arranged as shown in FIG. 6. The node-K 630 may be configured somewhat similarly to the node-2 620 and/or the node-1 610. For instance, the node-K 630 may be configured to receive the second WDM signal (or a composite signal comprising at least some common wavelengths with the second WDM signal), drop the λ₂ from the second WDM signal, and add a λ₁', a λ₂', and a λ_p to the λ₃, the λ₄, the λ_m, and the λ_n to, e.g., with appropriate amplification, produce a third WDM signal. The components of node-3 630 may be configured somewhat similarly to the corresponding components of the node-2 620. In an embodiment, the DeMUX 639 may receive the second WDM signal, and demultiplex the second WDM signal into the λ₂, the λ₃, the λ₄, the λ_m, and the λ_n. The DeMUX 639 may forward the λ₂ to the RX-2 642, which may receive the λ₂ (e.g., thereby dropping the λ₂ from the second WDM signal). The DeMUX 639 may forward the λ₃, the λ₄, the λ_m, and the λ_n to the MUX 636. In an embodiment, the TRX-1_{f_(k×100)} 631, the TRX-2_{f_(k×100)} 632, and the TRX-P_{f_(k×100)} 635 may transmit the λ₁', the λ₂', and the λ_p in the CH1, the CH2, and a Pth channel (CHP), respectively, of the third WDM signal. Specifically, the λ₁' and the λ₂' may comprise the same wavelengths, but different data than the λ₁ and the λ₂. Hence, the node-K 630 may reuse the wavelengths associated with the λ₁ and λ₂. The MUX 637 may multiplex the λ₁', the λ₂', the λ_p, the λ₃, the λ₄, the λ_m, and the λ_n to produce the third WDM signal. In an embodiment, the TRX-1_{f_(k×100)} 631, the TRX-2_{f_(k×100)} 632, the TRX-P_{f_(k×100)} 635 may introduce a Dither-1_{f_(k×100)}, a Dither-2_{f_(k×100)}, and a dither signal corresponding to the CHP (Dither-P_{f_(k×100)}) into the λ₁', λ₂', and λ_p (respectively) according to a third localized sequence provided by the element manager 638, where each of the Dither-1_{f_(k×100)}, the Dither-2_{f_(k×100)}, and the Dither-P_{f_(k×100)} comprise the f_(k×100). In an embodiment, the Dither-1_{f_(k×100)}, the Dither-2_{f_(k×100)}, and the Dither-P_{f_(k×100)} may comprise the same dither signal introduced into the CH1, CH2, and CHP at different times. The third localized sequence may be substantially similar to the first localized sequence, and may be provided to the λ-locker_{f_(k×100)} 637 such that the detection of the wavelength drift in each of the λ₁', the λ₂', and the λ_n can be synchronized with the introduction of the Dither-1_{f_(k×100)}, the Dither-2_{f_(k×100)}, and the Dither-P_{f_(k×100)} (respectively). The λ-locker_{f_(k×100)} 637 may electronically filter a portion of the third WDM signal according to the f_(k×100), thereby isolating the λ₁', the λ₂', and the λ_p from the λ₃, the λ₄, the λ_m, and the λ_n. Subsequently, wavelength locking may be provided to the λ₁', the λ₂', and the λ_p by the λ-locker_{f_(k×100)} 637 and the element manager 638 according to the methods described above.

As demonstrated by the network architecture 600, the shared wavelength locking scheme may be easily scalable to large/complex networks, e.g., metro and/or regional optical networks. For instance, the nodes 610-630, as well as one or more intermediate nodes positioned between the node-2 620 and the node-K 630 (e.g., node-3, node-4, . . . node-(K-1)) may each be assigned a unique dither frequency (e.g., f₁₀₀, f₂₀₀, . . . f_(k×100)) such that wavelength locking can be completely localized. This may prevent conflicts between channels (e.g., or two channels comprising the same dither fre-

quency at the same time) such that the λ -lockers **617-637** can differentiate locally generated output signals from remotely generated output signals. One additional advantage is that new nodes may be added without reconfiguring existing nodes with respect to wavelength locking, and that additional channels can be added/removed in existing nodes without network-wide coordination. For instance, a network manager may add a node-(K+1) without disturbing wavelength locking in the nodes **610-630** by provisioning a new dither frequency (e.g., $f_{(k+1)\times 100}$). Additionally or alternatively, the node-K **630** may add a new channel (e.g., corresponding to a TRX-(p+1)) without needing to coordinate wavelength locking (e.g., frequencies, timeslots, etc.) with any other nodes in the network **600**, e.g., without requiring communication with a network manager regarding wavelength locking for the TRX-(p+1). Likewise, a channel and/or node can be removed without a substantial amount of network level coordination with respect to wavelength locking. Hence, the shared wavelength locking scheme may be well-suited for growing/evolving networks or networks that may be restructured in the future.

FIG. 7 illustrates an embodiment of a network architecture **700** for implementing a shared wavelength locking architecture. The network architecture may comprise a node-1 **710** and a node-2 **720**, configured as shown in FIG. 7. In an embodiment, the node-1 **710** and the node-2 **720** may be remotely located intermediate nodes, and may be configured similarly to the intermediate node **500** and/or one of the node-1 **610**, the node-2 **620**, or the node-K **630**. In an embodiment, the node-1 **710** may comprise a TRX-1_{f100} **701**, a TRX-3_{f100} **703**, a TRX-5_{f100} **705**, a TRX-7_{f100} **707**, a MUX **715**, a λ -locker_{f100} **716**, and an element manager **717**. In an embodiment, the TRX-1_{f100} **701**, the TRX-3_{f100} **703**, the TRX-5_{f100} **705**, and the TRX-7_{f100} **707** may be configured to transmit a λ_1 , a λ_3 , a λ_5 , and a λ_7 (respectively) down a CH1, a CH3, a CH5, and a CH7 (respectively) of a first WDM signal. In an embodiment, the TRX-1_{f100} **701**, the TRX-3_{f100} **703**, the TRX-5_{f100} **705**, and the TRX-7_{f100} **707** may introduce a Dither-1_{f100}, a Dither-3_{f100}, a Dither-5_{f100}, and a Dither-7_{f100} (respectively) into the λ_1 , the λ_3 , the λ_5 , and the λ_7 (respectively) according to a first localized sequence, e.g., a predetermined sequence that is localized to the node-1 **710**. The Dither-1_{f100}, the Dither-3_{f100}, the Dither-5_{f100}, and the Dither-7_{f100} may each comprise an f_{100} , which may be uniquely assigned to the node-1 **710**. In an embodiment, the Dither-1_{f100}, the Dither-3_{f100}, the Dither-5_{f100}, and the Dither-7_{f100} may comprise the same dither signal introduced into the CH1, CH3, a CH5, and a CH7 at different times. The MUX **715**, the λ -locker_{f100} **716**, and the element manager **717** may be configured similarly to the MUX **505**, the λ -locker_{f500} **506**, and the element manager **507**.

The node-2 **720** may comprise a TRX-2_{f200} **702**, a TRX-4_{f200} **704**, a TRX-6_{f200} **706**, a TRX-8_{f200} **708**, a MUX **725**, a λ -locker_{f200} **726**, an element manager **727**, and an interleaver **728**. The TRX-2_{f200} **702**, the TRX-4_{f200} **704**, the TRX-6_{f200} **706**, and the TRX-8_{f200} **708** may be configured to transmit a λ_2 , a λ_4 , a λ_6 , and a λ_8 (respectively) down a CH2, a CH4, a CH6, and a CH8 (respectively) of a second WDM signal. In an embodiment, TRX-2_{f200} **702**, the TRX-4_{f200} **704**, the TRX-6_{f200} **706**, and the TRX-8_{f200} **708** may introduce a Dither-2_{f200}, a Dither-4_{f200}, a Dither-6_{f200}, and a Dither-8_{f200} (respectively) into the λ_2 , the λ_4 , the λ_6 , and the λ_8 (respectively) according to an appropriate localized sequence, e.g., a predetermined sequence that is localized to the node-2 **720**. The Dither-2_{f200}, the Dither-4_{f200}, the Dither-6_{f200}, and the Dither-8_{f200} may each comprise an f_{200} , which may be uniquely assigned to node-2 **720**. In an embodiment, the

Dither-2_{f200}, the Dither-4_{f200}, the Dither-6_{f200}, and the Dither-8_{f200} may comprise the same dither signal introduced into the CH2, the CH4, the CH6, and the CH8 at different times. The MUX **725**, the λ -locker_{f200} **726**, and the element manager **727** may be configured similarly to the MUX **715**, the λ -locker_{f100} **716**, and the element manager **717**. The interleaver **728** may be any device used to combine two multiplexed WDM signals into a composited WDM signal. For instance, the interleaver **728** may comprise a 3-port optical device that is used to combine two sets of DWDM channels (e.g., odd and even channels) into a composite WDM signal stream. As used herein, composite WDM signals may refer to any WDM signal that comprises a wavelength, channel, or output signal that was previously carried in another WDM signal, and is not necessarily used only in the context of interleavers. For instance, the second WDM signal broadcast by the node-2 **620** may be considered as a composite WDM signal because it has at least one common output signal from the first WDM signal broadcast by the node-1 **610**.

In an embodiment, the composite WDM signal emitted from the interleaver **728** may comprise an optical spectrum **790**. The optical spectrum **790** may comprise a wavelength/channel spacing of about 200 GHz between even channels (e.g., 200 GHz between λ_2 and λ_4 , 200 GHz between λ_4 and λ_6 , and 200 GHz between λ_6 and λ_8), as well as a wavelength/channel spacing of about 200 GHz between odd channels (e.g., 200 GHz between λ_1 and λ_3 , 200 GHz between λ_3 and λ_5 , and 200 GHz between λ_5 and λ_7). In an embodiment, the optical spectrum **790** may comprise be a wavelength spacing of about 100 GHz between even and odd channels (e.g., 100 GHz between λ_1 and λ_2 , 100 GHz between λ_2 and λ_3 , . . . and 100 GHz between λ_7 and λ_8). In other embodiments, the channel spacing may vary (e.g., odd-odd and even-odd channel spacing of 100 GHz and 50 GHz respectively) The λ -locker_{f200} **726** may be configured to filter the composite WDM signal according to the f_{200} , and hence may provide wavelength locking to the output signals corresponding to the even channels (e.g., the λ_2 , the λ_4 , the λ_6 , and the λ_8), while ignoring the output signals corresponding to the odd channels (e.g., λ_1 , the λ_3 , the λ_5 , and the λ_7).

The shared wavelength locking scheme has been found to be effective in providing wavelength locking under some test scenarios. FIG. 8 illustrates a graph **800** that tracks wavelength locking in a test condition network architecture similar to the network architecture **700**. Notably, the test was conducted for twelve channels, although only eight channels are shown in herein for purposes of clarity and brevity. The Applicants submit that the results for wavelength locking in the other four channels (CH9 thru CH12, not shown) were substantially consistent with the results for wavelength locking for the eight channels discussed herein (CH1 thru CH8), and hence their inclusion herein would be duplicative. The graph **800** depicts changes in wavelength for output signals **801** corresponding with a plurality of channels (CH1 thru CH8) as an ambient temperature ($T_{ambient}$) **802** of the test condition network architecture was increased. In practice, changes in ambient temperature may cause, or significantly affect, wavelength drift in output signals because changing the operating conditions (e.g., operating temperature) of the laser transmitter substantially affects their ability to maintain a target wavelength. As shown, the output signal **801** maintained a delta wavelength of less than ± 1 GHz from their target wavelength as the $T_{ambient}$ **802** was varied at a rate of a 1.7° C. per minute. Hence, the shared wavelength locking scheme effectively provides wavelength locking even when the ambient temperature varies rapidly.

FIG. 9 illustrates a typical, general-purpose computer, suitable for implementing one or more embodiments of any component disclosed herein. The computer 900 includes a processor 902 (which may be referred to as a central processor unit or CPU) that is in communication with memory devices including secondary storage 904, read only memory (ROM) 906, random access memory (RAM) 908, input/output (I/O) devices 910, and network connectivity devices 912. The processor may be implemented as one or more CPU chips, or may be part of one or more application specific integrated circuits (ASICs).

The secondary storage 904 is typically comprised of one or more disk drives or tape drives and is used for non-volatile storage of data and as an over-flow data storage device if RAM 908 is not large enough to hold all working data. Secondary storage 904 may be used to store programs that are loaded into RAM 908 when such programs are selected for execution. The ROM 906 is used to store instructions and perhaps data that are read during program execution. ROM 906 is a non-volatile memory device that typically has a small memory capacity relative to the larger memory capacity of secondary storage 904. The RAM 908 is used to store volatile data and perhaps to store instructions. Access to both ROM 906 and RAM 908 is typically faster than access to secondary storage 904.

At least one embodiment is disclosed and variations, combinations, and/or modifications of the embodiment(s) and/or features of the embodiment(s) made by a person having ordinary skill in the art are within the scope of the disclosure. Alternative embodiments that result from combining, integrating, and/or omitting features of the embodiment(s) are also within the scope of the disclosure. Where numerical ranges or limitations are expressly stated, such express ranges or limitations may be understood to include iterative ranges or limitations of like magnitude falling within the expressly stated ranges or limitations (e.g., from about 1 to about 10 includes, 2, 3, 4, etc.; greater than 0.10 includes 0.11, 0.12, 0.13, etc.). For example, whenever a numerical range with a lower limit, R_l , and an upper limit, R_u , is disclosed, any number falling within the range is specifically disclosed. In particular, the following numbers within the range are specifically disclosed: $R=R_l+k*(R_u-R_l)$, wherein k is a variable ranging from 1 percent to 100 percent with a 1 percent increment, i.e., k is 1 percent, 2 percent, 3 percent, 4 percent, 5 percent, . . . , 50 percent, 51 percent, 52 percent, . . . , 95 percent, 96 percent, 97 percent, 98 percent, 99 percent, or 100 percent. Moreover, any numerical range defined by two R numbers as defined in the above is also specifically disclosed. Use of the term "optionally" with respect to any element of a claim means that the element is required, or alternatively, the element is not required, both alternatives being within the scope of the claim. Use of broader terms such as comprises, includes, and having may be understood to provide support for narrower terms such as consisting of, consisting essentially of, and comprised substantially of. Accordingly, the scope of protection is not limited by the description set out above but is defined by the claims that follow, that scope including all equivalents of the subject matter of the claims. Each and every claim is incorporated as further disclosure into the specification and the claims are embodiment(s) of the present disclosure. The discussion of a reference in the disclosure is not an admission that it is prior art, especially any reference that has a publication date after the priority date of this application. The disclosure of all patents, patent applications, and publications cited in the disclosure are hereby

incorporated by reference, to the extent that they provide exemplary, procedural, or other details supplementary to the disclosure.

While several embodiments have been provided in the present disclosure, it may be understood that the disclosed systems and methods might be embodied in many other specific forms without departing from the spirit or scope of the present disclosure. The present examples are to be considered as illustrative and not restrictive, and the intention is not to be limited to the details given herein. For example, the various elements or components may be combined or integrated in another system or certain features may be omitted, or not implemented.

In addition, techniques, systems, subsystems, and methods described and illustrated in the various embodiments as discrete or separate may be combined or integrated with other systems, modules, techniques, or methods without departing from the scope of the present disclosure. Other items shown or discussed as coupled or directly coupled or communicating with each other may be indirectly coupled or communicating through some interface, device, or intermediate component whether electrically, mechanically, or otherwise. Other examples of changes, substitutions, and alterations are ascertainable by one skilled in the art and may be made without departing from the spirit and scope disclosed herein.

What is claimed is:

1. An apparatus comprising:

at least one processor configured to:

receive a wavelength division multiplexed (WDM) signal from a remote node, wherein the WDM signal comprises a first channel carrying a first remotely generated signal, a second channel carrying a second remotely generated signal, and a third channel;

adapt the WDM signal into a composite WDM signal by: dropping the first remotely generated signal from the first channel; adding a first locally generated signal to the first channel; and adding a second locally generated signal to the third channel; and

provide wavelength locking to the first locally generated signal and the second locally generated signal without providing wavelength locking to the second remotely generated signal based on a dither frequency associated with the apparatus.

2. The apparatus of claim 1, wherein the remote node is associated with a first unique dither frequency, wherein the dither frequency associated with the apparatus is a second unique dither frequency, and wherein the first unique dither frequency is not the same as the second unique dither frequency.

3. The apparatus of claim 2, wherein the second remotely generated signal comprises a first dither signal, but not a second dither signal,

wherein the first locally generated signal and the second locally generated signal comprise the second dither signal, but not the first dither signal,

wherein the first dither signal comprises the first unique dither frequency, but not the second dither frequency, and

wherein the second dither signal comprises the second unique dither frequency, but not the first dither frequency.

4. The apparatus of claim 3, wherein the second dither signal is sequentially introduced into the first locally generated signal and the second locally generated signal such that the first locally generated signal and the second locally generated signal never comprise the second dither signal at the same time.

21

5. The apparatus of claim 3, wherein the second dither signal is introduced into the first locally generated signal and the second locally generated signal according to a first time-division-multiplexed (TDM) window such that:

the second dither signal is applied to the first locally generated signal during a first time slot, but not during a second timeslot; and

the second dither signal is applied to the second locally generated signal during the second timeslot, but not during the first timeslot, and

wherein the first TDM window is localized to the apparatus such that the apparatus does not communicate the first TDM window to the remote node or any other network component that is not located within the apparatus.

6. The apparatus of claim 5, wherein wavelength locking is provided to the first remotely generated signal and the second remotely generated signal by the remote node according to a second TDM window such that the first remotely generated signal and the second remotely generated signal never comprise the first dither signal at the same time, and

wherein the second TDM window is localized to the remote node such that the remote node does not communicate the second TDM window to the apparatus or to any other network component that is not located within the remote node.

7. The apparatus of claim 6, wherein the first TDM window and the second TDM window are not synchronized with one another.

8. The apparatus of claim 1, wherein the at least one processor is further configured to forward the composite WDM signal to a second remote node that is located remotely from both the remote node and the apparatus.

9. An apparatus comprising:

a first transponder configured to generate a first optical signal;

a second transponder configured to generate a second optical signal;

an optical fiber configured to propagate a third optical signal, wherein the third optical signal is not generated by the apparatus;

an optical multiplexer configured to combine the first optical signal, the second optical signal, and the third optical signal into a composite wavelength division multiplexed (WDM) optical signal; and

a wavelength locker configured to wavelength lock the first optical signal and the second optical signal, but not the third optical signal,

wherein the first optical signal and the second optical signal are wavelength locked using a first dither frequency that is different than a second dither frequency used to lock the third optical signal, and

wherein the first optical signal and the second optical signal share the first dither frequency using a time division multiplexing (TDM) wavelength locking scheme that is localized to the apparatus.

10. The apparatus of claim 9, wherein the apparatus comprises only one wavelength locker.

11. The apparatus of claim 9, wherein the wavelength locker is located on a fiber output of the optical multiplexer.

12. The apparatus of claim 9 further comprising an optical demultiplexer configured to:

receive a WDM signal comprising the third optical signal and at least one other optical signal;

demultiplex the WDM signal to separate the third optical signal from the at least one other optical signal; and forward the third optical signal on the optical fiber.

22

13. The apparatus of claim 12, wherein the optical demultiplexer is coupled to the optical fiber, and wherein optical fiber extends from the optical demultiplexer to the optical multiplexer.

14. The apparatus of claim 13 further comprising an optical amplifier coupled to the optical demultiplexer and configured to amplify the WDM signal before the WDM signal is received by the optical demultiplexer.

15. A method comprising:

assigning, by a network manager, a first dither frequency to a first intermediate node in a network and a second dither frequency to a second intermediate node in the network, wherein the first dither frequency is different than the second dither frequency;

providing, by the first intermediate node, wavelength locking to a first plurality of optical signals in a first wavelength division multiplexed (WDM) signal, wherein the first plurality of optical signals are generated by the first intermediate node and comprise the first dither frequency, but not the second dither frequency;

providing, by the second intermediate node, wavelength locking to a second plurality of optical signals in a composite WDM signal that comprises both the second plurality of optical signals and at least some of the first plurality of optical signals,

wherein the second plurality of optical signals are generated by the second intermediate node and comprise the second dither frequency, but not the first dither frequency, and

wherein providing wavelength locking to the second plurality of optical signals comprises isolating the second plurality of optical signals from the first plurality of optical signals by electronically filtering, at the second intermediate node, a portion of the composite WDM signal according to the second dither frequency; and

transmitting, by the second intermediate node, the composite WDM signal to a third intermediate node.

16. The method of claim 15, wherein the first intermediate node provides wavelength locking to the first plurality of optical signals according to a first time-division-multiplexed (TDM) wavelength locking scheme that is localized to the first intermediate node, and

wherein the second intermediate node provides wavelength locking to the second plurality of optical signals according to a second TDM wavelength locking scheme that is localized to the second intermediate node.

17. The method of claim 16, wherein the first TDM wavelength locking scheme comprises sequentially introducing a first dither signal comprising the first dither frequency into each of the first plurality of optical signals according to a first TDM window,

wherein the first TDM window comprises a first plurality of timeslots,

wherein a unique one of the first plurality of timeslots is assigned to each of the first plurality of optical signals such that no two optical signals are assigned the same timeslot, and

wherein none of the first plurality of timeslots is assigned to any of the second plurality of optical signals.

18. The method of claim 17, wherein the second TDM wavelength locking scheme comprises sequentially introducing a second dither signal comprising the second dither frequency into each of the second plurality of optical signals according to a second TDM window comprising a second plurality of timeslots,

wherein a unique one of the second plurality of timeslots is assigned to each of the second plurality of optical signals,

wherein none of the second plurality of timeslots is assigned to any of the first plurality of optical signals, 5

wherein the first intermediate node does not have access to the second TDM window, and

wherein the second intermediate node does not have access to the first TDM window.

19. The method of claim **15** further comprising: adding, by 10 the network manager, a third intermediate node to the network subsequent to an initialization of, and communication between, the first intermediate node and the second intermediate node,

wherein adding a third intermediate node comprises 15 assigning a third dither frequency to the third intermediate node,

wherein the third dither frequency is different than both the second dither frequency and the first dither frequency,

wherein, after being added to the network, the third intermediate node provides wavelength locking to at least 20 one output signal generated locally within the third intermediate node, and

wherein the third intermediate node is added to the network without modifying any aspect or characteristic of the 25 wavelength locking in the first intermediate node and the second intermediate node.

* * * * *