

US008766104B2

(12) **United States Patent**  
**Moul et al.**

(10) **Patent No.:** **US 8,766,104 B2**  
(45) **Date of Patent:** **Jul. 1, 2014**

(54) **PRINTED CIRCUIT BOARDS INCLUDING STRIP-LINE CIRCUITRY AND METHODS OF MANUFACTURING SAME**

(75) Inventors: **Wayne L. Moul**, Loveland, CO (US);  
**Robert J. Behnke, II**, Erie, CO (US);  
**Scott E. M. Frushour**, Boulder, CO (US);  
**Jeffrey L. Jensen**, Boulder, CO (US)

(73) Assignee: **Covidien LP**, Mansfield, MA (US)

(\*) Notice: Subject to any disclaimer, the term of this patent is extended or adjusted under 35 U.S.C. 154(b) by 86 days.

(21) Appl. No.: **13/352,909**

(22) Filed: **Jan. 18, 2012**

(65) **Prior Publication Data**

US 2013/0180762 A1 Jul. 18, 2013

(51) **Int. Cl.**

**H05K 1/16** (2006.01)

**H05K 1/18** (2006.01)

**H05K 3/46** (2006.01)

(52) **U.S. Cl.**

CPC ..... **H05K 1/183** (2013.01); **H05K 3/4694** (2013.01)

USPC ..... **174/260**; 361/761

(58) **Field of Classification Search**

CPC ..... H05K 1/183; H05K 1/46943

USPC ..... 361/761-764; 174/260; 29/846-854

See application file for complete search history.

(56) **References Cited**

**U.S. PATENT DOCUMENTS**

4,898,540 A 2/1990 Saito  
4,901,039 A 2/1990 Corzine et al.  
5,028,896 A 7/1991 Kuokkanen  
6,066,386 A 5/2000 Boyko et al.  
6,137,237 A 10/2000 MacLennan et al.

6,225,756 B1 5/2001 Gitsevich  
6,313,587 B1 11/2001 MacLennan et al.  
6,329,603 B1 12/2001 Japp et al.  
6,535,085 B2 3/2003 Song et al.  
6,900,986 B2\* 5/2005 Kimoto et al. .... 361/704  
6,949,887 B2 9/2005 Kirkpatrick et al.  
7,400,214 B2 7/2008 Storniolo et al.  
7,561,006 B2 7/2009 Dutta  
7,982,560 B2 7/2011 Hesselbarth  
8,218,337 B2\* 7/2012 Choudhury et al. .... 361/818  
8,400,776 B2\* 3/2013 Sahara et al. .... 361/765  
2009/0009261 A1 1/2009 Song  
2009/0112200 A1 4/2009 Eggers  
2010/0052993 A1 3/2010 Kim  
2010/0171574 A1 7/2010 Sakiyama et al.

**FOREIGN PATENT DOCUMENTS**

KR 10-2005-0027461 A 3/2005

**OTHER PUBLICATIONS**

PCT International Search Report dated Apr. 29, 2013 for PCT/US2013/021706.

\* cited by examiner

*Primary Examiner* — Jeremy C Norris

(57) **ABSTRACT**

A multi-layer printed circuit board includes a first layer stack and a second layer stack coupled to the first layer stack. The first layer stack includes a first electrically-insulating layer, a second electrically-insulating layer, and a first electrically-conductive layer disposed between the first and second electrically-insulating layers. The second layer includes a third electrically-insulating layer and a second electrically-conductive layer. The first layer stack and/or the second layer stack include a cut-out area defining a void that extends therethrough. The multi-layer printed circuit board further includes a first signal layer disposed in association with the first electrically-insulating layer of the first layer stack or the third electrically-insulating layer of the second layer stack, a second signal layer disposed in association with the second electrically-insulating layer of the first layer stack, and a device at least partially disposed within the cut-out area and electrically-coupled to the first and second signal layers.

**13 Claims, 21 Drawing Sheets**

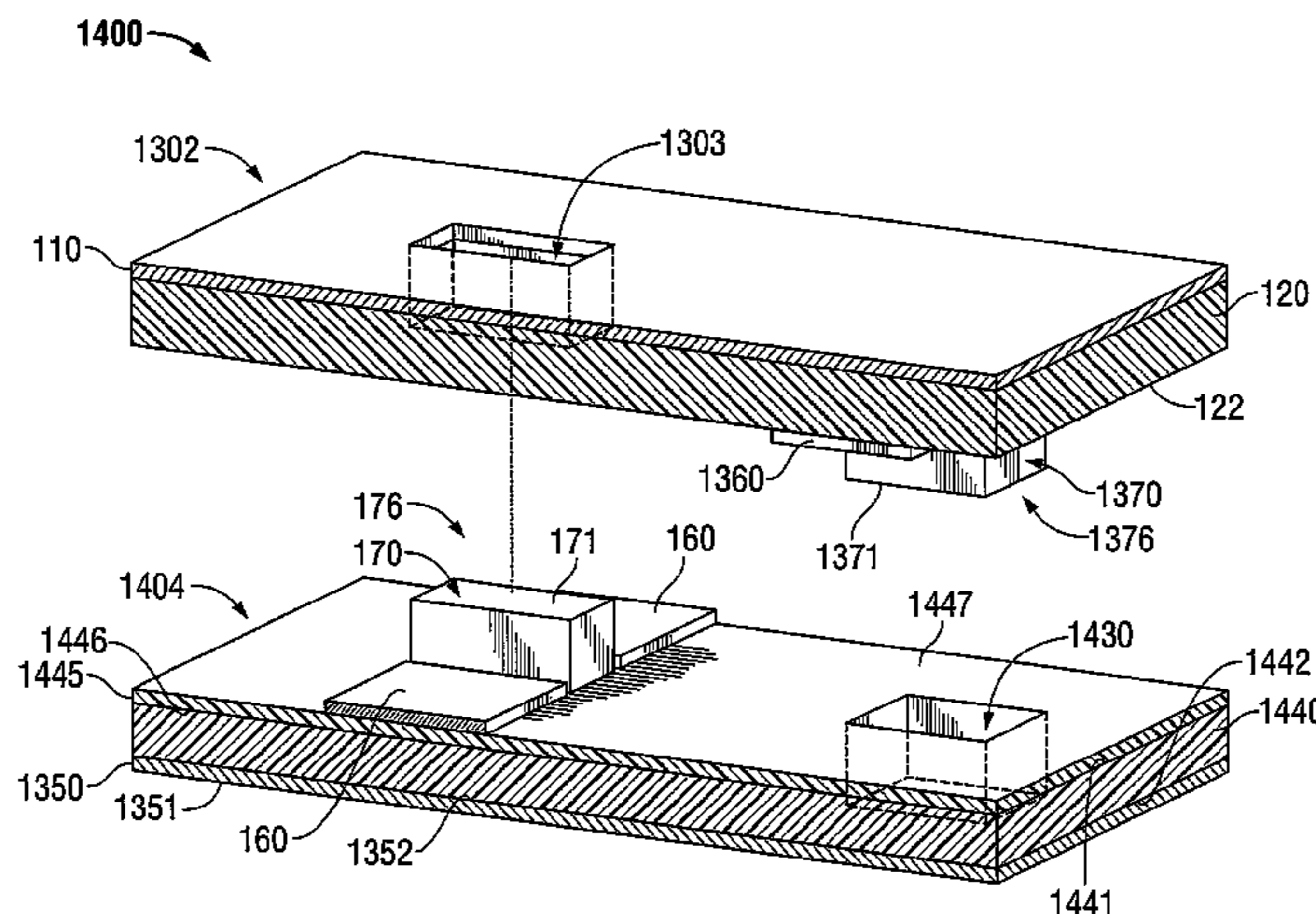

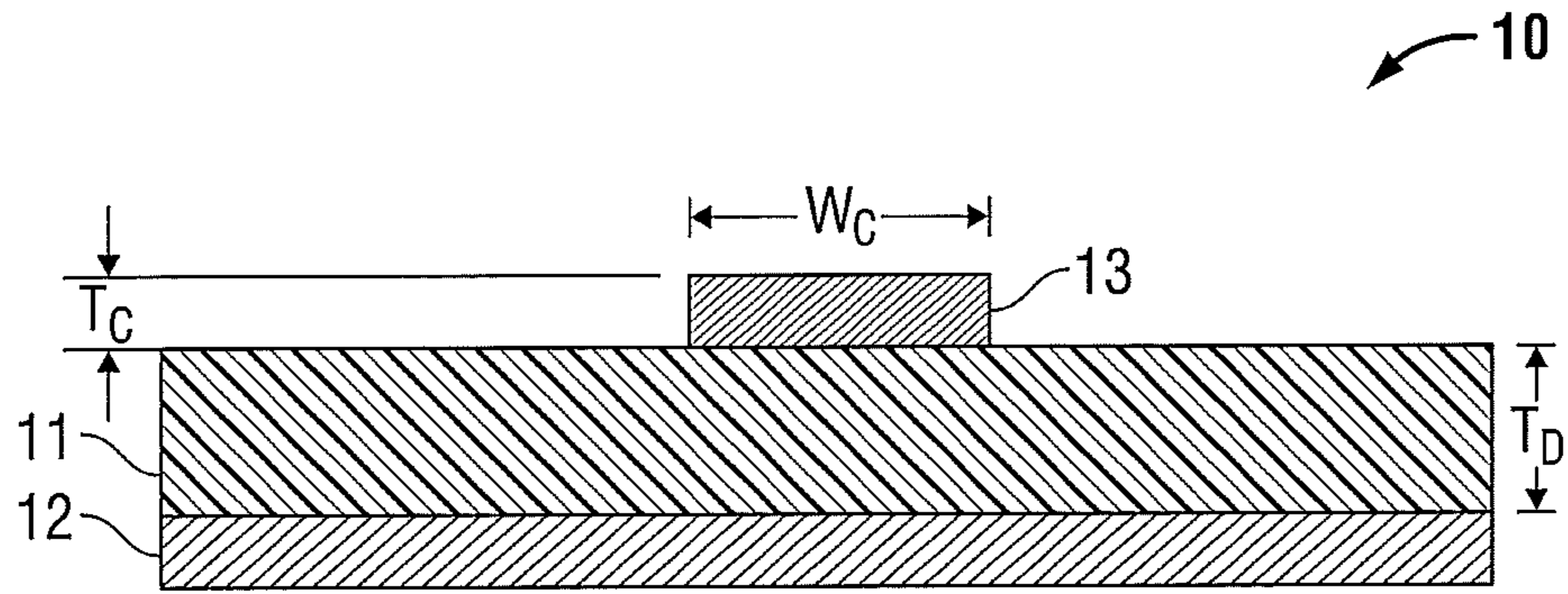

**FIG. 1**  
**(Prior Art)**

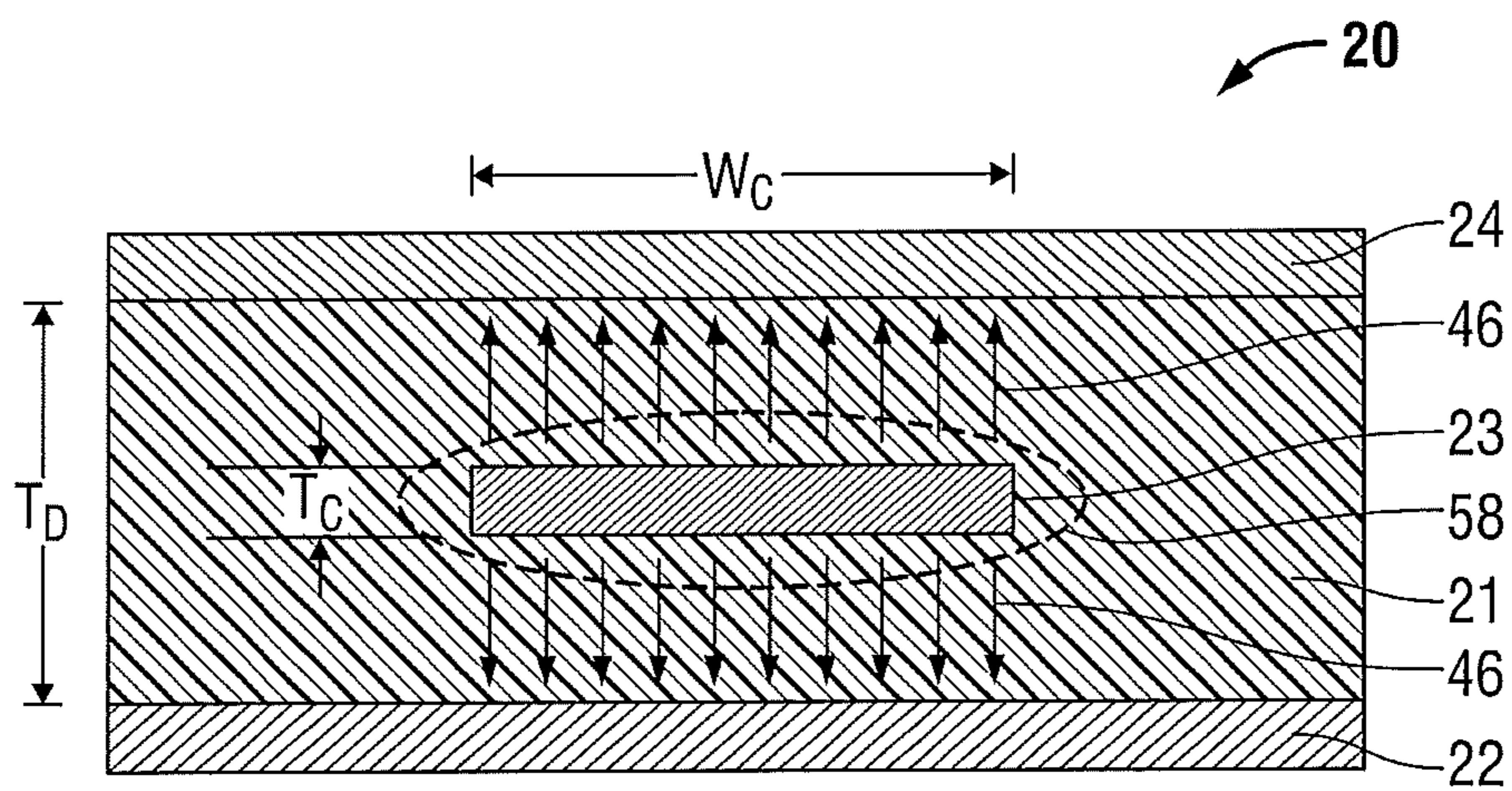

**FIG. 2**  
**(Prior Art)**

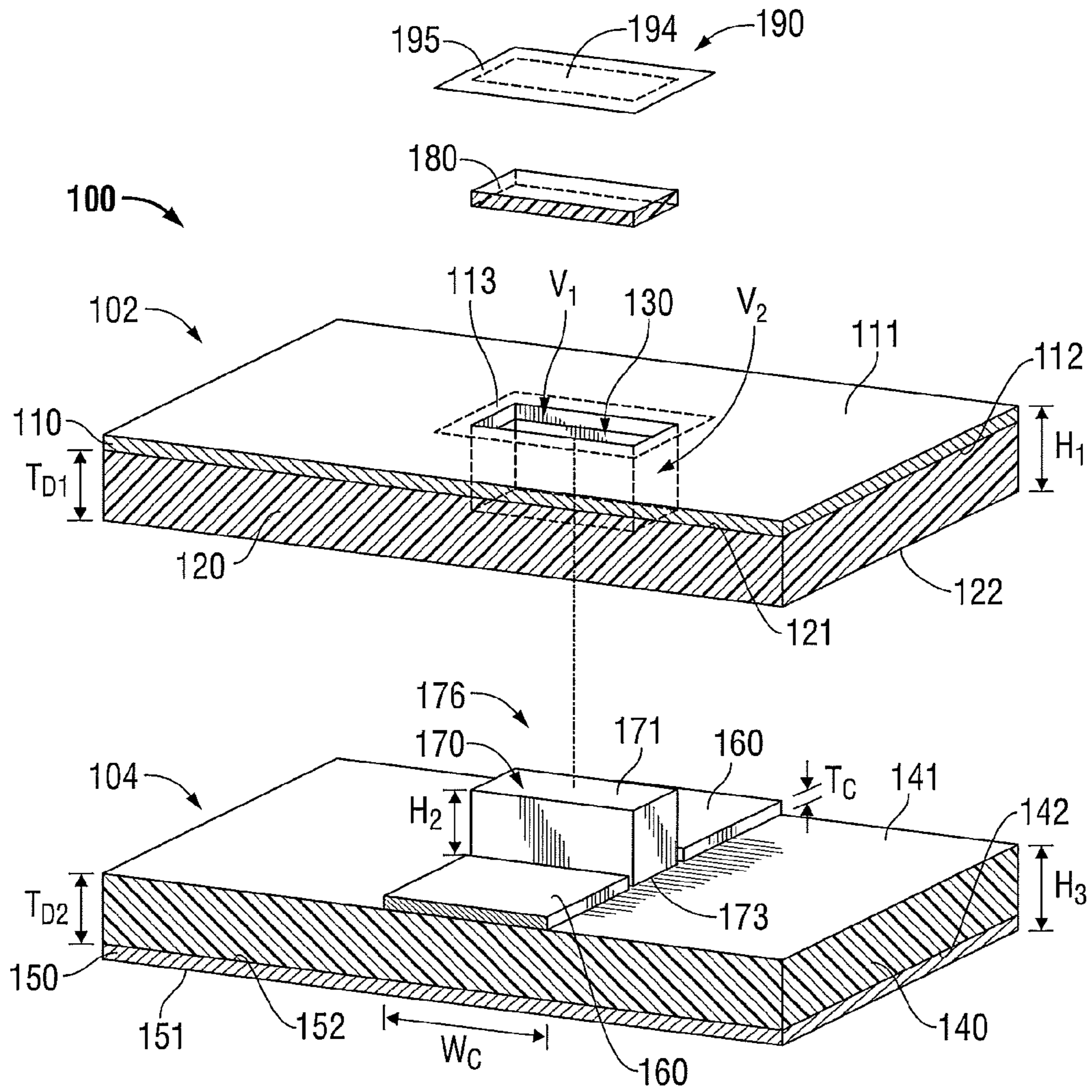

FIG. 3

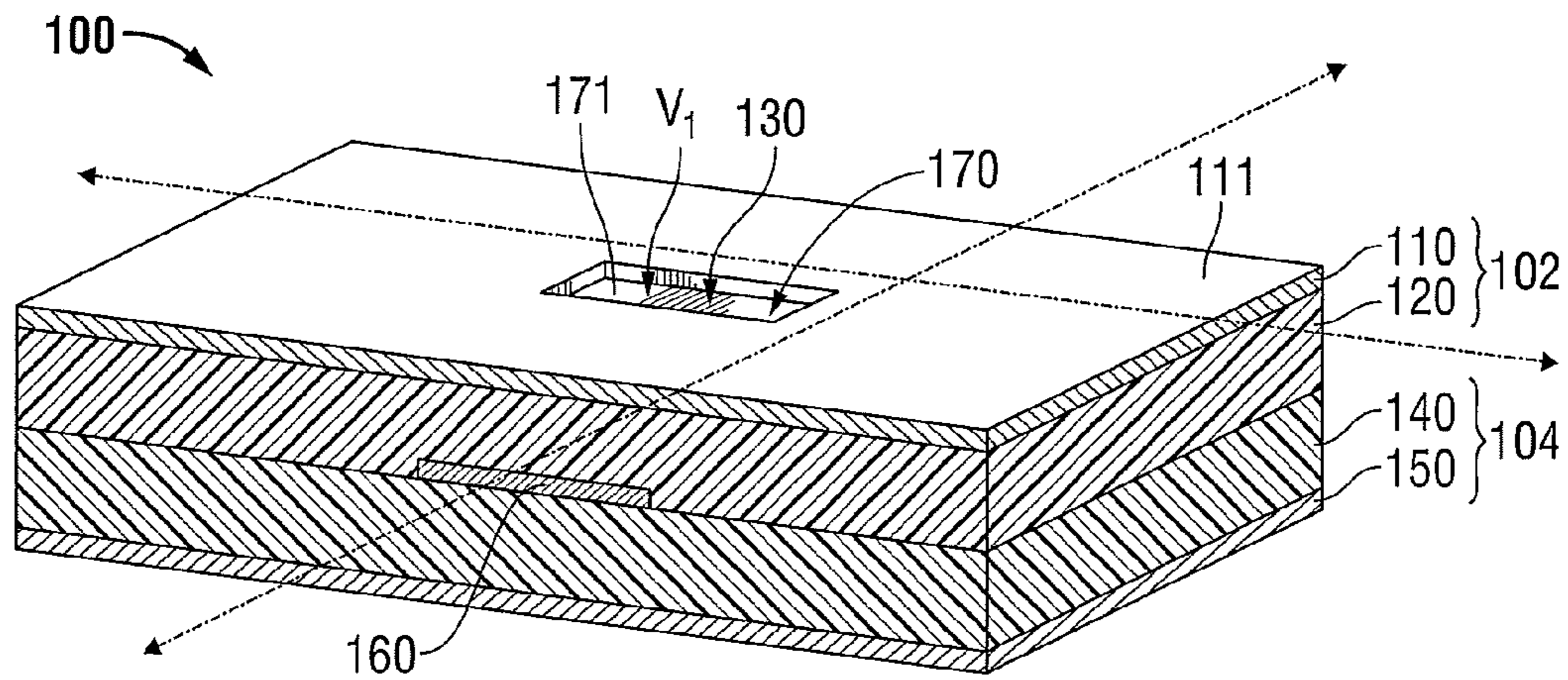

FIG. 4

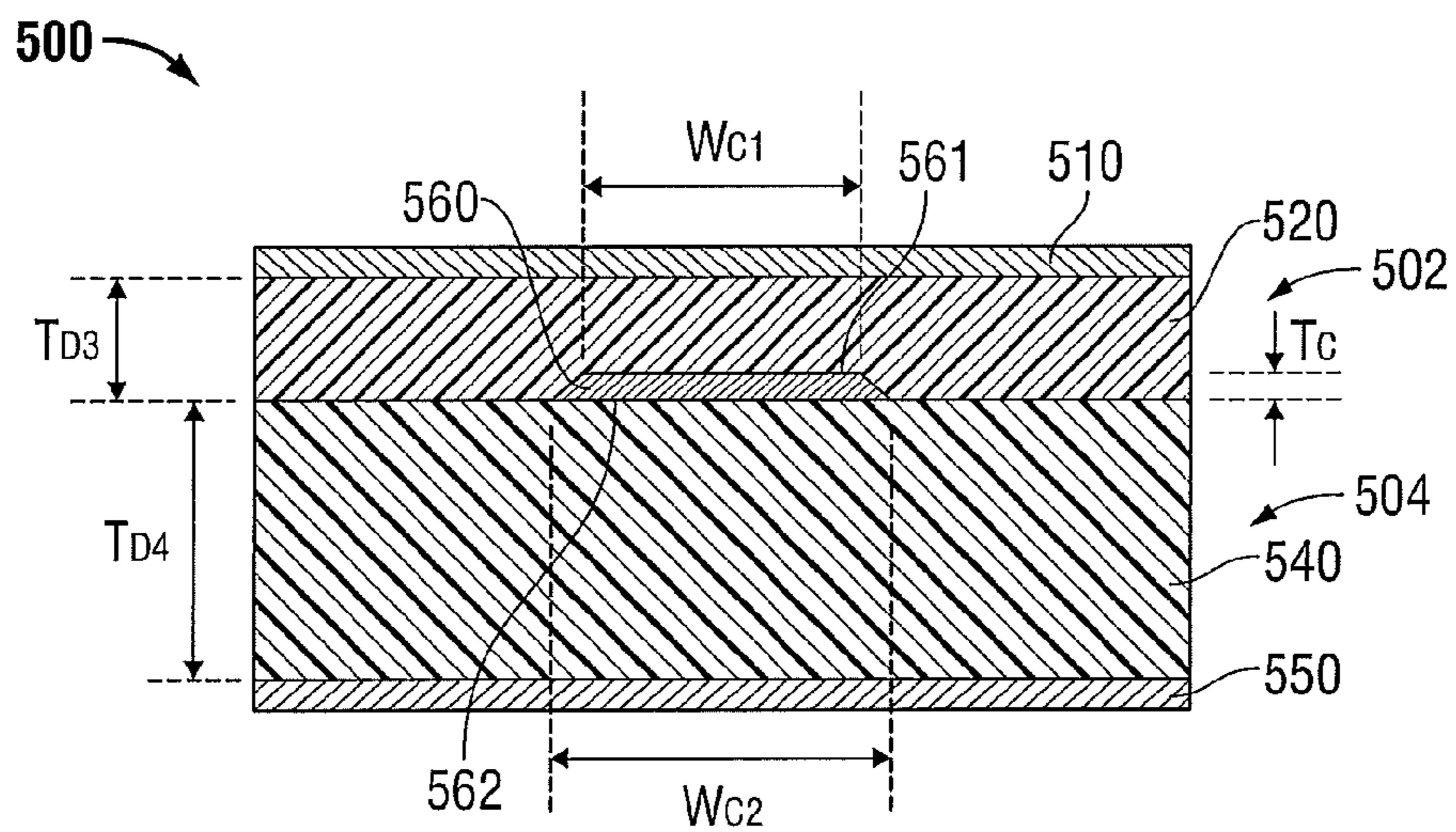

FIG. 5

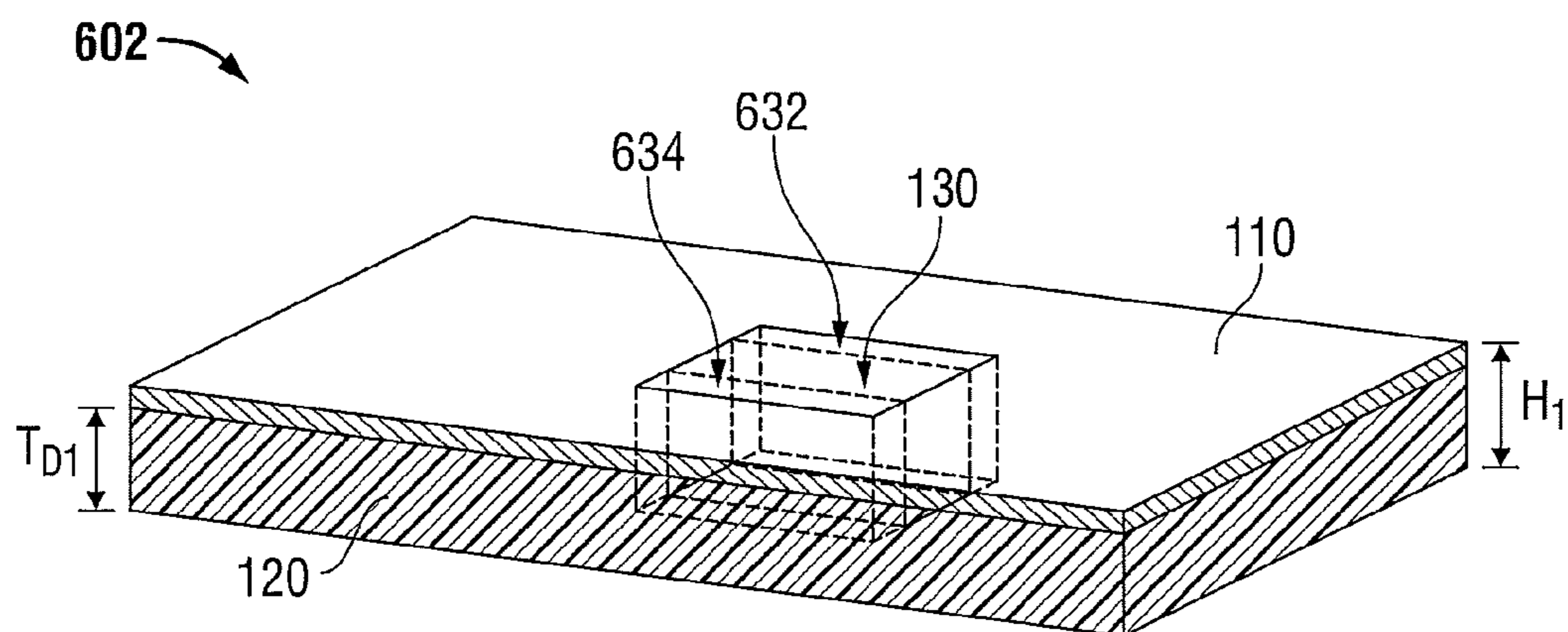

FIG. 6

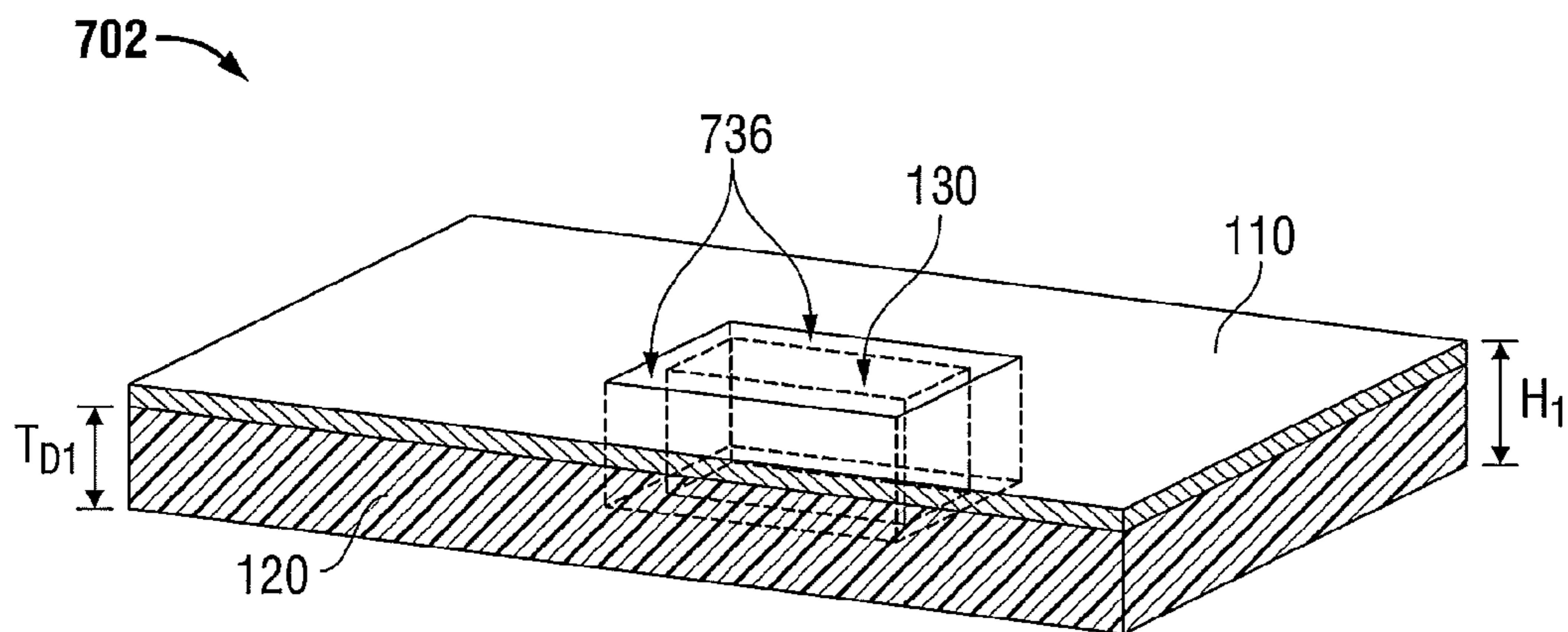

FIG. 7

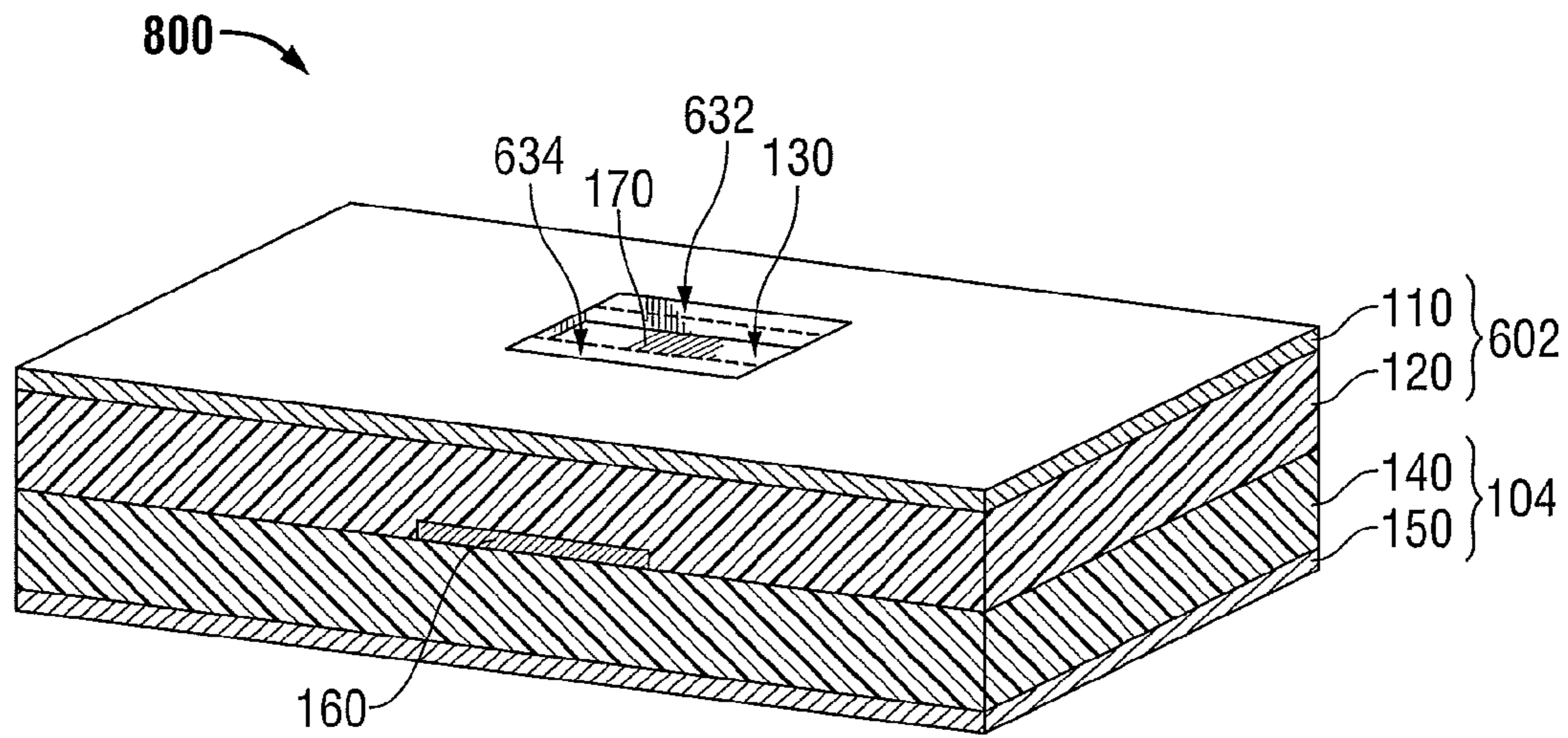

FIG. 8

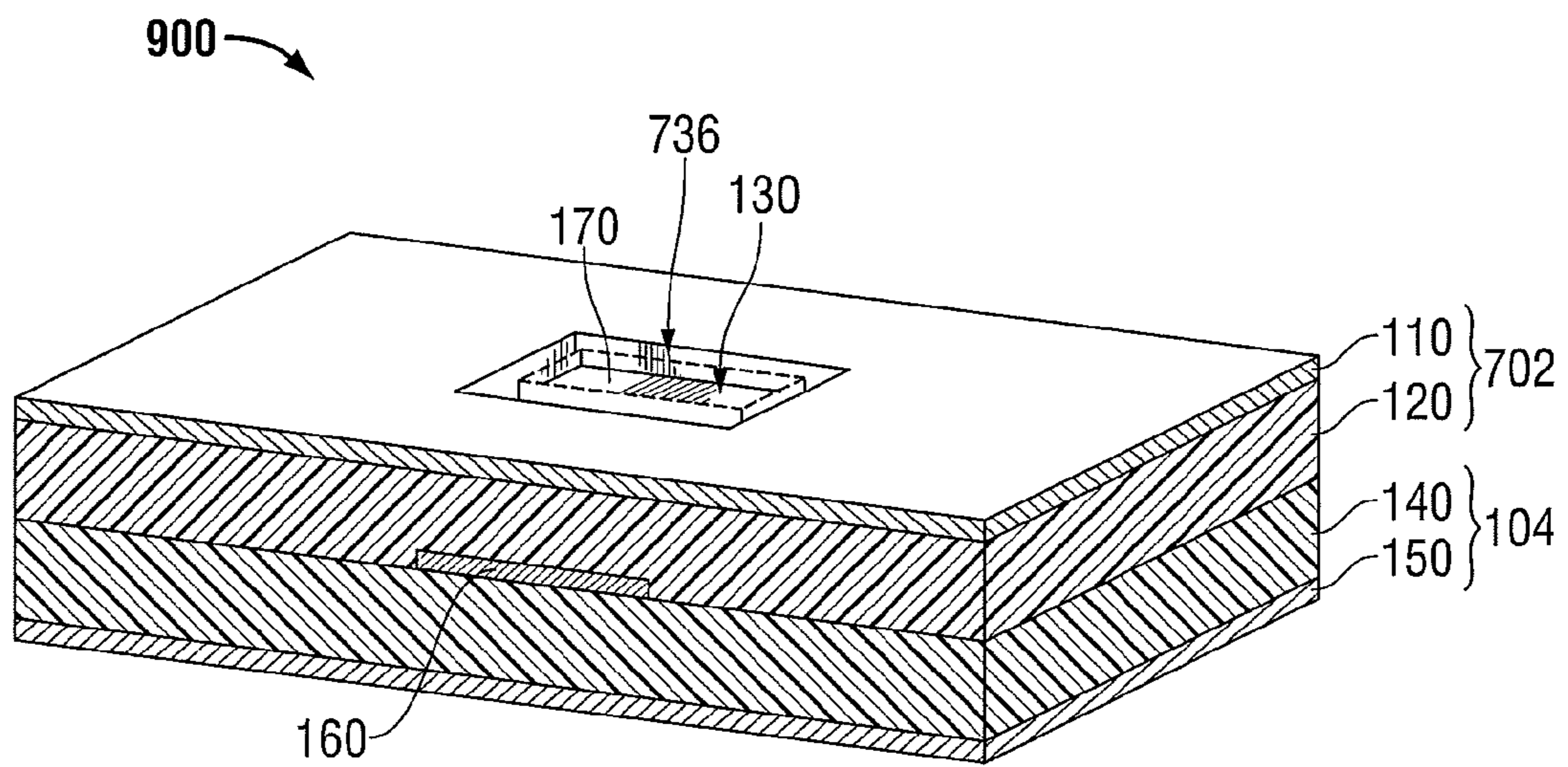

FIG. 9

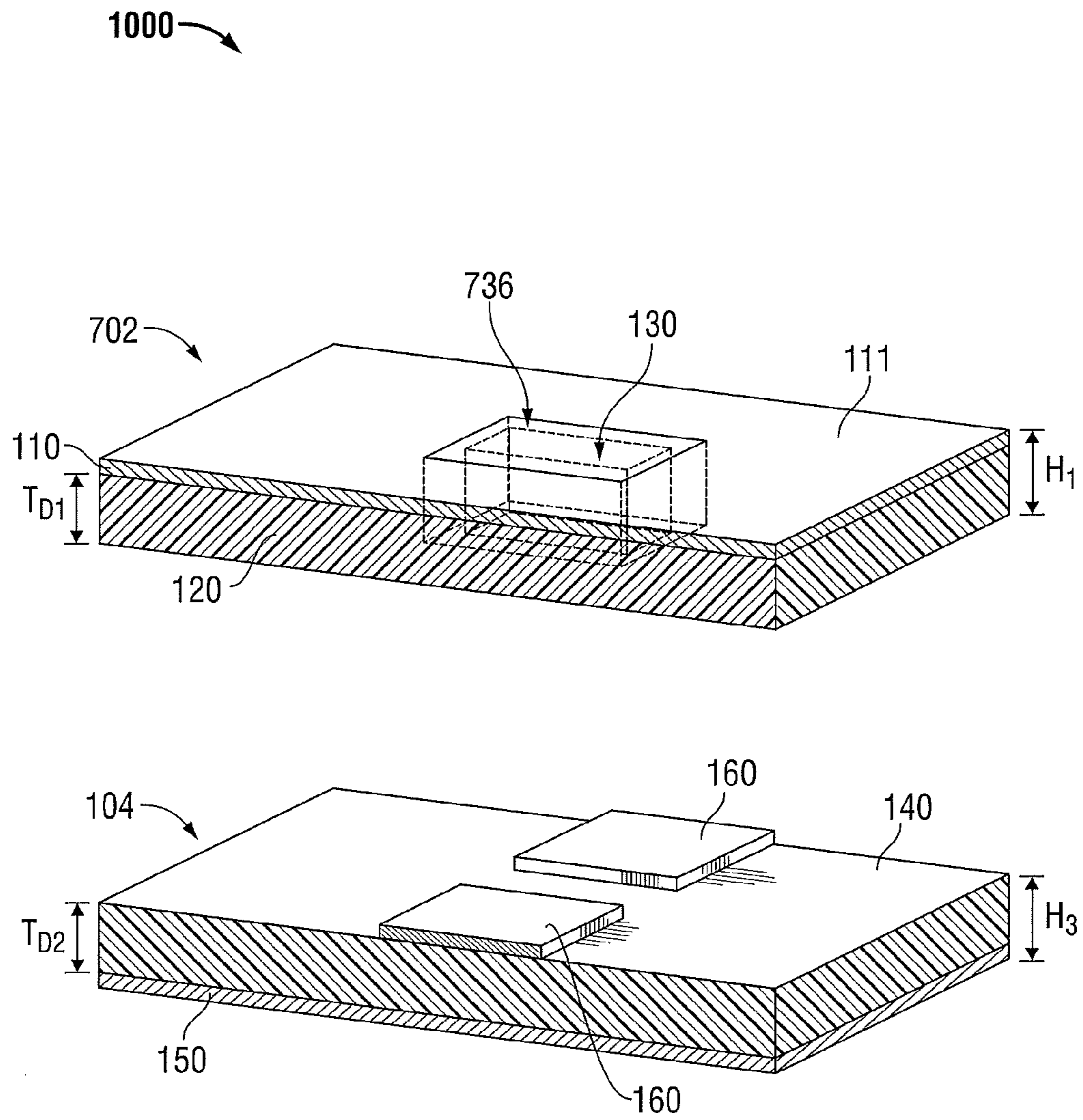

FIG. 10A

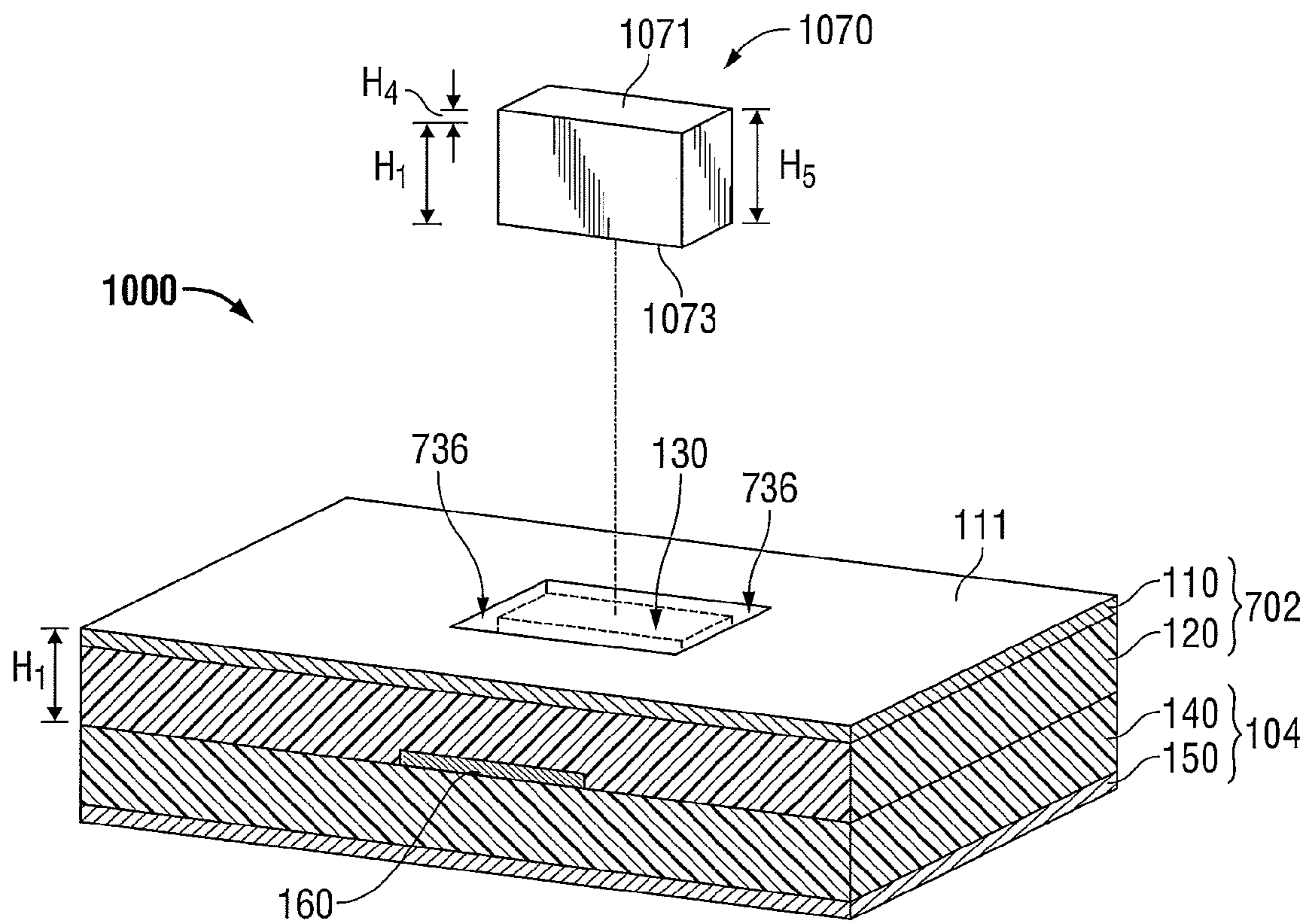

FIG. 10B



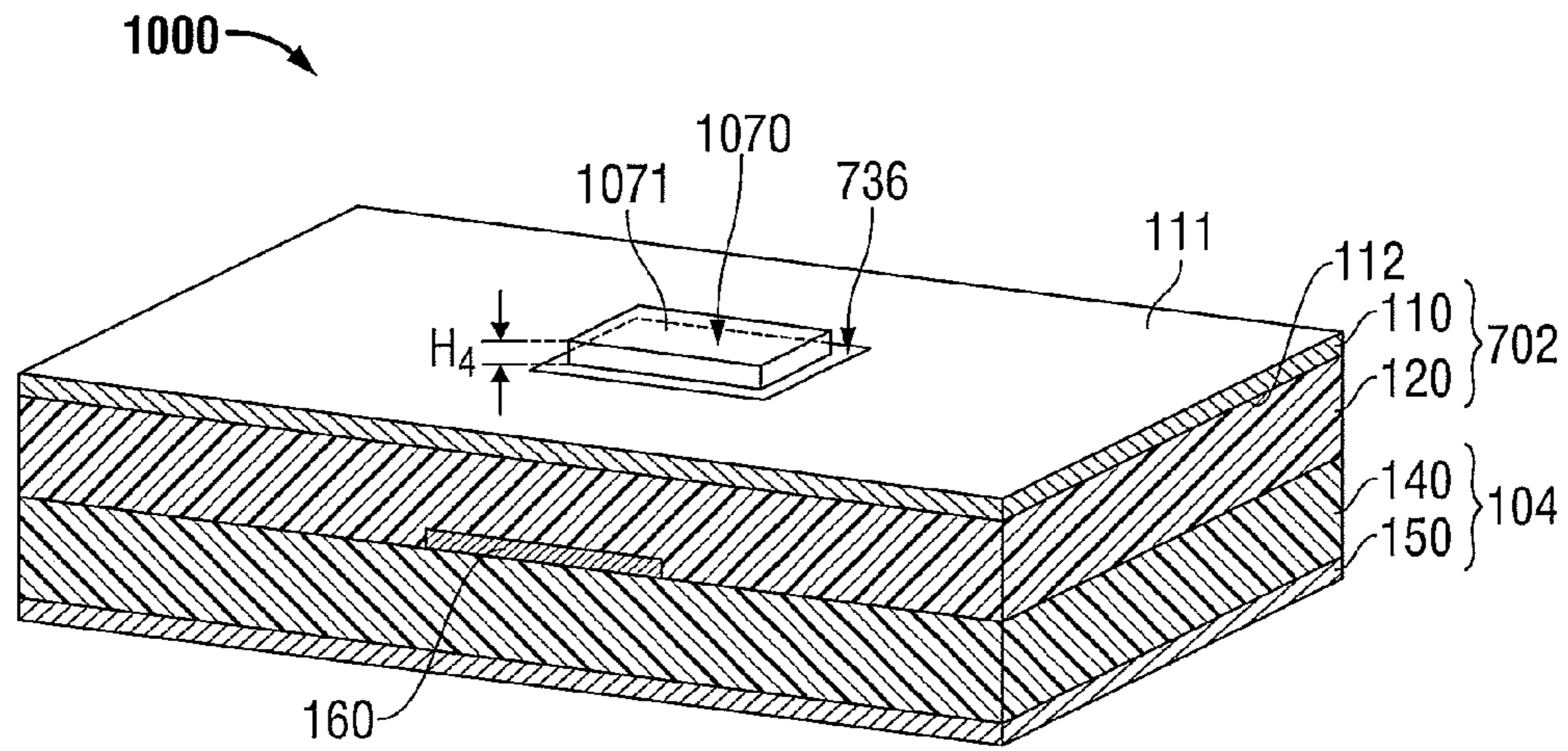

FIG. 10C

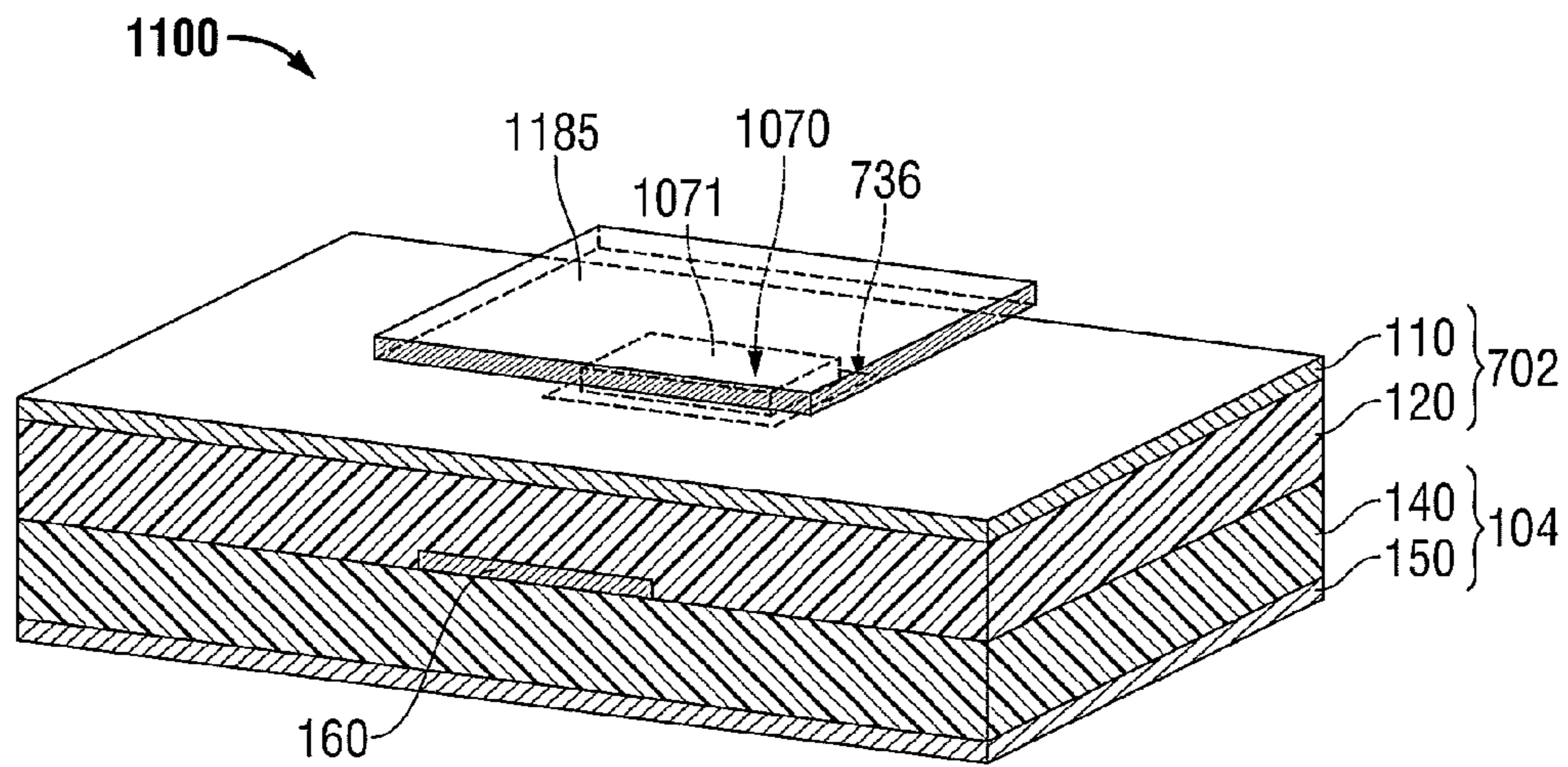

FIG. 11

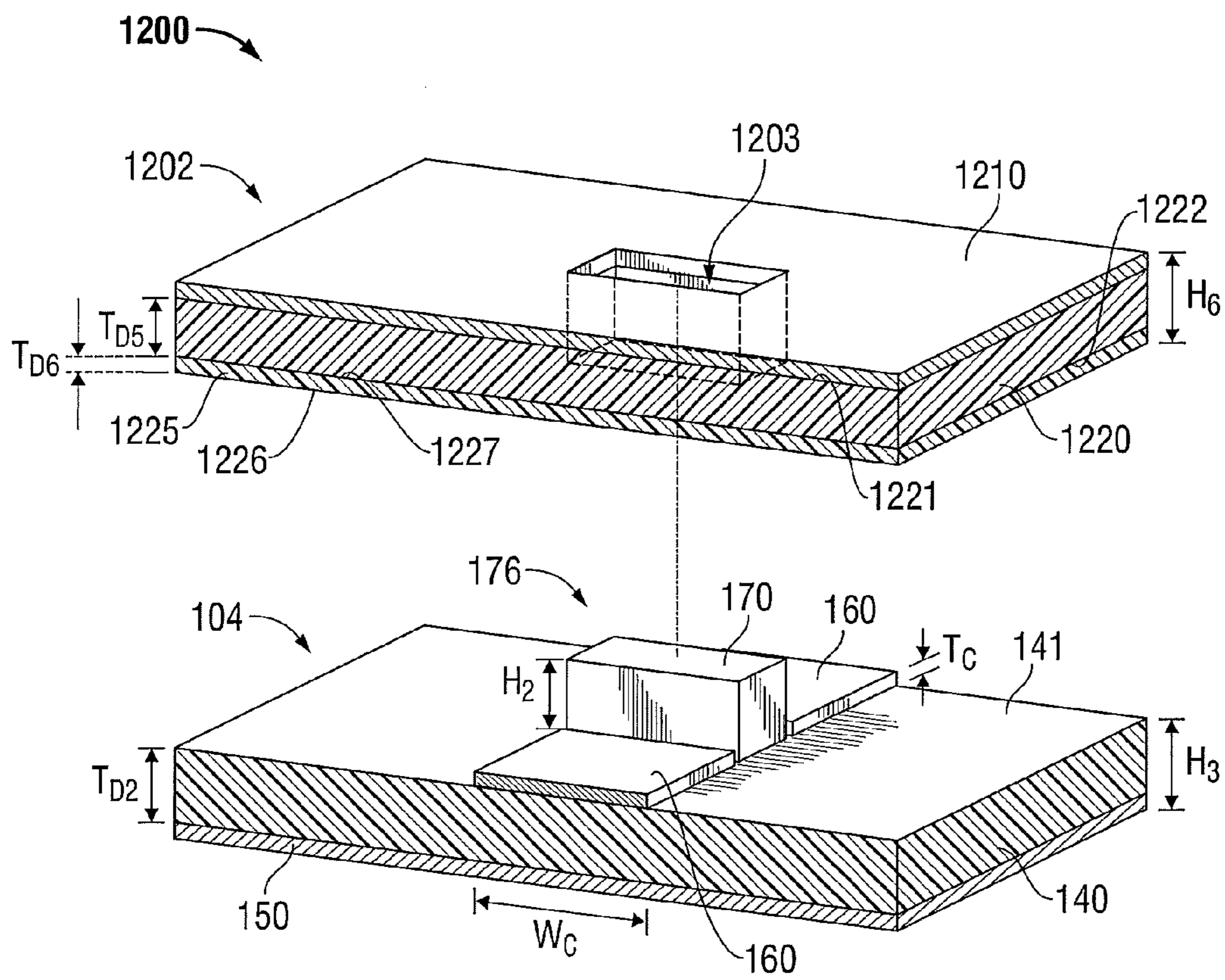

FIG. 12

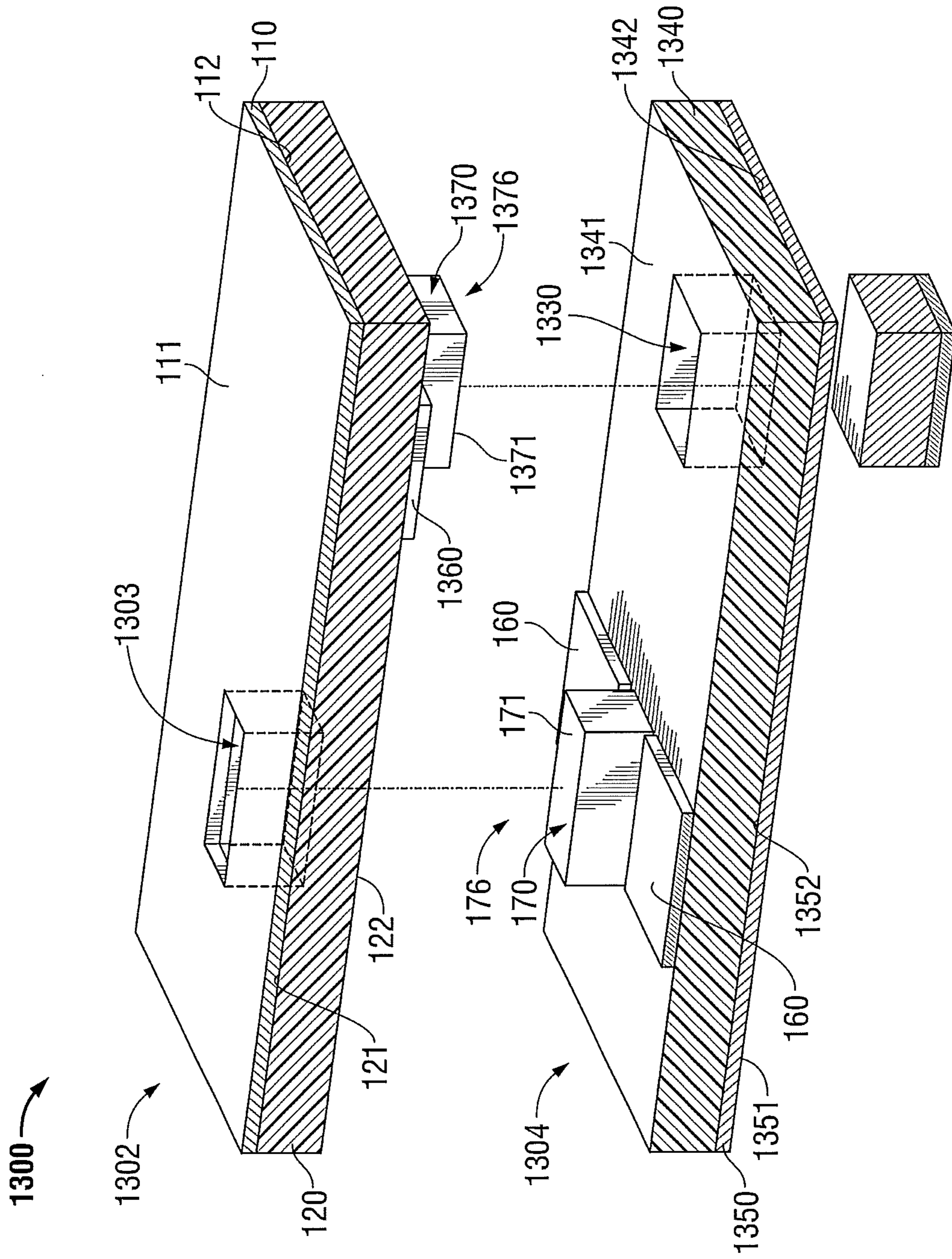

FIG. 13

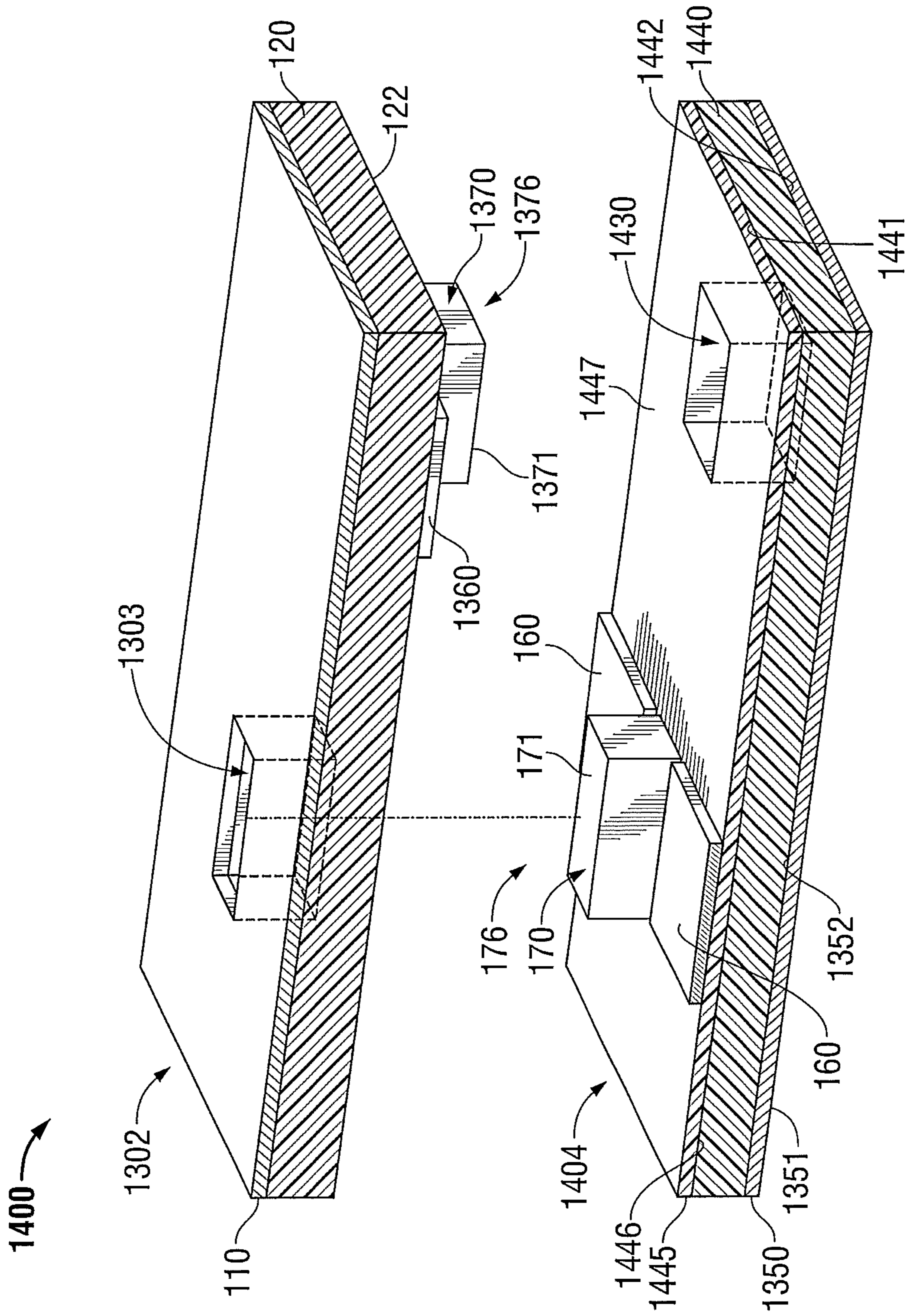

FIG. 14

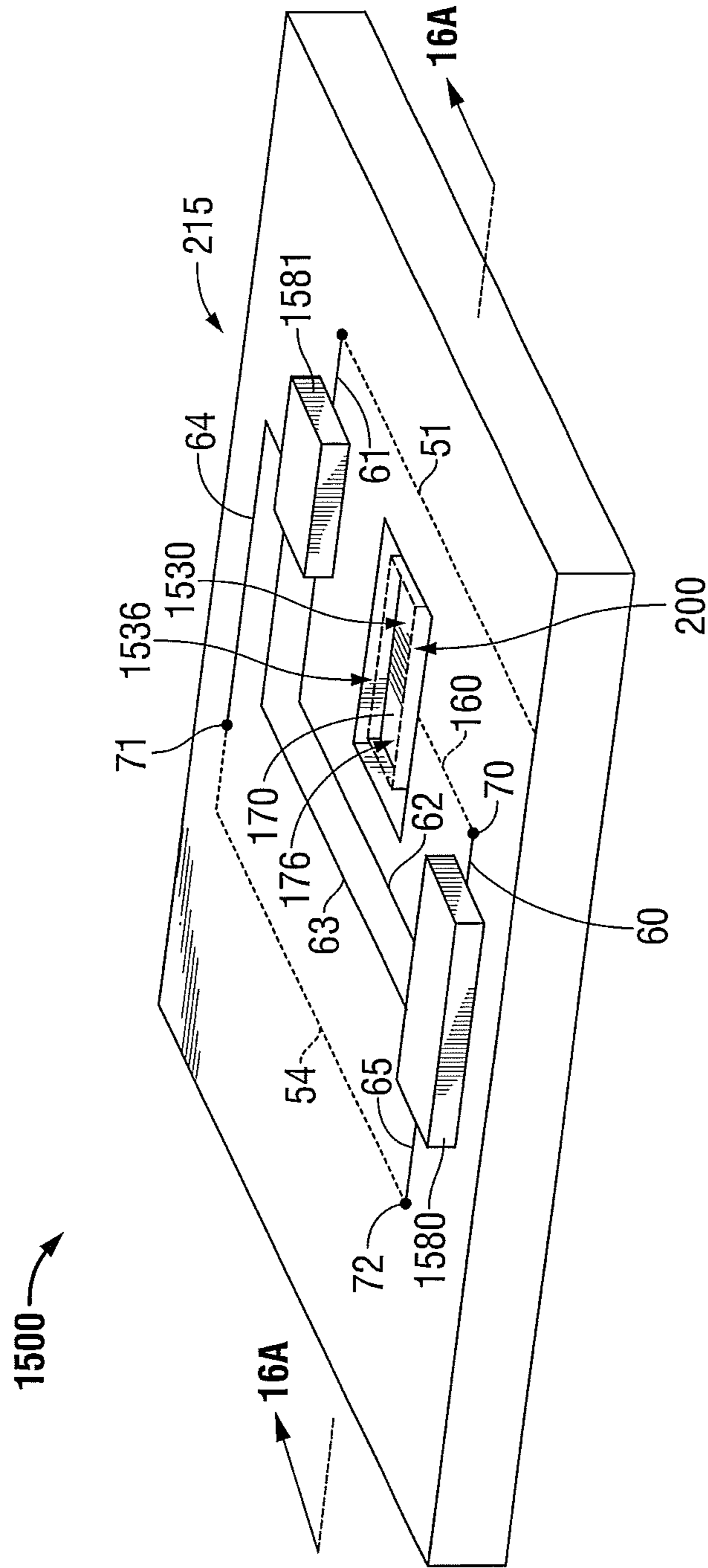

FIG. 15

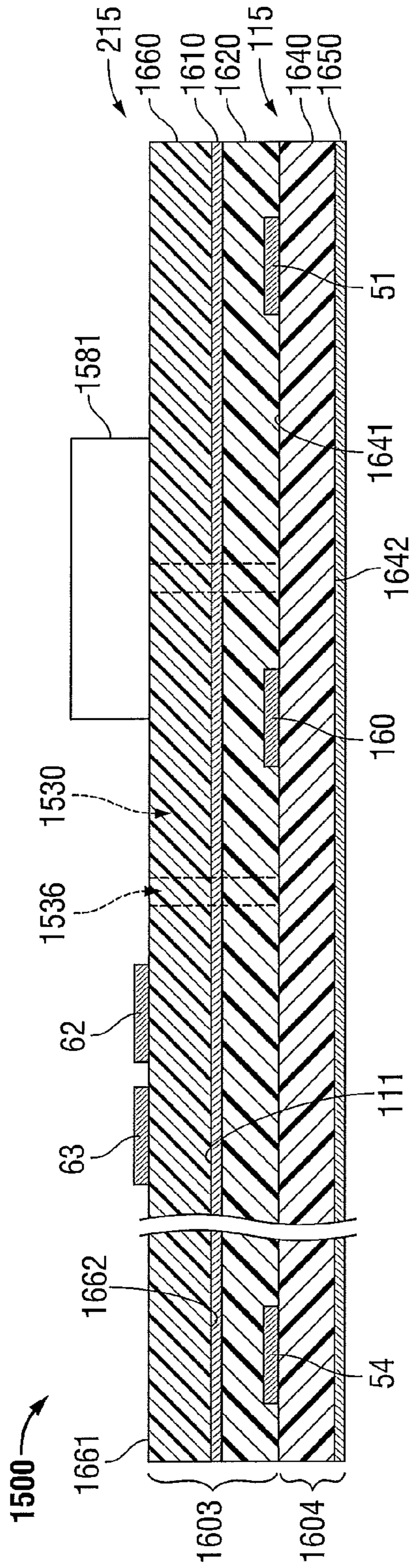

FIG. 16A

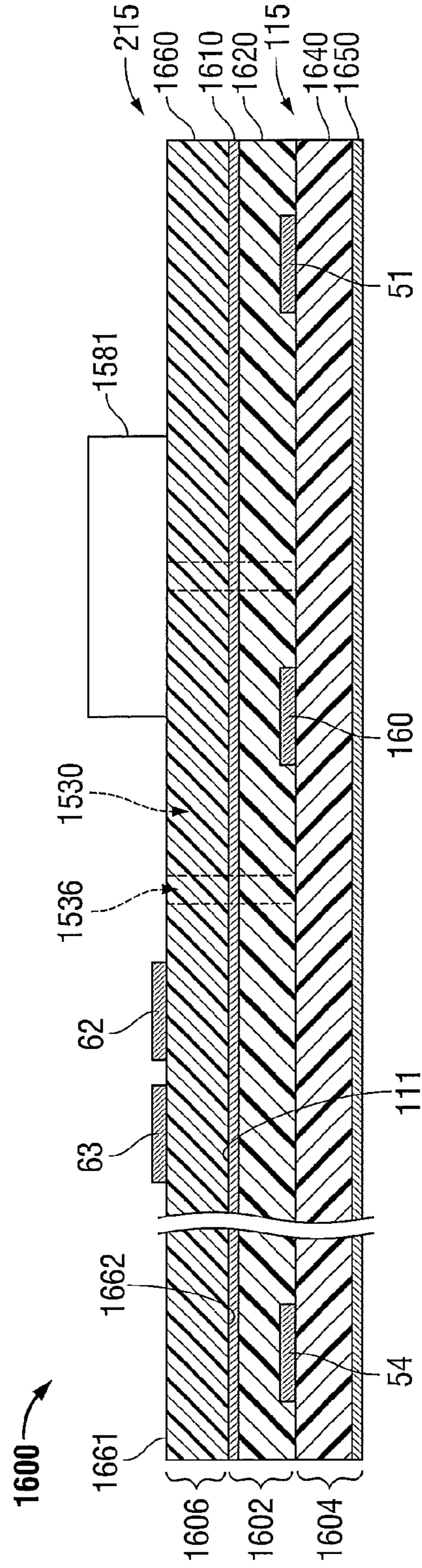

FIG. 16B

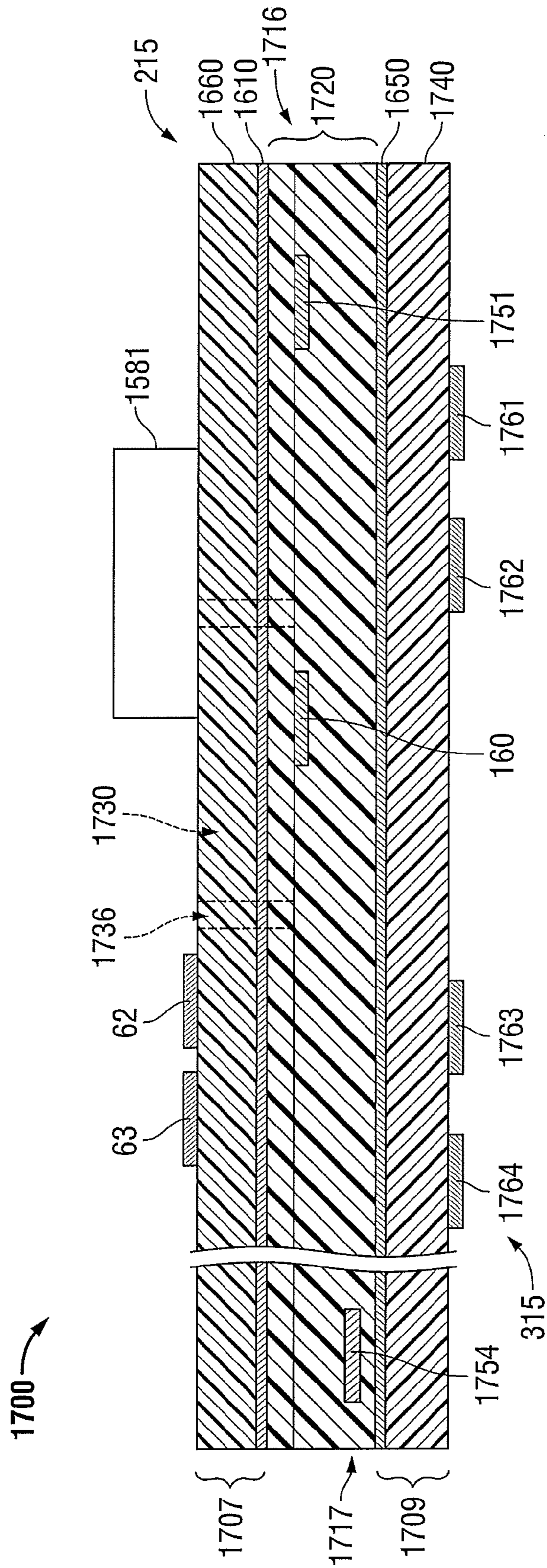

FIG. 17

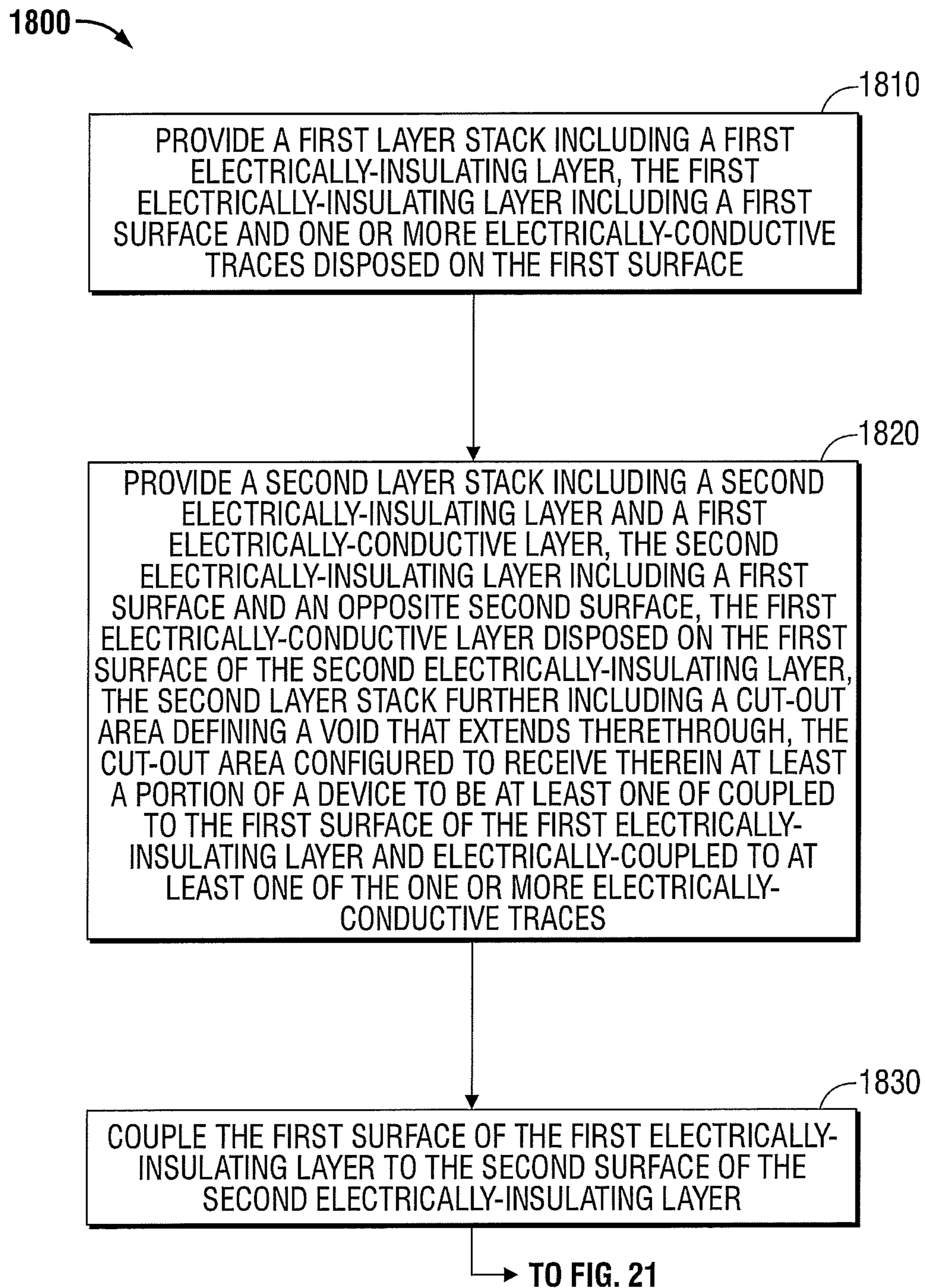

FIG. 18



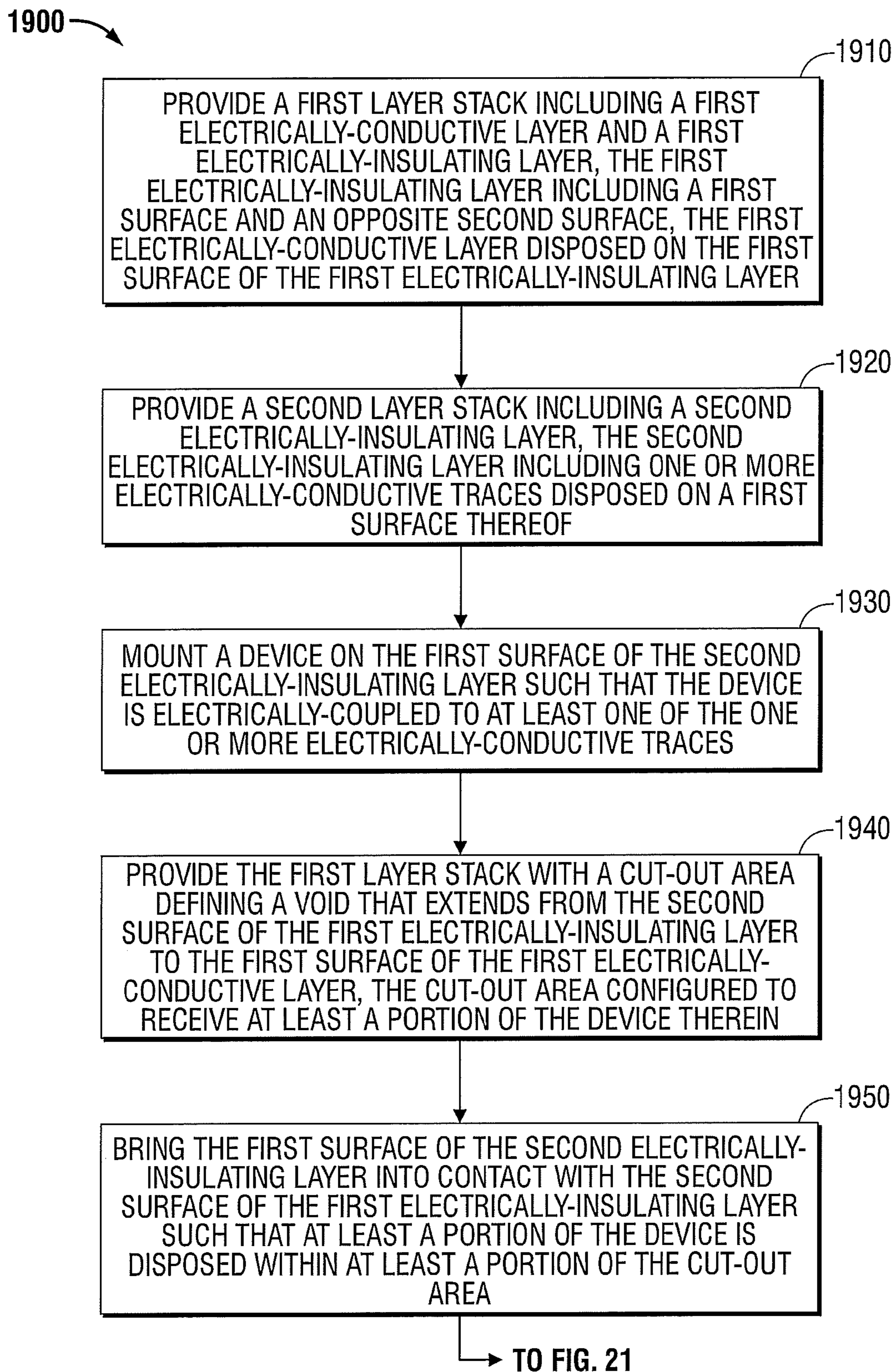

FIG. 19

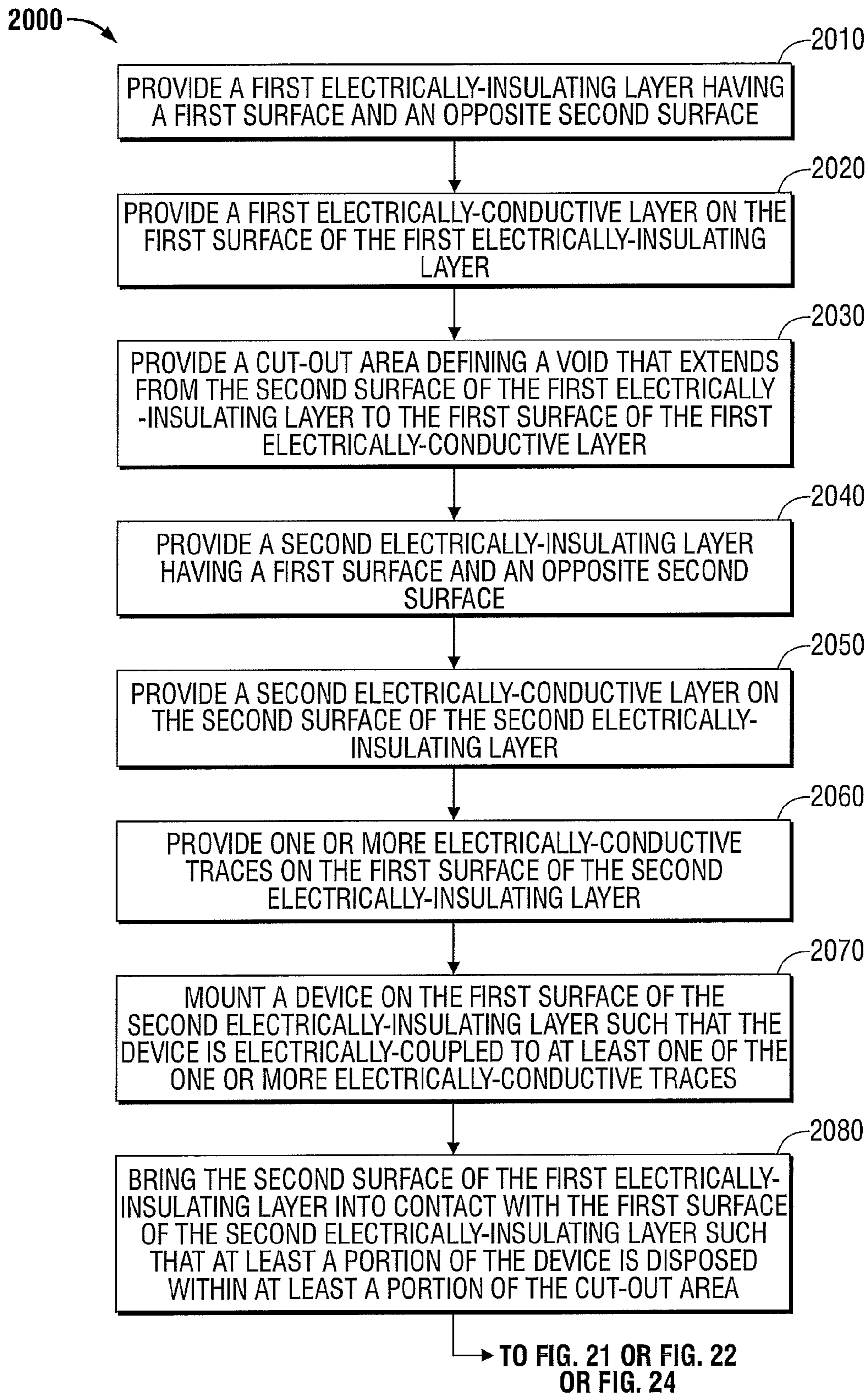

FIG. 20

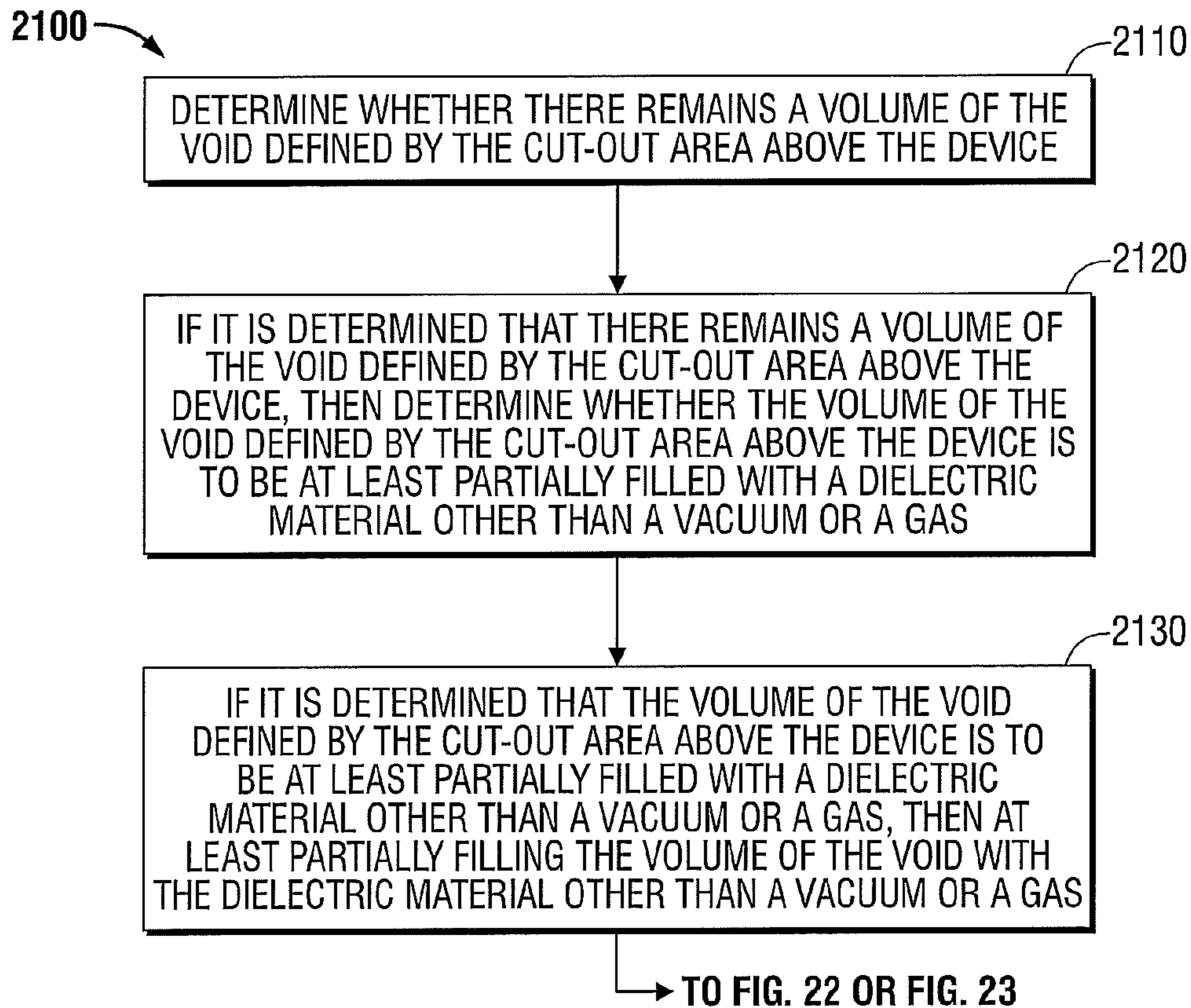

FIG. 21

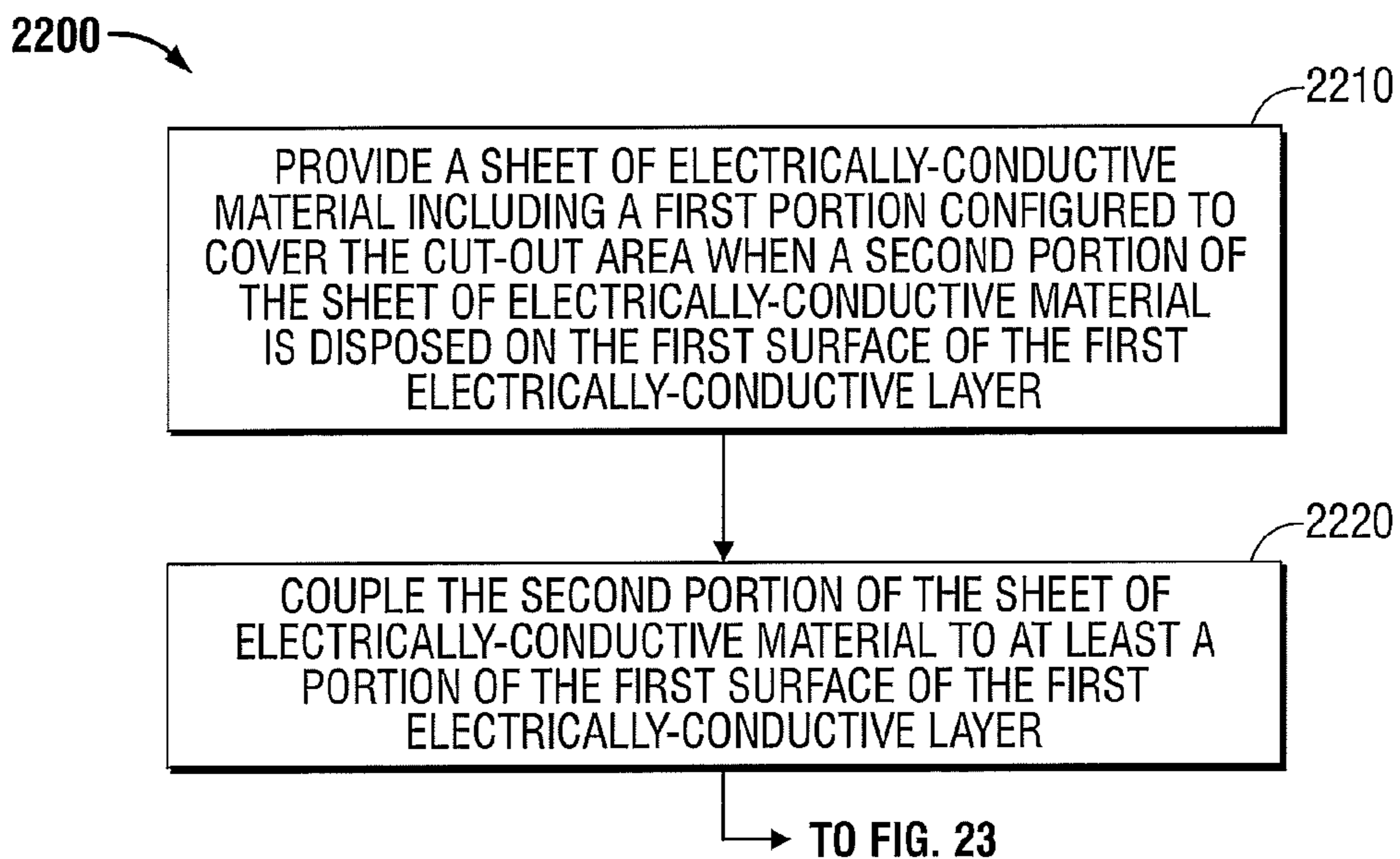
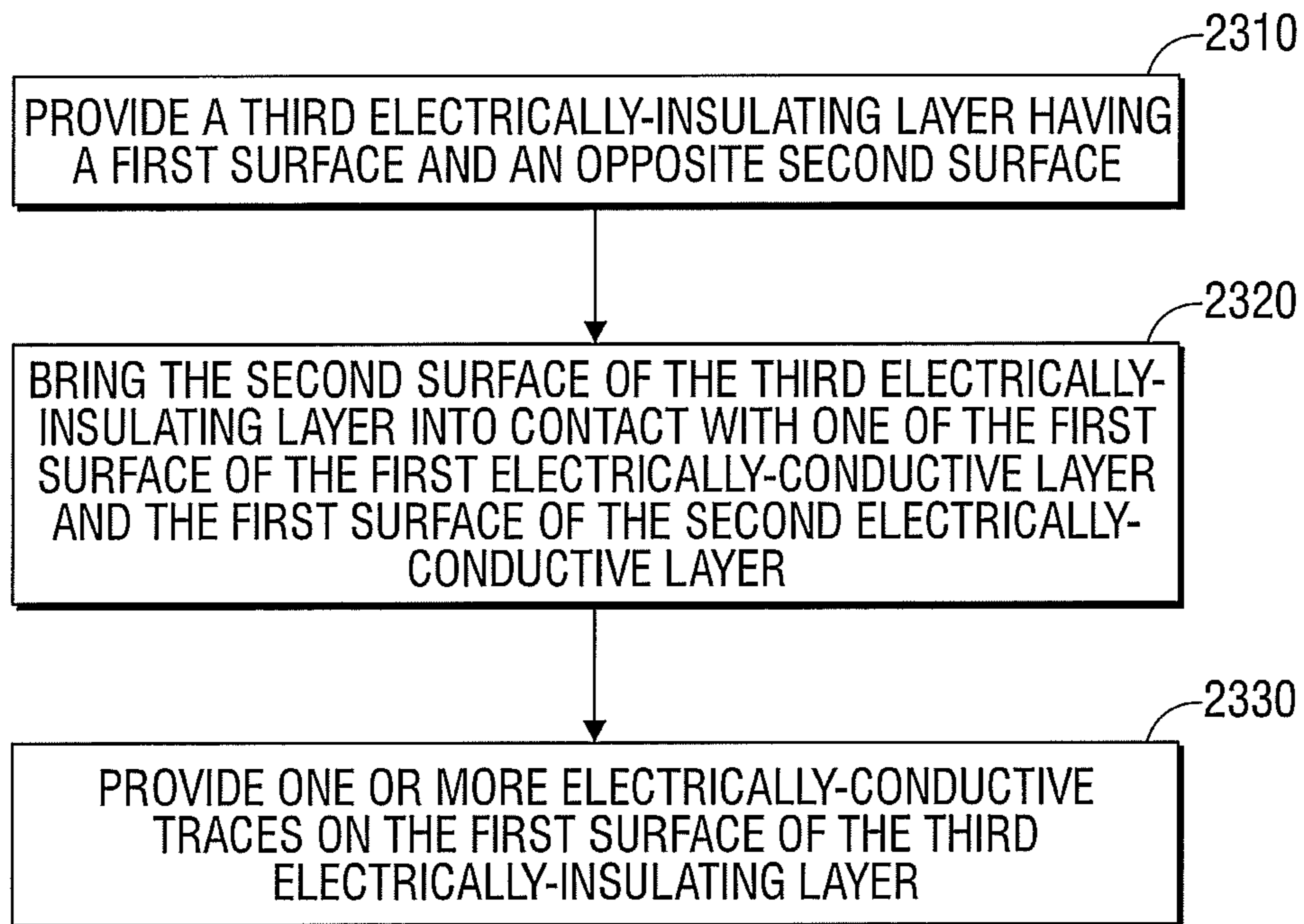
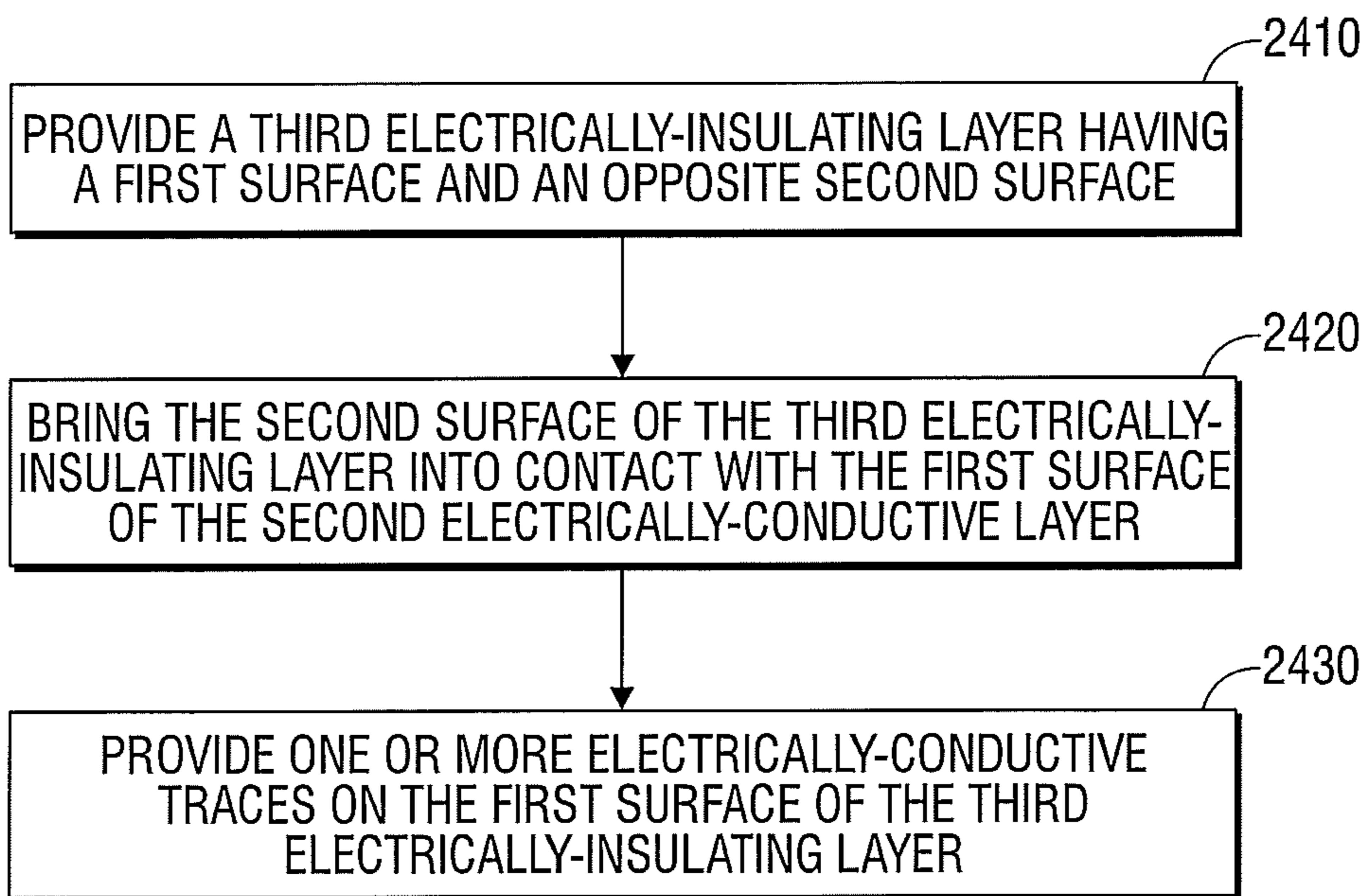

FIG. 22



**FIG. 23**



**FIG. 24**

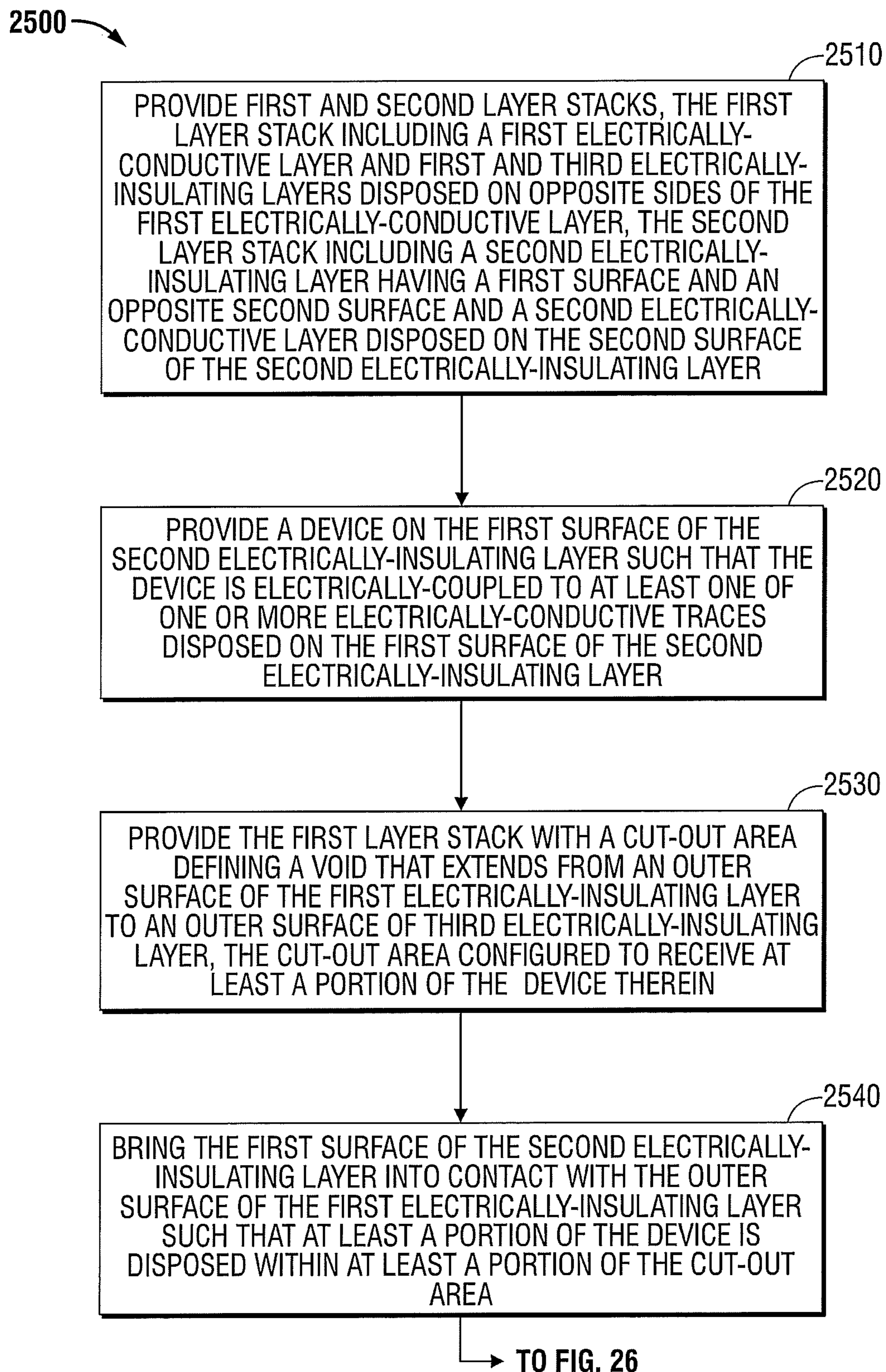
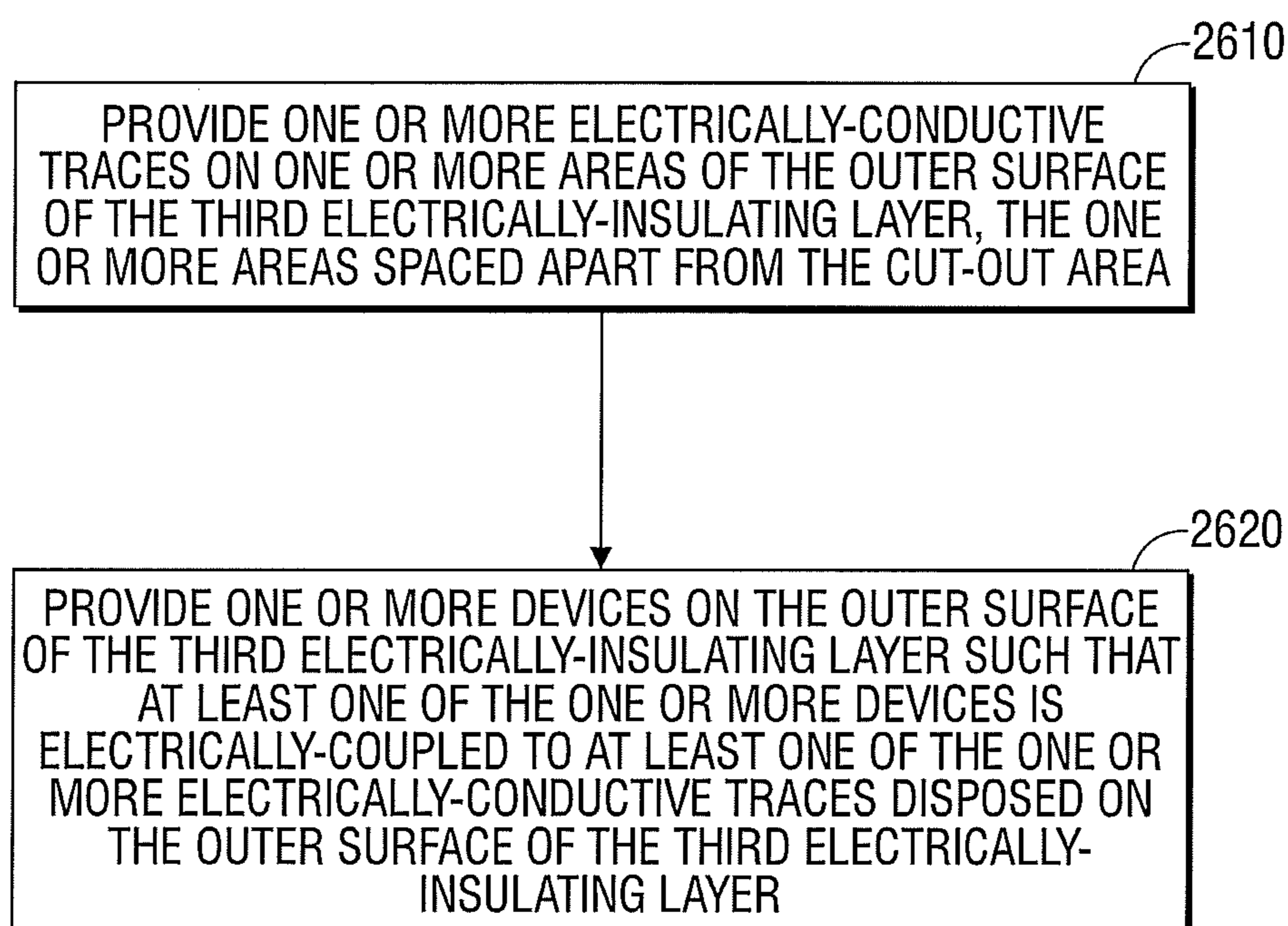

FIG. 25

**FIG. 26**

**PRINTED CIRCUIT BOARDS INCLUDING  
STRIP-LINE CIRCUITRY AND METHODS OF  
MANUFACTURING SAME**

BACKGROUND

1. Technical Field

The present disclosure relates to strip-line circuitry. More particularly, the present disclosure relates to printed circuit boards including strip-line circuitry and methods of manufacturing the same.

2. Discussion of Related Art

Commonly used techniques for circuit and/or system interconnect include microstrip and strip-line transmission lines. In a simple representation, as shown in FIG. 1, a microstrip transmission line consists of a conductive trace **13** of controlled width  $W_C$  disposed on a low-loss dielectric **11** which is, in turn, disposed on a ground-plane layer **12**. In microstrip there is one ground plane, while in strip-line, there are two.

Microstrip and strip-line transmission lines can be fabricated using printed circuit board technology. Printed circuit boards (PCBs), sometimes referred to as printed wiring boards (PWBs) or etched wiring boards, are widely used in the assembly of discrete electrical components into operating circuits. PCBs generally provide a reliable and economical means of interconnecting electrical signals between system components. PCBs are available in a variety of different types and may be classified in a variety of ways.

PCBs are generally used to mechanically support and electrically connect electronic components using electrically-conductive pathways or signal traces that conduct signals on the PCB. A typical PCB includes one or more layers of insulating material upon which patterns of electrical conductors are formed. In addition to a pattern of conductive traces on the PCB, a patterned array of metal-filled through-holes, or vias, may be formed to allow for layer-to-layer interconnections between various conductive features.

PCBs may be classified as single-sided PCBs, double-sided PCBs, and multi-layer PCBs, according to the number of circuit pattern surfaces. Microstrip transmission lines, for example, are commonly fabricated on double-sided PCBs. PCBs may include circuits that perform a single function or multiple functions.

A typical PCB may include a variety of electronic components. Electronic components form parts of electronic circuitry and may be classified in a variety of ways. An electronic component may be classified as active or passive. In general, an active component is any type of circuit component with the ability to electrically control the flow of electrons or other electrically-charged particles. Some examples of active components are transistors, integrated circuits (ICs), silicon-controlled rectifiers (SCRs), and triodes for alternating current (TRIACs). Components incapable of controlling current by means of another electrical signal are generally classified as passive components. Examples of passive components include capacitors, resistors, inductors, transformers, and diodes. A PCB on which electronic components are mounted is sometimes referred to as a printed circuit assembly (PCA) or a printed circuit board assembly (PCBA).

In some circuits, such as high-frequency circuits, e.g., microwave circuits, maintaining controlled impedance across the PCB may be required in order to achieve consistent electrical performance, e.g., in terms of amplitude and phase response. A variety of PCB trace geometries are possible with controlled impedance designs. A two-sided PCB design wherein a planar conductor line is spaced above a ground plane, as shown in the cross-sectional view of FIG. 1, can be

designed for controlled characteristic impedance. This geometry is known as a surface microstrip, or simply microstrip. In microstrip the planar conductor lines are usually formed by chemically etching away unwanted areas of material, e.g., metal, from a conductor layer, such as copper.

The impedance of a planar conductor in a microstrip transmission line format is determined by factors such as the dielectric characteristics of the surrounding materials, the width of the conductor line and its spacing from the ground-plane layer, among other things. In the surface microstrip configuration the signal conductor is exposed to air, so the effective dielectric constant impacting the impedance of the conductor is a combination of the relative dielectric constant,  $\epsilon_r$ , of the PCB dielectric substrate as well as that of the air above the circuit. Typically, the effective dielectric constant will be somewhere between 1 ( $\epsilon_r$  of air) and about 4 ( $\epsilon_r$  of FR-4 substrate).

An approximate expression of the characteristic impedance  $Z_0$  of a microstrip transmission line, as shown in FIG. 1, is given by Equation 1 (below) and is expressed in Ohms ( $\Omega$ ). In Equation 1, the measurement unit is mils, i.e., 1 mil=0.001 inches.

FIG. 1 shows a microstrip transmission line **10** that includes a signal trace **13** on the top side of a PCB dielectric substrate **11** and a ground (or power) plane **12** on the bottom side of the substrate **11**. Using Equation 1, for the signal trace **13** of width  $W_C$  and thickness  $T_C$ , separated by distance  $T_D$  from the ground plane **12** by the PCB dielectric substrate **11**, the characteristic impedance  $Z_0$  of the microstrip line **10** may be expressed as

$$Z_0(\Omega) \approx \frac{87}{\sqrt{\epsilon_r + 1.41}} \ln \left[ \frac{5.98T_D}{(0.8W_C + T_C)} \right], \quad (\text{Equation 1})$$

where  $\epsilon_r$  is the dielectric constant of the PCB substrate **11**. Equation 1 is generally valid when  $0.1 < W_C/T_D < 2.0$  and  $1 < \epsilon_r < 15$ .

Microstrip transmission line operation may be impaired by stray electromagnetic coupling between the line conductor and nearby objects. In microstrip, the line conductor is coupled to the ground plane below, which reduces EMI (electromagnetic interference) by absorbing some of the electromagnetic field lines. Fringing of the electromagnetic fields that extend above the line conductor to foreign objects may introduce irregularities into the impedance and velocity factor of the line, with a resultant negative effect on circuit performance. To mitigate the effects of electrical field fringing, additional constraints may be imposed, e.g., requiring the width of the ground plane be such that it extends past each edge of the signal trace by at least the width of the signal trace.

Strip-line transmission line construction, as shown in the cross-sectional view of FIG. 2, is generally characterized by a planar conductive trace **23** sandwiched by dielectric material **21** and disposed between two ground or power planes (commonly referred to as reference planes). An electric field **46** is generated between the conductor line **23** and the upper and lower ground layers **24** and **22**, and a magnetic field **58** is generated around the conductor line **23**. In strip-line routing, the second ground (or power) plane, which is omitted in microstrip construction, shields the conductor from the effects of nearby objects and serves to confine the electromagnetic fields to the region between the two reference planes.

In strip-line routing, all of the electromagnetic field lines are coupled to the upper and lower reference planes, and the

chance of stray coupling between the line conductor and nearby objects is avoided. In addition to minimal radiation losses, a strip-line circuit's upper and lower ground planes may form a more efficient ground return path with less surface resistance than in the microstrip configuration.

An expression of the characteristic impedance,  $Z_{0sym}$ , of a symmetric (balanced) strip-line, as shown in FIG. 1, is given by Equation 2. Using Equation 2, for the signal trace **23** of width  $W_C$  and thickness  $T_C$ , sandwiched by the PCB dielectric **21** of thickness  $T_D$  disposed between the reference planes **22** and **24**, the characteristic impedance  $Z_{0sym}$  of the symmetric strip-line **20** can be expressed as

$$Z_{0sym}(\Omega) \approx \frac{60}{\sqrt{\epsilon_r}} \ln \left[ \frac{4T_D}{0.67\pi(0.8W_C + T_C)} \right], \quad (\text{Equation 2})$$

where  $\epsilon_r$  is the dielectric constant of the PCB dielectric **21**. Equation 2 is generally valid for the following dimension ratios:  $W_C/(T_D - T_C) < 0.35$  and  $T_C/B < 0.25$ .

Microstrip and strip-line technologies are most commonly used routing configurations in circuits and can be used to provide well-characterized transmission line conductors that can be used to interconnect discrete circuit elements and to perform various impedance transformation functions. Strip-line transmission lines offer some electrical performance advantages compared to microstrip, but strip-line is more complex to fabricate than microstrip. In high-frequency circuits, e.g., microwave circuits, cost and/or space savings may be attained by using strip-line technology.

#### SUMMARY

A continuing need exists for methods of manufacturing strip-line circuits with improved fabrication and assembly techniques. A continuing need exists for strip-line configurations on printed circuit boards at lower costs. There is a need for methods of reducing the time, complexity and/or cost of strip-line fabrication operations and/or printed circuit board inspection, test, and/or rework. There is a need for methods of manufacturing printed circuit boards that allow access to components assembled into strip-line configurations.

According to one aspect, a printed circuit board is provided. The printed circuit board includes a first layer stack and a second layer stack coupled to the first layer stack. The first layer stack includes a first electrically-insulating layer, a first electrically-conductive layer, and a cut-out area defining a void that extends therethrough. The first electrically-insulating layer includes a first surface and an opposite second surface. The first electrically-conductive layer is disposed on the first surface of the first electrically-insulating layer. The second layer stack includes a second electrically-insulating layer. The second electrically-insulating layer includes a first surface and an opposite second surface. The second layer stack may further include a second electrically-conductive layer disposed on the second surface of the second electrically-insulating layer. One or more electrically-conductive traces are disposed on the first surface of the second electrically-insulating layer. The printed circuit board further includes a device at least partially disposed within the cut-out area. The device is electrically-coupled to at least one of the one or more electrically-conductive traces disposed on the first surface of the second electrically-insulating layer. The second layer stack may further include a second electrically-conductive layer disposed on the second surface of the second electrically-insulating layer.

According to one aspect, a multi-layer printed circuit board is provided. The multi-layer printed circuit board includes a first layer stack and a second layer stack coupled to the first layer stack. The first layer stack includes a first electrically-insulating layer, a second electrically-insulating layer, and a first electrically-conductive layer disposed between the first and second electrically-insulating layers. The second layer stack includes a third electrically-insulating layer and a second electrically-conductive layer. The first layer stack and/or the second layer stack include a cut-out area defining a void that extends therethrough. The multi-layer printed circuit board further includes a first signal layer and a second signal layer. The first signal layer is disposed in association with the first electrically-insulating layer of the first layer stack or the third electrically-insulating layer of the second layer stack. The second signal layer is disposed in association with the second electrically-insulating layer of the first layer stack. The multi-layer printed circuit board further includes a device at least partially disposed within the cut-out area. The device is electrically-coupled to the first signal layer and/or the second signal layer.

In any one of the above aspects, the cut-out area may be configured to receive therein at least a portion of the device. In any one of the above aspects, the device includes a top surface of the device is disposed below the second surface of the first electrically-conductive layer. In any one of the above aspects, the printed circuit board or multi-layer printed circuit board may further include a sheet of electrically-conductive material including a first portion configured to cover the cut-out area. The sheet of electrically-conductive material may further include a second portion disposed on at least a portion of the first surface of the first electrically-conductive layer.

In any one of the above aspects, an area of the first surface of the first electrically-insulating layer disposed adjacent to the cut-out area is an exposed area. The printed circuit board or multi-layer printed circuit board may further include a sheet of electrically-conductive material including a first portion and a second portion, wherein the first portion is configured to cover the cut-out area and the second portion is disposed on the exposed area of first surface of the first electrically-insulating layer.

According to a further aspect, a method of manufacturing a printed circuit board is provided. The method includes the initial steps of providing a first layer stack and providing a second layer stack. The first layer stack includes a first electrically-insulating layer. The first electrically-insulating layer includes a first surface and one or more electrically-conductive traces disposed on the first surface. The second layer stack includes a second electrically-insulating layer and a first electrically-conductive layer. The second electrically-insulating layer includes a first surface and an opposite second surface. The first electrically-conductive layer is disposed on the first surface of the second electrically-insulating layer. The second layer stack further includes a cut-out area defining a void that extends therethrough. The cut-out area is configured to receive therein at least a portion of a device to be coupled to the first surface of the first electrically-insulating layer and/or electrically-coupled to one or more of the one or more electrically-conductive traces. The first layer stack may further include a second electrically-conductive layer disposed on the second surface of the first electrically-insulating layer. The method may further include the step of coupling the first surface of the first electrically-insulating layer to the second surface of the second electrically-insulating layer. The coupling step may include the step of orienting the first layer stack and the second layer stack in relation to one another such that the first surface of the first electrically-insulating



5

layer opposes the second surface of the second electrically-insulating layer. The coupling step may further include the step of positioning the first layer stack and the second layer stack in relation to one another such that the cut-out area is positioned to receive the at least a portion of the device therein when the first surface of the first electrically-insulating layer is placed in contact with the second surface of the second electrically-insulating layer. The coupling step may further include the step of bonding the second electrically-conductive layer of the third layer stack to the first electrically-insulating layer of the first layer stack.

The method may further include the step of mounting the device on the first layer stack. The mounting step may include the step of placing at least a portion of the device within the cut-out area. The mounting step may further include the step of electrically-coupling the device to one or more of the one or more electrically-conductive traces. The method may further include the step of coupling a third layer stack to the first layer stack. The third layer stack may include a signal layer and a third electrically-insulating layer including a first surface and an opposite second surface. The signal layer may be disposed in association with the first surface of the third electrically-insulating layer. The third layer stack may further include a second electrically-conductive layer including a first surface and an opposite second surface, the first surface of the second electrically-conductive layer disposed on the second surface of the third electrically-insulating layer.

According to a further aspect, a method of manufacturing a printed circuit board is provided. The method includes the initial steps of providing a first layer stack including a first electrically-conductive layer and a first electrically-insulating layer and providing a second layer stack including a second electrically-insulating layer. The first electrically-insulating layer includes a first electrically-insulating layer including a first surface and an opposite second surface. The first electrically-conductive layer is disposed on the first surface of the first electrically-insulating layer. The second electrically-insulating layer includes one or more electrically-conductive traces disposed on a first surface thereof. The method also includes the steps of mounting a device on the first surface of the second electrically-insulating layer such that the device is electrically-coupled to at least one of the one or more electrically-conductive traces, and providing the first layer stack with a cut-out area defining a void that extends from the second surface of the first electrically-insulating layer to the first surface of the first electrically-conductive layer. The cut-out area is configured to receive at least a portion of the device therein. The method also includes the step of placing the first surface of the second electrically-insulating layer in contact with the second surface of the first electrically-insulating layer such that at least a portion of the device is disposed within at least a portion of the cut-out area.

According to a further aspect, a method of manufacturing a printed circuit board is provided. The method includes the initial steps of providing a first electrically-insulating layer having a first surface and an opposite second surface, providing a first electrically-conductive layer on the first surface of the first electrically-insulating layer, and providing a cut-out area defining a void that extends from the second surface of the first electrically-insulating layer to the first surface of the first electrically-conductive layer. The step of providing a first electrically-conductive layer on the first surface of the first electrically-insulating layer may include patterning, e.g., photo-etching, the first electrically-conductive layer to provide an exposed area on the first surface of the first electrically-insulating layer disposed adjacent to the cut-out area.

6

The method also includes the steps of providing a second electrically-insulating layer having a first surface and an opposite second surface, providing a second electrically-conductive layer on the second surface of the second electrically-insulating layer, providing one or more electrically-conductive traces on the first surface of the second electrically-insulating layer, mounting a device on the first surface of the second electrically-insulating layer such that the device is electrically-coupled to at least one of the one or more electrically-conductive traces, and placing the second surface of the first electrically-insulating layer in contact with the first surface of the second electrically-insulating layer such that at least a portion of the device is disposed within at least a portion of the cut-out area.

In any one of the above aspects, the method of manufacturing a printed circuit board may further include the steps of: determining whether there remains a volume of the void defined by the cut-out area above the device; if it is determined that there remains a volume of the void defined by the cut-out area above the device, then determining whether the volume of the void defined by the cut-out area above the device is to be at least partially filled with a dielectric material other than a vacuum or a gas (or mixture of gases, such as air); and if it is determined that the volume of the void defined by the cut-out area above the device is to be at least partially filled with a dielectric material other than a vacuum or a gas or a mixture of gases, then at least partially filling the volume of the void with the dielectric material other than a vacuum or a gas or a mixture of gases.

In any one of the above aspects, the method of manufacturing a printed circuit board may further include the steps of providing a sheet of electrically-conductive material including a first portion configured to cover the cut-out area when a second portion of the sheet of electrically-conductive material is disposed on the first surface of the first electrically-conductive layer, and coupling the second portion of the sheet of the electrically-conductive material to at least a portion of the first surface of the first electrically-conductive layer.

In any one of the above aspects, the method of manufacturing a printed circuit board may further include the steps of providing a third electrically-insulating layer having a first surface and an opposite second surface, placing the second surface of the third electrically-insulating layer in contact with one of the first surface of the first electrically-conductive layer and the first surface of the second electrically-conductive layer, and providing one or more electrically-conductive traces on the first surface of the third electrically-insulating layer.

In any one of the above aspects, the method of manufacturing a printed circuit board may further include the steps of providing a third electrically-insulating layer having a first surface and an opposite second surface, placing the second surface of the third electrically-insulating layer in contact with the first surface of the second electrically-conductive layer, and providing one or more electrically-conductive traces on the first surface of the third electrically-insulating layer.

According to a further aspect, a method of manufacturing a printed circuit board is provided. The method includes the initial step of providing first and second layer stacks. The first layer stack includes a first electrically-conductive layer. The first layer stack further includes first and third electrically-insulating layers disposed on opposite sides of the first electrically-conductive layer. The second layer stack includes a second electrically-insulating layer having a first surface and an opposite second surface. The second layer stack further includes a second electrically-conductive layer disposed on the second surface of the second electrically-insulating layer.

The method further includes the steps of providing a device on the first surface of the second electrically-insulating layer such that the device is electrically-coupled to at least one of one or more electrically-conductive traces disposed on the first surface of the second electrically-insulating layer, and providing the first layer stack with a cut-out area defining a void that extends from an outer surface of the first electrically-insulating layer to an outer surface of third electrically-insulating layer. The cut-out area is configured to receive at least a portion of the device therein. The method may further include the step of placing the first surface of the second electrically-insulating layer in contact with the outer surface of the first electrically-insulating layer such that at least a portion of the device is disposed within at least a portion of the cut-out area.

The method may further include the step of providing a pattern of one or more electrically-conductive traces on one or more areas of the outer surface of the third electrically-insulating layer. The one or more areas are spaced apart from the cut-out area. The method may further include the step of providing one or more devices on the outer surface of the third electrically-insulating layer such that at least one of the one or more devices is electrically-coupled to at least one of the one or more electrically-conductive traces disposed on the outer surface of the third electrically-insulating layer.

In any one of the above aspects, the cut-out area may be configured to receive therein at least a portion of the device. In any one of the above aspects, the height of the device may be less than the thickness of the first electrically-insulating layer. In any one of the above aspects, the device may include a top surface and a bottom surface. In any one of the above aspects, the top surface of the device may be disposed below the second surface of the first electrically-conductive layer. In any one of the above aspects, the height of the device may be greater than the height of the first layer stack.

In any one of the above aspects, the printed circuit board may further include a sheet of electrically-conductive material configured to cover the cut-out area. The sheet of electrically-conductive material may include a first portion configured to cover the cut-out area and a second portion disposed on at least a portion of the first surface of the first electrically-conductive layer.

In any one of the above aspects, an area of the first surface of the first electrically-insulating layer disposed adjacent to the cut-out area may be an exposed area. In any one of the above aspects, the sheet of electrically-conductive material includes a first portion configured to cover the cut-out area and a second portion disposed on the exposed area of first surface of the first electrically-insulating layer.

In any one of the above aspects, the printed circuit board may further include one or more gap areas disposed in adjoining relation to the cut-out area. The one or more gap areas may be configured to physically isolate the device from the first electrically-conductive layer and/or electrically isolate the device from the first electrically-conductive layer.

In any one of the above aspects, the printed circuit board may further include a heat sink disposed in association with the top surface of the device.

In any one of the above aspects, the void defined by the cut-out area may include a first volume of void space defined between the top surface of the device and a plane containing the first surface of the first electrically-conductive layer. The printed circuit board may further include dielectric material disposed in at least a portion of the first volume of void space.

In any one of the above aspects, the printed circuit board may further include a sheet of electrically-conductive material configured to cover the cut-out area.

In any one of the above aspects, the printed circuit board may further include a third layer stack coupled to the first layer stack, the third layer stack including a third electrically-insulating layer having a first surface. The printed circuit board may further include a signal layer disposed in association with the first surface of the third electrically-insulating layer. The printed circuit board may further include a cut-out area defining a void that extends from the first surface of the third electrically-insulating layer to first surface of the second electrically-insulating layer.

#### BRIEF DESCRIPTION OF THE DRAWINGS

Objects and features of the presently-disclosed printed circuit boards including strip-line circuitry and methods of manufacturing the same will become apparent to those of ordinary skill in the art when descriptions of various embodiments thereof are read with reference to the accompanying drawings, of which:

FIG. 1 is an enlarged, cross-sectional view of a printed circuit board (PCB) having a microstrip transmission line according to a conventional technology;

FIG. 2 is an enlarged, cross-sectional view of a PCB having a symmetric strip-line transmission line according to a conventional technology;

FIG. 3 is an enlarged, perspective, cross-sectional view of a portion of a PCB with layer stacks separated including a cut-out area defined in a first layer stack according to an embodiment of the present disclosure;

FIG. 4 is an enlarged, perspective, cross-sectional view of the PCB of FIG. 3 shown assembled with a device disposed in a first-level configuration within the cut-out area according to an embodiment of the present disclosure;

FIG. 5 is an enlarged, cross-sectional view of a PCB including an asymmetric strip-line transmission line according to an embodiment of the present disclosure;

FIG. 6 is an enlarged, perspective, cross-sectional view of an embodiment of a first layer stack including the cut-out area of the PCB shown in FIG. 3 defined therethrough shown with a configuration of gap areas disposed along two opposite sides of the cut-out area according to the present disclosure;

FIG. 7 is an enlarged, perspective, cross-sectional view of an embodiment of a first layer stack including the cut-out area of the PCB shown in FIG. 3 defined therethrough shown with a configuration of gap areas disposed around the outer periphery of the cut-out area according to the present disclosure;

FIG. 8 is an enlarged, perspective, cross-sectional view of a portion of a PCB including the first layer stack of FIG. 6 and the second layer stack of FIG. 3 shown assembled with a device disposed in a first-level configuration within the cut-out area according to an embodiment of the present disclosure;

FIG. 9 is an enlarged, perspective, cross-sectional view of a portion of a PCB including the first layer stack of FIG. 7 and the second layer stack of FIG. 3 shown assembled with a device disposed in a first-level configuration within the cut-out area according to an embodiment of the present disclosure;

FIG. 10A is an enlarged, perspective, cross-sectional view of a portion of a PCB with layer stacks separated that includes the first layer stack of FIG. 7 shown with the cut-out and gap areas defined therethrough and the second layer stack of FIG. 3 shown with a portion of a conductor line disposed thereon according to an embodiment of the present disclosure;

FIG. 10B is an enlarged, perspective, cross-sectional view of the PCB of FIG. 10A shown with a device positioned for placement onto the second layer stack through the cut-out area of the first layer stack according to an embodiment of the present disclosure;

FIG. 10C is an enlarged, perspective, cross-sectional view of the PCB of FIG. 10B shown assembled with a device disposed in a second-level configuration within the cut-out area according to an embodiment of the present disclosure;

FIG. 11 is an enlarged, perspective, cross-sectional view of the PCB of FIG. 10C shown with a portion of a heat sink layer according to an embodiment of the present disclosure;

FIG. 12 is an enlarged, perspective, cross-sectional view of a portion of a PCB with layer stacks separated including another embodiment of a first layer stack including a cut-out area defined therethrough and the second layer stack of FIG. 3 according to the present disclosure;

FIG. 13 is an enlarged, perspective, cross-sectional view of a portion of a PCB with layer stacks separated including a first cut-out area defined in a first layer stack and a second cut-out area defined in a second layer stack according to an embodiment of the present disclosure;

FIG. 14 is an enlarged, perspective, cross-sectional view of a portion of a PCB with layer stacks separated including the first layer stack of FIG. 13 and another embodiment of a second layer stack including a cut-out area defined therethrough according to the present disclosure;

FIG. 15 is a schematic, enlarged, perspective view of a portion of a PCB according to another embodiment of the present disclosure;

FIG. 16A is an enlarged, cross-sectional view taken along section lines 16A-16A of FIG. 15;

FIG. 16B is an enlarged, cross-sectional view of an alternative embodiment of the PCB shown in FIGS. 15 and 16A according to the present disclosure;

FIG. 17 is an enlarged, cross-sectional view of a portion of a PCB according to yet another embodiment of the present disclosure;

FIG. 18 is a flowchart illustrating a method of manufacturing a PCB in accordance with an embodiment of the present disclosure;

FIG. 19 is a flowchart illustrating a method of manufacturing a PCB in accordance with an embodiment of the present disclosure;

FIG. 20 is a flowchart illustrating a method of manufacturing a PCB in accordance with another embodiment of the present disclosure;

FIG. 21 is a flowchart illustrating a method of manufacturing a PCB in accordance with another embodiment of the present disclosure;

FIG. 22 is a flowchart illustrating a method of manufacturing a PCB in accordance with yet another embodiment of the present disclosure;

FIG. 23 is a flowchart illustrating a method of manufacturing a PCB in accordance with yet another embodiment of the present disclosure;

FIG. 24 is a flowchart illustrating a method of manufacturing a PCB in accordance with yet another embodiment of the present disclosure;

FIG. 25 is a flowchart illustrating a method of manufacturing a PCB in accordance with still another embodiment of the present disclosure; and

FIG. 26 is a flowchart illustrating a method of manufacturing a PCB in accordance with still another embodiment of the present disclosure.

#### DETAILED DESCRIPTION

Hereinafter, embodiments of the presently-disclosed printed circuit boards including strip-line circuitry and meth-

ods of manufacturing the same are described with reference to the accompanying drawings. Like reference numerals may refer to similar or identical elements throughout the description of the figures. As shown in the drawings and as used in this description, and as is traditional when referring to relative positioning on an object, the term “proximal” refers to that portion of the device, or component thereof, closer to the user and the term “distal” refers to that portion of the device, or component thereof, farther from the user.

This description may use the phrases “in an embodiment,” “in embodiments,” “in some embodiments,” or “in other embodiments,” which may each refer to one or more of the same or different embodiments in accordance with the present disclosure. For the purposes of this description, a phrase in the form “A/B” means A or B. For the purposes of the description, a phrase in the form “A and/or B” means “(A), (B), or (A and B)”.

As it is used in this description, “printed circuit board” (or “PCB”) or “circuit boards” generally refers to systems that provide, among other things, mechanical support to electrical devices and/or components, electrical connection to and between these electrical devices and/or components, combinations thereof, and the like. For the purposes herein, the term “printed circuit board” is interchangeable with the term “printed wiring board” and either is represented herein by the acronym PCB. The PCBs described herein may include electrical components. In general, the term “printed circuit board” is interchangeable, in this disclosure, with the terms “printed circuit assembly” and “printed circuit board assembly”. The PCBs and circuit boards described herein are not limited to electrical component-populated boards, but also include non-populated circuit-traced substrates of all types.

PCB embodiments described herein include one or more layer stacks formed of a plurality of layers of suitable electrically-conductive and/or non-conductive materials. Examples of suitable materials may include, without limitation, dielectrics, e.g., polytetrafluoroethylene (Teflon®), FR-4 (flame retardant 4), CEM-1 or CEM-3, low-loss dielectric PCB material, e.g., Rogers 4350, GETEK® or ARLON, electrically-conductive materials such as without limitation metal, e.g., copper foil, fibrous materials, e.g., carbon, graphite, graphene, glass, quartz, polyethylene or liquid crystal polymer fibers, prepreg materials, e.g., FR-2 (phenolic cotton paper), FR-3 (cotton paper and epoxy), FR-4 (woven glass and epoxy), FR-5 (woven glass and epoxy), FR-6 (matte glass and polyester), G-10 (woven glass and epoxy), CEM-1 (cotton paper and epoxy), CEM-2 (cotton paper and epoxy), CEM-3 (woven glass and epoxy), CEM-4 (woven glass and epoxy) or CEM-5 (woven glass and polyester), or other suitable electrically-conductive or non-conductive materials, e.g., fibrous materials with low coefficients of thermal expansion that are metalized to provide a resultant electrically-conductive material with a low coefficient of thermal expansion.

As it is used in this description, “electrically conductive”, or simply “conductive”, generally refers to materials that are capable of electrical conductivity, including, without limitation, materials that are highly conductive, e.g., metals, or semi-conductive, e.g., semi-conducting materials and composites. As it is used in this description, “ground plane” refers to not only conductive planes which in operation are coupled to ground potential, but also conductive planes that may be coupled to other circuit potentials. Generally speaking, a ground plane is a relatively large plane of material having low electrical impedance. In implementations, it may actually be either a ground plane or a power plane (commonly referred to as reference planes).

## 11

Various embodiments of the presently-disclosed PCBs include at least one layer stack that includes an electrically-conductive layer (e.g., a ground plane or a power plane), an electrically-insulating layer (also referred to herein as an “insulative layer”) and one or more cut-out areas defining a void that extends therethrough. In embodiments of the presently-disclosed PCBs, a variety of electrically-conductive traces (e.g., strip-line traces, microstrip traces, embedded microstrip traces, and/or combinations thereof) may be used in conjunction with one or more power planes to form transmission lines.

The presently-disclosed PCBs according to embodiments may be multi-layer PCBs that employ a variety of transmission lines, including, without limitation, strip-line configurations on internal layers of the PCB, e.g., providing power distribution, digital signal processing, and other functions, and/or microstrip configurations on external layers of the PCB.

Various embodiments of the presently-disclosed PCBs include one or more cut-out areas defined in at least one layer stack, and may provide strip-line shielding capability along with microstrip-like accessibility to add components on and off the circuit board and/or to perform other operations, e.g., testing. The presently-disclosed PCBs including one or more cut-out areas defined in one or more layer stacks may provide the capability to add or remove component capacitance to equalize the line.

Although the following description describes the use of symmetric (balanced) strip-line construction in PCB embodiments including one or more cut-out areas defined in one or more layer stacks, the teachings of the present disclosure may also apply to asymmetric or offset (unbalanced) strip-line routing. A PCB embodiment that includes an asymmetric strip-line transmission line is shown in the cross-sectional view of FIG. 5. A multi-layer PCB embodiment including an asymmetric strip-line configuration is shown in FIG. 17.

FIG. 3 shows a portion of a PCB 100 with first and second layer stacks separated according to an embodiment of the present disclosure. PCB 100 includes a first layer stack 102 and a second layer stack 104. First layer stack 102 includes a cut-out area 130 defined therethrough. Although only one cut-out area 130 is shown in FIG. 3 for ease of illustration, it is to be understood that PCB 100 may include any number of cut-out areas defined in the first layer stack 102 and/or the second layer stack 104. As shown in FIG. 3, the first layer stack 102 has a height “ $H_1$ ”. Height “ $H_1$ ” may be any suitable height. First layer stack 102 generally includes a first conductive layer 110 and a first insulative layer 120 upon which the first conductive layer 110 is supported. In some embodiments, the first conductive layer 110 may be either a power plane or a ground plane.

Second layer stack 104 includes a second insulative layer 140. First insulative layer 120 and the second insulative layer 140 may include any suitable material configured to resist, or substantially resist, the flow of electricity and to provide physical support for, among other things, one or more conductive layers, electrical and/or electronic components, devices, connectors, etc. In some embodiments, the first insulative layer 120 and/or the second insulative layer 140 may include one or more layers of dielectric laminate.

As shown in FIG. 3, the first conductive layer 110 generally includes a first surface 111 and an opposite second surface 112. First conductive layer 110 may include a single layer or multiple layers disposed between the first and second surfaces 111 and 112, respectively. Second conductive layer 150 generally includes a first surface 151 and an opposite second surface 152. Second conductive layer 150 may include a

## 12

single layer, or a plurality of layers, disposed between the first and second surfaces 151 and 152, respectively.

First insulative layer 120 generally includes a first surface 121 and an opposite second surface 122. First insulative layer 120 may include a single layer, or a plurality of layers, disposed between the first and second surfaces 121 and 122, respectively. First insulative layer 120 may have any suitable thickness “ $T_{D1}$ ”. Height “ $H_2$ ” of the device 170 may be less than the thickness “ $T_{D1}$ ” of the first insulative layer 120.

In some embodiments, the first conductive layer 110 may be deposited directly on, or coupled to, the first surface 121 of the first insulative layer 120. Alternatively, one or more layers (not shown) may be disposed between the second surface 112 of the first conductive layer 110 and the first surface 121 of the first insulative layer 120. In an alternative embodiment not shown, a sheet of thermally-responsive material may be disposed between the first surface 121 of the first insulative layer 120 and the second surface 112 of the first conductive layer 110, e.g., to form a laminated bond therebetween. In some embodiments, the first conductive layer 110 and the first insulative layer 120 are arranged in substantially parallel planes.

In some embodiments, as shown in FIG. 3, a second conductive layer 150 and a circuit 176 are disposed on opposite sides of the second insulative layer 140. In some embodiments, the second conductive layer 150 may be either a power plane or a ground plane. Circuit 176 generally includes a device 170 and one or more electrically-conductive traces 160 disposed on the second insulative layer 140. Circuit 176 may include a collection of circuit elements, e.g., transistors, diodes, capacitors, and resistors, as well as signal lines and other conductors that interconnect these various circuit elements. Conductive traces 160 have a controlled width “ $W_C$ ” and a thickness “ $T_C$ ”, and may be formed of any suitable electrically-conductive material, e.g., copper, gold, silver or other conductive metals having suitable conductivity values. Conductive traces of the circuit 176 may be characterized by a first width “ $W_{C1}$ ” of an upper surface thereof and a second width “ $W_{C2}$ ” of a lower surface, as shown in FIG. 5.

Device 170 may be electrically-coupled to one or more conductive traces 160. Device 170 may include any electrical device, electrical component, electronic device, electronic component, semiconductor component, etc. Device 170 may include any electrical connector, such as without limitation surface mount connectors in SMA, SMB, SMC, SSMB, and SSMC. In some embodiments, multiple electrical components may be assembled into the device 170, which itself may be used as a component. Device 170 may include active devices and/or passive devices. In some embodiments, the device 170 may be a capacitor.

Device 170 generally includes a top surface 171 and a bottom surface 173. Device 170 includes a height “ $H_2$ ” defined between the top and bottom surfaces 171 and 173, respectively. Height “ $H_2$ ” may be any suitable height. In some embodiments, the height “ $H_2$ ” of the device 170 is less than the height “ $H_1$ ” of the first layer stack 102. Device 170 may take a variety of shapes and sizes. For ease of explanation and understanding, the device 170 is shown as a single element having a rectangular shape.

First conductive layer 110 and the second conductive layer 150 may be formed of any suitable electrically-conductive material, e.g., copper, gold, silver or other conductive metals having suitable conductivity values. In some embodiments, the first conductive layer 110 and/or the second conductive layer 150 may be a conductive foil. Conductive materials that may be used to form the first conductive layer 110 and/or the second conductive layer 150 may be plated with other mate-

rials, e.g., other conductive materials such as gold or silver, to improve their properties, e.g., to improve electrical conductivity.

Second insulative layer **140** generally includes a first surface **141** and an opposite second surface **142**. Second insulative layer **140** may include a single layer or multiple layers disposed between the first and second surfaces **141** and **142**, respectively. Second insulative layer **140** may have any suitable thickness " $T_{D2}$ ". In some embodiments, the first insulative layer **120** is formed from a material with a dielectric constant different than the dielectric constant of the second insulative layer **140**.

In some embodiments, the thickness " $T_{D1}$ " of the first insulative layer **120** of the first layer stack **102** may be substantially equal to the thickness " $T_{D2}$ " of the second insulative layer **140** of the second layer stack **104**. Alternatively, the thickness " $T_{D1}$ " of the first insulative layer **120** may be less than, or greater than, the thickness " $T_{D2}$ " of the second insulative layer **140**.

As best shown in FIG. 3, the first layer stack **102** includes a cut-out area **130** defining a void that extends from the second surface **122** of the first insulative layer **120** to the first surface **111** of the first conductive layer **110**. The height of the cut-out area **130** is generally equal to the height " $H_1$ " of the first layer stack **102**. Cut-out area **130** according to embodiments is configured to receive at least a portion of the device **170** therein. Cut-out area **130** may take a variety of shapes and sizes.

In some embodiments, the void defined by the cut-out area **130** may include a first volume " $V_1$ " of void space and a second volume " $V_2$ " of void space. The first volume " $V_1$ " of void space is defined between the top surface **171** of the device **130** and a plane (depicted by arrow-headed dotted lines in FIG. 4) containing the first surface **111** of the first electrically-conductive layer **110**. The second volume " $V_2$ " of void space is equal to the volume of the device **130**, or portion thereof, to be disposed within the cut-out area **130**.

In FIG. 4, an assembled configuration of the PCB **100** is shown and includes the first layer stack **102** including the cut-out area **130** defined therethrough and the second layer stack **104** with the device **170** disposed in a first-level configuration within the cut-out area **130**. As it is used in this description, with respect to the cut-out area **130**, "first-level configuration" generally refers to varied configurations wherein the top surface **171** of the device **170** is disposed (e.g., in relation to the first conductive layer **110**) below the level of the second surface **112** of the first conductive layer **110**, such that the peripheral edges of the device **170** do not physically contact the first conductive layer **110**. In other PCB embodiments, "first-level configuration" may be used in the context of other devices (e.g., device **1070** shown in FIGS. 10B, 10C and 11, and device **1370** shown in FIGS. 13 and 14).

In some embodiments, a dielectric material **180** (shown in FIG. 3) may be used to fill, entirely or in part, a volume of void space defined by the cut-out area **130** disposed above (e.g., extending outwardly from) the top surface **171** of the device **170**. Dielectric material **180** may be any suitable material having any suitable dielectric constant.

Cut-out areas in accordance with the present disclosure (e.g., one cut-out area **130** shown in FIG. 3, or two cut-out areas **1303** and **1330** shown in FIG. 13) may be formed by any suitable process, e.g., laser cutting, stamping, punching and/or die-cutting, or any combination of these and other processes, e.g., photo-etching. In some embodiments, one or more cut-out areas may be formed by fineblanking, or a combination of fineblanking and forming operations.

Fineblanking may be used to achieve flatness and cut edge characteristics that may be unobtainable by conventional stamping and punching methods. In general, fineblanking operations require the use of high-pressure pads and are carried out on triple-action hydraulic presses on which the punch, guide plate, and die movements can be controlled individually or simultaneously. The pads hold the part flat during the cutting process and prevent the part from plastically deforming during punch entry. Using fineblanking, a part's cut surface is sheared smoothly over the entire workpiece thickness, with minimal die roll on edges. Achievable part dimensional tolerances may range from about  $\pm 0.0003$  inches to about  $\pm 0.002$  inches, depending upon material thickness, material characteristics (e.g., tensile strength), and part layout. The use of fineblanking processes allows excellent dimensional control, accuracy and repeatability throughout a production run.

In some embodiments, the cut-out area **130** may be characterized as including an outer periphery having a length and a width that is at least marginally larger than the length and width, respectively, of the device **170**, e.g., to allow for ease of assembly of the PCB **100**. In some embodiments, one or more surfaces of the first insulative layer **120** (and/or first conductive layer **110**) disposed adjacent to the outer periphery of the cut-out area **130** may include one or more grooves, slots, pockets, channels or other recesses configured to accommodate and receive therein one or more portions of a device, and/or to allow for air circulation around the device, or portion thereof, to increase heat dissipation. Additionally, or alternatively, a configuration of gap areas, which are described later in this description, may be provided to the first layer stack **102**, e.g., disposed in adjoining relation to the cut-out area **130**, or portion thereof.

In some embodiments, the first electrically-conductive layer **110** of the first stack **102** may be formed, patterned or otherwise deposited on the surface of first insulative layer **120** to avoid or otherwise exclude one or more areas **113** disposed adjacent to the outer periphery of the cut-out area **130**. Alternatively, one or more areas **113** of the surface of first insulative layer **120** may be exposed by removal of one or more portions of the first electrically-conductive layer **110**.

As shown in FIG. 3, a sheet of electrically-conductive material **190** may be provided, and may include a first portion **194** configured to cover the cut-out area **130** when a second portion **195** of the sheet **190** is disposed on either, the first surface **111** of the first conductive layer **110**, or the first surface **121** of the first insulative layer **120**. Electrically-conductive material **190** may include various types of materials in varied configurations, including, without limitation, a conductive tape (e.g., carbon conductive tape or copper conductive tape) or a conductive adhesive sheet (e.g., silver conductive adhesive sheet). In some embodiments, the sheet of electrically-conductive material **190**, or portion thereof (e.g., second portion **195**), may be provided with a suitable adhesive material for affixing, permanently or releaseably, the sheet of electrically-conductive material **190**, or portion thereof, to the first surface **111** of the first conductive layer **110** and/or the first surface **121** of the first insulative layer **120**.

FIG. 5 shows a PCB **500** that includes an asymmetric strip-line transmission line according to an embodiment of the present disclosure. PCB **500** includes a first layer stack **502** and a second layer stack **504**. First layer stack **502** includes a first conductive layer **510** and a first insulative layer **520** upon which the first conductive layer **510** is supported. Second layer stack **504** includes a second conductive layer **550** and a second insulative layer **540**. An electrically-con-

ductive trace **560** is sandwiched by the first and second insulative layers **520** and **540** disposed between the first and second conductive layers **510** and **550**. First conductive layer **510** and second conductive layer **550** are similar to the first conductive layer **110** and the second conductive layer **150**, respectively, shown in FIG. 3 and further description thereof is omitted in the interests of brevity.

First insulative layer **520** and the second portion second insulative layer **540** are similar to the first insulative layer **120** and the second insulative layer **140**, respectively, of PCB **100** shown in FIG. 3, except for the thickness of the first insulative layer **520** in relation to the thickness of the second insulative layer **540**. As shown in FIG. 5, the thickness " $T_{D3}$ " of the first insulative layer **520** is less than the thickness " $T_{D4}$ " of the second insulative layer **540**. Electrically-conductive trace **560** may be disposed on the second insulative layer **540**. Electrically-conductive trace **560** generally includes a thickness " $T_C$ ", an upper surface having a width " $W_{C1}$ ", and a lower surface having a width " $W_{C2}$ ".

FIG. 6 shows an embodiment of a first layer stack **602** including a cut-out area **130** defined therethrough in accordance with the present disclosure. First layer stack **602** generally includes the first conductive layer **110** and the first insulative layer **120** of the first layer stack **102** shown in FIG. 3. First layer stack **602** may have any suitable height " $H_1$ ".

First layer stack **602** is similar to the first layer stack **102** shown in FIG. 3, except for a configuration of gap areas disposed along two opposite sides of the cut-out area **130**, e.g., to simplify physical interconnections and assembly operations (e.g., component placement and soldering) and/or to facilitate inspection and test. As shown in FIGS. 6 and 8, the first layer stack **602** includes a first gap area **632** and a second gap area **634**. First and second gap areas **632** and **634** disposed along two opposite sides of the cut-out area **130** may be configured to allow for removal of the device **170**, e.g., to facilitate the replacement of parts and/or hardware upgrade, and/or to allow for air circulation for heat dissipation purposes. The shape, size and relative positions of the first and second gap areas **632** and **634**, respectively, may be varied from the configuration depicted in FIGS. 6 and 8.

FIG. 7 shows an embodiment of a first layer stack **702** including a cut-out area **130** defined therethrough in accordance with the present disclosure. First layer stack **702** generally includes the first conductive layer **110** and the first insulative layer **120** of the first layer stack **102** shown in FIG. 3. First layer stack **702** may have any suitable height " $H_1$ ".

First layer stack **702** is similar to the first layer stack **102** of PCB **100** shown in FIG. 3, except for a gap area disposed in association with the cut-out area **130**. As shown in FIGS. 7 and 9, the first layer stack **702** includes a gap area **736** disposed around the outer periphery of the cut-out area **130**, e.g., to optimize ease and economy of assembly, inspection, test, and acceptance of components, and/or to enhance electrical isolation of the device **170** from the first conductive layer **110**. The shape and size of the gap area **736** may be varied from the configuration depicted in FIGS. 7 and 9.

FIG. 8 shows a portion of a PCB **800** according to an embodiment of the present disclosure. In FIG. 8, the first layer stack **602** of FIG. 6 including the cut-out area **130** defined therethrough and the second layer stack **104** of FIG. 3 are shown assembled with the device **170** disposed in a first-level configuration within the cut-out area **130**.

FIG. 9 shows a portion of a PCB **900** according to an embodiment of the present disclosure. In FIG. 9, the first layer stack **702** of FIG. 7 including the cut-out area **130** defined therethrough and the second layer stack **104** of FIG. 3 are

shown assembled with the device **170** disposed in a first-level configuration within the cut-out area **130**.

FIG. 10A shows a portion of a PCB **1000** with first and second layer stacks separated according to an embodiment of the present disclosure. PCB **1000** generally includes the first layer stack **702** of FIG. 7 and the second layer stack **104** of FIG. 3. First layer stack **702** has any suitable height " $H_1$ ". First layer stack **702** includes the cut-out area **130** defined therethrough and the gap area **736** surrounding the cut-out area **130**. One or more electrically-conductive traces **160** are disposed (e.g., formed, patterned or otherwise deposited) on the second insulative layer **140** of the second layer stack **104**. Second layer stack **104** has any suitable height " $H_3$ ".

In FIG. 10B, the first layer stack **702** and second layer stack **104** are shown assembled with a device **1070** positioned above the first layer stack **702** for placement into the cut-out area **130** onto the second layer stack **104** according to an embodiment of the present disclosure. Device **1070** generally includes a top surface **1071** and a bottom surface **1073**. Device **1070** includes a height " $H_5$ " defined between the top and bottom surfaces **1071** and **1073**, respectively. Height " $H_5$ " may be any suitable height.

Device **1070** shown in FIGS. 10B and 10C is similar to the device **170** of FIG. 3, except for the height " $H_5$ " of the device **1070**, which is greater than the height " $H_3$ " of the device **170** of FIG. 3, by a height " $H_4$ ". Device **1070** may take a variety of shapes and sizes. In some embodiments, the device **1070** may be mounted, or otherwise disposed on, or adjacent to, the second insulative layer **140** of the second layer stack **104**. Device **1070** may be electrically-coupled to one or more electrically-conductive traces **160** disposed in association with the second insulative layer **140**.

In FIG. 10C, the PCB **1000** of FIG. 10B is shown with the device **1070** disposed in a second-level configuration. As it is used in this description, "second-level configuration", with respect to the device **1070**, generally refers to varied configurations wherein a first portion of the device **1070** is disposed within a cut-out area (e.g., cut-out area **1303** shown in FIGS. 13 and 14) and a second portion including the top surface **1071** is disposed (e.g., in relation to the first conductive layer **110**) outwardly of the first surface **111** and/or the second surface **112** of the first conductive layer **110**. In other PCB embodiments, "second-level configuration" may be used with respect to other devices (e.g., device **170** shown in FIGS. 3, 4, 8, 9, 12, 13, 14 and 15, device **1070** shown in FIGS. 10B, 100 and 11, and device **1370** shown in FIGS. 13 and 14).

As shown in FIG. 100, the top surface **1071** of the device **1070** extends a height " $H_4$ " above the first surface **111** of the first conductive layer **110**, wherein the gap area **736** is configured such that the peripheral edges of the device **1070** do not physically contact the first conductive layer **110**, e.g., to electrically isolate the device **1070** from the first conductive layer **110**.

FIG. 11 shows a PCB **1100** according to an embodiment of the present disclosure that includes the PCB **1000** shown in FIG. 10C. PCB **1100** includes, or is otherwise associated with, a heat sink **1185**. Heat sink **1185** may include one or more heat transfer layers capable of absorbing heat from an object. Heat sink **1185** may be a fluid-cooled heat sink. Heat sink **1185** may include integral sensing elements, and may be used as part of a system to provide a controlled temperature to one or more devices (e.g., device **1070** shown in FIG. 11).

As shown in FIG. 11, at least a portion of the heat sink **1185** is disposed in association with the top surface **1071** of the device **1070**. In some embodiments, the heat sink **1185**, or

portion thereof, may be disposed on a portion of the top surface 1071, or relatively near the top surface 1071 of the device 1070.

FIG. 12 shows a portion of a PCB 1200 with first and second layer stacks separated according to an embodiment of the present disclosure. PCB 1200 includes a first layer stack 1202 and the second layer stack 104 shown in FIG. 3. First layer stack 1202 has a height "H<sub>6</sub>" and generally includes a first conductive layer 1210, a first insulative layer 1220, a prepreg layer 1225, and a cut-out area 1203 defined there-through. First layer stack 1202 may have any suitable height "H<sub>6</sub>". First conductive layer 1210 is similar to the first conductive layer 110 shown in FIG. 3 and further description thereof is omitted in the interests of brevity.

First insulative layer 1220 may be formed from any suitable dielectric or insulating material. First insulative layer 1220 generally includes a first surface 1221 and an opposite second surface 1222. First insulative layer 1220 may include a single layer or multiple layers disposed between the first and second surfaces 1221 and 1222, respectively. First insulative layer 1220 may have any suitable thickness "T<sub>D5</sub>". In some embodiments, the first insulative layer 1220 of the first layer stack 1202 is formed from a material with a dielectric constant different than the dielectric constant of the second insulative layer 140 of the second layer stack 104. In some embodiments, the height "H<sub>6</sub>" of the first layer stack 1202 may be substantially equal to the height "H<sub>3</sub>" of the second layer stack 104.

Prepreg layer 1225 has a thickness "T<sub>D6</sub>" and generally includes a first surface 1227 and an opposite second surface 1226. In some embodiments, as shown in FIG. 12, the first surface 1227 of the prepreg layer 1225 is coupled to the second surface 1222 of the first insulative layer 1220 of the first layer stack 1202. In an alternative embodiment not shown, a prepreg layer may additionally, or alternatively, be coupled to the first surface 141 of the second insulative layer 120 of the second layer stack 104. Thickness "T<sub>D6</sub>" may be any suitable thickness.

Prepreg layer 1225 may be formed from any suitable material. In some embodiments, the prepreg layer 1225 may include one or more layers of FR-2, FR-3, FR-4, FR-5, FR-6, G-10, CEM-1, CEM-2, CEM-3, CEM-4, CEM-5, and/or any suitable epoxy resin composition, fiber-reinforced composite material, and/or other suitable material disposed between the first and second surfaces 1227 and 1226, respectively.

FIG. 13 shows a portion of a PCB 1300 with first and second layer stacks separated according to an embodiment of the present disclosure. PCB 1300 includes a first cut-out area 1303 defined in a first layer stack 1302, and a second cut-out area 1330 defined in a second layer stack 1304. Although only two cut-out areas 1303 and 1330 are shown in FIG. 13 for ease of illustration, it is to be understood that PCB 1300 may include any number of cut-out areas defined in the first layer stack 1302 and/or the second layer stack 1304.

First layer stack 1302 includes the first conductive layer 110 and the first insulative layer 120 shown in FIG. 3. First conductive layer 110 includes a first surface 111 and an opposite second surface 112. First insulative layer 120 includes a first surface 121 and an opposite second surface 122. In some embodiments, the first conductive layer 110 may be either a power plane or a ground plane.

As shown in FIG. 13, a circuit 1376 is disposed in association with the second surface 122 of the first insulative layer 120 of the first layer stack 1302. Circuit 1376 generally includes a device 1370 and one or more electrically-conductive traces 1360 disposed (e.g., formed, patterned, or otherwise deposited) on the second surface 122 of the first insula-

tive layer 120. Circuit 1376 is similar to the circuit 176 shown in FIG. 3 and further description thereof is omitted in the interests of brevity.

Second layer stack 1304 includes a second insulative layer 1340. Second insulative layer 1340 generally includes a first surface 1341 and an opposite second surface 1342. Second insulative layer 1340 may include a single layer, or a plurality of layers, of any suitable dielectric or insulating material disposed between the first and second surfaces 1341 and 1342, respectively. Circuit 176 is disposed in association with the first surface 1341 of the second insulative layer 1340. In some embodiments, as shown in FIG. 13, a second conductive layer 1350 is supported by the second surface 1342 of the second insulative layer 1340. Second conductive layer 1350 generally includes a first surface 1351 and an opposite second surface 1352. In an alternative embodiment not shown, one or more layers of any suitable material may be disposed between the second surface 1342 of the second insulative layer 1340 and the second surface 1352 of the second conductive layer 1350, e.g., to form a bond therebetween. In some embodiments, the second conductive layer 1350 may be either a power plane or a ground plane.

As shown in FIG. 13, the cut-out area 1303 defines a void that extends from the second surface 122 of the first insulative layer 120 to the first surface 111 of the first conductive layer 110 of the first layer stack 1302. Cut-out area 1303 is configured to receive at least a portion of the device 170 therein. In some embodiments, when the second surface 122 of the first insulative layer 120 is coupled to the first surface 1341 of the second insulative layer 1340, the device 170 may be disposed in a first-level configuration within the cut-out area 1303, wherein the top surface 171 of the device 170 is disposed below the level of the second surface 112 of the first conductive layer 110, such that the peripheral edges of the device 170 do not physically contact the first conductive layer 110. In some embodiments, when the second surface 122 of the first insulative layer 120 is coupled to the first surface 1341 of the second insulative layer 1340, the top surface 171 of the device 170 is disposed below the second surface 112 of the first insulative layer 140. In some embodiments, a dielectric material (e.g., dielectric material 180 shown in FIG. 3) may be used to fill, entirely or in part, a volume of void space (e.g., void space "V<sub>1</sub>" shown in FIG. 3) defined by the cut-out area 1303 disposed above, or extending outwardly from, the top surface 171 of the device 170.

In some embodiments, as shown in FIG. 13, the cut-out area 1330 defines a void that extends from the second surface 1342 of the second insulative layer 1340 to the first surface 1351 of the second conductive layer 1350 of the second layer stack 1304. Cut-out area 1330 is configured to receive at least a portion of the device 1370 therein. In some embodiments, when the second surface 122 of the first insulative layer 120 is coupled to the first surface 1341 of the second insulative layer 1340, the device 1370 may be disposed in a first-level configuration within the cut-out area 1303, wherein the top surface 1371 of the device 1370 is disposed below the level of the first surface 1351 of the second conductive layer 1350, e.g., the top surface 1371 of the device 1370 does not extend beyond the second surface 1342 of the second insulative layer 1340.

Cut-out areas 1303 and 1330 may be formed by any suitable process, e.g., laser cutting, stamping, punching and/or die-cutting, or any combination of these and other processes, e.g., photo-etching. In some embodiments, the cut-out area 1303 defined in the first layer stack 1302 and/or the cut-out area 1330 defined in the second layer stack 1304 may be formed by fineblanking, or a combination of fineblanking and

forming operations. After fineblanking (or laser cutting, stamping, punching, die-cutting, etc.), one or more cut-out portions **1380** from the first layer stack **1302** and/or the second layer stack **1304** (e.g., cut-out portion **1380** associated with the cut-out area **1330**) may be retained so as to be available for use as replacement material for filling any volume of void space defined by one or more cut-out areas, e.g., cut-out area **1303** and/or the cut-out area **133**, and/or for minimizing discontinuity in a ground plane (or power plane).

In some cases, one or more cut-out areas defined through the first layer stack **1302** and/or the second layer stack **1304** may not be utilized during PCB assembly (or, later, a component may be removed from the PCB **1300**). In cases such as those, the retained cut-out portions **1380** may be used as replacement material, e.g., to close the opening in the ground plane (or power plane) defined by the cut-out area, thereby minimizing discontinuity in the ground plane (or power plane), e.g., to avoid degrading electrical performance.

In some embodiments, one or more gap areas (e.g., first gap area **632** and/or second gap area **634** shown in FIG. 6, or gap area **736** shown in FIG. 7) disposed in adjoining relation to the cut-out area **1303** may be provided to the first layer stack **1302**. In some embodiments, when the second surface **122** of the first insulative layer **120** of the first layer stack **1302** is coupled to the first surface **1341** of the second insulative layer **1340** of the second layer stack **1304**, the device **170** may be disposed in a second-level configuration, wherein a first portion of the device **170** is disposed within the cut-out area **1303** and a second portion including the top surface **171** of the device **170** is disposed (e.g., in relation to the first conductive layer **110**) outwardly of the first surface **111** and/or the second surface **112** of the first conductive layer **110**.

One or more gap areas (e.g., first gap area **632** and/or second gap area **634** shown in FIG. 6, or gap area **736** shown in FIG. 7) disposed in adjoining relation to the cut-out area **1330** may additionally, or alternatively, be provided to the second layer stack **1304**. In some embodiments, when the second surface **122** of the first insulative layer **120** of the first layer stack **1302** is coupled to the first surface **1341** of the second insulative layer **1340** of the second layer stack **1304**, the device **1370** may be disposed in a second-level configuration, wherein a first portion of the device **1370** is disposed within the cut-out area **1330** and a second portion including the top surface **1371** of the device **1370** is disposed (e.g., in relation to the second conductive layer **1350**) outwardly of the first surface **1351** and/or the second surface **1352** of the second conductive layer **1350**.

FIG. 14 shows a portion of a PCB **1400** with layer stacks separated according to an embodiment of the present disclosure. PCB **1400** includes the first layer stack **1302** shown FIG. 13 including the first cut-out area **1303** defined therethrough and the circuit **1376**. PCB **1400** includes a second layer stack **1404** including a second cut-out area **1430** defined therethrough. Although only two cut-out areas **1303** and **1430** are shown in FIG. 14 for ease of illustration, it is to be understood that PCB **1400** may include any number of cut-areas defined in the first layer stack **1302** and/or the second layer stack **1404**.

Second layer stack **1404** includes a second insulative layer **1440**. Second insulative layer **1440** generally includes a first surface **1441** and an opposite second surface **1442**. Second insulative layer **1440** may include a single layer, or a plurality of layers, of any suitable dielectric or insulating material disposed between the first and second surfaces **1441** and **1442**, respectively. In some embodiments, the second layer stack **1404** includes a second conductive layer **1450** including a first surface **1451** and an opposite second surface **1452**. In

some embodiments, as shown in FIG. 14, second surface **1452** of the second conductive layer **1450** is disposed on the second surface **1442** of the second insulative layer **1440**. In an alternative embodiment not shown, one or more layers of any suitable material may be disposed between the second surface **1442** of the second insulative layer **1440** and the second surface **1452** of the second conductive layer **1450**, e.g., to form a bond therebetween. In some embodiments, the second conductive layer **1450** may be either a power plane or a ground plane.

Second layer stack **1404** includes a prepreg layer **1445** disposed in association with the second insulative layer **1440**. Prepreg layer **1445** generally includes a first surface **1447** and an opposite second surface **1446**. In some embodiments, as shown in FIG. 14, second surface **1446** of the prepreg layer **1445** is disposed on the first surface **1441** of the second insulative layer **1440**. Circuit **176** may be disposed in association with the first surface **1447** of the prepreg layer **1445**. second conductive layer **1350** of FIG. 13 disposed on a first surface **1441** of a second insulative layer **1440**, a prepreg layer **1445** disposed on an opposite second surface **1442** of the second insulative layer **1440**, and a cut-out area **1430** defined therethrough.

As shown in FIGS. 13 and 14, the first layer stack **1302** includes a circuit **1376** disposed in association with a first insulative layer **120**. Circuit **1376** generally includes a device **1370** and one or more strip-lines **1360** disposed on a second surface **122** of the first insulative layer **120**. Cut-out area **1430** defined in the second layer stack **1404** is configured to receive at least a portion of the device **1370** therein.

In some embodiments, the second conductive layer **1350** may be either a power plane or a ground plane. Second insulative layer **1440** may include a single layer, or a plurality of layers, of any suitable dielectric or insulating material disposed between the first and second surfaces **1441** and **1442**, respectively. Second insulative layer **1440** is similar to the second insulative layer **1340** of FIG. 13 and further description thereof is omitted in the interests of brevity.

Prepreg layer **1445** generally includes a first surface **1447** and an opposite second surface **1446**. In some embodiments, as shown in FIG. 14, the second surface **1446** of the prepreg layer **1445** is disposed on the first surface **1441** of the second insulative layer **1440** of the second layer stack **1404**. Prepreg layer **1445** is similar to the prepreg layer **1225** shown in FIG. 12 and further description thereof is omitted in the interests of brevity. In an alternative embodiment not shown, the first layer stack **1302** may additionally, or alternatively, include a prepreg layer, e.g., a prepreg layer (not shown) may be disposed on the second surface **122** of the first insulative layer **120** of the first layer stack **1302**.

PCB **1400** may employ the dielectric material **180** and/or one or more sheets of electrically-conductive material **190** of the PCB embodiment shown in FIG. 3. In some embodiments, dielectric material **180** (FIG. 3) may be used to at least partially fill the void defined by the cut-out area **1303**. In some embodiments, dielectric material **180** may additionally, or alternatively, be used to at least partially fill the void defined by the cut-out area **1430** shown in FIG. 14.

In some embodiments, a first sheet of electrically-conductive material **190** (FIG. 3) may additionally, or alternatively, be disposed over the cut-out area **1303** of the first layer stack **1302** shown in FIG. 14. Additionally, or alternatively, a second sheet of electrically-conductive material **190** may be disposed over the cut-out area **1430** of the second layer stack **1404** shown in FIG. 14.

It is to be understood that the configuration of layers between the circuit **1376** and the first conductive layer **110** of



the first layer stack **1302**, and the configuration of layers between the circuit **176** and the second conductive layer **1350** of the second layer stack **1404**, are merely illustrative and non-limiting examples of layer stack-ups, and that PCB layer stacks including a conductive layer (e.g., ground or power plane) and one or more cut-out areas (e.g., two cut-out areas **1303** and **1430** shown in FIG. **14**) defined therethrough according to embodiments of the present disclosure may utilize many different configurations of layer stack-ups, some with fewer, or additional, layers than depicted in the first and second layer stacks of FIG. **14**.

FIGS. **15** and **16A** show a portion of a PCB **1500** according to an embodiment of the present disclosure. PCB **1500** includes a first layer stack **1603**. First layer stack **1603** includes a first insulative layer **1620** and a first conductive layer **1610**. First layer stack **1603** may include one or more cut-out areas (e.g., cut-out area **1530**) defined therethrough. In some embodiments, the first conductive layer **1610** may be a power plane or a ground plane. First insulative layer **1620** and the first conductive layer **1610** are similar to the first insulative layer **120** and the first conductive layer **110**, respectively, of the first stack layer **102** shown in FIG. **3** and further description thereof is omitted in the interests of brevity.

PCB **1500** includes a second layer stack **1604**. Second layer stack **1604** includes a second insulative layer **1640** and a second conductive layer **1650**. In some embodiments, the second conductive layer **1650** may be a power plane or a ground plane. Second insulative layer **1640** and the second conductive layer **1650** are similar to the second insulative layer **140** and the second conductive layer **150**, respectively, of the second stack layer **104** shown in FIG. **3** and further description thereof is omitted in the interests of brevity. In an alternative embodiment not shown, the second layer stack **1604** includes one or more cut-out areas defined therethrough.

In some embodiments, as shown in FIG. **16A**, first layer stack **1603** includes a third insulative layer **1660** disposed in association with the first conductive layer **1610**. Third insulative layer **1660** may include a single layer, or a plurality of layers, of any suitable dielectric or insulating material. A prepreg layer and/or other suitable material (not shown) may be disposed between the third insulative layer **1660** and the first conductive layer **1610**, e.g., to form a bond therebetween. In an alternative embodiment not shown, the third insulative layer **1660** may be disposed in association with the second conductive layer **1650**.

PCB **1500** includes a first signal layer **115**. In some embodiments, as shown in FIG. **16A**, first signal layer **115** is disposed between the first and second conductive layers **1610** and **1650**, respectively. First signal layer **115** may include any suitable configuration of conductive traces, e.g., three conductive traces **160**, **54** and **51** shown in FIGS. **15** and **16A**. In some embodiments, one or more conductive traces, e.g., traces **160**, **54** and/or **51**, may be formed of one or more strip-line traces disposed on the first signal layer **115**.

In some embodiments, as shown in FIG. **16A**, first signal layer **115** is disposed between the first and second insulative layers **1620** and **1640**, respectively, which, in turn, are disposed between the first and second conductive layers **1610** and **1650**, respectively. First insulative layer **1620** and/or the second insulative layer **1640** may include a single layer, or a plurality of layers, of any suitable dielectric or insulating material. In some embodiments, a prepreg layer (e.g., prepreg layer **1445** shown in FIG. **14**), and/or other suitable material, may be disposed between the first and second insulative layers **1620** and **1640**, respectively, e.g., to form a bond therebetween.

In some embodiments, as shown in FIG. **16A**, the third insulative layer **1660** includes the cut-out area **1530**, and may include one or more gap areas (e.g., gap area **1536** shown in FIGS. **15** and **16A**) disposed in adjoining relation to the cut-out area **1530**. In some embodiments, one or more surfaces of the first insulative layer **1620**, the first conductive layer **1610**, and/or the third insulative layer **1660** disposed adjacent to the outer periphery of the cut-out area **1530** may include one or more grooves, slots, pockets, channels or other recesses (not shown) configured to accommodate and receive therein one or more portions of a device, and/or to allow for air circulation around the device, or portion thereof, to increase heat dissipation.

PCB **1500** includes a second signal layer **215** disposed on, or otherwise associated with, the third insulative layer **1660**. Second signal layer **215** may include any suitable configuration of conductive traces, e.g., six conductive traces **60**, **61**, **62**, **63**, **64** and **65** shown in FIG. **15**. In some embodiments, the conductive traces **60**, **61**, **62**, **63**, **64** and/or **65** may be formed of one or more microstrip traces disposed on the second signal layer **215**. One or more electrical devices, electrical and/or electronic components, and/or connectors may be disposed in association with the second signal layer **215** and/or electrically-coupled to one or more conductive traces disposed on the second signal layer **215**. PCB **1500** may include one or more via holes, e.g., three via holes **70**, **71** and **72**, configured to electrically couple one or more elements of the second signal layer **215** to one or more elements of the first signal layer **115**.

In some embodiments, as shown in FIG. **15**, PCB **1500** includes two devices **1580** and **1581** disposed in association with the second signal layer **215**. Devices **1580** and **1581** may be electrically-coupled to one another by one or more conductive traces, e.g., two conductive traces **62** and **63** disposed on the second signal layer **215**. Additionally, or alternatively, devices **1580** and **1581** may be electrically-coupled to one another by a path including three conductive traces, wherein two conductive traces **64** and **65** are disposed in association with the second signal layer **215** and connected by two via holes **71** and **72**, respectively, to a conductive trace **54** disposed in association with the first signal layer **115**.

PCB **1500** includes the circuit **176** and the device **170** of the PCB embodiments shown in FIG. **3** and FIGS. **12** through **14**. In the embodiment shown in FIGS. **15** and **16A**, the circuit **176** is disposed in association with the first signal layer **115** and electrically-coupled to one or more conductive traces **160** disposed on the first signal layer **115**. Device **1580** may be electrically-coupled to the device **170** by a conductive trace **60** disposed on the first signal layer **115** connected by a via hole **70** to the one or more conductive traces **160**.

As shown in FIG. **16A**, the first layer stack **1603** includes the first conductive layer **1610** disposed between the third insulative layer **1660** and the first insulative layer **1620**, and a cut-out area **1530** defining a void therethrough. PCB **1500** may include a gap area **1536** disposed around the outer periphery of the cut-out area **1530**, e.g., in adjoining relation to the cut-out area **1530**. As best shown in FIG. **15**, device **170** is disposed within the cut-out area **1530**. Cut-out area **1530** generally extends from the first signal layer **115** to an opening **200** defined in the second signal layer **215**. In an alternative embodiment not shown, PCB **1500** may include a plurality of gap areas (e.g., first gap area **632** and second gap area **634** shown in FIG. **6**), e.g., disposed in adjoining relation to the cut-out area **1530**.

FIG. **16B** shows a portion of a PCB **1600** according to an embodiment of the present disclosure. PCB **1600** includes the second layer stack **1604** of the PCB **1500** including the sec-

ond insulative layer **1640** and the second conductive layer **1650** shown in FIG. **16A**. PCB **1600** is similar to the PCB **1500** shown in FIG. **16A**, except that, instead of the first layer stack **1603** of the PCB **1500** shown in FIG. **16A**, the PCB **1600** includes a first layer stack **1602** and a third layer stack **1606**. First layer stack **1602** of the PCB **1600** includes the first insulative layer **1620** and the first conductive layer **1610** shown in FIG. **16A**. First layer stack **1602** further includes a portion of the cut-out area **1530** defining a void that extends from the first signal layer **115** through the first conductive layer **1610**. Third layer stack **1606** of the PCB **1600** includes the third insulative layer **1660** shown in FIG. **16A** disposed in association with the second conductive layer **1650** of the first layer stack **1602**. A prepreg layer and/or other suitable material (not shown) may be disposed between the third insulative layer **1660** and the first conductive layer **1610**. As shown in FIG. **16B**, third layer stack **1606** includes a portion of the cut-out area **1530** defined therethrough.

It is to be understood that the configuration of the first layer stack **1603** of the PCB **1500**, and the configuration of the first layer stack **1602** of the PCB **1600**, are merely illustrative and non-limiting examples of layer stack-ups, and that PCB layer stacks including a conductive layer (e.g., ground or power plane) and one or more cut-out areas (e.g., two cut-out areas **1303** and **1430** shown in FIG. **14**) defining a void extending therethrough according to embodiments of the present disclosure may utilize many different configurations of layer stack-ups, some with fewer, or additional, layer stacks than depicted in the PCB embodiments of FIGS. **15**, **16A** and **16B**.

FIG. **17** shows a portion of a PCB **1700** according to an embodiment of the present disclosure. PCB **1700** includes a first signal layer **315**. PCB **1700** generally includes the first conductive layer **1610**, the second conductive layer **1650**, and the second signal layer **215** of the PCB **1500** shown in FIGS. **15** and **16A**.

First signal layer **315** includes one or more electrically-conductive traces disposed in association with the insulative layer **1740**. One or more electrical devices, electrical and/or electronic components, and/or connectors may be disposed in association with the first signal layer **315** and/or electrically-coupled to one or more conductive traces disposed on the first signal layer **315**. First signal layer **315** may include any suitable configuration of conductive traces, e.g., four conductive traces **1761**, **1762**, **1763** and **1764** shown in FIG. **17**. In some embodiments, the conductive traces **1761**, **1762**, **1763** and/or **1764** may be formed of one or more microstrip traces disposed on the first signal layer **315**. Second signal layer **215** may include any suitable configuration of conductive traces, e.g., six conductive traces **60**, **61**, **62**, **63**, **64** and **65** shown in FIG. **15**. PCB **1700** may include one or more devices (e.g., device **1581**) disposed in operative association with the second signal layer **215** and/or the first signal layer **315**.

PCB **1700** includes an inner or first layer stack **1720** disposed between the first and second conductive layers **1610** and **1650**, respectively. First layer stack **1720** may include one or more layers of any suitable dielectric or insulating material. First layer stack **1720** may include one or more layers of prepreg material (not shown). In an alternative embodiment not shown, first layer stack **1720** may include the first conductive layer **1610** and/or the second conductive layer **1650**.

One or more signal layers may be disposed in association with the first layer stack **1720**. As shown in FIG. **17**, PCB **1700** includes an asymmetric strip-line configuration including two internal signal layers **1716** and **1717** disposed within the inner layer stack **1720**. Asymmetric strip-line impedance calculations may depend on a variety of factors, such as

material properties of the material(s) forming the insulative layers, the configuration of insulative layers, and the configuration of signal layers, among other factors.

PCB **1700** includes a second layer stack **1707** including an insulative layer **1660** disposed in association with the first conductive layer **1610**. Insulative layer **1660** may include a single layer, or a plurality of layers, of any suitable dielectric or insulating material. A prepreg layer and/or other suitable material (not shown) may be disposed between the insulative layer **1660** and the first conductive layer **1610**, e.g., to form a bond therebetween. In an alternative embodiment not shown, wherein the first layer stack **1720** includes the first conductive layer **1610**, the second layer stack **1707** includes the insulative layer **1660**, and may include prepreg and/or other suitable material, e.g., to form a bond between the insulative layer **1660** and the first conductive layer **1610**.

As shown in FIG. **17**, second signal layer **215** is disposed in association with the second layer stack **1707**. One or more metal-filled through-holes, or vias (not shown), may be disposed in association with the insulative layer **1660**, and may be configured to electrically-couple one or more elements of the second signal layer **215** to one or more elements of the internal signal layer **1716** and/or the internal signal layer **1717**.

In some embodiments, as shown in FIG. **17**, PCB **1700** includes a third layer stack **1709** including an insulative layer **1740** disposed in association with the second conductive layer **1650**. In an alternative embodiment not shown, wherein the first layer stack **1720** includes the second conductive layer **1650**, the third layer stack **1709** includes the insulative layer **1740**, and may include prepreg and/or other suitable material, e.g., to form a bond between the insulative layer **1740** and the second conductive layer **1650**.

First signal layer **315** is disposed in association with the second layer stack **1709**. One or more microstrip traces, e.g., four traces **1761**, **1762**, **1763** and **1764**, may be disposed on the insulative layer **1740**, and may route signal, power, and/or ground lines to and from the circuitry disposed in association with the insulative layer **1740**. One or more metal-filled through-holes, or vias (not shown), may be disposed in association with the insulative layer **1740**, and may be configured to electrically-couple one or more elements of the first signal layer **315** to one or more elements of the internal signal layer **1716** and/or the internal signal layer **1717**.

Hereinafter, methods of manufacturing a PCB in accordance with the present disclosure are described with reference to FIGS. **18** through **26**. It is to be understood that the steps of the methods provided herein may be performed in combination and in a different order than presented herein without departing from the scope of the disclosure. In the methods of manufacturing printed circuit boards provided herein, the “first” layer stack **102** shown in FIG. **3** may be referred to as “second” layer stack **102** and the “second” layer stack **104** of FIG. **3** may be referred to as “first” layer stack **104**, for ease of explanation.

FIG. **18** is a flowchart illustrating a method (shown generally as **1800** in FIG. **18**) of manufacturing a PCB in accordance with an embodiment of the present disclosure. In step **1810**, a first layer stack **104** is provided. First layer stack **104** includes a first electrically-insulating layer **140**. First electrically-insulating layer **140** includes a first surface **141** and one or more electrically-conductive traces **160** disposed on the first surface **141**.

In step **1820**, a second layer stack **102** is provided. Second layer stack **102** includes a second electrically-insulating layer **120** and a first electrically-conductive layer **110**. The second electrically-insulating layer **120** includes a first surface **121**

and an opposite second surface **122**. First electrically-conductive layer **110** may be disposed on the first surface **121** of the second electrically-insulating layer **120**. Alternatively, a prepreg layer and/or other suitable material (not shown) may be disposed between the first surface **121** of second electrically-insulating layer **120** and the first electrically-conductive layer **110**, e.g., to form a bond therebetween.

Second layer stack **102** includes a cut-out area **130** defining a void that extends therethrough. Cut-out area **130** is configured to receive therein at least a portion of a device **170** to be coupled to the first surface **141** of the first electrically-insulating layer **140** and/or electrically-coupled to one or more of the one or more electrically-conductive traces **160**.

In step **1830**, the first surface **141** of the first electrically-insulating layer **140** is coupled to the second surface **122** of the second electrically-insulating layer **120**. The step **1830** may include the step of orienting the first layer stack **104** and the second layer stack **102** in relation to one another such that the first surface **141** of the first electrically-insulating layer **140** opposes the second surface **122** of the second electrically-insulating layer **120**. The step **1830** may further include positioning the first layer stack **104** and the second layer stack **102** in relation to one another such that the cut-out area **130** is positioned to receive at least a portion of the device **170** therein when the first surface **141** of the first electrically-insulating layer **140** is placed in contact with the second surface **122** of the second electrically-insulating layer **120**.

The above-described method **1800** of manufacturing a PCB may additionally include the step of mounting the device **170** on the first layer stack **104**. The mounting step may include the step of electrically-coupling the device **170** to one or more of the one or more electrically-conductive traces **160**.

In some embodiments, the above-described method **1800** of manufacturing a PCB may additionally, or alternatively, include one or more of the steps shown in FIG. **21**, FIG. **22** and/or FIG. **23**, which are described later in this description.

The above-described method **1800** of manufacturing a PCB may additionally include the step of coupling a third layer stack (e.g., third layer stack **1606** shown in FIG. **16B**, or third layer stack **1709** shown in FIG. **17**) to the first layer stack **104** (or the second layer stack **102**). The third layer stack may include a third electrically-insulating layer (e.g., **1660** shown in FIG. **16B**) and a signal layer **215** disposed in association with a first surface of the third electrically-insulating layer.

FIG. **19** is a flowchart illustrating a method (shown generally as **1900** in FIG. **19**) of manufacturing a PCB in accordance with an embodiment of the present disclosure. In step **1910**, a first layer stack **102** is provided. First layer stack **102** includes a first electrically-conductive layer **110** and a first electrically-insulating layer **120**. First electrically-insulating layer **120** includes a first surface **121** and an opposite second surface **122**. First electrically-conductive layer **110** is disposed on the first surface **121** of the first electrically-insulating layer **120**.

In step **1920**, a second layer stack **104** is provided. The second layer stack **104** includes a second electrically-insulating layer **140**. Second electrically-insulating layer **140** includes one or more electrically-conductive traces **160** disposed on a first surface **141** thereof.

In step **1930**, a device **170** is mounted on the first surface **141** of the second electrically-insulating layer **140** such that the device **170** is electrically-coupled to at least one of the one or more electrically-conductive traces **160**.

In step **1940**, the first layer stack **102** is provided with a cut-out area **130** defining a void that extends from the second surface **122** of the first electrically-insulating layer **120** to the first surface **111** of the first electrically-conductive layer **110**.

Cut-out area **130** is configured to receive at least a portion of the device **170** therein.

In step **1950**, the first surface **141** of the second electrically-insulating layer **140** is brought in contact with the second surface **122** of the first electrically-insulating layer **120** such that at least a portion of the device **170** is disposed within at least a portion of the cut-out area **130**.

In some embodiments, the above-described method (shown generally as **1900** in FIG. **19**) may include one or more of the additional steps shown in FIG. **21**.

FIG. **20** is a flowchart illustrating a method of manufacturing a PCB in accordance with an embodiment of the present disclosure. In step **2010**, a first electrically-insulating layer **120** is provided. First electrically-insulating layer **120** includes a first surface **121** and an opposite second surface **122**.

In step **2020**, a first electrically-conductive layer **110** is provided on the first surface **121** of the first electrically-insulating layer **120**.

In step **2030**, a cut-out area **130** is provided that defines a void that extends from the second surface **122** of the first electrically-insulating layer **120** to the first surface **111** of the first electrically-conductive layer **110**.

In step **2040**, a second electrically-insulating layer **140** is provided that includes a first surface **141** and an opposite second surface **142**.

In step **2050**, a second electrically-conductive layer **150** is provided on the second surface **142** of the second electrically-insulating layer **140**.

In step **2060**, one or more electrically-conductive traces **160** are provided on the first surface **141** of the second electrically-insulating layer **140**.

In step **2070**, a device **170** is mounted on the first surface **141** of the second electrically-insulating layer **140** such that the device **170** is electrically-coupled to at least one of the one or more electrically-conductive traces **160**.

In step **2080**, the second surface **122** of the first electrically-insulating layer **120** is placed in contact with the first surface **141** of the second electrically-insulating layer **140** such that at least a portion of the device **170** is disposed within at least a portion of the cut-out area **130**.

In some embodiments, the above-described method (shown generally as **2000** in FIG. **20**) may include one or more of the additional steps shown in FIGS. **21**, **22** and/or **23**.

FIG. **21** is a flowchart illustrating steps of a method for manufacturing a PCB in accordance with an embodiment of the present disclosure. In step **2110**, a determination is made whether there remains any portion (e.g., volume) of the void defined by the cut-out area **130** extending outwardly from (e.g., above) the device **170**.

In step **2120**, if it is determined that there remains a volume of the void defined by the cut-out area **130** above the device **170**, then a determination is made whether the volume of the void defined by the cut-out area **130** above the device **170** is to be at least partially filled with a dielectric material **180** other than a vacuum or a gas (or mixture of gases, such as air).

In step **2130**, if it is determined that the volume of the void defined by the cut-out area **130** above the device **170** is to be at least partially filled with a dielectric material **180** other than a vacuum or a gas or a gas mixture, then at least partially filling the volume of the void with the dielectric material other than a vacuum or a gas or a mixture of gases.

In some embodiments, the above-described method (shown generally as **2100** in FIG. **21**) may include one or more of the additional steps shown in FIG. **22** and/or FIG. **23**.

FIG. 22 is a flowchart illustrating steps of a method for manufacturing a PCB in accordance with an embodiment of the present disclosure. In step 2210, a sheet of electrically-conductive material is provided. The sheet of electrically-conductive material 190 includes a first portion 194 configured to cover the cut-out area 130 when a second portion 195 of the sheet of electrically-conductive material 190 is disposed on the first surface 111 of the first electrically-conductive layer 110. In some embodiments, the sheet of electrically-conductive material 190 may be a conductive tape, e.g., carbon conductive tape, copper conductive tape, silver conductive adhesive sheet.

In step 2220, the second portion 195 of the sheet of the electrically-conductive material 190 is coupled to at least a portion of the first surface 111 of the first electrically-conductive layer 110. In some embodiments, prior to the step 2220, an area 113 of the first electrically-conductive layer 110, e.g., a portion adjacent to the outer peripheral edges of the cut-out area 130, may be removed, e.g., photo-etched. In some embodiments, the first electrically-conductive layer 110 of the first stack 102 may be formed, patterned or otherwise deposited to eschew the area 113, e.g., to reduce assembly steps and/or fabrication costs, in which case the second portion 195 of the sheet of electrically-conductive material 190 may be coupled to the first surface 121 of the first electrically-insulating layer 120.

In some embodiments, the above-described method (shown generally as 2200 in FIG. 22) may include one or more of the additional steps shown in FIG. 23.

FIG. 23 is a flowchart illustrating steps of a method for manufacturing a PCB in accordance with an embodiment of the present disclosure. In step 2310, a third electrically-insulating layer 1660 is provided. Third electrically-insulating layer 1660 includes a first surface 1661 and an opposite second surface 1662.

In step 2320, the second surface 1662 of the third electrically-insulating layer 1660 is placed in contact with the first surface 111 of the first electrically-conductive layer 110 or the first surface 151 of the second electrically-conductive layer 150.

In step 2330, one or more electrically-conductive traces 62, 63 are provided on the first surface 1661 of the third electrically-insulating layer 1660.

FIG. 24 is a flowchart illustrating steps of a method for manufacturing a PCB in accordance with an embodiment of the present disclosure. In step 2410, a third electrically-insulating layer 1660 is provided. Third electrically-insulating layer 1660 includes a first surface 1661 and an opposite second surface 1662.

In step 2420, the second surface 1662 of the third electrically-insulating layer 1660 is placed in contact with the first surface 151 of the second electrically-conductive layer 150.

In step 2430, one or more electrically-conductive traces 62, 63 are provided on the first surface of the third electrically-insulating layer 1660.

FIG. 25 is a flowchart illustrating steps of a method for manufacturing a PCB in accordance with an embodiment of the present disclosure. In step 2510, a first layer stack 702 and a second layer stack 104 are provided. The first layer stack 1603 includes a first electrically-conductive layer 1610 and first and third electrically-insulating layers 1620 and 1660, respectively, disposed on opposite sides of the first electrically-conductive layer 1610. The second layer stack 1604 includes a second electrically-insulating layer 1640 having a first surface 1641 and an opposite second surface 1642 and a

second electrically-conductive layer 1640 disposed on the second surface 1642 of the second electrically-insulating layer 1650.

In step 2520, a device 170 or 1070 is provided on the first surface 1641 of the second electrically-insulating layer 1640 such that the device 170 or 1070 is electrically-coupled to one or more of the one or more electrically-conductive traces 160 disposed on the first surface 1641 of the second electrically-insulating layer 1640.

In step 2530, the first layer stack 1603 is provided with a cut-out area 1530 defining a void that extends from an outer surface of the first electrically-insulating layer 1620 to an outer surface 1661 of third electrically-insulating layer 1660. The cut-out area 1530 is configured to receive at least a portion of the device 170 or 1070 therein.

In step 2540, the first surface 1641 of the second electrically-insulating layer 1640 is placed in contact with the outer surface of the first electrically-insulating layer 1620 such that at least a portion of the device 170 or 1070 is disposed within at least a portion of the cut-out area 1530.

FIG. 26 is a flowchart illustrating steps of a method for manufacturing a PCB in accordance with an embodiment of the present disclosure. In step 2610, a pattern of one or more electrically-conductive traces 62, 63 is provided on one or more areas of the outer surface 1661 of the third electrically-insulating layer 1660. The one or more areas are spaced apart from the cut-out area 1530.

In step 2620, one or more devices 1581 are provided on the outer surface 1661 of the third electrically-insulating layer 1660 such that one or more of the one or more devices 1581 is electrically-coupled to one or more of the one or more electrically-conductive traces 62, 63 disposed on the outer surface 1661 of the third electrically-insulating layer 1660.

Various embodiments of the above-disclosed PCBs include at least one layer stack that includes an electrically-conductive layer (e.g., a ground plane or a power plane), an electrically-insulating layer, and one or more cut-out areas defining a void that extends therethrough.

Providing PCBs including one or more layer stacks that include one or more cut-out areas configured to receive at least a portion of a device therein according to embodiments of the present disclosure may allow for modularity in the design of PCBs and/or may allow for ease of assembly, e.g., allowing for electrical connection of the device(s) to one or more signal layers.

Various embodiments of the presently-disclosed PCBs including one or more cut-out areas defined in one or more layer stacks may be suitable for use in a variety of PCB applications across a wide range of industries, e.g., the medical, military, aerospace, telecommunication, and automotive industries, in a broad spectrum of technologies.

Although embodiments have been described in detail with reference to the accompanying drawings for the purpose of illustration and description, it is to be understood that the inventive processes and apparatus are not to be construed as limited thereby. It will be apparent to those of ordinary skill in the art that various modifications to the foregoing embodiments may be made without departing from the scope of the disclosure.

What is claimed is:

1. A multi-layer printed circuit board (PCB), comprising:
  - a first layer stack including a first electrically-insulating layer, a second electrically-insulating layer, and a first electrically-conductive layer disposed between the first and second electrically-insulating layers;
  - a second layer stack coupled to the first layer stack, the second layer stack including a third electrically-insulat-

ing layer and a second electrically-conductive layer, wherein at least one of the first layer stack or the second layer stack includes a cut-out area defining a void that extends therethrough;

a first signal layer disposed in association with one of the first electrically-insulating layer of the first layer stack and the third electrically-insulating layer of the second layer stack;

a second signal layer disposed in association with the second electrically-insulating layer of the first layer stack;

a device at least partially disposed within the cut-out area and electrically-coupled to at least one of the first signal layer and the second signal layer; and

a sheet of electrically-conductive material including a first portion covering the cut-out area and a second portion disposed on at least a portion of one of the first electrically-conductive layer and the second electrically-conductive layer, wherein the sheet of electrically-conductive material is disposed in spaced relation relative to a top surface of the device.

2. The PCB of claim 1, wherein the cut-out area is configured to receive therein at least a portion of the device.

3. The PCB of claim 1, further comprising one or more gap areas disposed in adjoining relation to the cut-out area.

4. The PCB of claim 3, wherein the one or more gap areas are configured to physically isolate the device from one of the first electrically-conductive layer and the second electrically-conductive layer.

5. The PCB of claim 3, wherein the one or more gap areas are configured to electrically isolate the device from one of the first electrically-conductive layer and the second electrically-conductive layer.

6. The PCB of claim 1, wherein the void defined by the cut-out area includes a first volume of void space defined between a top surface of the device and a plane containing an outer surface of one of the first electrically-conductive layer and the second electrically-conductive layer.

7. The PCB of claim 6, further comprising dielectric material disposed in at least a portion of the first volume of void space.

8. A method of manufacturing a printed circuit board (PCB), comprising the steps of:

providing first and second layer stacks, the first layer stack including a first electrically-conductive layer and first and third electrically-insulating layers disposed on first and second surfaces of the first electrically-conductive layer, the second layer stack including a second electrically-insulating layer having a first surface and an opposite second surface, the second layer stack further including a second electrically-conductive layer disposed on the second surface of the second electrically-insulating layer;

providing a device on the first surface of the second electrically-insulating layer such that the device is electrically-coupled to at least one of one or more electrically-

conductive traces disposed on the first surface of the second electrically-insulating layer;

providing the first layer stack with a cut-out area defining a void that extends from an outer surface of the first electrically-insulating layer to an outer surface of third electrically-insulating layer, the cut-out area configured to receive at least a portion of the device therein;

placing the first surface of the second electrically-insulating layer in contact with the outer surface of the first electrically-insulating layer such that at least a portion of the device is disposed within at least a portion of the cut-out area; and

providing a sheet of electrically-conductive material including a first portion to cover the cut-out area when a second portion of the sheet of electrically-conductive material is disposed on the first surface of the first electrically-conductive layer, the first portion of the sheet of electrically-conductive material disposed in spaced relation relative to a top surface of the device.

9. The method of manufacturing a PCB of claim 8, wherein a height of the device is greater than a height of the first layer stack.

10. The method of manufacturing a PCB of claim 8, further comprising the steps of providing a heat sink disposed in association with the top surface of the device.

11. The method of manufacturing a PCB of claim 8, further comprising the steps of:

providing a pattern of one or more electrically-conductive traces on one or more areas of the outer surface of the third electrically-insulating layer, the one or more areas spaced apart from the cut-out area; and

providing one or more devices on the outer surface of the third electrically-insulating layer such that at least one of the one or more devices is electrically-coupled to at least one of the one or more electrically-conductive traces disposed on the outer surface of the third electrically-insulating layer.

12. The method of manufacturing a PCB of claim 8, further comprising the step of coupling the second portion of the sheet of the electrically-conductive material to at least a portion of the first surface of the first electrically-conductive layer.

13. The method of manufacturing a PCB of claim 8, further comprising the steps of:

removing an area of the first electrically-conductive layer adjacent to outer peripheral edges of the cut-out area to form an exposed portion of the outer surface of the first electrically-insulating layer; and

coupling the second portion of the sheet of the electrically-conductive material to the exposed portion of the outer surface of the first electrically-insulating layer.