

(12) **United States Patent**
Ullrich et al.

(10) **Patent No.:** **US 8,761,915 B2**
(45) **Date of Patent:** ***Jun. 24, 2014**

(54) **SYSTEM AND METHOD FOR
AUTOMATICALLY PRODUCING HAPTIC
EVENTS FROM A DIGITAL AUDIO FILE**

(75) Inventors: **Christopher J. Ullrich**, Ventura, CA
(US); **Stephen D. Rank**, San Jose, CA
(US); **Munibe M. Bakircioglu**, San
Jose, CA (US)

(73) Assignee: **Immersion Corporation**, San Jose, CA
(US)

(*) Notice: Subject to any disclaimer, the term of this
patent is extended or adjusted under 35
U.S.C. 154(b) by 383 days.

This patent is subject to a terminal dis-
claimer.

(21) Appl. No.: **13/097,661**

(22) Filed: **Apr. 29, 2011**

(65) **Prior Publication Data**

US 2011/0215913 A1 Sep. 8, 2011

Related U.S. Application Data

(63) Continuation of application No. 12/140,133, filed on
Jun. 16, 2008, now Pat. No. 8,000,825, which is a
continuation-in-part of application No. 11/515,243,
filed on Aug. 31, 2006, now Pat. No. 8,378,964.

(60) Provisional application No. 60/792,137, filed on Apr.
13, 2006.

(51) **Int. Cl.**
G06F 17/00 (2006.01)

(52) **U.S. Cl.**
USPC **700/94; 340/407.1**

(58) **Field of Classification Search**
USPC 700/94; 381/56, 61, 118; 340/407.1,
340/407.2; 704/205; 84/609

See application file for complete search history.

(56) **References Cited**

U.S. PATENT DOCUMENTS

4,334,280 A 6/1982 McDonald
4,355,348 A 10/1982 Williams

(Continued)

FOREIGN PATENT DOCUMENTS

EP 1411424 A2 4/2004
JP 10506508 A 6/1998

(Continued)

OTHER PUBLICATIONS

Gillespie, Brent, "The Virtual Piano Action: Design and Implemen-
tation," Center for Computer Research in Music and Acoustics, 1994,
4 pages.

(Continued)

Primary Examiner — Joseph Saunders, Jr.

(74) *Attorney, Agent, or Firm* — Miles & Stockbridge P.C.

(57) **ABSTRACT**

In an embodiment, a system and method for automatically
converting a plurality of events in a plurality of channels in a
structured representation sequence into haptic events. The
method comprises calculating an event score for each event of
the sequence in one or more channels. The method also com-
prises calculating a cumulative score based on the event
scores in the one or more channels. The method includes
selectively designating haptic events to the events based on
the event scores in one or more selected channels, wherein the
haptic events are output by a haptic actuator. This may be
done by the system by calculating properties of the sound or
by taking already existing values associated with those prop-
erties to efficiently produce haptic events.

27 Claims, 14 Drawing Sheets

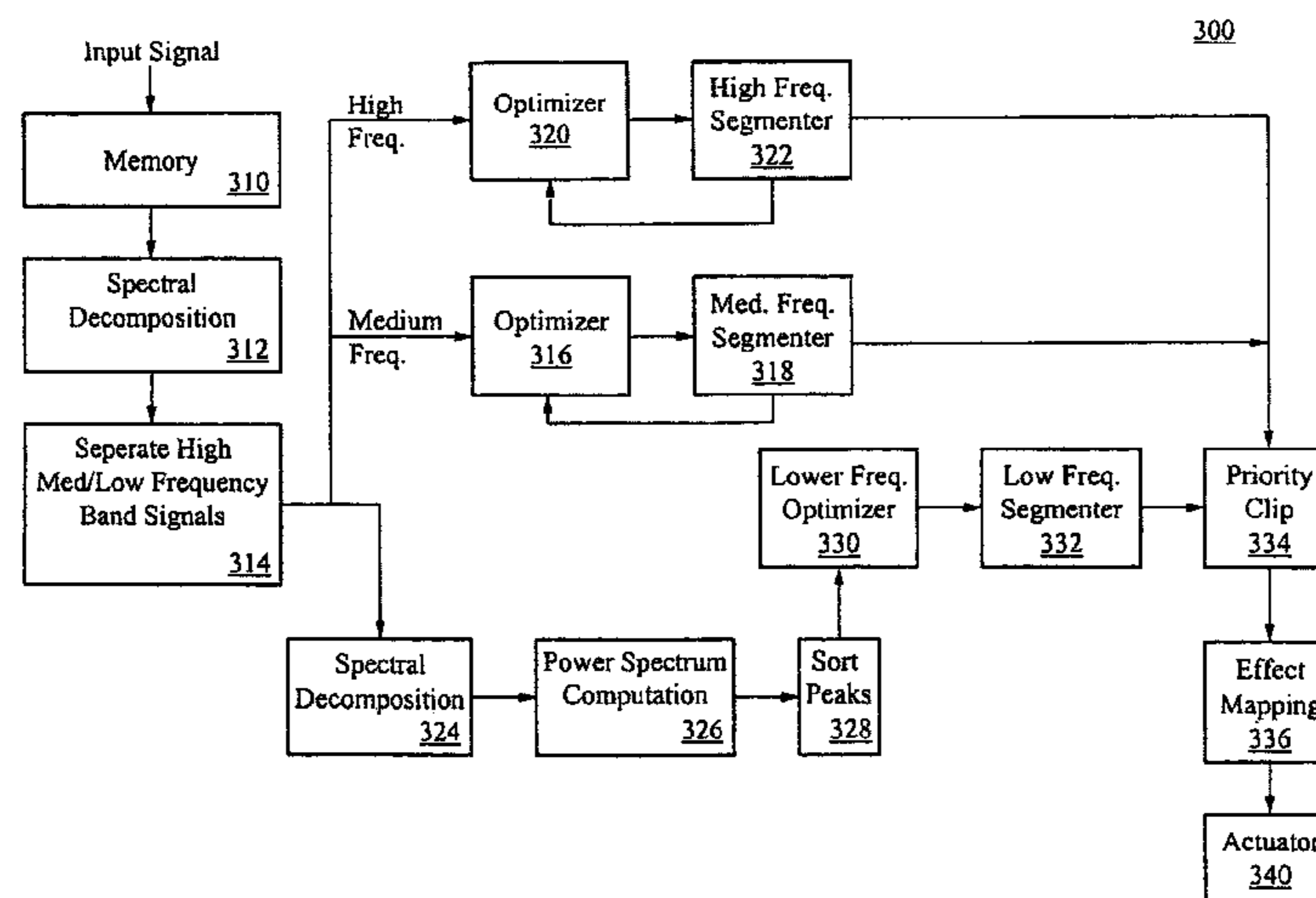

(56)

References Cited

U.S. PATENT DOCUMENTS

4,768,412 A 9/1988 Sanderson
 5,388,992 A 2/1995 Franklin et al.
 5,437,608 A 8/1995 Cutler
 5,438,529 A 8/1995 Rosenberg et al.
 5,532,936 A 7/1996 Perry
 5,669,818 A 9/1997 Thorner et al.
 5,684,722 A 11/1997 Thorner et al.
 5,816,823 A 10/1998 Naimark et al.
 5,842,162 A 11/1998 Fineberg
 6,140,568 A 10/2000 Kohler
 6,160,489 A 12/2000 Perry et al.
 6,191,349 B1 2/2001 Flam
 6,285,351 B1 9/2001 Chang et al.
 6,292,776 B1 9/2001 Chengalvarayan
 6,496,115 B2 12/2002 Arakawa
 6,703,550 B2 3/2004 Chu
 6,885,876 B2 4/2005 Aaltonen et al.
 6,963,762 B2 11/2005 Kaaresoja et al.
 7,623,114 B2 11/2009 Rank
 7,979,146 B2 * 7/2011 Ullrich et al. 700/94
 8,000,825 B2 * 8/2011 Ullrich et al. 700/94
 8,441,437 B2 * 5/2013 Rank 345/156
 2002/0178012 A1 11/2002 Wang et al.
 2003/0067440 A1 4/2003 Rank
 2004/0161118 A1 8/2004 Chu
 2004/0164971 A1 8/2004 Hayward et al.
 2004/0172240 A1 9/2004 Crockett et al.
 2004/0237758 A1 12/2004 Bruti et al.
 2005/0149339 A1 7/2005 Tanaka et al.

2005/0190199 A1 9/2005 Brown et al.
 2006/0129719 A1 6/2006 Cruz-Hernandez et al.
 2010/0066512 A1 3/2010 Rank
 2011/0191674 A1 8/2011 Rawley et al.

FOREIGN PATENT DOCUMENTS

JP 11038865 A 2/1999
 JP 2004-528599 A 9/2004
 JP 2005-506613 A 3/2005
 WO 9917850 4/1999
 WO 03032289 A1 4/2003
 WO 2007120765 A2 10/2007

OTHER PUBLICATIONS

Kirman, Jacob H., "Tactile Perception of Computer-Derived Formant Patterns From Voiced Speech," J. Acoust. Soc. Am., vol. 55, No. 1, Jan. 1974, pp. 163-169.
 "VibeTonz System", Immersion Corporation, 2004, pp. 1-6.
 "VibeTonz Mobile Player", Immersion Corporation, 2005, 4 pages.
 "VibeTonz Solution for BREW Developers", Immersion Corporation, 2005, 2 pages.
 "VibeTonz Studio SDK", Immersion Corporation, 2005, 4 pages.
 Reed, Charlotte M. et al., "Research on Tactile Communication of Speech: A Review," ASHA Monographs, No. 20, 1982, pp. 1-23.
 Official Communication issued in the corresponding EP Application No. 09162711.7 mailed May 12, 2010.
 Search Report issued in the corresponding EP Application No. 09162711.7, completed on May 6, 2010.

* cited by examiner

The musical score is presented in two systems. The first system, labeled '100' with an arrow, consists of two staves: a tenor clef staff on top and a bass clef staff on the bottom. The tenor staff contains ten measures of music, each starting with an accent (^) and featuring a guitar chord diagram. The bass staff contains corresponding notes, with chord markings $B\flat$, C, $B\flat$, C, $B\flat$, C, $B\flat$, C, $B\flat$, and C below the staff. The second system, labeled '10♯ Code', also has two staves. The tenor staff contains ten measures of music with various notes and accents, including a measure with a circled $B\flat$. The bass staff contains notes with chord markings $B\flat$, C, $B\flat$, $D\flat$, $G\flat$, $B\flat$, $D\flat$, $G\flat$, $B\flat$, and C below the staff.

Fig. 1

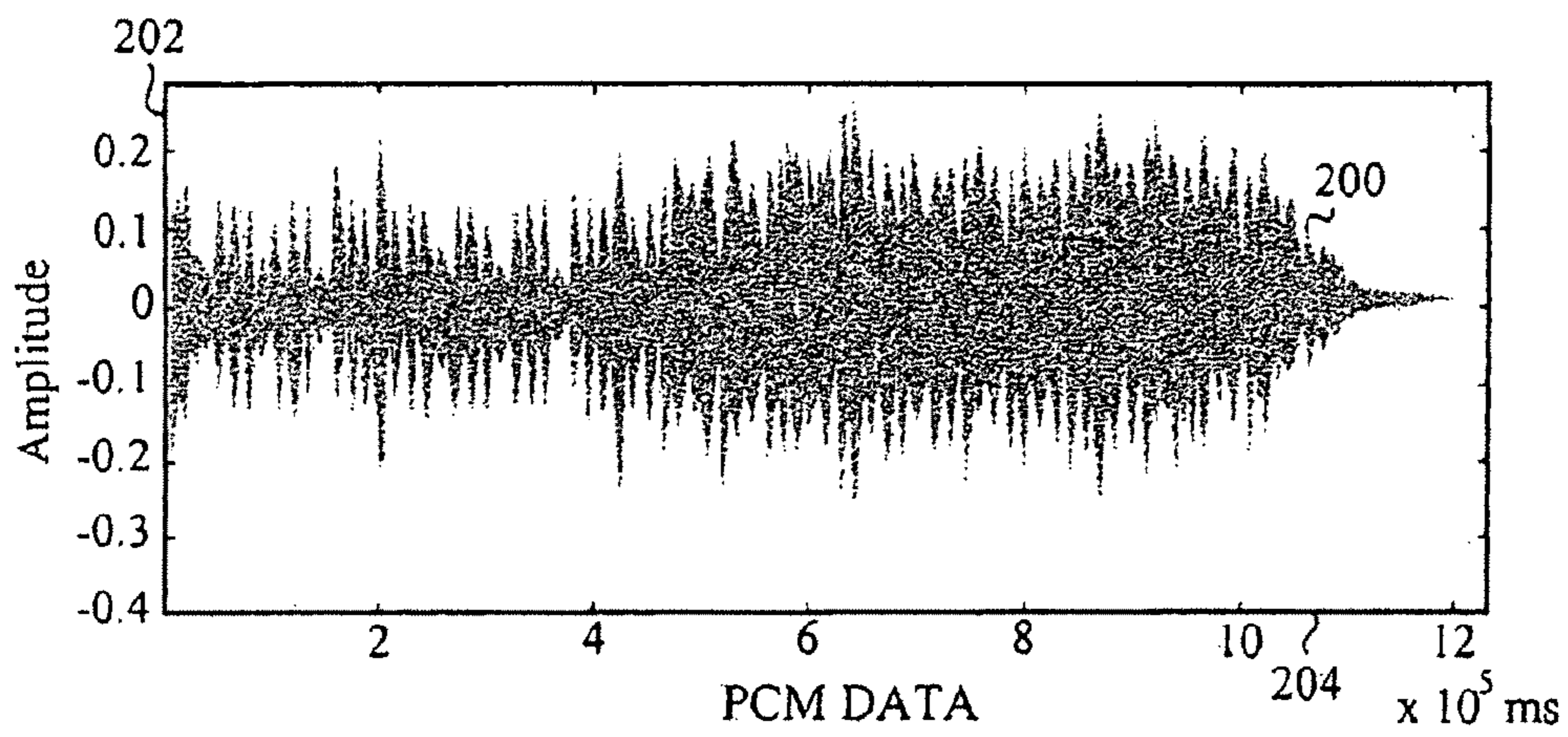

Fig. 2

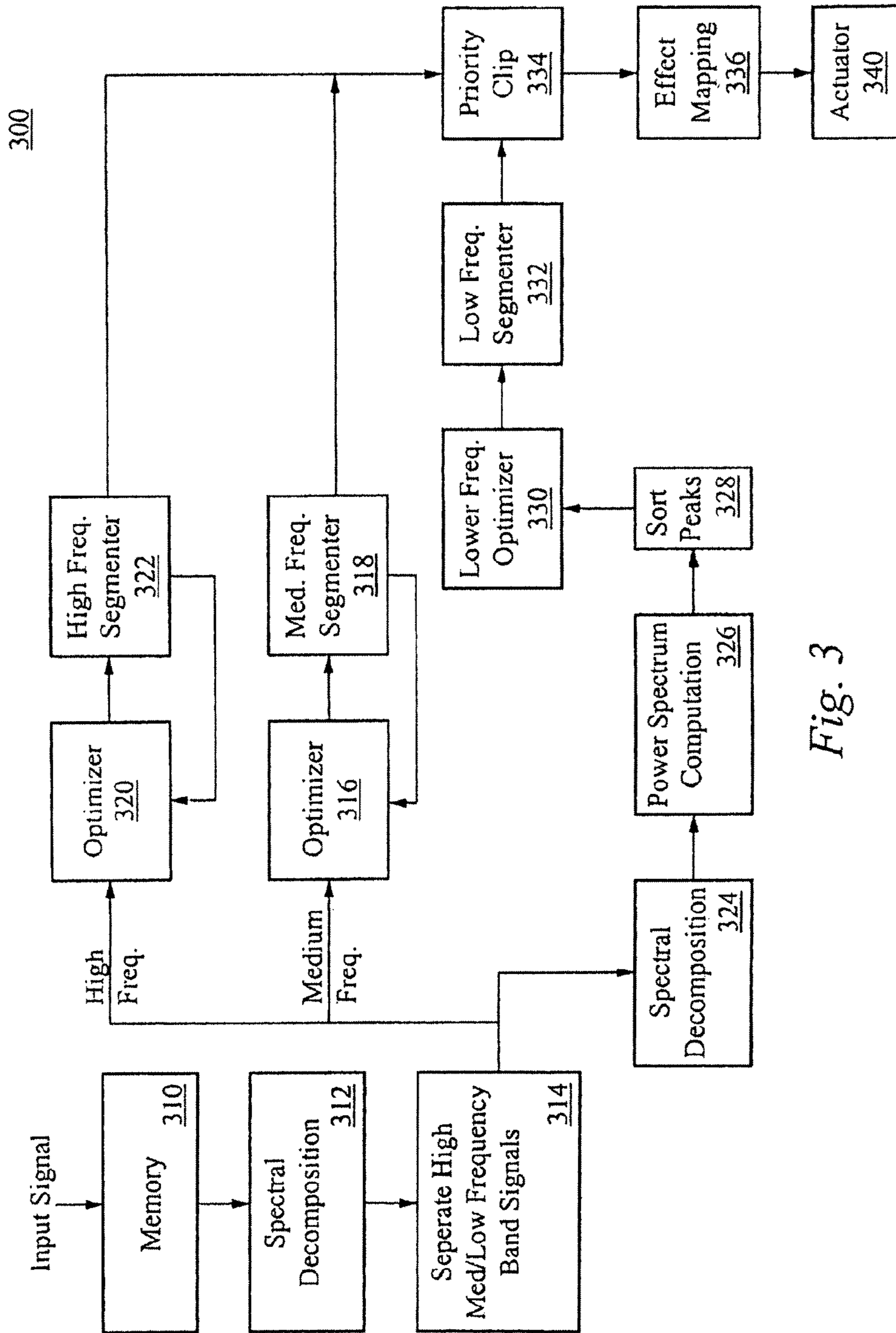

Fig. 3

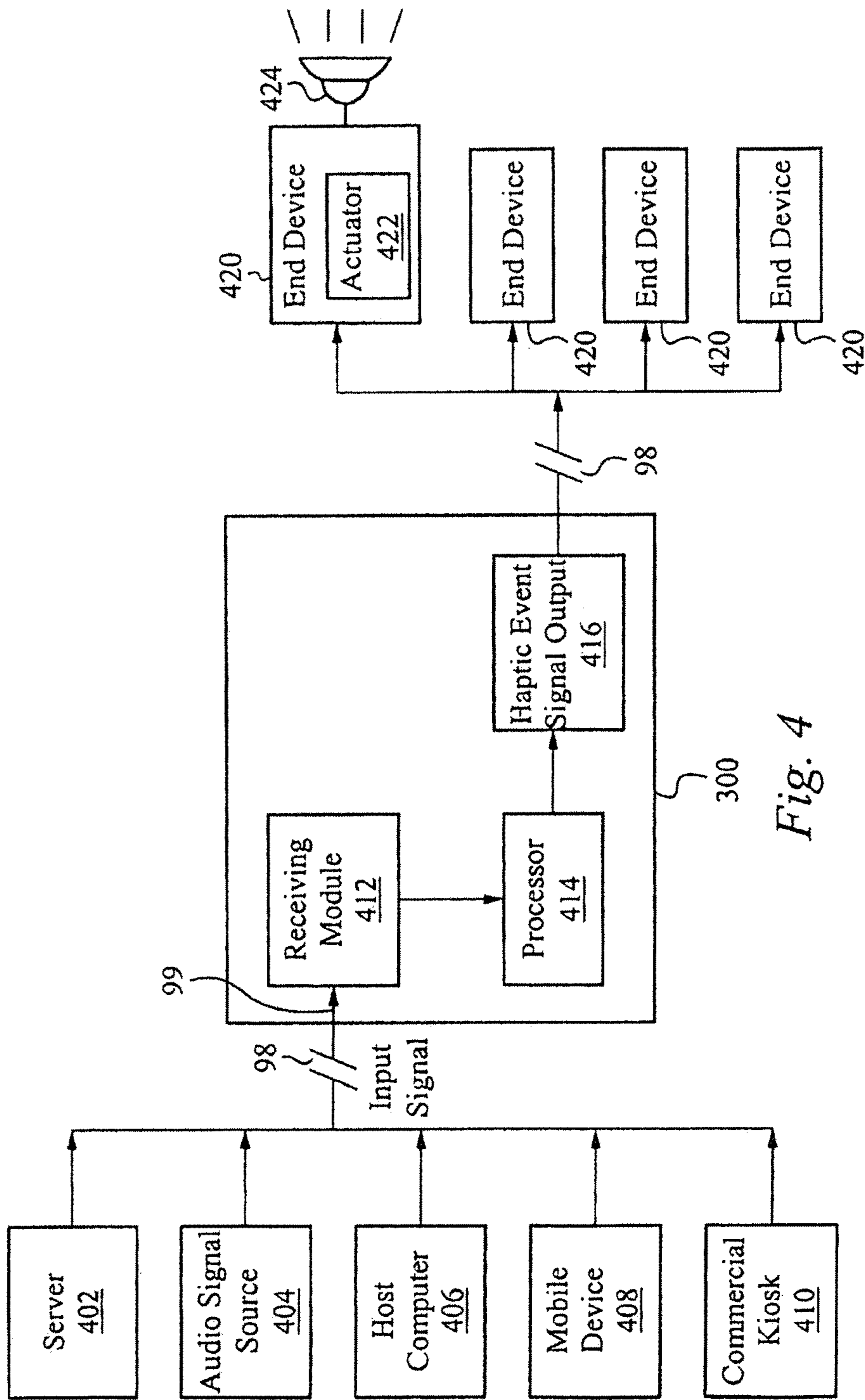

Fig. 4

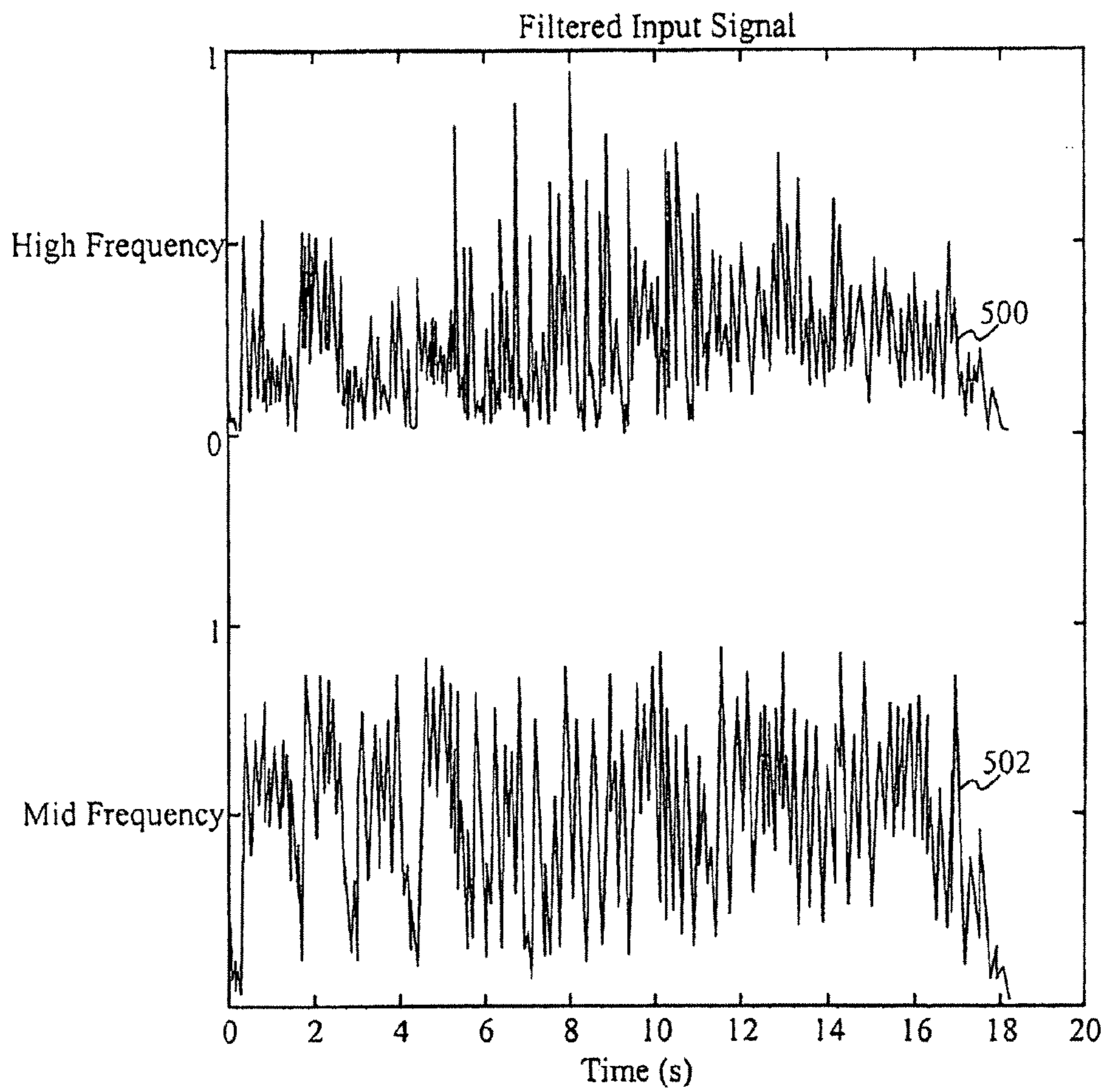

Fig. 5

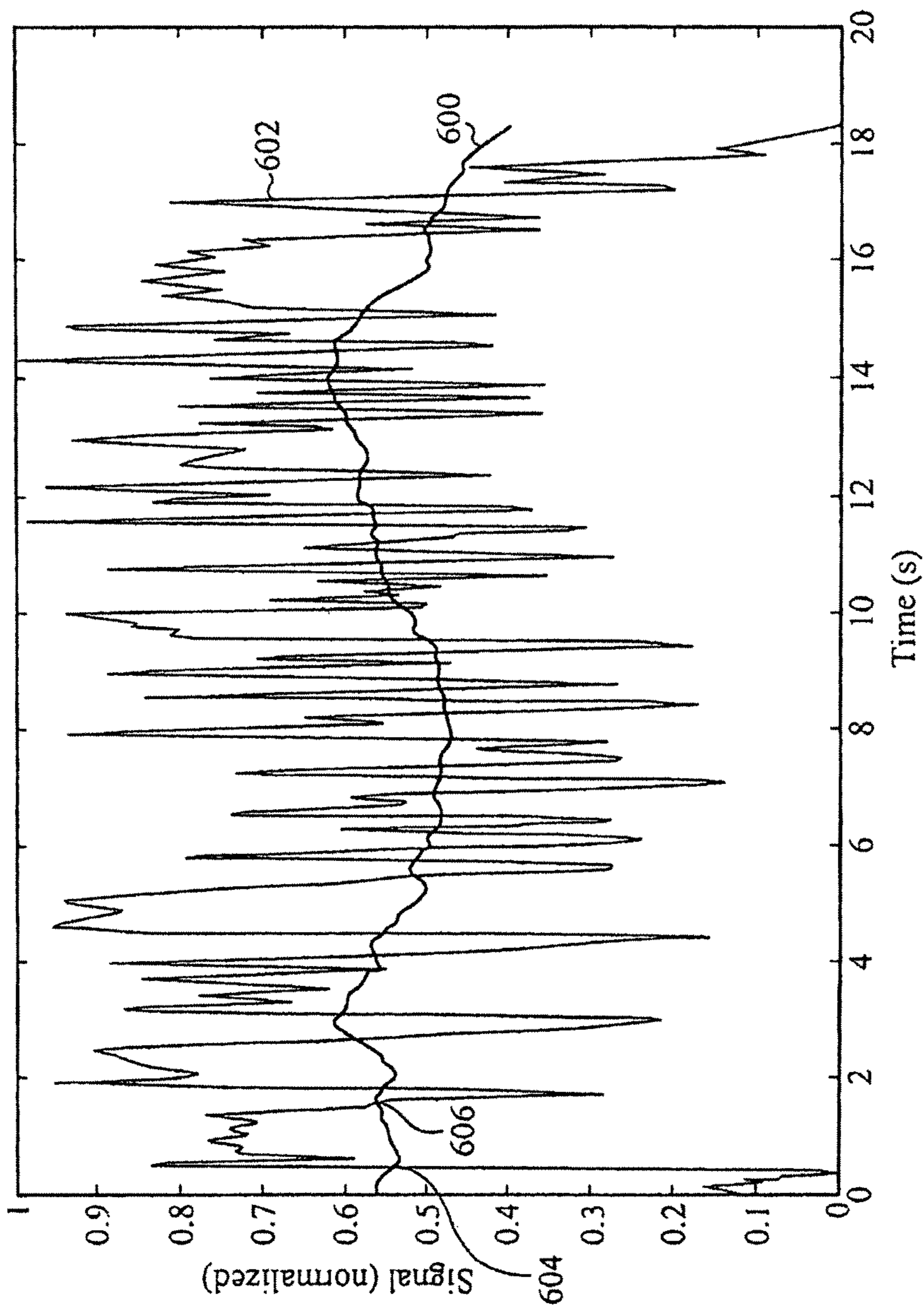

Fig. 6

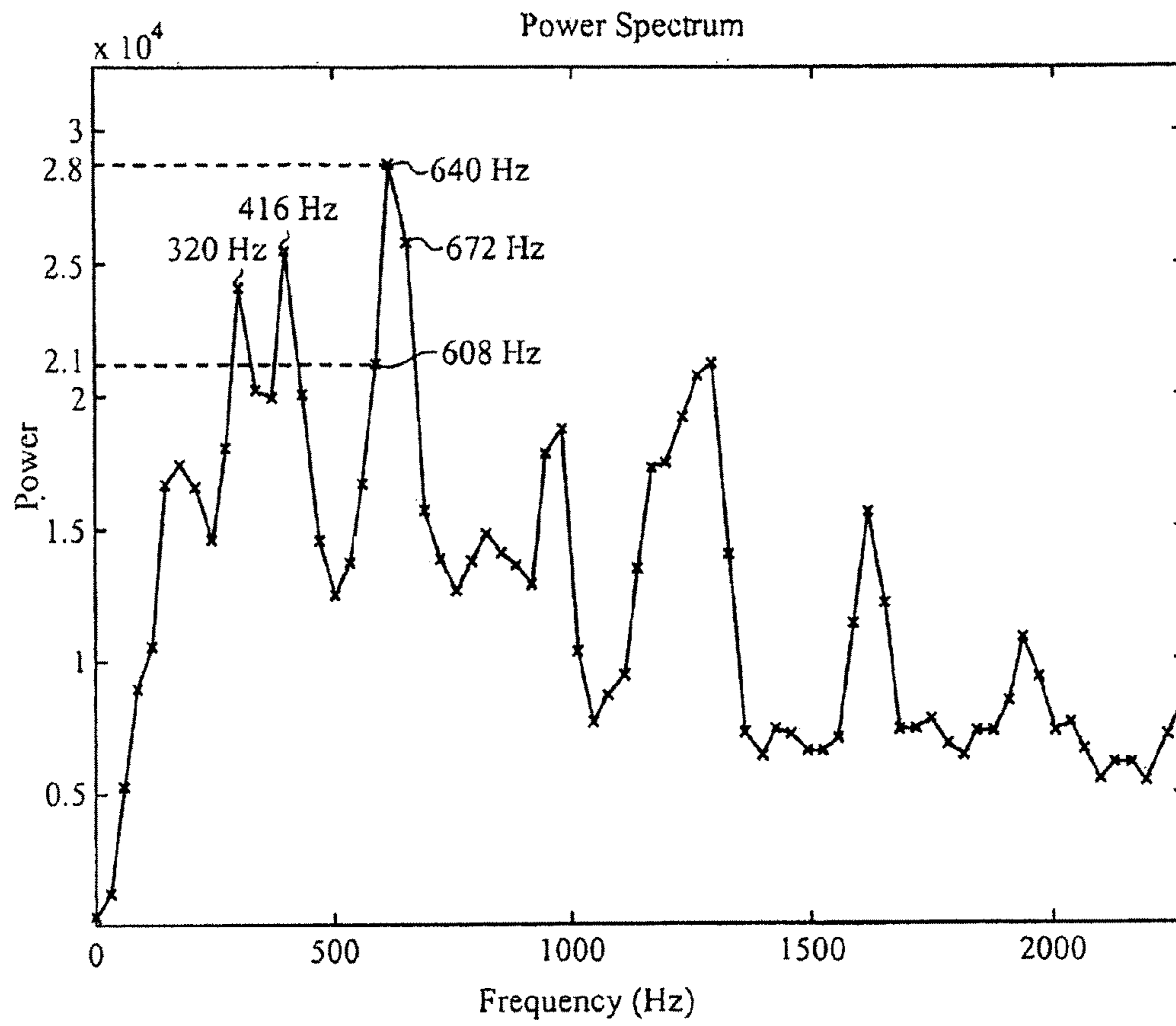

Fig. 7

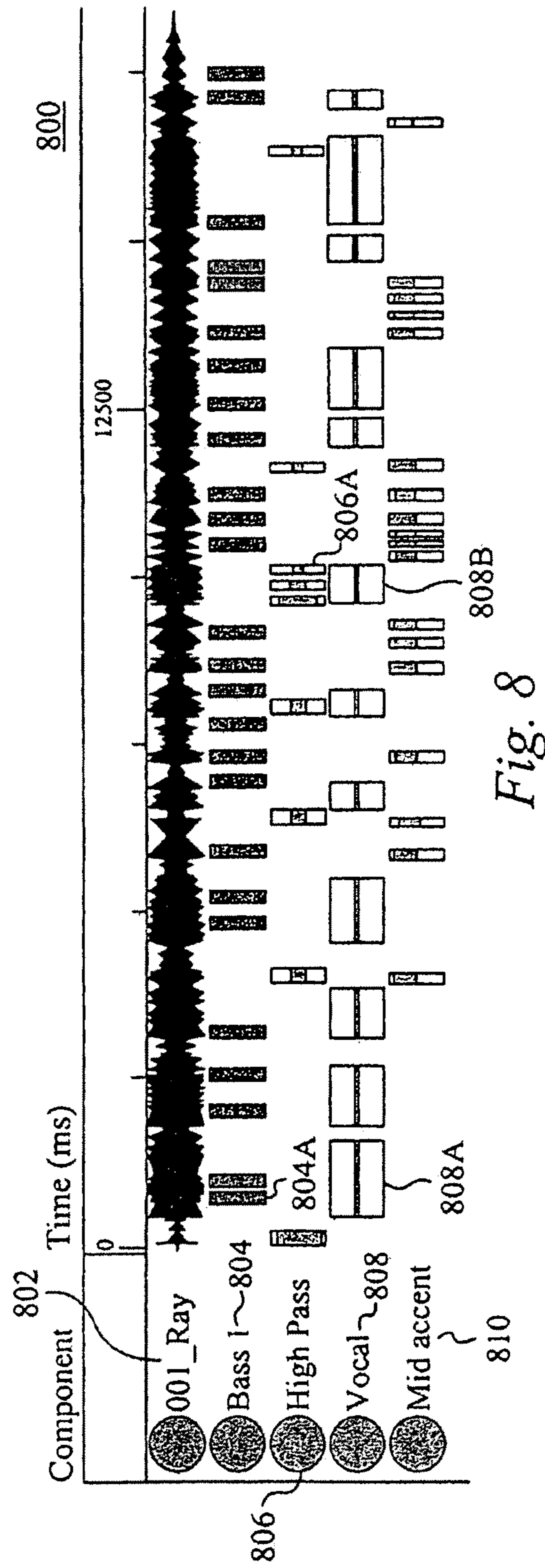

Fig. 8

900

908

906

902

900

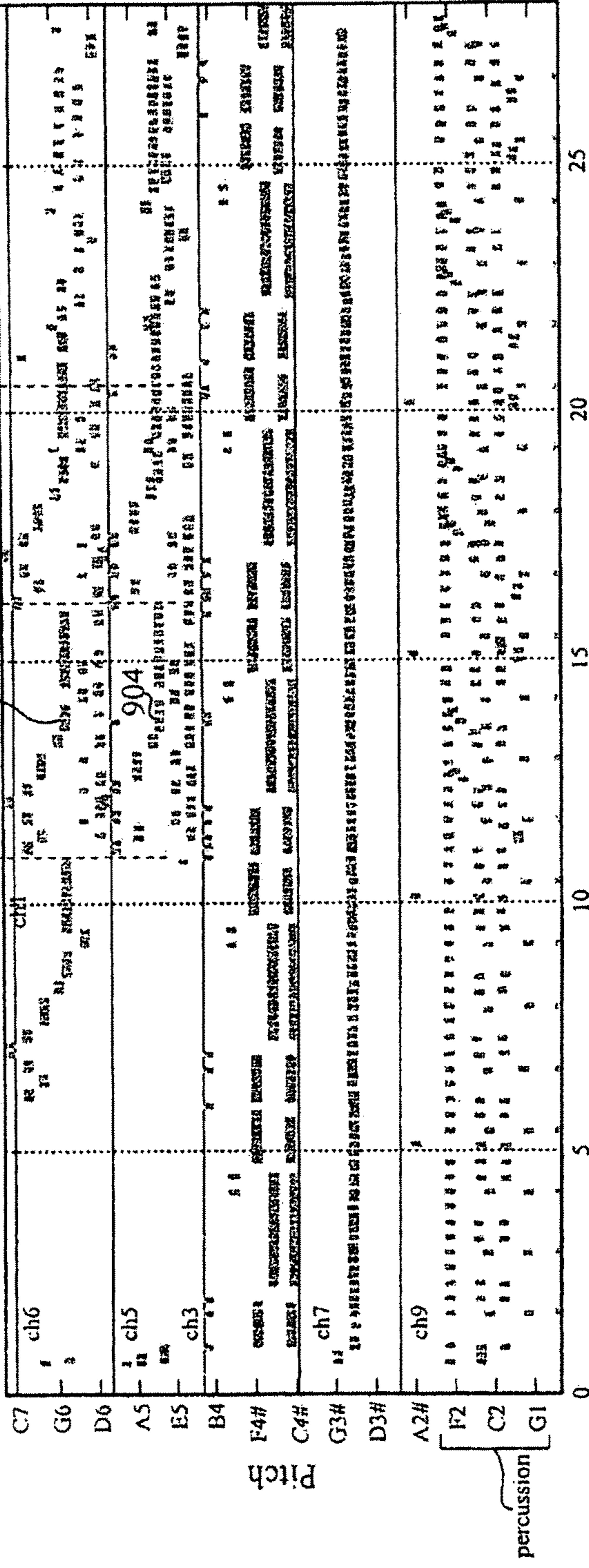

Time in seconds

Fig. 9

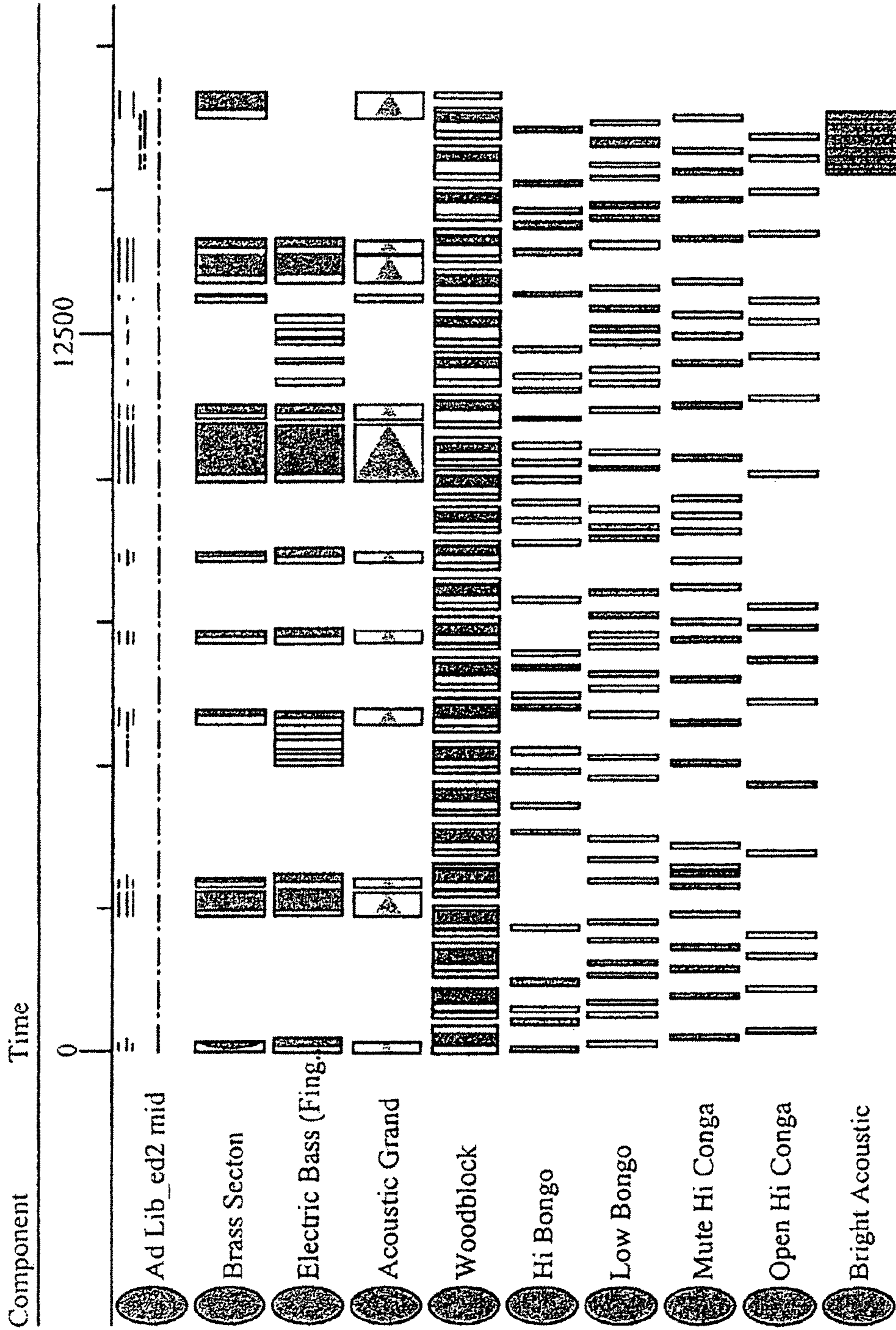

Fig. 10

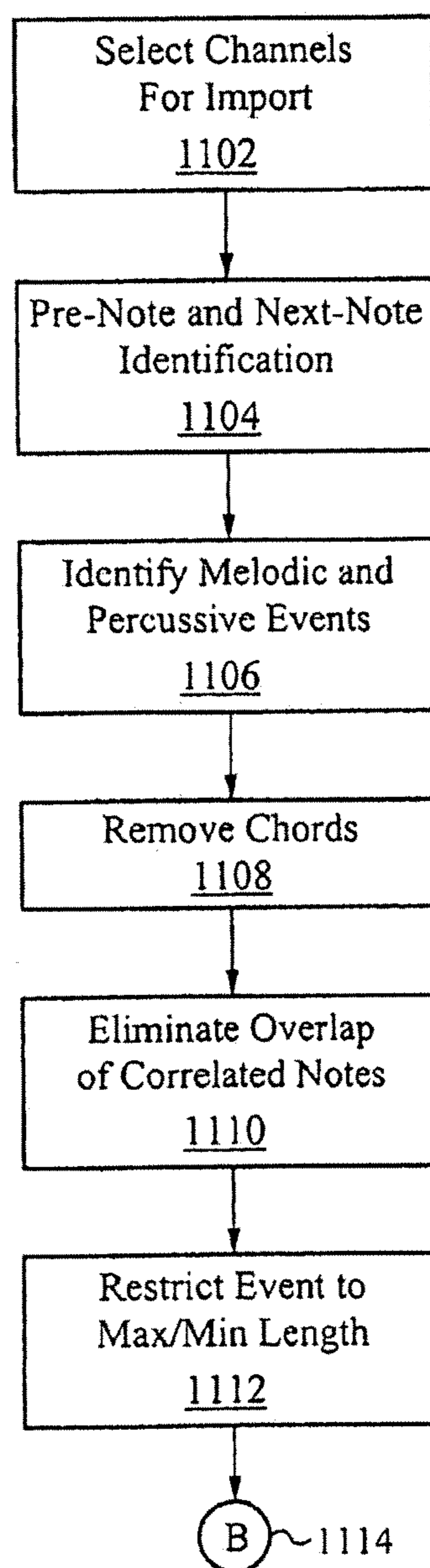

Fig. 11A

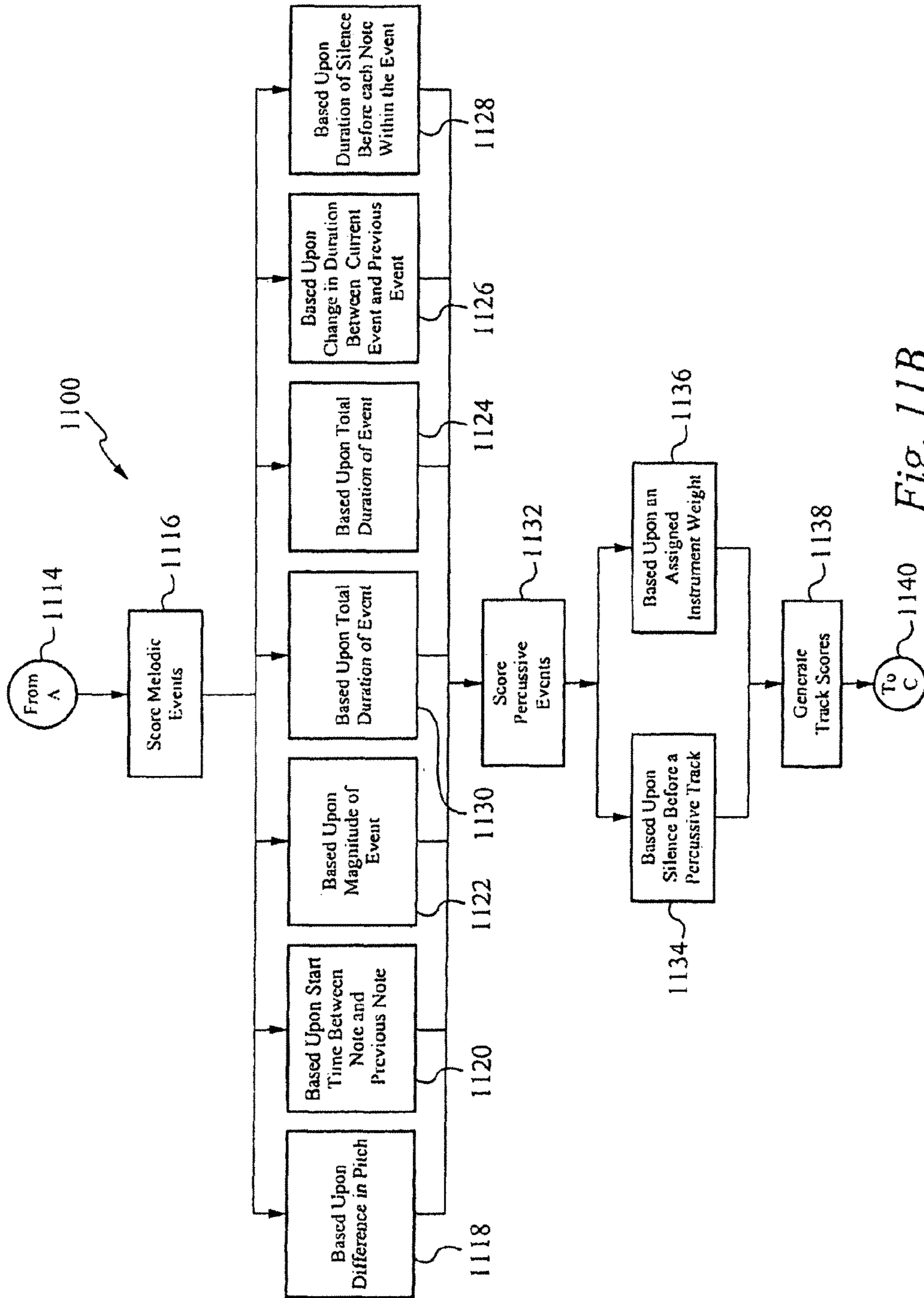

Fig. 11B

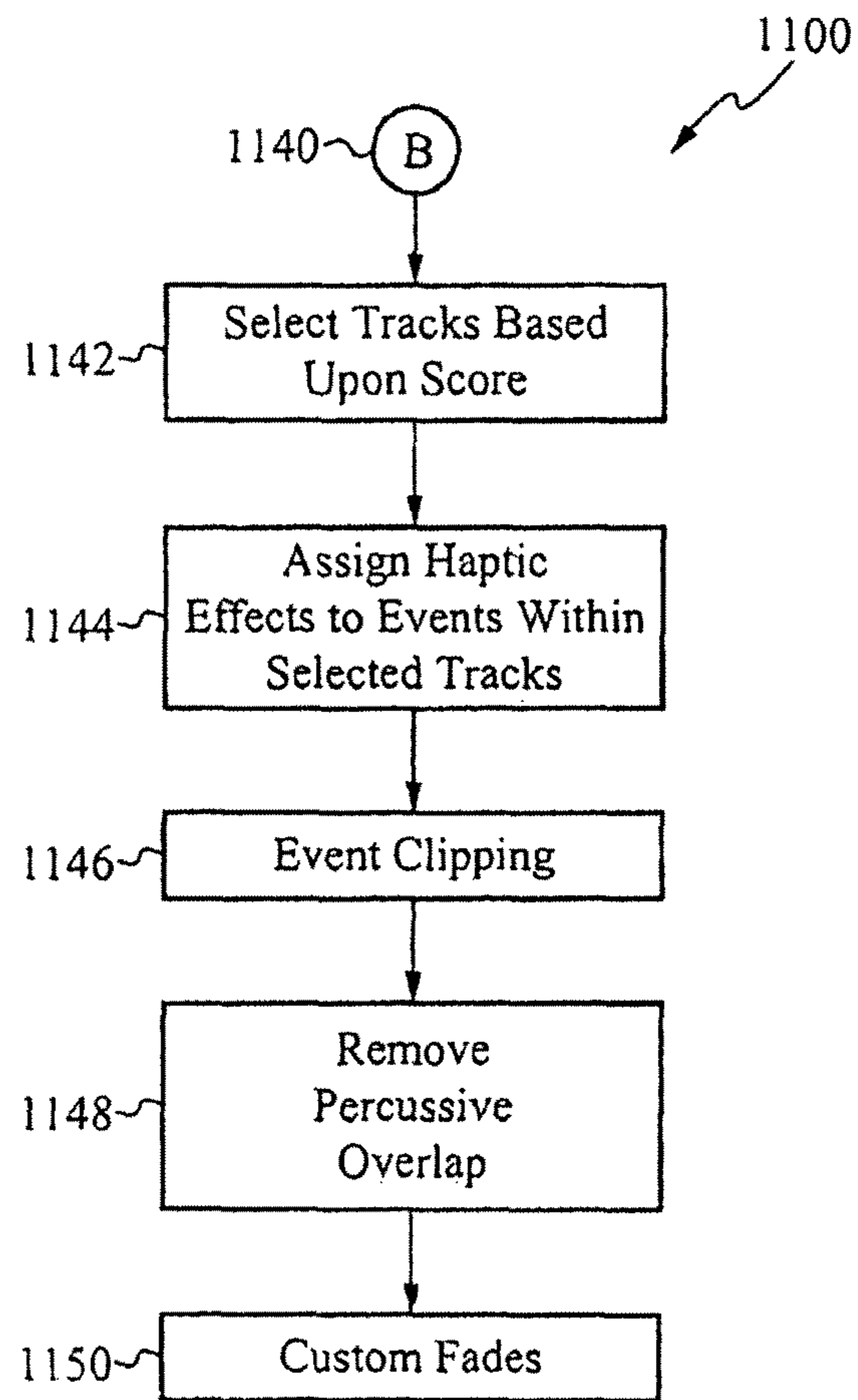

Fig. 11C

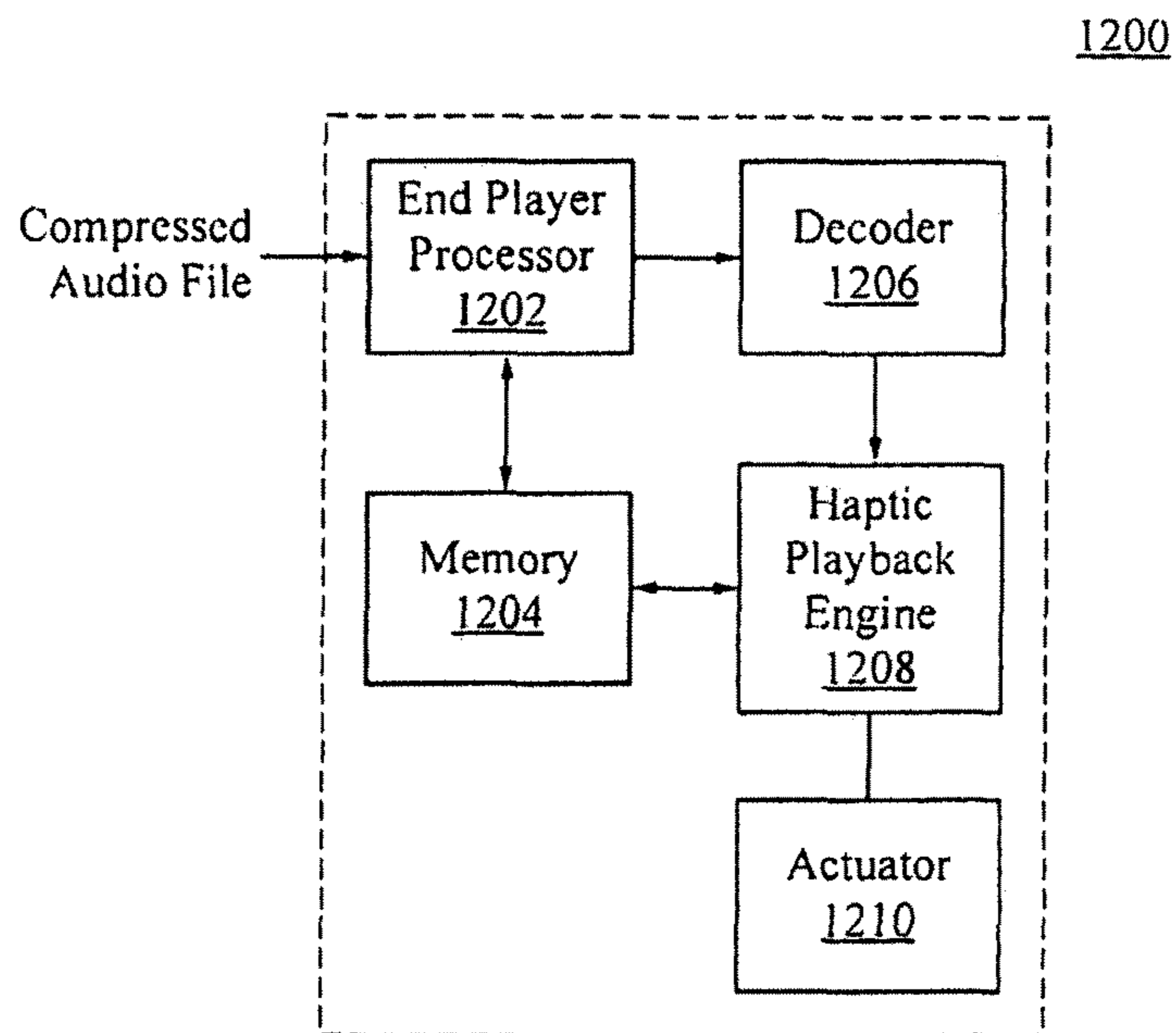

Fig. 12

1

SYSTEM AND METHOD FOR AUTOMATICALLY PRODUCING HAPTIC EVENTS FROM A DIGITAL AUDIO FILE

CROSS-REFERENCE TO RELATED APPLICATIONS

The present application is a continuation of U.S. patent application Ser. No. 12/140,133, filed Jun. 16, 2008 (incorporated by reference herein) which is a continuation-in-part of U.S. patent application Ser. No. 11/515,243, filed Aug. 31, 2006 (incorporated by reference herein) which claims the benefit of priority based on U.S. Provisional Patent Application Ser. No. 60/792,137, filed on Apr. 13, 2006 (incorporated by reference herein), in the name of inventors Stephen D. Rank and Christopher J. Ullrich, entitled "Music to Haptic Code Conversion," commonly owned herewith.

FIELD

The subject matter described herein relates generally to the field of haptics, and more particularly to generating a haptic effect control signal or haptic track corresponding to a digital audio or audio/visual file

BACKGROUND

Tactile vibrations are often desirable in a user interface device. Touch unifies the spatial senses; those you use to navigate your way through the world—sight, sound, and touch. Touch produces reflex-rate response in milliseconds (ms) and supplies a completeness that sight and sound together can't replace.

In a user interface device, it is useful to have tactile vibrations match sound such as when a music file is played on a cell phone. Audio for end-user devices may be encoded in two basic ways: in a structured representational format, such as a protocol which symbolically encodes the sounds to be played into a string of known symbols (e.g. Musical Instrument Digital Interface or "MIDI"); and as digital sampled audio, which is a set of periodic samples of the audio waveform.

Currently, sampled audio files can be converted through manual conversion. A human designer listens, analyzes, and judges the sampled audio file and selects features of the sampled audio from which to create haptic effects. However, human design intervention is a constrained resource.

What is needed is a fully-automated or semi-automated method of converting music files into haptic effects.

SUMMARY

In an embodiment, a method comprising processing a digital audio file having data characterizable into a plurality of frequency sub-band signals; identifying a plurality of audio events in at least one sub-band; and assigning a haptic effect to at least one of the events to produce a haptic event to be output by an actuator.

In an embodiment, an apparatus comprising: a circuit for processing a digital audio file having data characterizable into a plurality of frequency sub-band signals; a circuit for identifying a plurality of audio events in at least one sub-band; and a circuit for assigning a haptic effect to at least one of the events to produce a haptic event; and an actuator configured to output the haptic event.

In an embodiment, an apparatus for manipulating a digital audio signal comprising: means for separating the audio signal into a plurality of sub-band signals; means for segmenting

2

at least one of the sub-band signals into a plurality of events; and means for assigning a haptic effect to at least one of the events to produce a haptic event to be output by an actuator

In an embodiment, the system and method computes a spectral decomposition of the audio signal. In an embodiment, the system and method designates a minimum separation time between events. In an embodiment, the system and method designates a minimum actuator start-up time prior to a first haptic event. In an embodiment, the system and method designates a minimum duration of time for each haptic event in a plurality of haptic events. In an embodiment, the system and method designates a minimum separation time between events. In an embodiment, the system and method designates a minimum actuator start-up time prior to a first haptic event. In an embodiment, the events within the sub-band signal correspond to a user specified average number of haptic effects per second. In an embodiment, the events within the sub-band signal have an alias value below a maximum alias target value. In an embodiment, the system and method calculates an average over a designated period of time for a parameter of one or more sub-band signals.

In an embodiment, the system and method designates an event if a short term value of the parameter of the sub-band signal exceeds a multiple of the average for the parameter. In an embodiment, the system and method computes a power spectrum of the spectral decomposition of the audio signal; selects a frequency based at least in part on the power spectrum; and identifies an event based at least in part upon the selected frequency. In an embodiment, the system and method stores the haptic event on a server capable of being in communication with a client over a network, wherein the server delivers the haptic event to the client.

BRIEF DESCRIPTION OF THE DRAWINGS

The accompanying drawings, which are incorporated into and constitute a part of this specification, illustrate one or more embodiments of the present invention and, together with the detailed description, serve to explain the principles and implementations of the inventive subject matter.

FIG. 1 is a portion of a musical piece represented in a visually perceivable manner using a traditional sheet music style comprising a sequence of notes, chords and rests.

FIG. 2 is a time-amplitude graph of a portion of a sampled audio signal.

FIG. 3 is a process flow diagram illustrating a method for haptic effect mapping in accordance with an embodiment.

FIG. 4 is an overall architecture diagram of the system piece in accordance with an embodiment.

FIG. 5 is a filtered time-amplitude graph showing high-frequency and medium-frequency sub-band signals for the musical piece of FIG. 4 in accordance with an embodiment.

FIG. 6 is a normalized time-signal graph showing a representation of average power and instantaneous power used to segment the medium-frequency sub-band signal in accordance with an embodiment.

FIG. 7 is a frequency-power graph used to segment the low-frequency sub-band signal in accordance with an embodiment.

FIG. 8 is a time-symbol representation of a sequence of haptic effects for the FIG. 4 musical piece example in accordance with an embodiment.

FIG. 9 is a time-note representation of a series of MIDI events making up a musical piece in accordance with an embodiment.

FIG. 10 is an alternative time-instrument-note representation of a series of MIDI events making up a musical piece in accordance with an embodiment.

FIGS. 11A, 11B and 11C together constitute a process flow diagram illustrating a method for MIDI sequence processing to yield a corresponding sequence of haptic effects in accordance with an embodiment.

FIG. 12 illustrates a block diagram of an end device in accordance with an embodiment.

DETAILED DESCRIPTION

Embodiments of the subject matter are described herein in the context of a system for automatic audio to haptics conversion. Those of ordinary skill in the art will realize that the following detailed description of the present invention is illustrative only and is not intended to be in any way limiting. Other embodiments of the present invention will readily suggest themselves to such skilled persons having the benefit of this disclosure. Reference will now be made in detail to implementations of the present invention as illustrated in the accompanying drawings. The same reference indicators will be used throughout the drawings and the following detailed description to refer to the same or like parts.

In the interest of clarity, not all of the routine features of the implementations described herein are shown and described. It will, of course, be appreciated that in the development of any such actual implementation, numerous implementation-specific decisions must be made in order to achieve the developer's specific goals, such as compliance with application- and business-related constraints, and that these specific goals will vary from one implementation to another and from one developer to another. Moreover, it will be appreciated that such a development effort might be complex and time-consuming, but would nevertheless be a routine undertaking of engineering for those of ordinary skill in the art having the benefit of this disclosure.

In accordance with the subject matter described herein, the components, systems, devices, process steps, and/or data structures may be manufactured, operated and/or implemented using various types of operating systems, computing platforms, computer programs, and/or general purpose machines. In addition, those of ordinary skill in the art will recognize that devices of a less general purpose nature, such as hardwired devices, field programmable gate arrays (FPGAs), application specific integrated circuits (ASICs), or the like, may also be used without departing from the scope and spirit of the inventive concepts disclosed herein. Where a method comprising is implemented by a computer, device or a machine and the method may be stored as instructions readable by the machine, they may be stored on a tangible medium such as a computer memory device, including, but not limited to, ROM (Read Only Memory), PROM (Programmable Read Only Memory), EEPROM (Electrically Erasable Programmable Read Only Memory, FLASH Memory, Jump Drive, and the like), magnetic storage medium (e.g., tape, magnetic disk drive, and the like), optical storage medium (e.g., CD-ROM, DVD-ROM, paper card and paper tape, and the like) and other known types of program memory. In addition it should be recognized that the method could be executed by a human operator using a selection of software tools without requiring human or creative judgment.

In an embodiment, the audio file contains sampled digital or digitized analog audio which the system processes, identifies and calculates frequency sub-band signals as well as coefficients associated therewith which are then used to output appropriate haptic events. In an embodiment, the system

and method described herein is directed to receiving digital files and automatically outputting haptic events which are synchronized with the frequency sub-band coefficients already within the digital audio file. This less computationally intensive approach by the system allows the system to automatically output haptic events in real time and/or in an off-line mode. In another embodiment, the received files are structured representation files (e.g. MIDI files). It should be noted that although MIDI files are described herein in terms of structured representation files, any other protocol may be used by the system, whereby the protocol utilizes structured representation files which may be output audio, video or other signals. The converted haptic events are processed and output by an end-device in which the user experiences a pleasing haptic experience which corresponds with the audio output by the end-device and/or another device. The end-device includes, but is not limited to, audio players, mobile phones, smart phones, video players, PDAs, computers, televisions, video game consoles, computer peripherals (e.g. mouse, joystick, roller ball, keyboard), steering wheels, furniture, sliders, knobs, headphones, touchscreens, portable or non-portable radios, one-way/two-way pagers and other appropriate user manipulatable electronic devices.

It should also be noted that although the system and method is described herein to be output by an end-device, a plurality of end-devices may simultaneously or at varying times output the same haptic events and/or different portions of the same haptic events in accordance with an embodiment. It should be noted that the end device may include one or more actuators therein. In an embodiment of multiple actuators in the end device, haptic events to be output by the multiple actuators may be done simultaneously, selectively, alternately, and/or individually for each haptic event.

FIG. 4 illustrates an overall architecture embodying the system in accordance with an embodiment. As shown in FIG. 4, a variety of sources may provide the input signal 99 to the system 300. For example, the digital sampled audio signal or structured representation signal may be received from a server 402, audio signal source (CD, DVD, DAT, etc.), host computer 406, mobile device 408 and/or commercial kiosk 410. The input signal is sent over a wired or wireless private or public network 98 to a receiving module 412 of the system 300. The signal is then processed by processor 414 as discussed in more detail below. Once processed, the system 300 outputs the processed information by hard-wire or wirelessly through port 416 to one or more end devices 420. The end device 420, upon receiving the output file is then capable of outputting the haptic events using one or more actuators 422 along with an optional audio speaker 424. It should be noted that the architecture described in FIG. 4 is an embodiment, whereby additionally and/or alternative components may be utilized without departing from the scope of the subject matter described herein.

Turning now to the figures, FIG. 1 illustrates a portion 100 of a musical piece represented in a visually perceivable manner using a traditional sheet music style comprising a sequence of notes, chords and rests. The musical piece may be played and recorded, for example, in a digital sampled form or in a structured representation form. Each musical note represents a frequency of mechanical vibration. The types of notes (i.e. A, A#, B, C, C#; D, D#, E, F, F#, G, G#) are different from one another in terms of pitch. Whole notes, half notes, quarter notes, eighth notes, sixteenth notes, and the like, represent the duration of play for each note or frequency. Likewise, whole rests, half rests, quarter rests, eighth rests, sixteenth rests, and the like, represent durations of time in which no note is played. The sequence of the notes and their

duration determine the representation of which frequencies will be played at which times.

An embodiment of the present invention is directed to automatically mapping haptic events to a digital sampled audio file. Sampled audio sources (and files), which have, but are not limited to, WAV, MP3, MP4, AAC, ASX, WMA formats, all provide essentially the same type of information, such as a sample rate and a set (often left and right channels) of time ordered samples. Certain compressed files such as MP3 and AAC format contain information therein relating to sub-band frequencies as well as magnitudes and coefficients of audio events in those sub-band frequencies. However, unlike structured representation files, no explicit information about instruments, pitch, tempo or other musical context is available in non-structured representation files—only the fully rendered sounds are available. A time-amplitude graph of an example sampled audio signal is shown in FIG. 2.

Additionally, or alternatively, the system is capable of automatically mapping haptic events from a structured representational signal (e.g. MIDI). In particular, given a particular structured representation of an audio file, the system is able automatically map the haptic events by analyzing the data inherently provided by the structured representational signal. However, automatically mapping either type of file, the input signal is carefully processed and analysis is simplified due to the performance limitations of the actuators in the end-device to provide the pleasing distinct haptic sequences from the audio signals in the file.

Current haptic technology is capable of playing up to about four simultaneous haptic events and operating with about a 1 ms control loop. This is due to the limitations of existing actuators. Given the limitations of existing Eccentric Rotating Mass (ERM) motor technology, playing simultaneous haptic effects can result in unexpected actuator behavior. Also ERM motors have relatively low mechanical bandwidths which limit the haptic event frequency to a maximum of about 4 haptic events per second. ERM motors also have a startup delay of about 50-80 ms before peak acceleration is achieved and this startup delay must be taken into account in creating haptic control signals to drive such ERM motors. Although ERM motors are described in the context of the described subject matter herein, it is contemplated that other types of motors or actuators may be used depending on the type of end-device, haptic effect resolution, digital quality of the to-be-converted audio, and application of use. For example only, the actuator may be a linear resonant actuator (LRA) which has resolution capabilities superior to ERM motors. Other types of actuators are contemplated including, but not limited to linear current control motors, stepper motors, magnetic actuators, pneumatic/hydraulic active actuators, torquers (motor with limited angular range), and voice coil actuators.

To provide a pleasing haptic experience to the user in contact with the haptically enabled end-device, the system should not generate haptic events that are too numerous within a period of time. In addition, the haptic events should be spaced far enough apart not to produce one constant vibration or “blur”, but nonetheless be consistent with the sound effects, musical tempo and/or melodies. Exceptional events, such as a change of key, melodic transitions, and the like, should often be highlighted by the haptic event. The musical rhythm should often be accented by identifying the tempo of the audio program signal and the phase offset of that tempo relative to the beginning of the audio program signal. Audio events which have a substantial amount of silence beforehand may also be likely haptic events due to their accent in the music (e.g. cymbals, car crashing as a sound effect).

FIG. 3 is a process block diagram illustrating a system and method for haptic effect mapping of a received digitized sampled audio signal in accordance with an embodiment. In general, according to an embodiment, the received sampled audio input is received and automatically “converted” or “mapped” by the system to form a haptic control signal or haptic event which controls the playback of haptic effects in the end device to be in synchrony with the playback of identified audio events in the signal. The blocks in FIG. 3 are designated as generic components which may be analog or digital hardware, including but not limited to, hardwired circuits, Integrated Circuits and ASICs. Additionally or alternatively, the blocks in FIG. 3 are software code components such as routines, subroutines, code, threads and the like embodied in or utilized by processors and memories.

In accordance with the embodiment in FIG. 3, the received sampled audio signal is loaded into memory of a computational device in block 310. The computational device may be a conventional personal computer, a processing module, server, client, the end-device itself defined above, or any other electronic device having sufficient processing capabilities. The sampled audio signal may be taken from a compact disc (CD), mini-disc, DVD, DAT, hard-drive or other media. As stated, the audio signal may be in a compressed digital audio format (e.g. Mp3, AAC, etc). In an embodiment, the audio signal may be downloaded directly (wired or wirelessly) from a commercial or non-commercial website which is then converted and playable by the end-device. In another embodiment, audio tracks are converted remotely and then stored on a server, whereby the converted haptic tracks are able to be downloaded directly from the server to one or more end-devices to be played. In an embodiment, the received file is processed by the system off-line, whereby the system processes a portion or the entire file after it has been received. In an embodiment, the received file is processed by the system in a real time manner, whereby the system processes and outputs the data as the file is being received, as discussed in more detail below. The received file may be input into a file reader/player which included in a commercial computer software program such as Microsoft Windows Media Player®, RealPlayer®, iTunes®, MusicMatch Jukebox®, or other proprietary program on a server and/or end-device. Alternatively, any codec (encoder-decoder) that generates PCM type output may be used in conjunction with the system.

In an embodiment, the system receives the sampled audio as a single (monaural) input signal. In an embodiment, the system receives the sampled audio as stereo or multi-channel inputs which may be converted or mapped by pre-mixing or sub-selecting, for example. Additionally, multiple haptic tracks could be processed simultaneously or at different times, if desired.

As will be discussed, the received signal may be computationally analyzed by the system, whereby the system effectively calculates frequency sub-band coefficients in analyzing and identifying the audio events in the sub-bands. After the input signal is loaded into an optional memory of the system in an embodiment. The system retrieves the signal from the memory and analyzes the input signal in terms of its energy content per time and frequency in block 312. In an embodiment, the system uses a windowed Fast Fourier Transform (FFT) algorithm to produce energy distribution data of the audio signal in block 312. In an embodiment, any another appropriate procedure or algorithm, including but not limited to wavelet transform, is utilized to produce energy distribution information of the signal. The spectral decomposition

analysis may also produce phase information encoded as complex coefficients which may be utilized by the system in processing the signal.

In an embodiment, the system utilizes a compensation factor to the spectral decomposition calculations to account for the Human Ear transfer function and perceptual factors prior to segmentation of the frequency sub-bands. For instance, the human ear is more sensitive to sounds at 3-4 kHz as opposed to sounds at 60 Hz. In an example, the system will attenuate frequency content around 60 Hz by approximately 40 dB whereas content at frequencies between 3 kHz and 4 kHz is not attenuated. Therefore, even though there may be significantly more energy in a 60 Hz beat, the user will likely perceive a beat in a higher frequency band as more prominent due to the attenuation.

Similarly, the audio transfer function of the speakers for the target haptic device can be taken into consideration and applied to the spectral decomposition prior to segmentation. For example, the frequency response on most cell phone speakers is such that frequencies below 200 Hz are not transmitted. Therefore, emphasizing a beat under 200 Hz might yield unexpected haptic effects when accompanying the audio signal rendered by such speakers. Ignoring these frequency bands in the spectral decomposition in processing may give more consistent results.

In an embodiment, the system utilizes the absolute value of the complex coefficients from the spectral decomposition analysis to map the energy distribution of the audio signal in terms of frequency to allow the designation of sub-band signals and crossover frequencies of the audio signal. This is designated in block 314 in FIG. 3.

As shown in FIG. 3, the system and method determines a number of sub-band frequencies from the energy distribution of the input audio signal at block 314. As stated above, the system may perform this analysis using software, analog or digital hardware and/or firmware. In an embodiment, the system analyzes the energy distribution of the signal and designates the energy into three sub-band categories based on frequencies. In an embodiment, the sub-band categories are high frequency sub-bands, medium frequency sub-bands, and low frequency sub-bands. FIG. 5 illustrates an example filtered time-frequency graph showing the high-frequency sub-band signal 500 and the medium-frequency sub-band signal 502 of the input audio signal. In an embodiment, the system and method designates the energy distribution of the input audio signal into to more or less than three sub-band categories.

In an embodiment, the low-frequency sub-band is designated by the system to be within a range of low frequency values, whereas the high-frequency sub-band is designated to be within a range of high frequency values. The system designates a medium-frequency sub-band to be between the highest frequency in the low sub-band and the lowest frequency in the high sub-band. It should be noted that each of the frequency sub-band ranges are not limited to those discussed, and each sub-band can be designated to have any upper and lower frequency limits based on the desire of the designer. In an embodiment, the low, medium and high frequency ranges are determined by the system based on a global average of a power spectrum of the entire signal or segmented portions of the entire signal. It is contemplated that the low, medium and high frequency ranges may be determined by the system utilizing any other appropriate methods.

In particular, the system and method analyzes the input audio signal in terms of sub-band crossover frequencies. In an embodiment, the system calculates one or more sub-band crossover frequencies f_m between the low-frequency sub-

band and the medium-frequency sub-band. Additionally, the system and method calculates one or more sub-band crossover frequencies f_h between the medium-frequency sub-band and the high-frequency sub-band. In an example, f_m is designated to be in a range of approximately 300 Hz to approximately 1000 Hz. In an example, f_h is designated in a range of approximately 3500 Hz to approximately 5000 Hz. It should be noted that these ranges are only examples and that other frequency ranges are contemplated within the scope of the system and method.

In an embodiment, the f_m and the f_h frequencies are computed as the mean values of the 15th and 85th percentile spectral rolloff in which the spectral rolloff is the frequency below which a specified percentage of the total energy of the audio input signal can be found. These specified percentages may be computed from the energy distribution of the signal calculated in block 312. It should be noted that other spectral roll off percentiles are contemplated and are not necessarily limited to the 15th and 85th percentile. In an embodiment, the system and method normalizes the energy for designated frequencies in each time window and calculates the cumulative value that corresponds to the specified percentile. It should be noted that this is one method of calculating the cross-over frequencies and other methods of calculating the cross-over frequencies are contemplated. For example, in an embodiment, the sub-band signal crossover frequencies may be computed by calculating the FFT of the entire signal and calculating the roll-off values. Three sub-band signals may then be constructed from the energy distribution (e.g. spectrogram) of the input audio signal by summing the energy values in each sub-band. This procedure may also serve to down-sample the input signal since the 44 KHz time information (the original audio sample rate) may be converted to 128 Hz time data during the spectral decomposition computation.

In an embodiment, the high- medium- and low-frequency sub-band signals are each segmented and are processed by the system. As shown in FIG. 3, the medium frequency sub-band signal is sent to a medium band optimizer, designated by block 316. The medium band optimizer 316 generates a track of discrete events corresponding to a desired number of effects per second (EPS). In an embodiment, the targeted EPS are defined by the user, although the EPS may be defined based on certain factors, including, but not limited to, resolution of the actuator, type of music, type of end-device, and processing capabilities of the system or the user's desire.

The system enforces a minimum separation between haptic events to permit the actuator in the end-device an appropriate time to start up and wind down for each haptic effect that it outputs. This minimum separation allows the actuator in the end-device to produce discrete multiple haptic events and prevents two or more haptic events from overlapping or producing a "blurred" feeling of portions of multiple haptic effects overlapping each other. In an embodiment, the amount of time limited between the haptic events is 50 ms, and the specified duration is between 100-250 ms, depending on the sub-band. It should be noted that the system is not limited to these values and other values are contemplated.

The medium band optimizer 316 attempts to capture the melody of vocal events by generating the track of discrete haptic events to correspond to the vocal melody in the audio input signal. The system thus utilizes the clipping parameter to identify the events with the highest amount of energy within the target range of the desired EPS.

Upon the clipped input signal being output from the medium band optimizer 316, the signal is input into a local segmenter 318, as shown in FIG. 3. In general, the local

segmenter 318 utilizes an algorithm which compares a long time-average of the clipped input signal with a short-time value of the clipped input signal to segment the medium frequency sub-band signal into a series of start and end times for each event. As shown by the arrow in FIG. 3, the local segmenter 318 then provides this information back to the optimizer 316, whereby the optimizer 316 applies a one-dimensional line search to monotonically adjust one or more clipping parameters until the segmentation of discrete events is in the target range of the desired EPS. In an embodiment, this process is repeated until the desired number of EPS is reached for the signal. In an embodiment, the segmentation process is repeated for a pre-set number of iterations. The particulars of the segmentation process will now be discussed.

FIG. 6 illustrates a time-signal graph showing a representation of average power and short-time power used to segment the medium frequency sub-band signal into the discrete haptic events in accordance with an embodiment. The graph of FIG. 6 illustrates the time-average 600 of the medium frequency sub-band signal as well as the short-time signal values 602 within a 20 second window. It should be noted that other time duration windows may be utilized by the system.

The short-time signal value, in an embodiment, may be obtained by low-pass filtering the input audio signal through a 5 Hz Butterworth filter. It should be noted that the input signal is filtered utilizing any other device or method in either the analog or digital domains. In an embodiment, the system creates a new event at a certain time where the short-time average value signal exceeds a specified threshold for that point in time. In terms of the graph of FIG. 6, the event begins and ends at the points where the short time average values cross the long time average in a desired direction (e.g. upwardly or downwardly). For example, in FIG. 6, the local segmenter 318 determines where an event begins (point 604) by identifying where the short time average 602 crosses the long term average line 600 in an upward direction. The local segmenter 318 may also determine where the event ends by identifying where the short time average 602 crosses the long term average line 600 in a downward direction (point 606). It should be noted that the above is only an example of a segmentation process and it is apparent that other segmentation processes and algorithms may be used by the system.

For low and high frequencies, it is common for there to be more events that qualify as haptic events than the actuator in the end-device can effectively produce per second. The optimization process discussed above in regards to medium frequency sub-bands are not preferred for higher and lower frequency sub-bands due to the large number of closely spaced frequency peaks which are usually inherent in high and low frequency sub-bands (FIG. 5). These large number of closely spaced frequency peaks may cause the actuator to produce aliased results inconsistent with the tempo of the input audio signal.

To address this issue, the system utilizes a different optimization and segmentation approach for signals in the high and low frequency sub-bands than that of the medium frequency sub-bands. FIG. 3 illustrates that the high and low frequency sub-bands are processed differently by the system. In regards to the high frequency sub-band, aliasing is a concern which the system takes into account when processing the signal. Thus, haptic events generated without consideration for this aliasing may follow a beat or rhythm that is inconsistent with the music.

In general, as shown in FIG. 3, the system includes a high frequency optimizer 320 block which performs a one-dimensional (1-D) line search to adjust one or more clipping param-

eters on the high frequency signals. The optimizer block 320 uses a measure of the amount of aliasing in the output signal and adjusts the clipping value which is then provided to the segmenter block 322. The high sub-band segmenter 322 determines the start and/or end times of each haptic event and provides the result back to the optimizer block 320 as shown by the arrow. The optimizer 320 then adjusts the clipping value in response until the targeted alias level is reached or a certain number of pre-defined steps have occurred.

Aliasing is measured by examining the distribution of differences between the start times of generated haptic events. If this distribution has a very large peak at the same delta as the minimum effect separation dictated by the actuator, the segmentation result is considered to have high aliasing. A reasonable target alias value might be 30%, which means that 30% of the effects have start times that differ by exactly the minimum separation value

The algorithm used in the Segment block 322 may be the same as that used by the medium sub-band 320 in an embodiment. In an embodiment, the algorithm used to process high frequency sub-band signals by block 322 is similar to the algorithm performed by the block 318 for medium-frequency sub-band signals, but with several differences. In an embodiment, the long time average is 50 ms for high frequency signals.

In an embodiment, the input signal is pre-processed to increase the signal to noise ratio (S/N). The S/N may be computed to be the ratio of the mean of the clipped signal to the maximum value of the signal, whereby the processed signal is computed by subtracting the scaled 1.5 second moving average from the input signal and setting negative values to zero. It should be noted that this is only an example, and the system is able to utilize another method to improve the signal to noise ratio in the signal.

In an embodiment, the haptic effects which are measured to be longer than 250 ms are clipped to a maximum of 250 ms for high frequency signals. In an embodiment, new segments are produced only if the clipped signal is greater than the highest peak in the most recent 50 ms window. It should be noted that the above are examples and are not limited to those factors described above. It should also be noted that one or more of the above factors may be utilized in performing the algorithm. The result of the high-frequency sub-band segmentation is typically a set of short haptic events that roughly correspond to the tempo of the input audio signal.

Referring back to FIG. 3, in an embodiment, the low frequency sub-band signals are processed differently than the medium frequency sub-band signals. The low-frequency portion of the input audio signal typically corresponds to the rhythm of the music and is also typically dominated by various types of percussion instruments and/or very low frequency vocals (e.g. bass vocals). As with the high frequencies, the system and method processes the low frequency sub-band signals to generate haptic events that are consistent with the rhythm and do produce excessive aliasing artifacts. It is common that the drum beats in the music are within a certain frequency range within the low frequency sub-band spectrum. Thus, in an embodiment, the system considers a narrow range of frequencies in the low-frequency sub-band to identify the beats.

In an embodiment, the system identifies this specific range of frequencies by first performing a spectral decomposition analysis (block 324) of the low-frequency sub-band signal of the original input signal using a much longer time frame window as compared to that in block 312. In an embodiment, the time frame window is $\frac{1}{32}$ second or 31 ms, although other durations are contemplated and not limited to 31 ms. The time

frame window provides significantly more resolution in the low-frequency range than the spectral decomposition computed at block 312 to evaluate the spectral rolloff of the signal. Once the system and method calculates the higher resolution energy distribution (block 324), the system calculates a power spectrum of the signal. This is performed by block 326, in which the system sums the energy distribution from the spectral decomposition over the designated time window. It should be noted that although the input signal is shown to undergo two different spectral decomposition analyses (blocks 312 and 324 in FIG. 3), the spectral decomposition of the low frequency sub-band signal may alternatively be done in block 312, whereby the results are utilized by block 326 in computing the power spectrum of the low frequency sub-band signal.

The system and method utilizes the power spectrum calculations (block 326) on the low frequency sub-band signal to sort the frequencies based on power level (block 328). It is common that several frequencies may correspond to the same peak in the power spectrum, whereby the redundant frequencies would be eliminated to allow more efficient sorting of the frequency peaks.

FIG. 7 illustrates a frequency-power graph (i.e. power spectrum) used to segment the low-frequency sub-band signal in accordance with an embodiment. The power spectrum represents the amount of energy present in the input signal in a set number of frequency bins. This information is used by the system to sort the frequency into bins of total power. For example, a bin of total power between 2.1 and 2.8 ($\times 10^4$) has the frequency peaks of 640 Hz, 672 Hz, 416 Hz, 320 Hz and 608 Hz, ranked in descending total power

To eliminate these redundant frequencies as well as to eliminate other peaks that may carry the exact same temporal distribution of energy or power, such as the same beat, a cross-correlation matrix between the temporal signals associated with each frequency bin is computed by the system, which is discussed in more detail below. In an embodiment, the correlation matrix will have an approximate high value at location (i,j) if the time signal at frequency bin f_i , and at f_j are positively correlated. In accordance with an embodiment, all the frequency bins are clipped that have a correlation coefficient higher than 0.5 with a bin that has a higher associated power. In other words, the system will retain the highest energy signal and not use the lower energy signals that are above the clipped correlation coefficient. It should be noted that the correlation coefficient is not limited to 0.5 and values other than 0.5 are contemplated. For those remaining frequencies, the algorithm utilized in block 324 uses the optimizer and segmenter (blocks 330, 332) with a maximum alias target of 15%, although other target percentages are contemplated.

In an embodiment, the system computes correlation coefficients between all successive frequency bins in the low frequency band. Audio segments corresponding to periodic snare drum beats, hand claps, etc. are usually high bandwidth events and are most easily identified by searching for the maximum correlation coefficients. The frequency band with the highest correlation coefficient to the next frequency is selected by the system for further processing in the low-pass detection algorithm. The correlation coefficients of two random variables x and y is given by:

$$\text{cor}(x, y) = E(x, y) - \frac{E(x)E(y)}{\sqrt{\sigma_x^2 \sigma_y^2}} \quad (1)$$

After the high-, medium- and low-frequency signals have been clipped and segmented, as described above, the system and method will generate a list of candidate haptic events for each of the sub-band signals. In particular, as shown in FIG. 3, the segmented high frequency sub-band signals are passed from the high frequency Segment block 322 to the priority clip block 334. In addition, the segmented medium frequency sub-band signals are passed from the block 318 to the priority clip summation block 334. Further, the segmented low frequency sub-band signals are passed from block 332 to the priority clip block 334.

It is possible for the system and method to simply output the haptic events directly without passing them through the priority clip block 334, however doing so would possibly yield muddled or blurred haptic sensations by the actuator in the end-device. This would be due to several haptic events overlapping in time. To overcome this, the system utilizes the priority clip block 334 to prioritize the candidate haptic events from each of the sub-band signals.

In particular, the priority clip block 334 may prevent more than one haptic event, from same or different frequency sub-bands, to be output by the actuator if they fall within a specified time period of one another. This also prevents overlapping sharp and strong events from canceling one another out. For instance, a sharp event (see below), such as a braking pulse, may terminate a strong event prematurely if both are to be output by the actuator at the same or substantially the same time.

In accordance with an embodiment, any priority of low-, medium- and high-frequency haptic events may be output by the priority clip block 334 regardless of their overlap. In an embodiment, a sub-band of frequencies could be assigned priority when two haptic events from different sub-bands are detected to overlap one another. This priority could be assigned based on the particular genre of music; the tempo of the song; the resolution of the actuator; and/or the amount of information in the input audio signal (e.g. lossy vs. lossless).

As shown in FIG. 3, the priority clip block 334 outputs the prioritized haptic events to the effect mapping block 336. In an embodiment, the effect mapping block receives the prioritized haptic events and assigns haptic effects to these discrete events. In an embodiment, the system utilizes two basic haptic effect types: periodic and magnitude-dependent. Periodic effects allow the period or speed of vibration to be explicitly controlled independent of magnitude. Periodic effects accurately produce vibration frequencies up to about 30 Hz, depending on the device. Magnitude-dependent effects vibrate at a magnitude- and device-dependent rate.

These two effect types are further characterized with three actuation styles or effects: strong, smooth and sharp. Each style has a different control mechanism, resulting in a slightly different sensation to the user. Strong effects are the effects which feel strongest to the user. Smooth effects have the characteristics wherein the strength of the effect is diminished to achieve higher frequencies for periodic effects. For the magnitude-dependent effects, the effect strength does not diminish. Sharp effects achieve the highest frequencies for periodic effects without diminishing strength, although strength diminishes significantly for magnitude-dependent effects.

13

Each effect includes parameters which are adjustable or able to be set by the system or by a user. Such parameters for periodic haptic effects include, but are not limited to, magnitude, period/frequency, duration, attack time, attack level, fade time, fade level and envelope. Parameters for magnitude-dependent haptic effects include, but are not limited to magnitude, duration and envelope. The described haptic effects and assignments shown above are illustrative only, and it should be recognized that a multitude of haptic effects and assignments may be used. The generated effects also have an optional magnitude specification which is usually taken as the maximum value of the signal (normalized to 0-10000) over the segment.

FIG. 8 illustrates an example time-symbol representation of a sequence of haptic events for a musical piece associated with the input audio signal discussed above. As shown in FIG. 8, the time-symbol representation 800 includes a time-frequency graph of the input audio signal 802. In addition, the representation 800 includes the low frequency sub-band, designated as Bass 804; the high frequency sub-band, designated as High Pass 806; and two medium frequency sub-bands, designated as Vocal 808 and Mid Accent 810.

As shown in FIG. 8, the system maps the haptic events in the each sub-band such that only one haptic event occurs at a time and is separated from the neighboring haptic effects by a designated time duration. In an embodiment, the system will allow more than one haptic event to occur at a time where the haptic effect profile for each event is not similar to one another. For example, as shown in FIG. 8, the system will allow strong magnitude dependent effects 808A, 808B and short periodic effects 804A, 806A to be overlapped considering they would be effectively felt by the user as two separate events. In the example representation shown in FIG. 8, the system is configured to give priority to the low-frequency haptic events over the high-frequency haptic events while the medium-frequency events are allowed to overlap with the high and low frequency events. It should be noted that the system is configurable by the user, the end device, or by the input audio signal itself, to give priority and overlapping rights to any or all of the frequency sub-bands, and is not limited to that shown in FIG. 8.

The above discusses one or more embodiments in which the system is able to automatically receive, identify and produce haptic events which correspond with the sampled audio signal and are output in a pleasant manner to the user. It is also possible, in an embodiment, that the received file is processed by the system in a real time manner, whereby the file is compressed and includes the haptic event information therein such that system more easily and quickly processes and outputs the haptic events from the embedded data. In particular, the embedded data is preferably in a compressed digital audio file format including, but are not limited to MP3, MP4, AAC, ASX, Ogg and WMA formats. Compressed digital audio formats are suitable for automated, real-time and/or offline use by the end device, whereby the compressed audio file is able to store frequency sub-band information which is used by the system to process and generate haptic events.

By using sub-band frequency coefficients already in the audio file, the system need not perform the intensive computations described in relation to FIG. 13. In other words, the system is able to use the already existing frequency sub-band coefficients in the audio file to generate the haptic events in quicker manner by using the digital audio file's already existing sub-band values. FIG. 12 illustrates a block diagram of a system using the embedded data and the frequency sub-band coefficients to output haptic events. In particular, the system 1200 preferably includes a processor 1202, a memory 1204, a

14

decoder 1206, a haptic playback engine 1208 and an actuator 1210. As shown in FIG. 12, a compressed audio file is received by the device 1200 wirelessly or via a wired connection, whereby the audio file is preferably stored in a memory 1204. The audio file preferably includes embedded data in the form of sub-band frequency coefficient information. The embedded data is preferably decoded by the decoder 1206 within the end device to extract the sub-band frequency coefficients for each frame. Alternatively, the decoding may be performed on a device other than the end device, such as a remote server. The extracted information is provided to the haptic playback engine 1208 which associates the extracted information with stored or predefined haptic effects. The device 1200 preferably synchronizes the haptic effects with the associated audio events to output signals to the actuator 1210, whereby the actuator 1210 outputs haptic events. In an embodiment, the embedded data in the file is modified by the device 1200 itself as the file is played by the device 1200 as a sort of fine tuning or self correction feedback method. This may be done by the device 1200 analyzing the output sound features via a microphone as they are played back by the device's speakers. In the example, the system is able to send the sub-band frequency coefficients to a kernel of the haptic playback engine 1208 to modify the magnitudes of the haptic events after they have processed and played by the device 1200. The modified magnitudes may then be stored by the device 1200, whereby the device 1200 retrieves the modified values from memory and plays the haptic events using the modified data the next time the file is played by the device 1200.

Upon the decoder 1206 receiving the audio file, the decoder analyzes and extracts the sub-band coefficients to allow quick processing and output of haptic events. In an example, the lowest sub-band of an MP3 file is useful for beat or rhythm detection considering that the lowest sub-band of an MP3 file typically includes frequencies less than 100 Hz. The system 1200 utilizes any appropriate algorithm to instruct the haptic playback engine 1208 to output signals to the actuator, whereby the actuator will output haptic events associated with the audio events. In particular, the haptic playback engine will determine which audio events are to receive a corresponding haptic effect, based on the monitored audio events which cross a threshold frequency set by the algorithm. An example algorithm is that discussed above used in relation to analyzing sample audio data. The haptic playback engine 1208 may retrieve stored haptic effect definitions from the memory 1204, whereby definitions may include event duration, magnitude and/or frequency as well as the type of effect to output by the actuator (e.g. vibration, jolt). The actuator 1210 upon receiving the information from the haptic playback engine 1208, will output haptic events with the defined haptic characteristics that are automatically synchronized with the playback of the associated sound. In other words, the system 1200 will output in real-time or in an off-line mode, the defined haptic effects for each haptic event in the low frequency sub-band to ensure that all bass or low frequency beats have a consistent haptic effect associated with them.

For higher frequency sounds, such as vocals and other higher pitch sounds, the system 1200 may add energy from multiple sub-bands to produce haptic events which correspond with the higher frequency sounds. In particular, frequency sub-bands above 100 Hz and below 400 Hz are typically well suited for fundamental mid-range sounds and voice detection in the audio. The system 1200 preferably outputs a low magnitude-dependent effect whose magnitude varies with the energy in the higher frequency sub-bands. The sys-

tem **1200** preferably applies low-pass filtering of the raw energy to eliminate spurious peaks in the energy, whereby the system is able to low-pass filter the energy in real-time using software. In particular, the system attains the low-pass filter the energy by averaging the energy over non-overlapping windows whose length is based on the frequency at which the haptic playback engine **1208** is operating. In an embodiment, the haptic playback engine operates at 200 Hz, the signal can be averaged for 5 ms and corresponding value representing the magnitude of the magnitude-dependent haptic effect can be sent to the haptic playback engine **1208**. The remaining peaks after low-pass filtering can be used to trigger haptic events which are above the threshold of the average value, whereby the duration of the haptic events that are instructed to be output by the actuator **1210** will depend on the duration of the peaks themselves. For example, a long duration of a peak may be assumed by the system **100** to be a sustaining note of a voice or guitar note, whereby the haptic playback engine **1208** instructs the actuator **1210** to output a haptic effect that has a duration which corresponds to that particular sustained note.

Since there may be energy in other sub-bands which are even higher than 400 Hz, the system **1200** takes into account the peaks in those remaining sub-bands. This would assure that the system **100** would output haptic effects which correspond to cymbals and other high pitch sounds. A threshold algorithm as that described above would be appropriate, although other algorithms are contemplated. It should be noted that this embodiment may utilize the priority clip **334** and effect mapping **336** modules described in FIG. **3** to produce more distinct, discreet haptic events. However, the digital audio file may be conditioned to already include the needed clipping and effect mapping information to render these modules as optional.

The system is also able to receive and process representationally structured encoded music files including, but not limited to MIDI files, to produce haptic events which correspond with the encoded music files. It should be noted that although the representationally structured files are described herein as music files, the representationally structured files may be files having sound effects, or other events associated with audio.

FIG. **9** is a time-note representation of a series of MIDI events making up a musical piece in accordance with an embodiment. The MIDI file format may include 16 channels of simultaneous instruments, whereby each channel is capable of having events up to 127 unique pitches (called keys) that can be played. In addition, the MIDI file format includes a channel reserved for percussion instruments which are generally pitchless. Percussion instruments are distributed across the range of keys in percussion channel.

FIG. **10** illustrates a time-instrument-note representation of a series of MIDI events making up a musical piece in accordance with an embodiment. In a MIDI music file, every note of every instrument is an event that may be designated by the system to be a haptic event. However, considering the physical and performance limitations on actuators, the system analyzes and processes the MIDI file to produce discrete haptic events which produce a pleasurable haptic experience to the user.

FIGS. **11A**, **11B**, and **11C** together illustrate a process flow diagram used by the system to automatically process MIDI files and produce discrete haptic events in the end-player device. In general, the system analyzes the MIDI data and extracts a melody and/or percussion event sequence from the structured representation. The system then generates a score for each channel corresponding to each instrument, whereby

the score of a non-percussive channel is related to the variability of notes in that channel. This has been found empirically to be effective at selecting the melody from a set of otherwise unknown input channels. For percussive instruments, the scoring strategy relies on a priori knowledge of the dominance of various percussive instruments. For example, the bass drum is most likely to be the dominant percussive channel, and so the notes associated with the bass drum in the percussive channel generally receives a higher score.

In addition to scoring the input channels from a MIDI sequence, the system and method performs one or more clipping operations on the events to allow discrete haptic events to be produced in the end-device. In an embodiment, the system clips one or more notes to a desired duration and processes the channels to remove overlapping notes, such as chords. In an embodiment, the system is configurable based on a number of parameters which may be manipulated to control the relative priority of one or more channels over other channels (e.g. percussion vs. melody).

As shown in FIG. **11A**, selected ones, some, or all channels of the MIDI sequence are received in the system (**1102**). The sequence may be imported into the memory in the end device, a server in communication with the end device, and/or other intermediate component, computer or processor. In an embodiment, information from the imported MIDI file which is not actually used to produce the haptic events is actually deleted from memory. In an embodiment, information not actually used to produce the haptic events may be retained by the system to allow reconfiguration or fine tuning of the haptic events by a developer or the end user.

In an embodiment, the system executes various pre-processing procedures to the file after it is received. In an embodiment, the system executes pre-note identification and next-note identification techniques on the events by analyzing the timeline of the events (block **1104** in FIG. **11A**). At block **1104**, in one embodiment, each channel is processed to set up links from an event to the previous event in the same channel. Each channel is also processed to set up links from an event to the next event in the same channel. In an embodiment, the system analyzes the timeline of the entire structured audio representation file at one time. In another embodiment, the system analyzes portions of the timeline of the audio representation file at a time. This allows the system to quickly process large audio files having a long timeline (e.g. sound effects in a movie).

As shown in FIG. **11A**, the system then identifies melodic and percussive events of interest, as shown at block **1106** by identifying the channels where melody and percussive events occur. Upon identifying the melodic and percussive events, the system is able to effectively utilize the identified events to score the melodic events (block **1116**) and the percussive events (block **1132**) in FIG. **11B**.

As shown in FIG. **11**, the system optionally processes each channel to remove chords, in an embodiment (**1108**). In an embodiment, the system identifies chords from the MIDI file as those events that start within a certain duration of each other on the same channel and are on non-percussive instrument channels. In an embodiment, this duration is set at 15 ms, although other time durations are contemplated. In an embodiment, once the system identifies chords in the MIDI event channels, the system retains only the events having the highest pitch and discards the other events which make up the chord from the timeline. In another embodiment, the system eliminates the highest pitch events and retains the lower or lowest pitch events. As will be discussed in more detail below, removal of chords from the timeline reduces the score given

to a channel that has many chords, thereby aiding the system in identifying melodies in the timeline.

At **1110**, the system identifies channel pairs that have identical or nearly identical notes at the same or substantially same time. This is often the case when two or more instruments are playing in harmony (e.g. two guitars simultaneously playing a same riff). For each channel, a time sampled vector of on-times is generated, wherein the on-times are the points where events occur. The system accomplishes this by examining each channel's events over the timeline and setting a value 1 for the time interval during which an event is occurring. Otherwise a value of 0 is set in the vector. This generates a set of vectors of length, n:

$$n = \text{floor}\left(\frac{T}{t_s}\right) \quad (2)$$

where T is the total duration of the MIDI input file and t_s is the sampling interval.

To identify channels that have notes that overlap, a correlation is calculated for each of the channels:

$$\text{cor}(v_i, v_j) = \frac{\text{cov}(v_i, v_j)}{\sigma_i \sigma_j} = \frac{\langle v_i v_j \rangle - \langle v_i \rangle \langle v_j \rangle}{\sigma_i \sigma_j} \quad (3)$$

where v_i, v_j , are time sampled vectors, and σ_i is the standard deviation of vector v_i , treated as a time series. If the correlation of two or more channels exceeds a correlation threshold value, then a portion or an entire channel may be eliminated from the timeline.

For example, referring back to FIG. 9, the channels **902** and **904** are shown between lines **900** and **908** to be substantially identical. Upon the system performing the above calculations on channels **902** and **904**, the system will eliminate one of the two channels considering that they are playing the same melody at the same time. Which of the two channels which will be eliminated may be dependent on parameters set by the user and/or the system.

As shown in FIG. 11A, the system restricts the events to desired length by setting a maximum and minimum length by using a clipping process (**1112**). The system clips the events which are shorter than a specified minimum duration to be at least as long as the minimum duration. Additionally, events longer than a specified maximum duration are changed or clipped to be no longer than the maximum duration. In addition, two or more events that have a spacing duration between them to be less than a pre-specified minimum are changed to have at least the minimum spacing duration. This may be done by shortening one or both of the events in the sequence to produce the minimum spacing therebetween.

Turning now to FIG. 11B, once the system has completed importing and pre-processing each channel, the system initiates scoring of each channel in the received file (**1116**). It should be noted, in an embodiment, that the system is able to begin the scoring process as the importing/pre-processing of the received file is being executed. In an embodiment, the system begins the scoring process after the importing/pre-processing of the file is performed.

In an embodiment, the system scores the channels using two sets of rules. The first rule set is designed to give a higher score to the channels that have some variability as those channels are likely to be carrying the melody. The second rule

set provides a ranking to percussive channels in terms of their traditional importance in defining the rhythm in the song.

Scoring is accomplished by examining all of the events in the timeline. Each event is passed through a scoring filter that assigns a score to the individual event. Once all events have been processed, a second loop through the timeline derives the score for all events in each channel, yielding a total score per channel. In an embodiment, this is done by simply accumulating the scores of the events. In another embodiment, this is done using an appropriate algorithm. As shown in FIG. **11B**, the system scores the melodic and percussive events separately in an embodiment, although the scoring may be done simultaneously or one after another. In an embodiment, the system is capable of scoring the melodic and percussive events all together, whereby information determined for one type of event (i.e. melodic or percussive) may be used to analyze or evaluate the other type of event (i.e. percussive or melodic).

For melodic events in the timeline, the system utilizes a subset of rules in scoring the events, as shown at **1116** in FIG. **11B**. In an embodiment, each of the subset rules are executed by the system simultaneously. In an embodiment, one or more of the subset rules are executed by the system in a sequence.

As shown in FIG. **11B**, the system scores the pitch change between events in accordance with block **1118** of an embodiment. As in block **1118**, the system calculates the absolute value of the difference between the pitch of the current event and the pitch of one or more previous events, whereby the pitches each have a determined value. The system is able to assign a value to the pitch from the channel data inherently encoded in the audio representation file. In an embodiment, the difference is output as the pitch score: In an embodiment, the difference value is scaled by a predetermined factor (e.g. 500) to get the pitch score.

As shown in FIG. **11B**, the system scores the start time between events in accordance with block **1120** of an embodiment. The system in block **1120** analyzes the duration of the events to determine whether a rhythm is being played in the channel. In an embodiment, in block **1120** the difference in start times is calculated between an event and the immediately preceding event. In an embodiment, in block **1120** the difference in start times is calculated between a preceding event and an event previous to the preceding event. In an embodiment, the system weights the differences before outputting a start time score. In an embodiment, the weighted amount is of a factor of 5. It is contemplated, however, that the weighted value can be a factor other than 5. Depending on other rhythms in the file or the genre of the song, the system may score the durations higher or lower such that the system outputs appropriately resolved haptic events.

As shown in FIG. **11B**, the system scores the magnitude or intensity of the event in accordance with block **1122** of an embodiment. Block **1122** designates a score equal based upon a function of the magnitude of the event. The system is able to determine the magnitude of each event from the channel data inherently encoded in the structured representation file.

As shown in FIG. **11B**, the system scores the duration of an event in accordance with block **1124** in an embodiment. Block **1124** designates a score based upon a function of the duration of the event. In an embodiment, the system assigns a higher score for events which have a longer duration than events which have a shorter duration. In another embodiment, the system assigns a lower score for events which have a longer duration than events which have a shorter duration

As shown in FIG. **11B**, the system scores the change in duration of an event in accordance with block **1126** of an embodiment. In particular, the system designates a score

based upon a change in duration between the current event and a previous event in block 1126.

As shown in FIG. 11B, the system scores the change in duration of an event in accordance with block 1128 of an embodiment. In particular, the system designates a score based upon a duration of silence before each note within the event in block 1128. For example, if the system identifies an event that occurs after a long duration of silence in a particular channel, the system may assign a high score to the event such that it will most likely be output as a haptic event. An example of this would be a cymbal crashing at the end of a drum roll.

In an embodiment, as illustrated by block 1130, melodic events are optionally scored by the system in relation to their entropy. In the process of evaluating the rules, the system may utilize a relationship between the scores assigned to a channel and the acoustic entropy associated with that channel. To estimate the entropy of each melodic channel, a distribution of notes is constructed by the system. The traditional 12 tone scale is used to define equivalence classes $\{(k), k=1..12\}$ of note pitches. Each event is classified according to which tone in the 12 tone scale is associated with the event's key. A distribution is built by scaling each event contribution using a perceptual accent rule, whereby weighting, w , is determined by equation 3:

$$w = \left(1 - e^{-\frac{d}{\tau}}\right)^{\alpha} \quad (4)$$

where variable d is the duration (in seconds) of the silence between the current event and the previous event. Variable τ is the saturation rest length (taken to be 0.5 s) and α is the minimum discriminable duration (taken to be 2 s). It should be noted that other values for saturation rest length and minimum discriminable duration are contemplated and are not limited to the values mentioned herein.

The entropy of this distribution is calculated using the formula in equation 4:

$$e = -\sum_{k=1}^{12} p(k) \log(p(k)) \quad (5)$$

where $p(k)$ are the classes of tonal pitches from 1 to 12 (for a 12 tone scale).

In addition to scoring the melodic events, the system scores percussive events as shown by block 1132 in FIG. 11B. In an embodiment, the system utilizes two rules in scoring the percussive events. In particular, the system scores the duration of the silence before each percussive note. The duration of silence is considered to be milliseconds, and the score is weighted in an embodiment. In an embodiment, the scored silence value is divided by a value of 4, although other values are contemplated

As shown in FIG. 11B, the system assigns a value to each percussive instrument depending on the type of percussion instrument. In an embodiment, a weight value of 1 to 5 is assigned by the system for each percussion instrument such that the more dominant instruments receive a higher value. For example, events attributed to a bass drum instrument are given a value of 5 whereas events attributed at a high-hat symbol is given a value of 1. In an embodiment, the value is weighted by a factor (e.g. 100) in producing the per event score. The total event score for the percussive events is based upon a subset of these rules.

In an embodiment, the scoring multipliers for both percussive and melodic rules are weighted by the system to emphasize melody instruments over percussive ones when absolute rankings of channels are generated. This processing occurs at Block 1138 where channel scores are generated. The weightings may be based on the genre of music, type of audio file (e.g. music vs. sound effects of video), user preference, type of end device, etc.

Turning now to FIG. 11C, following the generation of scores per channel (block 1138), the system is able to sort the channels based on score values, as shown by block 1142. In an embodiment, the system sorts the melodic channels and percussive channels separately, although the system is capable of sorting both types of channels together. In an embodiment, the scored channels are sorted in descending order, whereby the channels with the highest scores are ranked as "high". In an embodiment, the scored channels are sorted in ascending order. In an embodiment, the system sorts channels which are within a desired range of scores or only chooses channels with desired scores. In an embodiment, the system ranks the scores highest to lowest in which the highest-ranked events will be output as a haptic event and the lowest-ranked events will not be output as a haptic event.

Upon the system ranking or choosing the channels based on score, the system is able to determine which channels will provide the events upon which the haptic effects will be based. In an embodiment, the system generates haptic effects at Block 1144 using the following pseudo-code:

```

While channels remain
  For each empty duration > 400 ms in the Vibe channel
    Fill the empty duration, with a 100 ms cushion at the
beginning
  and end of the gap with the highest scoring channel in
that interval.
end

```

In other words, the system automatically maps the highest ranked haptic events from the beginning to the end of the song. Thereafter, the system "fills in the blanks" and again maps the next highest ranked haptic events which are able to be placed within the empty or non-haptic event portions of the song. This process is repeated until the maximum number of allowed haptic events are mapped in the song, taking into consideration of actuator resolution, duration cushions, user preference, haptic effect styles and type of song. It should be noted that the above is only an example pseudo code and the system may utilize different duration cushions as well as utilize the lowest scoring channel or other criteria.

As the events are assigned to be a haptic event, the system clips the haptic event to have a duration within a desired range. In an embodiment, the clipping range is between 200 ms and 300 ms, although greater or lesser durations are contemplated and may depend on the properties of the haptic actuator. In addition, the start time of the event can be offset by a desired amount to ensure perceptual coupling between audio and haptic events on different types of actuators. In an embodiment, the intensity of the haptic event may be adjusted in the system. For example, the minimum duration may be set to a lower value and the cushioning time may be increased.

As shown in FIG. 11C, the system removes percussive overlap in an embodiment. The system optionally independently constructs a melodic and percussive channel using the 'fill in the blanks' algorithm, and then merges together them to produce the final mapped haptic events. This is likely to be most effective when only "strong" effects are being used, as

overlapping sharp effects can yield unpredictable vibe behavior. Alternatively it is possible for the system to attenuate the magnitude of haptic events that have overlapping percussive events, whereby the attenuated haptic events are then output at maximum magnitude. This provides the end device with the characteristic of preserving the melody yet displaying perceptual accentuation for the rhythm.

In an embodiment, the system is able to add Custom Fades (Block 1150) at certain points in the timeline of the structured representation signal. A designer may choose to replace a note of long duration with a shorter effect that fades out (e.g. 500 ms). Also, the end of a phrase or melodic line can be made more interesting by adding a similar fade effect.

In an embodiment, the system looks for events with a long (more than about 500 milliseconds) duration as they are added to the timeline in accordance with the above rules. If there is also a large time gap (about 1000 milliseconds) between the particular event and the next event, the system may automatically fade in or out the particular event. To implement this approach, the system identifies and builds a list of such haptic events which have a haptic effect characteristic or profile that fades in and/or out. After the entire timeline has been constructed, the system replaces the existing haptic events with the faded haptic events from the list. The Fade effect may be implemented as a periodic or magnitude dependent effect that decays for its entire duration.

The methods for converting digital sampled audio and/or structured representation files described above allow for the automatic conversion of notes to haptic events. Once converted, these haptic event sequences are able to be stored and be re-distributed to other end-devices by an appropriate manner. For example, the haptic events sequences may be stored as an output file in a server that is in communication with one or more clients over a network. Upon establishing a communication link with the client, the server may deliver the output file electronically to be played in the client. Likewise, the haptic sequences can be used in a variety of settings known in the art. For example, to notify a user of a phone call or an event such as an appointment, ring tone, alarm, incoming message such as a weather report or text message and the like. In an embodiment, the structured representation files may be applied to a karaoke song in which the end device (e.g. karaoke microphone) outputs haptic effects after automatic conversion of the file to cue the singer of the vocals. In an embodiment, the end device is able to automatically convert, map and output haptic event sequences for sound effects or other audio in a video, video game, music video or movie file which is downloadable onto the end device.

While embodiments and applications of this invention have been shown and described, it would be apparent to those skilled in the art having the benefit of this disclosure that many more modifications than mentioned above are possible without departing from the inventive concepts herein. The invention, therefore, is not to be restricted except in the spirit of the appended claims.

We claim:

1. A method comprising:

receiving a compressed digital audio file that comprises embedded sub-band frequency coefficient information; decoding the digital audio file to extract the sub-band frequency coefficient information; identifying a plurality of audio events using the sub-band frequency coefficient information; and assigning a haptic effect to at least one of the events to produce a haptic event to be output by an actuator; analyzing an output sound of the digital audio file;

based on the analyzing, modifying the sub-band frequency coefficient information; and storing the modified sub-band frequency coefficient information;

wherein the digital audio file is processed in a real time manner, wherein the haptic effect is processed and output as the digital audio file is being received.

2. The method of claim 1, wherein the digital audio file contains frequency sub-band signals therein from where the plurality of audio events are identified.

3. The method of claim 2, wherein the digital audio file is in a Mp3 format.

4. The method of claim 1, wherein the processing of the digital audio file further comprises computing a spectral decomposition of the digital audio file.

5. The method of claim 4, further comprising segmenting at least one of the frequency sub-band signals into the plurality of events and designating a minimum separation time between events.

6. The method of claim 4, wherein the segmenting further comprises designating a minimum actuator start-up time prior to the haptic event.

7. The method of claim 4, wherein the segmenting further comprises designating a minimum duration of time for each haptic event in a plurality of haptic events.

8. The method of claim 4, wherein the events segmented from the sub-band signal correspond to a user specified average number of haptic effects per second.

9. The method of claim 4, wherein the events segmented from the sub-band signal have an alias value below a maximum alias target value.

10. The method of claim 4, further comprising calculating an average over a designated period of time for a parameter of one or more sub-band signals.

11. The method of claim 10, wherein the segmenting of at least one sub-band signal further comprises:

designating an event if a short term value of the parameter of the sub-band signal exceeds a multiple of the average for the parameter.

12. The method of claim 1, wherein the assigning further comprises designating a minimum separation time between events.

13. The method of claim 1, wherein the assigning further comprises designating a minimum actuator start-up time prior to a first haptic event.

14. The method of claim 1, wherein the haptic event data is stored on a server capable of being in communication with a client over a network, wherein the server delivers the haptic event to the client.

15. An apparatus comprising:

a circuit for receiving a compressed digital audio file that comprises embedded sub-band frequency coefficient information;

a circuit for decoding the digital audio file to extract the sub-band frequency coefficient information;

a circuit for identifying a plurality of audio events using the sub-band frequency coefficient information;

a circuit for assigning a haptic effect to at least one of the events to produce a haptic event;

an actuator configured to output the haptic event;

a circuit for analyzing an output sound of the digital audio file;

a circuit for, based on the analyzing, modifying the sub-band frequency coefficient information; and

a circuit for storing the modified sub-band frequency coefficient information

23

wherein the apparatus is configured to process the digital audio file in a real time manner, wherein the haptic effect is processed and output as the digital audio file is being received.

16. The apparatus of claim 15, further comprising: a circuit for segmenting the at least one of the sub-band signals into the plurality of audio events, wherein the circuit for segmenting further comprising means for computing a spectral decomposition of the digital audio file.

17. The apparatus of claim 16, wherein the circuit for segmenting further comprises:
means for designating a minimum separation time between events.

18. The apparatus of claim 16, wherein the circuit for segmenting further comprises:
means for designating a minimum actuator start-up time prior to a first haptic event.

19. The apparatus of claim 16, wherein the circuit for segmenting further comprises:
means for designating a minimum duration of time for each haptic event in a plurality of haptic events.

20. The apparatus of claim 15, wherein the circuit for assigning further comprises:
designating a minimum separation time between events.

21. The apparatus of claim 15, wherein the events within the sub-band signal correspond to a user specified average number of haptic effects per second.

22. The apparatus of claim 15, wherein the events within the coefficient information have an alias value below a maximum alias target value.

23. The apparatus of claim 15, further comprising:
means for calculating an average over a designated period of time for a parameter of one or more coefficient information.

24

24. The apparatus of claim 23 wherein the circuit for segmenting further comprises:
designating an event if a short term value of the parameter of the sub-band signal exceeds a multiple of the average for the parameter.

25. A non-transitory computer-readable medium having instructions stored thereon that, when executed by a processor, cause the processor to generate haptic effects, the generating comprising:

receiving a compressed digital audio file that comprises embedded sub-band frequency coefficient information;
decoding the digital audio file to extract the sub-band frequency coefficient information

identifying a plurality of audio events using the sub-band frequency coefficient information;

assigning a haptic effect to at least one of the events to produce a haptic event to be output by an actuator;

analyzing an output sound of the digital audio file;
based on the analyzing, modifying the sub-band frequency coefficient information; and

storing the modified sub-band frequency coefficient information

wherein the digital audio file is processed in a real time manner, wherein the haptic effect is processed and output as the digital audio file is being received.

26. The non-transitory computer-readable medium of claim 25, wherein the digital audio file contains frequency sub-band signals therein from where the plurality of audio events are identified.

27. The non-transitory computer-readable medium of claim 25, wherein the processing of the digital audio file further comprises computing a spectral decomposition of the digital audio file.

* * * * *