



US008704366B2

(12) **United States Patent**
Shin et al.

(10) **Patent No.:** **US 8,704,366 B2**
(45) **Date of Patent:** **Apr. 22, 2014**

(54) **ULTRA THIN BUMPED WAFER WITH UNDER-FILM**

257/E23.002; 438/455, 458, 459, 464, 113, 438/114

See application file for complete search history.

(75) Inventors: **Junghoon Shin**, Choongbook (KR);
Sangho Lee, Kyounggi (KR); **Sungyoon Lee**, Inchon-si (KR)

(56) **References Cited**

(73) Assignee: **STATS ChipPAC, Ltd.**, Singapore (SG)

U.S. PATENT DOCUMENTS

(*) Notice: Subject to any disclaimer, the term of this patent is extended or adjusted under 35 U.S.C. 154(b) by 77 days.

5,400,950	A	3/1995	Myers et al.	
6,620,862	B2	9/2003	Ueda et al.	
6,787,921	B2	9/2004	Huang	
7,105,424	B2	9/2006	Tsai et al.	
7,413,927	B1	8/2008	Patwardhan et al.	
2002/0190224	A1*	12/2002	Tazaki	250/484.4
2003/0001283	A1*	1/2003	Kumamoto	257/778
2004/0043901	A1*	3/2004	Ono	503/200
2005/0008873	A1	1/2005	Noro et al.	
2005/0142696	A1	6/2005	Tsai	
2005/0142837	A1	6/2005	Tsai	

(21) Appl. No.: **12/911,592**

(22) Filed: **Oct. 25, 2010**

(65) **Prior Publication Data**

US 2011/0037172 A1 Feb. 17, 2011

Related U.S. Application Data

(62) Division of application No. 11/745,045, filed on May 7, 2007, now Pat. No. 7,838,391.

(51) **Int. Cl.**

H01L 23/48 (2006.01)
H01L 23/52 (2006.01)
H01L 29/40 (2006.01)

(52) **U.S. Cl.**

USPC **257/737**; 257/798; 257/E23.069

(58) **Field of Classification Search**

USPC 257/737, E23.069, 778, 783, 798,

* cited by examiner

Primary Examiner — Chuong A Luu

Assistant Examiner — Nga Doan

(74) *Attorney, Agent, or Firm* — Robert D. Atkins; Patent Law Group: Atkins & Associates, P.C.

(57) **ABSTRACT**

A semiconductor device includes a wafer and a dicing saw tape that is laminated to a back surface of the wafer. An active surface of the wafer is opposite the back surface of the wafer. The semiconductor device further includes a lamination tape disposed in contact with the wafer. The lamination tape includes an under-film layer contacting the active surface of the wafer. The lamination tape further includes an adhesive layer contacting the under-film layer.

27 Claims, 4 Drawing Sheets

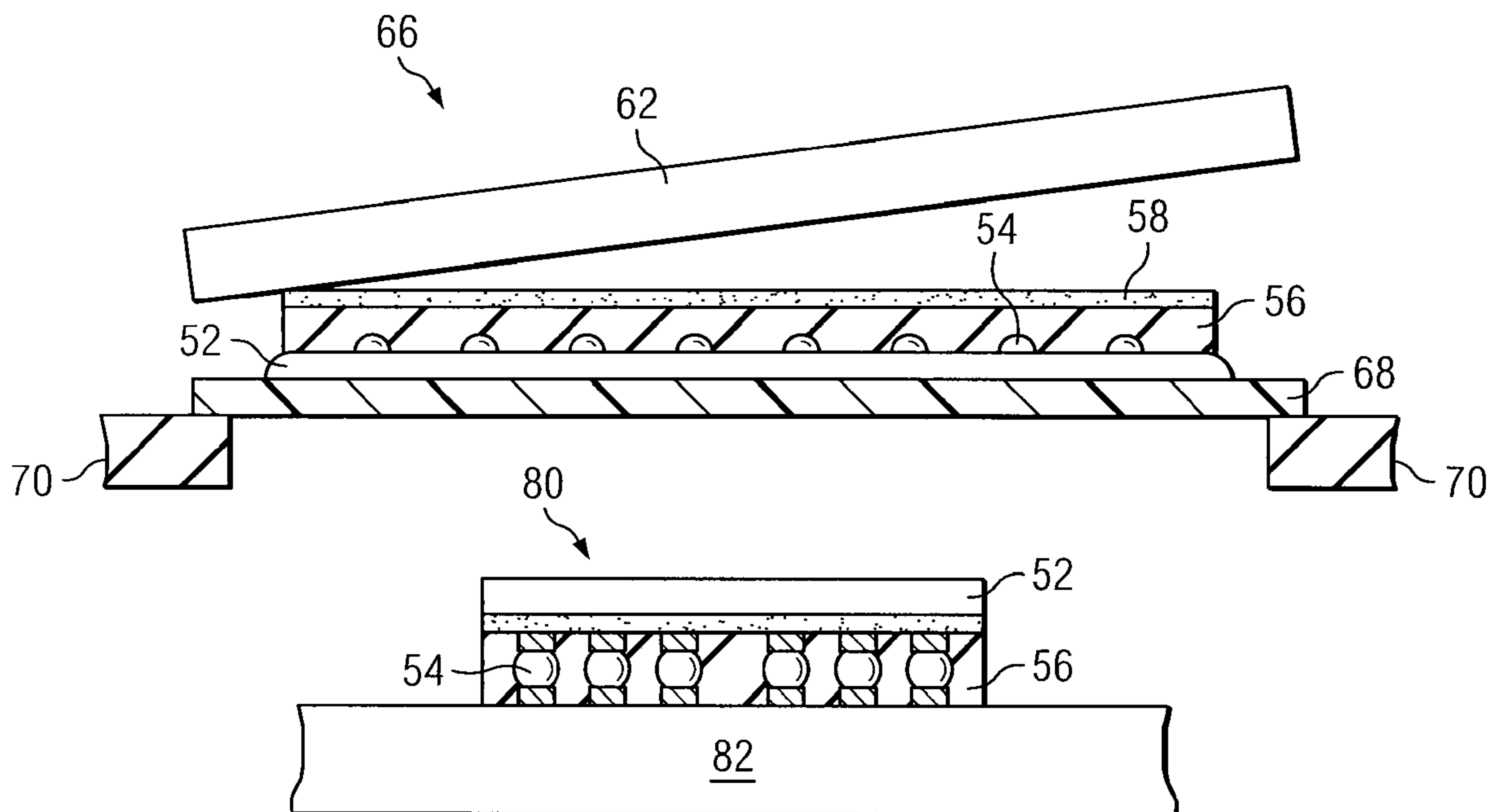

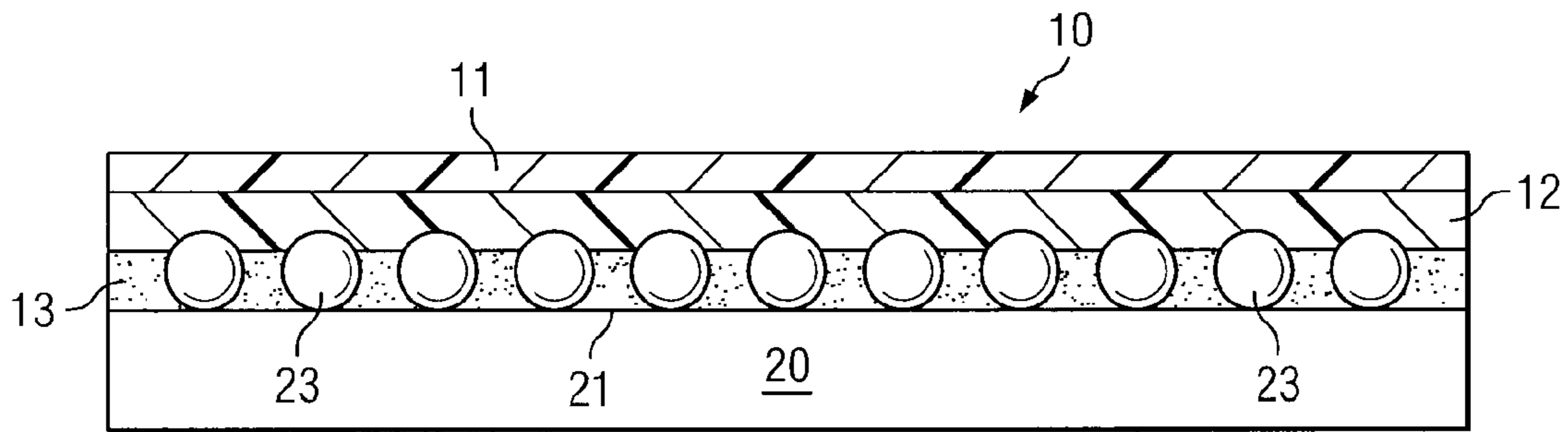

FIG. 1
(PRIOR ART)

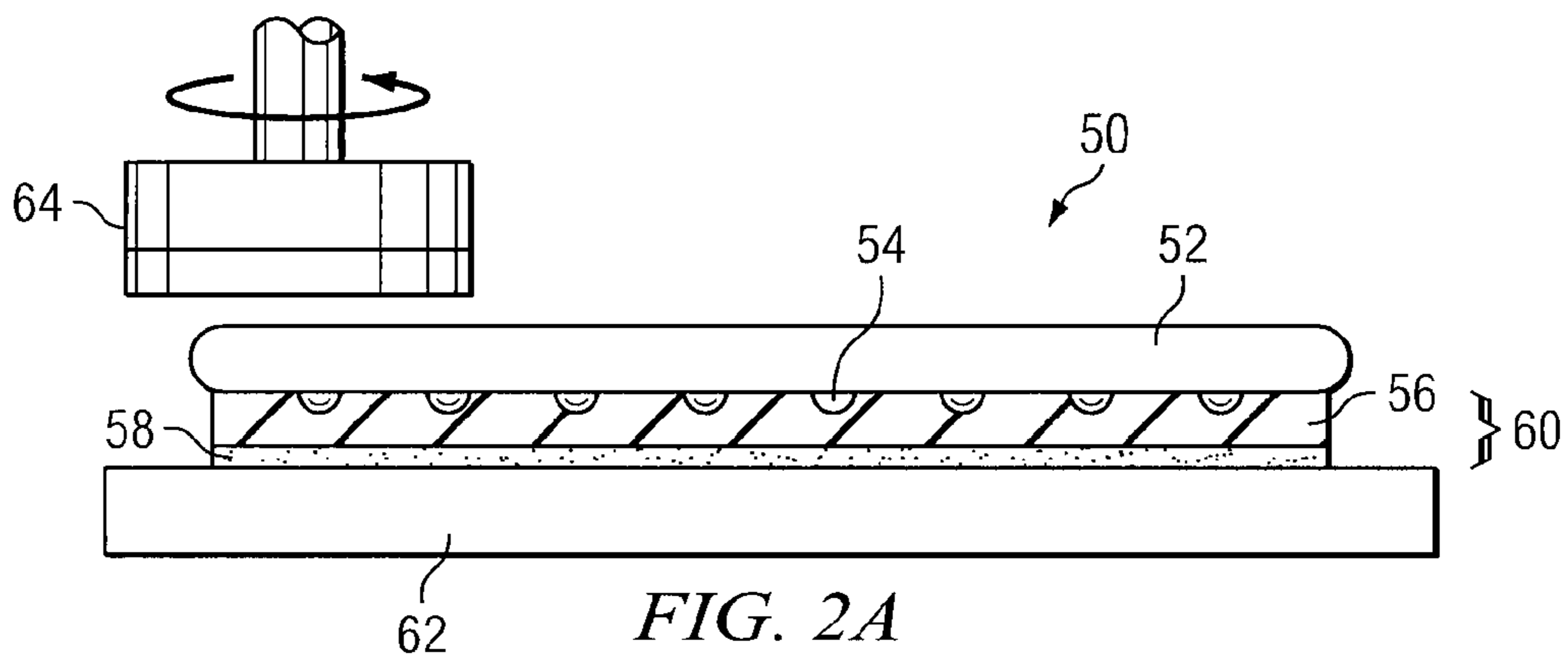

FIG. 2A

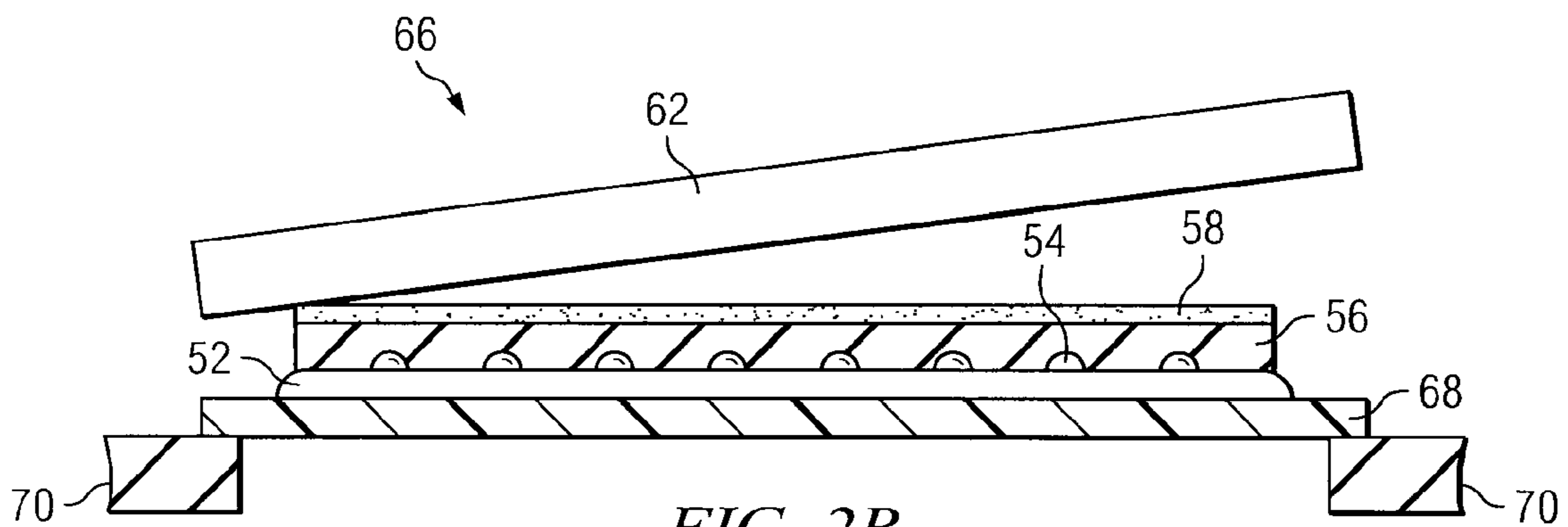
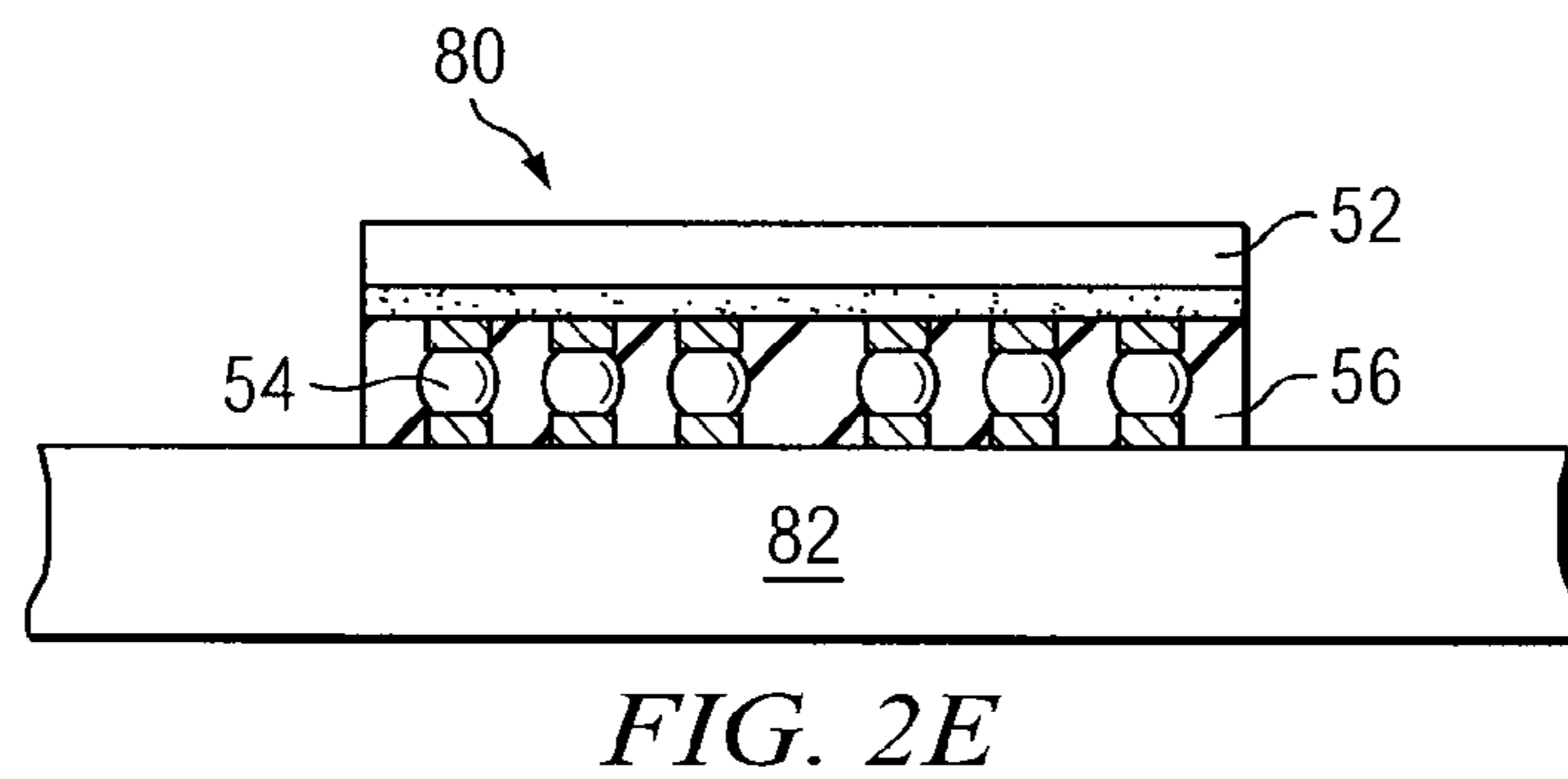
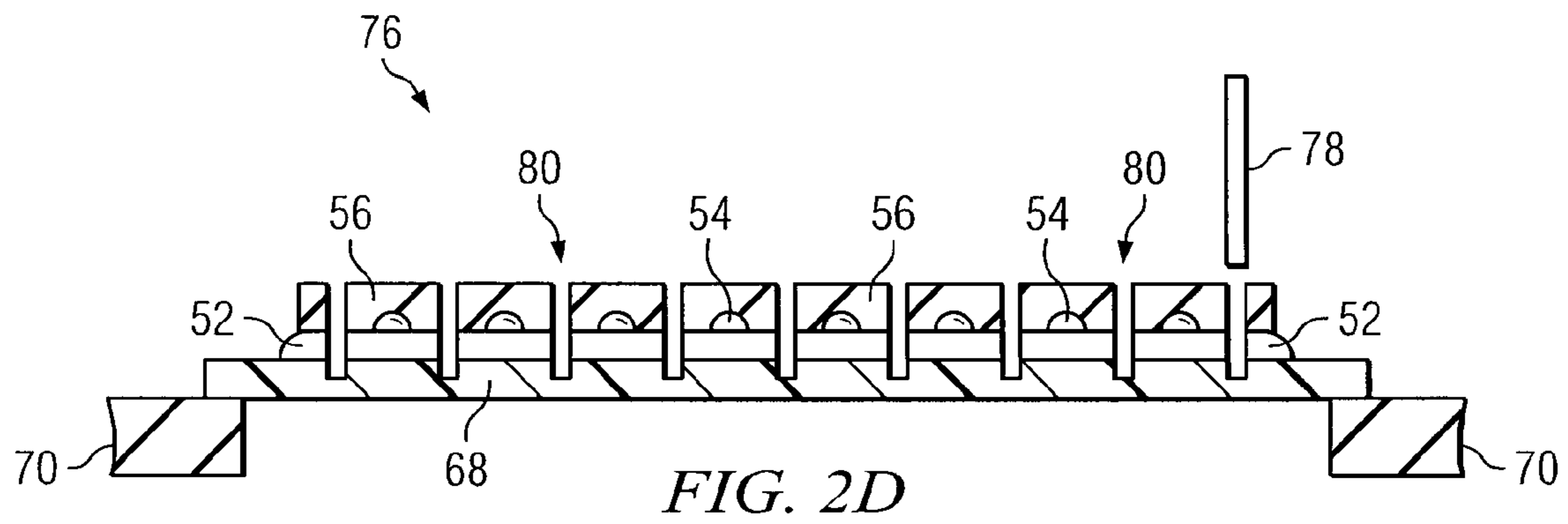
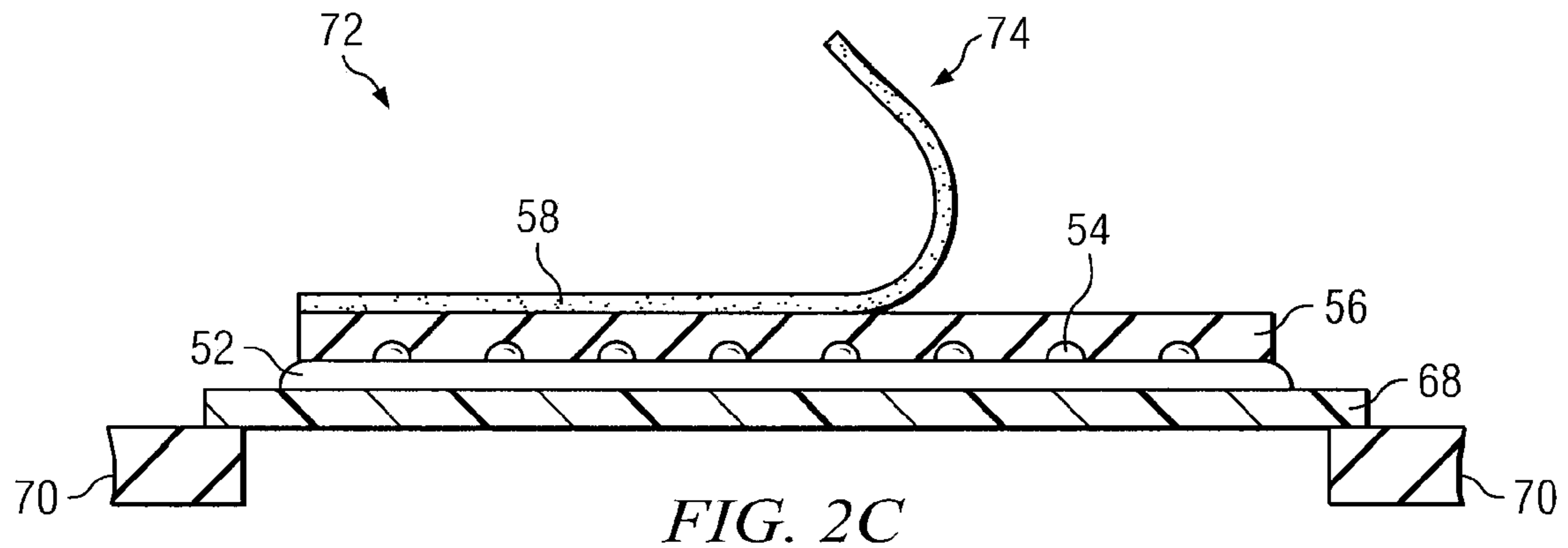
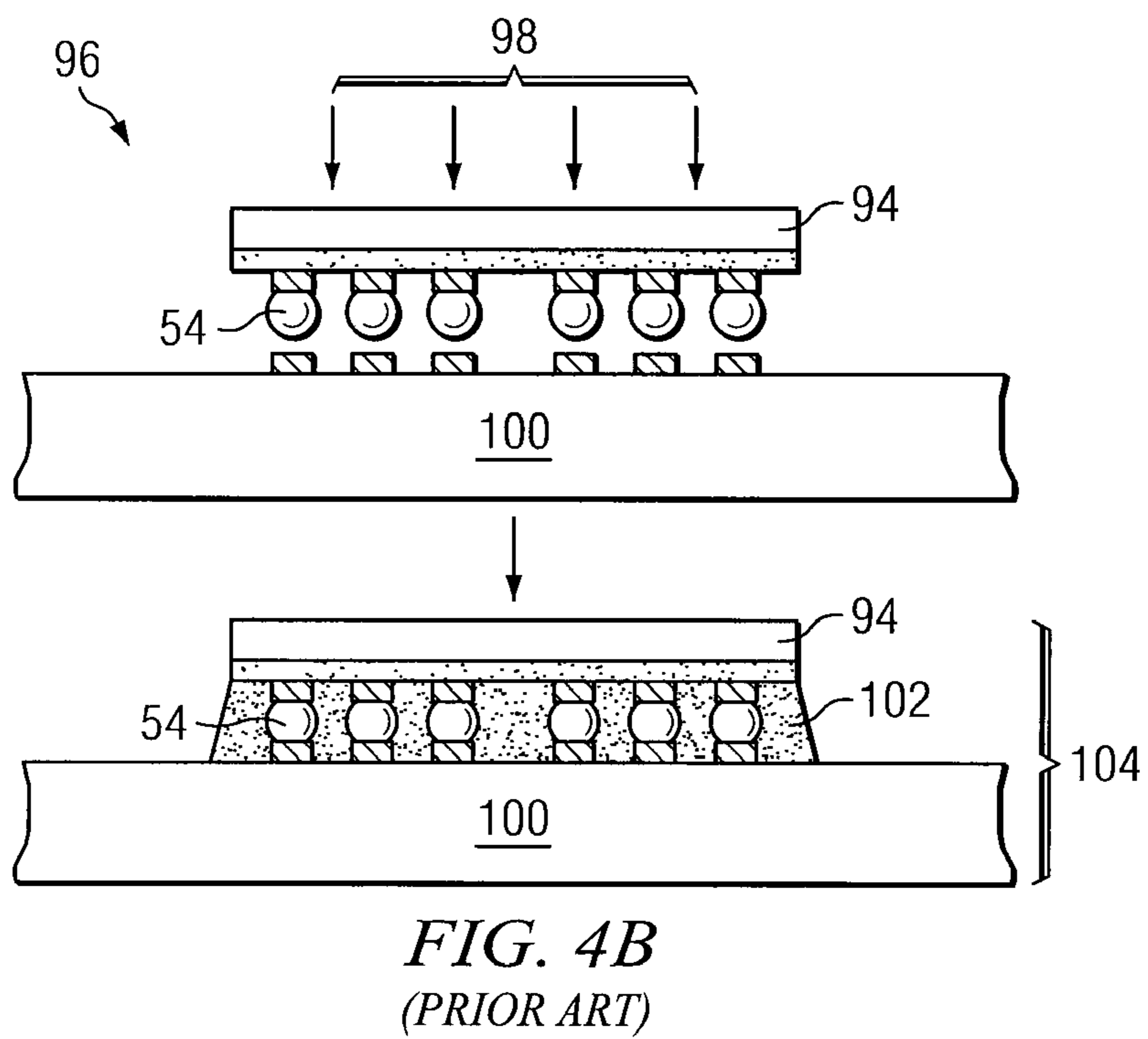
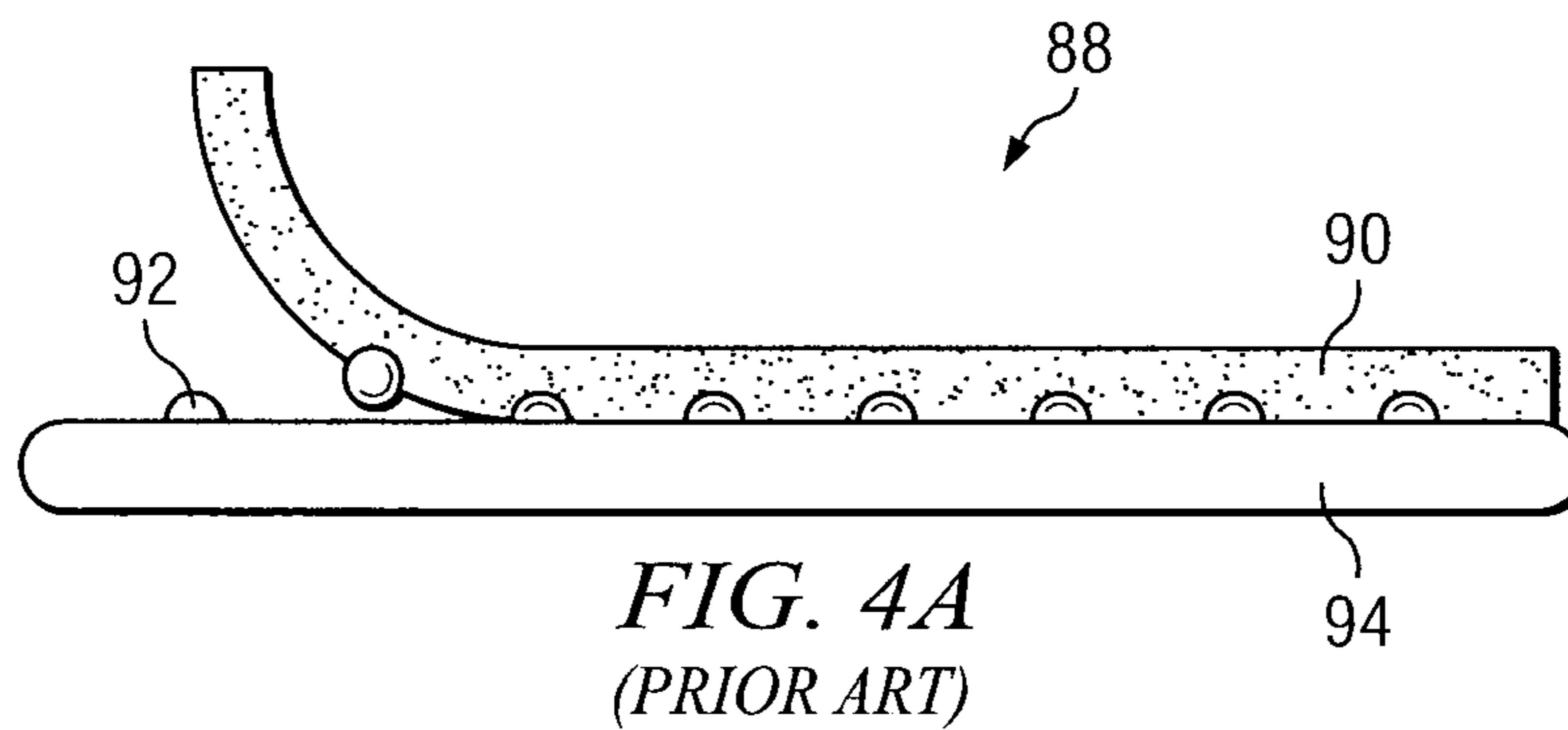
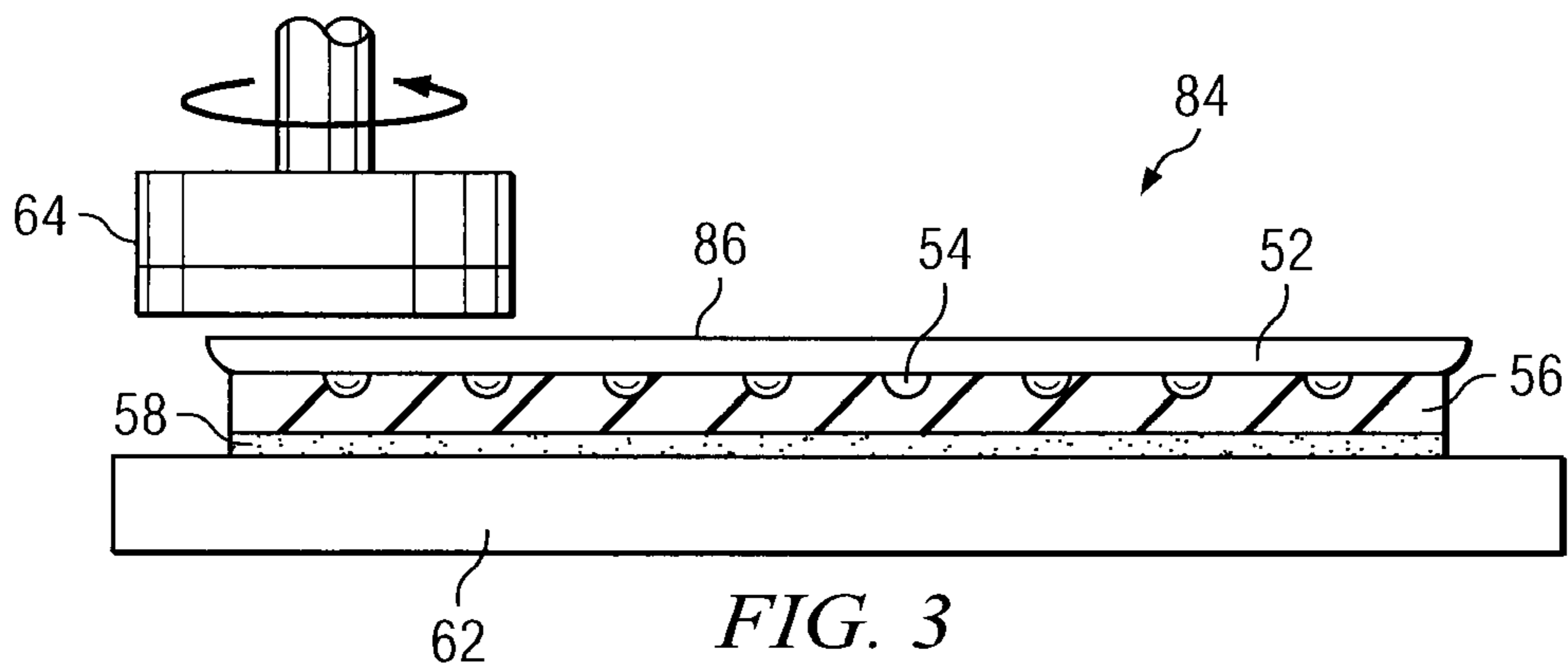
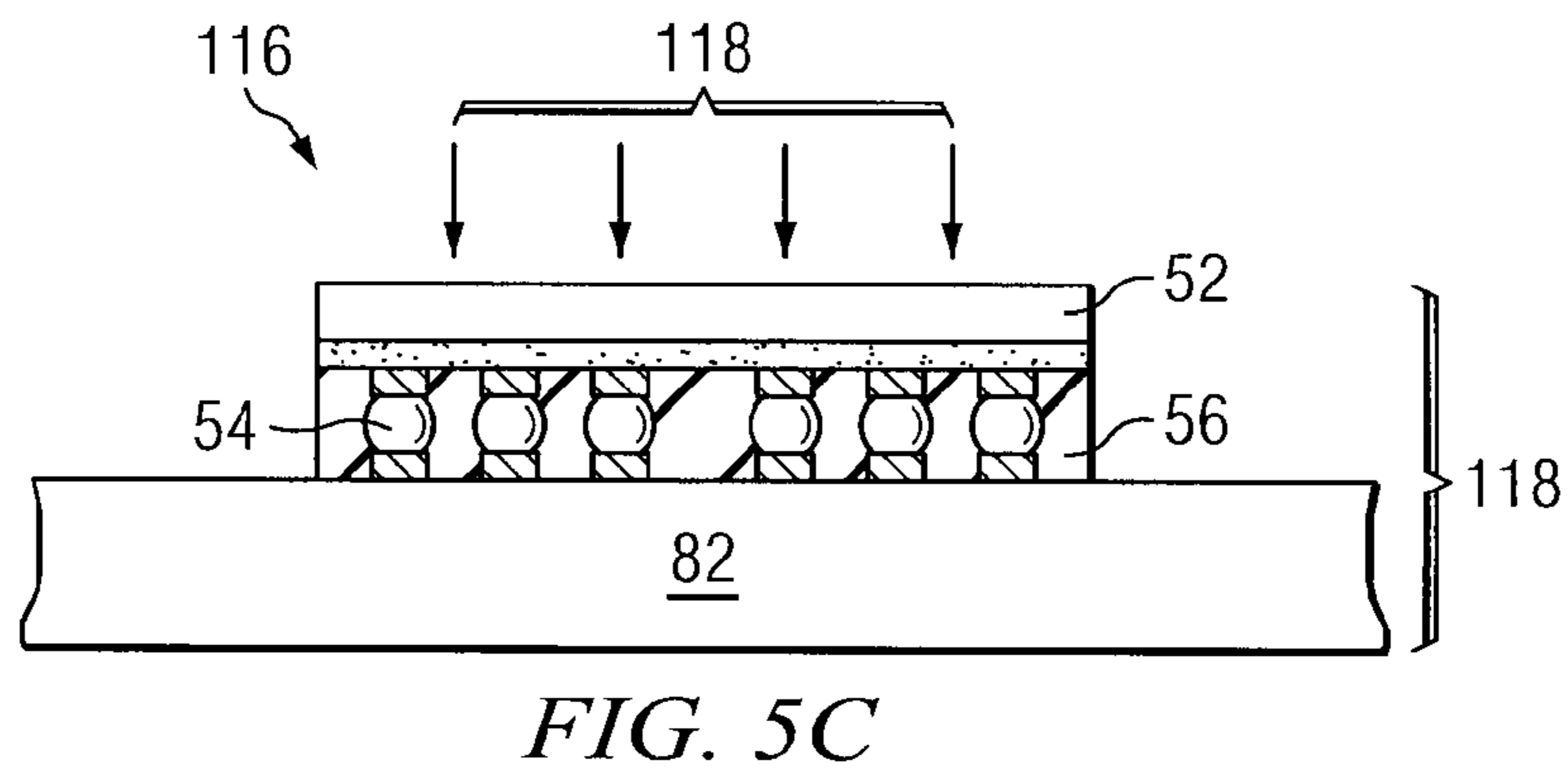
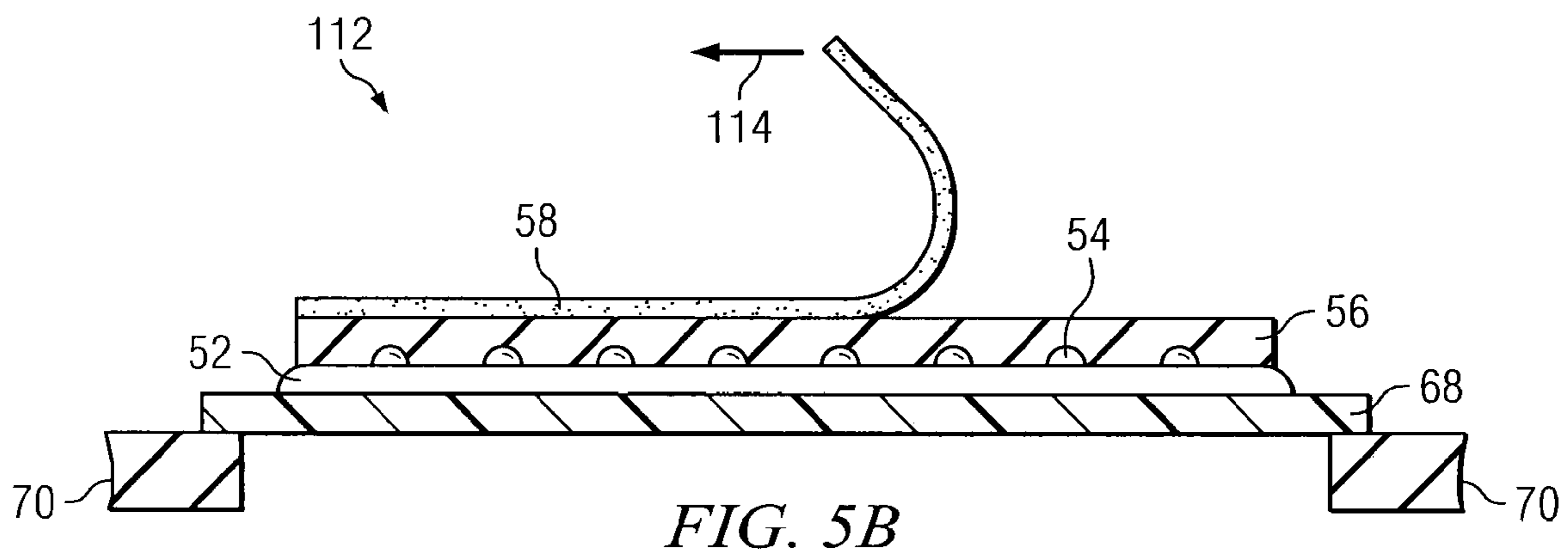
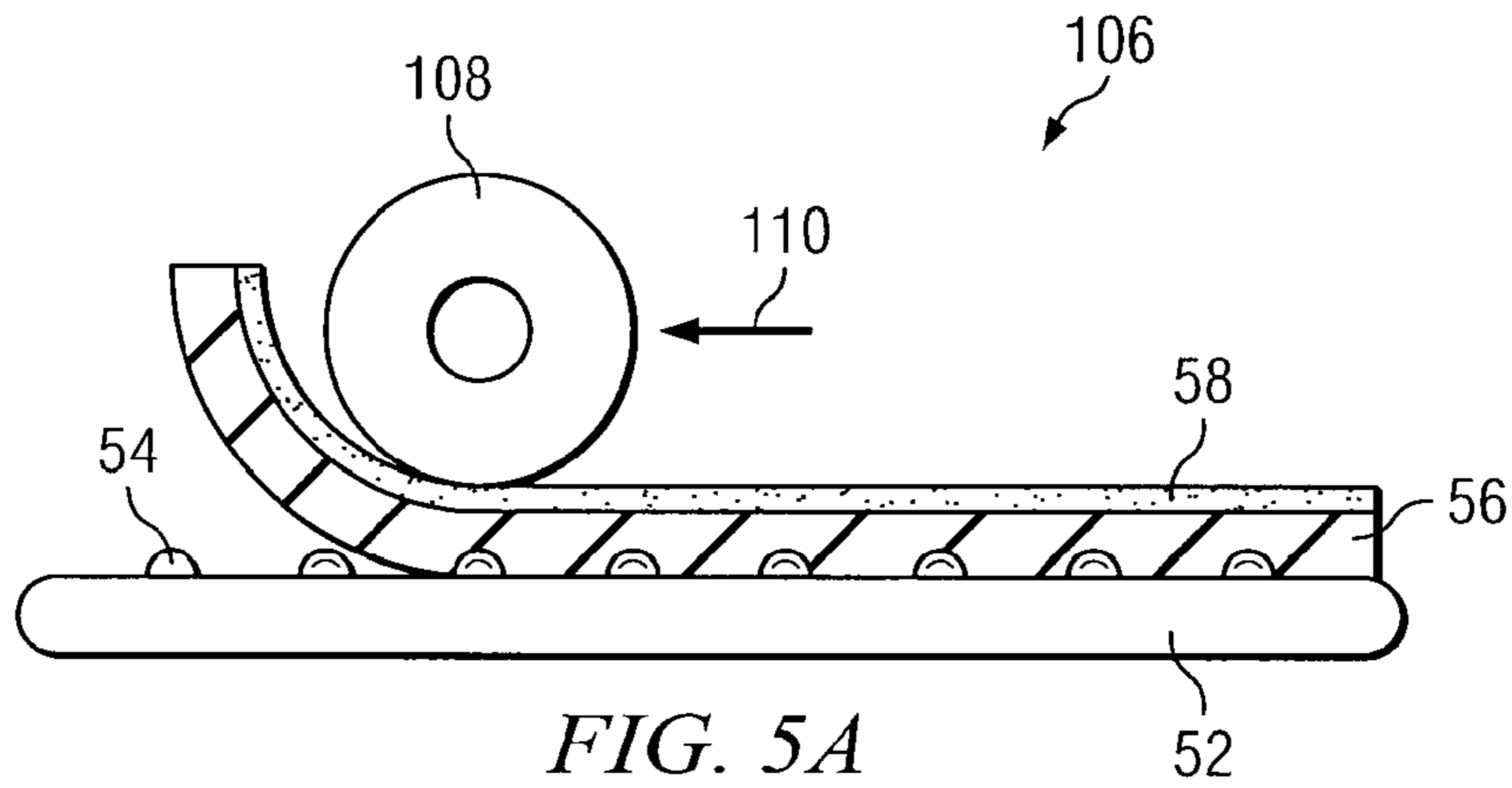

FIG. 2B







ULTRA THIN BUMPED WAFER WITH UNDER-FILM

CLAIM TO DOMESTIC PRIORITY

The present application is a division of U.S. patent application Ser. No. 11/745,045, filed May 7, 2007, now U.S. Pat. No. 7,838,391.

FIELD OF THE INVENTION

The present invention relates in general to electronic devices and, more particularly, to a method of forming a thin bumped wafer semiconductor device having an under-film material and utilizing a support structure during a back grinding process.

BACKGROUND OF THE INVENTION

Semiconductors, or computer chips, are found in virtually every electrical product manufactured today. Chips are used not only in very sophisticated industrial and commercial electronic equipment, but also in many household and consumer items such as televisions, clothes washers and dryers, radios, and telephones. As products become smaller but more functional, there is a need to include more chips in the smaller products to perform the functionality. The reduction in size of cellular telephones is one example of how more and more capabilities are incorporated into smaller and smaller electronic products.

A so-called "flip chip" is generally a monolithic semiconductor device, such as an integrated circuit, having bead-like terminals formed on one surface of the chip. The terminals serve to both secure the chip to a circuit board and electrically connect the flip chip's circuitry to a conductor pattern formed on the circuit board, which may be a ceramic substrate, printed wiring board, flexible circuit, or a silicon substrate. Due to the numerous functions typically performed by the microcircuitry of a flip chip, a relatively large number of terminals are required.

Because of the fine patterns of the terminals and conductor pattern, soldering a flip chip to its conductor pattern requires a significant degree of precision. Reflow solder techniques are widely utilized in the soldering of flip chips. Such techniques typically involve forming solder bumps on the surface of the flip chip using methods such as electrodeposition, by which a quantity of solder is accurately deposited on one surface of the flip chip. Heating the solder above its melting temperature serves to form the characteristic solder bumps. The chip is then soldered to the conductor pattern by registering the solder bumps with their respective conductors, and reheating, or reflowing, the solder so as to metallurgically and electrically bond the chip to the conductor pattern.

In flip chip packaging and other semiconductor devices, a so-called "underfill" material is provided between the substrate and the die to promote device reliability characteristics. Various methods are known in the art for depositing the underfill material, including deposition through an opening of the substrate so as to fill in a gap between the substrate and the die. More recently, techniques involving the application of a film to the bumped wafer have been utilized.

Shortcomings associated with the current art remain. For example, removal of a film material from the bumped wafer can cause damage to the characteristic solder bumps. In addition, the prior art shows a two-step process of attaching a chip

to the substrate, in which case, providing the underfill material results in an extra manufacturing step and the expenditure of excess resources.

SUMMARY OF THE INVENTION

A need exists for an apparatus, method and system which more effectively and precisely controls the underfill application process. In addition, a need exists for an apparatus, method and system which results in a thinner bumped wafer structure, which is increasingly in demand for certain applications.

Accordingly, in one embodiment, the present invention is a semiconductor device comprising a wafer having a plurality of bumps formed on an active surface of the wafer. The semiconductor device further comprises a dicing saw tape laminated to a back surface of the wafer. The active surface of the wafer is opposite the back surface of the wafer. The semiconductor device further comprises an under-film layer contacting the bumps and the active surface of the wafer, and an adhesive layer contacting the under-film layer. The semiconductor device further comprises a removable support layer attached to the adhesive layer, wherein the removable support layer provides structural support to the wafer during a grinding process to remove material from the back surface of the wafer.

In another embodiment, the present invention is a semiconductor device comprising a plurality of substrates having bumps formed on active surfaces of the substrates, and a dicing saw tape laminated to back surfaces of the substrates. The active surfaces of the substrates are opposite the back surfaces of the substrates. The semiconductor device further comprises a plurality of under-film layers, each of the under-film layers contacting the bumps and the active surface of one of the substrates.

In still another embodiment, the present invention is a semiconductor device comprising a wafer, an under-film layer disposed above an active surface of the wafer, an adhesive layer disposed above the under-film layer, and a removable support layer attached to the adhesive layer. The removable support layer provides structural support to the wafer during a grinding process to remove material from a back surface of the wafer. The removable support layer is detached from the adhesive layer at the completion of the grinding process, and the adhesive layer is removed to expose the under-film layer to receive a die.

In still another embodiment, the present invention is a semiconductor device comprising a wafer and a dicing saw tape laminated to a back surface of the wafer. An active surface of the wafer is opposite the back surface of the wafer. The semiconductor device further comprises a lamination tape disposed in contact with the wafer. The lamination tape includes an under-film layer contacting the active surface of the wafer. The lamination tape further includes an adhesive layer contacting the under-film layer.

BRIEF DESCRIPTION OF THE DRAWINGS

FIG. 1 illustrates an exemplary prior art method for providing an underfill material over a bumped wafer structure;

FIG. 2A illustrates a first step in an exemplary method of forming a semiconductor device;

FIG. 2B illustrates a second step in the exemplary method of forming a semiconductor device as shown in FIG. 2A;

FIG. 2C illustrates a third step in the exemplary method of forming a semiconductor device as shown in FIG. 2A;

FIG. 2D illustrates a fourth step in the exemplary method of forming a semiconductor device as shown in FIG. 2A;

FIG. 2E illustrates a fifth and final step in the exemplary method of forming a semiconductor device as shown in FIG. 2A;

FIG. 3 illustrates the structural support of a bumped wafer through the use of a support layer resulting in a thinner bumped wafer;

FIG. 4A illustrates a disadvantage of an exemplary prior art method of peeling adhesive tape from a bumped wafer structure;

FIG. 4B illustrates a two-step exemplary prior art process of attaching a die to a bumped wafer surface, and then performing an underfill process on the attached die and wafer;

FIG. 5A illustrates an exemplary method of tape lamination to the active surface of a bumped wafer structure;

FIG. 5B illustrates an exemplary method of removing an adhesive layer to expose an underfill layer; and

FIG. 5C illustrates a one-step die attaching and underfill process performed to a connected bumped wafer structure/die.

DETAILED DESCRIPTION OF THE DRAWINGS

The present invention is described in one or more embodiments in the following description with reference to the Figures, in which like numerals represent the same or similar elements. While the invention is described in terms of the best mode for achieving the invention's objectives, it will be appreciated by those skilled in the art that it is intended to cover alternatives, modifications, and equivalents as may be included within the spirit and scope of the invention as defined by the appended claims and their equivalents as supported by the following disclosure and drawings.

FIG. 1 illustrates an exemplary prior art method of providing an underfill material over a bumped wafer structure. A film 10 includes layers 11 and 12 which are disposed over an underfill layer 13. A bumped wafer 20 has an active surface 21 and a back surface 22 including a plurality of bumps 23. A roller is used to press film 10 onto the bumped wafer 20 under heating so as to have bumps 23 embedded in the underfill layer 13. The back surface 22 is faced to a grinding tool to thin the thickness of the wafer 20 by grinding the back surface 22 of the wafer 20. The step of grinding the back surface 22 of the wafer occurs following the removal of a heating device.

In contrast to the prior art, the present invention incorporates several innovative changes which allow a thinner bumped wafer structure to be formed without sacrificing bump integrity. Turning to FIG. 2A a first step in an exemplary method of forming a semiconductor device, including a bumped wafer structure, is shown. Device 50 includes a bumped wafer 52, having a plurality of bumps 54. The bumps 54 can include such bumps as solder bumps, gold (Au) bumps, or copper (Cu) bumps, for example. An under-film layer 56 is laminated to the bumped wafer 52, so that the bumps 54 are surrounded by the under-film material 56 as shown. An adhesive layer 58 is deposited against the under-film layer 56. Collectively, the under-film layer 56 and adhesive layer 58 comprise a lamination tape 60.

Lamination tape 60 can be deposited by various means known in the art, such as pressing methods. In one embodiment, the under-film layer 56 can be deposited as a coating over the bumped wafer 52, while the adhesive layer 58 is then laminated over the under-film layer 56. Under-film layer 56 can also be deposited using a spin coating or a screen printing method.

In a departure from the prior art, FIG. 2A depicts a support layer 62 which is coupled to the adhesive layer 58. The support layer 62 provides structural support to the bumped wafer structure 52 while a grinder 64 performs a grinding process against the back surface 65 of the bumped wafer 52 as shown. The bumped wafer is configured as shown so that the support layer 62 is located below layers 60.

The support layer 62 can include such materials as glass, acryl board, wafer, or other hard surfaces which are able to be recycled and are structurally capable of supporting the remainder of the device 50. The support layer 62 is removable. Support layer 62 provides structural support during the grinding process. Support layer 62 allows the bumped wafer 52 to be ground more thinly (i.e., less than 100 um). Conventionally, thicknesses of less than 100 um are generally not achievable without the bumped wafer 52 breaking. Bumped wafer 52 can break because conventional tape material, such as lamination tape, is not sufficient to support the bumped wafer 52 during a back grinding process. Breakage in close proximity to a bump 54 area can occur during back grinding, and can also occur once conventional tape material is removed.

In contrast to conventional techniques, by use of a support layer 62, the respective thickness of the bumped wafer can be made much smaller using a back grinding process. Once the grinding process against the back surface 65 of the bumped wafer 52 is completed, the support layer 62 can be removed.

The adhesive layer 58 can include such materials as ultraviolet (UV) tape, thermoplastic resin, photo-resist, or other materials that have adhesive properties. In many cases, UV tape can be implemented to impart peeling convenience.

FIG. 2B illustrates a second step 66 in the exemplary method of forming a semiconductor device as begun in FIG. 2A. The support layer 62 is shown being removed from the top surface of the adhesive layer 58 following the completion of the grinding process. Device 50 is effectively inverted to place the removable support layer 62 on top of the device structure 66. The layer 62 can then be removed as shown.

A dicing saw tape 68 is laminated to the back surface 65 of the bumped wafer 52. Dicing saw tape 68 can include materials known in the art. Dicing saw tape 68 can support the bumped wafer 52 during a dicing saw process which singulates individual components from the bumped wafer 52. Dicing tape 68 is coupled to a support structure 70 which holds the dicing tape in place during the dicing saw process. Support structure 70 can also include structures and materials which are known in the art. Structure 70 can be compatible with existing tools and manufacturing equipment.

FIG. 2C illustrates a third step 72 in the exemplary method begun in FIG. 2A. The adhesive layer 58 is removed 74 from the under-film layer 56 to expose a top surface 57 of the under-film layer 56. Under-film layer 56 can include such materials as epoxy, or acryl materials having adhesive characteristics.

As a next step, FIG. 2D illustrates the dicing saw process 76 as applied to the bumped wafer 52. A saw 78 singulates the bumped wafer 52, including bumps 54 and under-film material 56, into respective pieces.

FIG. 2E next illustrates the process 80 of die 82 attachment. A series of conductors 54 such as solder balls 54 electrically couple the die 82 to the bumped wafer 52. The under-film layer effectively can become the underfill material between the die 82 and the bumped wafer 52. As a result, the die 82 attachment process and underfill process can proceed as a single step, which saves manufacturing resources and lowers overall cost.

Under-film layer **56** can vary in thickness to suit a particular application. In some cases, the thickness of layer **56** can be so thick as to cause bumps **54** to be covered prior to a die attachment process as shown in FIG. 2E. However, in those cases, a die **82** can be attached to the bumped wafer **52** using a thermal pressure technique. In other cases, the thickness of layer **56** is such as to expose a portion of the bumps **54**.

FIG. 3 conceptually illustrates the importance of the removable support layer **62** in rendering a thinner bumped wafer **52** from a back grinding process. Again, support layer **62** can include a variety of materials, including glass, ceramic, acrylic board, other wafer material, or similar materials. Preferably, the support layer **62** has a high degree of strength and hardness. Additionally, support layer **62** should be smooth throughout, as to impart a level surface for the bumped wafer **52** to reside.

Because support layer **62** is smooth, level, and strong, the physical characteristics of layer **62** plane through to the back surface **86** of bumped wafer **52**. The grind wheel **64** is able to remove material from the back surface **86** with a significant degree of precision and accuracy. Because support layer **62** does not flex like a lamination tape would flex under pressure and stress, the grind wheel **64** can remove additional thickness from bumped wafer **52**.

The grind wheel **64** removes a consistent amount of material throughout the wafer **52**. The back surface **86** of the bumped wafer **52** remains straight and level to a significant degree of precision. No locations of the wafer **52** are substantially thicker than other locations. As a result, a much thinner bumped wafer structure **52** can be achieved than bumped wafers rendered by other conventional methods and techniques. In addition, a technique using a removable support layer **62** as shown results in a consistently repeatable bumped wafer **52** product having high accuracy.

FIG. 4A illustrates shortcomings of a prior art method **88** of peeling adhesive tape **90** from a bumped wafer **94**. As shown, during a tape peeling process, the bumped wafer **94** has a risk of a ball **92** being pulled away from the wafer **94**. In addition to the ball **92** being pulled away from the wafer **94**, the ball **92** may be damaged and prove to be unworkable, as electrical signals do not flow through the ball **92** to an attached die.

Similarly, FIG. 4B illustrates shortcomings of a prior art method **96** of attaching a die **100** to the wafer **94**. In the depicted example, the bumped wafer **94** is pressed (represented by arrows **98**) against the die **100** to attach the die **100** to the bumped wafer **94**. As a following step, an underfill process is undertaken to deposit an underfill material **102** between the bumped wafer **94** and the die **100** as shown. Conventional methods of underfill deposition include such techniques as a needle dispensing process to deposit the underfill material **102** between the die **100** and the bumped wafer **94**.

A two-step process of first attaching a die **100** to a bumped wafer **94**, and second, dispensing an underfill material **102** between the die **100** and the bumped wafer **94** requires additional manufacturing resources, such as additional tools and equipment. Further, a two-step process increases fabrication time and reduces productivity.

FIG. 5A illustrates a film lamination process **106**, in contrast to the techniques and processes of the prior art. Here again, a bumped wafer structure **52** includes a plurality of bumps **54**. An under-film layer **56** and an adhesive layer **58** are collectively laminated over the bumped wafer **52** using a pressing device **108** applying pressure and rotation (denoted by arrow **110**) to the layers **56** and **58** to laminate the layers **56** and **58** to the wafer **52**. As previously mentioned, the under-

film layer **56** can be deposited using a spin coating or screen printing method. The layer **58** can then be laminated over the layer **56**.

The under-film layer **56** can be configured to be thinner than conventional underfill materials, partly because the physical characteristics of a thinner bumped wafer **52** make a thinner underfill possible. Bumped wafer **52** is thinner than a conventional bumped wafer structure, and therefore is lighter and exerts less force on the bumps **54** of the bumped wafer **52**. As one skilled in the art would expect, however, the various physical characteristics of the under-film layer **56** can be varied to suit a particular application, which can correspond to such factors as die size, gap height, bump **54** density, and fillet size.

FIG. 5B illustrates an adhesive layer removal process **112** in contrast to the methods and techniques of the prior art depicted in FIG. 4A. Once the under-film layer **56** and the adhesive layer **58** are laminated to the wafer **52**, the adhesive layer **58** can be removed (denoted by arrow **114**) to expose a top surface of the under-film layer and expose the bumps **54** to receive a die in a later fabrication step. In light of FIG. 5B, the under-film layer **56** functions, in part, to protect the bumps **54** from damage. In addition, the layer **56** functions to provide an underfill material, saving the task of providing underfill material in a later step.

Utilizing an under-film layer **56** as underfill material helps to avoid common shortfalls associated with conventional underfill deposition techniques, including traditional requirements of underfill deposition patterns, issues with underfill overflow, and die damage from needles or other application tools.

In addition, use of an under-film layer **56** helps to alleviate common pitfalls seen in conventional underfill techniques and methods. Such pitfalls include random voiding, voids at an exit location, voids in some units, inconsistent underfill flow, inconsistent filleting, and a large dispense tongue or excessive run-out of underfill material.

FIG. 5C illustrates a one-step process **116** of die attachment and underfill deposition, in contrast to the two-step, prior art method depicted in FIG. 4B. A bumped wafer structure **52** is joined to the die **82** using pressure (denoted by arrows **118**). The under-film layer **56**, which was laminated over the active surface of the bumped wafer **52** in a previous step, now serves as underfill material between the bumped wafer structure **52** and the die **82** as shown for the completed package **118**. Because the under-film layer is preexisting, die **82** attachment and underfill deposition can proceed in a single step.

In addition, conventional underfill material can leave voids or gaps, which can impact device performance and structural stability. The use of under-film layer **56** helps to alleviate the formation of voids, and improves overall device stability and performance.

While one or more embodiments of the present invention have been illustrated in detail, the skilled artisan will appreciate that modifications and adaptations to those embodiments may be made without departing from the scope of the present invention as set forth in the following claims.

What is claimed:

1. A semiconductor device, comprising:
 - a wafer;
 - a conductive material disposed on a first surface of the wafer, the conductive material including a plurality of bumps;
 - a lamination tape disposed over the wafer including,

7

- (a) an under-film layer disposed over the first surface of the wafer and completely covering all of the conductive material disposed on the first surface of the wafer, and
- (b) an adhesive layer disposed over a surface of the under-film layer opposite the wafer;
- a non-flexible support layer disposed over a surface of the lamination tape opposite the wafer for grinding support; a dicing tape disposed on a second surface of the wafer opposite the first surface of the wafer; and
- a support structure, wherein the wafer is disposed over the support structure with the dicing tape contacting the support structure.
2. The semiconductor device of claim 1, wherein the non-flexible support layer includes glass, ceramic, or acryl board.
3. The semiconductor device of claim 1, wherein the adhesive layer includes an ultraviolet (UV) tape.
4. The semiconductor device of claim 1, wherein the under-film layer includes an epoxy or acryl material.
5. A semiconductor device, comprising:
- a substrate;
- a plurality of bumps disposed on a first surface of the substrate;
- an under-film layer disposed over the first surface of the substrate and completely covering the bumps;
- an adhesive layer disposed over a surface of the under-film layer opposite the substrate;
- a non-flexible support layer disposed over a surface of the adhesive layer opposite the substrate for grinding support; and
- a dicing tape disposed on a second surface of the substrate opposite the first surface of the substrate.
6. The semiconductor device of claim 5, wherein the bumps include solder.
7. The semiconductor device of claim 5, wherein the bumps include gold or copper.
8. The semiconductor device of claim 5, wherein the non-flexible support layer includes glass, ceramic, or acryl board.
9. The semiconductor device of claim 5, wherein the adhesive layer includes an ultraviolet (UV) tape.
10. The semiconductor device of claim 5, wherein the under-film layer includes an epoxy or acryl material.
11. A semiconductor device, comprising:
- a wafer including an interconnect structure formed on a first surface of the wafer;
- an under-film layer disposed over the first surface of the wafer and completely covering the interconnect structure;
- an adhesive layer disposed over the under-film layer; and
- a non-flexible support layer disposed over a surface of the adhesive layer opposite the wafer for grinding support.
12. The semiconductor device of claim 11, wherein the wafer includes a plurality of substrates.
13. The semiconductor device of claim 11, wherein the non-flexible support layer includes glass, ceramic, or acryl board.

8

14. The semiconductor device of claim 11, wherein the adhesive layer includes a thermoplastic resin.
15. The semiconductor device of claim 11, wherein the under-film layer includes an acryl adhesive material.
16. The semiconductor device of claim 11, further including a dicing tape disposed on a second surface of the wafer opposite the first surface of the wafer.
17. A semiconductor device, comprising:
- a wafer including a bump formed on a surface of the wafer;
- a flexible lamination tape disposed over the wafer including an under-film layer disposed over the surface of the wafer and an adhesive layer disposed over the under-film layer;
- a rotational pressing device contacting the adhesive layer and applying pressure to the flexible lamination tape to laminate the under-film layer and adhesive layer to the wafer and completely cover the bump; and
- a non-flexible support structure disposed over a surface of the flexible lamination tape opposite the wafer.
18. The semiconductor device of claim 17, further including a dicing tape disposed over the wafer opposite the lamination tape.
19. The semiconductor device of claim 17, wherein the adhesive layer includes an ultraviolet (UV) tape.
20. The semiconductor device of claim 17, wherein the adhesive layer includes a photo-resist material.
21. The semiconductor device of claim 17, wherein the under-film layer includes an acryl adhesive material.
22. The semiconductor device of claim 17, wherein the non-flexible support structure includes glass, ceramic, or acryl board.
23. A semiconductor device, comprising:
- a first substrate including a plurality of interconnect structures formed on a first surface of the first substrate;
- a flexible lamination tape disposed over the first substrate including,
- (a) an under-film layer disposed over the first surface of the first substrate and completely covering the interconnect structures, and
- (b) an adhesive layer disposed over a surface of the under-film layer opposite the first substrate;
- a non-flexible support layer disposed over a surface of the flexible lamination tape opposite the first substrate; and
- a dicing tape disposed over a second surface of the first substrate opposite the first surface of the first substrate.
24. The semiconductor device of claim 23, wherein the non-flexible support layer includes glass, ceramic, or acryl board.
25. The semiconductor device of claim 23, wherein the adhesive layer includes an ultraviolet (UV) tape.
26. The semiconductor device of claim 23, wherein the under-film layer includes an epoxy or acryl material.
27. The semiconductor device of claim 23, further including a second substrate electrically connected to the first substrate through the interconnect structures embedded within the under-film layer.

* * * * *