



US008696538B2

(12) **United States Patent**
Otto

(10) **Patent No.:** **US 8,696,538 B2**
(45) **Date of Patent:** ***Apr. 15, 2014**

(54) **METHODS AND APPARATUS FOR THE PLANNING AND DELIVERY OF RADIATION TREATMENTS**

5,001,344 A 3/1991 Kato et al.
5,027,818 A 7/1991 Bova et al.
5,332,908 A 7/1994 Weidlich
5,442,675 A 8/1995 Swerdloff et al.

(76) Inventor: **Karl Otto**, Seattle, WA (US)

(Continued)

(*) Notice: Subject to any disclaimer, the term of this patent is extended or adjusted under 35 U.S.C. 154(b) by 560 days.

FOREIGN PATENT DOCUMENTS

JP 6-339541 12/1994
JP 2000-317000 11/2000

This patent is subject to a terminal disclaimer.

(Continued)

(21) Appl. No.: **12/986,420**

OTHER PUBLICATIONS

(22) Filed: **Jan. 7, 2011**

Office Action mailed Sep. 18, 2012 in co-pending U.S. Appl. No. 13/043,892, filed Mar. 9, 2011, entitled "Methods and Apparatus for the Planning and Delivery of Radiation Treatments."

(65) **Prior Publication Data**

US 2011/0110492 A1 May 12, 2011

(Continued)

Related U.S. Application Data

(63) Continuation of application No. 12/132,597, filed on Jun. 3, 2008, now Pat. No. 7,880,154, which is a continuation-in-part of application No. 11/996,932, filed as application No. PCT/CA2006/001225 on Jul. 25, 2006, now Pat. No. 7,906,770.

Primary Examiner — Christine Matthews

Assistant Examiner — Joshua D Lannu

(60) Provisional application No. 60/701,974, filed on Jul. 25, 2005.

(74) Attorney, Agent, or Firm — Oyen Wiggs Green & Mutala LLP

(51) **Int. Cl.**
A61N 5/10 (2006.01)

(52) **U.S. Cl.**
USPC **600/2**

(58) **Field of Classification Search**
USPC 600/1, 2
See application file for complete search history.

(57) **ABSTRACT**

Methods and apparatus are provided for planning and delivering radiation treatments by modalities which involve moving a radiation source along a trajectory relative to a subject while delivering radiation to the subject. In some embodiments the radiation source is moved continuously along the trajectory while in some embodiments the radiation source is moved intermittently. Some embodiments involve the optimization of the radiation delivery plan to meet various optimization goals while meeting a number of constraints. For each of a number of control points along a trajectory, a radiation delivery plan may comprise: a set of motion axes parameters, a set of beam shape parameters and a beam intensity.

(56) **References Cited**

U.S. PATENT DOCUMENTS

3,987,281 A * 10/1976 Hodes 600/407
4,868,843 A 9/1989 Nunan
4,868,844 A 9/1989 Nunan

50 Claims, 16 Drawing Sheets

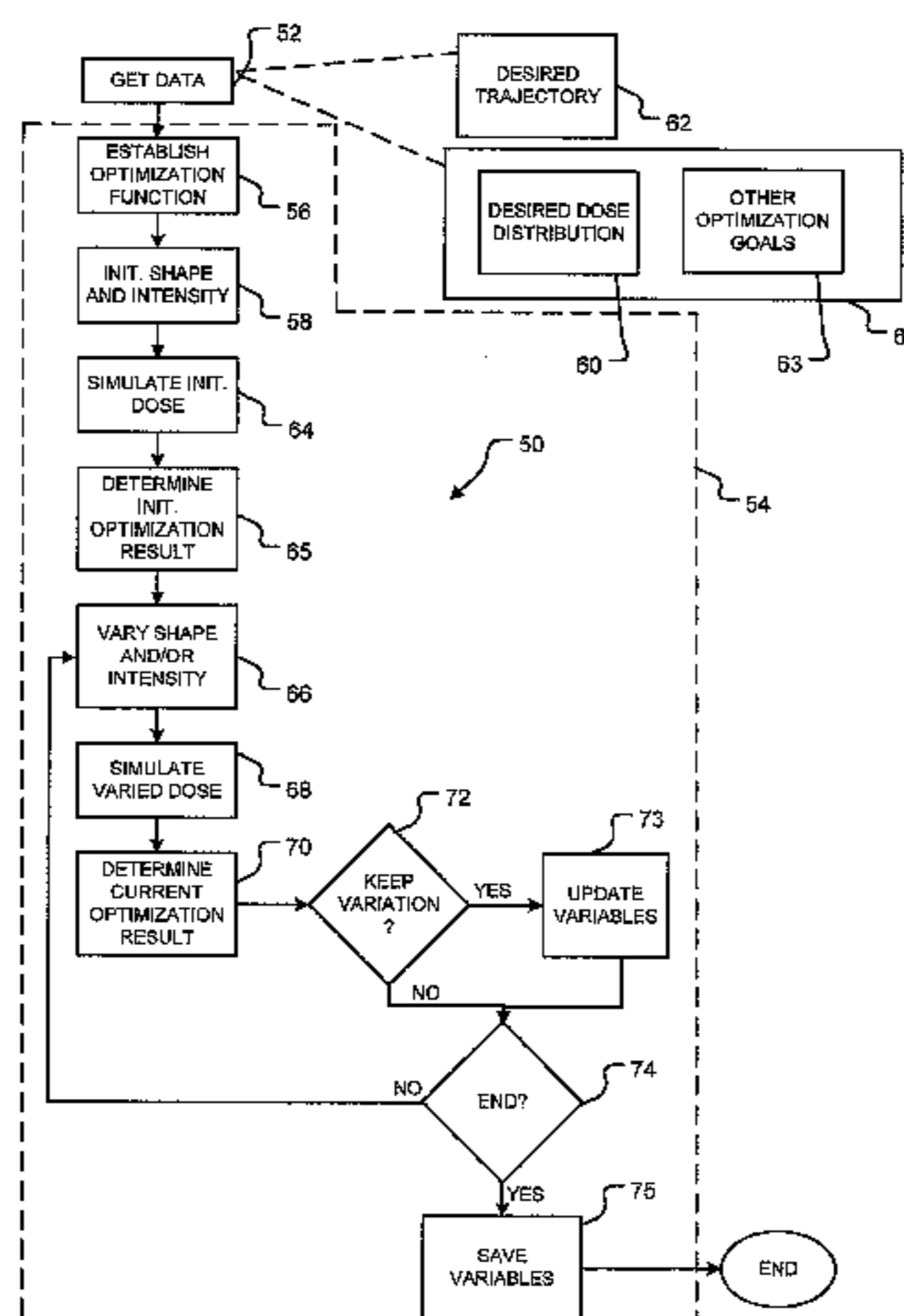

(56)

References Cited

U.S. PATENT DOCUMENTS

5,591,983 A 1/1997 Yao
 5,647,663 A 7/1997 Holmes
 5,663,999 A 9/1997 Siochi
 5,748,703 A 5/1998 Cosman
 5,757,881 A 5/1998 Hughes
 5,802,136 A 9/1998 Carol
 5,818,902 A 10/1998 Yu
 6,038,283 A 3/2000 Carol et al.
 6,052,430 A 4/2000 Siochi et al.
 6,108,400 A 8/2000 Siochi
 6,134,296 A 10/2000 Siochi
 6,142,925 A 11/2000 Siochi et al.
 6,240,161 B1 5/2001 Siochi
 6,260,005 B1 7/2001 Yang et al.
 6,278,766 B1 8/2001 Kooy et al.
 6,314,159 B1 11/2001 Siochi
 6,330,300 B1 12/2001 Siochi
 6,335,961 B1 1/2002 Wofford et al.
 6,349,129 B1 2/2002 Siochi
 6,353,222 B1 3/2002 Dotan
 6,385,286 B1 5/2002 Fitchard et al.
 6,385,477 B1 5/2002 Werner et al.
 6,393,096 B1 5/2002 Carol et al.
 6,473,490 B1 10/2002 Siochi
 6,504,899 B2 1/2003 Pugachev et al.
 6,560,311 B1 5/2003 Shepard et al.
 6,661,870 B2 12/2003 Kapatoes et al.
 6,735,277 B2 5/2004 McNutt et al.
 6,757,355 B1 6/2004 Siochi
 6,792,074 B2 9/2004 Erbel et al.
 6,850,252 B1 2/2005 Hoffberg
 6,852,974 B2 2/2005 Kochi et al.
 6,853,705 B2 2/2005 Chang
 6,882,702 B2 4/2005 Luo
 6,907,105 B2 6/2005 Otto
 7,046,762 B2 5/2006 Lee
 7,085,348 B2 8/2006 Kamath et al.
 7,151,258 B2 12/2006 Kochi et al.
 7,162,008 B2 1/2007 Earl et al.
 7,329,867 B2 2/2008 Kochi et al.
 7,333,591 B2 2/2008 Earl et al.
 7,352,370 B2 4/2008 Wang et al.
 7,369,645 B2 5/2008 Lane
 7,525,090 B1 4/2009 Krzeczowski
 7,556,596 B2 7/2009 Mourtada et al.
 7,693,683 B2 4/2010 Ihara
 7,755,043 B1 7/2010 Gubbens
 7,813,822 B1 10/2010 Hoffberg
 7,831,289 B2 11/2010 Riker et al.
 7,872,236 B2 1/2011 Zhang
 7,907,987 B2 3/2011 Dempsey
 2002/0006182 A1 1/2002 Kim et al.
 2002/0179812 A1 12/2002 Kochi et al.
 2003/0086530 A1* 5/2003 Otto 378/65
 2003/0212325 A1 11/2003 Cotruz et al.
 2003/0219098 A1 11/2003 McNutt et al.
 2004/0001569 A1 1/2004 Luo
 2004/0071261 A1 4/2004 Earl et al.
 2004/0190680 A1 9/2004 Chang
 2004/0254448 A1 12/2004 Amies et al.
 2005/0040332 A1 2/2005 Kochi et al.
 2005/0061972 A1 3/2005 Kochi et al.
 2005/0096515 A1 5/2005 Geng
 2005/0111621 A1 5/2005 Riker et al.
 2005/0197564 A1 9/2005 Dempsey
 2006/0060780 A1 3/2006 Masnaghetti et al.
 2006/0176295 A1 8/2006 Toho et al.
 2006/0235260 A1 10/2006 Mourtada et al.
 2006/0256915 A1 11/2006 Otto et al.
 2006/0274061 A1 12/2006 Wang et al.
 2006/0274925 A1 12/2006 West et al.
 2006/0289757 A1 12/2006 Kochi et al.
 2007/0220108 A1 9/2007 Whitaker
 2007/0221842 A1 9/2007 Morokuma et al.
 2007/0230770 A1 10/2007 Kulkarni et al.

2007/0242797 A1 10/2007 Stewart et al.
 2008/0114564 A1 5/2008 Ihara
 2008/0226030 A1 9/2008 Otto
 2008/0298550 A1 12/2008 Otto
 2008/0317330 A1 12/2008 Takeda et al.
 2009/0161827 A1 6/2009 Gertner et al.
 2009/0230304 A1 9/2009 Hatano et al.
 2009/0297019 A1 12/2009 Zafar et al.
 2009/0322973 A1 12/2009 Ito et al.
 2010/0020931 A1 1/2010 Otto et al.
 2011/0012911 A1 1/2011 Nakamura et al.

FOREIGN PATENT DOCUMENTS

JP 2001-120528 5/2001
 JP 2001-29491 8/2002
 JP 2004-97646 4/2004
 JP 6-79006 3/2006
 WO 9948558 9/1999
 WO 0015299 3/2000
 WO 0160236 8/2001
 WO 0224277 3/2002
 WO 03099380 12/2003
 WO 2005057738 6/2005

OTHER PUBLICATIONS

Bortfeld et al., "Clinically relevant intensity modulation optimization using physical criteria," In Proceedings of the XII International Conference on the Use of Computers in Radiation Therapy, Salt Lake City, Utah, 1-4 (1997).
 Yan, D. et al., "Computed tomography guided management of interfractional patient variation", Semin. Radiat. Oncol. 15, 168-179 (2005).
 Court, L. et al., "An automatic CT-guided adaptive radiation therapy technique by on-line modification of MLC leaf positions for prostate cancer", Int. J. Radiat. Oncol., Biol., Phys. 62(1), 154-163 (2005).
 Mohan, R. et al., "Use of deformed intensity distributions for on-line modification of image-guided IMRT to account for interfractional anatomic changes", Int. J. Radiat. Oncol., Biol., Phys. 61(4), 1258-1266 (2005).
 Mackie, T.R. et al., "Image guidance for precise conformal radiotherapy", Int. J. Radiat. Oncol., Biol., Phys. 56(1), 89-105 (2003).
 Brock, K.K. et al., "Feasibility of a novel deformable image registration technique to facilitate classification, targeting, and monitoring of tumor and normal tissue", Int. J. Radiat. Oncol., Biol., Phys. 64(4), 1245-1254 (2006).
 Davis, B.C. et al., "Automatic segmentation of intra-treatment CT images for adaptive radiation therapy of the prostate", Med. Image Comput. Assist. Interv. Int. Conf. Med. Image. Comput. Assist. Interv. 8(Pt 1), 442-450 (2005).
 Foskey, M., "Large deformation three-dimensional image registration in image-guided radiation therapy", Phys. Med. Biol. 50(24), 5869-5892 (Dec. 7, 2005).
 Munbodh, R. et al., "Automated 2D-3D registration of a radiograph and a cone beam CT using line-segment enhancement", Med. Phys. 33(5), 1398-1411 (Apr. 27, 2006).
 Court, L.E. et al., "Automatic online adaptive radiation therapy techniques for targets with significant shape change: a feasibility study", Phys. Med. Biol. 51(10), 2493-2501 (Apr. 27, 2006).
 Godfrey, D.J. et al., "Digital tomosynthesis with an on-board kilovoltage imaging device", Int. J. Radiat. Oncol., Biol., Phys. 65(1), 8-15 (2006).
 Mestrovic, A. et al., "Direct aperture optimization for online adaptive radiation therapy", Med. Phys. 34(5), Apr. 19, 2007.
 Cotruz, C. et al., "Segment-based dose optimization using a genetic algorithm", Phys. Med. Biol. 48(18), 2987-2998 (2003).
 Bedford, J.L. et al., "Constrained segment shapes in direct-aperture optimization for step-and shoot IMRT", Med. Phys. 33(4), 944-958 (Mar. 17, 2006).
 Kirkpatrick, S. et al., "Optimization by simulated annealing", Science 220, 671-680 (1983).
 I.M.R.T.C.W. Group, "Intensity-modulated radiotherapy: Current status and issues of interest", Int. J. Radiat. Oncol., Biol., Phys. 51(4), 880-914 (2001).

(56)

References Cited

OTHER PUBLICATIONS

- Niemierko, A. et al., "Random sampling for evaluation treatment plans", *Med. Phys.* 17(5), 753-762 (1990).
- Chui, C.S. et al., "Dose calculation for photon beams with intensity modulation generated by dynamic jaw or multileaf collimations", *Med. Phys.* 21(8), 1237-1244 (1994).
- Ghilezan, M.J. et al., "Prostate gland motion assessed with cine-magnetic resonance imaging (cine-MRI)", *Int. J. Radiat. Oncol., Biol., Phys.* 62(2), 406-417 (2005).
- Nichol, A.M. et al., "Intra-prostatic fiducial markers and concurrent androgen deprivation", *Clin. Oncol. (R Coll. Radiol)* 17(6), 465-468 (2005).
- Zellars, R.C. et al., "Prostate position late in the course of external beam therapy: Patterns and predictors", *Int. J. Radiat. Oncol., Biol., Phys.* 47(3), 655-660 (2000).
- Sanguineti, G. et al., "Neoadjuvant androgen deprivation and prostate gland shrinkage during conformal radiotherapy", *Radiother. Oncol.* 66(2), 151-157 (2003).
- Nichol, A.M. et al., "A magnetic resonance imaging study of prostate deformation relative to implanted gold fiducial markers", *Int. J. Radiat. Oncol., Biol., Phys.* 67(1), 48-56 (2007).
- R.T.O.G. 0415, "A Phase III Randomized Study of Hypofractionated 3D-CRT/IMRT Versus Conventionally Fractionated 3D-CRT/IMRT in patients with favourable-risk prostate cancer", (www.RTOG.org accessed on Jul. 2006) (2006).
- Yan, D. et al., "The influence of interpatient and inpatient rectum variation on external beam treatment of prostate cancer", *Int. J. Radiat. Oncol., Biol., Phys.* 51(4), 1111-1119 (2001).
- Hoogeman, M.S. et al., "A model to simulate day-to-day variations in rectum shape", *Int. J. Radiat. Oncol., Biol., Phys.* 54(2), 615-625 (2002).
- Jiang, Z. et al., "An examination of the number of required apertures for step-and-shoot- IMRT", *Phys. Med. Biol.* 50 (23), 5653-5663 (Nov. 24, 2005).
- Earl et al., "Inverse Planning for Intensity-Modulated Arc Therapy Using Direct Aperture Optimization", *Physics in Medicine and Biology* 48 (2003), Institute of Physics Publishing, pp. 1075-1089.
- Spirou et al., "A Gradient Inverse Planning Algorithm with Dose-Volume Constraints", *Med. Phys.* 25, pp. 321-333 (1998).
- Wu et al., "Algorithm and Functionality of an Intensity Modulated Radiotherapy Optimization System", *Med. Phys.* 27, pp. 701-711 (2000).
- Spirou et al., "Generation of Arbitrary Intensity Profiles by Dynamic Jaws or Multileaf Collimators", *Med. Phys.* 21, pp. 1031-1041 (1994).
- Xia et al., "Multileaf Collimator Leaf Sequencing Algorithm for Intensity Modulated Beams with Multiple Static Segments", *Med. Phys.* 25, pp. 1424-1434 (1998).
- Otto et al., "Enhancement of IMRT Delivery through MLC Rotation", *Phys. Med. Biol.* 47, 3997-4017 (2002).
- Shepard et al., "Direct Aperture Optimization: A Turnkey Solution for Step-and-Shoot IMRT", *Med. Phys.* 29 (6) (2002), pp. 1007-1018.
- Tervo et al., "A Model for the Control of a Multileaf Collimator in Radiation Therapy Treatment Planning", *Inverse Problems* 16 (2000), pp. 1875-1895.
- Shepard et al., "An Arc-Sequencing Algorithm for Intensity Modulated Arc Therapy", *Med. Phys.* 34 (2) (2007), pp. 464-470.
- Cao et al., "Continuous Intensity Map Optimization (CIMO): A Novel Approach to Leaf Sequencing in Step and Shoot IMRT", *Med. Phys.* 33 (4) (2006), pp. 859-867.
- Ulrich et al., "Development of an Optimization Concept for Arc-Modulated Cone Beam Therapy", *Phys. Med. Biol.* 52 (2007), pp. 4099-4119.
- Hardemark et al., Direct Machine Parameter Optimization with RayMachine in Pinnacle, RaySearch White Paper, RaySearch Laboratories (2003).
- C. X. Yu, "Intensity-modulated arc therapy with dynamic multileaf collimation: An alternative to tomotherapy," *Phys. Med. Biol.* 40, 1435-1449 1995.
- A. Gladwish et al., "Segmentation and leaf sequencing for intensity modulated arc therapy," *Med. Phys.* 34, 1779-1788 2007.
- E. Wong, J. Z. Chen, and J. Greenland, "Intensity-modulated arc therapy simplified," *Int. J. Radiat. Oncol. Biol. Phys.* 53, 222-235 2002.
- K. Bratengeier, "2-Step IMAT and 2-Step IMRT in three dimensions," *Med. Phys.* 32, 3849-3861 2005.
- C. Cameron, "Sweeping-window arc therapy: An implementation of rotational IMRT with automatic beam-weight calculation," *Phys. Med. Biol.* 50, 4317-4336 2005.
- S. M. Crooks et al., "Aperture modulated arc therapy," *Phys. Med. Biol.* 48, 1333-1344 2003.
- W. De Gersem et al., "Leaf position optimization for step-and-shoot IMRT," *Int. J. Radiat. Oncol. Biol. Phys.* 51, 1371-1388 2001.
- M.-P. Milette and K. Otto, "Maximizing the potential of direct aperture optimization through collimator rotation," *Med. Phys.* 34, 1431-1438 2007.

* cited by examiner

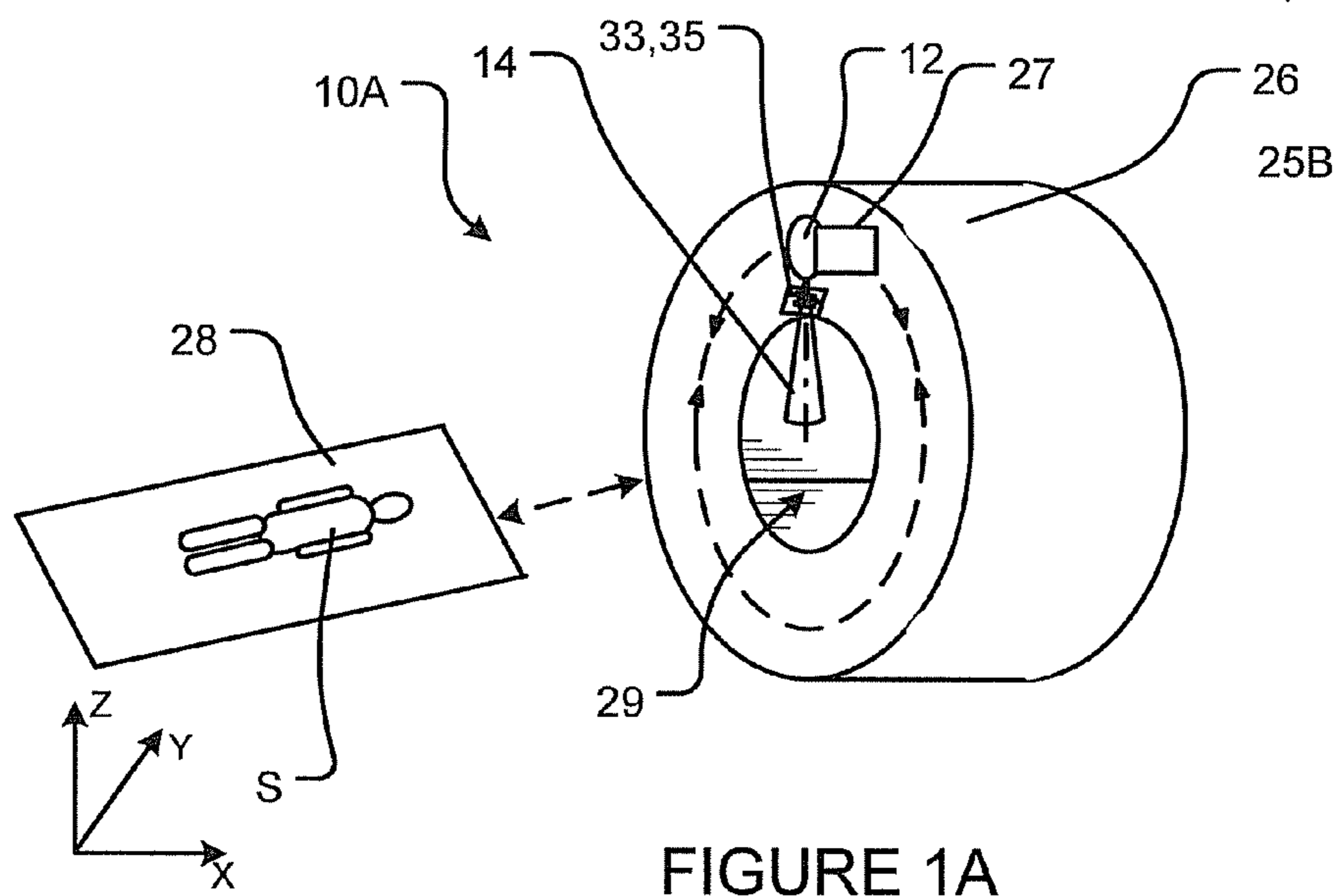
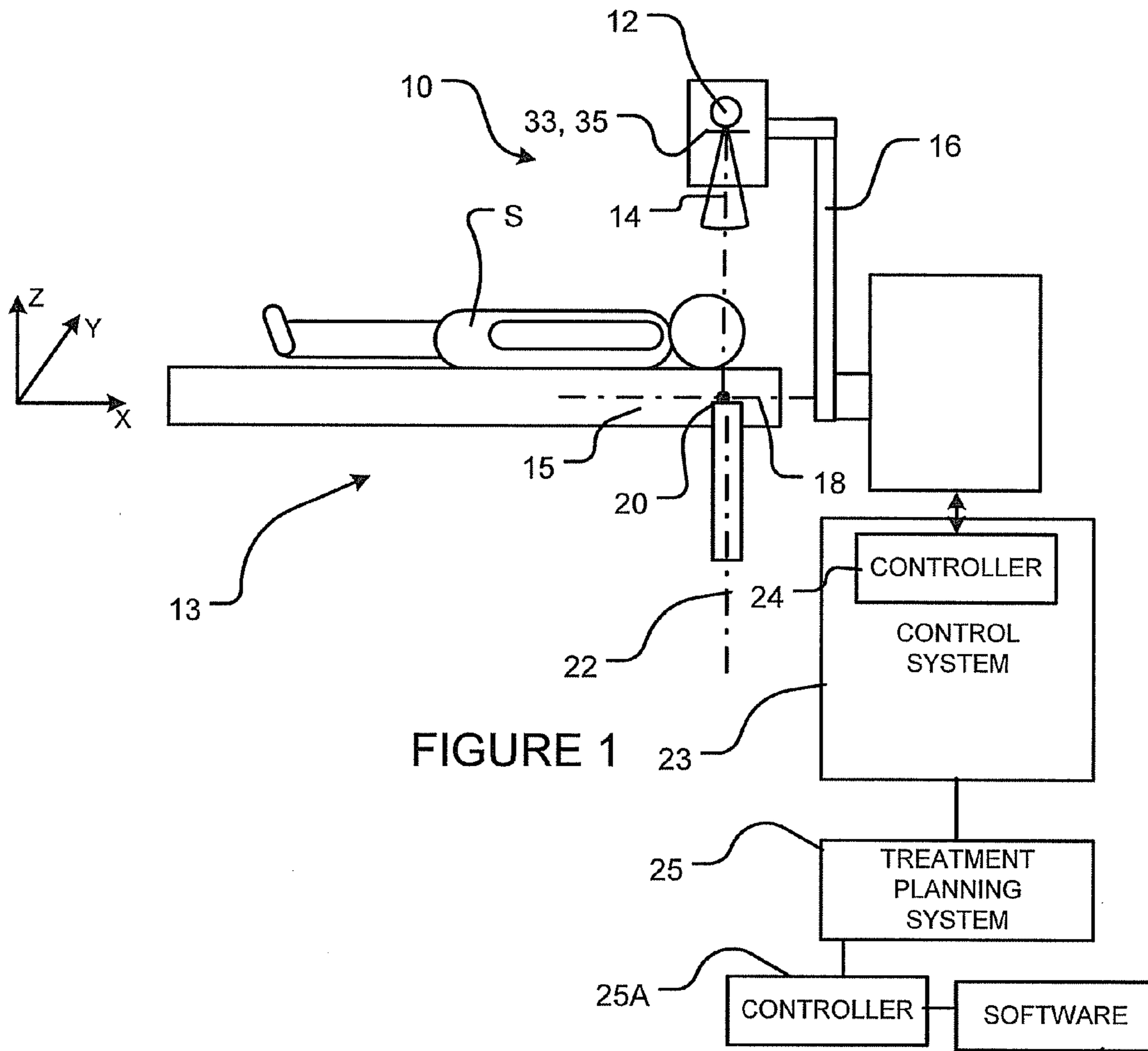

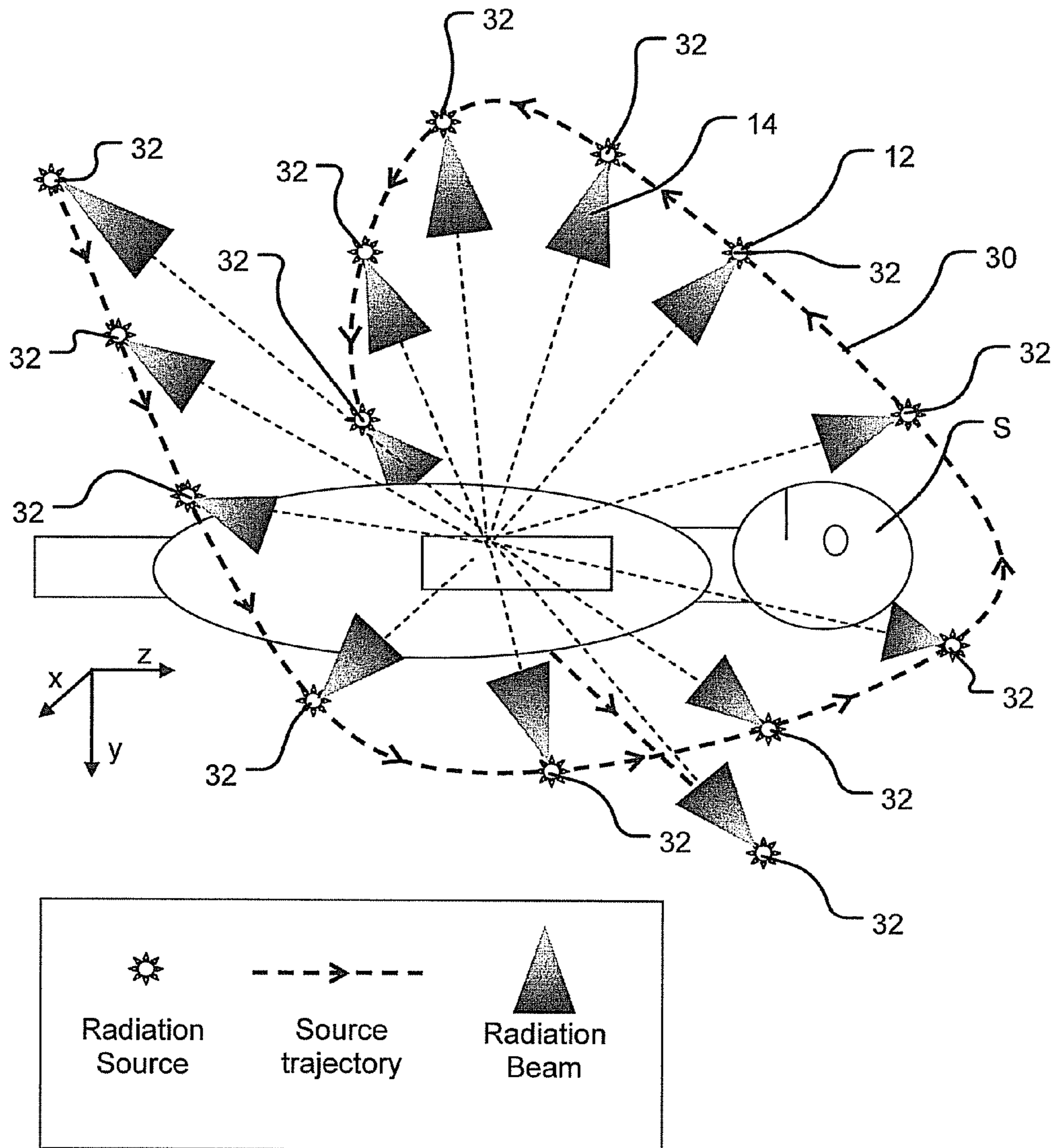

FIGURE 2

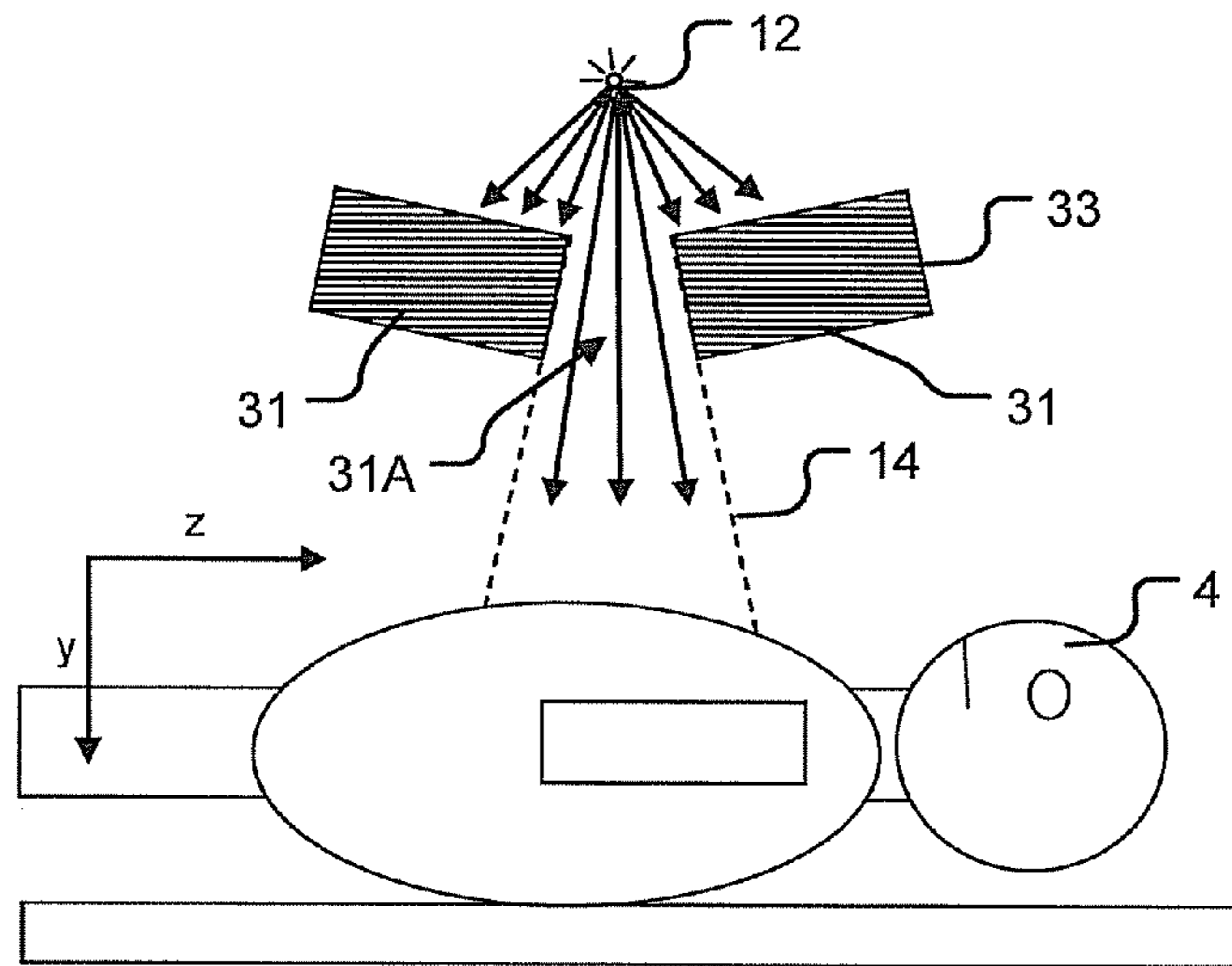

FIGURE 3A

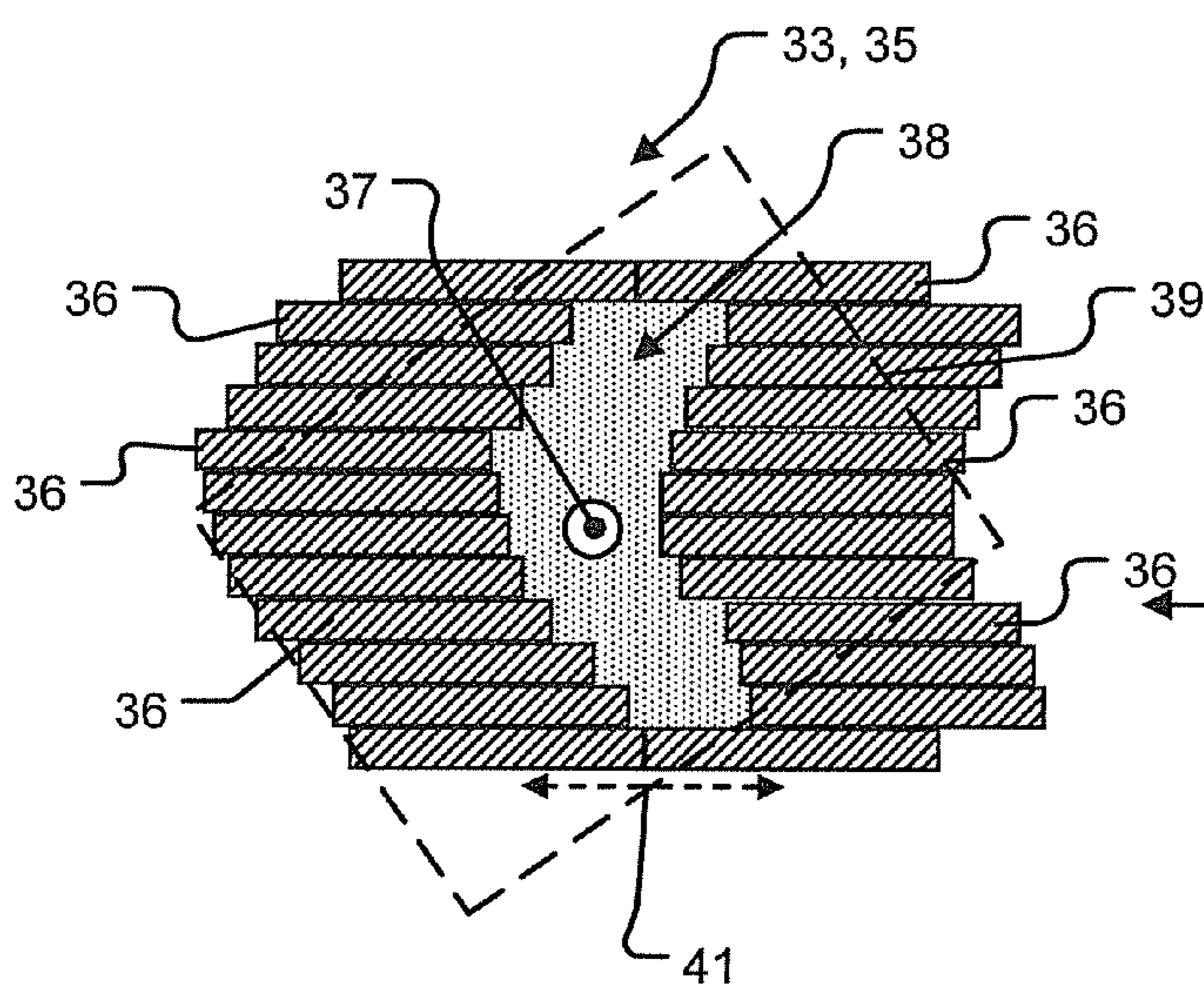

FIGURE 3B

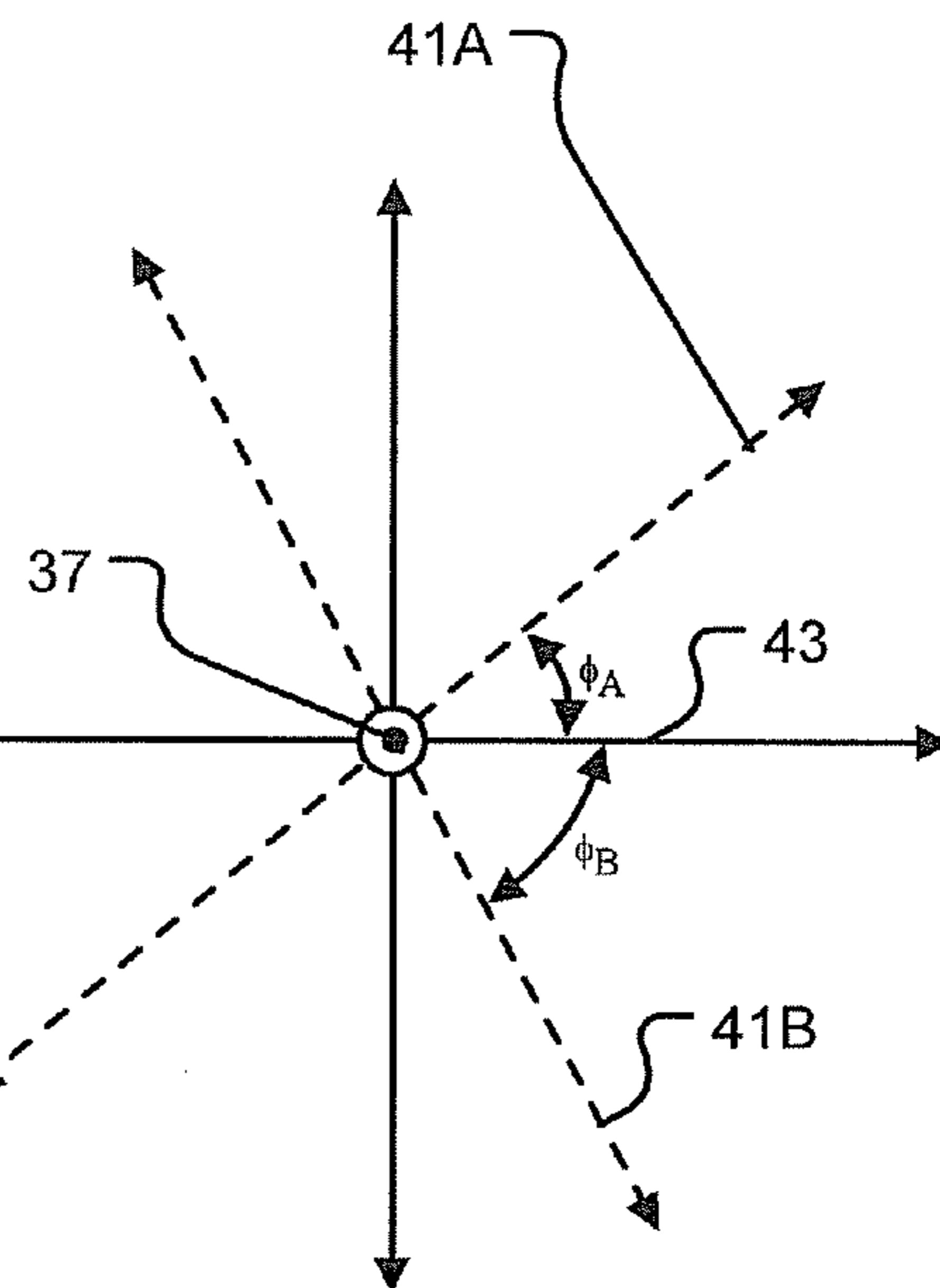

FIGURE 3C

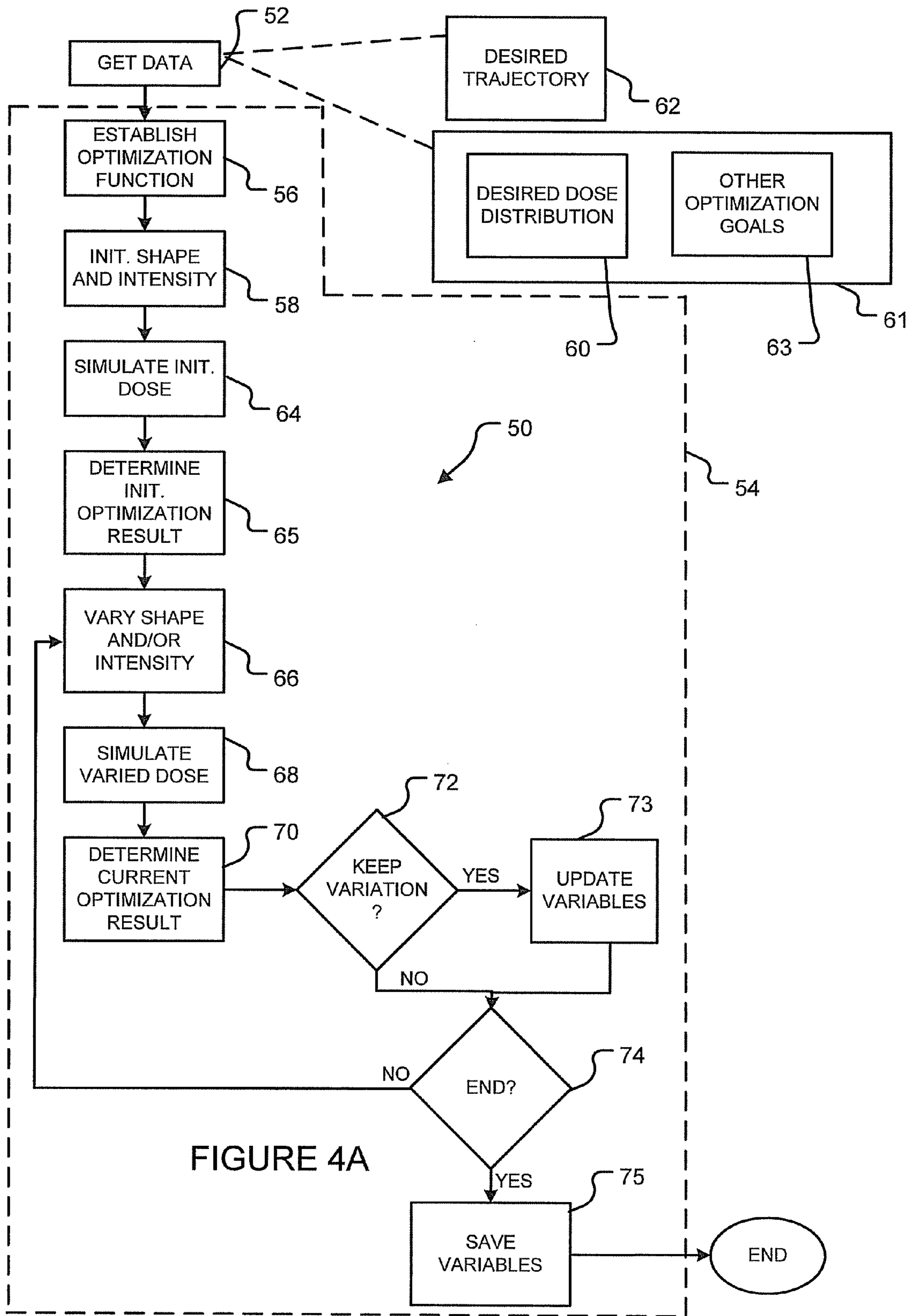

FIGURE 4A

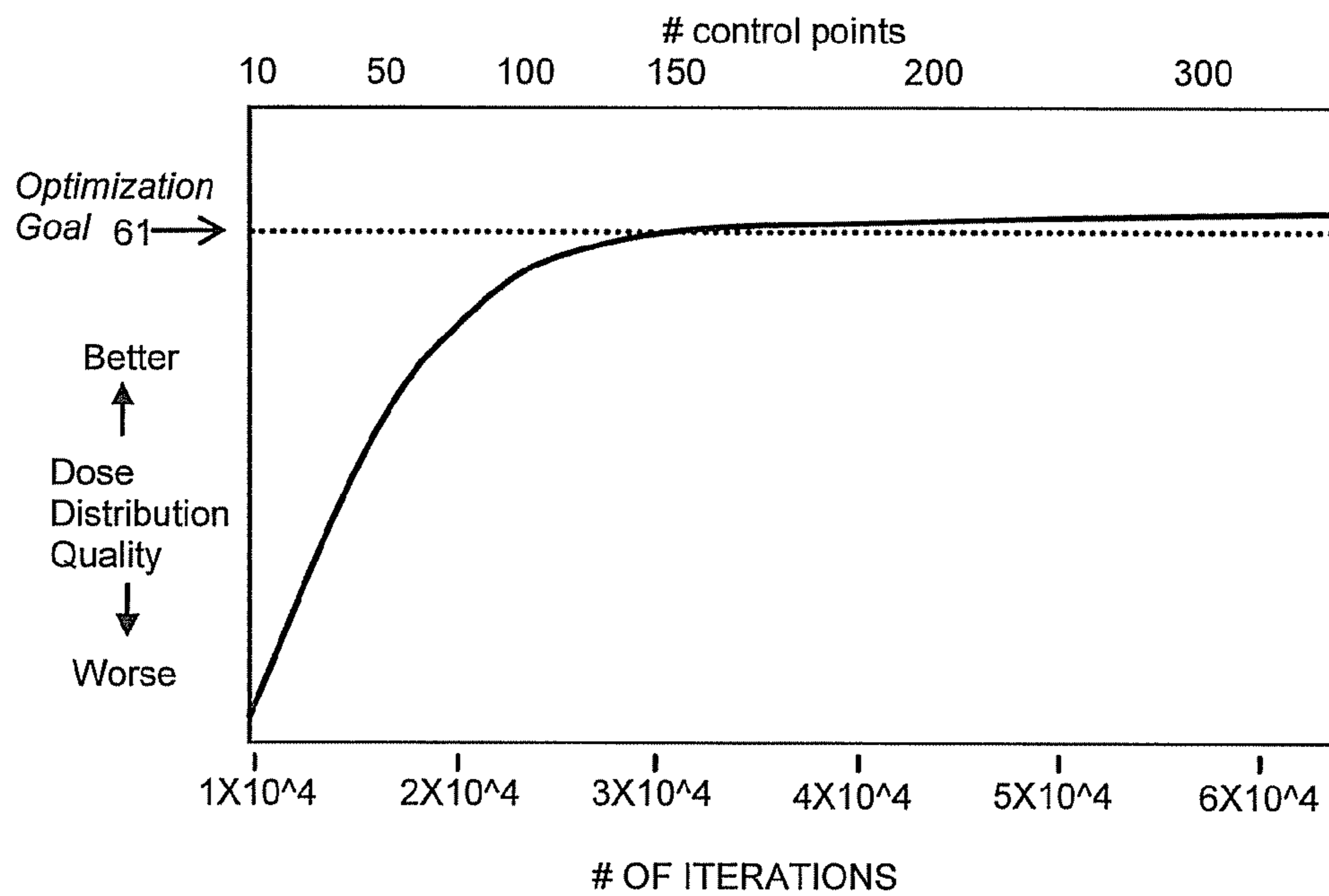

FIGURE 9

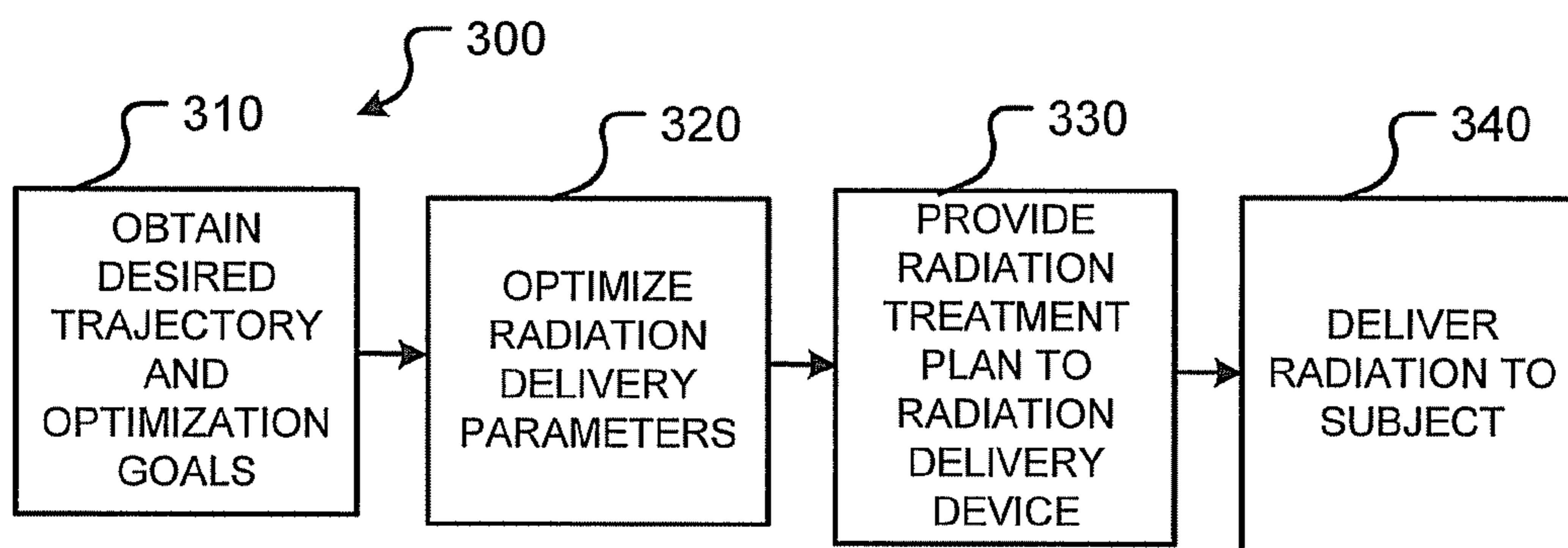

FIGURE 4B

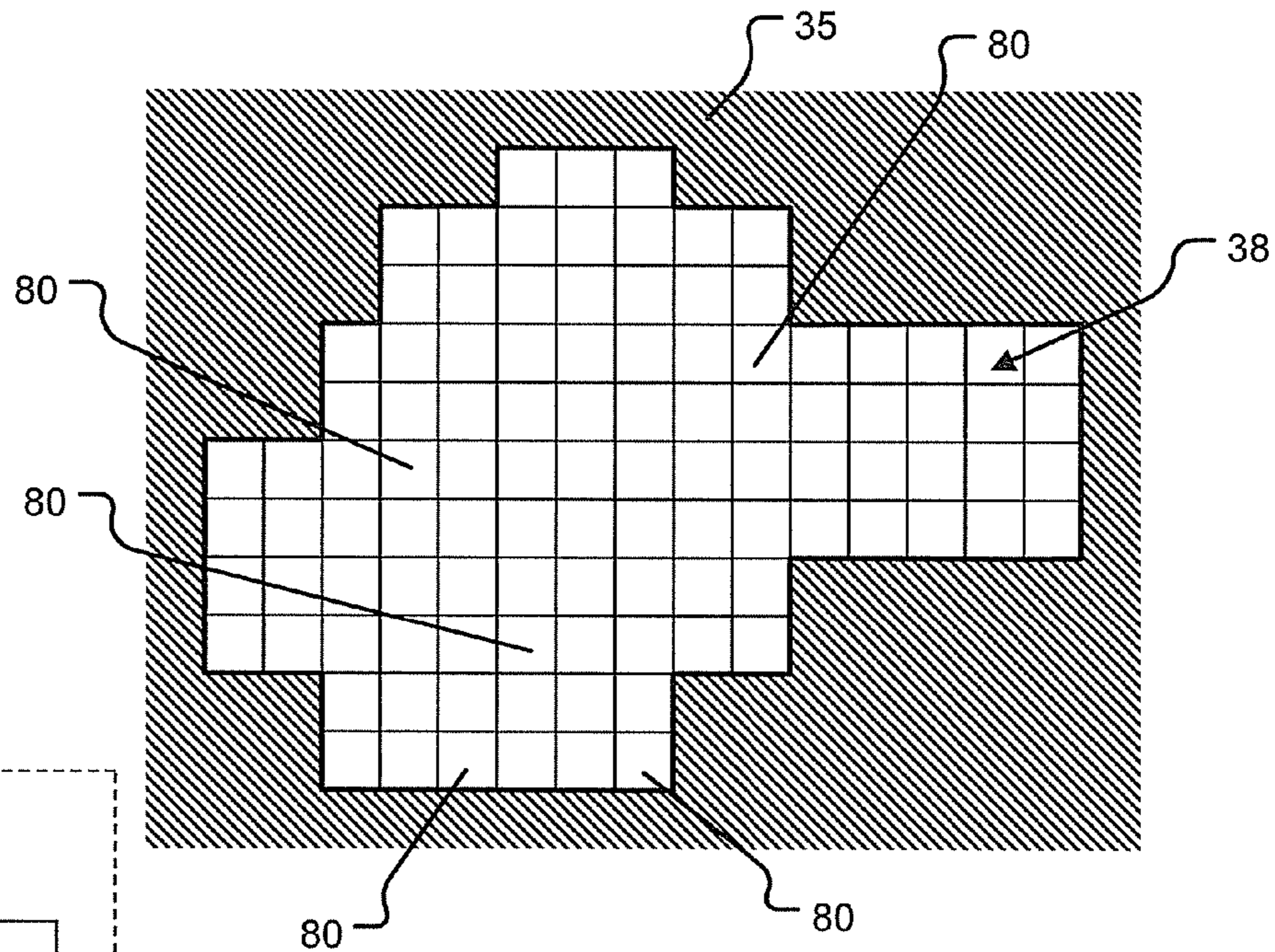

FIGURE 5A

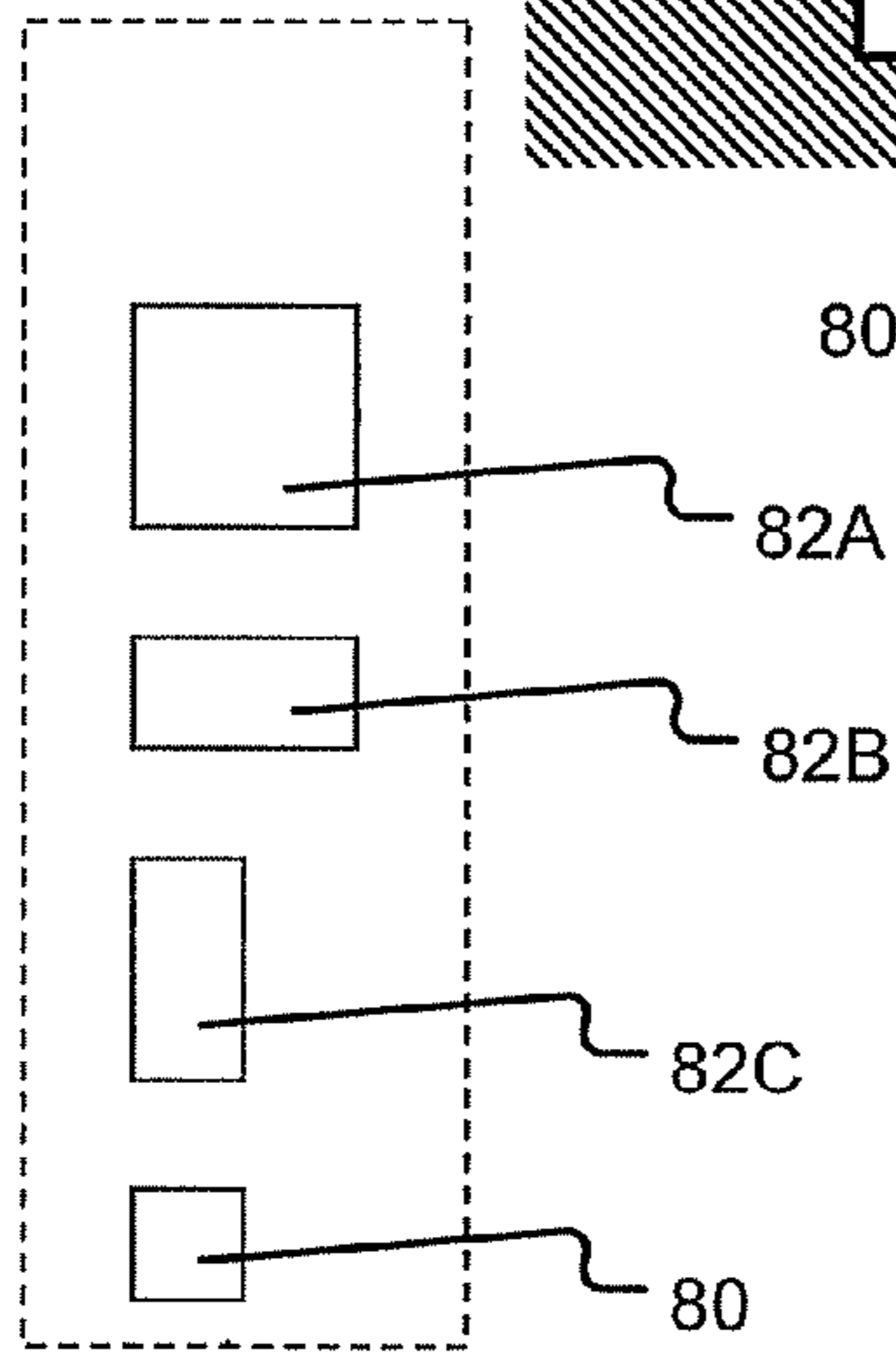

FIGURE 5B

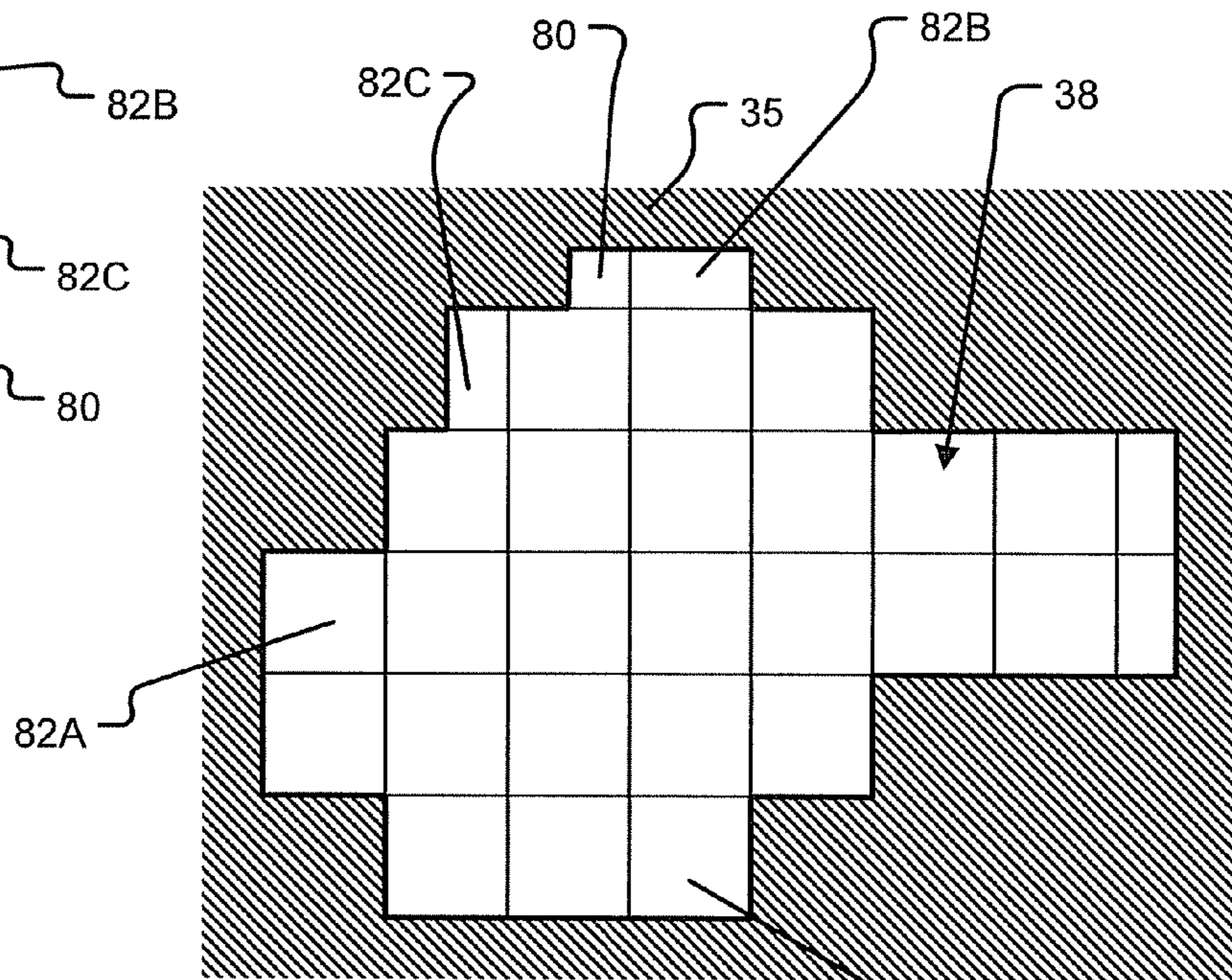

FIGURE 5C

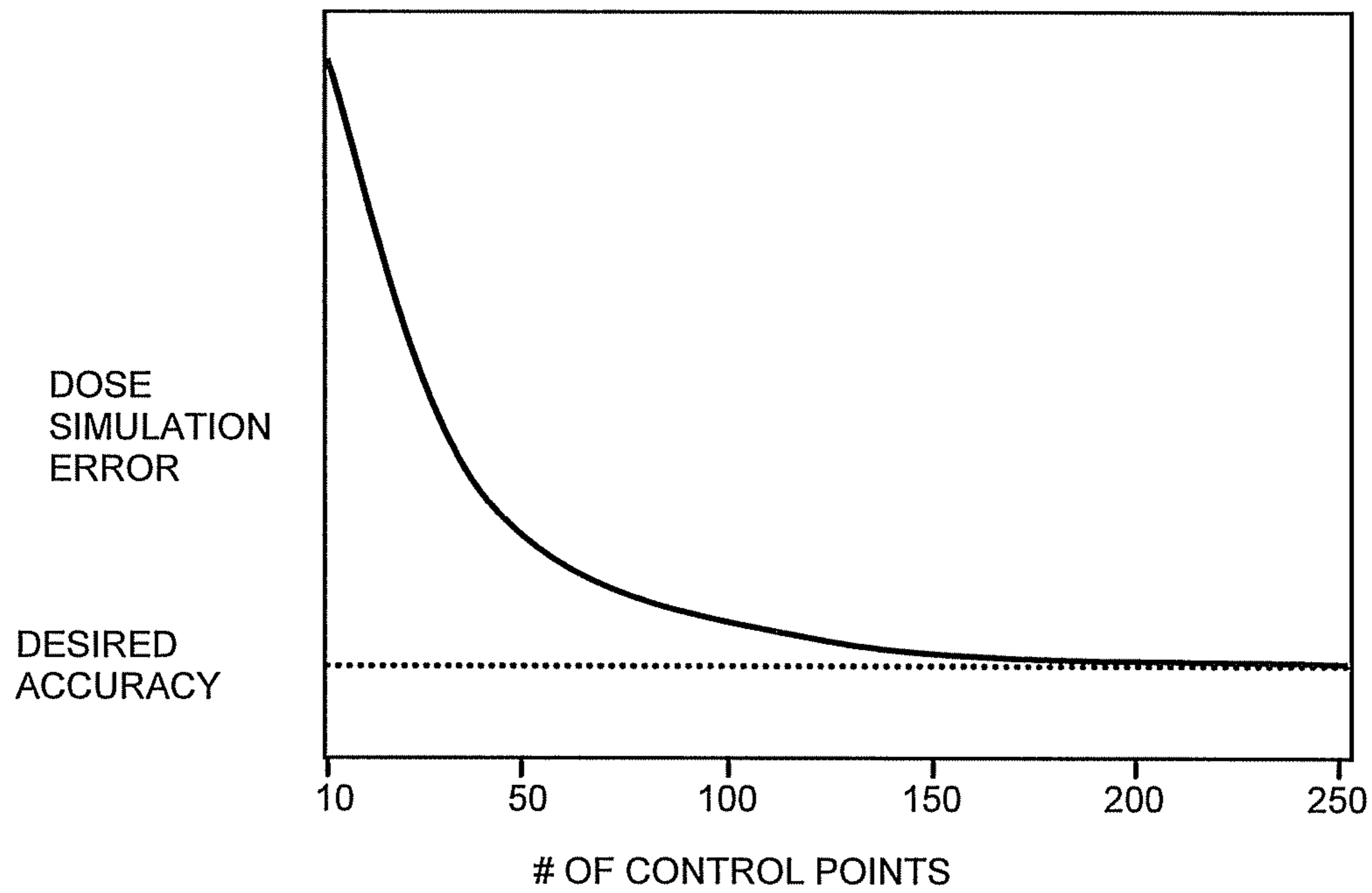

FIGURE 6

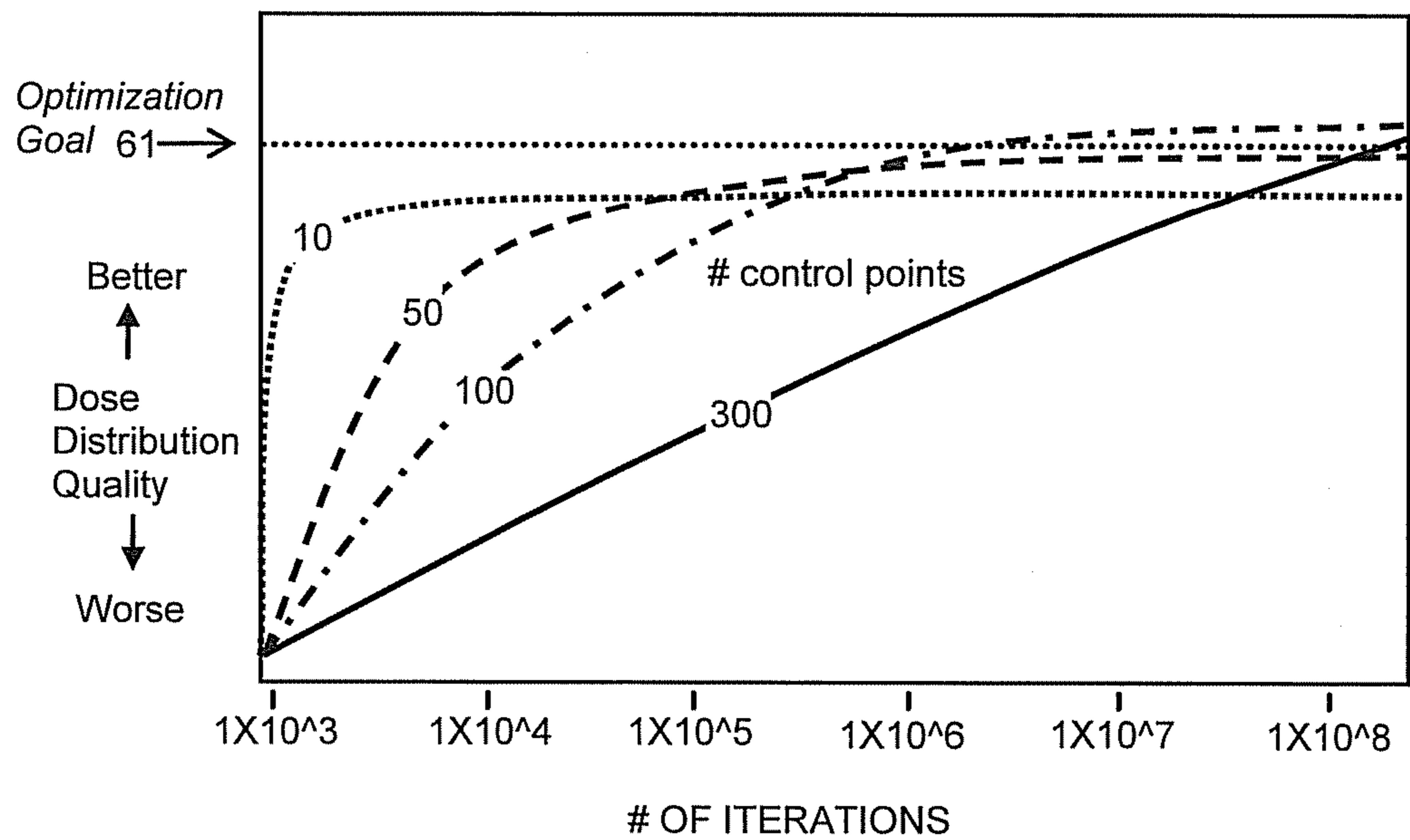

FIGURE 7

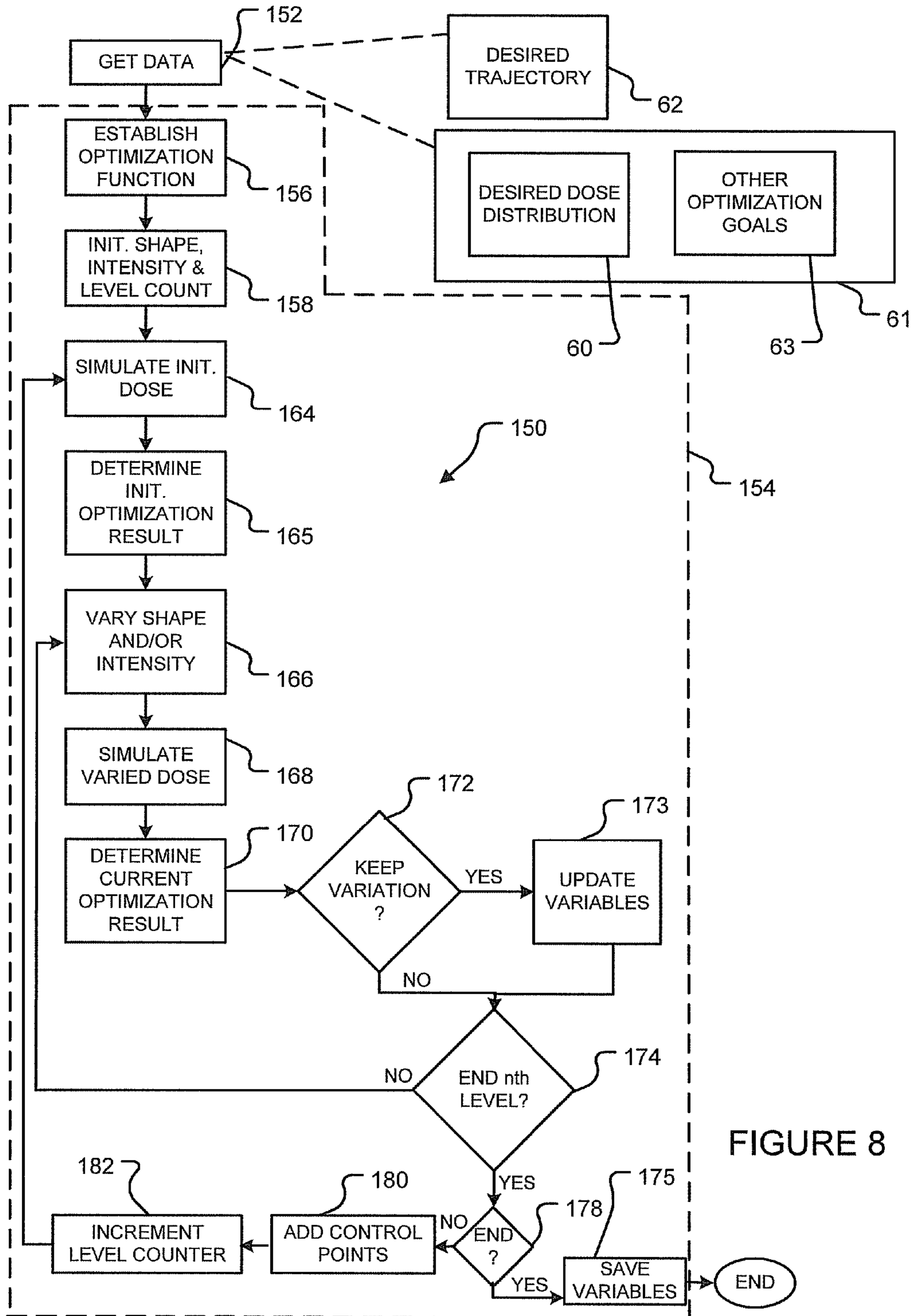

FIGURE 8

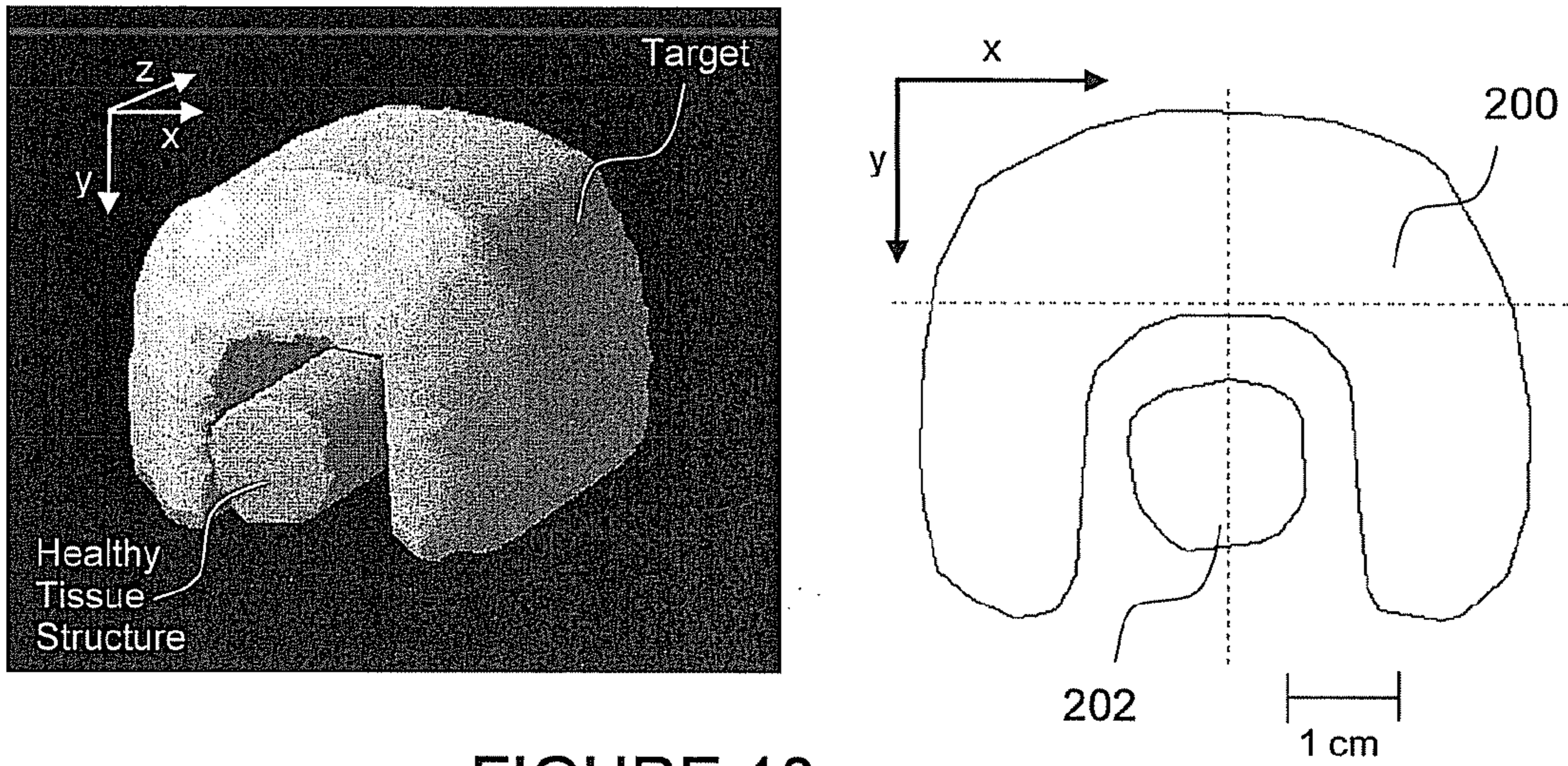

FIGURE 10

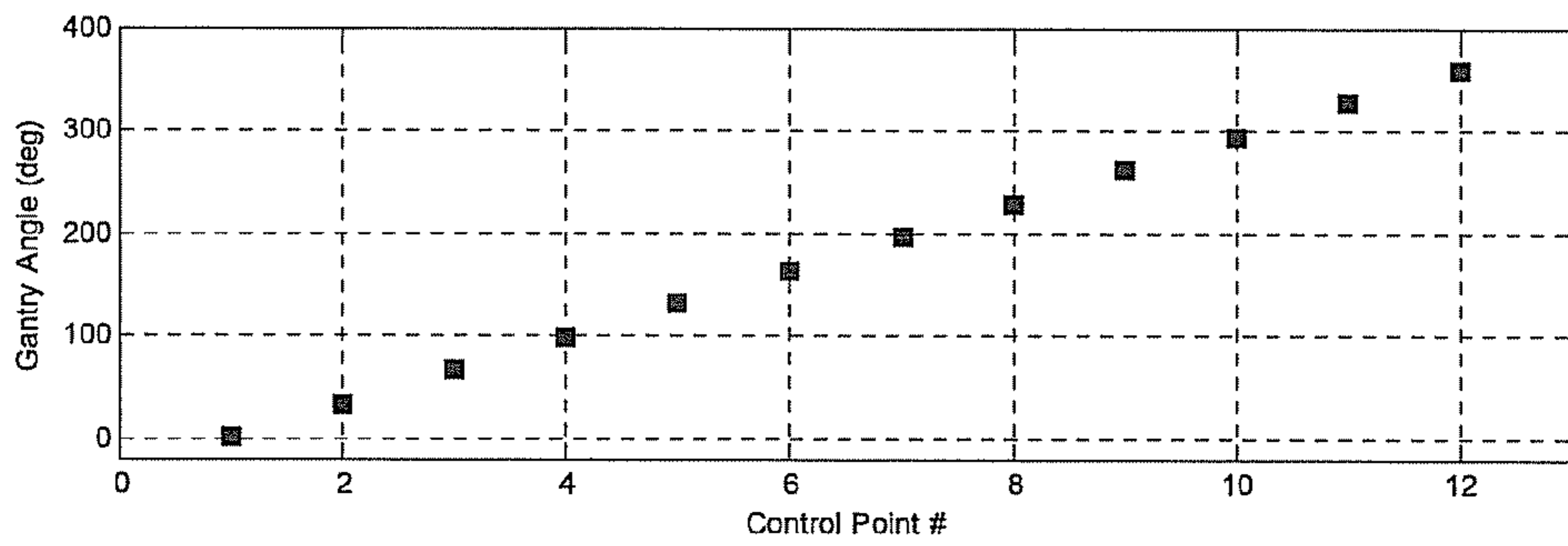

FIGURE 11A

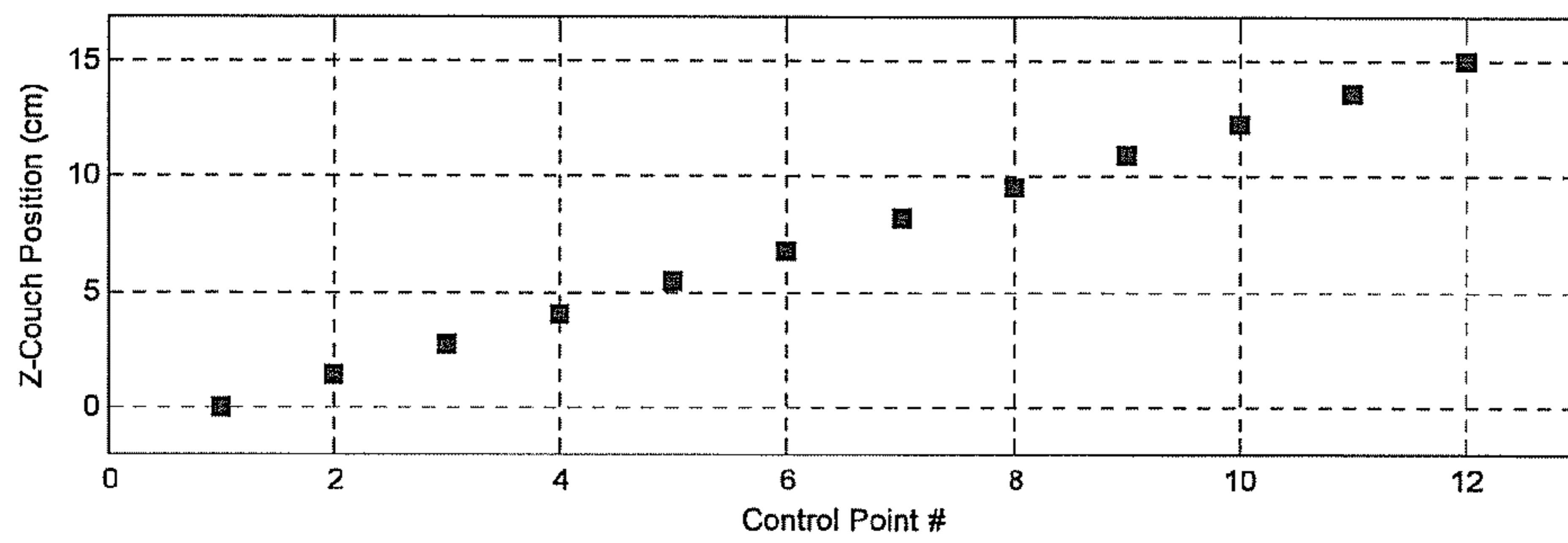

FIGURE 11B

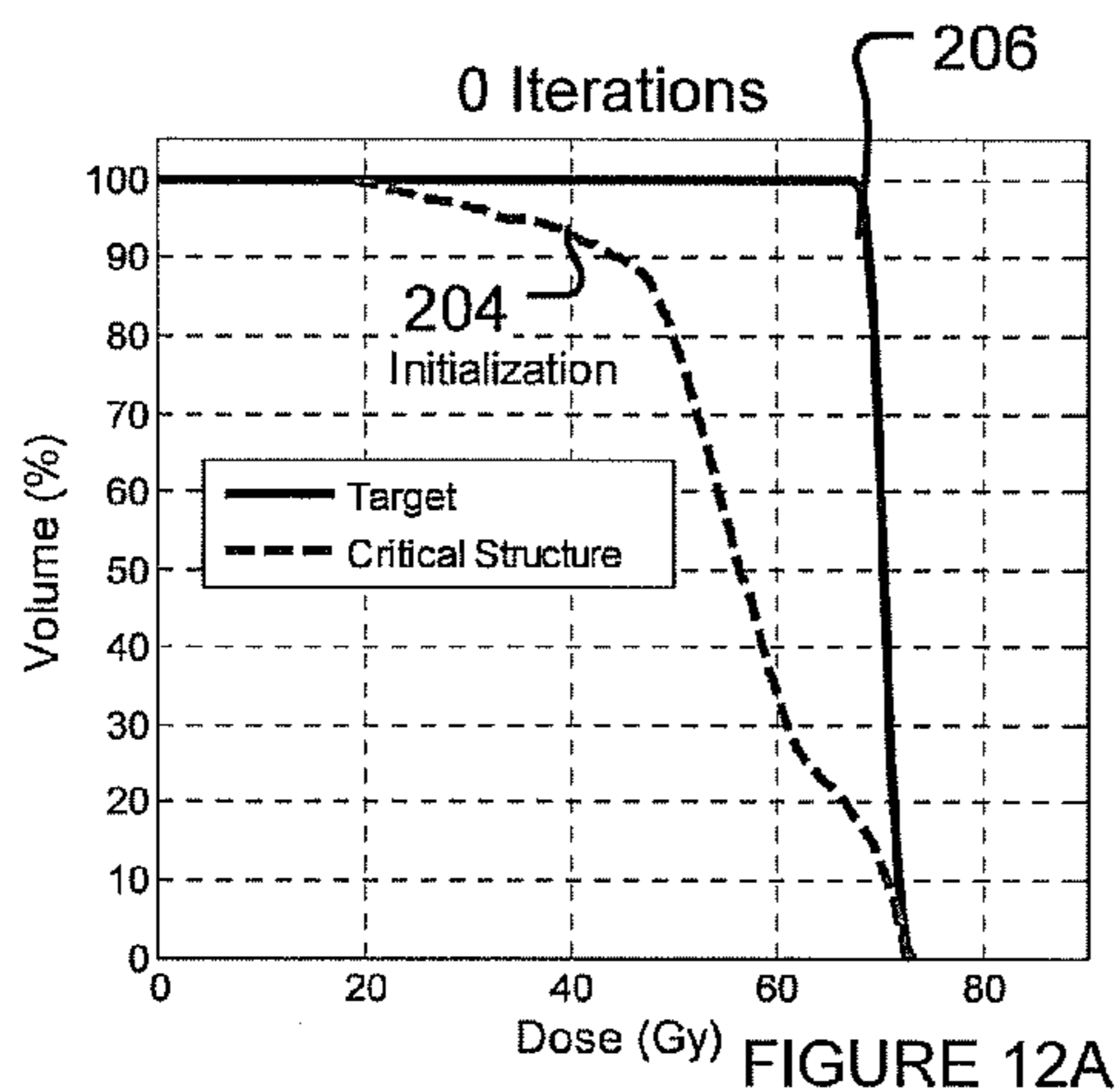

FIGURE 12A

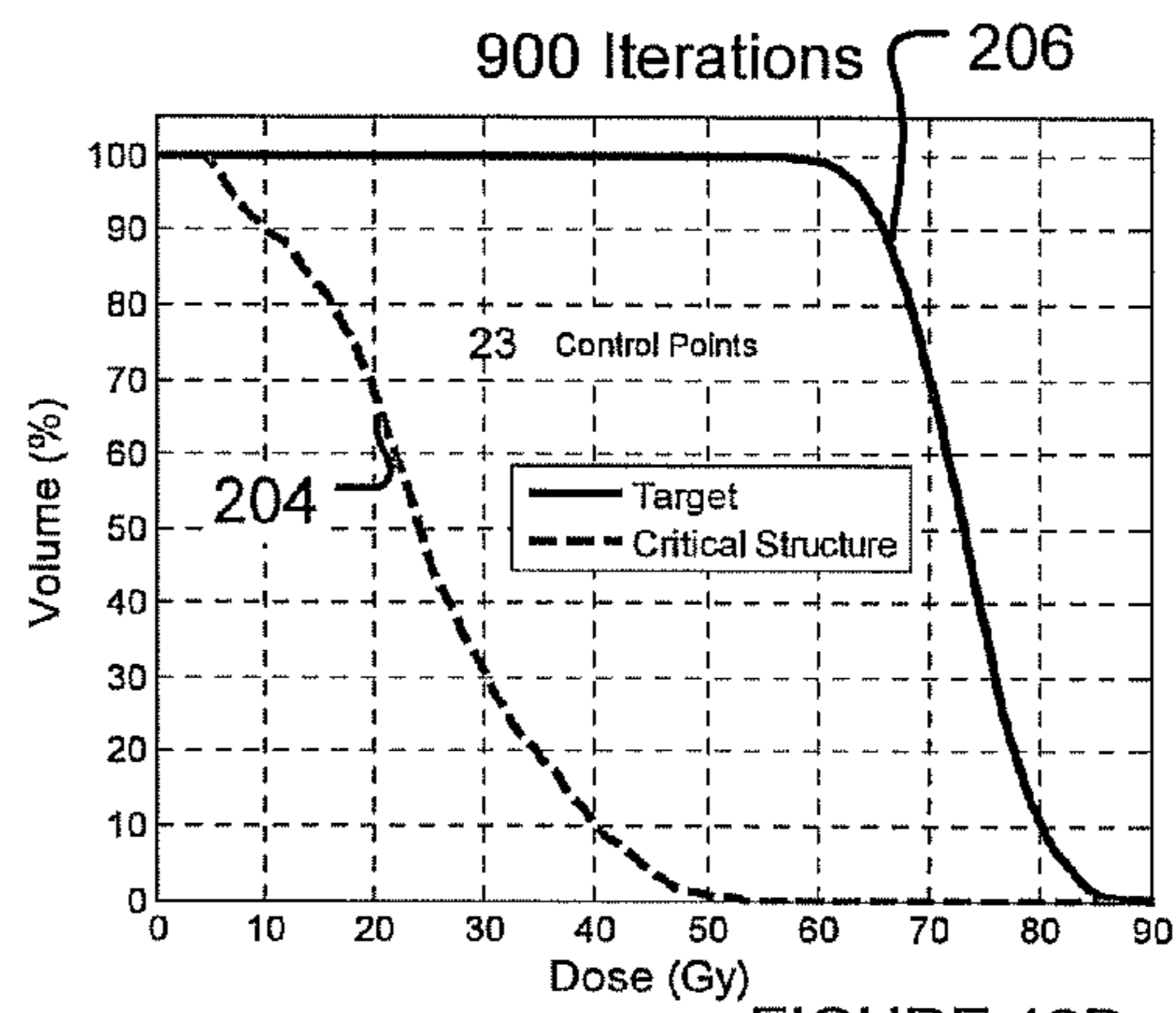

FIGURE 12B

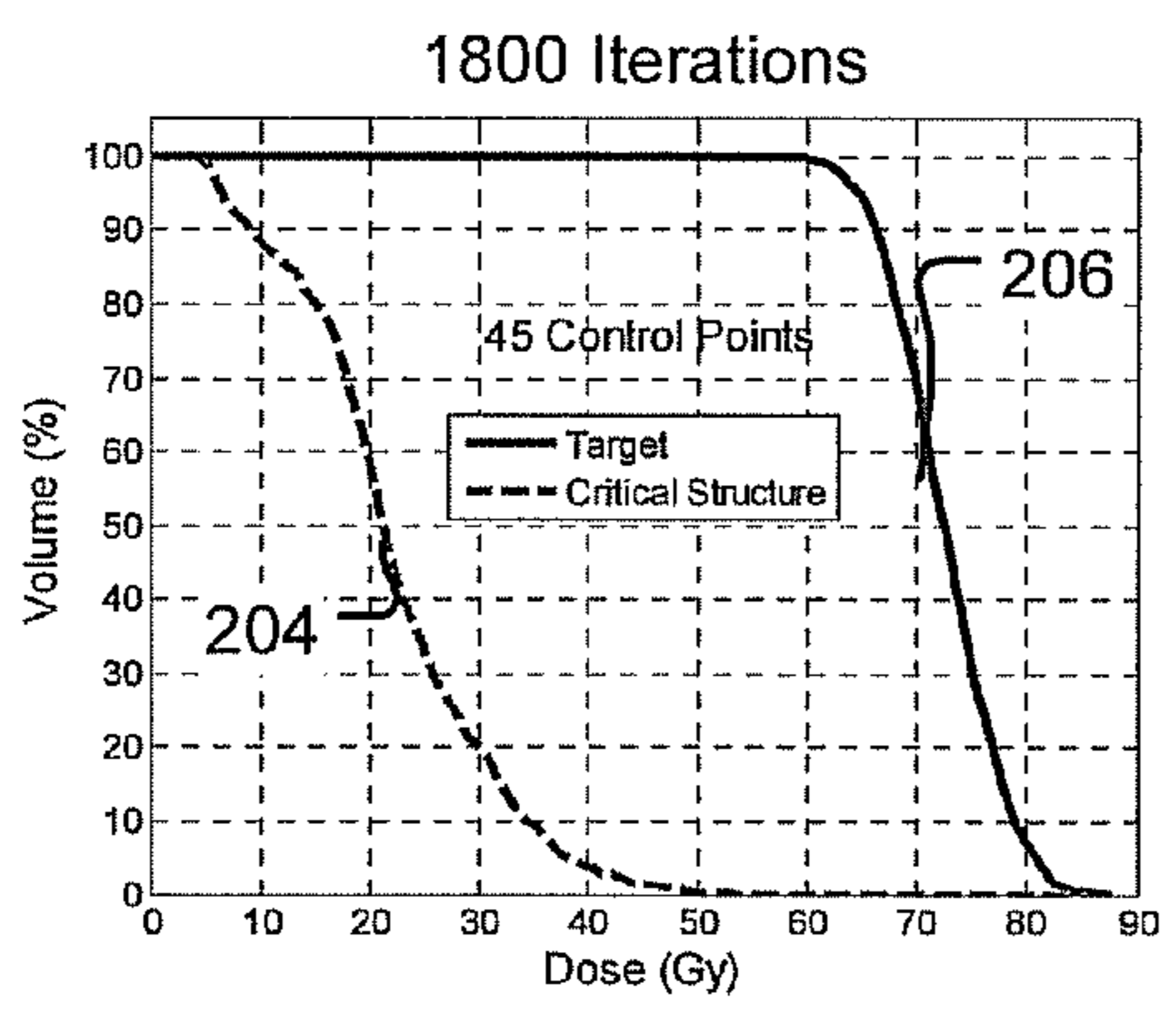

FIGURE 12C

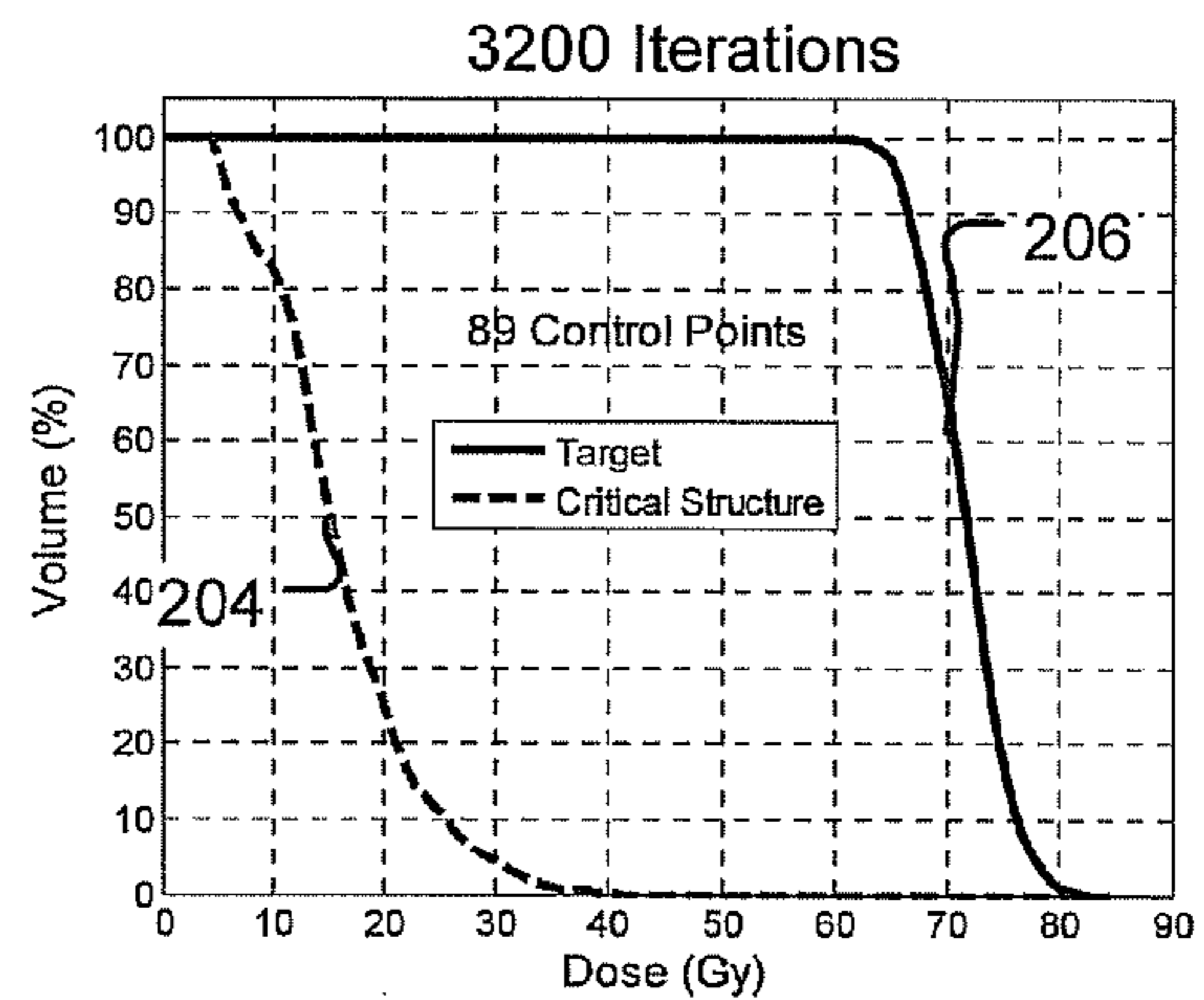

FIGURE 12D

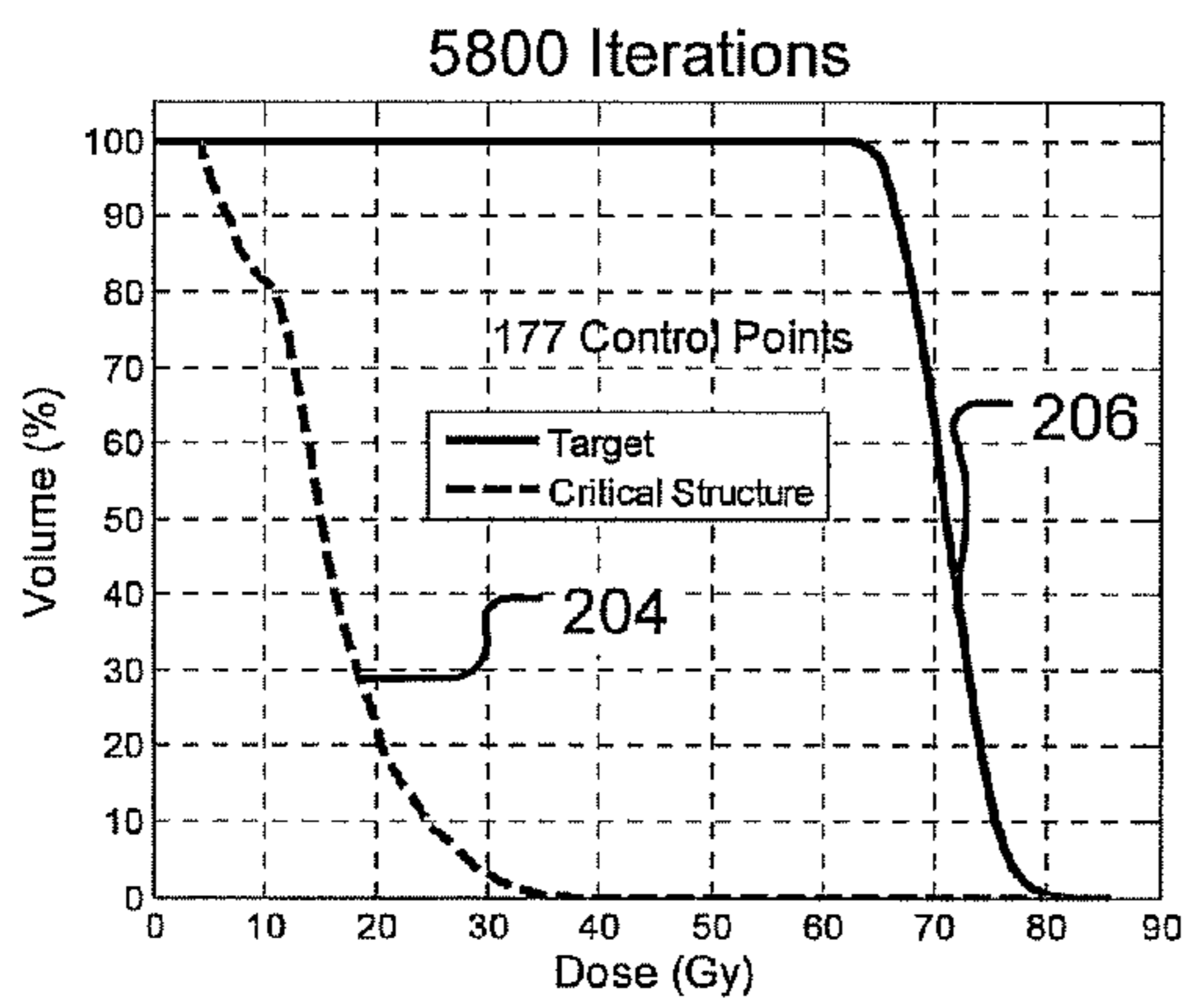

FIGURE 12E

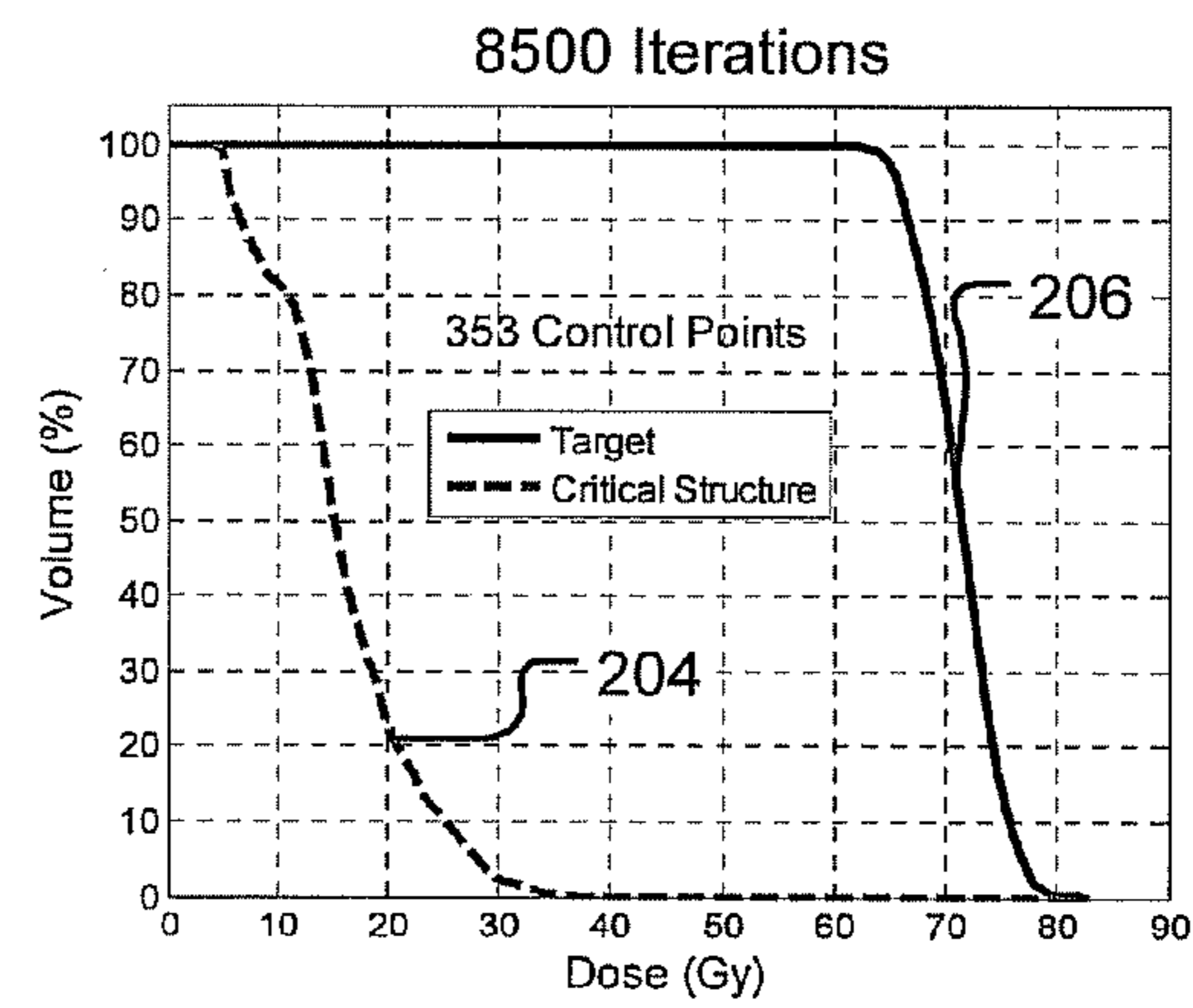

FIGURE 12F

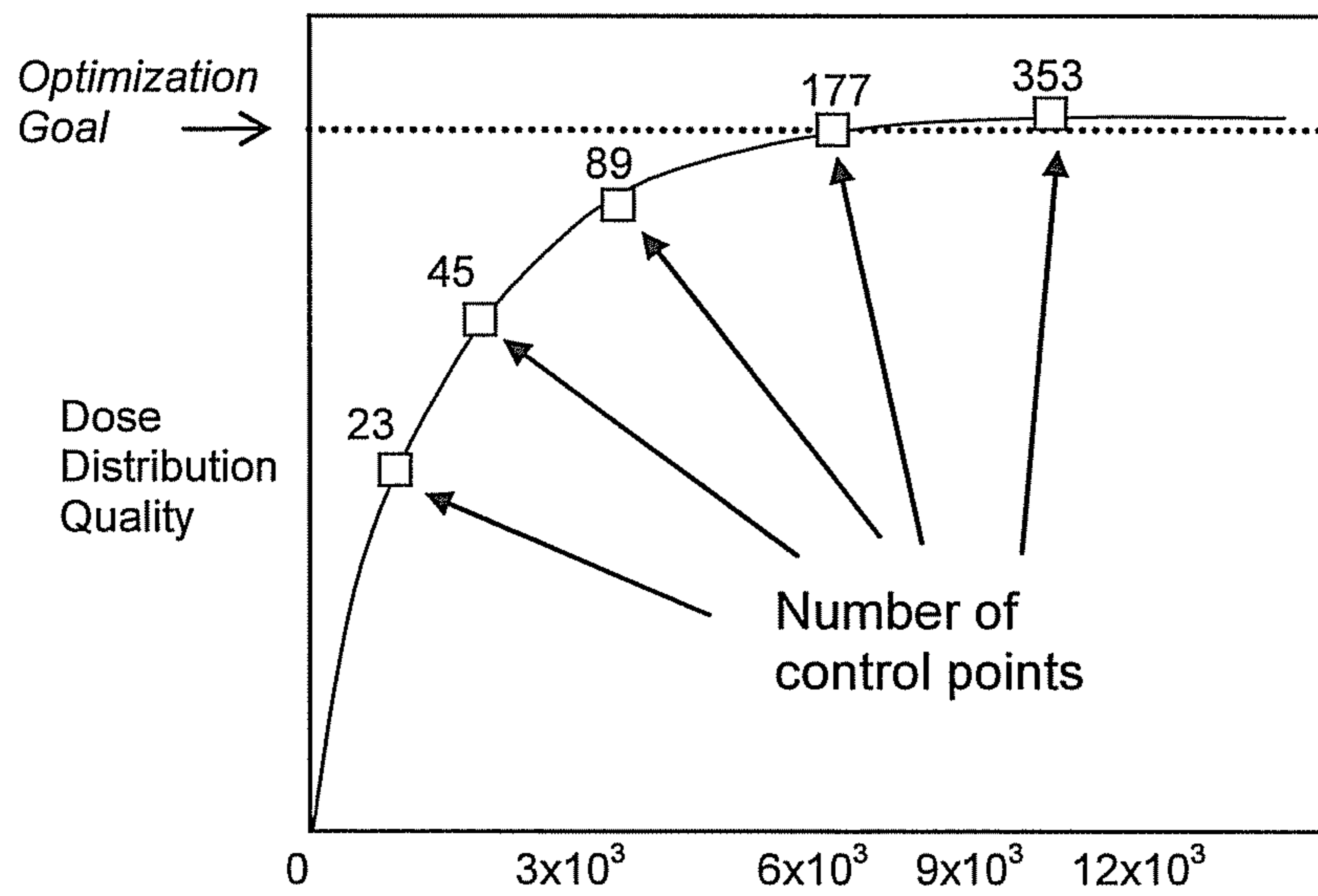
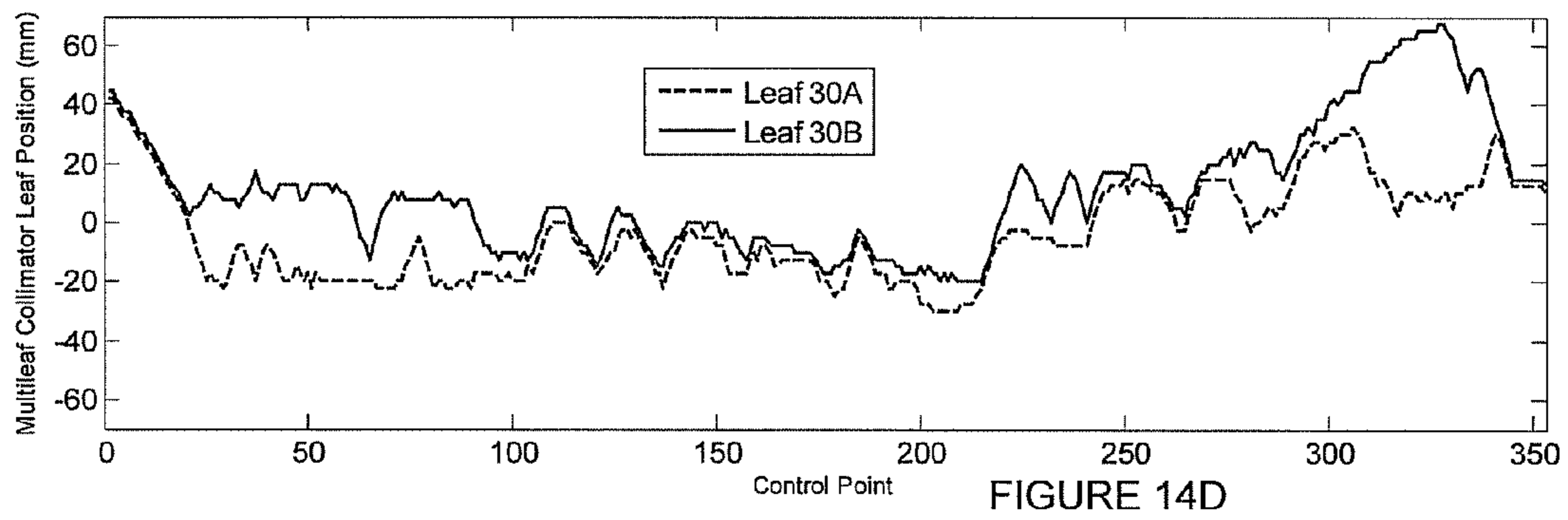
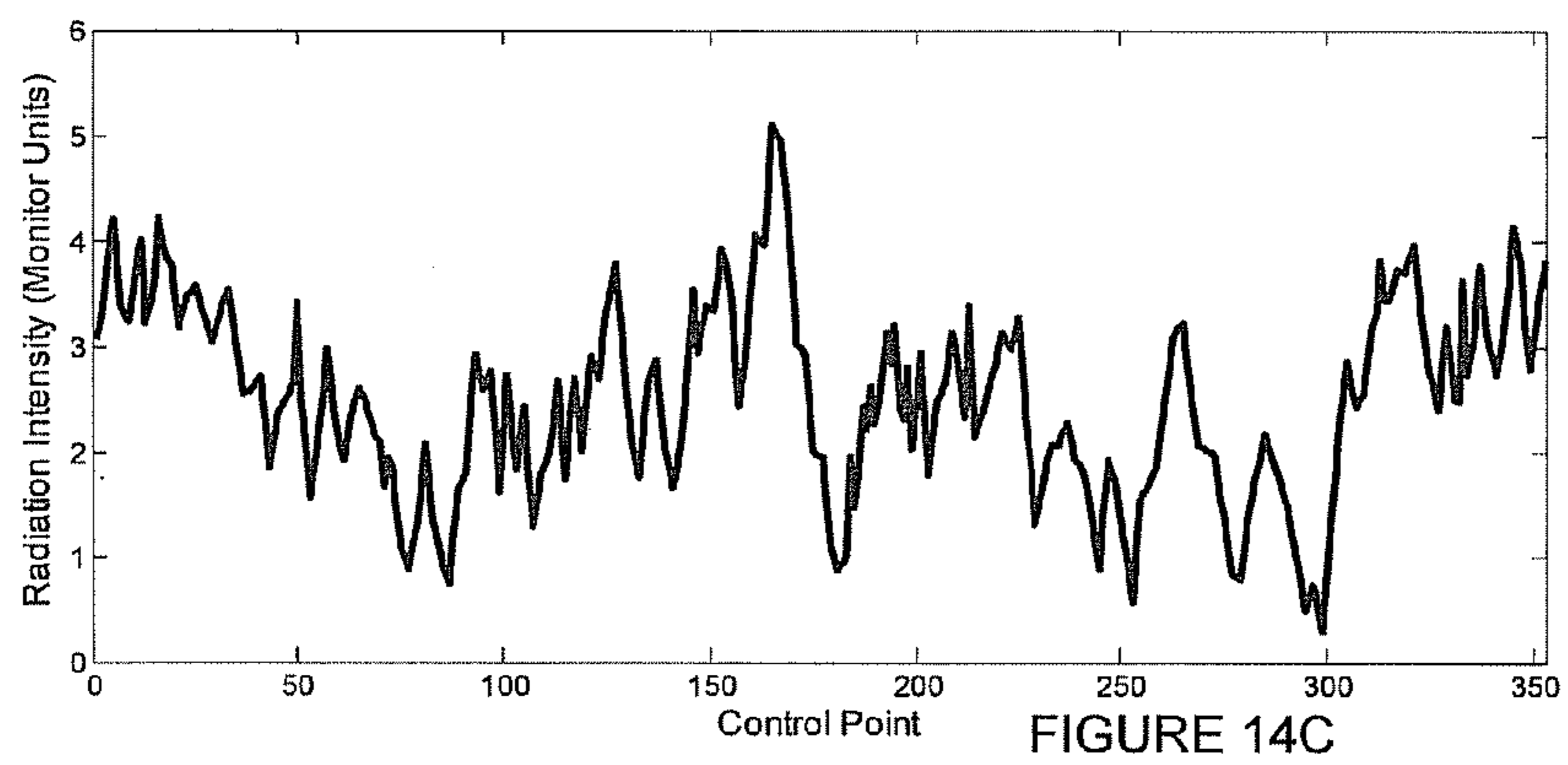
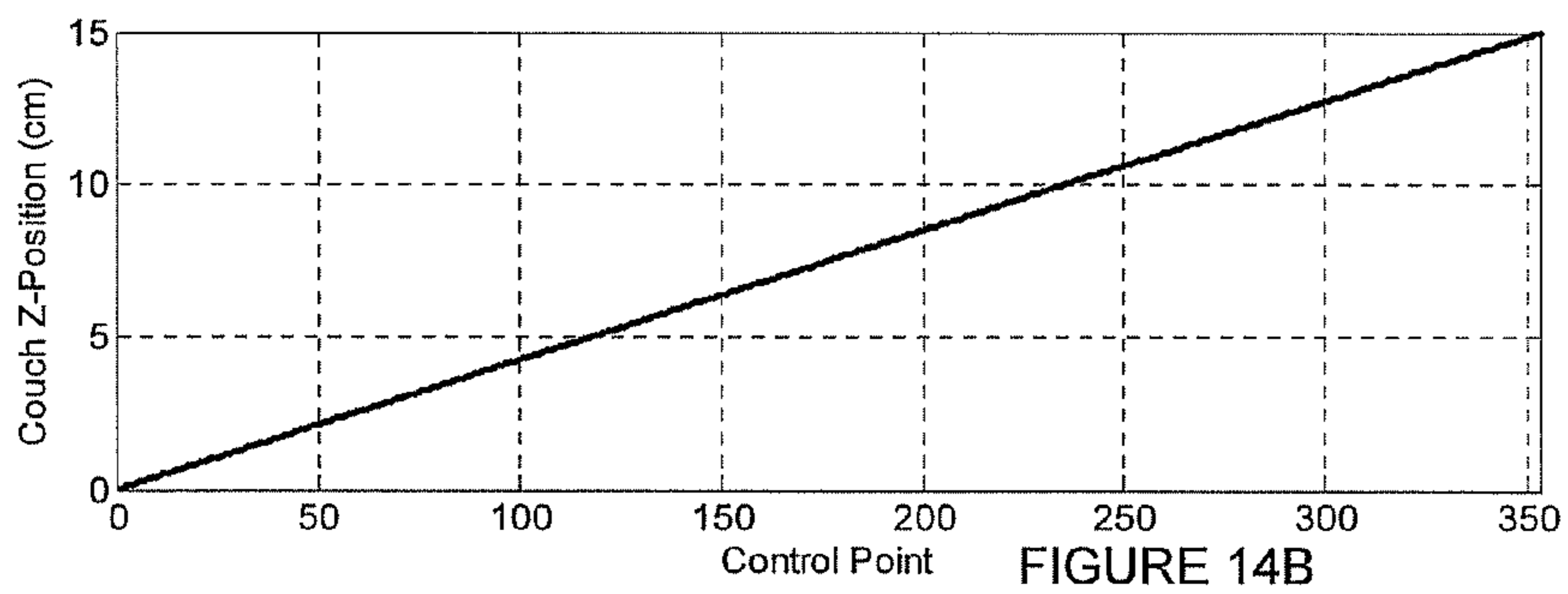
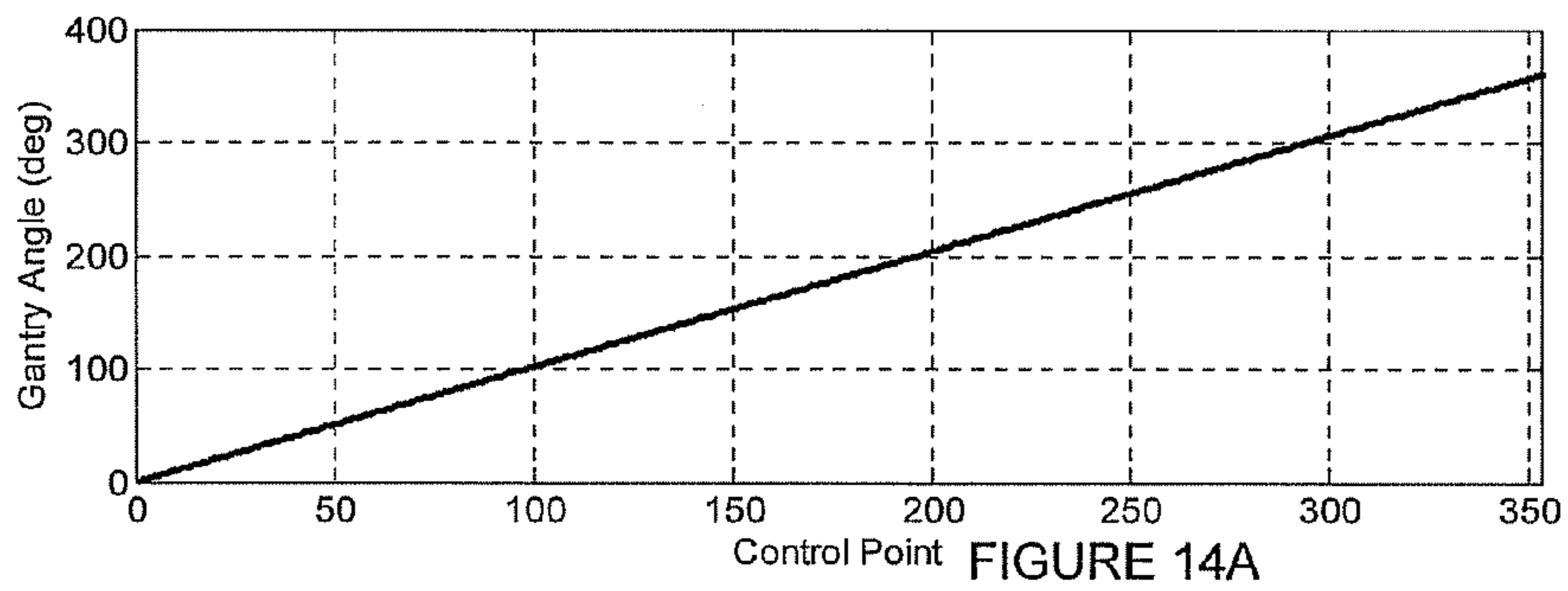

FIGURE 13



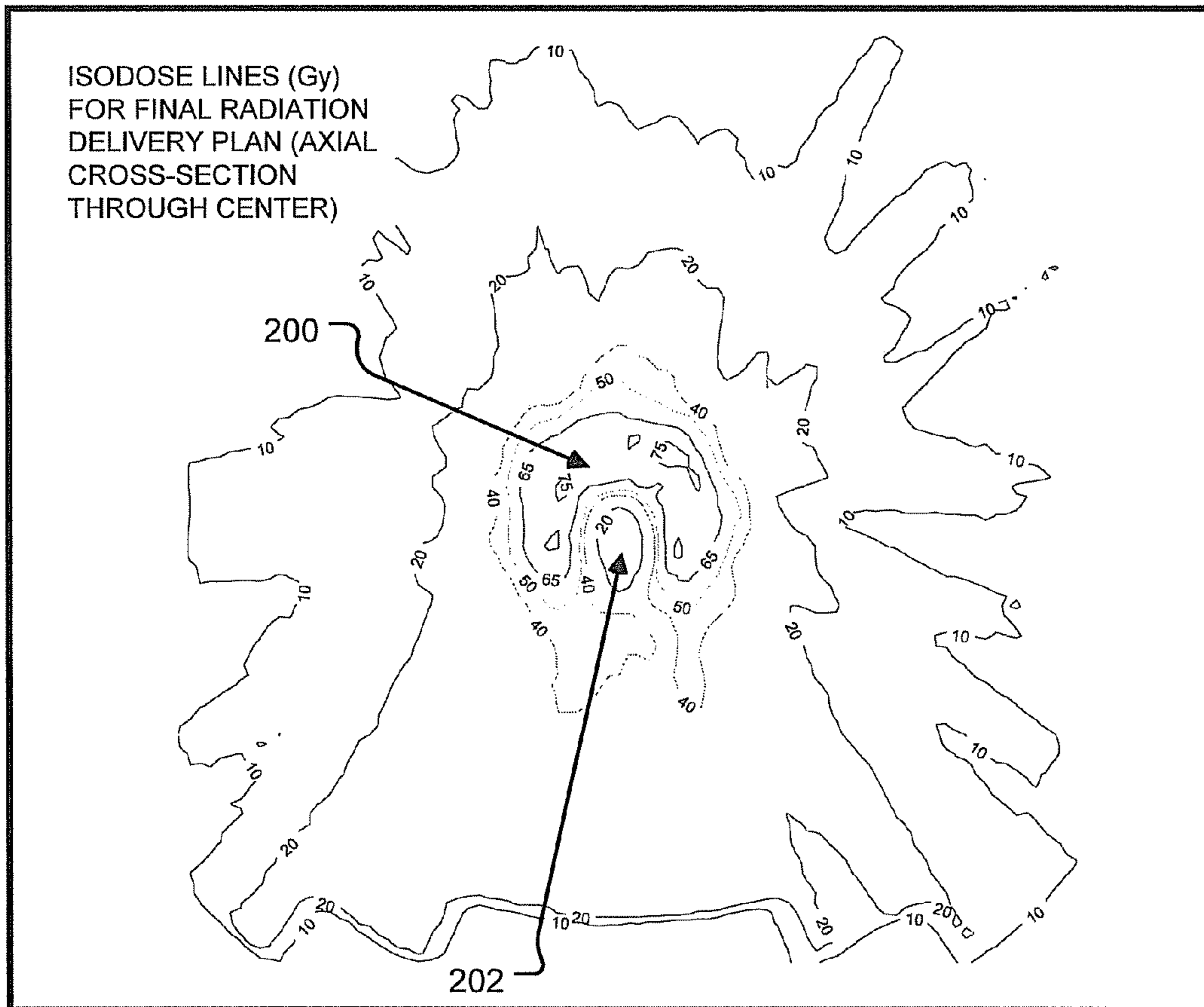
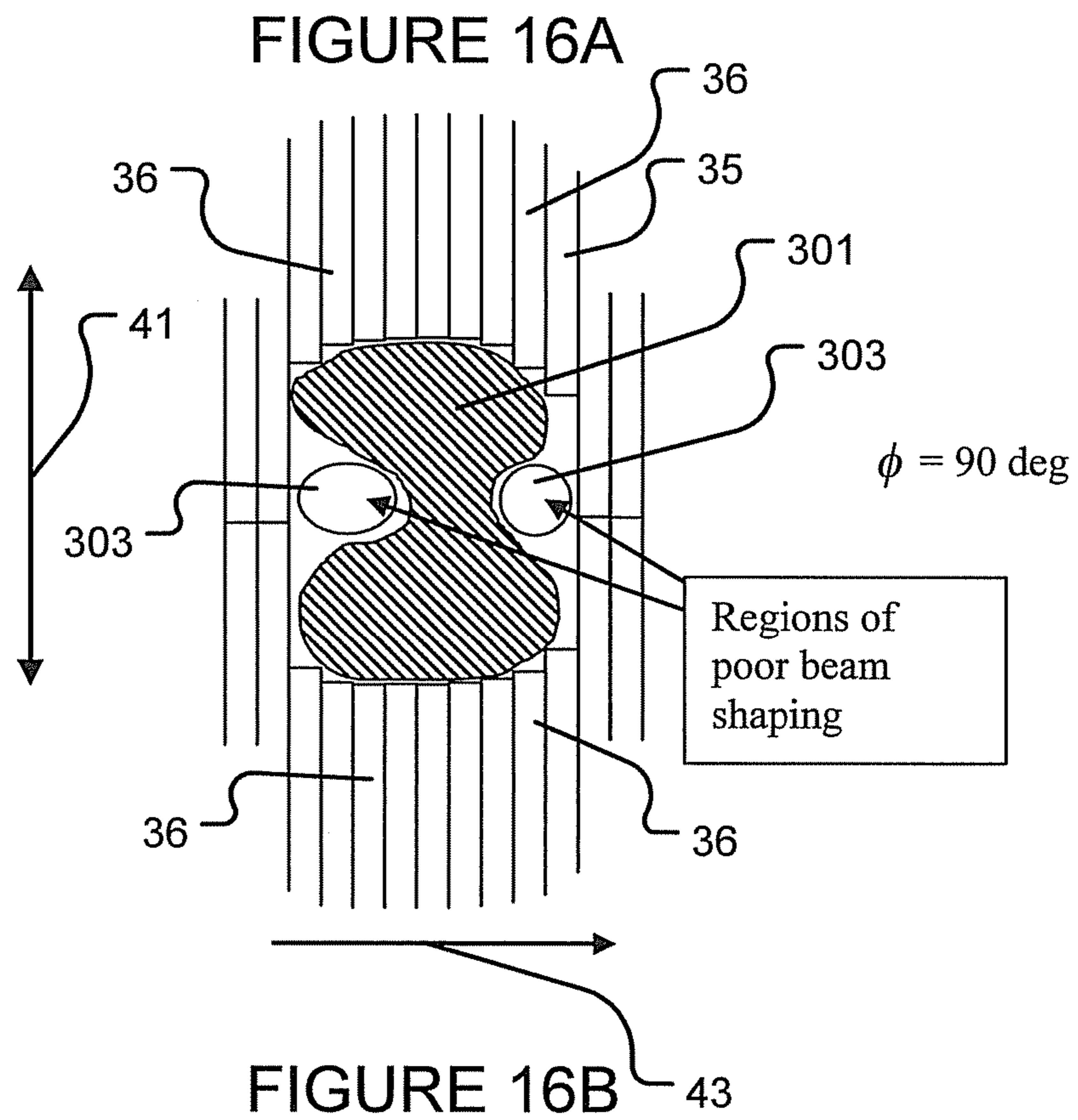
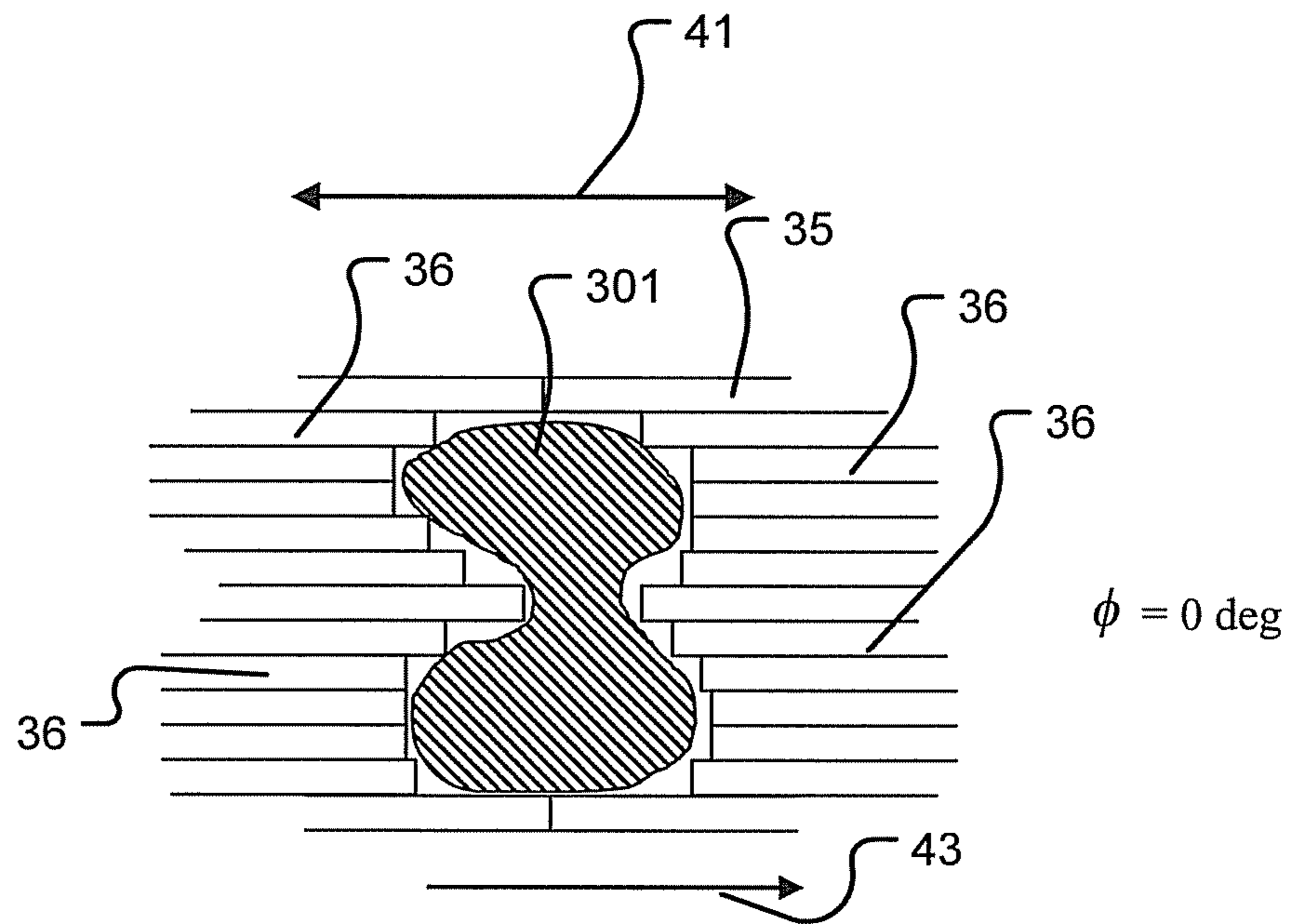

FIGURE 15



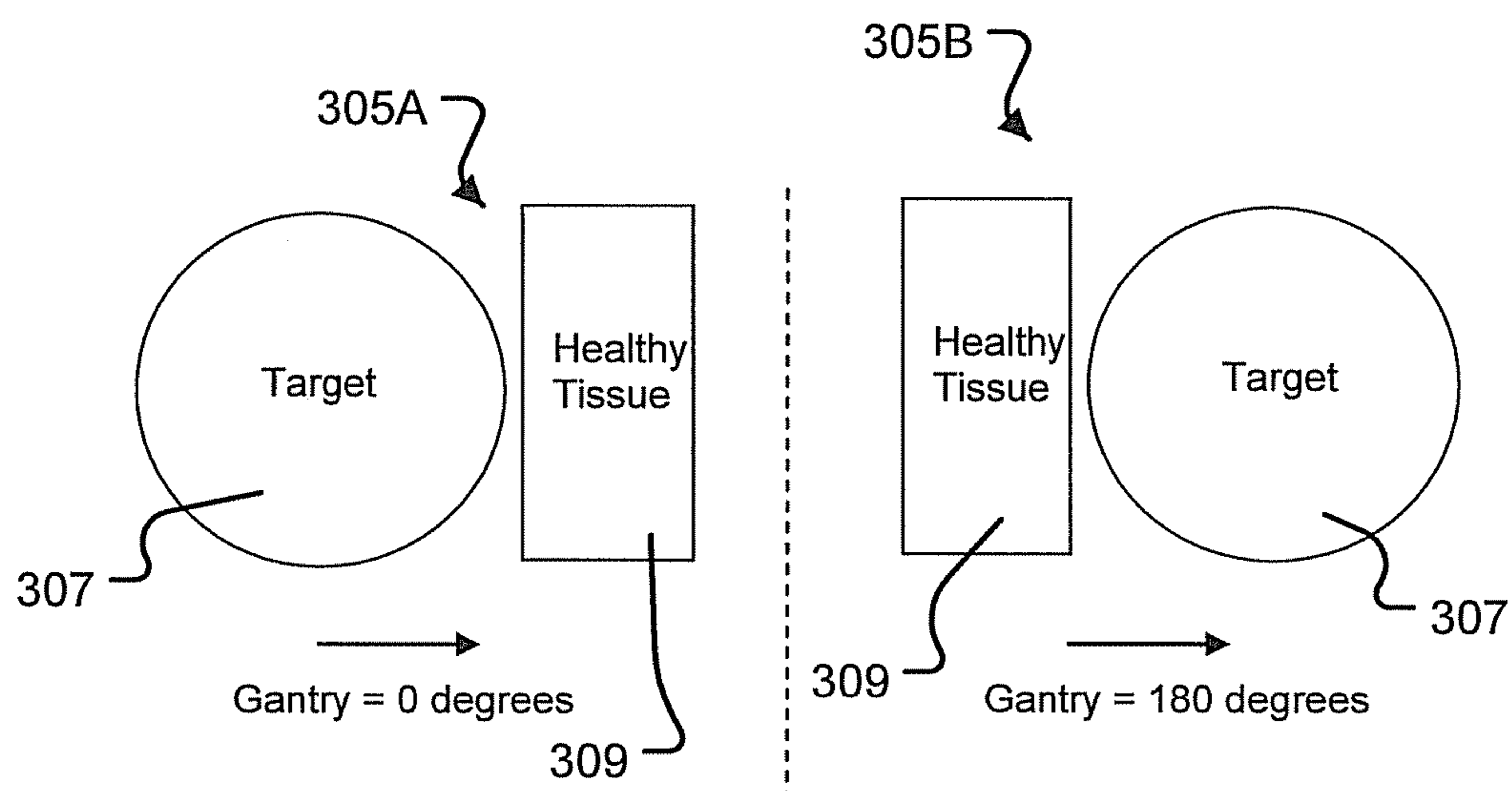
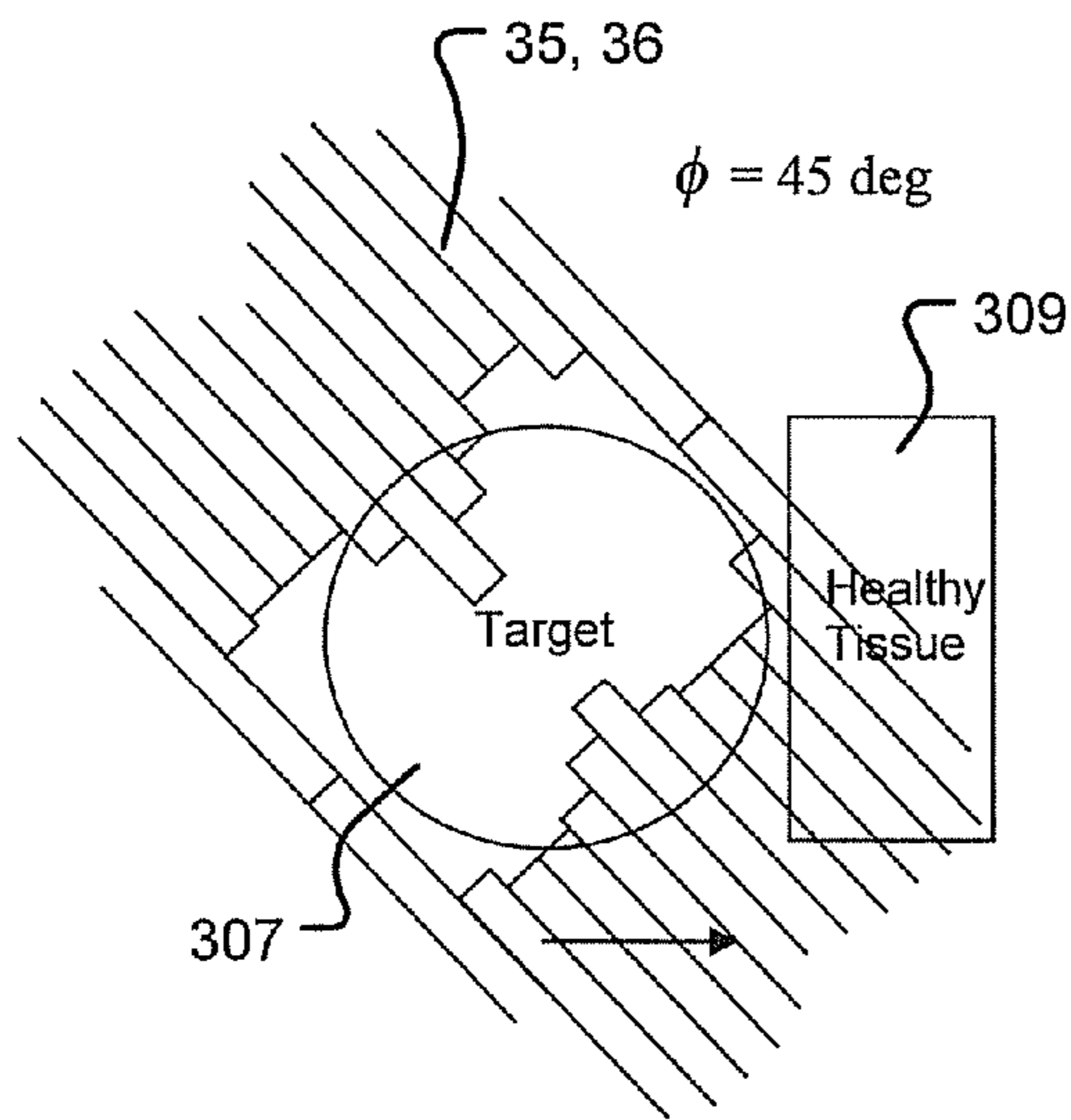
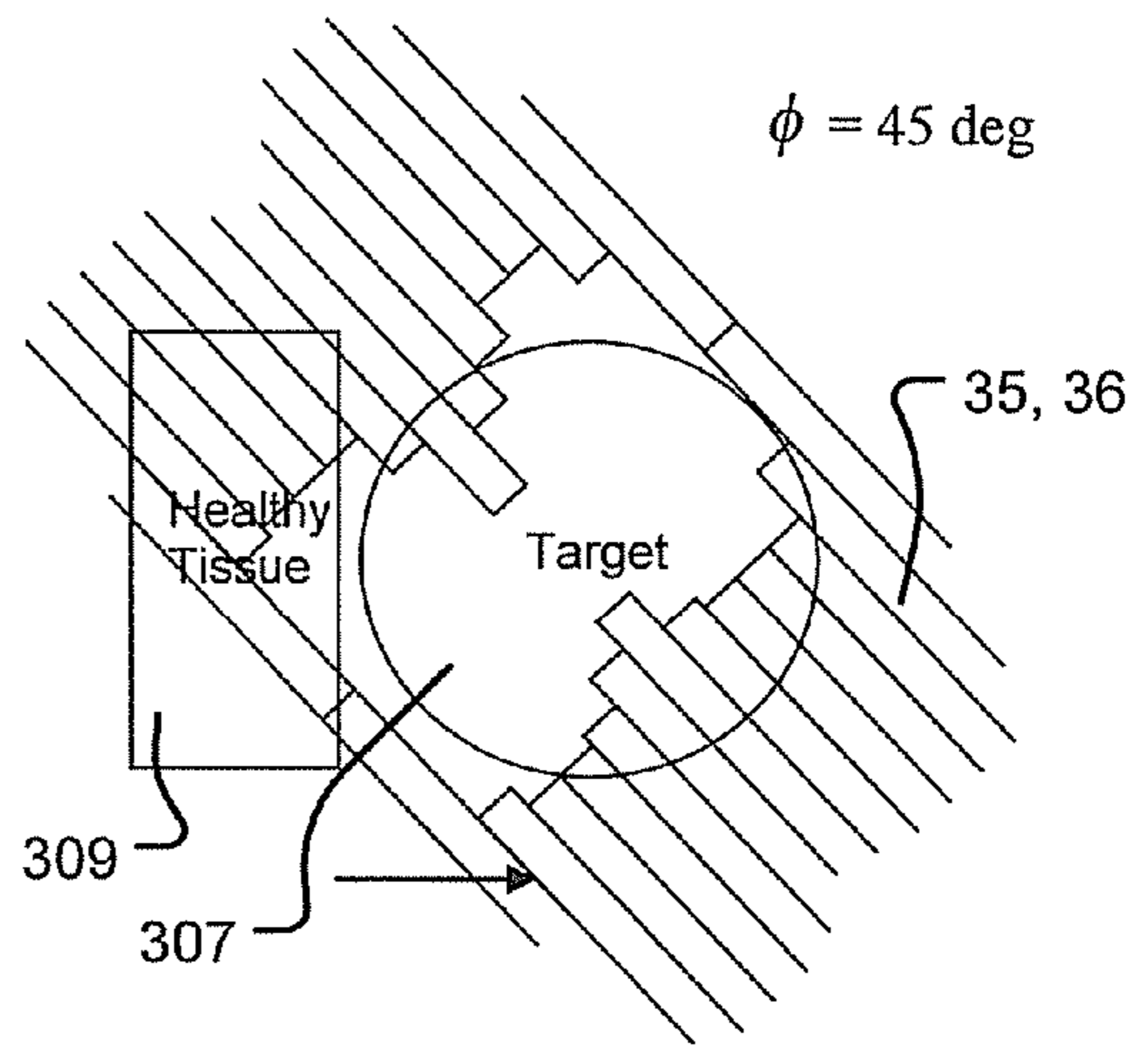

FIGURE 17



Gantry = 0 degrees
FIGURE 18A



Gantry = 180 degrees
FIGURE 18B

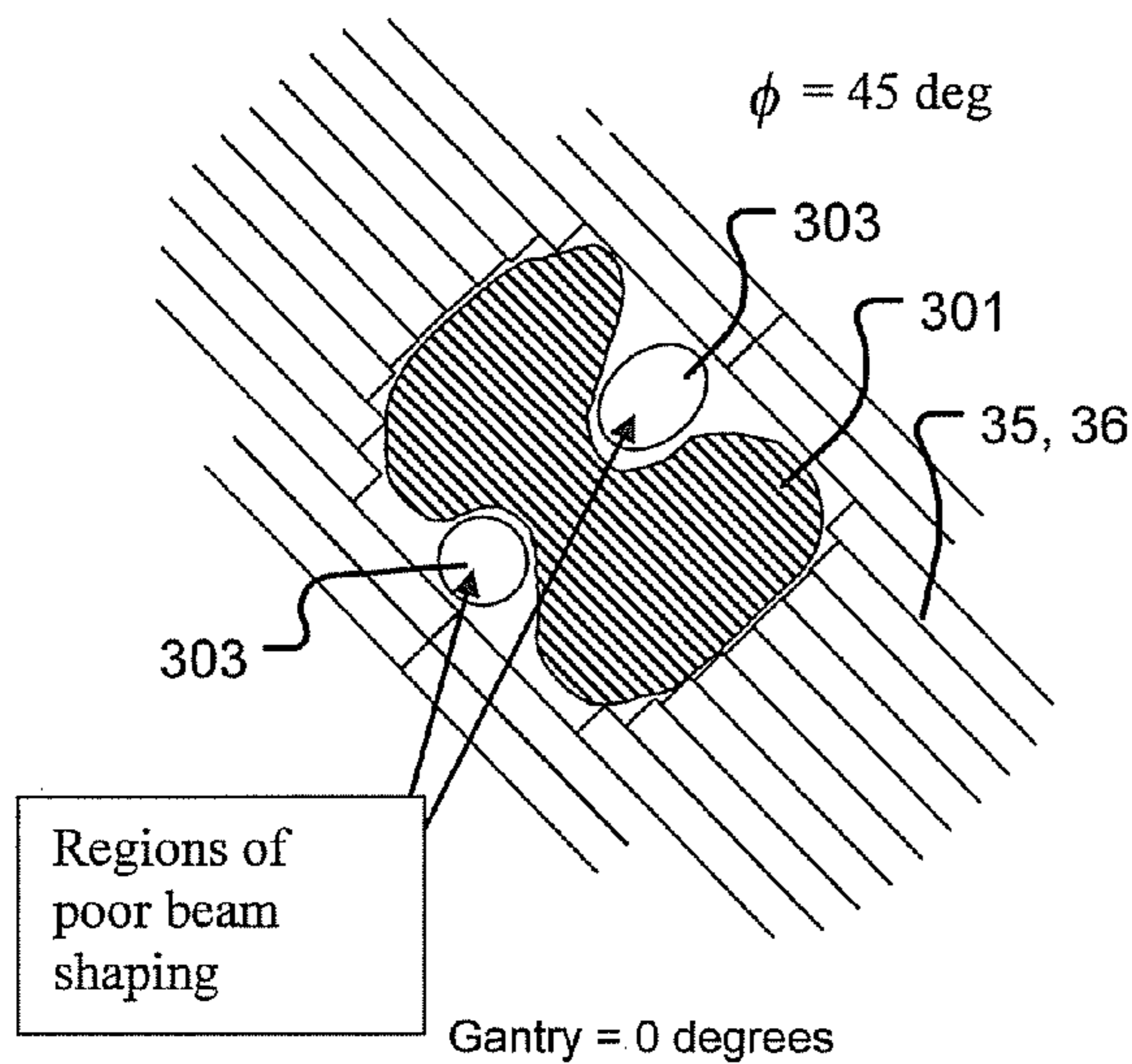

Gantry = 0 degrees
FIGURE 18C

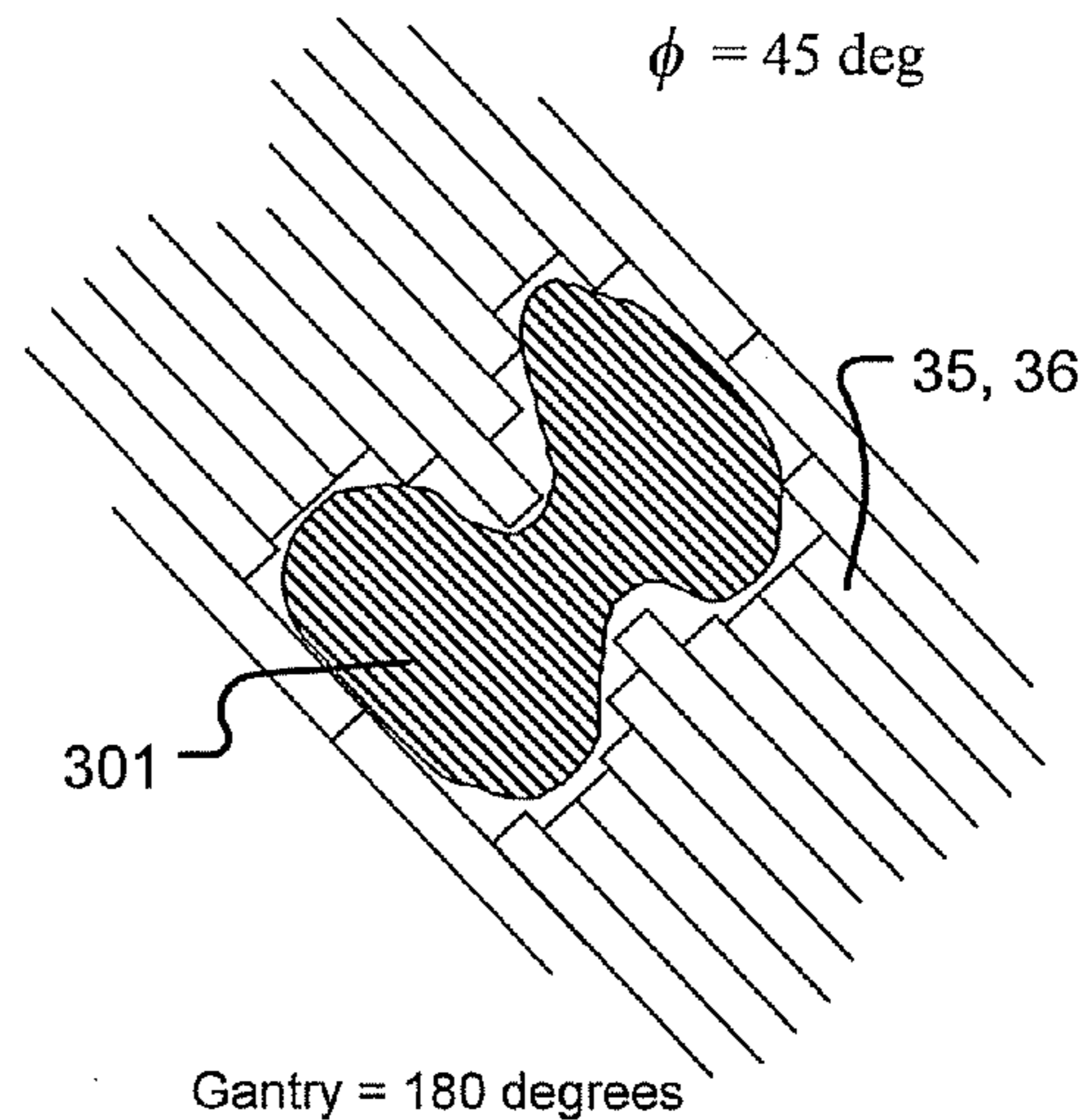

Gantry = 180 degrees
FIGURE 18D

METHODS AND APPARATUS FOR THE PLANNING AND DELIVERY OF RADIATION TREATMENTS

CROSS-REFERENCE TO RELATED APPLICATIONS

This application is a continuation of U.S. application Ser. No. 12/132,597 filed 3 Jun. 2008. U.S. application Ser. No. 12/132,597 is a continuation-in-part of U.S. application Ser. No. 11/996,932 which is a 35 USC §371 application having a 35 USC §371 date of 25 Jan. 2008 and corresponding to PCT/CA2006/001225. PCT/CA2006/001225 has an international filing date of 25 Jul. 2006 and claims priority from U.S. patent application No. 60/701,974 filed on 25 Jul. 2005.

PCT application No. PCT/CA2006/001225 and U.S. application Ser. Nos. 12/132,597, 11/996,932 and 60/701,974 are hereby incorporated herein by reference.

TECHNICAL FIELD

This invention relates to radiation treatment. The invention relates particularly to methods and apparatus for planning and delivering radiation to a subject to provide a desired three-dimensional distribution of radiation dose.

BACKGROUND

The delivery of carefully-planned doses of radiation may be used to treat various medical conditions. For example, radiation treatments are used, often in conjunction with other treatments, in the treatment and control of certain cancers. While it can be beneficial to deliver appropriate amounts of radiation to certain structures or tissues, in general, radiation can harm living tissue. It is desirable to target radiation on a target volume containing the structures or tissues to be irradiated while minimizing the dose of radiation delivered to surrounding tissues. Intensity modulated radiation therapy (IMRT) is one method that has been used to deliver radiation to target volumes in living subjects.

IMRT typically involves delivering shaped radiation beams from a few different directions. The radiation beams are typically delivered in sequence. The radiation beams each contribute to the desired dose in the target volume.

A typical radiation delivery apparatus has a source of radiation, such as a linear accelerator, and a rotatable gantry. The gantry can be rotated to cause a radiation beam to be incident on a subject from various different angles. The shape of the incident radiation beam can be modified by a multi-leaf collimator (MLC). A MLC has a number of leaves which are mostly opaque to radiation. The MLC leaves define an aperture through which radiation can propagate. The positions of the leaves can be adjusted to change the shape of the aperture and to thereby shape the radiation beam that propagates through the MLC. The MLC may also be rotatable to different angles.

Objectives associated with radiation treatment for a subject typically specify a three-dimensional distribution of radiation dose that it is desired to deliver to a target region within the subject. The desired dose distribution typically specifies dose values for voxels located within the target. Ideally, no radiation would be delivered to tissues outside of the target region. In practice, however, objectives associated with radiation treatment may involve specifying a maximum acceptable dose that may be delivered to tissues outside of the target.

Treatment planning involves identifying an optimal (or at least acceptable) set of parameters for delivering radiation to

a particular treatment volume. Treatment planning is not a trivial problem. The problem that treatment planning seeks to solve involves a wide range of variables including:

the three-dimensional configuration of the treatment volume;

the desired dose distribution within the treatment volume; the locations and radiation tolerance of tissues surrounding the treatment volume; and

constraints imposed by the design of the radiation delivery apparatus.

The possible solutions also involve a large number of variables including:

the number of beam directions to use;

the direction of each beam;

the shape of each beam; and

the amount of radiation delivered in each beam.

Various conventional methods of treatment planning are described in:

S. V. Spirou and C.-S. Chui. *A gradient inverse planning algorithm with dose-volume constraints*, Med. Phys. 25, 321-333 (1998);

Q. Wu and R. Mohand. *Algorithm and functionality of an intensity modulated radiotherapy optimization system*, Med. Phys. 27, 701-711 (2000);

S. V. Spirou and C.-S. Chui. *Generation of arbitrary intensity profiles by dynamic jaws or multileaf collimators*, Med. Phys. 21, 1031-1041 (1994);

P. Xia and L. J. Verhey. *Multileaf collimator leaf sequencing algorithm for intensity modulated beams with multiple static segments*, Med. Phys. 25, 1424-1434 (1998); and

K. Otto and B. G. Clark. *Enhancement of IMRT delivery through MLC rotation*, Phys. Med. Biol. 47, 3997-4017 (2002).

Acquiring sophisticated modern radiation treatment apparatus, such as a linear accelerator, can involve significant capital cost. Therefore it is desirable to make efficient use of such apparatus. All other factors being equal, a radiation treatment plan that permits a desired distribution of radiation dose to be delivered in a shorter time is preferable to a radiation treatment plan that requires a longer time to deliver. A treatment plan that can be delivered in a shorter time permits more efficient use of the radiation treatment apparatus. A shorter treatment plan also reduces the risk that a subject will move during delivery of the radiation in a manner that may significantly impact the accuracy of the delivered dose.

Despite the advances that have been made in the field of radiation therapy, there remains a need for radiation treatment methods and apparatus and radiation treatment planning methods and apparatus that provide improved control over the delivery of radiation, especially to complicated target volumes. There also remains a need for such methods and apparatus that can deliver desired dose distributions relatively quickly.

SUMMARY

One aspect of the invention provides a method for planning delivery of radiation dose to a target area within a subject. The method comprises: defining a set of one or more optimization goals, the set of one or more optimization goals comprising a desired dose distribution in the subject; specifying an initial plurality of control points along an initial trajectory, the initial trajectory involving relative movement between a radiation source and the subject in a source trajectory direction; and iteratively optimizing a simulated dose distribution relative to the set of one or more optimization goals to determine one or more radiation delivery parameters associated with each of

the initial plurality of control points. For each of the initial plurality of control points, the one or more radiation delivery parameters may comprise positions of a plurality of leaves of a multi-leaf collimator (MLC). The MLC leaves may be moveable in a leaf-translation direction. During relative movement between the radiation source and the subject along the initial trajectory, the leaf-translation direction is oriented at a MLC orientation angle ϕ with respect to the source trajectory direction and wherein an absolute value of the MLC orientation angle ϕ satisfies $0^\circ < |\phi| < 90^\circ$.

Another aspect of the invention provides a method for delivering radiation dose to a target area within a subject. The method comprises: defining a trajectory for relative movement between a treatment radiation source and the subject in a source trajectory direction; determining a radiation delivery plan; and while effecting relative movement between the treatment radiation source and the subject along the trajectory, delivering a treatment radiation beam from the treatment radiation source to the subject according to the radiation delivery plan to impart a dose distribution on the subject. Delivering the treatment radiation beam from the treatment radiation source to the subject comprises varying at least one of: an intensity of the treatment radiation beam; and a shape of the treatment radiation beam over at least a portion of the trajectory.

Varying at least one of the intensity of the treatment radiation beam and the shape of the treatment radiation beam over at least the portion of the trajectory, may comprise varying positions of a plurality of leaves of a multi-leaf collimator (MLC) in a leaf-translation direction. During relative movement between the treatment radiation source and the subject along the trajectory, the leaf-translation direction may be oriented at a MLC orientation angle ϕ with respect to the source trajectory direction wherein an absolute value of the MLC orientation angle ϕ satisfies $0^\circ < |\phi| < 90^\circ$.

Varying at least one of the intensity of the treatment radiation beam and the shape of the treatment radiation beam over at least the portion of the trajectory may comprise varying a rate of radiation output of the radiation source while effecting continuous relative movement between the treatment radiation source and the subject along the trajectory.

Other aspects of the invention provide program products comprising computer readable instructions which, when executed by a processor, cause the processor to execute, at least in part, any of the methods described herein. Other aspects of the invention provide systems comprising, inter alia, controllers configured to execute, at least in part, any of the methods described herein.

Further aspects of the invention and features of embodiments of the invention are set out below and illustrated in the accompanying drawings.

BRIEF DESCRIPTION OF THE DRAWINGS

The appended drawings illustrate non-limiting example embodiments of the invention.

FIG. 1 is a schematic view of an exemplary radiation delivery apparatus in conjunction with which the invention may be practised.

FIG. 1A is a schematic view of another exemplary radiation delivery apparatus in conjunction with which the invention may be practised.

FIG. 2 is a schematic illustration of a trajectory.

FIG. 3A is a schematic cross-sectional view of a beam-shaping mechanism.

FIG. 3B is a schematic beam's eye plan view of a multi-leaf collimator-type beam-shaping mechanism.

FIG. 3C schematically depicts a system for defining the angle of leaf-translation directions about the beam axis.

FIG. 4A is a flow chart illustrating a method of optimizing dose delivery according to a particular embodiment of the invention.

FIG. 4B is a schematic flow chart depicting a method for planning and delivering radiation to a subject according to a particular embodiment of the invention.

FIGS. 5A, 5B and 5C illustrate dividing an aperture into beamlets according to a particular embodiment of the invention.

FIG. 6 graphically depicts the error associated with a dose simulation calculation versus the number of control points used to perform the dose simulation calculation.

FIG. 7 graphically depicts dose quality versus the number of optimization iterations for several different numbers of control points.

FIG. 8 represents a flow chart which schematically illustrates a method of optimizing dose delivery according to another embodiment of the invention where the number of control points is varied over the optimization process.

FIG. 9 graphically depicts the dose distribution quality versus the number of iterations for the FIG. 8 optimization method where the number of control points is varied over the optimization process.

FIG. 10 is a depiction of sample target tissue and healthy tissue used in an illustrative example of an implementation of a particular embodiment of the invention.

FIGS. 11A and 11B respectively depict the initial control point positions of the motion axes corresponding to a trajectory used in the FIG. 10 example.

FIGS. 12A-12F depict a dose volume histogram (DVH) which is representative of the dose distribution quality at various stages of the optimization process of the FIG. 10 example.

FIG. 13 another graphical depiction of the optimization process of the FIG. 10 example.

FIGS. 14A-14D show the results (the motion axes parameters, the intensity and the beam shaping parameters) of the optimization process of the FIG. 10 example.

FIG. 15 plots contour lines of constant dose (isodose lines) in a two-dimensional cross-sectional slice of the target region in the FIG. 10 example.

FIGS. 16A and 16B show examples of how the selection of a particular constant MLC orientation angle may impact treatment plan quality and ultimately the radiation dose that is delivered to a subject.

FIG. 17 schematically depicts how target and healthy tissue will look for opposing beam directions.

FIGS. 18A and 18B show an MLC and the respective projections of a target and healthy tissue for opposing beam directions corresponding to opposing gantry angles.

FIGS. 18C and 18D show an MLC and the respective projections of a desired beam shape for opposing beam directions corresponding to opposing gantry angles.

DESCRIPTION

Throughout the following description specific details are set forth in order to provide a more thorough understanding to persons skilled in the art. However, well known elements may not have been shown or described in detail to avoid unnecessarily obscuring the disclosure. Accordingly, the description and drawings are to be regarded in an illustrative, rather than a restrictive, sense.

This invention relates to the planning and delivery of radiation treatments by modalities which involve moving a radia-

5

tion source along a trajectory relative to a subject while delivering radiation to the subject. In some embodiments the radiation source is moved continuously along the trajectory while in some embodiments the radiation source is moved intermittently. Some embodiments involve the optimization of the radiation delivery plan to meet various optimization goals while meeting a number of constraints. For each of a number of control points along a trajectory, a radiation delivery plan may comprise: a set of motion axes parameters, a set of beam shape parameters and a beam intensity.

FIG. 1 shows an example radiation delivery apparatus 10 comprising a radiation source 12 capable of generating or otherwise emitting a beam 14 of radiation. Radiation source 12 may comprise a linear accelerator, for example. A subject S is positioned on a table or "couch" 15 which can be placed in the path of beam 14. Apparatus 10 has a number of movable parts that permit the location of radiation source 12 and orientation of radiation beam 14 to be moved relative to subject S. These parts may be referred to collectively as a beam positioning mechanism 13.

In the illustrated radiation delivery apparatus 10, beam positioning mechanism 13 comprises a gantry 16 which supports radiation source 12 and which can be rotated about an axis 18. Axis 18 and beam 14 intersect at an isocenter 20. Beam positioning mechanism 13 also comprises a moveable couch 15. In exemplary radiation delivery apparatus 10, couch 15 can be translated in any of three orthogonal directions (shown in FIG. 1 as X, Y, and Z directions) and can be rotated about an axis 22. In some embodiments, couch 15 can be rotated about one or more of its other axes. The location of source 12 and the orientation of beam 14 can be changed (relative to subject S) by moving one or more of the movable parts of beam positioning mechanism 13.

Each separately-controllable means for moving source 12 and/or orienting beam 14 relative to subject S may be termed a "motion axis". In some cases, moving source 12 or beam 14 along a particular trajectory may require motions of two or more motion axes. In exemplary radiation delivery apparatus 10, motion axes include:

- rotation of gantry 16 about axis 18;
- translation of couch 15 in any one or more of the X, Y, Z directions; and
- rotation of couch 15 about axis 22.

Radiation delivery apparatus 10 typically comprises a control system 23 capable of controlling, among other things, the movement of its motion axes and the intensity of radiation source 12. Control system 23 may generally comprise hardware components and/or software components. In the illustrated embodiment, control system 23 comprises a controller 24 capable of executing software instructions. Control system 23 is preferably capable of receiving (as input) a set of desired positions for its motion axes and, responsive to such input, controllably moving one or more of its motion axes to achieve the set of desired motion axes positions. At the same time, control system 23 may also control the intensity of radiation source 12 in response to input of a set of desired radiation intensities.

While radiation delivery apparatus 10 represents a particular type of radiation delivery apparatus in conjunction with which the invention may be implemented, it should be understood that the invention may be implemented on different radiation delivery apparatus which may comprise different motion axes. In general, the invention may be implemented in conjunction with any set of motion axes that can create relative movement between a radiation source 12 and a subject S, from a starting point along a trajectory to an ending point.

6

Another example of a radiation delivery apparatus 10A that provides an alternative set of motion axes is shown in FIG. 1A. In exemplary apparatus 10A, source 12 is disposed in a toroidal housing 26. A mechanism 27 permits source 12 to be moved around housing 26 to irradiate a subject S from different sides. Subject S is on a table 28 which can be advanced through a central aperture 29 in housing 26. Apparatus having configurations like that shown schematically in FIG. 1A are used to deliver radiation in a manner commonly called "Tomotherapy".

In accordance with particular embodiments of the invention, beam positioning mechanism 13 causes source 12 and/or beam 14 to move along a trajectory while radiation dose is controllably delivered to target regions within subject S. A "trajectory" is a set of one or more movements of one or more of the movable parts of beam position mechanism 13 that results in the beam position and orientation changing from a first position and orientation to a second position and orientation. The first and second positions and the first and second orientations are not necessarily different. For example, a trajectory may be specified to be a rotation of gantry 16 from a starting point through an angle of 360° about axis 18 to an ending point in which case the beam position and orientation at the starting and ending points are the same.

The first and second beam positions and beam orientations may be specified by a first set of motion axis positions (corresponding to the first beam position and the first beam orientation) and a second set of motion axis positions (corresponding to the second beam position and the second beam orientation). As discussed above, control system 23 of radiation delivery apparatus 10 can controllably move its motion axes between the first set of motion axis positions and the second set of motion axis positions. In general, a trajectory may be described by more than two beam positions and beam orientations. For example, a trajectory may be specified by a plurality of sets of motion axis positions, each set of motion axis positions corresponding to a particular beam position and a particular beam orientation. Control system 23 can then controllably move its motion axes between each set of motion axis positions.

In general, a trajectory may be arbitrary and is only limited by the particular radiation delivery apparatus and its particular beam positioning mechanism. Within constraints imposed by the design of a particular radiation delivery apparatus 10 and its beam positioning mechanism 13, source 12 and/or beam 14 may be caused to follow an arbitrary trajectory relative to subject S by causing appropriate combinations of movements of the available motion axes. A trajectory may be specified to achieve a variety of treatment objectives. For example, a trajectory may be selected to have a high ratio of target tissue within the beam's eye view compared to healthy tissue within the beam's eye view or to avoid important healthy organs or the like.

For the purpose of implementing the present invention, it is useful to discretize a desired trajectory into a number of "control points" at various locations along the trajectory. A set of motion axis positions can be associated with each such control point. A desired trajectory may define a set of available control points. One way to specify a trajectory of radiation source 12 and/or beam 14 is to specify at a set of discrete control points at which the position of each motion axis is defined.

FIG. 2 schematically depicts a radiation source 12 traveling relative to a subject S along an arbitrary trajectory 30 in three-dimensions while delivering radiation dose to a subject S by way of a radiation beam 14. The position and orientation of radiation beam 14 changes as source 12 moves along

trajectory 30. In some embodiments, the changes in position and/or direction of beam 14 may occur substantially continuously as source 12 moves along trajectory 30. While source 12 is moving along trajectory 30, radiation dose may be provided to subject S continuously (i.e. at all times during the movement of source 12 along trajectory 30) or intermittently (i.e. radiation may be blocked or turned off at some times during the movement of source 12 along trajectory 30). Source 12 may move continuously along trajectory 30 or may move intermittently between various positions on trajectory 30. FIG. 2 schematically depicts a number of control points 32 along trajectory 30. In some embodiments, the specification of trajectory 30 defines the set of available control points 32. In other embodiments, the set of control points 32 are used to define trajectory 30. In such embodiments, the portions of trajectory 30 between control points 32 may be determined (e.g. by control system 23) from control points 32 by a suitable algorithm.

In general, control points 32 may be specified anywhere along trajectory 30, although it is preferable that there is a control point at the start of trajectory 30, a control point at the end of trajectory 30 and that the control points 32 are otherwise spaced-apart along trajectory 30. In some embodiments of the invention, control points 32 are selected such that the magnitudes of the changes in the position of a motion axis over a trajectory 30 are equal as between control points 32. For example, where a trajectory 30 is defined as a 360° arc of gantry 16 about axis 18 and where the number of control points 32 along trajectory 30 is 21, then control points 32 may be selected to correspond to 0° (a starting control point), 360° (an ending control point) and 19 other control points at 18° intervals along the arc of gantry 16.

Although trajectory 30 may be defined arbitrarily, it is preferable that source 12 and/or beam 14 not have to move back and forth along the same path. Accordingly, in some embodiments, trajectory 30 is specified such that it does not overlap itself (except possibly at the beginning and end of trajectory 30). In such embodiments, the positions of the motion axes of the radiation delivery apparatus are not the same except possibly at the beginning and end of trajectory 30. In such embodiments, treatment time can be minimized (or at least reduced) by irradiating subject S only once from each set of motion axis positions.

In some embodiments, trajectory 30 is selected such that the motion axes of the radiation delivery device move in one direction without having to reverse directions (i.e. without source 12 and/or beam 14 having to be moved back and forth along the same path). Selection of a trajectory 30 involving movement of the motion axes in a single direction can minimize wear on the components of a radiation delivery apparatus. For example, in apparatus 10, it is preferable to move gantry 16 in one direction, because gantry 16 may be relatively massive (e.g. greater than 1 ton) and reversing the motion of gantry 16 at various locations over a trajectory may cause strain on the components of radiation delivery apparatus 16 (e.g. on the drive train associated with the motion of gantry 16).

In some embodiments, trajectory 30 is selected such that the motion axes of the radiation delivery apparatus move substantially continuously (i.e. without stopping). Substantially continuous movement of the motion axes over a trajectory 30 is typically preferable to discontinuous movement, because stopping and starting motion axes can cause wear on the components of a radiation delivery apparatus. In other embodiments, the motion axes of a radiation delivery apparatus are permitted to stop at one or more locations along trajectory 30. Multiple control points 32 may be provided at

such locations to allow the beam shape and/or beam intensity to be varied while the position and orientation of the beam is maintained constant.

In some embodiments, trajectory 30 comprises a single, one-way, continuous 360° rotation of gantry 16 about axis 18 such that trajectory 30 only possibly overlaps itself at its beginning and end points. In some embodiments, this single, one-way, continuous 360° rotation of gantry 16 about axis 18 is coupled with corresponding one-way, continuous translational or rotational movement of couch 15, such that trajectory 30 is completely non-overlapping.

Some embodiments involve trajectories 30 which are effected by any combination of motion axes of radiation delivery apparatus 10 such that relative movement between source 12 and/or beam 13 and subject S comprises a discrete plurality of arcs, wherein each arc is confined to a corresponding plane (e.g. a rotation of up to 360° of gantry 16 about axis 18). In some embodiments, each arc may be non-self overlapping. In some embodiments, each arc may overlap only at its beginning and end points. In the course of following such a trajectory 30, the motion axes of radiation delivery apparatus 10 may be moved between individual arcs such that the corresponding planes to which the arcs are confined intersect with one another (e.g. by suitable rotation of couch 15 about axis 22). Alternatively, the motion axes of radiation delivery apparatus 10 may be moved between individual arcs such that the corresponding planes to which the arcs are defined are parallel with one another (e.g. by suitable translational movement of couch 15). In some cases, radiation may not be delivered to subject S when the motion axes of radiation delivery apparatus 10 are moved between individual arcs.

Radiation delivery apparatus, such as exemplary apparatus 10 (FIG. 1) and 10A (FIG. 1A), typically include adjustable beam-shaping mechanisms 33 located between source 12 and subject S for shaping radiation beam 14. FIG. 3A schematically depicts a beam-shaping mechanism 33 located between source 12 and subject S. Beam-shaping mechanism 33 may comprise stationary and/or movable metal components 31. Components 31 may define an aperture 31A through which portions of radiation beam 14 can pass. Aperture 31A of beam-shaping mechanism 33 may define a two-dimensional border of radiation beam 14. In particular embodiments, beam shaping mechanism 33 is located and/or shaped such that aperture 31A is in a plane orthogonal to the direction of radiation from source 12 to the target volume in subject S. Control system 23 is preferably capable of controlling the configuration of beam-shaping mechanism 33.

One non-limiting example of an adjustable beam-shaping mechanism 33 comprises a multi-leaf collimator (MLC) 35 located between source 12 and subject S. FIG. 3B schematically depicts a suitable MLC 35. As shown in FIG. 3B, MLC 35 comprises a number of leaves 36 that can be independently translated into or out of the radiation field to define one or more apertures 38 through which radiation can pass. Leaves 36, which may comprise metal components, function to block radiation. In the illustrated embodiment, leaves 36 are translatable in the leaf-translation directions indicated by double-headed arrow 41. Leaf-translation directions 41 may be located in a plane that is orthogonal to beam axis 37 (i.e. a direction of the radiation beam 14 from source 12 to the target volume in subject S). In the FIG. 3B view, beam axis 37 extends into and out of the page. The size(s) and shape(s) of aperture(s) 38 may be adjusted by selectively positioning each leaf 36.

As shown in the illustrate embodiment of FIG. 3B, leaves 36 are typically provided in opposing pairs. MLC 35 may be mounted so that it can be rotated to different orientations

about beam axis 37—i.e. such that leaf-translation directions 41 and the direction of movement of leaves 36 may be pivoted about beam axis 37. Dotted outline 39 of FIG. 3B shows an example of an alternate orientation of MLC 35 wherein MLC 35 has been rotated about beam axis 37 such that leaf-trans-

lation directions 41 are oriented at an angle that is approximately 45° from the orientation shown in the main FIG. 3B illustration.

It will be appreciated that the angle ϕ of leaf-translation directions 41 about beam axis 37 may be defined relative to an arbitrary reference axis. FIG. 3C schematically depicts a system for defining the angle ϕ of leaf-translation directions 41 about beam axis 37. In the FIG. 3C, the angle ϕ of leaf-translation directions 41 about beam axis 37 is defined to be an angle in a range of $-90^\circ < \phi \leq 90^\circ$ relative to a reference axis 43. FIG. 3C illustrates a first leaf-translation direction 41A wherein the angle ϕ_A is greater than zero and a second leaf-translation direction 41B wherein the angle ϕ_B is less than zero. The angle ϕ of leaf-translation directions 41 about beam axis 37 (as defined relative to reference axis 43 in the above-described manner) may be referred to as the MLC orientation angle ϕ . In particular embodiments, the reference axis 43 may be selected to coincide with the direction of motion of beam axis 37 as beam positioning mechanism 13 moves source 12 and/or beam 14 relative to subject S along trajectory 30. Reference axis 43 may therefore be referred to herein as source trajectory direction 43.

A configuration of MLC 35 can be specified by a set of leaf positions that define a position of each leaf 36 and an MLC orientation angle ϕ of MLC 35 about beam axis 37. The control system of a radiation delivery device (e.g. control system 23 of radiation delivery device 10) is typically capable of controlling the positions of leaves 36 and the MLC orientation angle ϕ . MLCs can differ in design details, such as the number of leaves 36, the widths of leaves 36, the shapes of the ends and edges of leaves 36, the range of positions that any leaf 36 can have, constraints on the position of one leaf 36 imposed by the positions of other leaves 36, the mechanical design of the MLC, and the like. The invention described herein should be understood to accommodate any type of configurable beam-shaping apparatus 33 including MLCs having these and other design variations.

The configuration of MLC 35 may be changed (for example, by moving leaves 36 and/or rotating the MLC orientation angle ϕ of MLC 35 about beam axis 37) while radiation source 12 is operating and while radiation source 12 is moving about trajectory 30, thereby allowing the shape of aperture(s) 38 to be varied dynamically while radiation is being delivered to a target volume in subject S. Since MLC 35 can have a large number of leaves 36, each of leaves 36 can be placed in a large number of positions and MLC 35 can be rotated about beam axis 37, MLC 35 may have a very large number of possible configurations.

FIG. 4A schematically depicts a method 50 according to an example embodiment of this invention. An objective of method 50 is to establish a radiation treatment plan that will deliver a desired radiation dose distribution to a target volume in a subject S (to within an acceptable tolerance), while minimizing the dose of radiation delivered to tissues surrounding the target volume or at least keeping the dose delivered to surrounding tissues below an acceptable threshold. This objective may be achieved by varying: (i) a cross-sectional shape of a radiation beam (e.g. beam 14); and (ii) an intensity of the radiation beam, while moving radiation source 12 and/or beam 14 along a trajectory 30 relative to subject S. In some embodiments, as discussed above, these objectives are

achieved while radiation source 12 and/or beam 14 are caused to move continuously along trajectory 30.

Method 50 may be performed, at least in part, by a treatment planning system 25 (e.g. treatment planning system 25 of FIG. 1). In the illustrated embodiment, treatment planning system 25 comprises its own controller 25A which is configured to execute suitable software 25B. In other embodiments, control system 23 and treatment planning system 25 may share a controller. Controller 25 may comprise one or more data processors, together with suitable hardware, including, by way of non-limiting example: accessible memory, logic circuitry, drivers, amplifiers, A/D and D/A converters and like. Such a controller may comprise, without limitation, a microprocessor, a computer-on-a-chip, the CPU of a computer or any other suitable microcontroller. Controller 25 may comprise a plurality of data processors.

A desired amount of radiation dose to be delivered to the target volume (referred to as the “desired dose distribution”) and a suitable trajectory 30 may be defined in advance. Method 50 derives the shape that beam 14 ought to have during movement of source 12 and/or beam 14 along trajectory 30 and the intensity with which radiation ought to be delivered during movement of source 12 and/or beam 14 along trajectory 30. The shape of beam 14 may be determined by a suitable configuration of a beam-shaping mechanism 33, such as MLC 35.

In block 52, method 50 obtains a set of optimization goals 61 and trajectory data 62 defining a desired trajectory 30. Optimization goals 61 comprise dose distribution data 60, which defines a desired dose distribution, and may comprise other optimization goals 63. Optimization goals 61 and/or trajectory data 62 may have been developed by health professionals, such as a radiation oncologist in consultation with a radiation physicist, for example. Optimization goals 61 and/or trajectory data 62 may be specified by an operator as a part of block 52.

The person or persons who develop trajectory 30 may have reference to factors such as:

- the condition to be treated;
- the shape, size and location of the target volume;
- the locations of critical structures that should be spared;
- and
- other appropriate factors.

Trajectory 30 may be selected to minimize treatment time.

Radiation delivery apparatus according to some embodiments of the invention may provide one or more pre-defined trajectories. For example, in some embodiments, a pre-defined trajectory 30 may comprise a single, one-way, continuous 360° rotation of gantry 16 about axis 18 such that trajectory 30 overlaps itself only at its beginning and end points. In such cases, block 52 may comprise selecting a pre-defined trajectory 30 or a template that partially defines a trajectory 30 and can be completed to fully define the trajectory 30.

As discussed above, optimization goals 61 comprise dose distribution data 60 and may comprise other optimization goals 63. Other optimization goals 63 may be specified by an operator as a part of block 52. By way of non-limiting example, other optimization goals 63 may comprise a desired uniformity of dose distribution in the target volume (or a desired precision with which the dose distribution in the target volume should match desired dose distribution data 60). Other optimization goals 63 may also define volumes occupied by important structures outside of the target volume and set limits on the radiation doses to be delivered to those structures. Other optimization goals 63 may define a maximum time required to deliver the radiation based on an individual patient’s ability to stay still during treatment. For

11

example, a child may be more likely to move during treatment than an adult and such movement may cause incorrect dose delivery. Consequently, it may be desirable to lower the maximum dose delivery time for the child to minimize the risk that the child may move during treatment. Other optimization goals **63** may also set priorities (weights) for different optimization goals.

Other optimization goals **63** may have any of a variety of different forms. For example, a biological model may be used in the computation of a metric which estimates a probability that a specified dose distribution will control a disease from which the subject is suffering and/or the probability that a specified dose delivered to non-diseased tissue may cause complications. Such biological models are known as radiobiological models. Other optimization goals **63** may be based in part on one or more radiobiological models. The physical limitations of a particular radiation delivery apparatus may also be taken into account as another example of an optimization goal **63**. As mentioned above, gantry **12** can be relatively massive and controlled movement of gantry **12** may be difficult and may cause strain to various components of the radiation delivery apparatus. As a particular example, one optimization goal **63** may be to have gantry **16** move continuously (i.e. without stopping) over the specified trajectory **30**.

Method **50** then proceeds to an optimization process **54**, which seeks desirable beam shapes and intensities as a function of the position of source **12** and/or beam **14** along trajectory **30**. In the illustrated embodiment of method **50**, optimization process **54** involves iteratively selecting and modifying one or more optimization variables affecting the beam shape or the beam intensity. For example, the optimization variable(s) may comprise a position of a leaf **36** in a MLC **35** at a control point **32** (which determines a shape of beam **14**), a MLC orientation angle ϕ of MLC **35** about axis **37** at a control point **32** (which determines a shape of beam **14**) and/or an intensity of beam **14** at a control point **32**. The quality of the dose distribution resulting from the modified optimization variable(s) is evaluated in relation to a set of one or more optimization goals. The modification is then accepted or rejected. Optimization process **54** continues until it achieves an acceptable set of beam shapes and intensities or fails.

In the illustrated method **50**, optimization process **54** begins in block **56** by establishing an optimization function. The block **56** optimization function is based, at least in part, on optimization goals **61**. The set of optimization goals **61** includes the desired dose distribution data **60** and may include one or more other optimization goals **63**. The block **56** optimization function may comprise a cost function. Higher costs (corresponding to circumstances which are farther from optimization goals **61**) may be associated with factors such as:

- deviations from the desired dose distribution data **60**;
- increases in the radiation dose delivered outside of the target volume;
- increases in the radiation dose delivered to critical structures outside of the treatment volume;
- increases in the time required to deliver the radiation treatment; and/or
- increases in the total radiation output required for the delivery of the treatment.

Lower costs (corresponding to circumstances which are closer to optimization goals **61**) may be associated with factors such as:

- radiation doses that come closer to matching specified thresholds (which may be related to desired dose distribution data **60**);
- no radiation doses exceeding specified thresholds;

12

- reductions in radiation dose outside of the target volume;
- reductions in radiation dose delivered to critical structures outside of the target volume;
- decreases in the time required to deliver the radiation treatment; and/or
- decreases in the total radiation output required for the delivery of the treatment.

These factors may be weighted differently from one another. Other factors may also be taken into account when establishing the block **56** optimization function.

The result of block **56** is an optimization function which takes as input a dose distribution and produces an output having a value or values that indicate how closely the input dose distribution satisfies a set of optimization goals **61**.

Block **58** involves initializing beam shapes and intensities for a number of control points **32** along trajectory **30**. The initial beam shapes and intensities may be selected using any of a wide variety of techniques. Initial beam shapes may be selected by specifying a particular configuration of MLC **35**. By way of non-limiting example, initial beam shapes specified in block **58** may be selected by any of:

- setting the beam shape at each control point **32** along trajectory **30** to approximate a beam's eye view outline of the target volume (taken from control point **32**);
- setting the beam shape so that radiation is blocked from healthy tissue structures only;
- initializing leaves **36** of MLC to be in a specified configuration such as fully open, fully closed, half-open, or defining a shape for aperture **38** (e.g. round, elliptical, rectangular or the like); and
- randomizing the positions of leaves **36** of MLC.

The particular way that the beam shapes are initialized is not critical and is limited only by the beam-shaping mechanism **33** of particular radiation delivery apparatus.

By way of non-limiting example, the initial beam intensities specified in block **58** may be selected by any of:

- setting all intensities to zero;
- setting all intensities to the same value; and
- setting intensities to random values.

In some embodiments, the beam shapes are initialized in block **58** to shapes that match a projection of the target (e.g. to approximate a beam's eye view outline of the target volume from each control point **32** along trajectory **30**) and the intensities are initialized in block **58** to all have the same value which may be set so that the mean dose in the target volume will equal a prescribed dose.

In block **64**, method **50** involves simulating the dose distribution resulting from the initial beam shapes and initial beam intensities. Typically, the block **64** simulation comprises a simulated dose distribution computation which is discussed in more detail below. Method **50** then determines an initial optimization result in block **65**. The block **65** determination of the initial optimization result may comprise evaluating the block **56** optimization function on the basis of the block **64** simulated dose distribution.

In block **66**, method **50** alters the beam shapes and/or intensities at one or more control points **32**. The block **66** alteration of beam shapes and/or intensities may be quasi-random. The block **66** alteration of beam shapes and/or intensities may be subject to constraints. For example, such constraints may prohibit impossible beam shapes and/or intensities and may set other restrictions on beam shapes, beam intensities and/or the rate of change of beam shapes and/or beam intensities. In each execution of block **66**, the alteration of beam shapes and/or intensities may involve a single parameter variation or multiple parameter variations to beam shape parameter(s) and/or to beam intensity para-

meter(s). The block 66 alteration of beam shapes and/or intensities and may involve variation(s) of these parameter(s) at a single control point 32 or at multiple control points 32. Block 68 involves simulating a dose distribution that would be achieved if the block 66 altered beam shapes and/or intensities were used to provide a radiation treatment. Typically, the block 68 simulation comprises a simulated dose distribution computation which is discussed in more detail below.

In some embodiments, the block 66 alteration of beam shapes and/or intensities is not chosen randomly, but rather is selected to give priority to certain parameter(s) that have large impacts on dose distribution quality. "Dose distribution quality" may comprise a reflection of how closely a simulated dose distribution calculation meets optimization goals 61. For example, where the beam is shaped by a MLC 35, certain leaves 36 or positions of leaves 36 may be given priority for modification. This may be done by determining a priori which leaves of MLC 35 have the most impact on dose distribution quality. Such an a priori determination of particularly important MLC leaves may be based, for example, on a calculation of the relative contributions to the block 56 optimization function from each voxel in the target region and the surrounding tissue and by a projection of beam ray lines intersecting a particular voxel to the plane of MLC 35.

In block 70, method 50 determines a current optimization result. The block 70 determination may comprise evaluating the block 56 optimization function on the basis of the block 68 simulated dose distribution. In block 72, the current optimization result (determined in block 70) is compared to a previous optimization result and a decision is made whether to keep or discard the block 66 alteration. The first time that method 50 arrives at block 72, the previous optimization result may be the block 65 initial optimization result. The block 72 decision may involve:

- (i) deciding to preserve the block 66 alteration (block 72 YES output) if the current optimization result is closer to optimization goals 61 than the previous optimization result; or
- (ii) deciding to reject the block 66 alteration (block 72 NO output) if the current optimization result is further from optimization goals 61 than the previous optimization result.

Other optimization algorithms may make the block 72 decision as to whether to keep or discard the block 66 alteration based on rules associated with the particular optimization algorithm. For example, such optimization algorithms may, in some instances, allow preservation of the block 66 alteration (block 72 YES output) if the current optimization result is further from the optimization goals 61 than the previous optimization result. Simulated annealing is an example of such an optimization algorithm.

If block 72 determines that the block 66 alteration should be preserved (block 72 YES output), then method 50 proceeds to block 73, where the block 66 altered beam shapes and intensities are updated to be the current beam shapes and intensities. After updating the beam shapes and intensities in block 73, method 50 proceeds to block 74. If block 72 determines that the block 66 alteration should be rejected (block 72 NO output), then method 50 proceeds directly to block 74 (i.e. without adopting the block 66 alterations).

Block 74 involves a determination of whether applicable termination criteria have been met. If the termination criteria have been met (block 74 YES output), method 50 proceeds to block 75, where the current beam shapes and intensities are saved as an optimization result. After block 75, optimization process 54 terminates. On the other hand, if the termination

criteria have not been met (block 74 NO output), method 50 loops back to perform another iteration of blocks 66 through 74.

By way of non-limiting example, block 74 termination criteria may include any one or more of:

- successful achievement of optimization goals 61;
- successive iterations not yielding optimization results that approach optimization goals 61;
- number of successful iterations of blocks 66 through 74 (where a successful iteration is an iteration where the block 66 variation is kept in block 73 (i.e. block 72 YES output));
- operator termination of the optimization process.

The illustrated method 50 represents a very simple optimization process 54. Optimization process 54 may additionally or alternatively include other known optimization techniques such as:

- simulated annealing;
- gradient-based techniques;
- genetic algorithms;
- applying neural networks; or
- the like.

Method 50 may be used as a part of an overall method for planning and delivering radiation dose to a subject S. FIG. 4B schematically depicts a method 300 for planning and delivering radiation dose to a subject S according to a particular embodiment of the invention. Method 300 begins in block 310, which, in the illustrated embodiment, involves obtaining a desired trajectory 30 and desired optimization goals 61. Method 300 then proceeds to block 320 which involves optimizing a set of radiation delivery parameters. In one particular embodiment, the block 320 optimization process may comprise an optimization of the beam shape and beam intensity parameters in accordance with optimization process 54 of method 50. The result of the block 320 optimization process is a radiation delivery plan. In block 330, the radiation delivery plan is provided to the control system of a radiation delivery apparatus (e.g. control system 23 of radiation delivery device 10 (FIG. 1)). In block 340, the radiation delivery apparatus delivers the radiation to a subject in accordance with the radiation treatment plan developed in block 320.

Method 50 involves the simulation of dose distribution that results from a particular set of beam shapes, beam intensities and motion axis positions (e.g. in blocks 64 and 68). Simulation of the dose distribution may be performed in any suitable manner. Some examples of dose calculation methods that may be employed to simulate dose distribution results comprise:

- pencil beam superposition;
- collapsed cone convolution; and
- Monte Carlo simulation.

In some embodiments, the dose that would be delivered by a treatment plan is simulated (as in blocks 64 and 68 of method 50) by adding a contribution to the dose from each control point 32. At each of control points 32, the following information is known:

- a position of source 12 and an orientation of beam 14 relative to subject S including the target volume (as determined by the positions of the available motion axes);
- a beam shape (as determined, for example, by a MLC orientation angle ϕ and/or a configuration of the leaves 36 of a MLC 35); and
- a beam intensity.

In some embodiments, the contribution to the dose at each control point 32 is determined by pencil beam superposition. Pencil beam superposition involves conceptually dividing the

projected area of beam **14** into many small beams known as “beamlets” or “pencil beams”. This may be done by dividing a cross-sectional beam shape (e.g. aperture **38** of MLC **35**) into a grid of square beamlets. The contribution to an overall dose distribution from a particular control point **32** may be determined by summing the contributions of the beamlets. The contribution to a dose distribution by individual beamlets may be computed in advance. Such contributions typically take into account radiation scattering and other effects that can result in the radiation from one beamlet contributing to dose in regions that are outside of the beamlet. In a typical MLC **35**, there is some transmission of radiation through leaves **36**. Consequently, when performing a dose simulation calculation, it is often desirable add some smaller contribution to the dose from outside of the beam shaping aperture **38** to account for transmission through leaves **36** of MLC **35**.

FIG. **5A** shows an aperture **38** of an MLC **35** divided into a plurality of beamlets **80**. In general, it is desirable for beamlets **80** to be fairly small to permit precise modelling of the wide range of configurations that aperture **38** may have. Beamlets **80** may be smaller than the widths of the leaves **36** (not shown in FIG. **5A**) of MLC **35**. In FIG. **5A**, 105 beamlets **80** are required to cover aperture **38** and, consequently, for a particular control point **32** having the aperture configuration shown in FIG. **5A**, a dose simulation calculation (e.g. a portion of the block **68** dose simulation) involves a superposition of the dose contributed by 105 beamlets **80**.

Some embodiments achieve efficiencies in this dose simulation computation by providing composite beamlets **82** that are larger than beamlets **80**. A range of composite beamlets **82** having different sizes, shapes and/or orientations may be provided. FIG. **5B** shows a number of composite beamlets **82A**, **82B**, **82C** (collectively, beamlets **82**) having different sizes and shapes. It can be seen from FIG. **5B**, that composite beamlets **82** can be used in the place of a plurality of conventionally sized beamlets **80**. An example application of composite beamlets **82** is shown in FIG. **5C**. For a given shape of aperture **38**, composite beamlets **82** are used in place of some or all of smaller beamlets **80**. In the particular configuration of aperture **38** of FIG. **5C** (which is the same as the configuration of aperture **38** of FIG. **5A**), the area of aperture **38** is covered by 28 composite beamlets **82** (24 **82A**, one **84B**, three **84C**) and one smaller beamlet **80**. Consequently, for a particular control point **32** having the aperture configuration of FIG. **5B**, a dose simulation calculation (e.g. a portion of the block **68** dose simulation) is reduced to a superposition of the dose contributed by 29 beamlets **82**, **80**. Dose contributed by composite beamlets **82** may be determined in advance in a manner similar to the advance dose contribution from conventional beamlets **80**.

The size and shape of composite beamlets **82** may be selected to reduce, and preferably minimize, the number of beamlets required to cover the area of aperture **38**. This can significantly reduce calculation time without significantly reducing the accuracy of dose simulation. The use of composite beamlets is not limited to pencil beam superposition and may be used in other dose simulation calculation algorithms, such as Monte Carlo dose simulation and collapsed cone convolution dose simulation, for example.

The use of composite beamlets **82** to perform a dose simulation calculation assumes that there are only small changes in the characteristics of the tissue over the cross-sectional dimension of the composite beamlet **82**. As composite beamlets are made larger, this assumption may not necessarily hold. Accordingly, the upper size limit of composite beamlets **82** is limited by the necessary calculation accuracy. In some embodiments, at least one dimension of composite beamlets

82 is greater than the largest dimension of conventional beamlet **80**. In some embodiments, the maximum dimension of composite beamlets **82** is less than 25 times the size of the largest dimension of conventional beamlet **80**.

The dose simulation computation (e.g. the block **68** dose simulation) is performed at a number of control points **32**. Based on calculations for those control points **32**, an estimated dose distribution is generated for a radiation source **12** that may be continuously moving over a trajectory **30** and continuously emitting a radiation beam **14**, where the radiation beam **14** may have a continuously varying shape and intensity. Where a dose distribution is computed by summing contributions from discrete control points **32**, the accuracy with which the computed dose will match the actual dose delivered by continuous variation of the position of source **12**, the orientation of beam **14**, the beam shape and the beam intensity will depend in part upon the number of control points **32** used to perform the dose simulation computation. If there are only a few control points **32**, then it may not be possible to obtain accurate estimates of the delivered dose. The dose delivered by source **12** over a continuous trajectory **30** can be perfectly modelled by summing contributions from discrete control points **32** only at the limit where the number of control points **32** approaches infinity. Discretization of the dose simulation calculation using a finite number of control points **32** will therefore degrade the accuracy of the modelled dose distribution.

This concept is graphically illustrated in FIG. **6**, which plots the dose simulation error against the number of control points **32**. FIG. **6** clearly shows that where the dose simulation computation makes use of a large number of control points **32**, the resultant error (i.e. the difference between simulation dose distribution and actual dose distribution) is minimized.

In some embodiments of the invention, constraints are imposed on the optimization process (e.g. block **54** of method **50**). Such constraints may be used to help maintain the accuracy of the discretized dose simulation calculation to within a given tolerance. In some embodiments, these optimization constraints are related to the amount of change in one or more parameters that may be permitted between successive control points **32**. Examples of suitable constraints include:

Radiation source **12** cannot travel further than a maximum distance between consecutive control points **32**. This may be achieved entirely, or in part, by imposing a maximum change in any motion axis between consecutive control points **32**. Separate constraints may be provided for each motion axis. For example, a maximum angular change may be specified for gantry angle, maximum changes in displacement may be provided for couch translation etc.

Parameters affecting beam shape cannot change by more than specified amounts between consecutive control points **32**. For example, maximum values may be specified for changes in the positions of leaves **36** of a MLC **35** or changes in MLC orientation angle ϕ of MLC **35**.

Parameters affecting beam shape cannot change by more than a specified amount per unit of motion axis change. For example, maximum values may be specified for changes in the positions of leaves **36** of a MLC **35** for each degree of rotation of gantry **16** about axis **18**.

The source intensity cannot change by more than a specified amount between control points **32**.

The source intensity cannot change by more than a specified amount per unit of motion axis change.

The source intensity cannot exceed a certain level.

It will be appreciated that where a dose simulation calculation is based on a number of discretized control points, constraints

which force small changes of motion axes parameters, beam shape parameters and/or beam intensity parameters between control points can produce more accurate dose simulation calculations.

In addition to improving the accuracy of the dose simulation calculation, the imposition of constraints may also help to reduce total treatment time by accounting for the physical limitations of particular radiation delivery apparatus. For example, if a particular radiation delivery apparatus has a maximum radiation output rate and the optimization solution generated by method 50 involves a desired radiation intensity that results in a radiation output rate higher than this maximum radiation output rate, then the rate of movement of the motion axes of the radiation delivery apparatus will have to slow down in order to deliver the intensity prescribed by the block 54 optimization process. Accordingly, a constraint imposed on the maximum source intensity during the block 54 optimization can force a solution where the prescribed intensity is within the capability of the radiation delivery apparatus (e.g. less than the maximum radiation output rate of the radiation delivery apparatus) such that the motion axes of the radiation delivery apparatus do not have to slow down. Since the motion axes do not have to slow down, such a solution can be delivered to subject S relatively quickly, causing a corresponding reduction in total treatment time. Those skilled in the art will appreciate that other constraints may be used to account for other limitations of particular radiation delivery apparatus and can be used to reduce total treatment time.

An example of how such constraints may be defined is “For an estimated dose to be within 2% of the actual dose distribution, the following parameters should not change by more than the stated amounts between any two consecutive control points 32:

intensity—10%;
MLC leaf position—5 mm;
MLC orientation ϕ —5%;
gantry angle—1 degree; and
couch position—3 mm”

The number of control points 32 used in optimization process 54 also impacts the number of iterations (and the corresponding time) required to implement optimization process 54 as well as the quality of the dose distribution. FIG. 7 graphically depicts the dose distribution quality as a function of the number of iterations involved in a block 54 optimization process for various numbers of control points 32.

FIG. 7 shows plots for 10 control points, 50 control points, 100 control points and 300 control points on a logarithmic scale. It will be appreciated by those skilled in the art that the number of iterations (the abscissa in FIG. 7) is positively correlated with the time associated to perform the optimization. FIG. 7 shows that when the number of control points 32 is relatively low, the quality of the dose distribution improves rapidly (i.e. over a relatively small number of iterations). However, when the number of control points 32 is relatively low, the quality of the resultant dose distribution is relatively poor and, in the cases of 10 control points and 50 control points, the quality of the dose distribution does not achieve the optimization goals 61. Conversely, if a relatively large number of control points 32 is used, the block 54 optimization requires a relatively large number of iterations, but the quality of the dose distribution eventually achieved is relatively high and exceeds the optimization goals 61. In some cases, where the number of control points 32 is relatively high, the number of iterations required to achieve a solution that meets the optimization goals 61 can be prohibitive (i.e. such a solution can take too long or can be too computationally expensive).

The impact of the number of control points 32 on the block 54 optimization process may be summarized as follows. If a relatively small number of control points 32 are used:

there may be relatively large changes in the motion axes parameters (i.e. beam position and beam orientation), the beam shape parameters (e.g. positions of leaves 36 of MLC 35 and/or MLC orientation angle ϕ) and beam intensity between control points 32 (i.e. the constraints on the motion axes parameters, the beam shape parameters and the beam intensity will be relatively relaxed as between control points 32);

because of the relatively relaxed constraints and the large range of permissible changes to the beam shape and intensity parameters, it is possible to explore a relatively large range of possible configurations of the beam intensity and beam shape during optimization process 54;

because of the ability to explore a relatively large range of possible beam shape and intensity configurations, the block 54 optimization process will tend to approach the optimization goals 61 after a relatively small number of iterations;

because there are fewer control points available at which the beam shape parameters and/or beam intensity parameters may be varied, it may be difficult or impossible for the block 54 optimization process to derive a dose distribution that meets or exceeds optimization goals 61; and

the accuracy of dose simulation computations based on the relatively small number of control points 32 will be relatively poor and may be outside of an acceptable range.

If a relatively large number of control points 32 are used: the possible magnitudes of the changes in the motion axes parameters (i.e. beam position and beam orientation), the beam shape parameters (e.g. positions of leaves 36 of MLC 35 and/or MLC orientation angle ϕ) and beam intensity between control points 32 are relatively low (i.e. the constraints on the motion axes parameters, the beam shape parameters and the beam intensity will be relatively restrictive as between control points 32);

because of the relatively restrictive constraints and the small range of permissible changes to the beam shape and intensity parameters, only a relatively small range of possible beam shape and beam intensity configurations may be explored during optimization process 54;

because of the limited range of possible beam shape and intensity configurations, it may take a relatively large number of iterations for the block 54 optimization process to approach the optimization goals 61;

because there are more control points available at which the beam shape and/or the beam intensity may be varied, it may be easier to derive a dose distribution that meets or exceeds optimization goals 61; and

the accuracy of dose simulation computations based on the relatively large number of control points 32 will be relatively good.

In some embodiments, the benefits of having a small number of control points 32 and the benefits of having a large number of control points 32 are achieved by starting the optimization process with a relatively small number of control points 32 and then, after a number of initial iterations, inserting additional control points 32 into the optimization process. This process is schematically depicted in FIG. 8.

FIG. 8 shows a method 150 of optimizing dose delivery according to another embodiment of the invention. Method 150 of FIG. 8 may be used as a part of block 320 in method 300 of FIG. 4B. In many respects, method 150 of FIG. 8 is

similar to method 50 of FIG. 4A. Method 150 comprises a number of functional blocks which are similar to those of method 50 and which are provided with reference numerals similar to the corresponding blocks of method 50, except that the reference numerals of method 150 are preceded by the numeral "1". Like method 50, the objective of method 150 is to establish a radiation treatment plan that will deliver a desired radiation dose distribution to a target volume in a subject S (to within an acceptable tolerance), while minimizing the dose of radiation delivered to tissues surrounding the target volume or at least keeping the dose delivered to surrounding tissues below an acceptable threshold. This objective may be achieved by varying: (i) a cross-sectional shape of radiation beam 14; and (ii) an intensity of beam 14, while moving radiation source 12 and/or beam 14 along a trajectory 30 relative to subject S.

The principal difference between method 50 of FIG. 4A and method 150 of FIG. 8 is that the optimization process 154 of method 150 involves a repetition of the optimization process over a number of levels. Each level is associated with a corresponding number of control points 32 and the number of control points 32 increases with each successive level. In the illustrated embodiment, the total number of levels used to perform the block 154 optimization (or, equivalently, the final number of control points 32 at the conclusion of the block 154 optimization process) may be determined prior to commencing method 150. For example, the final number of control points 32 may be specified by an operator depending, for example, on available time requirements, accuracy requirements and/or dose quality requirements. In other embodiments, depending on termination conditions explained in more detail below, the final number of control points 32 may vary for each implementation of method 150.

Method 150 starts in block 152 and proceeds in the same manner as method 50 until block 158. In the illustrated embodiment, block 158 differs from block 58 in that block 158 involves the additional initialization of a level counter. In other respects, block 158 is similar to block 58 of method 50. Initialization of the level counter may set the level counter to 1 for example. When the level counter is set to 1, method 150 selects a corresponding level 1 number of control points 32 to begin the block 154 optimization process. The level 1 number of control points 32 is preferably a relatively low number of control points. In some embodiments, the level 1 number of control points 32 is in a range of 2-50. As discussed in more detail below, the level counter is incremented during the implementation of method 150 and each time the level counter is incremented, the corresponding number of control points 32 is increased.

Using a number of control points 32 dictated by the level counter, method 150 proceeds with blocks 164 through 174 in a manner similar to blocks 64 through 74 of method 50 discussed above. Block 174 differs from block 74 in that block 174 involves an inquiry into the termination conditions for a particular level of method 150. The termination conditions for a particular level of method 150 may be similar to the termination conditions in block 74 of method 50. By way of non-limiting example, the termination conditions for block 174 may comprise any one or more of:

- successful achievement of optimization goals 61 to within a tolerance level which may be particular to the current level;
- successive iterations not yielding optimization results that approach optimization goals 61; and
- operator termination of the optimization process.

Additionally or alternatively, the block 174 termination conditions may include reaching a maximum number of itera-

tions of blocks 166 through 174 within a particular level of method 150 regardless of the resultant optimization quality. For example, the maximum number of iterations for level 1 may be 10^4 . The maximum number iterations may vary for each level. For example, the maximum number of iterations may increase for each level in conjunction with a corresponding increase in the number of control points 32 or may decrease for each level in conjunction with a corresponding increase in the number of control points 32.

Additionally or alternatively, the block 174 termination conditions may include reaching a maximum number of successful iterations of blocks 166 through 174 within a particular level of method 150 (i.e. iterations where method 150 proceeds through the block 172 YES output and the block 166 variation is kept in block 173). Again, the maximum number of successful iterations may vary (increase or decrease) for each level. In some embodiments, the maximum number of successful iterations within a particular level decreases as the level (i.e. the number of control points 32) increases. In one particular embodiment, the maximum number of successful iterations decreases exponentially as the level increases.

If the termination criteria have not been met (block 174 NO output), method 150 loops back to perform another iteration of blocks 166 through 174 at the current level. If the termination criteria have been met (block 174 YES output), method 150 proceeds to block 178, where method 150 inquires into the general termination conditions for optimization process 154. The general termination conditions of block 178 may be similar to the termination conditions in block 174, except the block 178 termination conditions pertain to optimization process 154 as a whole rather than to a particular level of optimization process 154. By way of non-limiting example, the termination conditions for block 178 may comprise any one or more of:

- successful achievement of optimization goals 61 to within a tolerance level particular to optimization process 154 as a whole;
- successive iterations not yielding optimization results that approach optimization goals 61; and
- operator termination of the optimization process.

Additionally or alternatively, the block 178 termination conditions may include reaching a suitable minimum number of control points 32. This minimum number of control points may depend on the number of control points 32 required to ensure that dose simulation calculations have sufficient accuracy (see FIG. 6).

The block 178 termination conditions may additionally or alternatively comprise having minimum threshold level(s) of control points 32 for corresponding changes in the motion axes parameters, the beam shape parameters and/or the beam intensity parameter. In one particular example, the block 178 termination conditions may comprise minimum threshold level(s) of at least one control point 32 for:

- each intensity change greater than 10%;
- each MLC leaf position change greater than 5 mm;
- each MLC orientation change greater than 5°;
- each gantry angle change greater than 1°; and/or
- each couch position change greater than -3 mm.

If the block 178 termination criteria have been met (block 178 YES output), method 150 proceeds to block 175, where the current beam shapes and intensities are saved as an optimization result. After block 175, method 150 terminates. On the other hand, if the block 178 termination criteria have not been met (block 178 NO output), method 150 proceeds to block 180, where the number of control points 32 is increased.

The addition of new control points 32 in block 180 may occur using a wide variety of techniques. In one particular

embodiment, new control points **32** are added between pairs of existing control points **32**. In addition to adding new control points **32**, block **180** comprises initializing the parameter values associated with the newly added control points **32**. For each newly added control point **32**, such initialized parameter values may include: motion axes parameters which specify the position of source **12** and the orientation of beam **14** (i.e. the set of motion axis positions corresponding to the newly added control point **32**); an initial beam shape parameter (e.g. the configuration of the leaves **36** and/or orientation ϕ of a MLC **35**); and an initial beam intensity parameter.

The motion axes parameters corresponding to each newly added control point **32** may be determined by the previously specified trajectory **30** (e.g. by desired trajectory data **62**). The initial beam shape parameters and the initial beam intensity parameters corresponding to each newly added control point **32** may be determined by interpolating between the current beam shape parameters and current beam intensity parameters for previously existing control points **32** on either side of the newly added control point **32**. Such interpolation may comprise linear or non-linear interpolation for example.

The initial parameter values for the newly added control points **32** and the subsequent permissible variations of the parameter values for the newly added control points **32** may be subject to the same types of constraints discussed above for the original control points **32**. For example, the constraints on the parameter values for newly added control points **32** may include:

- constraints on the amount that radiation source **12** (or any one or more motion axes) can move between control points **32**;
- constraints on the amount that the beam shape can change between successive control points **32** (e.g. constraints on the maximum rotation MLC orientation ϕ or movement of the leaves **36** of MLC **35**); or
- constraints on the amount that the intensity of source **12** may change between successive control points **32**.

Those skilled in the art will appreciate that the magnitude of these optimization constraints will vary with the number of control points **32** and/or the separation of adjacent control points **32**. For example, if the constraint on a maximum movement of a leaf **36** of MLC **35** is 2 cm between successive control points **32** when there are 100 control points **32** and the number of control points **32** is doubled to 200, the constraint may be halved, so that the constraint on the maximum movement of a leaf **36** of MLC **35** is 1 cm between control points **32** (assuming that the newly added control points **32** are located halfway between the existing control points **32**).

After adding and initializing the new control points **32** in block **180**, method **180** proceeds to block **182** where the level counter **182** is incremented. Method **150** then returns to block **164**, where the iteration process of blocks **164** through **174** is repeated for the next level.

An example of the method **150** results are shown in FIG. **9**, which graphically depicts the dose distribution quality versus the number of iterations on a linear scale. FIG. **9** also shows that the number of control points **32** increases as the dose distribution gets closer to the optimization goals **61**. It can be seen that by starting the optimization process with a relatively low number of control points **32** and then adding additional control points **32** as the optimization process approaches the optimization goals **61**, the number of iterations required to achieve an acceptable solution has been dramatically reduced. FIG. **9** also shows that:

- the use of a small number of control points **32** at the beginning of the optimization process allows the opti-

mization to get close to optimization goals **61** after a relatively small number of iterations; the introduction of additional control points **32** during the course of the optimization allows the flexibility to derive a dose distribution that meets optimization goals **61**; and before the overall optimization process is terminated, a large number of control points **32** have been added and the parameters associated with these additional control points obey the associated optimization constraints, thereby preserving the dose calculation accuracy.

As with method **50** discussed above, method **150** describes a simple optimization process **154**. In other embodiments, the block **154** optimization process may additionally or alternatively include other known optimization techniques such as: simulated annealing, gradient-based techniques, genetic algorithms, applying neural networks or the like.

In method **150**, additional control points **32** are added when the level is incremented. In a different embodiment, the addition of one or more new control points may be treated as an alteration in block **66** of method **50**. In such an embodiment, the procedures of block **180** associated with the addition of control points **32** may be performed as a part of block **66**. In such an embodiment, the termination conditions of block **74** may also comprise an inquiry into whether the optimization has achieved a minimum number of control points **32**. In other respects, such an embodiment is similar to method **50**.

The result of optimization method **50** or optimization method **150** is a set of control points **32** and, for each control point **32**, a corresponding set of parameters which includes: motion axes parameters (e.g. a set of motion axis positions for a particular radiation delivery apparatus that specify a corresponding beam position and beam orientation); beam shape parameters (e.g. a configuration of an MLC **35** including a set of positions for leaves **36** and, optionally, an orientation angle ϕ of MLC **35** about axis **37**); and a beam intensity parameter. The set of control points **32** and their associated parameters form the basis of a radiation treatment plan which may then be transferred to a radiation delivery apparatus to effect the dose delivery.

The radiation intensity at a control point **32** is typically not delivered instantaneously to the subject but is delivered continuously throughout the portion of the trajectory **30** defined by that control point **32**. The radiation output rate of the source **12** may be adjusted by the radiation delivery apparatus **10** and control system **23** so that the total radiation output for that control point **32** is the same as the intensity determined from the radiation plan. The radiation output rate will normally be determined by the amount of time required for the position of the radiation source **12** and the shape of the radiation beam to change between the previous, current and following control points **32**.

A control system of the radiation delivery apparatus (e.g. control system **23** of radiation delivery apparatus **10**) uses the set of control points **32** and their associated parameters to move radiation source **12** over a trajectory **30** while delivering radiation dose to a subject **S**. While the radiation delivery apparatus is moving over trajectory **30**, the control system controls the speed and/or position of the motion axes, the shape of the beam and the beam intensity to reflect the motion axis parameters, beam shape parameters and the beam intensity parameters generated by the optimization methods **50**, **150**. It will be appreciated by those skilled in the art that the output of the optimization methods **50**, **150** described above may be used on a wide variety of radiation delivery apparatus.

Pseudocode for Exemplary Embodiment of Optimization Process

Pre-Optimization

Define 3-dimensional target and healthy tissue structures. 5
 Set optimization goals for all structures based on one or more of:
 Histograms of cumulative dose;
 Prescribed dose required to the target;
 Uniformity of dose to the target; 10
 Minimal dose to healthy tissue structures.
 Combine all optimization goals into a single quality factor (i.e. an optimization function).
 Define the trajectory for the radiation source:
 Select a finite number of control points; and
 Set the axis position for each axis at each control point. 15

Initialization

Configure MLC characteristics (e.g. leaf width, transmission).
 Initialize level counter and initial number of control points.
 Initialize MLC leaf positions to shape the beam to the outline of the target. 20
 Perform dose simulation calculation to simulate dose distribution for all targets and healthy tissue structures:
 Generate a random distribution of points in each target/structure;
 Calculate the dose contribution from each initial control point; and 25
 Add the contribution from each initial control point.
 Rescale the beam intensity and corresponding dose so that the mean dose to the target is the prescription dose. 30
 Set constraints for:
 maximum change in beam shape parameters (i.e. movement of MLC leaves and/or rotations of MLC); and
 maximum change in beam intensity;
 for corresponding variations the relevant motor axes, including, where relevant: 35
 Gantry angle;
 Couch angle;
 Couch position; and
 MLC orientation.
 Set maximum intensity constraint. 40
 Set maximum treatment time constraint.
 Set optimization parameters:
 Probability of adding control points;
 At each iteration:
 Probability of changing beam shape parameter (e.g. 45
 MLC leaf position or MLC orientation) taking into account constraints on range of changes in MLC leaf position; and
 Probability of changing a radiation intensity taking into account constraints on range of intensity 50
 changes.

Optimization

While the optimization goals have not been attained:
 1. Select a control point.
 2. Select a beam shape alteration, intensity alteration, or add 55
 control points.
 If a beam shape alteration (e.g. a change in position of an MLC leaf) is selected:
 Randomly select an MLC leaf to change;
 Randomly select a new MLC leaf position; 60
 Ensure that the new MLC leaf position does not violate any positional constraints:
 Leaf does not overlap with opposing leaf;
 Leaf does not move outside of the initialized aperture;
 and
 Leaf does not violate the maximum movement constraints. 65

Perform dose distribution simulation to calculate the new dose distribution for all structures.
 Calculate quality factor (i.e. optimization function) for new dose distribution.
 If the quality factor (i.e. optimization function) indicates an improvement, then accept the new leaf position.
 If an intensity alteration is selected:
 Randomly select a new intensity;
 Ensure that the new intensity does not violate any constraints:
 Intensity cannot be negative;
 Intensity cannot violate the maximum intensity constraint; and
 Intensity cannot violate the maximum intensity variation constraints.
 Perform dose distribution simulation to calculate the new dose distribution for all structures.
 Calculate quality factor (i.e. optimization function) for new dose distribution.
 If the quality factor (i.e. optimization function) indicates an improvement, then accept the new intensity.
 If adding control points is selected:
 Insert one or more control points within the existing trajectory.
 Adjust optimization constraints (e.g. beam shape constraints and intensity constraints) based on addition of new control points.
 Initialize beam shape parameters, intensity parameters and motion axes parameters of new control point(s).
 Perform dose distribution simulation (incorporating the new control points) to calculate the new dose distribution for all structures.
 Rescale all intensities so that the new intensities provide a mean dose to the target equal to the prescription dose.
 Continue optimization with the added control points.
 If the termination criteria have been attained:
 Terminate the optimization; and
 Record all optimized parameters (e.g. beam shape parameters, motion axes parameters and beam intensity parameters) and transfer optimized parameters to the radiation device.
 If the termination criteria has not be attained:
 Go to step (1) and select another beam shape alteration, intensity alteration, or add control points.

Example Implementation of a Particular Embodiment

The following represents an illustrative example implementation of a particular embodiment of the invention. FIG. 10 shows a three-dimensional example of target tissue 200 and healthy tissue 202 located within the body of a subject S. This example simulates a radiation delivery apparatus similar to radiation delivery apparatus 10 (FIG. 1).

In this example, a trajectory 30 is defined as a 360° rotation of gantry 16 about axis 18 and a movement of couch 15 in the -Z direction (as shown in the coordinate system of FIG. 10). While this particular example uses a trajectory 30 involving two motion axes, it will be appreciated that trajectory 30 may involve movement of fewer motion axes or a greater number of motion axes. FIGS. 11A and 11B respectively depict the initial control point 32 positions of the relevant motion axes

corresponding to the selected trajectory **30** (i.e. the angular positions of gantry **16** about axis **18** and the position of couch **15** in the Z dimension).

For this example, the optimization goals **61** included a desired dose distribution **60** having a uniform level of 70 Gy for target **200** and a maximum dose of 35 Gy for healthy tissue **202**. At each initial control point **32**, the beam shape parameters were initialized such that the leaves **36** of a MLC **35** shaped the beam into a beam's eye view outline of target **200**. In this example, the orientation ϕ of MLC **35** was maintained constant at 45° and the orientation ϕ of MLC **35** was not specifically optimized. At each initial control point **32**, the beam intensity was initialized so that the mean dose delivered to the target **200** was 70 Gy.

FIGS. **12A-F** graphically depict the simulated dose distribution calculation at various stages of the optimization process by way of a dose volume histogram (DVH). In FIGS. **12A-F**, dashed line **204** represents the percentage of the volume of healthy tissue **202** that receives a certain quantity of dose and the solid line **206** represents the percentage of the volume of target **200** that receives a certain quantity of dose. A DVH is a convenient graphical tool for evaluating dose distribution quality. It will be appreciated that movement of dashed line **204** downwardly and leftwardly represents a minimization of dose delivered to healthy tissue **202** and that movement of solid line **206** upwardly (as far as 100%) and rightwardly (as far as the dose distribution target (70 Gy in this example)) represents effective delivery of dose to target **200**.

In this example, the optimization process starts at zero iterations with the 12 control points depicted in FIGS. **11A** and **11B**. The result at zero iterations is shown in FIG. **12A**. In this example, the number of iterations and the number of control points are increased during the optimization process as shown in FIG. **12B-12F**. After 900 iterations and an increase to 23 control points (FIG. **12B**), a dramatic improvement in dose quality can be observed by the leftwardly and downwardly movement of dashed line **204**. Further improvement is seen at 1800 iterations and 45 control points (FIG. **12C**) and at 3200 iterations and 89 control points (FIG. **12D**). The magnitude of the improvement in dose distribution quality per iteration decreases as the optimization progresses. FIGS. **12D-12F** show that there is little improvement in the dose distribution quality between 3200 iterations and 89 control points (FIG. **12D**), 5800 iterations and 177 control points (FIG. **12E**) and 8500 iterations and 353 control points. As discussed above, notwithstanding the minimal improvement in dose distribution quality between FIGS. **12D** and **12F**, it can be useful to continue to increase the number of control points in the optimization to improve the accuracy of the dose simulation calculations.

FIG. **13** is another graphical representation of this example which shows how the optimization goals **61** are achieved (to within an acceptable tolerance level) after 5800 iterations (177 control points).

The optimization of this example was terminated after 11,000 iterations because the optimization goals had been attained (to within acceptable tolerances) and there was no further improvement in the dose distribution quality or accuracy with further iterations. The results of this example are shown in FIGS. **14A-14D**, which respectively depict the motion axes parameters at each of the final control points (in this case, the orientation of gantry **16** about axis **18** (FIG. **14A**) and the Z position of couch **15** (FIG. **14B**)), the radiation intensity at each of the final control points (FIG. **14C**) and the beam shaping parameters at each of the final control points (in this case, positions of two leaves **36** of an MLC **35** (FIG.

14D)). FIG. **14D** shows that there are no dramatic changes in position of the illustrated leaves **36** of MLC **3**, as constraints were applied to the allowable rate of change of the leaves **36** of MLC **35**.

FIG. **15** shows a two-dimensional cross-section of the optimized dose distribution. FIG. **15** shows plots contour lines of constant dose (isodose lines) indicating the regions of high and low dose. The amount of dose associated with each isodose line is enumerated on the line itself. Recalling the shape and relative position of the target **200** and healthy tissue **202** from FIG. **10**, FIG. **15** shows that the high dose region is confined to the c-shape target area **200** while inside the concavity (i.e. the region of healthy tissue **202**), the dose is significantly reduced.

In this example, the optimization time was 15.3 minutes. The treatment time required to deliver this dose distribution is approximately 1.7 minutes (assuming a dose rate of 600 MU/min).

In some embodiments, the methods described herein for delivering radiation dose to a subject S are used in conjunction with one or more imaging techniques and corresponding imaging apparatus. A suitable imaging technique is cone-beam computed tomography (cone-beam CT), which obtains a three-dimensional image of a subject. Cone-beam CT involves a radiation source and a corresponding sensor which can be suitably mounted on a radiation delivery apparatus. For example, a cone-beam CT radiation source may be mounted on gantry **16** of radiation delivery apparatus **10** and a corresponding sensor may be mounted on the opposing side of subject S to detect radiation transmitted through subject S. In some embodiments, the cone-beam CT source is the same as the treatment radiation source **12**. In other embodiments, the cone-beam CT source is different than the treatment radiation source **12**. The radiation delivery apparatus may move the cone-beam CT source and the CT sensor relative to subject S using the same motion axes (or substantially similar motion axes) used to move the treatment radiation source **12**. At any point in which the cone-beam CT source is activated, a 2-dimensional projection image is formed from the transmission of radiation emanating from the cone-beam CT source, passing through subject S and impinging onto the corresponding sensor (which typically comprises a 2-dimensional array of radiation sensors). In some embodiments, the cone-beam CT radiation source and the treatment radiation source are time division multiplexed, such that the cone-beam CT sensor can distinguish between imaging radiation and treatment radiation.

In the acquisition of a 3-dimensional cone-beam CT image, the cone-beam CT source and sensor array move through a trajectory to acquire a plurality of 2-dimensional projection images of subject S. The plurality of 2-dimensional projection images are combined using methods known to those skilled in the art in order to reconstruct the 3-dimensional image of subject S. The 3-dimensional image may contain spatial information of the target and healthy tissue.

In some embodiments, a cone-beam CT image of subject S is acquired while delivering radiation to the subject. The 2-dimensional images may be taken from around the same trajectory **30** and in the same time interval that the radiation is delivered to subject S. In such embodiments, the resultant cone-beam CT image will be representative of the subject position, including the 3-dimensional spatial distribution of target and healthy tissue, at the time the subject was treated. The spatial distribution of target and healthy tissue can be referenced to the particular radiation delivery apparatus,

allowing an observer to accurately assess what radiation dose distribution was actually delivered to the target and healthy tissue structures.

Subject S, and more particularly, the locations of target and healthy tissue, can move during radiation delivery. While some movement can be reduced or eliminated, one difficult movement to stop is respiration. For example, when subject S breathes, a target located inside the lung may shift as a function of the breathing cycle. In most dose simulation calculations, subject S is assumed to be stationary throughout the delivery. Accordingly, ordinary breathing by subject S can result in incorrect delivery of dose to the target and healthy tissue. In some embodiments, radiation source **12** is activated only when a position or configuration of subject S is within a specified range.

In some embodiments, one or more sensors are used to monitor the position of subject S. By way of non-limiting example, such sensors may include respirometer, infrared position sensors, electromyogram (EMG) sensors or the like. When the sensor(s) indicate that subject S is in an acceptable position range, radiation source **12** is activated, the configuration of beam-shaping mechanism **33** changes and the motion axes move as described in the radiation treatment plan. When the sensor(s) indicate that subject S is not in the acceptable position range, the radiation is deactivated, the configuration of beam-shaping mechanism **33** is fixed and the motion axes are stationary. An acceptable position range may be defined as a particular portion of the respiratory cycle of subject S. In such embodiments, the radiation treatment plan is delivered intermittently, with intervals where the radiation apparatus and radiation output are paused (i.e. when the subject is out of the acceptable position range) and intervals where the radiation apparatus and radiation output are resumed (i.e. when the subject is in the acceptable position range). Treatment delivery proceeds in this way until the treatment plan has been completely delivered. The process of position dependent delivery of radiation may be referred to as “position gating” of radiation delivery.

In one particular embodiment of the invention, cone-beam CT images are acquired while position gated treatment is being delivered to subject S. The acquisition of 2-dimensional projection images may also be gated to the patient position, so that the cone-beam CT images will represent the position of subject S at the time of treatment delivery. Such embodiments have the additional benefit that the 2-dimensional cone-beam CT images are obtained with subject S in a consistent spatial position, thereby providing a 3-dimensional cone-beam CT with fewer motion artifacts.

As discussed above, in some embodiments where beam-shaping mechanism **33** comprises a MLC **35**, it is possible to optimize beam-shape parameters including, without limitation: the positions of MLC leaves **36** and the corresponding shape of the MLC apertures **38**; and the MLC orientation angle ϕ about beam axis **37**. In other embodiments where beam-shaping mechanism **33** comprises a MLC **35**, it may be desired to maintain a constant MLC orientation angle ϕ about beam axis **37**—e.g. where a particular radiation delivery apparatus **10** does not permit adjustment of MLC orientation angle ϕ during delivery and/or where processing power used in the optimization process is at a premium.

Where MLC orientation angle ϕ is maintained constant, MLC **35** may have certain limitations in its ability to approximate arbitrary beam shapes. In such instances, the selection of the particular constant MLC orientation angle ϕ may impact treatment plan quality and ultimately the radiation dose that is delivered to subject S. An example of this scenario is illustrated schematically in FIGS. **16A** and **16B**, where it is

desired to provide a beam shape **301**. In the FIG. **16A** example, leaf-translation directions **41** are oriented substantially parallel with the motion of beam **14** along source trajectory direction **43** (i.e. MLC orientation angle $\phi=0^\circ$). In the FIG. **16B** example, leaf-translation directions **41** are oriented substantially orthogonally to the motion of beam **14** along source trajectory direction **43** (i.e. MLC orientation angle $\phi=90^\circ$). It can be seen by comparing FIGS. **16A** and **16B** that when $\phi=0^\circ$ (FIG. **16A**), the beam shape of MLC **35** does a relatively good job of approximating desired beam shape **301**, whereas when $\phi=90^\circ$ (FIG. **16B**), there are regions **303** where MLC does a relatively poor job of approximating desired beam shape **301**.

While not explicitly shown in FIGS. **16A** and **16B**, it will be understood that if desired beam shape **301** was rotated 90° from the orientation shown in FIGS. **16A** and **16B**, then the MLC orientation angle $\phi=90^\circ$ would produce a relatively accurate beam shape relative to the MLC orientation of $\phi=0^\circ$. Accordingly, selection of a constant MLC orientation ϕ may impact treatment plan quality and ultimately the radiation dose that is delivered to subject S. It is therefore important to consider which MLC orientation angle ϕ to select when using a constant MLC orientation angle ϕ to plan and deliver radiation to a subject S.

One aspect of the invention provides for radiation planning and delivery systems which provide a constant MLC orientation angle ϕ having a generally preferred value. Consider a trajectory **30** where radiation is delivered to a subject where there are substantially opposing radiation beams throughout the trajectory—i.e. beams that are parallel but have opposing directions. By way of non-limiting example, such a trajectory **30** may comprise rotation of gantry **16** through one full rotation of 180° or more. FIG. **17** shows the projections **305A**, **305B** of target **307** and healthy tissue **309** for opposing beam directions (e.g. a gantry angle of 0° (**305A**) and a gantry angle of 180° (**305B**). The projection of target **307** and healthy tissue **309** is approximately mirrored for the parallel and opposing beam directions.

It follows that a desirable beam shape from parallel and opposing beam directions will also be approximately mirrored. This observed symmetry may be exploited by selecting MLC orientation angles ϕ that result in a superior radiation plan. Consider the examples shown in FIGS. **16A** and **16B** with respect to the shaping capabilities of MLC **35**. For the two orientations shown in FIG. **16A** ($\phi=0^\circ$) and in FIG. **16B** ($\phi=90^\circ$), mirroring the desired beam shape will not change the ability of MLC **35** to create desired beam shape **301** because of the mirror symmetry already inherent in MLC **35**. In particular embodiments, MLC orientation angle ϕ is selected to exploit the mirroring of opposing beam projections by choosing an MLC orientation ϕ that is not 0° or 90° such that the MLC orientations ϕ with respect to the subject S will be different for opposing beam directions.

For example, choosing MLC orientation angle ϕ such that $|\phi|=45^\circ$ (where $|\cdot|$ represents an absolute value operator) will result in MLC orientations that are orthogonal to one another (i.e. with respect to the projection of subject S) when the beam is oriented in opposing beam directions. This is shown in FIGS. **18A** and **18B** which show MLC **35** and the projections of target **307** and healthy tissue **309** for opposing beam directions corresponding to opposing gantry angles of 0° (FIG. **18A**) and 180° (FIG. **18B**) and in FIGS. **18C** and **18D** which show MLC **35** and the projections of desired beam shape **301** for opposing beam directions corresponding to opposing gantry angles of 0° (FIG. **18C**) and 180° (FIG. **18D**). With this MLC orientation angle $|\phi|=45^\circ$, the beam shaping limitations associated with constant MLC orientation angle ϕ are thereby

reduced because effectively two different MLC orientation angles ϕ are available for opposing beam directions and may be used to provide a desired beam shape.

Other MLC orientation angles ϕ that are not $\phi=0^\circ$ or $\phi=90^\circ$ may also provide this advantage. Currently preferred embodiments incorporate MLC orientation angles ϕ such that $|\phi|$ is in a range 15° - 75° and particularly preferred embodiments incorporate MLC angles ϕ where $|\phi|$ is in a range of 30° - 60° . The benefit of selecting MLC orientation angles ϕ within these ranges may be realized for all substantially opposed beam orientations throughout the delivery of radiation and may be provided by any trajectories which comprise one or more substantially opposed beam directions. Non-limiting examples of such trajectories **30** include: trajectories **30** which comprise rotations of gantry **16** about axis **18** by any amount greater than 180° (e.g. 360° rotations of gantry **16** about axis **18**) and trajectories **30** which comprise multiple planar arcs wherein at least one of the arcs comprises opposing beam directions. Selection of MLC orientation angles ϕ within these ranges is not limited to trajectories **30** comprising opposing beams and may be used for any trajectories. These advantages of increased MLC shaping flexibility may be manifested as increased plan quality, reduced delivery time, reduced radiation beam output requirements or any combination of the above.

A further desirable aspect of providing MLC orientation angles ϕ that are not $\phi=0^\circ$ or $\phi=90^\circ$ relates to physical properties of typical MLCs **35**. Although individual MLC leaves **36** block most of radiation from radiation source **12**, there is often some undesirable radiation leakage that permeates MLC **35** and there is a relatively large amount of radiation leakage at the edges of MLC leaves **36** where they translate independently relative to each other. Choosing a MLC orientation angle $\phi=0^\circ$ with respect to the motion of beam **14** along source trajectory direction **43** may result in interleaf radiation leakage that is compounded in planes defined by the edges of MLC leaves **36** and the beam axis **37** for particular trajectories **30**. MLC orientation angles ϕ other than $\phi=0^\circ$ may cause the orientation of the interleaf leakage planes to change along the trajectory **30**, thereby reducing any systematic accumulation of unwanted radiation leakage and corresponding unwanted dose within subject S.

The edges of MLC leaves **36** may be constructed with a tongue-and-groove shape on each side for reduction of interleaf leakage. For some beam shapes, such tongue-and-groove MLC leaf edges may cause an unwanted reduction in radiation dose delivered to subject S. Similar to the effect on inter-leaf leakage, the tongue-and-groove underdosage effect will be compounded along the leaf edges. Selecting MLC orientation angles ϕ other than $\phi=0^\circ$ may reduce systematic underdosing of the subject S caused by these tongue-and-groove leaf edges.

Additional considerations that affect the selection of MLC orientation angle ϕ include the maximum speed of MLC leaves **36** as well as the ability of MLC **35** to create shapes that continuously block areas of important healthy tissue **309** while maintaining a relatively high dose to target **307**.

When it is desirable to block a central portion of radiation beam **14**, it can be more efficient to choose a MLC orientation angle ϕ other than $\phi=0^\circ$. In particular circumstances, blocking a central portion of radiation beam **14** may be achieved more efficiently when the MLC orientation angle ϕ is approximately $\phi=90^\circ$. In contrast, when there are dramatic changes in desired beam shape as source **12** moves along its trajectory **30**, it may be difficult for MLC leaves **36** to move into position with sufficient speed. Generally, the desired projection shape **301** will change more rapidly in the direction **43** of source

motion along trajectory **30**. It may therefore be desirable to have leaf-translation axis **41** oriented to approximately the same direction **43** as the source motion along trajectory **30**. Such a selection would result in a MLC orientation angle ϕ of approximately $\phi=0^\circ$.

The competing benefits/disadvantages of a MLC orientation angle ϕ of 0° versus 90° may be mitigated by using a MLC orientation angle ϕ that is substantially in between these two angles (i.e. approximately $|\phi|=45^\circ$). It will be appreciated that a MLC orientation angle ϕ of exactly $|\phi|=45^\circ$ is not essential and other factors specific to the given subject S to be irradiated may need to be considered when selecting a MLC orientation angle ϕ .

Certain implementations of the invention comprise computer processors which execute software instructions which cause the processors to perform a method of the invention. For example, one or more data processors may implement the methods of FIG. **4A** and/or FIG. **8** by executing software instructions in a program memory accessible to the data processors. The invention may also be provided in the form of a program product. The program product may comprise any medium which carries a set of computer-readable signals comprising instructions which, when executed by a data processor, cause the data processor to execute a method of the invention. Program products according to the invention may be in any of a wide variety of forms. The program product may comprise, for example: physical media such as magnetic data storage media including floppy diskettes, hard disk drives, optical data storage media including CD ROMs, DVDs, electronic data storage media including ROMs, flash RAM, or the like. The computer-readable signals on the program product may optionally be compressed or encrypted.

Where a component (e.g. a software module, processor, assembly, device, circuit, etc.) is referred to above, unless otherwise indicated, reference to that component (including a reference to a "means") should be interpreted as including as equivalents of that component any component which performs the function of the described component (i.e., that is functionally equivalent), including components which are not structurally equivalent to the disclosed structure which performs the function in the illustrated exemplary embodiments of the invention.

While a number of exemplary aspects and embodiments have been discussed above, those of skill in the art will recognize certain modifications, permutations, additions and sub-combinations thereof. For example:

In the embodiments described above, control points **32** used to define a trajectory **30** are the same as the control points used to perform the block **54** optimization process. This is not necessary. For example, a simple trajectory **30**, such as an arc of gantry **16** about axis **18** (FIG. **1**), may be defined by two control points at its ends. While such control points may define the trajectory, more control points will generally be required to achieve an acceptable treatment plan. Accordingly, the block **54**, **154** optimization processes may involve using different (e.g. more) control points than those used to define the trajectory.

In the embodiments described above, constraints (e.g. constraints on the changes in beam position/orientation parameters between control points **32**, constraints on the changes in beam shape parameters between control points **32** and constraints on the changes in the beam intensity between control points **32**) are used throughout the optimization processes **54**, **154**. In other embodiments, the optimization constraints may be imposed later in the optimization process. In this manner, more

31

flexibility is available in meeting the optimization goals **61** in an initial number of iterations. After the initial number of iterations is performed, the constraints may be introduced. The introduction of constraints may require that some beam position/orientation parameters, beam shape parameters and/or intensity parameters be changed, which may result in a need for further optimization to meet the optimization goals **61**.

In the embodiments described above, the beam position and beam orientation at each control point **32** are determined prior to commencing the optimization process **54**, **154** (e.g. in blocks **52**, **152**) and are maintained constant throughout the optimization process **54**, **154** (i.e. optimization processes **54**, **154** involve varying and optimizing beam shape parameters and beam intensity parameters, while trajectory **30** remains constant). In other embodiments, the beam position and beam orientation parameters (i.e. the set of motion axis positions at each control point **32**) are additionally or alternatively varied and optimized as a part of optimization processes **54**, **154**, such that optimization processes **54**, **154** optimize the trajectory **30** of the radiation delivery apparatus. In such embodiments, optimization processes **54**, **154** may involve placing constraints on the available motion axis positions and/or the rate of change of motion axis positions between control points **32** and such constraints may be related to the physical limitations of the particular radiation delivery apparatus being used to deliver the dose to the subject S.

In some embodiments, the radiation intensity may be held constant and the optimization processes **54**, **154** optimize the beam shape parameters and/or the motion axis parameters. Such embodiments are suitable for use in conjunction with radiation delivery apparatus which do not have the ability to controllably vary the radiation intensity. In some embodiments, the beam shape parameters may be held constant and the optimization processes **54**, **154** optimize the intensity and/or the motion axis parameters.

There are an infinite number of possible trajectories that can be used to describe the position and orientation of a radiation beam. Selection of such trajectories are limited only by the constraints of particular radiation delivery apparatus. It is possible to implement the invention using any trajectory capable of being provided by any suitable radiation delivery apparatus.

It is therefore intended that the following appended claims and claims hereafter introduced are interpreted to include all such modifications, permutations, additions and sub-combinations as are within their true spirit and scope.

What is claimed is:

1. A method for planning delivery of radiation dose to a target region within a subject, the method comprising:
iteratively optimizing, by a processor, a simulated dose distribution relative to a set of one or more optimization goals comprising a desired dose distribution in the subject over an initial plurality of control points along a trajectory which involves relative movement between a radiation source and the subject;
reaching one or more initial termination conditions, and after reaching the one or more initial termination conditions:
specifying, by the processor, an increased plurality of control points along the trajectory, the increased plurality of control points comprising a larger number of control points than the initial plurality of control

32

points, wherein the increased plurality of control points includes the initial plurality of control points; and

iteratively optimizing, by the processor, a simulated dose distribution relative to the set of one or more optimization goals over the increased plurality of control points to thereby determine a radiation delivery plan;

the radiation delivery plan configured to cause a radiation delivery apparatus to deliver radiation in accordance with the radiation delivery plan.

2. A method according to claim **1** wherein iteratively optimizing, by the processor, the simulated dose distribution relative to the set of one or more optimization goals over the initial plurality of control points comprises iteratively optimizing, by the processor, the simulated dose distribution subject to one or more initial optimization constraints.

3. A method according to claim **2** wherein iteratively optimizing, by the processor, the simulated dose distribution relative to the set of one or more optimization goals over the increased plurality of control points comprises iteratively optimizing, by the processor, the simulated dose distribution subject to one or more subsequent optimization constraints.

4. A method according to claim **3** wherein at least one of the subsequent optimization constraints is different than a corresponding at least one of the initial optimization constraints.

5. A method according to claim **1** comprising discontinuing the iterative optimization over the increased plurality of control points after reaching one or more subsequent termination conditions.

6. A method according to claim **5** wherein:

prior to reaching the one or more initial termination conditions, a difference between the simulated dose distribution and the set of one or more optimization goals is greater than an acceptable dose quality threshold; and

before discontinuing the iterative optimization over the increased plurality of control points, the difference between the simulated dose distribution and the set of one or more optimization goals is within the acceptable dose quality threshold.

7. A method according to claim **1** wherein iteratively optimizing, by the processor, the simulated dose distribution relative to the set of one or more optimization goals over the initial plurality of control points comprises achieving an initial dose simulation accuracy and wherein iteratively optimizing, by the processor, the simulated dose distribution relative to the set of one or more optimization goals over the increased plurality of control points comprises achieving an increased dose simulation accuracy, the increased dose simulation accuracy more accurately representing actual dose distribution in the subject than the initial dose simulation accuracy.

8. A method according to claim **1** wherein iteratively optimizing, by the processor, the simulated dose distribution relative to the set of one or more optimization goals over the initial plurality of control points comprises modeling, by the processor, a dose contribution for at least one of the initial plurality of control points by:

dividing a cross-sectional area of a beam into a plurality of two-dimensional beamlets; and

simulating a dose distribution contribution from each of the plurality of two-dimensional beamlets.

9. A method according to claim **1** wherein the trajectory comprises a plurality of arcs, each arc involving relating movement between the radiation source and the subject within a corresponding plane.

10. A method according to claim 1 comprising at least one of: defining the set of one or more optimization goals; and receiving the set of one or more optimization goals from an external source.

11. A method according to claim 1 comprising providing the radiation delivery plan to the radiation delivery apparatus.

12. A method according to claim 11 comprising delivering, by the radiation delivery apparatus, radiation in accordance with the radiation delivery plan.

13. A method for planning delivery of radiation dose to a target region

within a subject, the method comprising:

iteratively optimizing, by a processor, a simulated dose distribution relative to a set of one or more optimization goals comprising a desired dose distribution in the subject over an initial plurality of control points along a trajectory which involves relative movement between a radiation source and the subject;

reaching one or more initial termination conditions, and after reaching the one or more initial termination conditions:

specifying, by the processor, an increased plurality of control points along the trajectory, the increased plurality of control points comprising a larger number of control points than the initial plurality of control points; and

iteratively optimizing, by the processor, a simulated dose distribution relative to the set of one or more optimization goals over the increased plurality of control points to thereby determine a radiation delivery plan;

the radiation delivery plan capable of causing a radiation delivery apparatus to deliver radiation in accordance with the radiation delivery plan;

wherein iteratively optimizing, by the processor, the simulated dose distribution relative to the set of one or more optimization goals over the increased plurality of control points comprises, for each iteration:

varying, by the processor, one or more radiation delivery parameters associated with one or more of the increased plurality of control points;

determining, by the processor, the simulated dose distribution based on the one or more varied radiation delivery parameters;

determining, by the processor and on the basis of an optimization algorithm and the simulated dose distribution based on the one or more varied radiation delivery parameters, whether to accept or reject the one or more varied radiation delivery parameters; and

after a determination is made to accept the one or more varied radiation delivery parameters, updating, by the processor, current radiation delivery parameters to include the one or more varied radiation delivery parameters.

14. A method according to claim 13 wherein the one or more radiation delivery parameters comprise one or more configurations of a multi-leaf collimator.

15. A method according to claim 14 wherein the one or more configurations of the multi-leaf collimator comprise positions of one or more leaves of the multi-leaf collimator.

16. A method according to claim 15 wherein the trajectory involves relative movement between the radiation source and the subject in a source trajectory direction, wherein the one or more leaves of the multi-leaf collimator are moveable in a leaf-translation direction and wherein, during relative movement between the radiation source and the subject along the trajectory, the leaf-translation direction is oriented at a MLC

orientation angle ϕ with respect to the source trajectory direction, an absolute value of the MLC orientation angle ϕ satisfying $0^\circ < |\phi| < 90^\circ$.

17. A method according to claim 16 wherein the absolute value of the MLC orientation angle ϕ satisfies $30^\circ \leq |\phi| \leq 60^\circ$.

18. A method according to claim 8 wherein iteratively optimizing, by the processor, the simulated dose distribution relative to the set of one or more optimization goals over the initial plurality of control points comprises mapping, by the processor, between the plurality of two dimensional beamlets and one or more of: a position of the radiation source and orientation of a beam from the radiation source relative to the subject; a beam shape involving a configuration of one or more leaves of a multi-leaf collimator; and an intensity of the radiation source.

19. A method according to claim 15 wherein the trajectory involves relative movement between the radiation source and the subject in a source trajectory direction, wherein the one or more leaves of the multi-leaf collimator are moveable in a leaf-translation direction and wherein, during relative movement between the radiation source and the subject along the trajectory, the leaf-translation direction is oriented at a MLC orientation angle ϕ with respect to the source trajectory direction, the MLC orientation angle constant throughout the trajectory.

20. A method according to claim 13 wherein the one or more radiation delivery parameters comprise an intensity of the radiation source for a plurality of the increased plurality of control points.

21. A method according to claim 13 comprising providing the radiation delivery plan to the radiation delivery apparatus.

22. A method according to claim 21 comprising delivering, by the radiation delivery apparatus, radiation in accordance with the radiation delivery plan.

23. A method for planning delivery of radiation dose to a target region

within a subject, the method comprising:

iteratively optimizing, by a processor, a simulated dose distribution relative to a set of one or more optimization goals comprising a desired dose distribution in the subject over an initial plurality of control points along a trajectory which involves relative movement between a radiation source and the subject;

reaching one or more initial termination conditions, and after reaching the one or more initial termination conditions:

specifying, by the processor, an increased plurality of control points along the trajectory, the increased plurality of control points comprising a larger number of control points than the initial plurality of control points; and

iteratively optimizing, by the processor, a simulated dose distribution relative to the set of one or more optimization goals over the increased plurality of control points to thereby determine a radiation delivery plan;

the radiation delivery plan capable of causing a radiation delivery apparatus to deliver radiation in accordance with the radiation delivery plan;

wherein iteratively optimizing, by the processor, the simulated dose distribution relative to the set of one or more optimization goals over the initial plurality of control points comprises performing, by the processor, the iterative optimization using a set of optimization parameters, the set of optimization parameters representative of one or more of: a beam shape of the radiation source; and a beam intensity of the radiation source.

24. A method according to claim 23 wherein specifying, by the processor, an increased plurality of control points com-

35

prises assigning, by the processor, optimization parameters to the increased plurality of control points not present among the initial plurality of control points, wherein assigning, by the processor, optimization parameters comprises interpolating, by the processor, optimization parameters based on the optimization parameters associated with the initial plurality of control points.

25. A method according to claim 23 comprising providing the radiation delivery plan to the radiation delivery apparatus.

26. A method according to claim 25 comprising delivering, by the radiation delivery apparatus, radiation in accordance with the radiation delivery plan.

27. A method for planning delivery of radiation dose to a target region

within a subject, the method comprising:

iteratively optimizing, by a processor, a simulated dose distribution relative to a set of one or more optimization goals comprising a desired dose distribution in the subject over an initial plurality of control points along a trajectory which involves relative movement between a radiation source and the subject;

reaching one or more initial termination conditions, and after reaching the one or more initial termination conditions:

specifying, by the processor, an increased plurality of control points along the trajectory, the increased plurality of control points comprising a larger number of control points than the initial plurality of control points; and

iteratively optimizing, by the processor, a simulated dose distribution relative to the set of one or more optimization goals over the increased plurality of control points to thereby determine a radiation delivery plan;

the radiation delivery plan capable of causing a radiation delivery apparatus to deliver radiation in accordance with the radiation delivery plan;

wherein the trajectory comprises at least one pair of locations where a first beam directed from the radiation source toward the subject from a first one of the pair of locations and a second beam directed from the radiation source toward the subject from a second one of the pair of locations are substantially parallel but opposing one another.

28. A method according to claim 27 comprising providing the radiation delivery plan to the radiation delivery apparatus.

29. A method according to claim 28 comprising delivering, by the radiation delivery apparatus, radiation in accordance with the radiation delivery plan.

30. A method for planning delivery of radiation dose to a target region

within a subject, the method comprising:

iteratively optimizing, by a processor, a simulated dose distribution relative to a set of one or more optimization goals comprising a desired dose distribution in the subject over an initial plurality of control points along a trajectory which involves relative movement between a radiation source and the subject;

reaching one or more initial termination conditions, and after reaching the one or more initial termination conditions:

specifying, by the processor, an increased plurality of control points along the trajectory, the increased plurality of control points comprising a larger number of control points than the initial plurality of control points; and

iteratively optimizing, by the processor, a simulated dose distribution relative to the set of one or more optimiza-

36

tion goals over the increased plurality of control points to thereby determine a radiation delivery plan;

the radiation delivery plan capable of causing a radiation delivery apparatus to deliver radiation in accordance with the radiation delivery plan;

wherein the trajectory comprises a plurality of arcs, each arc involving relating movement between the radiation source and the subject within a corresponding plane;

wherein between successive ones of the plurality of arcs, the trajectory comprises inter-arc relative movement between the radiation source and the subject, the inter-arc relative movement comprising movement such that the corresponding planes associated with each arc intersect one another.

31. A method according to claim 30 comprising providing the radiation delivery plan to the radiation delivery apparatus.

32. A method according to claim 31 comprising delivering, by the radiation delivery apparatus, radiation in accordance with the radiation delivery plan.

33. A method for planning delivery of radiation dose to a target region

within a subject, the method comprising:

iteratively optimizing, by a processor, a simulated dose distribution relative to a set of one or more optimization goals comprising a desired dose distribution in the subject over an initial plurality of control points along a trajectory which involves relative movement between a radiation source and the subject;

reaching one or more initial termination conditions, and after reaching the one or more initial termination conditions:

specifying, by the processor, an increased plurality of control points along the trajectory, the increased plurality of control points comprising a larger number of control points than the initial plurality of control points; and

iteratively optimizing, by the processor, a simulated dose distribution relative to the set of one or more optimization goals over the increased plurality of control points to thereby determine a radiation delivery plan;

the radiation delivery plan capable of causing a radiation delivery apparatus to deliver radiation in accordance with the radiation delivery plan;

wherein the trajectory comprises a plurality of arcs, each arc involving relating movement between the radiation source and the subject within a corresponding plane;

wherein between successive ones of the plurality of arcs, the trajectory comprises inter-arc relative movement between the radiation source and the subject, the inter-arc relative movement comprising movement such that the corresponding planes associated with each arc are parallel to one another.

34. A method according to claim 33 comprising providing the radiation delivery plan to the radiation delivery apparatus.

35. A method according to claim 34 comprising delivering, by the radiation delivery apparatus, radiation in accordance with the radiation delivery plan.

36. A method for planning delivery of radiation dose to a target region

within a subject, the method comprising:

iteratively optimizing, by a processor, a simulated dose distribution relative to a set of one or more optimization goals comprising a desired dose distribution in the subject over an initial plurality of control points along a trajectory which involves relative movement between a radiation source and the subject;

37

reaching one or more initial termination conditions, and after reaching the one or more initial termination conditions:

specifying, by the processor, an increased plurality of control points along the trajectory, the increased plurality of control points comprising a larger number of control points than the initial plurality of control points; and

iteratively optimizing, by the processor, a simulated dose distribution relative to the set of one or more optimization goals over the increased plurality of control points to thereby determine a radiation delivery plan;

the radiation delivery plan capable of causing a radiation delivery apparatus to deliver radiation in accordance with the radiation delivery plan;

wherein the trajectory comprises a non-self overlapping trajectory which involves non-self overlapping relative movement between the radiation source and the subject.

37. A method according to claim **36** comprising providing the radiation delivery plan to the radiation delivery apparatus.

38. A method according to claim **37** comprising delivering, by the radiation delivery apparatus, radiation in accordance with the radiation delivery plan.

39. A method for planning delivery of radiation dose to a target region within a subject, the method comprising:

iteratively optimizing, by a processor, a simulated dose distribution relative to a set of one or more optimization goals comprising a desired dose distribution in the subject over an initial plurality of control points along a trajectory which involves relative movement between a radiation source and the subject;

reaching one or more initial termination conditions, and after reaching the one or more initial termination conditions:

specifying, by the processor, an increased plurality of control points along the trajectory, the increased plurality of control points comprising a larger number of control points than the initial plurality of control points; and

iteratively optimizing, by the processor, a simulated dose distribution relative to the set of one or more optimization goals over the increased plurality of control points to thereby determine a radiation delivery plan;

the radiation delivery plan capable of causing a radiation delivery apparatus to deliver radiation in accordance with the radiation delivery plan;

wherein a start of the trajectory and an end of the trajectory comprise the same relative position between the radiation source and the subject and the trajectory is otherwise non-self overlapping.

40. A method according to claim **39** comprising providing the radiation delivery plan to the radiation delivery apparatus.

41. A method according to claim **40** comprising delivering, by the radiation delivery apparatus, radiation in accordance with the radiation delivery plan.

42. A program product comprising a non-transitory computer-readable medium comprising computer readable

38

instructions which, when executed by a processor, cause the processor to execute a method for planning delivery of radiation dose to a target region within a subject, the method comprising:

iteratively optimizing a simulated dose distribution relative to a set of one or more optimization goals comprising a desired dose distribution in the subject over an initial plurality of control points along a trajectory which involves relative movement between a radiation source and the subject;

reaching one or more initial termination conditions, and after reaching the one or more initial termination conditions:

specifying an increased plurality of control points along the trajectory, the increased plurality of control points comprising a larger number of control points than the initial plurality of control points, wherein the increased plurality of control points includes the initial plurality of control points; and

iteratively optimizing a simulated dose distribution relative to the set of one or more optimization goals over the increased plurality of control points.

43. A program product comprising a non-transitory computer-readable medium comprising computer readable instructions which, when executed by a processor, cause the processor to execute the method of claim **1**.

44. A program product comprising a non-transitory computer-readable medium comprising computer readable instructions which, when executed by a processor, cause the processor to execute the method of claim **13**.

45. A program product comprising a non-transitory computer-readable medium comprising computer readable instructions which, when executed by a processor, cause the processor to execute the method of claim **23**.

46. A program product comprising a non-transitory computer-readable medium comprising computer readable instructions which, when executed by a processor, cause the processor to execute the method of claim **27**.

47. A program product comprising a non-transitory computer-readable medium comprising computer readable instructions which, when executed by a processor, cause the processor to execute the method of claim **30**.

48. A program product comprising a non-transitory computer-readable medium comprising computer readable instructions which, when executed by a processor, cause the processor to execute the method of claim **33**.

49. A program product comprising a non-transitory computer-readable medium comprising computer readable instructions which, when executed by a processor, cause the processor to execute the method of claim **36**.

50. A program product comprising a non-transitory computer-readable medium comprising computer readable instructions which, when executed by a processor, cause the processor to execute the method of claim **39**.

* * * * *