



US008678689B2

(12) **United States Patent**
Kawaguchi

(10) **Patent No.:** **US 8,678,689 B2**
(45) **Date of Patent:** **Mar. 25, 2014**

(54) **PRINTER WITH A CUTTER**

(56) **References Cited**

(75) Inventor: **Kouji Kawaguchi**, Chiba (JP)

U.S. PATENT DOCUMENTS

(73) Assignee: **Seiko Instruments Inc.** (JP)

6,155,731 A 12/2000 Bertalan et al. 400/621
6,361,231 B1 3/2002 Sato et al. 400/621

(*) Notice: Subject to any disclaimer, the term of this patent is extended or adjusted under 35 U.S.C. 154(b) by 450 days.

FOREIGN PATENT DOCUMENTS

(21) Appl. No.: **12/930,323**

EP 0775585 5/1997
EP 0832753 4/1998
EP 1506875 2/2005
JP 2000272200 10/2000

(22) Filed: **Jan. 4, 2011**

Primary Examiner — Leslie J Evanisko

(65) **Prior Publication Data**

US 2011/0170930 A1 Jul. 14, 2011

(74) *Attorney, Agent, or Firm* — Adams & Wilks

(30) **Foreign Application Priority Data**

Jan. 8, 2010 (JP) 2010-003355

(57) **ABSTRACT**

(51) **Int. Cl.**
B41J 11/66 (2006.01)
B41J 11/70 (2006.01)

A printer has a main unit supporting one of a platen roller and a recording head and has a movable blade, a movable blade holder holding the movable blade, a reciprocating mechanism for reciprocating the movable blade holder to slide the movable blade, a drive gear that drives the reciprocating mechanism, a motor that rotationally drives the drive gear, and a gear train mechanism that transmits a rotational force of the drive gear to the reciprocating mechanism. A detachable unit supports the other of the platen roller and the recording head and has a fixed blade for cutting the recording sheet in association with the movable blade. The detachable unit is attachable to and detachable from the main unit and moves close to and away from the main unit along a sliding direction of the movable blade when the detachable unit is attached to and detached from the main unit.

(52) **U.S. Cl.**
USPC **400/621**

(58) **Field of Classification Search**
USPC 400/621
IPC B41J 11/66,11/70
See application file for complete search history.

20 Claims, 22 Drawing Sheets

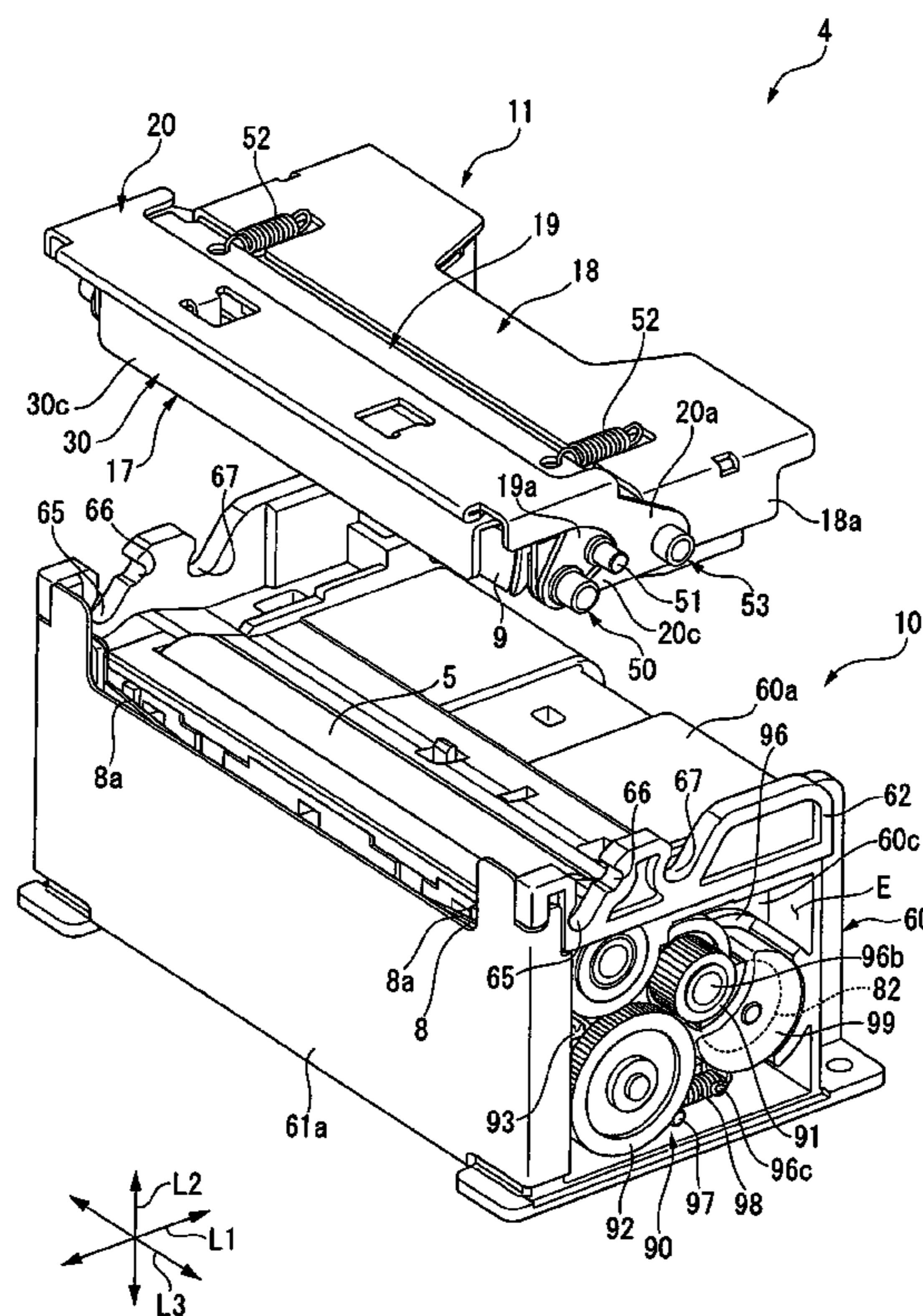

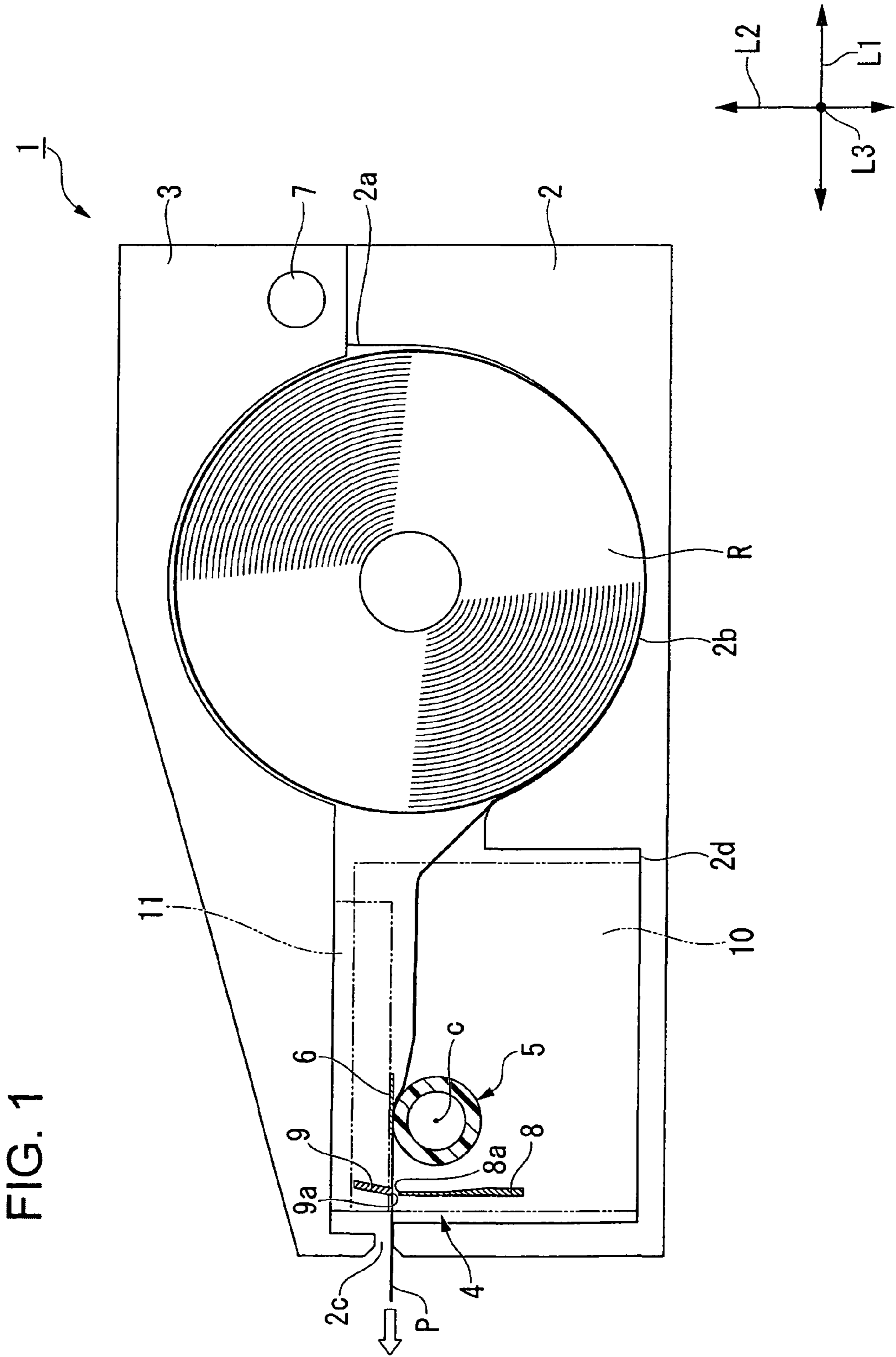

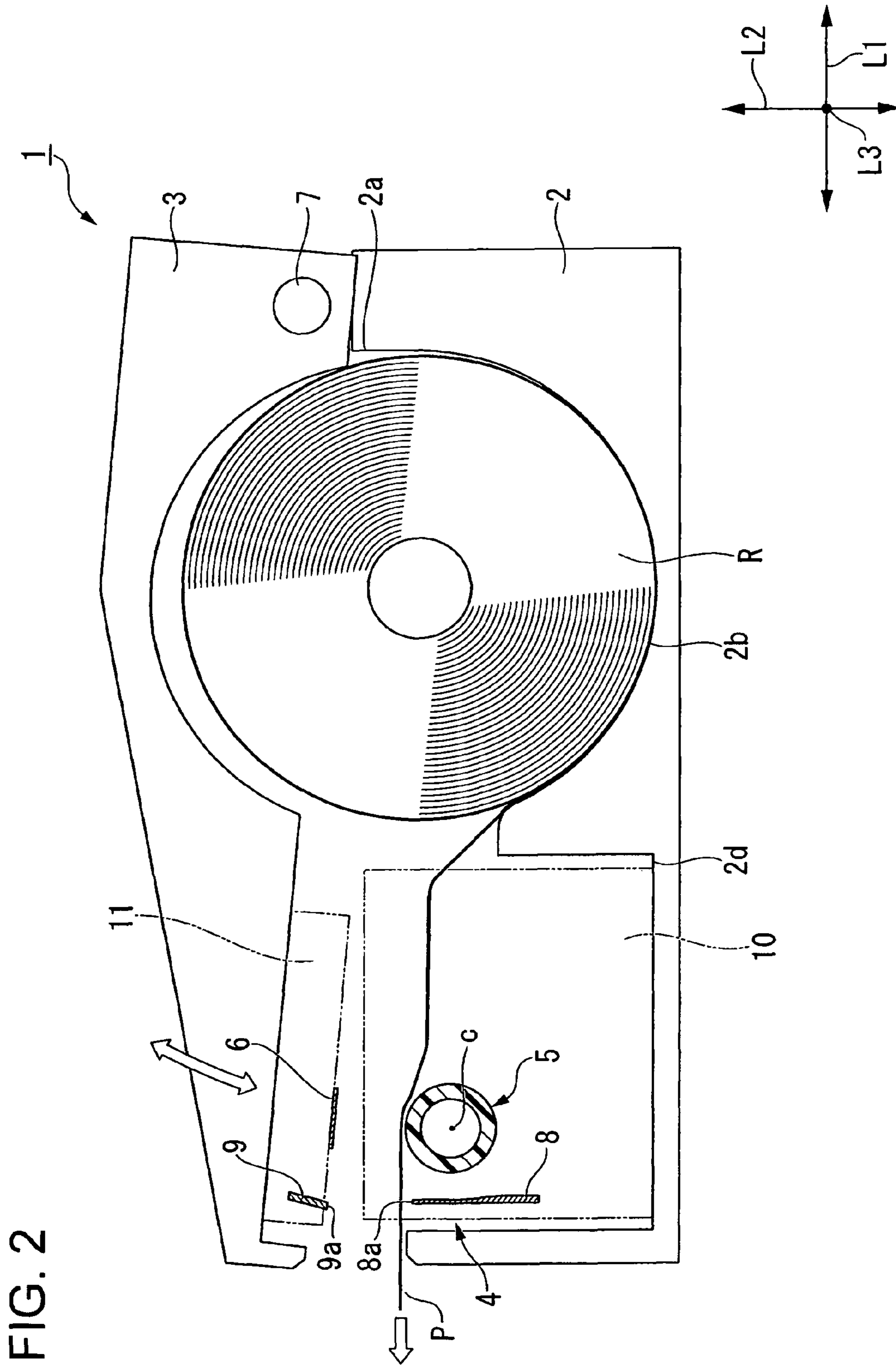

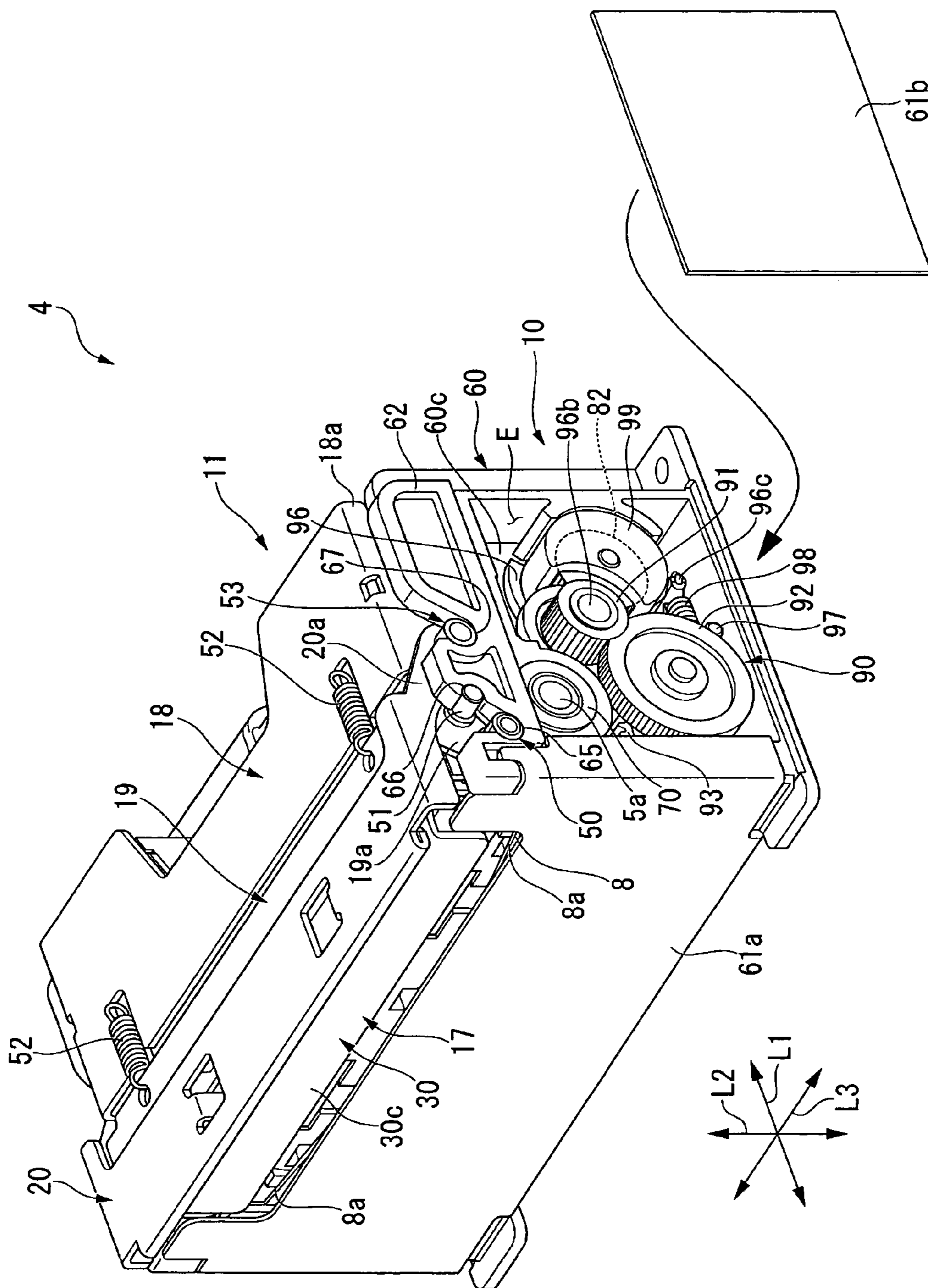

FIG. 3

FIG. 4

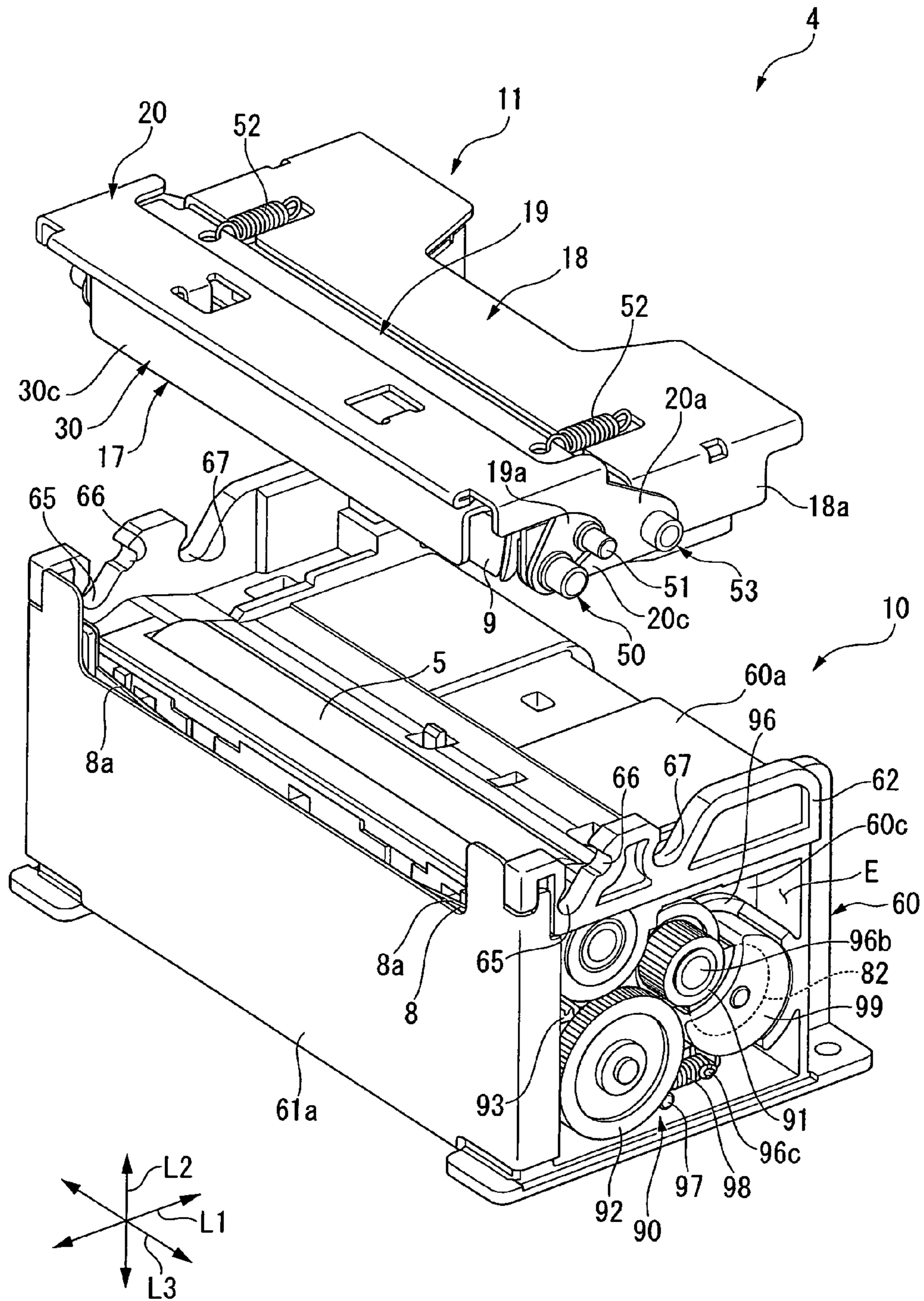
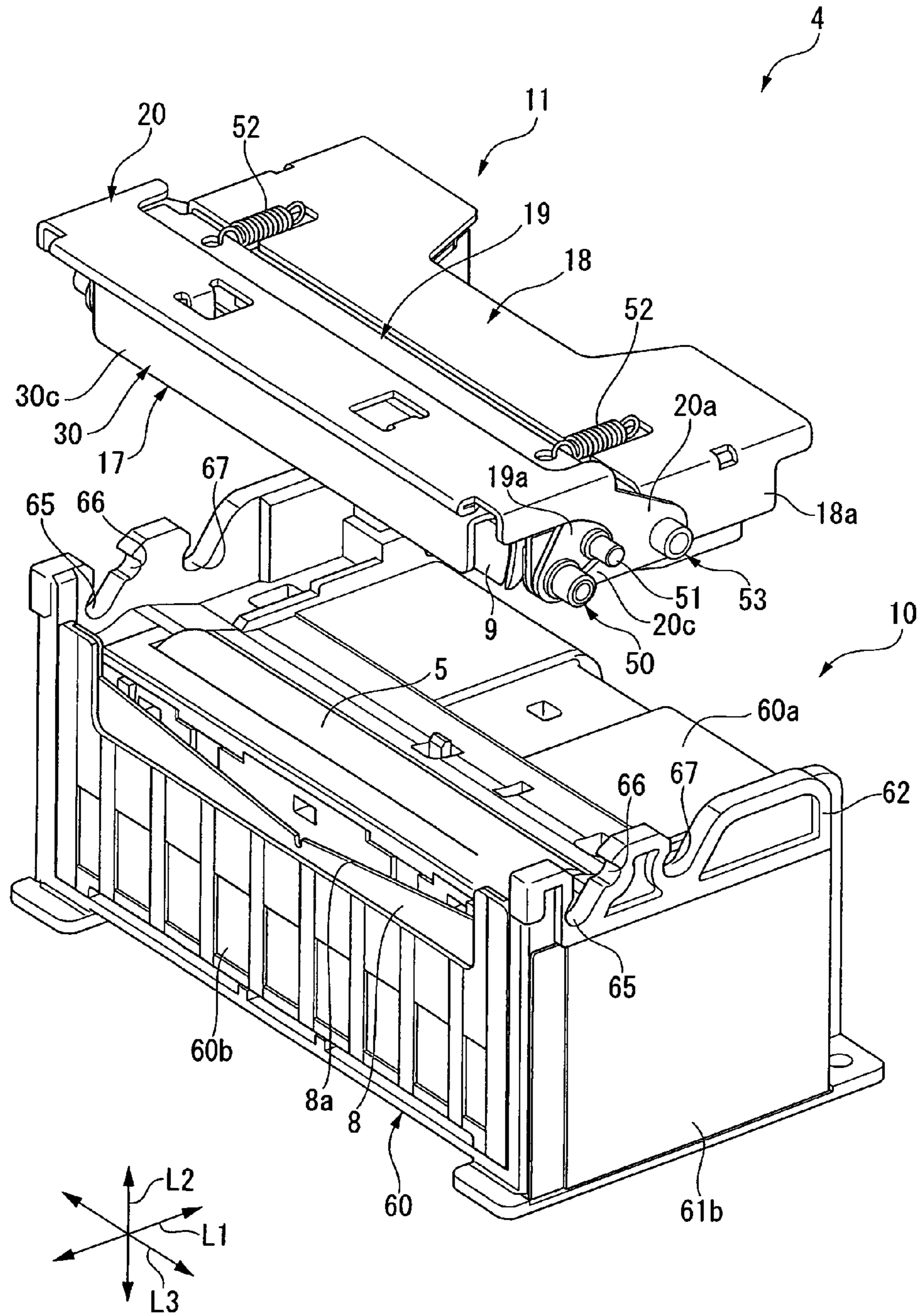

FIG. 5



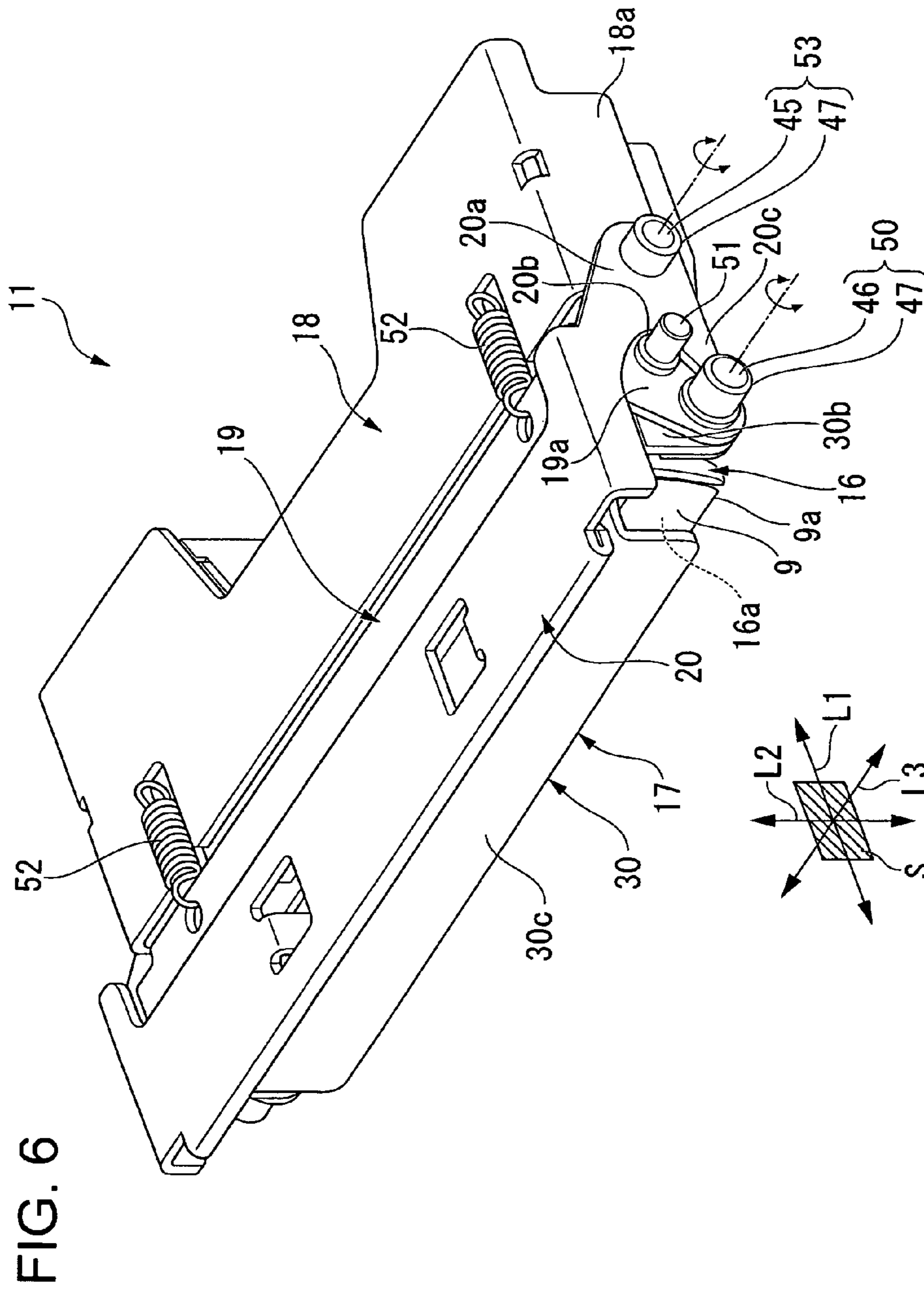

FIG. 7

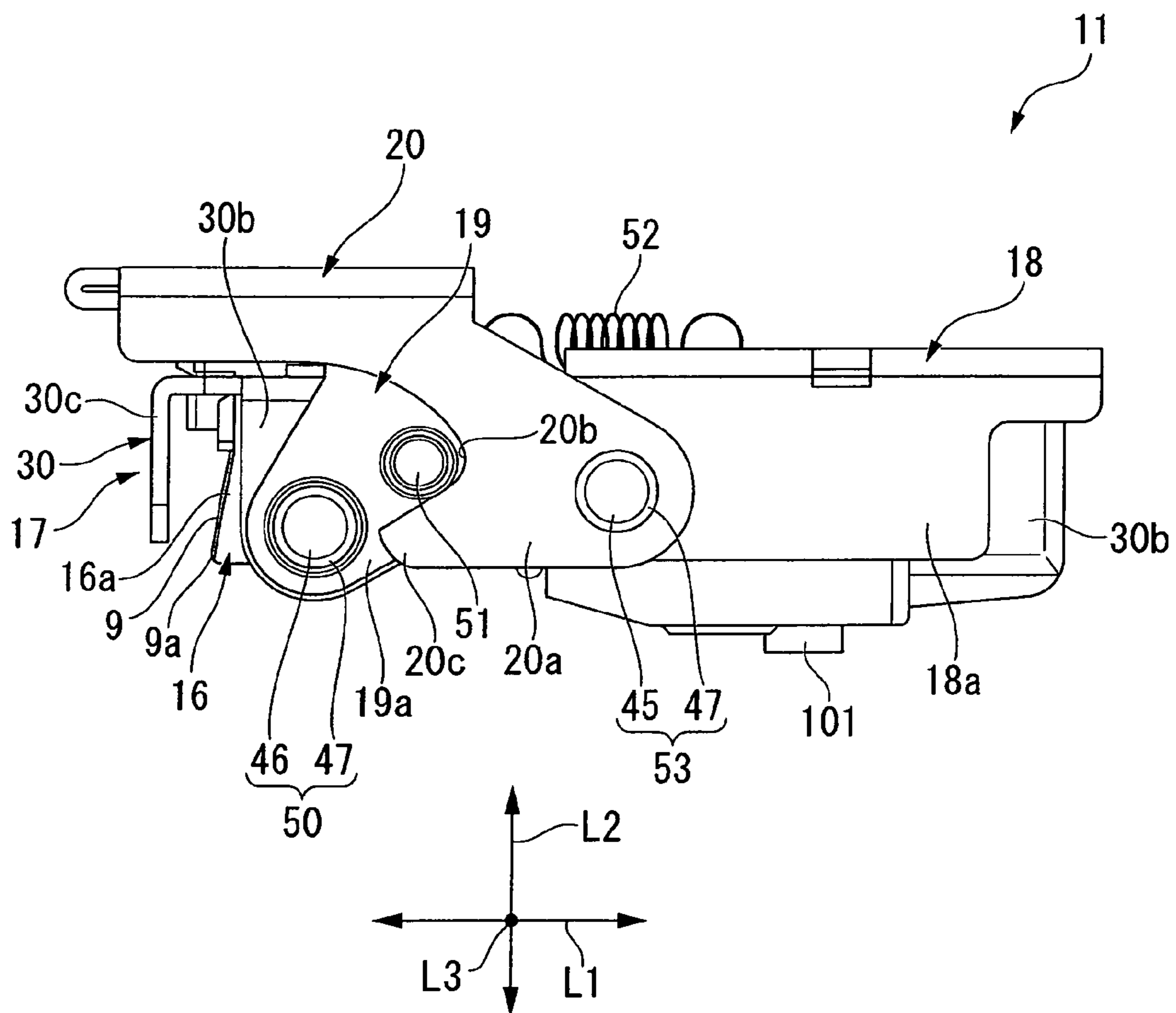

FIG. 8

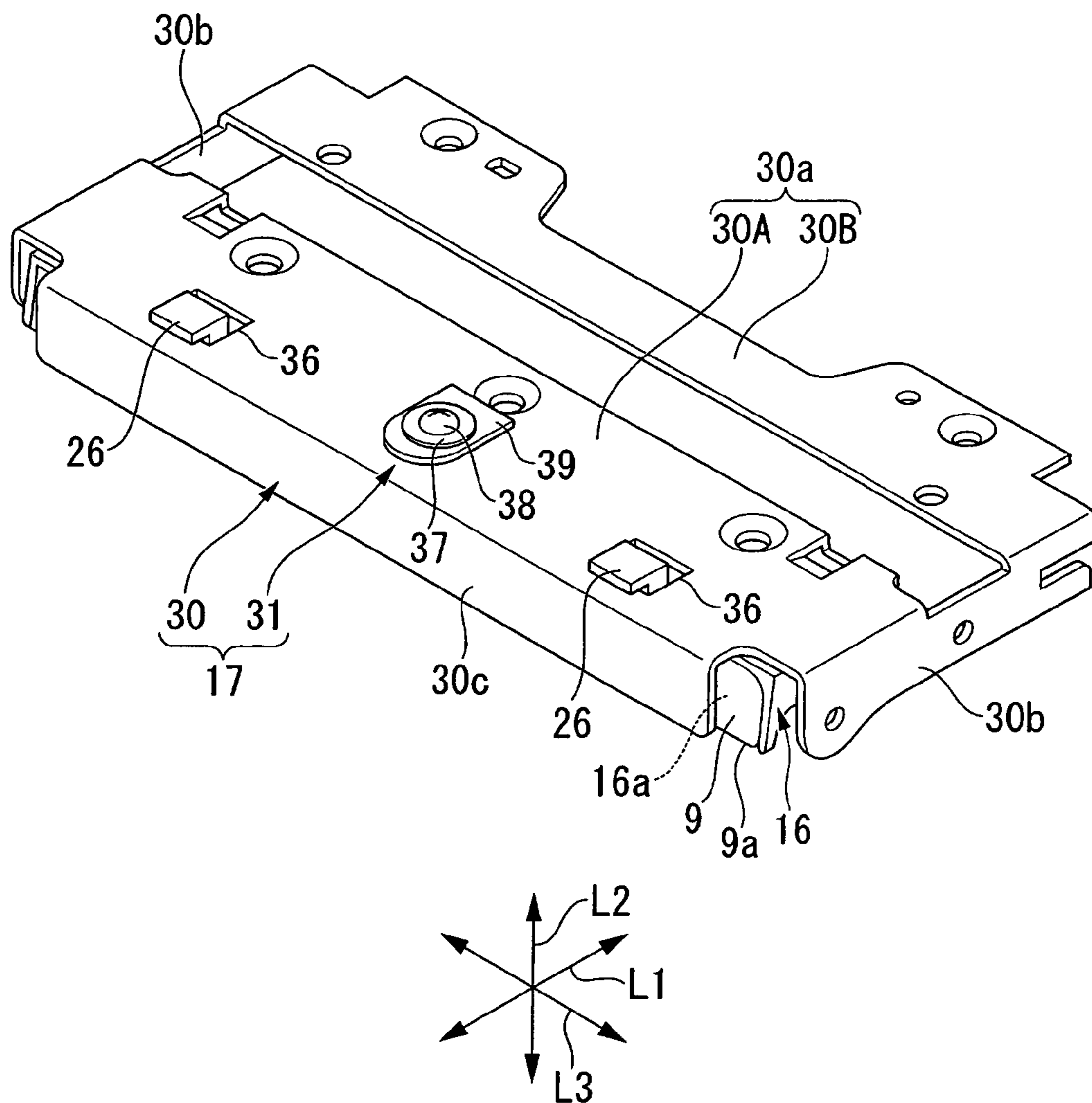

FIG. 9

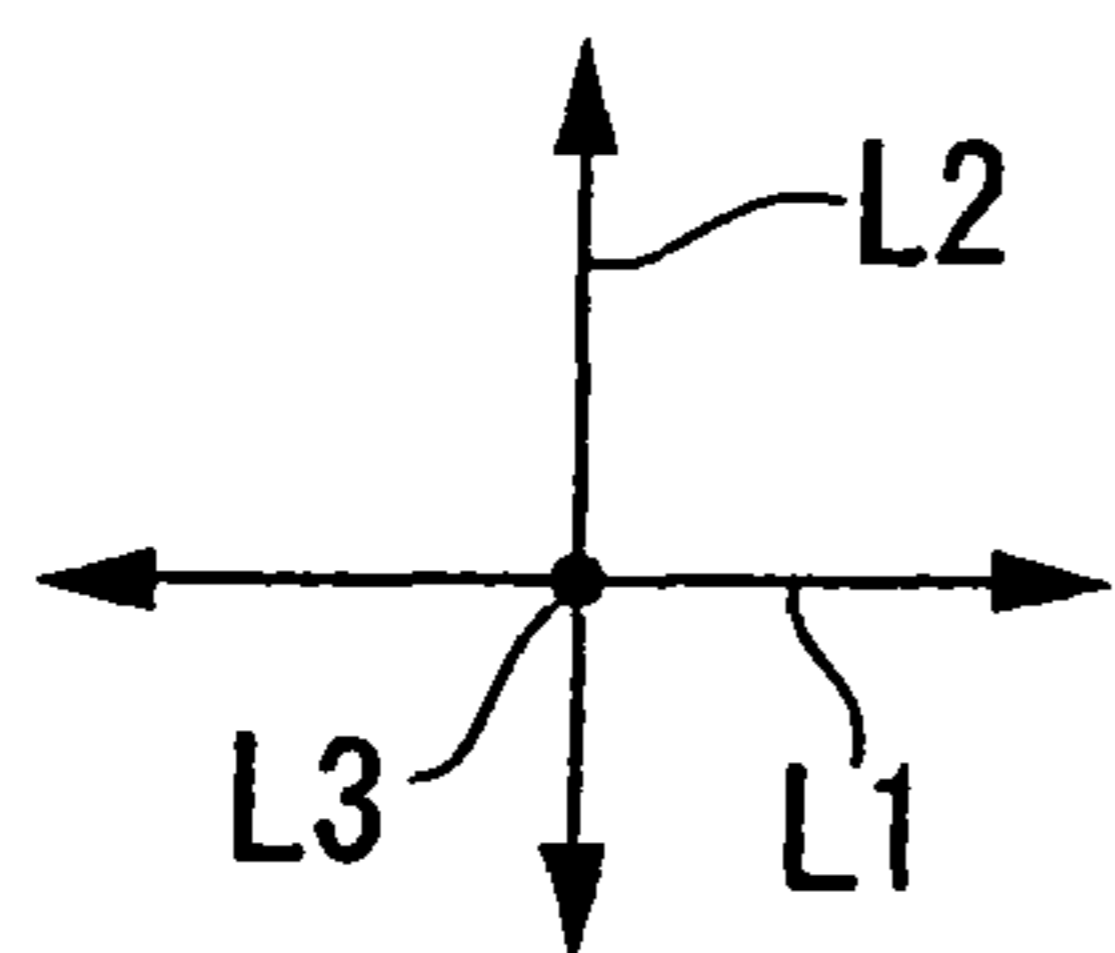
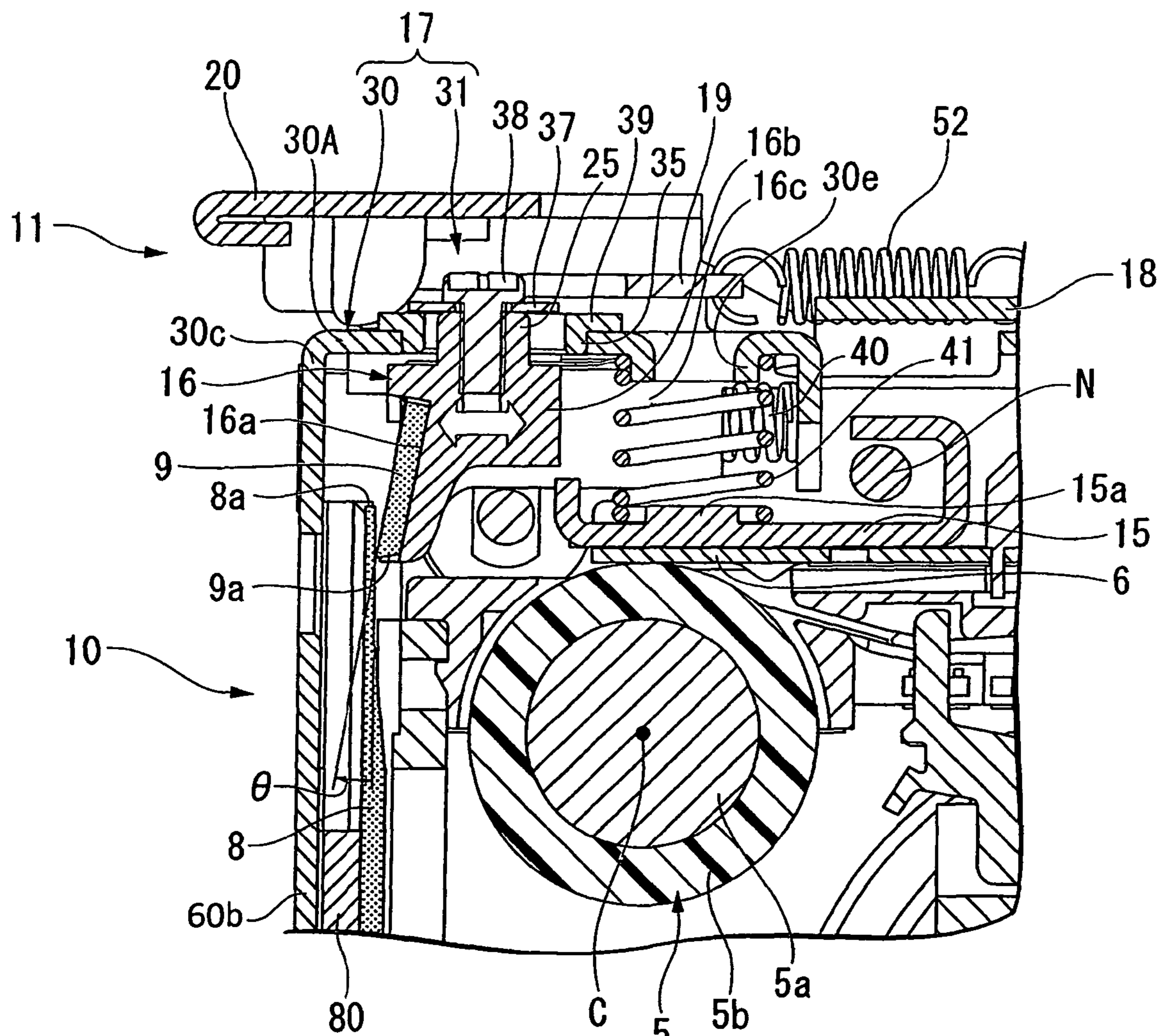

FIG. 10

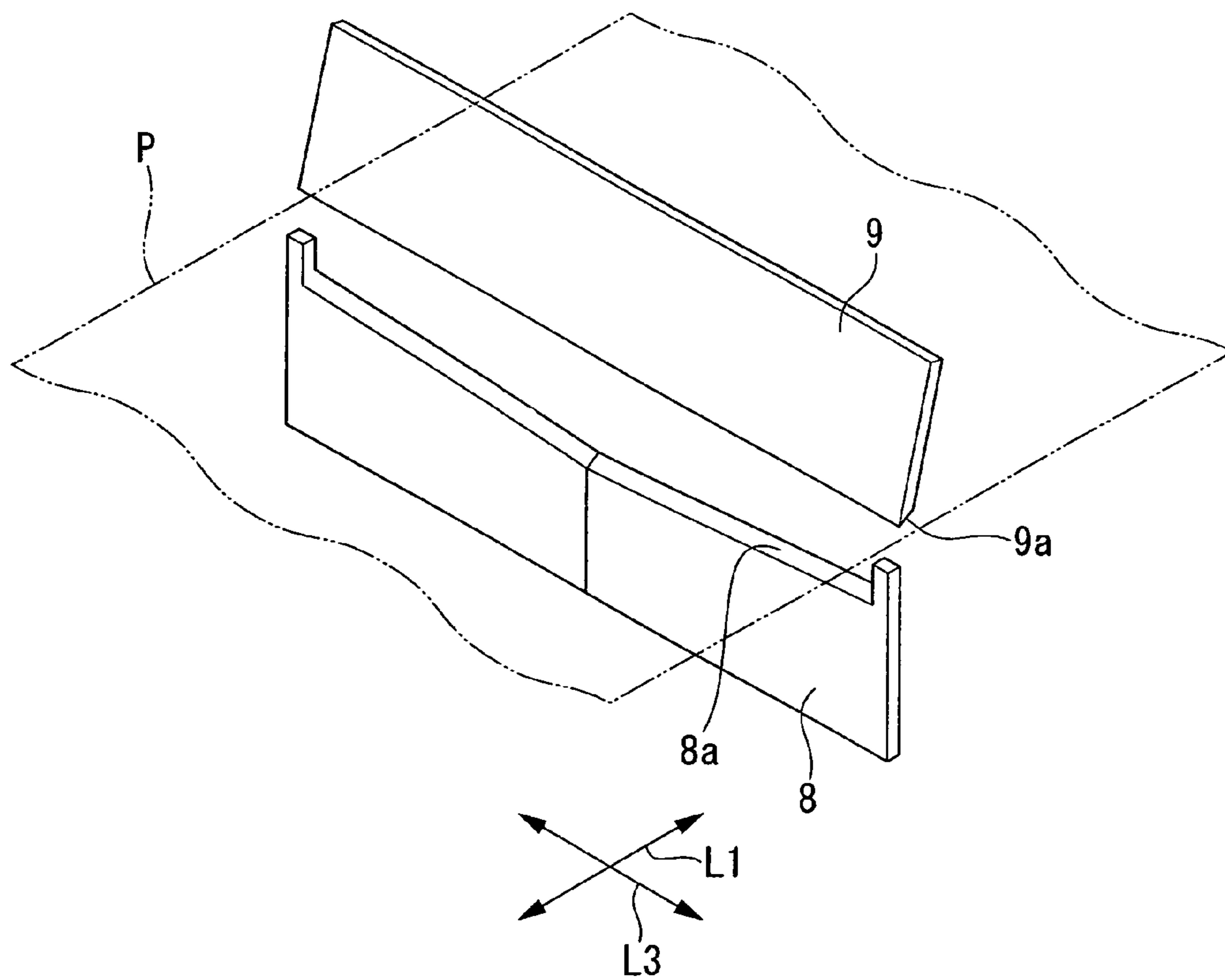

FIG. 11

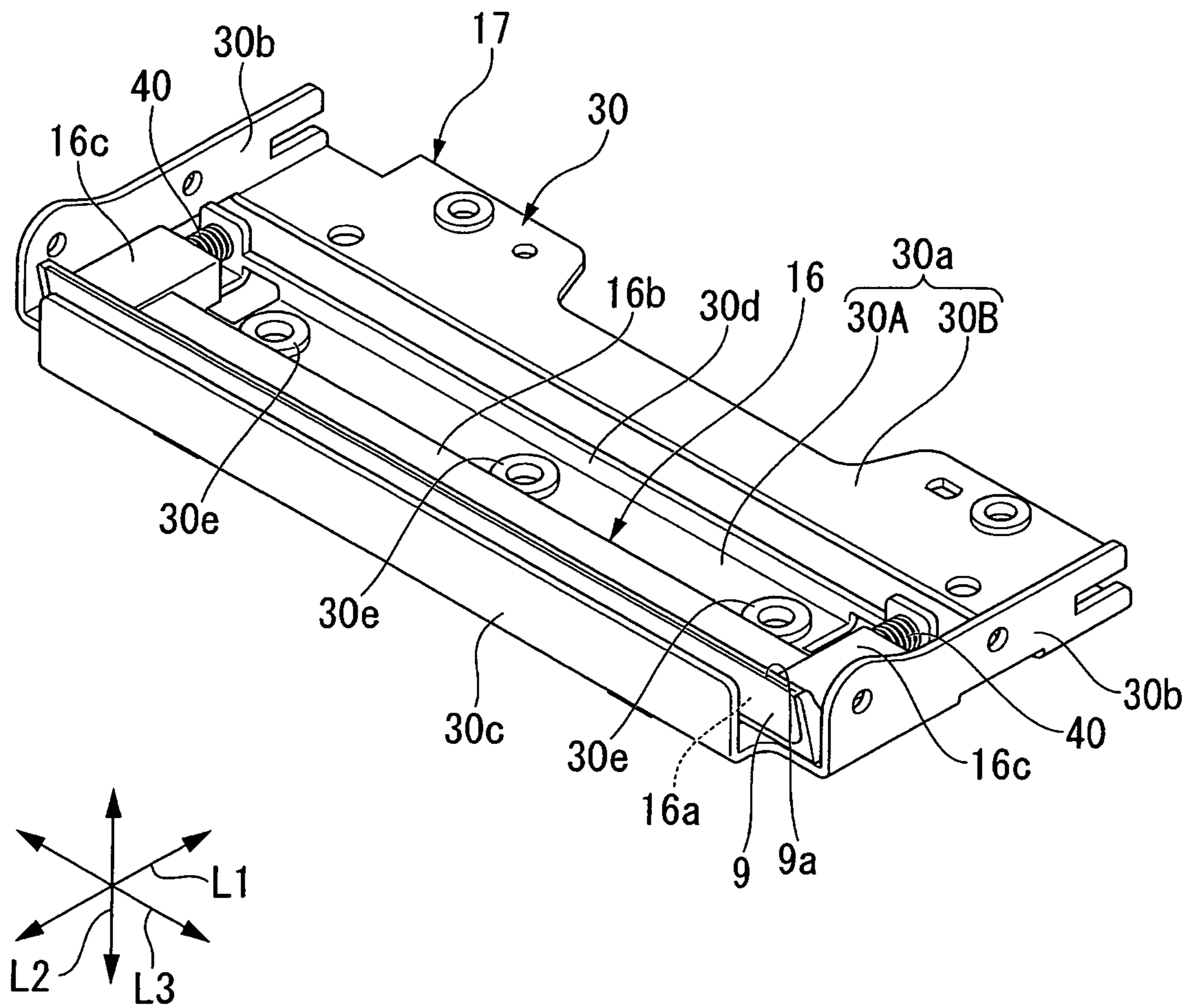

FIG. 12

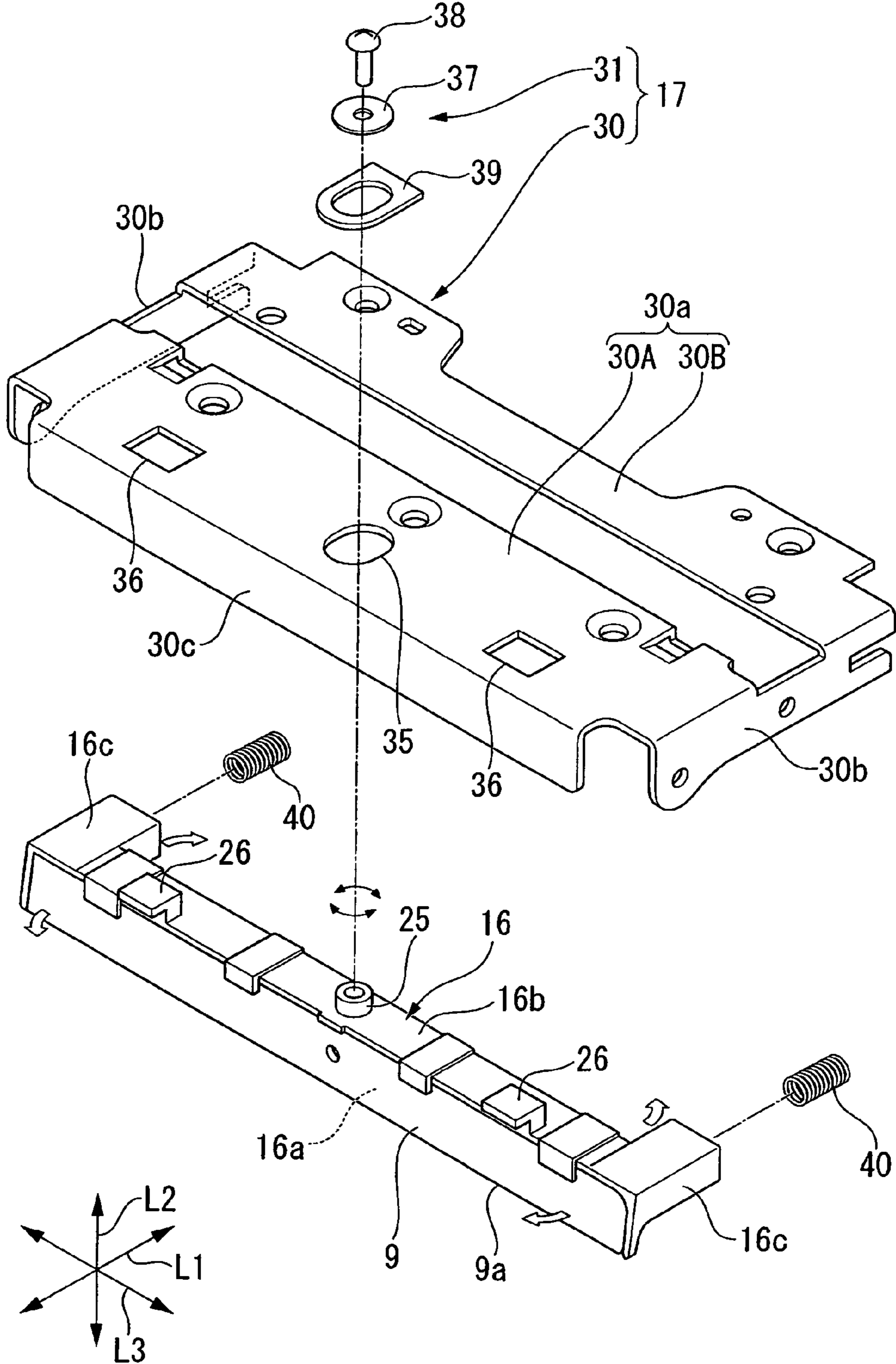

FIG. 13

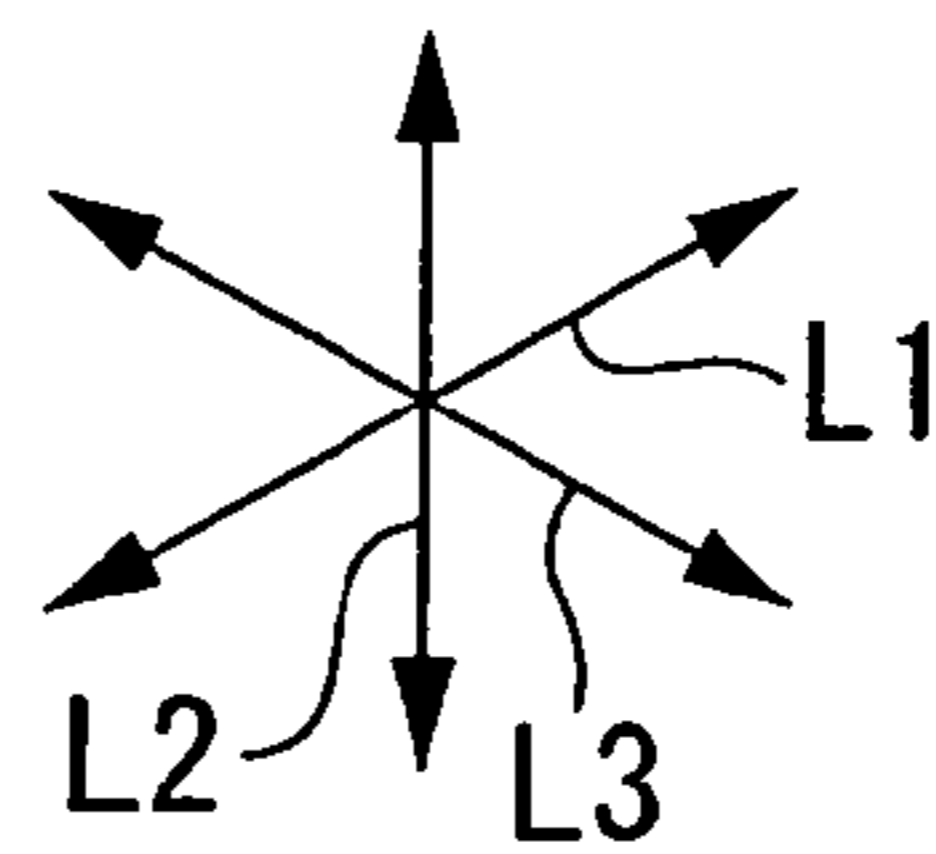
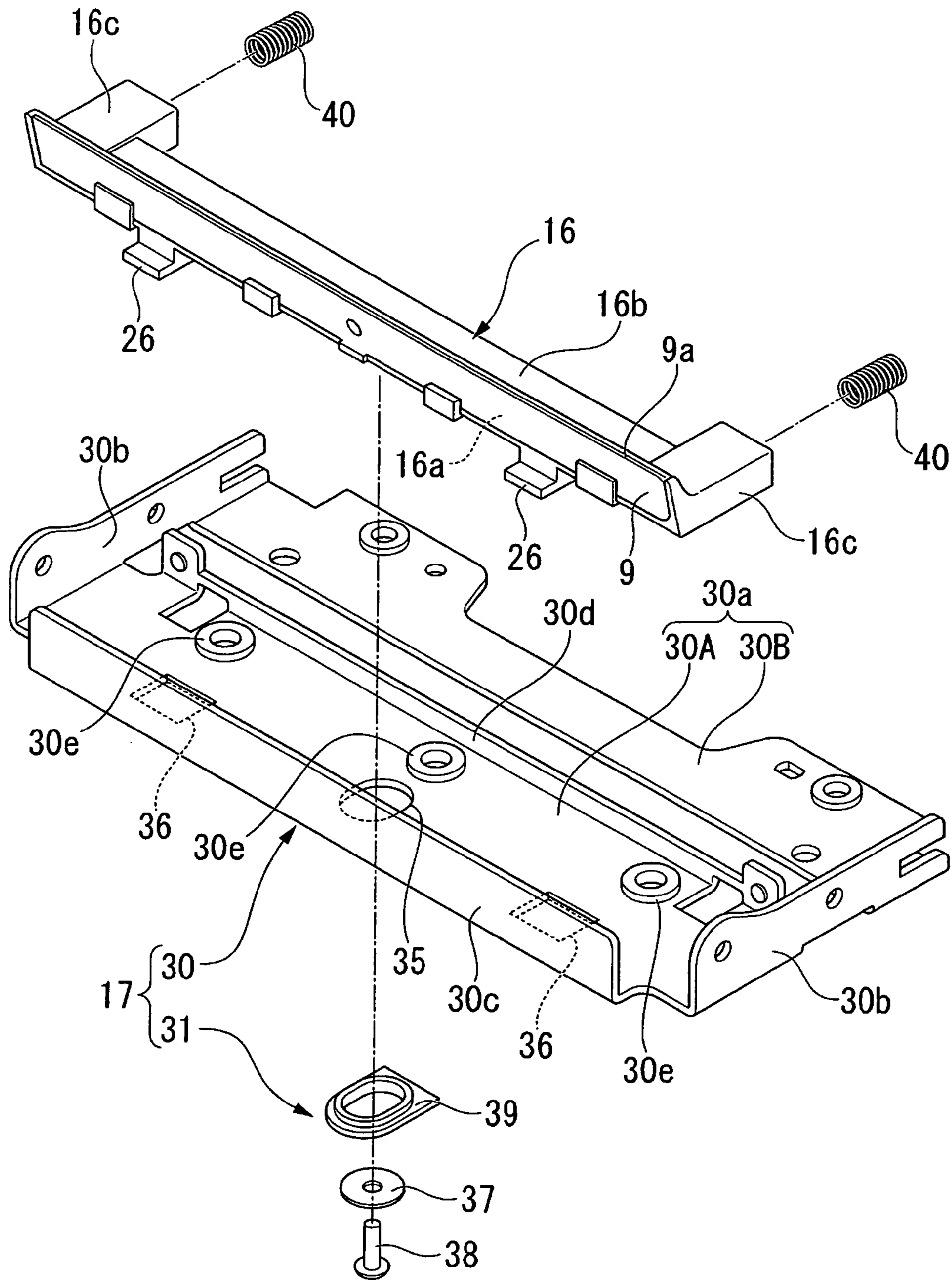

FIG. 14

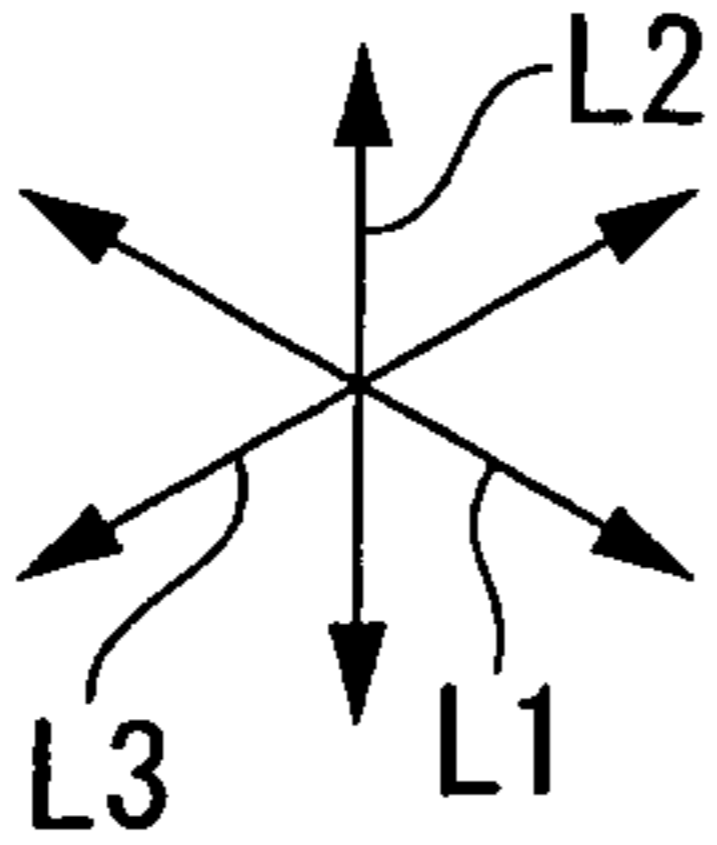
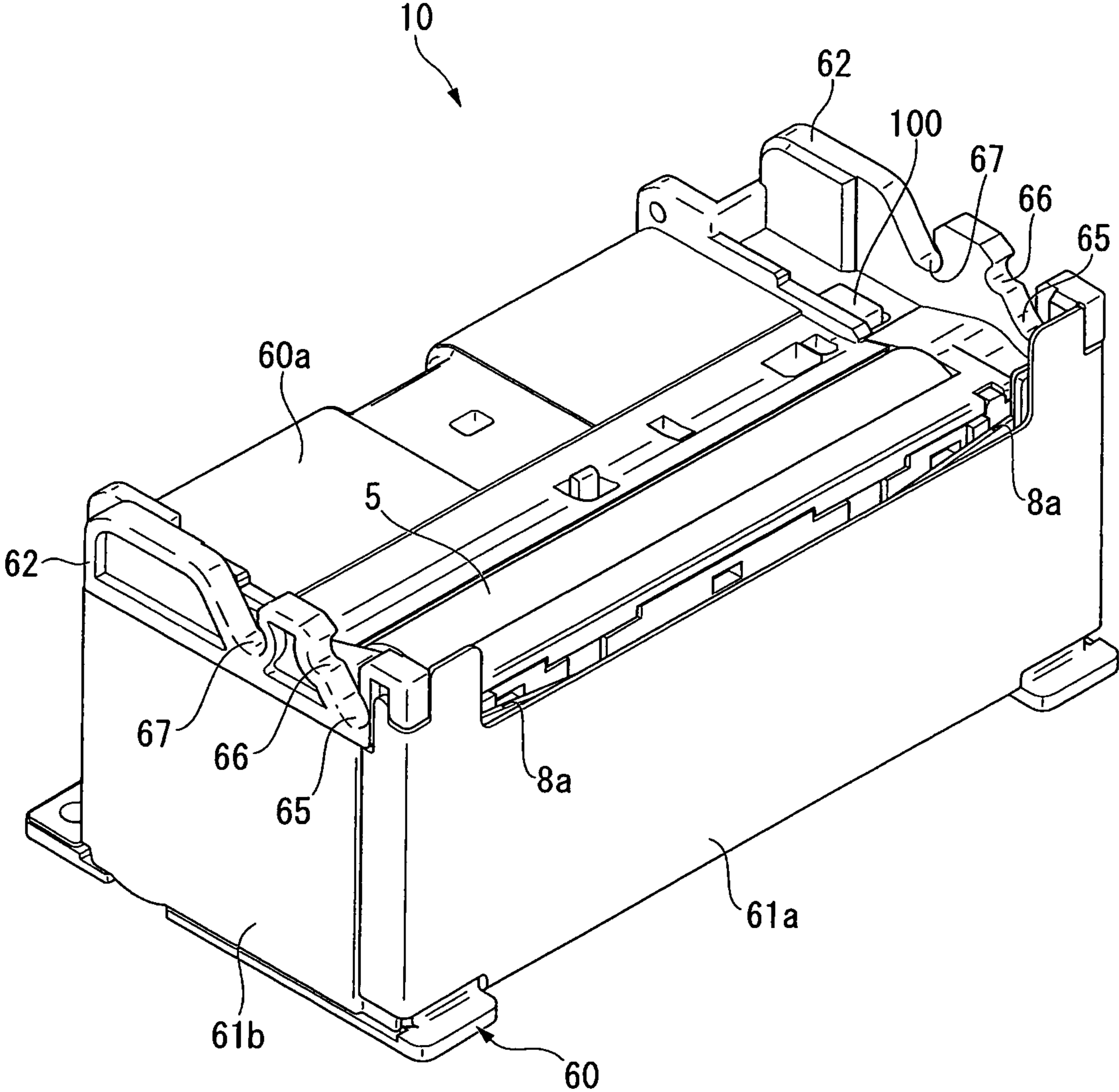

FIG. 15

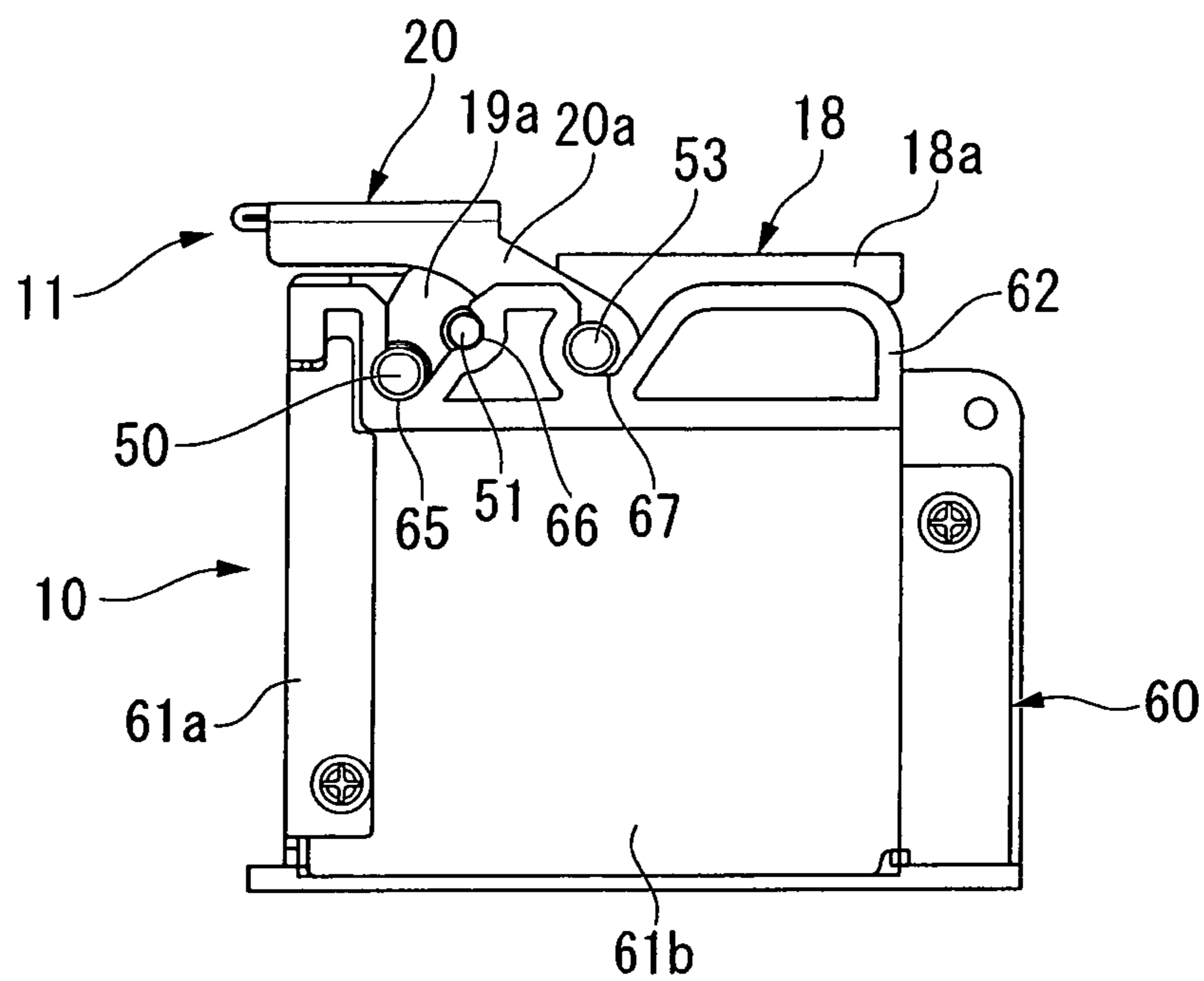

FIG. 16

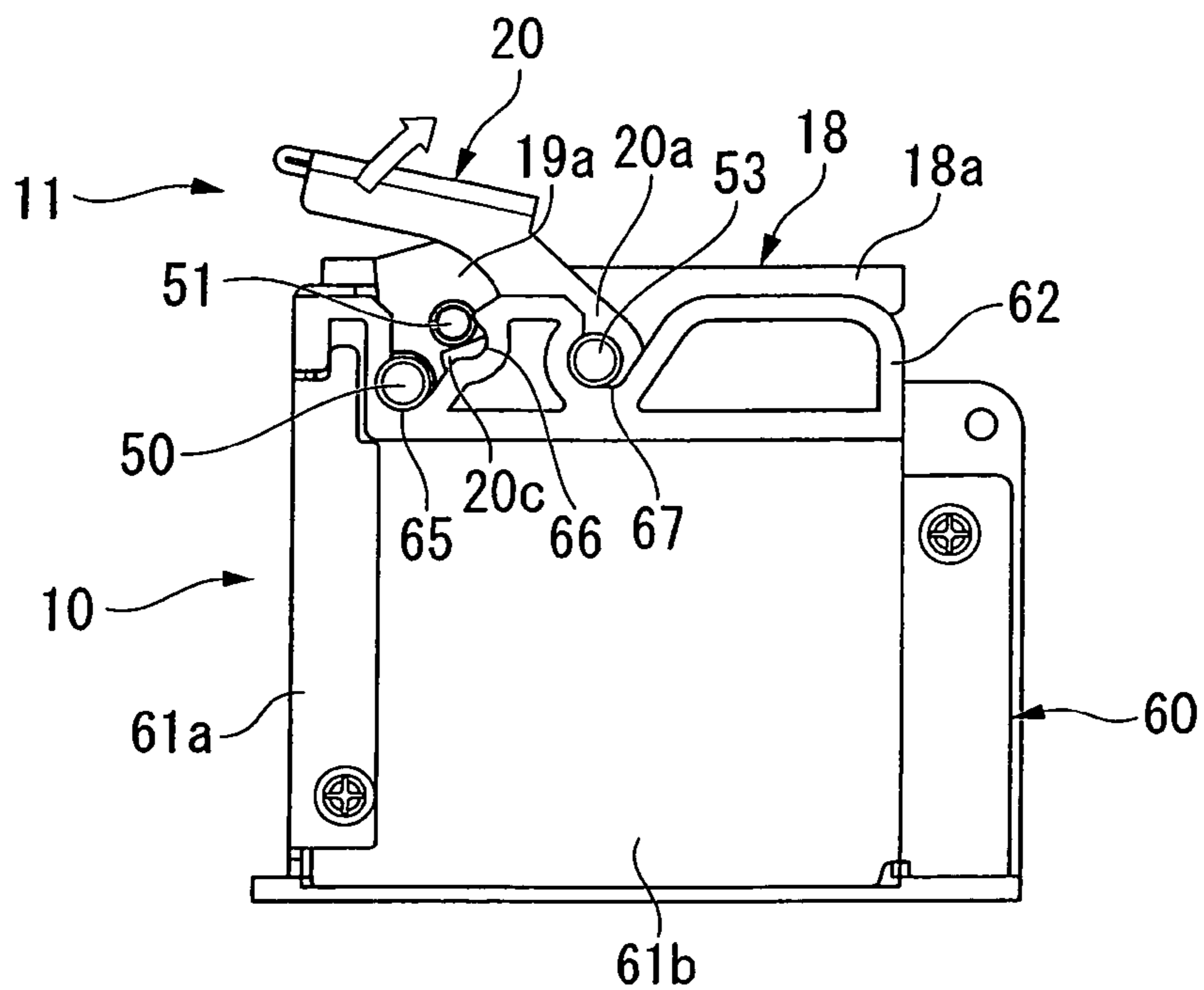

FIG. 17

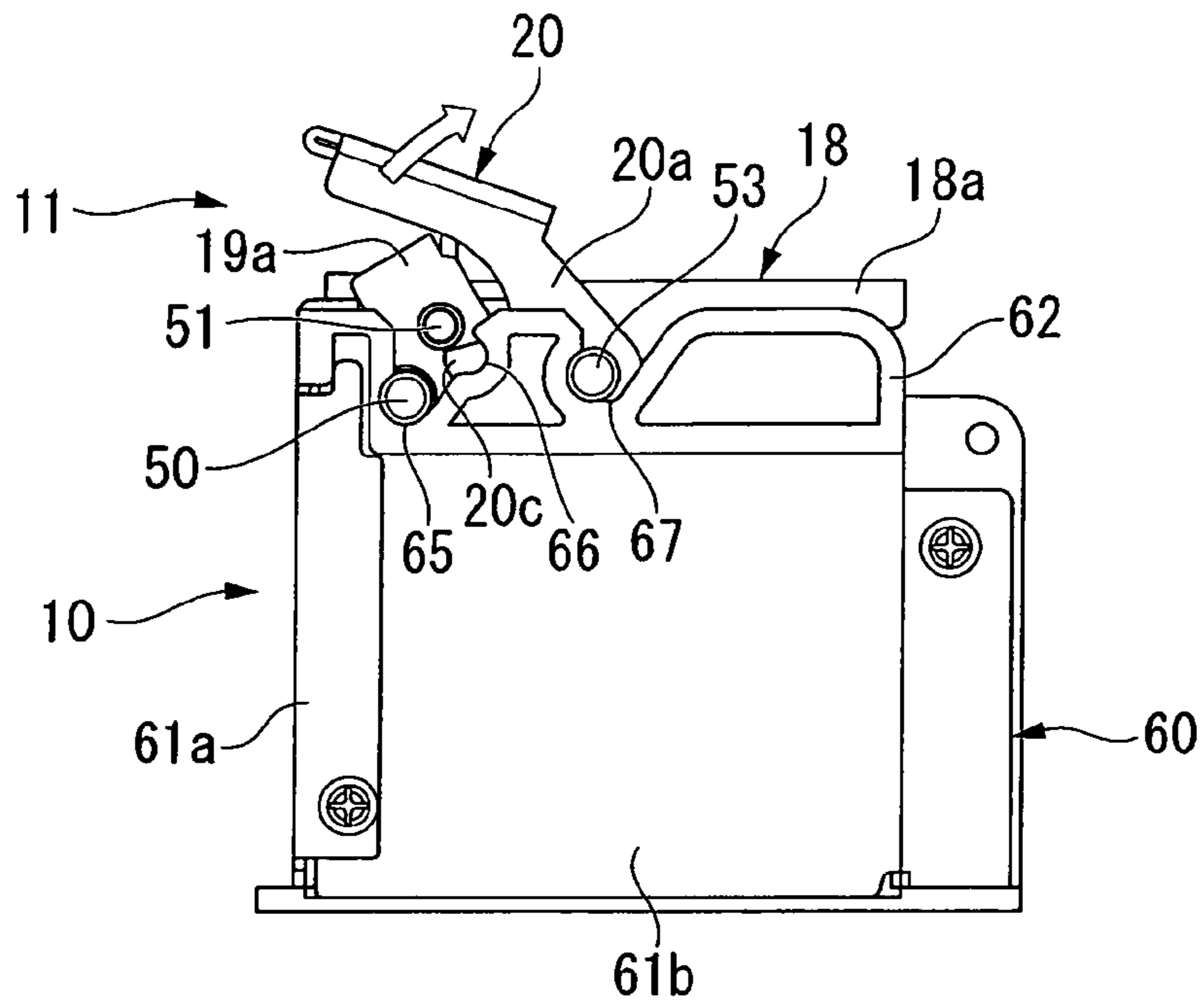

FIG. 18

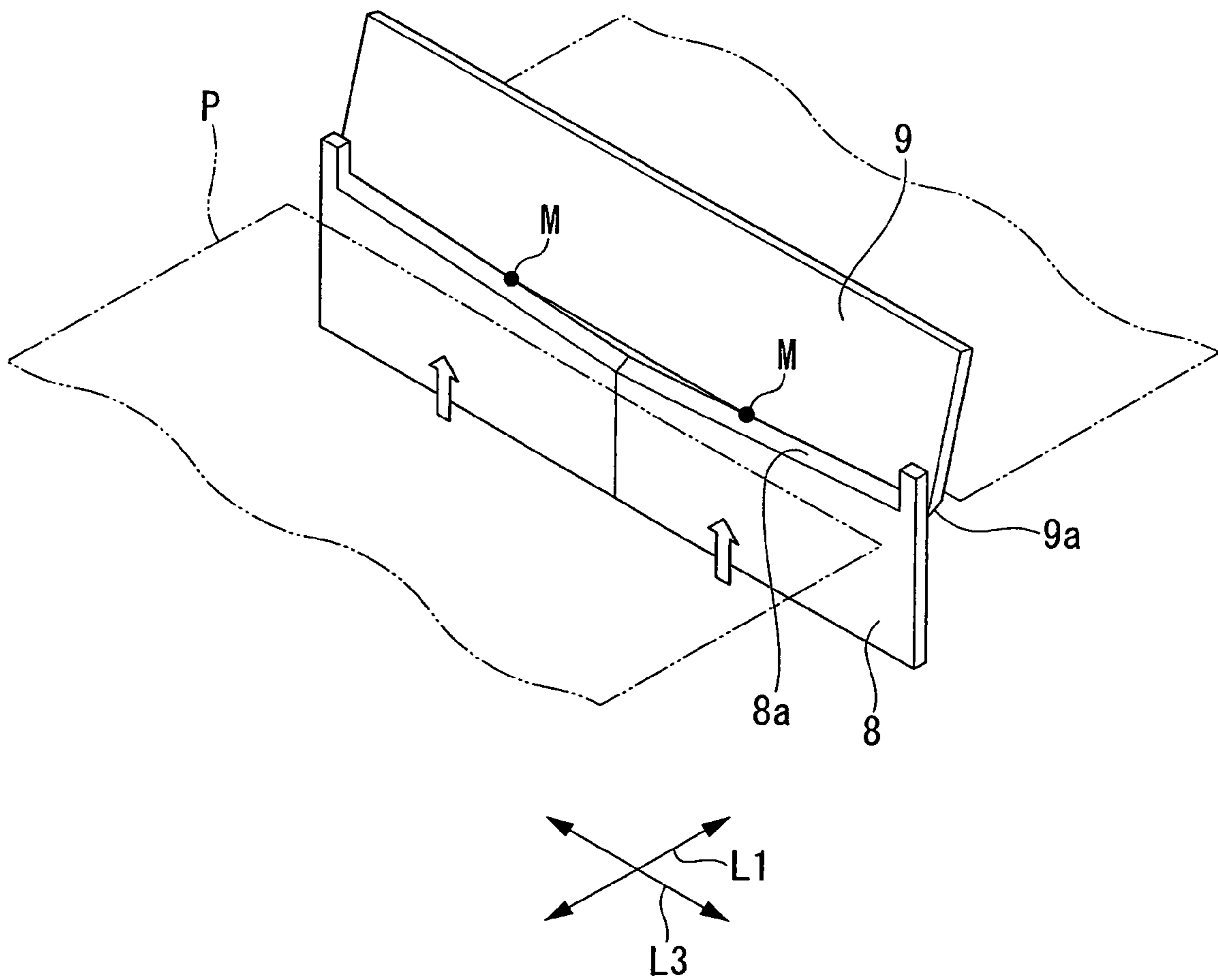

FIG. 19

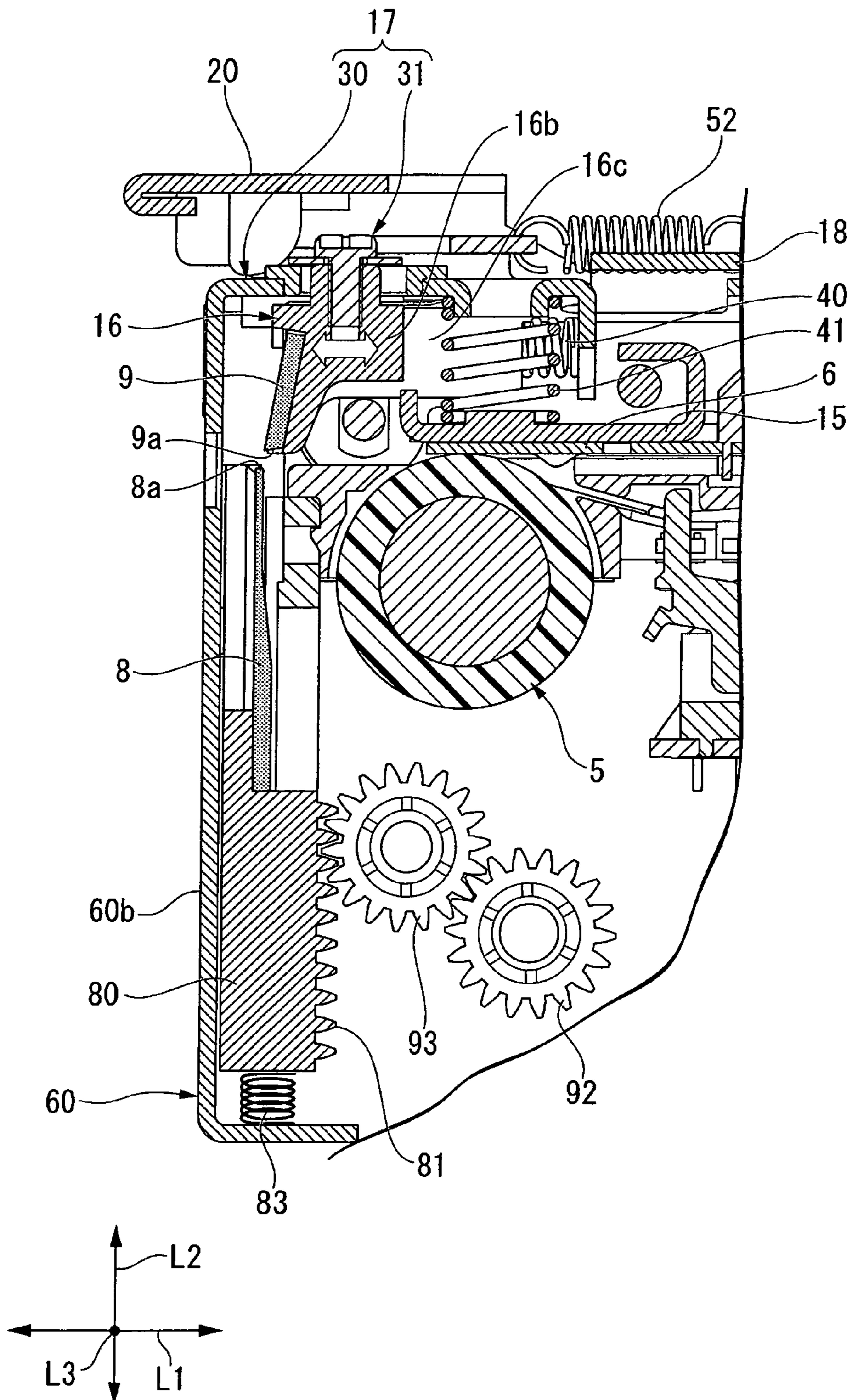

FIG. 20

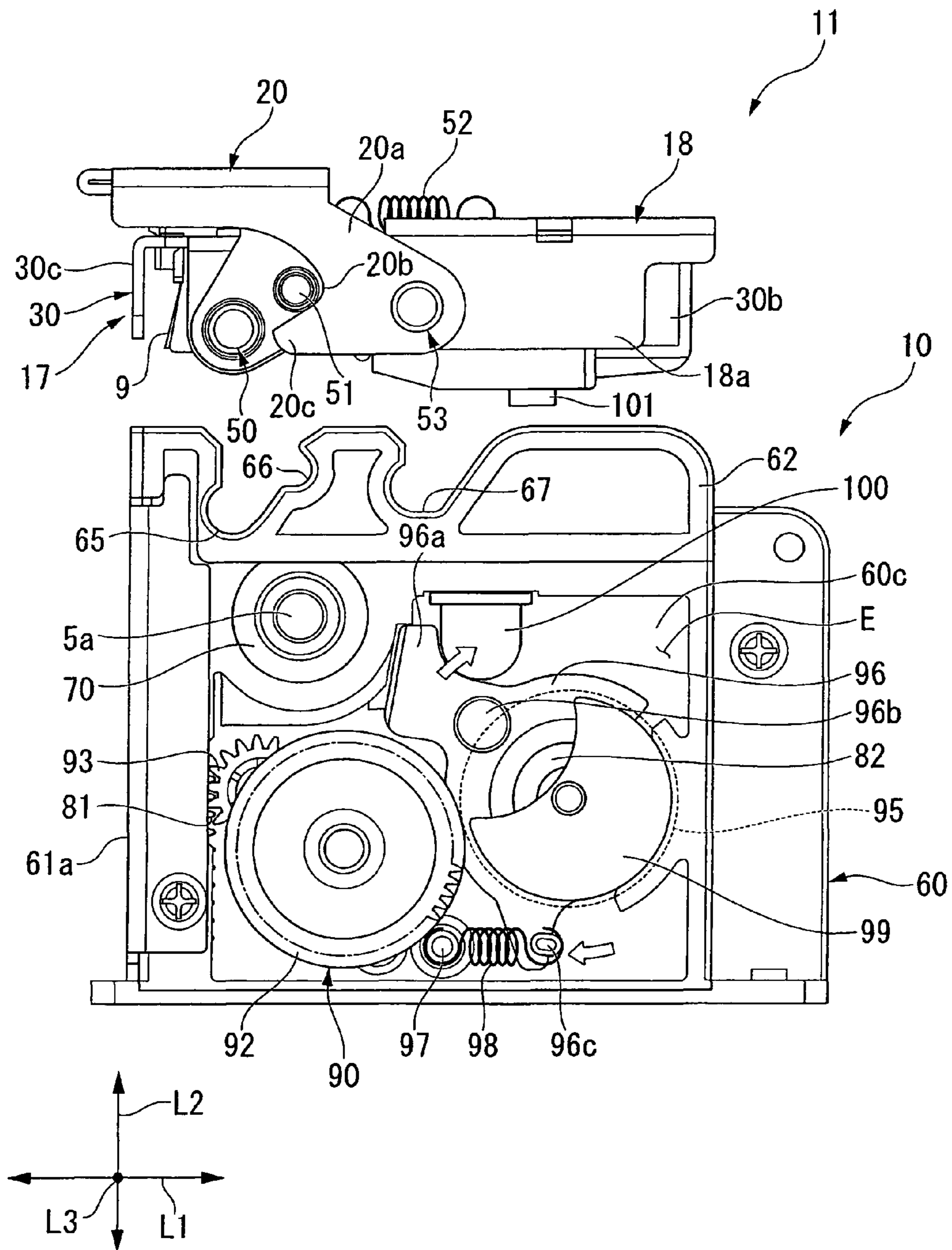

FIG. 21

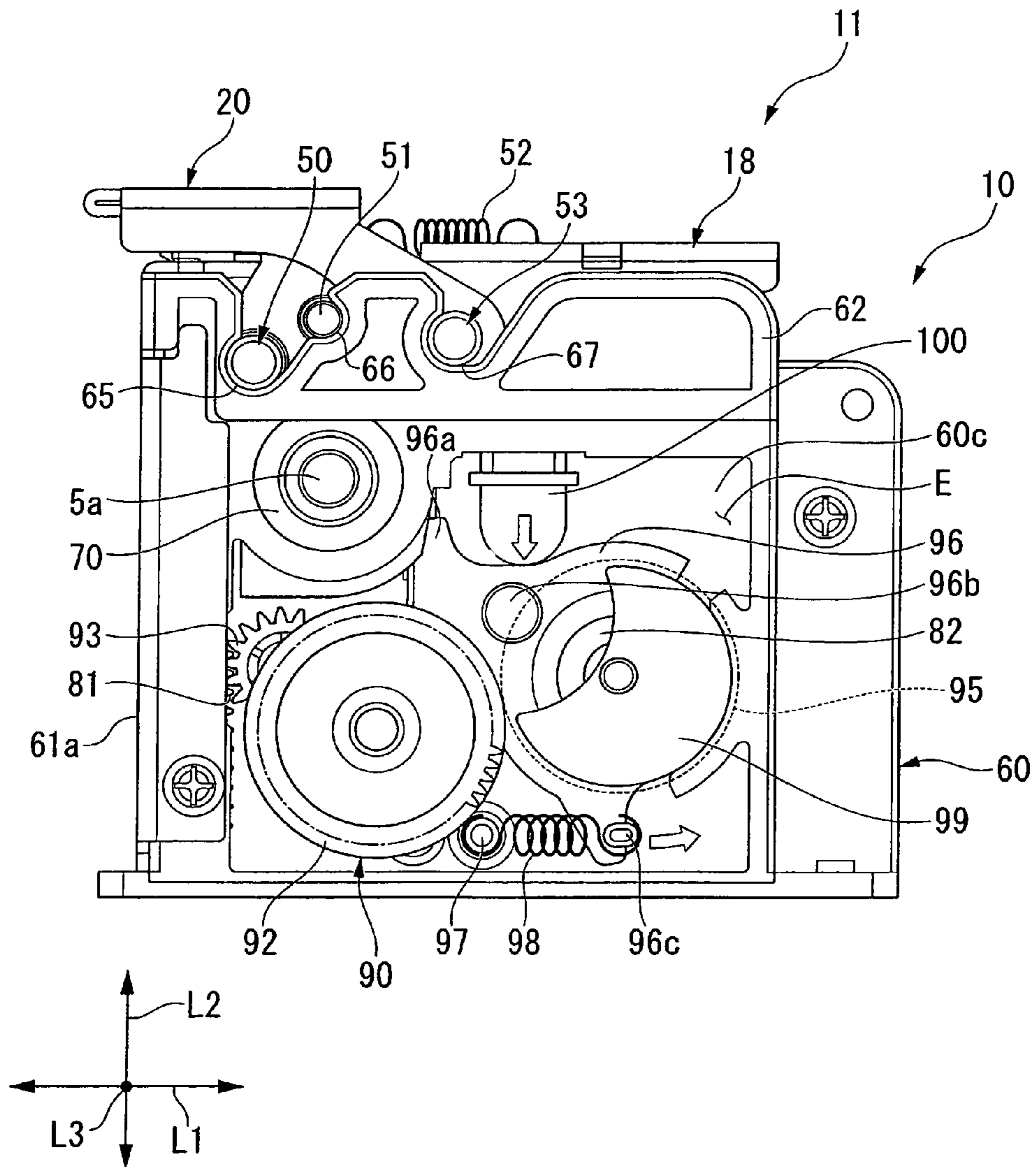

FIG. 22

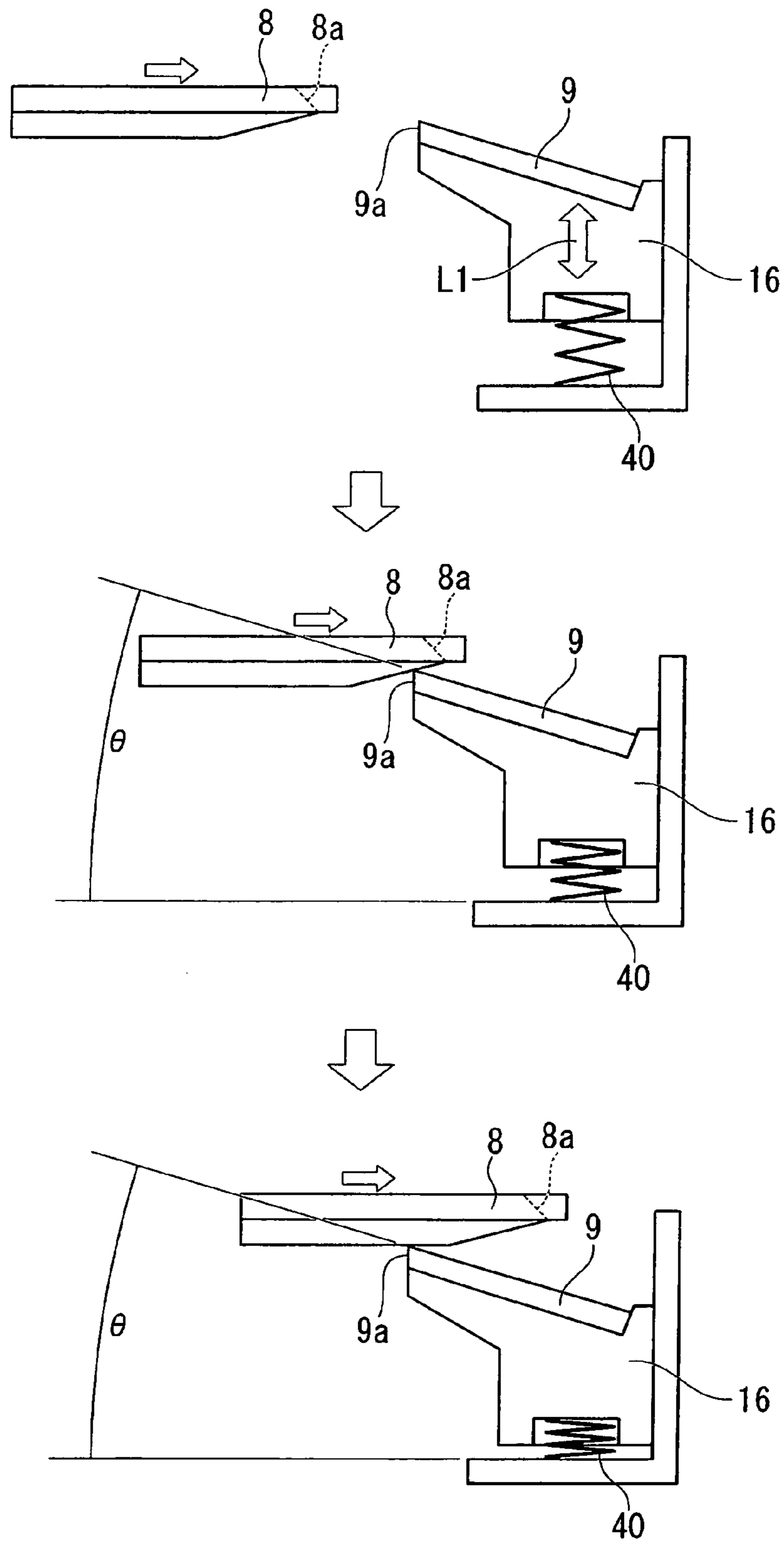

FIG. 23

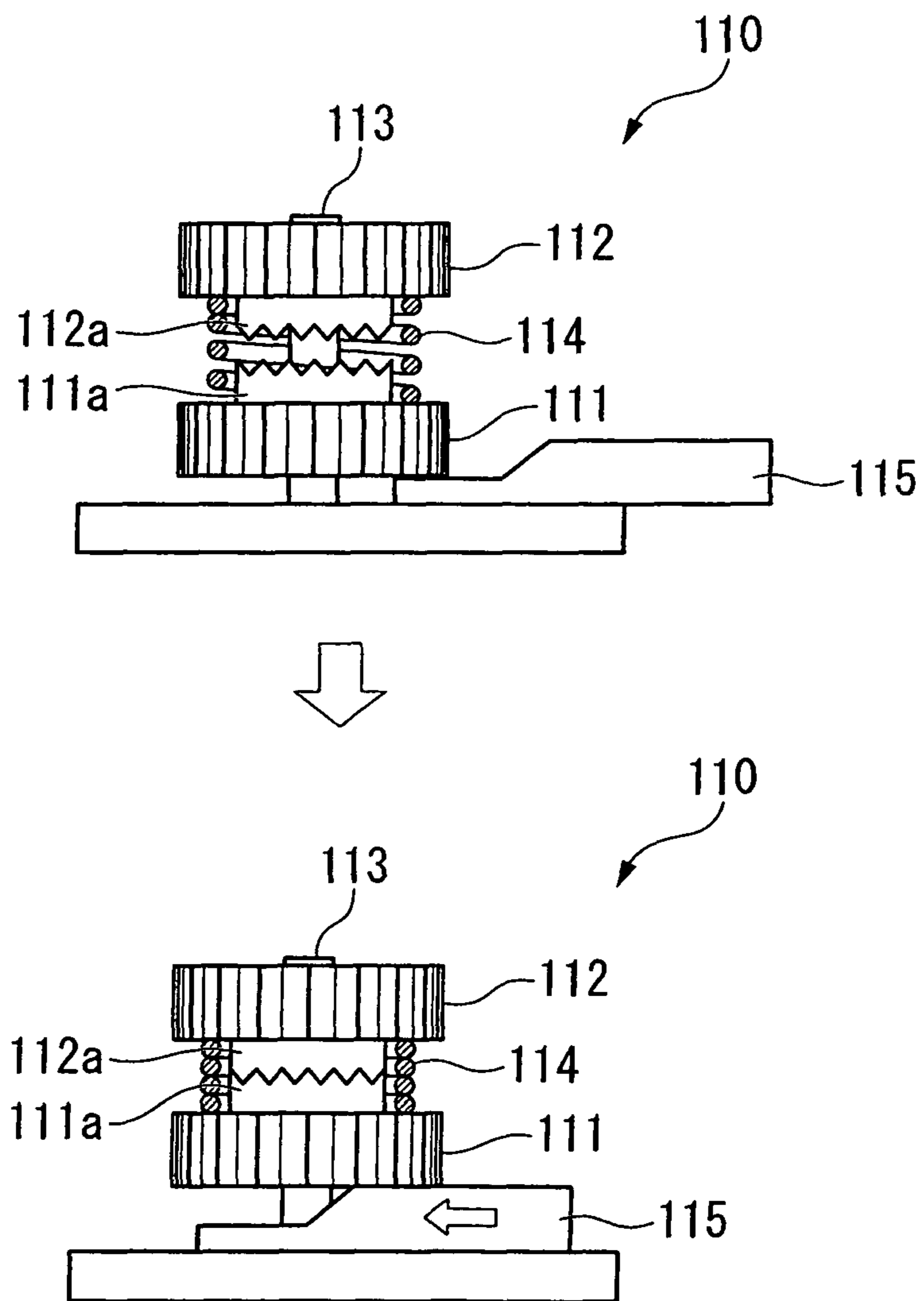
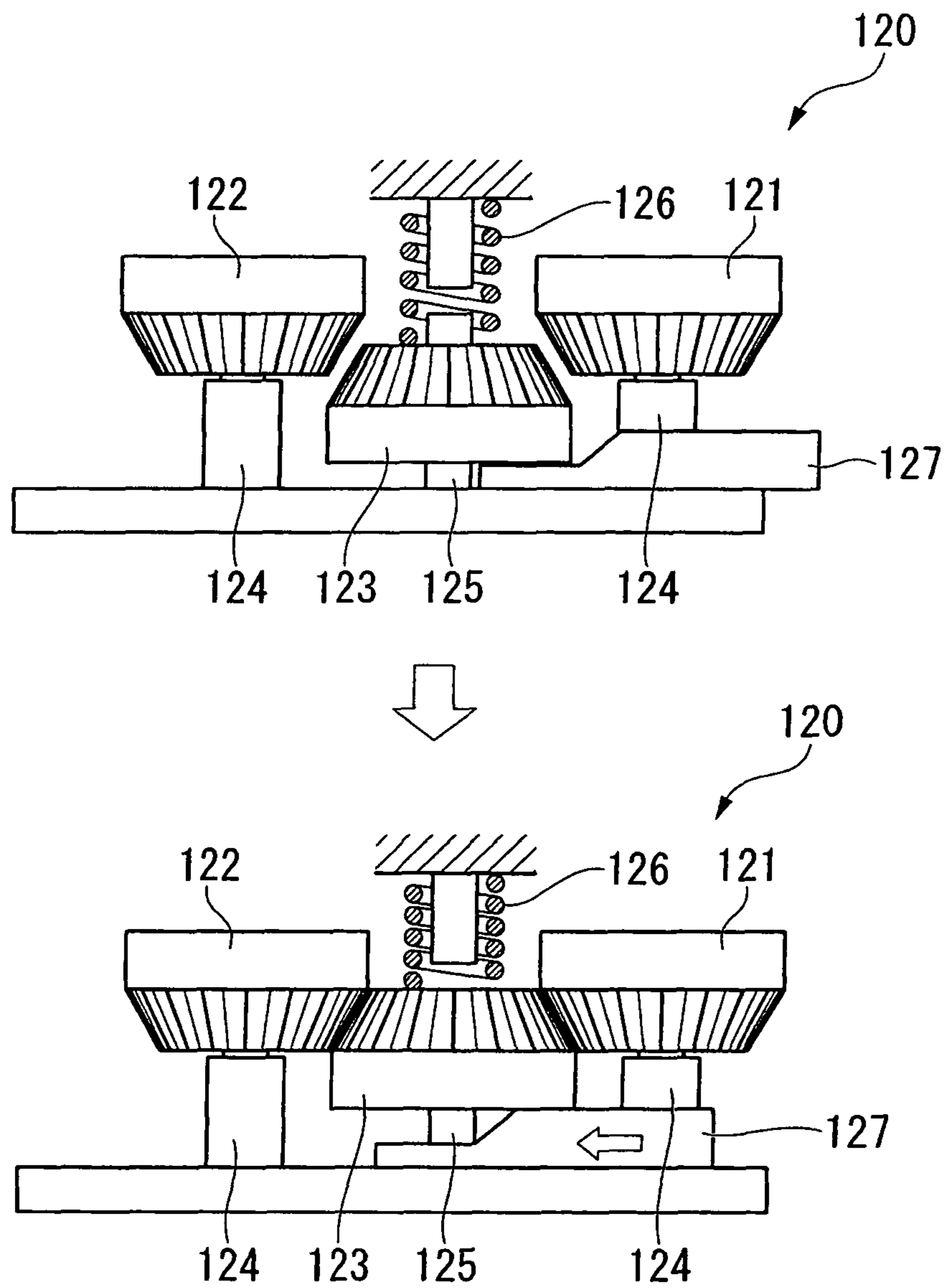

FIG. 24



PRINTER WITH A CUTTER

BACKGROUND OF THE INVENTION

1. Field of the Invention

The present invention relates to a printer with a cutter capable of appropriately cutting a recording sheet pulled out of a paper roll after performing printing on the recording sheet.

2. Description of the Related Art

In recent years, a number of various kinds of thermal printers have been provided which perform printing by pressing a thermal head against a special recording sheet (heat-sensitive sheet) that develops color when applying heat to the sheet. In particular, the thermal printers enable smooth character printing and colorful graphic printing without using toner, ink, etc., and hence the thermal printers are used preferably for printing of various labels, sales checks, tickets, and the like.

As typified by the thermal printers, a number of printers with a cutter having a cutter mechanism for cutting a printed recording sheet are known. The cutter mechanism generally includes a fixed blade and a movable blade capable of being slid with respect to the fixed blade. In particular, the movable blade is slid so as to ride on the fixed blade. Thus, the cutter mechanism can cut the recording sheet while sandwiching the recording sheet between both the blades like scissors.

Incidentally, as a structure in which the cutter mechanism of this type is incorporated into a printer, an integral type structure and a separation type structure are known. Specifically, in the integral type structure, a cutter unit including a movable blade and a fixed blade integrated with each other is incorporated to a main unit. In the separation type structure, a detachable unit is detachably provided to the main unit, and the fixed blade is incorporated into one of the main unit and the detachable unit and the movable blade is incorporated into the other of the main unit and the detachable unit. Thus, it is possible to separably combine the fixed blade and the movable blade with each other.

As disclosed in, for example, Japanese Patent Application Laid-open No. 2000-272200, as a printer provided with the separation type cutter mechanism, there is known a printer in which the movable blade is provided on the main unit side and the fixed blade is provided on the detachable unit side, and in which the detachable unit is capable of turning in a direction substantially orthogonal to a sliding direction of the movable blade.

Incidentally, in the printer with a cutter, there may arise various kinds of problems in that foreign matters get caught between the fixed blade and the movable blade, that the recording sheet gets caught (so-called paper jam), that blades bite each other during a cutting operation, and that the movable blade is stopped halfway through sliding due to malfunction or the like.

At this time, in the case of the cutter mechanism having the integral type structure, it is necessary to forcibly retreat the movable blade through manual manipulation of a releasing knob or the like for sliding the movable blade, to thereby separate the movable blade from the fixed blade. Therefore, an operation of restoring the movable blade requires time and effort, and hence a substantial burden is imposed on a user. In addition, when setting the recording sheet, it is necessary to pass the recording sheet through a gap between the movable blade and the fixed blade, and hence workability is poor.

In contrast, in the printer described in Japanese Patent Application Laid-open No. 2000-272200, the detachable unit is allowed to be separated from the main unit, and hence the printer is excellent in workability when setting the recording

sheet. However, in the case where the movable blade is stopped halfway due to paper jam, or in the case where the movable blade is stopped halfway through sliding due to biting between the blades, the malfunction, or the like, the movable blade remains covering the fixed blade (riding on the fixed blade). Accordingly, even when it is intended to separate the detachable unit from the main unit through causing the detachable unit to turn in the direction substantially orthogonal to the sliding direction of the movable blade, it is difficult to separate the detachable unit from the main unit because the fixed blade is hindered by the movable blade. Therefore, similarly to the case of the above-mentioned integral type, it is necessary to manually and forcibly retreat the movable blade, and hence a substantial burden is imposed on a user.

In addition, even when the main unit and the detachable unit are separated from each other, the movable blade may slide accidentally, and hence the printer is in need of improvement in terms of safety.

SUMMARY OF THE INVENTION

The present invention has been made in view of the above-mentioned circumstances, and an object of the present invention is therefore to provide a printer with a cutter excellent in safety, which is capable of separating a main unit and a detachable unit from each other while a movable blade is automatically restored even when the movable blade is stopped halfway through sliding, and capable of regulating the slide of the movable blade automatically restored at the time of separation of both the units.

In order to achieve the above-mentioned object, the present invention provides the following measures.

(1) The present invention provides a printer with a cutter for cutting a recording sheet after printing is performed on the recording sheet, the printer including: a main unit which supports one of a recording head and a platen roller, and incorporates a movable blade which is slidable; and a detachable unit which supports another of the recording head and the platen roller, incorporates a fixed blade for cutting the recording sheet while sandwiching the recording sheet together with the movable blade when the movable blade slides, and is separably combined with the main unit, the main unit including: a movable blade holder for holding the movable blade; a reciprocating mechanism for causing the movable blade holder to linearly reciprocate along with rotation of a drive gear coupled to a movable blade motor; a biasing member for biasing the movable blade through the movable blade holder in a direction of separating the movable blade from the fixed blade; and a gear train mechanism for coupling the drive gear and the reciprocating mechanism to each other to transmit a rotational force of the drive gear to the reciprocating mechanism when the detachable unit is combined, and for disconnecting the drive gear and the reciprocating mechanism from each other when the detachable unit is separated, the detachable unit moving close to and away from the main unit along a sliding direction of the movable blade when the detachable unit is combined with and separated from the main unit.

According to the printer with a cutter of the present invention, when the detachable unit is combined with the main unit, the recording head and the platen roller sandwich the recording sheet, and are arranged to be opposed to each other in a contact state. Further, the gear train mechanism couples the drive gear and the reciprocating mechanism to each other, and a state in which the rotational force of the drive gear is capable of being transmitted to the reciprocating mechanism is provided.

Then, after the printing is performed on the recording sheet by the recording head while the recording sheet is fed by the platen roller, when the recording sheet thus printed is cut, the movable blade motor is driven to rotate the drive gear. As a result, the rotational force is transmitted to the reciprocating mechanism by the gear train mechanism. In this way, the reciprocating mechanism linearly reciprocates, and thus the reciprocating mechanism is capable of causing the movable blade held by the movable blade holder to slide with respect to the fixed blade. Through this sliding, the movable blade is capable of overlapping the fixed blade so as to ride on the fixed blade, and hence the movable blade is capable of cutting the recording sheet while sandwiching the same together with the fixed blade. As a result, it is possible to use the recording sheet thus cut as a sales check, a ticket, or the like.

Here, the case where the movable blade is stopped halfway through sliding due to paper jam or the like is described.

In this case, though the movable blade remains riding on the fixed blade (covering the fixed blade), it is possible to move the detachable unit close to and away from the main unit along the sliding direction of the movable blade. Thus, even when the movable blade is stopped halfway through sliding, it is possible to separate the detachable unit from the main unit, and to pull out the fixed blade so as to cause the fixed blade to slide on the movable blade.

Therefore, even in the case where the movable blade is stopped halfway through sliding, unlike the conventional printer, it is possible to easily separate the movable blade and the fixed blade from each other. Then, it is possible to immediately perform operations for recovery from various inconveniences, such as paper jams.

In particular, when the detachable unit is separated from the main unit, the gear train mechanism mechanically disconnects the drive gear and the reciprocating mechanism from each other along with separation of the detachable unit. In this way, the reciprocating mechanism assumes a free state of being disconnected from the movable blade motor. Incidentally, the biasing member biases the movable blade through the movable blade holder in the direction of separating the movable blade from the fixed blade. Thus, when the reciprocating mechanism assumes the free state, the movable blade holder moves through reception of a force applied by the biasing member. Therefore, it is possible to separate the movable blade from the fixed blade, to thereby automatically restore the movable blade to an initial position prior to sliding. In addition, it is possible to prevent a cutting edge of the movable blade from remaining exposed at the time of separation of the detachable unit.

What is more, as described above, the reciprocating mechanism and the drive gear are disconnected from each other. Thus, even when the movable blade motor is mistakenly driven at the time of separation of the detachable unit, the movable blade does not slide because the reciprocating mechanism does not linearly move. Therefore, it is possible to obtain an interlocking structure in which the slide of the movable blade is regulated, and hence the movable blade is continuously allowed to reliably wait at the initial position prior to sliding. With this configuration, it is possible to achieve increased safety, and to provide a user-friendly printer.

(2) The present invention provides a printer with a cutter, in which: the recording head is provided on the detachable unit side; and the platen roller is provided on the main unit side.

According to the printer with a cutter of the present invention, it is possible to provide, on the main unit side, the movable blade and the platen roller which are likely to have a complicated structure, and to provide, on the detachable unit

side, the recording head and the fixed blade which are likely to have a simple structure. Thus, it is easy to achieve reduction in size and weight of the detachable unit. Therefore, it is possible to provide a printer excellent in attachment/detachment operability.

According to the printer with a cutter of the present invention, even when the movable blade is stopped halfway through sliding, it is possible to separate the main unit and the detachable unit from each other while the movable blade is automatically restored. In addition, it is possible to regulate the slide of the automatically-restored movable blade at the time of separation of both the units, and hence the printer with a cutter of the present invention is excellent in safety.

BRIEF DESCRIPTION OF THE DRAWINGS

In the accompanying drawings:

FIG. 1 is a cross-sectional view of a thermal printer with an open/close door closed according to an embodiment of the present invention;

FIG. 2 is a cross-sectional view of the thermal printer with the open/close door opened from the state illustrated in FIG. 1;

FIG. 3 is a perspective view illustrating a state in which a detachable unit is mounted on a main unit;

FIG. 4 is a perspective view illustrating a state in which the detachable unit is separated from the state illustrated in FIG. 3, with a side cover of the main unit removed;

FIG. 5 is a perspective view illustrating a state in which the detachable unit is separated from the state illustrated in FIG. 3, with a front cover of the main unit removed;

FIG. 6 is a perspective view of an outer appearance of the detachable unit;

FIG. 7 is a side view of the detachable unit illustrated in FIG. 6;

FIG. 8 is a perspective view illustrating a state in which a fixed blade holder cover, a latch cover, and a release cover are removed from the state illustrated in FIG. 6;

FIG. 9 is a view of an inner structure in which the main unit is combined with the detachable unit, with a movable blade riding on a fixed blade;

FIG. 10 is a view illustrating a positional relationship between the fixed blade and the movable blade;

FIG. 11 is a perspective view illustrating a state in which a holder support frame illustrated in FIG. 8 is reversed;

FIG. 12 is a view illustrating a state in which each component is disassembled from the state illustrated in FIG. 8;

FIG. 13 is a view illustrating a state in which each component is disassembled from the state illustrated in FIG. 11;

FIG. 14 is a perspective view of the main unit;

FIG. 15 is a view illustrating a state in which the main unit is combined with the detachable unit when seen from a side;

FIG. 16 is a view illustrating a state in which the release cover is rotated backward from the state illustrated in FIG. 15, and a lock pin is pushed up by a hook portion;

FIG. 17 is a view illustrating a state in which the lock pin is pushed up further from the state illustrated in FIG. 16;

FIG. 18 is a view illustrating a state in which the movable blade is slid from the state illustrated in FIG. 10;

FIG. 19 is a view of a part of an inner structure in a main frame;

FIG. 20 is a side view of the main unit illustrated in FIG. 4, with a first gear removed;

FIG. 21 is a side view of the main unit illustrated in FIG. 3, with the first gear removed;

5

FIG. 22 is a schematic view illustrating how the movements of the movable blade and the fixed blade held by a fixed blade holder change along with the proceeding of the slide of the movable blade;

FIG. 23 is a view of a modification according to the present invention, illustrating another configuration of a gear train mechanism; and

FIG. 24 is a view of a modification according to the present invention, illustrating still another configuration of the gear train mechanism.

DETAILED DESCRIPTION OF THE PREFERRED EMBODIMENT

Hereinafter, an embodiment according to the present invention is described with reference to FIGS. 1 to 24. In this embodiment, a thermal printer is described as an example of a printer.

As illustrated in FIGS. 1 and 2, the thermal printer according to this embodiment is a so-called clamshell printer capable of performing printing on a recording sheet P pulled out of a paper roll R, appropriately cutting the recording sheet P, and utilizing the cut piece of the recording sheet P as a ticket, a sales check, etc.

The thermal printer mainly includes a casing 2, an open/close door 3 provided so as to be opened/closed with respect to the casing 2, a cutter mechanism 4, a platen roller 5, and a thermal head (recording head) 6.

FIG. 1 is a cross-sectional view of a thermal printer 1 with the open/close door 3 closed. FIG. 2 is a cross-sectional view of the thermal printer 1 with the open/close door 3 opened.

Further, in this embodiment, in the state illustrated in FIG. 1, the left side, right side, upper side, and lower side with respect to the drawing sheet are defined as a front side, a back side, an upper side, and a lower side, respectively. It is assumed that the recording sheet P is fed in fore-and-aft directions L1. Further, it is also assumed that a direction orthogonal to the fore-and-aft directions L1 and up-and-down directions L2 is right-and-left directions L3.

The casing 2 is molded with a plastic or a metal material, and is formed in a box-shape with an insertion port 2a opened in an upper portion. In the casing 2, a mounting board 2b for mounting the paper roll R inserted through the insertion port 2a is provided. The mounting board 2b is formed so as to be curved in an arcuate shape, and allows the paper roll R in a cylindrical shape to be mounted thereon stably.

The open/close door 3 is coupled so as to be opened/closed via a hinge portion 7 and is attached to the upper portion of the casing 2. The open/close door 3 is designed so as to be opened/closed within a predetermined angle range from the closed state illustrated in FIG. 1 to the opened state illustrated in FIG. 2. Then, as illustrated in FIG. 2, when the open/close door 3 is opened, the insertion port 2a appears, and thus, the paper roll R can be inserted in the casing 2 or taken out of the casing 2.

Further, as illustrated in FIG. 1, the thermal printer 1 is designed so that a slight gap is formed between the tip end of the open/close door 3 and the casing 2 when the open/close door 3 is closed. The recording sheet P fed from the inside of the casing 2 is to be pulled out, utilizing the gap. That is, the gap functions as a discharge port 2c of the recording sheet P.

The open/close door 3 is designed so as to be locked with respect to the casing 2 automatically with a lock mechanism (not shown) when the open/close door 3 is closed. The lock mechanism can be unlocked with one-touch from outside of the casing 2, and hence, the open/close door 3 can be opened quickly.

6

The cutter mechanism 4 includes a main unit 10 which supports the platen roller 5 and incorporates a movable blade 8 capable of being slid, and a detachable unit 11 which supports the thermal head 6, incorporates a fixed blade 9 for cutting the recording sheet P while sandwiching the recording sheet P together with the movable blade 8 during the slide of the movable blade 8, and is separably combined with the main unit 10.

The main unit 10 of both the units 10, 11 is provided on the casing 2 side. Specifically, the main unit 10 is fixed in an accommodating chamber 2d formed in front of the mounting board 2b on which the paper roll R is to be mounted. In FIGS. 1 and 2, the movable blade 8 and the platen roller 5 are illustrated as representatives.

On the other side, the detachable unit 11 is provided on an inner surface on a tip end side of the open/close door 3. Therefore, the detachable unit 11 moves along with the opening/closing operation of the open/close door 3, and thus, is combined with the main unit 10 or separated from the main unit 10.

FIGS. 1 and 2 illustrate the fixed blade 9 and the thermal head 6 as representatives.

The main unit 10 and the detachable unit 11 are to be combined as illustrated in FIG. 3 when the open/close door 3 is closed. This allows the main unit 10 to be combined with the detachable unit 11 so that the movable blade 8 and the fixed blade 9 are placed to be opposed to each other with the recording sheet P sandwiched therebetween as illustrated in FIG. 1, and the thermal head 6 is held in contact with the platen roller 5 under an appropriate contacting pressure. Further, when the open/close door 3 is opened, the detachable unit 11 is separated from the main unit 10, as illustrated in FIGS. 4 and 5. This allows the movable blade 8 and the fixed blade 9 to be moved away from each other and allows the thermal head 6 to be separated from the platen roller 5.

FIG. 3 is a perspective view illustrating a state in which the detachable unit 11 is mounted on the main unit 10. FIG. 4 is a perspective view illustrating a state in which a side cover 61b of the main unit is removed, and illustrating a state in which the detachable unit 11 is separated from the state illustrated in FIG. 3. FIG. 5 is a perspective view illustrating a state in which a front cover 61a of the main unit is removed, and illustrating a state in which the detachable unit 11 is separated from the state illustrated in FIG. 3.

Hereinafter, the configurations of both the units 10, 11 are described in detail in the order of the detachable unit 11 and the main unit 10.

(Detachable Unit)

First, the detachable unit 11 moves to rotate about the hinge portion 7 along with the opening/closing operation of the open/close door 3, as described above. However, the detachable unit 11 moves close to and away from the main unit 10 in the sliding direction (up-and-down directions L2) of the movable blade 8 immediately before being combined with the main unit 10 and immediately after being separated from the main unit 10.

As illustrated in FIGS. 6 to 9, the detachable unit 11 according to this embodiment includes the thermal head 6, a head support frame 15 supporting the thermal head 6, the fixed blade 9 placed on a downstream side in a conveying direction of the recording sheet P with respect to the thermal head 6, a fixed blade holder 16 holding the fixed blade 9, a holder support frame (holder support member) 17 supporting the fixed blade holder 16 movably, a fixed blade holder cover 18 covering a back side of the holder support frame 17, a latch cover (latch member) 19 covering a front side of the holder

7

support frame 17, and a release cover (release member) 20 further covering the latch cover 19.

FIG. 6 is a perspective view of an outer appearance of the detachable unit 11. FIG. 7 is a side view of the detachable unit 11 illustrated in FIG. 6. FIG. 8 is a perspective view illustrating a state in which the fixed blade holder cover 18, the latch cover 19, and the release cover 20 are removed from the state illustrated in FIG. 6. FIG. 9 is an internal structural view illustrating the case where the main unit 10 and the detachable unit 11 are combined with each other, and illustrating a state in which the movable blade 8 rides on the fixed blade 9.

As illustrated in FIG. 10, the fixed blade 9 is a blade in a plate shape extending in the right-and-left directions L3 that correspond to a width direction of the recording sheet P, with one side of both parallel sides being a cutting edge 9a and the other side being a root portion. The blade width direction of the fixed blade 9 refers to the longitudinal direction extending in the width direction (right-and-left directions L3) of the recording sheet P. FIG. 10 illustrates a positional relationship between the fixed blade 9 and the movable blade 8.

As illustrated in FIGS. 1, 2, and 9, the fixed blade 9 is held by the fixed blade holder 16 so that the cutting edge 9a is directed downward to be opposed to the sheet surface of the recording sheet P, when the detachable unit 11 is attached to the main unit 10 with the open/close door 3 closed.

As illustrated in FIG. 9, the fixed blade holder 16 is a holder holding the fixed blade 9 in an inclined state (inclined forward from the root portion to the cutting edge 9a) with respect to the movable blade 8 so that the cutting edge 9a of the fixed blade 9 forms a predetermined cutting angle θ with respect to a cutting edge 8a of the movable blade 8 when the detachable unit 11 is attached to the main unit 10 with the open/close door 3 closed.

As illustrated in FIGS. 9 and 11 to 13, specifically, the fixed blade holder 16 is integrally formed of a holder body 16b which extends in the blade width direction of the fixed blade 9 and in which a mounting surface 16a on which the fixed blade 9 is mounted and fixed is formed, and leg portions 16c that protrude backward from both right and left ends of the holder body 16b.

FIG. 11 is a perspective view illustrating a state in which the holder support frame 17 illustrated in FIG. 8 is reversed. FIG. 12 illustrates a state in which each component is disassembled from the state illustrated in FIG. 8. FIG. 13 illustrates a state in which each component is disassembled from the state illustrated in FIG. 11.

The mounting surface 16a of the holder body 16b is formed as an inclined surface inclined gradually to the front side from an upper side to a lower side, and is designed so as to hold in an inclined state the fixed blade 9 that is mounted and fixed as described above. The upper surface of the holder body 16b is formed as a sliding surface that slidably comes into contact with a support frame 30 constituting the holder support frame 17 described later. At this time, on the upper surface of the holder body 16b, a boss 25 for connecting the support frame 30 to the holder body 16b, and two stopper hooks 26 regulating the movement amount of the holder body 16b are formed.

The boss 25 is formed at a position corresponding to the intermediate portion of the fixed blade 9 in the blade width direction on the upper surface of the holder body 16b. The two stopper hooks 26 are formed at a distance so as to interpose the boss 25 therebetween. The stopper hooks 26 are formed so that the hooks are directed to the front side.

The holder support frame 17 is orthogonal to the sliding direction (up-and-down directions L2) of the movable blade 8, and supports the fixed blade holder 16 movably in the orthogonal direction (fore-and-aft directions L1) in which the

8

cutting edge 9a of the fixed blade 9 moves close to and away from the cutting edge 8a of the movable blade 8, and includes the support frame 30 and a coupling member 31.

The support frame 30 is a frame-shaped plate to be superimposed on the upper surface side of the holder body 16b, and includes a ceiling wall portion 30a, side panels 30b bent downward from both right and left sides of the ceiling wall portion 30a, and a front panel 30c bent downward from the front side of the ceiling wall portion 30a.

The ceiling wall portion 30a is a plate in a rectangular shape when viewed from above, which is formed longer than the fixed blade holder 16 in the right-and-left directions L3 and the fore-and-aft directions L1, and is partitioned into a front ceiling wall portion 30A and a back ceiling wall portion 30B by a cutout portion extending in the right-and-left directions L3. Then, the fixed blade holder 16 is superimposed on the front ceiling wall portion 30A while being surrounded by the side panels 30b and the front panel 30c.

In the front ceiling wall portion 30A, a guide opening 35 formed in a vertically oriented manner in the orthogonal direction (fore-and-aft directions L1) is formed at a position opposed to the boss 25. Further, stopper openings 36 are formed so as to be aligned in the right-and-left directions L3 with the guide opening 35 interposed therebetween. Then, the fixed blade holder 16 is superimposed on the front ceiling wall portion 30A so that the boss 25 is inserted in the guide opening 35 and the stopper hooks 26 are inserted in the stopper openings 36.

A fixing screw 38 is screwed via a washer 37 in the boss 25 inserted in the guide opening 35. This couples the support frame 30 to the fixed blade holder 16. In the guide opening 35, a collar 39 made of a resin for protecting an inner circumferential edge of the guide opening 35 is fitted. It should be noted that the collar 39 is not an indispensable element and may be omitted.

As described above, the fixed blade holder 16 is coupled to the support frame 30 with the fixing screw 38 inserted in the guide opening 35, and the fixing screw 38 is guided movably in the orthogonal direction (fore-and-aft directions L1) along the guide opening 35. Therefore, the fixed blade holder 16 can move in the orthogonal direction (fore-and-aft directions L1) along the guide opening 35.

The fixing screw 38, the washer 37, and the collar 39 are inserted in the guide opening 35, and function as the coupling member 31 coupling the support frame 30 to the fixed blade holder 16.

Further, a wall portion 30d rises from the front ceiling wall portion 30A along the cutout portion so as to be opposed to the front panel 30c. Coil springs (biasing members) 40 are provided between the wall portion 30d and the leg portions 16c of the fixed blade holder 16. Each of the coil springs 40 biases the fixed blade holder 16 toward the front panel 30c side. That is, each of the coil springs 40 plays a role of biasing the fixed blade holder 16 to the front side at all times so as to bring the cutting edge 9a of the fixed blade 9 into press-contact with the cutting edge 8a of the movable blade 8, when the movable blade 8 is slid.

At this time, as illustrated in FIG. 8, the stopper hooks 26 come into contact with the stopper openings 36 to regulate the excess forward movement of the fixed blade holder 16. Therefore, the fixed blade 9 is designed so as not to come into contact with the front panel 30c of the support frame 30.

Further, as illustrated in FIGS. 9 and 11, the front ceiling wall portion 30A is provided with three convex portions 30e at intervals along the wall portion 30d. The convex portions 30e are formed in, for example, a ring shape, and position coil springs 41 described later.

Further, the fixed blade holder **16** can move in the orthogonal direction (fore-and-aft directions L1) as described above. The fixed blade holder **16** is coupled to the support frame **30** at one place of the fixing screw **38**, and hence, is swingable about the center axis of the fixing screw **38** in addition to the mere movement, as indicated by an arrow illustrated in FIG. **12**. Therefore, the fixed blade **9** held by the fixed blade holder **16** swings with a high degree of freedom in the blade width direction with the fixed screw **38** being a pivot.

As illustrated in FIG. **9**, the head support frame **15** supporting the thermal head **6** is provided below the holder support frame **17** thus configured. The head support frame **15** is attached to the holder support frame **17** so as to be capable of pivoting about a rotation pivot N.

The thermal head **6** is formed so as to extend in the width direction (right-and-left directions L3) of the recording sheet P, and a number of heat-generating elements (not shown) are arranged in the right-and-left directions L3 on the surface (lower surface) of the thermal head **6**. Further, the coil springs **41** biasing the thermal head **6** to the platen roller **5** side are provided between the back surface (upper surface) of the head support frame **15** and the front ceiling wall portion **30A** of the support frame **30**. Thus, when the detachable unit **11** is combined with the main unit **10**, the thermal head **6** is held in contact with the platen roller **5** with the recording sheet P sandwiched therebetween under a predetermined contacting pressure. Therefore, satisfactory printing can be performed with respect to the recording sheet P.

One end of each coil spring **41** is externally provided on the convex portion **30e** formed on the front ceiling wall portion **30A**, and the other end thereof is externally provided on a convex portion **15a** formed on the head support frame **15**. Thus, the coil springs **41** are provided between the head support frame **15** and the front ceiling wall portion **30A** while being positioned precisely.

Further, as illustrated in FIGS. **6** and **7**, the fixed blade holder cover **18** is attached to the holder support frame **17** so as to cover the back side, and the latch cover **19** is attached to the holder support frame **17** so as to cover the front side, as described above.

The fixed blade holder cover **18** is a cover in a C-shape, both the right and left sides of which are bent downward, and covers the back ceiling wall portion **30B** of the support frame **30** from above, and is attached so that side wall portions **18a** cover from outside of the side panels **30b** of the support frame **30**. Then, a shaft **45** is inserted so as to pass through the support frame **30** in the right-and-left directions L3 through the side wall portions **18a** of the fixed blade holder cover **18** and the side panels **30b** of the support frame **30**.

Both the ends of the shaft **45** respectively protrude outward in the right-and-left directions L3 further from the side wall portions **18a** of the fixed blade holder cover **18**.

The latch cover **19** is a cover in a C-shape, both the right and left sides of which are bent downward in the same way as in the fixed blade holder cover **18**, and covers the front ceiling wall portion **30A** of the support frame **30** from above and is provided so that side wall portions **19a** cover from outside of the side panels **30b** of the support frame **30**. The latch cover **19** is coupled to the support frame **30** via a shaft **46**, and can rotate about the shaft **46** in the fore-and-aft directions L1.

The shaft **46** is inserted so as to pass through the support frame **30** in the right-and-left directions L3 through the side panels **30b** of the support frame **30** and the side wall portions **19a** of the latch cover **19**, and both ends thereof protrude outward in the right-and-left directions L3 further from the side wall portions **19a** of the latch cover **19**. Cylindrical bushes **47** are fitted at both ends of the shaft **46**.

Each end of the shaft **46** and each of the bushes **47** function as an engagement pin **50** that is non-coaxial with respect to a platen shaft C of the platen roller **5** provided on the main unit **10** side and protrudes along a parallel axial line. That is, the latch cover **19** can rotate freely about the axial line of the engagement pin **50** in the fore-and-aft directions L1.

Further, a lock pin **51** protruding in the right-and-left directions L3 is formed integrally on each of the side wall portions **19a** of the latch cover **19**. The lock pin **51** is formed so as to be parallel to the engagement pin **50** at a position separated by a predetermined distance from the axial line of the engagement pin **50**, and rotates and moves so as to draw an arcuate path about the axial line of the engagement pin **50** along with the rotation of the latch cover **19**. That is, the lock pin **51** can perform relative movement in a virtual plane (virtual plane S illustrated in FIG. **6**, orthogonal to the right-and-left directions L3) orthogonal to the platen shaft C with respect to the engagement pin **50** along with the rotation of the latch cover **19**.

Further, coil springs (biasing members) **52** are attached between the latch cover **19** and the fixed blade holder cover **18**, and pull the latch cover **19** to the fixed blade holder cover **18** side. That is, the coil springs **52** bias the latch cover **19** so that the lock pin **51** rotates and moves toward the back side.

The latch cover **19** thus configured is further covered with the release cover **20**.

The release cover **20** is a C-shaped cover, both right and left sides of which are bent downward, and covers the latch cover **19** and the front panel **30c** of the support frame **30** from above, and is provided so that side wall portions **20a** cover the side wall portions **18a** of the fixed blade holder cover **18** from outside. At this time, the release cover **20** is coupled to the fixed blade holder cover **18** via the shaft **45** described above, and can rotate about the shaft **45**.

The cylindrical bushes **47** are fitted at both ends of the shaft **45** protruding outward in the right-and-left directions L3 from the side wall portions **20a** of the release cover **20**. Then, each end of the shaft **45** and each of the bushes **47** function as an auxiliary pin **53** protruding in directions parallel to the engagement pin **50**. Thus, the release cover **20** can rotate about the axial line of the auxiliary pin **53**.

The side wall portion **20a** of the release cover **20** is provided with a curved recess **20b** so that a part of a front edge is curved smoothly toward the back and a hook portion **20c** protrudes forward due to the curved recess **20b**. Then, the latch cover **19** and the release cover **20** are combined so that the lock pin **51** is fitted in the curved recess **20b**.

In particular, the latch cover **19** is pulled to the fixed blade holder cover **18** side by the coil springs **52** at all times. Therefore, the lock pin **51** is fitted in the curved recess **20b** reliably, and the lock pin **51** presses the hook portion **20c** downward. Thus, the release cover **20** receives a force from the lock pin **51**, and is biased so as to rotate to the front side covering the front panel **30c** of the support frame **30** at all times.

The detachable unit **11** thus configured is attached to the inner surface of the open/close door **3** via the release cover **20**. Therefore, when the open/close cover **3** is opened while the detachable unit **11** is combined with the main unit **10**, the release cover **20** rotates to the back side separated from the front panel **30c** of the support frame **30** about the axial line of the auxiliary pin **53** accordingly.

Then, the hook portion **20c** formed in the side wall portion **20a** of the release cover **20** pushes up the lock pin **51** to rotate and move the lock pin **51** to a front side that is an opposite direction to the biasing direction by the coil spring **52**.

(Main Unit)

11

Next, the main unit 10 is described.

As illustrated in FIGS. 3 to 5 and 14, the main unit 10 mainly includes the movable blade 8, the platen roller 5, and a main frame 60 supporting the movable blade 8 and the platen roller 5. FIG. 14 is a perspective view of the main unit 10.

The main frame 60 is formed of metal, a resin, or the like in a box shape, and an upper surface 60a functions as a passage plane for the recording sheet P. The recording sheet P is fed while a surface opposite to a printed surface is faced to the upper surface 60a that is the passage plane.

Further, a front cover 61a and side covers 61b are detachably attached to a front wall portion 60b and side wall portions 60c of the main frame 60. Each side wall portion 60c is formed at a position dented inside of the main frame 60, and an accommodating space E in which each component can be accommodated is ensured within the side wall portions 60c and the side covers 61b.

A pair of opposed walls 62, which protrude above the upper surface 60a and are opposed to each other in the right-and-left directions L3 with the upper surface 60a interposed therebetween, are provided in upper portions of the side wall portions 60c.

The pair of opposed walls 62 are each provided with a plurality of recesses for combining the detachable unit 11 with the main unit 10 separably. That is, a first recess 65, a second recess 66, and a third recess 67 are respectively formed from the front side to the back side in this order.

The main unit 10 is sized so that the side wall portions 20a of the release cover 20 are positioned inside the opposed walls 62 when the detachable unit 11 is combined with the main unit 10.

The first recess 65 allows the engagement pin 50 to be fitted therein detachably to place the thermal head 6 and the platen roller 5 so that the thermal head 6 and the platen roller 5 are opposed to each other in contact state, and is formed so as to be opened diagonally from the upper edge to the front side of the opposed wall 62.

The second recess 66 allows the lock pin 51 to be fitted therein detachably after the engagement pin 50 is fitted in the first recess 65, and is formed so as to be opened diagonally from the midway of the opening of the first recess 65 to the back side.

In particular, the latch cover 19 receives a force for rotating the latch cover 19 to the back side by the coil springs 52. Therefore, the lock pin 51 is fitted in the second recess 66 naturally. When being fitted in the second recess 66, the lock pin 51 is simultaneously fitted in the curved recess 20b formed in the side wall portion 19a of the latch cover 19 and presses the hook portion 20c of the latch cover 19 downward. Thus, after the detachable unit 11 is mounted, the release cover 20 is biased so as to rotate to the front side covering the front panel 30c of the support frame 30.

Further, as illustrated in FIGS. 3 and 15, when the engagement pin 50 and the lock pin 51 are fitted in the first recess 65 and the second recess 66, respectively, a part of an inner circumferential edge of the second recess 66 prevents the lock pin 51 from moving in the opening direction of the first recess 65. Thus, as long as the lock pin 51 is not detached from the second recess 66, the engagement pin 50 cannot be detached from the first recess 65.

FIG. 15 is a view illustrating a state in which the main unit 10 and the detachable unit 11 are combined when viewed from a side.

On the other hand, when the release cover 20 is rotated to the back side about the axial line of the auxiliary pin 53, the lock pin 51 is pushed up by the hook portion 20c and can be

12

rotated in a direction opposite to the biasing direction by the coil springs 52, as illustrated in FIGS. 16 and 17. This enables the lock pin 51 to be detached from the second recess 66. Thus, when the lock pin 51 is detached, the engagement pin 50 can be detached from the first recess 65.

FIG. 16 is a view illustrating a state in which the release cover 20 is rotated to the back side from the state illustrated in FIG. 15, and the lock pin 51 is pushed up by the hook portion 20c. FIG. 17 is a view illustrating a state in which the lock pin 51 is further pushed up from the state illustrated in FIG. 16.

More specifically, the engagement pin 50 according to this embodiment cannot be detached from the first recess 65 when the lock pin 51 is fitted in the second recess 66, and can be detached from the first recess 65 after the lock pin 51 is detached from the second recess 66. Thus, only when the engagement pin 50 is detached from the first recess 65 after the lock pin 51 is detached from the second recess 66 first, the detachable unit 11 can be separated from the main unit 10.

Further, the third recess 67 allows the auxiliary pin 53 to be fitted therein detachably at a timing when the engagement pin 50 is fitted in the first recess 65, and is formed so as to be opened in the same direction as the opening direction of the first recess 65.

Thus, even if an external force of rotating the lock pin 51 about the axial line of the engagement pin 50 to detach the lock pin 51 from the second recess 66 acts on the entire detachable unit 11 when the detachable unit 11 is mounted on the main unit 10, the auxiliary pin 53 comes into contact with a part of the inner circumferential edge of the third recess 67 to regulate the movement of the detachable unit 11.

Accordingly, the lock pin 51 is prevented from being detached from the second recess 66 unintentionally, and the reliability during mounting of the detachable unit 11 can be enhanced, and the looseness and the like of the detachable unit 11 can be suppressed easily.

As illustrated in FIG. 9, the platen roller 5 has a configuration in which a roller 5b made of an elastic material such as rubber is provided externally on an axial body 5a such as a shaft extending in the width direction of the recording sheet P. As illustrated in FIGS. 3 and 4, both ends of the axial body 5a are axially supported by the side wall portions 60c of the main frame 60 via bearing members 70. At the end on one side of the axial body 5a, a driven gear to be meshed with a gear train mechanism for a platen (not shown) is fixed. Then, due to the drive of a platen motor (not shown) provided in the main frame 60, a rotational force is transmitted to the driven gear via the gear train mechanism for a platen, which rotates the platen roller 5.

As illustrated in FIGS. 3, 4, and 9, the platen roller 5 is placed so that a part thereof is exposed from the upper surface 60a of the main frame 60. The platen roller 5 plays a role of feeding the recording sheet P to the front side that is a downstream side while sandwiching the recording sheet P together with the thermal head 6 and sending out the recording sheet P between the fixed blade 9 and the movable blade 8, when the detachable unit 11 is mounted on the main unit 10.

The movable blade 8 has a function as a cutter for cutting the recording sheet P in cooperation with the fixed blade 9, and is placed at a position opposed to the fixed blade 9 when the detachable unit 11 is mounted on the main unit 10, as illustrated in FIGS. 1 and 2. As illustrated in FIG. 10, the movable blade 8 is a plate-shaped blade in a substantially V-shape when viewed from above, which is formed so that the length from the root to the cutting edge 8a becomes shorter gradually from both ends to the center. When the movable blade 8 is slid toward the fixed blade 9, the movable blade 8 rides on the fixed blade 9, as illustrated in FIGS. 9 and 18, and

13

cuts the recording sheet P while sandwiching it between the movable blade 8 and the fixed blade 9.

FIG. 18 illustrates a state in which the movable blade 8 is slid from the state illustrated in FIG. 10.

Because the movable blade 8 is formed in a substantially V-shape when viewed from above, the movable blade 8 comes into contact with the fixed blade 9 at two right and left points (points M illustrated in FIG. 18). Further, the movable blade 8 according to this embodiment is curved smoothly in the width direction so that both ends are warped from the center portion so as to come into contact with the fixed blade 9 reliably at the two right and left points. Thus, the recording sheet P can be cut from both right and left sides to the center along with the slide of the movable blade 8.

As illustrated in FIGS. 5 and 9, the movable blade 8 thus formed is placed inside of the front wall portion 60b of the main frame 60 with the cutting edge 8a directed upward, and fixed to a movable blade holder 80. The movable blade holder 80 is a plate-shaped member made of a resin or the like and is guided movably in the up-and-down directions L2 by guide means (not shown). This enables the movable blade 8 to be slid in the up-and-down directions L2 substantially orthogonal to the sheet surface of the recording sheet P.

As illustrated in FIG. 19, a rack (reciprocating mechanism) 81 is integrally formed in a lower end portion of the movable blade holder 80. FIG. 19 illustrates a part of an inner structure of the main frame 60.

As illustrated in FIGS. 3 and 4, the rack 81 plays a role of reciprocating the movable blade holder 80 linearly in the up-and-down directions L2 along with the rotation of a drive gear 82 coupled to a movable blade motor (see FIG. 20) 95. Further, as illustrated in FIG. 19, a coil spring (biasing member) 83 is attached between the movable blade holder 80 with the rack 81 attached thereto and the bottom wall portion of the main frame 60, and the coil spring 83 pulls the movable blade holder 80 in a downward direction of separating the movable blade 8 from the fixed blade 9. Thus, a downward force is applied to the movable blade holder 80 at all times.

As illustrated in FIGS. 3, 4, and 19, a gear train mechanism for a movable blade (gear train mechanism) 90 including a first gear 91, a second gear 92, and a third gear 93 is provided between the rack 81 and the drive gear 82.

The gear train mechanism for a movable blade 90 couples the drive gear 82 to the rack 81 to transmit a rotational force of the drive gear 82 to the rack 81 when the detachable unit 11 is combined with the main unit 10 as illustrated in FIG. 3, and disconnects the drive gear 82 from the rack 81 when the detachable unit 11 is separated from the main unit 10 as illustrated in FIG. 4.

Hereinafter, the configuration is described in detail.

The movable blade motor (see FIG. 20) 95 is placed in the main frame 60, and a drive shaft protrudes to the side wall portion 60c. Then, the drive gear 82 is fixed to the drive shaft. The third gear 93 is axially supported on the side wall portion 60c while being meshed with the rack 81. Further, the second gear 92 is axially supported on the side wall portion 60c similarly while being meshed with the third gear 93.

As illustrated in FIGS. 20 and 21, a swinging plate 96 that swings forward/backward with respect to the drive shaft is placed between the drive gear 82 and the side wall portion 60c.

FIG. 20 is a side view of the main unit 10 illustrated in FIG. 4, illustrating a state in which the first gear 91 is removed. FIG. 21 is a side view of the main unit 10 illustrated in FIG. 3, illustrating a state in which the first gear 91 is removed.

The swinging plate 96 is formed in a substantially semi-circular shape when viewed from above, and a part on an

14

upper portion side thereof forms a hook-shaped locking piece 96a protruding outward. Further, at the swinging plate 96, a shaft core 96b axially supporting the first gear 91 in the vicinity of the root of the locking piece 96a rises so as to be adjacent to the drive gear 82, and a fixing pin 96c for fixing one end side of a coil spring (biasing member) 98 described later rises on a lower portion side.

The first gear 91 is attached to the shaft core 96b of the swinging plate 96 while being meshed with the drive gear 82. Therefore, the first gear 91 rotates about the drive shaft along with the swing of the swinging plate 96, and moves close to the second gear 92 to be meshed therewith as illustrated in FIGS. 3 and 21 or moves away from the second gear 92 to cancel the mesh as illustrated in FIGS. 4 and 20.

Herein, a fixing pin 97 rises on the side wall portion 60c in the vicinity of the second gear 92, and the coil spring 98 is attached between the fixing pin 97 and the fixing pin 96c of the swinging plate 96. The coil spring 98 biases the swinging plate 96 so that the swinging plate 96 rotates to the back side at which the first gear 91 is moved away from the second gear 92 as illustrated in FIG. 20. Thus, as long as an external force is not given to the swinging plate 96, the first gear 91 and the second gear 92 are disconnected from each other.

The swinging plate 96 is provided with a protective cover 99 in a crescent shape when viewed from above, which protects the drive gear 82.

A push button 100 is in contact with the locking piece 96a of the swinging plate 96. The push button 100 is attached to the upper surface 60a of the main frame 60 so as to move up/down, and as illustrated in FIG. 14, an upper portion is exposed from the upper surface 60a. Further, as illustrated in FIG. 20, a lower portion of the push button 100 is formed in a smooth arcuate shape and rides on the locking piece 96a. Thus, the push button 100 is pushed upward by the locking piece 96a so that the upper portion thereof sticks out of the upper surface 60a.

With such a configuration, in the case where the detachable unit 11 is separated from the main unit 10, as illustrated in FIGS. 4 and 20, the swinging plate 96 is rotated to the back side due to the force of the coil spring 98 to disconnect the first gear 91 from the second gear 92. Consequently, the rack 81, the third gear 93, and the second gear 92 are not engaged with the drive gear 82, i.e., are in a free state. Thus, as illustrated in FIG. 19, the movable blade holder 80 pulled downward by the coil spring 83 cannot be moved upward, and the movable blade 8 can be placed in a standby position of being moved away from the fixed blade 9.

On the other hand, in the case where the detachable unit 11 is mounted on the main unit 10, as illustrated in FIGS. 3 and 21, the push button 100 is pressed by a push protrusion 101 (see FIG. 20) provided at the detachable unit 11, to thereby move downward. This enables a downward force to be applied to the locking piece 96a and enables the swinging plate 96 to rotate to the front side due to the force against the coil spring 98, which allows the first gear 91 to be meshed with the second gear 92. Consequently, the drive gear 82 is coupled to the rack 81, and the rotational force of the drive gear 82 can be transmitted to the rack 81.

Next, the operation of the thermal printer 1 configured as described above is described.

First, as illustrated in FIG. 2, the paper roll R is inserted in the casing 2 through the insertion port 2a while the open/close door 3 is opened. At this time, the recording sheet P is previously pulled outside the casing 2 by some length. Then, while the pulled-out recording sheet P is pulled outside the casing 2, the open/close door 3 is closed and locked with a lock mechanism. Simultaneously with this, the detachable unit 11 is

15

mounted on the main unit 10, and thus, both the units 10, 11 are combined with each other.

Consequently, as illustrated in FIG. 1, the recording sheet P is sandwiched between the platen roller 5 and the thermal head 6, and is pulled outside the casing 2 from the discharge port 2c.

Incidentally, as illustrated in FIGS. 4 and 21, while the open/close door 3 is opened, the swinging plate 96 is pulled by the coil spring 98, and hence, the first gear 91 and the second gear 92 are disconnected from each other. Therefore, the rack 81, the third gear 93, and the second gear 92 are not engaged with the drive gear 82, i.e., are in a free state. Thus, the movable blade holder 80 is pulled downward by the coil spring 83 as illustrated in FIG. 19. This places the movable blade 8 at a standby position of being moved away from the fixed blade 9. Further, as illustrated in FIG. 14, the push button 100 is in a state of sticking out of the upper surface 60a of the main frame 60.

In particular, because the rack 81 and the drive gear 82 are disconnected from each other, even if the movable blade motor 95 is driven by mistake under a state before closing the open/close door 3, the rack 81 does not move linearly to slide the movable blade 8. Thus, due to an interlock structure regulating the slide of the movable blade 8, the movable blade 8 is allowed to be placed at a standby position continuously, which can ensure high safety.

Subsequently, when the open/close door 3 starts being closed, the detachable unit 11 gradually approaches the main unit 10 while drawing an arcuate path with respect to the hinge portion 7, and finally moves close to the main unit 10 in the sliding direction (up-and-down directions L2) of the movable blade 8. Then, the engagement pin 50 and the auxiliary pin 53 of the detachable unit 11 first start entering the first recess 65 and the third recess 67, and the lock pin 51 slips off while being in contact with an inclined portion that is an inlet of the first recess 65.

At this time, the reaction force against a force pressing down the open/close door 3 functions to push up the lock pin 51 via the inclined portion. Then, the reaction force is transmitted to the latch cover 19 via the lock pin 51, and hence, the latch cover 19 rotates to the front side about the axial line of the engagement pin 50. That is, the latch cover 19 moves downward along with the closing operation of the open/close door 3 while rotating to the front side about the axial line of the engagement pin 50.

Thus, the engagement pin 50 and the auxiliary pin 53 gradually enter an innermost part of the first recess 65 and an innermost part of the third recess 67 at the same timing, and, as illustrated in FIGS. 3 and 15, are fitted in the first recess 65 and the third recess 67 completely at a time when the open/close door 3 is closed completely. Further, at this time, the lock pin 51 reaches the inlet of the second recess 66. In this case, the latch cover 19 is pulled to the fixed blade holder cover 18 side by the coil spring 52, and hence, the latch cover 19 is to be rotated to the back side. Therefore, the lock pin 51 having reached the inlet of the second recess 66 can be immediately pulled in and fitted in the second recess 66.

Consequently, simultaneously with the closing of the open/close door 3, the detachable unit 11 can be combined with the main unit 10 while the detachable unit 11 is mounted on the main unit 10. Further, the engagement pin 50 can be set in the first recess 65 so as not to be detached therefrom.

Further, as illustrated in FIGS. 1 and 19, at this time, the thermal head 6 and the platen roller 5 can be arranged so as to be opposed to each other with the recording sheet P sandwiched therebetween. In this case, because the head support frame 15 is biased to the platen roller 5 side by the coil springs

16

41, the thermal head 6 can be brought into contact with the platen roller 5 under a predetermined press-contact force. Further, the cutting edge 9a of the fixed blade 9 and the cutting edge 8a of the movable blade 8 can be opposed to each other with the recording sheet P sandwiched therebetween.

Incidentally, when the detachable unit 11 is mounted on the main unit 10, as illustrated in FIGS. 3 and 21, the push button 100 sticking out of the upper surface 60a of the main frame 60 is pressed by the push protrusion 101 of the detachable unit 11 to move downward. Then, the push button 100 presses down the locking piece 96a, and hence, rotates the swinging plate 96 to the front side with a force against the coil spring 98. Thus, the first gear 91 rotates so as to move close to the second gear 92 together with the swinging plate 96, to thereby be meshed with the second gear 92 finally. This mesh is maintained as long as the detachable unit 11 is not separated from the main unit 10.

Accordingly, all the first gear 91, the second gear 92, and the third gear 93 are meshed with each other, and hence, the gear train mechanism for a movable blade 90 couples the drive gear 82 with the rack 81. This enables the rotational force of the drive gear 82 to be transmitted to the rack 81.

Next, the case of performing printing on the recording sheet P is described.

In this case, first, the platen motor is driven to rotate the platen roller 5. This allows the recording sheet P sandwiched between the platen roller 5 and the thermal head 6 to be fed forward, and simultaneously, the paper roll R mounted on the mounting board 2b rotates.

The thermal head 6 is operated at the same time. This causes a number of heat-generating elements to generate heat appropriately. As a result, various characters and graphics can be printed clearly on the fed recording sheet P. After that, the recording sheet P further fed by the platen roller 5 passes through between the fixed blade 9 and the movable blade 8.

Incidentally, even if an external force is applied from the recording sheet P, the thermal head 6, or the like to the platen roller 5 while printing is performed with the detachable unit 11 being combined with the main unit 10, the external force is unlikely to be transmitted to the engagement pin 50 and the lock pin 51 that are not coaxial to the platen shaft C. This can prevent the engagement pin 50 and the lock pin 51 from being detached from the first recess 65 and the second recess 66 due to the influence of the external force. Thus, the detachable unit 11 can be combined with the main unit 10 securely with high reliability. Therefore, the thermal head 6 and the platen roller 5 can be combined stably, and stable printing can be performed.

During mounting of the detachable unit 11, the lock pin 51 is unlikely to move in a direction in which the lock pin 51 is detached from the second recess 66 by the bias of the coil spring 52. Therefore, it is possible to prevent the lock pin 51 from being detached from the second recess 66 unintentionally, and to render the combination of the main unit 10 and the detachable unit 11 reliable.

In addition to the engagement pin 50 and the lock pin 51, the auxiliary pin 53 is fitted in the third recess 67. Therefore, the detachable unit 11 can be fixed at two places in the fore-and-aft directions L1 with respect to the main unit 10, and the detachable unit 11 and the main unit 10 can be combined more strongly. Therefore, even if some external force is applied to the detachable unit 11, looseness and the like are unlikely to occur. In this respect, stable printing can be performed.

Next, the case of cutting the recording sheet P after finishing printing is described.

In this case, the drive gear **82** is rotated by driving the movable blade motor **95**. Then, as illustrated in FIG. **3**, the rotational force is transmitted to the third gear **93** via the first gear **91** and the second gear **92** to rotate the third gear **93**. This enables the rack **81** meshed with the third gear **93** to move linearly. Thus, the movable blade **8** can be slid upward to be directed to the fixed blade **9** so that the state illustrated in FIGS. **10** and **19** is shifted to the state illustrated in FIGS. **9** and **18** via the movable blade holder **80** integrated with the rack **81**.

Then, as illustrated in FIG. **18**, the slid movable blade **8** overlaps the fixed blade **9** as if the movable blade **8** rides on the fixed blade **9**, and cuts the recording sheet P while sandwiching the recording sheet together with the fixed blade **9**.

At this time, the movable blade **8** is formed in a substantially V-shape when viewed from above, and hence, comes into contact with the fixed blade **9** at two right and left points. Thus, the recording sheet P can be cut from both right and left sides to the center of the recording sheet along with the slide of the movable blade **8**, and the recording sheet P can be cut satisfactorily without any bias. As a result, the cut piece of the recording sheet P can be used as a sales check, a ticket, or the like.

Incidentally, when the movable blade **8** rides on the fixed blade **9**, the movable blade **8** tries to push the fixed blade **9** to the back side. However, as illustrated in FIG. **9**, the fixed blade holder **16** supporting the fixed blade **9** is biased to the front side by the coil springs **40**. Thus, the cutting edge **9a** of the fixed blade **9** can be brought into press-contact with the cutting edge **8a** of the movable blade **8** under an appropriate contacting pressure. Thus, a gap is unlikely to be formed between the cutting edge **9a** of the fixed blade **9** and the cutting edge **8a** of the movable blade **8**, and thus, the recording sheet P can be cut with satisfactory sharpness.

Further, unlike the conventional example in which a fixed blade is held so that a cutting edge thereof swings, the fixed blade **9** according to this embodiment is held by the fixed blade holder **16** that is supported so as to be movable in the orthogonal direction (fore-and-aft directions **L1**) by the holder support frame **17**. Therefore, as illustrated in FIGS. **9** and **22**, when the movable blade **8** starts riding on the fixed blade **9** gradually along with the slide, the fixed blade holder **16** moves in the orthogonal direction (fore-and-aft directions **L1**), i.e., moves to the back side accordingly. Thus, the inclined state of the fixed blade **9** can be maintained constantly with respect to the movable blade **8**, that is, an angle formed by the cutting edge **9a** of the fixed blade **9** with respect to the cutting edge **8a** of the movable blade **8** can be continued to be kept at an optimum cutting angle θ , irrespective of the slide condition of the movable blade **8**.

As a result, the recording sheet P can be cut while the optimum cutting angle θ is kept at all times from the beginning of cutting to the end of cutting. There is a low risk that cutting defects such as uncut portions occur in the recording sheet P, which enables satisfactory cutting to be performed stably.

FIG. **22** is a schematic view illustrating how the movements of the movable blade **8** and the fixed blade **9** held by the fixed blade holder **16** change along with the proceeding of the slide of the movable blade **8**.

Further, the fixed blade holder **16** according to this embodiment is capable of not only moving in the orthogonal direction (fore-and-aft directions **L1**), but also swinging about the fixing screw **38**, as illustrated in FIG. **12**. Therefore, the fixed blade **9** held by the fixed blade holder **16** can swing in the blade width direction with a high degree of freedom. Therefore, the fixed blade **9** is allowed to follow the movement of

the movable blade **8** by swinging the fixed blade **9** freely in the blade width direction in accordance with the behavior of the movable blade **8** from the beginning to the end of cutting. Consequently, the press-contact forces at the two right and left contact points can be easily well-balanced equally.

Thus, the recording sheet P can be cut from both the right and left sides thereof more reliably, and cutting defects can be rendered further unlikely to occur.

In particular, in the case of the cutter mechanism **4** of the type in which the movable blade **8** and the fixed blade **9** are separable as in this embodiment, it is considered that it is difficult to set the fixed blade **9** and the movable blade **8** at predetermined positions every time with good positional accuracy when the detachable unit **11** is combined with the main unit **10**. Thus, the balance of the press-contact between the movable blade **8** and the fixed blade **9** is likely to be degraded, and in some cases, inconvenience such as the degradation in sharpness of one of the blades may be caused.

However, in the case of this embodiment, even if a shift is caused at set positions of the fixed blade **9** and the movable blade **8**, the fixed blade **9** swings freely in the blade width direction with respect to the fixing screw **38** as described above, and hence, the press-contact forces at the two right and left contact points can be well-balanced equally. Thus, the risk that the above-mentioned inconvenience may occur can be decreased.

Next, the case where paper jam or the like occurs during printing, and the movable blade **8** is stopped halfway through sliding is described.

In this case, the movable blade **8** rides on (covers) the fixed blade **9**. In this embodiment, the detachable unit **11** can be moved close to and away from the main unit **10** in the sliding direction (up-and-down directions **L2**) of the movable blade **8**. Thus, even if the movable blade **8** is stopped halfway through sliding, the detachable unit **11** can be separated from the main unit **10**, and the fixed blade **9** can be pulled out so as to be slid on the movable blade **8**.

This point is described in detail.

First, after the lock mechanism is cancelled, the open/close door **3** is opened so as to be rotated to the back side about the hinge portion **7**. Then, as illustrated in FIGS. **16** and **17**, the release cover **20** attached to the inner surface of the open/close door **3** starts rotating to the back side about the axial line of the auxiliary pin **53** along with the opening operation of the open/close door **3**. Therefore, the release cover **20** pushes up the lock pin **51** via the hook portion **20c**.

Then, this force is transmitted to the latch cover **19** via the lock pin **51**, and hence, the latch cover **19** rotates to the front side due to the force against the coil spring **52** about the axial line of the engagement pin **50**. Thus, the lock pin **51** is detached from the second recess **66** along with the rotation of the latch cover **19**. Consequently, the engagement pin **50** and the auxiliary pin **53** can move in the opening direction of the first recess **65** and the third recess **67**.

After the engagement pin **50** and the auxiliary pin **53** move along the first recess **65** and the third recess **67** at the same timing along with further opening operation of the open/close door **3**, the engagement pin **50** and the auxiliary pin **53** are detached from the first recess **65** and the third recess **67** completely. Thus, the detachable unit **11** can be disconnected from the main unit **10** and separated from each other. Then, the detachable unit **11** can be separated largely from the main unit **10** by further opening the open/close door **3**.

In particular, when the detachable unit **11** is separated, the detachable unit **11** moves as if the detachable unit **11** draws an arcuate path with respect to the hinge portion **7** together with the open/close door **3**. Therefore, in the initial stage of sepa-

ration, the detachable unit **11** moves in the sliding direction (up-and-down directions **L2**) of the movable blade **8**. Thus, even when the movable blade **8** is stopped halfway through sliding and rides on the fixed blade **9** as illustrated in FIG. **9**, the fixed blade **9** can be pulled out so as to be slid on the movable blade **8** as described above.

Accordingly, even in the case where the movable blade **8** is stopped halfway through sliding, the movable blade **8** and the fixed blade **9** can be separated from each other easily unlike the conventional example. Then, after opening the open/close door **3** largely, operations for recovery from various inconveniences such as paper jam can be performed immediately.

In particular, when the detachable unit **11** is separated from the main unit **10**, the gear train mechanism for a movable blade **90** mechanically disconnects the drive gear **82** and the rack **81** from each other along with the separation. That is, the press-down of the push button **100** is released when the detachable unit **11** is separated. Therefore, as illustrated in FIG. **20**, the swinging plate **96** is pulled by the coil spring **98** to rotate to the back side. Therefore, as illustrated in FIG. **4**, the first gear **91** is moved away from the second gear **92**, and the mesh therebetween is cancelled. As a result, the drive gear **82** is disconnected from the rack **81**.

Thus, the rack **81** is placed in a free state to be not engaged with the movable blade motor **95**. Then, as illustrated in FIG. **19**, the movable blade holder **80** formed integrally with the rack **81** is pulled by the coil spring **83** to move downward. This can automatically restore the movable blade **8** at a standby position (initial position) before the slide, which can prevent the cutting edge **8a** of the movable blade **8** from remaining sticking out at a time of separation of the detachable unit **11**.

Accordingly, the operations for recovery from various inconveniences can be performed without taking special care to the movable blade **8**, and thus, excellent safety is ensured. Further, as described above, the rack **81** is disconnected from the drive gear **82**, and hence, the movable blade **8** does not move even if the movable blade motor **95** is driven by mistake (interlock mechanism). In this respect, high safety can be ensured.

As described above, the thermal printer **1** according to this embodiment can exhibit the following functional effects.

First, with only simple operations of fitting/detachment of the engagement pin **50** with respect to the first recess **65** and fitting/detachment of the lock pin **51** with respect to the second recess **66** due to the relative movement thereof to the engagement pin **50**, the attachment/detachment operation of the detachable unit **11** can be performed smoothly. Thus, the main unit **10** and the detachable unit **11** can be combined quickly, or the combination thereof can be cancelled by separating the main unit **10** and the detachable unit **11** from each other quickly.

Further, unlike the case of using a conventional lock lever protruding largely outward, the detachable unit **11** is provided with the engagement pin **50**, the lock pin **51**, and the auxiliary pin **53** protruding slightly in a direction parallel to the platen shaft **C**. Thus, fingertips are unlikely to interfere with the attachment/detachment operation of the detachable unit **11**, and the safety is more excellent compared with that of the conventional example.

Further, the engagement pin **50**, the lock pin **51**, and the auxiliary pin **53** are respectively fitted in the first recess **65**, the second recess **66**, and the third recess **67** formed in each of the opposed walls **62** of the main unit **10**. Therefore, unlike the case of using a conventional lock lever, the size of the horizontal width of the detachable unit **11** (horizontal width

along the platen shaft **C**) can be contained in an interval of the opposed walls **62**. Thus, the entire thermal printer **1** can be miniaturized.

Further, even in the case where the movable blade **8** is stopped halfway through sliding, the main unit **10** and the detachable unit **11** can be separated from each other while the movable blade **8** is automatically restored to the original position, and in addition, the slide of the movable blade **8** that has been automatically restored can be regulated. Thus, excellent safety is ensured.

Further, due to the presence of the cutter mechanism **4** capable of maintaining the angle formed by the cutting edge **9a** of the fixed blade **9** with respect to the cutting edge **8a** of the movable blade **8** at the optimum cutting angle θ at all times and capable of allowing the fixed blade **9** to swing freely in the blade width direction to follow the movement of the movable blade **8**, there is a low risk that cutting defects occur, and the recording sheet **P** can be cut satisfactorily. Consequently, the thermal printer **1** with enhanced reliability of cutting performance can be obtained. Further, the quality of the recording sheet **P** after being cut can be enhanced.

The technical range of the present invention is not limited to the above-mentioned embodiment, and can be modified variously within the range not exceeding the spirit of the present invention.

For example, in the above-mentioned embodiment, although the thermal printer **1** is exemplified as an example of a printer, the printer is not limited to the thermal printer. For example, the printer may be an inkjet printer that performs printing on the recording sheet **P** using ink droplets, with a recording head serving as an inkjet head.

Further, in the above-mentioned embodiment, the thermal printer **1** is of a drop-in type in which the paper roll **R** is merely inserted to be placed on the mounting board **2b**. However, the thermal printer of an axial support type may be used instead, in which an axial support mechanism axially supporting (rotatably supporting) the paper roll **R** is provided in the casing **2**.

The casing **2** and the open/close door **3** are not indispensable components, and thus, may not be provided. That is, even only with the main unit **10** and the detachable unit **11**, the printer functions sufficiently.

Further, in the above-mentioned embodiment, the platen roller **5** and the movable blade **8** are provided on the main unit **10** side, and the thermal head **6** and the fixed blade **9** are provided on the detachable unit **11** side. However, the thermal head **6** may be provided on the main unit **10** side and the platen roller **5** may be provided on the detachable unit **11** side.

It should be noted that, by providing the thermal head **6** and the fixed blade **9** whose configurations are simplified easily on the detachable unit **11** side, the detachable unit **11** can be miniaturized and reduced in weight, which is suitable for attachment/detachment operability.

Further, in the above-mentioned embodiment, the latch cover **19** is provided with the lock pin **51**, and the lock pin **51** is allowed to rotate and move relative to the engagement pin **50** by rotating the latch cover **19**. However, the present invention is not limited to this case. For example, the lock pin **51** may be moved relative to the engagement pin **50** by sliding the lock pin **51** linearly. Even in this case, similar functional effects can be exhibited.

With a simple configuration in which the latch cover **19** is merely rotated as in the above-mentioned embodiment, the lock pin **51** can be moved relative to the engagement pin **50**. Thus, the configuration can be simplified and the parts count can be reduced.

21

Further, in the above-mentioned embodiment, when the detachable unit 11 is mounted on the main unit 10, the detachable unit 11 presses down the push button 100 to rotate the swinging plate 96, and the first gear 91 is meshed with the second gear 92. However, the pushbutton 100 is not indispensable, and a protrusion member for rotating the swinging plate 96 may be provided directly on the detachable unit 11 side.

Further, in the above-mentioned embodiment, the rotational movement of the drive gear 82 is converted into the linear movement using the rack 81, and the movable blade holder 80 is reciprocated linearly. However, the reciprocating mechanism may be designed freely without being limited to the rack 81, as long as the movable blade holder 80 can be reciprocated linearly along with the rotation of the drive gear 82.

For example, such a reciprocating mechanism may be configured by adopting a rotation cam that rotates along with the rotation of the drive gear 82 and a generally well-known mechanism that allows the rotation of the rotation cam to reciprocate the movable blade holder 80 linearly.

Further, in the above-mentioned embodiment, by rotating the swinging plate 96 that axially supports the first gear 91, the rack 81 and the drive gear 82 are coupled to or disconnected from each other. However, the present invention is not limited to such a configuration.

The gear train mechanism for a movable blade 90 may be designed freely as long as the drive gear 82 and the rack 81 are coupled together when the detachable unit 11 is combined with the main unit 10, and the drive gear 82 is disconnected from the rack 81 when the detachable unit 11 is separated from the main unit 10.

For example, as illustrated in FIG. 23, a gear train mechanism for a movable blade 110 (gear train mechanism) may be configured as follows: the gear train mechanism for a movable blade 110 includes an input gear 111 to be coupled to the drive gear 82 side and an output gear 112 to be coupled to the rack 81 side, and the input gear 111 is slid to be coupled to the output gear 112 by mounting of the detachable unit 11.

The above-mentioned case is described in detail.

The input gear 111 and the output gear 112 are axially supported by a common shaft core 113 while respective inner gears 111a, 112a are directed to the partner sides. In this case, the input gear 111 is slidable along the shaft core 113. Further, the shaft core 113 is externally provided with a coil spring 114 so that the coil spring 114 is interposed between the input gear 111 and the output gear 112 and biases both the gears 111, 112 so as to move the same away from each other. The input gear 111 is slid to the output gear 112 side by a link button 115 that is moved by mounting of the detachable unit 11, and allows the inner gear 111a to be meshed with the inner gear 112a of the output gear 112.

Even with such a configuration, the drive gear 82 and the rack 81 can be coupled together when the detachable unit 11 is combined with the main unit 10, and the drive gear 82 and the rack 81 can be disconnected from each other when the detachable unit 11 is separated from the main unit 10. Thus, similar functional effects can be exhibited.

Further, as another configuration, as illustrated in FIG. 24, the following may be adopted: a gear train mechanism for a movable blade (gear train mechanism) 120 includes an input gear 121 to be coupled to the drive gear 82 side, an output gear 122 to be coupled to the rack 81 side, and an intermediate gear 123 provided between the input gear 121 and the output gear 122, and the intermediate gear 123 is slid by mounting of the detachable unit 11 to couple the input gear 121 to the output gear 122.

22

The above-mentioned case is described in detail.

The input gear 121, the output gear 122, and the intermediate gear 123 are formed as bevel gears, and a shaft core 125 for the intermediate gear 123 is provided so as to be positioned between shaft cores 124 that axially support the input gear 121 and the output gear 122, respectively. In this case, the intermediate gear 123 is slidable along the shaft core 125. Further, the intermediate gear 123 is biased by a coil spring 126 so as to be moved away from the input gear 121 and the output gear 122. The intermediate gear 123 is slid against the coil spring 126 by a link button 127 moved by mounting of the detachable unit 11, and is meshed with both the input gear 121 and the output gear 122.

Even with such a configuration, the drive gear 82 and the rack 81 can be coupled to each other when the detachable unit 11 is combined with the main unit 10, and the drive gear 82 can be disconnected from the rack 81 when the detachable unit 11 is separated from the main unit 10. Thus, similar functional effects can be exhibited.

What is claimed is:

1. A printer with a cutter for cutting a recording sheet after printing is performed on the recording sheet, the printer comprising:

a main unit having a main frame supporting one of a recording head and a platen roller, a movable blade mounted to undergo sliding movement, and a movable blade motor for driving the movable blade; and

a detachable unit combined with the main unit so as to be attachable and detachable from the main unit, the detachable unit supporting the other of the recording head and the platen roller and a fixed blade for cutting the recording sheet while sandwiching the recording sheet together with the movable blade when the movable blade undergoes sliding movement;

wherein the main unit comprises:

a movable blade holder for holding the movable blade; a reciprocating mechanism for causing the movable blade holder to linearly reciprocate along with rotation of a drive gear coupled to the movable blade motor;

a biasing member for biasing the movable blade through the movable blade holder in a direction of separating the movable blade from the fixed blade; and

a gear train mechanism for coupling the drive gear and the reciprocating mechanism to each other to transmit a rotational force of the drive gear to the reciprocating mechanism when the detachable unit is attached to the main unit, and for disconnecting the drive gear and the reciprocating mechanism from each other when the detachable unit is detached from the main unit; and

wherein the detachable unit is configured to move close to and away from the main unit along a sliding direction of the movable blade when the detachable unit is attached to and detached from the main unit.

2. A printer with a cutter according to claim 1, wherein: the recording head is provided on the detachable unit; and the platen roller is provided on the main unit.

3. A printer with a cutter according to claim 2; further comprising a platen roller motor mounted on the main frame of the main unit for driving the platen roller.

4. A printer with a cutter according to claim 1; wherein the main frame of the main unit supports the platen roller; and further comprising a platen roller motor supported by the main frame for driving the platen roller.

5. A printer with a cutter according to claim 1; wherein the platen roller has a part thereof exposed from an upper surface of the main frame.

6. A printer with a cutter according to claim 1; wherein the reciprocating mechanism is configured to undergo linear reciprocation movement to cause the movable blade held by the movable blade holder to slide with respect to the fixed blade so that the sliding movable blade overlaps and rides on the fixed blade to cut the recording sheet while the recording sheet is interposed between the movable and fixed blades.

7. A printer with a cutter according to claim 6; wherein the detachable unit is detachable from the main unit in a state in which the movable blade overlaps the fixed blade to allow the movable blade to be separated from the fixed blade.

8. A printer with a cutter according to claim 1; wherein the reciprocating mechanism is integrally formed in a lower end portion of the movable blade holder.

9. A printer with a cutter according to claim 1; wherein the reciprocating mechanism reciprocates the movable blade holder linearly in an up-and-down direction along with rotation of the drive gear coupled to the movable blade motor; and wherein the biasing member is attached between the movable blade holder and a bottom wall portion of the main frame and biases the movable blade holder in a downward direction of separating the movable blade from the fixed blade.

10. A printer with a cutter according to claim 1; wherein the gear train mechanism is provided between the reciprocating mechanism and the drive gear.

11. A printer with a cutter for cutting a recording sheet after printing is performed on the recording sheet, the printer comprising:

a main unit having one of a platen roller and a recording head, and having a movable blade, a movable blade holder that holds the movable blade, a reciprocating mechanism that causes the movable blade holder to undergo linear reciprocating movement to cause the movable blade to undergo sliding movement, a drive gear that undergoes rotational movement to drive the reciprocating mechanism, a movable blade motor that rotationally drives the drive gear, and a gear train mechanism that transmits a rotational force of the drive gear to the reciprocating mechanism; and

a detachable unit having the other of the platen roller and the recording head, and having a fixed blade for cutting the recording sheet while the recording sheet is interposed between the movable and fixed blades and the movable blade undergoes sliding movement, the detachable unit being combined with the main unit so as to be attachable and detachable from the main unit and being configured to move close to and away from the main unit along a sliding direction of the movable blade when the detachable unit is attached to and detached from the main unit.

12. A printer with a cutter according to claim 11; further comprising a biasing member for biasing the movable blade through the movable blade holder in a direction of separating the movable blade from the fixed blade.

13. A printer with a cutter according to claim 11; wherein the gear train mechanism couples the drive gear and the reciprocating mechanism to each other to transmit a rota-

tional force of the drive gear to the reciprocating mechanism when the detachable unit is attached to the main unit, and disconnects the drive gear and the reciprocating mechanism from each other when the detachable unit is detached from the main unit.

14. A printer with a cutter according to claim 11; wherein the platen roller is mounted on the main unit and the recording head is mounted on the detachable unit; and further comprising a platen roller motor mounted on the main unit for driving the platen roller.

15. A printer with a cutter according to claim 14; wherein the platen roller has a part thereof exposed from an upper surface of a main frame of the main unit.

16. A printer with a cutter according to claim 11; wherein the reciprocating mechanism is integrally formed in a lower end portion of the movable blade holder; and wherein the gear train mechanism is provided between the reciprocating mechanism and the drive gear.

17. A printer with a cutter for cutting a recording sheet after printing is performed on the recording sheet, the printer comprising:

a main unit having a platen roller, a platen roller motor for driving the platen roller, a movable blade, a movable blade holder that holds the movable blade, a reciprocating mechanism for causing the movable blade holder to reciprocate along with rotation of a drive gear, and a movable blade motor for rotationally driving the drive gear;

a detachable unit having a recording head and having a fixed blade for cutting the recording sheet in cooperation with the movable blade, the detachable unit being combined with the main unit so as to be attachable and detachable from the main unit and being configured to move close to and away from the main unit along a reciprocating direction of the movable blade when the detachable unit is attached to and detached from the main unit; and

a gear train mechanism for coupling the drive gear and the reciprocating mechanism to each other to transmit a rotational force of the drive gear to the reciprocating mechanism when the detachable unit is attached to the main unit, and for disconnecting the drive gear and the reciprocating mechanism from each other when the detachable unit is detached from the main unit.

18. A printer with a cutter according to claim 17; further comprising a biasing member for biasing the movable blade through the movable blade holder in a direction of detaching the movable blade from the fixed blade.

19. A printer with a cutter according to claim 17; wherein the platen roller has a part thereof exposed from an upper surface of a main frame of the main unit.

20. A printer with a cutter according to claim 17; wherein the reciprocating mechanism is integrally formed in a lower end portion of the movable blade holder; and wherein the gear train mechanism is provided between the reciprocating mechanism and the drive gear.