



US008672830B2

(12) **United States Patent**
Dlugos, Jr. et al.

(10) **Patent No.:** **US 8,672,830 B2**
(45) **Date of Patent:** **Mar. 18, 2014**

(54) **IMPLANTABLE RESTRICTION SYSTEM WITH RELEASE MECHANISM**

(75) Inventors: **Daniel F. Dlugos, Jr.**, Middletown, OH (US); **Thomas E. Adams**, Loveland, OH (US); **Randal T. Byrum**, South Lebanon, OH (US); **Toralf Bork**, Enges (CH); **Christine H. Chen**, Cincinnati, OH (US); **Sean P. Conlon**, Loveland, OH (US); **Rocco Crivelli**, Bellinzona (CH); **Dean L. Garner**, Cincinnati, OH (US); **Alec J. Ginggen**, Plymouth, MA (US); **David T. Krumanaker**, Cincinnati, OH (US); **Amy L. Marcotte**, Mason, OH (US); **Anil K. Nalagatla**, Mason, OH (US); **Bret W. Smith**, Kings Mill, OH (US); **Jeffrey S. Swayze**, Hamilton, OH (US); **Richard W. Timm**, Cincinnati, OH (US)

(73) Assignee: **Ethicon Endo-Surgery, Inc.**, Cincinnati, OH (US)

(*) Notice: Subject to any disclaimer, the term of this patent is extended or adjusted under 35 U.S.C. 154(b) by 435 days.

(21) Appl. No.: **12/562,310**

(22) Filed: **Sep. 18, 2009**

(65) **Prior Publication Data**
US 2011/0071341 A1 Mar. 24, 2011

(51) **Int. Cl.**
A61F 2/00 (2006.01)
A61F 13/00 (2006.01)

(52) **U.S. Cl.**
USPC **600/37; 600/29; 128/897; 128/898; 128/899; 606/151**

(58) **Field of Classification Search**
USPC 600/37, 29; 128/897-899; 606/151
See application file for complete search history.

(56) **References Cited**

U.S. PATENT DOCUMENTS

5,449,368	A *	9/1995	Kuzmak	606/157
6,272,936	B1	8/2001	Oreper et al.	
6,547,801	B1	4/2003	Dargent et al.	
2005/0143766	A1 *	6/2005	Bachmann et al.	606/158
2006/0161041	A1 *	7/2006	Forsell	600/30
2006/0178564	A1 *	8/2006	Jones et al.	600/159
2006/0189888	A1	8/2006	Hassler et al.	
2006/0199997	A1	9/2006	Hassler et al.	
2006/0211913	A1	9/2006	Dlugos et al.	
2006/0241748	A1 *	10/2006	Lee et al.	623/2.37
2007/0167672	A1 *	7/2007	Dlugos et al.	600/37
2008/0249806	A1	10/2008	Dlugos et al.	
2009/0187202	A1	7/2009	Ortiz et al.	
2009/0264910	A1 *	10/2009	Laufer	606/169

* cited by examiner

Primary Examiner — Christine Matthews

Assistant Examiner — Sunita Reddy

(74) *Attorney, Agent, or Firm* — Welsh Flaxman & Gitler LLC

(57) **ABSTRACT**

An apparatus for regulating the functioning of a patient's organ or duct includes an elongated member having a first end and a second end. A fastener is disposed on the first end of the elongated member. The fastener is configured to engage the second end of the elongated member so that the elongated member forms a loop around the organ or duct. A tension element is disposed for movement within the elongated member. A drive element is associated with and engaging the tension element for causing the tension element to control the tension applied by the elongated member against a patient's body organ or duct. A release mechanism is provided for the tension element.

14 Claims, 39 Drawing Sheets

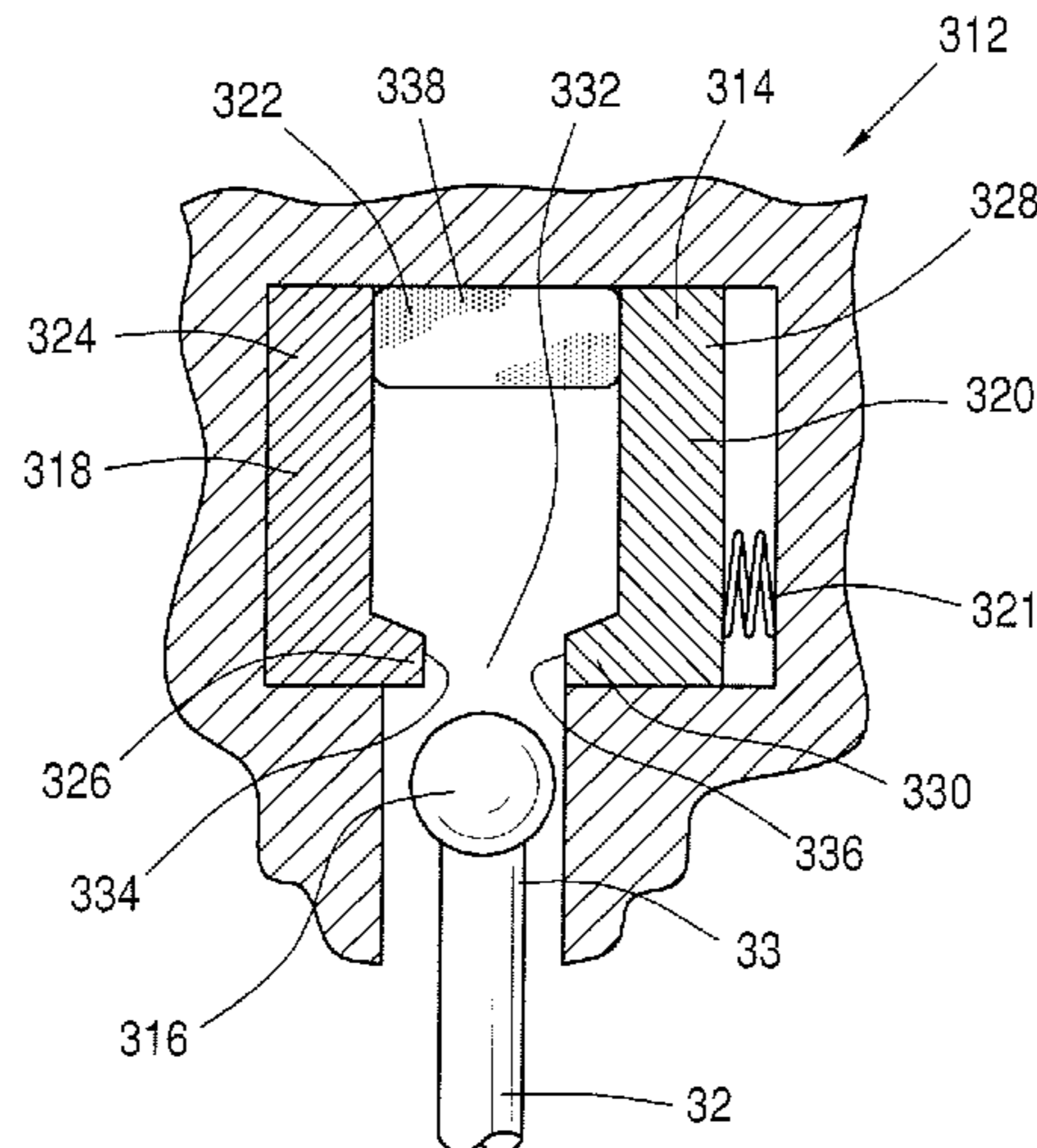

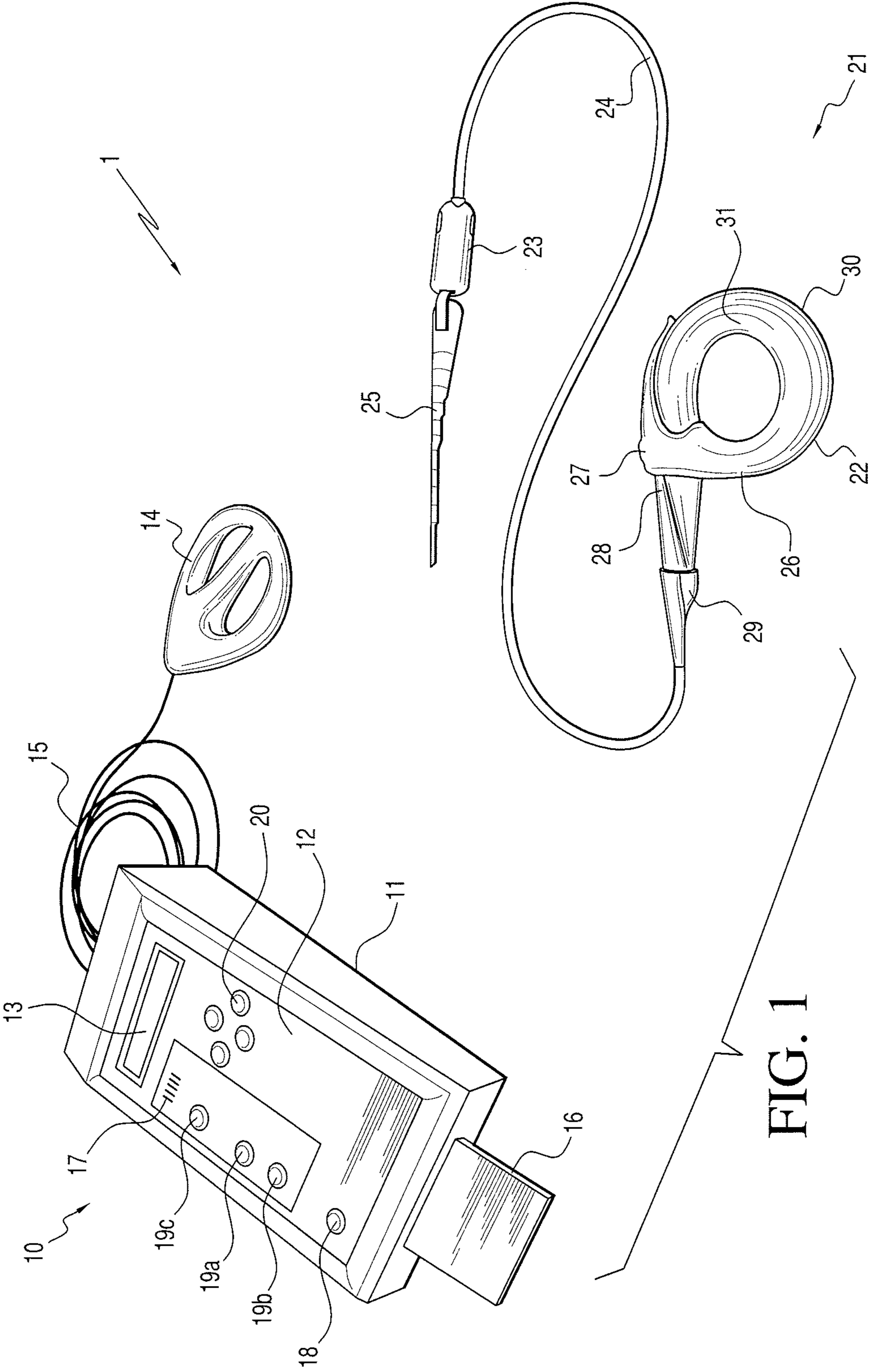

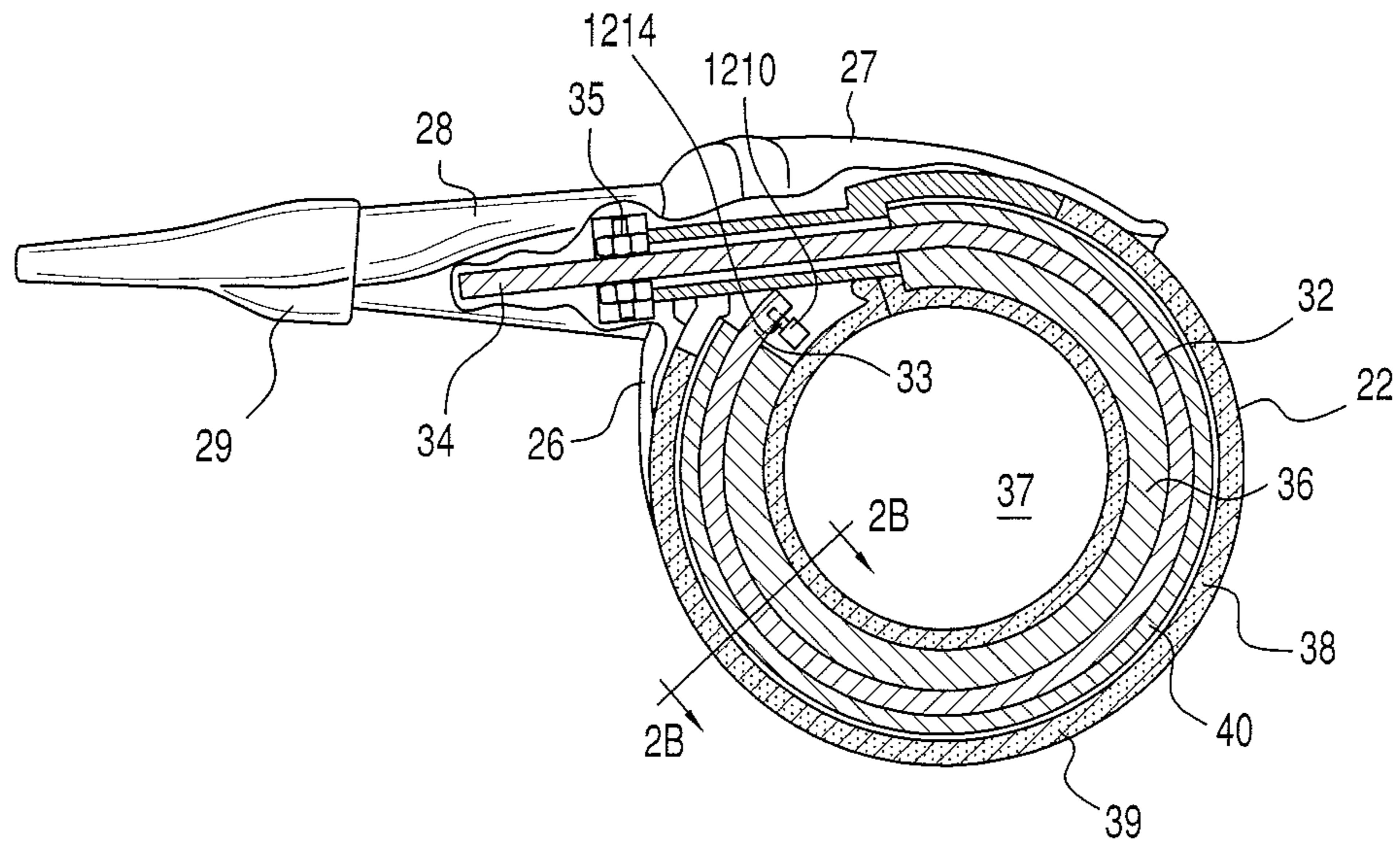
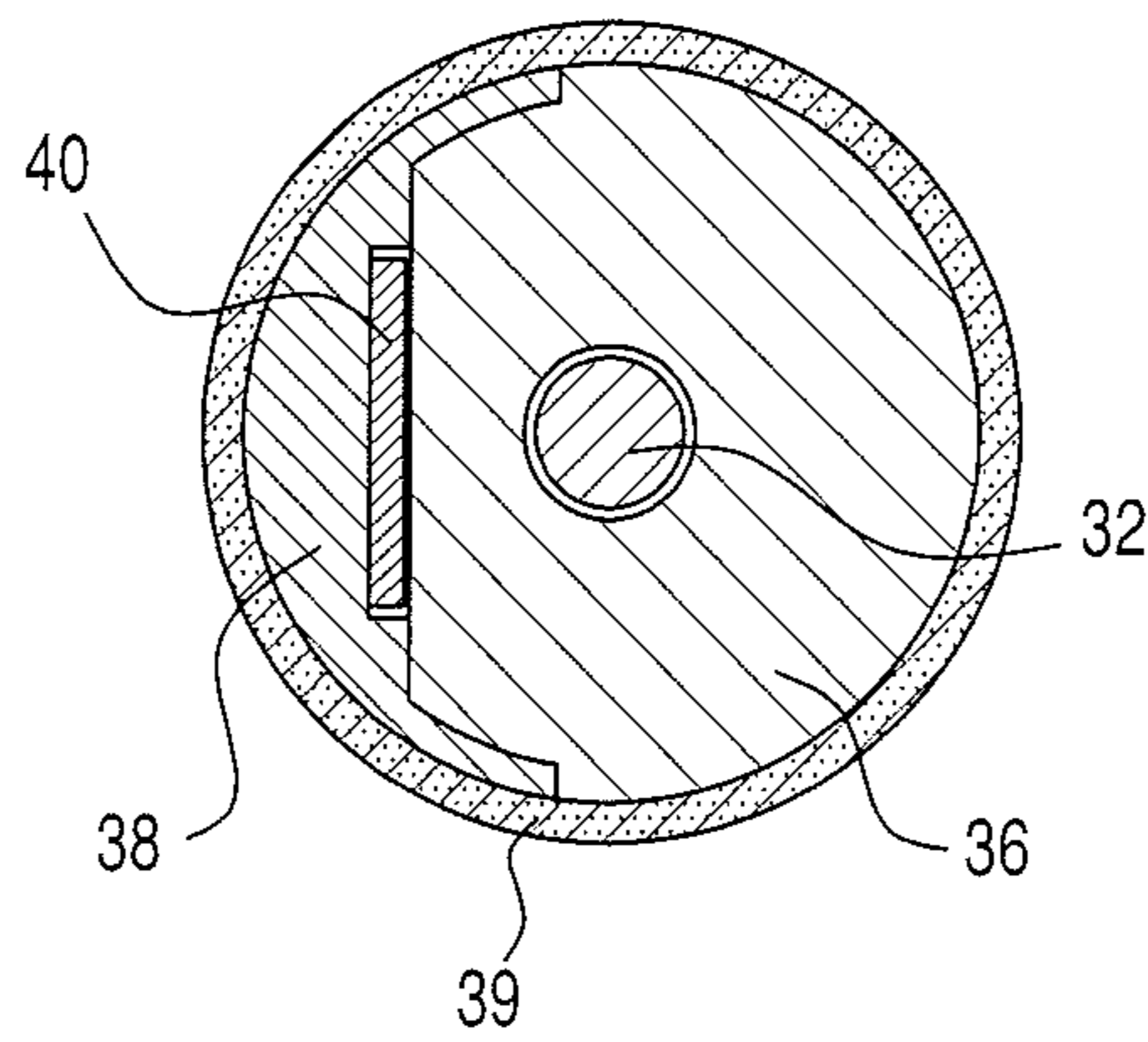

FIG. 2A

FIG. 2B



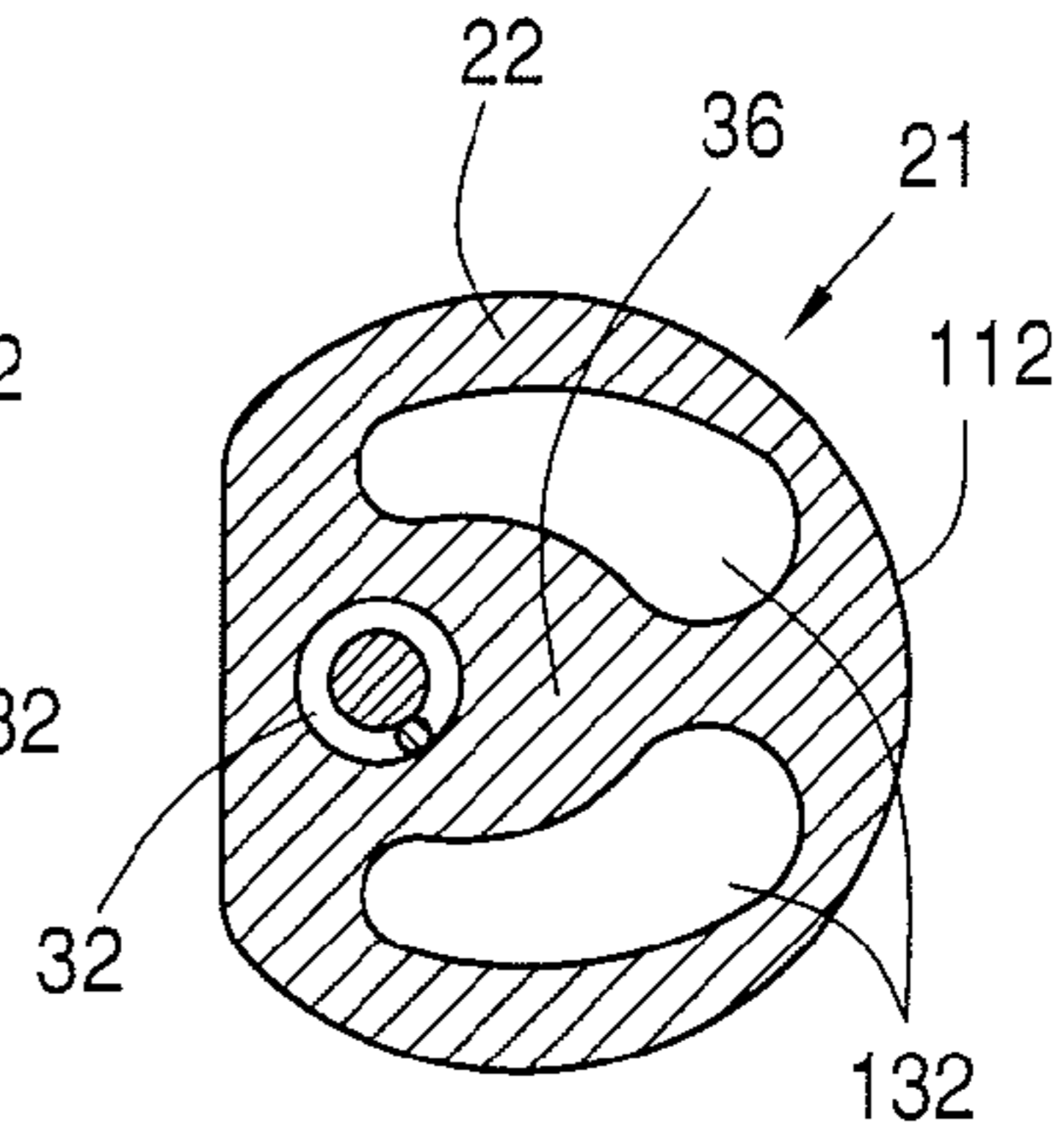
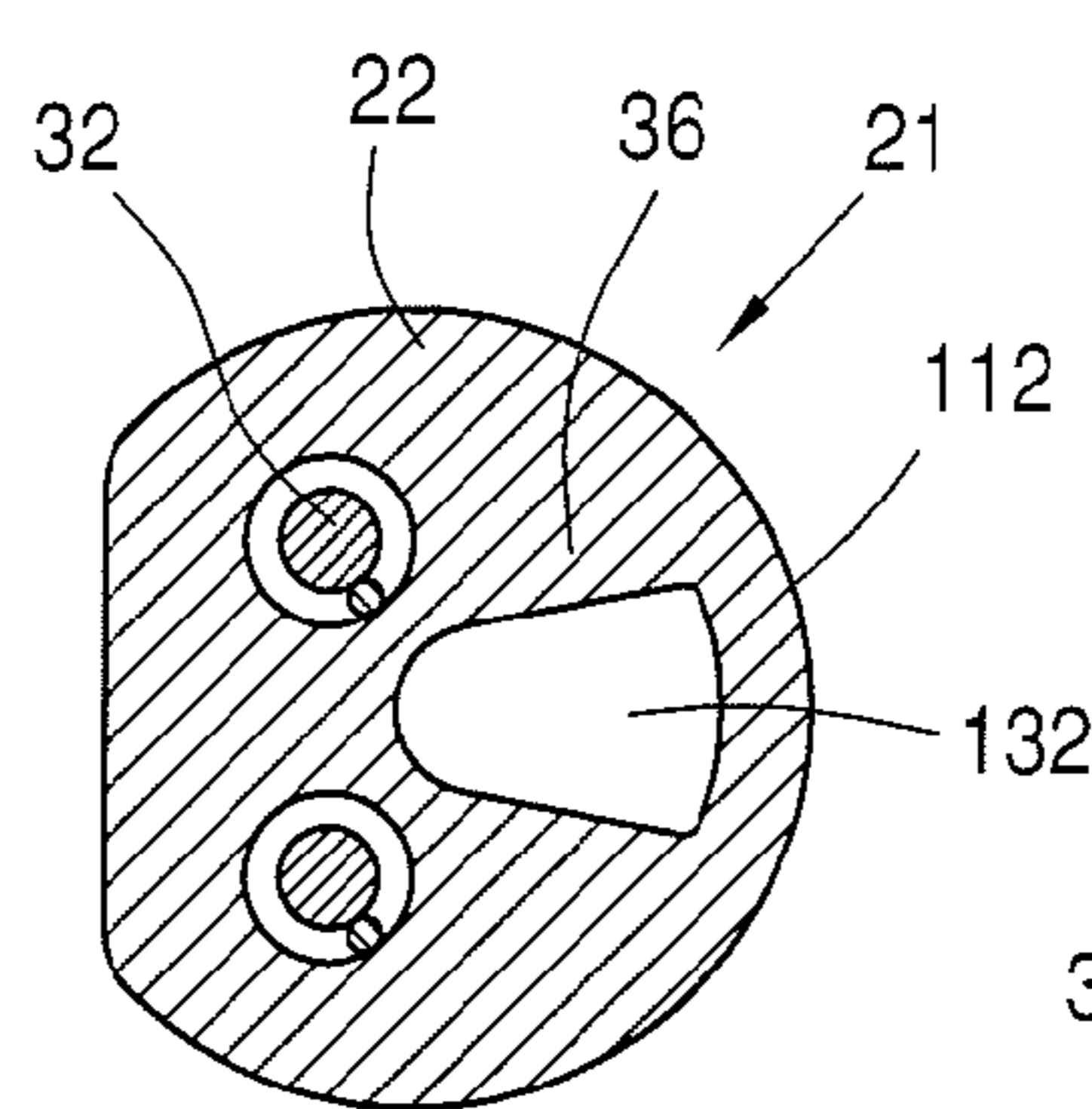
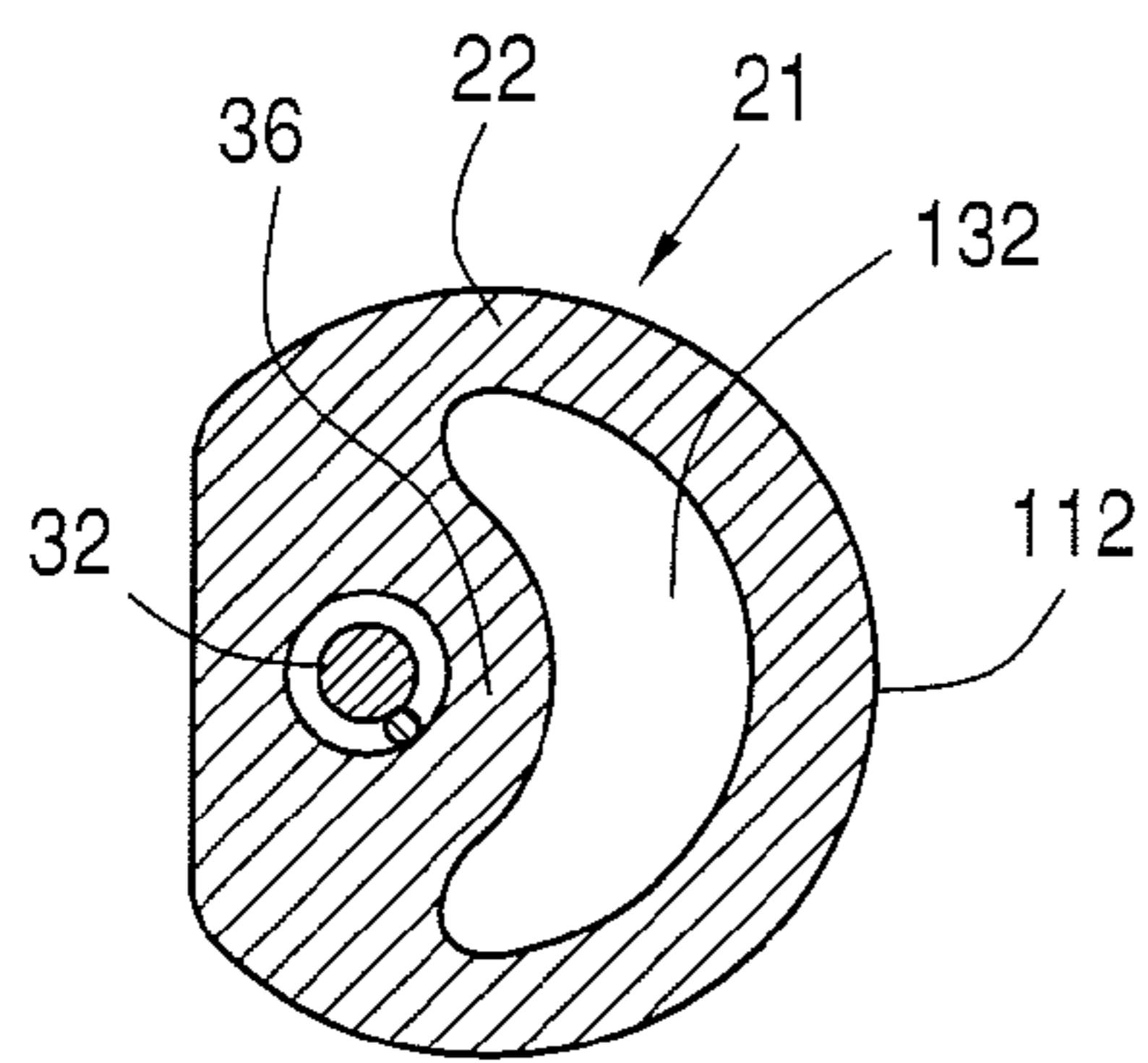
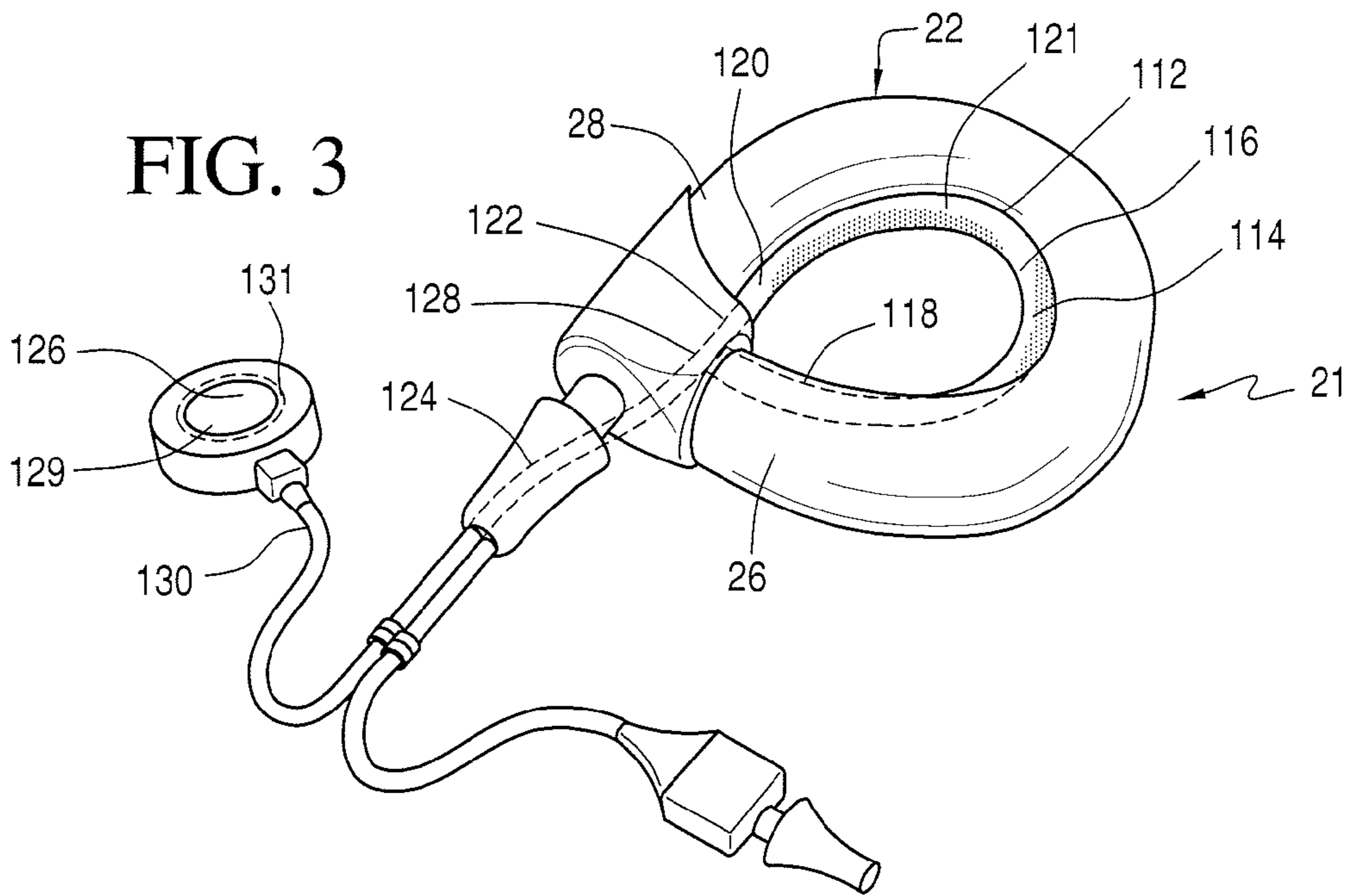

FIG. 4

FIG. 5

FIG. 6

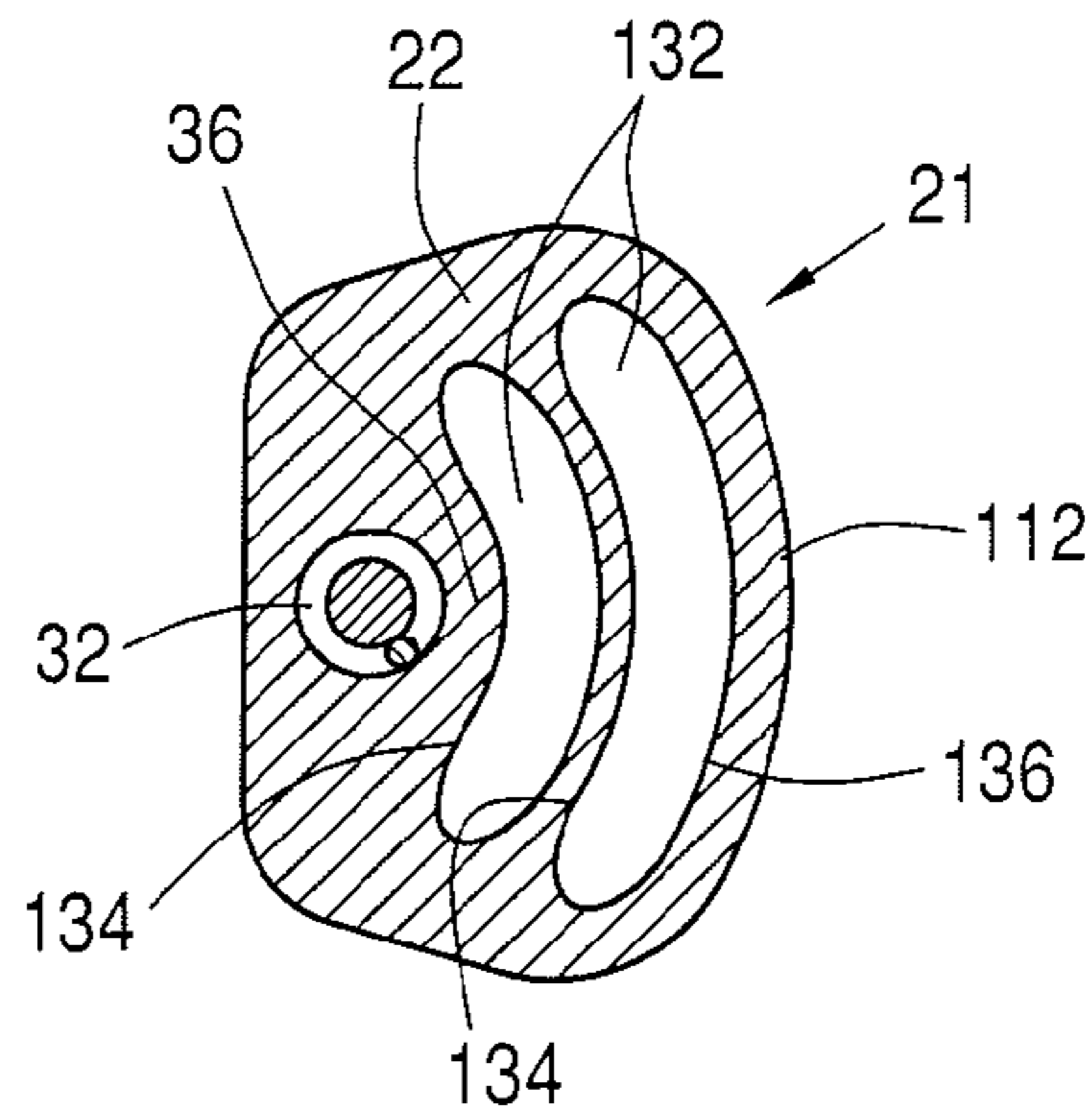
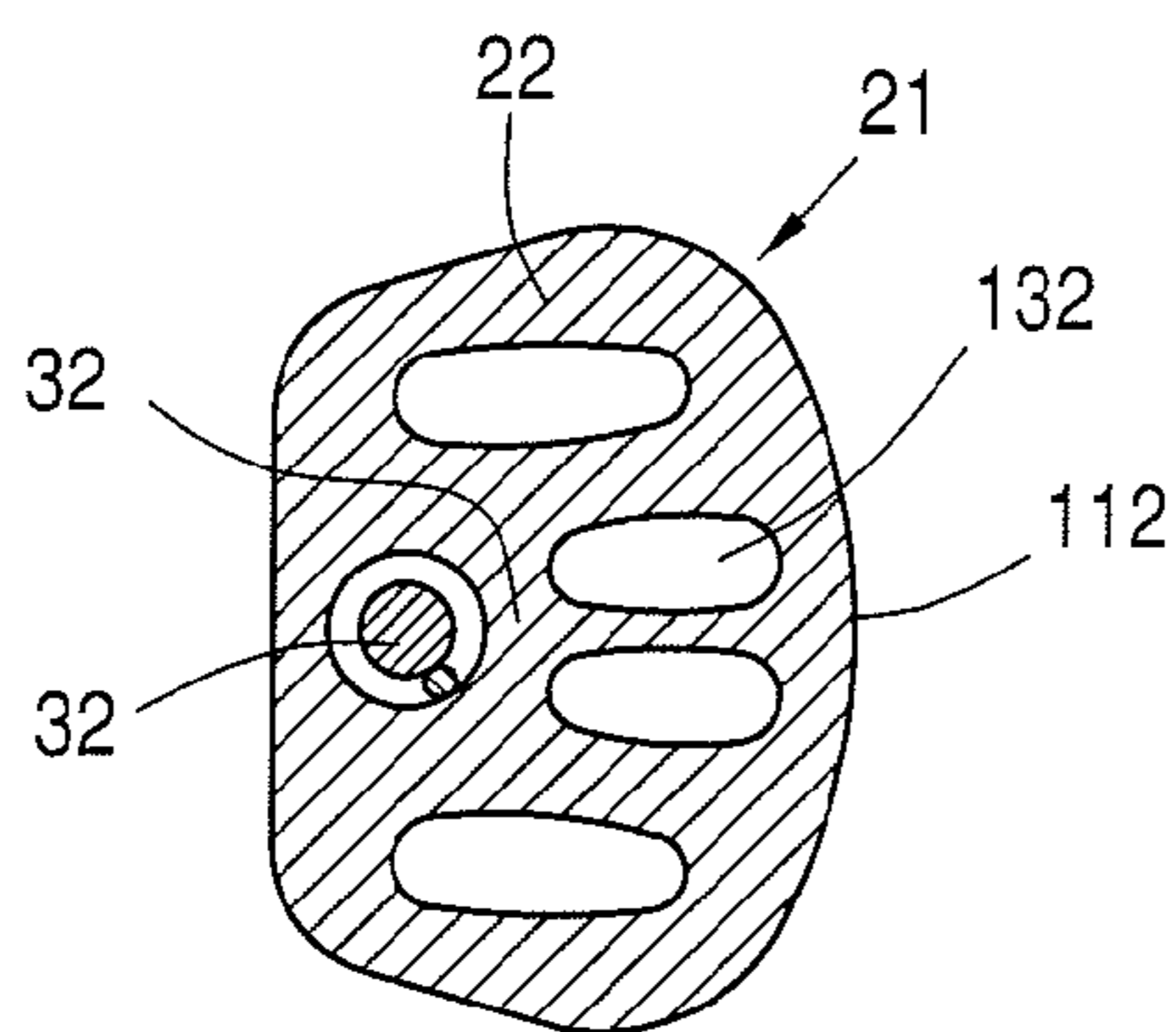

FIG. 7

FIG. 8

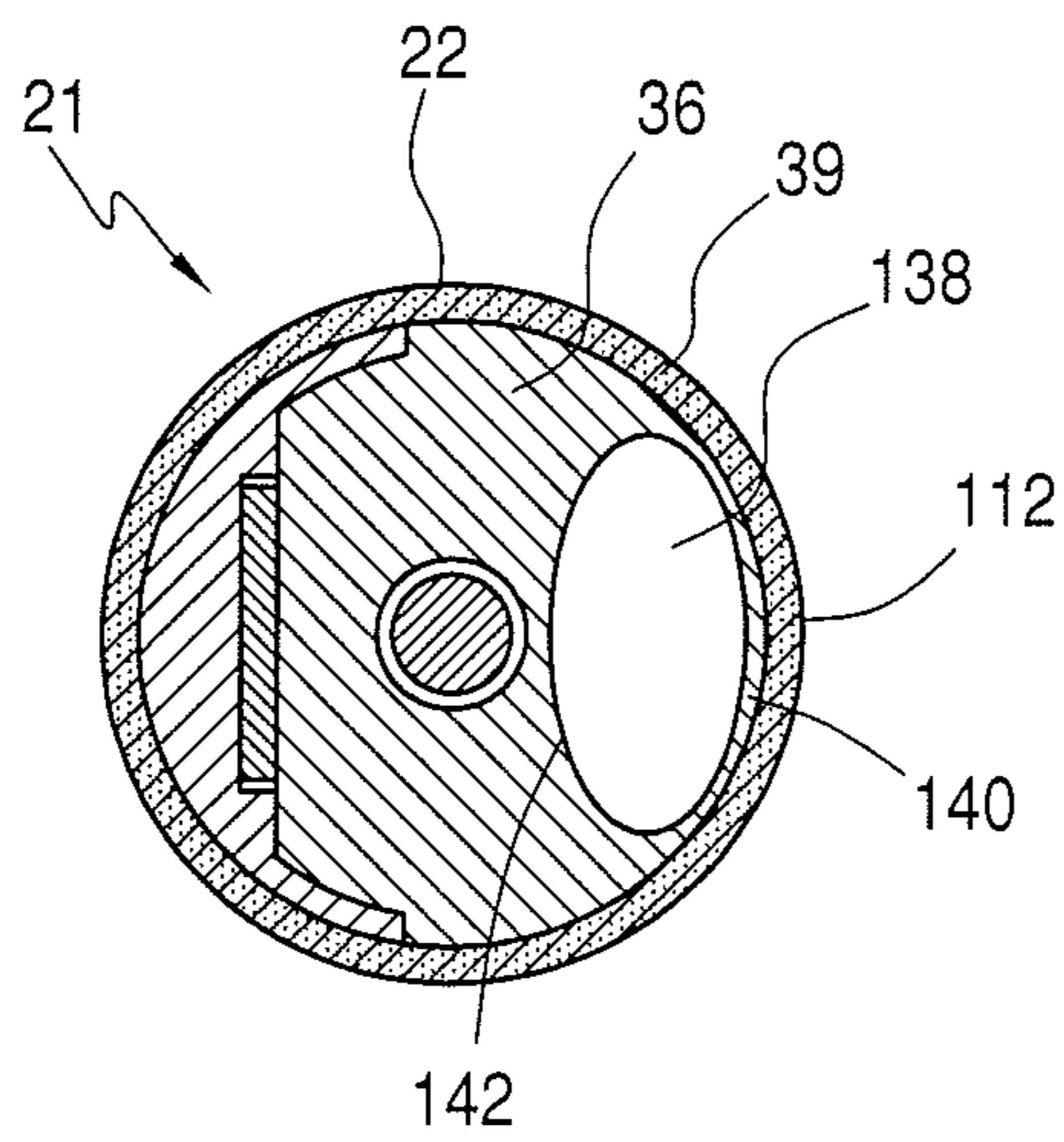

FIG. 9

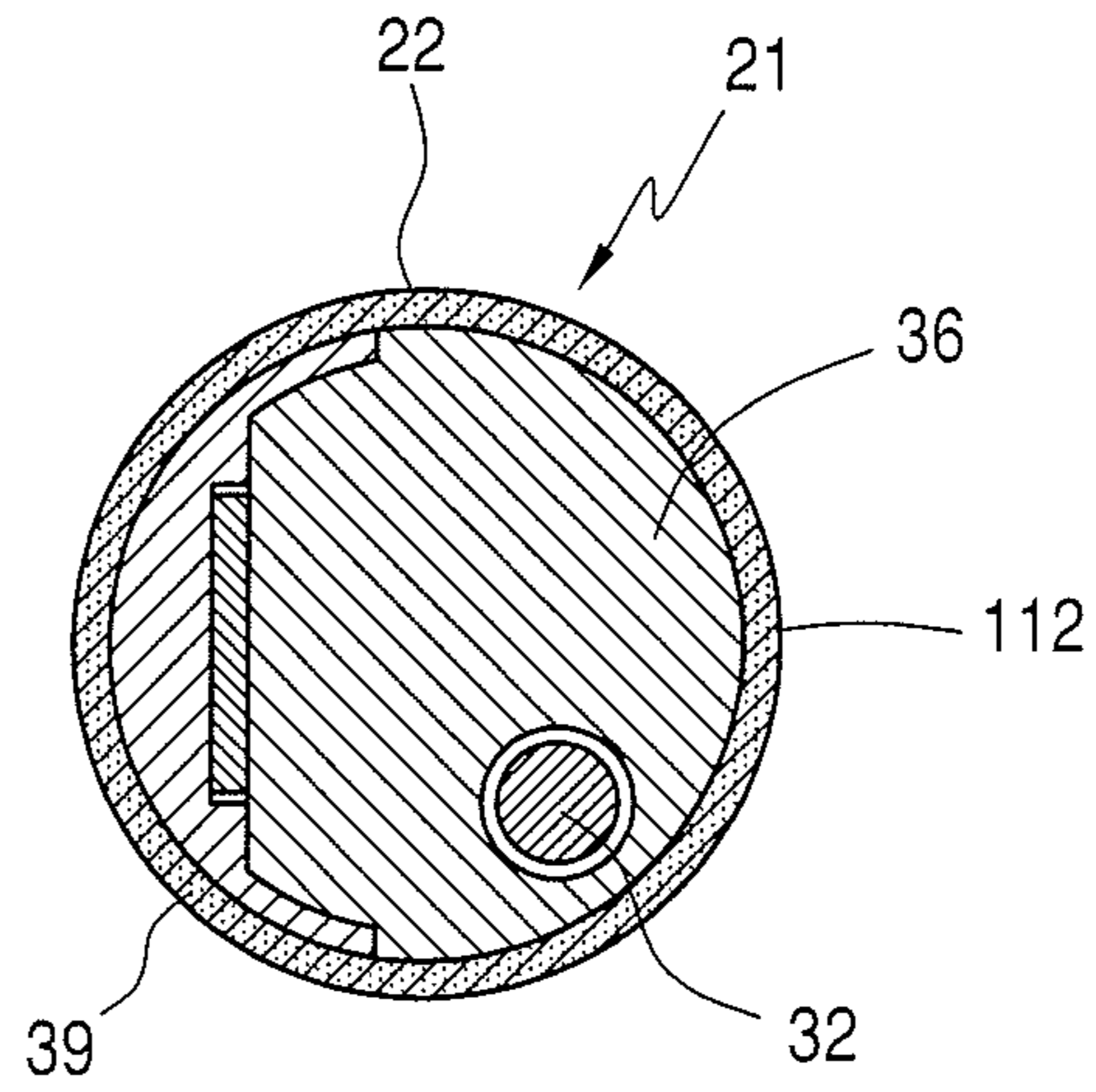

FIG. 10

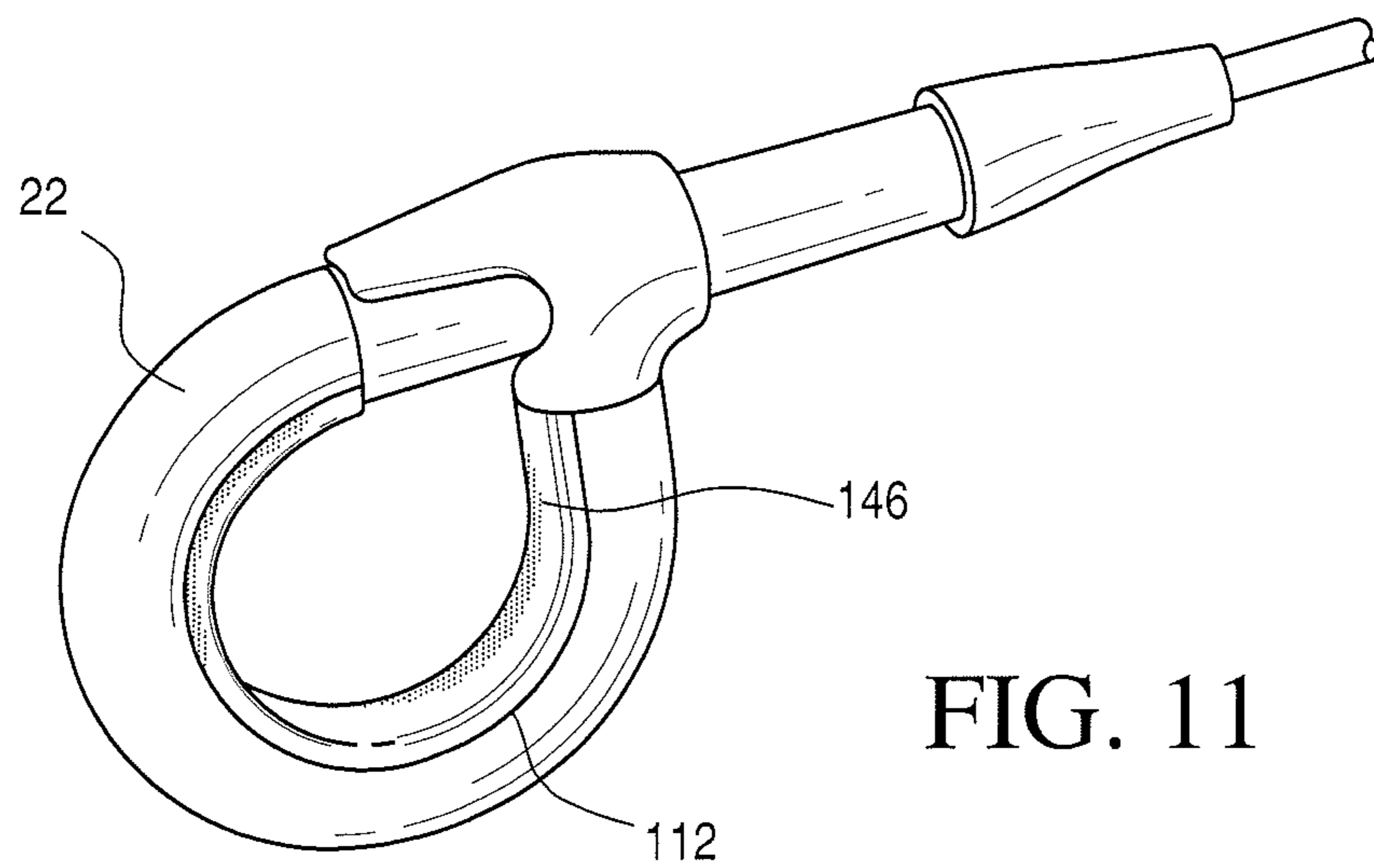

FIG. 11

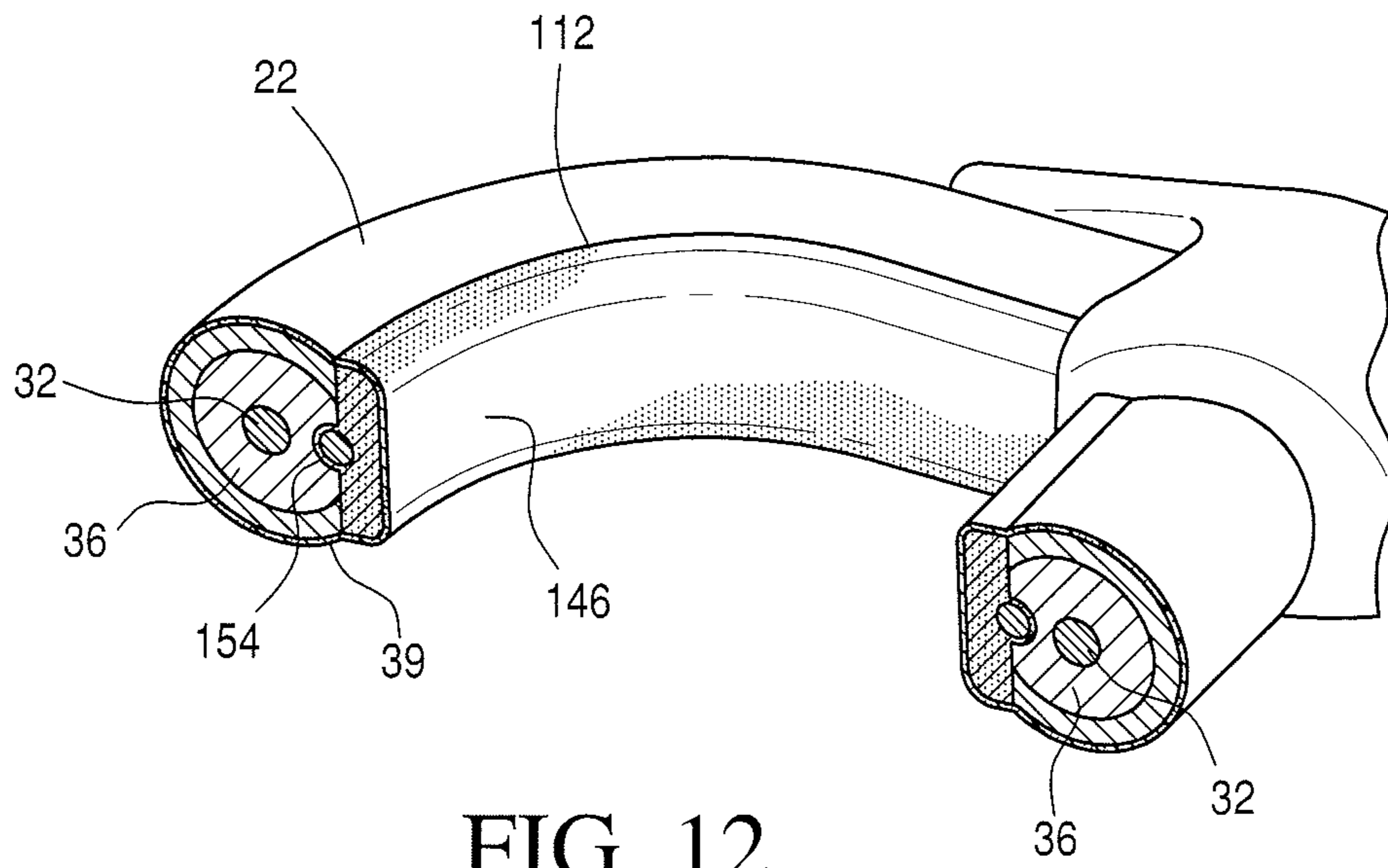

FIG. 12

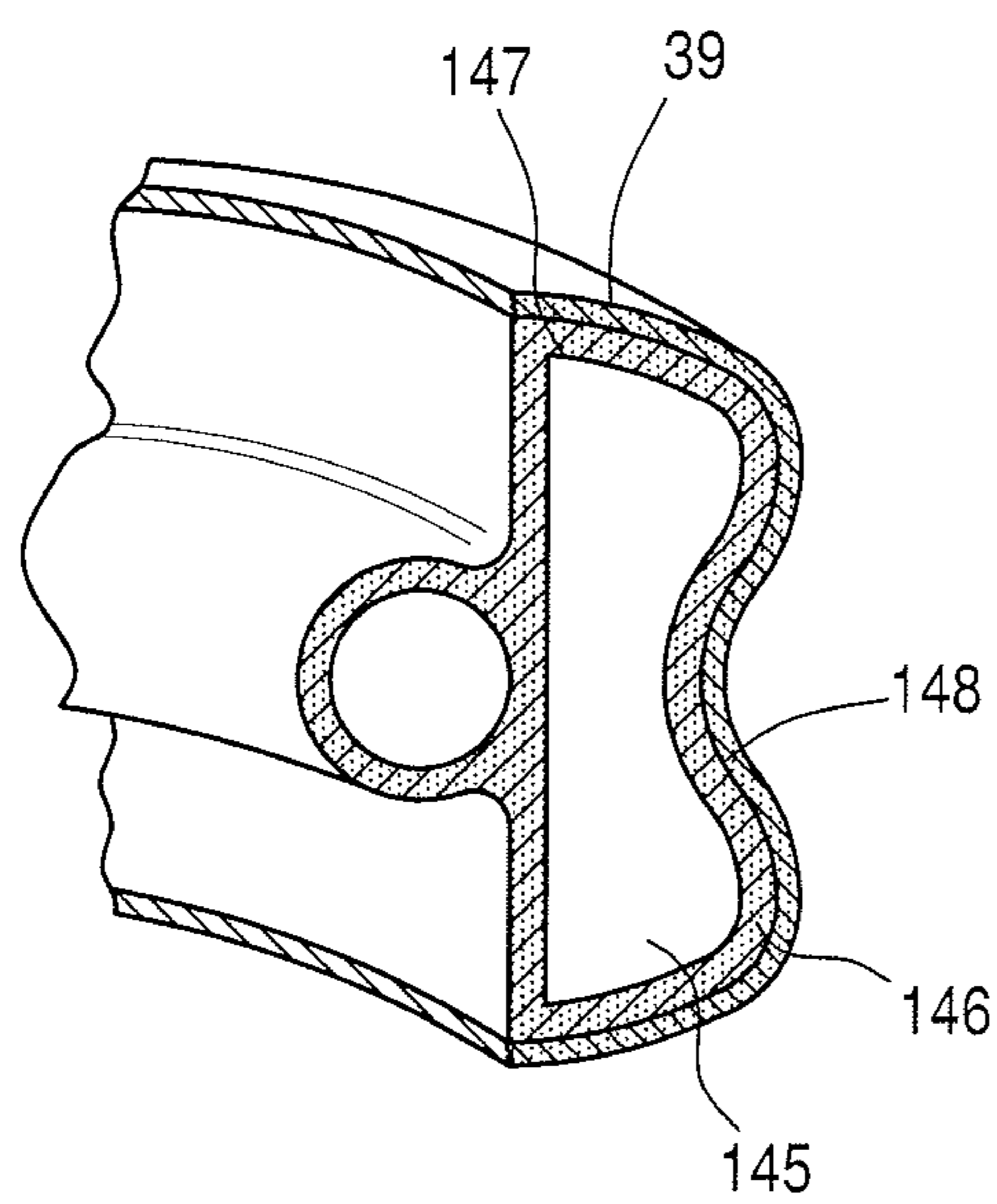

FIG. 14

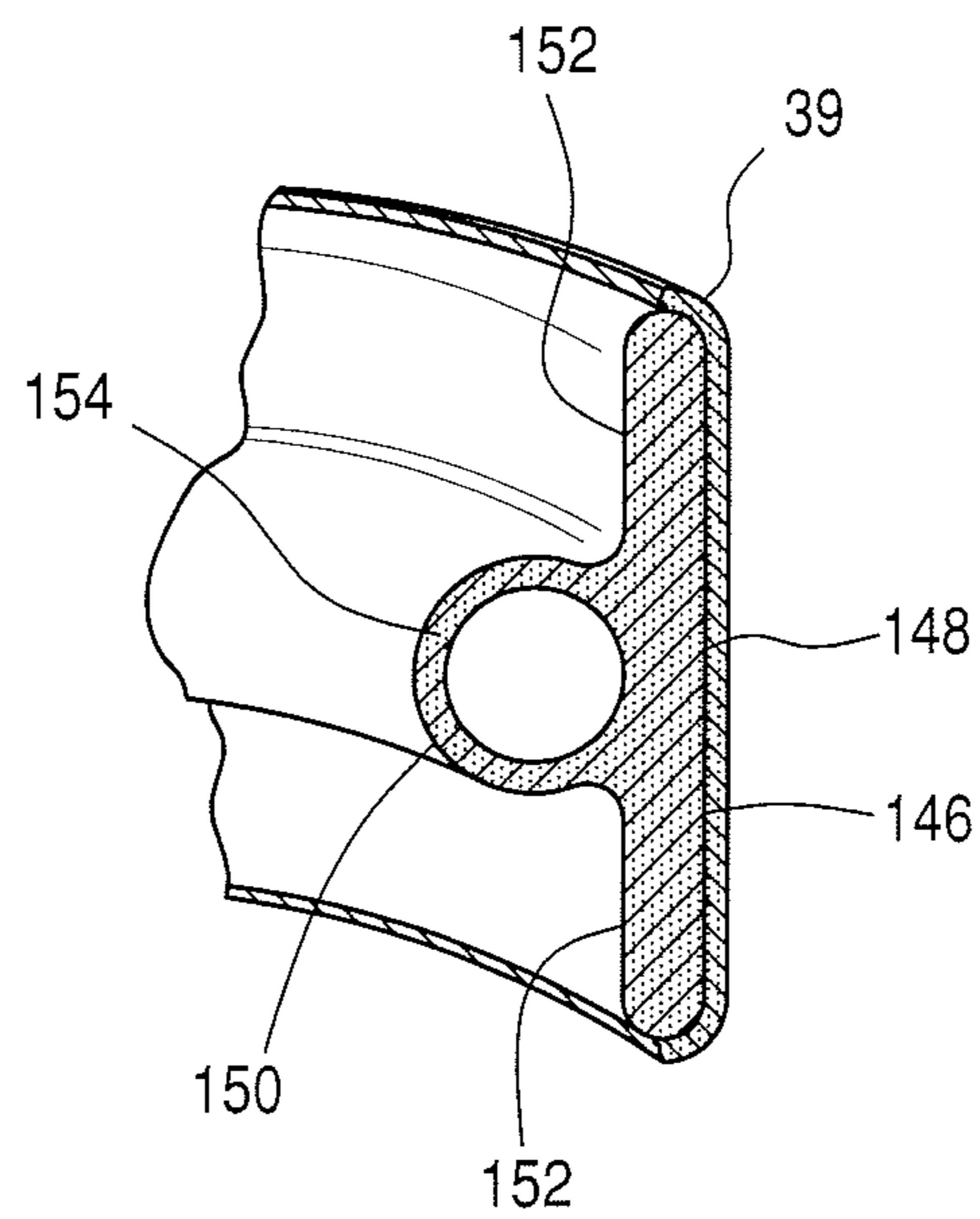

FIG. 13

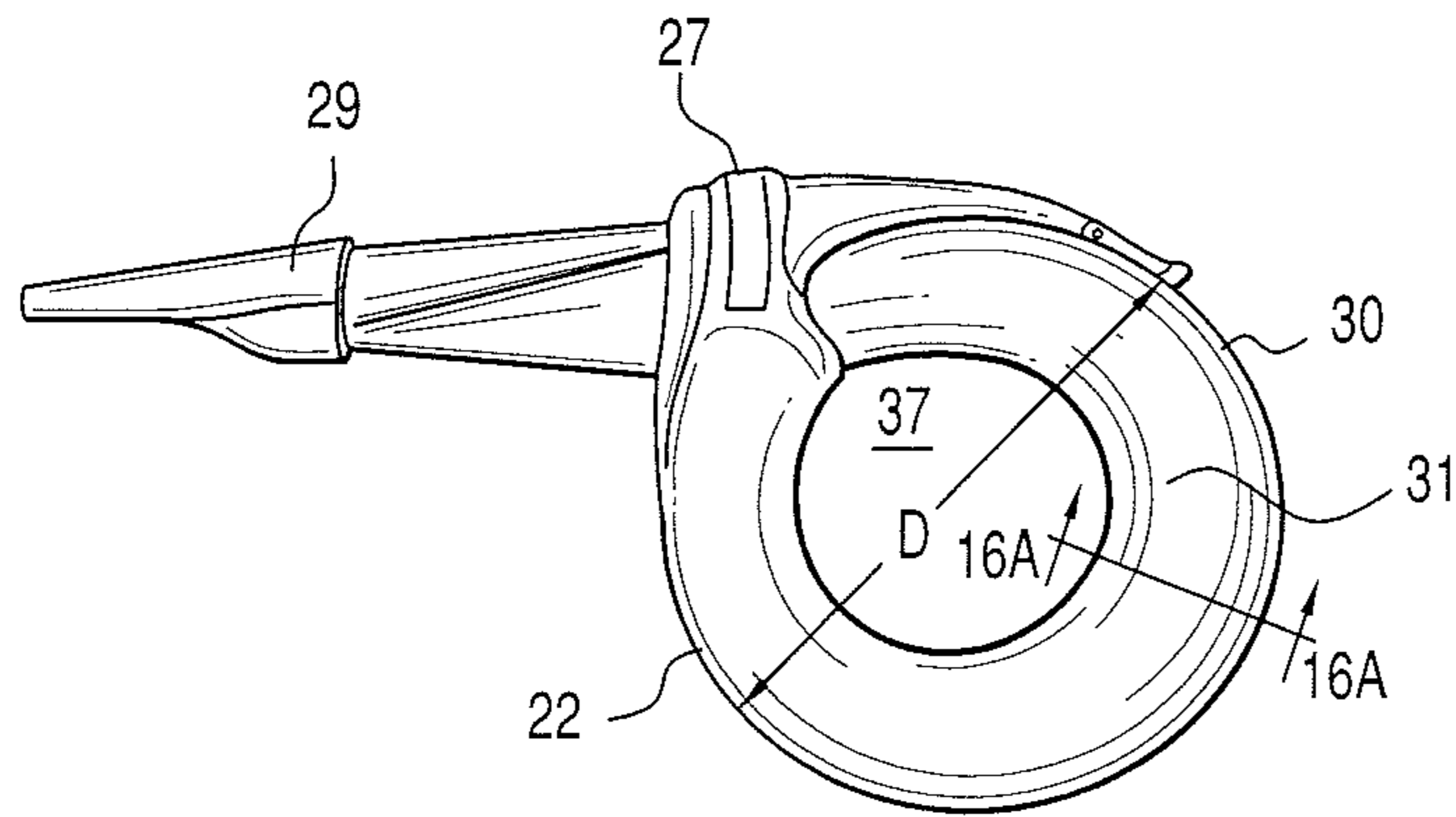

FIG. 15A

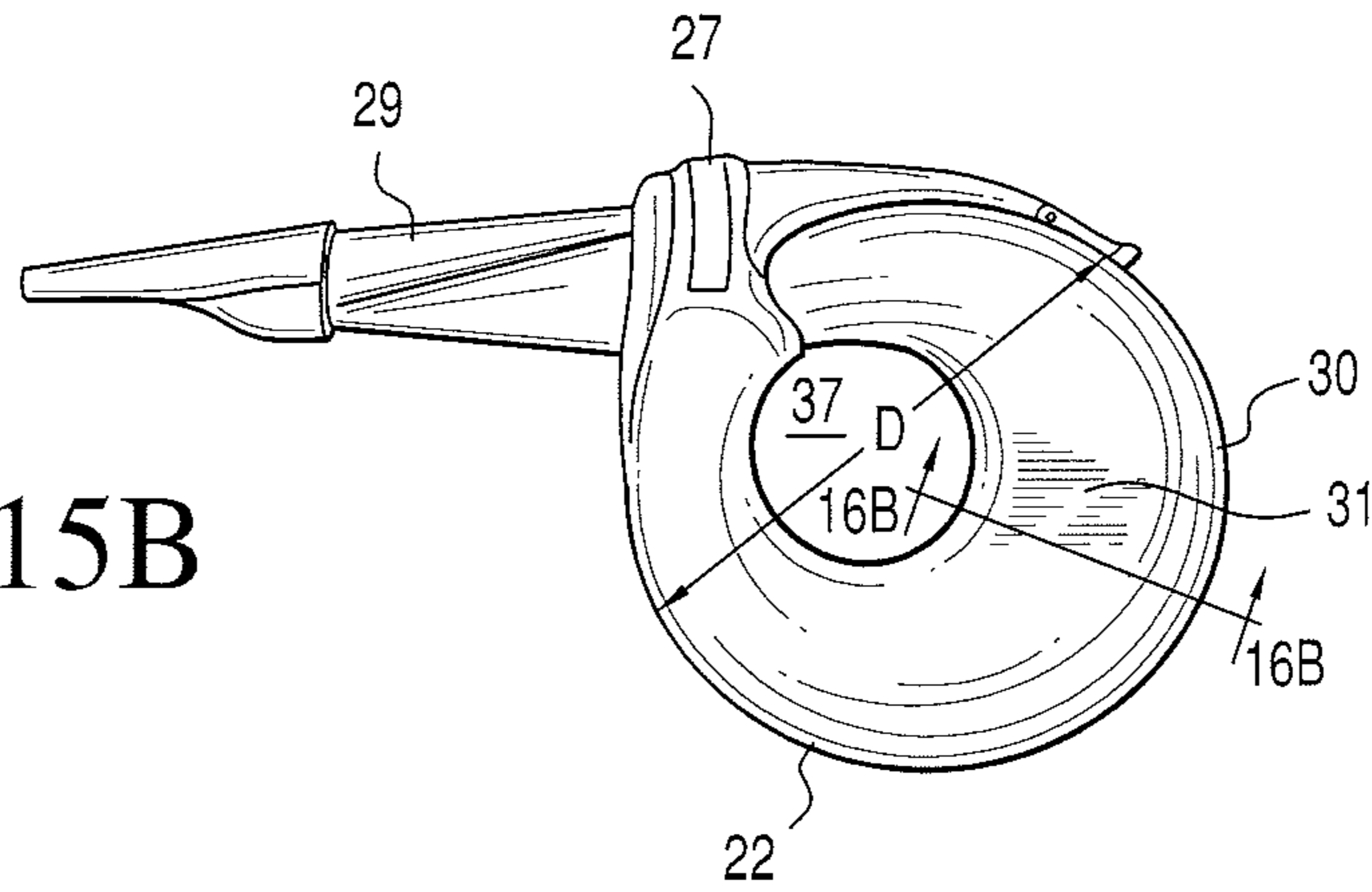

FIG. 15B

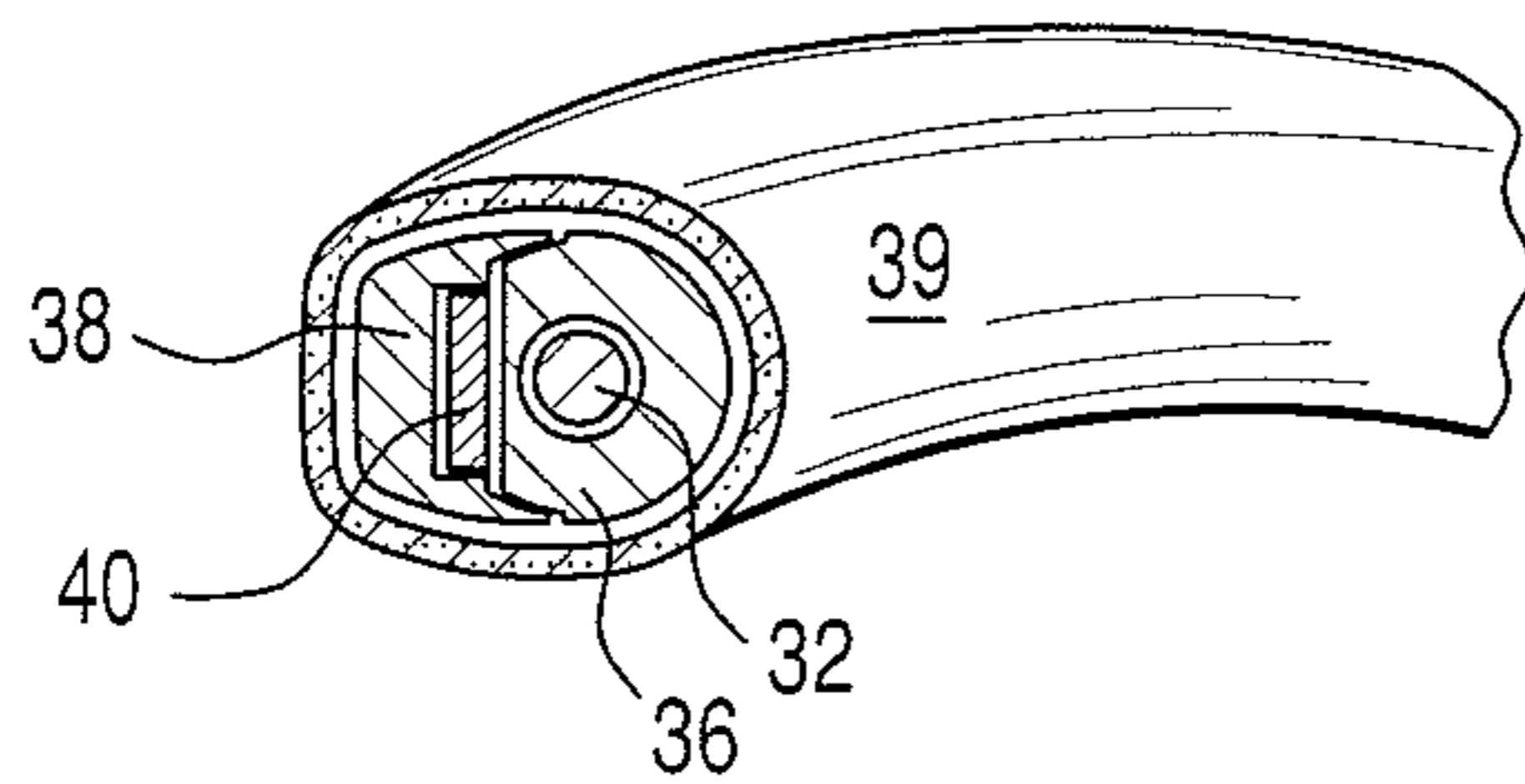

FIG. 16A

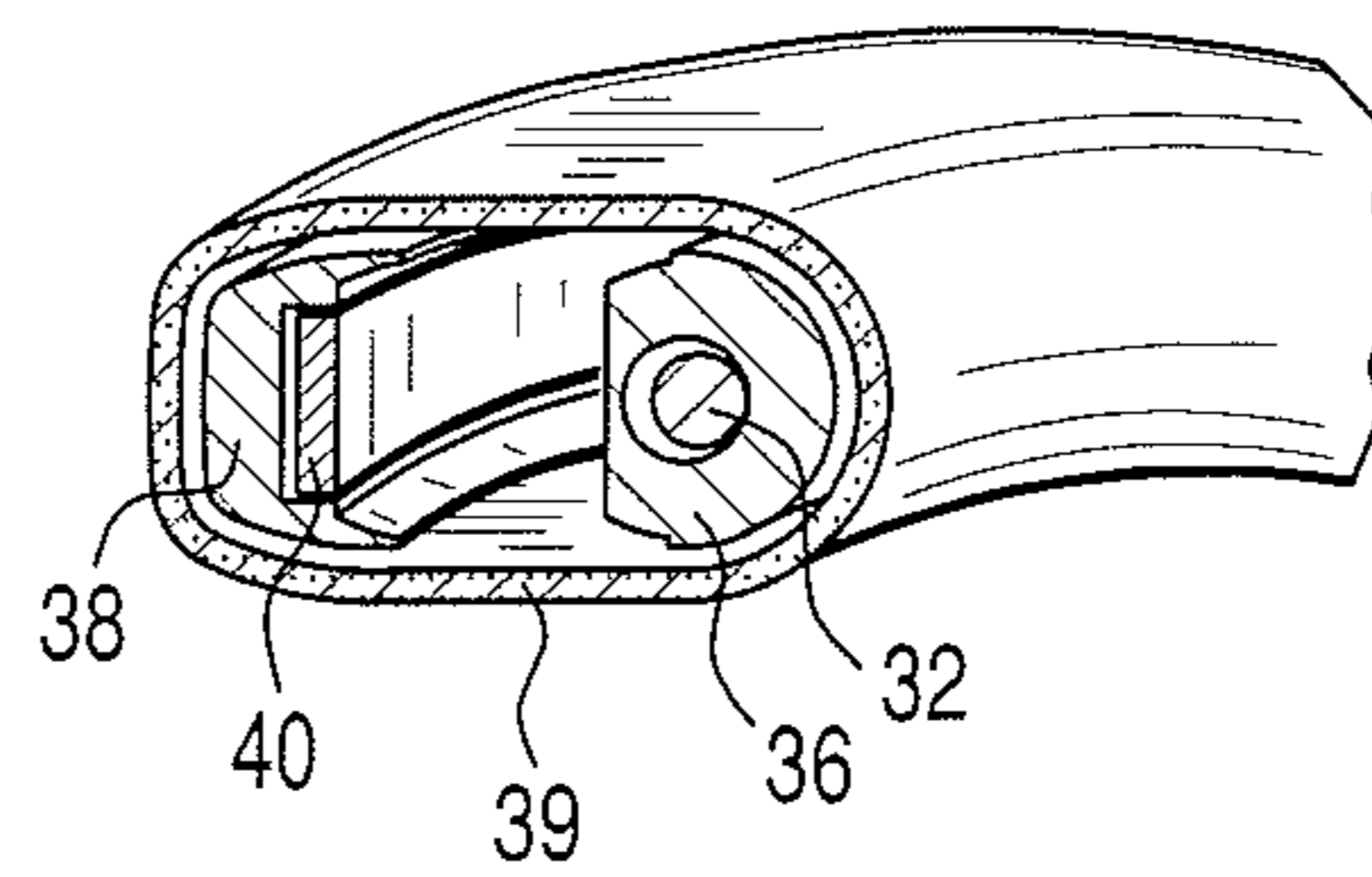

FIG. 16B

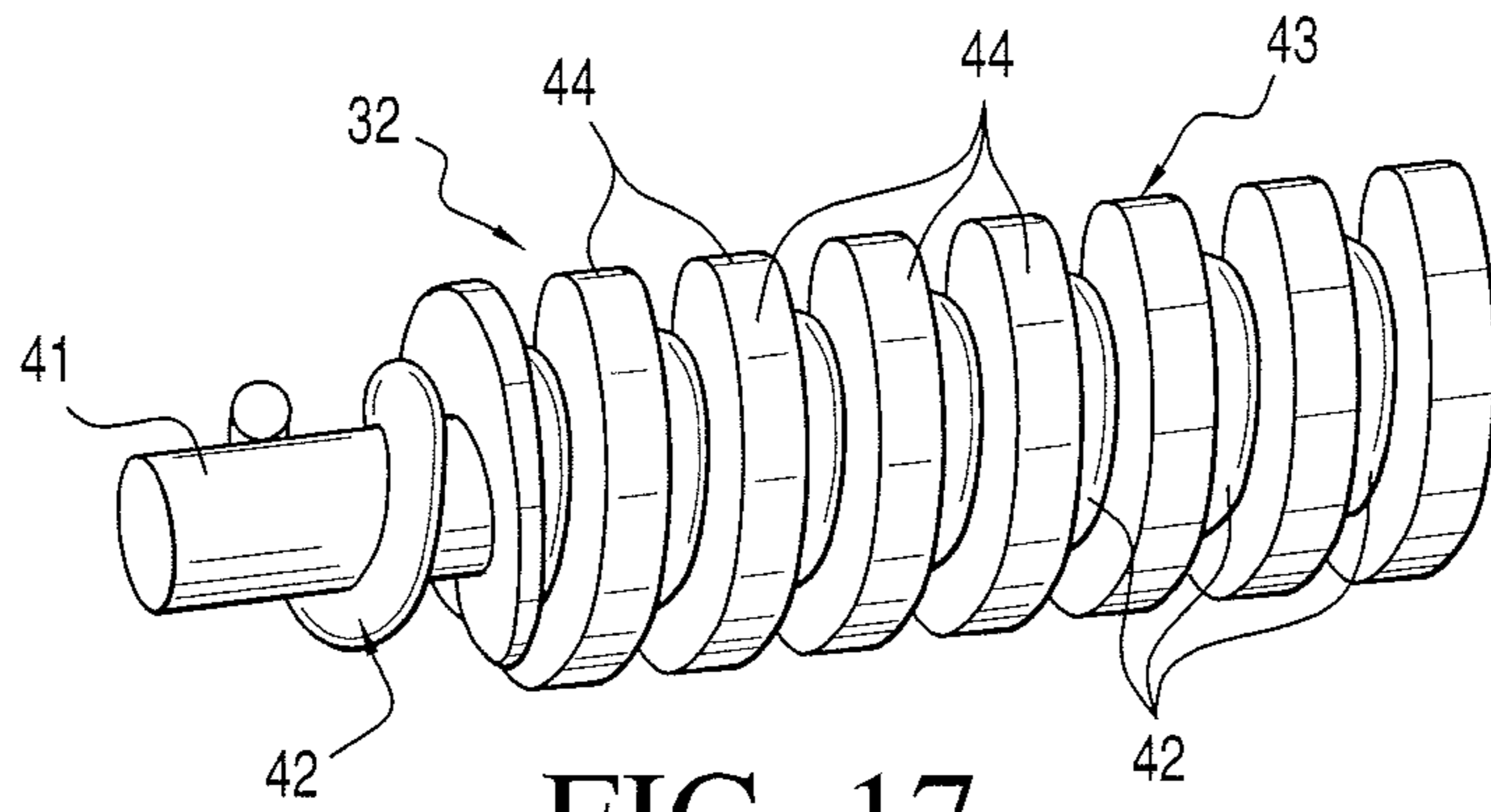

FIG. 17

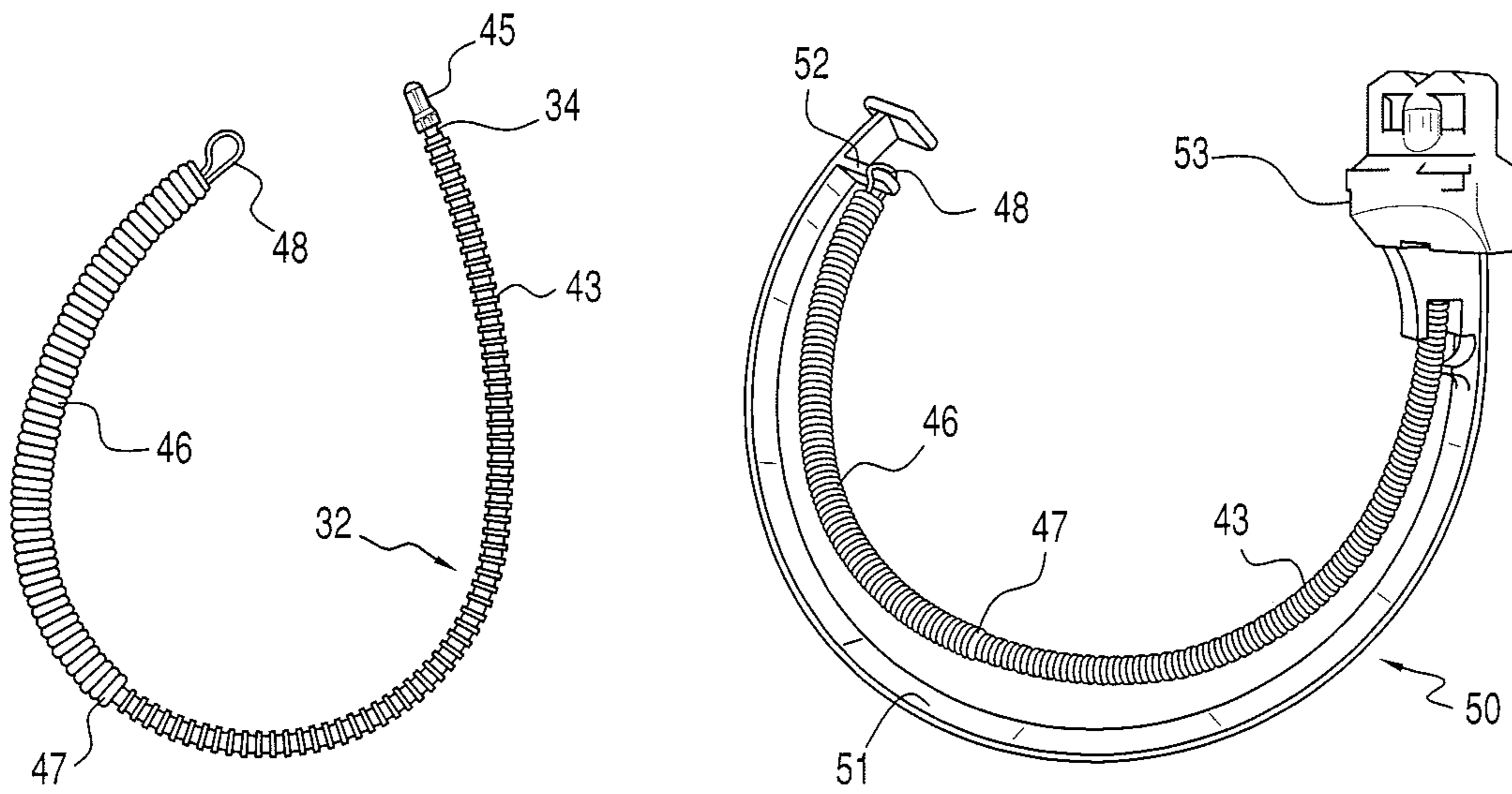

FIG. 18

FIG. 19

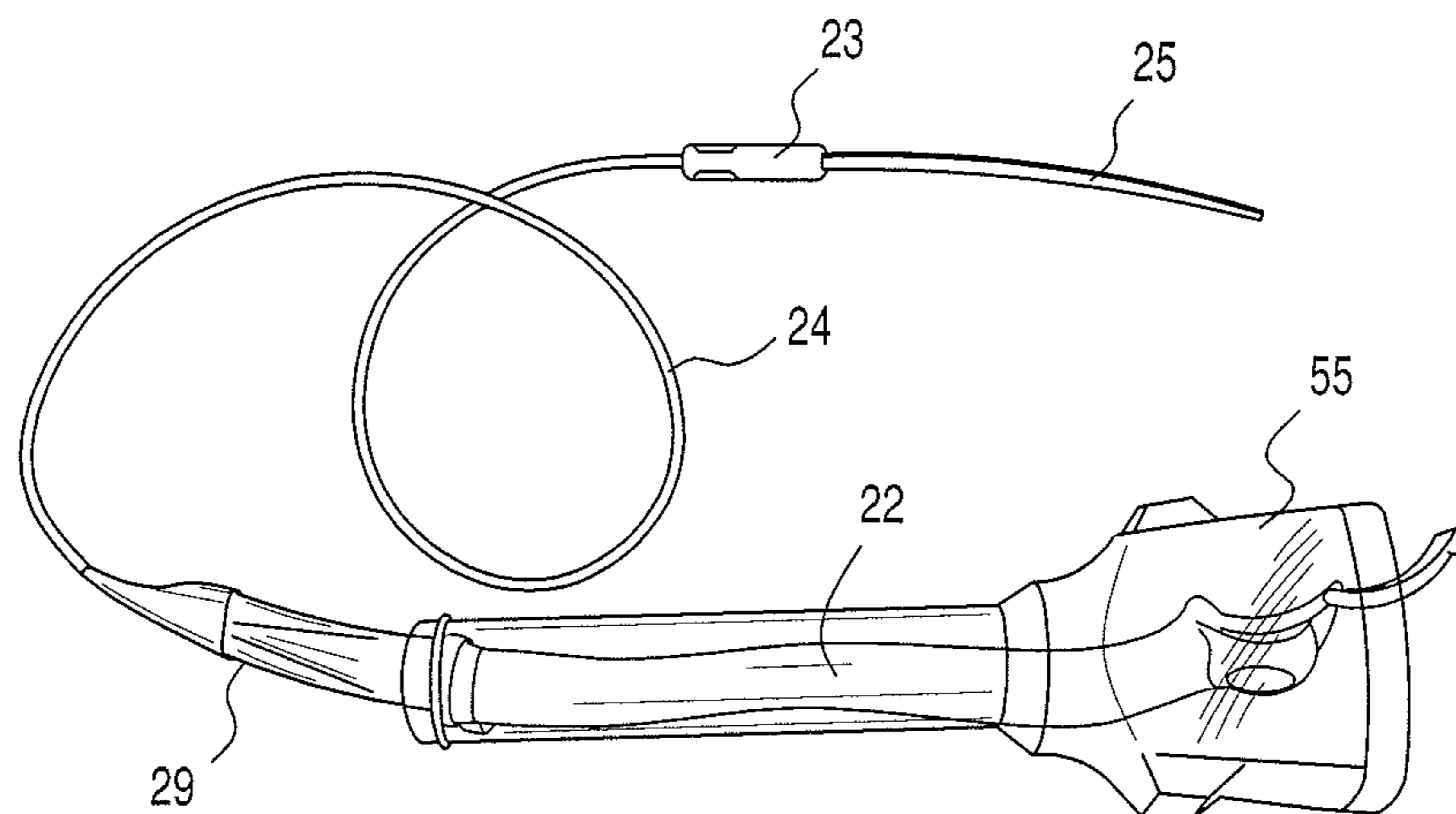

FIG. 20

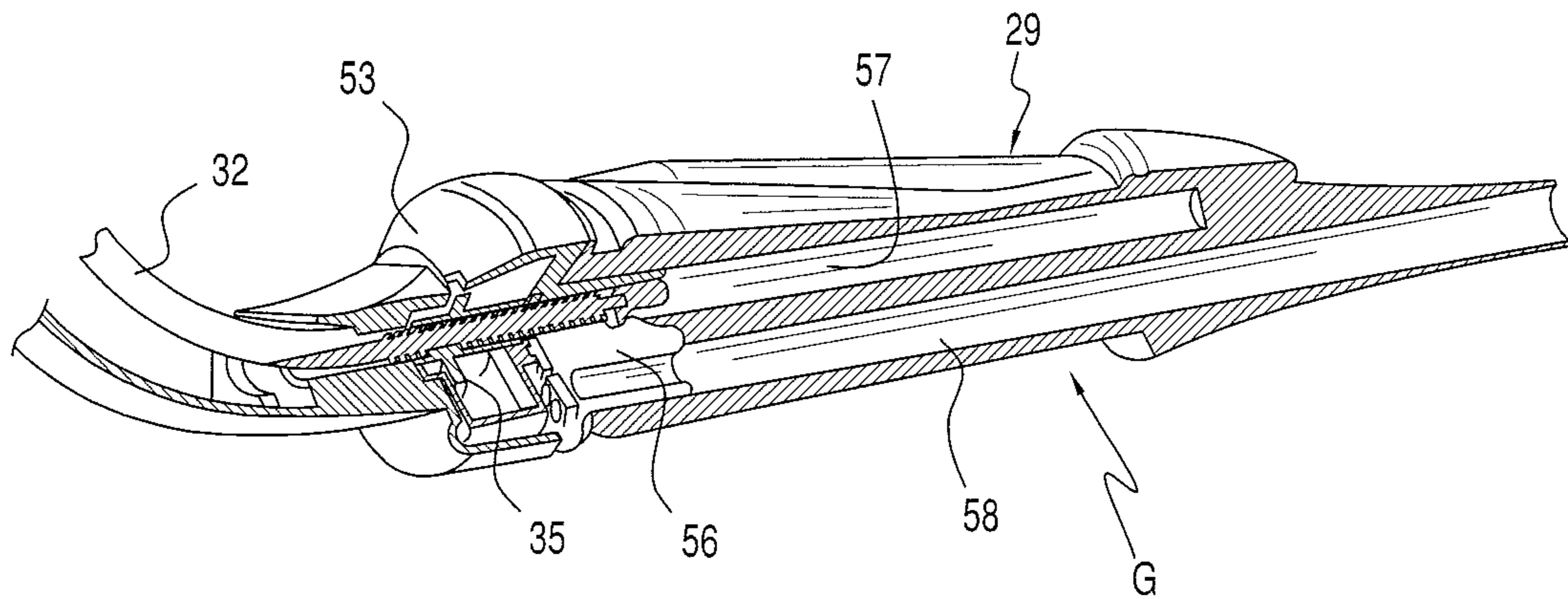

FIG. 21

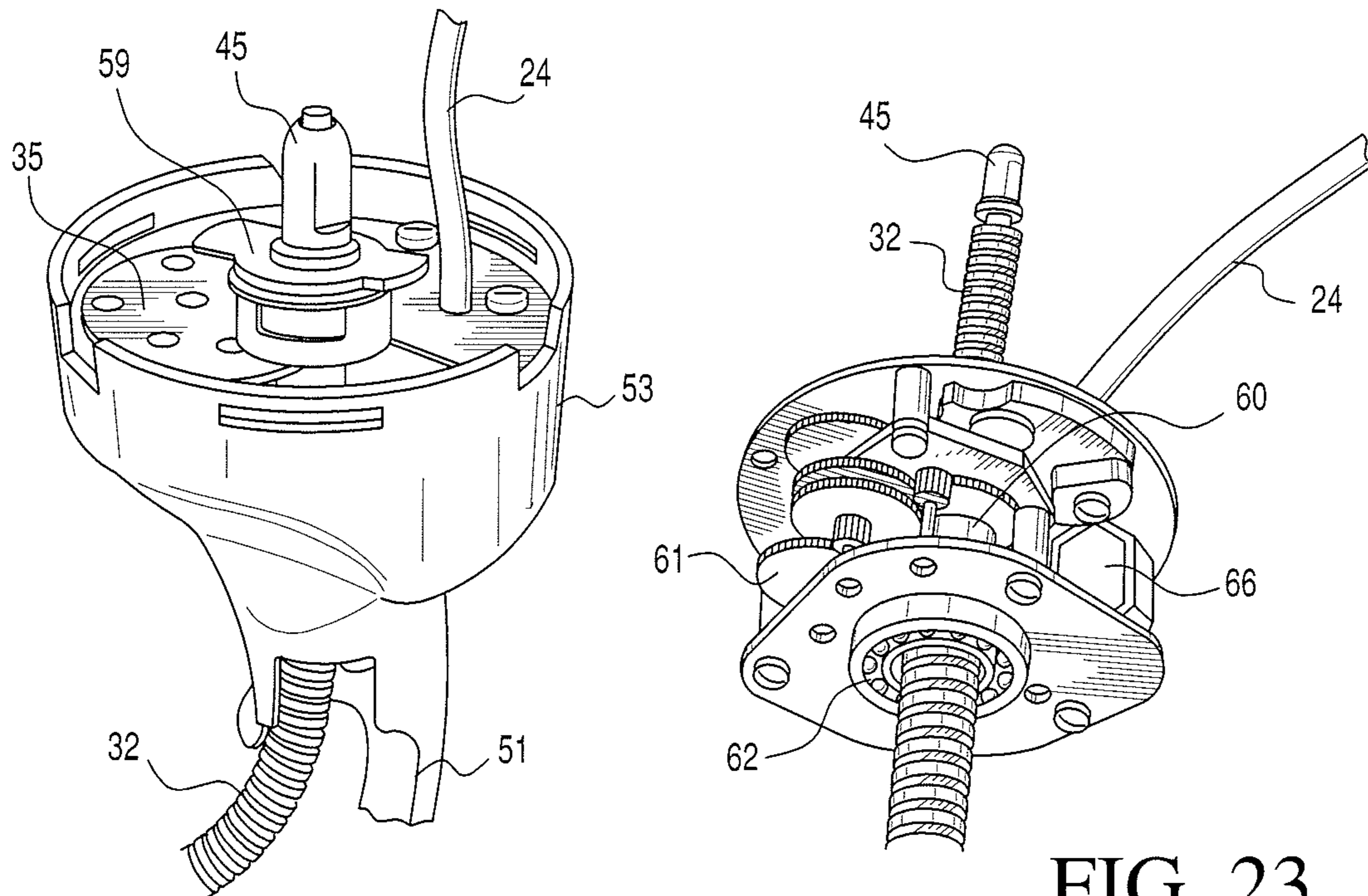

FIG. 22

FIG. 23

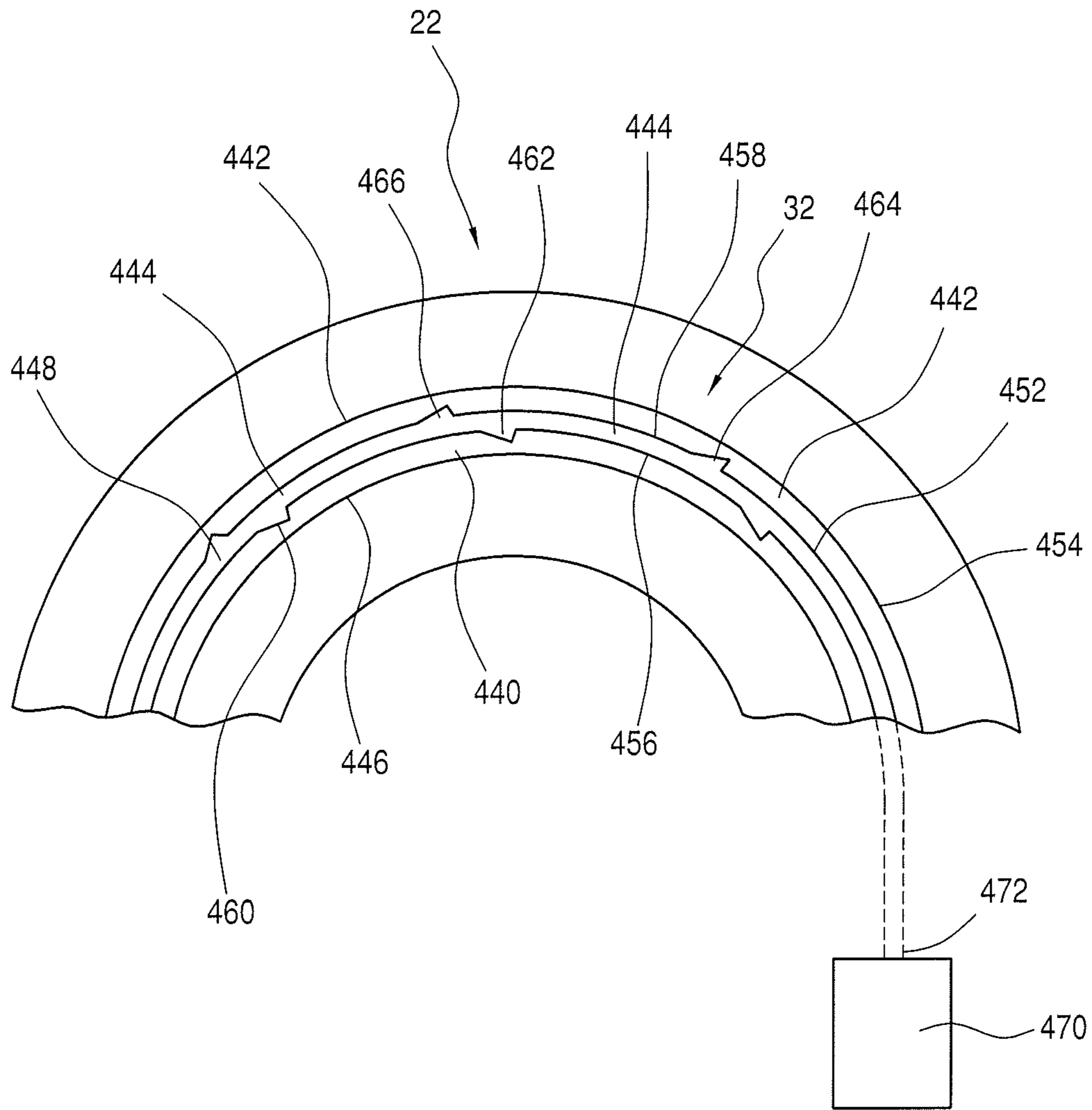

FIG. 24

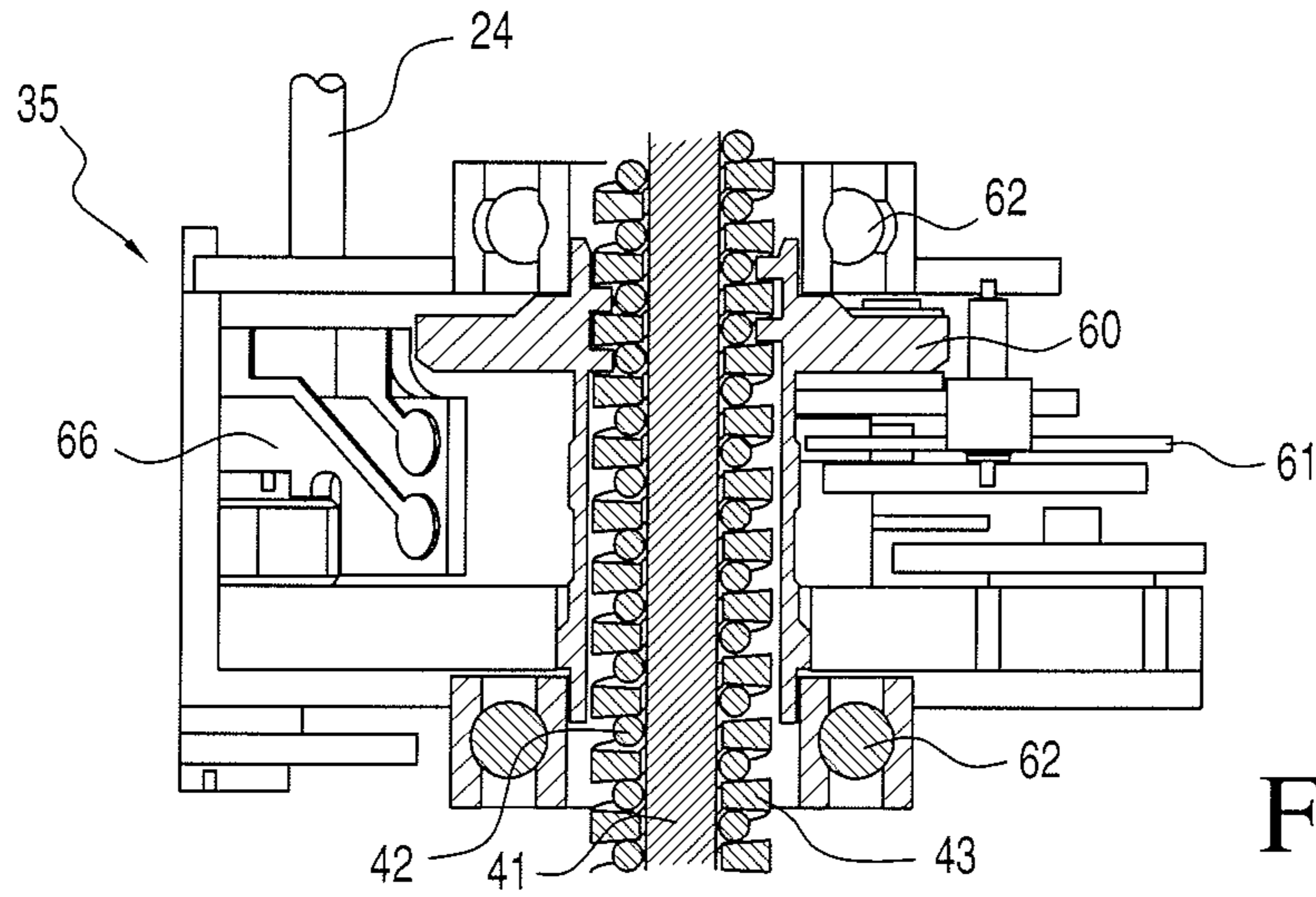

FIG. 25

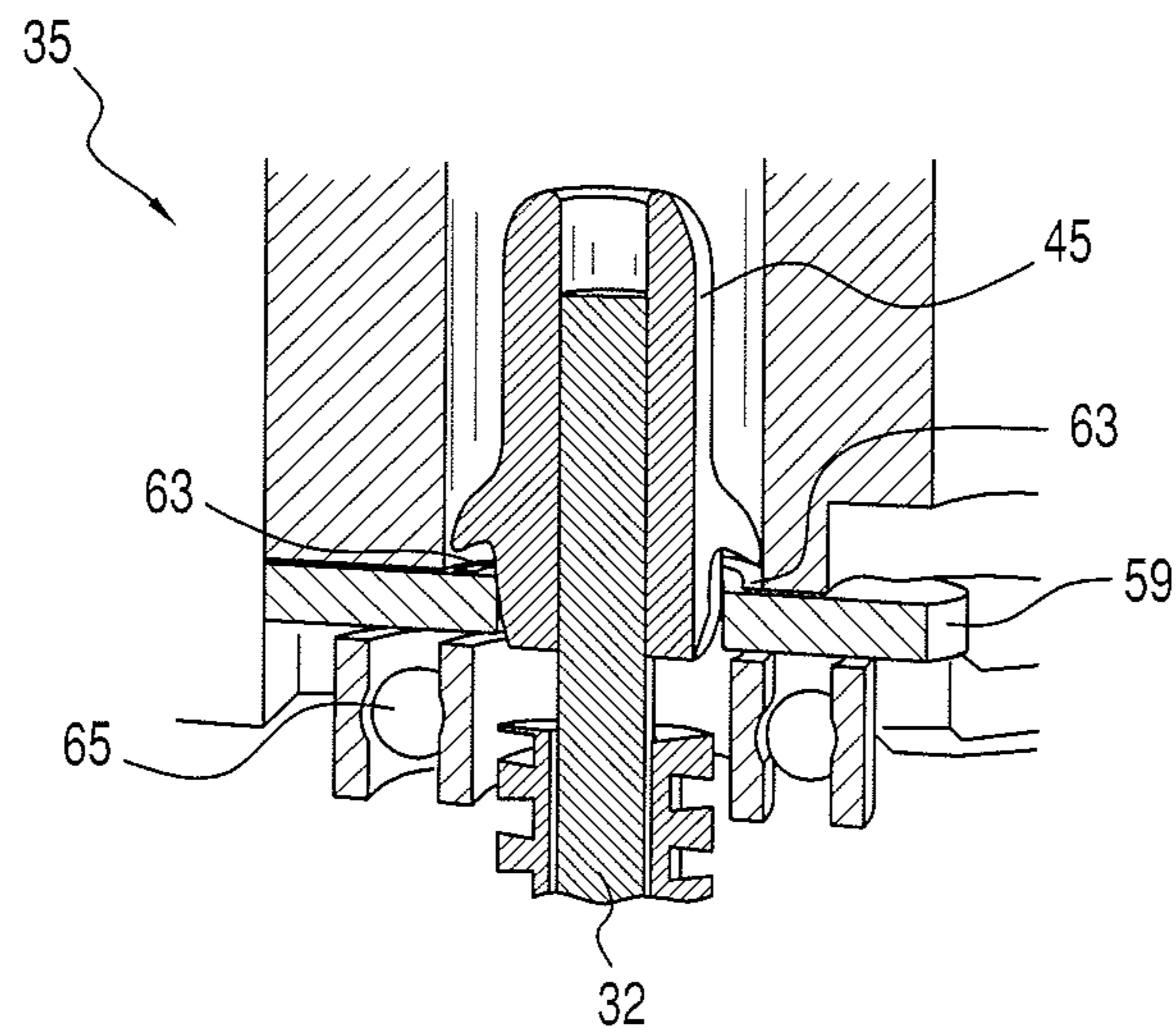

FIG. 26

FIG. 27

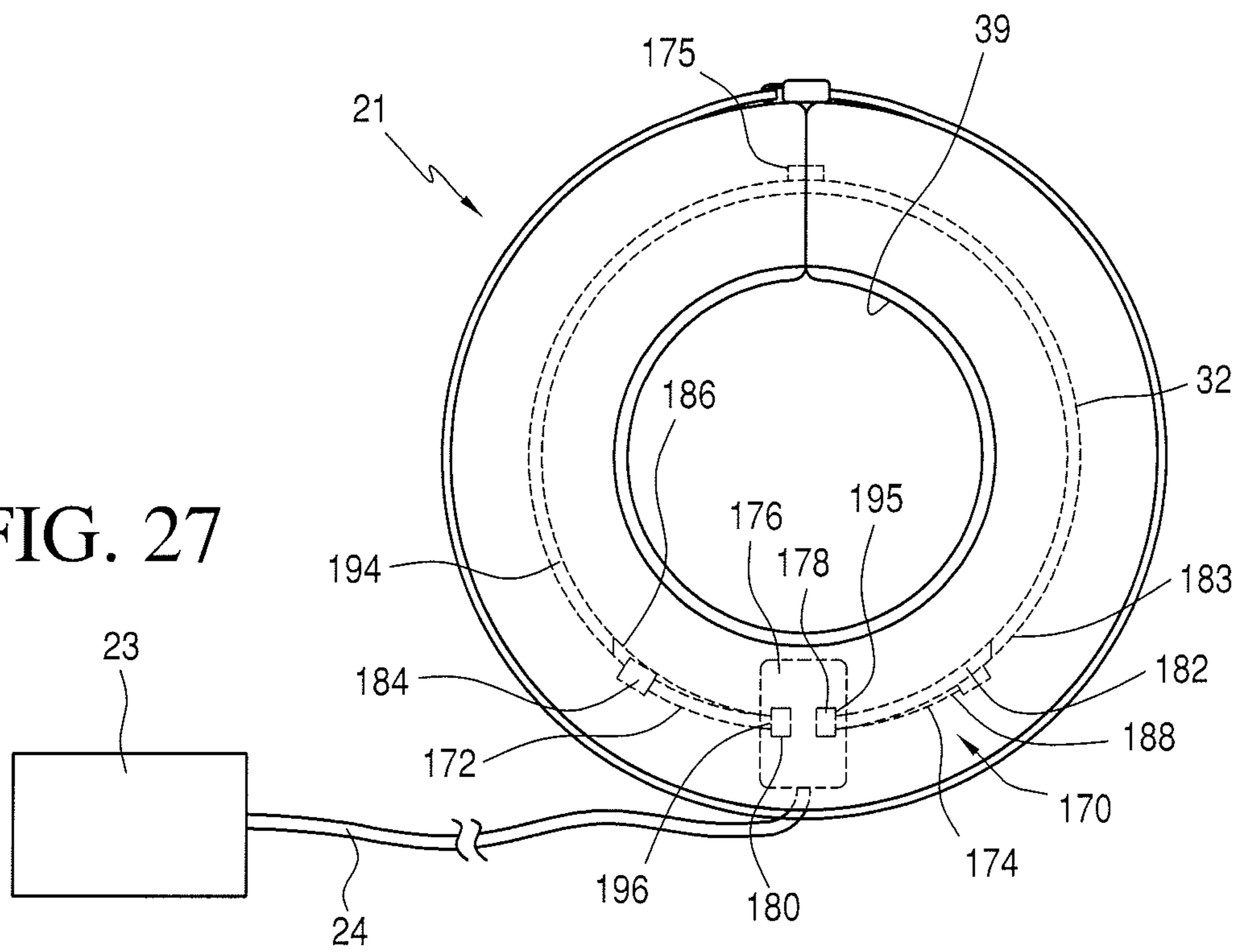

FIG. 28

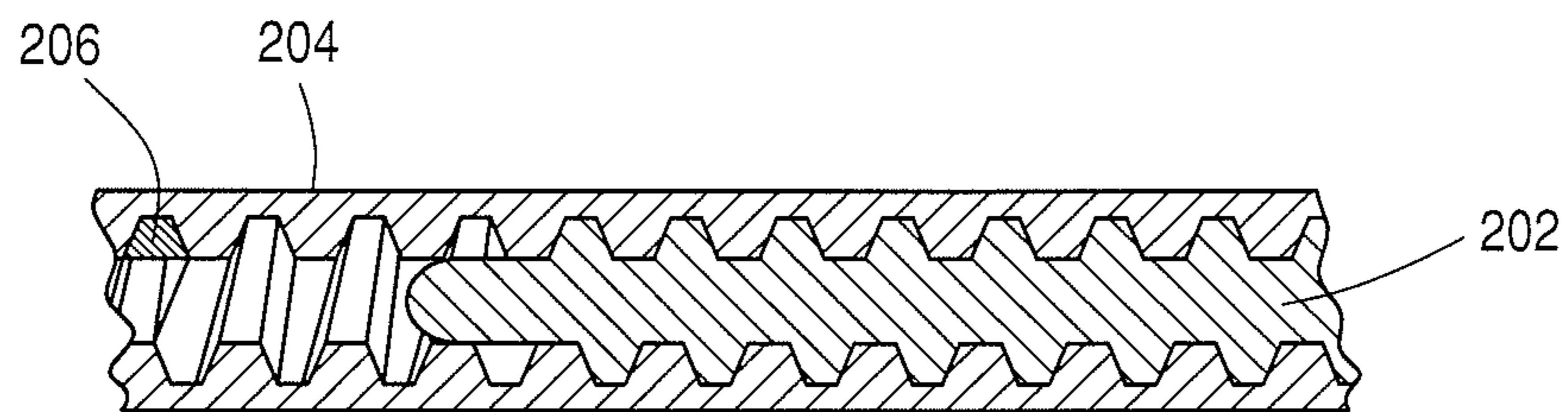
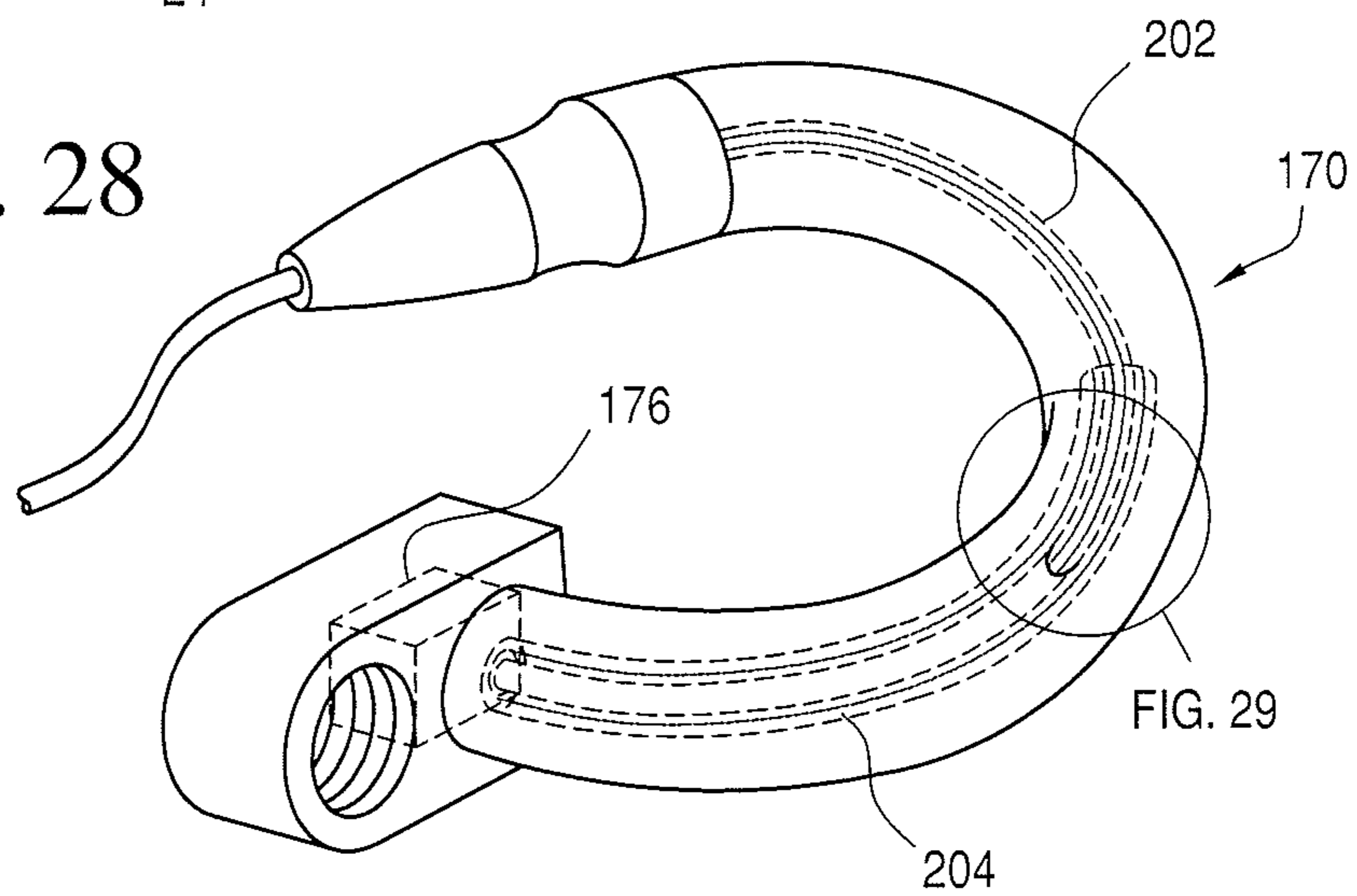

FIG. 29

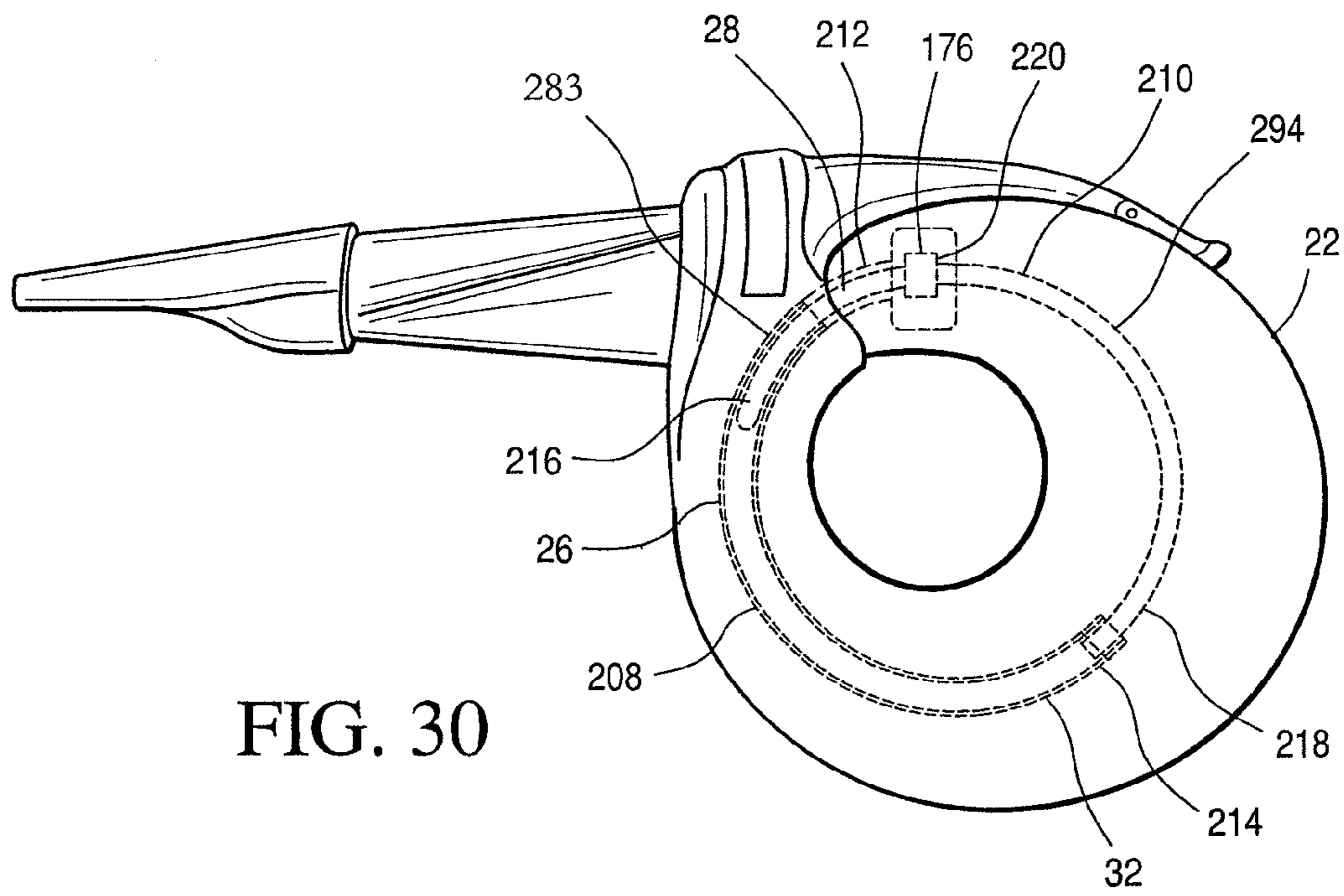

FIG. 30

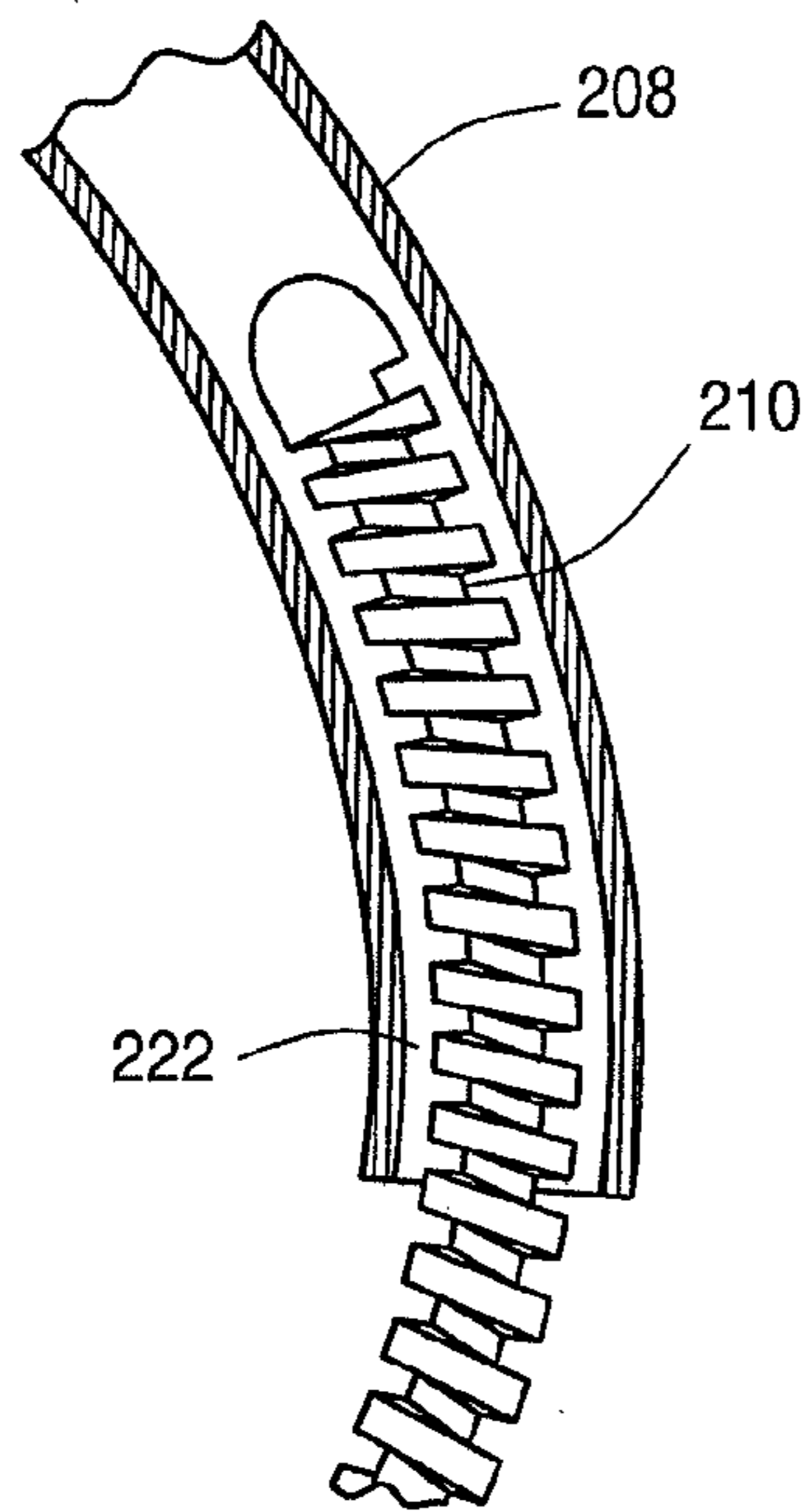

FIG. 31

FIG. 32

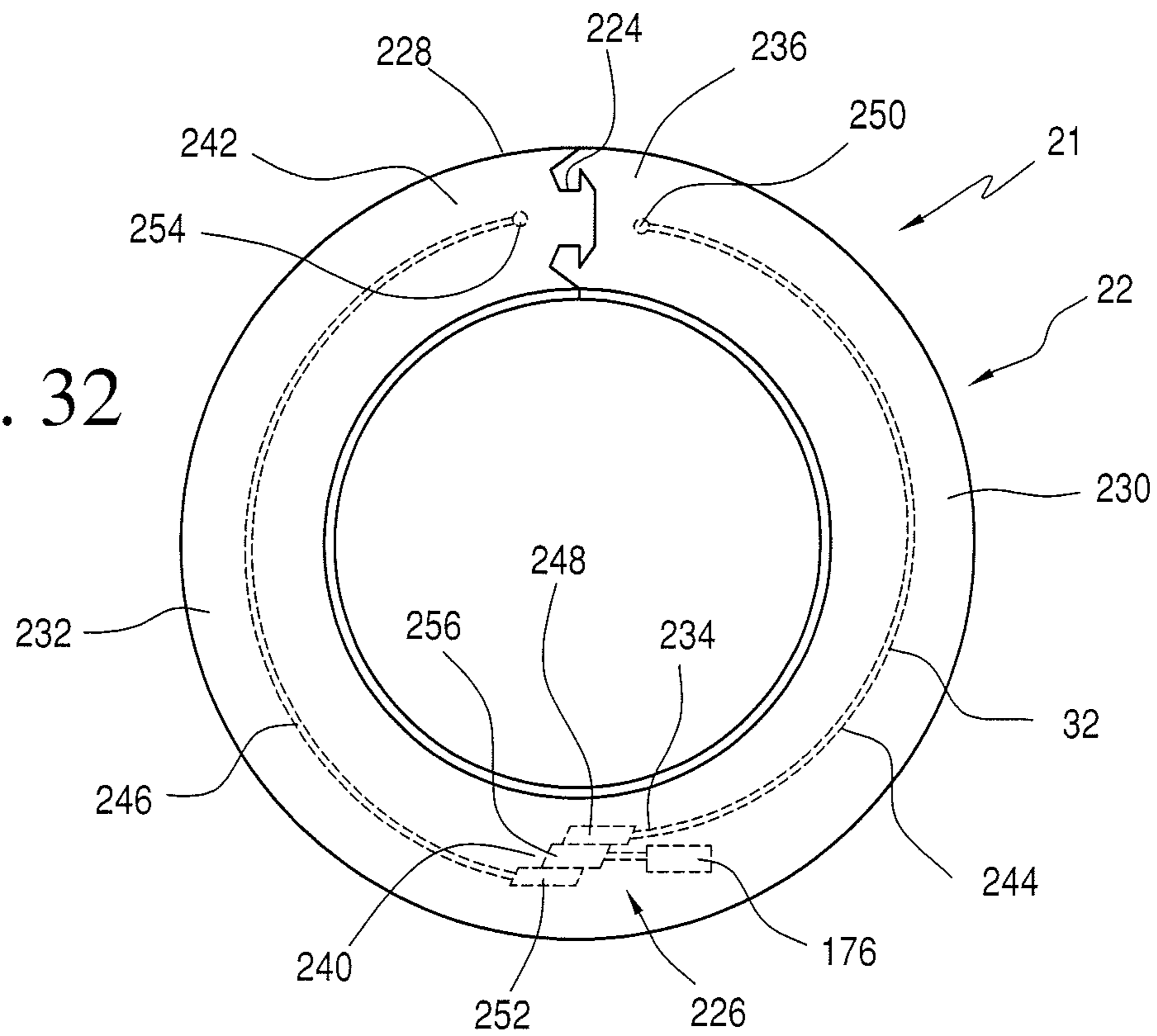

FIG. 33

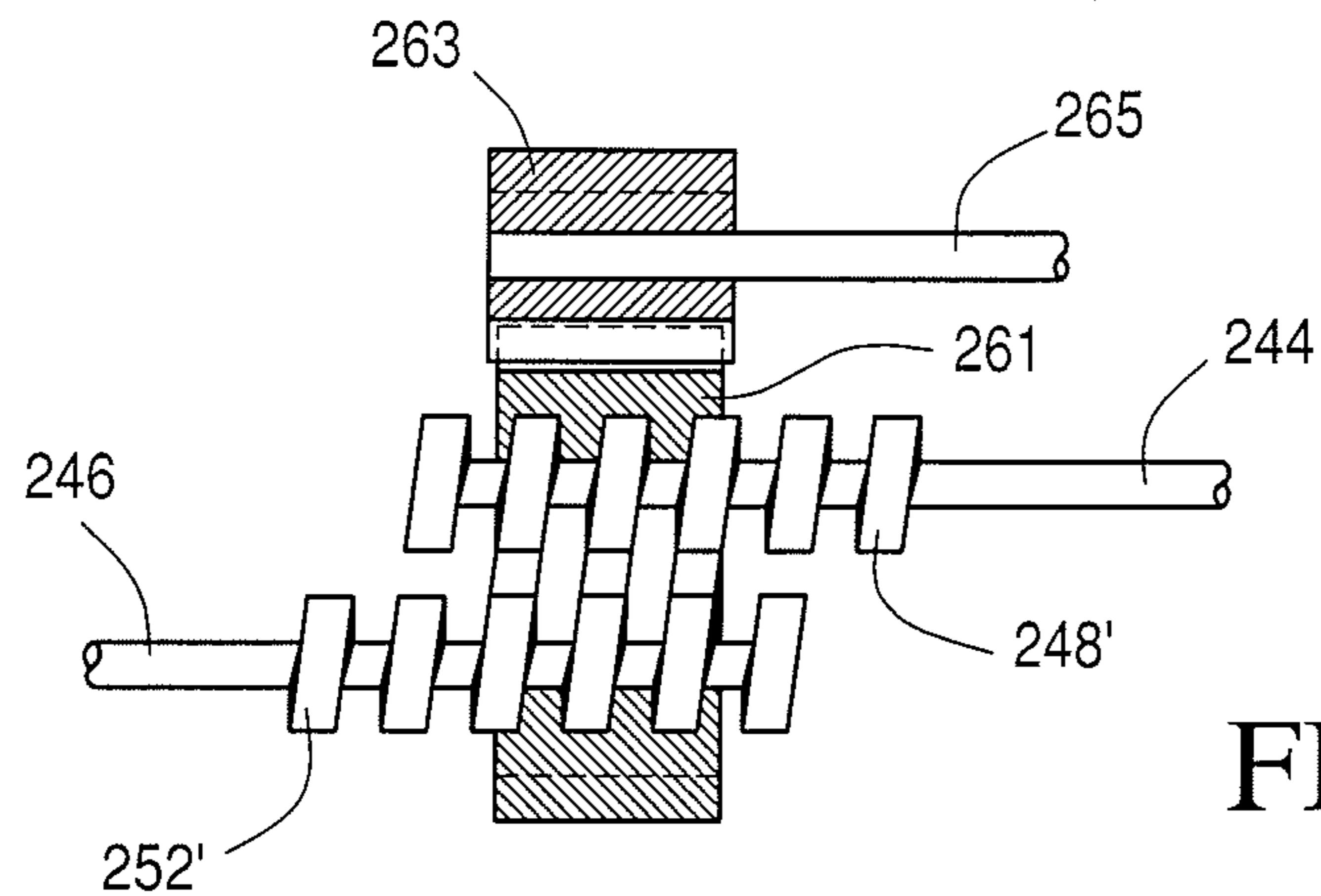
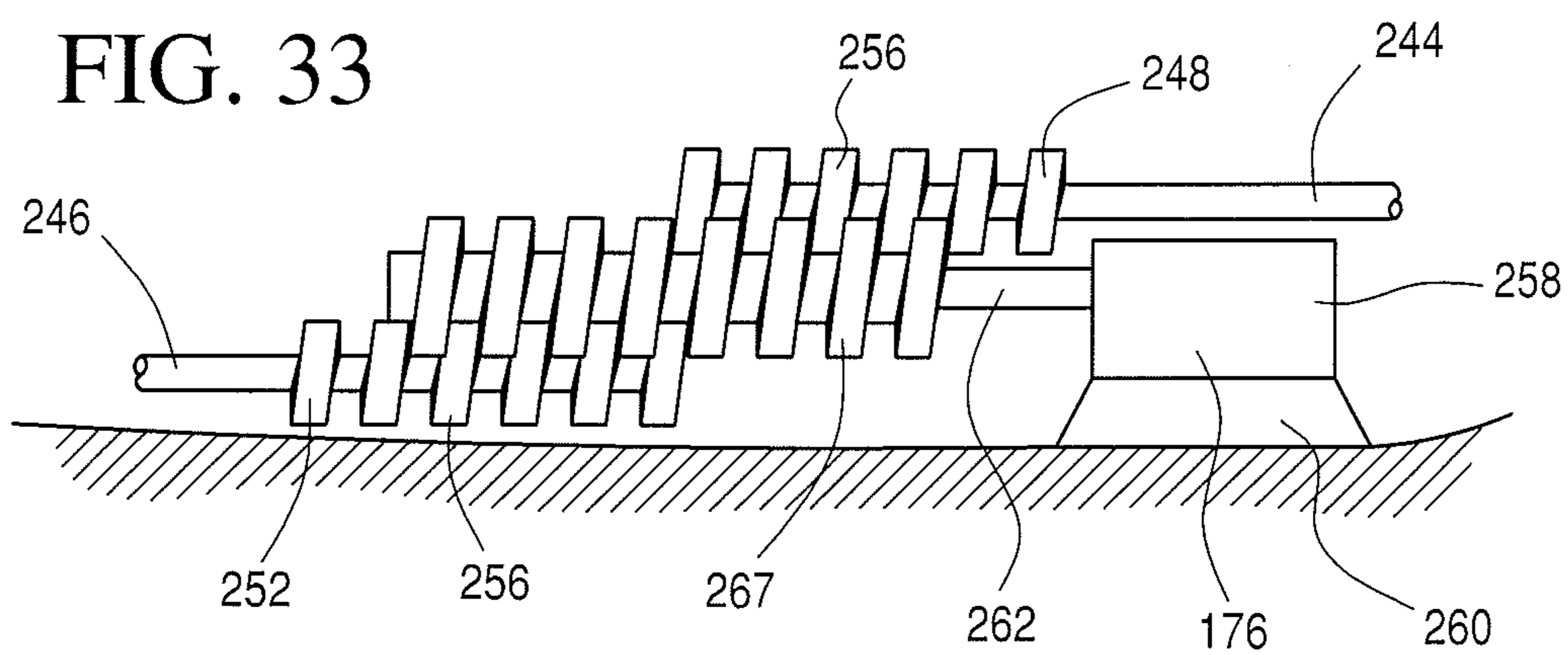

FIG. 34

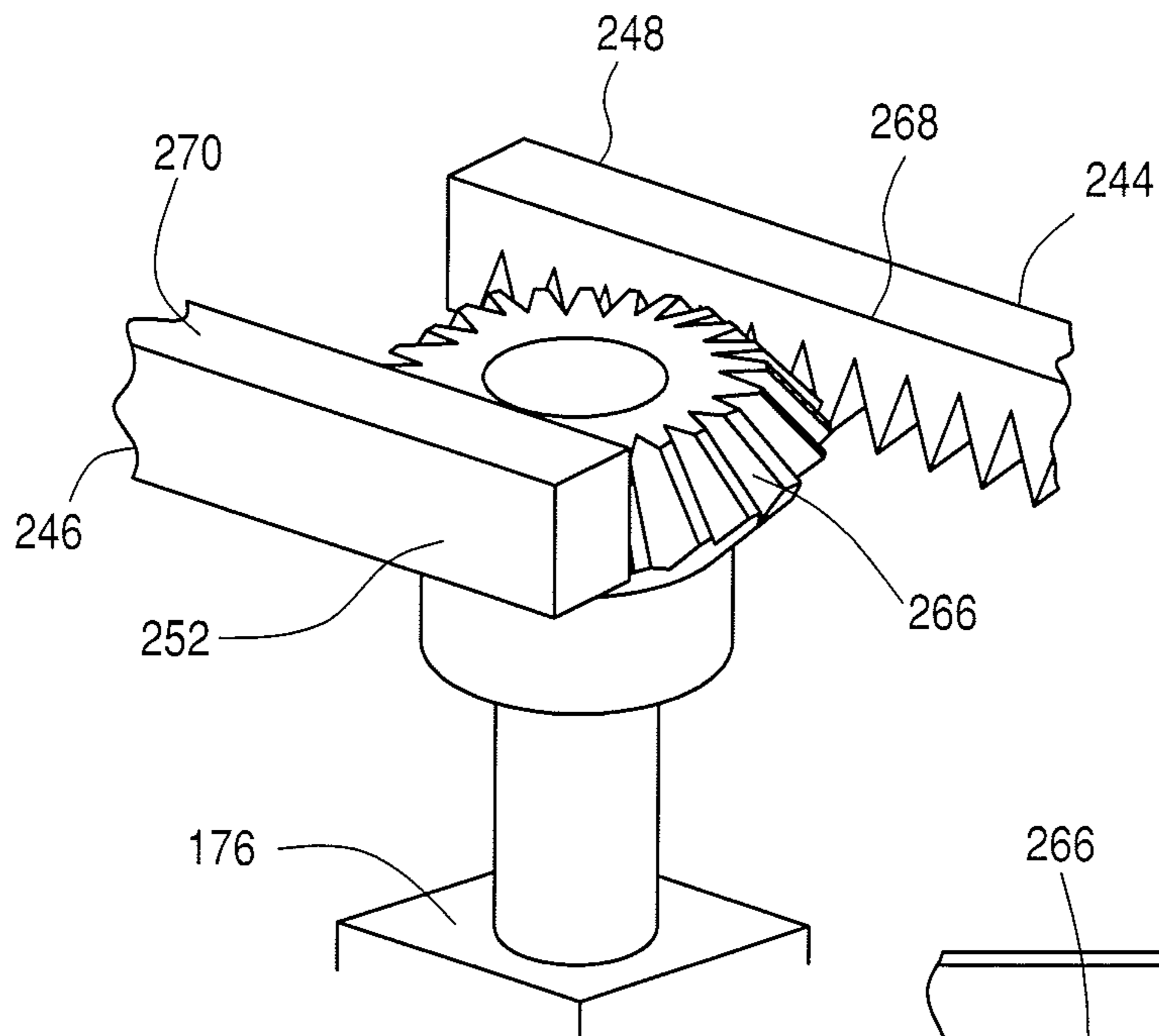

FIG. 35

FIG. 36

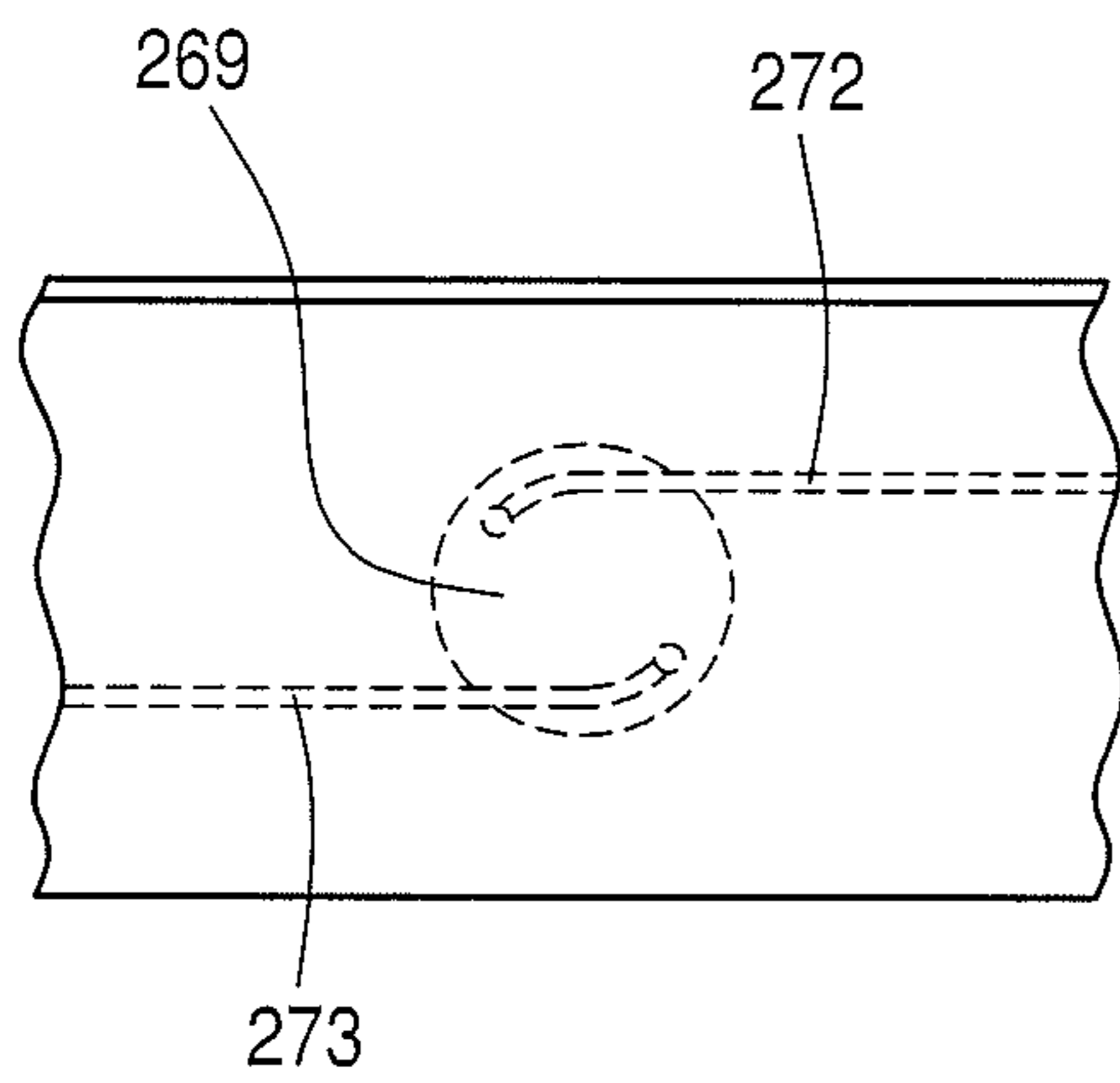
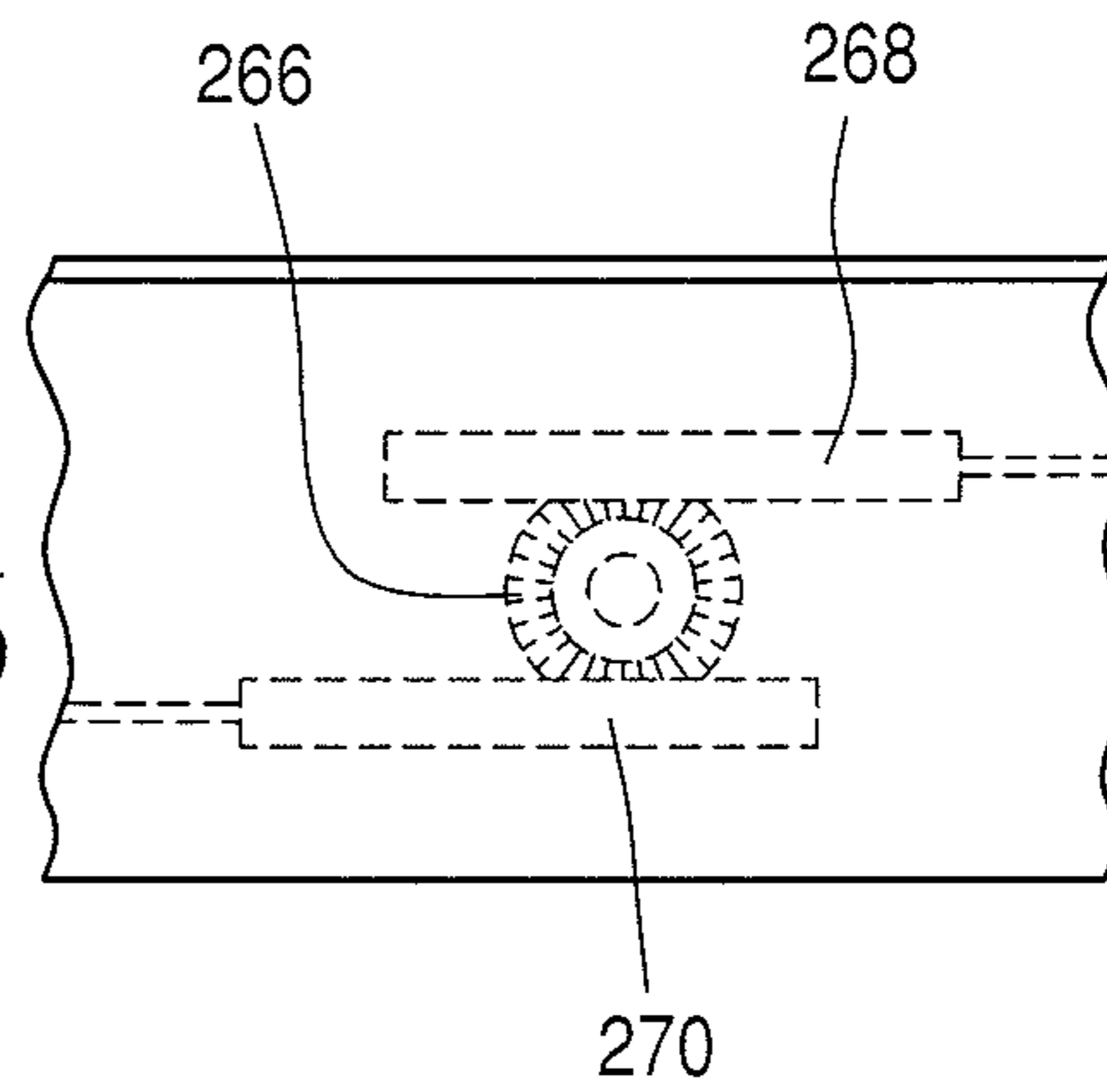

FIG. 37

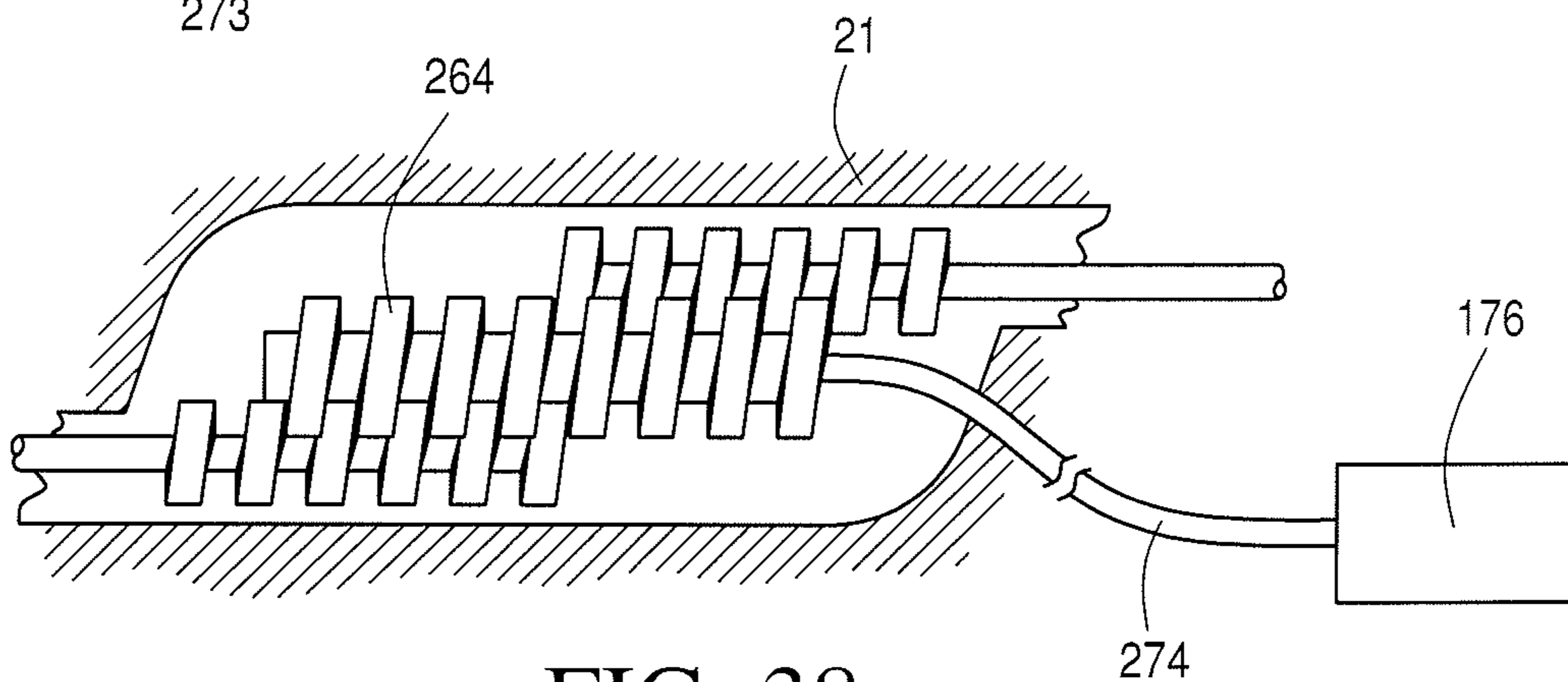

FIG. 38

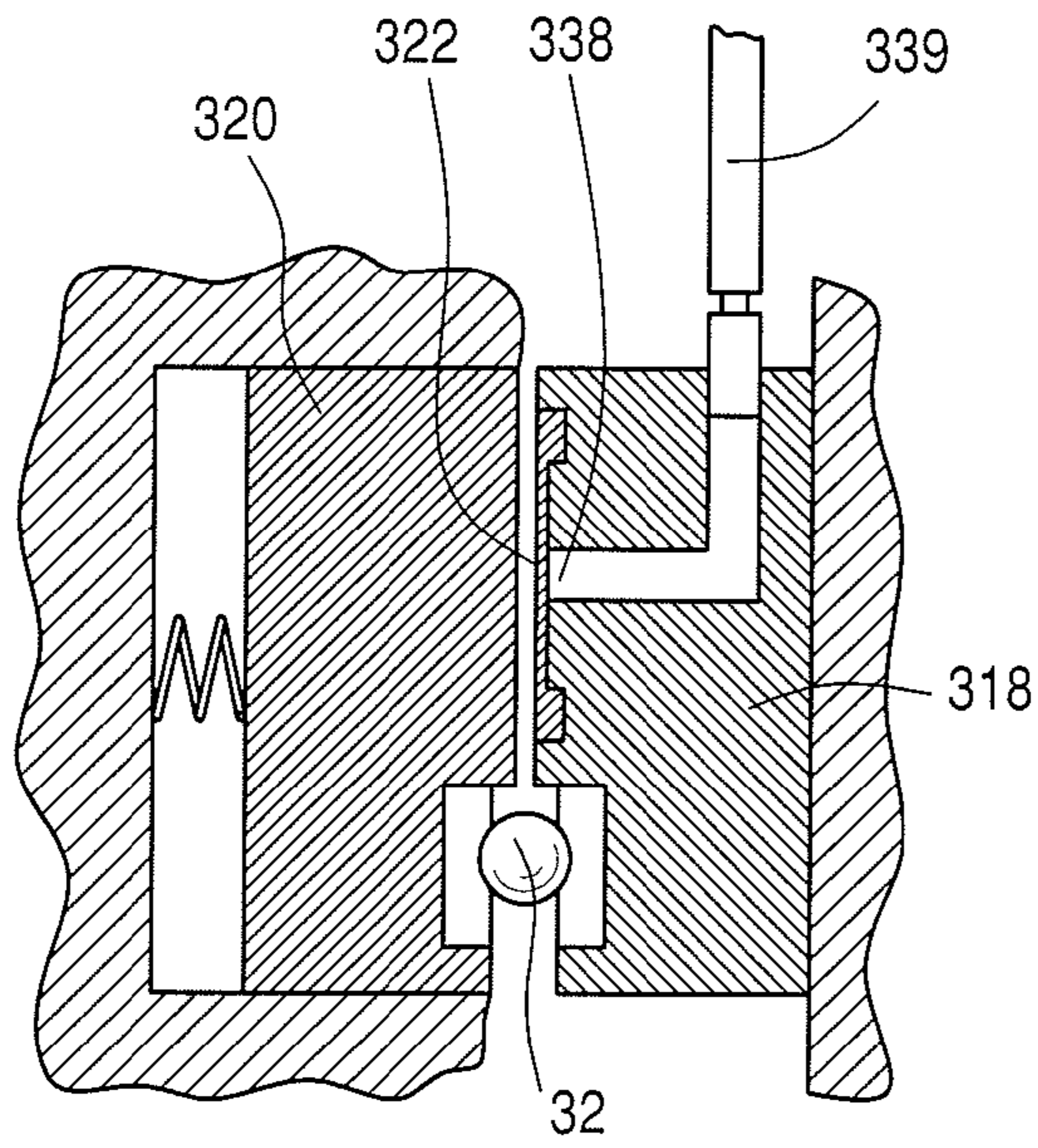

FIG. 42

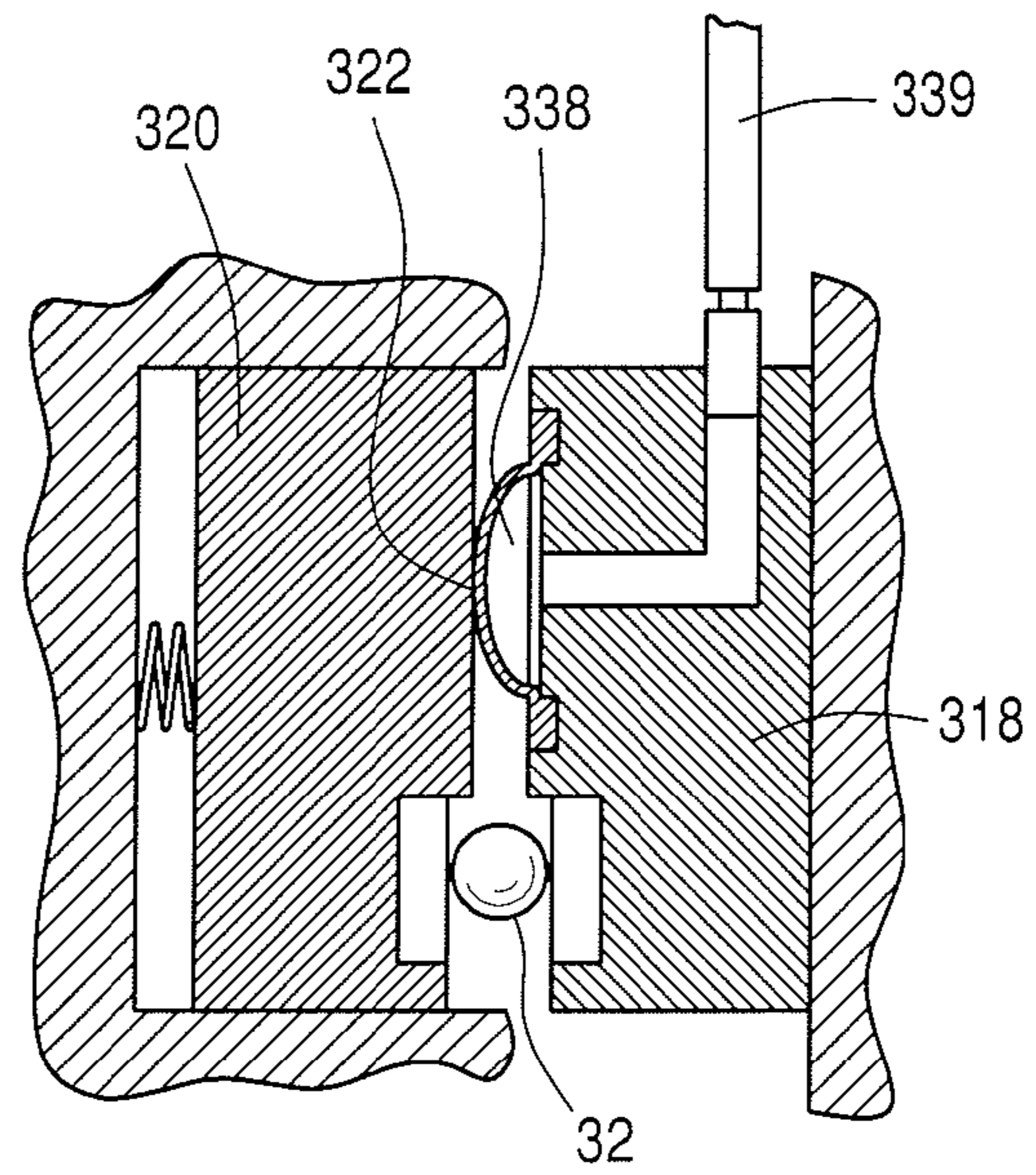

FIG. 43

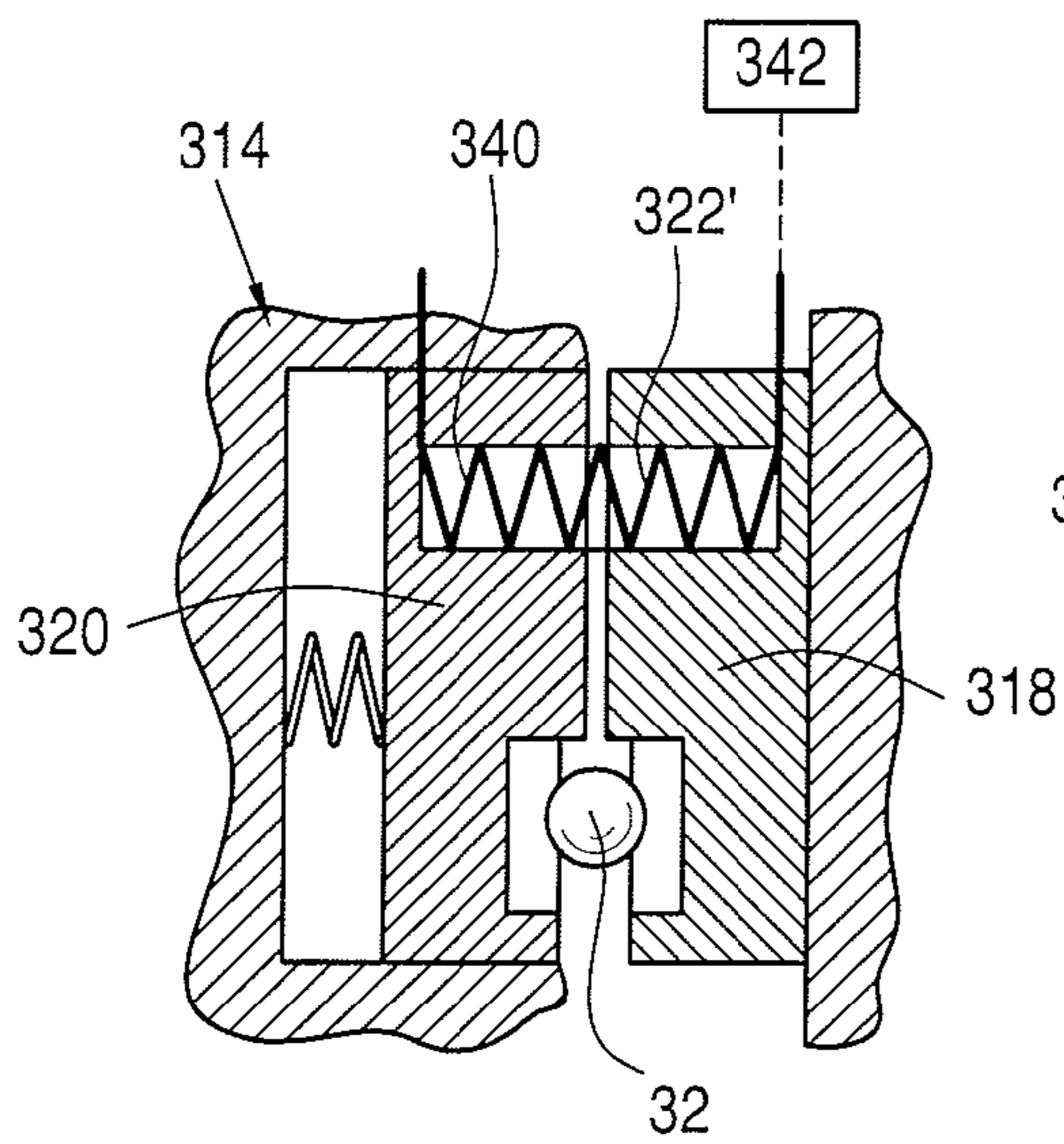

FIG. 44

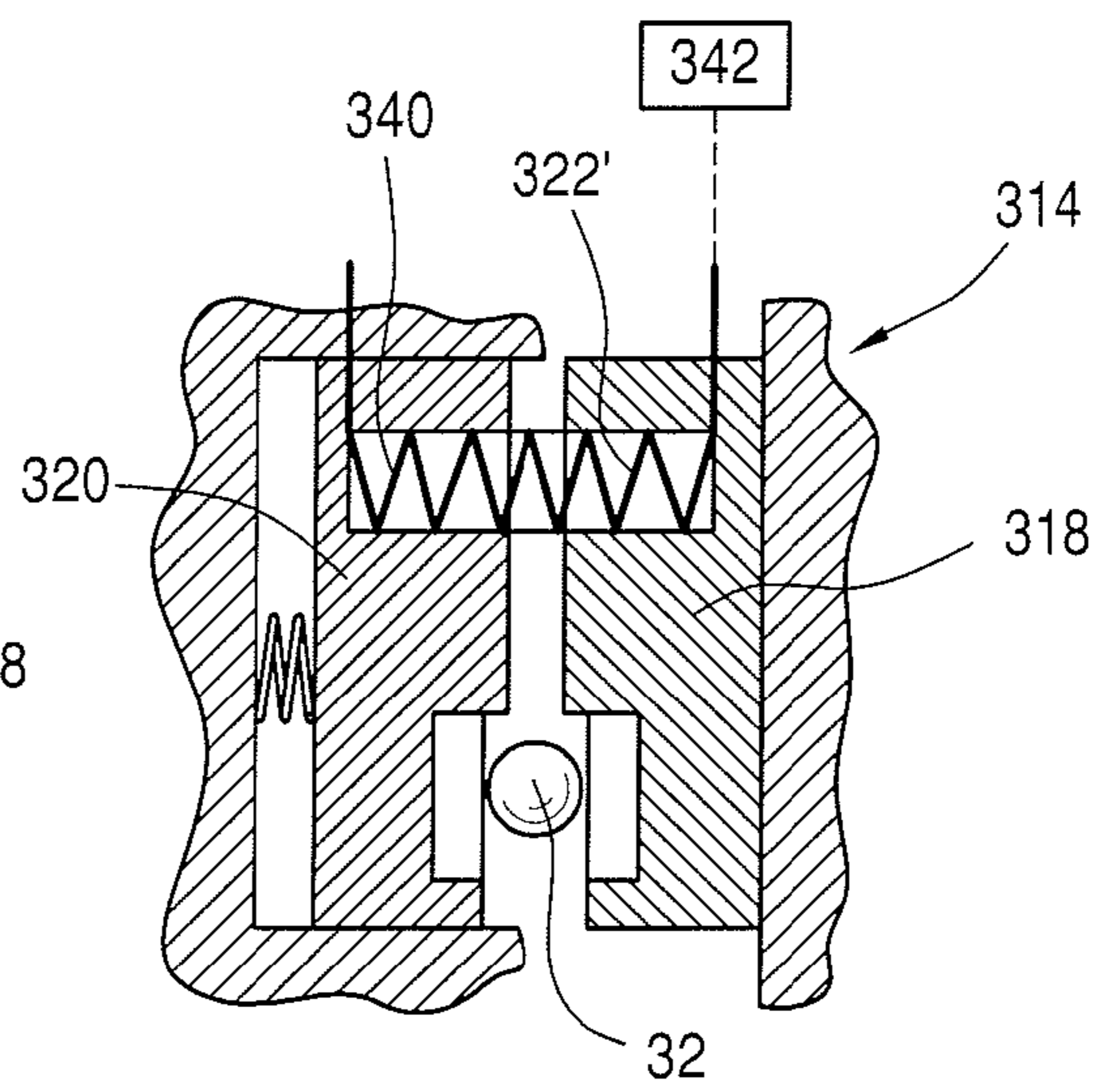

FIG. 45

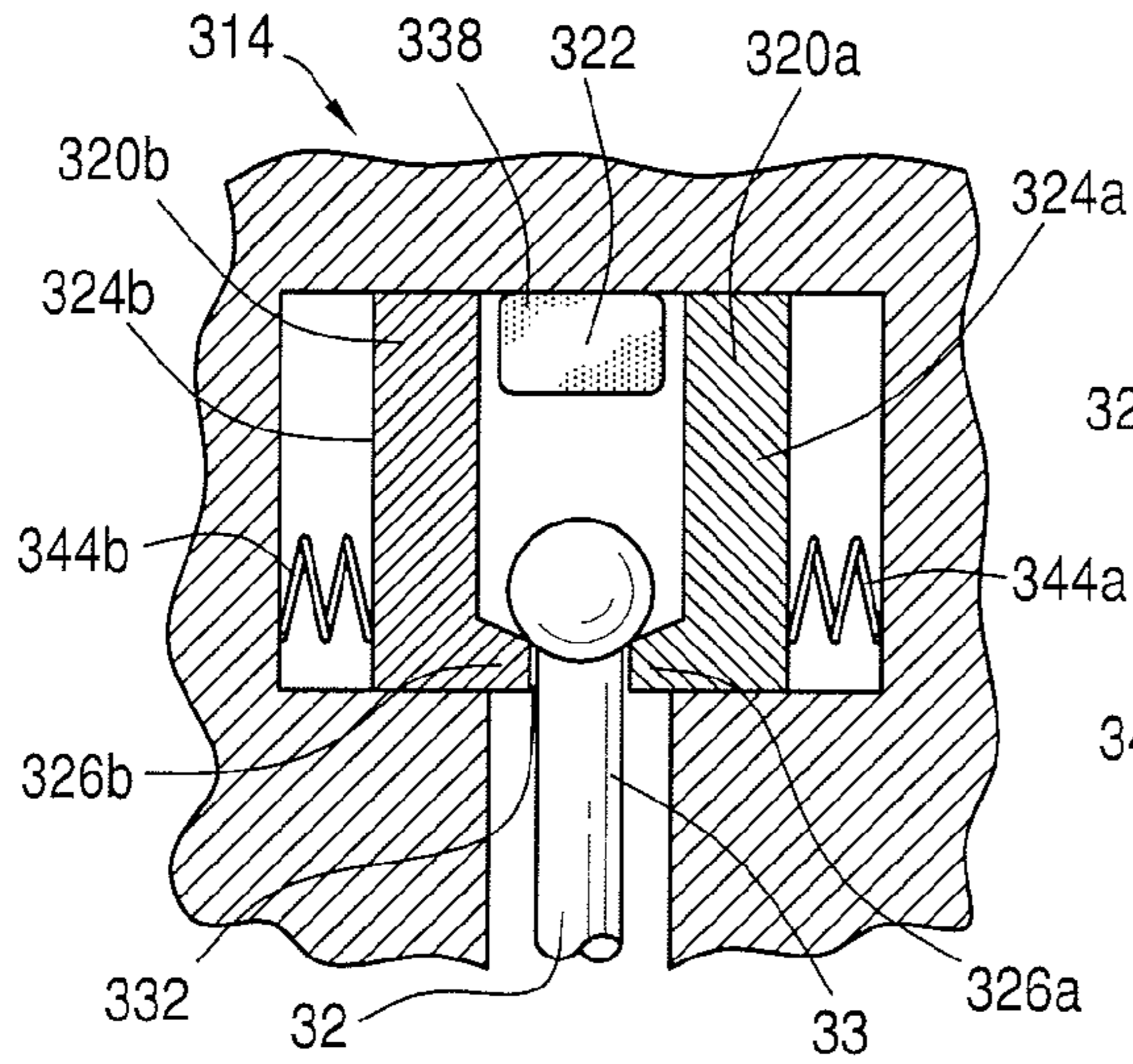

FIG. 46

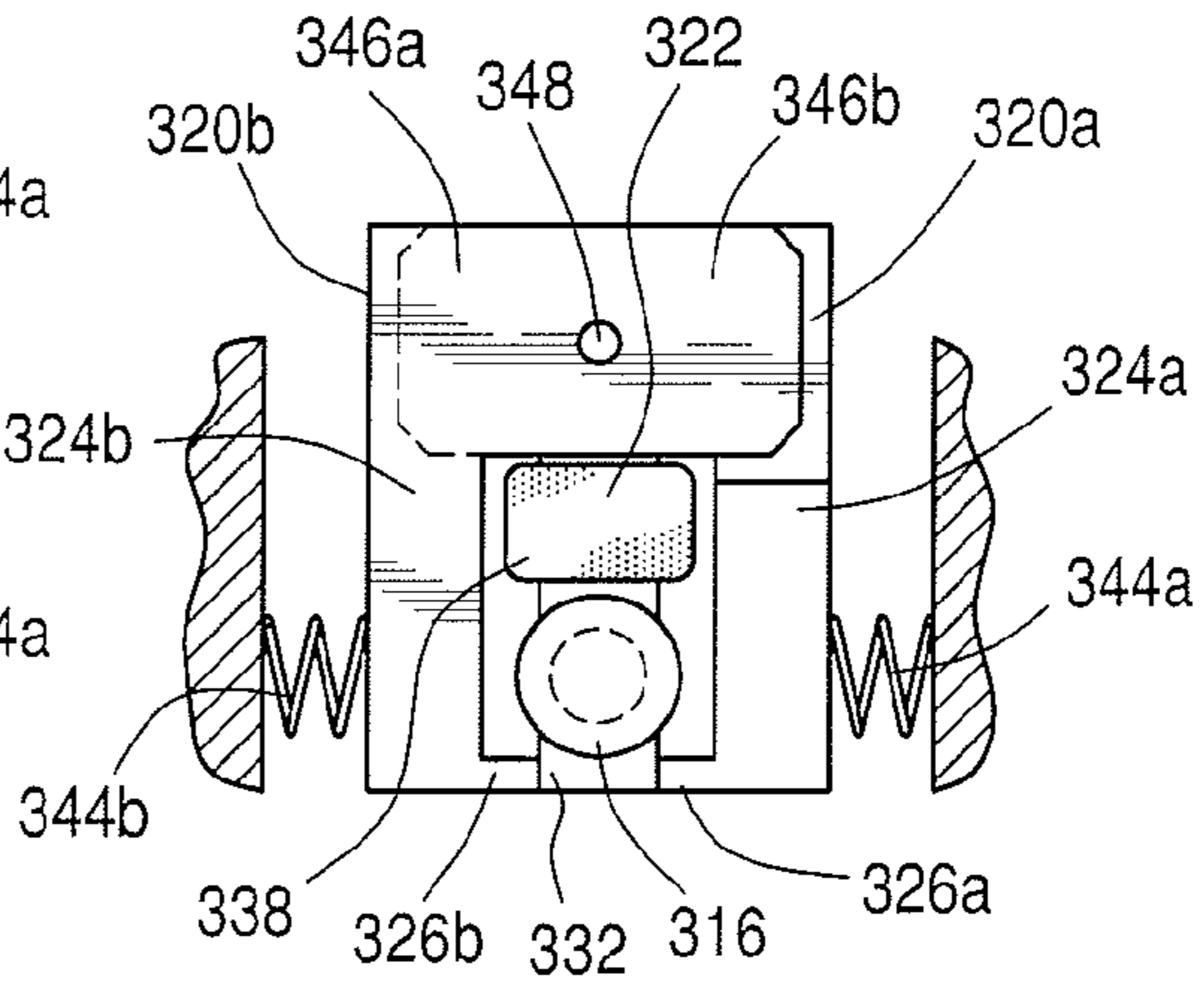

FIG. 47

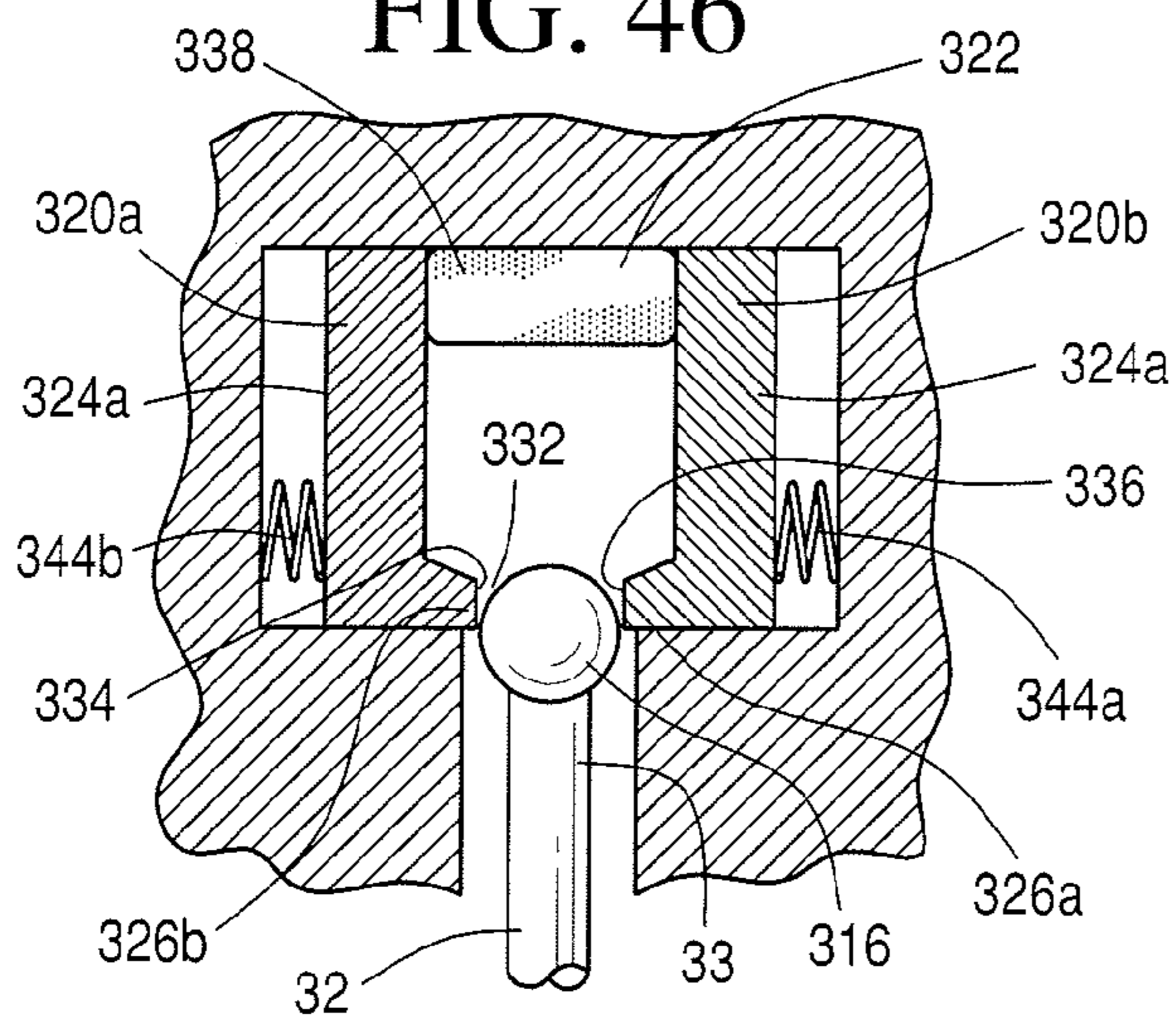

FIG. 48

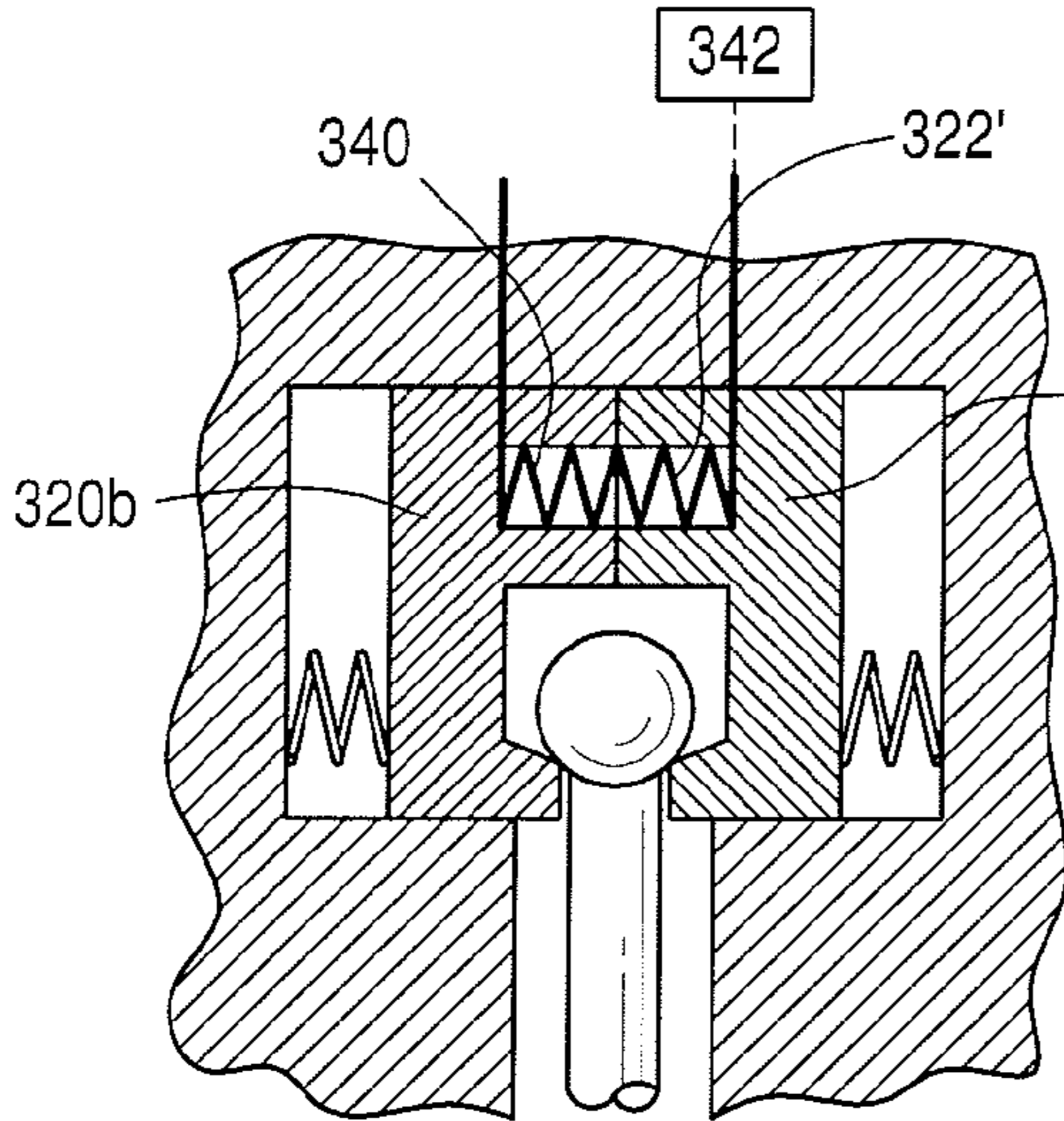

FIG. 49

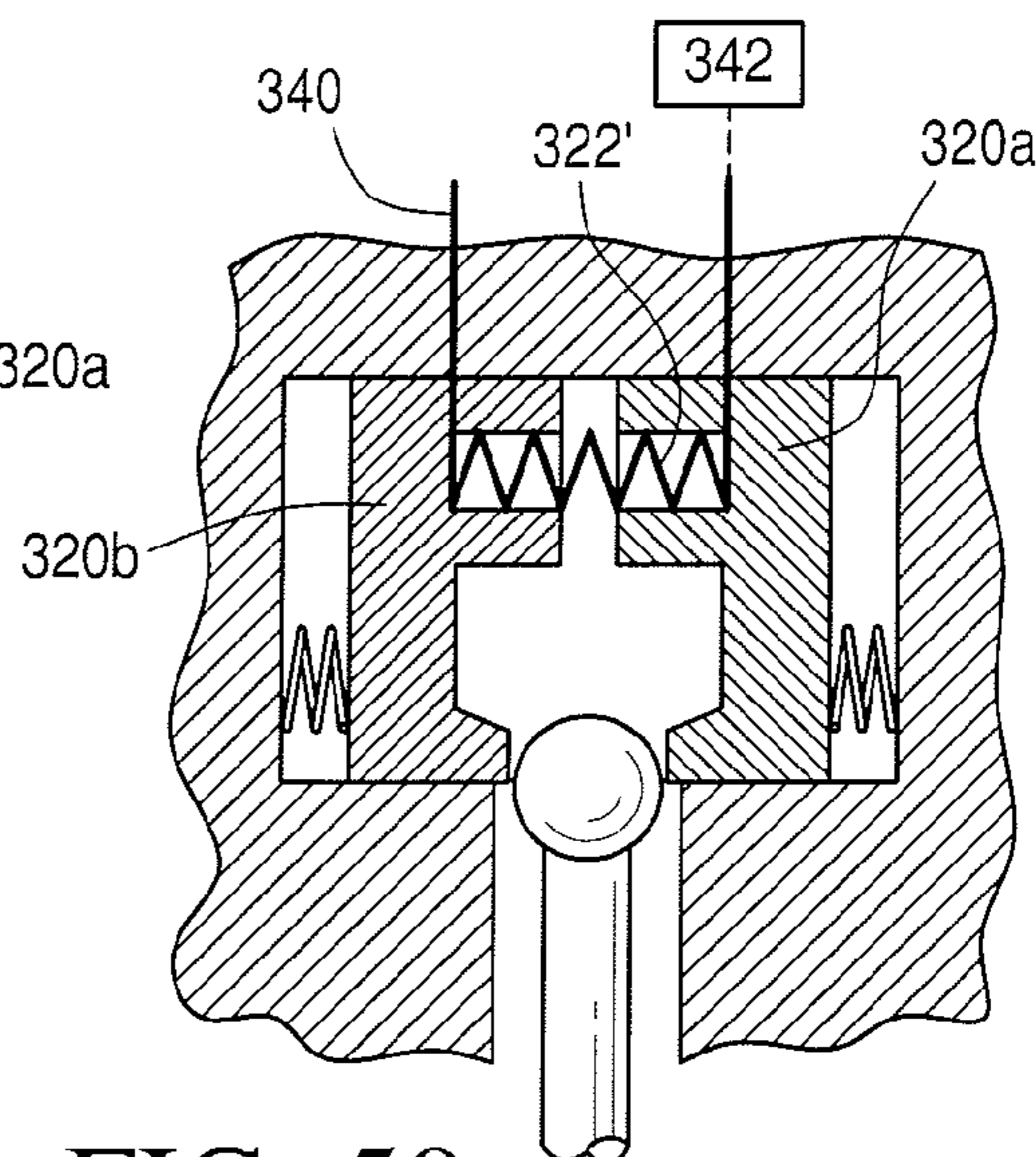

FIG. 50

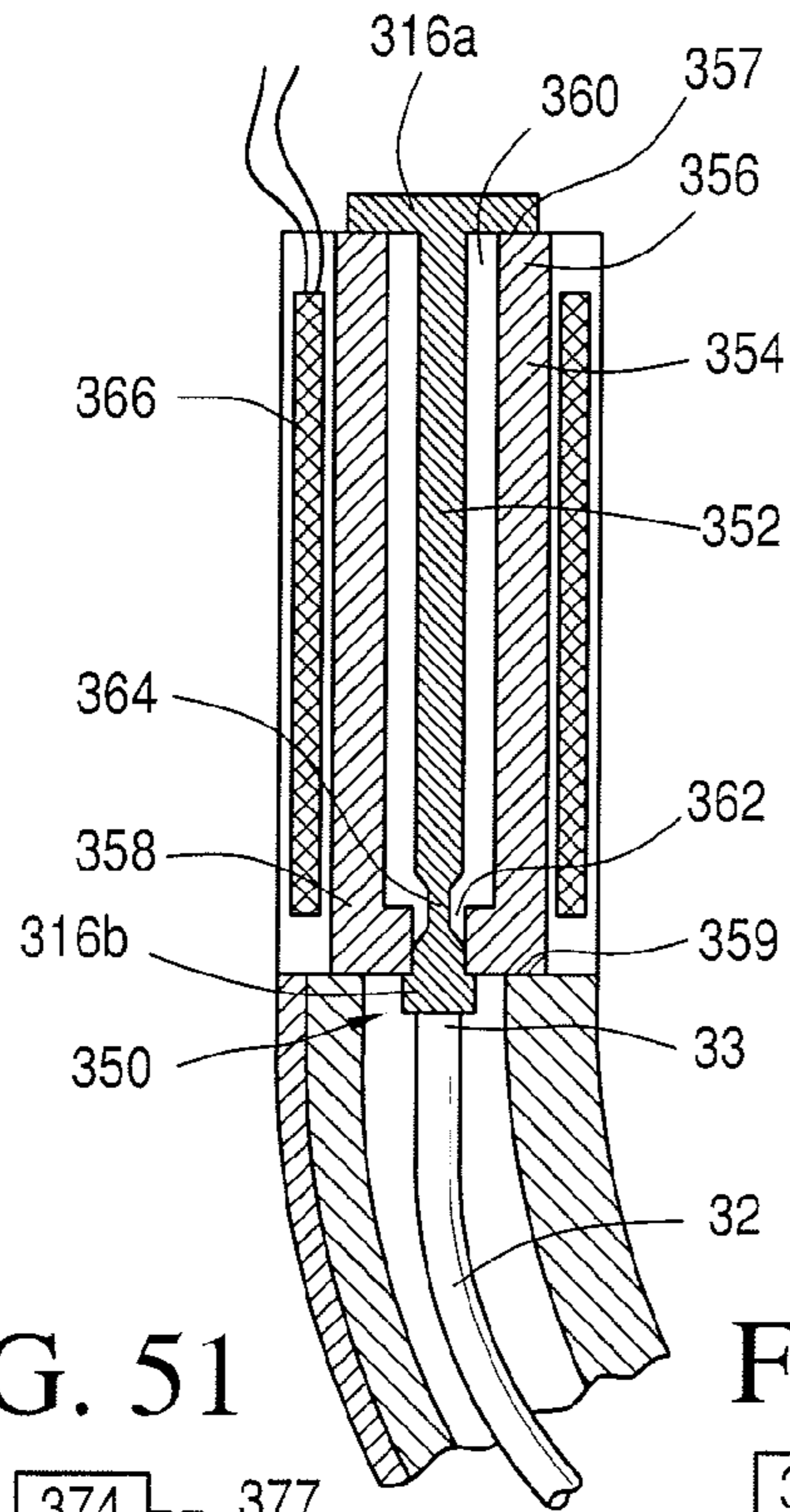

FIG. 51

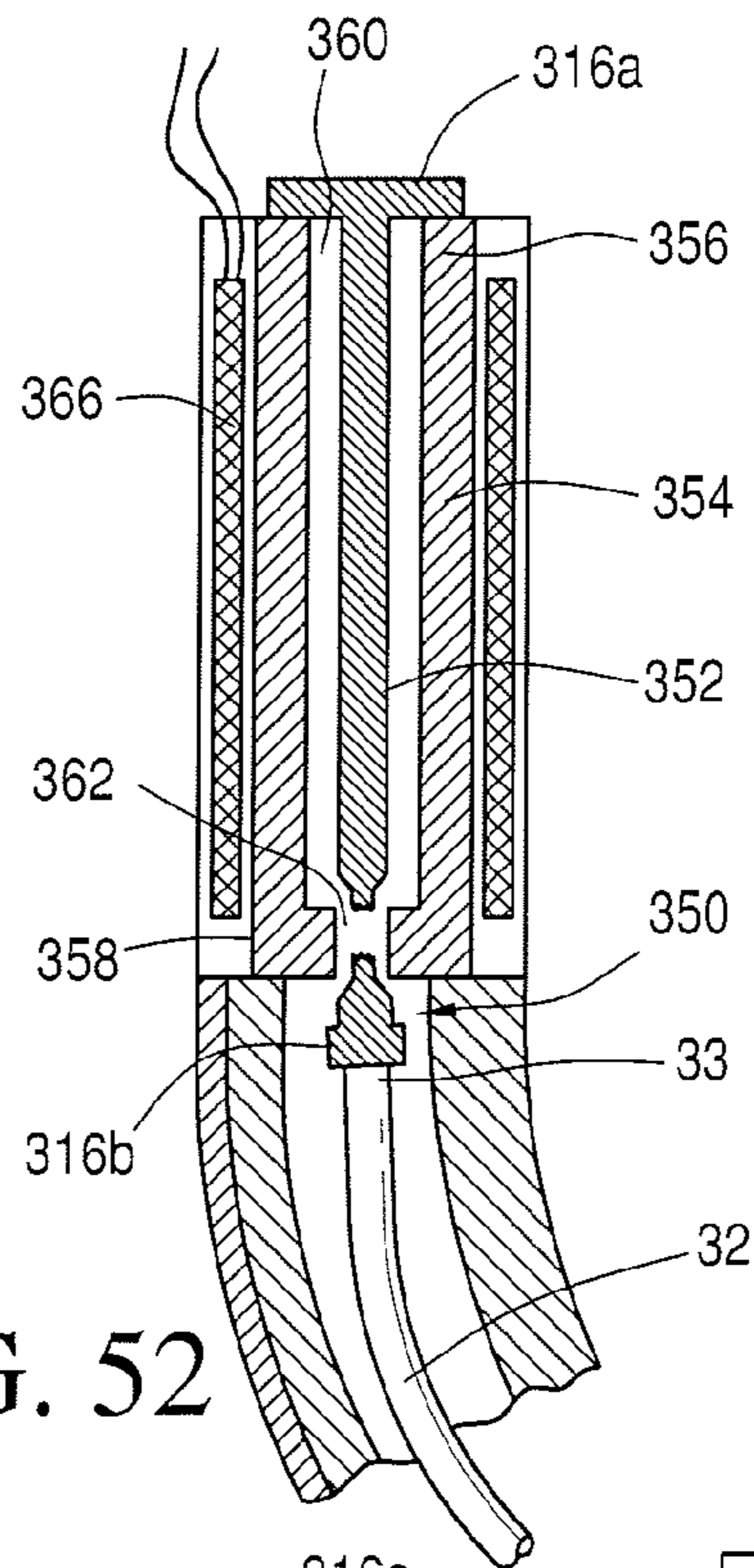

FIG. 52

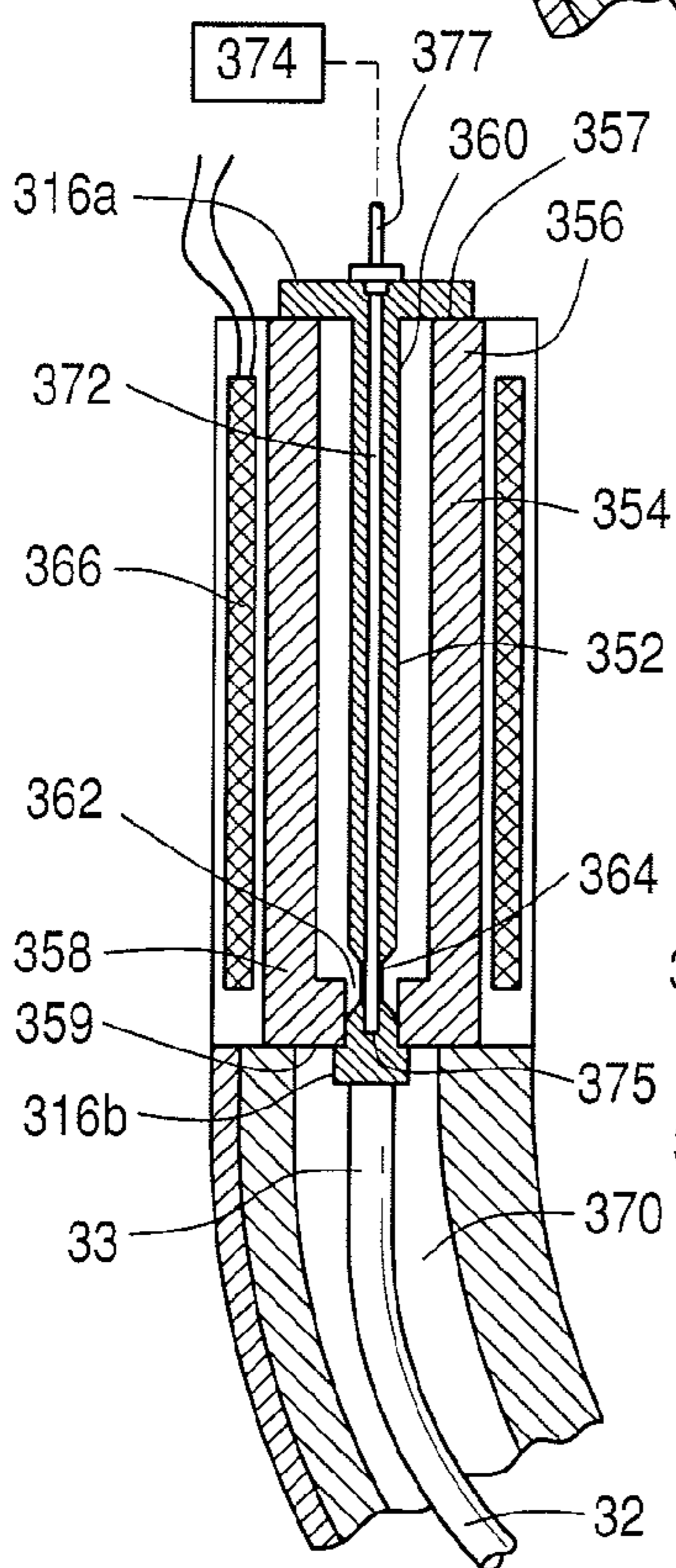

FIG. 53

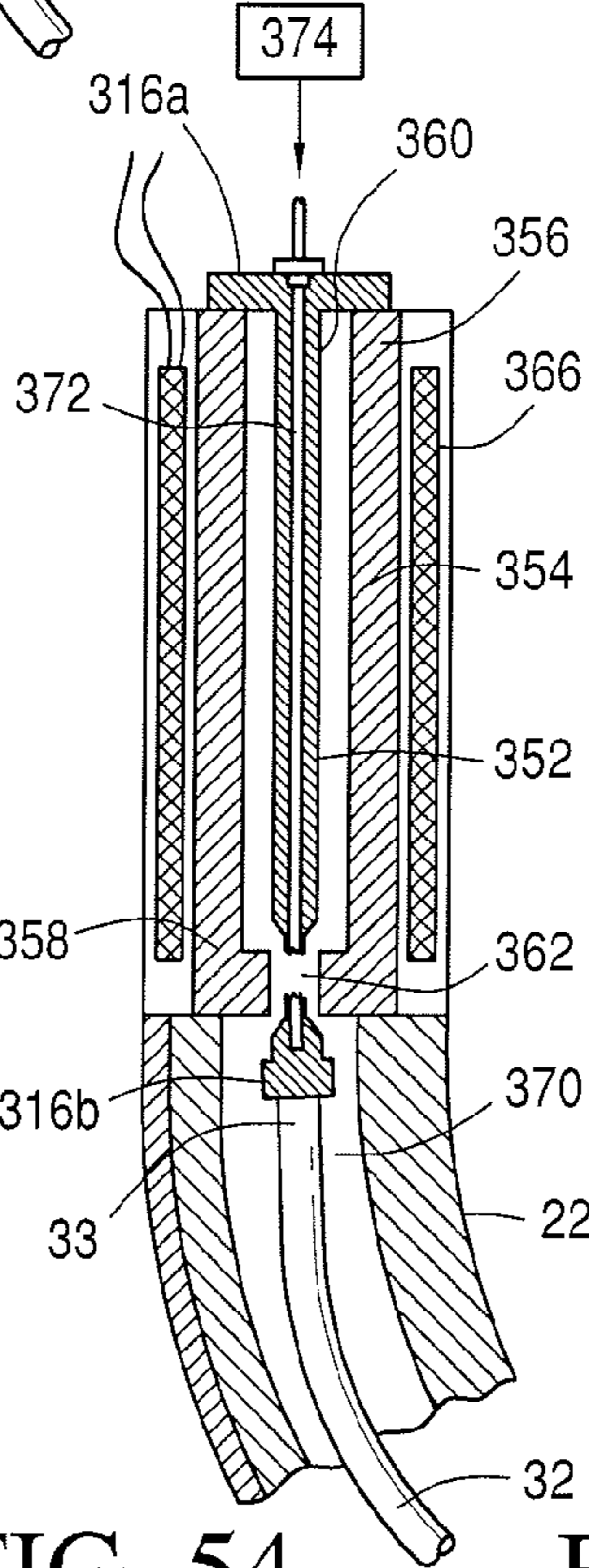

FIG. 54

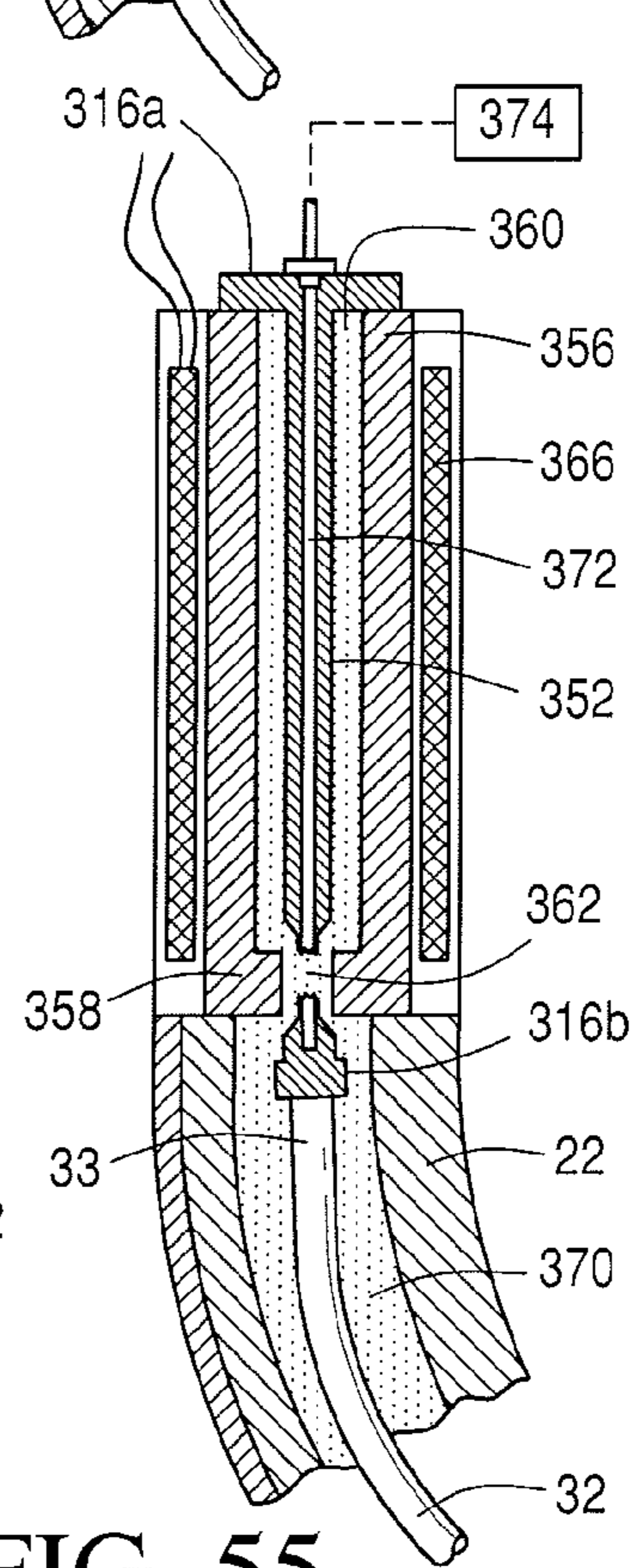

FIG. 55

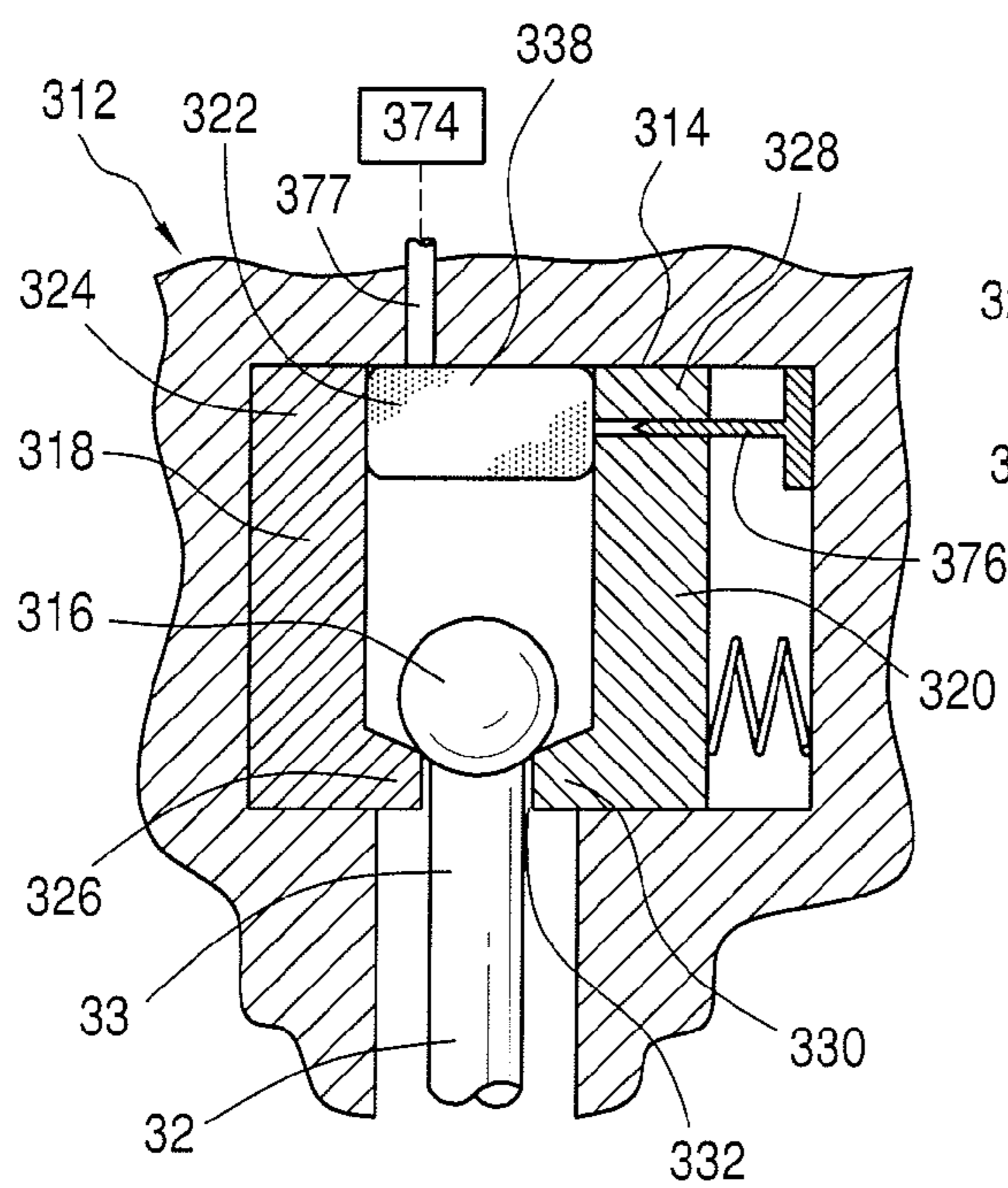

FIG. 56A

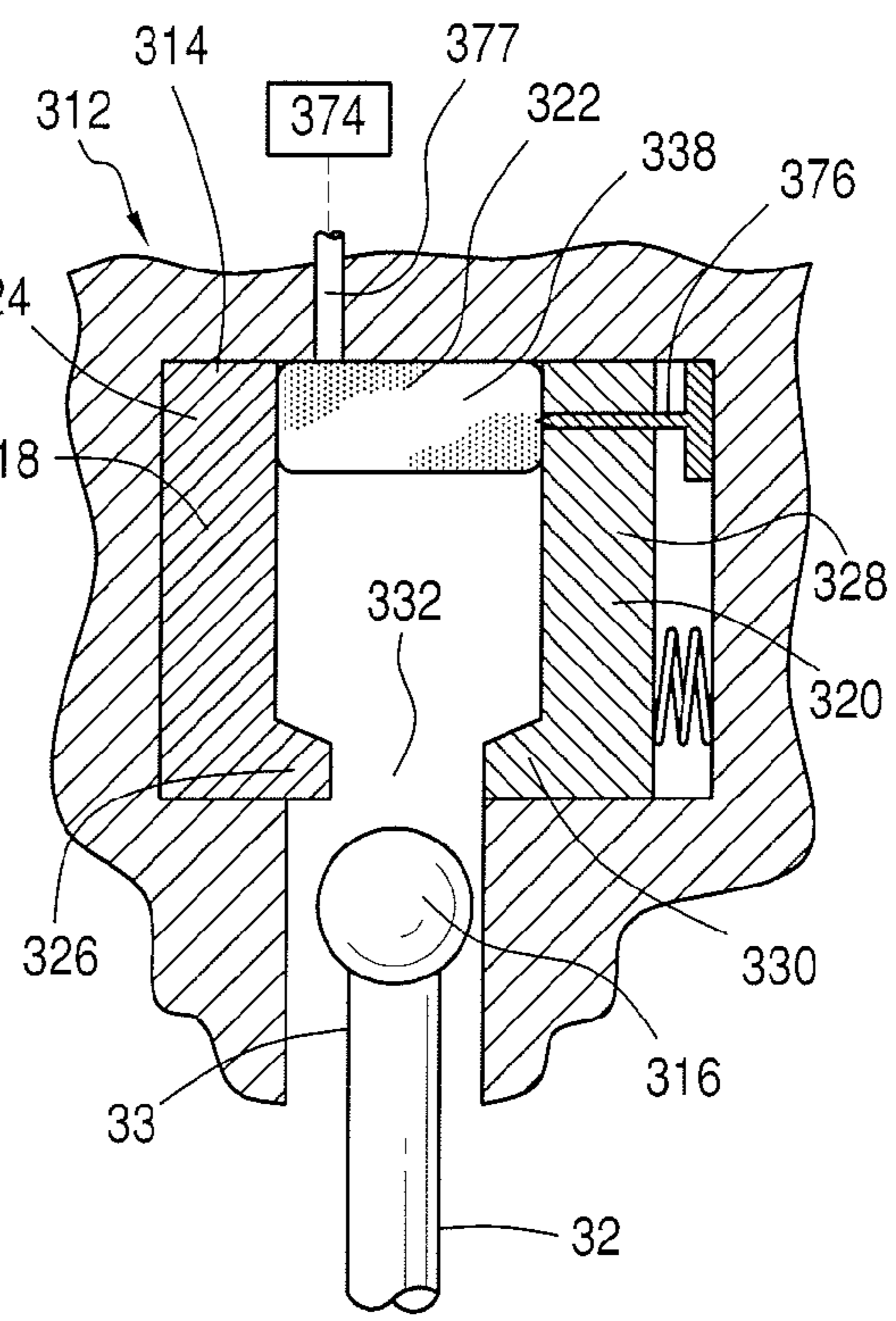

FIG. 56B

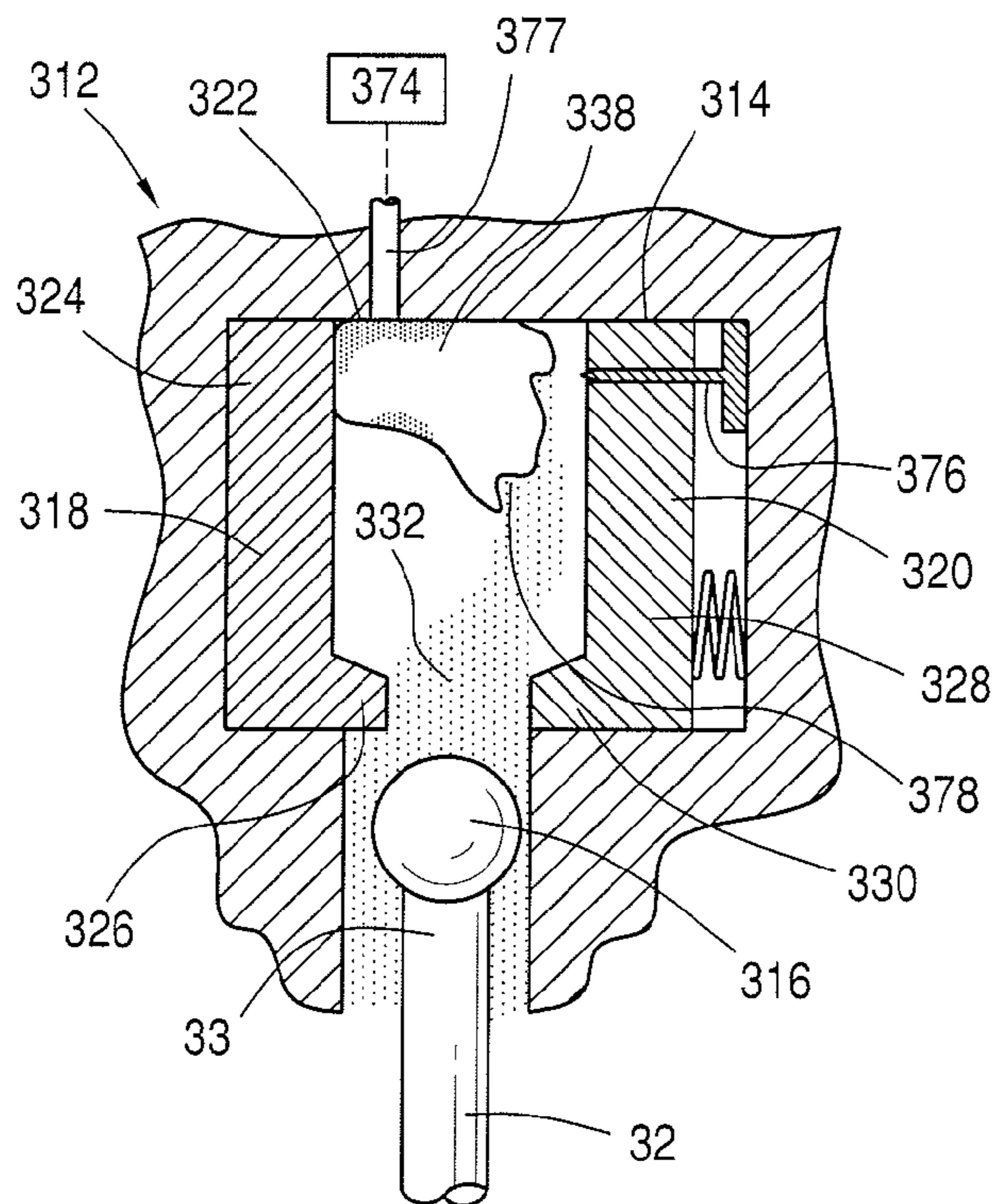

FIG. 56C

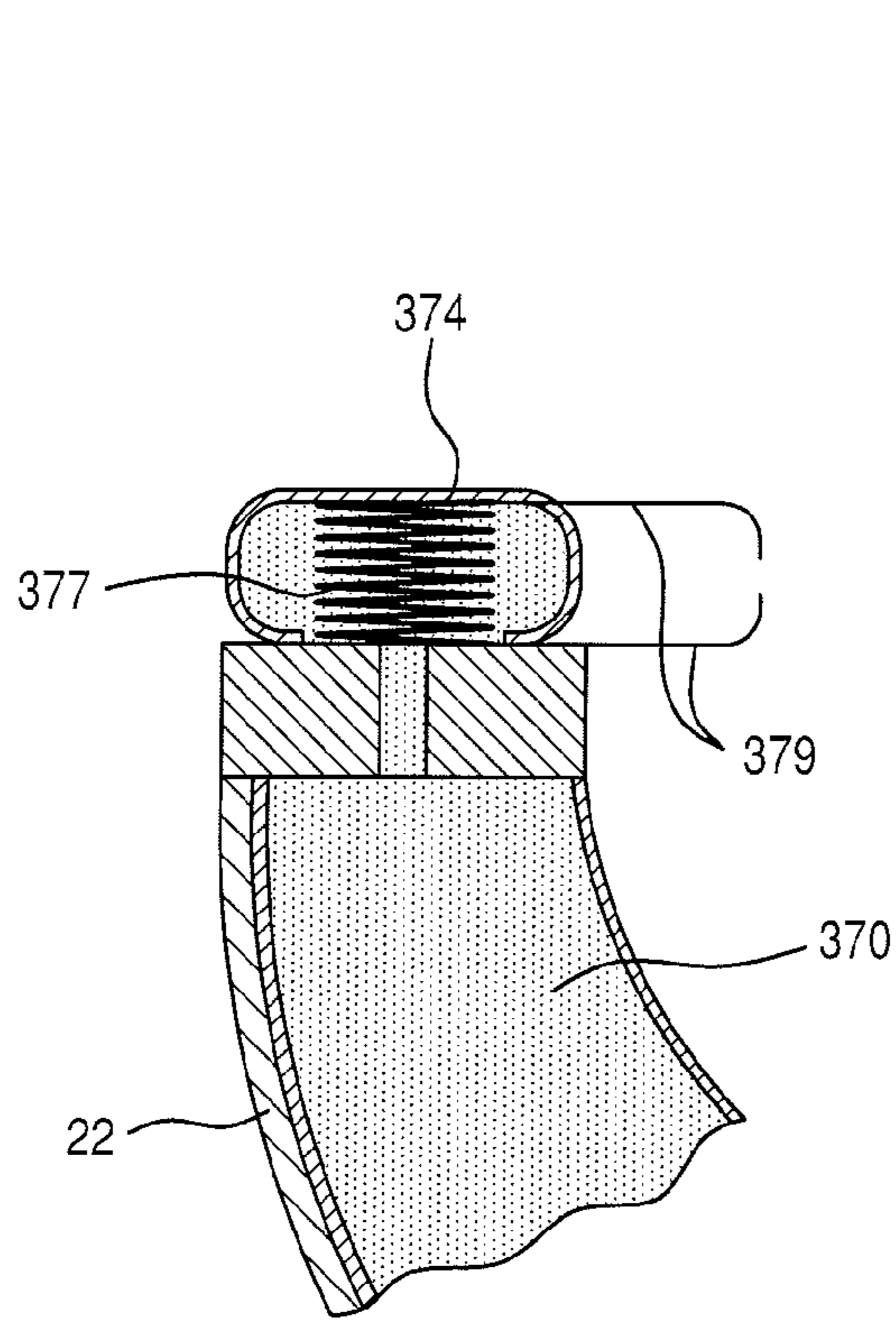

FIG. 57A

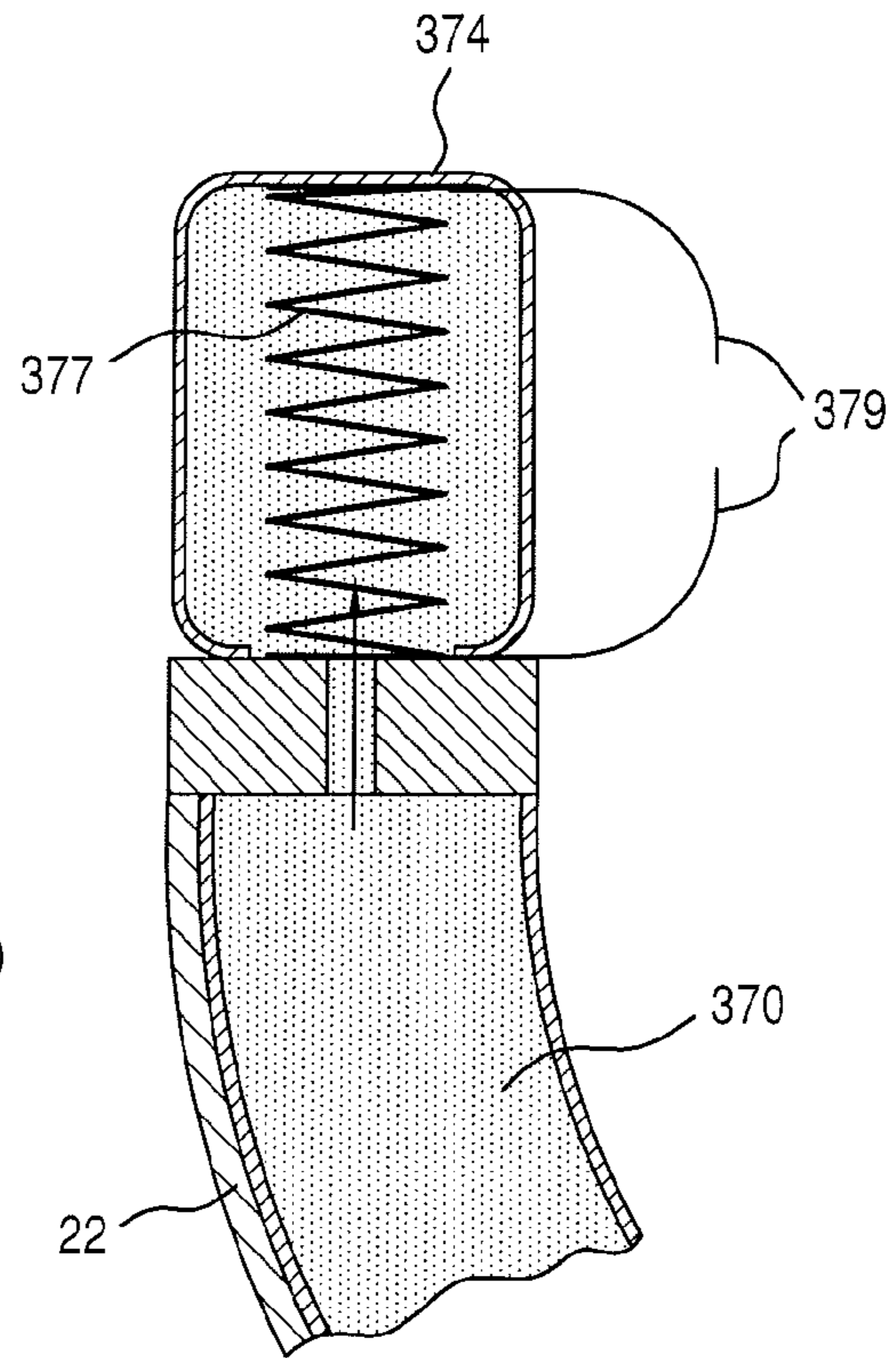

FIG. 57B

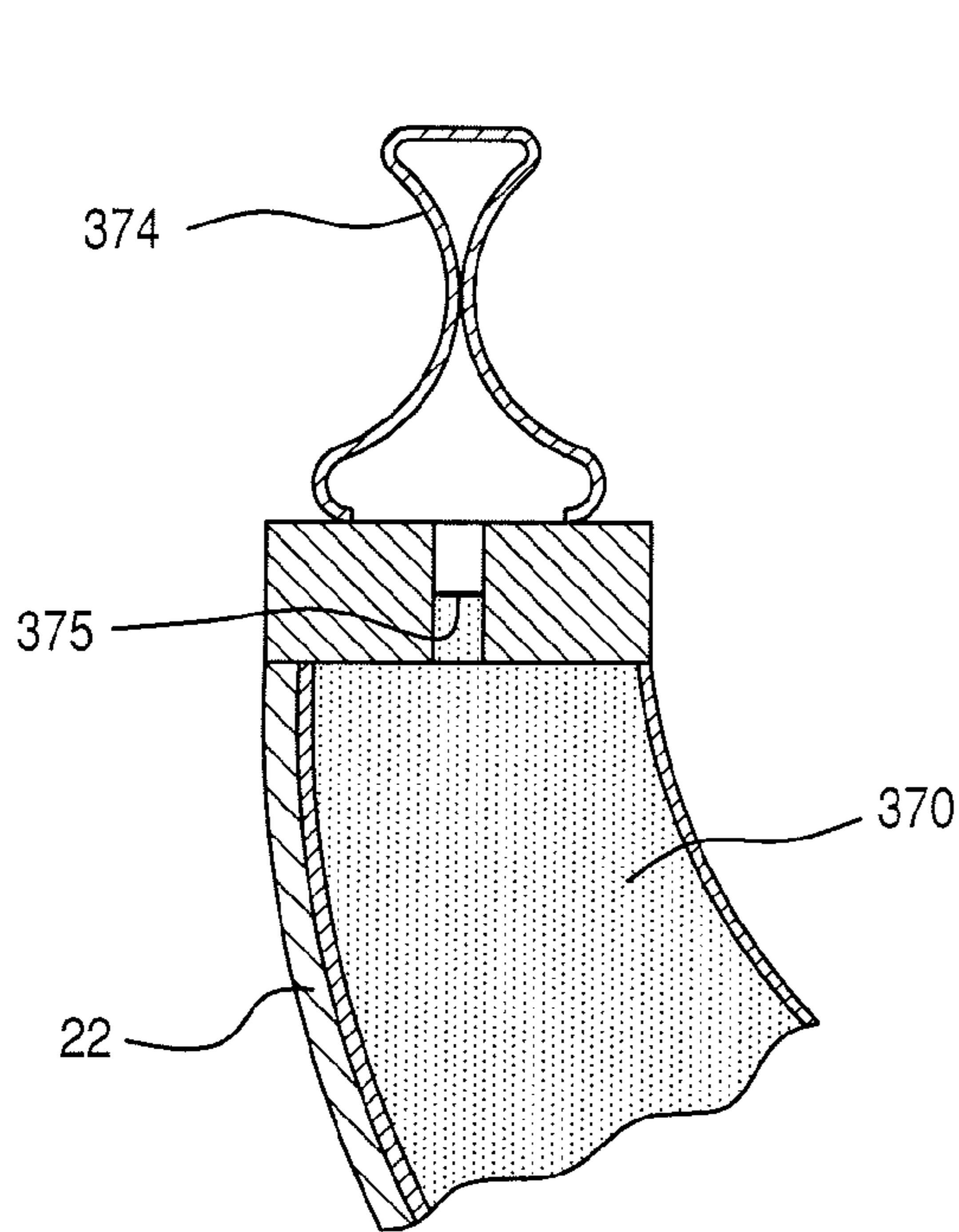

FIG. 58A

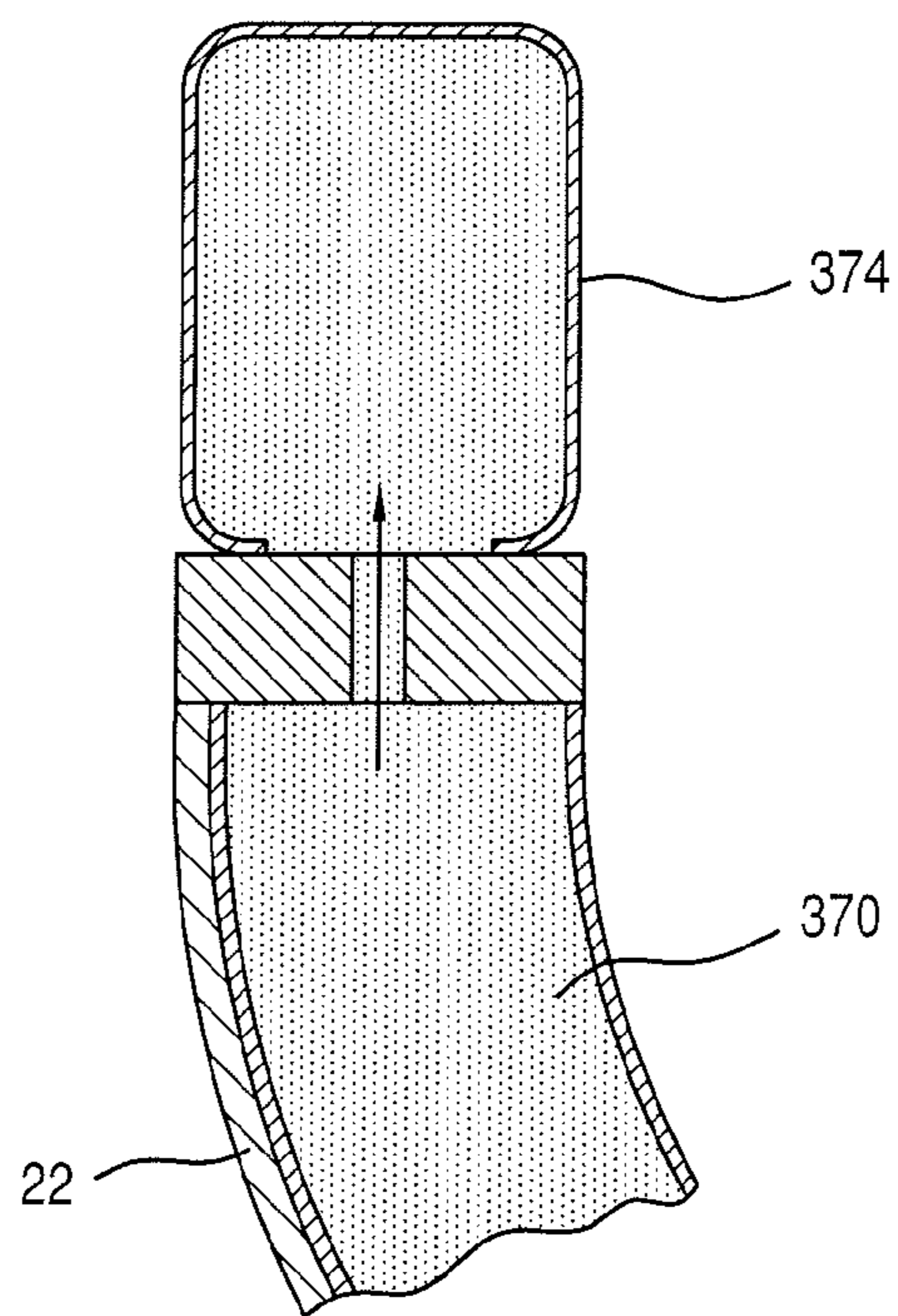

FIG. 58B

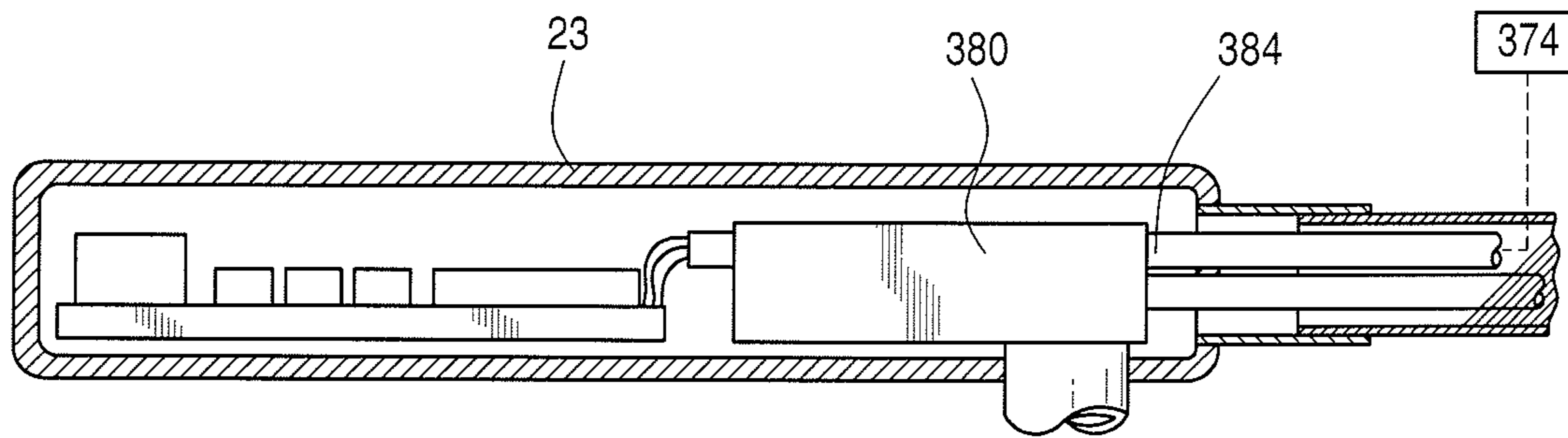

FIG. 59

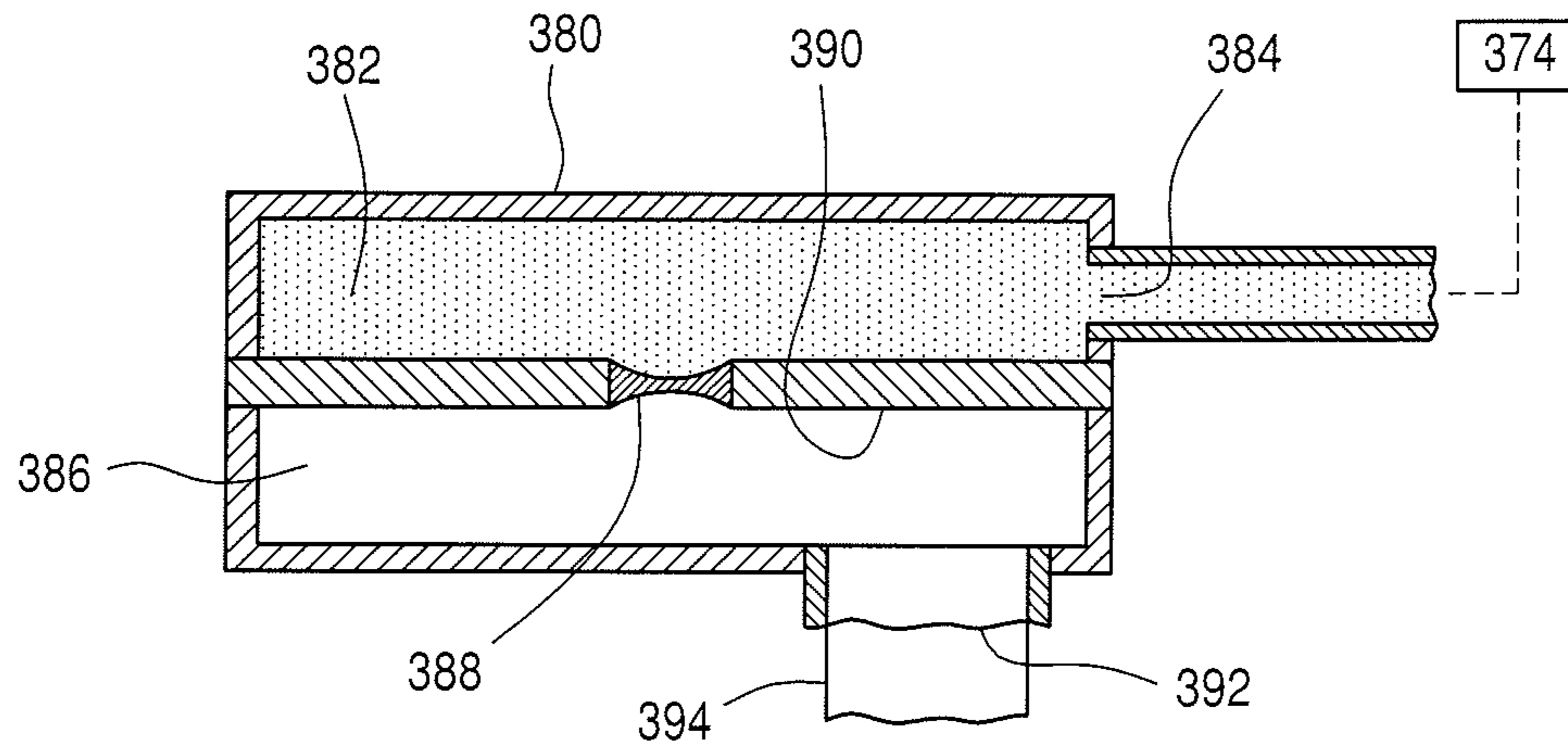

FIG. 60

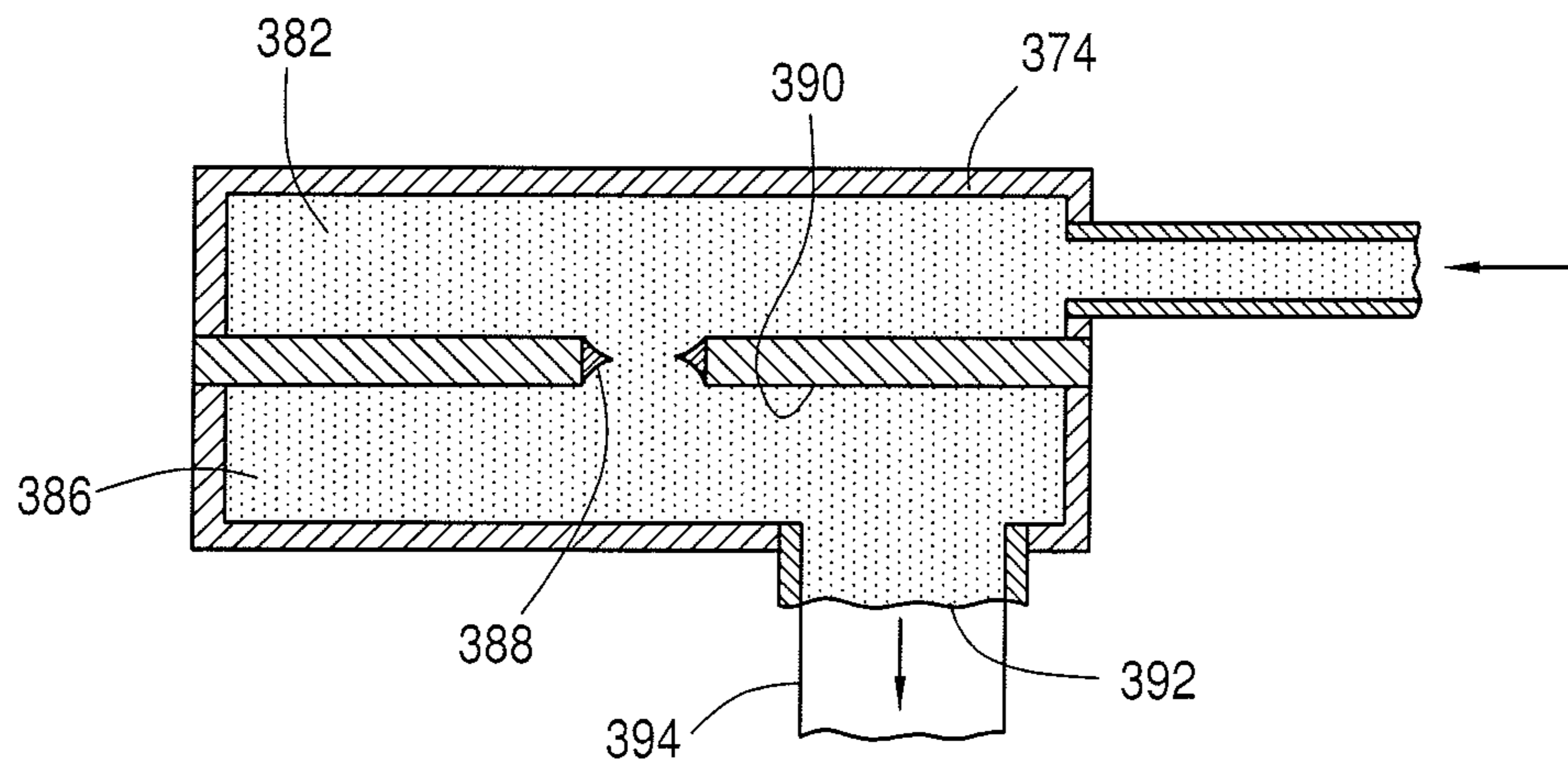

FIG. 61

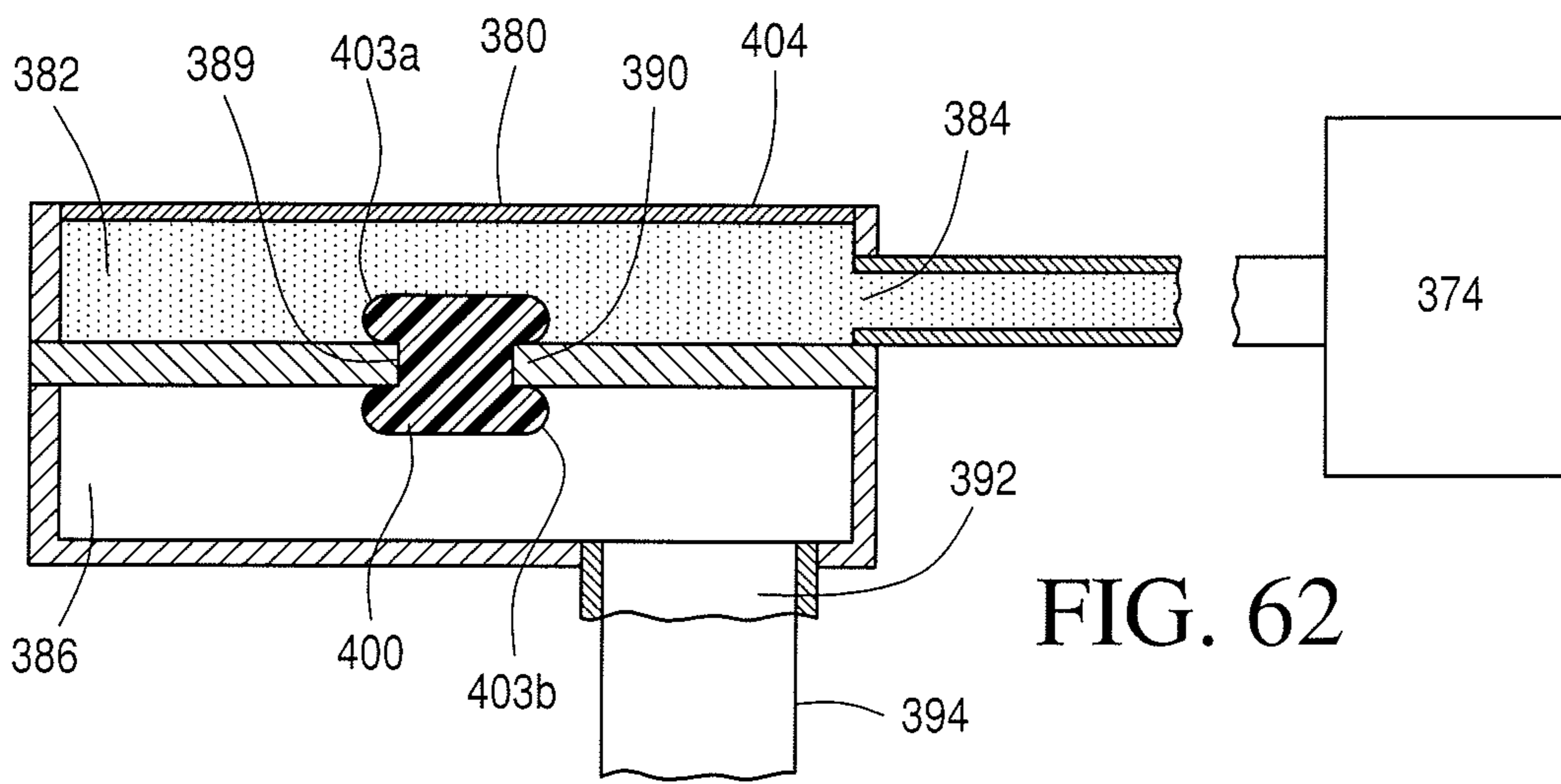

FIG. 62

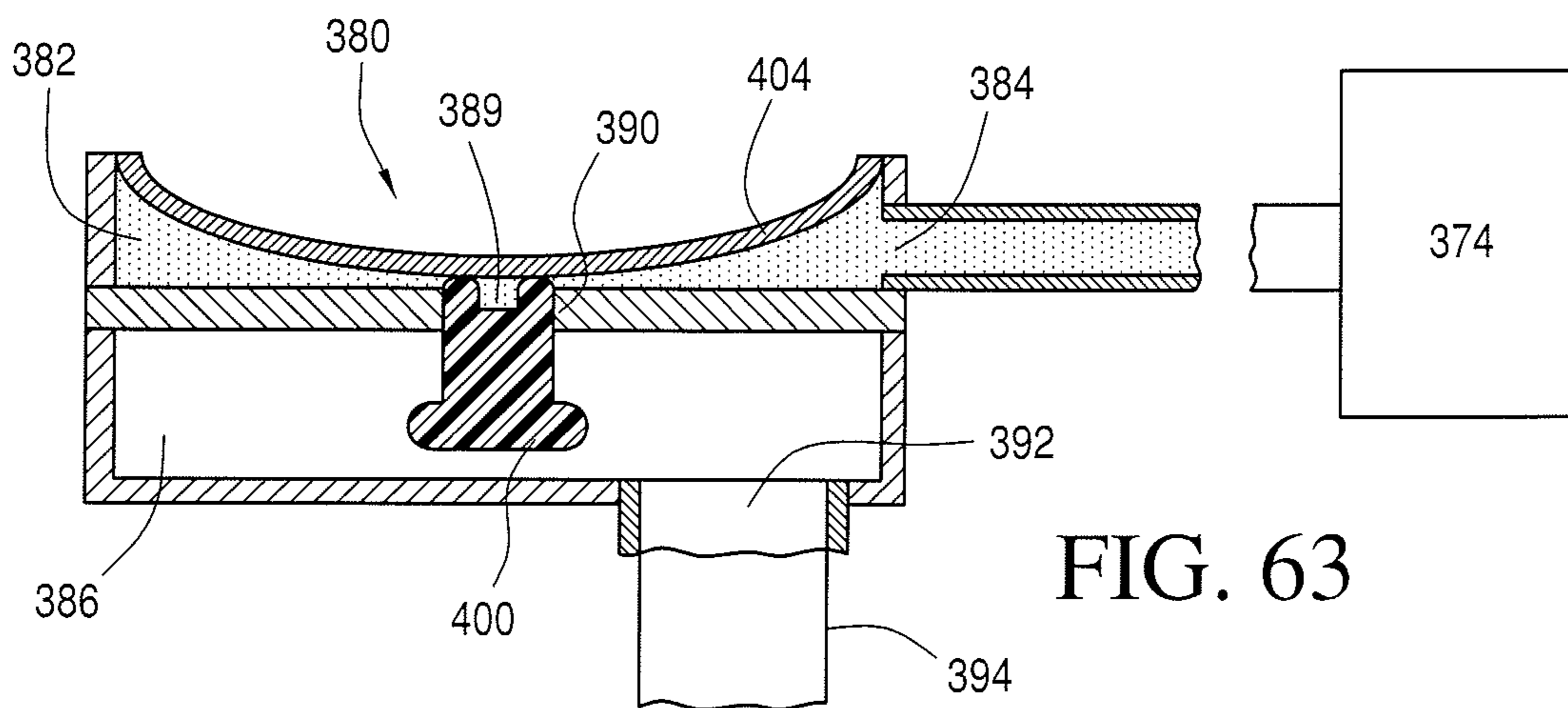

FIG. 63

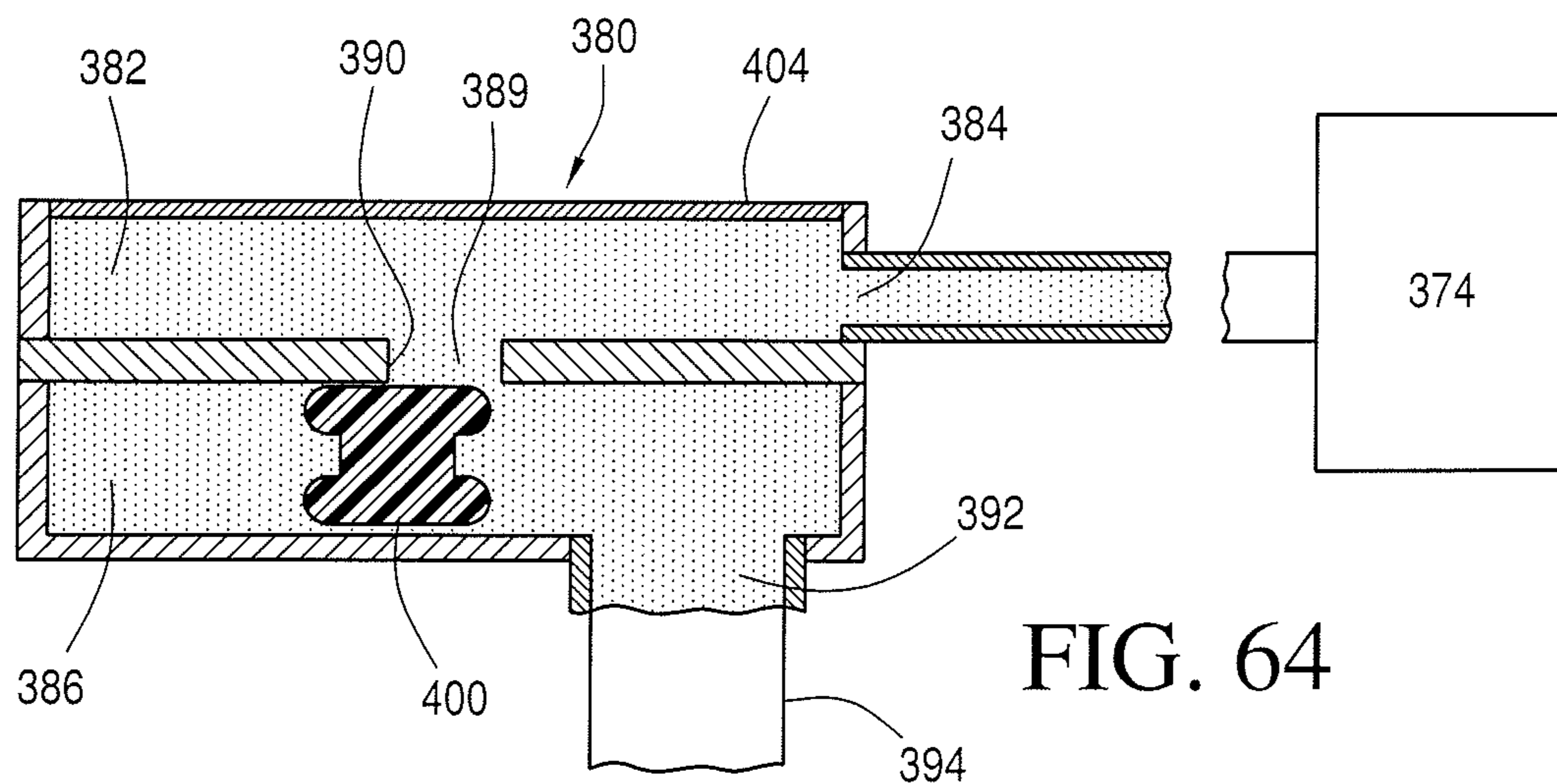

FIG. 64

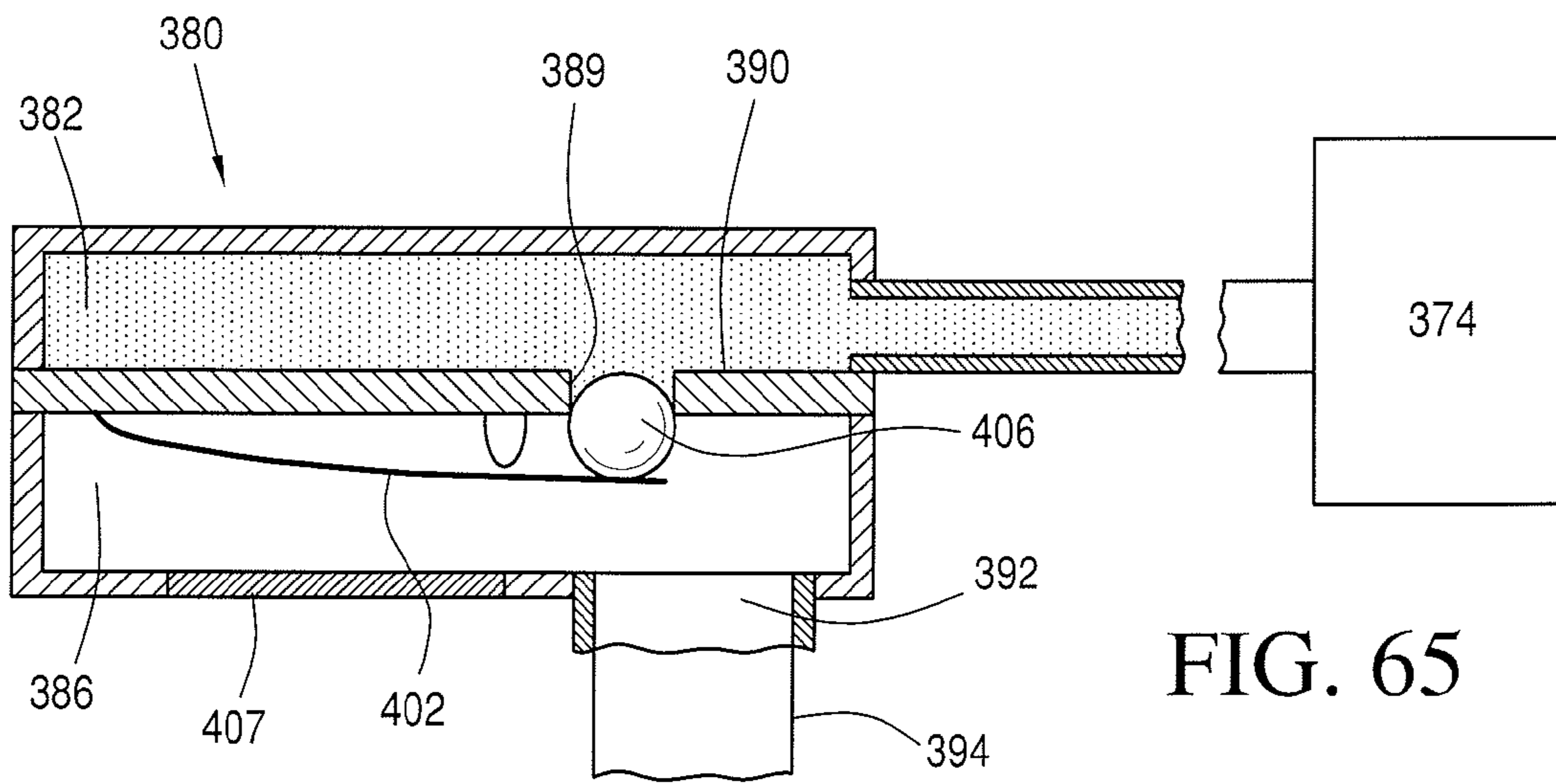

FIG. 65

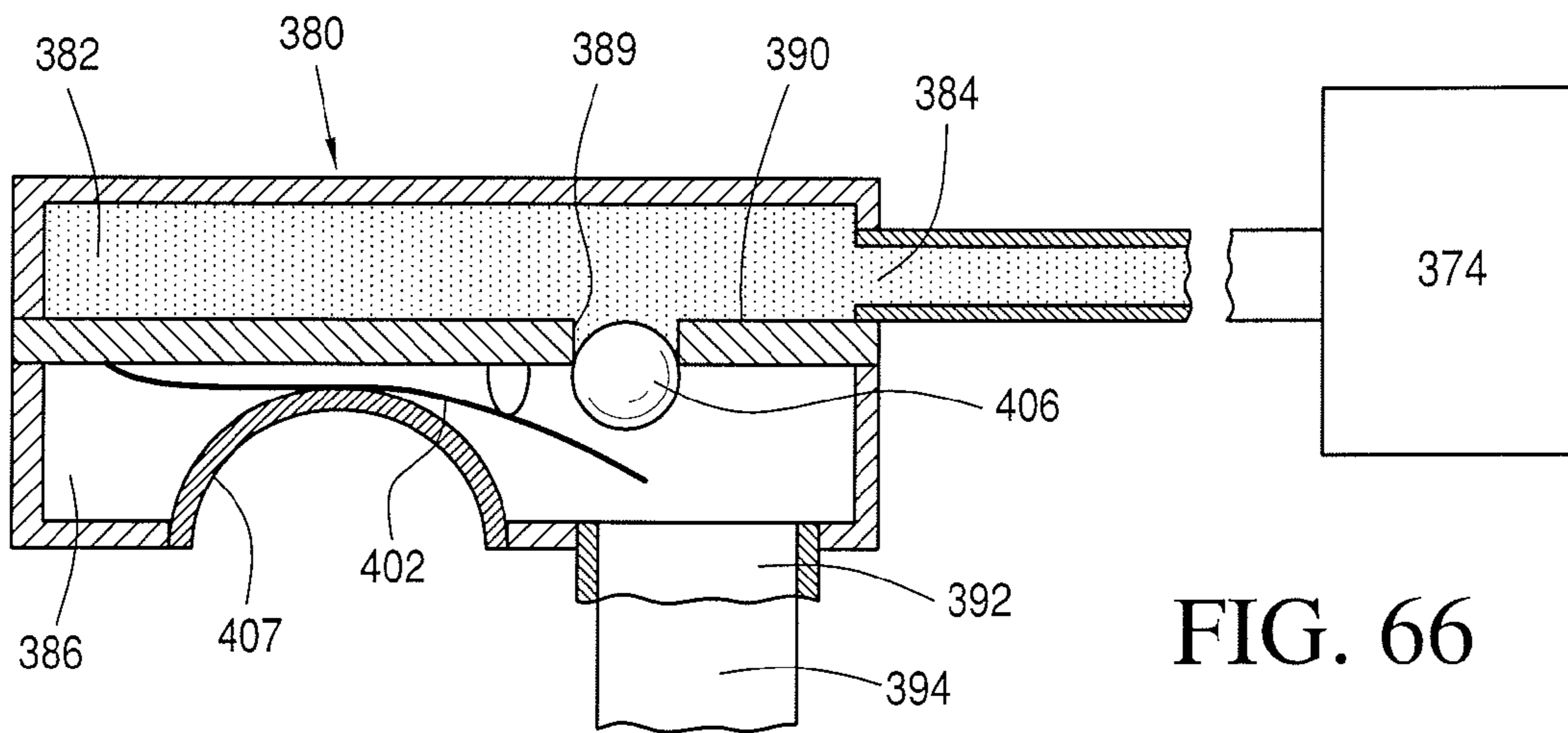

FIG. 66

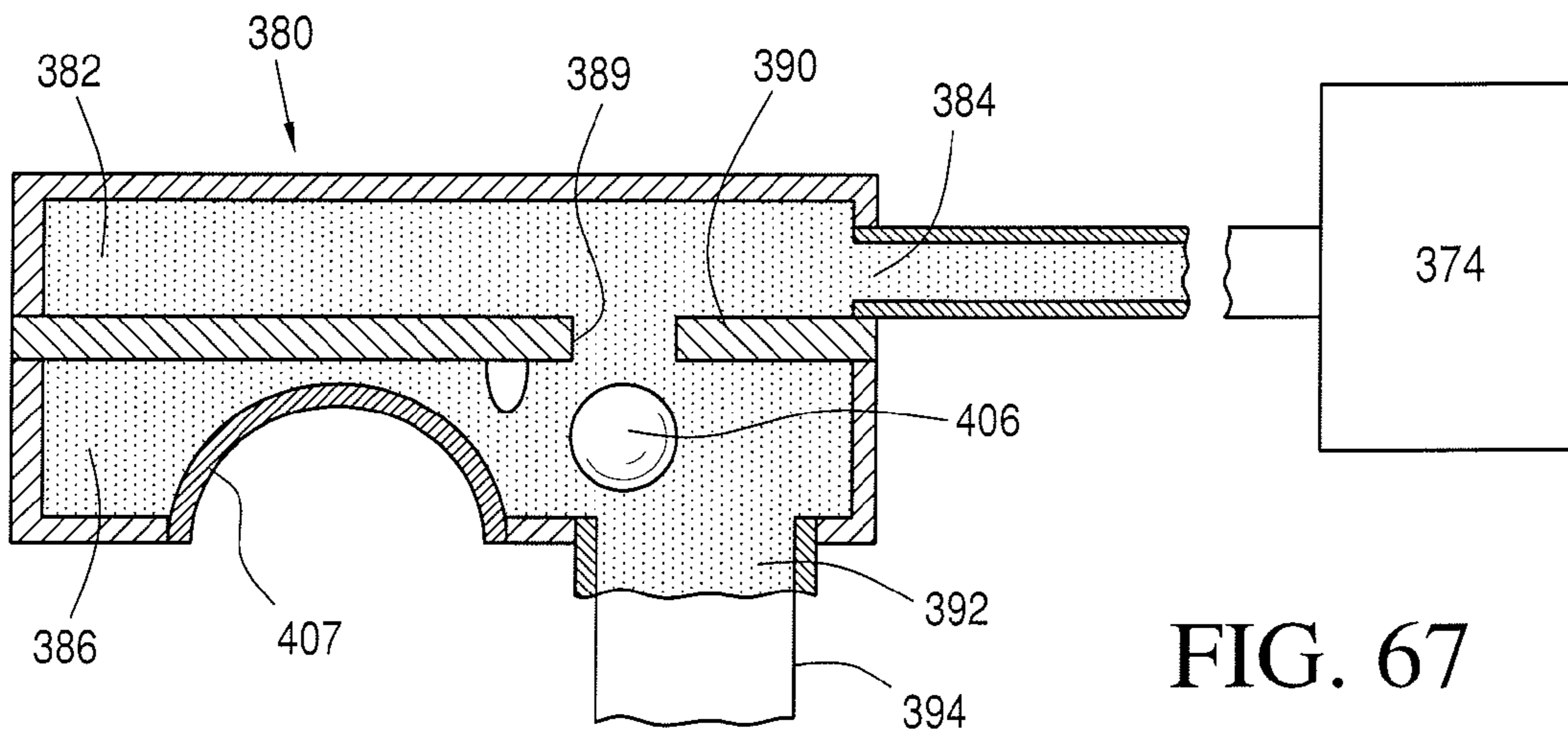

FIG. 67

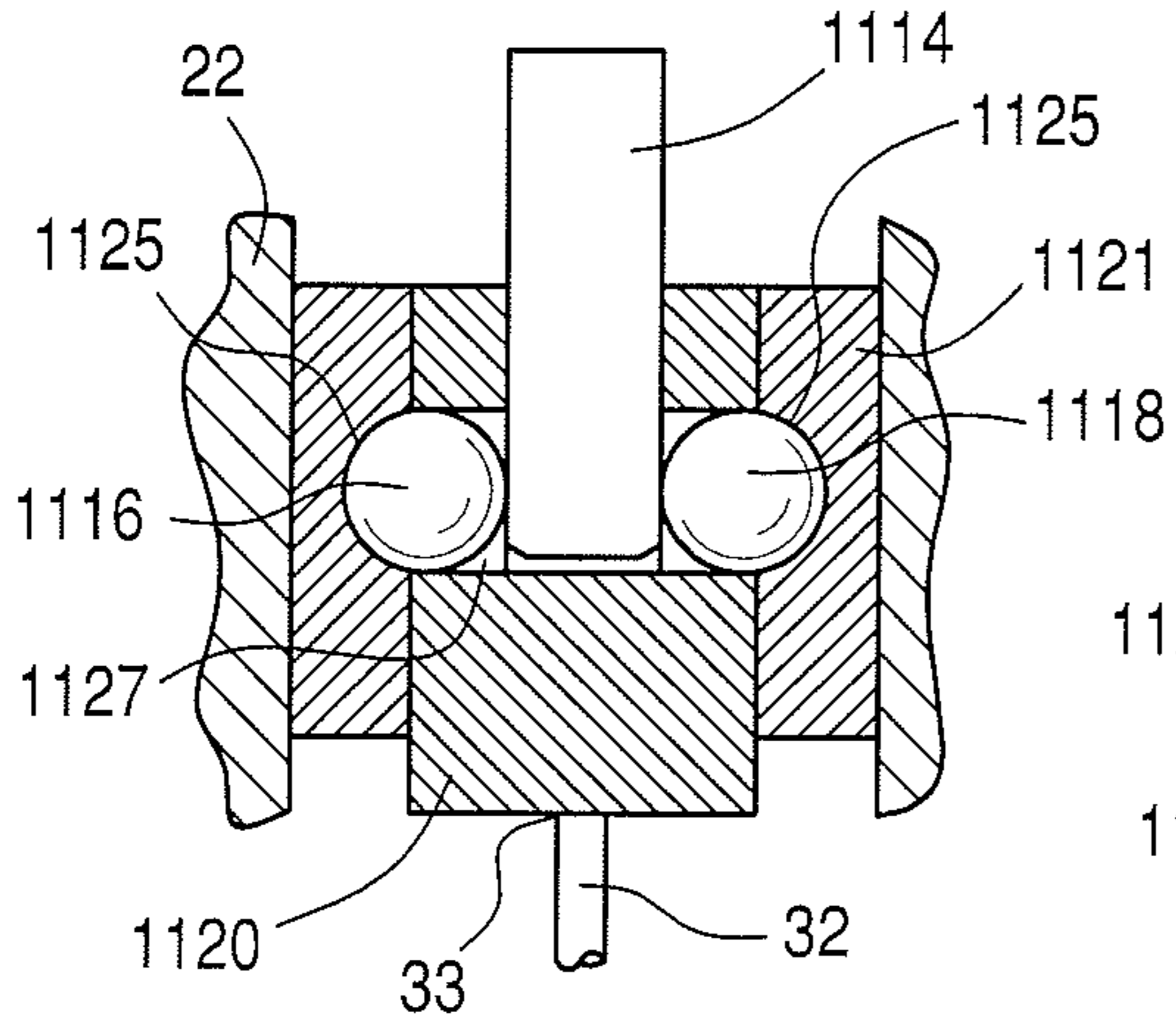

FIG. 68

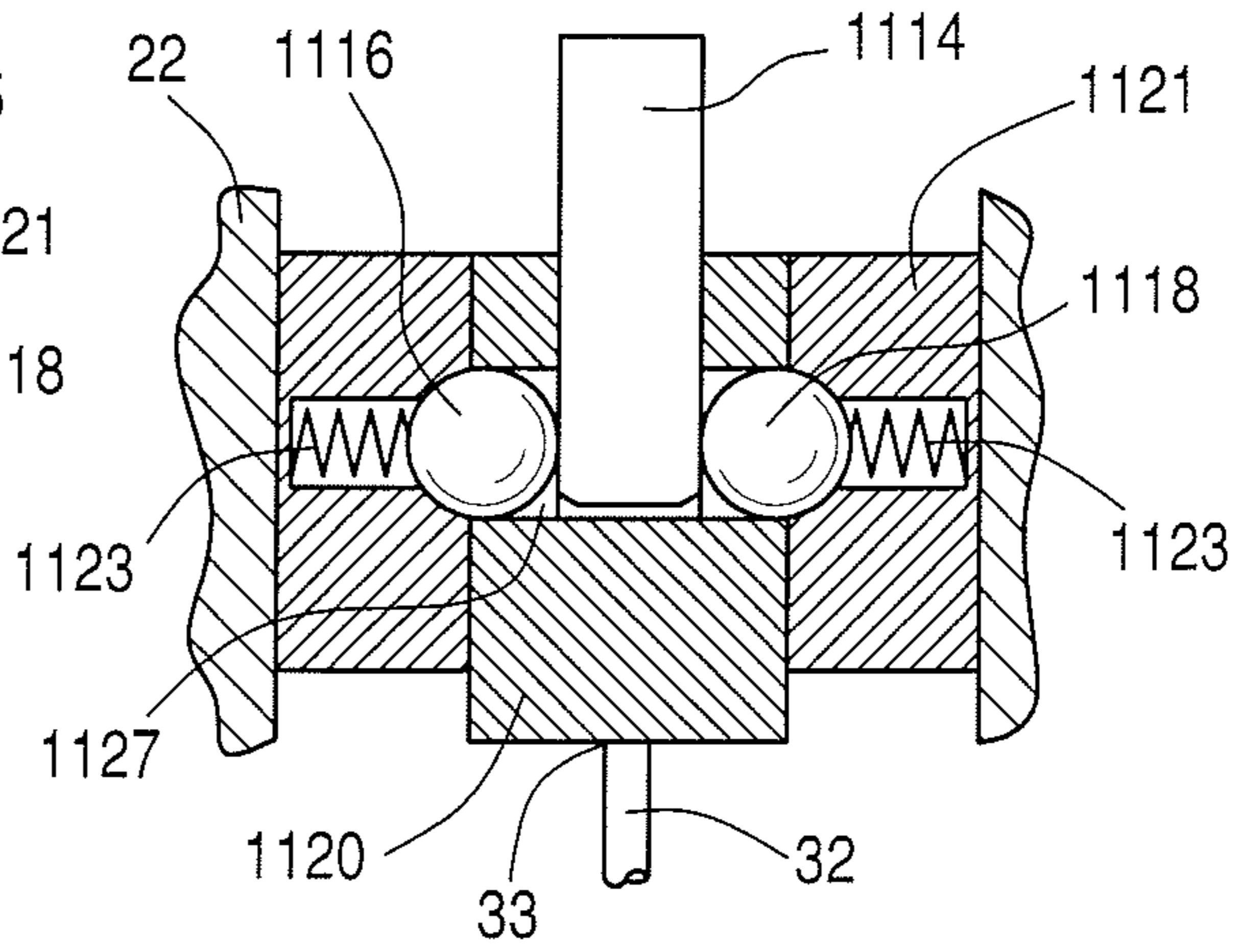

FIG. 69

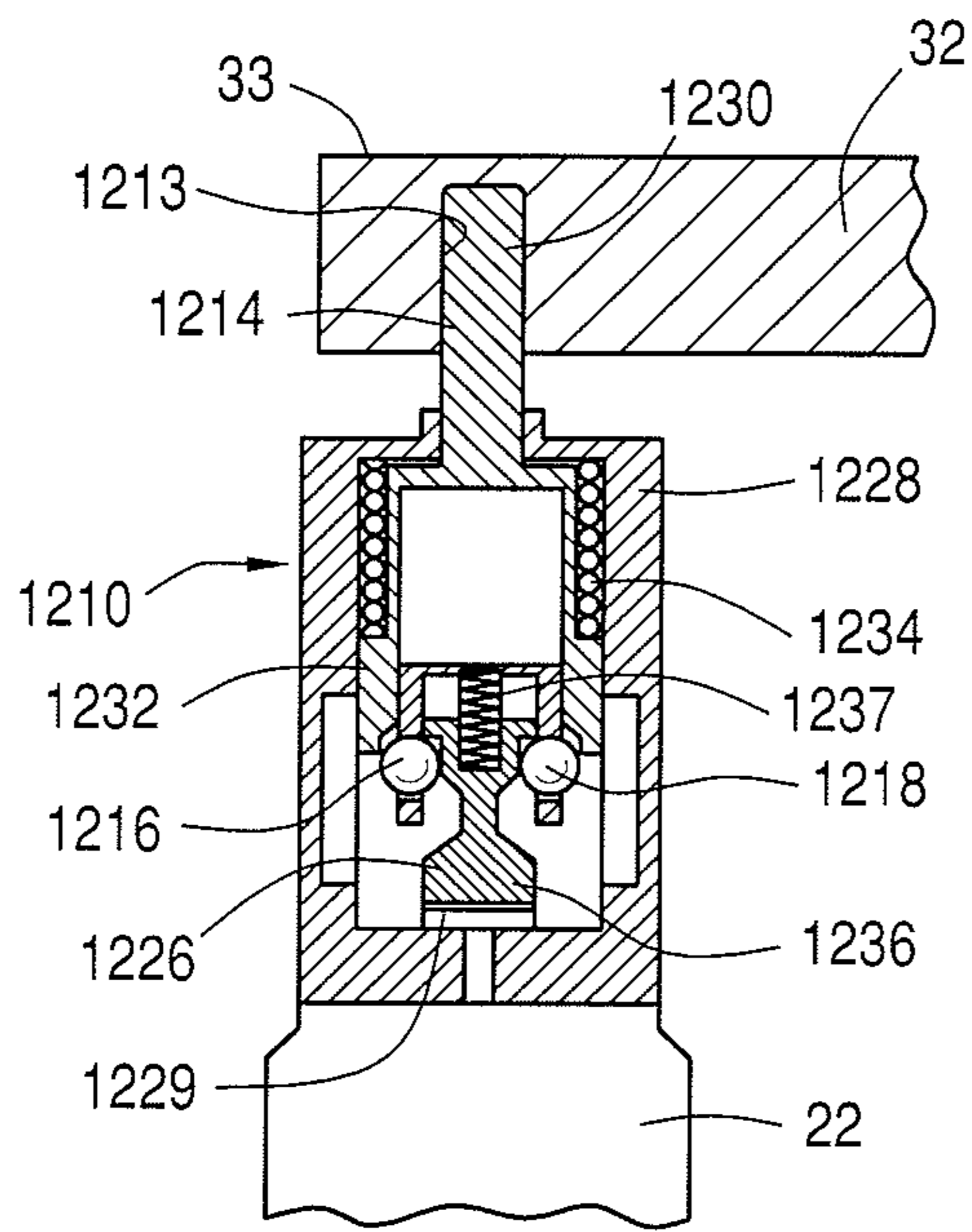

FIG. 70

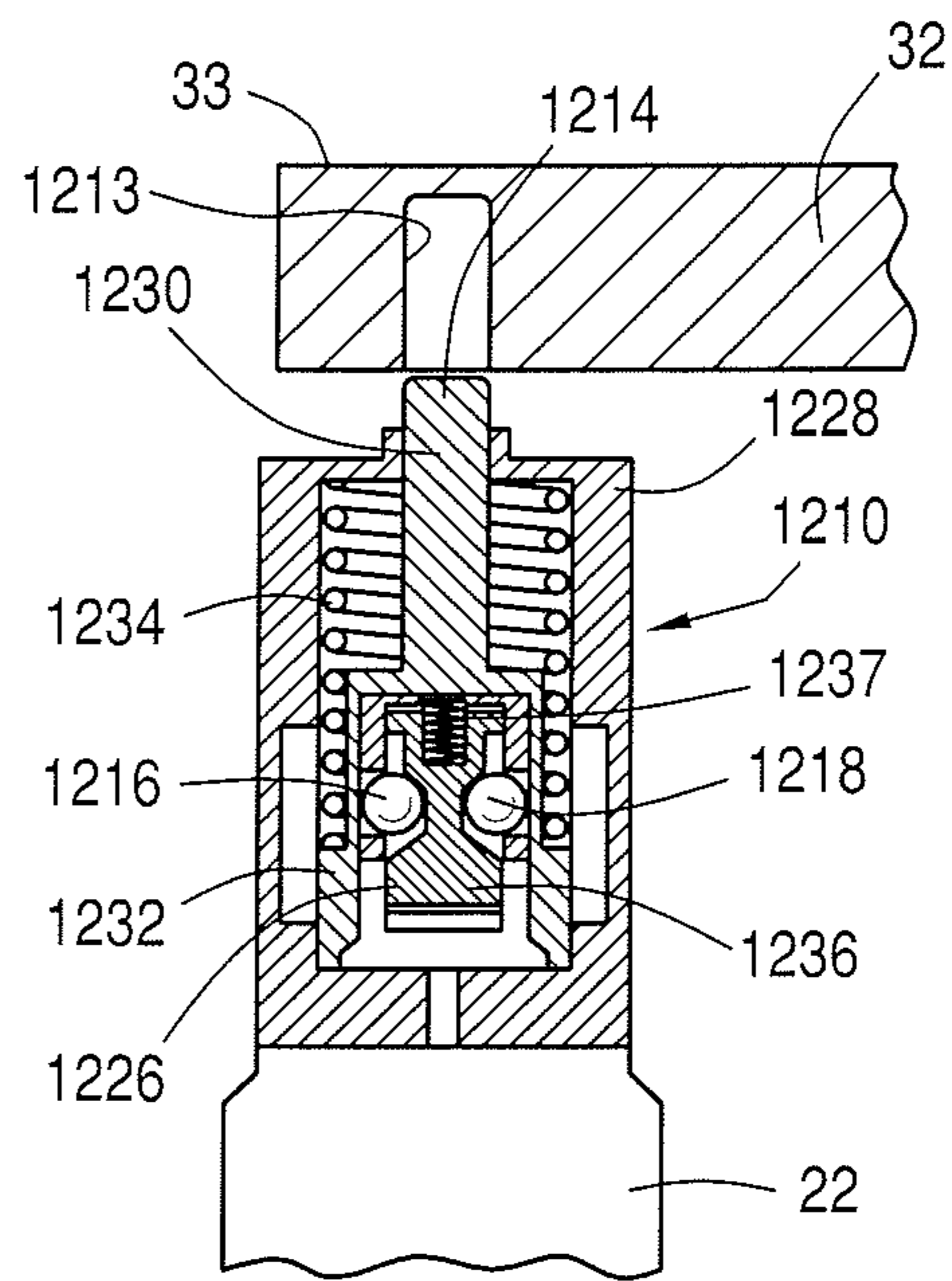

FIG. 71

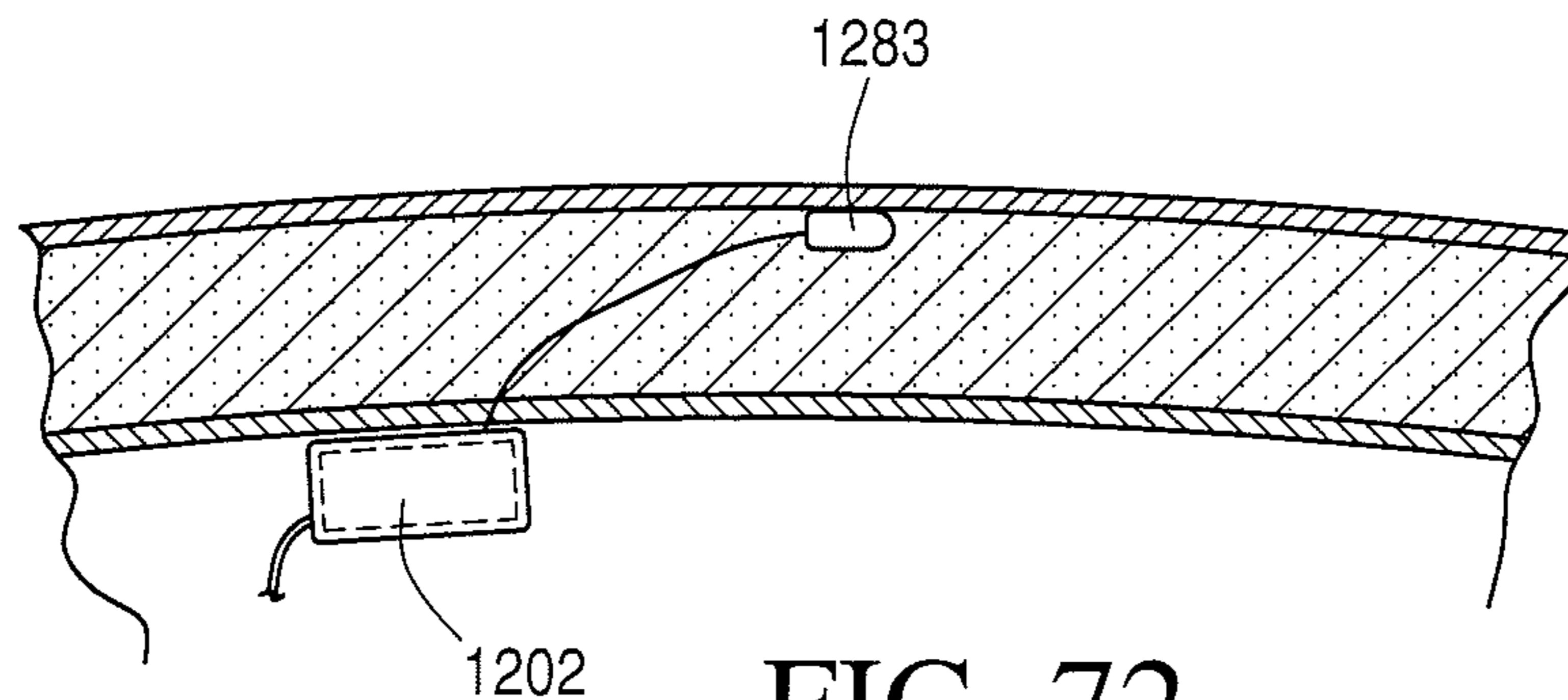

FIG. 72

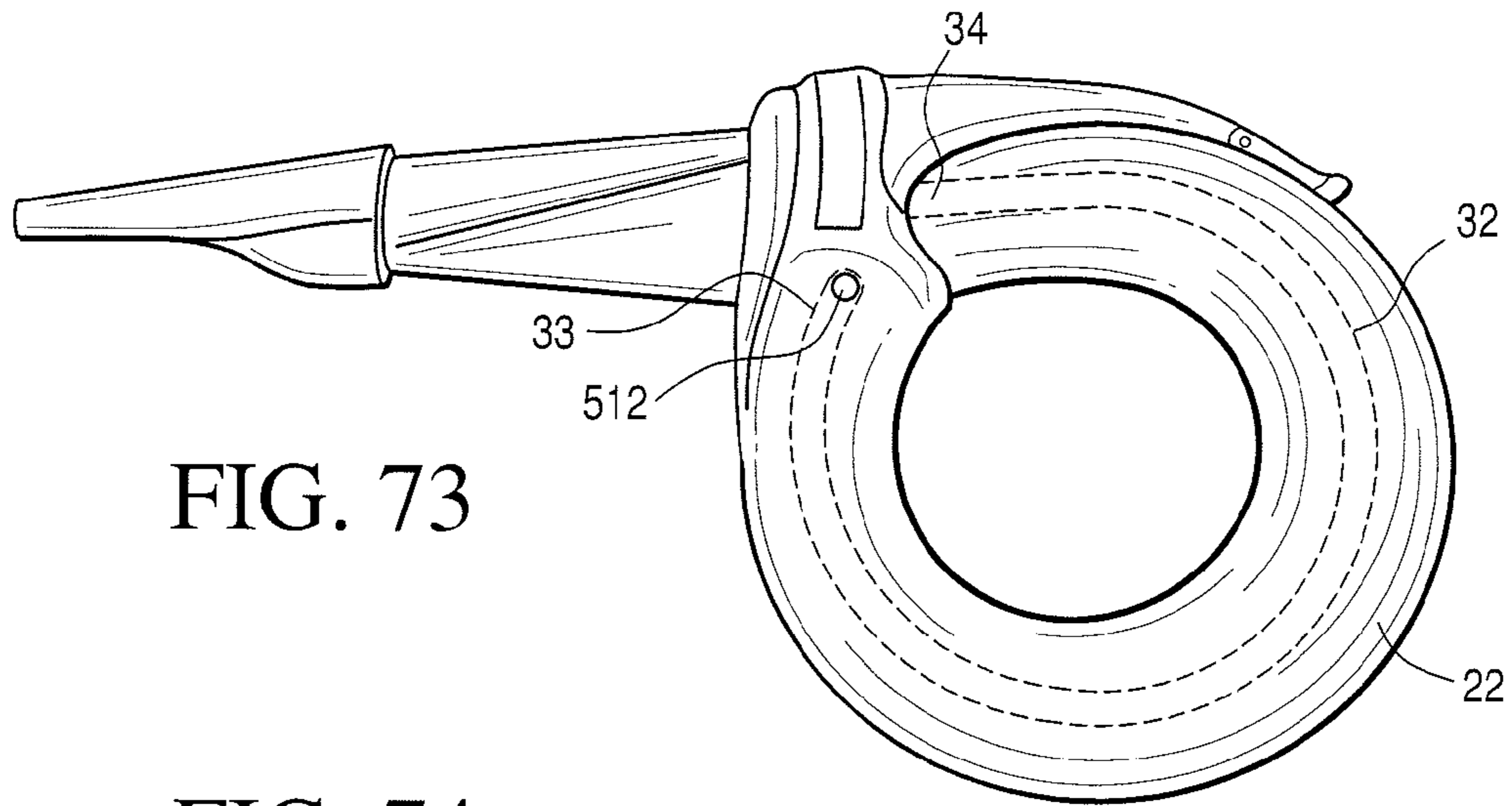

FIG. 73

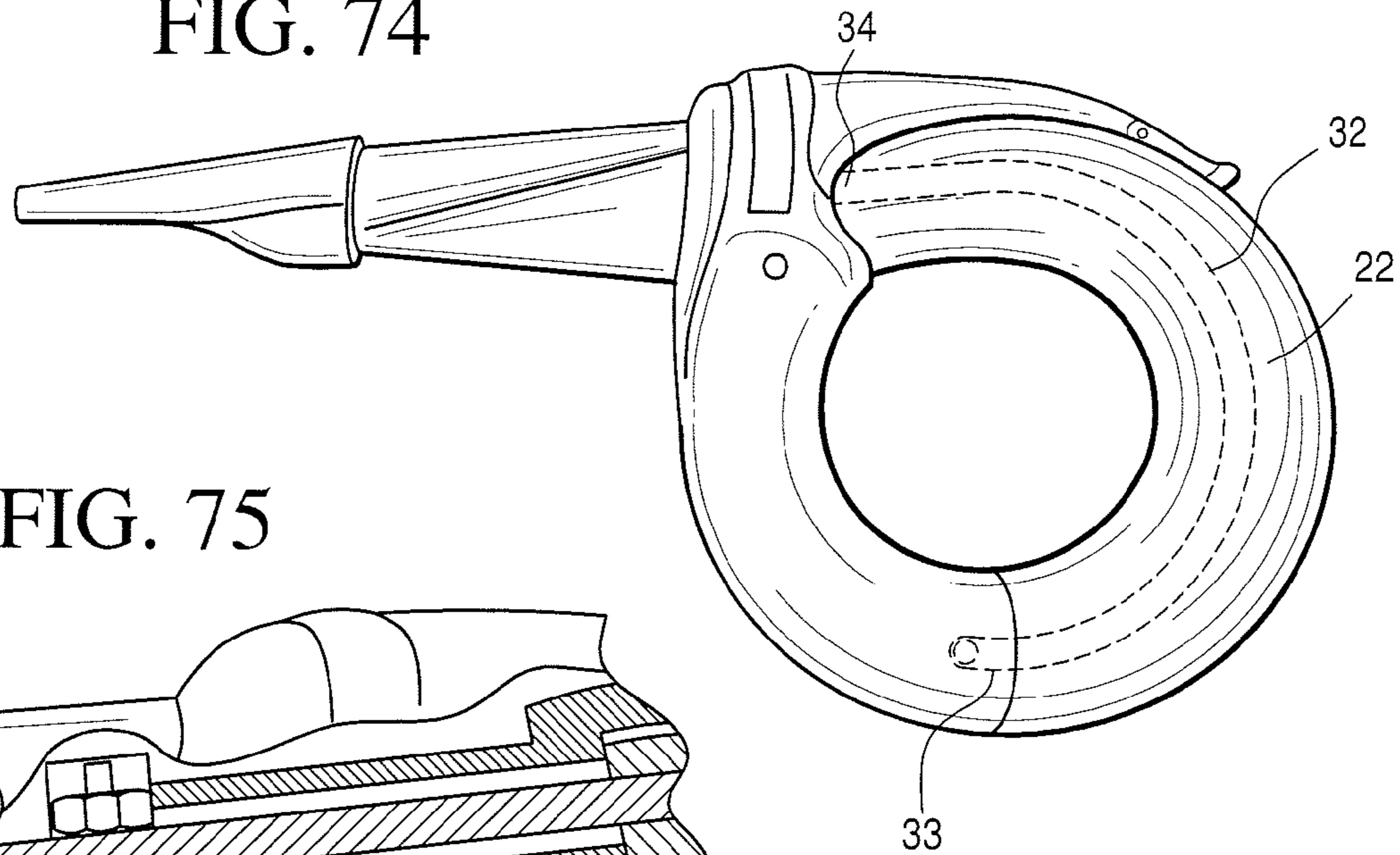

FIG. 74

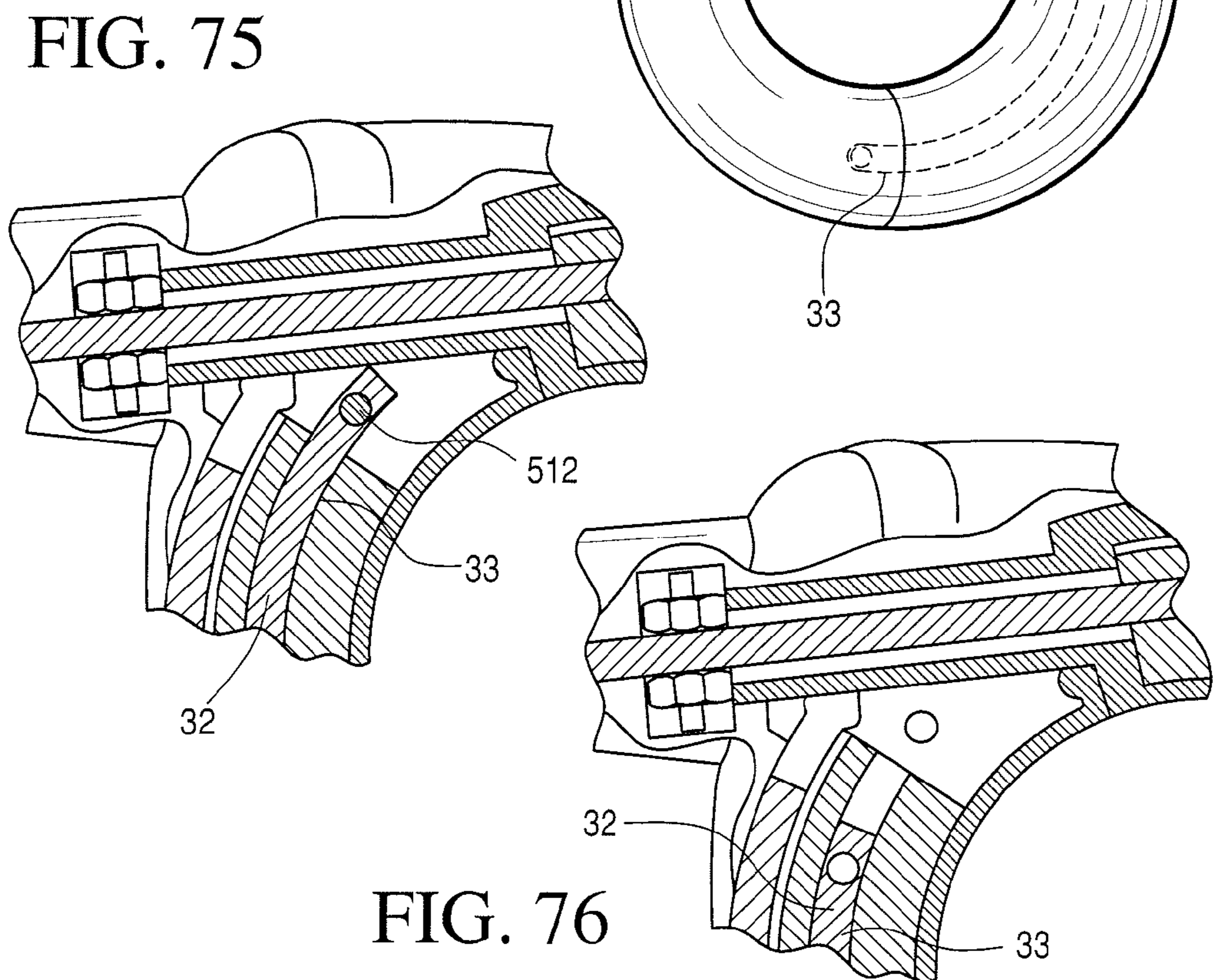

FIG. 75

FIG. 76

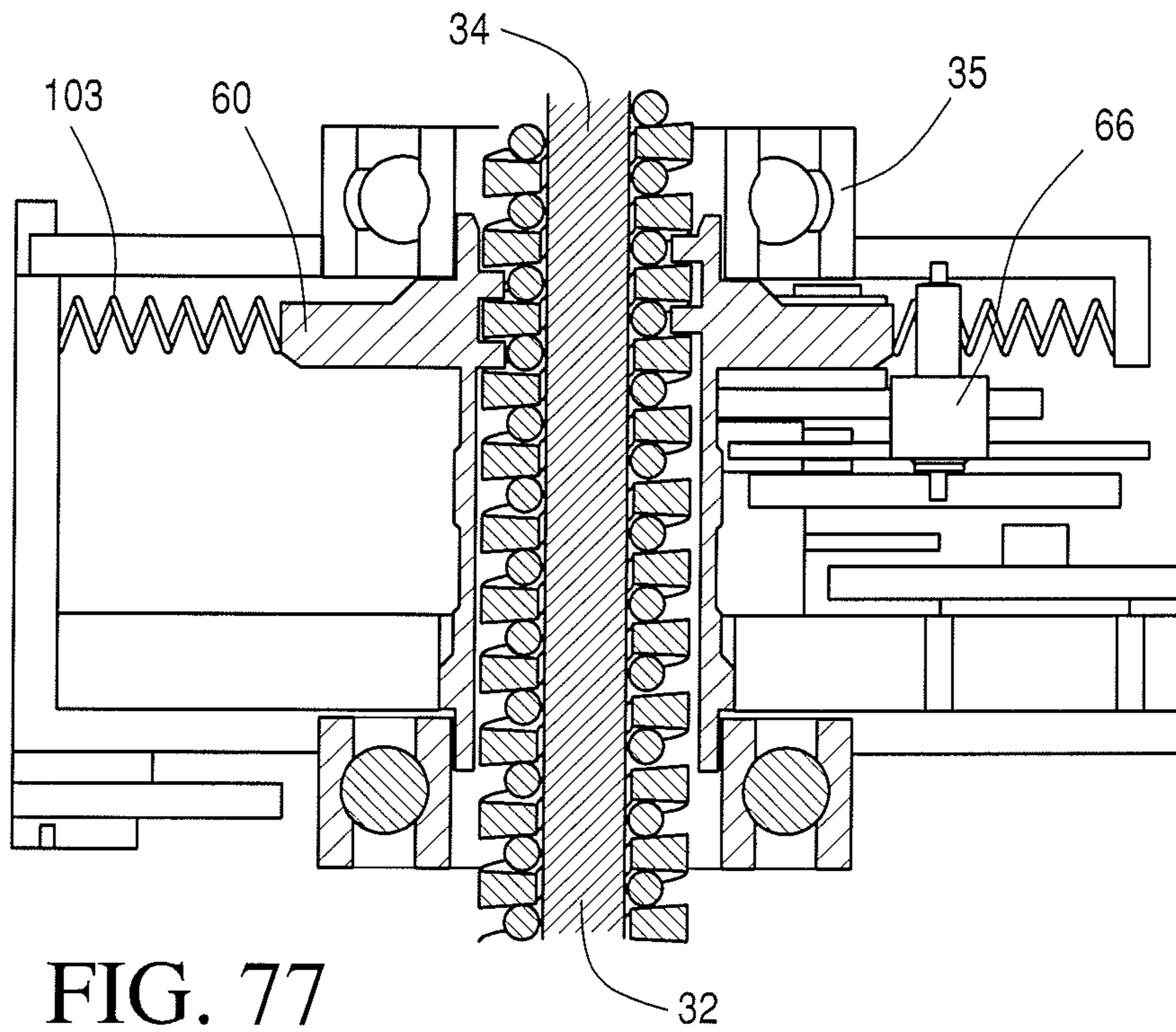

FIG. 77

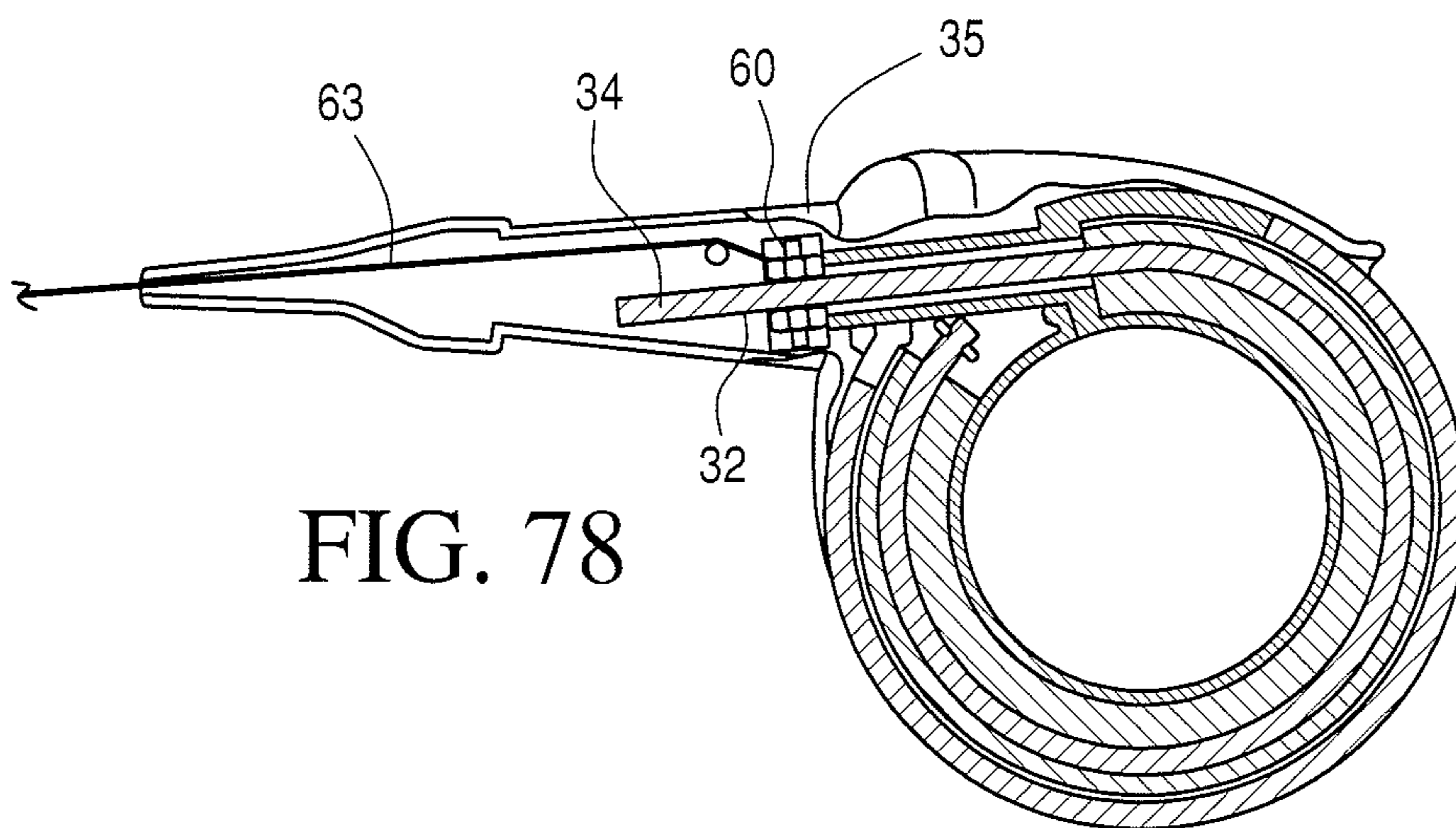

FIG. 78

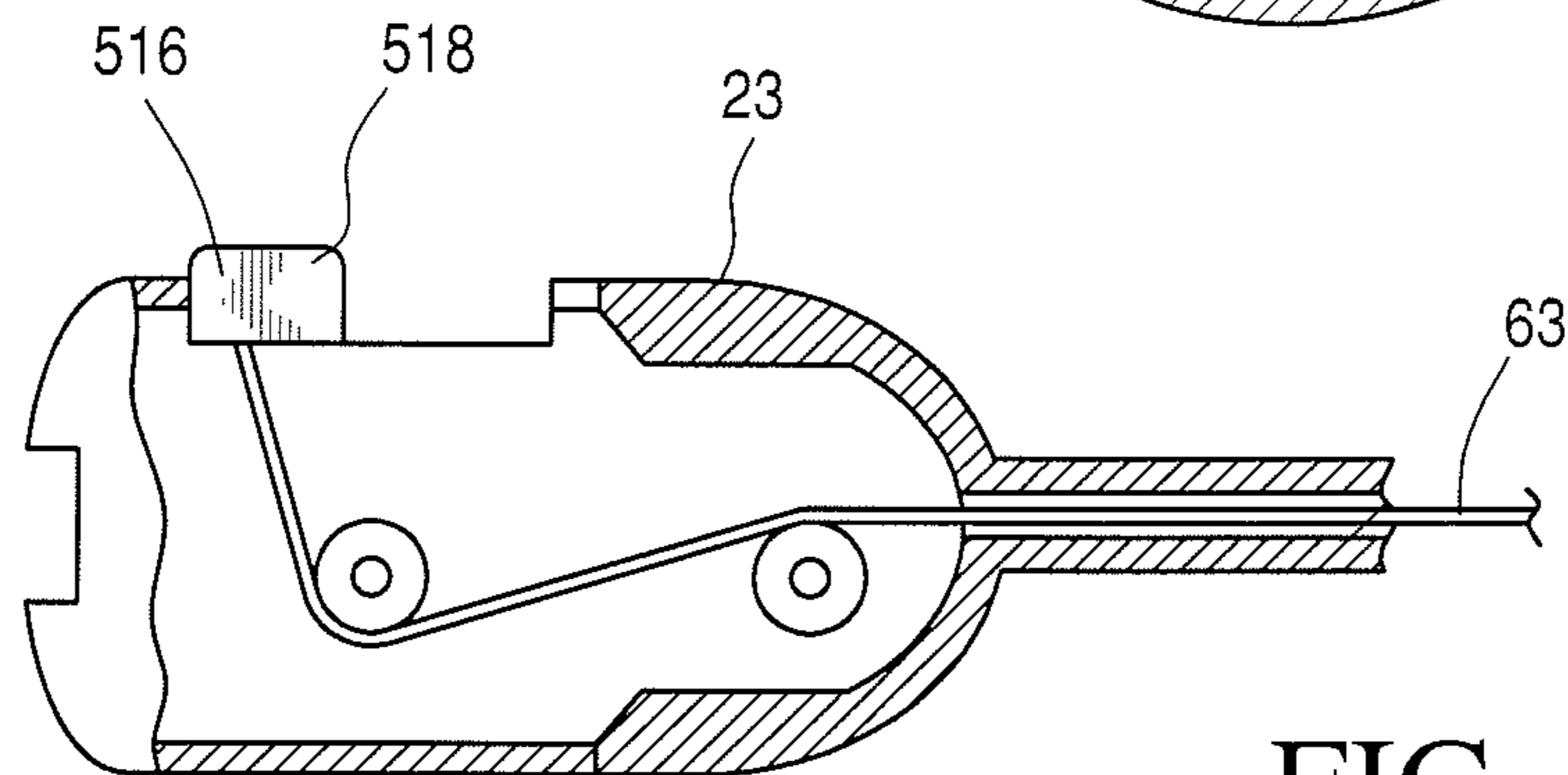

FIG. 79

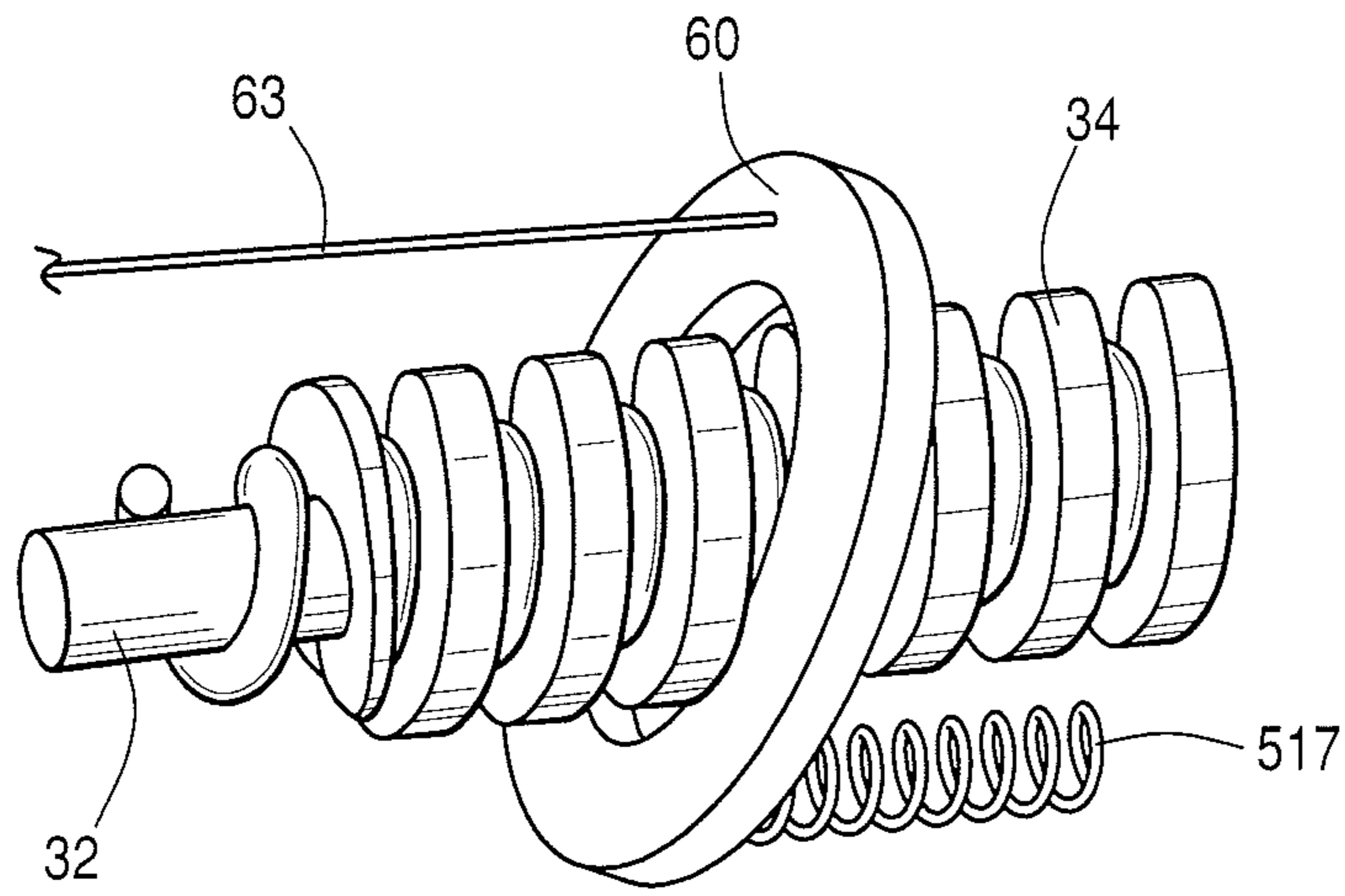

FIG. 80

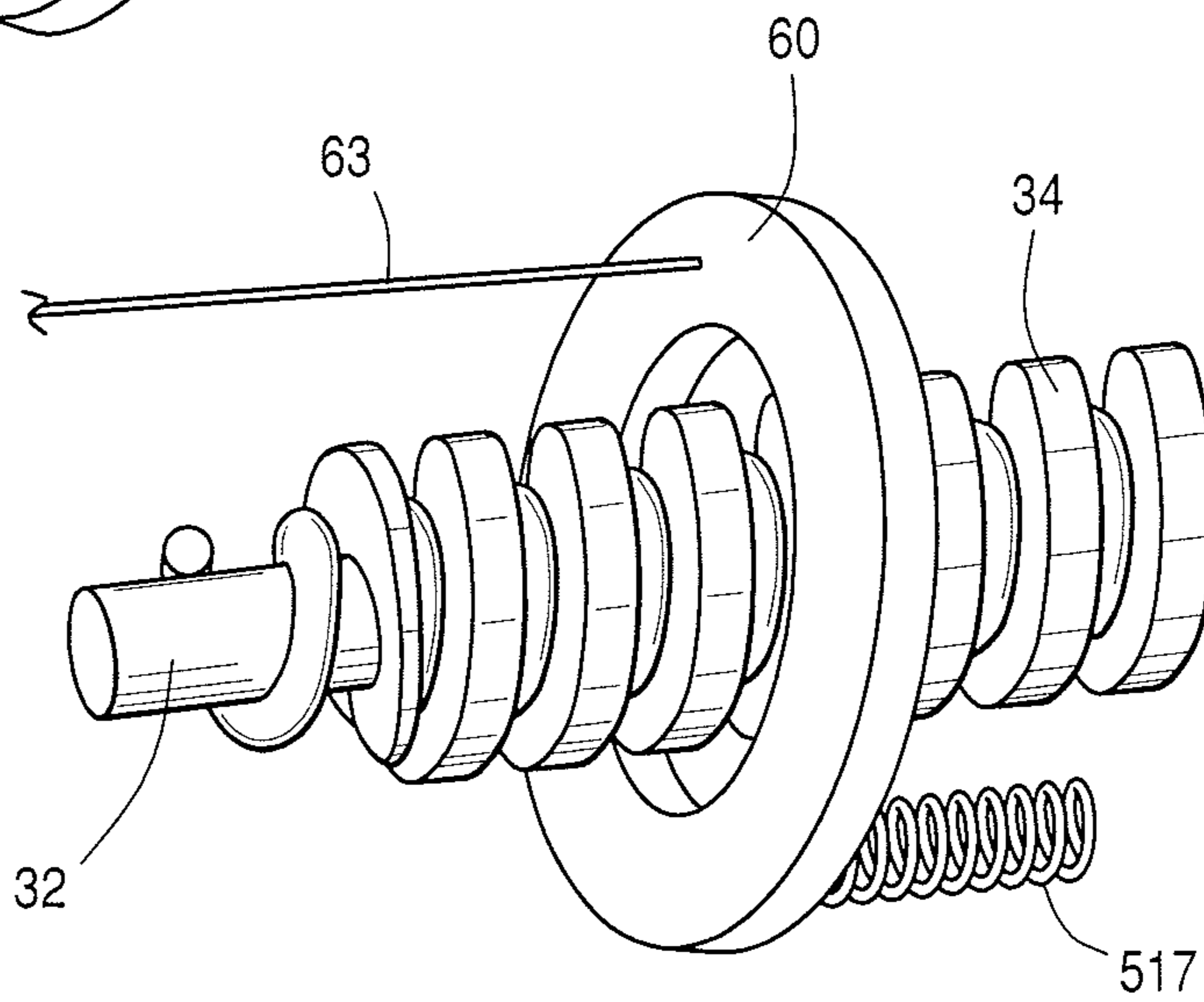
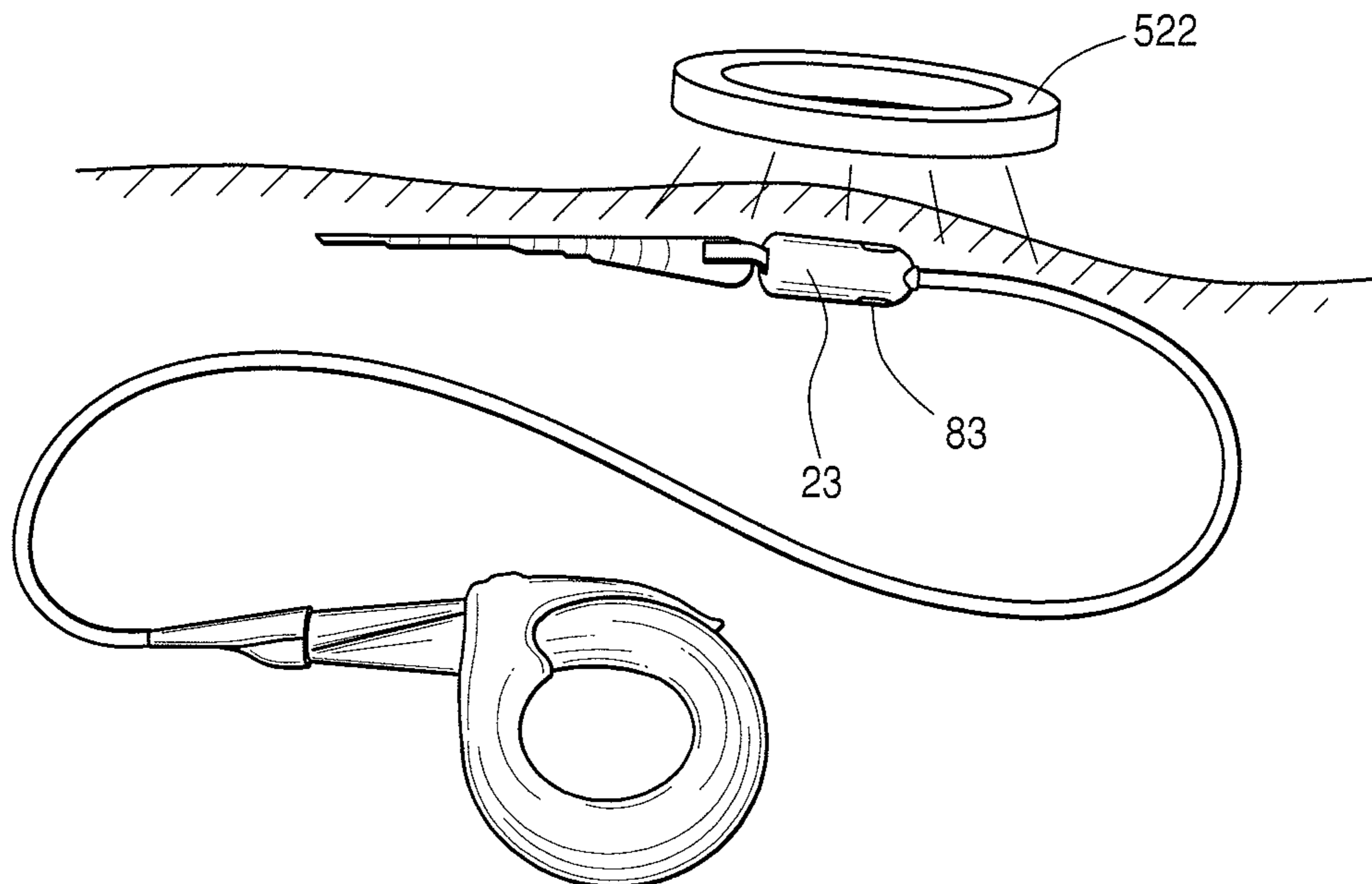

FIG. 81

FIG. 82



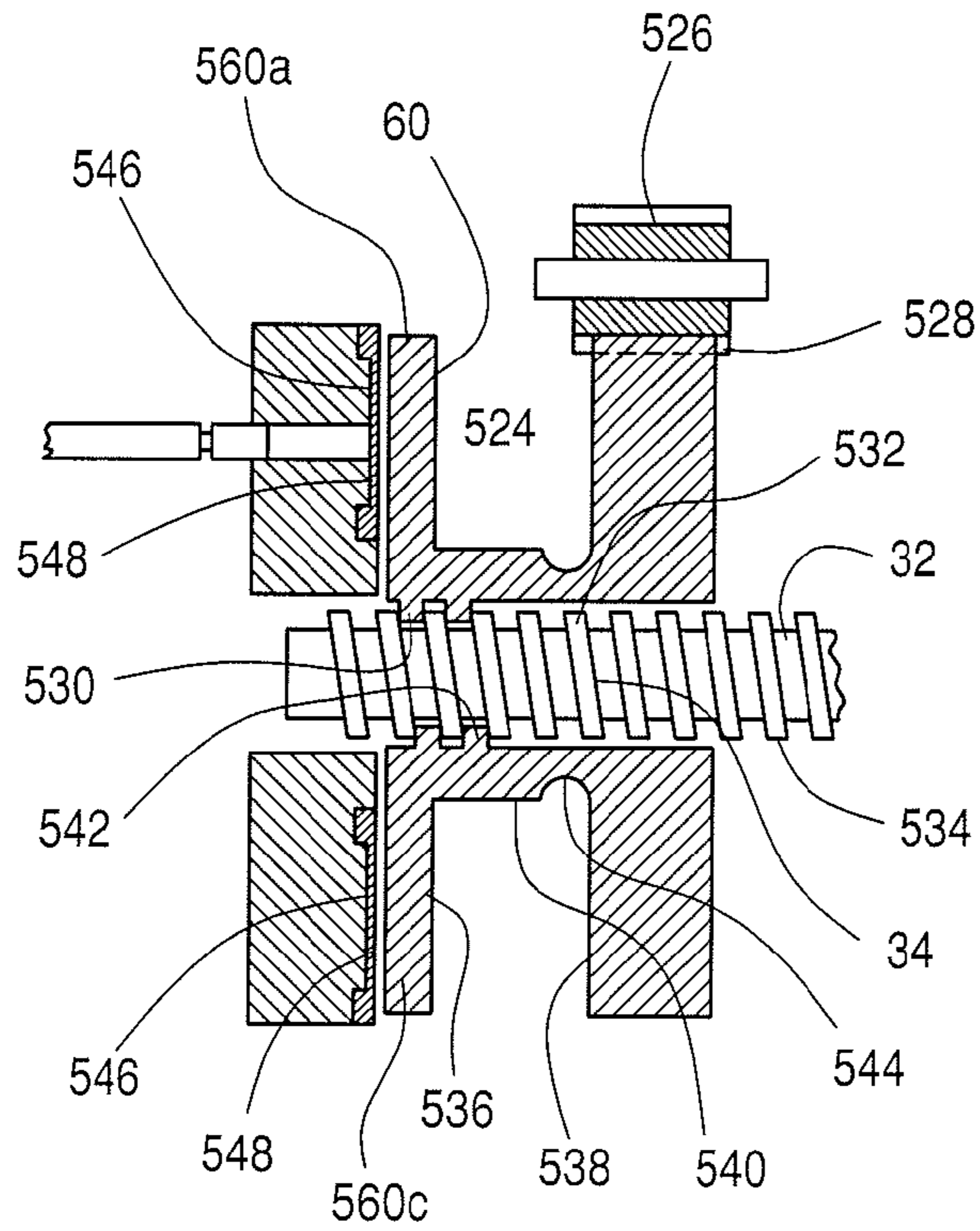

FIG. 83

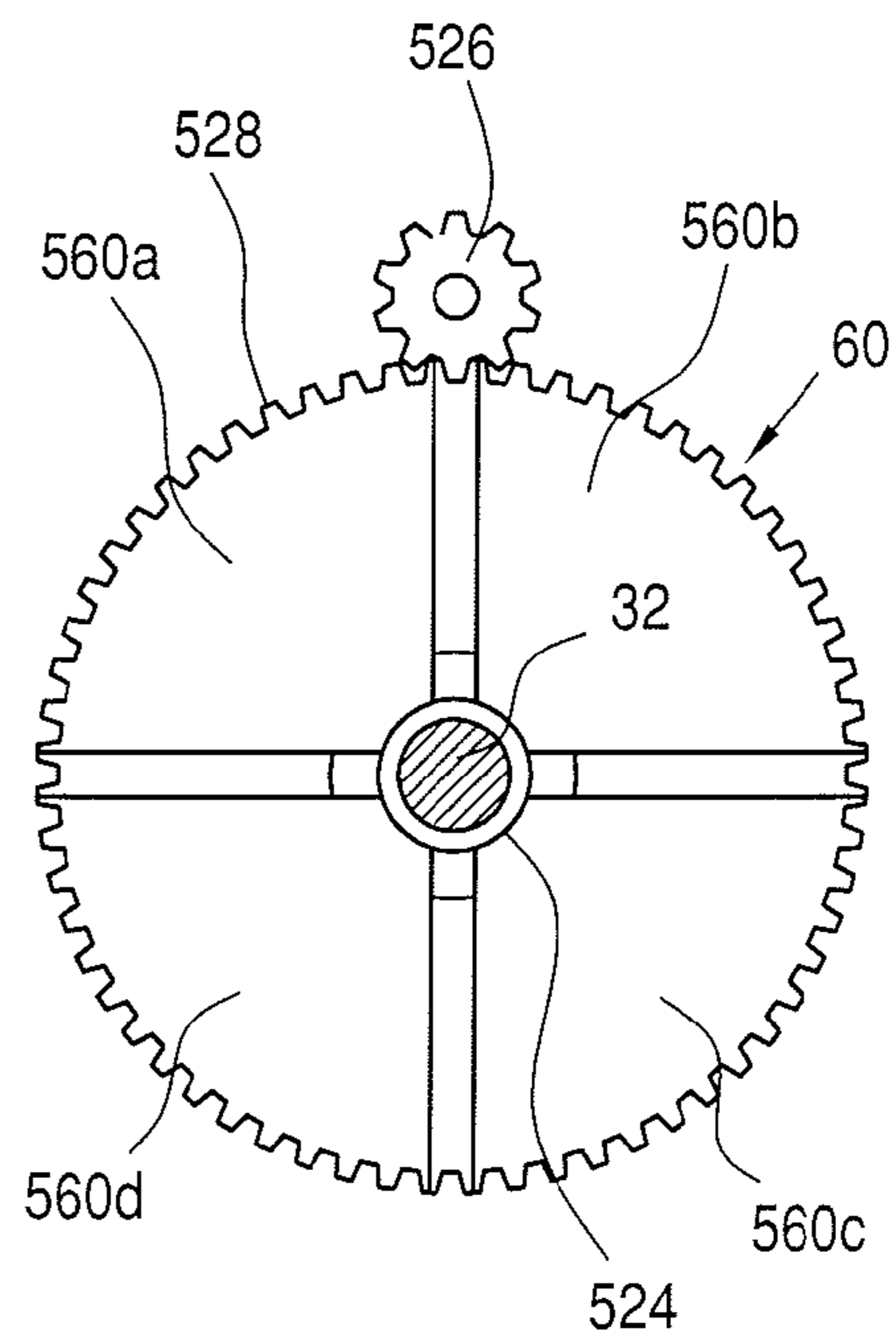

FIG. 84

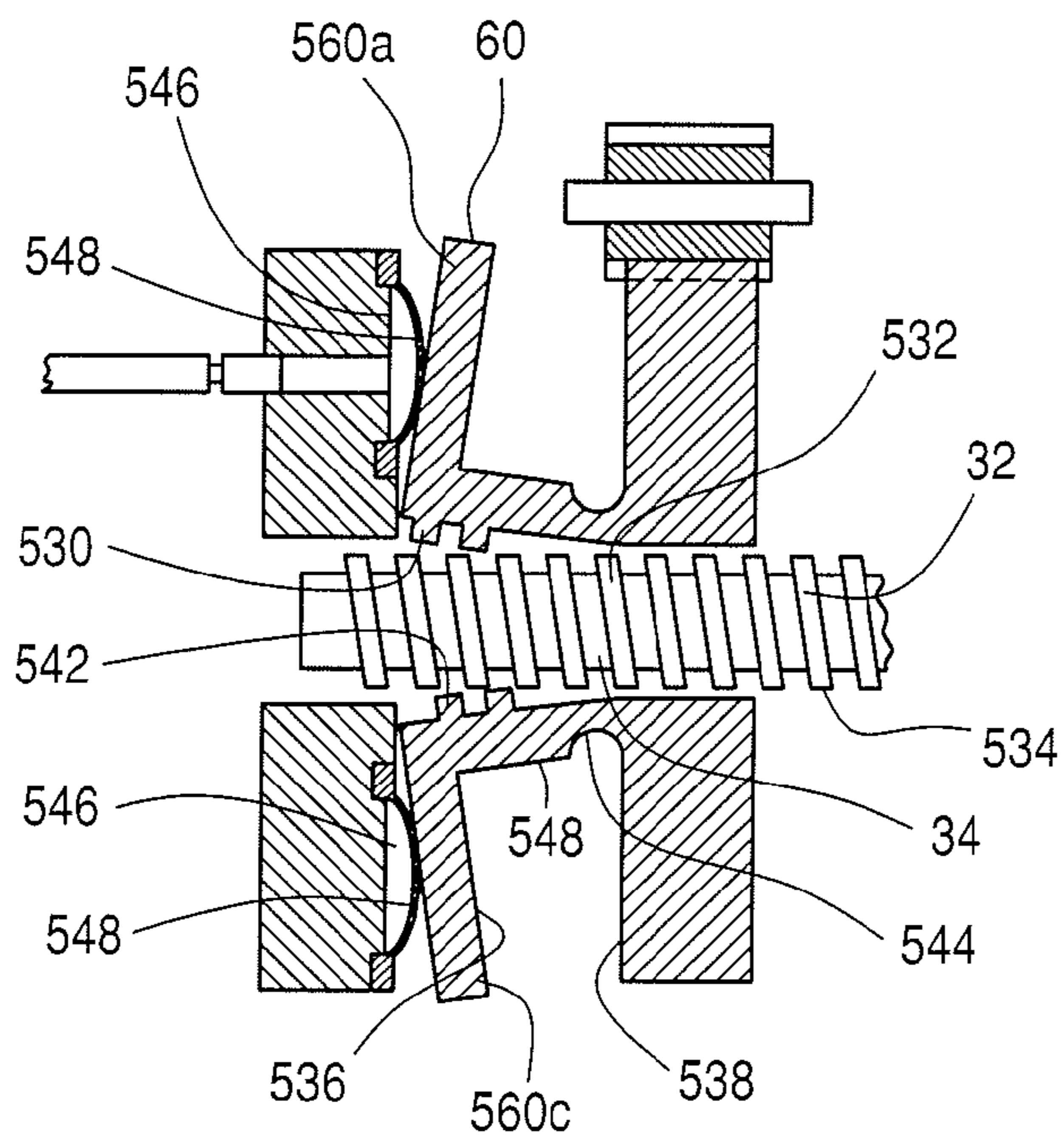

FIG. 85

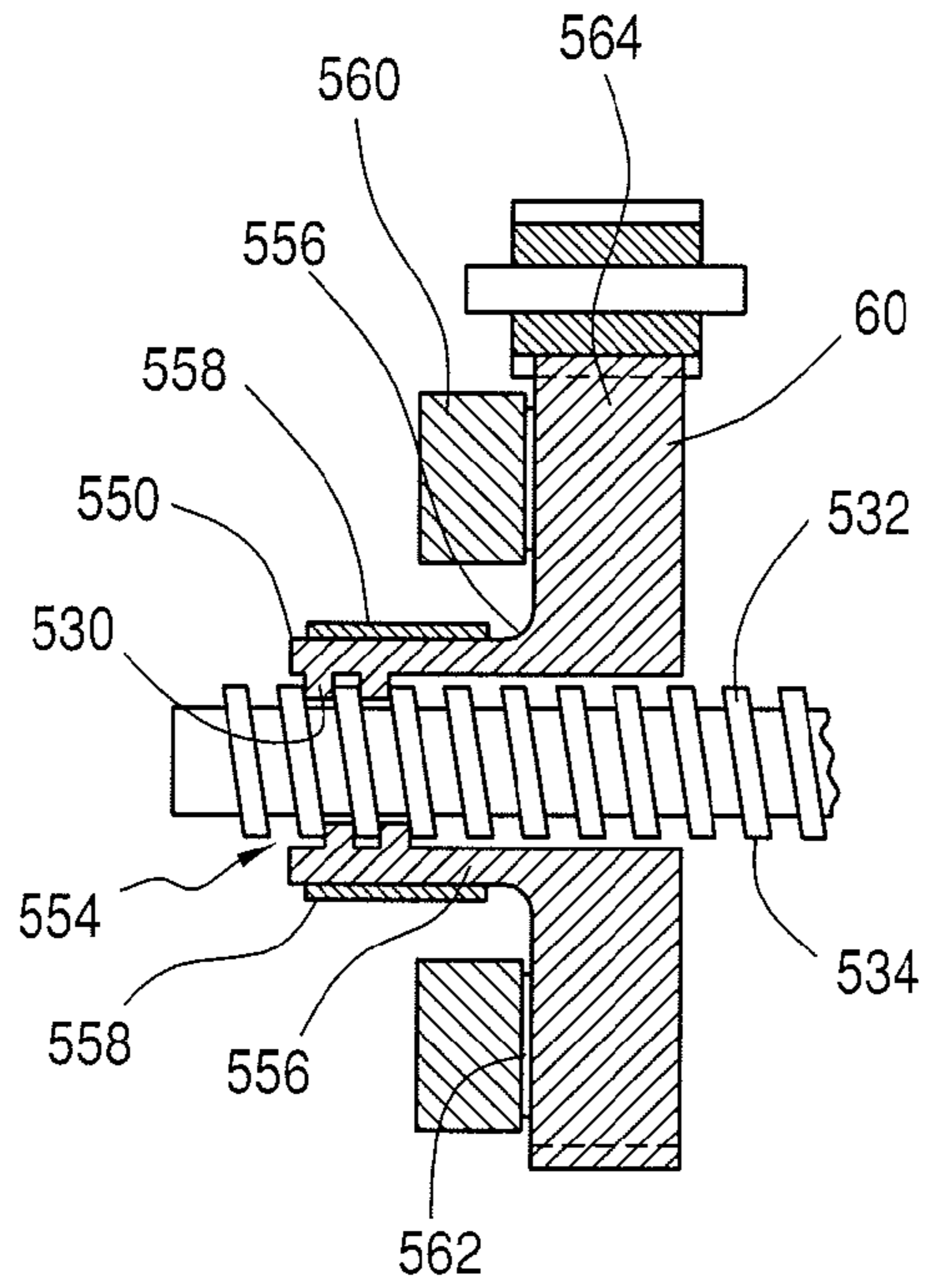

FIG. 86

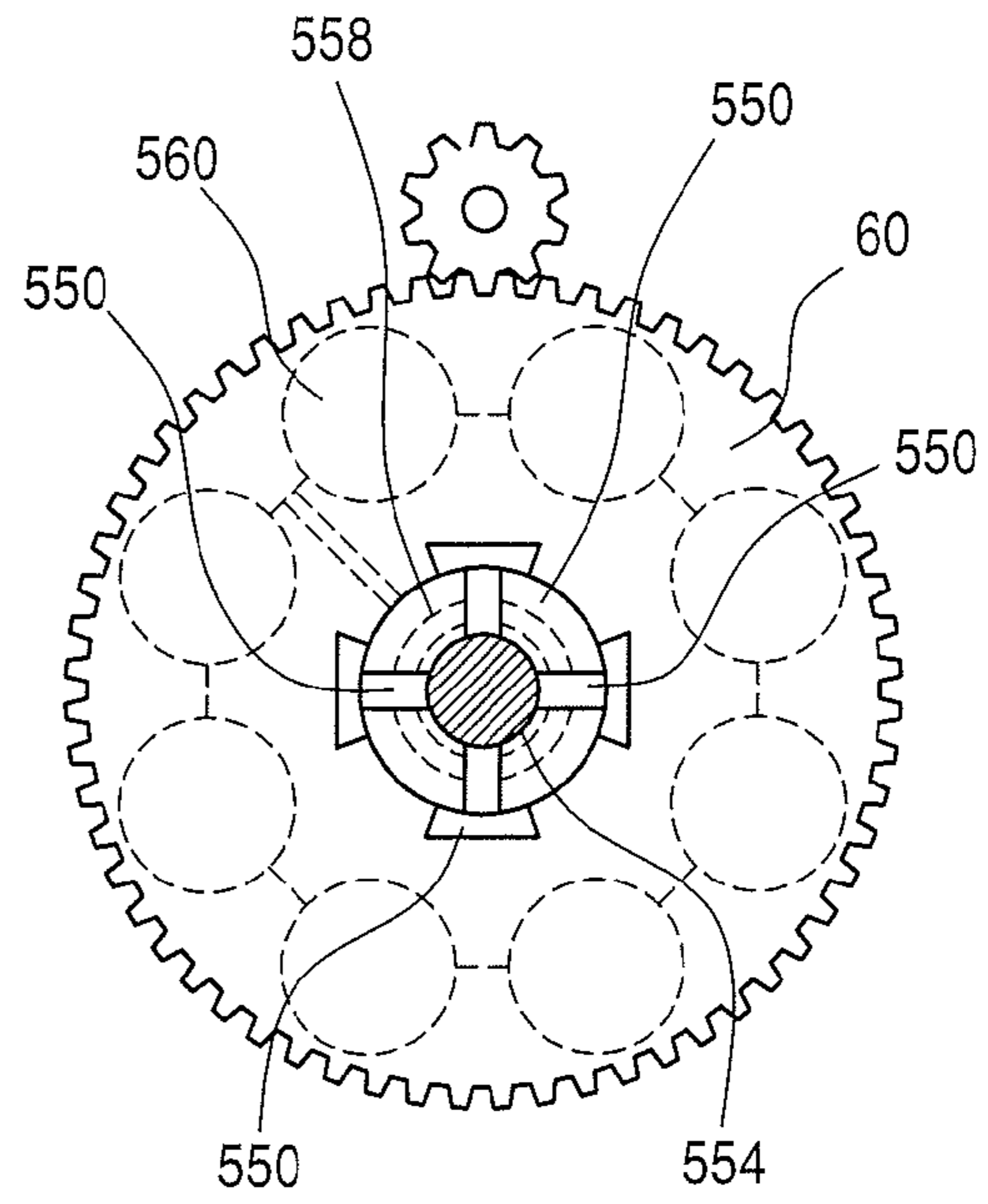

FIG. 87

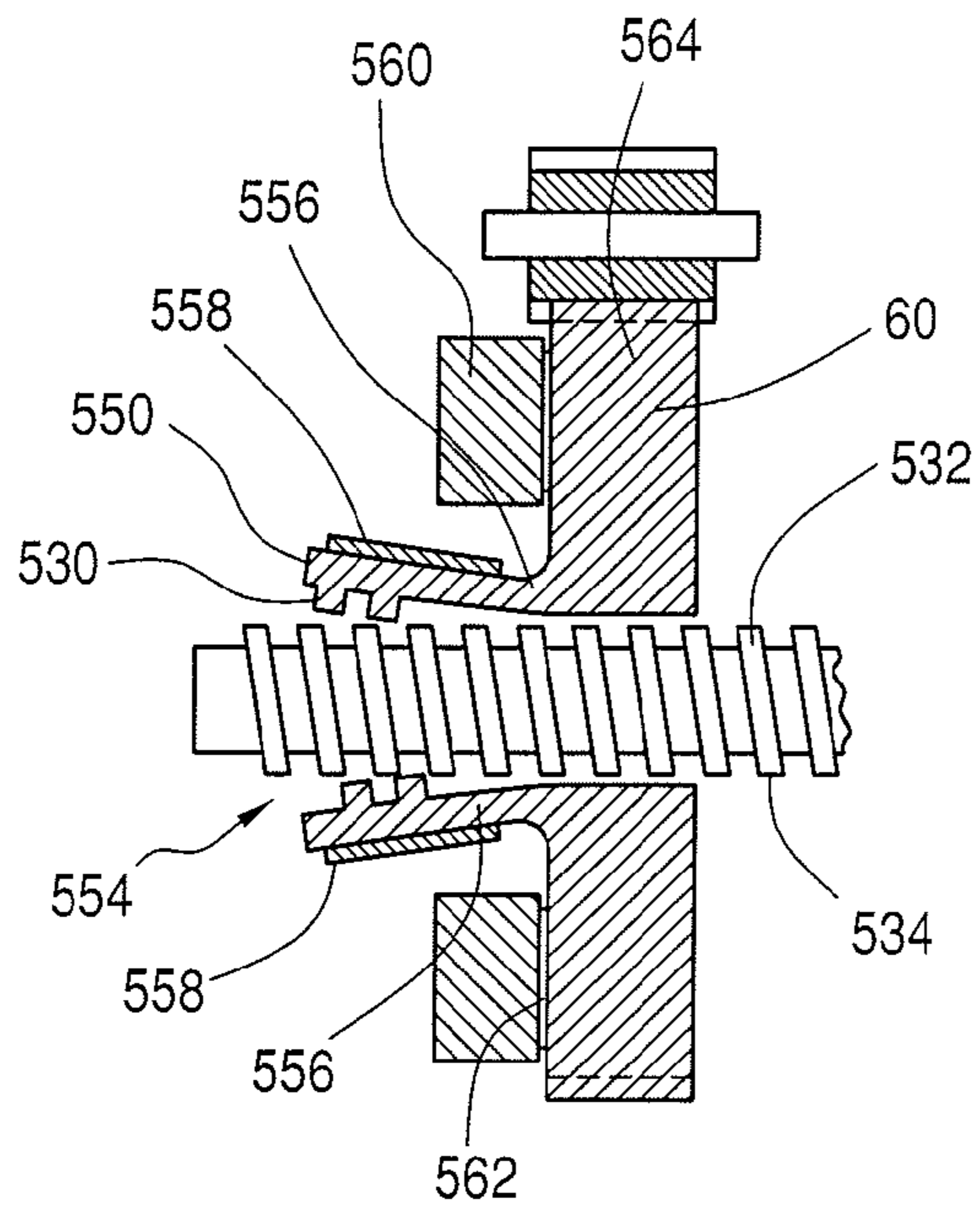

FIG. 88

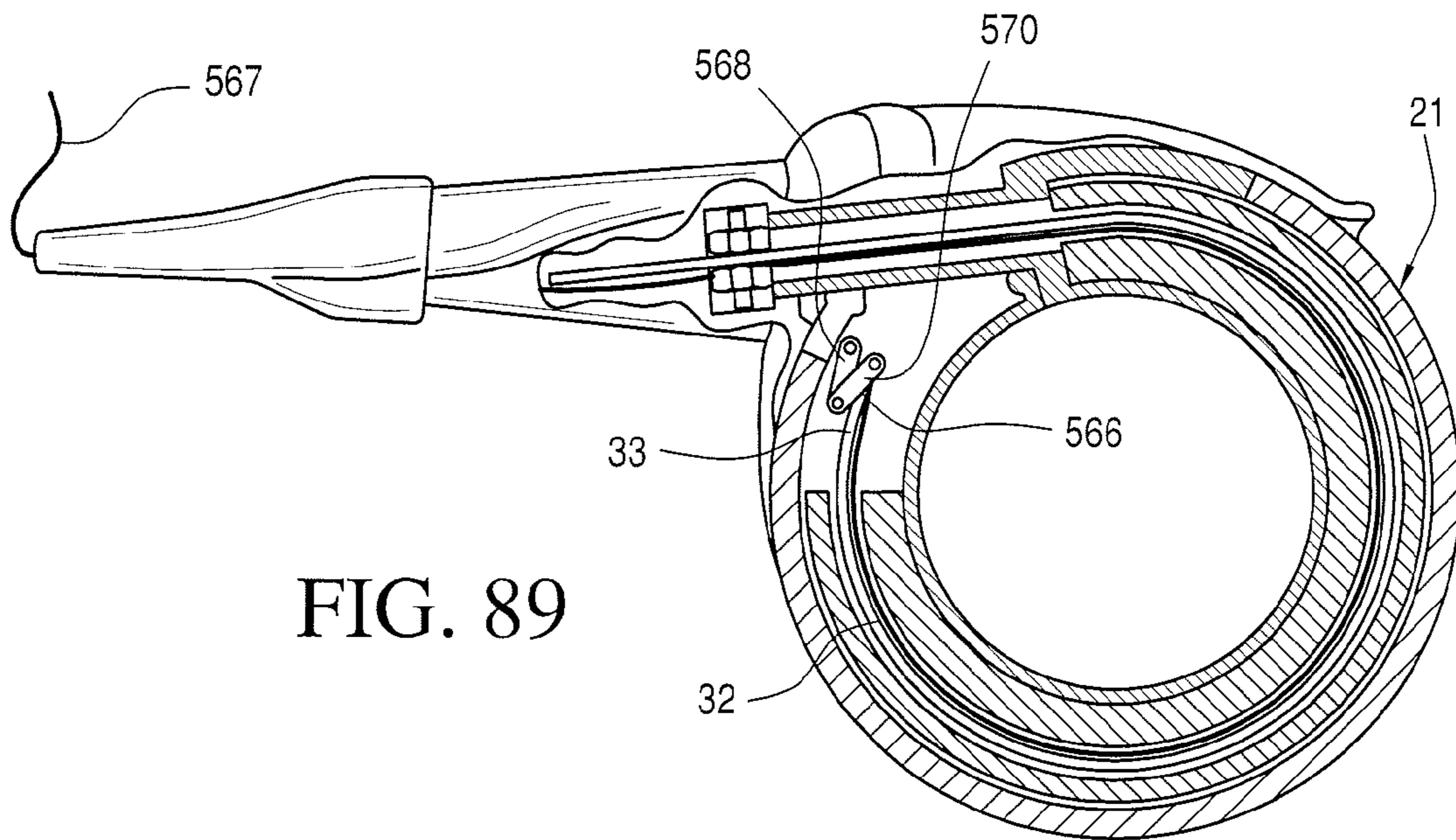

FIG. 89

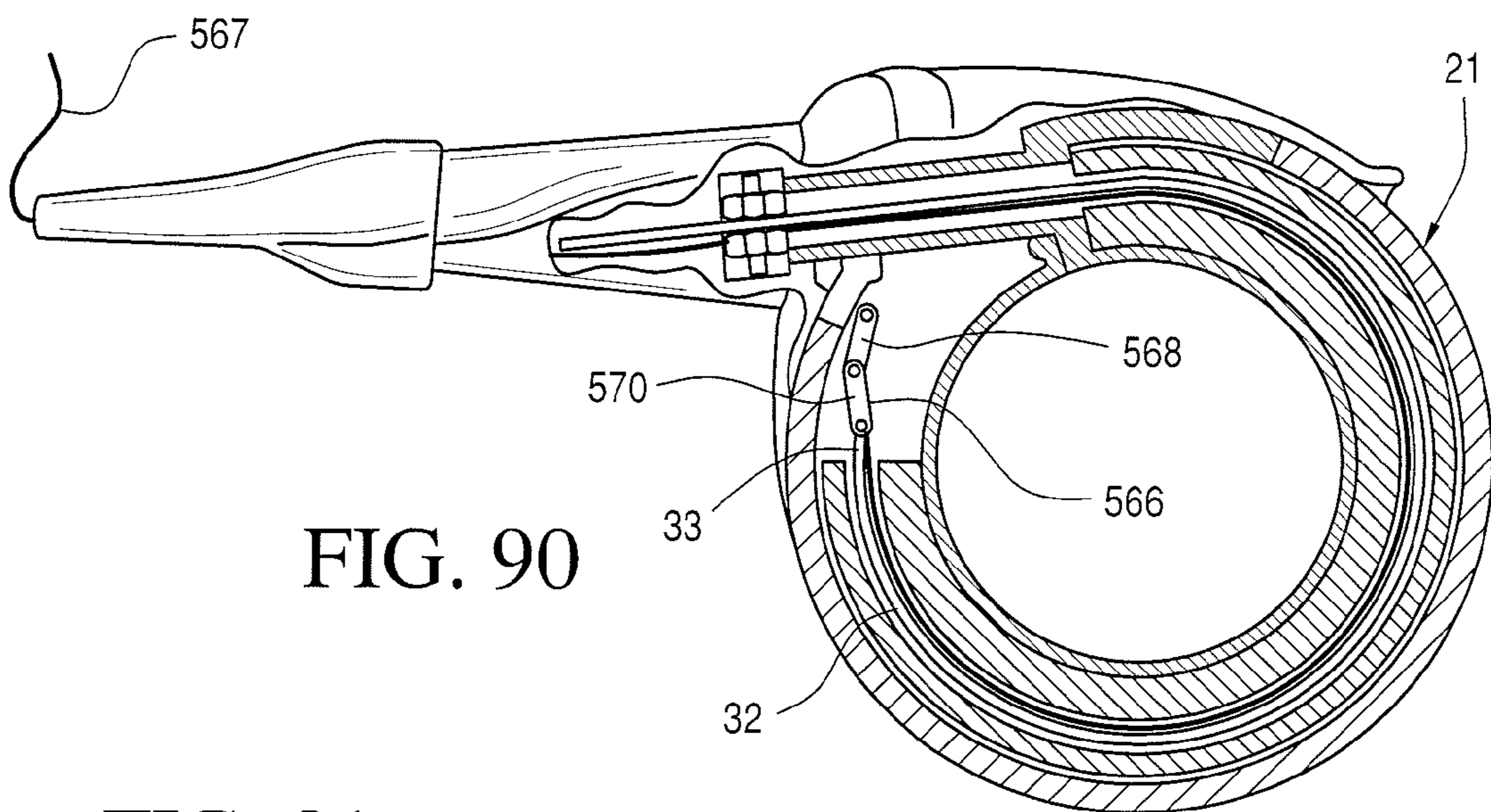
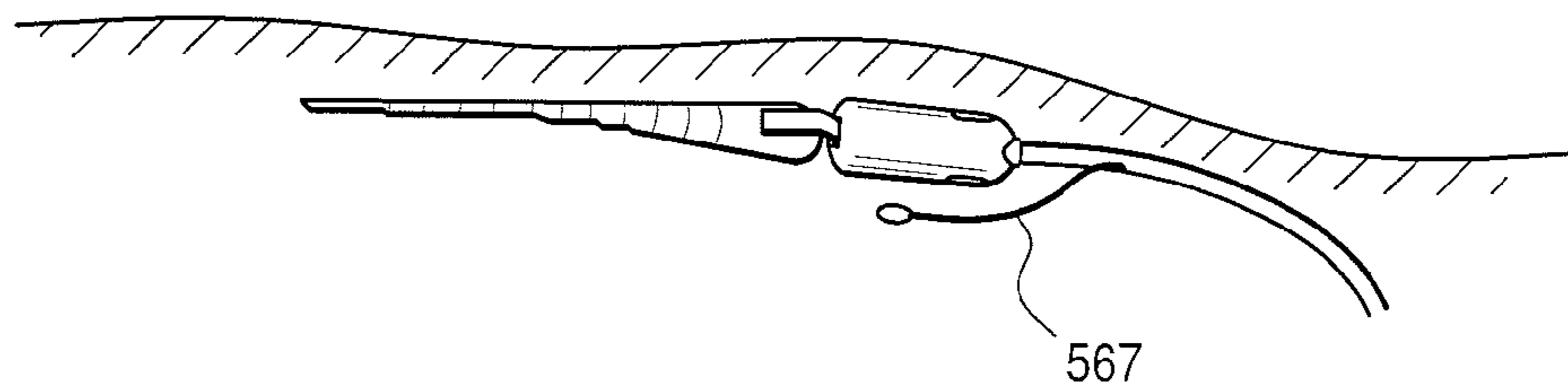

FIG. 90

FIG. 91



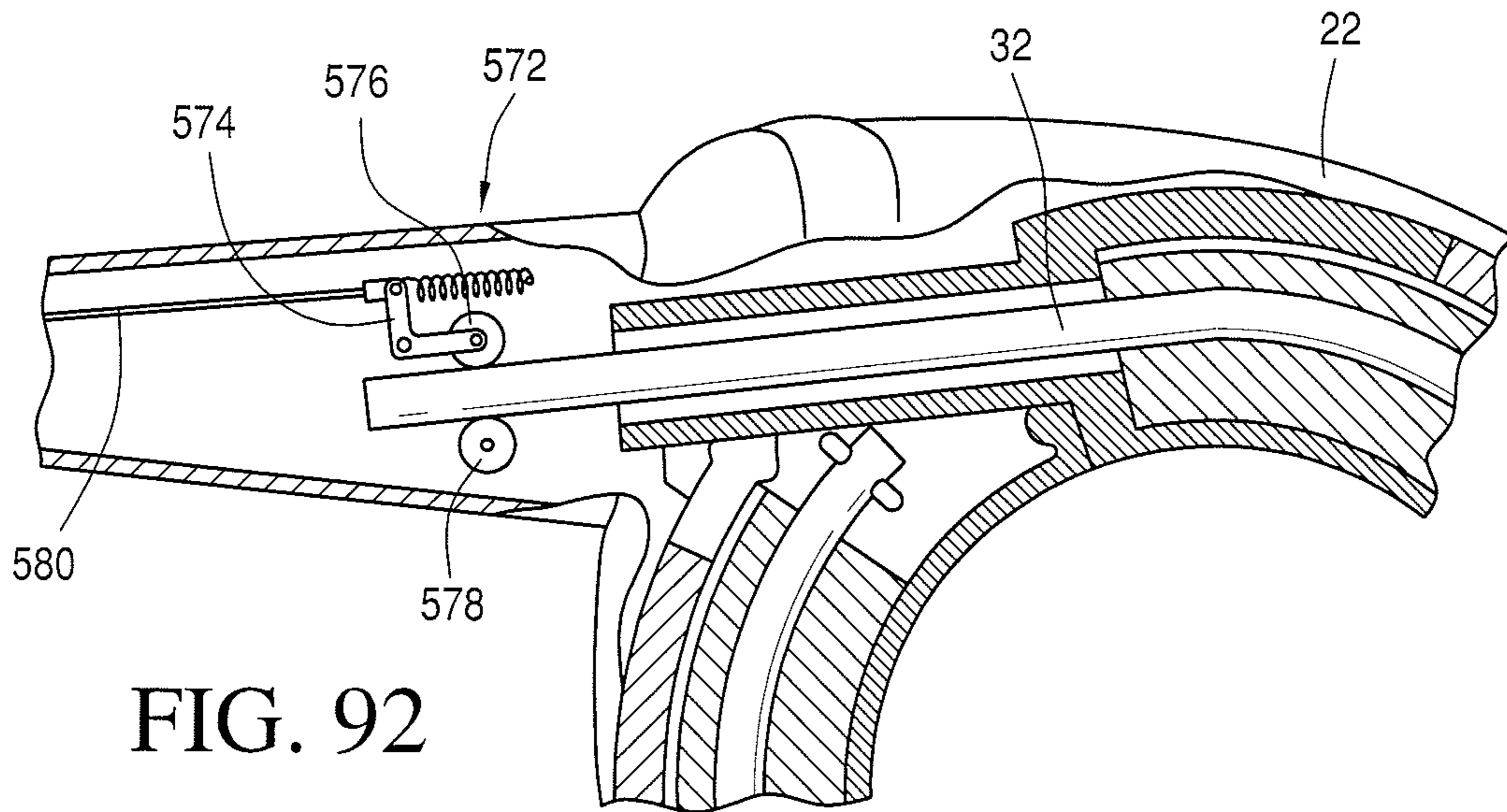

FIG. 92

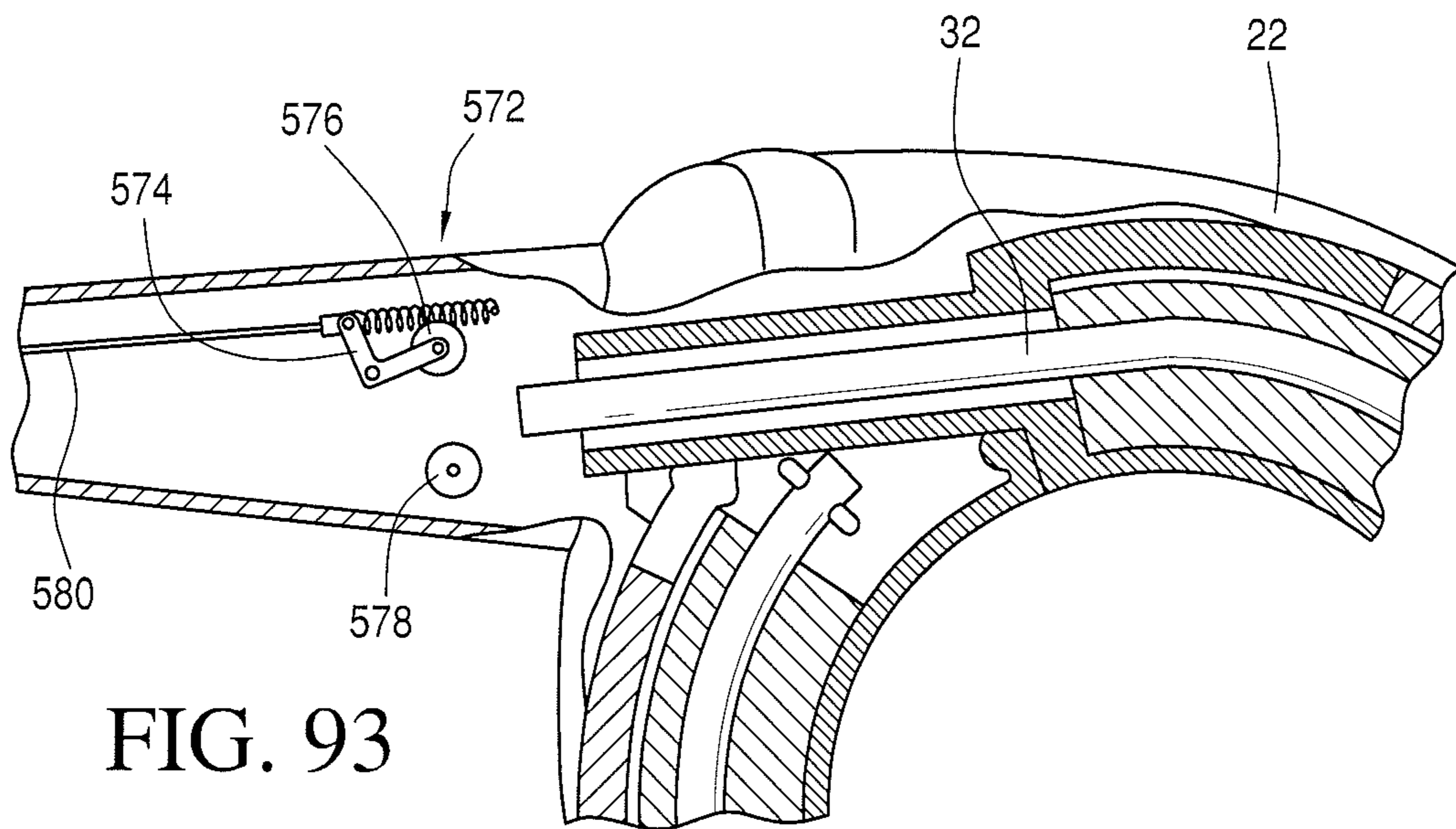

FIG. 93

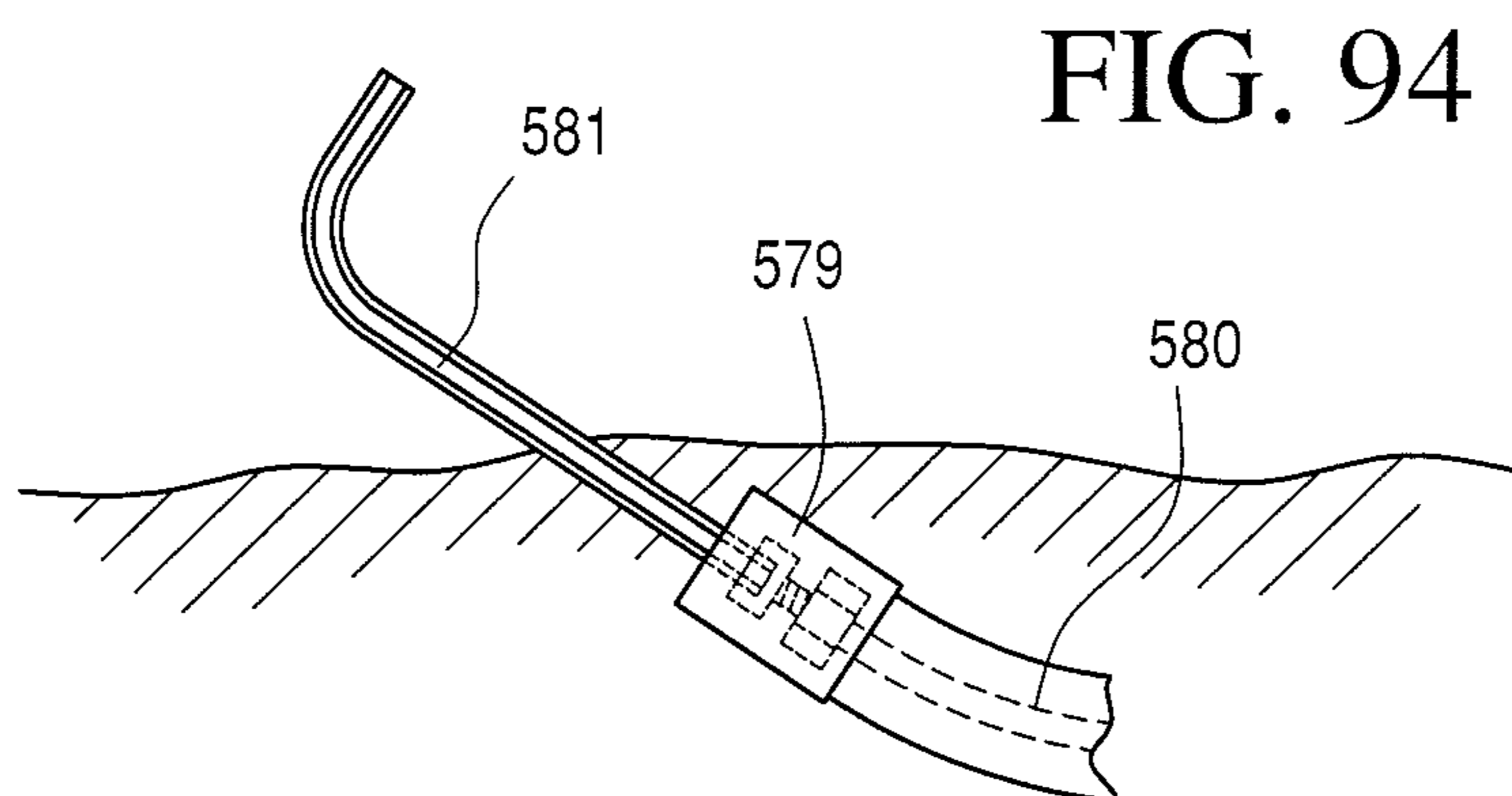

FIG. 94

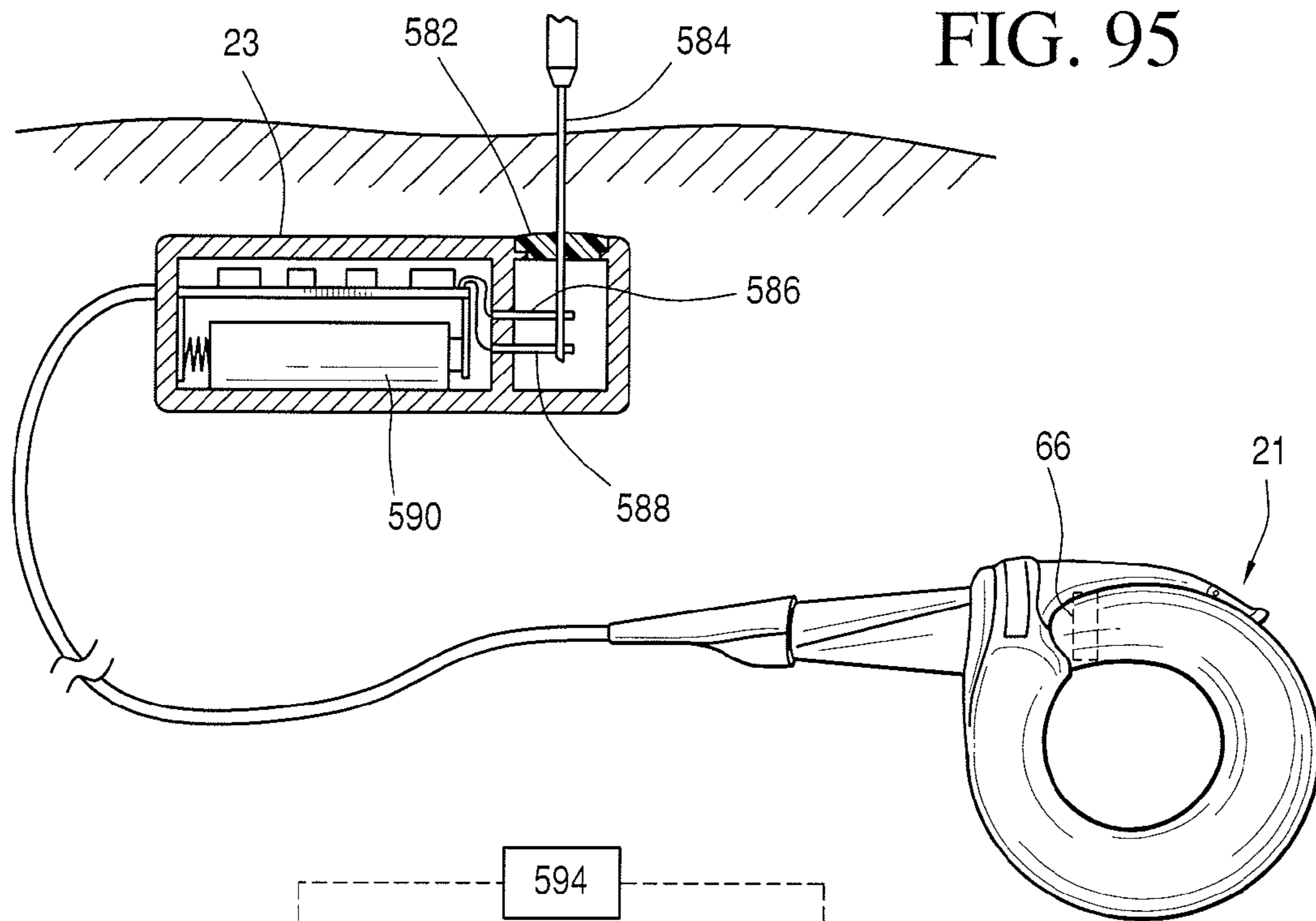

FIG. 95

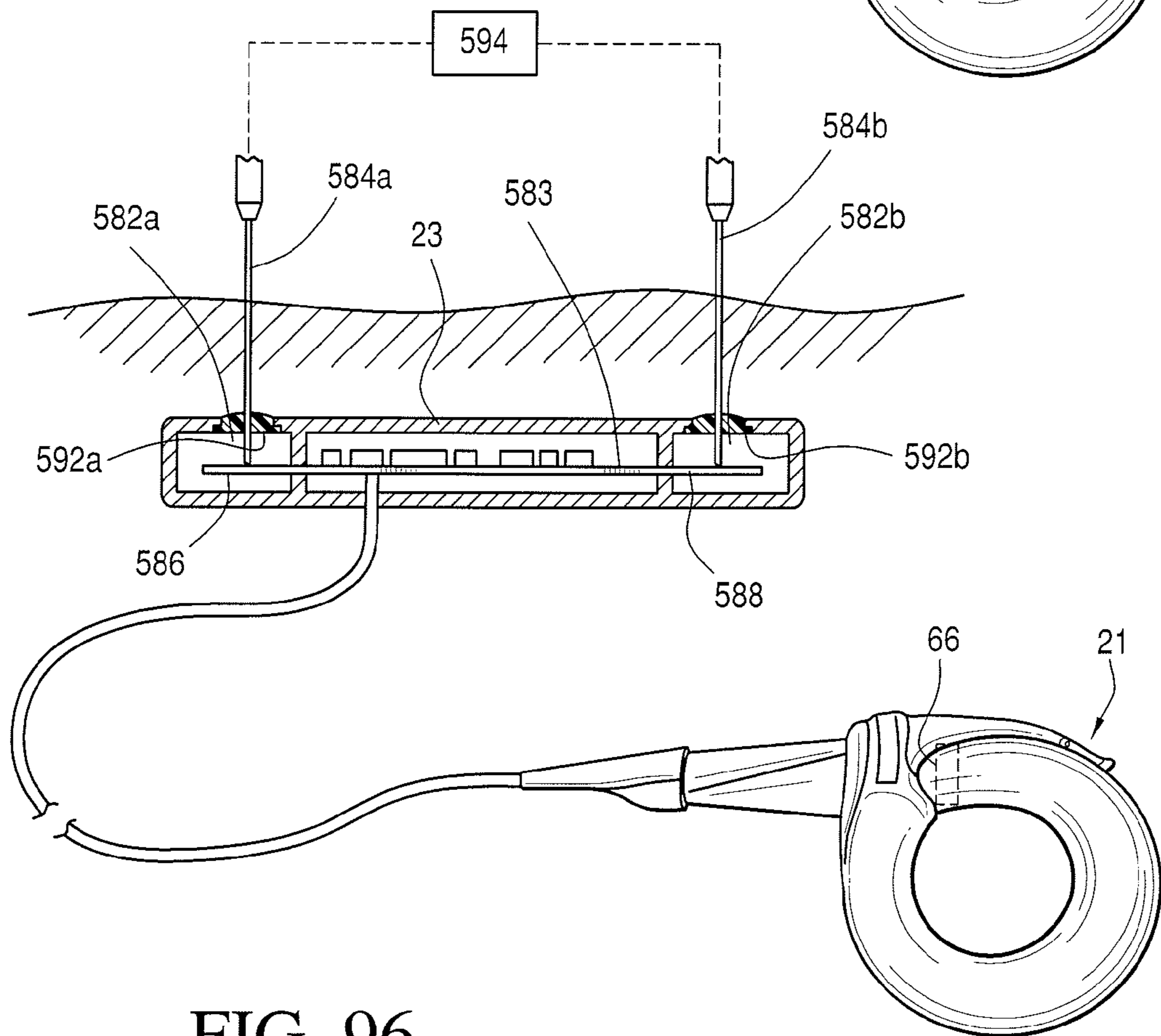

FIG. 96

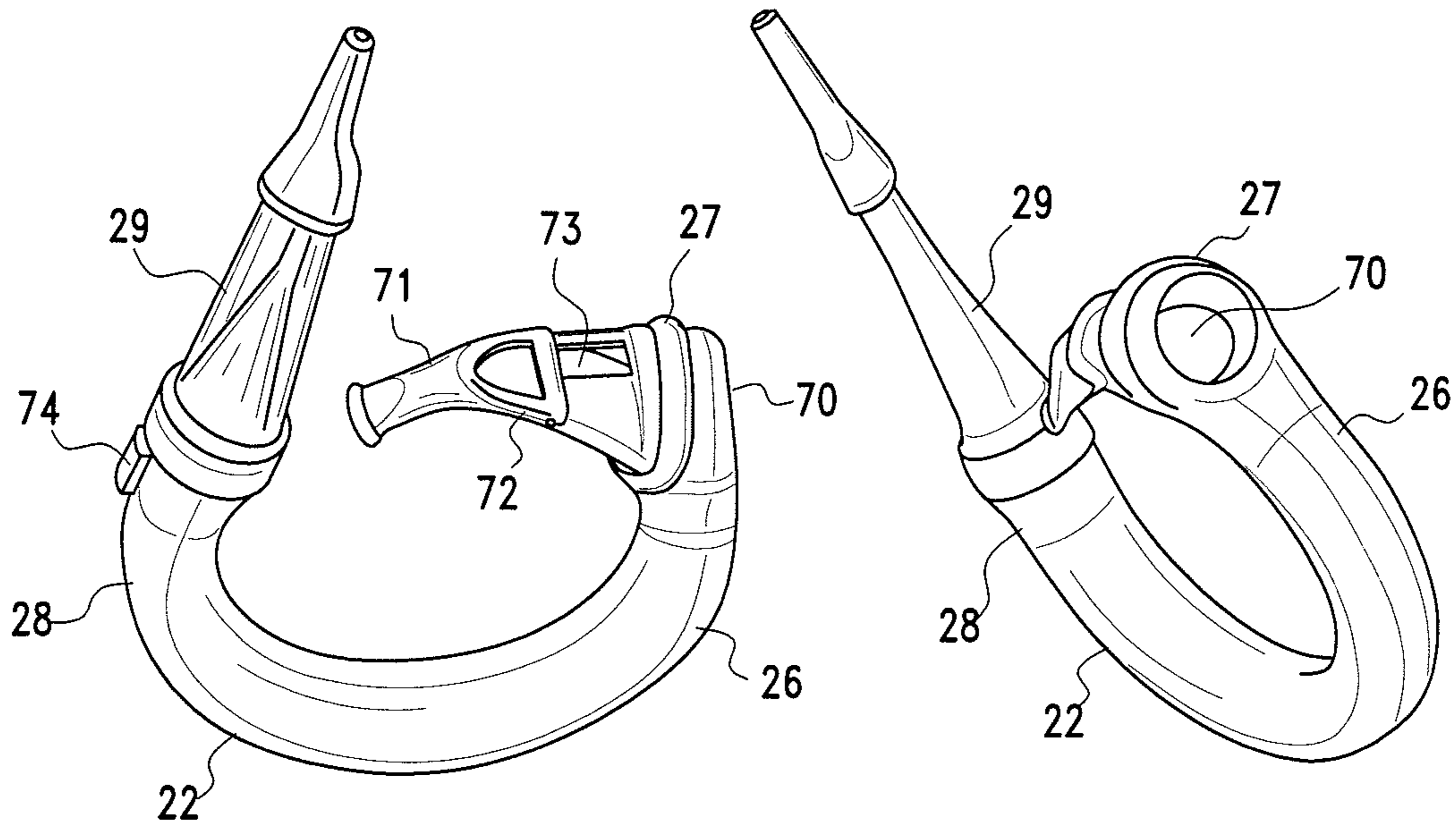

FIG. 97A

FIG. 97B

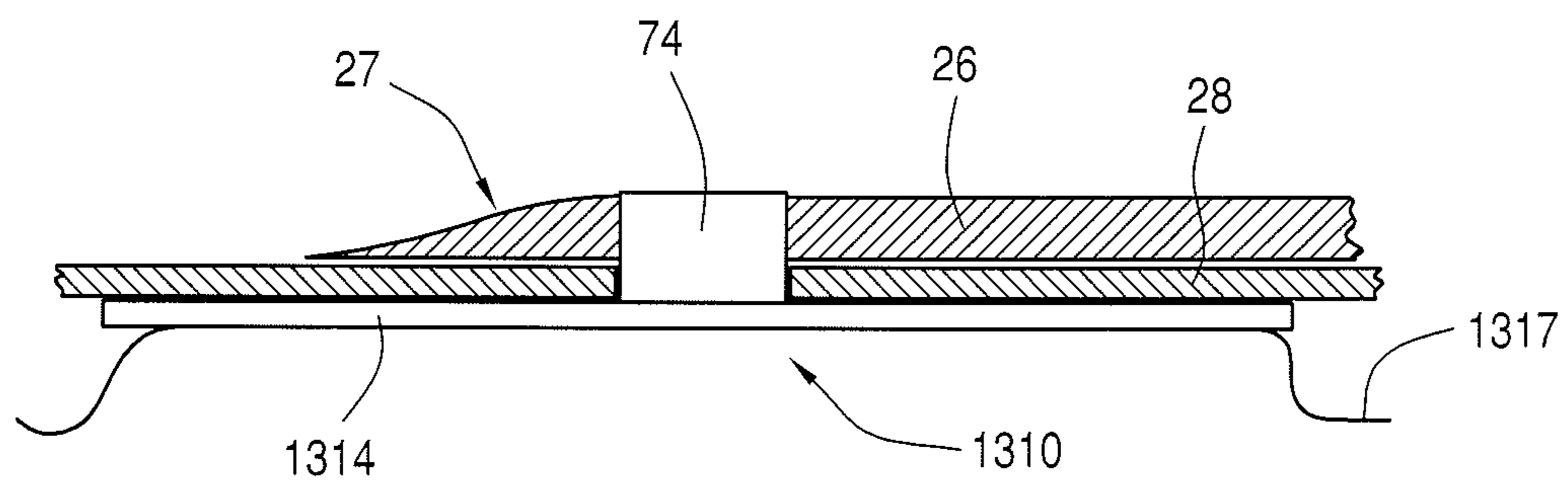

FIG. 98

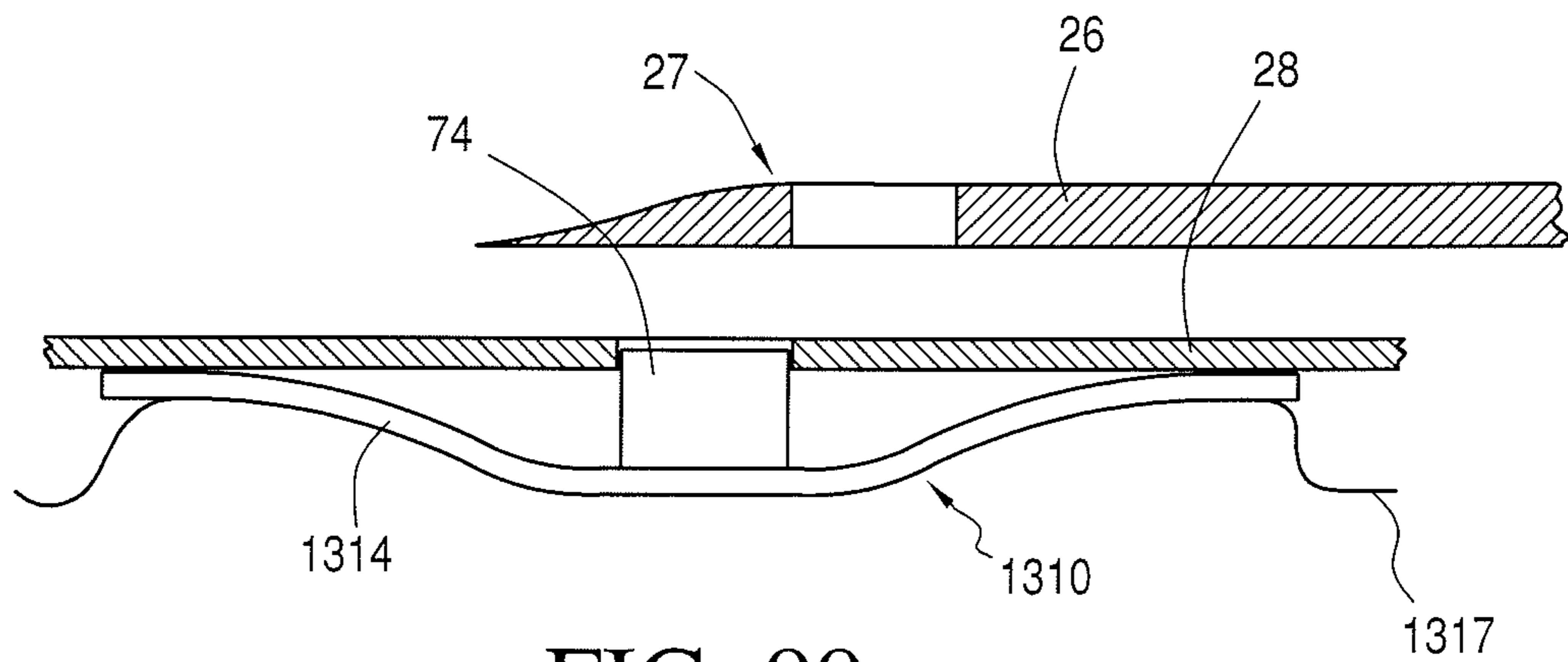

FIG. 99

FIG. 100

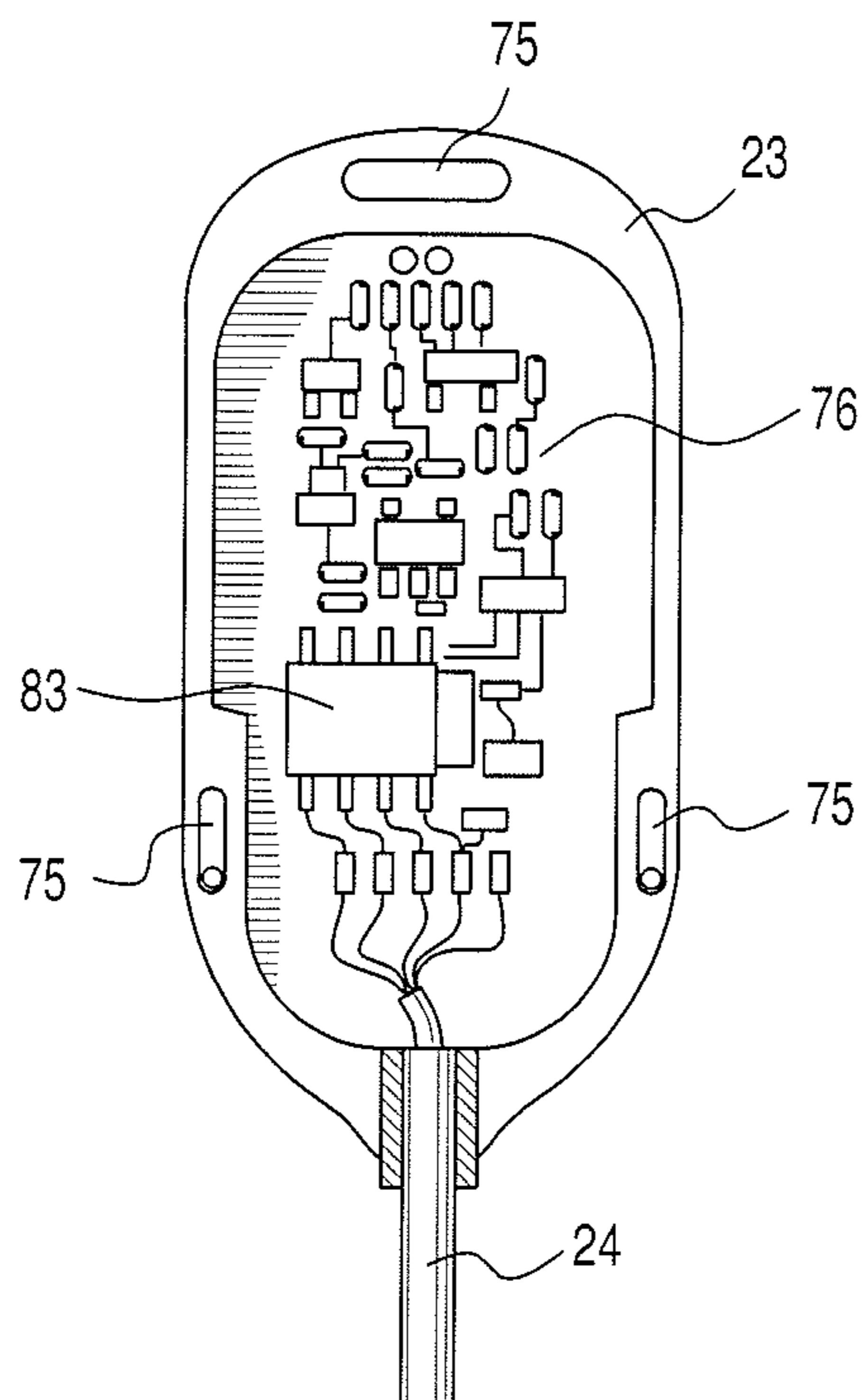
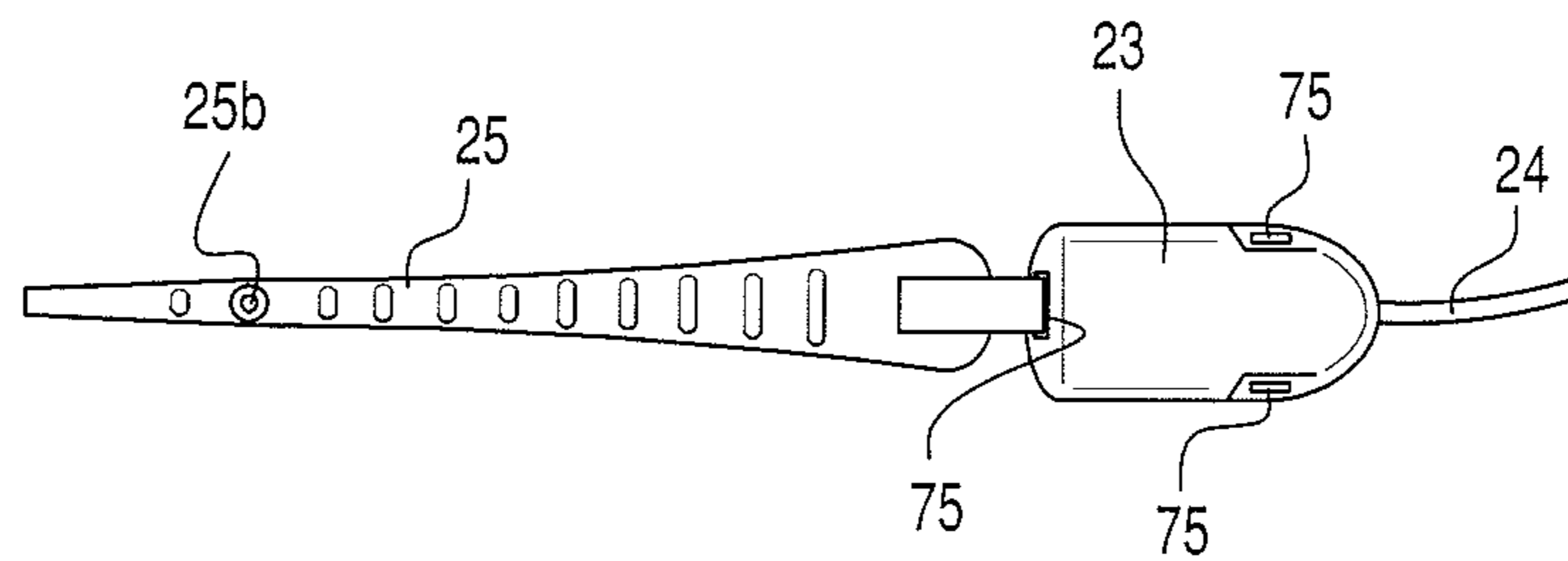

FIG. 101

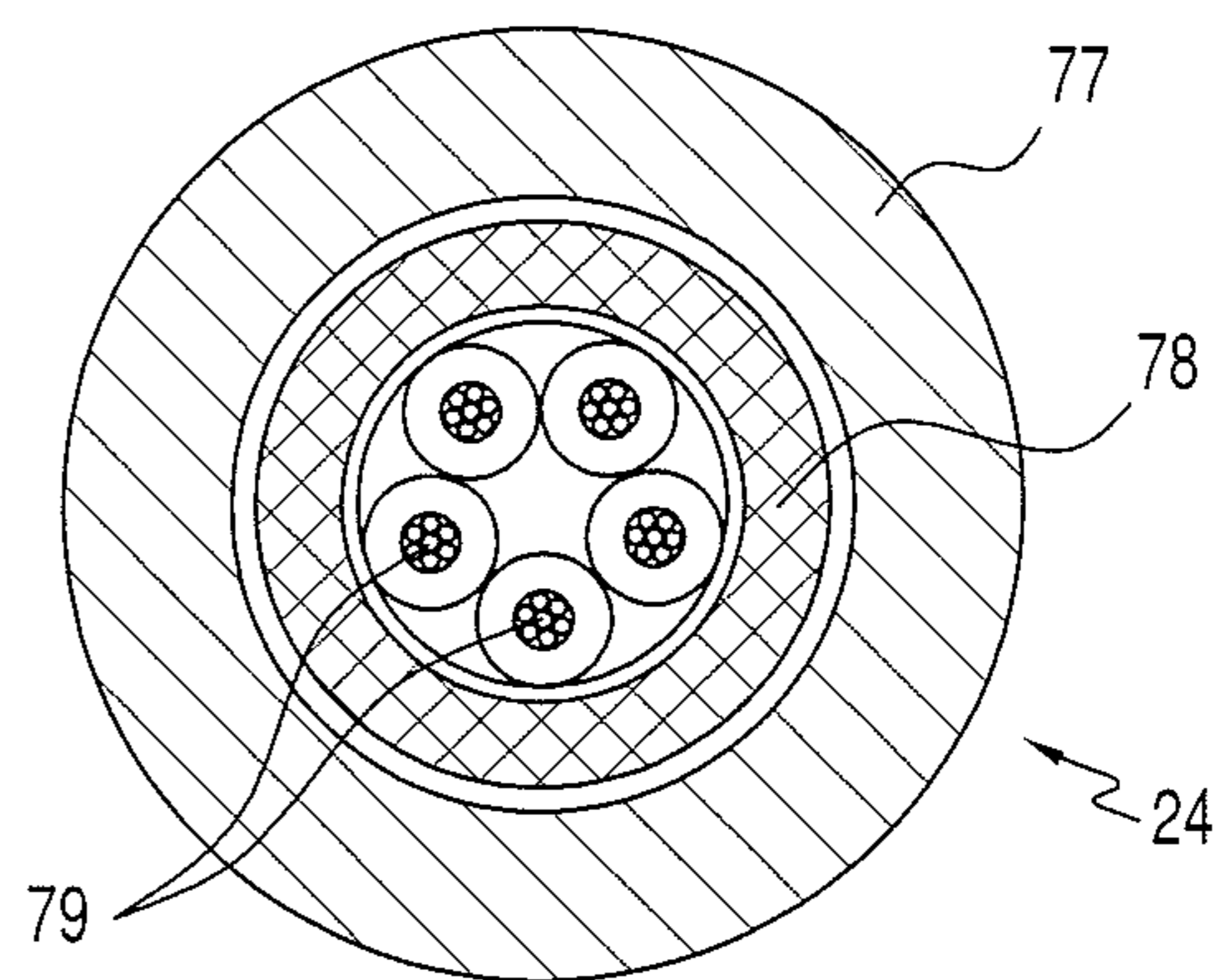

FIG. 102

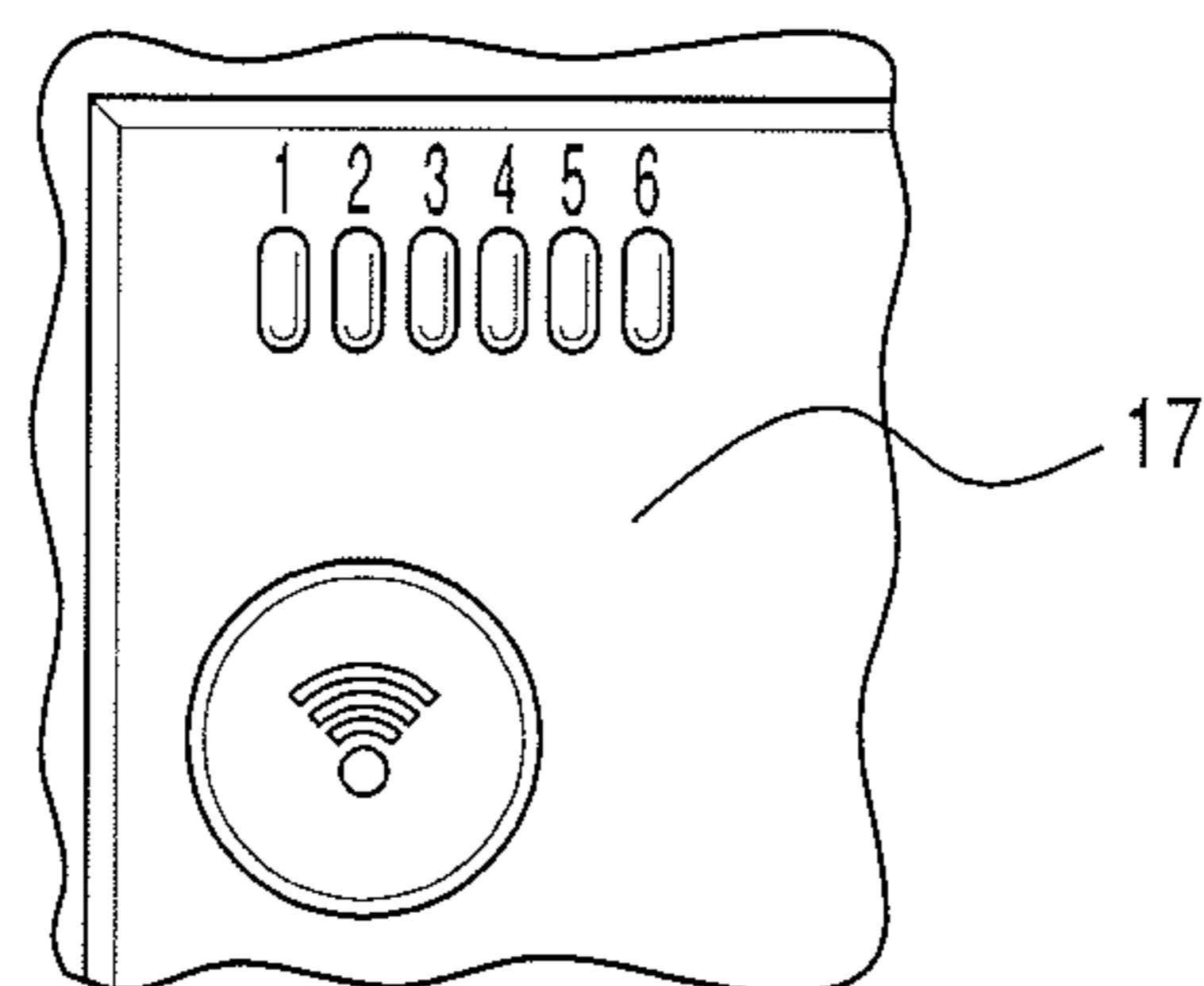

FIG. 103

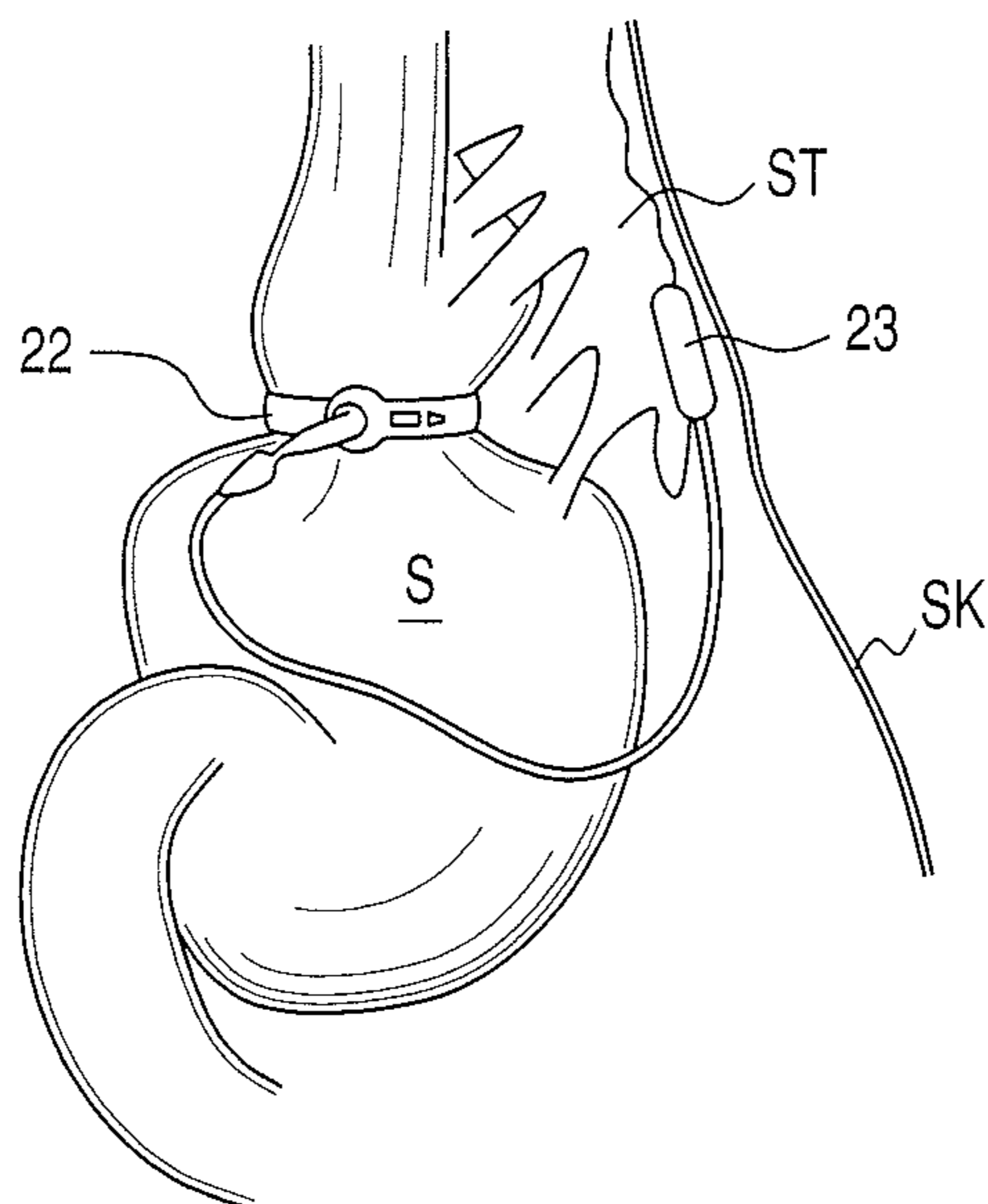
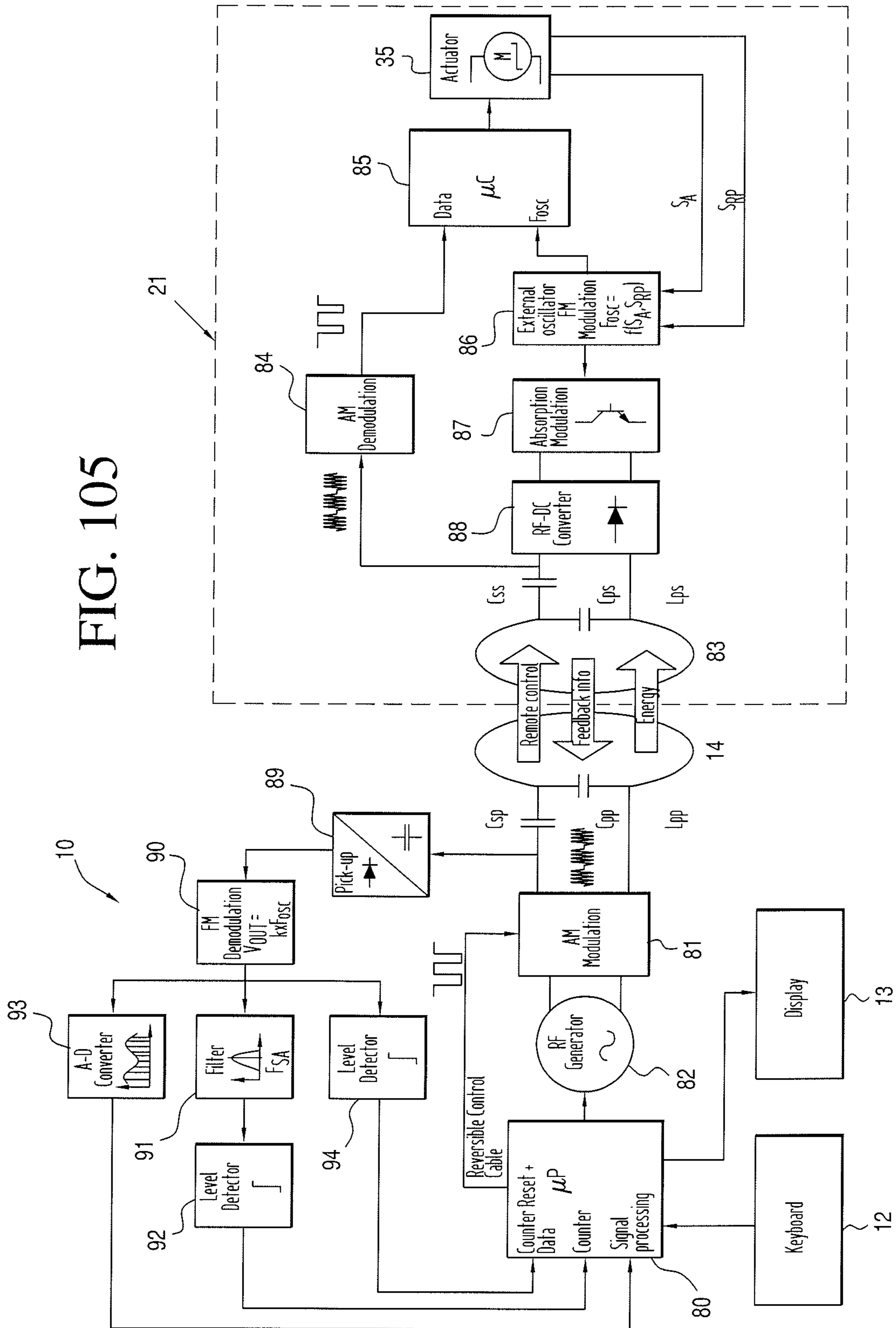

FIG. 104



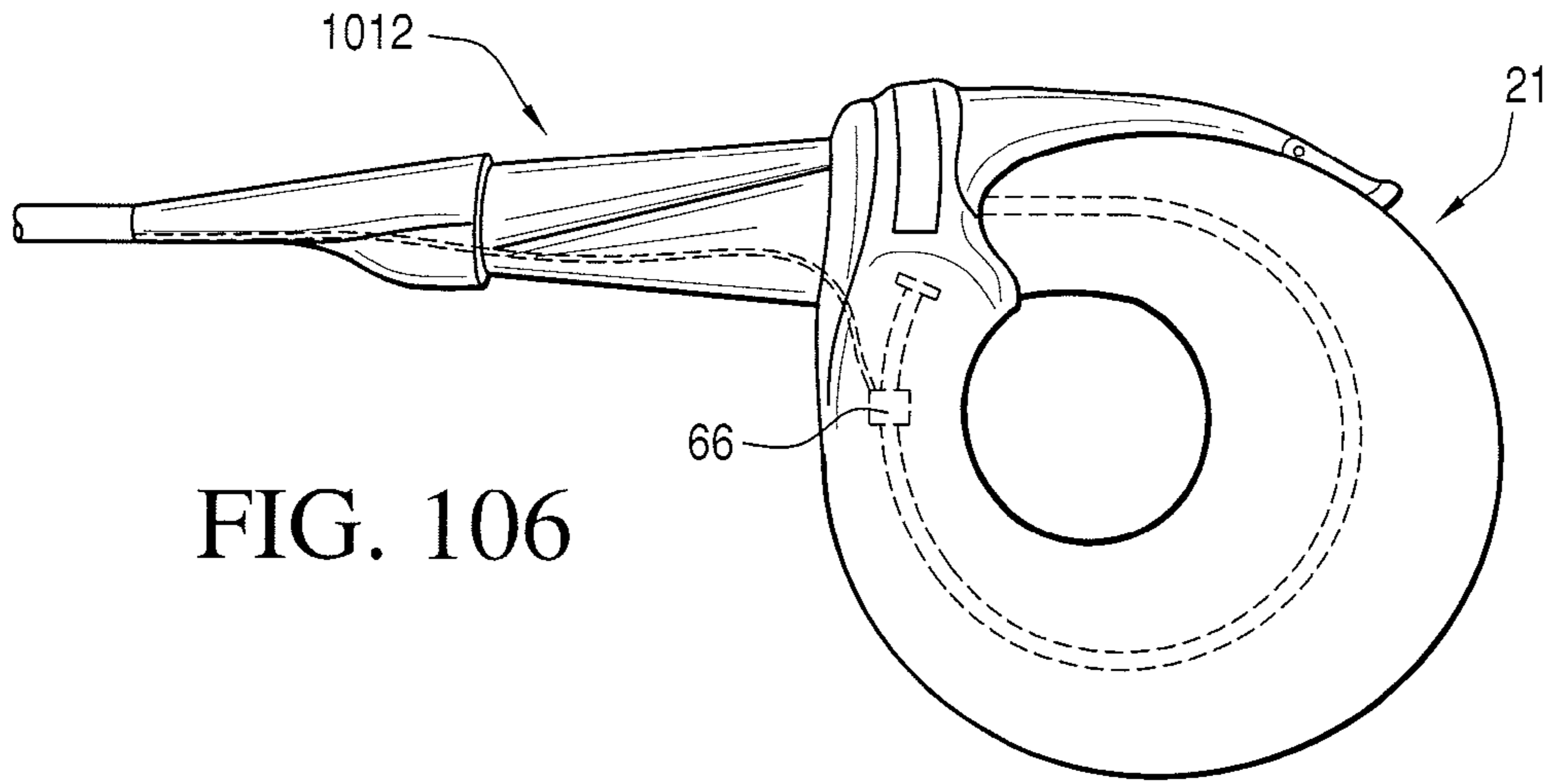

FIG. 106

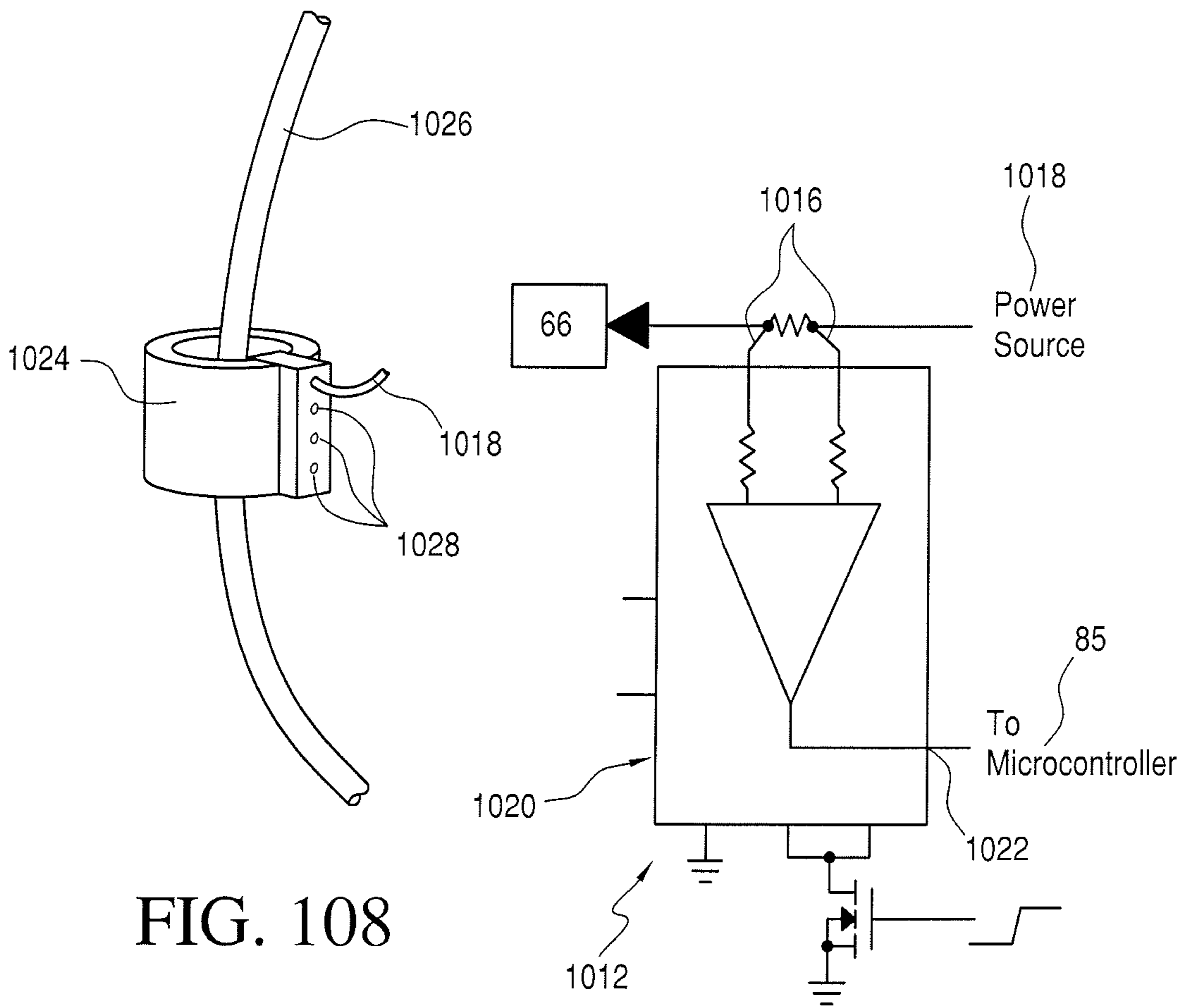

FIG. 108

FIG. 107

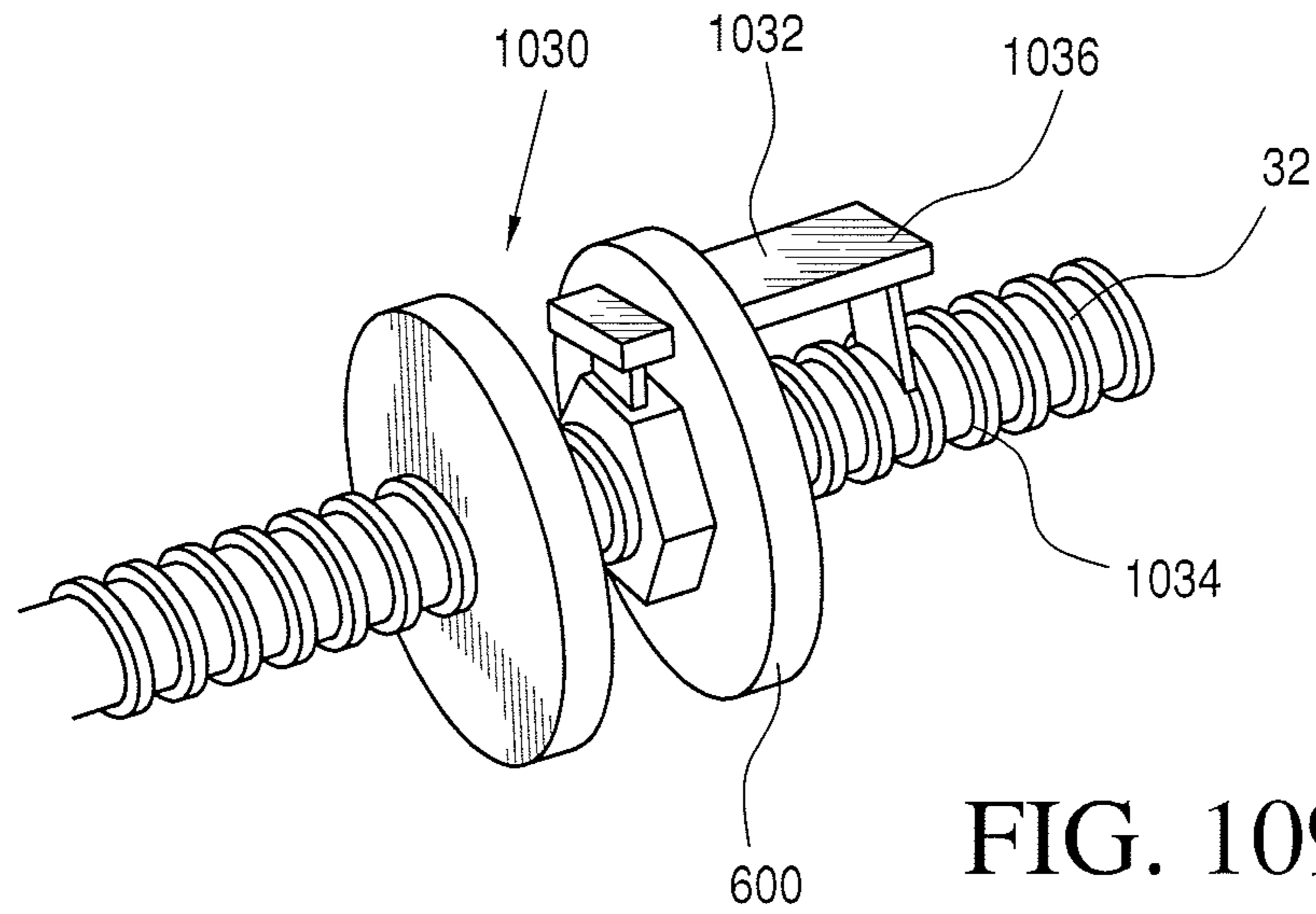

FIG. 109

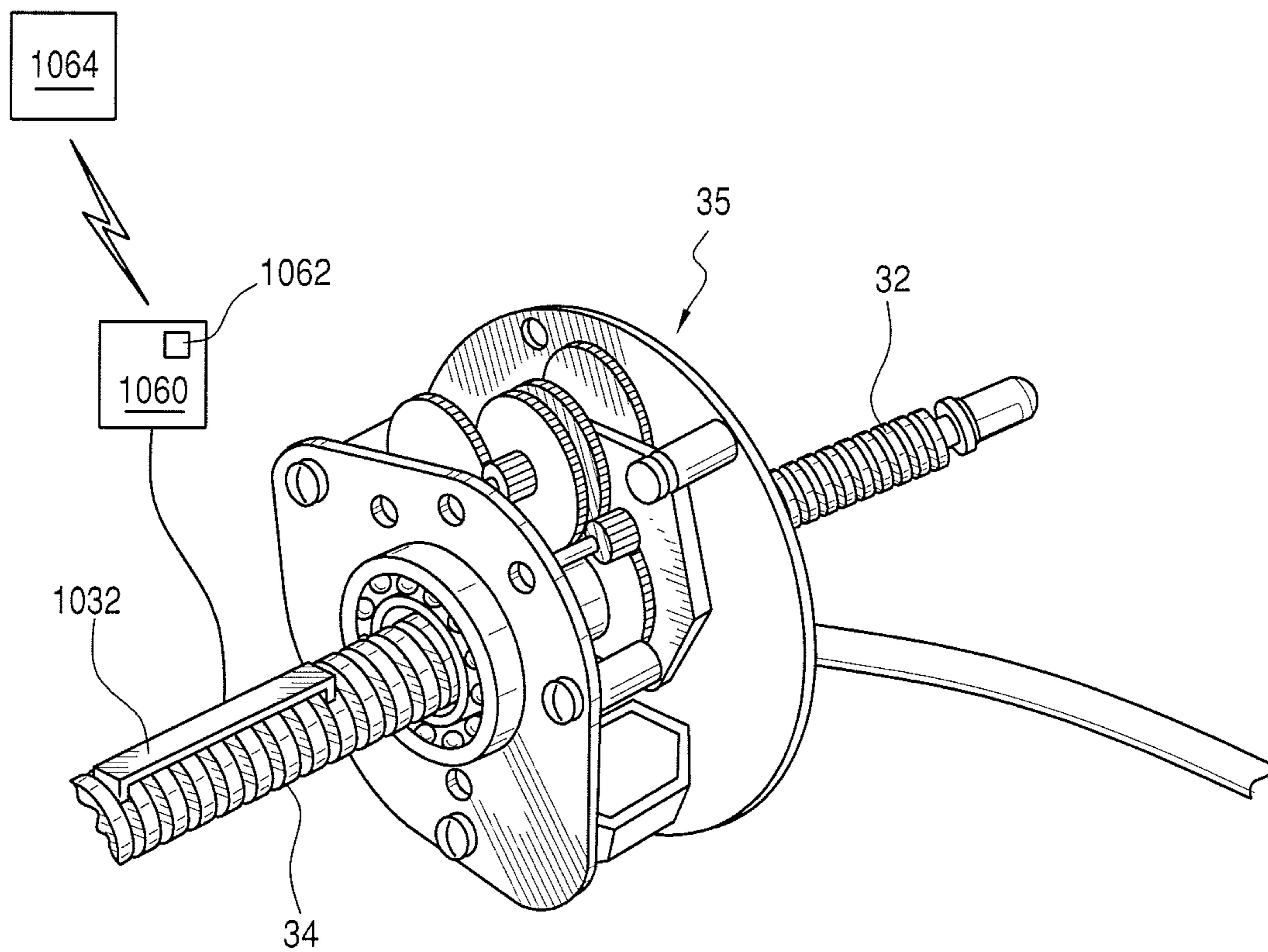

FIG. 110

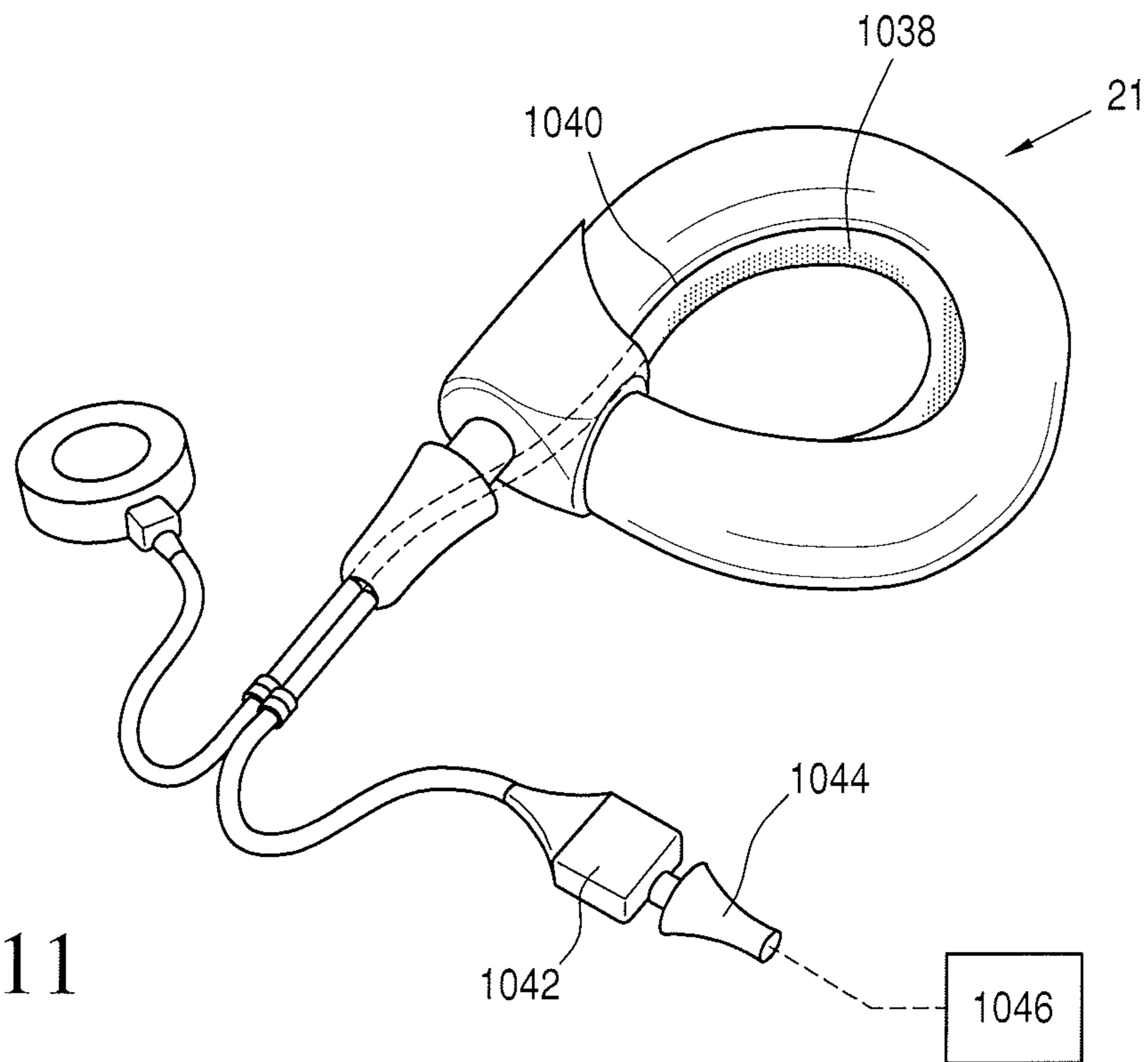

FIG. 111

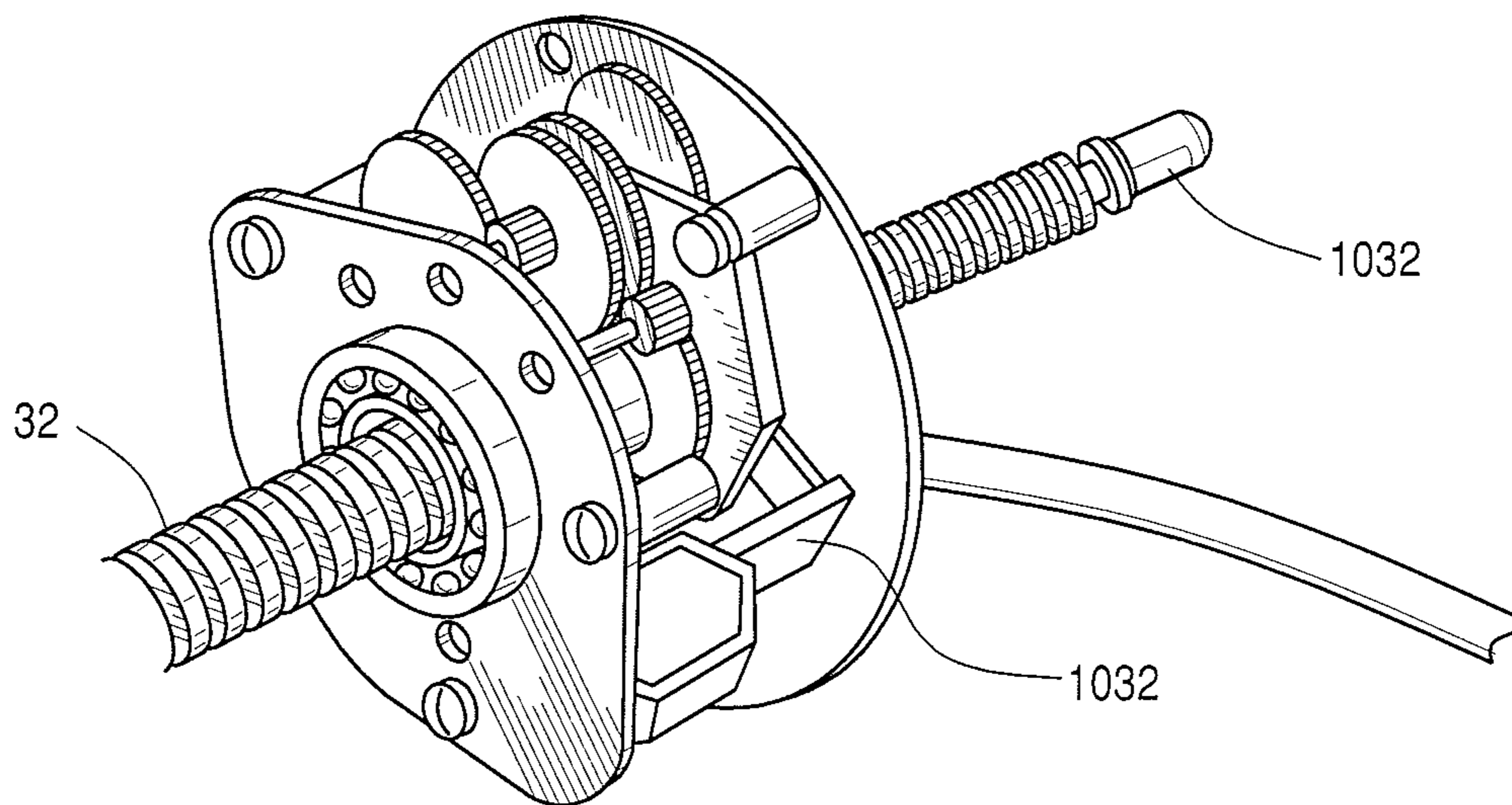

FIG. 112

IMPLANTABLE RESTRICTION SYSTEM WITH RELEASE MECHANISM

BACKGROUND OF THE INVENTION

1. Field of the Invention

This invention relates to laparoscopic implanted restriction system designed to be implanted in the body of a patient around a biological organ having a pouch or duct to regulate functioning of the organ or duct. More specifically, the present invention is directed to an implantable telemetrically powered and controlled ring suitable for use as a gastric band to treat obesity or as an artificial sphincter.

2. Description of the Related Art

Obesity refers to a body weight that exceeds the body's skeletal and physical standards. One well recognized parameter used to measure obesity is Body Mass Index (BMI), because it takes into account patient height and not just weight. BMI is calculated by dividing weight by height squared and is expressed in kg/m².

Obesity is well recognized as a serious health problem, and is associated with numerous health complications, ranging from non-fatal conditions to life-threatening chronic diseases. Surgical intervention generally is the treatment of choice for patients afflicted with morbid obesity. Such intervention not only mitigates the myriad of health problems arising from being overweight, but may also reduce the risk of early death of the patient. Left untreated, morbid obesity may reduce a patient's life expectancy by ten to fifteen years.

Morbidly obese patients as a group are poorly adapted to attain sustainable long-term weight loss using non-surgical approaches, such as strict diets combined with exercise and behavioral modification, even though such methods are acknowledged to be the safest. For this reason, there is a continuing need for direct intervention to provide effective, long-term treatments for morbid obesity. Three main surgical procedures are currently in use: Rouxen-Y Gastric Bypass ("RYGB"), Vertical Banded Gastroplasty ("VBG") and Adjustable Gastric Banding ("AGB").

In RYGB a small stomach pouch is created and a Y-shaped section of the small intestine is attached to the pouch so that food bypasses the lower stomach, the duodenum and the first portion of the jejunum. The RYGB procedure is both restrictive, in that the small pouch limits food intake and malabsorptive, in that the bypass reduces the amount of calories and nutrients the body absorbs.

VBG employs a non-adjustable synthetic band and staples to create a small stomach pouch. AGB employs a constricting synthetic ring defining a gastric band that is placed around the upper end of the stomach to create an artificial stoma within the stomach. The band is filled with saline solution and is connected to a small reservoir/access-port located under the skin of the abdomen. The AGB band may be inflated, thereby reducing the size of the stoma, or deflated, thus enlarging the stoma, by puncturing the access-port with a needle and adding or removing saline solution. Both VBG and AGB are purely restrictive procedures, and have no malabsorptive effect.

It is sometimes necessary to re-operate, either to relieve the patient or to adjust or change the previously implanted band. In such cases, the previously implanted band must be cut and either removed or replaced. These operations are difficult to carry out, difficult for the patient to tolerate and costly.

Several attempts to overcome the drawbacks associated with hydraulically actuated gastric bands, are found in the prior art. For example U.S. Pat. No. 6,547,801 to Dargent et al. describes a surgically implanted gastroplasty system hav-

ing a flexible tactile element that engages a motor-driven notched pulling member. The motor is powered and controlled by an inductive circuit, so that the diameter of the ring may only be changed by operation of an external remote control.

All of the foregoing surgical techniques involve major surgery and may give rise to severe complications. Recent developments have focused on the use of laparoscopic implantation of the gastric ring to minimize patient discomfort and recuperation time.

In view of the foregoing, it would be desirable to provide apparatuses and methods for regulating functioning of a body organ or duct that provides high precision in controlling the degree of constriction imposed upon the organ or duct, without the drawbacks associated with prior control mechanisms.

SUMMARY OF THE INVENTION

It is, therefore, an object of the present invention to provide an apparatus for regulating the functioning of a patient's organ or duct. The apparatus includes an elongated member having a first end and a second end. A fastener is disposed on the first end of the elongated member. The fastener is configured to engage the second end of the elongated member so that the elongated member forms a loop around the organ or duct. A tension element is disposed for movement within the elongated member. A drive element is associated with and engaging the tension element for causing the tension element to control the tension applied by the elongated member against a patient's body organ or duct. A release mechanism is provided for the tension element.

It is also an object of the present invention to provide an apparatus wherein the tension element includes a free end and a fixed end. The fixed end is secured to the drive element via a release mechanism allowing selective release of the fixed end of the tension element from the drive element for release of tension being applied by the elongated member. The release mechanism includes a jaw mechanism that selectively engages the fixed end of the tension element.

It is another object of the present invention to provide an apparatus wherein the jaw mechanism includes a fixed jaw member and a movable jaw member, and a jaw drive element is positioned between the fixed jaw member and the movable jaw member.

It is a further object of the present invention to provide an apparatus wherein the jaw drive element is a balloon which may be selectively expanded for engagement with the fixed jaw member and the movable jaw member in a manner selectively moving the movably jaw member to its release orientation relative to the fixed jaw member.

It is also an object of the present invention to provide an apparatus wherein the jaw drive element is a shape memory alloy spring positioned between the fixed jaw member and the movable jaw members.

It is another object of the present invention to provide an apparatus wherein the shape memory alloy spring is linked to a source of electricity, and upon application of a voltage and/or current across the shape memory alloy spring, the shape memory alloy spring will change shape and thereby force the fixed jaw member and movable jaw members apart in a manner moving the jaw mechanism to its release orientation.

It is a further object of the present invention to provide an apparatus wherein the jaw drive element is a balloon which may be selectively expanded for engagement with the fixed jaw member and the movable jaw member in a manner selec-

tively moving the movable jaw member to its release orientation relative to the fixed jaw member.

It is also an object of the present invention to provide an apparatus wherein the jaw drive element is a balloon which may be selectively expanded for engagement with the fixed jaw member and the movable jaw member in a manner selectively moving the first movable jaw member and the second movably jaw member to their release orientation.

It is another object of the present invention to provide an apparatus wherein the release mechanism is associated with a fluid filling mechanism applying fluid to a bladder formed in the elongated member upon actuation of the release mechanism.

It is a further object of the present invention to provide an apparatus wherein the release mechanism is a fracture mechanism securing the fixed end of the tension element in position.

It is also an object of the present invention to provide an apparatus wherein the fixed end of the tension element is secured to an elongated coupling element extending within a shape memory alloy tube, and wherein upon heating or cooling of the shape memory alloy tube, the tube will change shape in a manner fracturing the elongated coupling element and permitting release of the fixed end of the tension element.

It is another object of the present invention to provide an apparatus wherein a heating coil is positioned about the shape memory alloy tube for selective heating of the shape member alloy tube.

It is a further object of the present invention to provide an apparatus wherein a cooling coil is positioned about the shape memory alloy tube for selective cooling of the shape member alloy tube.

It is also an object of the present invention to provide an apparatus wherein the release mechanism is associated with a fluid source in conjunction with a fluid filling mechanism applying fluid to a bladder formed in the elongated member upon actuation of the release mechanism.

It is another object of the present invention to provide an apparatus wherein the release mechanism is associated with a fluid source that when actuated releases fluid from a bladder formed in the elongated member upon actuation of the release mechanism.

Other objects and advantages of the present invention will become apparent from the following detailed description when viewed in conjunction with the accompanying drawings, which set forth certain embodiments of the invention.

BRIEF DESCRIPTION OF THE DRAWINGS

FIG. 1 is a perspective view of a banding system in accordance with the present invention.

FIGS. 2A and 2B are, respectively, a schematic diagram, partly in cross-section, of the gastric band of FIG. 1 and a sectional view taken along line 2B-2B of FIG. 2A.

FIGS. 3 to 14 show various embodiments enhancing the interior surface of the ring for contact with tissue.

FIGS. 15A and 15B are perspective views illustrating the degree of constriction attainable by the ring of the present invention between the fully open and fully closed positions.

FIGS. 16A and 16B are cross-sectional views of the ring of the present invention along the lines 16A-16A and 16B-16B of FIGS. 15A and 15B, respectively.

FIG. 17 is a partial perspective view of a screw thread portion of the tension element of the present invention.

FIG. 18 is a perspective view of an entire tension element suitable for use in the ring of the present invention.

FIG. 19 is a perspective view of the tension element of FIG. 6 coupled to the rigid dorsal peripheral portion and motor housing of the ring.

FIG. 20 is a perspective view of the ring of FIG. 1 straightened and inserted within a standard 18 mm trocar.

FIG. 21 is a cross-sectional view of an elastomeric housing of the gastric band depicting the path of the antenna wire and cavity that accepts the tension element.

FIG. 22 is a perspective view of the drive element housing, tension element and drive element of the present invention.

FIG. 23 is a perspective view of the tension element engaged with the drive element.

FIG. 24 is a cross-sectional view of a tension element in accordance with an alternate embodiment.

FIG. 25 is a cross-sectional view depicting the construction of the drive element of FIG. 23.

FIG. 26 is a cross-sectional view depicting the construction of the reference position switch.

FIGS. 27 to 38 show various embodiments of drive assemblies, which may be used in accordance with the present invention.

FIGS. 39 to 55 show various embodiments for releasing the fixed end of the tension element from its position at the second end of the ring.

FIGS. 56A-C show another embodiment of implementing a balloon based back-up system in conjunction with the mechanical tension element.

FIGS. 57A, 57B and 58A, 58B show a couple embodiments of releasing fluid from the secondary cavity of the ring.

FIGS. 59 to 71 show various embodiments for releasing the tension element.

FIG. 72 is a schematic showing an alternate embodiment with a titanium case encasing electronic components of the invention.

FIGS. 73 to 76 show additional embodiments for releasing the tension element.

FIGS. 77 to 94 show various embodiments for releasing the free end of the tension element from engagement with the drive element in accordance with the present invention.

FIGS. 95 and 96 show embodiments for accessing the electronic controls of the antenna/controller pod for controlling operation of the ring in accordance with the present invention.

FIGS. 97A and 97B are perspective views illustrating the clip used to close the ring into a loop.

FIGS. 98 and 99 show a release mechanism for a clip of the ring in accordance with an alternate embodiment of the present invention.

FIG. 100 is a perspective view of the antenna/controller pod of the present invention.

FIG. 101 is a cut-away view of the interior of the implantable antenna/controller pod of FIG. 100.

FIG. 102 is a cross-sectional view of the antenna cable of FIG. 100.

FIG. 103 is a detailed view of the signal strength indicator portion of the remote control of FIG. 1.

FIG. 104 is a schematic diagram illustrating placement of the implantable portion of the present invention within a patient.

FIG. 105 is a schematic view of the telemetric power and control circuitry of the present invention.

FIGS. 106 to 112 show various embodiments for monitoring the tension applied by the ring.

DESCRIPTION OF THE PREFERRED EMBODIMENTS

The detailed embodiments of the present invention are disclosed herein. It should be understood, however, that the

disclosed embodiments are merely exemplary of the invention, which may be embodied in various forms. Therefore, the details disclosed herein are not to be interpreted as limiting, but merely as a basis for teaching one skilled in the art how to make and/or use the invention.

Referring now to FIG. 1, the banding or implantable restriction system 1 of the present invention is described. The banding system 1 includes an external control 10 and implantable gastric band 21. In the following description reference will be made, by way of illustration, to a gastric band 21 in the form of a ring 22 designed to be implanted around the stomach to selectively adjust the diameter of the opening of the stoma, and thereby control food intake. Such regulation has the effect of creating a feeling of satiety in the patient after relatively little food is consumed, and provides an effective treatment for morbid obesity.

It is to be understood, however, that the present invention is in no way limited to gastroplasty, but on the contrary, advantageously may be applied to regulate the functioning of other body organs or ducts, such as in the treatment of gastroesophageal reflux disease, urinary or fecal incontinence, colostomy, ileostomy or to regulate blood flow in connection with isolated organ perfusion for treatment of cancer. When applied in the treatment of urinary continence, the implantable portion of the present banding system 1, in particular, the elongated member in the form of a ring 22 will be implanted around the bladder or urinary tract, while in the case of fecal incontinence, the ring 22 may be implanted around a portion of the gastro-intestinal tracts, such as anal structures of the intestine. With this in mind, the present banding system 1 is MRI compatible and all elements thereof are non-ferromagnetic.

As discussed above, the present invention relates to an implantable restriction system. A preferred embodiment of the implantable restriction system is disclosed herein with reference to a gastric band used in restricting the effective size of the stomach for application in bariatric procedures. As such, the implantable restriction system of the present invention is referred to as including a gastric band or ring throughout the present disclosure, although those skilled in the art will appreciate the concepts underlying the present invention may be applied in a variety of implantable restriction devices as briefly discussed above.

System Overview

With respect to FIG. 1, the self-contained external control 10 comprises a housing 11 having a control panel 12 and a display screen 13. The external control 10 includes a digital signal processor and may be battery-powered or powered using an external power supply, e.g., connected to an electric wall outlet. An external antenna 14 is coupled to the external control 10 via a cable 15. As described more fully with respect to FIG. 105, the external control 10 includes a controller (such as a microprocessor) that controls the emission of radiofrequency signals to the gastric band 21 to both control and power operation of the gastric band 21.

The external control 10 accepts a patient microchip card 16, which corresponds to the specific gastric band 21 implanted in the patient, and stores data, such as the implant identification number, adjustment parameters (e.g., upper and lower limits of an adjustment range, etc.) and information regarding the last adjustment position of the ring 22. The external control 10 as shown in FIG. 1 includes a signal strength indicator 17, as described in more detail below with respect to FIG. 103, an ON/OFF button 18, an OPEN button 19a, a CLOSE button 19b, a COUPLING button 19c and a menu options panel 20.

During use of the present banding system 1, the physician need only turn on external control 10 using the ON/OFF button 18, position the external antenna 14 over the patient's chest above antenna/controller pod 23, check the coupling by depressing the COUPLING button 19c, and when the coupling is sufficient, adjust the degree of constriction using the OPEN button 19a or the CLOSE button 19b to control the effective circumference of the ring 22 in a manner discussed below in greater detail. The diameter of the gastric band 21 is continually displayed on the display screen 13 with a precision of about 0.1 mm for the entire range of diameters of the ring 22, e.g., from 19 mm fully closed to 29 mm fully opened.

Still referring to FIG. 1 and as briefly mentioned above, the gastric band 21 of the present invention includes a ring 22 coupled to an implantable antenna/controller pod 23 via an antenna cable 24. The antenna/controller pod 23 includes a removable tag 25 that may be used to laparoscopically position the ring 22. The ring 22 includes a first end 26 having a clip 27 that slides over and positively engages a second end 28 of the ring 22.

As described in detail below, the ring 22 is configured to be straightened to pass through the lumen of a commercially available 18 mm trocar for delivery to a patient's abdomen (see FIG. 20). The tag 25, antenna/controller pod 23 and antenna cable 24 are passed through a clip 27 to form the gastric band 21 into a substantially circular ring 22 around an upper portion of the patient's stomach, thereby reducing the diameter of the opening of the stomach. In its undeformed shape, the ring 22 assumes a circular arc configuration that facilitates positioning of the ring 22 around the stomach and also in self-guiding the clipping procedure.

The ring 22 of the present invention comprises a flexible tubular member having a smooth, flexible and elastic membrane, thus ensuring atraumatic contact with the patient's stomach tissue that is easily tolerated. When engaged with a dorsal element 38, the membrane 39 is stretched by an appropriate factor (i.e., 20%-40%), so that when the ring 22 is in its fully closed position, little or no wrinkling appears on the membrane surface. The ring 22 has approximately the shape of a torus of revolution of substantially cylindrical cross-section. Alternatively, the ring 22 may have other suitable cross-sections, including rectangular. The housing 29 on the second end 28 of the ring 22, the clip 27 on the first end 26 of the ring 22 and the dorsal peripheral portion 30 of the ring 22, preferably are made of a biocompatible material such as silicone. An interior portion 31 of the ring 22 may be constructed in a variety of manners as discussed below in greater detail to permit engagement with the tissue without bunching or rippling, and, as discussed below in greater detail, may be covered in various manners to enhance the ring/tissue interface and protect the ring 22.

Implantable Ring

Referring now to FIGS. 2A and 2B, the internal structure of the ring 22 is described. In particular, and as depicted in FIG. 2A, the ring 22 includes a flexible tension element 32 having a fixed end 33 statically mounted to the first end 26 of the ring 22 and a free end 34 that is engaged with a motor-driven drive element 35 and extends into a cavity in the housing 29. The tension element 32 is slidingly disposed within a substantially cylindrical tube of a compressible material 36, e.g., ePTFE, as illustrated in FIG. 2B, so that when the tension element 32 is pulled through the drive element 35, the compressible material 36 is compressed and the diameter of opening 37 is reduced. The compressible material 36 is preferably surrounded on its dorsal face by a dorsal element 38. The dorsal element 38 is flexible, but sturdier than the elastomeric material of the compressible material. The dorsal element is pref-

erably composed of silicone. Both the compressible material **36** and the silicone dorsal element **38** preferably are enclosed within a membrane **39** of elastomeric biocompatible material, as shown in FIG. 2B, to prevent tissue in-growth between the ePTFE compressible material **36** and the silicone dorsal element **38**. The membrane **39** may be affixed to the dorsal element **38** using a biocompatible glue to prevent leakage in case of accidental puncture on the dorsal surface.

With reference to FIGS. 3 to 14, various embodiments have been developed for improving the interaction between the inner surface **112** of the ring **22** and the tissue it engages as the band **21** is constricted about the stomach of a patient. In accordance with a first embodiment as shown with reference to FIG. 3, a fluid bladder **114** is added to the inner surface **112** along the internal circumference of the ring **22** such that the fluid bladder **114** interfaces with the tissue. In addition, to improving the tissue band interface, the addition of a fluid bladder **114** along the inner surface **112** of the ring **22** allows for ready adjustments to the restrictive level of the ring **22**.

In accordance with such an embodiment, and as briefly discussed above, the fluid bladder **114** is formed along the inner surface **112** of the ring **22** for direct engagement with the tissue when the ring **22** is applied to the stomach and constricted thereabout. The fluid bladder **114** is preferably made of silicone (or other biocompatible material) and is constructed as an elongated cylindrical member **116** with a high degree of flexibility allowing it to conform to the surface of the tissue to which it is applied without adversely affecting the tissue when applied thereto for long periods of time. The cylindrical member **116** extends about substantially the entire length of the inner circumference of the ring **22**. As such, the fluid bladder **114** includes a first end **118** adjacent the first end **26** of the ring **22** and a second end **120** adjacent the second end **28** of the ring **22**.

The cylindrical member **116** includes a central lumen **121** shaped and dimensioned to receive a filling fluid as discussed below. The cylindrical member **116**, and ultimately the central lumen **121**, includes the closed first end **118** and the open second end **120**. The second end **120** is provided with a port **122** in fluid communication with a filling tube **124** that extends from the fluid bladder **114** to a remote fluid source **126** allowing for the controlled application of the fluid to the fluid bladder **114** for filling thereof as desired by the medical practitioner deploying and installing the present ring **22**. In accordance with such an embodiment, it is contemplated the remote source of fluid **126** could be integrated with the antenna/controller pod **23** as discussed below in greater detail.

The filling tube **124** is provided with a first end **128** which is secured to the port **122** of the fluid bladder **114** and a second end **130** positioned remote from the first end **128**. The second end **130** is fixedly or selectively secured to a source of fluid **126** for filling the fluid bladder **114** as one may desire in accordance with the principles of the present invention. In accordance with a preferred embodiment, the fluid source **126** is a miniature fill port which is subcutaneously implanted (for example, in conjunction with the antenna/controller pod **23**) for access and addition of fluid as required by the needs of the patient being treated. The fill port **126** includes a flexible access septum **129** through which the medical practitioner may access the internal cavity **131** of the fill port **126** for increasing or decreasing the volume of fluid applied to the fluid bladder **114** positioned along the inner surface **112** of the ring **22** and in direct contact with the tissue of the stomach.

It is further contemplated that to achieve a softer tissue interface without secondary adjustability, the fluid bladder may be prefilled prior to implantation. Where such an imple-

mentation is employed, a fluid port would not be required. The fluid could be added directly through a catheter attached to the fluid bladder. Once added, the fluid would be trapped by plugging the catheter (for example, tying in a knot, adding a fluid plug, lues activated valve, etc.).

In the event of a mechanical or electrical adjustment feature failure the fluid bladder would allow at least minor adjustments to the band. The fluid bladder can be used as a safety feature in case the mechanical adjustment is not functioning properly, since fluid could easily be removed from the bladder un-tightening the gastric band and relieving the pressure applied to the stomach.

It is contemplated the fluid bladder could be prefilled with a substance or solution prior to installation. Where the fluid bladder is prefilled, the fluid within the fluid bladder is hyperosmolar relative to the implanted physiological environment. For example, the filling fluid may be a salt solution or ionic polymer solution, sodium alginate, sodium hyaluronate, etc. The fluid may also be hypo-osmolar relative to the implanted physiological environment, such as, a non-ionic polymer solution poly(ethylene glycol). The fluid may also be a non-Newtonian fluid, such as, a polymer solution selected from the group consisting of a poly(vinylpyrrolidone), carboxymethylcellulose, poly(ethylene glycol), poly(aciylamid), sodium hyaluronate, hyaluronic acid, and alginates. The fluid may further be a non-aqueous fluid or gel, such as, a silicone oil or fluorosilicone oil.

In accordance with an alternate embodiment, the ring **22** is shaped and dimensioned to provide for more compliant material and/or construction by altering the cross sectional geometry of the ring **22** to reduce the spring constant of the compressible material **36** between the tension element **32** and the tissue. In addition, improved compliance and construction are achieved by altering the construction of the gastric band **21** such that a secondary, softer material is introduced into the space between the tension element **32** and the tissue, giving the gastric band **21** a reduced spring constant. Improved compliance and construction is further achieved by combining a reduced spring constant with a viscoelastic filler material to give viscoelastic (or rate dependent) deformation characteristics.

In accordance with this embodiment, and as show with reference to embodiments shown in FIGS. 4 to 8, variations in the spring constant of the gastric band **21** between the tension element **32** and the tissue is achieved through the formation of longitudinally extending space(s) **132** within the compressible material **36**. In accordance with a preferred embodiment, the space(s) **132** maintains a constant shape along the length of the compressible material **36**, although it is contemplated the shapes of the space(s) **132** may be varied along the length of the compressible material **36** and the ring **22**. In practice of the present embodiment, the spring constants may be derived or inferred from tissue interface pressures in the range of -100 mmHg to 300 mmHg gauge pressure wherein the basic relationship is determined by the formula $p=F/A$. However, it is also contemplated pressures outside this range may also be used.

The space(s) **132** may be filled with another material such as silicone rubber, a lower durometer polymer or closed-cell foam to give a reduced spring constant. The space(s) **132** within the cross section may also include viscous or viscoelastic filler materials. That is, they demonstrate rate dependent response to dynamic force conditions such as the passage of food through the esophagus. Potential viscous/viscoelastic filler materials include, but are not limited to, saline liquid or gel silicone, biogels, close cell foams, or pack granules or spears of one or more materials.

In addition to improving the spring constant, the incorporation of open space(s) **132** in the compressible material **36** as disclosed herein maximizes the interface between the ring **22** and the tissue thereby spreading the forces or interface pressures applied to the tissue in accordance with the present invention.

As discussed above, the space(s) **132** may take a variety of forms. For example, and with reference to FIG. 4, the space **132** takes the form of a substantially C-shaped lumen. In accordance with an alternate embodiment as shown with reference to FIG. 5, the space **132** takes the form of truncated triangle wherein the top section (that is, the narrow portion adjacent the tension element **32**) of the triangle is curved and the bottom section (that is, the wide portion removed from the tension element **32**) of the triangle includes a slightly concave base. In accordance with yet a further embodiment, and with reference to FIG. 6, first and second arcuate spaces **132** are provided on opposite sides of the ring **22**. Once again, and with reference to FIG. 7, four elongated spaces **132** are provided. The elongated spaces **132** are oriented such that when viewed across the cross section of the ring **22**, the longitudinal axis thereof extends transversely against the longitudinal axis passing through the center of the ring **22**. In accordance with yet a further embodiment, and with reference to FIG. 8, the spaces **132** are formed so as to extend circumferentially about the compressible material **36** of the ring **22** and take the form of arcuate members whose concave surfaces **134** faces away from the center of the ring **22** and whose convex surfaces **136** face away from the center of the ring **22**.

In accordance with yet another embodiment of the present invention, and with reference to FIG. 9, the ring **22**, and in particular, the compressible material **36**, may be provided with a fluid chamber **138** extending along the inner circumferential portion of the compressible material **36**. In contrast to the embodiment disclosed above with reference to FIG. 3, the fluid lumen or chamber **138** forms part of the compressible material and is preferably integrally formed with the compressible material **36**. As such, the compressible material **36** may be thought of as including a fluid lumen **138** along its inner surface, the fluid lumen **138** being shaped and dimensioned for maintaining a desired fluid therein so as to improve the stress profile being applied to the tissue.

In accordance with a preferred embodiment of the present invention, the fluid chamber **138** includes a cross-sectional profile, when viewed along a plane transverse to the circumferential axis running along the center of the ring **22**, that remains constant along the length of the ring **22**. The profile is elliptical defining an arcuate inner wall **140** and an arcuate outer wall **142** with the concave surfaces thereof facing each other.

In addition to improving the tissue to ring interface by providing greater compliance along this area, the fluid chamber **138** may also allow for expansion of the gastric band **21** in the event the mechanical adjustment system fails. In particular, the fluid lumen **138** is maintained in fluid communication with a remote fluid pressure source as discussed above with reference to FIG. 3. As such, and if the mechanical or electrical adjustment feature fails, fluid may be pumped into the fluid lumen **138** creating additional pressure that is transferred to the stomach about which the ring **22** is positioned. Alternatively, fluid may be removed from the fluid lumen **138** thereby relieving pressure applied to the stomach about which the ring **22** is positioned. In accordance with a preferred embodiment, it is contemplated the fluid source may be housed in and controlled by the antenna/controller pod **23** of

the ring **22**. It is further contemplated, the fluid source may also be manually adjusted by a separate connection to a fluid port.

In accordance with still a further embodiment, the cross-sectional geometry of the gastric band **21** may be varied to cover other alternatives. As shown with reference to FIG. 10, the geometry is altered such that the tension element **32** is positioned off center of the compressible material **36**, that is, the cross sectional area of the ring **22** itself. By doing this, the tension element **32** takes advantage of rotational torque resulting from the off center positioning and produces mechanical advantages during the constriction of the ring **22**.

With reference to the embodiments shown with reference to FIGS. 12 and 13, a softer tissue ring interface is achieved by positioning a flexible strip **146** along the inner surface **112** of the ring **22**, and between the compressible material **36** and the membrane **39**. This strip **146** is designed to spread the forces of the tension element **32** along the entire circumference of the ring **22** and is preferably made from a polymer. With reference to FIG. 11, the strip **146** is placed along the inner surface **112** of the ring **22**, and not between the compressible material **36** and the membrane **39**. In accordance with a preferred embodiment, the strip **146** includes an inner surface **148** and an outer surface **150**. The inner surface **148** is substantially smooth and flat and is adapted to directly face the tissue upon constriction of the ring **22**, with the strip **146** positioned between the compressible material **36** and the membrane **39**. The outer surface **150** includes substantially flat portions **152** and a central protrusion **154** which is shaped and dimensioned to directly engage the tension element **32** upon constriction thereof. As such, and when the tension element **32** is tightened, the tension element **32** applies pressure directly to the central protrusion **154** of the flexible strip **146**. This pressure is transferred along the entire length of the flexible strip **146** such that pressure is evenly distributed along the inner surface **148** of the strip **146**. In accordance with yet another embodiment, and with reference to FIG. 14, the inner surface **148** of the strip **146** may take the form of a resilient tubular member **147** with additional compliance. By utilizing such a design, the interior volume **145** defined by the strip **146** may be filled with viscoelastic materials enhancing the compliance of the strip **146** and the overall tissue ring interface.

In accordance with one aspect of the present invention, and with reference to FIGS. 15A, 15B, 16A and 16B, the ring **22** further comprises a layer **40** of a relatively rigid material disposed on the dorsal periphery of the ring **22**. The layer **40**, which may comprise a plastic or metal alloy, prevents the exterior diameter **D** of the ring **22** from changing during adjustment of the tension element **32** to reduce the internal diameter (or opening **37**) of the ring **22**. The layer **40**, by its structural rigidity, imposes a circular arc shape for the entirety of the ring **22**. Advantageously, the layer **40** allows the tension element **32** to be adjusted following encapsulation of the ring **22** by fibrous tissue after implantation, since adjustment of the internal diameter of the ring **22** does not change the external diameter **D** of the ring **22**.

The foregoing feature is illustrated in FIGS. 15A and 15B where the ring **22** is shown in its fully opened and fully closed positions, respectively. As discussed above, the layer **40** forms a rigid skeleton that permits the internal diameter of the ring **22** to change while maintaining the external diameter **D** constant. Radial movement of the tension element **32** is transmitted to the membrane **39** by the compressible material **36**. ePTFE is particularly well-suited for use as the compressible material **36** because it can undergo a 3:1 reduction in length without experiencing a significant increase in cross-section.

11

Accordingly, and as depicted in FIGS. 16A and 16B, increase or reduction of the effective length of the tension element 32 results in reversible radial displacement at the internal periphery of the ring 22 opposite the dorsal periphery. This in turn translates into a variation of internal diameter of the ring 22 from a fully open diameter to a fully closed diameter by expanding or controlling the ring 22 to control the tension applied by the ring 22 against a patient's body organ or duct. Preferably, the fully open internal diameter is about 35 mm, and the fully closed internal diameter is about 15 mm. More preferably, the fully open internal diameter is about 29 mm, and the fully closed internal diameter is about 19 mm.

Referring now to FIG. 17, the tension element 32 in accordance with a first embodiment is described. This tension element is disclosed in detail in U.S. Patent Application Publication No. 2005/0143766, which is incorporated herein by reference. Briefly, the tension element 32 has sufficient flexibility to permit it to be formed into the substantially circular shape of the ring 22, while also being able to transmit the force necessary to adjust the ring diameter. The tension element 32 therefore comprises a flexible core 41, preferably a metal alloy wire of circular cross section, on which is fixed, and wound coaxially, at least one un-joined coil spring which defines the screw thread pitch.

As shown in FIG. 17, the tension element 32 preferably comprises two un-joined coil springs that form a screw thread: a first spring 42, wound helicoidally along the flexible core 41, and a second spring 43 of greater exterior diameter. The second spring 43 preferably comprises coils 44 of rectangular transverse section, so as to delineate a flat external generatrix. The first spring 42 is interposed between coils 44 of the second spring 43 to define and maintain a substantially constant square screw thread pitch, even when the tension element 32 is subjected to bending.

As a consequence of the foregoing arrangement, the ability of the tension element 32 to maintain a substantially constant thread pitch, when subjected to bending, confers great precision on adjustments of the ring 22. This is especially so when it is realized that as the tension element 32 is drawn through the drive element 35, an ever-increasing curvature is imposed on the remaining portion of the tension element 32. However, because the foregoing arrangement of un-joined coils maintains a substantially constant screw thread pitch, the energy needed to drive the drive element 35 remains low and the efficiency of energy transmission resulting from the use of a square screw thread pitch remains high. In addition, the use of a square screw thread pitch guarantees a stable adjustment position even when the drive element is unpowered.

Referring now to FIG. 18, the tension element 32 is described. The free end 34 includes a crimped cap 45, the second spring 43 has coils with a square transverse section, and the first spring 42 (not visible in FIG. 18, but shown in FIG. 17) is intertwined between the coils of the second spring 43. The flexible core 41 extends through the first and second springs 42, 43, and terminates close to the crimped cap 45. In accordance with one aspect of the present invention, the tension element 32 further comprises a third spring 46 that is coupled to the flexible core 41, and the first and second springs 42, 43 at junction 47. The third spring 46 includes a loop 48 at the end opposite to junction 47, which permits the tension element 32 to be mounted to the first end 26 of the ring 22.

With respect to FIG. 19, the tension element 32 is shown disposed within a skeleton 50 of the ring 22. The skeleton 50 includes a layer 51 that forms the dorsal periphery (corresponding to the layer 40 of FIGS. 2A, 2B, 16A and 16B), an

12

anchor 52 that accepts the loop 48 of the tension element 32, and a drive element housing 53. The skeleton 50 is preferably constructed from a high strength moldable plastic. As further depicted in FIG. 19, the skeleton 50 extends along a greater arc length than the tension element 32. In accordance with another aspect of the present invention, the third spring 46 permits the gastric band 21 to be straightened for insertion through a standard 18 mm trocar, despite the differential elongation of the skeleton 50 and the tension element 32. This feature is illustrated in FIG. 20, which depicts the ring 22 inserted through 18 mm trocar 55 so that the ring 22 is substantially straight.

Referring now to FIG. 21, the housing 29 of the free end of the ring 22 is described. The housing 29 comprises an elastomeric material, such as silicone, having a recessed portion 56, a tension element cavity 57 and a cable lumen 58. The recessed portion 56 is configured to accept the drive element housing 53 of the skeleton 50, so that as the tension element 32 is drawn through the drive element 35 it extends into the tension element cavity 57. A cable lumen 58 extends through the housing 29 so that the antenna cable 24 may be coupled to the drive element 35. The housing 29 preferably may be grasped in area G using atraumatic laparoscopic graspers during manipulation of the gastric band 21.

In FIG. 22, the drive element housing 53 of the skeleton 50 is shown with the drive element 35 and the tension element 32 disposed therethrough. The antenna cable 24 is coupled to a motor (not shown) disposed within the drive element housing 53. The tension element 32 is in the fully opened (largest diameter) position, so that the crimped cap 45 contacts the printed circuit board 59 of the reference position switch, described below with respect to FIG. 26.

Because the tension element 32 must be drawn through the drive element 35 to cause tightening thereof, the tension element 32 described above necessarily requires that the tail end 34, that is, the end nearest crimped cap 45, of the tension element 32 extends beyond the drive element 35 with the extending portion increasing as the ring 22 is tightened, making potential interference with the viscera possible. In addition, the tension element 32 may cause localized stress to the inside surface, for example, the compressible material 36, of the gastric band 21 as well as potentially to the viscera.

In accordance with an alternate embodiment and with reference to FIG. 24, the diameter of the ring 22 is adjusted without the need for a tension element including a tail end which is extended and retracted as the need for adjustments in the diameter of the ring 22 are desired. The tension element 32 in accordance with this embodiment is composed of an inner first strap member 440, an outer second strap member 442 and a camming strap member 444 moveably positioned therebetween. The first strap member 440 includes an inner surface 446 and an outer surface 448, the second strap member 442 includes an inner surface 452 and an outer surface 454, and the camming strap member 444 includes an inner surface 456 and an outer surface 458. The inner surface 446 of the first strap member 440 is substantially smooth and is shaped and dimensioned for facing the tissue which the ring 22 engages. The outer surface 448 of the first strap member 440 includes a plurality of recessed camming surfaces 460 shaped and dimensioned for interacting with protruding camming surfaces extending from the inner surface 456 of the camming strap member 444. Similarly, the outer surface 454 of the second strap member 442 is substantially smooth and is shaped and dimensioned for facing the tissue which the ring 22 engages. The inner surface 452 of the second strap member 442 includes a plurality of recessed camming surfaces 464

shaped and dimensioned for interacting with protruding camming surfaces **466** extending from the outer surface **454** of the camming strap member **444**.

As discussed above, the camming strap member **444** is shaped and dimensioned for positioning between the first strap member **440** and the second strap member **442** in manner such that the camming strap member **444** is in sliding contact with the first and second strap members **440**, **442** but is free to move relative thereto. As such, when the camming strap member **444** moves circumferentially relative to the first and second strap members **440**, **442**, the protruding camming surfaces **462**, **466** of the camming strap member **444** interact with the recessed camming surfaces **460**, **464** of the respective first and second strap members **440**, **442**. As a result of this interaction, the first strap member **440** is caused to move inwardly or outwardly selectively decreasing or increasing the effective diameter of the ring **22**.

Controlled movement of the camming strap member **444** is achieved by a drive element **470** secured at the first end **472** of the camming strap member **444**. In accordance with a preferred embodiment, the drive element **470** is a conventional drive mechanism, for example, screw drive, friction belt drive, servomotor, etc.

It is further contemplated the recessed camming surfaces **460**, **464** and the protruding camming surface **462**, **466** may be adjusted in height and location along the circumference of the tension element **32** so as to adjust the ability of the tension element **32** to control adjustments in the diameter of the ring **22**. That is, the total adjustment range of the tension element **32** will depend on the configuration of the recessed and protruding camming surfaces **460**, **462**, **464**, **466**, specifically, the number of camming surfaces and the height of the camming surface. In the simplest case the adjustment diameters could be described as

$$\begin{aligned} \theta_i &= \text{original diameter} \\ h &= \text{height of wedge} \\ \theta_f &= \text{final diameter} \\ \theta_f &= \theta_i + 2(h) \end{aligned}$$

This tension element **32** construction offers a variety of advantages, including: the cost of the flexible spring assembly disclosed with reference to other embodiments can be avoided and the total throw of the motor can be reduced therefore reducing the length of the tail section. Multiple camming surface configurations can be adapted to the design to achieve different adjustment ranges while a constant pressure profile on the restricted tissue can be maintained.

Drive Element

With respect to FIGS. **25** and **26**, the drive element **35** used in conjunction with the tension element **32** disclosed with reference to FIGS. **22** and **23**, includes a motor **66** coupled to the antenna cable **24** that drives the nut **60** through the gears **61**. As with the various embodiments presented throughout the present disclosure, the motor may take a variety of forms including, but not limited to a stepper motor and piezo motor. The nut **60** is supported by upper and lower bearings **62** to minimize energy losses due to friction. The nut **60** is self-centering, self-guiding and provides high torque-to-axial force transfer. The drive element **35** is disclosed in greater detail with reference to U.S. Patent Application Publication No. 2005/0143766, entitled "TELEMETRICALLY CONTROLLED BAND FOR REGULATING FUNCTIONING OF A BODY ORGAN OR DUCT, AND METHODS OF MAKING, IMPLANTATION AND USE", which is incorporated herein by reference.

Referring now to FIG. **26**, the reference position switch of the present banding system **1** is described. Because the drive element **35** of the present banding system **1** employs a nut **60**

driven by a stepper motor **66**, there is no need for the system to include a position sensor or encoder to determine the length of the tension element **32** drawn through the drive element **35**. Instead, the diameter of the ring **22** may be directly computed as a function of the screw thread pitch and the number of rotations of the nut **60**. To ensure an accurate calculation of the degree of restriction imposed by the ring **22**, however, it is desirable to provide at least one reference point.

This reference datum is accomplished in the ring **22** of the present invention using a reference position switch that is activated when the ring **22** is moved to its fully open position. The crimped cap **45** on the free end of the tension element **32** serves this function by contacting electrical traces **63** on the printed circuit board **59** (and also limits elongation of the screw thread). The circuit board **59** is disposed just above the bearing **65**, which forms part of the drive element **35** (see also FIG. **22**). When the crimped cap **45** contacts the traces **63**, it closes a switch that signals the implantable controller that the ring **22** is in the fully open position.

In accordance with an alternate embodiment, and with reference to FIG. **27**, a symmetrical drive system **170** is employed. Briefly, and in accordance with a preferred embodiment of the present invention, the drive system **170** employs two flexible members **172**, **174** which, in accordance with a preferred embodiment of the present invention, are flexible screws simultaneously operating upon the tension element **32** using a single motor **176** with a dual actuated drive **178**, **180**. The dual actuated drives **178**, **180** provide directional control for loosening or tightening the flexible members **172**, **174**. In accordance with a preferred embodiment of the present invention, the body of the tension element **32** is constructed in substantially the same manner as that described with reference to the embodiment shown in FIGS. **17**, **18** and **19**. However, and considering the flexible members interact with the dual actuated drives for controlled construction and expansion of the ring **22**, the body of the tension element may be constructed of various materials and may be constructed without departing from the spirit of the present invention. However, and as will be appreciated based upon the following disclosure, flexible first and second screws **172**, **174** are secured to the opposite ends **183**, **194** of the tension element **32** allowing for actuation in accordance with the embodiment disclosed herein.

By drawing the tension element **32** at both ends, and simultaneously applying pressure to the opposite ends, the applied tension is uniformly distributed along the length of the tension element **32**.

More particularly, a flexible first screw **172** is provided at one end of the tension element **32**. The first screw **172** includes a first end **182** and a second end **184**. The first end **182** is secured to a first end **183** of the tension element **32** and the second end **184** is fed into a first actuated drive **178** of the motor **176**. Similarly, the flexible second screw **174** includes a first end **186** and a second end **188**. The first end **186** is secured to a second end **194** of the tension element **32** and the second end **188** is fed into a second actuated drive **180** of the motor **176**. With the first and second ends **183**, **194** of the tension element **32** respectively secured to the first end **182** of the first screw **172** and the first end **186** of the second screw **174**, and the motor **176** connecting the second ends **184**, **188** of the first and second screws **172**, **174**, a complete circular loop is created. The effective circumference of the circular loop is, therefore, readily adjusted by manipulating the extent to which the first and second screws **172**, **174** are drawn into the first and second actuated drives **178**, **180** of the motor **176**.

As briefly discussed above, the motor **176** is provided with first and second actuated drives **178**, **180**. The first and second

actuated drives **178, 180** include respective inputs **195, 196** that are positioned on opposites sides of the motor **176** for receiving the second ends **184, 188** of the respective first and second screws **172, 174**. As such, the second end **184** of the first screw **172** is fed into the input **195** of the first actuated drive **178** where it is engaged by a drive mechanism (for example, a screw drive in accordance with a preferred embodiment of the present invention). The second end **188** of the second screw **174** is fed into the input **196** of the second actuated drive **180** where it is engaged by a drive mechanism (for example, a screw drive in accordance with a preferred embodiment of the present invention).

In accordance with a preferred embodiment, the drive mechanisms of the first actuated drive **178** and the second actuated drive **180** employ nut-like features upon which a threaded surface of the first and second screws **172, 174** ride so as to push or pull the first and second screws **172, 174** through the motor body. When the motor **176** is energized, the first and second screws **172, 174** move in opposite directions and tighten the tension element **32** about a central axis of the ring **22**. Because both screws **172, 174** move at the same time, the tension element **32**, and ultimately, the gastric band **21**, can be adjusted twice as fast as a single direction screw with the same amount of work.

With the first screw **172** engaged by the drive mechanism of the first actuated drive **178** and the second screw **174** engaged by the drive mechanism of the second actuated drive **180**, actuation of the motor **176** is controlled to actuate the first and second actuated drives **178, 180** to either simultaneous draw the first and second screws **172, 174** into the motor **176** or the simultaneous push the first and second screws **172, 174** out of the motor **176** for either decreasing or increasing the effective circumference of the tension element **32**.

By employing the embodiment described above, symmetrical movement allows for a more uniform distribution of force on the tension element **32**. The tension element **32** is also fixedly secured to the ring **22** at an anchor point **175** diametrically opposite the motor **176**. In this way, the first and second screws **172, 174** connected to the tension element **32** pull the membrane **39** of the ring **22** uniformly inward or outward from the anchor point **175** diametrically opposite the motor **176** of the gastric band **21**. It should be noted that is contemplated that the anchor point is not limited to the top of the gastric band but may be located at one side or opposite the motor drive.

In accordance with an alternate embodiment as shown with reference to FIGS. **28** and **29**, the drive system **170** includes a tension element **32** composed of two flexible members (referred to as springs) **202, 204**. The springs **202, 204** are linked together so as to define the tension element **32** used in increasing or decreasing the circumference of the ring. The flexible first member **202** is threaded externally like a bolt (inner spring) and the flexible second member **204** is internally threaded like a nut (outer spring). The inner spring **202** is shaped and dimensioned to seat within the outer spring **204** in a manner coupling the inner and outer springs **202, 204** but allowing rotation of the outer spring **204** relative to the inner spring **202** for controlled adjustment of their relative positions as discussed below in greater detail.

More particularly, the outer spring **204** is attached to a rotational motor **176** with the inner spring **202** threaded into the outer spring **204**. As the motor **176** turns the inner spring **202** is either drawn into or pushed farther out of the outer spring **204** to either reduce or increase the diameter of the stoma defined by the ring **22**. To prevent total restriction of the stomach, the outer spring **204** or inner spring **202** is provided with a hard stop **206** that will prevent further restriction. It

will be appreciated that the inner and outer springs could also be thought of as a flexible screw and flexible nut.

Referring now to FIGS. **30** and **31**, yet another embodiment is disclosed. In accordance with this embodiment, the tension element **32** mounted within the ring **22** is provided with a flexible hollow threaded shaft **208** at its first end **26** and a flexible threaded shaft **210** at its opposite second end **28**. The threaded shaft **210** is movably coupled to a drive motor **176** secured at the free end **212** of the hollow threaded shaft **208** for controlling movement of the first end **283** of the tension element **32** relative to the second end **294** of the tension element **32**.

More particularly, the hollow threaded shaft **208** defining the first end **283** of the tension element **32** includes a free end **212** and a coupled end **214**, while the threaded shaft **210** defining the second end **224** of the tension element **32** includes a free end **216** and a coupled end **218**. The coupled end **214** of the hollow threaded shaft **208** is secured to the coupled end **218** of the threaded shaft **210**.

A drive motor **176** is secured to the free end **212** of the hollow threaded shaft **208**. The drive motor **176** includes an input passageway **220** shaped and dimensioned to guide the threaded shaft **210** therethrough and into the cavity **222** defined by the hollow threaded shaft **208**. As such, and with the threaded shaft **210** engaged with the drive motor **176**, the drive motor **176** is actuated to either draw into or push threaded shaft **210** out of the hollow threaded shaft **208** to either reduce or increase the diameter of the stoma defined by the ring **22**. To prevent excessive inward or outward movement, it is contemplated the threaded shafts may be provided with a hard stop(s) (not shown). Additionally, to facilitate connection to the coupled end of the hollow shaft a tapered lead end feature may be added to the free end of the threaded shaft. Similarly, it is further contemplated the hollow threaded shaft may have a cone like feature to more readily facilitate alignment to the threaded shaft during connection.

In accordance with yet a further embodiment and with reference to FIGS. **32** to **38**, a quick connect coupling **224** for use in conjunction with a screw drive mechanism **226** is employed. The quick connect coupling **224** is a snap-together feature molded into a central segment **228** of the ring **22**.

More particularly, the ring **22** contains the silicone sleeve that interacts with the patient's stomach to create the gastric band **21**, but the ring **22** is split at the central segment **228** to allow for controlled splitting of the ring **22** in a manner allowing for ease of deployment and ease of removal. As with the embodiments discussed above, a tension element **32** extends within the ring **22** and similarly includes a split in the central segment **228**. Accordingly, the ring **22** may be thought of as including a first segment **230** and a second segment **232**. The first segment **230** includes a first end **234** and a second end **236** and the second segment **232** includes a first end **240** and a second end **242**. The tension element **32** is similar composed of a first tension segment **244** and a second tension segment **246**. The first tension segment **244** includes a first end **248** and a second end **250** and the second tension segment **246** includes a first end **252** and second end **254**. The first end **234** of the first segment **230** and the first end **240** of the second segment **232** are linked at the motor **176** that couples the first end **248** of the first tension segment **244** to the first end **252** of the second tension segment **246**. Completing the circle defined by the ring and tension elements **230, 232**, the second ends **236, 250** of the first segment **230** and first tension segment **244** and the second ends **242, 254** of the second segment **232** and second tension segment **246** are linked via the quick connect coupling **224**.

In practice, the gastric band **21**, with the quick connect coupling **224** disconnected allows the second ends **236**, **242** of the first and second segments **230**, **232** of the ring **22** to move freely relative to each other. Thus, the ring **22** can be positioned adjacent the stomach and the quick connect coupling **224** is used by the surgeon to first place and attach the gastric band **21** during surgery. The first end **248** of the first tension segment **244** and the first end **252** the second tension segment **246** each terminate with a drive screw **256**. The drive screws **256** engage the drive motor **176** and are actuated thereby. The motor **176** may then be used to open and close the gastric band **21** about the stomach of the user.

It is contemplated the first and second tension segments **244**, **246** could be made of braided cable, laminate polymers, or even a single wire. The body of the first and second tension segments **244**, **246** may be substantially wider than the drive screw **256** to uniformly distribute the load. The non-braided version will be more susceptible to fatigue and failure so appropriate materials like nylon may need to be used. As discussed herein in greater detail, the first and second tension segments **244**, **246** are housed within a center molded cavity of the gastric band **21** that allows them to slip with respect to the gastric band **21** so that as they are tightened stress does not build up in the silicone outer sleeve that would tend to wrinkle or fold the outer membrane.

With regard to the drive motor **176**, it is housed within a pocket in the middle of the gastric band **21** and is secured to the first end **234** of the first segment **230** of the ring **22**. The motor housing **258** is grounded and attached to the housing sleeve **260** so that when energy or power is applied; the motor shaft **262** rotates, not the motor housing **258**. The motor housing **258** is attached to a drive screw **267** that is coupled to the opposite first ends **248**, **252** of the first and second tension segments **244**, **246**. If one polarity is applied, the motor shaft **262** rotates in a first direction and the system is tightened drawing the first ends **248**, **252** of the respective first and second tension segments **244**, **246** toward one another. If the opposite polarity is applied, the motor shaft **262** rotates in a second direction opposite to the first direction and the system loosens, pushing the first ends **248**, **252** of the respective first and second tension segments **244**, **246** away from one another. The drive thread configuration can be changed to allow for different speed or torque ratios of the motor to the linear travel of the screws. This will also prevent back travel when the motor is not energized due to the inertia within the motor itself. Additionally, if power is always present, it is contemplated active braking could be incorporated by applying the same polarity to both poles of the motor thereby increasing its holding strength, although usage of power for braking might not be practical in certain application as it would consume power more quickly. It is further contemplated this could also be achieved passively by using a stepper motor which would inherently braking when power is removed.

In accordance with an alternate embodiment as shown with reference to FIG. **34**, a tightening nut **261** is rotated around the outside of the first and second tension segments **244**, **246** and has a worm gear **263** coupled to the motor (not shown). The worm gear **263** prevents back travel and forces cannot be passed from the tension segments **244**, **246** back to the motor if the motor is not moving the disclosed worm gear configuration. Rotation in either direction by the motor drive shaft **265** linearly moves the screw head ends **248'**, **252'** of the first and second tension segments **244**, **246** towards each other or away from each other since the first and second tension segments **244**, **246** are not actually rotated. It is contemplated the threading on the ends of the first and second tension segments

may not be circumferential but only on one side. This would improve guidance and prevent slipping of the threads.

It is further contemplated the screw ends could be connected to drive cables forming the tension segments by crimping the metal thread end to the drive cable, or it could be overmolded plastic if the resulting threading was strong enough to work in conjunction with the drive. It could also be molded in the system as a hole with long fiber filler added to the plastic to improve its tension capabilities.

Referring to FIG. **35**, and in accordance with another drive structure for use in accordance with the system described with reference to FIGS. **32** and **33**, a drive **266** with an angled beveled gearing surface is connected to a motor **176** which is in turn connected to the outer portion of a gastric band **21**. In this configuration, angled racks **268**, **270** are formed along the first ends **248**, **252** of the first and second tension segments **244**, **246** of the gastric band **21**. As the motor **176** rotates, both ends **248**, **252** of the first and second tension segments **244**, **246** of the gastric band **21** are drawn inward at the same speed if the motor **176** were to rotate in a first direction, for example, counterclockwise orientation, and the gastric band **21** is uniformly tightened.

With reference to FIG. **36**, it is contemplated the beveled gearing surface of the drive **266** may be oriented at a 90° angle from the above embodiment such that the angled racks **268**, **270** are drawn over top of one another. The angled racks **268**, **270** in these embodiments require a track with low friction by which they can travel linearly with respect to each other. This track would also ensure that there is a solid connection to the beveled gear and that no slippage occurs.

In accordance with an alternate embodiment, and with reference to FIG. **37**, the angled racks **268**, **270** (shown above with reference to FIGS. **35** and **36**) are replaced by high strength cables **272**, **273** and connected directly around a motor shaft **269** in a manner similar to a winch system. The alternative could reduce the complexity of the design as the cables would not require tight tolerances and there would be no concern that the racks could slip from the winch.

In accordance with yet another embodiment, and with reference to FIG. **38**, the motor **176** is external to the gastric band **21** and has a flexible drive cable **274** that rotates any internal gears, racks, pinions, etc. (shown with reference to the drive of FIG. **33**, although other drive systems are contemplated). The drive cable **274** is capable of providing adequate torque to the drive screw **264** in order to tighten the gastric band **21**. The flexible cable drive would be similar to that found on the Johnson & Johnson Mammotome™ MR product. This flexible drive cable could be implemented into several other embodiments as well when coupled with the appropriate hardware at each of the ends.

While the drive element **35** of the present ring **22** is robust and not prone to failure, it may at times be necessary to release the tension element **32** in an emergency. The release of the tension element **32** would provide for immediate release of tension applied by the ring **22** to the stomach and permit removal of the ring **22** from its position about the stomach.

In accordance with a first embodiment of a tension element release system and with reference to FIGS. **39**, **40** and **41**, the tension element **32** includes a free end **34** and a fixed end **33**. The fixed end **33** is secured adjacent the first end **26** of the ring **22** via a release mechanism **312** allowing selective release of the fixed end **33** of the tension element **32** from the first end of the ring **22** for release of tension being applied by the ring **22**. The release mechanism **312** includes a jaw mechanism **314** that selectively engages the fixed end **33** of the tension element **32**. The fixed end **33** is provided with a bulbous head **316**

that is selectively seated within the jaw mechanism **314** in the manner discussed below in greater detail.

The jaw mechanism **314** includes a fixed jaw member **318** and a movable jaw member **320**. A jaw drive element **322** is positioned between the fixed jaw member **318** and the movable jaw member **320**. The fixed jaw member **318** is substantially L-shaped and includes a first leg **324** and a second leg **326** oriented perpendicular to each other. Similarly, the movable jaw member **320** is substantially L-shaped and includes a first leg **328** and a second leg **330** oriented perpendicular to each other. The fixed jaw member **318** and the movable jaw member **320** sit facing each other in a mirror like orientation with the first legs **324**, **328** of the respective fixed jaw member **318** and the movable jaw member **320** substantially parallel to each other and the second legs **326**, **330** of the respective fixed jaw member **318** and the movable jaw member **320** facing each other in an aligned manner. By adopting this orientation, the fixed jaw member **318** and the movable jaw member **320** create a cavity in which the enlarged head **316** of the tension element **32** may sit while the remainder of the tension element **32** extends through the opening **332** formed between the free ends **334**, **336** of the respective second legs **326**, **330** of the fixed jaw member **318** and movable jaw member **320**. As will be appreciated based upon the following disclosure, a spring **321** biases the movable jaw member **320** toward the fixed jaw member **318** maintaining the free ends **334**, **336** of the respective second legs **326**, **330** of the fixed jaw member **318** and movable jaw member **320** in proximity to each other for holding the enlarged head **316** of the tension element **32** until it is desired to release the tension element **32**.

When one desires to release the tension element **32**, that is, release the enlarged head **316** of the tension element **32** from its position between the fixed jaw member **318** and the movable jaw member **320**, the jaw drive element **322** is expanded in a manner pushing the movable jaw member **320** away from the fixed jaw member **318**. As the movable jaw member **320** is pushed away from the fixed jaw member **318**, that is, as the jaw mechanism **314** is moved from its locked orientation with the fixed jaw member **318** and movable jaw member **320** in close proximity to its release orientation with the fixed jaw member **318** and movable jaw member **320** moved away from each other, the opening **332** therebetween expands until it is larger than the enlarged head **316** of the tension element **32** at which time the fixed end **33** of the tension element **32** is released from its position between the fixed jaw member **318** and the movable jaw member **320**.

In accordance with a preferred embodiment, the jaw drive element **322** is a balloon **338** which may be selectively expanded for engagement with the fixed jaw member **318** and the movable jaw member **320** in a manner selectively moving the fixed jaw member **318** and the movable jaw member **320** to their release orientation. While a particular jaw drive element **322** is disclosed above in accordance with a preferred embodiment of the present invention, it is contemplated other drive element mechanisms may be employed without departing from the spirit of the present invention.

For example, and in accordance with an alternate embodiment shown with reference to FIGS. **42** and **43**, the jaw drive element **322** might take the form of a balloon **338** secured to the fixed jaw member **318**, which upon expansion presses against the movable jaw member **320** to place the jaw mechanism **314** in its release orientation. It is contemplated such a balloon **338** would be constructed of silicone and be supplied with fluid for expansion via a catheter **339** extending along the present apparatus.

Another jaw drive element **322'** is shown with reference to FIGS. **44** and **45**. In accordance with this embodiment, a

shape memory alloy spring **340** is positioned between the fixed jaw member **318** and the movable jaw member **320**. The spring **340** is linked to a source of electricity **342**. Upon application of the a voltage across the spring **340**, the spring **340** will change shape, for example, and in accordance with a preferred embodiment, expand, forcing the fixed jaw member **318** and movable jaw members **320** apart in a manner moving the jaw mechanism **314** to its release orientation.

In accordance with an alternate embodiment as shown with reference to FIGS. **46-48**, the jaw mechanism **314** includes a first movable jaw member **320a** and a second movable jaw member **320b**. The first movable jaw member **320a** and the second movable jaw member **320b** are pivotally connected with first and second spring biasing members **344a**, **344b** forcing them toward one another. A jaw drive element **322** is positioned between the first movable jaw member **320a** and the second movable jaw member **320b**.

The first movable jaw member **320a** is substantially L-shaped and includes a first leg **324a** and a second leg **326a** oriented perpendicular to each other. Similarly, the second movable jaw member **320b** is substantially L-shaped and includes a first leg **324b** and a second leg **326b** oriented perpendicular to each other. Each of the first and second movable jaw members **320a**, **320b** include a laterally extending flange **346a**, **346b** through which a pivot pin **348** extends for pivotally linking the first movable jaw member **320a** to the second movable jaw member **320b** in a manner described above. The first movable jaw member **320a** and the second movable jaw member **320b** sit facing each other in a mirror like orientation with the first legs **324a**, **324b** of the respective first and second movable jaw members **320a**, **320b** substantially parallel to each other and the second legs **326a**, **326b** of the respective first and second movable jaw members **320a**, **320b** facing each other in an aligned manner. By adopting this orientation, the first and second movable jaw members **320a**, **320b** create a cavity in which the enlarged head **316** of the tension element **32** may sit while the remainder of the tension element **32** extends through the opening **332** formed between the free ends **334**, **336** of the respective second legs **326a**, **326b** of the first and second movable jaw members **320a**, **320b**. As will be appreciated based upon the following disclosure, the first and second movable jaw members **320a**, **320b** are biased toward each other maintaining the free ends **334**, **336** of the respective second legs **326a**, **326b** of the first and second movable jaw member **320a**, **320b** in proximity to each other for holding the enlarged head **316** of the tension element **32** until it is desired to release the tension element **32**. When one desires to release the tension element **32**, that is, release the enlarged head **316** of the tension element **32** from its position between the first and second movable jaw members **320a**, **320b**, the jaw drive element **322** is expanded in a manner pushing the first and second movable jaw members **320a**, **320b** away from each other. As the first and second movable jaw members **320a**, **320b** are pushed away from each other, that is, as the jaw mechanism **314** is moved from its locked orientation with the first and second movable jaw members **320a**, **320b** in close proximity, to its release orientation with the first and second movable jaw members **320a**, **320b** moved away from each other, the opening **332** therebetween expands until it is larger than the enlarged head **316** of the tension element **32** at which time the fixed end **33** of the tension element **32** is released from its position between the first and second movable jaw members **320a**, **320b**.

As with embodiment described above, the jaw drive element **322** is a balloon **338** which may be selectively expanded for engagement with the first and second movable jaw members **320a**, **320b** in a manner selectively moving the first and

second movable jaw members **320a**, **320b** to their release orientation. While a particular jaw drive element is disclosed above in accordance with a preferred embodiment of the present invention, it is contemplated other drive element mechanisms may be employed without departing from the spirit of the present invention. For example, another jaw drive element **322'** is shown with reference to FIGS. **49** and **50**. In accordance with this embodiment a shape memory alloy spring **340** is positioned between the movable jaw members **320a**, **320b**. The spring **340** is linked to a source of electricity **342**. Upon application of a voltage across the spring **340**, the spring **340** will expand forcing the movable jaw members **320a**, **320b** apart in a manner moving the jaw mechanism **314** to its release orientation.

In accordance with yet another embodiment shown in FIGS. **51** and **52**, the fixed end **33** of the tension element **32** is secured in position for selective release via a fracture mechanism **350**. In particular, the fixed end **33** of the tension element **32** is secured to an elongated coupling element **352** extending within a shape memory alloy tube **354**, wherein upon the application of a change in temperature, for example, and in accordance with a preferred embodiment, heating, of the shape memory alloy tube **354**, the tube **354** will expand in a manner fracturing the elongated coupling element **352** and permitting release of the fixed end **33** of the tension element **32**.

The shape memory alloy tube **354** is substantially cylindrical and includes a proximal end **356** and a distal end **358**. The elongated coupling element **352** is shaped and dimensioned to extend within the tube **354** between the proximal end **356** and the distal end **358**. The tube **354** includes a first opening **360** at the proximal end **356** and a second opening **362** at the distal end **358**. The first opening **360** is slightly smaller than the enlarged head **316a** of the coupling element **352** and the enlarged head **316a** is, therefore, shaped and dimensioned to sit upon the ledge **357** defined by the first opening **360**. The second opening **362** of the tube **354** is slightly smaller than the first opening **360**. However, the second end of the coupling element **352** also includes an enlarged head **316b** which is shaped and dimensioned to sit upon the ledge **359** defined by the second opening **362**. As such, the coupling element **352** is held between with first opening **360** of the tube **354** and the second opening **362** of the tube **354** with the enlarged heads **316a**, **316b** of the coupling element **352** sitting outside of the tube **354**. The coupling element **352** is provided with a reduced diameter fracture section **364** located between the enlarged head **316a** at the first end of the coupling element **352** and the enlarged head **316b** at the second end of the coupling element **352**. In accordance with a preferred embodiment of the present invention, the fracture section **364** is located adjacent the second end of the coupling element **352**. The fixed end **33** of the tension element **32** is secured to the coupling element **352** at the second end thereof.

With this construction in mind, a heating coil **366** is positioned about the shape memory alloy tube **354** for selective heating of the shape member alloy tube **354** so as to cause expansion thereof. In practice, when it is desired to release the fixed end **33** of the tension element **32**, the heating coil **366** is supplied with current causing coil **366** to heat. The heat causes expansion of the shape memory alloy tube **354**. The expansion of the shape memory alloy tube **354** results in the application of tension to the coupling element **352**. The applied tension stretches the coupling element **352** along its length as enlarged heads **316a** and **316b** are moved apart, which ultimately results in the fracture thereof at the weakened fracture section **364**. Once the fracture section **364**

breaks, the second end of the coupling element **352** is free to fall away from the tube **354** along with the fixed end **33** of the tension element **32**.

It is also contemplated that cooling could be employed as a mechanism for changing the shape of the elongated tube and the tube may be cooled through the use of a Peltier-cooling element positioned thereabout.

In accordance with a variation of the embodiment described above with reference to FIGS. **51** and **52**, the tension element release system is adapted to allow for fluid filling of the gastric band **21** upon the release of the tension element **32** or failure of the tension element **32**. In accordance with such an embodiment as shown with reference to FIGS. **53**, **54** and **55**, the ring **22** is provided with a secondary cavity **370** that is placed in fluid communication with a fluid source **374** once the tension element is released. The secondary cavity **370** extends along the circumference of the ring **22** and is adapted for filling thereof so as to apply pressure via the application of fluid pressure in manner similar to a conventional balloon based gastric band.

The secondary cavity **370** extends about the length of the ring **22** and the tension element **32** extends within (or adjacent to) the secondary cavity **370** such that when the tension element **32** is release as described below fluid access is provided to the secondary cavity **370** for the inflow of fluid necessary to fill the secondary cavity **370** and maintain the application of pressure by the ring **22**.

As with the embodiment described above with reference to FIGS. **51** and **52**, the fixed end **33** of the tension element **32** is secured in position for selective release via a fracture mechanism. In particular, the fixed end **33** of the tension element **32** is secured to an elongated coupling element **352** extending within a shape memory alloy tube **354**, wherein upon heating of the shape memory alloy tube **354**, the tube **354** will expand in a manner fracturing the elongated coupling element **352** and permitting release of the fixed end **33** of the tension element **32**.

The shape memory alloy tube **354** is substantially cylindrical and includes a proximal end **356** and a distal end **358**. The elongated coupling element **352** is shaped and dimensioned to extend within the tube **354** between the proximal end **356** and the distal end **358**. The tube **354** includes a first opening **360** at the proximal end **356** and a second opening **362** at the distal end **358**. The first opening **360** is slightly smaller than the enlarged head **316a** of the coupling element **352** and the enlarged head **316a** is, therefore, shaped and dimensioned to sit upon the ledge **357** defined by the first opening **360**. The second opening **362** of the tube **354** is slightly smaller than the first opening **360**. However, the second end of the coupling element **352** also includes an enlarged head **316b** which is shaped and dimensioned to sit upon the ledge **359** defined by the second opening **362**. As such, the coupling element **352** is held between the first opening **360** of the tube **354** and the second opening **362** of the tube **354** with the enlarged heads **316a**, **316b** of the coupling element **352** sitting outside of the tube **354**. The coupling element **352** is provided with a reduced diameter fracture section **364** located between the enlarged head **316a** at the first end of the coupling member **352** and the enlarged head **316b** at the second end of the coupling member **352**. In accordance with a preferred embodiment of the present invention, the fracture section **364** is located adjacent the second end of the coupling element **352**. The fixed end **33** of the tension element **32** is secured to the coupling element **352** at the second end thereof.

With this construction in mind, a heating coil **366** is positioned about the shape memory alloy tube **354** for selective heating of the shape member alloy tube **354** so as to cause

expansion thereof. When it is desired to release the fixed end 33 of the tension element 32, the heating coil 366 is supplied with current causing the coil 366 to heat. The heat causes expansion of the shape memory alloy tube 354. The expansion of the shape memory alloy tube 354 results in the application of tension stretching the coupling element 352 along its length as enlarged heads 316a and 316b are moved apart which will ultimately result in the fracture thereof at the weakened fracture section 364. Once the fracture section 364 breaks, the second end of the coupling element 352 is free to fall away from the tube 354 along with the fixed end 33 of the tension element 32.

However, and in addition to the embodiment described above with reference to FIGS. 51 and 52, the coupling element 352 includes a central port 372 connected to a remote fluid source 374 via port 377. The central port 372 extends from the first end of the coupling member 352 to a stop point 375 adjacent the second end of the coupling member 352, but beyond the fracture section 364. As such, when the fracture section 364 is broken as described above, the fluid is free to flow through the coupling element 352, through the second opening 362 of the tube 354 and into the secondary cavity 370 for filling the secondary cavity 370 and supplying the ring 22 with a pressure source for maintaining the application of pressure against the stomach of the user.

Referring to FIGS. 56A, 56B and 56C, yet another embodiment of implementing a balloon based back-up system in conjunction with the mechanical tension offered by the tension element 32 is disclosed. In accordance with such an embodiment, the fixed end 33 of the tension element 32 is secured to the second end 28 of the ring 22 via a release mechanism 312 allowing selective release of the fixed end 33 of the tension element 32 from the second end 28 of the ring 22 for release of tension being applied by the ring 22. The release mechanism 312 includes a jaw mechanism 314 that selectively engages the fixed end 33 of the tension element 32. The fixed end 33 is provided with a bulbous head 316 that is selectively seated within the jaw mechanism 314 in the manner discussed below in greater detail.

The jaw mechanism 314 includes a fixed jaw member 318 and a movable jaw member 320. A jaw drive element 322 is positioned between the fixed jaw member 318 and the movable jaw member 320. The fixed jaw member 318 is substantially L-shaped and includes a first leg 324 and a second leg 326 oriented perpendicular to each other. Similarly, the movable jaw member 320 is substantially L-shaped and includes a first leg 328 and a second leg 330 oriented perpendicular to each other. The fixed jaw member 318 and the movable jaw member 320 sit facing each other in a mirror like orientation with the first legs 324, 328 of the respective fixed jaw member 318 and the movable jaw member 320 substantially parallel to each other and the second legs 326, 330 of the respective fixed jaw member 318 and the movable jaw member 320 facing each other in an aligned manner. By adopting this orientation, the fixed jaw member 318 and the movable jaw member 320 create a cavity in which the enlarged head 316 of the tension element 32 may sit while the remainder of the tension element 32 extends through the opening 332 formed between the free ends of the respective second legs 326, 330 of the fixed jaw member 318 and movable jaw member 320. As will be appreciated based upon the following disclosure, the movable jaw member 320 is biased toward the fixed jaw member 318 maintaining the free ends forming an opening 332 between the fixed jaw member 318 and movable jaw members 320 in proximity to each other for holding the enlarged head 316 of the tension element 32 until it is desired to release the tension element 32.

When one desires to release the tension element 32, that is, release the enlarged head 316 of the tension element 32 from its position between the fixed jaw member 318 and the movable jaw member 320, the jaw drive element 322 is expanded in a manner pushing the movable jaw member 320 away from the fixed jaw member 318. As the movable jaw member 320 is pushed away from the fixed jaw member 318, that is, as the jaw mechanism 314 is moved from its locked orientation with the fixed jaw member 318 and movable jaw member 320 in close proximity, to its release orientation with the fixed jaw member 318 and movable jaw members 320 moved away from each other, the opening 332 therebetween expands until it is larger than the enlarged head 316 of the tension element 32 at which time the fixed end 33 of the tension element 32 is released from its position between the fixed jaw member 318 and the movable jaw member 320.

In accordance with a preferred embodiment, the jaw drive element 322 is a balloon 338 which may be selectively expanded for engagement with the jaw members 318, 320 in a manner selectively moving the jaw members 318, 320 to their release orientation. As will be appreciated with the following disclosure, the proximal end of the jaw mechanism 314 where the balloon 338 is positioned is in fluid communication with a fluid source 374 via a port 377 and the balloon 338 is oriented along the jaw mechanism 314 so as to block the flow of fluid until it is desired. When the balloon 338 is fully expanded for release of the fixed end 33 of the tension element 32 as described above, a needle 376 fixed relative to and extending through the movable jaw member 320 contacts the balloon 338 to rupture the balloon 338. With the rupturing of the balloon 338, a passageway 378 is formed between the remote fluid source 374 and the cavity formed between the fixed jaw member 318 and the movable jaw members 320. The remote fluid source 374 is in fluid communication with the passageway 378 and fluid is free to flow through the jaw mechanism 314 and into the secondary cavity 370 (see FIGS. 53, 54 and 55) for filling the secondary cavity 370 and supplying the ring 22 with a pressure source for maintaining the application of pressure against the stomach of the user.

As discussed above with regard to the embodiments in FIGS. 53, 54 and 55, a fluid source 374 is required for implementation of the embodiment. This fluid source 374 is preferably incorporated into the antenna/controller pod 23. In order to ensure fluid pressure is not applied in an undesirable manner, the fluid source 374 is provided with a fail-safe mechanism for releasing fluid pressure in the event of a malfunction of the tension element and when desired by the operator as discussed below with regard to FIGS. 59-67.

In accordance with a variation on this embodiment, the rupture of the balloon 338 could allow for the release of fluid from the ring 22 facilitating release thereof in conjunction with the release of the tension element 32. This would occur where the fluid source (or in this variation, the fluid reservoir) 374 is empty and the fluid is allowed to flow from a prefilled secondary cavity 370 and to the fluid reservoir 374 rather than the fluid flowing from the fluid source 374 to the secondary cavity 370.

In accordance with an alternate embodiment, and with reference to FIGS. 57A, 57B, 58A and 58B, the flow of fluid from the cavity 370 to the fluid source (or reservoir) 374 may be controlled by an electrically sensitive membrane 375 that is destroyed upon the application of the electricity. Once destroyed the passageway between the fluid reservoir 374 and the cavity 370 of the ring 22 is open allowing for the free flow of fluid.

In accordance with the concept of allowing for the release of fluid held in the secondary cavity 370 of the ring 22, the

fluid reservoir 374 could be an expandable reservoir that expands or contracts to control the volume of fluid (and as such the pressure applied by the ring). Expansion or contraction of the fluid reservoir 374 is controlled by a shape memory alloy actuator 377 that expands or contracts the fluid reservoir 374 based upon the application of electricity (and ultimately the generation of heat therein) thereto via electrical leads 379. Because the fluid reservoir 374 will be in a vacuum relationship with the cavity 370, controlled expansion and contraction of the fluid reservoir 374 will cause fluid to be drawn from or forced into the cavity 370 of the ring 22.

In accordance with an embodiment shown in FIGS. 59, 60 and 61, a fluid source valve 380 is provided along the fluid path to the ring 22. The fluid source valve 380 includes a first chamber 382 in communication with an upstream portion of the fluid source 374 via an inlet 384. The fluid source valve 380 includes a second chamber 386 separated from the first chamber 382 by a valve release membrane 388 formed in a septum 390 separating the first chamber 382 from the second chamber 386. The second chamber 386 includes an outlet 392 leading to a catheter 394 linking the fluid source to the ring 22. When it is desired to allow for the flow of fluid to the ring 22, electrical energy as applied to the valve release membrane 388 destroying the valve release membrane 388 and allowing fluid to freely flow from the inlet 384, through the first chamber 382, the valve release opening 389 and the second chamber 386, and into the outlet 392 for flow through the catheter 394 and into the ring 22.

In accordance with an alternate embodiment, and with reference to FIGS. 62, 63 and 64, the fluid source valve 380 includes a first chamber 382 in communication with an upstream portion of the fluid source 374 via an inlet 384. The fluid source valve 380 includes a second chamber 386 separated from the first chamber 382 by a valve release opening 389 formed in a septum 390 separating the first chamber 382 from the second chamber 386 and in which a resilient plug 400 is positioned. The plug 400 is held in position by upper and lower resilient lips 403a and 403b respectively biasing the plug 400 with the valve release opening 389 in septum 390. The second chamber 386 includes an outlet 392 leading to a catheter 394 linking the fluid source 374 to the ring 22. When it is desired to allow for the flow of fluid to the ring 22, an operator may apply pressure through the skin of a patient to access a flexible upper wall 404 of the first chamber 382 and push the plug 400 from its position within the valve release opening 389 and allow fluid to freely flow from the inlet 384, through the first chamber 382, the valve release opening 389 and the second chamber 386, and into the outlet 392 for flow through the catheter 394 and into the ring 22.

In accordance with yet another alternate embodiment, and with reference to FIGS. 65, 66 and 67, the fluid source valve 380 includes a first chamber 382 in communication with an upstream portion of the fluid source 374 via an inlet 384. The fluid source valve 380 includes a second chamber 386 separated from the first chamber 382 by a valve release opening 389 formed in a wall or septum 390 separating the first chamber 382 from the second chamber 386. A ball 406 is positioned in the second chamber 386 and held in valve release opening 389 by a spring member 402 biasing the ball 406 toward the first chamber 382 and plugging the valve release opening 389. The second chamber 386 includes an outlet 392 leading to a catheter 394 linking the fluid source 374 to the ring 22. When it is desired to allow for the flow of fluid to the ring 22, an operator may apply pressure through the skin of a patient to access a flexible wall 407 of the second chamber 386 and push the spring 402 in a manner releasing the ball 406 from its position within the valve release opening 389 and

allowing fluid to freely flow from the inlet 384, through the first chamber 382, the valve release opening 389 and the second chamber 386, and into the outlet 392 for flow through the catheter 394 and into the ring 22.

In accordance with alternate embodiments as shown with reference to FIGS. 68 and 69, the fixed end 33 of the tension element 32, that is the portion of the tension element 32 secured to the ring 22 such that action of the drive element 35 causes enlargement or reduction in the effective diameter of the tension element 32, is selectively released via a selective connection mechanism. In accordance with a first embodiment as shown with reference to FIG. 68, actuation of a pin 1114 (whether it be by way of shrinking or removal) allows for movement of first and second detent balls 1116, 1118 permitting release of a connection 1120 linking the fixed end 33 of the tension element 32 to the ring 22.

In particular, the fixed end 33 of the tension element 32 is securely held in position relative to the ring 22 based upon the interference fit created between a retaining disk 1121 including a circumferential recess 1125 formed along the inner wall thereof, the first and second detent balls 1116, 1118, the pin 1114 and the connection 1120. With the various components held as shown in FIGS. 68 and 69, the connection 1120 is fixedly held relative to the retaining disk 1121 which is secured to the ring 22. Once the pin 1114 is removed from its position forcing the detent balls 1116, 1118 into the circumferential recess 1125 and sitting within a central cavity 1127 of the connection 1120, the detent balls 1116, 1118 will move centrally (as a result of the tension applied by the tension element 32) and the fixed end 33 of the tension element will be free to move since the interference fit will have been broken.

Referring to FIG. 69, movement of the detent balls 1116, 1118 is further facilitated by the provision of springs 1123 which encourage the detent balls 1116, 1118 to move centrally upon the removal of the pin 1114.

As discussed above, removal of the pin is achieved either physically or by way of shrinking. Where it is desired to shrink the pin 1114, the pin 1114 is preferably composed of a shape memory alloy adapted to shrink sufficiently upon the application of heat to allow for the movement of the detent balls 1116, 1118 from their positioned within the circumferential recess 1125. In accordance with such an embodiment, a heater mechanism composed of a resistive wire (not shown) is coiled about the shape memory alloy pin 1114. The heating coil uses RF energy transferred to the pin 1114 by means of an inductive coupling realized between the antenna/controller pod 23 and an external RF emitter.

Alternately, it is contemplated the pin may be constructed for simply sliding from its position within the central cavity of the connection. In accordance with another embodiment, the pin may be an electro activated polymer based drive element which shrinks by means of an applied voltage and/or current induced in the pin by means of an inductive coupling.

In accordance with a third embodiment as shown with reference to FIGS. 70 and 71, the fixed end 33 of the tension element 32 is selectively secured to the ring 22 by way of a retaining pin 1214. The retaining pin 1214 is fixedly mounted within the ring 22 and engages an aperture 1213 formed in the tension element 32. The retaining pin 1214 is actuated via a mechanically amplified retractable pin assembly 1210. The pin assembly 1210 is secured to the ring 22 and triggered by the motion of a shape memory drive element or a piezoelectric drive element 1226. The mechanically amplified retractable pin assembly 1210 allows the motion necessary for activating the moving retaining pin 1214 to be extremely small (for example, in the hundreds of a micrometer range). The

reduced motion is achieved by means of shape memory alloy or piezoelectric based drive elements.

The embodiment includes a housing **1228** secured to the ring **22** and in which a spring biased retaining pin **1214** is mounted for movement between a lock positioned and a release position. The retaining pin **1214** includes an output pin **1230** shaped and dimensioned for seating within an aperture **1213** formed at the end of the tension element **32**. The retaining pin **1214** further includes a spring flange **1232** which is acted upon by a drive spring **1234** when the shape memory alloy drive element (such as nitinol) **1226** permits movement thereof. More particularly, controlled movement of the retaining pin **1214** is achieved by creating an interference fit between the retaining pin **1214** and the shape memory alloy drive element **1226** by positioning first and second detent balls **1216**, **1218** between the pin **1214** and the drive element **1226**. The drive element **1226** includes a drive element body **1236** having an hourglass shape and moves between a first position (see FIG. **70**) and second position (see FIG. **71**). When the drive element body **1236** is in its first position, the detent balls **1216**, **1218** are forced into an interference position preventing movement of the pin **1214** (see FIG. **70**). However, when the drive element **1226** is heated it breaks a coupling linking it to the base of the housing **1228** and is free to move upwardly under the bias provided by spring **1237** (see FIG. **71**). When the drive element **1226** moves upwardly in this manner, the detent balls **1216**, **1218** are free to move into the narrow section of the drive element body **1236** allowing the detent balls **1216**, **1218** to move from their position interfering with movement of the pin **1214**. Thereafter, the drive spring **1234** moves the pin **1214** to its release position disconnecting the retaining pin **1214**, in particular, the output pin **1230**, from engagement with the tension element **32**.

In summary, the mechanically amplified retractable pin assembly **1210** employs a shape memory alloy drive element **1226** for triggering energy release stored in a loaded compression drive spring **1234**. When in the extended position as shown with reference to FIG. **70**, the pin **1214** is seen to be loaded by the compression drive spring **1234**. The drive spring **1234** remains firmly locked in this position due to the ball lock shown in FIG. **70**. This is made possible by the drive element body **1236** which drives outwardly an array of detent balls **1216**, **1218**. Once actuated however, the spring **1237** drives shape memory alloy drive element **1226** upwardly thereby causing the detent balls **1216**, **1218** to roll inwardly and allowing the pin **1214** to retract under the force of the drive spring **1234**.

Under certain circumstances it may become necessary to release the tension element **32** for emergency removal of the ring **22** from its position around the stomach. As such, and in accordance with a first embodiment as shown with reference to FIGS. **73**, **74**, **75** and **76**, the ring **22**, and in particular, the tension element **32**, is provided with a release pin **512** that allows for release of the free end **34** of the tension element **32** from its secure attachment position relative to the ring **22**. The release pin **512** transversely extends through the ring **22** at a position adjacent to the fixed end **33** of the tension element **32**. As a result, when the release pin **512** extends through the ring **22** and is in engagement with the fixed end **33** of the tension element **32**, the tension element **32** is securely held in position for contraction and expansion of the ring **22** as discussed herein. However, when the release pin **512** is pulled from its position along the ring **22** and out of engagement with the fixed end **33** of the tension element **32**, the fixed end **33** of the tension element **32** is released for free movement within the ring **22** (see FIGS. **74** and **76**). As such, the tension created

between the free end **34** of the tension element **32** and the fixed end **33** of the tension element **32**, which ultimately allows for a reduction in the effective size of the ring **22**, is released and the ring **22** is allowed to return to its unbiased large diameter configuration. Once in this large diameter configuration, the ring **22** may be readily removed from its position about the stomach of the patient.

In accordance with an alternate embodiment, and with reference to FIGS. **77** and **78**, the nut **60** of the drive element **35** is replaced with a slip nut **60** that allows for selective release of the free end **34** of the tension element **32** from its position within the drive element **35**. More particularly, the slip nut **60** allows the threaded free end **34** of the tension element **32** to slip past the drive nut **60** when necessary to allow the band restriction to be released if the motor **66** fails to operate. The slip nut **60** has the advantage of being either spring **103** loaded to release at a known pull force of the threaded screw (see FIG. **77**) or the slip nut **60** could be normally closed and a linkage **63** is provided that could be activated at the antenna/controller pod **23** (see FIG. **78**).

Referring now to the embodiment presented with reference to FIG. **77**, the nut **60** is spring-loaded for release of the threaded free end **34** of the tension element **32** at a known pull force. More specifically, a slip nut **60** is a nut formed in multiple pieces which are held together via springs or other means. FIG. **77** shows the slip nut **60** spring loaded to open at a desired pull force on the threaded free end **34** of the tension element **32**. Springs by design provide force greater than the forces generated under normal conditions when food is swallowed, but if the band is stretched circumferentially by using an esophageal dilator the force overcomes the springs and the threaded free end **34** slips through the nut **60** relaxing the restriction. FIG. **78** shows the slip nut **60** wherein multiple pieces are held together with a linkage **63** that terminates in the antenna/controller pod **23** for disengaging the nut **60** from the threaded free end **34**. The termination of the linkage **63** could be activated by a simple toggle **516**. FIG. **79** shows this toggle **516** and also provides a sketch of the linkage termination. The simple push pull design allows a doctor to make an incision in the skin to access the toggle **516**. A further improvement would be to provide a button, or some means of activating the linkage without cutting the skin to access the release mechanism. In implementing such an embodiment, it is contemplated the button would be spring loaded such that upon access to the button with, for example, a hypodermic needle, pushing the button releases the spring and thereby activates the linkage release mechanism.

With reference to the embodiment shown in FIG. **79**, the split nut **60** is activated for release through actuation of a button **518** at the antenna/controller pod **23**. This embodiment overcomes the need for access into the patient's abdomen and could be activated without the need for incisions. If an emergency situation presented itself the patient could have a small incision made above the antenna/controller pod **23** on the sternum and the fail-safe linkage **63** could be activated directly. This would allow the device to be replaced at a later date, or troubleshoot the device and possibly replace the antenna/controller pod **23** in a subcutaneous procedure without needing to remove the entire implant.

Another embodiment for the release of the threaded free end **34** of the tension element **32** is shown with reference to FIGS. **80** and **81**. This embodiment includes a nut **60** construction that improves upon the nut's ability to engage and disengage simply. The use of an elliptical nut **60** that pivots on an axis perpendicular to the axis of the threaded free end **34** of the tension element **32** allows for easy engagement and disengagement of the threaded free end **34** of the tension element

32. This embodiment also utilizes a linkage 63 from the antenna/controller pod 23 and a switch/toggle 516 to pull the threaded free end 34 of the tension element 32 for disengagement. The nut 60 is spring loaded via spring 517 to provide positive displacement for the nut 60 to engage the threads of the threaded free end 34 of the tension element 32 when the fail-safe is not engaged. FIG. 80 shows the elliptical nut 60 in the engaged position and FIG. 81 shows the elliptical nut 60 in the fail-safe disengaged position. In FIG. 81, the linkage wire 63 that is connected to the antenna/controller pod 23 is moved to a position for fail-safe release of the threaded free end 34 of the tension element 32, which causes the elliptical nut 60 to move and release from the threaded free end 34.

In accordance with yet another embodiment as shown with reference to FIG. 82, an antenna/controller pod 23 that utilizes a magnetic deactivation function is disclosed. This requires a magnetic coil or magnetic emitting antenna 522 to be placed over the antenna 83 of the antenna/controller pod 23 and the oscillating electromagnetic field deactivates the device electronically. That is, the magnetic field induces a reverse polarity in the antenna/controller pod 23, which in turn reverses the voltage sent to the motor 66. This back drives the motor 66 without the use of the control pod in case of an electrical failure in the controller pod, but the motor was still operable. The controller pod would have a secondary circuit to allow the oscillating magnetic field coupling to generate a sufficient amount of power to drive the motor in a given direction. In this case, the desire would be to rotate the motor such that the pressure around the tissue is relieved. MRI sensitivity should not be an issue as an MRI generates a very high intensity permanent field (which will not generate a voltage in a magnetic coil or magnetic emitting antenna) and a very low intensity oscillating electromagnetic field (which will not generate a significant voltage since it is low intensity). The technical challenges of providing enough energy to the implant to reverse the voltage to the motor 66 is also challenged if the wires from the antenna/controller pod 23 becomes detached from the motor 66 or antenna/controller pod 23 itself. FIG. 82 shows the magnet over the antenna 83 providing energy to reverse the motor 66.

Referring now to other embodiments for release of the threaded free end 34 of the tension element 32. In FIGS. 83, 84 and 85, the drive nut 60 has a split construction and is composed of four distinct elements 560a, 560b, 560c, 560d forming a central aperture 524 through which the threaded free end 34 of the tension element 32 passes for threaded driving as discussed above. A driving gear 526 is secured to the outer surface 528 of the nut 60 and drives it in a circular configuration as described above. However, the drive nut 60 is resilient and is adapted for biasing such that the threads 530 formed along the inner surface of the nut 60 disengage from threads 532 formed along the external surface 534 of the free end 34 of the tension element 32. In particular, each of the nut elements 560a-d making up the nut 60 has a C-shaped cross sectional profile as shown with reference to FIGS. 83 and 85. The C-shaped profile includes a first plate member 536 and a second plate member 538 connected by a central connecting member 540. The central connecting member 540 also functions as a part of the inner surface 542 of the aperture 524 through which the fixed end 33 of the tension element 32 passes. The connecting member 540 is provided with a weakened portion 544. As such, when pressure is applied to the first plate member 536 in a direction toward the second plate member 538, the first plate member 536 will then move downwardly toward the second plate member 538 causing the connecting member 540 to move from its normal orientation relative to the second plate member 538 and form an acute

angular relationship with respect to the second plate member 538. By applying pressure to all of the first plate members 536 of the respective nut elements 560a-d simultaneously, the inner threads 530 along the nut 60 are moved away from the free end 34 of the tension element 32 thereby providing for release and free movement of the tension element 32 relative to the nut 60.

In accordance with a preferred embodiment, pressure is applied to the first plate member 536 of the respective nut elements 560a-d through the utilization of a plurality of pressure application plates 546. Each of these pressure application plates 546 includes a resilient balloon 548 which may be expanded upon application of fluid pressure thereto. Since the pressure application plates 546 are formed so as to be positioned directly adjacent the first plate members 536 of the respective nut elements 560a-d, when a balloon 548 is expanded, the balloon 548 will expand into contact with the first plate member 536 of the nut element 560a-d pushing it toward the second plate member 538 of the nut element 560a-d and causing the connecting member 540 to angle away from the free end 34 of the tension element 32 as described above.

In accordance with yet another embodiment of the present invention, and with reference to FIGS. 86, 87 and 88, the nut 60 is provided with flanges 550 upon which the internal threading 530 of the aperture 554 is positioned. These flanges 550 are secured to the nut 60 for controlled movement relative thereto. In particular, and with reference to FIG. 86, when the nut 60 and in particular, the flanges 550, are intended for engagement with threading 530 formed along the outer surface 534 at the free end 34 of the tension element 32, the flanges 550 are oriented substantially normal to the plane in which the nut 60 lies. As such, and when in this configuration, the internal threading 552 along the flanges 550 engages the threading 532 at the free end 34 of the tension element 32 and rotation of the nut 60 causes the threaded free end 34 to be moved relative to the nut 60 for drawing the tension element 32 through the nut 60.

However, the rear outer surface 556 of each flange 550 is provided with a resistive heating element 558 that is connected to an electrical coil 560 secured along the back surface 562 of the outer periphery 564 of the nut 60. As such, when electricity is applied to the coils 560, the resistive heaters 558 are actuated heating the flanges 550. The flanges 550 are constructed such that when they are heated, or otherwise encounter a change in temperature, they will bend away from the free end 34 of the tension element 32 forming an acute angle with the plane in which the nut 60 lies (see FIG. 88). Once in this configuration, and with reference to FIG. 88, the free end 34 of the tension element 32 is free to move relative to the nut 60 for free movement of the tension element 32 relative thereto.

Referring now to FIGS. 89, 90 and 91, yet another embodiment for release of the tension element 32 is disclosed. In accordance with this embodiment, the fixed end 33 of the tension element 32 is secured to a two-bar linkage 566. When the tension element 32 is intended for utilization in constriction of the stomach, the two-bar linkage 566 is folded so that the links 568, 570 nearly overlap (see FIG. 89). When the band 21 needs to be released in an emergency, the two-bar linkage 566 is actuated via a pull lever 567 (see FIG. 91) so as to pull the two bar linkage 566 from its folded configuration and into an extended configuration (see FIG. 90). With the two bar linkage 566 in an extended configuration, the effective length of the tension element 32 is increased providing additional diameter within the ring 22 and allowing the gastric band 21 to be moved from its position along the stomach.

Referring now to FIGS. 92, 93 and 94, a compression, friction drive assembly 572 is utilized for pulling the tension element 32. The friction drive assembly 572, however, includes a release member 574 which moves the opposed rollers 576, 578 of the friction drive assembly 572 apart from each other allowing for free movement of the tension element 32 within the ring 22. Controlled movement of the release member 574 is achieved via the utilization of a pull wire 580 which, when acted upon, forces the rollers 576, 578 of the friction drive assembly 572 apart against the bias of the spring 577 that biases them toward the tension element 32, permitting free movement of the tension element 32. In accordance with a preferred embodiment, and with reference to FIG. 94, movement of the wire 580 is controlled by a screw mechanism 579 that may be selectively acted upon with, for example, a hex wrench 581, to loosen or tighten the wire 580.

In accordance with yet another embodiment of the present invention, and with reference to FIG. 95, the antenna/controller pod 23 is provided with an access port 582 providing a medical practitioner with access to the control electronics of the antenna/controller pod 23 for control thereof in the event of failure. In accordance with such an embodiment a needle 584 would access the access port 582 so as to act like a contact that would either flex contacts 586, 588 or just bridge the contacts 586, 588 to run the motor 66 in the direction to open the gastric band 21 to a maximum diameter thereby relieving any pressure applied by the gastric band 21. For such a method to work, the antenna/controller pod 23 is provided with a battery 590 having a shelf life, for example, of ten or more years, and with enough power to store energy to power the gastric band 21 for a reasonable length of time. Since there is a battery 590 provided with the antenna/controller pod 23, telemetry could be used via wireless technology such as Bluetooth and could allow a patient to self adjust the gastric band 21 without the need for a power module. It is further contemplated rechargeable batteries may be employed and recharging may be achieved on a regular basis via a power unit at a doctor's office or while the patient is sleeping so that more benefits could come from the ability to non-invasively adjust the band.

In accordance with a variation on the embodiment disclosed with reference to FIG. 95, the antenna/controller pod 23 is provided with dual access ports 582a, 582b linked to the printed circuit band 583. As such, and when emergency situations arise under circumstances where the antenna/controller pod 23 does not have sufficient power, the two needles 584a, 584b applied to the first and second ports 582a, 582b of the antenna/controller pod 23 are charged to supply power to the antenna/controller pod 23. In accordance with this embodiment, the first and second ports 582a, 582b are provided with self-healing elastomeric targets 592a, 592b for needle placement.

As briefly discussed above, the needles 584a, 584b are charged. As such, the needles 584a, 584b are connected to a power source 594 that is readily available in a hospital. When the needles 584a, 584b are contacting the conductors 586, 588 in the printed circuit board 583 of the antenna/controller pod 23, the motor 66 will run in the opening direction and the diameter of the gastric band 21 is increased to eliminate any pressure applied by the gastric band 21.

The gastric band 21 would then return to normal operating conditions when appropriate and can be used as designed in accordance with the principles of the present invention. The present embodiment would also function for its intended purpose in the event the printed circuit board failed provided

the emergency electrical path employed in accordance with this embodiment is not part of the operating circuitry of the printed circuit board.

Ring Closure System

With respect to FIGS. 97A and 97B, a preferred embodiment of the clip 27 for securing the gastric band 21 in the closed position is described. The clip 27 on the first end 26 of the ring 22 includes an aperture 70, a tab 71 having a hinge 72 and a slot 73. The aperture 70 is dimensioned to accept the second end 28 therethrough, while the slot 73 is dimensioned to accept the flange 74 disposed on the second end 28.

To close the ring 22, the clip 27 is grasped by the tab 71 and the tag 25 of the antenna/controller pod 23 (see FIG. 1) is inserted through the aperture 70. The clip 27 is then pulled toward the second end 28 so that the housing 29 passes through the aperture 70 while the housing 29 is grasped with atraumatic forceps; the conical shape of the housing 29 facilitates this action. Force is applied to the tab 71 until the slot 73 captures the flange 74, thereby securing the ring 22 in the closed position. The physician may subsequently choose to disengage the slot 73 from the flange 74 by manipulating the tab 71 using laparoscopic forceps, for example, to reposition the ring 22. Advantageously, however, forces inadvertently applied to the tab 71 in an opposite direction will cause the tab 71 to buckle at the hinge 72, but will not cause the flange 74 to exit the slot 73. Accordingly, the hinge 72 of the tab 71 prevents accidental opening of the clip 27 when the tab 71 is subjected to forces that cause the tab 71 to fold backwards away from the housing 29, such as may arise due to movement of the patient, the organ, of or bolus of fluid passing through the organ.

As discussed above, it may at times become necessary to release the pressure applied by the gastric band 21. With this in mind, and in accordance with yet another embodiment as shown with reference to FIGS. 98 and 99, the first and second ends 26, 28 of the gastric band 21 are provided with a mechanism allowing release from their locked positions via a remote latch unlock mechanism 1310. In particular, the clip 27 holding the first and second ends 26, 28 of the gastric band 21 together is released via a variety of electromechanical mechanisms. For example, actuation of an emergency release button (not shown) on the antenna/controller pod 23 will cause release of the clip 27. When the button triggers a communication, a voltage is applied on a flange actuator 1314 by the electronics of the antenna/controller pod 23. The temperature of the actuator 1314 then increases and this triggers movement of the flange 74 toward the inside of the gastric band 21 until the band clip 27 is released (for example, via a shape memory alloy actuator or a bimetallic actuator). Such an embodiment, might allow for treatment without the patient visiting the hospital or other treatment center. The unit might be activated via modem or Internet connection by the surgeon.

Antenna/Controller Pod

With respect to FIGS. 100 and 101, the antenna/controller pod 23 of the present banding system is described. The antenna/controller pod 23 is disposed at the distal end of the antenna cable 24 and includes the removable tag 25 and holes 75. The tag 25 comprises a grip structure that facilitates manipulation and placement of the antenna/controller pod 23 during implantation; after which the tag 25 is removed using a scissors cut. The tag 25 also includes hole 25b that allows the use of a suture thread to assist in passing the antenna/controller pod 23 behind the stomach. The holes 75 also are dimensioned to be compatible with standard suture needles from size 1-0 to 7-0 to permit the antenna/controller pod 23 to be sutured to the patient's sternum, thereby ensuring that the

antenna/controller pod **23** remains accessible to the external antenna **14** and cannot migrate from a desired implantation site.

As shown in FIG. **101**, the antenna/controller pod **23** encloses a printed circuit board **76** that carries the antenna **83** and microcontroller circuitry of the gastric band **21**. The antenna **83** receives energy and commands from the external control **10** (see FIG. **1**), and supplies those signals to the microcontroller, which in turn powers the motor **66** of the drive element **35**. The circuitry of the antenna/controller pod **23** uses the energy received from the incoming signal to power the circuit, interprets the commands received from the external control **10**, and supplies appropriate signals to the motor **66** of the drive element **35**. The circuit also retrieves information regarding operation of the motor **66** of the drive element **35** and relays that information to the external control **10** via the antenna **83**. The circuit board preferably is covered with a water-resistant polymeric covering, e.g., Parylene, to permit use in the high (up to 100%) humidity environment encountered in the body.

The antenna/controller pod **23** includes a mechanical closure system that is augmented by silicone glue so that the pod is fluid tight. This silicone glue also is used to protect soldered wires **79** from humidity. The antenna/controller pod **23** preferably is small, e.g., 16 mm×33 mm×4 mm, to ensure compatibility with a standard 18 mm trocar and so as to be compatible with placement on the sternum. The antenna/controller pod **23** preferably has a smooth, atraumatic shape to avoid tissue damage, has good mechanical strength to withstand handling with surgical graspers and to prevent mechanical deformation to the printed circuit board, and has good electromagnetic permeability to allow efficient energy transmission through the antenna/controller pod **23**. The antenna/controller pod **23** preferably has a relatively thin planar configuration to avoid rotation of the antenna/controller pod **23** when placed under the skin, and may include holes that permit the antenna/controller pod **23** to be sutured in position.

With respect to FIG. **102**, the antenna cable **24** is shown in cross-section. The antenna cable **24** preferably is a coaxial shielded cable encapsulated in a silicone tube **77** to provide biocompatibility. The tube **77** is selected to provide leak-proof encapsulation, with sufficient strength to permit the antenna cable **24** to be manipulated with atraumatic graspers. The braided shield **78** of the antenna cable **24** prevents longitudinal deformation of the antenna cable **24**, and surrounds five helically wound insulated wires **79**. Four of the wires **79** are used to supply power to the micromotor of the drive element **35**; the remaining wire and braided shield **78** are used to supply a signal from the reference position switch to the controller.

As discussed above with respect to FIG. **1**, the gastric band **21** according to the present invention provides an integrated system for regulating food ingestion in the stomach of a patient, wherein variation of the diameter of the ring **22** may be adjusted without any invasive surgical intervention. To accomplish this, the drive element **35** is linked to the subcutaneous antenna/controller pod **23** to receive a radio frequency control and power signal. In accordance with a preferred embodiment, the motor **66** of the drive element **35** has no internal energy supply, but rather is powered by the receiving circuit of the antenna **83** through a rechargeable energy storage device, such as a capacitor. In particular, the receiving circuit converts radio frequency waves received from the external control **10** via the antenna into a motor control and power signal. In accordance with an alternate embodiment, it

is contemplated the drive element may be driven via an implantable rechargeable battery.

Power and Control Circuitry

Referring to FIG. **103**, a preferred embodiment of the circuitry employed in the external control **10** and the gastric band **21** of the present invention is described, based on the principle of passive telemetry by FM-AM absorption modulation. The external control **10** is shown on the left hand side of FIG. **18**, and includes a microprocessor **80** coupled to the control panel **12** and the display screen **13** (see FIG. **1**). The external control **10** produces a signal comprising one or more data bytes to be transmitted to the implantable antenna/controller pod **23** and the drive element **35**.

The external control **10** includes a modulator **81** for amplitude modulation of the RF wave from the RF generator **82**, which signal is emitted by the external antenna **14**. The emitted wave is received by the antenna **83** in the antenna/controller pod **23**, where the AM demodulator **84** extracts the data bytes from the envelope of received RF signal. The data bytes then are decoded and written into an EEPROM of the microcontroller **85**. A special code is used that allows easy decoding of the data by the microcontroller **85**, but also provides maximal security against communication failure.

An external oscillator **86**, which is a voltage controlled oscillator (VCO), provides a clock signal to the microcontroller **85**. The external oscillator **86** may consist of, for example, a relaxation oscillator comprising an external resistor-capacitor network connected to a discharging logic circuitry already implemented in the microcontroller or a crystal oscillator comprising a resonant circuit with a crystal, capacitors and logic circuits. The former solution requires only two additional components, is suitable when the stability of the frequency is not critical, and has low current consumption; the latter solution provides a more stable frequency, but requires a greater number of additional components and consumes more power. The external oscillator **86** preferably comprises the external RC network, due to its simplicity.

The microcontroller **85** interprets the received instructions and produces an output that drives the motor **66** of the drive element **35**. As discussed above, the drive element **35** comprises a bi-directional stepper motor **66** that drives the nut **60** through a series of reducing gears. Preferably, the two coils of the stepper motor **66** of the drive element **35** are directly connected to the microcontroller **85**, which receives the working instructions from the demodulator **84**, interprets them and provides the voltage sequences to the motor coils. When the supply of voltage pulses to the stepper motor **66** stops, the gears are designed to remain stationary, even if a reverse torque or force is applied to the nut **60** by the tension element **32**.

As also described above, use of a stepper motor **66** in drive element **35** makes it possible to obtain positional information on the nut **60** and the tension element **32** without the use of sensors or encoders, because the displacement of the tension element **32** is proportional to the number of pulses supplied to the stepper motor coils. Two signals are employed to ensure precise control, reference position signal S_{RP} , generated by the reference position switch of FIG. **13**, and the drive element signal S_A .

According to one preferred embodiment, signal S_A is the voltage signal taken at one of the outputs of the microcontroller **85** that is connected to the motor coils of the drive element **35**. Alternatively, signal S_A could be derived from the current applied to a motor coil instead of the voltage, or may be an induced voltage on a secondary coil wrapped around one of the motor coils of the drive element **35**. In either case, signal S_A is a pulsating signal that contains information on the num-

ber of steps turned by the rotor and further indicates whether blockage of the mechanism has occurred. Specifically, if the rotor of the stepper motor fails to turn, the magnetic circuit is disturbed, and by induction, affects signal S_A , e.g., by altering the shape of the signal. This disturbance can be detected in the external control, as described below.

Signals S_A and S_{RP} are converted into frequencies using the external oscillator **86**, so that the voltage level of signal S_A applied to the external oscillator **86** causes the oscillator to vary its frequency F_{osc} proportionally to the signal S_A . Thus, F_{osc} contains all the information of signal S_A . When the crimped cap **45** and the tension element **32** are in the reference position (that is, the ring **22** is fully open), the reference position switch produces reference position signal S_{RP} . Signal S_{RP} is used to induce a constant shift of the frequency F_{osc} , which shift is easily distinguishable from the variations due to signal S_A .

If the external oscillator **86** is a relaxation oscillator, as described above, signals S_A and S_{RP} modify the charging current of the external resistor capacitor network. In this case, the relaxation oscillator preferably comprises an external resistor-capacitor network connected to a transistor and a logic circuit implemented in the microcontroller **85**. With S_A and S_{RP} , the goal is to modify the charging current of the capacitor of the RC network to change the frequency of the relaxation oscillator. If the charging current is low, the voltage of the capacitor increases slowly and when the threshold of the transistor is reached, the capacitor discharges through the transistor. The frequency of the charging-discharging sequence depends on the charging current.

If the external oscillator **86** is a crystal oscillator, signals S_A and S_{RP} modify the capacitor of the resonant circuit. In this case, the crystal oscillator circuit preferably comprises a crystal in parallel with capacitors, so that the crystal and capacitors form a resonant circuit which oscillates at a fixed frequency. This frequency can be adjusted by changing the capacitors. If one of these capacitors is a Varicap (a kind of diode), it is possible to vary its capacitance value by modifying the reverse voltage applied on it, S_A and S_{RP} can be used to modify this voltage.

In either of the foregoing cases, signals S_A and S_{RP} are used to modify at least one parameter of a resistor-capacitor (RC) network associated with the external oscillator **86** or at least one parameter of a crystal oscillator comprising the external oscillator **86**.

Referring still to FIG. **105**, signals S_A and S_{RP} , derived from the stepper motor or from the output of the microcontroller **85**, may be used directly for frequency modulation by the external oscillator **86** without any encoding or intervention by the microcontroller **85**. By using the external oscillator **86** of the microcontroller **85** as part of the VCO for the feedback signal, no additional components are required, and operation of the microcontroller **85** is not adversely affected by the changes in the oscillator frequency F_{osc} . The oscillating signal F_{osc} drives the voltage driven switch **87** for absorption modulation, such that feedback transmission is performed with passive telemetry by FM-AM absorption modulation.

More specifically, signal F_{osc} drives the switch **87** such that during the ON state of the switch **87** there is an increase in energy absorption by the RF-DC converter **88**. Accordingly, therefore the absorption rate is modulated at the frequency F_{osc} and thus the frequency of the amplitude modulation of the reflected wave detected by external control **10** contains the information for signal S_A . As discussed below, a pickup **89** in the external control **10** separates the reflected wave where it can be decoded by FM demodulation in the demodulator **90** to

obtain signal S_A' . This method therefore allows the transmission of different signals carried at different frequencies, and has the advantage that the ON state of the switch **87** can be very short and the absorption very strong without inducing an increase in average consumption. In this way, feedback transmission is less sensitive to variation in the quality of coupling between the antennas **83** and **14**.

In the external control **10**, the feedback signal F_{osc} is detected by the pickup **89** and fed to the FM demodulator **90**, which produces a voltage output V_{OUT} that is proportional to F_{osc} . V_{OUT} is fed to the filter **91** and the level detector **92** to obtain the information corresponding to the drive element signal S_A , which in turn corresponds to the pulses applied to the stepper motor coil. The microprocessor **80** counts these pulses to calculate the corresponding displacement of the tension element **32**, which is proportional to the number of pulses.

Signal V_{OUT} also is passed through the analog-to-digital converter **93** and the digital output is fed to the microprocessor **80**, where signal processing is performed to detect perturbations of the shape of the feedback signal that would indicate a blockage of the rotor of the stepper motor. The microprocessor **80** stops counting any detected motor pulses when it detects that the drive element is blocked, and outputs an indication of this status. The level detector **94** produces an output when it detects that the demodulated signal V_{OUT} indicates the presence of the reference position signal S_{RP} due to activation of the reference position switch. This output induces a reset of the position of the tension element calculated by the microprocessor **80** in the external control. In this way, a small imprecision, e.g. an offset, can be corrected.

As described above, the external control **10** transmits both energy and commands to the implantable controller circuitry in the antenna/controller pod **23**. The external control **10** also receives feedback information from the implantable controller that can be correlated to the position of the tension element **32** and the diameter of the ring **22**. As will be apparent to one of skill in the art, the external control **10** and the implantable controller are configured in a master-slave arrangement, in which the implantable controller is completely passive, awaiting both instructions and power from the external control **10**.

Pressure Measuring

Measuring the applied pressure via the present ring **22** is very important in ensuring that excessive pressure is not applied to the stomach. As such, the present invention incorporates the ability to measure the applied pressure in a reliable, effective and convenient manner. In accordance with a first embodiment, and with reference to FIGS. **106** and **107**, the applied current for the motor **66** is measured and the measured current is utilized in determining the applied pressure and ultimately as a feedback system for measuring the functional state of the gastric band **21**.

In accordance with this embodiment, the current is monitored via a closed loop feedback system **1012** integrated into the operation of the mechanical banding system **1** of the present invention. By incorporating an electrical current measurement to measure electrical current being drawn by the motor **66** of the present banding system, the performance of the banding system may be evaluated for determination of among other features, the applied pressure of the gastric band **21**. The current drawn by the motor **66** is directly related to the force being applied by the banding system. Any increase in the force applied by the gastric band **21** is proportionally linked to an increase in current being drawn by the motor **66** of the gastric band **21**. In practice, the current measured in accordance with the application of the present invention is

correlated to the static force or pressure the ring **22** applies to the stomach tissue it encircles.

In addition to its use in measuring pressure, the monitoring of the applied current may also be utilized in determining any loss of performance of the banding system due to component wear down, corrosion, etc.

Referring to FIG. **107**, the closed loop feedback system **1012** includes leads **1016** accessing the current flowing from the power source **1018** to the motor **66**. The current is measured using a current sensing circuit **1020** and the output current measurement **1022** is forward to the microcontroller **85** of the present drive element **35** for action in accordance with the goals of the present invention.

In accordance with an alternate embodiment, and with reference to FIG. **108**, measurements of the applied current are made using a Hall sensor **1024** positioned about the wire **1026** supplying the motor **66** with electrical power. When a Hall sensor **1024** is positioned above a current carrying wire **1026**, it is capable of measuring current flow through the wire **1026** and ultimately the current being drawn for operation of the motor **66** as it constricts the ring **22** to apply pressure to the stomach which the ring **22** surrounds. In accordance with the embodiment disclosed herein, the measured current is derived from a voltage measurement across a series of resistors **1028** in line with the power source **1018** for the motor **66**.

Regardless of the whether a hardwired circuit is employed or a Hall sensor is employed, the voltage is calculated by utilizing Ohms Law, that is, $V=IR$. Assuming a fixed resistance change in current, a current is directly related to the voltage drop across the resistance of the motor **66**. A typical sensing voltage might be between 50 mV and 200 mV.

In accordance with an alternate embodiment, and with reference to FIG. **109**, the tension applied by the gastric band **21**, that is the applied pressure of the gastric band **21**, is monitored by a mechanical system **1030**. In particular, the tension applied to the flexible tension element **32** is monitored utilizing a strain gauge **1032** acted on by the threading **1034** of the tension element **32**. By monitoring the force applied to the strain gauge **1032**, the operator is provided with an indication when fail-safe action is necessary.

The strain gage **1032** is preferably coupled to the nut **600** on the drive element housing **53**, for example, by means of a cantilevered beam **1036**. The interaction of the nut **600** with the threading **1034** of the tension element **32** provides highly accurate force measurements concerning the relationship between the nut **600** and the threading **1034** of the tension element **32**. By monitoring the force measurements, the pressure applied by the gastric band **21** is determined and operators of the gastric band **21** are readily able to determine when fail-safe action is necessary based upon a detection of excess tension in the gastric band **21**.

In accordance with a variation of the use of a strain gauge, the strain gauge **1032** may straddle threading on the tension element **32** so as to identify the applied force. See FIG. **110**. To identify the applied force the strain gauge output would be connected to a circuit, such as an analog to digital converter (A/D) or microcontroller **1060**, that converts the strain into an applied force. The A/D or microcontroller **1060** would provide force data to a telemetry circuit **1062** which in turn would send the data to the external reading device **1064**. The applied force could be compared to a force threshold (either dynamic or static) either by the internal circuitry **1060** or by the external reading device **1064** which in turn would provide and indication to the state of the drive mechanism. A higher force/tension in either movement direction may indicate a mechanical failure in the drive mechanism.

As with the prior embodiment, and in addition to its use in measuring tension along the gastric band **21**, the monitoring of the force encountered by the strain gauge **1032** may also be utilized in determining any loss of performance of the banding system due to component wear down, corrosion, etc. As such, the strain gauge is preferably linked to a feedback system controlling operation of the drive element **35**. It is also contemplated that in addition to a strain gage, position/proximity sensors may be employed, Hall effect sensors may be employed, contact sensors may be employed or a microswitch may be employed.

In accordance with yet a further embodiment as shown with reference to FIG. **111**, and where a fluid filled bladder **1038** is incorporated along the internal surface **1040** of the ring **22**, the pressure of the fluid within the bladder **1038** is measured to provide an indication as to the pressure being applied to the stomach via the present banding system **1**.

In accordance with this embodiment, a fluid bladder **1038** is formed along the internal surface **1040** of the mechanical gastric band **21**. The fluid bladder **1038** is formed and positioned such that it directly interfaces with tissue. In accordance with a preferred embodiment, the fluid bladder **1038** may be integrally formed with the gastric band or it may be selectively secured thereto for use in accordance with the present invention. As such, and where the fluid bladder **1038** is selectively secured to the gastric band **21**, it may be secured to the gastric band **21** prior to or during installation (implantation). A pressure sensor **1042** is linked to the fluid bladder **1038** allowing for remote monitor of the fluid pressure within the bladder **1038**.

By constructing the ring **22** in such a manner, not only is a softer tissue interface provided by the fluid bladder **1038**, but the inclusion of the fluid bladder **1038** allows for the ability to add a pressure sensor **1042** in the fluid path to measure the fluid pressure in the bladder **1038**. When the gastric band **21** is wrapped around the stomach tissue, the monitored pressure within the bladder **1038** relates to the pressure exerted on the tissue. This pressure reading is then used as a primary or secondary feedback to control the applied restriction employed in accordance with the gastric band **21** of the present invention.

In practice, and in accordance with a preferred embodiment as disclosed herein, the bladder **1038** is pre-filled with fluid and calibrated prior to implantation. While pre-implantation calibration is contemplated, it is conceived that calibration may be performed after implantation in accordance with the present invention. As such, the fluid bladder may be adjusted to ensure proper calibration. Such adjustments are achieved by connection of the fluid bladder to a filling tube via a port formed in the fluid bladder. The bladder **1038** is preferably made of silicone or another biocompatible material and is preferably filled with a non-aqueous fluid or gel, for example, silicone or fluoro-silicone oil. The pressure **1042** is preferably a piezoresistive or capacitive sensor designed for implantation in a hermetic package. The pressure **1042** is connected to a telemetry circuit **1044** allowing pressure to be read outside the body using an external reading device **1046**.

As with the previously discussed embodiments for measuring the applied pressure of the gastric band **21**, the pressure bladder **1038** may also serve as an indicator to the functional state of the mechanical gastric band **21**. Pressure should increase when the gastric band **21** is tightened and decrease when the gastric band **21** is loosened. If the mechanical system is not functioning correctly, there will be no change in pressure.

In addition to providing a fail-safe mechanism for operation of the present ring **22**, loading information garnered in

the manner discussed above, may also be used to aid the surgeon in correctly setting the band's initial degree of restriction during band implantation. That is, the loading information could also be used to help ensure that the band is initially implanted with the correct degree of restrictive adjustment. In this case an indication of tension element loading would provide surgeons (especially novice ones) with an indication of whether they've sufficiently tightened the band onto the tissue to achieve the desired constriction while also making sure that they haven't excessively tightened the band onto the tissue and/or undesirably approached the tension element's yield point.

The load measurements may also be used to prevent over-tightening the band during extended use. In particular, the loading information could also be used in an alternative manner if the band has auto-tightness adjustment capability. In this case the surgeon may or may not be present at the time the tension of the tension element is being adjusted. In this scenario, the load and/or strain measurements could be used to signal the control unit of the motor to either stop tightening the band if a pre-set load threshold is reached or actually reverse the direction of the motor to decrease tension element loading if the threshold has already been exceeded. One way to ensure that the loading threshold is never exceeded is to control the flow of current to the motor using commonly known techniques, such as current clipping, to ensure that the motor is never able to build up enough torque to over-tighten the tension element. Alternatively, an electrical fuse element could be used in conjunction with the current supplied to the motor such that the fuse would trip and either limit or release loads on the tension element if the current supplied to the motor ever exceeds an allowable threshold.

In addition to the measuring techniques discussed above, these benefits could be embodied by use of any of the load measuring techniques, such as, measuring the motor torque. In particular, the tension on the tension element may be derived from motor torque. The algorithm used in this method is explained representatively at: <http://www.dynetic.com/faq.htm>, which states, "The torque requirement for an application can be calculated, measured directly using a torque measuring device (torque watch), or measured indirectly using a DC motor. When using a motor, measure the current drawn of the motor under load, and calculate the torque using the equation below:

$$T=(I-I_{NL})\times(K_T\times N\times h)$$

Where,

I=Current

T=Torque

K_T =Torque Constant

N=Gear Ratio (Equals 1 if there is no gearbox)

h=Gearbox Efficiency (Equals 1 if there is no gearbox)

I_{NL} =No-Load Current

Please be aware this equation approximates the true load torque and does not take thermal conditions into consideration. The results are reasonably close and suitable for most purposes."

The current may be determined by measuring the current across a shunt resistor in series with the motor at the power source. The microcontroller will measure the voltage across the resistor and convert the value to current using Ohm's Law ($I=V/R$ where I=current, V=voltage and R=Resistance across the shunt resistor) in order to determine torque.

This value may be converted to tension since the tension element is a screw thread or cable.

In general, a representative conversion equation for torque to axial load (cable tension) is:

$$T=DF$$

Where,

T=Torque required

F=Desired cable tension

D=cable thread nominal diameter (major dia)

Since it is not generally recommended that induced stress exceed a safe fraction of the yield strength of the tension element, it may be desirable to introduce a fractional coefficient c (less than or equal to 1) in the equation:

$$T=cDF$$

Expressed in terms of cable tension:

$$F=T/cD$$

Since this relationship is linear, however, any correlations such as those discussed below to band adjustments may be made using torque or tension. Thus, current, torque or cable tension may all be used as an adjustment parameter, much the same as the pressure measurements as described in U.S. Patent Application Publication No. 2006/0211913, entitled "NON-INVASIVE PRESSURE MEASUREMENT IN A FLUID ADJUSTABLE RESTRICTIVE DEVICE", which is incorporated herein by reference.

As discussed above, the tension upon the tension element may be measured by monitoring component strain. The tension may be measured directly via a strain gauge. The strain gauge may be positioned in a number of locations such that the tension would cause a strain, i.e.,

on the tension element **32** itself, measuring stretch of the tension element **32** (See FIG. **110**)

between the rear hub and the nut **60** (see FIG. **109**);

between the tension element **32** and an axially grounded portion of the hub.

The strain read by the strain gauge may be translated to tension element **32** tension by the association:

$$\sigma=E\epsilon$$

Where,

σ =the cable stress= F_t/A

F_t =the cable tension

A=the cross sectional area of the cable

E=the elastic modulus of the material

ϵ =the strain in the cable

So,

$$F_t=E\epsilon A$$

In accordance with yet another embodiment, the strain gauge location could be used as a compressive force gauge if the nut is free to translate slightly with the thread. The gauge would be positioned under the nut on the side opposite the direction of translation of the threaded shaft and the nut would impose a compressive force on to the gauge when the band is adjusted. In a manner similar to the tension measured above the force could also be measured with compression as well. Thin film load cells are commercially available and can be found in U.S. Pat. No. 6,272,936. This circuit can be made to fit a very tiny space in-between the nut **60** and the hosing plate.

In accordance with yet another embodiment as shown with reference to FIG. **112**, the axial loads on the tension element **32** may be measured. In accordance with such an embodiment, the tension force between the end of the spring element (that is the tension member **32**), and the threaded shaft at the free end **34** of the tension element **32** is measured. A small

transducer 1032 is attached that measures the axial load seen by the threaded shaft as the gastric band 21 is adjusted. This could also be employed at various locations along the tension element 32, such as those indicated by the red circles.

Operational Modes

Referring to FIG. 103, some of the safety features of the banding system of the present invention are described. As discussed above with respect to FIG. 105, both power and control signals are provided to the implantable controller from the external control 10. Because power is delivered to the implantable controller via magnetic induction, the amount of energy delivered to the controller depends on the quality of the coupling between the external antenna 14 and the antenna circuitry contained within the antenna/controller pod 23.

The quality of the coupling may be evaluated by analyzing the level of the feedback signal received by the external control 10, and a metric corresponding to this parameter may be displayed on the signal strength indicator 17, which includes 6 LEDs (corresponding to six levels of coupling). If the coupling between the antennas 14, 83 is insufficient, the motor 66 of the drive element 35 may not work properly, resulting in an inaccurate adjustment of the gastric band 21.

Accordingly, in a standard mode of operation, adjustment may be made only if the coupling quality is strong enough, as indicated by having at least LED 5 or LED 6 in FIG. 103 illuminated. If on the other hand, poor coupling exists (e.g., one of the first four LEDs are illuminated) it is still possible to perform some adjustment of the gastric band 21, although the adjustment may be inaccurate.

The design of the external control 10, in combination with the patient microchip card 16 (see FIG. 1), also ensures a high degree of efficacy and safety. First, as contemplated for use with the gastric band 21 of the present invention, the external control 10 is intended primarily for use by a physician in an office or hospital setting, and not by the patient alone. Of course, in alternative embodiments, such as to treat urinary or fecal incontinence, it would be essential to provide an external control 10 for use by the patient. The simplicity of the design of the external control 10 and ease of use would provide no impediment to use by the patient for such embodiments.

As discussed with respect to FIG. 1, patient microchip card 16 stores, among other data, a serial number identifying a corresponding gastric band 21 and the diameter of the ring 22 upon completion of the previous adjustment. When the external control 10 first transmits energy to the implantable controller of the gastric band 21, the gastric band 21 identifies itself to the external control 10. In the standard mode of operation, the serial number stored on the patient microchip card 16 must match that received from the gastric band 21, otherwise no adjustment is permitted.

As a fail-safe, however, the physician still may adjust the gastric band 21 even if the patient has lost or misplaced his microchip card 16. In this case, the external control 10 may be set in a "no card mode". In this mode, the information displayed on the display screen 13 of the external control 10 corresponds only to the relative variation of the gastric band 21 during that adjustment session, and is no longer indicative of absolute diameter. When the physician activates this mode, an emergency bit is set in the memory of the implantable controller to indicate the "no card mode". In subsequent adjustment sessions, the implantable controller will signal that the gastric band 21 was adjusted in the "no card mode" and all further adjustments will be reported on a relative basis. If the patient again locates the microchip card 16, the emergency bit may be cleared by fully opening the gastric band 21

and thus reaching the reference contact, which re-initializes the position. Subsequent adjustments will again be managed in the standard mode of operation.

During adjustment of the ring 22, a physician places the external antenna 14 in a face-to-face position on the skin of the patient relative to the antenna/controller pod 23 of the ring 22, and to receive feedback information from which the constricted diameter of the ring 22 may be computed. In accordance with the principles of the present invention, it is possible to vary the diameter of the ring 22 without having to undertake invasive surgical intervention, and this variation may be carried out at will, because multiple control cycles may be carried out at regular or irregular intervals, solely under the control of the treating physician.

The banding system of the present invention is expected to be particularly reliable, relative to previously-known hydraulic bands that can be adjusted by the patient, because only the physician typically will have access to the external control box needed to adjust the ring. For a ring embodiment intended for treatment of morbid obesity, the patient therefore does not have free access to any means to adjust the diameter of the ring.

Moreover, because the gastric band of the present invention provides a precise readout of the current diameter of the ring in the standard mode of operation, it may not be necessary for the patient to ingest a radiographic material (e.g., barium dye) to permit radiographic visualization of the ring to confirm the adjusted size. The process of adjusting the band accordingly may be carried out in a doctor's office, without the expense associated with radiographic confirmation of such adjustments. In addition, the self-blocking configuration of the tension element and nut, in combination with the mechanical nature of the gastric band, overcome problems associated with previously-known hydraulically actuated gastric band systems.

Methods of Implantation and Removal

Referring now to FIG. 104, the gastric band 21 of the present invention is shown implanted in a patient. The ring 22 is disposed encircling the upper portion of the patient's stomach S while the antenna/controller pod 23 is disposed adjacent to the patient's sternum ST. The antenna/controller pod 23 is located in this position beneath the patient's skin SK so that it is easily accessible in the patient's chest area to facilitate coupling of the antenna/controller pod 23 to the external antenna 14 of the external control 10 (see FIG. 1).

Other Features

In addition to the features discussed above, the present invention provides a mechanism for protecting the implanted electronics from electromagnetic interference (for example, from MRI). In particular, the electronics of the device are encased in a titanium case 1202 (see FIG. 72) and the antenna 1283 is moved external to the titanium case 1202. In this way, the electronics may be implanted deeper into the body cavity, leaving only a thin antenna near the surface of the skin.

In addition, time limit warning on the packaging of the device may be avoided

where the gastric band is prefilled with fluid or gel, air would not permeate the silicone. The fluid could be incorporated during manufacturing or injected once the device is opened in the operating room. This would also improve the tissue interface of the gastric band by making it softer.

if the gastric band were shipped in fluid or instructed to place the device in a saline bath when opened, it could stay in place indefinitely.

If the silicone is coated with parylene, titanium or similar compositions to reduce permeation rates thereby increasing the open air time.

If the balloon is left unsealed. Since the band is mechanical and not hydraulic, the balloon has no functional need to be sealed.

As stated in the System Overview portion of the present application, the telemetrically-powered and controlled ring system of the present invention has numerous applications apart from gastric banding for the treatment of morbid obesity. For example, the ring system of the present invention may advantageously be used for the treatment of fecal incontinence, ileostomy, coleostomy, gastro-esophageal reflux disease, urinary incontinence and isolated-organ perfusion.

For treatment of fecal incontinence, the ring may be used with little or no modifications. In addition, because the ring adjustment procedure will be performed by the patient on at least a daily basis, a portable user-friendly external control may be used. In addition, because the ring will regularly be transitioned between the closed and fully opened position, the patient microchip card is unneeded. Instead, the fully closed position may be stored in the memory of the implantable controller, and read by the external remote at each use (subject to periodic change by the physician).

A similarly modified device could be used by patients who have undergone ileostomy or coleostomy, or disposed surrounding the esophageal junction, to treat gastro-esophageal reflux disease.

For treatment of urinary incontinence, the ring may be further modified to minimize the volume of the ring surrounding the urethra by moving the drive element motor to a location elsewhere in the lower abdomen or pelvis, and coupling the drive element to the motor via a transmission cable.

The present invention also may be beneficially employed to perform isolated-organ perfusion. The treatment of certain cancers requires exposure to levels of chemotherapy agents that are too high for systemic circulation. It has been suggested that one solution to this problem is perform an open surgery procedure in which blood flow to the cancerous organ is stopped and quiescent blood replaced by circulation from an external source containing a desired dose of drug. Individual or multiple rings of the present invention may be used as valves to isolate the cancerous organ and permit perfusion of the organ with high doses of drugs. Such procedures could thus be performed on a repetitive basis without surgery, thereby reducing the trauma and the risk to the patient while improving patient outcomes.

Although particular embodiments of the present invention have been described above in detail, it will be understood that this description is merely for purposes of illustration. Further variations will be apparent to one skilled in the art in light of this disclosure and are intended to fall within the scope of the appended claims.

As discussed above, it is possible to make highly accurate load measurements regarding the load applied by the ring in accordance with the present invention. This information may be used to dynamically adjust the band's degree of restriction to optimize weight loss. This may prove helpful to surgeons in making a correlation between tension on the tension element and how tightly the band is tightened on tissue. Much the same as the pressure measurements as described in U.S. Patent Application Publication No. 2006/0211913, entitled "NON-INVASIVE PRESSURE MEASUREMENT IN A FLUID ADJUSTABLE RESTRICTIVE DEVICE", which is incorporated herein by reference; that is, the manner in which pressure magnitude and pulse counting of peristaltic waves is used as a target against which to adjust, the load or strain

measurements may be used in a similar fashion as a measure of peristaltic pressure. Such systems are disclosed in U.S. Patent Application Publication No. 2006/0189888, entitled "DEVICE FOR NON-INVASIVE MEASUREMENT OF FLUID PRESSURE IN AN ADJUSTABLE RESTRICTION DEVICE", and U.S. Patent Application Publication No. 2009/0187202, entitled "OPTIMIZING THE OPERATION OF A RESTRICTION SYSTEM", which are also incorporated by reference. Pressure waves from esophageal peristalsis will cause tension changes in the cable which may be read and correlated to proper or improper adjustment. Pulses may be counted from this same means, along with pulse width, duration, etc. Much of the information that can be gained will be able to be derived from the present mechanism.

Multiple methods of storing the measured loads on the band are disclosed, which include but are not limited to:

Storing motor torque;

Storing mechanical strain;

Storing compressive and axial loads.

With regard to storing motor torque, the component torque, as described above, may also be stored for later analysis by a torque measuring device (torque watch). Simpler models would just record and store peak values, which may be sufficient for this application. Alternatively, a more complex model would allow for storage of continuously obtained torque information. Due to storage capacity, it is likely that the data would need to be recorded in set increments and be downloaded periodically. Alternately, if the torque was measured indirectly using a DC motor as described above, a multimeter may be used to record and store peak values and/or continuously obtain information which could then be converted to torque via the above equations.

As to storing mechanical strain, the component strain, as described above, may also be stored for later analysis by a strain gauge. Simpler models would just record and store peak values, which may be sufficient for this application. Alternatively, a more complex model would allow for storage of continuously obtained strain information. Due to storage capacity, it is likely that the data would need to be recorded in set increments and be downloaded periodically.

Compressive and axial loads may also be stored, as described above. This information is stored for later analysis by a strain gauge. A basic force gauge may be used to store compressive and axial loads. Simpler models would just record and store peak values, which may be sufficient for this application. Alternatively, a more complex model would allow for storage of continuously obtained torque information.

Stored information to interested parties (i.e., Surgeon, Primary Care Physician (PCP), Patient, etc.) may be relayed to other parties for use at remote locations. With regard to the relay of information to the surgeon/PCP, a surgeon or primary care physician may be interested in obtaining and using the information gathered to make determinations about the restriction provided by the band and/or complications arising from the tightness of the band. As a result, it is desirable that the information measured and stored as described above is also accessible by the surgeon or PCP. One mechanism for achieving this would be to use an external data logger which would be worn by the patient. Information stored in this device could be downloaded by the surgeon or PCP by means of a USB port. For example, see U.S. Patent Application Publication No. 2006/0199997, entitled "MONITORING OF A FOOD INTAKE RESTRICTION DEVICE" and U.S. Patent Application Publication No. 2008/0249806, entitled

“DATA ANALYSIS FOR AN IMPLANTABLE RESTRICTION DEVICE AND A DATA LOGGER”, which are hereby incorporated by reference.

As to the relay of information to the patient, patients would be interested in obtaining some information about the status of the restriction in their band for various reasons. For example, one reason would be to indicate that there may be a problem with their implant and direct them to visit their surgeon. Since it would probably not be necessary or useful for them to receive numerical information about the torque, strain or load present in their band, a different type of relaying method would be important. One option would be an audible noise (i.e., alarm) which would indicate to them if there was a potential issue with their implant. Alternatively, if they were wearing an external data logger as described above, a visual light (i.e., flashing red or green) could indicate the status of their implant.

While the preferred embodiments have been shown and described, it will be understood that there is no intent to limit the invention by such disclosure, but rather, is intended to cover all modifications and alternate constructions falling within the spirit and scope of the invention.

The invention claimed is:

1. Apparatus for regulating the function of a patient’s organ or duct, comprising:

an elongated member having a first end and a second end; a fastener disposed on the first end of the elongated member, the fastener configured to engage the second end of the elongated member so that the elongated member forms a loop around the organ or duct;

a tension element disposed for movement within the elongated member;

a drive element associated with and engaging the tension element for causing the tension element to control the tension applied by the elongated member against a patient’s body organ or duct; and

a release mechanism associated with the tension element and the drive element for selectively releasing the tension element from engagement with the drive element; and wherein the tension element includes a free end and a fixed end, the fixed end is secured to the drive element via the release mechanism allowing the fixed end of the tension element to be selectively released from the drive element for release of tension being applied by the elongated member, the release mechanism including a jaw mechanism that selectively engages the fixed end of the tension element.

2. The apparatus according to claim 1, wherein the release mechanism is associated with a fluid filling mechanism applying fluid to a bladder formed in the elongated member upon actuation of the release mechanism.

3. The apparatus according to claim 1, wherein the release mechanism is a fracture mechanism securing the fixed end of the tension element in position.

4. Apparatus for regulating the functioning of a patient’s organ or duct, comprising:

an elongated member having a first end and a second end; a fastener disposed on the first end of the elongated member, the fastener configured to engage the second end of the elongated member so that the elongated member forms a loop around the organ or duct;

a tension element disposed for movement within the elongated member;

a drive element associated with and engaging the tension element for causing the tension element to control the tension applied by the elongated member against a patient’s body organ or duct; and

a release mechanism associated with the tension element and the drive element for selectively releasing the tension element from engagement with the drive element; wherein the tension element includes a free end and a fixed end, the fixed end is secured to the drive element via the release mechanism allowing the fixed end of the tension element to be selectively released from the drive element for release of tension being applied by the elongated member, the release mechanism including a jaw mechanism that selectively engages the fixed end of the tension element; and

wherein the jaw mechanism includes a fixed jaw member and a movable jaw member, and a jaw drive element is positioned between the fixed jaw member and the movable jaw member.

5. The apparatus according to claim 4, wherein the jaw drive element is a balloon selectively expanded for engagement with the fixed jaw member and the movable jaw member in a manner selectively moving the movable jaw member to its release orientation relative to the fixed jaw member.

6. The apparatus according to claim 4, wherein the jaw drive element is a shape memory alloy spring positioned between the fixed jaw member and the movable jaw member.

7. The apparatus according to claim 6, wherein the shape memory alloy spring is linked to a source of electricity, and upon application of a voltage and/or current across the shape memory alloy spring, the shape memory alloy spring will change shape and thereby force the fixed jaw member and movable jaw member apart in a manner moving the jaw mechanism to its release orientation.

8. Apparatus for regulating the functioning of a patient’s organ or duct, comprising:

an elongated member having a first end and a second end; a fastener disposed on the first end of the elongated member, the fastener configured to engage the second end of the elongated member so that the elongated member forms a loop around the organ or duct;

a tension element disposed for movement within the elongated member;

a drive element associated with and engaging the tension element for causing the tension element to control the tension applied by the elongated member against a patient’s body organ or duct; and

a release mechanism associated with the tension element and the drive element for selectively releasing the tension element from engagement with the drive element; wherein the tension element includes a free end and a fixed end, the fixed end is secured to the drive element via the release mechanism allowing the fixed end of the tension element to be selectively released from the drive element for release of tension being applied by the elongated member, the release mechanism including a jaw mechanism that selectively engages the fixed end of the tension element; and

wherein the jaw mechanism includes a first movable jaw member and a second movable jaw member, the first movable jaw member and the second movable jaw member being pivotally connected with a jaw drive element positioned between the first movable jaw member and the second movable jaw member.

9. The apparatus according to claim 8, wherein the jaw drive element is a balloon selectively expanded for engagement with the first movable jaw member and the second movable jaw member in a manner selectively moving the first movable jaw member and the second movable jaw member to their release orientation.

47

10. Apparatus for regulating the functioning of a patient's organ or duct, comprising:

an elongated member having a first end and a second end;
 a fastener disposed on the first end of the elongated member, the fastener configured to engage the second end of the elongated member so that the elongated member forms a loop around the organ or duct;
 a tension element disposed for movement within the elongated member;
 a drive element associated with and engaging the tension element for causing the tension element to control the tension applied by the elongated member against a patient's body organ or duct; and
 a release mechanism associated with the tension element and the drive element for selectively releasing the tension element from engagement with the drive element; wherein the tension element includes a free end and a fixed end, the fixed end is secured to the drive element via the release mechanism allowing the fixed end of the tension element to be selectively released from the drive element for release of tension being applied by the elongated member, the release mechanism includes a jaw mechanism that selectively engages the fixed end of the tension element; and

wherein the release mechanism is a fracture mechanism securing the fixed end of the tension element in position and the fixed end of the tension element is secured to an elongated coupling element extending within a shape memory alloy tube, and wherein upon heating or cooling of the shape memory alloy tube, the tube will change shape in a manner fracturing the elongated coupling element and permitting release of the fixed end of the tension element.

11. The apparatus according to claim **10**, wherein a heating coil is positioned about the shape memory alloy tube for selective heating of the shape member alloy tube.

12. The apparatus according to claim **10**, wherein a cooling coil is positioned about the shape memory alloy tube for selective cooling of the shape member alloy tube.

13. Apparatus for regulating the functioning of a patient's organ or duct, comprising:

an elongated member having a first end and a second end;
 a fastener disposed on the first end of the elongated member, the fastener configured to engage the second end of the elongated member so that the elongated member forms a loop around the organ or duct;
 a tension element disposed for movement within the elongated member;
 a drive element associated with and engaging the tension element for causing the tension element to control the

48

tension applied by the elongated member against a patient's body organ or duct; and

a release mechanism associated with the tension element and the drive element for selectively releasing the tension element from engagement with the drive element; wherein the tension element includes a free end and a fixed end, the fixed end is secured to the drive element via the release mechanism allowing the fixed end of the tension element to be selectively released from the drive element for release of tension being applied by the elongated member, the release mechanism including a jaw mechanism that selectively engages the fixed end of the tension element; and

wherein the release mechanism is a fracture mechanism securing the fixed end of the tension element in position and the release mechanism is associated with a fluid source in conjunction with a fluid filling mechanism applying fluid to a bladder formed in the elongated member upon actuation of the release mechanism.

14. Apparatus for regulating the functioning of a patient's organ or duct, comprising:

an elongated member having a first end and a second end;
 a fastener disposed on the first end of the elongated member, the fastener configured to engage the second end of the elongated member so that the elongated member forms a loop around the organ or duct;
 a tension element disposed for movement within the elongated member;
 a drive element associated with and engaging the tension element for causing the tension element to control the tension applied by the elongated member against a patient's body organ or duct; and

a release mechanism associated with the tension element and the drive element for selectively releasing the tension element from engagement with the drive element; wherein the tension element includes a free end and a fixed end, the fixed end is secured to the drive element via the release mechanism allowing the fixed end of the tension element to be selectively released from the drive element for release of tension being applied by the elongated member, the release mechanism including a jaw mechanism that selectively engages the fixed end of the tension element; and

wherein the release mechanism is a fracture mechanism securing the fixed end of the tension element in position and the release mechanism is associated with a fluid source that when actuated releases fluid from a bladder formed in the elongated member upon actuation of the release mechanism.

* * * * *