

US008661688B2

(12) **United States Patent**  
**Shigeta et al.**

(10) **Patent No.:** **US 8,661,688 B2**  
(45) **Date of Patent:** **Mar. 4, 2014**

(54) **ELECTRIC SHAVER**  
(75) Inventors: **Hiroshi Shigeta**, Fujiidera (JP);  
**Masanobu Yamasaki**, Hikone (JP); **Shin**  
**Hosokawa**, Hikone (JP); **Takeshi Shiba**,  
Hikone (JP); **Jyuzaemon Iwasaki**,  
Nagahama (JP)  
(73) Assignee: **Panasonic Corporation**, Osaka (JP)  
(\*) Notice: Subject to any disclaimer, the term of this  
patent is extended or adjusted under 35  
U.S.C. 154(b) by 500 days.

4,922,608	A *	5/1990	Pahl	30/43.91
4,930,217	A	6/1990	Wolf et al.	
5,235,749	A *	8/1993	Hildebrand et al.	30/43.92
5,313,704	A *	5/1994	Atsumi et al.	30/43.6
5,524,345	A *	6/1996	Eichhorn	30/34.1
5,701,673	A *	12/1997	Ullmann et al.	30/34.1
D394,329	S *	5/1998	Ullmann	D28/49
6,481,103	B2 *	11/2002	Van Hout et al.	30/34.1
6,502,312	B2 *	1/2003	Beutel et al.	30/34.1
6,789,322	B2 *	9/2004	Iwashita et al.	30/43.92
6,931,731	B2 *	8/2005	Izumi et al.	30/34.1
7,143,515	B2 *	12/2006	Izumi et al.	30/34.1
7,461,456	B2 *	12/2008	Tsushio et al.	30/43.92
7,707,725	B2 *	5/2010	Eichhorn et al.	30/34.1
7,832,104	B2 *	11/2010	Yamasaki et al.	30/34.1
7,937,837	B2 *	5/2011	Psimadas et al.	30/34.1
8,381,405	B2 *	2/2013	Shigeta et al.	30/34.1

(Continued)

(21) Appl. No.: **12/649,433**  
(22) Filed: **Dec. 30, 2009**

(65) **Prior Publication Data**  
US 2010/0175259 A1 Jul. 15, 2010

**FOREIGN PATENT DOCUMENTS**

CN	101797758	A *	8/2010
DE	102005044175		3/2007

(Continued)

(30) **Foreign Application Priority Data**  
Jan. 15, 2009 (JP) ..... 2009-006374

**OTHER PUBLICATIONS**

Japan Office action, dated Sep. 20, 2011 along with an English translation thereof.

(Continued)

(51) **Int. Cl.**  
**B26B 19/00** (2006.01)  
(52) **U.S. Cl.**  
USPC ..... **30/34.1**; 30/43; 30/45  
(58) **Field of Classification Search**  
USPC ..... 30/34.1, 43, 41.9, 43.3–43.92, 42, 44,  
30/45  
See application file for complete search history.

*Primary Examiner* — Jason Daniel Prone  
(74) *Attorney, Agent, or Firm* — Greenblum & Bernstein P.L.C.

(56) **References Cited**  
U.S. PATENT DOCUMENTS

3,797,109	A *	3/1974	Yamada et al.	30/43.6
4,114,264	A *	9/1978	Buchholz	30/34.1
4,426,776	A *	1/1984	Kakumoto et al.	30/34.1
4,505,036	A *	3/1985	Ochiai et al.	30/34.1
4,649,642	A *	3/1987	Nagasaki et al.	30/34.1

(57) **ABSTRACT**  
An electric shaver including: a gripper portion to be held by the user's hand; and a head portion configured to hold a shaving-blade unit and supported to be swingable in predetermined directions with respect to the gripper portion, wherein the head portion is provided with an edge-trimmer-blade unit.

**4 Claims, 16 Drawing Sheets**

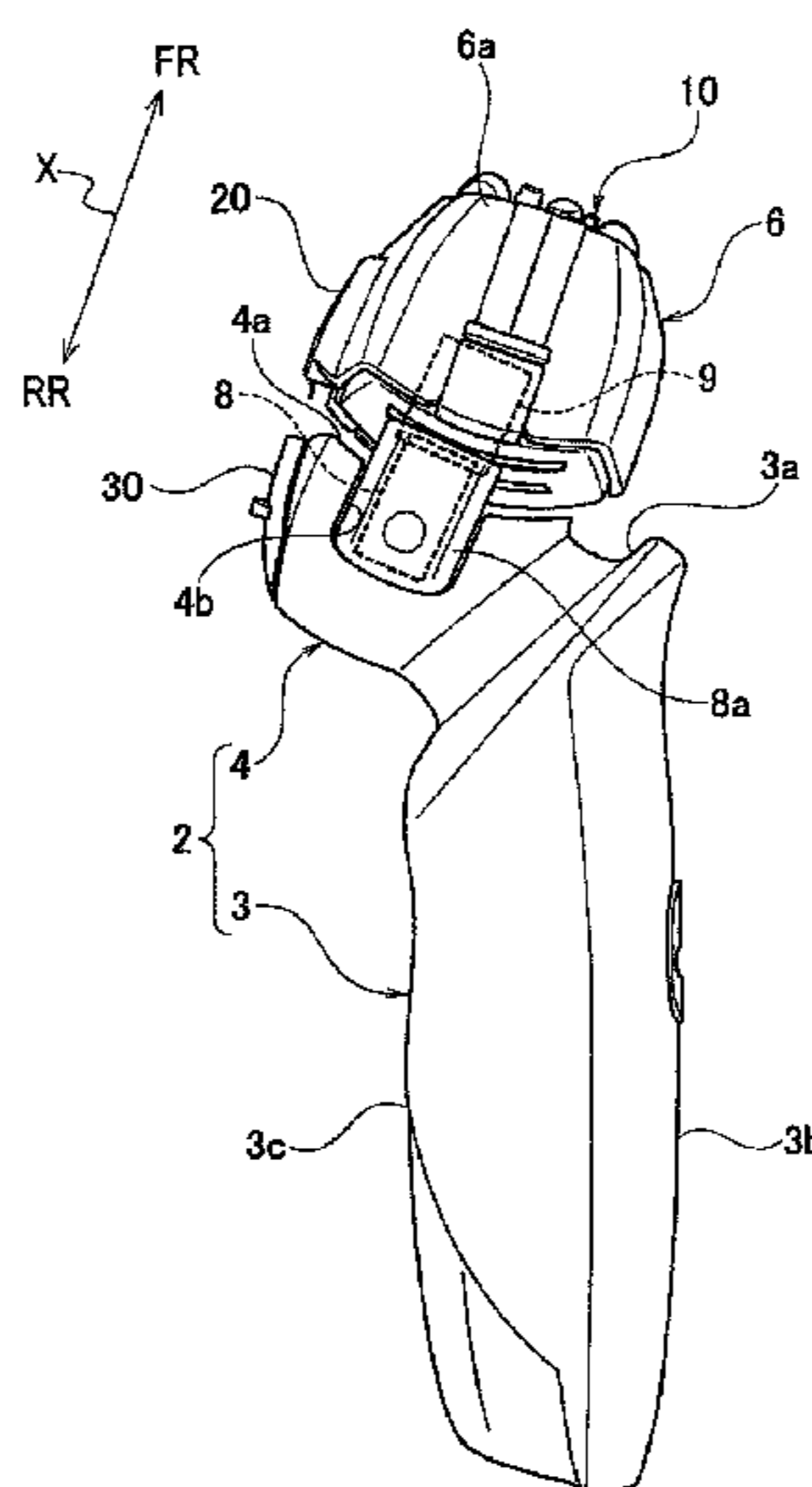

(56)

**References Cited**

U.S. PATENT DOCUMENTS

2001/0003228	A1 *	6/2001	Van Hout et al. ....	30/34.1
2003/0221319	A1 *	12/2003	Iwashita et al. ....	30/43.92
2004/0010919	A1	1/2004	Shiba et al.	
2004/0163257	A1 *	8/2004	Morisugi et al. ....	30/34.1
2004/0231160	A1 *	11/2004	Shiba et al. ....	30/43.92
2005/0028371	A1	2/2005	Kakimoto	
2006/0150421	A1	7/2006	Sato et al.	
2007/0022607	A1	2/2007	Takeuchi et al.	
2008/0040927	A1 *	2/2008	Lau .....	30/34.1
2008/0313909	A1	12/2008	Haczek et al.	
2009/0217531	A1 *	9/2009	Muraguchi .....	30/45
2009/0241343	A1	10/2009	Yamasaki et al.	
2010/0175260	A1 *	7/2010	Shigeta et al. ....	30/34.1
2010/0175262	A1 *	7/2010	Shigeta et al. ....	30/43
2010/0175263	A1 *	7/2010	Shimizu et al. ....	30/43.92
2010/0175264	A1 *	7/2010	Shimizu et al. ....	30/45
2011/0131812	A1 *	6/2011	Erndt et al. ....	30/34.1

FOREIGN PATENT DOCUMENTS

EP	0297300	1/1989
EP	1504859	2/2005

EP	2208585	A1 *	7/2010
EP	2208586	A1 *	7/2010
EP	2208587	A1 *	7/2010
EP	2208588	A1 *	7/2010
EP	2208589	A1 *	7/2010
JP	57-037472		3/1982
JP	64-022279		1/1989
JP	64-056089		3/1989
JP	2001-232074		8/2001
JP	2002-315978		10/2002
JP	2004-049864		2/2004
JP	2005-052466		3/2005
JP	2005-304793		11/2005
JP	5127730	B2 *	1/2013
RU	2432253	C2 *	10/2011
WO	WO 2010082419	A1 *	7/2010

OTHER PUBLICATIONS

China Office action, dated Mar. 30, 2011 along with an English translation thereof.

E.P.O. Office action, mail date is Jul. 29, 2011.

\* cited by examiner



FIG. 2

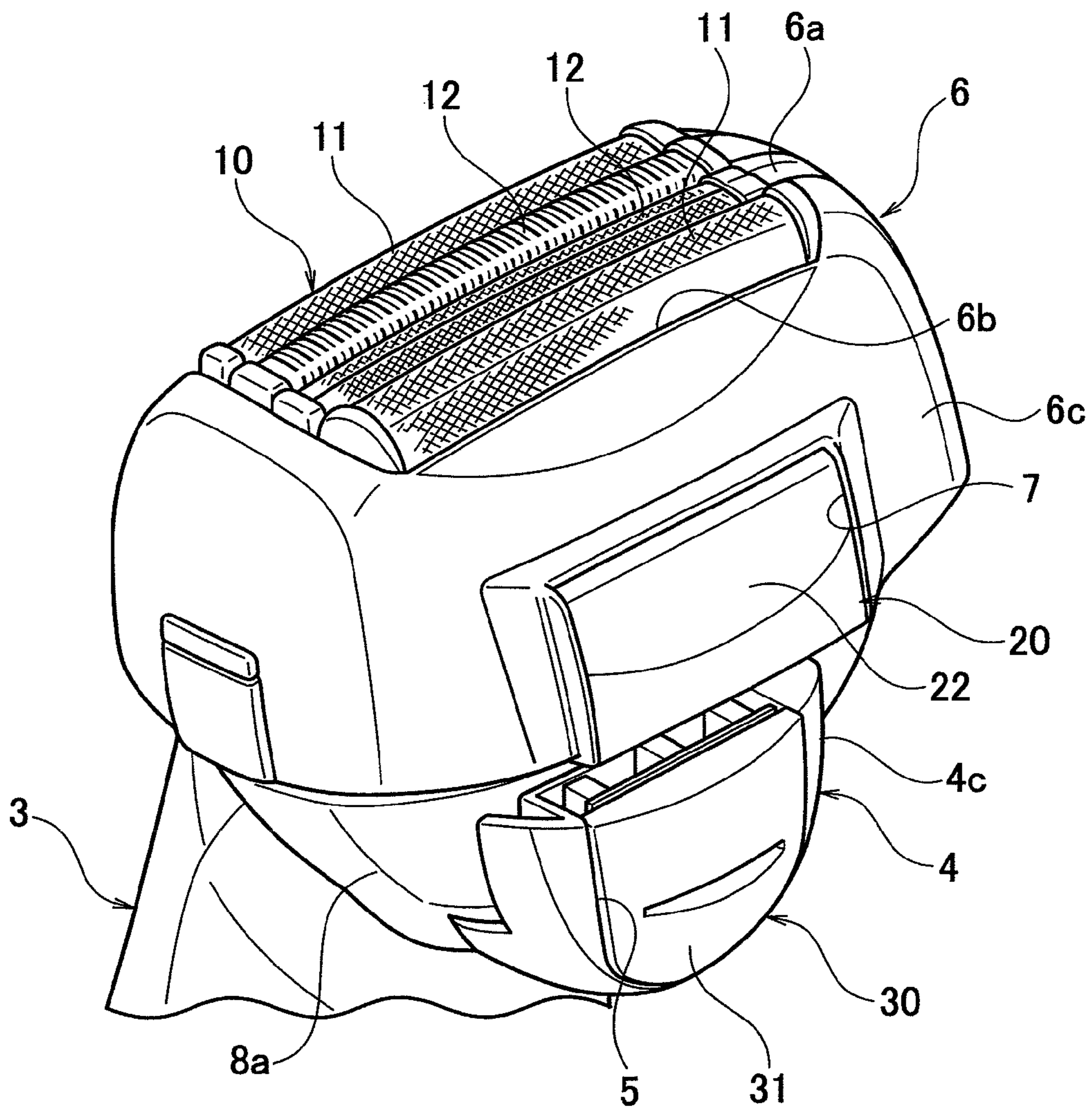

FIG. 3

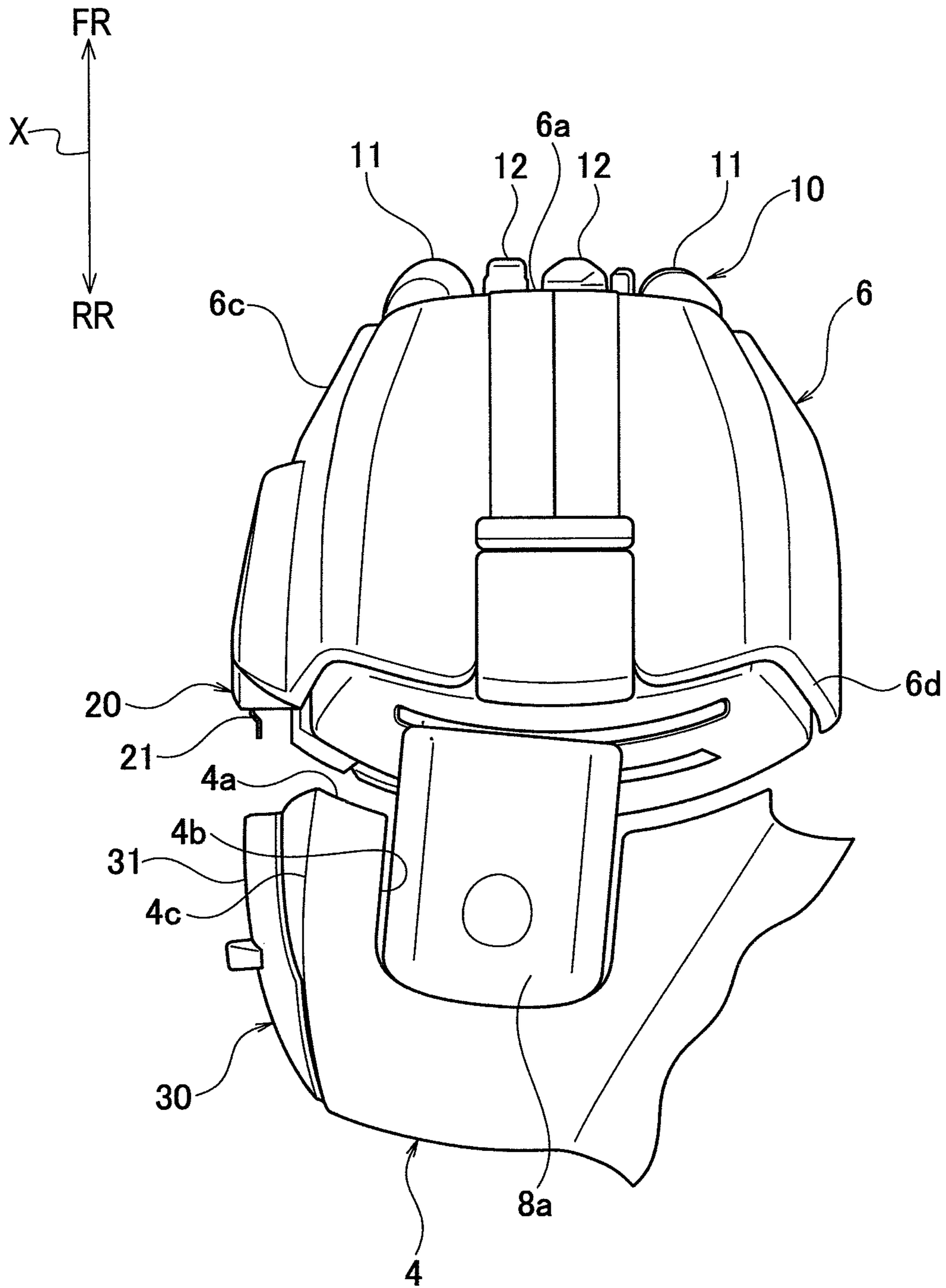

FIG. 4

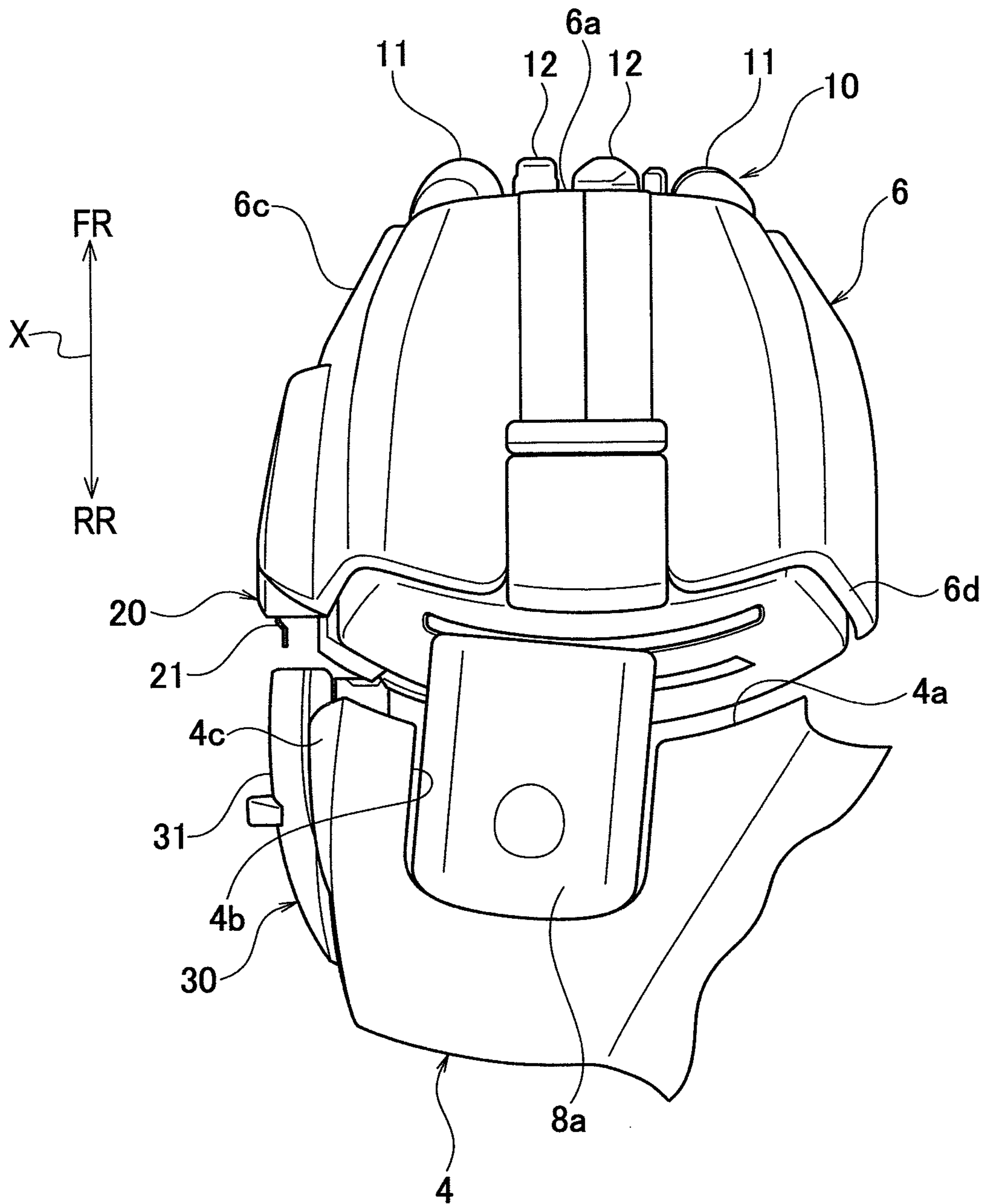

FIG. 5

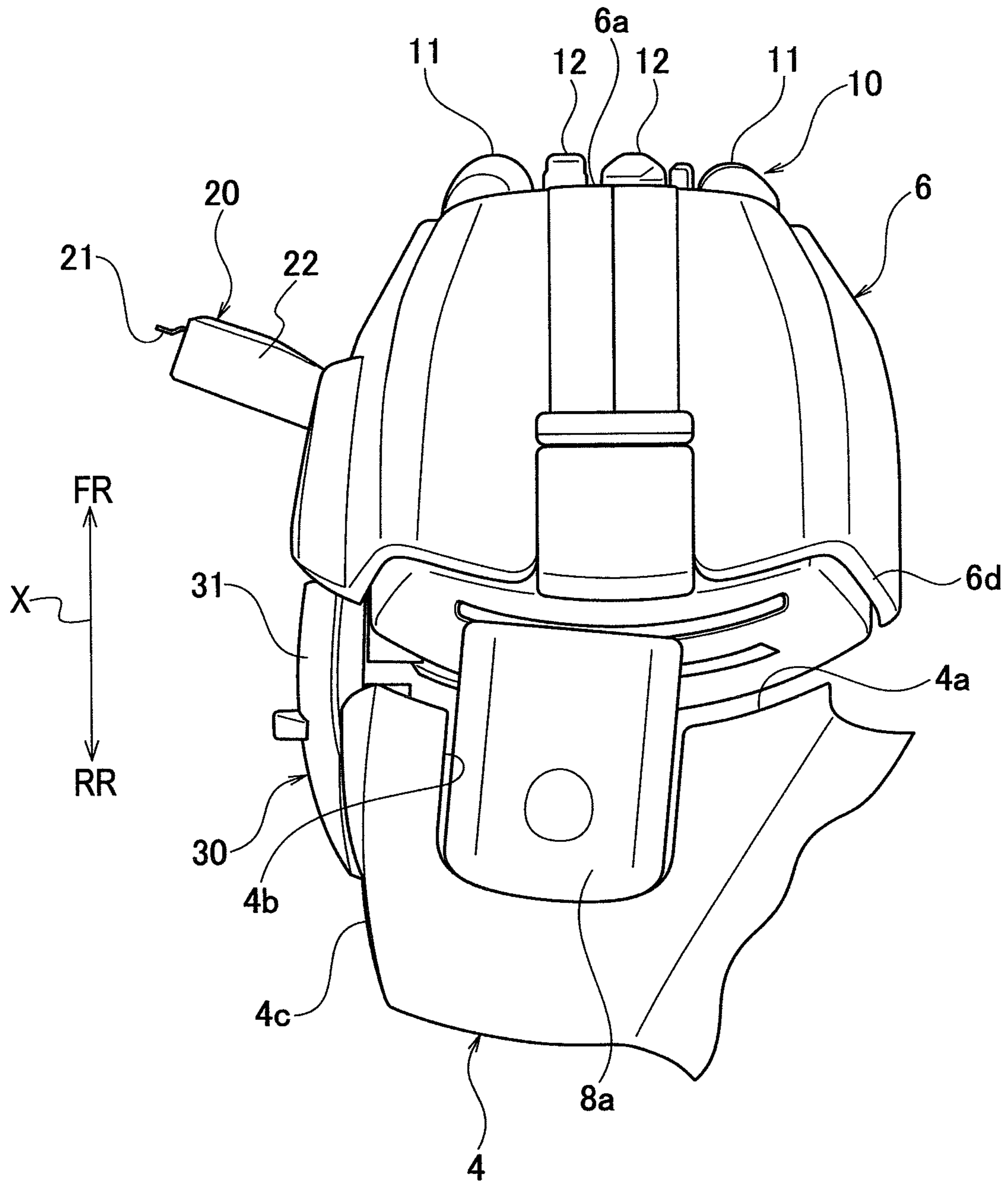

FIG. 6

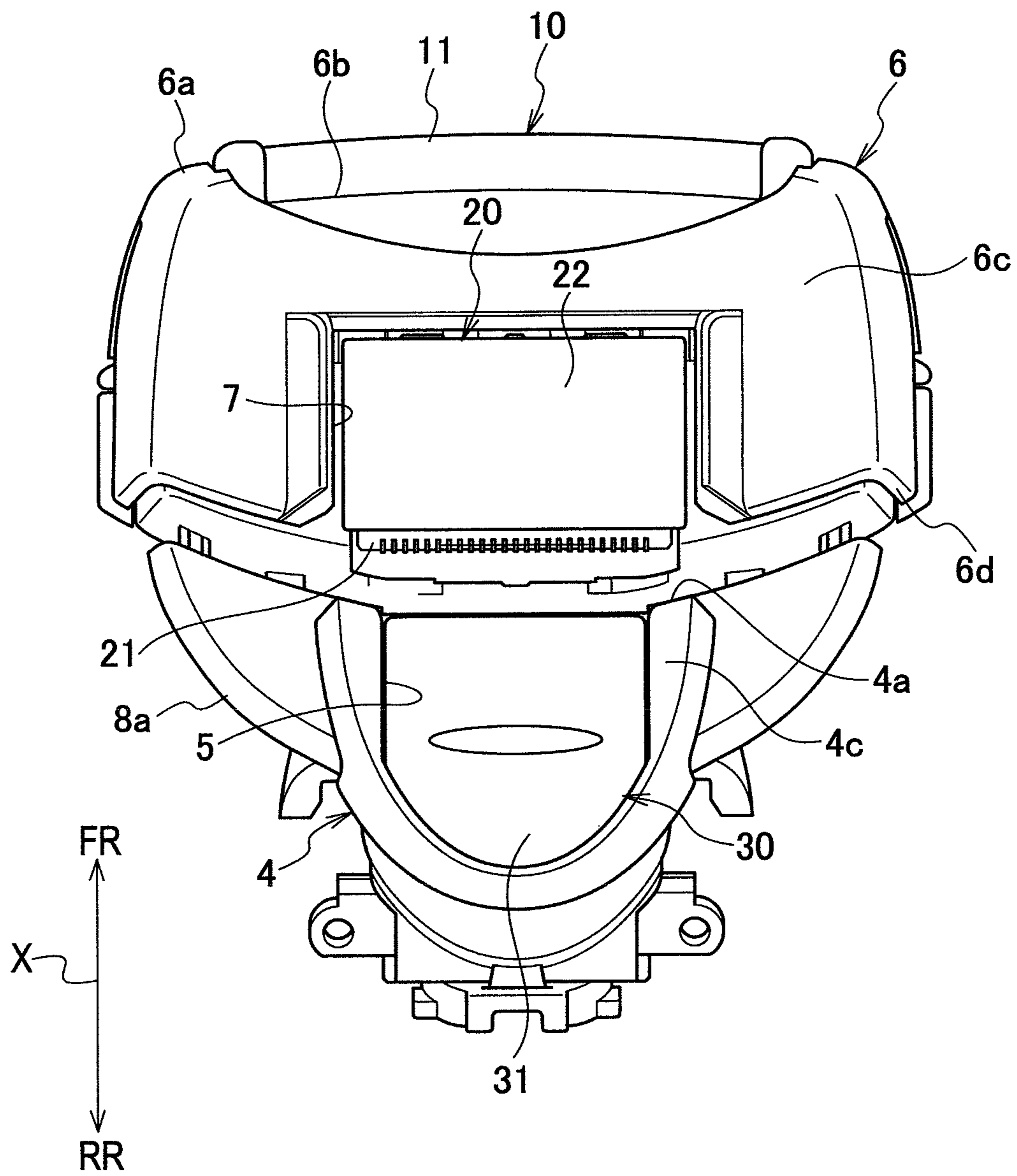



FIG. 7

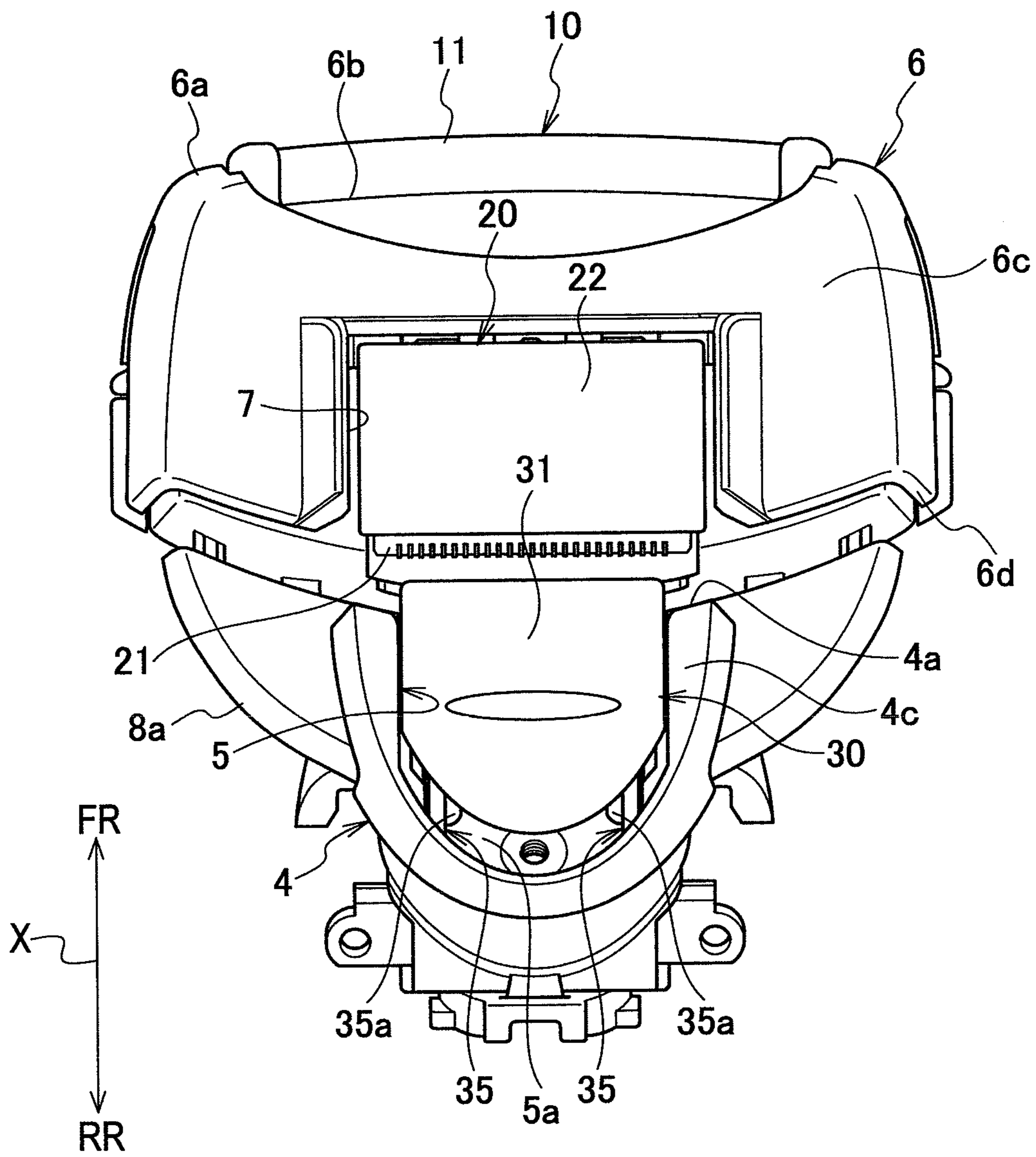

FIG. 8

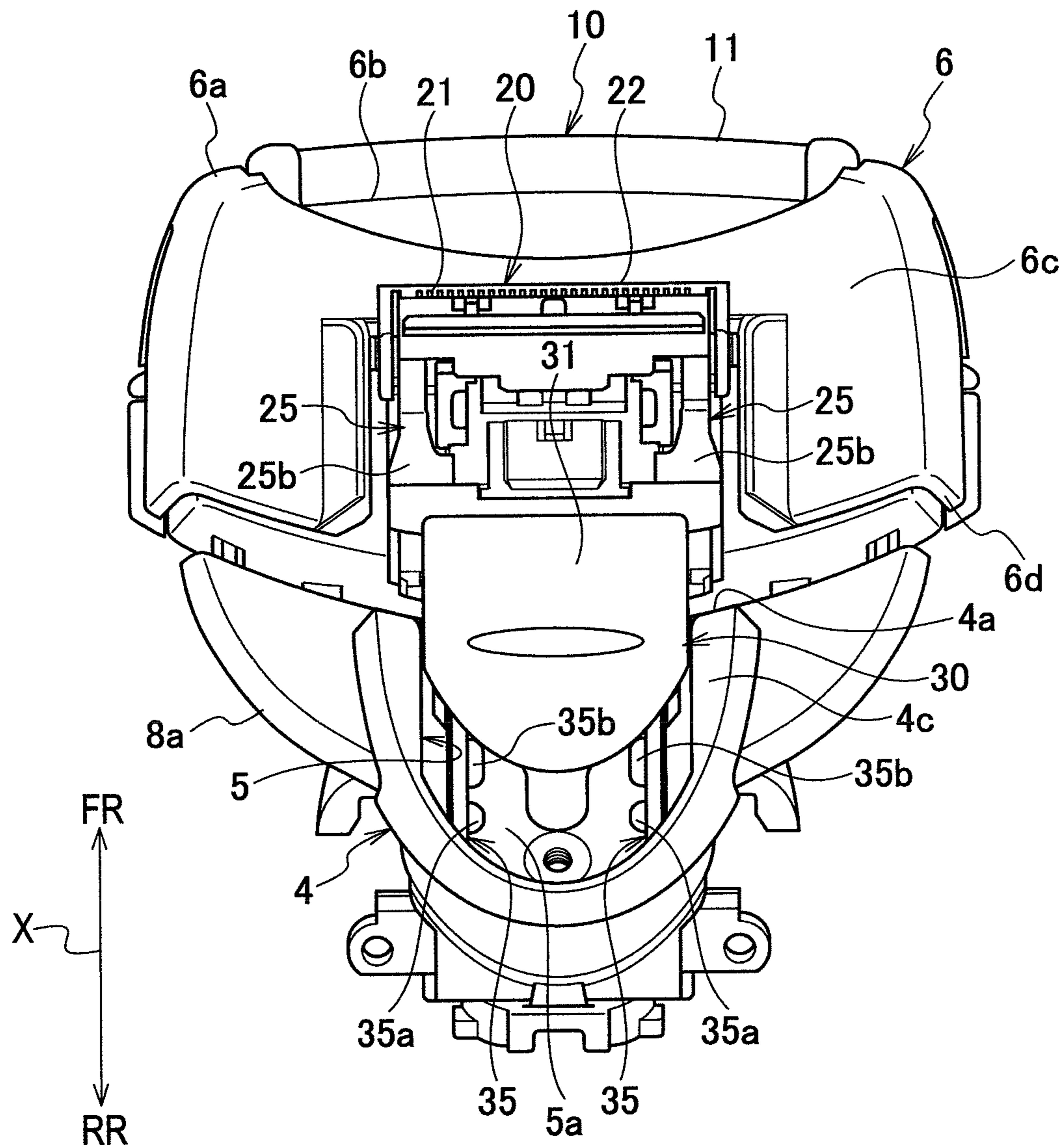

FIG. 9

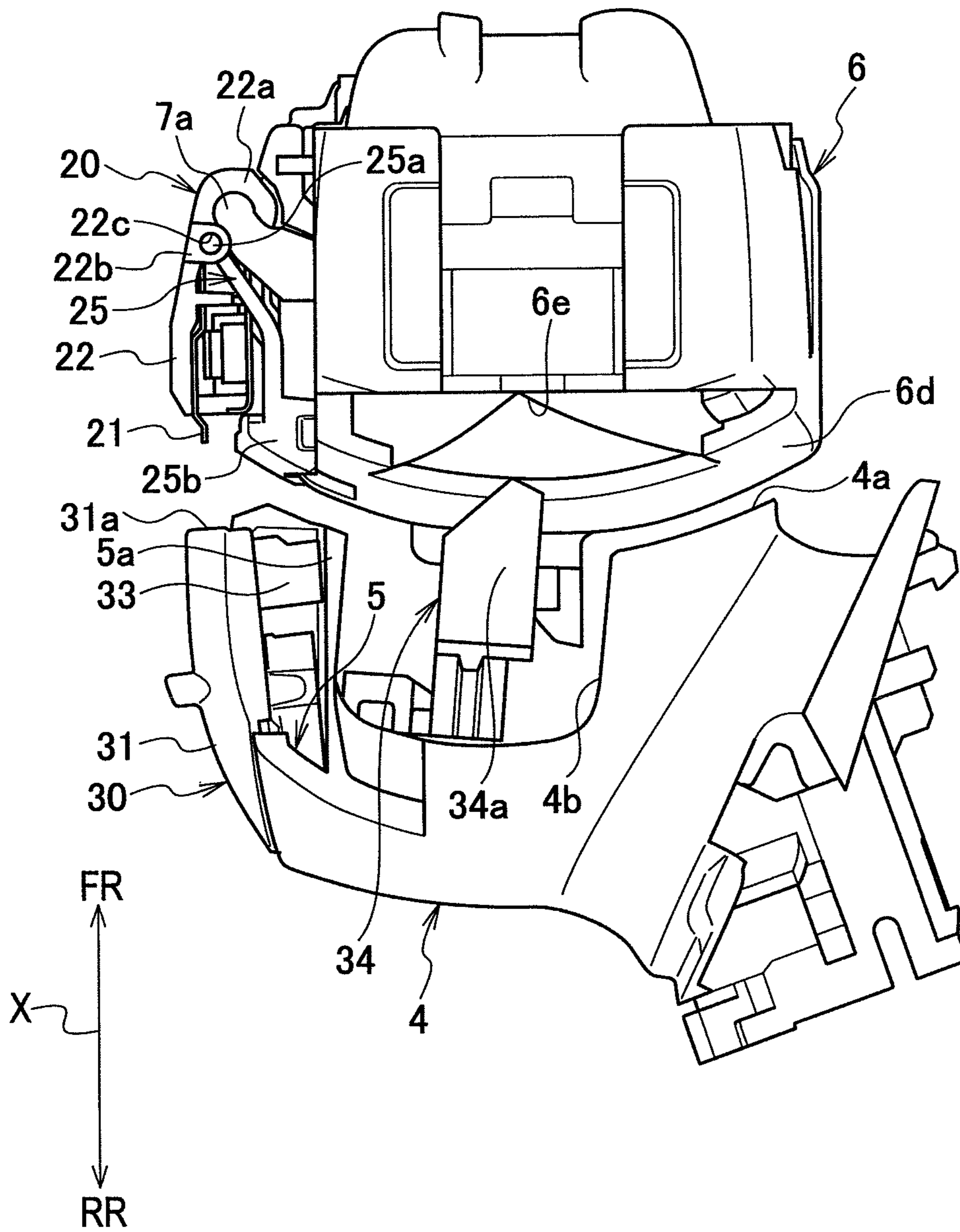

FIG. 10

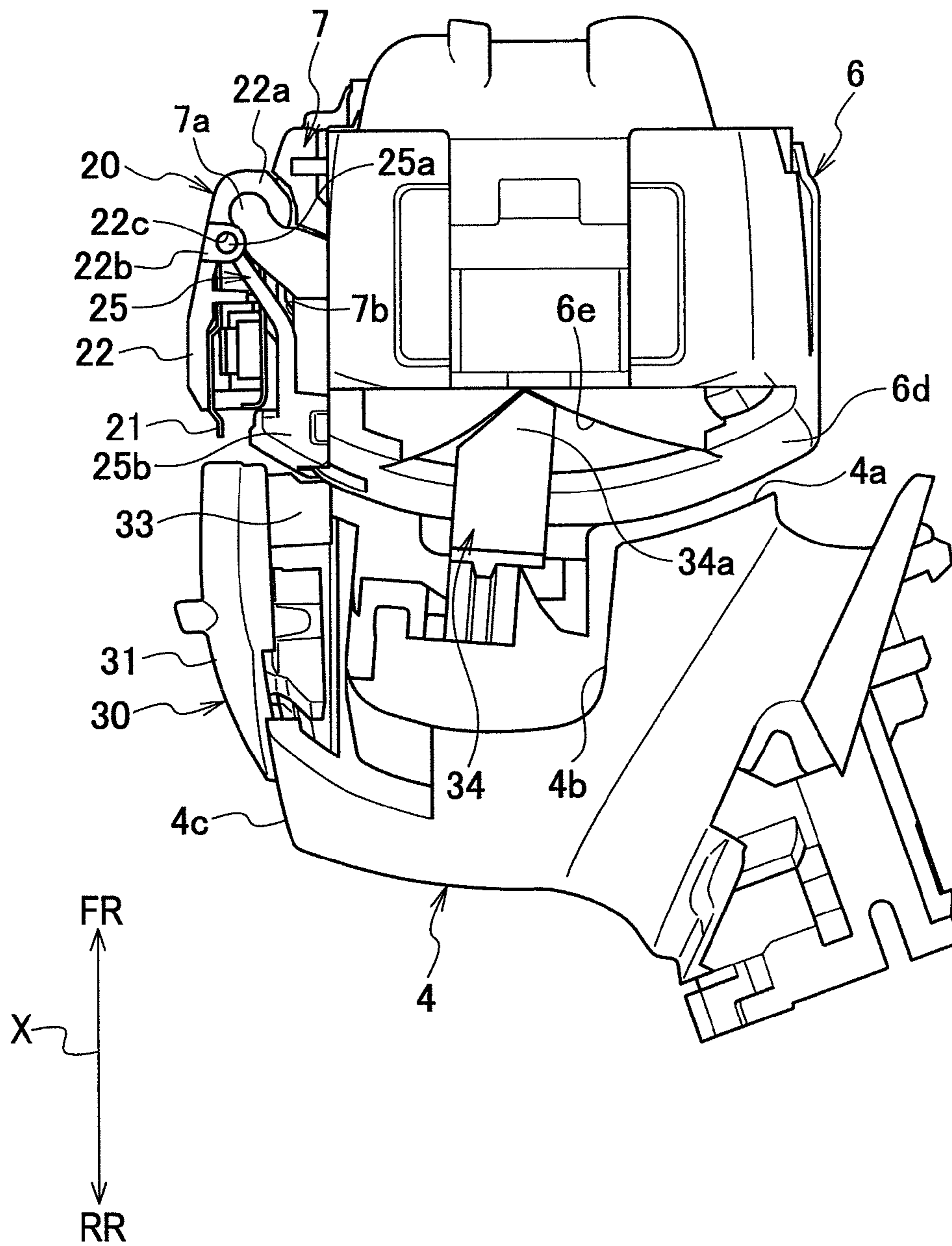

FIG. 11

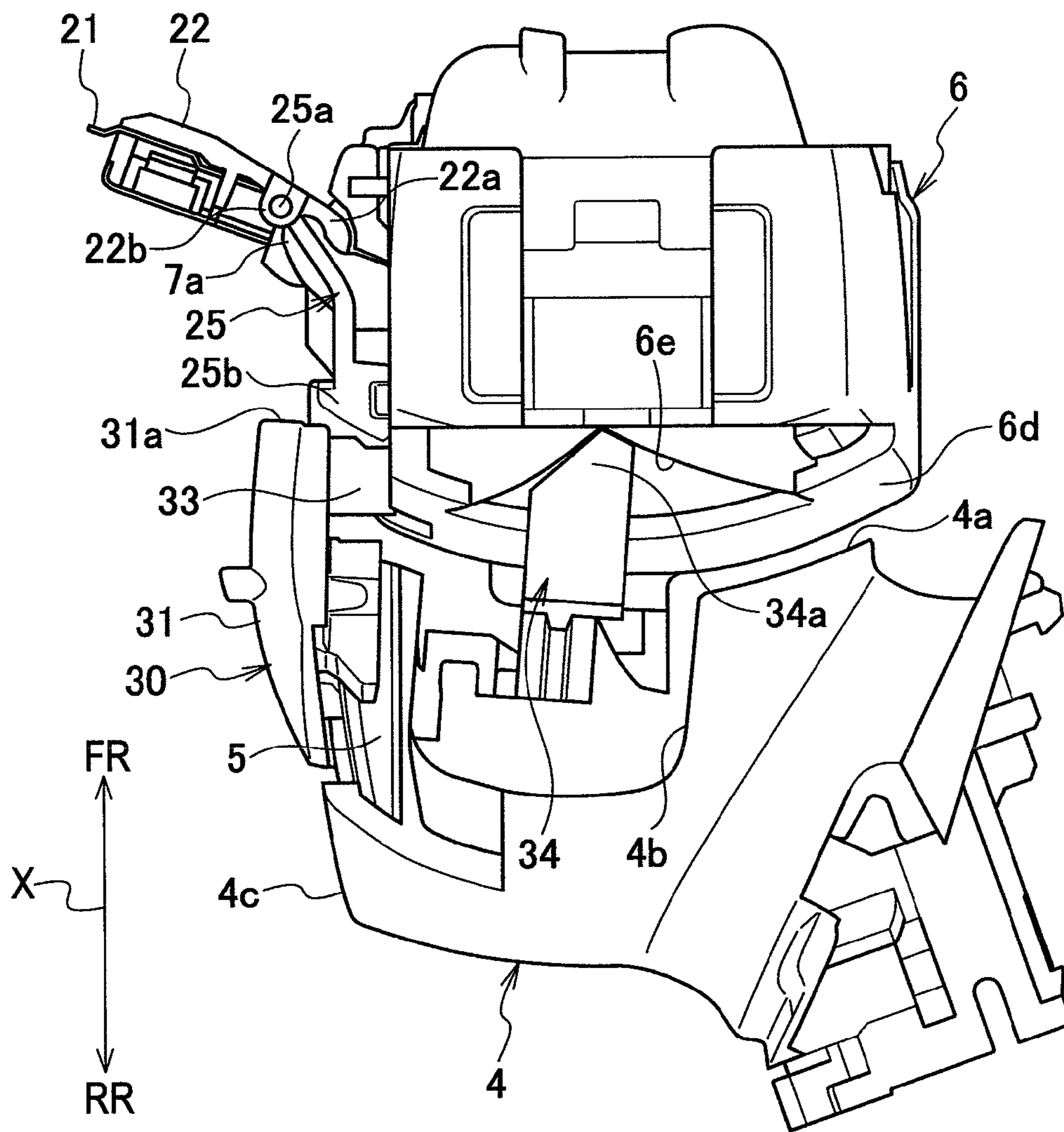



FIG. 13

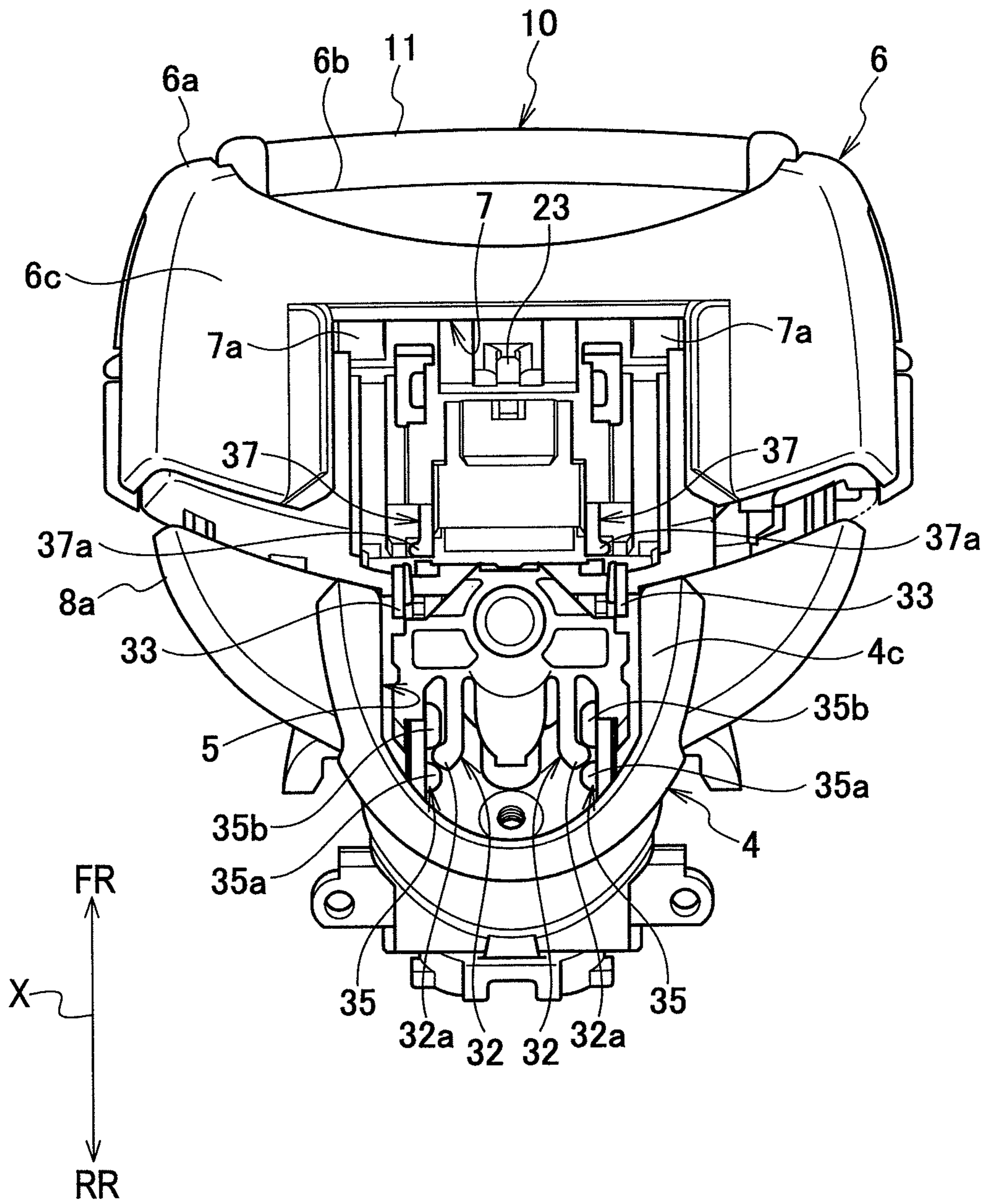

FIG. 14

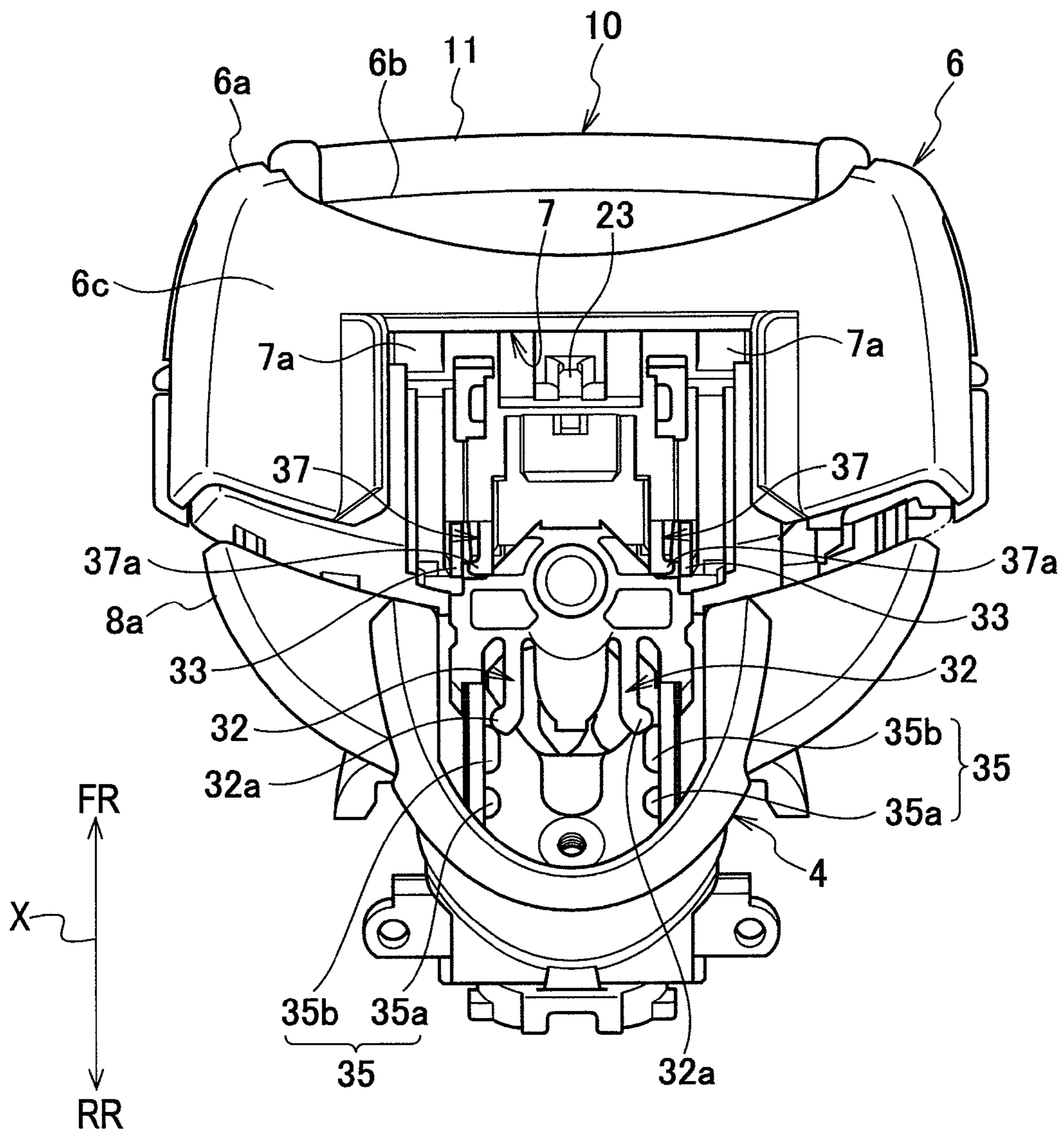



FIG. 15

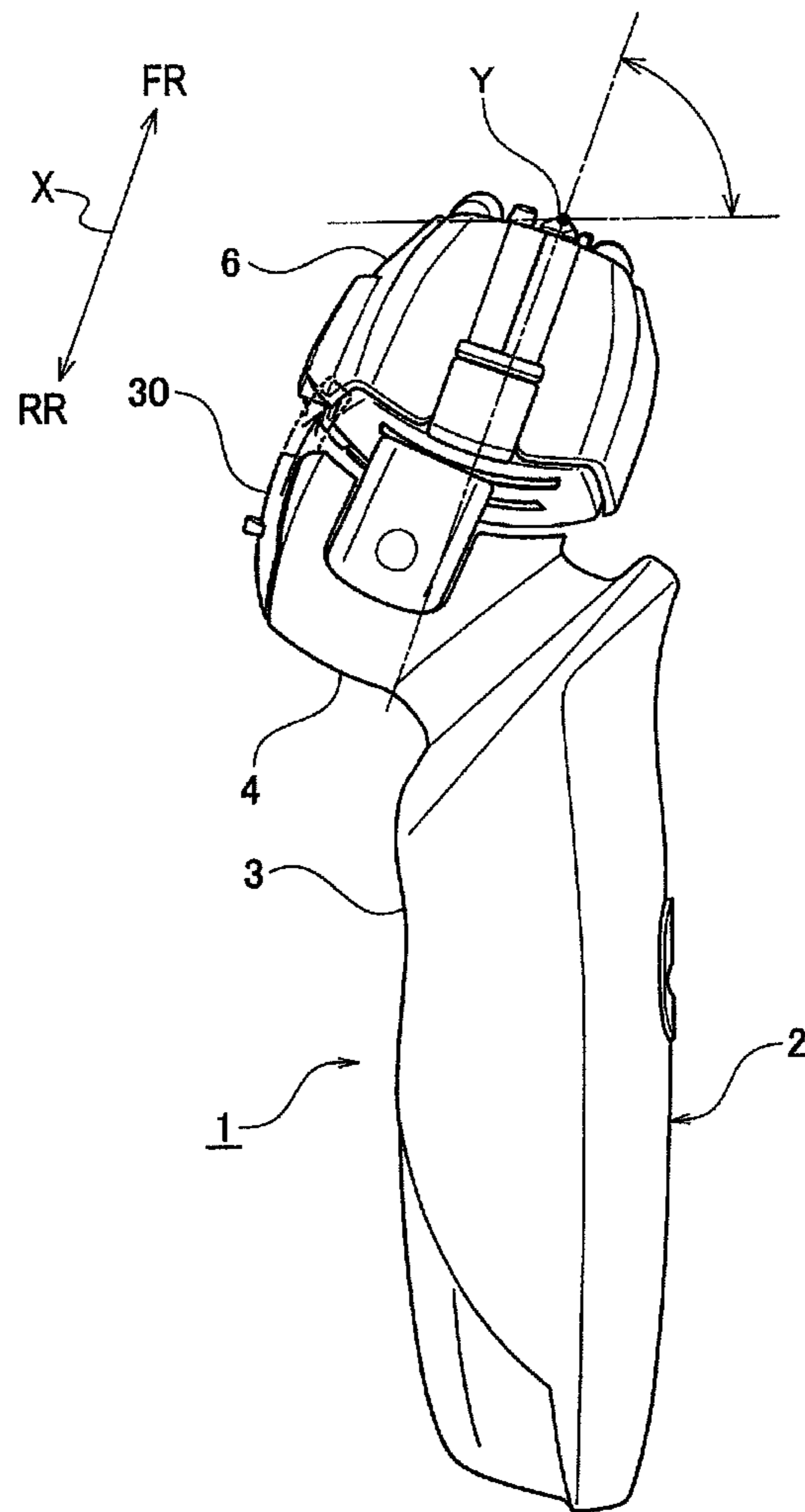
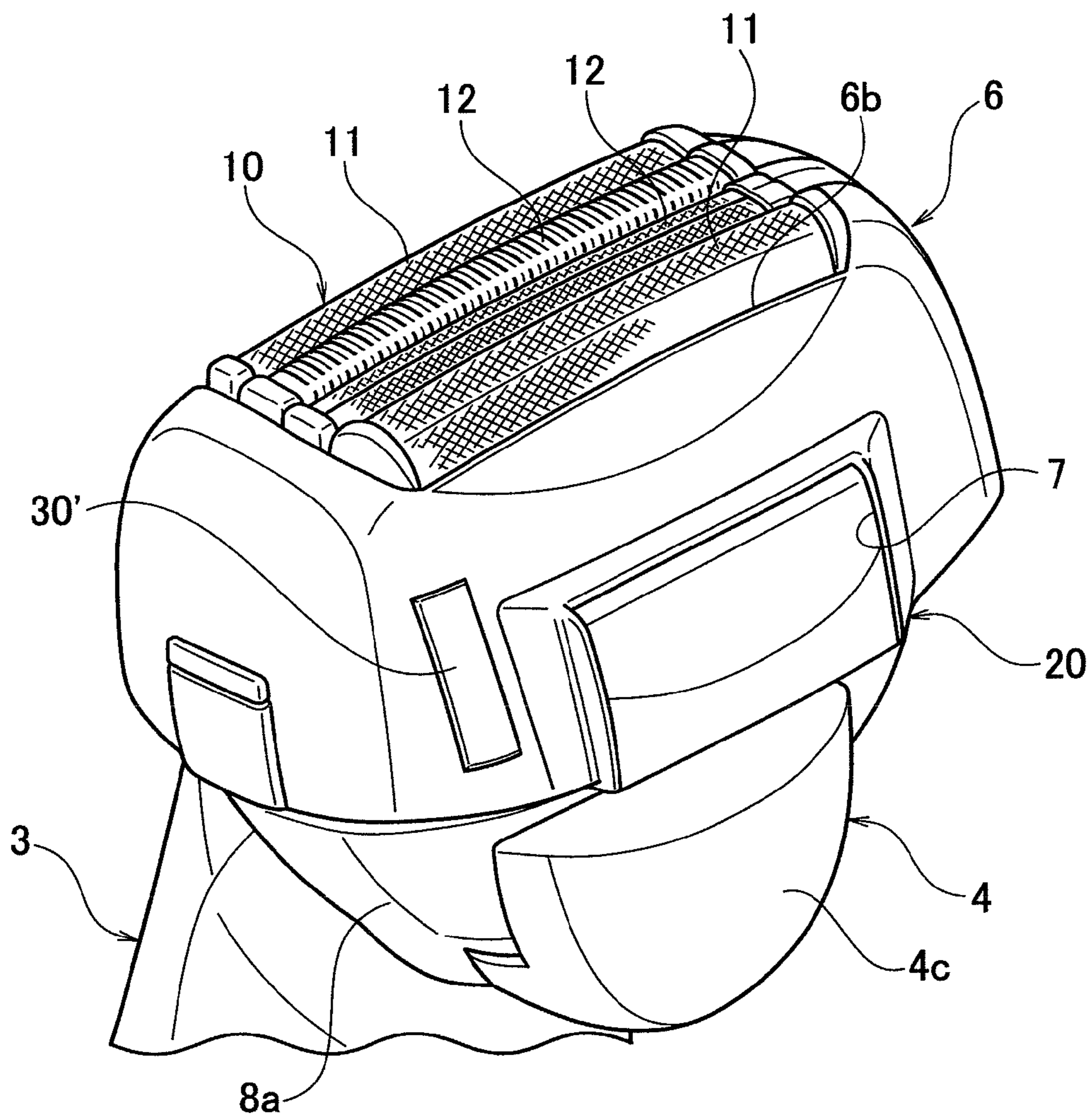

FIG. 16



# 1

## ELECTRIC SHAVER

### BACKGROUND OF THE INVENTION

#### 1. Field of the Invention

The present invention relates to an electric shaver in which a head portion holding a shaving-blade unit including an inner blade and an outer blade is supported to be swingable in predetermined directions with respect to a gripper portion.

#### 2. Description of the Related Art

Japanese Patent Application Publication No. 2002-315978 discloses an electric shaver of the above-mentioned kind, which includes not only a shaving-blade unit including an inner blade and an outer blade but also an edge-trimmer-blade unit.

The electric shaver includes a gripper portion to be held by the user's hand and a head portion configured to hold the shaving-blade unit, and supported to be swingable in the anteroposterior directions with respect to the gripper portion. Moreover, the electric shaver includes the edge-trimmer-blade unit in an upper-side portion on the back-side surface of the gripper portion. A switching knob is provided in the gripper portion to switch the edge-trimmer-blade unit between a ready-for-use state (a popped-up state) and a stored state.

### SUMMARY OF THE INVENTION

In the conventional electric shaver, however, the edge-trimmer-blade unit is provided in the upper-side portion on the back-side surface of the gripper portion, and thus its blade edge is away from the shaving-blade unit located in the top end of the head portion that swings in the anteroposterior directions. For this reason, the conventional electric shaver has a drawback of imposing a difficulty on a user in placing the edge-trimmer-blade unit on the exact point to be shaved.

An object of the present invention, made to solve the above-mentioned problem, is to provide an electric shaver in which an edge-trimmer-blade unit is provided in a head portion swinging in predetermined directions, thereby being capable of making the edge-trimmer-blade unit easier to use.

An aspect of the present invention is an electric shaver including: a gripper portion to be held by the user's hand; and a head portion configured to hold a shaving-blade unit and supported to be swingable in predetermined directions with respect to the gripper portion, wherein the head portion is provided with an edge-trimmer-blade unit.

### BRIEF DESCRIPTION OF THE DRAWINGS

FIG. 1 is a side view illustrating an electric shaver according to a first embodiment of the present invention

FIG. 2 is a perspective view illustrating a principal portion of the electric shaver.

FIG. 3 is a side view illustrating the principal portion of the electric shaver before the operation of an operation element.

FIG. 4 is a side view illustrating the principal portion of the electric shaver at the time of a first operation of the operation element.

FIG. 5 is a side view illustrating the principal portion of the electric shaver at the time of a second operation of the operation element.

FIG. 6 is a back-side view illustrating the principal portion of the electric shaver before the operation of the operation element.

# 2

FIG. 7 is a back-side view illustrating the principal portion of the electric shaver at the time of the first operation of the operation element.

FIG. 8 is a back-side view illustrating the principal portion of the electric shaver at the time of the second operation of the operation element.

FIG. 9 is a partially-sectional side view illustrating the principal portion of the electric shaver before the operation of the operation element.

FIG. 10 is a partially-sectional side view illustrating the principal portion of the electric shaver at the time of the first operation of the operation element.

FIG. 11 is a partially-sectional side view illustrating the principal portion of the electric shaver at the time of the second operation of the operation element.

FIG. 12 is a partially-sectional back-side view illustrating the principal portion of the electric shaver before the operation of the operation element.

FIG. 13 is a partially-sectional back-side view illustrating the principal portion of the electric shaver at the time of the first operation of the operation element.

FIG. 14 is a partially-sectional back-side view illustrating the principal portion of the electric shaver at the time of the second operation of the operation element.

FIG. 15 is a side view illustrating the directions of the operation of the operation element.

FIG. 16 is a perspective view illustrating a principal portion of an electric shaver according to a second embodiment of the present invention.

### DESCRIPTION OF THE PREFERRED EMBODIMENT

Some embodiments of the present invention will be described below by referring to the drawings.

As FIGS. 1 and 15 show, an electric shaver 1 according to a first embodiment of the present invention includes a gripper portion 2 and a head portion 6. The gripper portion 2 is the portion that the user grips with his/her hand. The head portion 6 holds a shaving-blade unit 10 and is supported by the gripper portion 2 in such a manner as to be swingable in the anteroposterior directions and/or in the lateral directions with respect to the gripper portion 2.

The gripper portion 2 includes a gripper main body 3 and a gripper connecting portion 4. The gripper main body 3 is made of a synthetic resin, and includes a front-side surface 3b, a back-side surface 3c, and an upper-side surface 3a. The upper-side surface 3a slopes downwards from the front-side surface 3b to the back-side surface 3c. The gripper connecting portion 4 is made of a synthetic resin, and protrudes obliquely upwards to the rear from the upper-side surface 3a of the gripper main body 3.

A recessed portion 4b is formed at the center, in the anteroposterior directions, of an upper-side surface 4a of the gripper connecting portion 4. A lateral swing mechanism 8 is provided in the recessed portion 4b, and is configured to swing the head portion 6 in the lateral directions with respect to the gripper portion 2. An anteroposterior swing mechanism 9 is provided between the lateral swing mechanism 8 and the head portion 6, and is configured to swing the head portion 6 in the anteroposterior directions with respect to the gripper portion 2.

In addition, as FIGS. 1 to 8 show, an opening portion 6b is formed in an upper-side surface 6a of the head portion 6, and the shaving-blade unit 10 is provided in the opening portion 6b. A recessed portion 7 is formed in a back-side surface 6c of

3

the head portion 6, and an edge-trimmer-blade unit 20 that has a substantially flat shape is provided in the recessed portion 7.

In addition, a recessed portion 5 is formed in a back-side surface 4c of the gripper connecting portion 4 of the gripper portion 2. An operation element 30 that is made of a synthetic resin is provided in the recessed portion 5. The operation element 30 is capable of sliding back and forth in directions that is substantially parallel with a bottom surface 5a of the recessed portion 5. Hereafter, the directions will be referred to as the sliding-motion directions X. With the reciprocating motions, the operation element 30 is configured to switch the states of the edge-trimmer-blade unit 20 between a state where the edge-trimmer-blade unit 20 is ready for use (i.e., popped-up state, a state where a plane that is parallel to a principal surface of the edge-trimmer-blade unit 20 intersects with a plane that is parallel to the back-side surface 6c of the head portion 6 in this embodiment) and a state where the edge-trimmer-blade unit 20 is retracted to be stored (i.e., folded-up state, a state where the principal surface of the edge-trimmer-blade unit 20 is substantially parallel with the back-side surface 6c of the head portion 6). Note that in the following description, a direction in which the operation element 30 comes closer to the head portion 6 is referred to as the forward direction in the sliding-motion direction X, whereas a direction in which the operation element 30 goes away from the head portion 6 is referred to as the backward direction in the sliding-motion direction X.

As FIGS. 3 to 8 show, the shaving-blade unit 10 includes plural net-shaped outer blades 11, 11 and plural slit outer blades 12, 12. The net-shaped outer blades 11, 11 and the slit outer blades 12, 12 are exposed outside from the opening portion 6b of the head portion 6. Hairs introduced into the outer blades 11, 12 are cut by inner blades (not illustrated) that are moved back and forth in the lateral directions by the driving element of a linear motor (not illustrated) provided in the head portion 6.

As FIGS. 6 to 11 show, the edge-trimmer-blade unit 20 includes an edge-trimmer blade 21 and a blade holder 22. The edge-trimmer blade 21 is provided at the leading end of the edge-trimmer-blade unit 20. The blade holder 22, which is made of a synthetic resin, holds the edge-trimmer blade 21 and serves also as the cover for the edge-trimmer blade 21. A driving lever 23 (driving element) is connected to the linear motor, and is engaged to a central portion of the base-end portion of the edge-trimmer blade 21. Reciprocating lateral motions of the driving lever 23 make the edge-trimmer blade 21 move back and forth in the lateral directions with respect to the head portion 6. The blade holder 22 includes arc-shaped portions 22a, 22a at the two side-end portions in the lateral directions of the base-end portion. To rotatably support the arc-shaped portions 22a, 22a, a pair of pivot shafts 7a, 7a are formed in such a manner as to protrude respectively from the two side-end portions in the lateral directions of the recessed portion 7 of the head portion 6. In addition, a pair of protruding pieces 22b, 22b are formed as integral part of the blade holder 22 in such a manner as to protrude from positions located respectively in the two sides in the lateral directions of the base-end portion of the blade holder 22. The position where each protruding piece 22b is formed is closer to the leading end of the blade holder 22 than each arc-shaped portion 22a is. A circular hole 22c is formed in each of the protruding pieces 22b, 22b. A pair of handle arms 25, 25 are provided in the recessed portion 7 of the head portion 6. Each handle arm 25 is configured to slide back and forth in the sliding-motion directions X along the corresponding one of the two side edges in the lateral directions of a bottom surface 7b of the recessed portion 7. A pin portion 25a is formed in

4

such a manner as to protrude from the leading end of each handle arm 25. Each pin portion 25a is fitted to the circular hole 22c of the corresponding protruding piece 22b so as to move pivotally. Accordingly, when a base-end portion 25b of each handle arm 25 is pushed forward in the sliding-motion direction X by a surface 31a of an operation element main body 31 and a second-click elastic leg 33, which are to be described later, each handle arm 25 moves forward in the sliding-motion direction X (to a second position shown in FIG. 11). With the forward motion of the handle arms 25, 25, the blade holder 22 moves rotationally about the pivot shafts 7a, 7a to pop up. When the pushing force of the operation element 30 is released, a biasing force exerted by an unillustrated spring member moves each handle arm 25 backward in the sliding-motion direction X. While each handle arm 25 is moving back to the original position (i.e., back to the first position shown in FIG. 10), the handle arm 25 moves rotationally the blade holder 22 about the pivot shafts 7a, 7a in the opposite direction, so that the blade holder 22 is retracted back into the recessed portion 7 of the head portion 6.

As FIGS. 3 to 15 show, the operation element 30 includes: the operation element main body 31; a pair of first-click elastic legs 32, 32; the pair of second-click elastic legs 33, 33; and a locking member 34. The operation element main body 31 is made of a synthetic resin, and is capable of sliding back and forth in the sliding-motion directions X in the recessed portion 5 formed in the back-side surface 4c of the gripper connecting portion 4 of the gripper portion 2. The first-click elastic legs 32, 32 are made of a synthetic resin, and protrude from the back-side surface of the operation element main body 31 in such a manner as to extend backward in the sliding-motion direction X. The second-click elastic legs 33, 33 are made of a synthetic resin, and protrude from the back-side surface of the operation element main body 31 in such a manner as to extend forward in the sliding-motion direction X. The locking member 34 is made of a synthetic resin, and is connected to the back-side surface of the operation element main body 31. The first-click elastic legs 32, 32 and the second-click elastic legs 33, 33 are configured to slide back and forth in the sliding-motion directions X on the bottom surface 5a in the recessed portion 5 of the gripper connecting portion 4 along with the reciprocating sliding motions of the operation element main body 31. The locking member 34 has a square U-shape with an open side facing forward in the sliding-motion direction X when viewed from the front side (i.e., when viewed from the front-surface side of the operation element main body 31). The locking member 34 protrudes from the two side-portions in the lateral directions of the gripper connecting portion 4 into a lateral-swing cover 8a of the lateral swing mechanism 8.

As FIGS. 3 to 5 and FIG. 15 show, the operation element main body 31 of the operation element 30 is configured to slide back and forth following an arc-shaped trajectory in the recessed portion 5 of the gripper connecting portion 4 of the gripper portion 2. The arc-shaped trajectory on which the operation element main body 31 moves when sliding back and forth can be described in the following way. As FIG. 15 shows, the further forwards the operation element main body 31 moves forward in the sliding-motion direction X, the closer the operation element main body 31 gets to a rotating axis Y for the anteroposterior swinging motions of the head portion 6.

As FIG. 12 shows, a pair of first-click portions 35, 35 (click portions) are formed respectively on the two side-portions in the lateral directions in the recessed portion 5 of the gripper connecting portion 4. Each of the pair of first-click portions 35, 35 includes a first protruding portion 35a and a second

## 5

protruding portion **35b**. The first protruding portion **35a** protrudes from the corresponding side wall, in the lateral direction, of the recessed portion **5** towards the center in the lateral direction. The second protruding portion **35b** also protrudes from the corresponding side wall, in the lateral direction, of the recessed portion **5** towards the center in the lateral direction, but is located forward in the sliding-motion direction X of the first protruding portion **35a**.

Leading-end protruding portions **32a**, **32a** are formed respectively in the backward portions, backward in the sliding-motion direction X, of the first-click elastic legs **32**, **32**. Before the user operates the operation element **30**, that is, while the operation element **30** is at the ordinary position (third position) shown in FIGS. **1** to **3**, and also in FIGS. **6**, **9**, and **12**, each leading-end protruding portion **32a** abuts on the backward-end portion, in the sliding-motion directions X, of the corresponding first protruding portion **35a**. In this state, the head portion **6** is capable of swinging in the anteroposterior directions and/or in the lateral directions with respect to the gripper portion **2**. In addition, each handle arm **25** is held at the ordinary position (first position) by the biasing force exerted by the unillustrated spring member.

In addition, at the time of a first operation (first click) of the operation element **30**, that is, when the operation element **30** slides forward in the sliding-motion direction X from the ordinary position and reaches a first-click position shown in FIGS. **4**, **7**, **10**, and **13**, each of the leading-end protruding portions **32a**, **32a** of the first-click elastic legs **32**, **32** is fitted to the space formed between the forward-end portion, in the sliding-motion directions X, of the corresponding first protruding portion **35a** and the backward-end portion, in the sliding-motion directions X, of the corresponding second protruding portion **35b**, as FIG. **13** shows.

In this state, as FIG. **10** shows, two leading-end portions **34a**, **34a** of the locking member **34** are fitted respectively to a pair of recessed portions **6e**, **6e** that are formed respectively on the two side-portions of a bottom surface **6d** of the head portion **6**. With the fitting of the leading-end portions **34a**, **34a** to the recessed portions **6e**, **6e**, the head portion **6** is locked in a fixed position with respect to the gripper connecting portion **4** of the gripper portion **2**.

In addition, at the time of a second operation (second click) of the operation element **30**, that is, when the operation element **30** slides further forward in the sliding-motion direction X from the first-click position and reaches a second-click position (a fourth position) shown in FIGS. **5**, **8**, **11**, and **14**, each of the leading-end protruding portions **32a**, **32a** of the first-click elastic legs **32**, **32** abuts on the forward-end portion, in the sliding-motion directions X, of the corresponding second protruding portion **35b**, as FIG. **14** shows. In addition, each of the second-click elastic legs **33**, **33** abuts on the corresponding one of protruding portions **37a**, **37a** of a pair of second-click portions **37**, **37** (click portions for fixing the head portion **6**) that protrude from the bottom surface **7b** of the recessed portion **7** of the head portion **6**.

In this state, as FIGS. **5**, **8**, and **11** show, each handle arm **25** is pushed forward in the sliding-motion direction X by the surface **31a** of the operation element main body **31** and the corresponding second-click elastic leg **33**. Thereby, the state of the edge-trimmer-blade unit **20** is switched from the retracted state where the edge-trimmer-blade unit **20** is stored in the recessed portion **7** of the head portion **6** to the popped-up state where the edge-trimmer-blade unit **20** is ready for use.

As FIGS. **4**, **7**, **10** and **13** show, according to the electric shaver **1** of the embodiment, as the operation element **30** is operated to slide forwards towards the bottom surface **6d** of

## 6

the head portion **6**, at the time of the first operation (first click), each of the leading-end protruding portions **32a**, **32a** of the pair of first-click elastic legs **32**, **32** is fitted to the space formed between the first protruding portion **35a** and the second protruding portion **35b** of the corresponding one of the pair of first-click portions **35**, **35** that are formed respectively on the two side-portions of the recessed portion **5** of the gripper connecting portion **4**. In addition, the two leading-end portions **34a**, **34a** of the locking member **34** are fitted respectively to the pair of recessed portions **6e**, **6e** that are formed respectively in the two side-portions of the bottom surface **6d** of the head portion **6**. Accordingly, the head portion **6** is locked so as to be prohibited from swinging with respect to the gripper portion **2**. Consequently, the head portion **6** is fixed to a position with respect to the gripper portion **2**.

In addition, as FIGS. **5**, **8**, **11**, and **14** show, as the operation element **30** is operated to slide forwards further towards the bottom surface **6d** of the head portion **6**, at the time of the second operation (second click), each of the leading-end protruding portions **32a**, **32a** of the pair of first-click elastic legs **32**, **32** abuts on the corresponding one of the second protruding portions **35b**, **35b** of the pair of first-click portions **35**, **35** that protrude in the recessed portion **5** of the gripper connecting portion **4**. In addition, each of the pair of second-click elastic legs **33**, **33** abuts on the corresponding one of the protruding portions **37a**, **37a** of the pair of second-click portions **37**, **37** that protrude from the bottom surface **7b** of the recessed portion **7** of the head portion **6**. Accordingly, the head portion **6** is locked so as to be prohibited completely from swinging with respect to the gripper portion **2**. Consequently, the head portion **6** can be reliably prevented from shaking.

As FIGS. **5**, **8**, and **11** show, at the time of the second operation (second click), the handle arms **25**, **25** in the recessed portion **7** of the head portion **6** are pushed forward in the sliding-motion direction X by the operation element **30**. Accordingly, the state of the edge-trimmer-blade unit **20** that has been stored in the recessed portion **7** of the head portion **6** is switched to the state where the edge-trimmer-blade unit **20** is popped up to be ready for use. If the operation element **30** is operated to slide backwards from the popped-up state, the handle arms **25**, **25** are moved back to their respective original positions by the biasing force of the unillustrated spring member. Accordingly, the edge-trimmer-blade unit **20** is retracted to be stored in the recessed portion **7** of the head portion **6**.

Since the edge-trimmer-blade unit **20** is provided in the recessed portion **7** of the head portion **6** in such a manner as to be capable of being retracted freely to be stored and of being popped up freely, the edge-trimmer-blade unit **20** becomes easier to use. In particular, since the edge-trimmer-blade unit **20** is provided in the head portion **6**, which is close to the blade surfaces of the outer blades **11**, **12** of the shaving-blade unit **10**, the edge-trimmer-blade unit **20** becomes even easier to use.

In addition, since the operation element **30** to switch the states of the edge-trimmer-blade unit **20** between the ready-for-use state and the stored state is provided in the gripper portion **2**, the operation element **30** can be kept away and separated from the head portion **6**. Accordingly, even with the edge-trimmer-blade unit **20**, the head portion **6** can be made smaller in size.

In addition, the head portion **6** is locked with respect to the gripper portion **2** by the first operation (first click) of the operation element **30**, and the edge-trimmer-blade unit is switched to the ready-for-use state by the second operation (second click) of the operation element **30**. Accordingly, the

locking of the head portion 6 and the switching of the state of the edge-trimmer-blade unit 20 to the ready-for-use state can be done simply and reliably using the single operation element 30. Consequently, the electric shaver 1 can be manufactured at even lower cost and the head portion 6 can be made even smaller in size.

In addition, the head portion 6 is locked with respect to the gripper portion 2 simultaneously with the switching of the state of the edge-trimmer-blade unit 20 to the ready-for-use state by the operation of the operation element 30. Accordingly, the point that the operation element 30 has to operate on can be limited to a single point within the recessed portion 5 of the gripper connecting portion 4 of the gripper portion 2. Consequently, the head portion 6 can be made smaller in size. In addition, the switching of the state of the edge-trimmer-blade unit 20 to or from the ready-for-use state and the operation of locking or unlocking the head portion 6 can be done simultaneously by the operation of the single operation element 30.

FIG. 16 is a perspective view illustrating a principal portion of an electric shaver according to a second embodiment of the present invention.

The second embodiment differs from the first embodiment in that an operation element 30' configured to switch the state of the edge-trimmer-blade unit 20 between the ready-for-use state and the stored state is provided in the head portion 6. The other portions in the configuration of the second embodiment are identical to their respective counterparts in the configuration of the first embodiment. So, the same reference numerals as those used in the first embodiment are given to the identical constituent portions in the second embodiment, and no detailed description for the identical portions will be given.

In this second embodiment, the operation element 30' configured to switch the state of the edge-trimmer-blade unit 20 between the ready-for-use state and the stored state is provided in the head portion 6. Accordingly, there is no operation portion in the gripper portion 2, and thereby the gripper portion 2 becomes easier to grip. In addition, the edge-trimmer-blade unit 20 and the operation element 30' are provided in the head portion 6, so that the driving portion such as the driving lever of the edge-trimmer-blade unit 20 can be stably engaged appropriately when necessary.

The preferred embodiments described herein are illustrative and not restrictive, and the invention may be practiced or embodied in other ways without departing from the spirit or essential character thereof.

A first aspect of the present invention provides an electric shaver including: a gripper portion to be held by the user's hand; and a head portion configured to include a shaving blade and supported to be swingable in predetermined directions with respect to the gripper portion. In the electric shaver, the head portion includes an edge-trimmer-blade unit.

According to the first aspect of the present invention, since the edge-trimmer-blade unit is provided in the head portion, the edge-trimmer-blade unit can be made easier to use. In particular, since the edge-trimmer-blade unit is provided in the head portion that is close to the blade surfaces of the shaving-blade unit, the electric shaver can be made even easier to use.

A second aspect of the present invention provides the electric shaver according to the first aspect with the following additional feature. The gripper portion includes an operation element configured to switch the edge-trimmer-blade unit between a ready-for-use state and a stored state.

According to the second aspect of the present invention, since the operation element is provided in the gripper portion, the operation element can be separated or placed at a position

away from the head portion. Consequently, even with the edge-trimmer-blade unit, the head portion can be made smaller in size.

A third aspect of the present invention provides the electric shaver according to the second aspect with the following additional features. The head portion is locked with respect to the gripper portion by a first operation of the operation element. The edge-trimmer-blade unit is switched to the ready-for-use state by a second operation of the operation element.

According to the third aspect of the present invention, the locking of the head portion and the switching of the state of the edge-trimmer-blade unit to and from the ready-for-use state can be done using only the single operation element. Consequently, the electric shaver can be manufactured at lower cost and the head portion can be made even smaller in size.

A fourth aspect of the present invention provides the electric shaver according to the second aspect with the following additional feature. The head portion is locked in the position with respect to the gripper portion simultaneously with the switching of the edge-trimmer-blade unit to the ready-for-use state by the operation of the operation element.

According to the fourth aspect of the present invention, since the operation point of the operation element can be limited to a single point, the head portion can be made smaller in size. In addition, the operation of switching the state of the edge-trimmer-blade unit to and from the ready-for-use state and the operation of locking and unlocking the head portion can be done simultaneously by the operation of the single operation element.

A fifth aspect of the present invention provides the electric shaver according to the first aspect with the following additional feature. The head portion includes an operation element configured to switch the edge-trimmer-blade unit between a ready-for-use state and a stored state.

According to the fifth aspect of the present invention, the provision of the operation element in the head portion can eliminate the operation portion from the gripper portion. Consequently, the gripper portion can be made easier to grip. In addition, since the edge-trimmer-blade unit and the operation element are provided in the head portion, the driving portion of the edge-trimmer-blade unit can be stably fitted appropriately when necessary.

A sixth aspect of the present invention provides the electric shaver according to the second aspect with the following additional features. The edge-trimmer-blade unit is linked to a handle arm slidable on the head portion, in such a manner that the edge-trimmer-blade unit is in the stored state when the handle arm is at a first position and that the edge-trimmer-blade unit is in the ready-for-use state when the handle arm is at a second position. The operation element is slidable on the gripper portion between a third position and a fourth position. The third position is where the operation element allows the head portion to swing with respect to the gripper portion and the handle arm to be located at the first position. The fourth position is where the operation element engages with the handle arm so as to hold the handle arm at the second position.

According to the sixth aspect of the present invention, the handle arm provided in the head portion can be moved to the second position by sliding the operation element provided in the gripper portion to the fourth position. Consequently, even if the operation element is provided separately at a position away from the head portion, the edge-trimmer-blade unit can be made ready for use by a simple operation.

The present disclosure relates to subject matters contained in Japanese Patent Application No. 2009-006374, filed on

9

Jan. 15, 2009, the disclosures of which is expressly incorporated herein by reference in its entirety.

What is claimed is:

1. An electric shaver, comprising:

a gripper portion to be held by a user's hand;  
a head portion configured to hold a shaving-blade unit and supported to be swingable in predetermined directions with respect to the gripper portion;

a locking member which is connected to an operation element, and

a rotatable edge-trimmer-blade unit supported on the head portion and configured to be rotated by the operation element between a ready-for-use state where the edge-trimmer blade unit is in a popped up position and a stored state where the edge-trimmer blade unit is in a retracted position, wherein

the head portion includes a recessed portion formed in a back-side surface of the head portion, and the edge-trimmer blade unit is stored in the recessed portion when the edge-trimmer-blade unit is in the stored state.

2. The electric shaver according to claim 1, wherein

the operation element is movable between an ordinary position in which a pair of first-click legs of the operation element abut rear portions of a pair of first-click portions of the gripper portion, a first-click position in which the pair of first-click legs abut forward portions of the pair of first-click portions, and a second-click position in which the pair of first-click legs abut forward portions of a pair of second-click portions of the gripper portion;

the head portion is configured to swing with respect to the gripper portion, and the edge-trimmer-blade unit is in the stored state when the operation element is in the ordinary position,

the locking member locks the head portion with respect to the gripper portion and the edge-trimmer-blade unit is in the stored state when the operation element is at the first-click position, and

10

the locking member locks the head portion with respect to the gripper portion and the edge-trimmer-blade unit is in the ready-for-use state when the operation element is at a the second-click position.

3. The electric shaver according to claim 1, wherein

the operation element is movable between an ordinary position in which a pair of first-click legs of the operation element abut rear portions of a pair of first-click portions of the gripper portion, a first-click position in which the pair of first-click legs abut forward portions of the pair of first-click portions, and a second-click position in which the pair of first-click leg. forward portions of a pair of second-click portions of the gripper portion;

the head portion is configured to swing with respect to the gripper portion, and the edge-trimmer-blade unit is in the stored state when the operation element is in the ordinary position, and

the locking member locks the head portion with respect to the gripper portion and the edge-trimmer-blade unit is in the ready-for-use state when the operation element is at a the second-click position.

4. The electric shaver according to claim 1,

wherein the edge-trimmer-blade unit is linked to a handle arm slidable on the head portion, in such a manner that the edge-trimmer-blade unit is in the stored state when the handle arm is at a first position and that the edge-trimmer-blade unit is in the ready-for-use state when the handle arm is at a second position, and

the operation element is slidable on the gripper portion between an ordinary position where the operation element allows the head portion to swing with respect to the gripper portion and the handle arm to be located at the first position, and a position where the operation element engages with the handle arm so as to hold the handle arm at the second position.

\* \* \* \* \*