



US008653308B2

(12) **United States Patent**
Hale et al.(10) **Patent No.:** **US 8,653,308 B2**
(45) **Date of Patent:** ***Feb. 18, 2014**(54) **PROCESS FOR UTILIZING A WATER
STREAM IN A HYDROLYSIS REACTION TO
FORM ETHANOL**(71) Applicant: **Celanese International Corporation,**
Irving, TX (US)(72) Inventors: **Trinity Horton Hale,** Houston, TX
(US); **Radmila Wollrab,** Pasadena, TX
(US); **Victor J. Johnston,** Houston, TX
(US); **Lincoln Sarager,** Houston, TX
(US); **R. Jay Warner,** Houston, TX
(US); **Heiko Weiner,** Pasadena, TX (US)(73) Assignee: **Celanese International Corporation,**
Dallas, TX (US)(*) Notice: Subject to any disclaimer, the term of this
patent is extended or adjusted under 35
U.S.C. 154(b) by 0 days.This patent is subject to a terminal dis-
claimer.(21) Appl. No.: **13/772,757**(22) Filed: **Feb. 21, 2013**(65) **Prior Publication Data**

US 2013/0224102 A1 Aug. 29, 2013

Related U.S. Application Data(63) Continuation of application No. 13/542,309, filed on
Jul. 5, 2012, now Pat. No. 8,399,719, which is a
continuation of application No. 12/852,297, filed on
Aug. 6, 2010, now Pat. No. 8,222,466.(60) Provisional application No. 61/300,815, filed on Feb.
2, 2010, provisional application No. 61/332,696, filed
on May 7, 2010, provisional application No.
61/332,699, filed on May 7, 2010, provisional
application No. 61/332,728, filed on May 7, 2010,
provisional application No. 61/346,344, filed on May
19, 2010.(51) **Int. Cl.**
C07C 27/26 (2006.01)
C07C 29/80 (2006.01)(52) **U.S. Cl.**
USPC **568/885**; 568/913; 568/918(58) **Field of Classification Search**
USPC 568/885, 913, 918
See application file for complete search history.(56) **References Cited**

U.S. PATENT DOCUMENTS

1,469,447 A 10/1923 Schneible
1,939,116 A 12/1933 Fuchs
2,021,698 A 11/1935 Perkins
2,105,540 A 1/1938 Lazier
2,192,137 A 2/1940 Kvalnes
2,549,416 A 4/1951 Brooks
2,591,671 A 4/1952 Catterall2,591,672 A 4/1952 Catterall
2,607,719 A 8/1952 Eliot et al.
2,607,807 A 8/1952 Ford
2,649,407 A 8/1953 Harrison et al.
2,702,783 A 2/1955 Harrison et al.
2,715,604 A 8/1955 Weaver, Jr.
2,744,939 A 5/1956 Kennel
2,801,209 A 7/1957 Muller et al.
2,882,244 A 4/1959 Milton
3,130,007 A 4/1964 Breck
3,404,186 A 10/1968 Bailey et al.
3,408,267 A 10/1968 Miller et al.
3,445,345 A 5/1969 Katzen et al.
3,478,112 A 11/1969 Karl et al.
3,702,886 A 11/1972 Argauer et al.
3,729,429 A 4/1973 Robson
3,990,952 A 11/1976 Katzen et al.
4,065,512 A 12/1977 Cares
4,228,307 A 10/1980 Zimmerschied
4,270,015 A 5/1981 Knifton
4,275,228 A 6/1981 Gruffaz et al.
4,306,942 A 12/1981 Brush et al.
4,317,918 A 3/1982 Takano et al.
4,319,058 A 3/1982 Kulprathipanja et al.
4,337,351 A 6/1982 Larkins, Jr.
4,352,940 A 10/1982 Adelman et al.
4,374,265 A 2/1983 Larkins, Jr.
4,379,028 A 4/1983 Berg et al.
4,395,576 A 7/1983 Kwantes et al.
4,398,039 A 8/1983 Pesa et al.

(Continued)

FOREIGN PATENT DOCUMENTS

CN 1230458 10/1999
CN 201768393 3/2011

(Continued)

OTHER PUBLICATIONS

Zheng, et al. (2007). Preparation and catalytic properties of a bime-
talic Sn—Pt complex in the supercages of NaY zeolite by use of
surface organometallic chemistry, *Applied Organometallic Chemis-*
try, 21(10), 836-840.ZeaChem, Inc., Technology Overview, Lakewood, Colorado www.
zeachem.com, 2008.Santori et al.(2000). Hydrogenation of carbonylic compounds on
Pt/SiO₂ catalysts modified with SnBu₄, *Studies in Surface Science*
and Catalysis, 130, 2063-2068.Rachmady, Acetic Acid Reduction by H₂ on Bimetallic Pt—Fe Cata-
lysts, *Journal of Catalysis* 209, 87-98 (Apr. 1, 2002), Elsevier Science
(USA).Pestman et al., The formation of ketones and aldehydes from
carboxylic acids, structure-activity relationship for two competitive
reactions, *Journal of Molecular Catalysis A: Chemical* 103 Jun. 14,
1995, 175-180.

(Continued)

Primary Examiner — Elvis O Price(57) **ABSTRACT**In one embodiment, the invention is to a process for produc-
ing a water stream comprising the steps of hydrogenating
acetic acid to form a crude ethanol product and separating at
least a portion of the crude ethanol product in at least one
column of a plurality of columns into a distillate comprising
ethanol and a residue comprising the water stream. The water
stream preferably is essentially free of organic impurities
other than acetic acid and ethanol.**20 Claims, 2 Drawing Sheets**

(56)

References Cited

U.S. PATENT DOCUMENTS

4,399,305 A	8/1983	Schreck	5,599,976 A	2/1997	Scates et al.
4,421,939 A	12/1983	Kiff et al.	5,691,267 A	11/1997	Nicolau et al.
4,422,903 A	12/1983	Messick et al.	5,762,765 A	6/1998	Berg
4,426,541 A	1/1984	King	5,767,307 A	6/1998	Ramprasad et al.
4,443,639 A	4/1984	Pesa et al.	5,770,770 A	6/1998	Kim et al.
4,448,644 A	5/1984	Foster et al.	5,800,681 A	9/1998	Berg
4,454,358 A	6/1984	Kummer et al.	5,821,111 A	10/1998	Gaddy et al.
4,465,854 A	8/1984	Pond et al.	5,849,657 A	12/1998	Rotgerink et al.
4,465,875 A	8/1984	Greenbank et al.	5,858,031 A	1/1999	Perlman
4,471,136 A	9/1984	Larkins et al.	5,861,530 A	1/1999	Atkins et al.
4,480,115 A	10/1984	McGinnis	5,945,570 A	8/1999	Arhancet et al.
4,492,808 A	1/1985	Hagen et al.	5,955,397 A	9/1999	Didillon et al.
4,497,967 A	2/1985	Wan	5,973,193 A	10/1999	Crane et al.
4,514,515 A	4/1985	Travers et al.	5,993,610 A	11/1999	Berg
4,517,391 A	5/1985	Schuster et al.	5,998,658 A	12/1999	Wu et al.
4,520,213 A	5/1985	Victor	6,040,474 A	3/2000	Jobson et al.
4,521,630 A	6/1985	Wattimena et al.	6,049,008 A	4/2000	Roberts et al.
4,541,897 A	9/1985	Sommer et al.	6,093,845 A	7/2000	Van Acker et al.
4,550,185 A	10/1985	Mabry et al.	6,114,571 A	9/2000	Abel et al.
4,559,109 A	12/1985	Lee et al.	6,121,498 A	9/2000	Tustin et al.
4,569,726 A	2/1986	Berg et al.	6,143,930 A	11/2000	Singh et al.
4,600,571 A	7/1986	McCarroll et al.	6,232,352 B1	5/2001	Vidalin et al.
4,613,700 A	9/1986	Maki et al.	6,232,504 B1	5/2001	Barteau et al.
4,626,321 A	12/1986	Grethlein et al.	6,294,703 B1	9/2001	Hara et al.
4,654,123 A	3/1987	Berg et al.	6,326,515 B1	12/2001	Clode et al.
4,678,543 A	7/1987	Houben et al.	6,375,807 B1	4/2002	Nieuwoudt et al.
4,692,218 A	9/1987	Houben et al.	6,462,231 B1	10/2002	Yanagawa et al.
4,761,505 A	8/1988	Diana et al.	6,472,555 B2	10/2002	Choudary et al.
4,774,365 A	9/1988	Chen et al.	6,486,366 B1	11/2002	Ostgard et al.
4,777,303 A	10/1988	Kitson et al.	6,495,730 B1	12/2002	Konishi et al.
4,804,791 A	2/1989	Kitson et al.	6,509,180 B1	1/2003	Verser et al.
4,826,795 A	5/1989	Kitson et al.	6,509,290 B1	1/2003	Vaughn et al.
4,842,693 A	6/1989	Wheldon	6,559,333 B1	5/2003	Brunelle et al.
4,880,937 A	11/1989	Matsushita et al.	6,603,038 B1	8/2003	Hagemeyer et al.
4,886,905 A	12/1989	Larkins et al.	6,627,770 B1	9/2003	Cheung et al.
4,902,823 A	2/1990	Wunder et al.	6,632,330 B1	10/2003	Colley et al.
4,943,354 A	7/1990	Osterburg et al.	6,657,078 B2	12/2003	Scates et al.
4,961,826 A	10/1990	Grethlein et al.	6,685,754 B2	2/2004	Kindig et al.
4,978,778 A	12/1990	Isshiki et al.	6,693,213 B1	2/2004	Kolena et al.
4,985,572 A	1/1991	Kitson et al.	6,696,596 B1	2/2004	Herzog et al.
4,990,655 A	2/1991	Kitson et al.	6,723,886 B2	4/2004	Allison et al.
4,994,608 A	2/1991	Torrence et al.	6,727,380 B2	4/2004	Ellis et al.
5,001,259 A	3/1991	Smith et al.	6,765,110 B2	7/2004	Warner et al.
5,004,845 A	4/1991	Bradley et al.	6,768,021 B2	7/2004	Horan et al.
5,008,235 A	4/1991	Wegman et al.	6,809,217 B1	10/2004	Colley et al.
5,026,908 A	6/1991	Smith et al.	6,812,372 B2	11/2004	Janssen et al.
5,035,776 A	7/1991	Knapp	6,852,877 B1	2/2005	Zeyss et al.
5,061,671 A	10/1991	Kitson et al.	6,903,045 B2	6/2005	Zoeller et al.
5,124,004 A	6/1992	Grethlein et al.	6,906,228 B2	6/2005	Fischer et al.
5,137,861 A	8/1992	Shih et al.	6,927,048 B2	8/2005	Verser et al.
5,144,068 A	9/1992	Smith et al.	7,005,541 B2	2/2006	Cheung et al.
5,149,680 A	9/1992	Kitson et al.	7,074,603 B2	7/2006	Verser et al.
5,155,084 A	10/1992	Horn et al.	7,084,312 B1	8/2006	Huber et al.
5,185,308 A	2/1993	Bartley et al.	7,115,772 B2	10/2006	Picard et al.
5,185,481 A	2/1993	Muto et al.	7,208,624 B2	4/2007	Scates et al.
5,215,902 A	6/1993	Tedder	7,297,236 B1	11/2007	Vander Griend et al.
5,233,099 A	8/1993	Tabata et al.	7,351,559 B2	4/2008	Verser et al.
5,237,108 A	8/1993	Marraccini et al.	7,361,794 B2	4/2008	Grosso
5,241,106 A	8/1993	Inoue et al.	7,375,049 B2	5/2008	Hayes et al.
5,243,095 A	9/1993	Roberts et al.	7,399,892 B2	7/2008	Rix et al.
5,250,271 A	10/1993	Horizoe et al.	7,425,657 B1	9/2008	Elliott et al.
5,284,983 A	2/1994	Muto et al.	7,507,562 B2	3/2009	Verser et al.
5,306,845 A	4/1994	Yokohama et al.	7,538,060 B2	5/2009	Barnicki et al.
5,348,625 A	9/1994	Berg	7,553,397 B1	6/2009	Colley et al.
5,350,504 A	9/1994	Dessau	7,572,353 B1	8/2009	Vander et al.
5,415,741 A	5/1995	Berg	7,594,981 B2	9/2009	Ikeda
5,426,246 A	6/1995	Nagahara et al.	7,608,744 B1	10/2009	Johnston et al.
5,437,770 A	8/1995	Berg	7,718,039 B2	5/2010	Dirkzwager et al.
5,445,716 A	8/1995	Berg	7,732,173 B2	6/2010	Mairal et al.
5,449,440 A	9/1995	Rescalli et al.	7,744,727 B2	6/2010	Blum et al.
5,476,827 A	12/1995	Ferrero et al.	7,790,938 B2	9/2010	Kawasaki et al.
5,488,185 A	1/1996	Ramachandran et al.	7,816,565 B2	10/2010	Johnston et al.
5,502,248 A	3/1996	Funk et al.	7,820,852 B2	10/2010	Johnston et al.
RE35,377 E	11/1996	Steinberg et al.	7,834,223 B2	11/2010	Atkins et al.
5,585,523 A	12/1996	Weiguny et al.	7,842,844 B2	11/2010	Atkins
			7,863,489 B2	1/2011	Johnston et al.
			7,884,253 B2	2/2011	Stites et al.
			7,888,082 B2	2/2011	Verser et al.
			7,947,746 B2	5/2011	Daniel et al.

(56)

References Cited

FOREIGN PATENT DOCUMENTS

U.S. PATENT DOCUMENTS

7,964,379 B2 6/2011 Verser et al.
 8,002,953 B2 8/2011 Lee et al.
 8,053,610 B2 11/2011 Kikuchi et al.
 8,071,389 B2 12/2011 Weck et al.
 8,071,821 B2 12/2011 Johnston et al.
 8,088,832 B2 1/2012 Melnichuk et al.
 8,128,826 B2 3/2012 Plante et al.
 8,129,436 B2 3/2012 Tirtowidjojo et al.
 8,198,057 B2 6/2012 Padgett
 8,232,440 B2 7/2012 Holtzapple et al.
 8,288,596 B2 10/2012 Garton et al.
 8,299,132 B2 10/2012 Gracey et al.
 8,299,133 B2 10/2012 Gracey et al.
 2003/0004057 A1 1/2003 Yamaguchi et al.
 2003/0013908 A1 1/2003 Horan et al.
 2003/0077771 A1 4/2003 Verser et al.
 2003/0104587 A1 6/2003 Verser et al.
 2003/0114719 A1 6/2003 Fischer et al.
 2004/0195084 A1 10/2004 Hetherington et al.
 2005/0003956 A1 1/2005 Fuglerud et al.
 2006/0019360 A1 1/2006 Verser et al.
 2006/0106246 A1 5/2006 Warner et al.
 2006/0127999 A1 6/2006 Verser et al.
 2007/0031954 A1 2/2007 Mairal et al.
 2007/0138083 A1 6/2007 Aizawa
 2007/0144886 A1 6/2007 Sylvester et al.
 2007/0238906 A1 10/2007 Brown et al.
 2007/0270511 A1 11/2007 Melnichuk et al.
 2008/0135396 A1 6/2008 Blum
 2008/0207953 A1 8/2008 Houssin et al.
 2008/0257784 A1 10/2008 Dath et al.
 2009/0005588 A1 1/2009 Hassan et al.
 2009/0014313 A1 1/2009 Lee et al.
 2009/0023192 A1 1/2009 Verser et al.
 2009/0069609 A1 3/2009 Kharas et al.
 2009/0081749 A1 3/2009 Verser et al.
 2009/0166172 A1 7/2009 Casey
 2009/0170963 A1 7/2009 Atkins
 2009/0221725 A1 9/2009 Chornet et al.
 2009/0318573 A1 12/2009 Stites et al.
 2009/0326080 A1 12/2009 Chornet et al.
 2010/0016454 A1 1/2010 Gracey et al.
 2010/0029980 A1 2/2010 Johnston et al.
 2010/0029993 A1 2/2010 Johnston et al.
 2010/0029995 A1 2/2010 Johnston et al.
 2010/0030001 A1 2/2010 Chen et al.
 2010/0030002 A1 2/2010 Johnston et al.
 2010/0041919 A1 2/2010 Wu et al.
 2010/0113843 A1 5/2010 Lee et al.
 2010/0121114 A1 5/2010 Johnston et al.
 2010/0125148 A1 5/2010 Johnston et al.
 2010/0137630 A1 6/2010 Garton et al.
 2010/0168493 A1 7/2010 Le Peltier et al.
 2010/0185021 A1 7/2010 Ross et al.
 2010/0196789 A1 8/2010 Fisher et al.
 2010/0197485 A1 8/2010 Johnston et al.
 2010/0197985 A1 8/2010 Johnston et al.
 2010/0249479 A1 9/2010 Berg-Slot et al.
 2010/0261800 A1 10/2010 Daniel et al.
 2010/0270139 A1 10/2010 Halvorsen et al.
 2011/0004033 A1 1/2011 Johnston et al.
 2011/0004034 A1 1/2011 Daniel et al.
 2011/0046421 A1 2/2011 Daniel et al.
 2011/0082322 A1 4/2011 Jevtic et al.
 2011/0190547 A1 8/2011 Jevtic et al.
 2011/0190548 A1 8/2011 Jevtic et al.
 2011/0224462 A1 9/2011 Ditzel et al.
 2011/0275861 A1 11/2011 Johnston et al.
 2011/0275862 A1 11/2011 Johnston et al.
 2012/0277491 A1 11/2012 Warner et al.
 2013/0035516 A1 2/2013 Orosco et al.

CN 102091429 6/2011
 CN 102228831 11/2011
 CN 102229520 11/2011
 CN 101525272 5/2012
 DE 2723611 11/1978
 EP 0104197 4/1984
 EP 0137749 4/1985
 EP 0167300 1/1986
 EP 0175558 3/1986
 EP 0192587 8/1986
 EP 0400904 5/1990
 EP 0372847 6/1990
 EP 0408528 7/1990
 EP 0456647 11/1991
 EP 2060553 5/2009
 EP 2072487 6/2009
 EP 2072488 6/2009
 EP 2072492 6/2009
 GB 1168785 10/1969
 GB 1559540 1/1980
 JP 60-25033 2/1985
 JP 4-193304 7/1992
 JP 6-116182 4/1994
 JP 10-306047 11/1998
 JP 2001-046874 2/2001
 JP 2001-157841 6/2001
 WO WO 83/03409 10/1983
 WO WO 2008/135192 11/2008
 WO WO 2009/009320 1/2009
 WO WO 2009/009322 1/2009
 WO WO 2009/009323 1/2009
 WO WO 2011/053365 5/2011

OTHER PUBLICATIONS

Pestman et al., Reactions of Carboxylic Acids on Oxides, *Journal of Catalysis* 168:255-264 (1997).
 Pestman et al., Identification of the Active Sites in the Selective Hydrogenation of Acetic Acid to Acetaldehyde on Iron Oxide Catalysts, *Journal of Catalysis* 174:142-152 (1998).
 Pallasana et al., Reaction Paths in the Hydrogenolysis of Acetic Acid to Ethanol over Pd(111), Re(0001), and RdRe Alloys, *Journal of Catalysis* 209, 289-305 Mar. 1, 2002.
 Ordóñez et al., The role of metal and support sites on the hydrogenation of acetic acid on Ru-based catalysts, 21st NAM San Francisco, CA, Jun. 10, 2009.
 International Written Opinion mailed May 15, 2012 in corresponding International Application No. PCT/US2011/023308.
 International Search Report mailed Aug. 5, 2011 in corresponding International Application No. PCT/US2011/023308.
 International Preliminary Report on Patentability mailed Jul. 6, 2012 in corresponding International Application No. PCT/US2011/023308.
 Hilmen, Separation of Azeotropic Mixtures: Tools for Analysis and Studies on Batch Distillation Operation (Nov. 2000) p. 17-20.
 Gursahani et al., Reaction kinetics measurements and analysis of reaction pathways for conversions of acetic acid, ethanol, and ethyl acetate over silica-supported Pt, *Applied Catalysis A: General* 222 (2001) 369-392.
 Amit M. Goda et al., DFT modeling of selective reduction of acetic acid to acetaldehyde on Pt-based bimetallic catalysts, 20th NAM, Houston, TX, Jun. 17-22, 2007 available online at < <http://www.nacatsoc.org/20nam/abstracts/O-S9-18.pdf>>.
 Alcalá, et al., (2005). Experimental and DFT studies of the conversion of ethanol and acetic acid on PtSn-based catalysts, *Journal of Physical Chemistry*, 109(6), 2074-2085.
 Proc. Roy Soc. A314, pp. 473-498 (1970).
 Brunauer Emmett and Teller, *J. Am. Chem. Soc.* 60, 309 (1938).

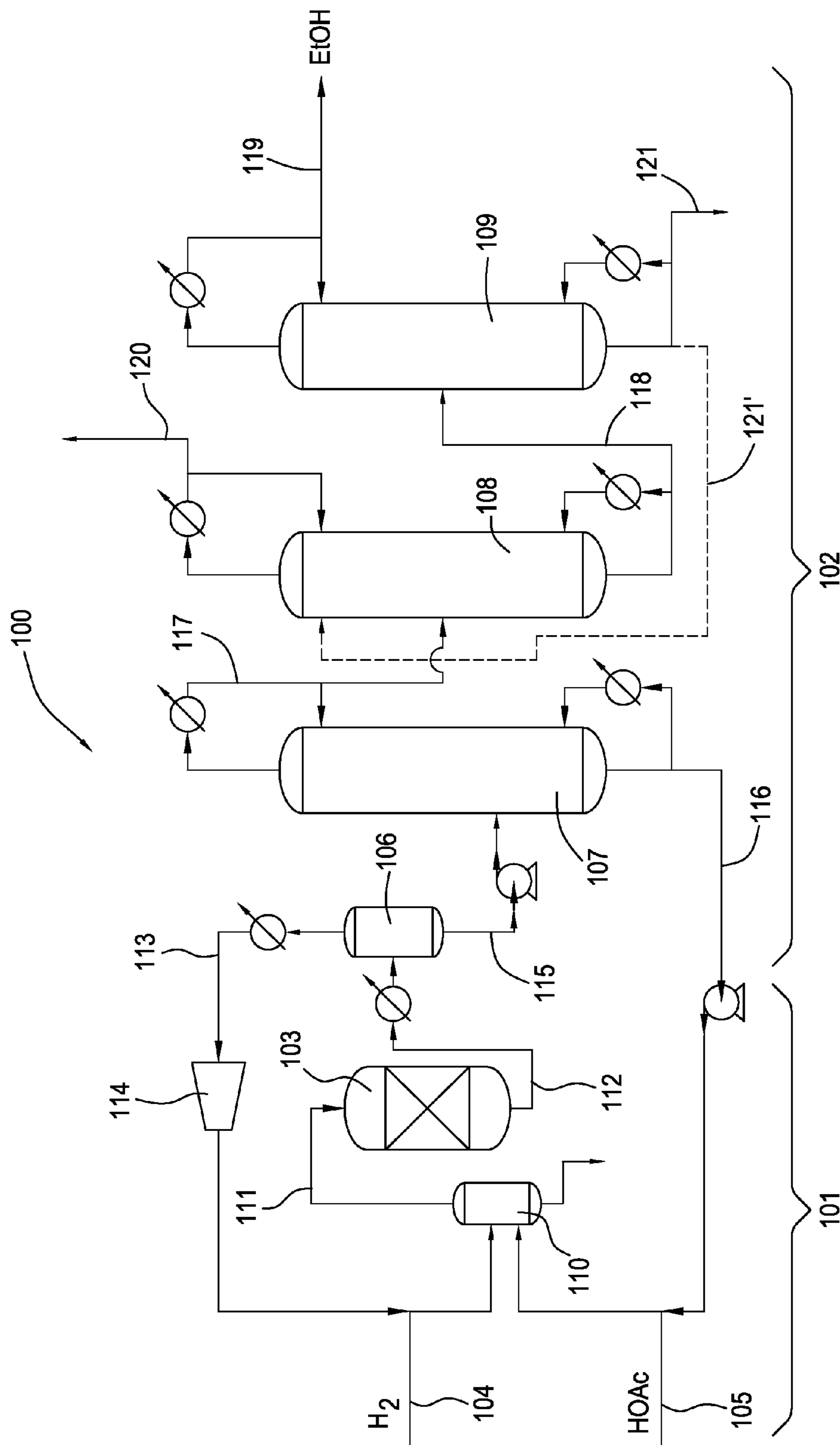

FIG. 1

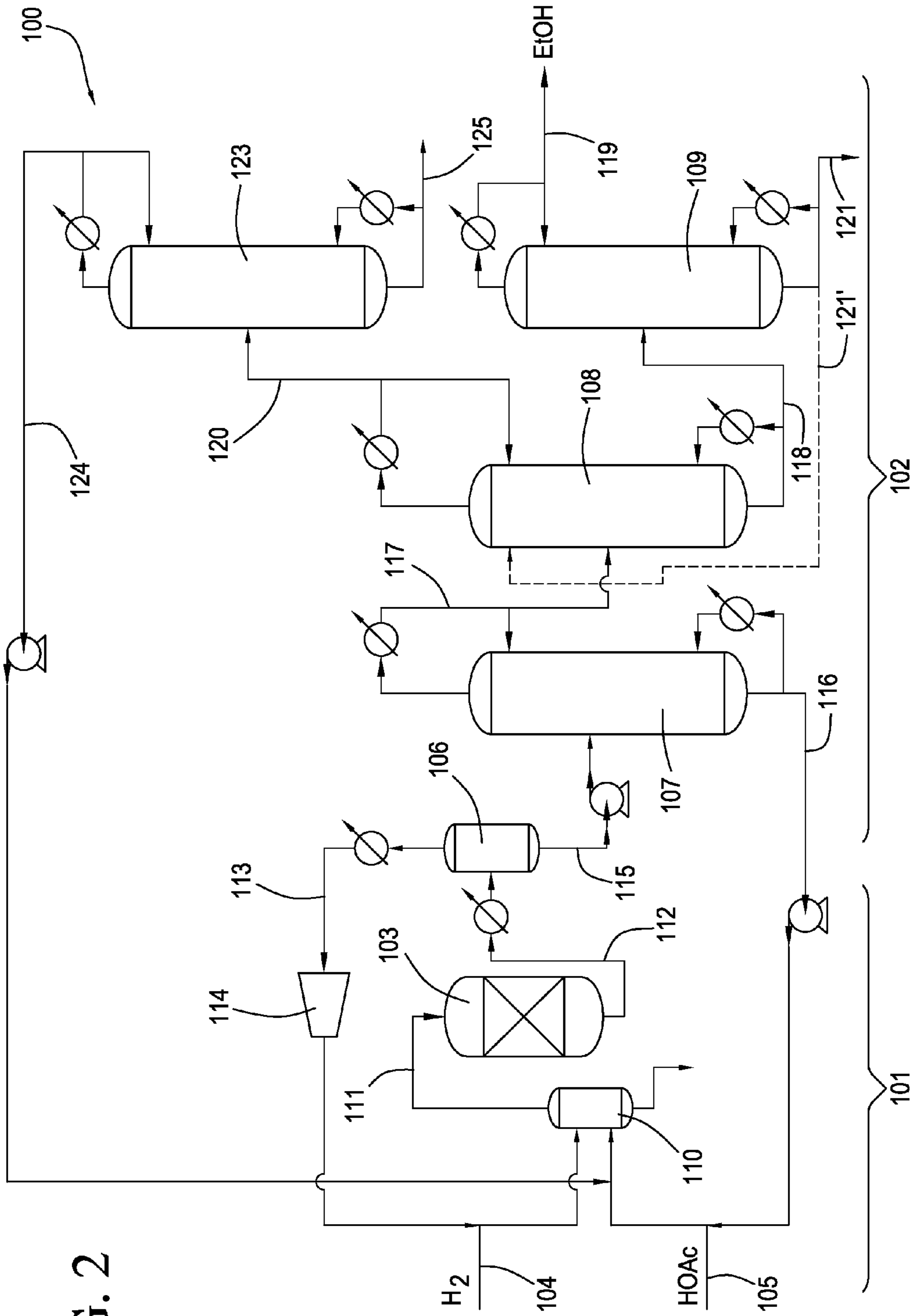

FIG. 2

**PROCESS FOR UTILIZING A WATER
STREAM IN A HYDROLYSIS REACTION TO
FORM ETHANOL**

CROSS REFERENCE TO RELATED
APPLICATIONS

This application is a continuation of U.S. application Ser. No. 13/542,309, filed Jul. 5, 2012, which is a continuation of U.S. application Ser. No. 12/852,297, filed Aug. 6, 2010, which issued as U.S. Pat. No. 8,222,466 and which claims priority to U.S. Provisional Application No. 61/300,815, filed on Feb. 2, 2010, U.S. Provisional Application No. 61/332,696, filed on May 7, 2010; U.S. Provisional Application No. 61/332,699, filed on May 7, 2010, U.S. Provisional Application No. 61/332,728, filed on May 7, 2010, and U.S. Provisional Application No. 61/346,344, filed on May 19, 2010, the entireties of which are incorporated herein by reference.

FIELD OF THE INVENTION

The present invention relates generally to processes for producing a water stream from ethanol production and, in particular, to processes for producing a water stream that is essentially free of organic impurities from a crude ethanol product.

BACKGROUND OF THE INVENTION

Ethanol for industrial use is conventionally produced from petrochemical feed stocks, such as oil, natural gas, or coal; from feed stock intermediates, such as syngas; or from starchy materials or cellulose materials, such as corn and sugar cane. Conventional methods for producing ethanol from petrochemical feed stocks, as well as from cellulose materials, include the acid-catalyzed hydration of ethylene, methanol homologation, direct alcohol synthesis, and Fischer-Tropsch synthesis. Instability in petrochemical feed stock prices contributes to fluctuations in the cost of conventionally produced ethanol, making the need for alternative sources of ethanol production all the greater when feed stock prices rise. Starchy materials, as well as cellulose material, are often converted to ethanol by fermentation. However, fermentation is typically used for consumer production of ethanol. In addition, fermentation of starchy or cellulose materials competes with food sources and places restraints on the amount of ethanol that can be produced for industrial use.

Ethanol production via the reduction of alkanolic acids and/or other carbonyl group-containing compounds has been widely studied, and a variety of combinations of catalysts, supports, and operating conditions have been mentioned in the literature. During the reduction of alkanolic acid, e.g., acetic acid, other compounds are formed with ethanol or are formed in side reactions. In addition, water may be formed in an equal molar ratio with ethanol during the hydrogenation of acetic acid. These impurities limit the production and recovery of ethanol from such reaction mixtures. In addition, the impurities may be present in one or more purge streams. When impurities are present in water purge streams, the water purge stream must be treated, either chemically or biologically, to remove the impurities before the purge stream may be disposed. The further treatment adds costs and decreases the overall efficiency of producing ethanol.

Therefore, a need remains for an ethanol production process wherein the separation portion of the process produces a purified water stream that, as formed, contains little, if any,

impurities. This water stream would not require further processing in order to be subsequently used or responsibly disposed.

SUMMARY OF THE INVENTION

In one embodiment, the invention is to a process for producing a water stream. The process comprises the step of hydrogenating an acetic acid feed stream to form a crude ethanol product. The crude ethanol product preferably comprises ethanol, water, ethyl acetate, and acetic acid. The process further comprises the step of separating at least a portion of the crude ethanol product in at least one column of a plurality of columns into a distillate comprising ethanol and a residue comprising the water stream.

In another embodiment, the invention is to a process for producing a water stream. The process comprises the step of providing a crude ethanol product comprising ethanol, water, ethyl acetate, and acetic acid. The process further comprises the step of separating at least a portion of the crude ethanol product in at least one column of a plurality of columns into a distillate comprising ethanol and a residue comprising the water stream.

The separating step, in some embodiments, further comprises the steps of separating at least a portion of the crude ethanol product in a first column of the plurality of columns into a first distillate comprising ethanol, water and ethyl acetate, and a first residue comprising acetic acid; separating at least a portion of the first distillate in a second column of the plurality of columns into a second distillate comprising ethyl acetate and a second residue comprising ethanol and water; and separating at least a portion of the second residue in a third column of the plurality of columns into a third distillate comprising ethanol and a third residue comprising the water stream.

In preferred embodiments, the at least one column has a base temperature ranging from 70 to 110° C. In other embodiment, the base temperature of the at least one column is at least 102° C.

Preferably, the resultant water stream is essentially free of organic impurities other than acetic acid and ethanol. In one embodiment, the resultant water stream comprises at least 97 wt. % water; less than 0.5 wt. % acetic acid; less than 0.005 wt. % ethanol; and less than 0.001 wt. % ethyl acetate. In other embodiments, the water stream water stream has a pH ranging from 2.99 to 3.35.

In one embodiment, the process comprises the step of hydrogenating acetic acid in a reactor in the presence of a catalyst to form a crude ethanol product. The crude ethanol product may comprise ethanol, water, ethyl acetate, and/or acetic acid. The process may further comprise the step of separating at least a portion of the crude ethanol product, optionally in a first column, into a first distillate and a first residue. The first distillate may comprise ethanol, water and ethyl acetate and the first residue may comprise acetic acid. The process may further comprise the step of separating at least a portion of the first distillate, optionally in a second column, into a second distillate and a second residue. The second distillate may comprise ethyl acetate and the second residue may comprise ethanol and water. The process may further comprise the step of separating at least a portion of the second residue, optionally in a third column, into a third distillate and a third residue. The third distillate may comprise ethanol and the third residue may comprise at least 97 wt. % water; less than 0.5 wt. % acetic acid; less than 0.005 wt. % ethanol; and less than 0.001 wt. % ethyl acetate. The process

3

may further comprise the step of hydrolyzing at least a portion of the second distillate with at least a portion of the third residue.

In one embodiment, the invention relates to process for producing a water stream. The process comprises the step of providing the crude ethanol product comprising ethanol, water, acetic acid, and ethyl acetate, e.g., hydrogenating a feed stream comprising acetic acid to form a crude ethanol product comprising ethanol, water, ethyl acetate, and acetic acid. The process may further comprise the step of separating at least a portion of the crude ethanol product to form at least one ethanol stream and a water stream. The at least one ethanol stream may comprise ethanol and ethyl acetate and the water stream may comprise at least 97 wt. % water; less than 0.5 wt. % acetic acid; less than 0.005 wt. % ethanol; and less than 0.001 wt. % ethyl acetate. The process may further comprise the step of hydrolyzing at least a portion of the ethyl acetate in the at least one ethanol stream with at least a portion of the water stream to form a hydrolyzed stream comprising ethanol.

BRIEF DESCRIPTION OF DRAWINGS

The invention is described in detail below with reference to the appended drawings, wherein like numerals designate similar parts.

FIG. 1 is a schematic diagram of a hydrogenation system for ethanol production in accordance with one embodiment of the present invention.

FIG. 2 is a schematic diagram of a hydrogenation system for ethanol production in accordance with one embodiment of the present invention.

DETAILED DESCRIPTION OF THE INVENTION

The present invention generally relates to the separation of a crude ethanol product to form a water stream that is essentially free of organic impurities other than acetic acid and ethanol. For purposes of the present invention organic impurities may include ethyl acetate, acetaldehyde, acetone, acetal, and mixtures thereof. In one embodiment, the amount of organic impurities other than acetic acid and ethanol may be less than 10 wppm, e.g., less than 5 wppm or less than 1 wppm.

The crude ethanol product is preferably formed via the hydrogenation of acetic acid in an acetic acid feed stream. The hydrogenation is preferably performed in the presence of a catalyst. The hydrogenation of acetic acid to form ethanol and water may be represented by the following reaction:

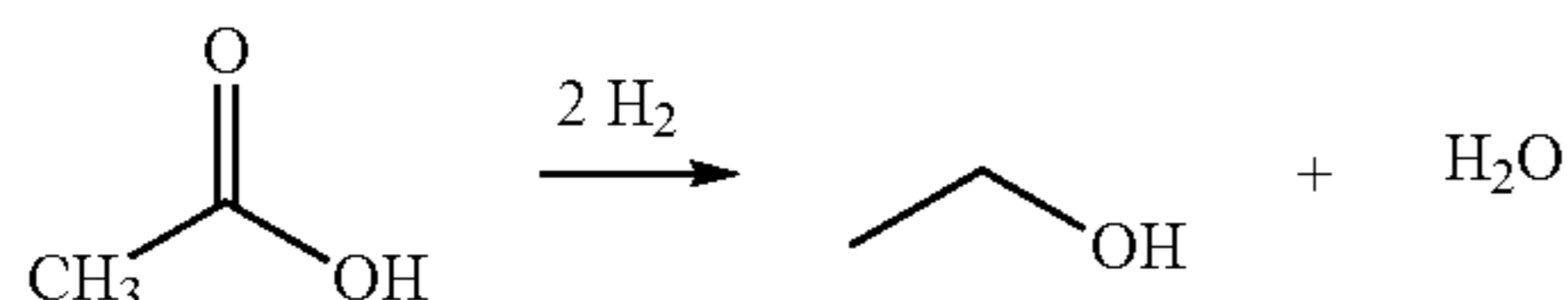

In theoretical embodiments where ethanol and water are the only products of the hydrogenation reaction, the crude ethanol product comprises 71.9 wt. % ethanol and 28.1 wt. % water. However, not all of the acetic acid fed to the hydrogenation reactor is typically converted to ethanol. Subsequent reactions of ethanol, such as esterification, may form other byproducts such as ethyl acetate. Crude ethanol products are described in Tables 1 and 2, below.

The present invention, in one embodiment, relates to processes for producing a water stream from a crude ethanol mixture that comprises the impurities discussed above. In one

4

embodiment, the crude ethanol product may be separated using at least one, e.g., at least two or at least three, column(s) of a plurality of columns. Preferably, the crude ethanol product or a derivative stream thereof is fed to a distillation column, which yields a distillate comprising ethanol and a residue comprising the water stream.

As one example, the water stream comprises at least 97 wt. % water, e.g., at least 98 wt. % or at least 99 wt. %. The water stream may further comprise less than 0.5 wt. % acetic acid, e.g., less than 0.1 wt. % or less than 0.05 wt. %. The water stream may also comprise less than 0.005 wt. % ethanol, e.g., less than 0.002 wt. % or less than 0.001 wt. %. Preferably, the water stream has a pH ranging from 2.99 to 3.35, e.g., from 3.05 to 3.29 or from 3.10 to 3.23.

1. Hydrogenation Process

Suitable hydrogenation catalysts include catalysts comprising a first metal and optionally one or more of a second metal, a third metal or additional metals, optionally on a catalyst support. The first and optional second and third metals may be selected from Group IB, IIB, IIIB, IVB, VB, VIB, VIIB, VIII transitional metals, a lanthanide metal, an actinide metal or a metal selected from any of Groups IIIA, IVA, VA, and VIA. Preferred metal combinations for some exemplary catalyst compositions include platinum/tin, platinum/ruthenium, platinum/rhenium, palladium/ruthenium, palladium/rhenium, cobalt/palladium, cobalt/platinum, cobalt/chromium, cobalt/ruthenium, silver/palladium, copper/palladium, nickel/palladium, gold/palladium, ruthenium/rhenium, and ruthenium/iron. Exemplary catalysts are further described in U.S. Pat. No. 7,608,744 and US Publication No. 2010/0029995, the entireties of which are incorporated herein by reference. Additional catalysts are described in US Pub. No. 2010/0197485, filed on Feb. 2, 2010, the entirety of which is incorporated herein by reference.

In one exemplary embodiment, the catalyst comprises a first metal selected from the group consisting of copper, iron, cobalt, nickel, ruthenium, rhodium, palladium, osmium, iridium, platinum, titanium, zinc, chromium, rhenium, molybdenum, and tungsten. Preferably, the first metal is selected from the group consisting of platinum, palladium, cobalt, nickel, and ruthenium. More preferably, the first metal is selected from platinum and palladium. When the first metal comprises platinum, it is preferred that the catalyst comprises platinum in an amount less than 5 wt. %, e.g., less than 3 wt. % or less than 1 wt. %, due to the high demand for platinum.

As indicated above, the catalyst optionally further comprises a second metal, which typically would function as a promoter. If present, the second metal preferably is selected from the group consisting of copper, molybdenum, tin, chromium, iron, cobalt, vanadium, tungsten, palladium, platinum, lanthanum, cerium, manganese, ruthenium, rhenium, gold, and nickel. More preferably, the second metal is selected from the group consisting of copper, tin, cobalt, rhenium, and nickel. More preferably, the second metal is selected from tin and rhenium.

If the catalyst includes two or more metals, e.g., a first metal and a second metal, the first metal optionally is present in the catalyst in an amount from 0.1 to 10 wt. %, e.g., from 0.1 to 5 wt. %, or from 0.1 to 3 wt. %. The second metal preferably is present in an amount from 0.1 and 20 wt. %, e.g., from 0.1 to 10 wt. %, or from 0.1 to 5 wt. %. For catalysts comprising two or more metals, the two or more metals may be alloyed with one another or may comprise a non-alloyed metal solution or mixture.

The preferred metal ratios may vary depending on the metals used in the catalyst. In some exemplary embodiments, the mole ratio of the first metal to the second metal is from

5

10:1 to 1:10, e.g., from 4:1 to 1:4, from 2:1 to 1:2, from 1.5:1 to 1:1.5 or from 1.1:1 to 1:1.1.

The catalyst may also comprise a third metal selected from any of the metals listed above in connection with the first or second metal, so long as the third metal is different from the first and second metals. In preferred aspects, the third metal is selected from the group consisting of cobalt, palladium, ruthenium, copper, zinc, platinum, tin, and rhenium. More preferably, the third metal is selected from cobalt, palladium, and ruthenium. When present, the total weight of the third metal preferably is from 0.05 and 4 wt. %, e.g., from 0.1 to 3 wt. %, or from 0.1 to 2 wt. %.

In addition to one or more metals, the exemplary catalysts further comprise a support or a modified support, meaning a support that includes a support material and a support modifier, which adjusts the acidity of the support material. The total weight of the support or modified support, based on the total weight of the catalyst, preferably is from 75 wt. % to 99.9 wt. %, e.g., from 78 wt. % to 97 wt. %, or from 80 wt. % to 95 wt. %. In preferred embodiments that use a modified support, the support modifier is present in an amount from 0.1 wt. % to 50 wt. %, e.g., from 0.2 wt. % to 25 wt. %, from 0.5 wt. % to 15 wt. %, or from 1 wt. % to 8 wt. %, based on the total weight of the catalyst.

Suitable support materials may include, for example, stable metal oxide-based supports or ceramic-based supports. Preferred supports include siliceous supports, such as silica, silica/alumina, a Group IIA silicate such as calcium metasilicate, pyrogenic silica, high purity silica, and mixtures thereof. Other supports may include, but are not limited to, iron oxide, alumina, titania, zirconia, magnesium oxide, carbon, graphite, high surface area graphitized carbon, activated carbons, and mixtures thereof.

In the production of ethanol, the catalyst support may be modified with a support modifier. Preferably, the support modifier is a basic modifier that has a low volatility or no volatility. Such basic modifiers, for example, may be selected from the group consisting of: (i) alkaline earth oxides, (ii) alkali metal oxides, (iii) alkaline earth metal metasilicates, (iv) alkali metal metasilicates, (v) Group IIB metal oxides, (vi) Group IIB metal metasilicates, (vii) Group IIIB metal oxides, (viii) Group IIIB metal metasilicates, and mixtures thereof. In addition to oxides and metasilicates, other types of modifiers including nitrates, nitrites, acetates, and lactates may be used. Preferably, the support modifier is selected from the group consisting of oxides and metasilicates of any of sodium, potassium, magnesium, calcium, scandium, yttrium, and zinc, as well as mixtures of any of the foregoing. Preferably, the support modifier is a calcium silicate, and more preferably calcium metasilicate (CaSiO_3). If the support modifier comprises calcium metasilicate, it is preferred that at least a portion of the calcium metasilicate is in crystalline form.

A preferred silica support material is SS61138 High Surface Area (HSA) Silica Catalyst Carrier from Saint Gobain NorPro. The Saint-Gobain NorPro SS61138 silica contains approximately 95 wt. % high surface area silica; a surface area of about $250 \text{ m}^2/\text{g}$; a median pore diameter of about 12 nm; an average pore volume of about $1.0 \text{ cm}^3/\text{g}$ as measured by mercury intrusion porosimetry and a packing density of about $0.352 \text{ g}/\text{cm}^3$ ($22 \text{ lb}/\text{ft}^3$).

A preferred silica/alumina support material is KA-160 (Sud Chemie) silica spheres having a nominal diameter of about 5 mm, a density of about $0.562 \text{ g}/\text{ml}$, in absorptivity of about $0.583 \text{ g H}_2\text{O}/\text{g support}$, a surface area of about 160 to $175 \text{ m}^2/\text{g}$, and a pore volume of about $0.68 \text{ ml}/\text{g}$.

6

As will be appreciated by those of ordinary skill in the art, support materials are selected such that the catalyst system is suitably active, selective and robust under the process conditions employed for the formation of ethanol.

The metals of the catalysts may be dispersed throughout the support, coated on the outer surface of the support (egg shell) or decorated on the surface of the support.

The catalyst compositions suitable for use with the present invention preferably are formed through metal impregnation of the modified support, although other processes such as chemical vapor deposition may also be employed. Such impregnation techniques are described in U.S. Pat. No. 7,608,744, US Publication Nos. 2010/0029995, and 2010/0197485, referred to above, the entireties of which are incorporated herein by reference.

Some embodiments of the process of hydrogenating acetic acid to form ethanol according to one embodiment of the invention may include a variety of configurations using a fixed bed reactor or a fluidized bed reactor, as one of skill in the art will readily appreciate. In many embodiments of the present invention, an "adiabatic" reactor can be used; that is, there is little or no need for internal plumbing through the reaction zone to add or remove heat. In other embodiments, radial flow reactor or reactors may be employed, or a series of reactors may be employed with or without heat exchange, quenching, or introduction of additional feed material. Alternatively, a shell and tube reactor provided with a heat transfer medium may be used. In many cases, the reaction zone may be housed in a single vessel or in a series of vessels with heat exchangers therebetween.

In preferred embodiments, the catalyst is employed in a fixed bed reactor, e.g., in the shape of a pipe or tube, where the reactants, typically in the vapor form, are passed over or through the catalyst. Other reactors, such as fluid or ebullient bed reactors, can be employed. In some instances, the hydrogenation catalysts may be used in conjunction with an inert material to regulate the pressure drop of the reactant stream through the catalyst bed and the contact time of the reactant compounds with the catalyst particles.

The hydrogenation reaction may be carried out in either the liquid phase or vapor phase. Preferably, the reaction is carried out in the vapor phase under the following conditions. The reaction temperature may range from 125°C . to 350°C ., e.g., from 200°C . to 325°C ., from 225°C . to 300°C ., or from 250°C . to 300°C . The pressure may range from 10 KPa to 3000 KPa (about 1.5 to 435 psi), e.g., from 50 KPa to 2300 KPa, or from 100 KPa to 1500 KPa. The reactants may be fed to the reactor at a gas hourly space velocity (GHSV) of greater than 500 hr^{-1} , e.g., greater than 1000 hr^{-1} , greater than 2500 or even greater than 5000 hr^{-1} . In terms of ranges the GHSV may range from 50 hr^{-1} to $50,000 \text{ hr}^{-1}$, e.g., from 500 hr^{-1} to $30,000 \text{ hr}^{-1}$, from 1000 hr^{-1} to $10,000 \text{ hr}^{-1}$, or from 1000 hr^{-1} to 6500 hr^{-1} .

The hydrogenation optionally is carried out at a pressure just sufficient to overcome the pressure drop across the catalytic bed at the GHSV selected, although there is no bar to the use of higher pressures, it being understood that considerable pressure drop through the reactor bed may be experienced at high space velocities, e.g., 5000 hr^{-1} or $6,500 \text{ hr}^{-1}$.

Although the reaction consumes two moles of hydrogen per mole of acetic acid to produce one mole of ethanol, the actual molar ratio of hydrogen to acetic acid in the feed stream may vary from about 100:1 to 1:100, e.g., from 50:1 to 1:50, from 20:1 to 1:2, or from 12:1 to 1:1. Most preferably, the molar ratio of hydrogen to acetic acid is greater than 2:1, e.g., greater than 4:1 or greater than 8:1.

Contact or residence time can also vary widely, depending upon such variables as amount of acetic acid, catalyst, reactor, temperature and pressure. Typical contact times range from a fraction of a second to more than several hours when a catalyst system other than a fixed bed is used, with preferred contact times, at least for vapor phase reactions, of from 0.1 to 100 seconds, e.g., from 0.3 to 80 seconds or from 0.4 to 30 seconds.

The raw materials, acetic acid and hydrogen, used in connection with the process of this invention may be derived from any suitable source including natural gas, petroleum, coal, biomass, and so forth. As examples, acetic acid may be produced via methanol carbonylation, acetaldehyde oxidation, ethylene oxidation, oxidative fermentation, and anaerobic fermentation. As petroleum and natural gas prices fluctuate becoming either more or less expensive, methods for producing acetic acid and intermediates such as methanol and carbon monoxide from alternate carbon sources have drawn increasing interest. In particular, when petroleum is relatively expensive compared to natural gas, it may become advantageous to produce acetic acid from synthesis gas ("syn gas") that is derived from any available carbon source. U.S. Pat. No. 6,232,352, the disclosure of which is incorporated herein by reference, for example, teaches a method of retrofitting a methanol plant for the manufacture of acetic acid. By retrofitting a methanol plant, the large capital costs associated with CO generation for a new acetic acid plant are significantly reduced or largely eliminated. All or part of the syn gas is diverted from the methanol synthesis loop and supplied to a separator unit to recover CO and hydrogen, which are then used to produce acetic acid. In addition to acetic acid, such a process can also be used to make hydrogen which may be utilized in connection with this invention.

Methanol carbonylation processes suitable for production of acetic acid are described in U.S. Pat. Nos. 7,208,624, 7,115,772, 7,005,541, 6,657,078, 6,627,770, 6,143,930, 5,599,976, 5,144,068, 5,026,908, 5,001,259, and 4,994,608, the disclosure of which are incorporated herein by reference in their entireties. Optionally, the production of ethanol may be integrated with such methanol carbonylation processes.

U.S. Pat. No. RE 35,377 also incorporated herein by reference in its entirety, provides a method for the production of methanol by conversion of carbonaceous materials such as oil, coal, natural gas and biomass materials. The process includes hydrogasification of solid and/or liquid carbonaceous materials to obtain a process gas which is steam pyrolyzed with additional natural gas to form synthesis gas. The syn gas is converted to methanol which may be carbonylated to acetic acid. The method likewise produces hydrogen which may be used in connection with this invention as noted above. U.S. Pat. No. 5,821,111, which discloses a process for converting waste biomass through gasification into synthesis gas as well as U.S. Pat. No. 6,685,754, the disclosures of which are incorporated herein by reference in their entireties.

In one optional embodiment, the acetic acid fed to the hydrogenation reaction may also comprise other carboxylic acids and anhydrides, as well as acetaldehyde and acetone. Preferably, a suitable acetic acid feed stream comprises one or more of the compounds selected from the group consisting of acetic acid, acetic anhydride, acetaldehyde, and mixtures thereof. These other compounds may also be hydrogenated in the processes of the present invention. In some embodiments, the present of carboxylic acids, such as propanoic acid or its anhydride, may be beneficial in producing propanol.

Alternatively, acetic acid in vapor form may be taken directly as crude product from the flash vessel of a methanol carbonylation unit of the class described in U.S. Pat. No.

6,657,078, the entirety of which is incorporated herein by reference. The crude vapor product, for example, may be fed directly to the ethanol synthesis reaction zones of the present invention without the need for condensing the acetic acid and light ends or removing water, saving overall processing costs.

The acetic acid may be vaporized at the reaction temperature, following which the vaporized acetic acid can be fed along with hydrogen in an undiluted state or diluted with a relatively inert carrier gas, such as nitrogen, argon, helium, carbon dioxide and the like. For reactions run in the vapor phase, the temperature should be controlled in the system such that it does not fall below the dew point of acetic acid. In one embodiment the acetic acid may be vaporized at the boiling point of acetic acid at the particular pressure, and then the vaporized acetic acid may be further heated to the reactor inlet temperature. In another embodiment, the acetic acid is transferred to the vapor state by passing hydrogen, recycle gas, another suitable gas, or mixtures thereof through the acetic acid at a temperature below the boiling point of acetic acid, thereby humidifying the carrier gas with acetic acid vapors, followed by heating the mixed vapors up to the reactor inlet temperature. Preferably, the acetic acid is transferred to the vapor by passing hydrogen and/or recycle gas through the acetic acid at a temperature at or below 125° C., followed by heating of the combined gaseous stream to the reactor inlet temperature.

In particular, the hydrogenation of acetic acid may achieve favorable conversion of acetic acid and favorable selectivity and productivity to ethanol. For purposes of the present invention, the term "conversion" refers to the amount of acetic acid in the feed that is converted to a compound other than acetic acid. Conversion is expressed as a mole percentage based on acetic acid in the feed. The conversion may be at least 10%, e.g., at least 20%, at least 40%, at least 50%, at least 60%, at least 70% or at least 80%. Although catalysts that have high conversions are desirable, such as at least 80% or at least 90%, in some embodiments a low conversion may be acceptable at high selectivity for ethanol. It is, of course, well understood that in many cases, it is possible to compensate for conversion by appropriate recycle streams or use of larger reactors, but it is more difficult to compensate for poor selectivity.

Selectivity is expressed as a mole percent based on converted acetic acid. It should be understood that each compound converted from acetic acid has an independent selectivity and that selectivity is independent from conversion. For example, if 50 mole % of the converted acetic acid is converted to ethanol, we refer to the ethanol selectivity as 50%. Preferably, the catalyst selectivity to ethoxylates is at least 60%, e.g., at least 70%, or at least 80%. As used herein, the term "ethoxylates" refers specifically to the compounds ethanol, acetaldehyde, and ethyl acetate. Preferably, the selectivity to ethanol is at least 80%, e.g., at least 85% or at least 88%. Preferred embodiments of the hydrogenation process also have low selectivity to undesirable products, such as methane, ethane, and carbon dioxide. The selectivity to these undesirable products preferably is less than 4%, e.g., less than 2% or less than 1%. More preferably, these undesirable products are not detectable. Formation of alkanes may be low, and ideally less than 2%, less than 1%, or less than 0.5% of the acetic acid passed over the catalyst is converted to alkanes, which have little value other than as fuel.

The term "productivity," as used herein, refers to the grams of a specified product, e.g., ethanol, formed during the hydrogenation based on the kilograms of catalyst used per hour. A productivity of at least 200 grams of ethanol per kilogram catalyst per hour, e.g., at least 400 grams of ethanol per kilogram catalyst per hour or at least 600 grams of ethanol per

kilogram catalyst per hour, is preferred. In terms of ranges, the productivity preferably is from 200 to 3,000 grams of ethanol per kilogram catalyst per hour, e.g., from 400 to 2,500 per kilogram catalyst per hour or from 600 to 2,000 per kilogram catalyst per hour.

In various embodiments, the crude ethanol product produced by the hydrogenation process, before any subsequent processing, such as purification and separation, will typically comprise unreacted acetic acid, ethanol, and water. As used herein, the term "crude ethanol product" refers to any composition comprising from 5 to 70 wt. % ethanol and from 5 to 35 wt. % water. In some exemplary embodiments, the crude ethanol product comprises ethanol in an amount from 5 wt. % to 70 wt. %, e.g., from 10 wt. % to 60 wt. %, or from 15 wt. % to 50 wt. %, based on the total weight of the crude ethanol product. Preferably, the crude ethanol product contains at least 10 wt. % ethanol, at least 15 wt. % ethanol or at least 20 wt. % ethanol. The crude ethanol product typically may further comprise unreacted acetic acid, depending on conversion, for example, in an amount of less than 90 wt. %, e.g., less than 80 wt. % or less than 70 wt. %. In terms of ranges, the unreacted acetic acid is preferably from 0 to 90 wt. %, e.g., from 5 to 80 wt. %, from 15 to 70 wt. %, from 20 to 70 wt. % or from 25 to 65 wt. %. As water is formed in the reaction process, water will generally be present in the crude ethanol product, for example, in amounts ranging from 5 to 35 wt. %, e.g., from 10 to 30 wt. % or from 10 to 26 wt. %. Ethyl acetate may also be produced during the hydrogenation of acetic acid or through side reactions and may be present, for example, in amounts ranging from 0 to 20 wt. %, e.g., from 0 to 15 wt. %, from 1 to 12 wt. % or from 3 to 10 wt. %. Acetaldehyde may also be produced through side reactions and may be present, for example, in amounts ranging from 0 to 10 wt. %, e.g., from 0 to 3 wt. %, from 0.1 to 3 wt. % or from 0.2 to 2 wt. %. Other components, such as, for example, esters, ethers, aldehydes, ketones, alkanes, and carbon dioxide, if detectable, collectively may be present in amounts less than 10 wt. %, e.g., less than 6 wt. % or less than 4 wt. %. In terms of ranges, other components may be present in an amount from 0.1 to 10 wt. %, e.g., from 0.1 to 6 wt. %, or from 0.1 to 4 wt. %. Exemplary embodiments of crude ethanol compositional ranges are provided in Table 1.

TABLE 1

CRUDE ETHANOL PRODUCT COMPOSITIONS				
Component	Conc. (wt. %)	Conc. (wt. %)	Conc. (wt. %)	Conc. (wt. %)
Ethanol	5 to 70	10 to 60	15 to 50	25 to 50
Acetic Acid	0 to 90	5 to 80	15 to 70	20 to 70
Water	5 to 35	5 to 30	10 to 30	10 to 26
Ethyl Acetate	0 to 20	0 to 15	1 to 12	3 to 10
Acetaldehyde	0 to 10	0 to 3	0.1 to 3	0.2 to 2
Others	0.1 to 10	0.1 to 6	0.1 to 4	—

2. Separation of Crude Ethanol Product

FIGS. 1 and 2 show hydrogenation systems 100 suitable for the hydrogenation of acetic acid and the separation of ethanol from the crude reaction mixture according to some embodiments of the invention. In FIG. 1, system 100 comprises reaction zone 101 and distillation zone 102. Reaction zone 101 comprises reactor 103, hydrogen feed line 104 and acetic acid feed line 105. Distillation zone 102 comprises flasher 106, first column 107, second column 108, and third column 109. FIG. 2 further comprises a fourth column 123 in distillation zone 102 for further the overheads from the second column 108.

In FIGS. 1 and 2, hydrogen and acetic acid are fed to a vaporizer 110 via lines 104 and 105, respectively, to create a vapor feed stream in line 111 that is directed to reactor 103. In one embodiment (not shown), lines 104 and 105 may be combined and jointly fed to the vaporizer 110, e.g., in one stream containing both hydrogen and acetic acid. The temperature of the vapor feed stream in line 111 is preferably from 100° C. to 350° C., e.g., from 120° C. to 310° C. or from 150° C. to 300° C. Any feed that is not vaporized is removed from vaporizer 110, as shown in FIG. 1, and may be recycled thereto. In addition, although FIG. 1 shows line 111 being directed to the top of reactor 103, line 111 may, be directed to the side, upper portion, or bottom of reactor 103. Further modifications and additional components to reaction zone 101 are described below.

Reactor 103 contains the catalyst that is used in the hydrogenation of the acetic acid. In one embodiment, one or more guard beds (not shown) may be used to protect the catalyst from poisons or undesirable impurities contained in the feed or return/recycle streams. The guard beds may be employed in the vapor or liquid streams. Suitable guard bed materials are known in the art and include, for example, carbon, silica, alumina, ceramic, and/or resins. In one aspect, the guard bed media is functionalized to trap particular species such as sulfur or halogens. During the hydrogenation process, a crude ethanol product is withdrawn, preferably continuously, from reactor 103 via line 112. The crude ethanol product may be condensed and fed to flasher 106, which, in turn, provides a vapor stream and a liquid stream. The flasher 106 in one embodiment preferably operates at a temperature of from 50° C. to 500° C., e.g., from 70° C. to 400° C. or from 100° C. to 350° C. In one embodiment, the pressure of flasher 106 preferably is from 50 KPa to 2000 KPa, e.g., from 75 KPa to 1500 KPa or from 100 to 1000 KPa. In one preferred embodiment the temperature and pressure of the flasher is similar to the temperature and pressure of the reactor 103.

The vapor stream exiting the flasher 106 may comprise hydrogen and hydrocarbons, which may be purged and/or returned to reaction zone 101 via line 113. As shown in FIG. 1, the returned portion of the vapor stream passes through compressor 114 and is combined with hydrogen feed 104 and co-fed to vaporizer 110.

The liquid from flasher 106 is withdrawn and pumped as a feed composition via line 115 to the side of first column 107, also referred to as the acid separation column. The contents of line 115 typically will be substantially similar to the product obtained directly from the reactor, and may, in fact, also be characterized as a crude ethanol product. However, the feed composition in line 115 preferably has substantially no hydrogen, carbon dioxide, methane or ethane, which are removed by flasher 106. Exemplary compositions of line 115 are provided in Table 2. It should be understood that liquid line 115 may contain other components, not listed, such as components in the feed.

TABLE 2

FEED COMPOSITION			
	Conc. (wt. %)	Conc. (wt. %)	Conc. (wt. %)
Ethanol	5 to 70	10 to 60	15 to 50
Acetic Acid	<90	5 to 80	15 to 70
Water	5 to 35	5 to 30	10 to 30
Ethyl Acetate	<20	0.001 to 15	1 to 12
Acetaldehyde	<10	0.001 to 3	0.1 to 3
Acetal	<5	0.001 to 2	0.005 to 1
Acetone	<5	0.0005 to 0.05	0.001 to 0.03

TABLE 2-continued

FEED COMPOSITION			
	Conc. (wt. %)	Conc. (wt. %)	Conc. (wt. %)
Other Esters	<5	<0.005	<0.001
Other Ethers	<5	<0.005	<0.001
Other Alcohols	<5	<0.005	<0.001

The amounts indicated as less than (<) in the tables throughout the present application are preferably not present and if present may be present in trace amounts or in amounts not greater than 0.0001 wt. %.

The "other esters" in Table 2 may include, but are not limited to, ethyl propionate, methyl acetate, isopropyl acetate, n-propyl acetate, n-butyl acetate or mixtures thereof. The "other ethers" in Table 2 may include, but are not limited to, diethyl ether, methyl ethyl ether, isobutyl ethyl ether or mixtures thereof. The "other alcohols" in Table 2 may include, but are not limited to, methanol, isopropanol, n-propanol, n-butanol or mixtures thereof. In one embodiment, the feed composition, e.g., line 115, may comprise propanol, e.g., isopropanol and/or n-propanol, in an amount from 0.001 to 0.1 wt. %, from 0.001 to 0.05 wt. % or from 0.001 to 0.03 wt. %. It should be understood that these other components may be carried through in any of the distillate or residue streams described herein and will not be further described herein, unless indicated otherwise.

When the content of acetic acid in line 115 is less than 5 wt. %, the acid separation column 107 may be skipped and line 115 may be introduced directly to second column 108, also referred to herein as a light ends column.

In the embodiment shown in FIG. 1, line 115 is introduced in the lower part of first column 107, e.g., lower half or lower third. In first column 107, unreacted acetic acid, a portion of the water, and other heavy components, if present, are removed from the composition in line 115 and are withdrawn, preferably continuously, as residue. Preferably, residue from first column 107 comprises substantially all of the acetic acid from the crude ethanol product or liquid fed to the first column. Some or all of the residue may be returned and/or recycled back to reaction zone 101 via line 116. Recycling the acetic acid in line 116 to the vaporizer 110 may reduce the amount of heavies that need to be purged from vaporizer 110. Reducing the amount of heavies to be purged may improve efficiencies of the process while reducing byproducts.

First column 107 also forms an overhead distillate, which is withdrawn in line 117. The distillate, in one embodiment, may be condensed and refluxed, for example, at a ratio of from 10:1 to 1:10, e.g., from 3:1 to 1:3 or from 1:2 to 2:1.

Any of columns 107, 108, 109, or 123 may comprise any distillation column capable of separation and/or purification. The columns preferably comprise tray columns having from 1 to 150 trays, e.g., from 10 to 100, from 20 to 95 trays or from 30 to 75 trays. The trays may be sieve trays, fixed valve trays, movable valve trays, or any other suitable design known in the art. In other embodiments, a packed column may be used. For packed columns, structured packing or random packing may be employed. The trays or packing may be arranged in one continuous column or they may be arranged in two or more columns such that the vapor from the first section enters the second section while the liquid from the second section enters the first section, etc.

The associated condensers and liquid separation vessels that may be employed with each of the distillation columns may be of any conventional design and are simplified in FIGS. 1 and 2. As shown in FIGS. 1 and 2, heat may be

supplied to the base of each column or to a circulating bottom stream through a heat exchanger or reboiler. Other types of reboilers, such as internal reboilers, may also be used in some embodiments. The heat that is provided to reboilers may be derived from any heat generated during the process that is integrated with the reboilers or from an external source such as another heat generating chemical process or a boiler. Although one reactor and flasher are shown in FIGS. 1 and 2, additional reactors, flashers, condensers, heating elements, and other components may be used in embodiments of the present invention.

As will be recognized by those skilled in the art, various condensers, pumps, compressors, reboilers, drums, valves, connectors, separation vessels, etc., normally employed in carrying out chemical processes may also be combined and employed in the processes of the present invention.

The temperatures and pressures employed in any of the columns may vary. As a practical matter, pressures from 10 KPa to 3000 KPa will generally be employed in these zones although in some embodiments subatmospheric pressures may be employed as well as superatmospheric pressures. Temperatures within the various zones will normally range between the boiling points of the composition removed as the distillate and the composition removed as the residue. It will be recognized by those skilled in the art that the temperature at a given location in an operating distillation column is dependent on the composition of the material at that location and the pressure of column. In addition, feed rates may vary depending on the size of the production process and, if described, may be generically referred to in terms of feed weight ratios.

When column 107 is operated under standard atmospheric pressure, the temperature of the residue exiting in line 116 from column 107 preferably is from 95° C. to 120° C., e.g., from 105° C. to 117° C. or from 110° C. to 115° C. The temperature of the distillate exiting in line 117 from column 107 preferably is from 70° C. to 110° C., e.g., from 75° C. to 95° C. or from 80° C. to 90° C. Column 107 may operate at atmospheric pressure. In other embodiments, the pressure of first column 107 may range from 0.1 KPa to 510 KPa, e.g., from 1 KPa to 475 KPa or from 1 KPa to 375 KPa. Exemplary components of the distillate and residue compositions for first column 107 are provided in Table 3 below. It should also be understood that the distillate and residue may also contain other components, not listed, such as components in the feed. For convenience, the distillate and residue of the first column may also be referred to as the "first distillate" or "first residue." The distillates or residues of the other columns may also be referred to with similar numeric modifiers (second, third, etc.) in order to distinguish them from one another, but such modifiers should not be construed as requiring any particular separation order.

TABLE 3

FIRST COLUMN			
	Conc. (wt. %)	Conc. (wt. %)	Conc. (wt. %)
Distillate			
Ethanol	20 to 75	30 to 70	40 to 65
Water	10 to 40	15 to 35	20 to 35
Acetic Acid	<2	0.001 to 0.5	0.01 to 0.2
Ethyl Acetate	<60	5.0 to 40	10 to 30
Acetaldehyde	<10	0.001 to 5	0.01 to 4
Acetal	<0.1	<0.1	<0.05
Acetone	<0.05	0.001 to 0.03	0.01 to 0.025

13

TABLE 3-continued

FIRST COLUMN			
	Conc. (wt. %)	Conc. (wt. %)	Conc. (wt. %)
Residue			
Acetic Acid	60 to 100	70 to 95	85 to 92
Water	<30	1 to 20	1 to 15
Ethanol	<1	<0.9	<0.07

As shown in Table 3, without being bound by theory, it has surprisingly and unexpectedly been discovered that when any amount of acetal is detected in the feed that is introduced to the acid separation column (first column 107), the acetal appears to decompose in the column such that less or even no detectable amounts are present in the distillate and/or residue.

Depending on the reaction conditions, the crude ethanol product exiting reactor 103 in line 112 may comprise ethanol, acetic acid (unconverted), ethyl acetate, and water. After exiting reactor 103, a non-catalyzed equilibrium reaction may occur between the components contained in the crude ethanol product until it is added to flasher 106 and/or first column 107. This equilibrium reaction tends to drive the crude ethanol product to an equilibrium between ethanol/acetic acid and ethyl acetate/water, as shown below.

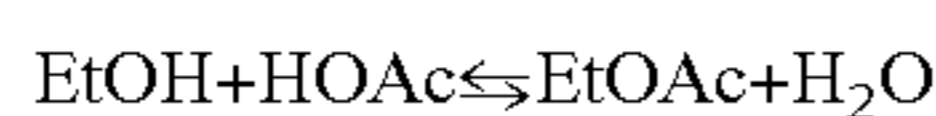

In the event the crude ethanol product is temporarily stored, e.g., in a holding tank, prior to being directed to distillation zone 102, extended residence times may be encountered. Generally, the longer the residence time between reaction zone 101 and distillation zone 102, the greater the formation of ethyl acetate. For example, when the residence time between reaction zone 101 and distillation zone 102 is greater than 5 days, significantly more ethyl acetate may form at the expense of ethanol. Thus, shorter residence times between reaction zone 101 and distillation zone 102 are generally preferred in order to maximize the amount of ethanol formed. In one embodiment, a holding tank (not shown), is included between the reaction zone 101 and distillation zone 102 for temporarily storing the liquid component from line 115 for up to 5 days, e.g., up to 1 day, or up to 1 hour. In a preferred embodiment no tank is included and the condensed liquids are fed directly to the first distillation column 107. In addition, the rate at which the non-catalyzed reaction occurs may increase as the temperature of the crude ethanol product, e.g., in line 115, increases. These reaction rates may be particularly problematic at temperatures exceeding 30° C., e.g., exceeding 40° C. or exceeding 50° C. Thus, in one embodiment, the temperature of liquid components in line 115 or in the optional holding tank is maintained at a temperature less than 40° C., e.g., less than 30° C. or less than 20° C. One or more cooling devices may be used to reduce the temperature of the liquid in line 115.

As discussed above, a holding tank (not shown) may be included between the reaction zone 101 and distillation zone 102 for temporarily storing the liquid component from line 115, for example from 1 to 24 hours, optionally at a temperature of about 21° C., and corresponding to an ethyl acetate formation of from 0.01 wt. % to 1.0 wt. % respectively. In addition, the rate at which the non-catalyzed reaction occurs may increase as the temperature of the crude ethanol product is increased. For example, as the temperature of the crude ethanol product in line 115 increases from 4° C. to 21° C., the rate of ethyl acetate formation may increase from about 0.01 wt. % per hour to about 0.005 wt. % per hour. Thus, in one

14

embodiment, the temperature of liquid components in line 115 or in the optional holding tank is maintained at a temperature less than 21° C., e.g., less than 4° C. or less than -10° C.

In addition, it has now been discovered that the above-described equilibrium reaction may also favor ethanol formation in the top region of first column 107.

The distillate, e.g., overhead stream, of column 107 optionally is condensed and refluxed as shown in FIG. 1, preferably, at a reflux ratio of 5:1 to 10:1. The distillate in line 117 preferably comprises ethanol, ethyl acetate, and water, along with other impurities, which may be difficult to separate due to the formation of binary and tertiary azeotropes.

The first distillate in line 117 is introduced to the second column 108, also referred to as the "light ends column," preferably in the middle part of column 108, e.g., middle half or middle third. As one example, when a 25 tray column is utilized in a column without water extraction, line 117 is introduced at tray 17. In one embodiment, the second column 108 may be an extractive distillation column. In such embodiments, an extraction agent, such as water, may be added to second column 108. If the extraction agent comprises water, it may be obtained from an external source or from an internal return/recycle line from one or more of the other columns. For example, the extraction agent may be at least a portion of the purified water stream from the third column. In one embodiment, at least a portion of the purified water in line 121 is recycled to second column 108, as indicated by line 121'. The molar ratio of the water in the extraction agent to the ethanol in the feed to the second column is preferably at least 0.5:1, e.g., at least 1:1 or at least 3:1. In terms of ranges, preferred molar ratios may range from 0.5:1 to 8:1, e.g., from 1:1 to 7:1 or from 2:1 to 6.5:1. Higher molar ratios may be used but with diminishing returns in terms of the additional ethyl acetate in the second distillate and decreased ethanol concentrations in the second column distillate.

Second column 108 may be a tray column or packed column. In one embodiment, second column 108 is a tray column having from 5 to 70 trays, e.g., from 15 to 50 trays or from 20 to 45 trays.

Although the temperature and pressure of second column 108 may vary, when at atmospheric pressure the temperature of the second residue exiting in line 118 from second column 108 preferably is from 60° C. to 90° C., e.g., from 70° C. to 90° C. or from 80° C. to 90° C. The temperature of the second distillate exiting in line 120 from second column 108 preferably is from 50° C. to 90° C., e.g., from 60° C. to 80° C. or from 60° C. to 70° C. Column 108 may operate at atmospheric pressure. In other embodiments, the pressure of second column 108 may be from 0.1 KPa to 510 KPa, e.g., from 1 KPa to 475 KPa or from 1 KPa to 375 KPa. Exemplary components of the second distillate and residue compositions for second column 108 are provided in Table 4 below. It should also be understood that the distillate and residue may also contain other components, not listed, such as components in the feed.

TABLE 4

SECOND COLUMN			
	Conc. (wt. %)	Conc. (wt. %)	Conc. (wt. %)
Distillate			
Ethyl Acetate	10 to 90	25 to 90	50 to 90
Acetaldehyde	1 to 25	1 to 15	1 to 8
Water	1 to 25	1 to 20	4 to 16

15

TABLE 4-continued

SECOND COLUMN			
	Conc. (wt. %)	Conc. (wt. %)	Conc. (wt. %)
Ethanol	<30	0.001 to 15	0.01 to 5
Acetal	<5	0.001 to 2	0.01 to 1
Residue			
Water	30 to 70	30 to 60	30 to 50
Ethanol	20 to 75	30 to 70	40 to 70
Ethyl Acetate	<3	0.001 to 2	0.001 to 0.5
Acetic Acid	<0.5	0.001 to 0.3	0.001 to 0.2

The weight ratio of ethanol in the second residue to second distillate preferably is at least 3:1, e.g., at least 6:1, at least 8:1, at least 10:1 or at least 15:1. The weight ratio of ethyl acetate in the second residue to second distillate preferably is less than 0.4:1, e.g., less than 0.2:1 or less than 0.1:1. In embodiments that use an extractive column with water as an extraction agent as the second column **108**, the weight ratio of ethyl acetate in the second residue to ethyl acetate in the second distillate approaches zero.

As shown, the second residue from the bottom of second column **108**, which comprises ethanol and water, is fed via line **118** to third column **109**. Column **109** may also be referred to as a "product column." More preferably, the second residue in line **118** is introduced in the lower part of third column **109**, e.g., lower half or lower third. Third column **109** recovers ethanol, which preferably is substantially pure other than the azeotropic water content, as the distillate in line **119**. The distillate of third column **109** preferably is refluxed as shown in FIG. **1**, for example, at a reflux ratio of from 1:10 to 10:1, e.g., from 1:3 to 3:1 or from 1:2 to 2:1.

Third column **109** is preferably a tray column as described above and preferably operates at atmospheric pressure. The temperature of the third distillate exiting in line **119** from third column **109** preferably is from 60° C. to 110° C., e.g., from 70° C. to 100° C. or from 75° C. to 95° C. The temperature of the third residue, e.g. the water stream, exiting third column **109** preferably is from 70° C. to 110° C., e.g., from 95° C. to 110° C. or from 100° C. to 105° C., when the column is operated at atmospheric pressure. In terms of lower limits, the temperature of the third residue exiting third column **109** is at least 102° C., e.g., at least 105° C. or at least 110° C.

Without being bound by theory, the water stream of the present invention comprises few, if any, impurities, the water stream may be disposed without the need for further processing. Thus, the conventional necessity for additional processing to remove impurities is advantageously minimized or eliminated. Beneficially, this lack of impurities may allow for disposal or reuse of the water stream at minimal costs.

The inventive water stream may be suitable for many uses. The uses for the water stream, in some cases, may be dependent upon the location of the facility at which the water stream is produced and the state or local government regulations that may apply thereto. For example, the inventive water stream may be suitable for use in industrial applications. As one example, the water stream may be recycled to the process and used in portions of the reaction zone or the separation zone where a water stream is needed. In one embodiment, the water stream may be used as an extraction agent in a distillation column, e.g. a second column, as discussed above. In another embodiment, the water stream may be used in hydrolysis reactions or in reactive distillation columns. In one embodiment, a portion of the third residue may be used to hydrolyze any other stream, such as one or more streams comprising ethyl acetate. The water stream may also be utilized as a

16

scrubber solvent, e.g., for a vent scrubber. Preferably, the water stream maybe utilized in the processes of the present invention. In other embodiments, the water stream maybe utilized in an independent process. As another option, the water stream may be used to maintain process equipment, e.g., to wash or clear tanks and towers. In a preferred embodiment, the water stream is used as cooling water. In this case, the water stream may be (biologically) treated to prevent algae growth. In other embodiments, the water stream may be used in agricultural applications. These uses are merely exemplary uses and this listing is not exclusive.

Exemplary components of the distillate composition and water stream for third column **109** are provided in Table 5 below. It should also be understood that the distillate may also contain other components, not listed, such as components in the feed.

TABLE 5

THIRD COLUMN			
	Conc. (wt. %)	Conc. (wt. %)	Conc. (wt. %)
Distillate			
Ethanol	75 to 96	80 to 96	85 to 96
Water	<12	1 to 9	3 to 8
Acetic Acid	<1	0.001 to 0.1	0.005 to 0.01
Ethyl Acetate	<5	0.001 to 4	0.01 to 3
Water Stream			
Water	97 to 100	98 to 100	99 to 100
Ethanol	<0.005	<0.002	<0.001
Ethyl Acetate	<0.001	<0.0005	not detectable
Acetic Acid	<0.5	<0.1	<0.05
Organic Impurities	<0.001	<0.0005	not detectable

Any of the compounds that are carried through the distillation process from the feed or crude reaction product generally remain in the third distillate in amounts of less 0.1 wt. %, based on the total weight of the third distillate composition, e.g., less than 0.05 wt. % or less than 0.02 wt. %. In one embodiment, one or more side streams may remove impurities from any of the columns **107**, **108** and/or **109** in the system **100**. Preferably at least one side stream is used to remove impurities from the third column **109**. The impurities may be purged and/or retained within the system **100**.

The third distillate in line **119** may be further purified to form an anhydrous ethanol product stream, i.e., "finished anhydrous ethanol," using one or more additional separation systems, such as, for example, distillation columns (e.g., a finishing column) or mole sieves.

Returning to second column **108**, the second distillate preferably is refluxed as shown in FIG. **1**, for example, at a reflux ratio of from 1:10 to 10:1, e.g., from 1:5 to 5:1 or from 1:3 to 3:1. In one embodiment, the ester feed stream comprises the all or a portion of the second distillate in line **120**.

In another embodiment, as shown in FIG. **2**, the second distillate is fed via line **120** to fourth column **123**, also referred to as the "acetaldehyde removal column." In fourth column **123** the second distillate is separated into a fourth distillate, which comprises acetaldehyde, in line **124**. The fourth distillate preferably is refluxed at a reflux ratio of from 1:20 to 20:1, e.g., from 1:15 to 15:1 or from 1:10 to 10:1, and a portion of the fourth distillate is returned to the reaction zone **101**. For example, the fourth distillate may be combined with the acetic acid feed, added to the vaporizer **110**, or added directly to the reactor **103**. As shown, the fourth distillate is co-fed with the acetic acid in feed line **105** to vaporizer **110**. Without being bound by theory, since acetaldehyde may be hydroge-

nated to form ethanol, the recycling of a stream that contains acetaldehyde to the reaction zone increases the yield of ethanol and decreases byproduct and waste generation. In another embodiment (not shown in the figure), the acetaldehyde may be collected and utilized, with or without further purification, to make useful products including but not limited to n-butanol, 1,3-butanediol, and/or crotonaldehyde and derivatives.

The fourth residue of fourth column 123 in line 125 primarily comprises ethyl acetate and water and is highly suitable for use as an ester feed stream. In one preferred embodiment, the acetaldehyde is removed from the second distillate in fourth column 123 such that no detectable amount of acetaldehyde is present in the residue of column 123.

Fourth column 123 is preferably a tray column as described above and preferably operates above atmospheric pressure. In one embodiment, the pressure is from 120 KPa to 5,000 KPa, e.g., from 200 KPa to 4,500 KPa, or from 400 KPa to 3,000 KPa. In a preferred embodiment the fourth column 123 may operate at a pressure that is higher than the pressure of the other columns.

The temperature of the fourth distillate exiting in line 124 from fourth column 123 preferably is from 60° C. to 110° C., e.g., from 70° C. to 100° C. or from 75° C. to 95° C. The temperature of the residue exiting from fourth column 125 preferably is from 70° C. to 115° C., e.g., from 80° C. to 110° C. or from 85° C. to 110° C. Exemplary components of the distillate and residue compositions for fourth column 109 are provided in Table 6 below. It should also be understood that the distillate and residue may also contain other components, not listed, such as components in the feed.

TABLE 6

FOURTH COLUMN			
	Conc. (wt. %)	Conc. (wt. %)	Conc. (wt. %)
Distillate			
Acetaldehyde	2 to 80	2 to 50	5 to 40
Ethyl Acetate	<90	30 to 80	40 to 75
Ethanol	<30	0.001 to 25	0.01 to 20
Water	<25	0.001 to 20	0.01 to 15
Residue			
Ethyl Acetate	40 to 100	50 to 100	60 to 100
Ethanol	<40	0.001 to 30	0 to 15
Water	<25	0.001 to 20	2 to 15
Acetaldehyde	<1	0.001 to 0.5	Not detectable
Acetal	<3	0.001 to 2	0.01 to 1

The finished ethanol composition obtained by the processes of the present invention preferably comprises from 75 to 96 wt. % ethanol, e.g., from 80 to 96 wt. % or from 85 to 96 wt. % ethanol, based on the total weight of the finished ethanol composition. Exemplary finished ethanol compositional ranges are provided below in Table 7.

TABLE 7

FINISHED ETHANOL COMPOSITIONS			
Component	Conc. (wt. %)	Conc. (wt. %)	Conc. (wt. %)
Ethanol	75 to 96	80 to 96	85 to 96
Water	<12	1 to 9	3 to 8
Acetic Acid	<1	<0.1	<0.01
Ethyl Acetate	<2	<0.5	<0.05
Acetal	<0.05	<0.01	<0.005
Acetone	<0.05	<0.01	<0.005

TABLE 7-continued

FINISHED ETHANOL COMPOSITIONS			
Component	Conc. (wt. %)	Conc. (wt. %)	Conc. (wt. %)
Isopropanol	<0.5	<0.1	<0.05
n-propanol	<0.5	<0.1	<0.05

The finished ethanol composition of the present invention preferably contains very low amounts, e.g., less than 0.5 wt. %, of other alcohols, such as methanol, butanol, isobutanol, isoamyl alcohol and other C₄-C₂₀ alcohols. In one embodiment, the amount of isopropanol in the finished ethanol is from 95 to 1,000 wppm, e.g., from 100 to 700 wppm, or from 150 to 500 wppm. In one embodiment, the finished ethanol composition preferably is substantially free of acetaldehyde and may comprise less than 8 wppm of acetaldehyde, e.g., less than 5 wppm or less than 1 wppm.

The finished ethanol composition produced by the embodiments of the present invention may be used in a variety of applications including fuels, solvents, chemical feedstocks, pharmaceutical products, cleansers, sanitizers, hydrogenation transport or consumption. In fuel applications, the finished ethanol composition may be blended with gasoline for motor vehicles such as automobiles, boats and small piston engine aircrafts. In non-fuel applications, the finished ethanol composition may be used as a solvent for toiletry and cosmetic preparations, detergents, disinfectants, coatings, inks, and pharmaceuticals. The finished ethanol composition may also be used as a processing solvent in manufacturing processes for medicinal products, food preparations, dyes, photochemicals and latex processing.

The finished ethanol composition may also be used a chemical feedstock to make other chemicals such as vinegar, ethyl acrylate, ethyl acetate, ethylene, glycol ethers, ethylamines, aldehydes, and higher alcohols, especially butanol. In the production of ethyl acetate, the finished ethanol composition may be esterified with acetic acid or reacted with polyvinyl acetate. The finished ethanol composition may be dehydrated to produce ethylene. Any of known dehydration catalysts can be employed in to dehydrate ethanol, such as those described in U.S. Pub. No. 20100030002 and 20100030001, the entire contents and disclosures of which are hereby incorporated by reference. A zeolite catalyst, for example, may be employed as the dehydration catalyst. Preferably, the zeolite has a pore diameter of at least about 0.6 nm, and preferred zeolites include dehydration catalysts selected from the group consisting of mordenites, ZSM-5, a zeolite X and a zeolite Y. Zeolite X is described, for example, in U.S. Pat. No. 2,882,244 and zeolite Y in U.S. Pat. No. 3,130,007, the entireties of which are hereby incorporated by reference. In order that the invention disclosed herein may be more efficiently understood, an example is provided below. The following examples describe the various distillation processes of the present invention.

EXAMPLES

Example 1

A crude ethanol product comprising ethanol, acetic acid, water and ethyl acetate was produced by reacting a vaporized feed comprising 95.2 wt. % acetic acid and 4.6 wt. % water with hydrogen in the presence of a catalyst comprising 1.6 wt. % platinum and 1 wt. % tin supported on 1/8 inch calcium silicate modified silica extrudates at an average temperature of 291° C., an outlet pressure of 2,063 KPa. Unreacted hydro-

19

gen was recycled back to the inlet of the reactor such that the total H₂/acetic acid molar ratio was 5.8 at a GHSV of 3,893 W^f. Under these conditions, 42.8% of the acetic acid was converted, and the selectivity to ethanol was 87.1%, selectivity to ethyl acetate was 8.4%, and selectivity to acetaldehyde was 3.5%. The crude ethanol product was purified using a separation scheme having distillation columns as shown in FIG. 1.

The crude ethanol product was fed to the first column at a feed rate of 20 g/min. The composition of the liquid feed is provided in Table 8. The first column was a 2 inch diameter Oldershaw with 50 trays. The column was operated at a temperature of 115° C. at atmospheric pressure. Unless otherwise indicated, a column operating temperature is the temperature of the liquid in the reboiler and the pressure at the top of the column is ambient (approximately one atmosphere). The column differential pressure between the trays in the first column was 7.4 KPa. The first residue was withdrawn at a flow rate of 12.4 g/min and returned to the hydrogenation reactor.

The first distillate was condensed and refluxed at a 1:1 ratio at the top of the first column, and a portion of the distillate was introduced to the second column at a feed rate of 7.6 g/min. The second column is a 2 inch diameter Oldershaw design equipped with 25 trays. The second column was operated at a temperature of 82° C. at atmospheric pressure. The column differential pressure between the trays in the second column was 2.6 KPa. The second residue was withdrawn at a flow rate of 5.8 g/min. The second distillate was refluxed at a ratio of 4.5:0.5 and the remaining distillate was collected as the ester feed stream for analysis.

TABLE 8

Component	First Column			Second Column	
	Feed (wt. %)	Distillate (wt. %)	Residue (wt. %)	Distillate (wt. %)	Residue (wt. %)
Water	13.8	24.7	5.6	5.1	30.8
Acetaldehyde	nd	1.8	nd	8.3	nd
Acetic Acid	55.0	0.08	93.8	0.03	0.1
Ethanol	23.4	57.6	0.06	12.4	67.6
Ethyl Acetate	6.5	15.1	nd	76.0	nd
Acetal	0.7	0.1	nd	0.006	0.03
Acetone	nd	0.01	nd	0.03	nd

Example 2

A feed stream having a similar composition as residue from the second column from Example 1 was collected from several runs and introduced above the 25 tray to the third column, a 2 inch Oldershaw containing 60 trays, at a rate of 10 g/min. The third column was operated at a temperature of 103° C. at standard pressure. The column differential pressure between the trays in the third column was 6.2 KPa. The third residue, e.g., the water stream, was withdrawn at a flow rate of 2.7 g/min. The third distillate was condensed and refluxed at a 3:1 ratio at the top of the third column. An ethanol composition as shown in Table 9 was recovered. The ethanol composition also contained 10 ppm of n-butyl acetate.

20

TABLE 9

Component	Feed (wt. %)	Third Column	
		Distillate (wt. %)	Residue (wt. %)
Acetic Acid	0.098	0.001	0.4
Ethanol	65.7	93.8	0.004
Water	35.5	6.84	98
Ethyl Acetate	1.37	1.8	—
Acetal	0.02	0.03	—
Isopropanol	0.004	0.005	—
n-propanol	0.01	0	—

As shown in Table 9, the residue of the third column, e.g., the water stream, is surprisingly and unexpectedly free of organic impurities other than acetic acid and ethanol. As such, the water stream may be easily disposed of without further processing.

Example 3

A crude ethanol product comprising ethanol, acetic acid, water and ethyl acetate was produced by reacting a vaporized feed comprising 96.3 wt. % acetic acid and 4.3 wt. % water with hydrogen in the presence of a catalyst comprising 1.6 wt. % platinum and 1% tin supported on 1/8 inch calcium silicate modified silica extrudates at an average temperature of 290° C., an outlet pressure of 2,049 kPa. Unreacted hydrogen was recycled back to the inlet of the reactor such that the total H₂/acetic acid molar ratio was 10.2 at a GHSV of 1,997 hr⁻¹. Under these conditions, 74.5% of the acetic acid was converted, and the selectivity to ethanol was 87.9%, selectivity to ethyl acetate was 9.5%, and selectivity to acetaldehyde was 1.8%. The crude ethanol product was purified using a separation scheme having distillation columns as shown in FIG. 1.

The crude ethanol product was fed to the first column at a feed rate of 20 g/min. The composition of the liquid feed is provided in Table 10. The first column is a 2 inch diameter Oldershaw with 50 trays. The column was operated at a temperature of 116° C. at atmospheric pressure. The column differential pressure between the trays in the first column was 8.1 KPa. The first residue was withdrawn at a flow rate of 10.7 g/min and returned to the hydrogenation reactor.

The first distillate was condensed and refluxed at a 1:1 ratio at the top of the first column, and a portion of the distillate was introduced to the second column at a feed rate of 9.2 g/min. The second column was a 2 inch diameter Oldershaw design equipped with 25 trays. The second column was operated at a temperature of 82° C. at atmospheric pressure. The column differential pressure between the trays in the second column was 2.4 KPa. The second residue was withdrawn at a flow rate of 7.1 g/min. The second distillate was refluxed at a ratio of 4.5:0.5 and the remaining distillate was collected as the ester feed stream for analysis.

TABLE 10

Component	First Column			Second Column	
	Feed (wt. %)	Distillate (wt. %)	Residue (wt. %)	Distillate (wt. %)	Residue (wt. %)
Water	14.6	27.2	3.7	3.0	36.2
Acetaldehyde	nd	1.5	nd	10.3	nd
Acetic Acid	49.1	0.2	98.2	0.04	0.3
Ethanol	27.6	54.5	0.04	13.3	64.4

TABLE 10-continued

Component	First Column		Second Column		
	Feed (wt. %)	Distillate (wt. %)	Residue (wt. %)	Distillate (wt. %)	Residue (wt. %)
Ethyl Acetate	7.9	15.2	nd	75.7	1.8
Acetal	0.7	0.1	nd	0.01	0.02
Acetone	nd	0.01	nd	0.03	nd

Example 4

A feed stream having a similar composition as residue from the second column from Example 3 was collected from several runs and introduced above the 25 tray to the third column, a 2 inch Oldershaw containing 60 trays, at a rate of 20 g/min. The third column was operated at a temperature of 103° C. at standard pressure. The column differential pressure between the trays in the third column was 6.5 KPa. The third residue, e.g., the water stream, was withdrawn at a flow rate of 13.8 g/min. The third distillate was condensed and refluxed at a 3:2 ratio at the top of the third column. An ethanol composition as shown in Table 11 was recovered. The ethanol composition also contained 118 ppm of isopropanol and 122 ppm of n-propanol.

TABLE 11

Component	Third Column		
	Feed (wt. %)	Distillate (wt. %)	Residue (wt. %)
Acetic Acid	0.06	0	0.088
Ethanol	25.2	92.5	0.0012
Water	72.6	7.5	99.9
Ethyl Acetate	0.0007	0.0019	—

As shown in Table 11, the residue of the third column, e.g., the water stream, is surprisingly and unexpectedly free of organic impurities other than acetic acid and ethanol. As such, the water stream may be easily disposed of without further processing.

While the invention has been described in detail, modifications within the spirit and scope of the invention will be readily apparent to those of skill in the art. In view of the foregoing discussion, relevant knowledge in the art and references discussed above in connection with the Background and Detailed Description, the disclosures of which are all incorporated herein by reference. In addition, it should be understood that aspects of the invention and portions of various embodiments and various features recited below and/or in the appended claims may be combined or interchanged either in whole or in part. In the foregoing descriptions of the various embodiments, those embodiments which refer to another embodiment may be appropriately combined with other embodiments as will be appreciated by one of skill in the art. Furthermore, those of ordinary skill in the art will appreciate that the foregoing description is by way of example only, and is not intended to limit the invention.

We claim:

1. A process for producing a water stream, comprising the steps of:

hydrogenating acetic acid in a reactor in the presence of a catalyst to form a crude ethanol product;

separating at least a portion of the crude ethanol product in a first column into a first distillate comprising ethanol, water and ethyl acetate, and a first residue comprising acetic acid;

separating at least a portion of the first distillate in a second column into a second distillate comprising ethyl acetate and a second residue comprising ethanol and water;

separating at least a portion of the second residue in a third column into a third distillate comprising ethanol and a third residue;

hydrolyzing at least a portion of the second distillate with at least a portion of the third residue,

wherein the third residue comprises:

at least 97 wt. % water;

less than 0.5 wt. % acetic acid;

less than 0.005 wt. % ethanol; and

less than 0.001 wt. % ethyl acetate.

2. The process of claim 1, wherein the crude ethanol product comprises ethanol, water, ethyl acetate, and acetic acid.

3. The process of claim 1, wherein at least a portion of the third residue is directed to the second column.

4. The process of claim 1, wherein the crude ethanol product comprises ethanol in an amount of from 5 to 70 wt. %, water in an amount of from 5 to 35 wt. %, acetic acid in an amount of from 0 to 90 wt. %, and ethyl acetate in an amount of from 0 to 20 wt. %.

5. The process of claim 1, further comprising:

hydrolyzing at least a portion of the first distillate with at least a portion of the third residue.

6. The process of claim 1, further comprising:

separating at least a portion of the second distillate in a fourth column into a fourth distillate comprising acetaldehyde and a fourth residue comprising ethyl acetate.

7. The process of claim 6, further comprising:

hydrolyzing at least a portion of the fourth residue with at least a portion of the third residue.

8. The process of claim 1, wherein the water stream is essentially free of organic impurities other than acetic acid and ethanol, and wherein the organic impurities are selected from the group consisting of ethyl acetate, acetaldehyde, acetone, acetal and mixtures thereof.

9. The process of claim 1, wherein the hydrogenating is conducted over a catalyst comprising a combination of metals selected from the group consisting of platinum/tin, platinum/ruthenium, platinum/rhenium, palladium/ruthenium, palladium/rhenium, cobalt/palladium, cobalt/platinum, cobalt/chromium, cobalt/ruthenium, silver/palladium, copper/palladium, nickel/palladium, gold/palladium, ruthenium/rhenium, and ruthenium/iron.

10. The process of claim 1, wherein the water stream has a pH ranging from 2.99 to 3.35.

11. A process for producing a water stream, the process comprising:

hydrogenating a feed stream comprising acetic acid to form a crude ethanol product comprising ethanol, water, ethyl acetate, and acetic acid;

separating at least a portion of the crude ethanol product to form at least one ethanol stream comprising ethanol and ethyl acetate and a water stream comprising:

at least 97 wt. % water;

less than 0.5 wt. % acetic acid;

less than 0.005 wt. % ethanol; and

less than 0.001 wt. % ethyl acetate; and

hydrolyzing at least a portion of the ethyl acetate in the at least one ethanol stream with at least a portion of the water stream to form a hydrolyzed stream comprising ethanol.

23

12. The process of claim 11, wherein the separating step comprises:

separating at least a portion of the crude ethanol product to form a first ethanol stream comprising ethanol and ethyl acetate and a first acetic acid stream.

13. The process of claim 12, wherein the hydrolyzing step comprises:

hydrolyzing at least a portion of the ethyl acetate in the first ethanol stream with at least a portion of the at least one water stream to form the hydrolyzed stream.

14. The process of claim 12, wherein the separating step further comprises:

separating at least a portion of the first ethanol stream to form a second ethanol stream comprising ethanol and ethyl acetate and a first water stream comprising ethanol and water and a second water stream comprising:

at least 97 wt. % water;
less than 0.5 wt. % acetic acid;
less than 0.005 wt. % ethanol; and
less than 0.001 wt. % ethyl acetate.

15. The process of claim 14, wherein the hydrolyzing step comprises:

hydrolyzing at least a portion of the ethyl acetate in the second ethanol stream with at least a portion of the second water stream to form the hydrolyzed stream.

16. The process of claim 14, wherein the separating step further comprises:

separating at least a portion of the first water stream to form a third ethanol stream comprising ethanol and ethyl acetate and the second water stream;

separating at least a portion of the second ethanol stream to form an acetaldehyde stream and a fourth ethanol stream comprising ethanol and ethyl acetate.

24

17. The process of claim 16, wherein the hydrolyzing step comprises:

hydrolyzing at least a portion of the ethyl acetate in the fourth ethanol stream with at least a portion of the second water stream to form the hydrolyzed stream.

18. The process of claim 16, wherein the hydrolyzing step comprises:

hydrolyzing at least a portion of the first ethanol stream and at least a portion of the fourth ethanol stream with at least a portion of the second water stream to form the hydrolyzed stream.

19. A process for purifying a crude ethanol product, comprising the steps of:

providing the crude ethanol product comprising ethanol, water, acetic acid, and ethyl acetate;

separating at least a portion of the crude ethanol product to form an ethyl acetate-containing stream and at least one water stream comprising

at least 97 wt. % water;
less than 0.5 wt. % acetic acid;
less than 0.005 wt. % ethanol; and
less than 0.001 wt. % ethyl acetate; and

hydrolyzing at least a portion of the ethyl acetate-containing stream with at least a portion of the water stream to form a hydrolyzed stream comprising ethanol.

20. The process of claim 19, wherein the crude ethanol product comprises ethanol in an amount of from 5 to 70 wt. %, water in an amount of from 5 to 35 wt. %, acetic acid in an amount of from 0 to 90 wt. %, and ethyl acetate in an amount of from 0 to 20 wt. %.

* * * * *