



US008652208B2

(12) **United States Patent**
Baird et al.

(10) **Patent No.:** **US 8,652,208 B2**
(45) **Date of Patent:** ***Feb. 18, 2014**

(54) **METHODS AND SYSTEMS FOR MATERIAL FIXATION**

(75) Inventors: **Kevin N. Baird**, Phoenix, AZ (US); **Derek J. Harper**, Prescott, AZ (US); **Joe P. Kovalski**, Ventura, CA (US); **Joanne Kovalski**, legal representative, Ventura, CA (US); **Kenneth D. Montgomery**, Roslyn, NY (US)

(73) Assignee: **Cayenne Medical, Inc.**, Scottsdale, AZ (US)

(*) Notice: Subject to any disclaimer, the term of this patent is extended or adjusted under 35 U.S.C. 154(b) by 0 days.

This patent is subject to a terminal disclaimer.

(21) Appl. No.: **13/014,441**

(22) Filed: **Jan. 26, 2011**

(65) **Prior Publication Data**

US 2011/0184516 A1 Jul. 28, 2011

Related U.S. Application Data

(63) Continuation of application No. 11/923,526, filed on Oct. 24, 2007, now Pat. No. 7,879,094.

(60) Provisional application No. 60/854,178, filed on Oct. 24, 2006.

(51) **Int. Cl.**
A61F 2/08 (2006.01)
A61B 17/04 (2006.01)
F16B 13/04 (2006.01)

(52) **U.S. Cl.**
USPC **623/13.14**; 623/13.11; 623/13.12;
411/32; 606/62; 606/300

(58) **Field of Classification Search**
USPC 623/13.11–13.14, 16.11; 606/62–65,
606/67, 68, 198, 232, 300, 301, 310, 313,
606/319, 320, 321, 326; 411/16, 32, 80.1,
411/80.5, 18

See application file for complete search history.

(56) **References Cited**

U.S. PATENT DOCUMENTS

3,708,883 A 1/1973 Flander
3,832,931 A 9/1974 Talan

(Continued)

FOREIGN PATENT DOCUMENTS

CA 2235354 A1 10/1999
EP 0232049 B1 3/1990

(Continued)

OTHER PUBLICATIONS

Caborn et al., A Biomechanical Comparison of Initial Soft Tissue Tibial Fixation Devices: The Intrafix Versus a Tapered 35-mm Bioabsorbable Interference Screw, *The American Journal of Sports Medicine*, 2004, vol. 32, No. 4.

(Continued)

Primary Examiner — David Isabella

Assistant Examiner — Yashita Sharma

(74) *Attorney, Agent, or Firm* — Stout, Uxa, Buyan & Mullins, LLP; Donald E. Stout

(57) **ABSTRACT**

A soft tissue fixation system, most typically applicable to orthopedic joint repairs, such as anterior cruciate ligament (ACL) knee repair procedures, comprises an implant which is placeable in a tunnel disposed in a portion of bone, wherein the tunnel is defined by walls comprised of bone. A first member is deployable outwardly to engage the tunnel walls for anchoring the implant in place in the tunnel, and a second member is deployable outwardly to engage tissue material to be fixed within the tunnel. The second member also functions to move the tissue material outwardly into contact with the tunnel walls to promote tendon-bone fixation. Extra graft length is eliminated by compression of the tendon against the bone at the aperture of the femoral tunnel, which more closely replicates the native ACL and increases graft stiffness. The inventive device provides high fixation of tendon to bone and active tendon-bone compression. Graft strength has been found to be greater than 1,000 N (Newtons), which is desirable for ACL reconstruction systems.

19 Claims, 15 Drawing Sheets

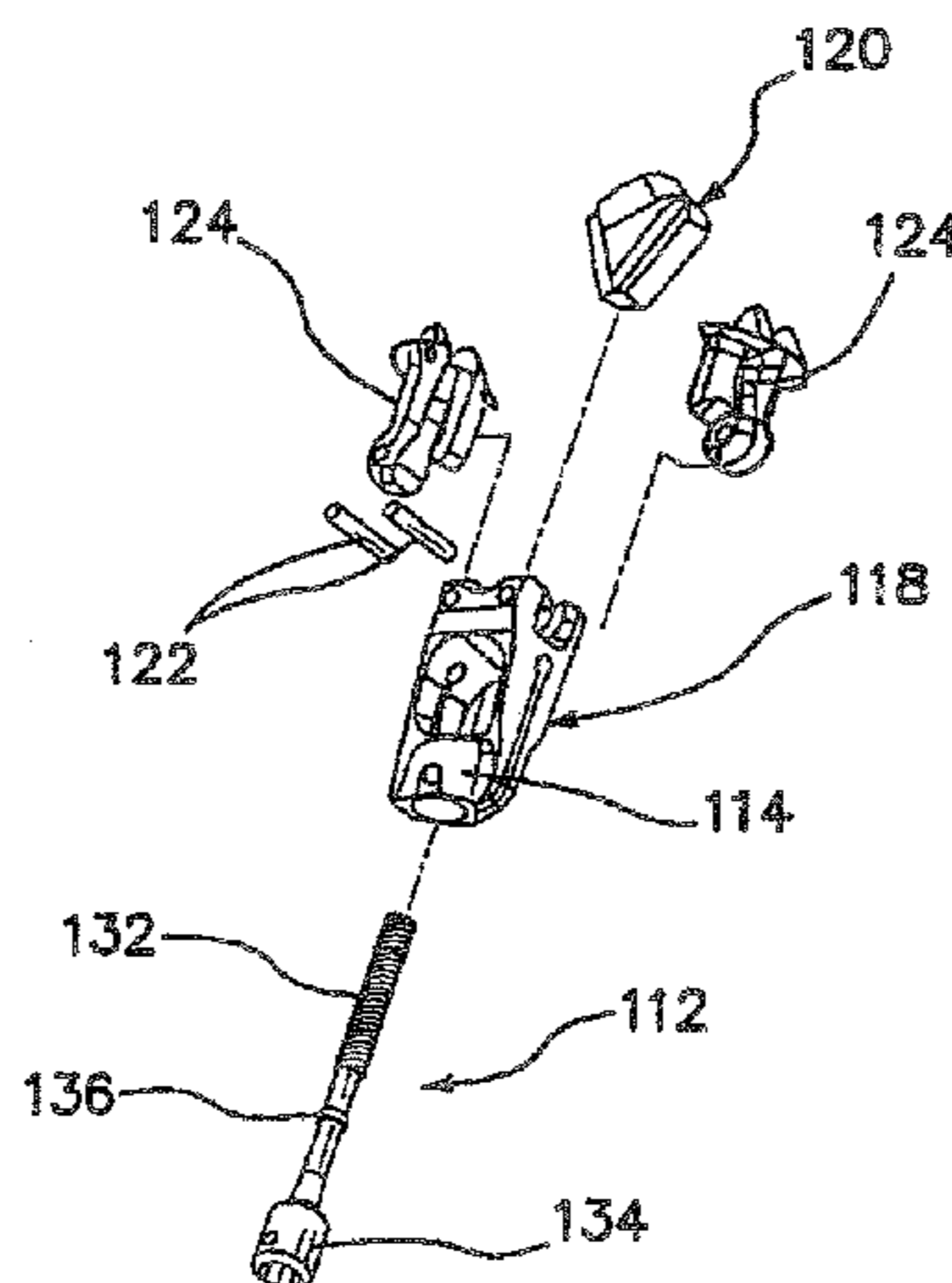

(56)

References Cited

U.S. PATENT DOCUMENTS

4,311,421	A	1/1982	Okada et al.	5,961,520	A	10/1999	Beck, Jr. et al.
4,711,232	A	12/1987	Fischer et al.	5,964,764	A	10/1999	West, Jr. et al.
4,716,893	A	1/1988	Fischer et al.	5,968,078	A	10/1999	Grotz
4,738,255	A	4/1988	Goble et al.	5,993,459	A	11/1999	Larsen et al.
4,744,793	A	5/1988	Parr et al.	6,017,346	A	1/2000	Grotz
4,772,286	A	9/1988	Goble et al.	6,086,608	A	7/2000	Ek et al.
4,778,468	A	10/1988	Hunt et al.	6,099,530	A	8/2000	Simonian et al.
4,828,562	A	5/1989	Kenna	6,113,609	A	9/2000	Adams
4,870,957	A	10/1989	Goble et al.	6,117,173	A	9/2000	Taddia et al.
4,955,910	A	9/1990	Bolesky	6,132,433	A	10/2000	Whelan
4,957,498	A	9/1990	Caspari et al.	6,146,406	A	11/2000	Shluzas et al.
5,004,474	A	4/1991	Fronk et al.	6,152,928	A	11/2000	Wenstrom, Jr.
5,037,422	A	8/1991	Hayhurst et al.	6,179,840	B1	1/2001	Bowman
5,085,661	A	2/1992	Moss	6,187,008	B1	2/2001	Hamman
5,139,520	A	8/1992	Rosenberg	6,190,411	B1	2/2001	Lo
5,161,916	A	11/1992	White et al.	6,214,007	B1	4/2001	Anderson
5,176,709	A	1/1993	Branemark	6,221,107	B1	4/2001	Steiner et al.
5,188,636	A	2/1993	Fedotov	6,325,804	B1	12/2001	Wenstrom, Jr. et al.
5,211,647	A	5/1993	Schmieding	6,328,758	B1	12/2001	Tornier et al.
5,234,430	A	8/1993	Huebner	6,355,066	B1	3/2002	Kim
5,236,445	A	8/1993	Hayhurst et al.	6,379,361	B1	4/2002	Beck, Jr. et al.
5,258,016	A	11/1993	DiPoto et al.	6,387,129	B2	5/2002	Rieser et al.
5,268,001	A	12/1993	Nicholson et al.	6,461,373	B2	10/2002	Wyman et al.
5,281,237	A	1/1994	Gimpelson	6,482,210	B1	11/2002	Skiba et al.
5,320,626	A	6/1994	Schmieding	6,517,579	B1	2/2003	Paulos et al.
5,336,240	A	8/1994	Metzler et al.	6,533,795	B1	3/2003	Tran et al.
5,350,383	A	9/1994	Schmieding et al.	6,533,816	B2	3/2003	Sklar
5,354,298	A	10/1994	Lee et al.	6,551,330	B1	4/2003	Bain et al.
5,356,435	A	10/1994	Thein	6,554,862	B2	4/2003	Hays et al.
5,374,269	A	12/1994	Rosenberg	6,562,071	B2	5/2003	Jarvinen
5,383,878	A	1/1995	Roger et al.	6,575,973	B1	6/2003	Shekalim
5,411,523	A	5/1995	Goble	6,616,694	B1	9/2003	Hart
5,431,651	A	7/1995	Goble	6,623,524	B2	9/2003	Schmieding
5,431,666	A	7/1995	Sauer et al.	6,632,245	B2	10/2003	Kim
5,439,467	A	8/1995	Benderev et al.	6,648,890	B2	11/2003	Culbert et al.
5,456,685	A	10/1995	Huebner	6,656,183	B2	12/2003	Colleran et al.
5,464,427	A	11/1995	Curtis et al.	6,685,706	B2	2/2004	Padget et al.
5,466,237	A	11/1995	Byrd et al.	6,689,135	B2	2/2004	Enayati
5,474,555	A	12/1995	Puno et al.	6,716,234	B2	4/2004	Grafton et al.
5,480,403	A	1/1996	Lee et al.	6,719,509	B1	4/2004	Huang et al.
5,486,197	A	1/1996	Le et al.	6,730,124	B2	5/2004	Steiner
5,507,750	A	4/1996	Goble et al.	6,736,829	B1	5/2004	Li et al.
5,571,104	A	11/1996	Li	6,736,847	B2	5/2004	Seyr et al.
5,571,184	A	11/1996	DeSatnick	6,752,831	B2	6/2004	Sybert et al.
5,575,819	A	11/1996	Amis	6,770,073	B2	8/2004	McDevitt et al.
5,601,562	A	2/1997	Wolf et al.	6,770,084	B1	8/2004	Bain et al.
5,603,716	A	2/1997	Morgan et al.	6,780,188	B2	8/2004	Clark et al.
5,618,314	A	4/1997	Harwin et al.	6,796,977	B2	9/2004	Yap et al.
5,632,748	A	5/1997	Beck, Jr. et al.	6,802,862	B1	10/2004	Roger et al.
5,645,589	A	7/1997	Li	6,833,005	B1	12/2004	Mantas et al.
5,702,215	A	12/1997	Li	6,887,271	B2	5/2005	Justin et al.
5,702,397	A	12/1997	Goble et al.	6,890,354	B2	5/2005	Steiner et al.
5,707,395	A	1/1998	Li	6,932,841	B2	8/2005	Sklar et al.
5,713,903	A	2/1998	Sander et al.	6,939,379	B2	9/2005	Sklar
5,718,706	A	2/1998	Roger	6,942,666	B2	9/2005	Overaker et al.
5,725,341	A	3/1998	Hofmeister	6,942,668	B2	9/2005	Padget et al.
5,725,529	A	3/1998	Nicholson et al.	6,986,781	B2	1/2006	Smith
5,725,541	A	3/1998	Anspach, III et al.	7,008,451	B2	3/2006	Justin et al.
5,728,136	A	3/1998	Thal	7,037,324	B2	5/2006	Martinek
5,741,300	A	4/1998	Li	7,083,638	B2	8/2006	Foerster
5,743,912	A	4/1998	Lahille et al.	7,147,651	B2	12/2006	Morrison et al.
5,769,894	A	6/1998	Ferragamo	7,201,754	B2	4/2007	Stewart et al.
5,782,865	A	7/1998	Grotz	7,309,355	B2	12/2007	Donnelly et al.
5,814,073	A	9/1998	Bonutti	7,326,247	B2	2/2008	Schmieding et al.
5,845,645	A	12/1998	Bonutti	7,556,629	B2	7/2009	Von Hoffmann et al.
5,846,254	A	12/1998	Schulze et al.	7,556,640	B2	7/2009	Foerster
5,871,504	A	2/1999	Eaton et al.	2002/0120280	A1	8/2002	Wotton, III
5,899,938	A	5/1999	Sklar et al.	2002/0165611	A1	11/2002	Enzerink et al.
5,902,303	A	5/1999	Eckhof et al.	2003/0065391	A1	4/2003	Re et al.
5,911,721	A	6/1999	Nicholson et al.	2003/0083662	A1	5/2003	Middleton
RE36,289	E	8/1999	Le et al.	2003/0109900	A1	6/2003	Martinek
5,931,869	A	8/1999	Boucher et al.	2003/0135274	A1	7/2003	Hays et al.
5,935,129	A	8/1999	McDevitt et al.	2003/0199877	A1	10/2003	Steiger et al.
5,941,901	A	8/1999	Egan	2003/0204204	A1	10/2003	Bonutti
5,957,953	A	9/1999	DiPoto et al.	2004/0024456	A1	2/2004	Brown, Jr. et al.
				2004/0068267	A1	4/2004	Harvie et al.
				2004/0097943	A1	5/2004	Hart
				2004/0098050	A1	5/2004	Foerster et al.
				2004/0098052	A1	5/2004	West, Jr. et al.

(56)

References Cited

U.S. PATENT DOCUMENTS

2004/0153153	A1	8/2004	Elson et al.
2004/0180308	A1	9/2004	Ebi et al.
2004/0181240	A1	9/2004	Tseng et al.
2004/0199165	A1	10/2004	Culbert et al.
2004/0230194	A1	11/2004	Urbanski et al.
2004/0237362	A1	12/2004	O'Connell
2004/0267362	A1	12/2004	Hwang et al.
2005/0033289	A1	2/2005	Warren et al.
2005/0251260	A1	11/2005	Gerber et al.
2006/0095131	A1	5/2006	Justin et al.
2006/0155287	A1	7/2006	Montgomery et al.
2006/0235413	A1	10/2006	Denham et al.
2007/0166122	A1	7/2007	McDuff et al.
2008/0119929	A1	5/2008	Schmieding et al.

FOREIGN PATENT DOCUMENTS

EP	0528573	A1	8/1992
EP	0688185	A1	2/1993
EP	1033115	A2	9/2000
EP	0762850	B1	2/2004
EP	0739185	B1	9/2004
EP	1011535	B1	12/2005
FR	2696925	A1	4/1994
JP	10155820	A	6/1998
WO	8809157		12/1988
WO	9216167	A1	10/1992
WO	9515726	A1	6/1995
WO	9812991	A1	4/1998
WO	9818409		5/1998
WO	0130253	A1	5/2001
WO	WO 02/32345	A2	4/2002
WO	02085256	A1	10/2002

OTHER PUBLICATIONS

Charlton et al., Clinical Outcome of Anterior Cruciate Ligament Reconstruction with Quadrupled Hamstring Tendon Graft and

Bioabsorbable Interference Screw Fixation, *The American Journal of Sports Medicine*, 2003, pp. 518-521, vol. 31, No. 4, Kerlan-Jobe Orthopaedic Clinic, Los Angeles.

Morgan et al., Anatomic Graft Fixation Using a Retrograde Biointerference Screw for Endoscopic Anterior Cruciate Ligament Reconstruction: Single-Bundle and 2-Bundle Techniques, *Techniques in Orthopaedics*, 2005, pp. 297-302, vol. 20, No. 3, Lippincott Williams & Wilkins, Inc., Philadelphia.

Robbe et al., Graft Fixation Alternatives in Anterior Cruciate Ligament Reconstruction, *Spring 2002*, pp. 21-28, vol. 15, *Orthopaedic Surgery Department, University of Kentucky School of Medicine*, Lexington, KY, U.S.A.

Scheffler et al., Biomechanical Comparison of Hamstring and Patellar Tendon Graft Anterior Cruciate Ligament Reconstruction Techniques: The Impact of Fixation Level and Fixation Method Under Cyclic Loading, *Arthroscopy: The Journal of Arthroscopic and Related Surgery*, Mar. 2002, pp. 304-315, vol. 18, No. 3, Arthroscopy Association of North America.

Simonian et al., Interference Screw Position and Hamstring Graft Location for Anterior Cruciate Ligament Reconstruction, *The Journal of Arthroscopic and Related Surgery*, Jul.-Aug. 1998, pp. 459-464, vol. 14, No. 5, The New York Hospital—Cornell University Medical College, New York, U.S.A.

Wolf, Eugene M., Hamstring Anterior Cruciate Ligament, Reconstruction using Femoral Cross-pin Fixation, *Operative Techniques in Sports Medicine*, Oct. 1999, pp. 241-222, vol. 7, No. 4, W.B. Saunders Company, San Francisco, U.S.A.

A Biomechanical Comparison of Femoral RetroScrew Placement in a Porcine Model, *Arthrex Research and Development*, 2007, Arthrex, Inc.

Scope This Out: A Technical Pearls Newsletter for Arthroscopists, Fall 1999, vol. 1, No. 3, Arthrex, Inc, U.S.A.

Scope This Out: A Technical Pearls Newsletter for Arthroscopists, Summer 2001, vol. 3, No. 2, Arthrex, Inc, U.S.A.

Scope This Out: A Technical Pearls Newsletter for Arthroscopists, Summer 2002, vol. 4, No. 2, Arthrex, Inc, U.S.A.

Scope This Out: A Technical Pearls Newsletter for Arthroscopists, Summer 2002, vol. 5, No. 2, Arthrex, Inc, U.S.A.

European Search Report dated Feb. 9, 2012 in related European Patent Application No. EP 07871231.

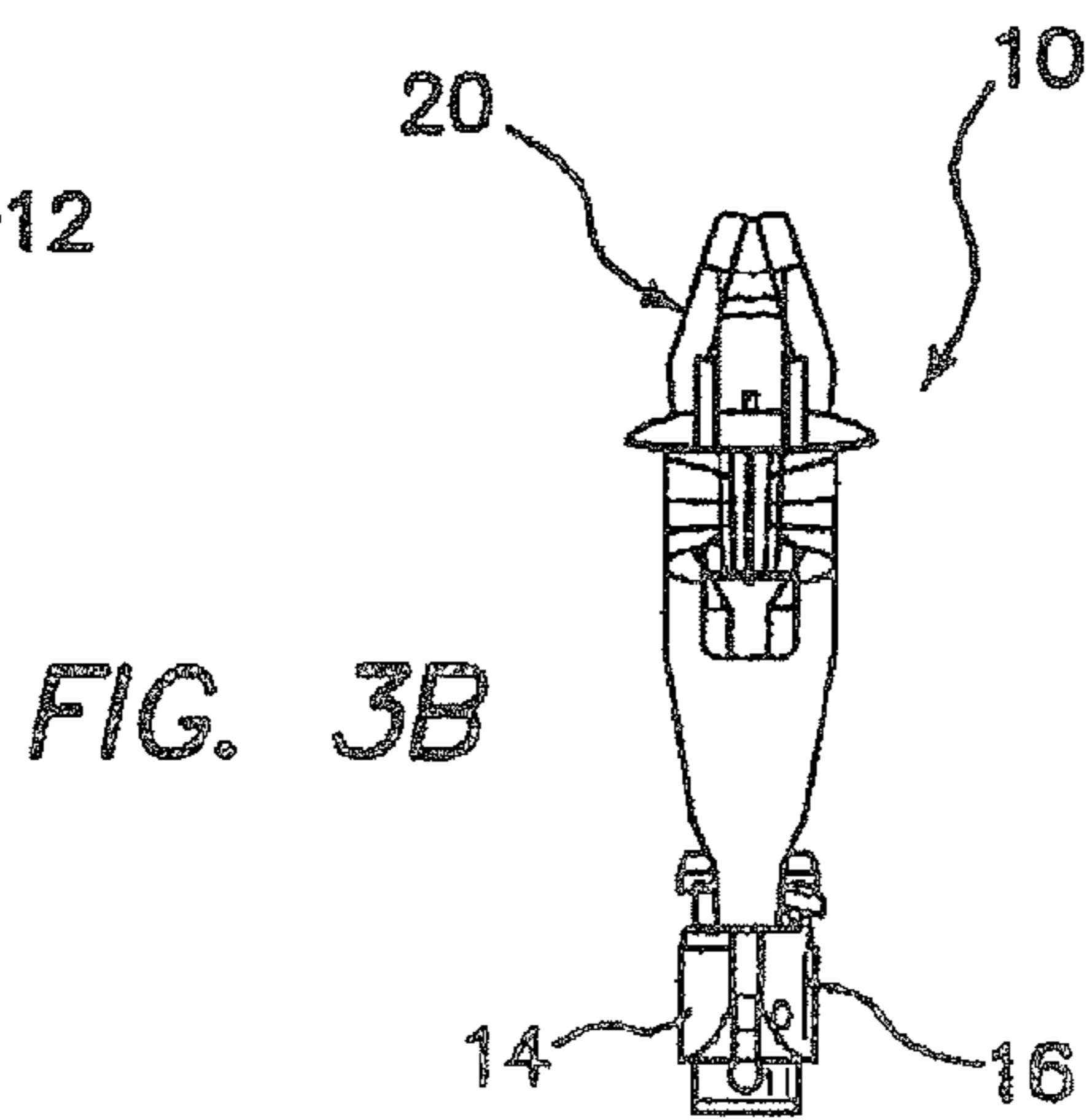
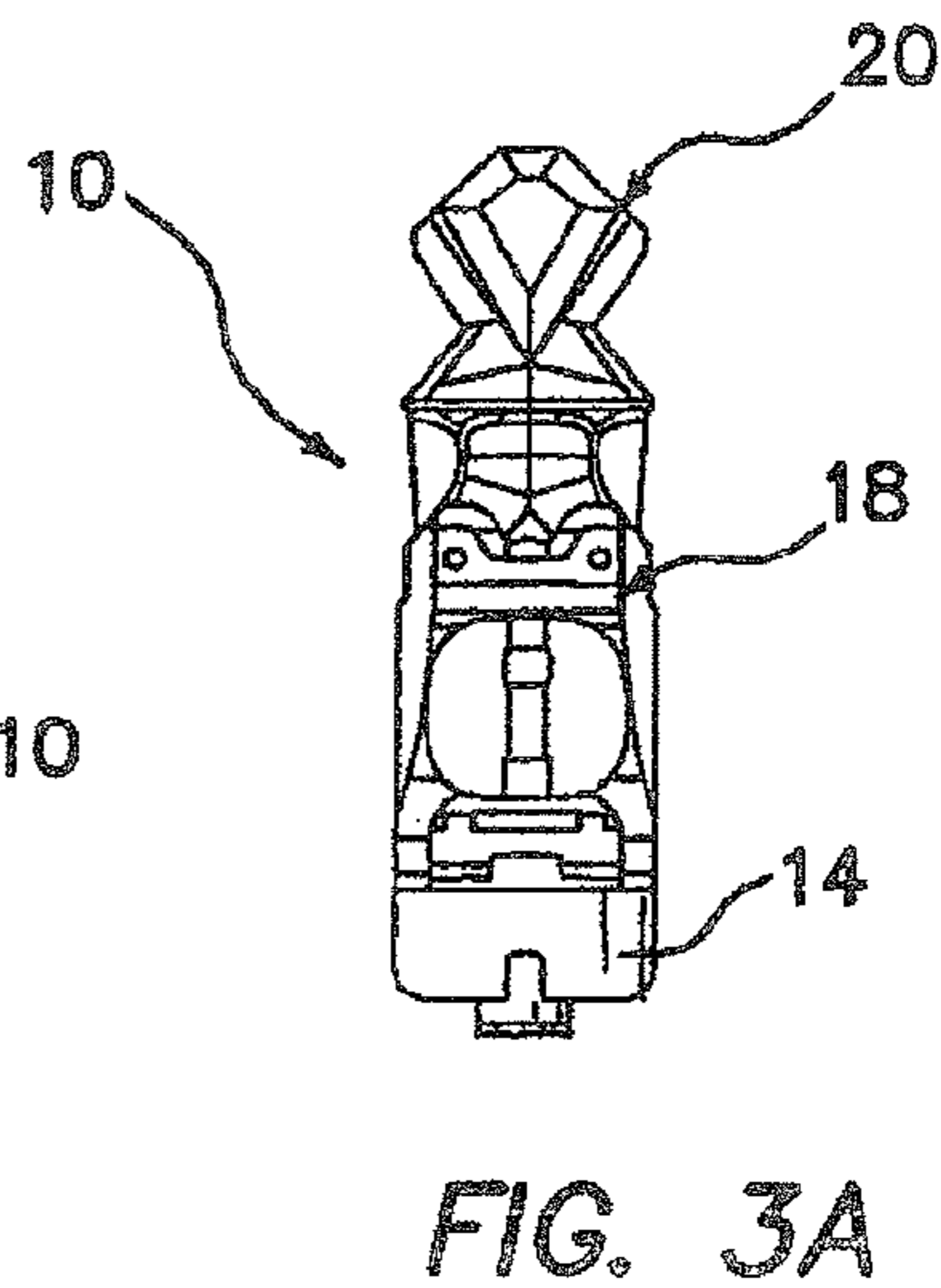
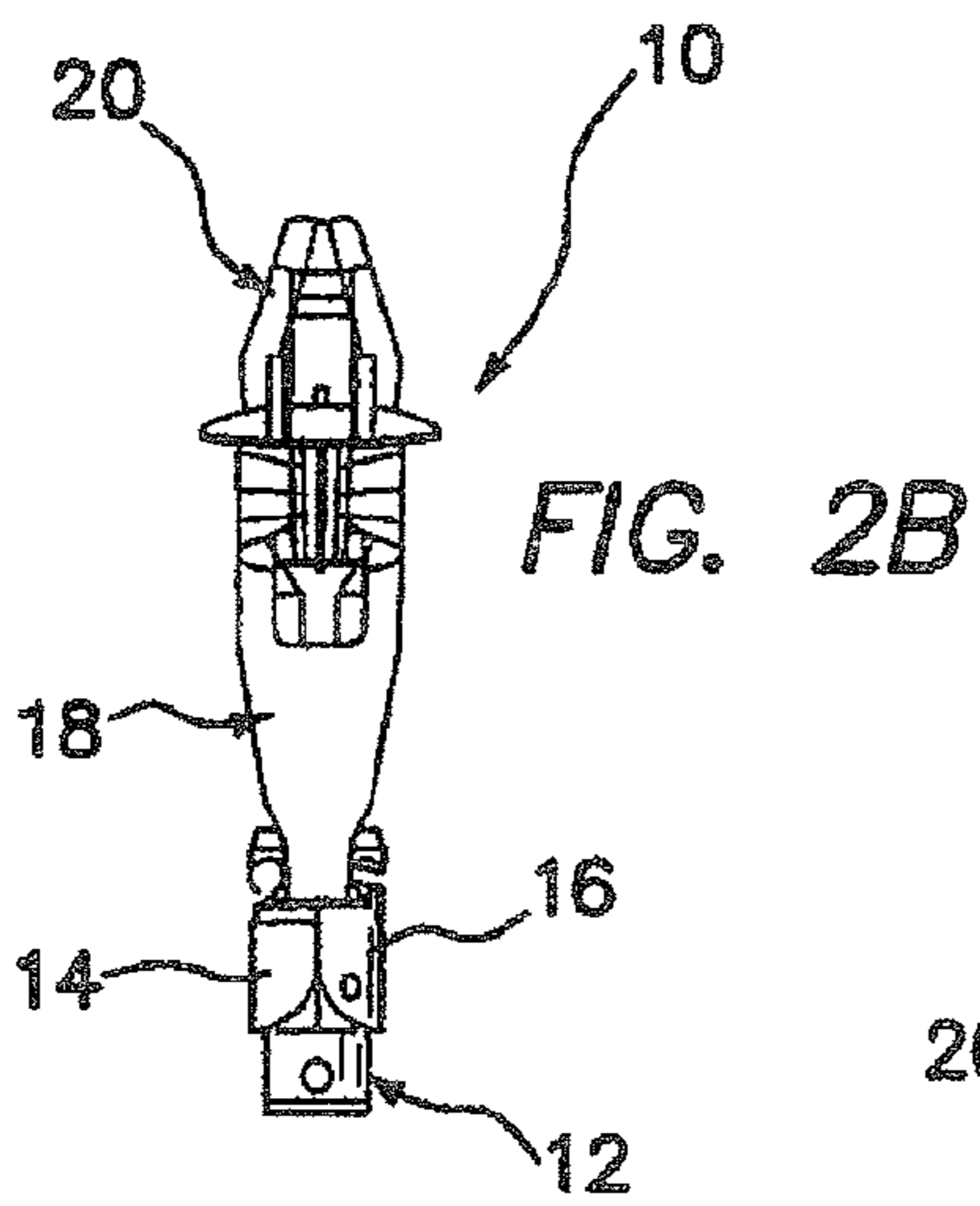
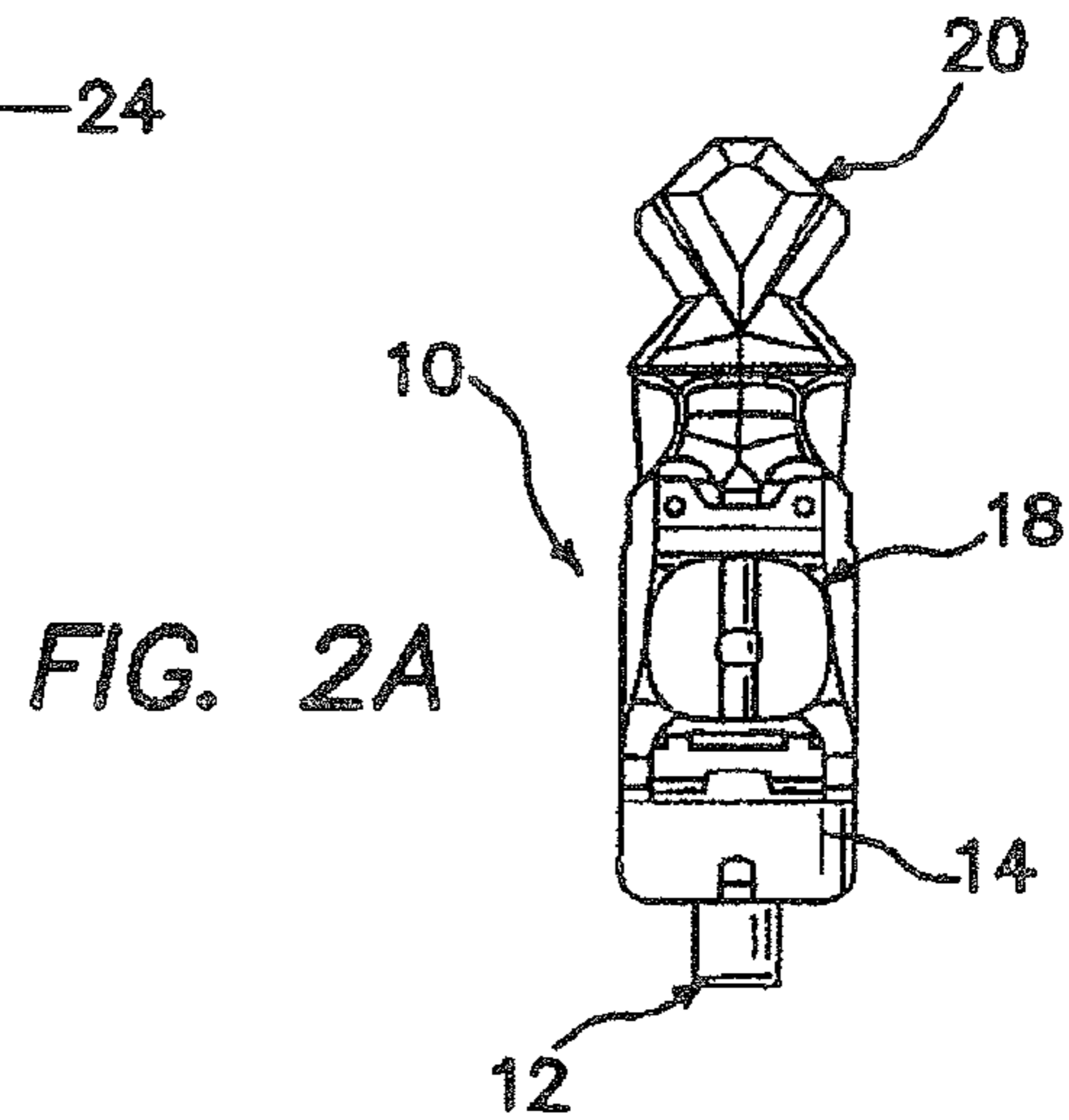
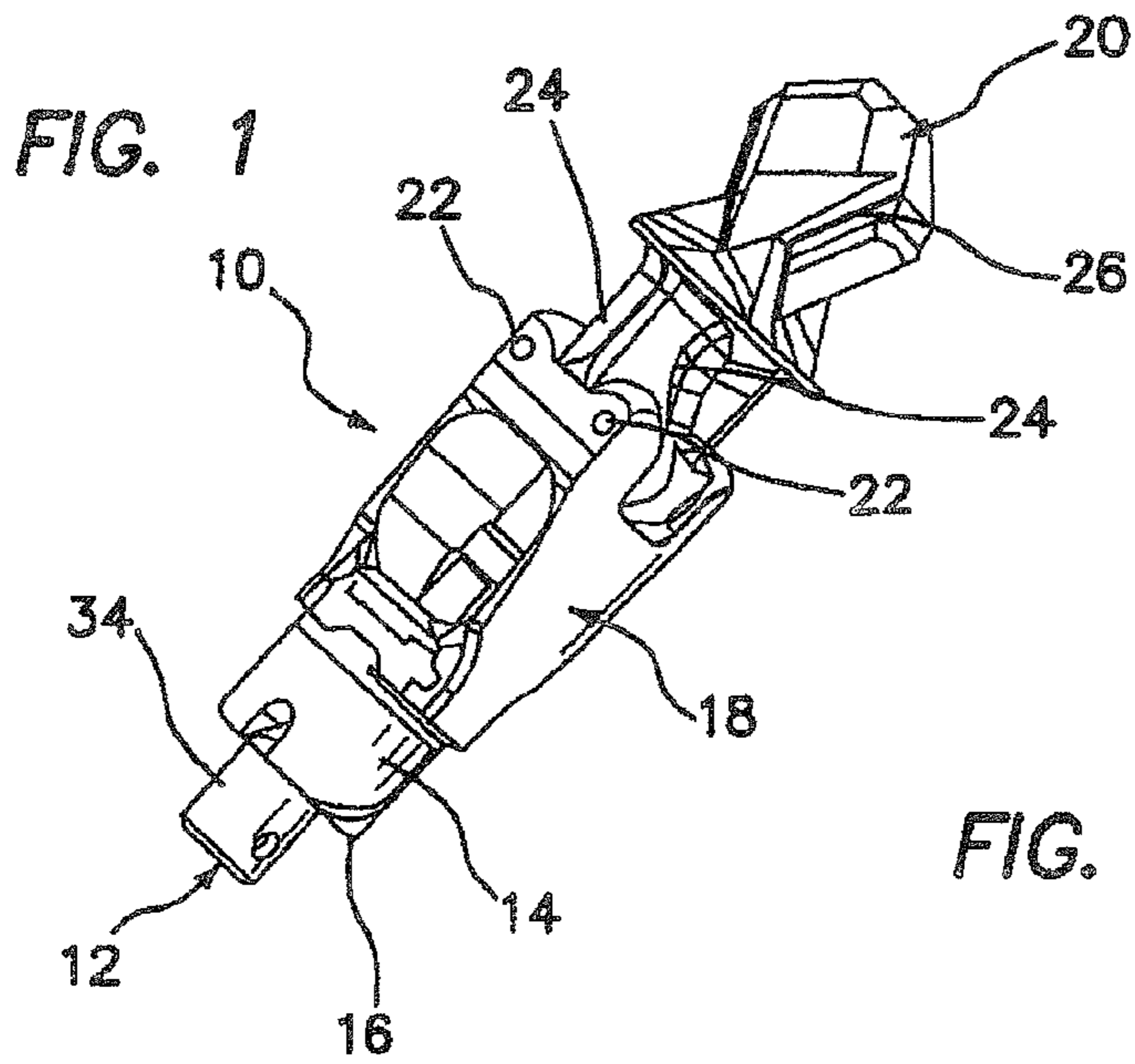

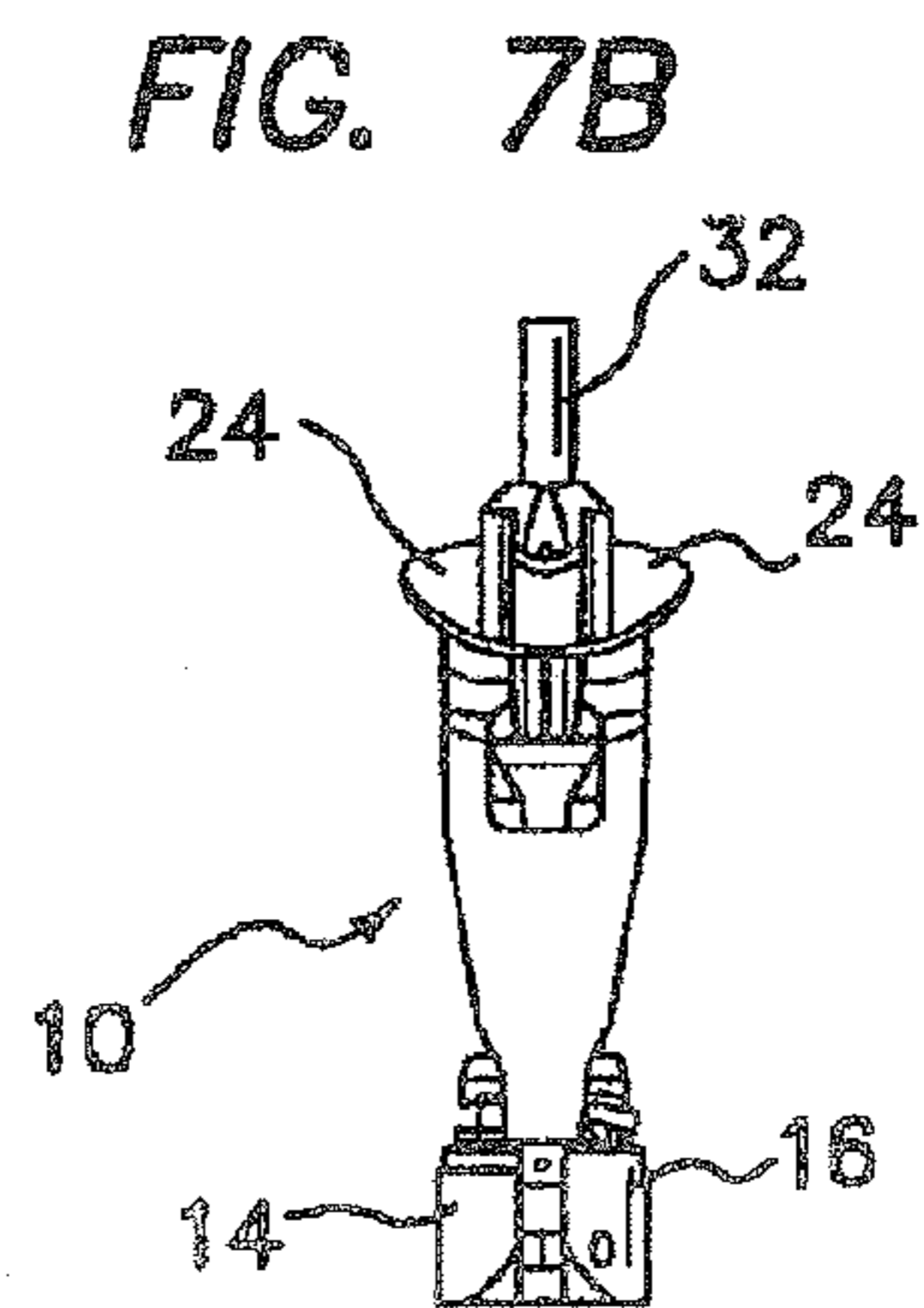
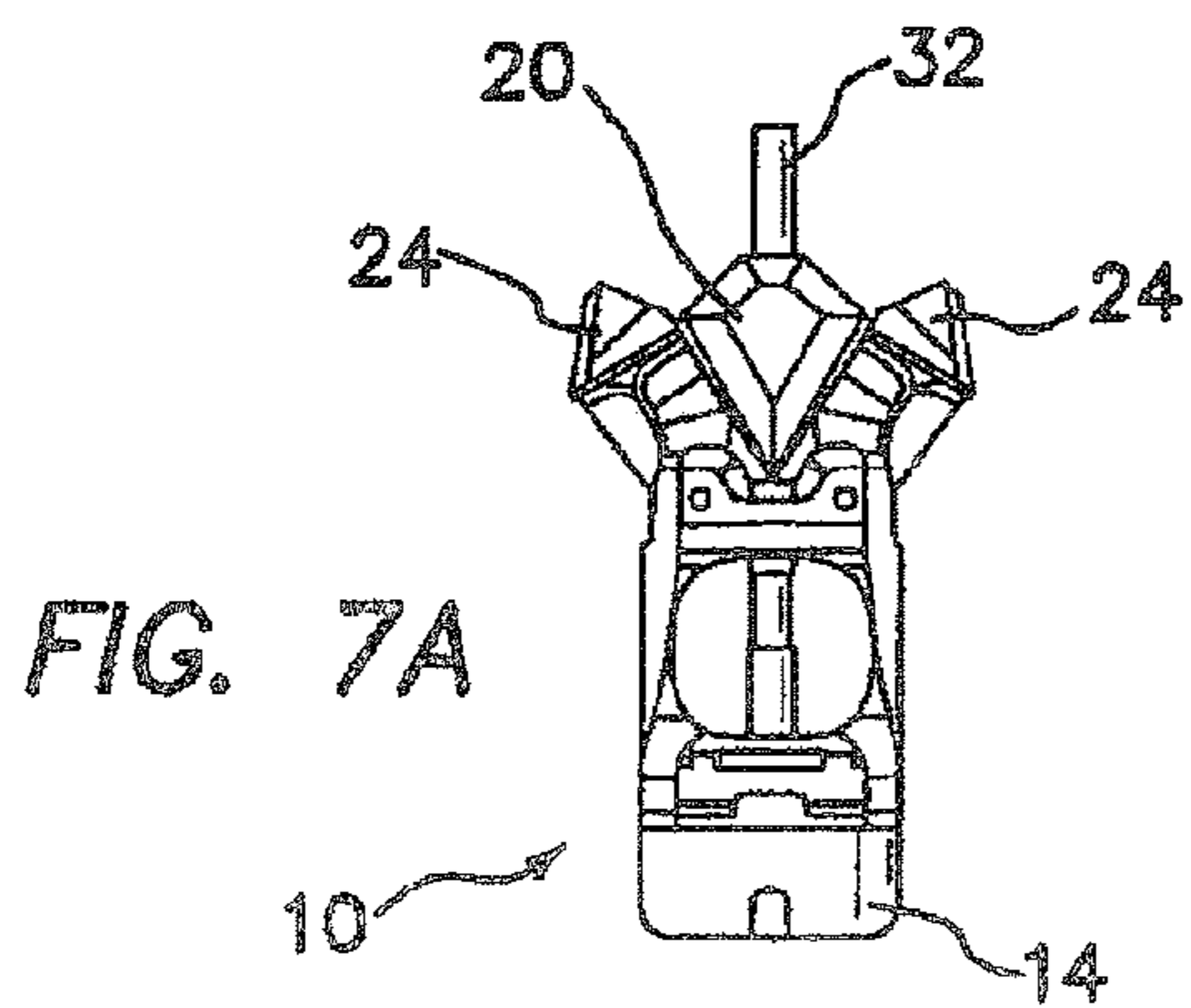
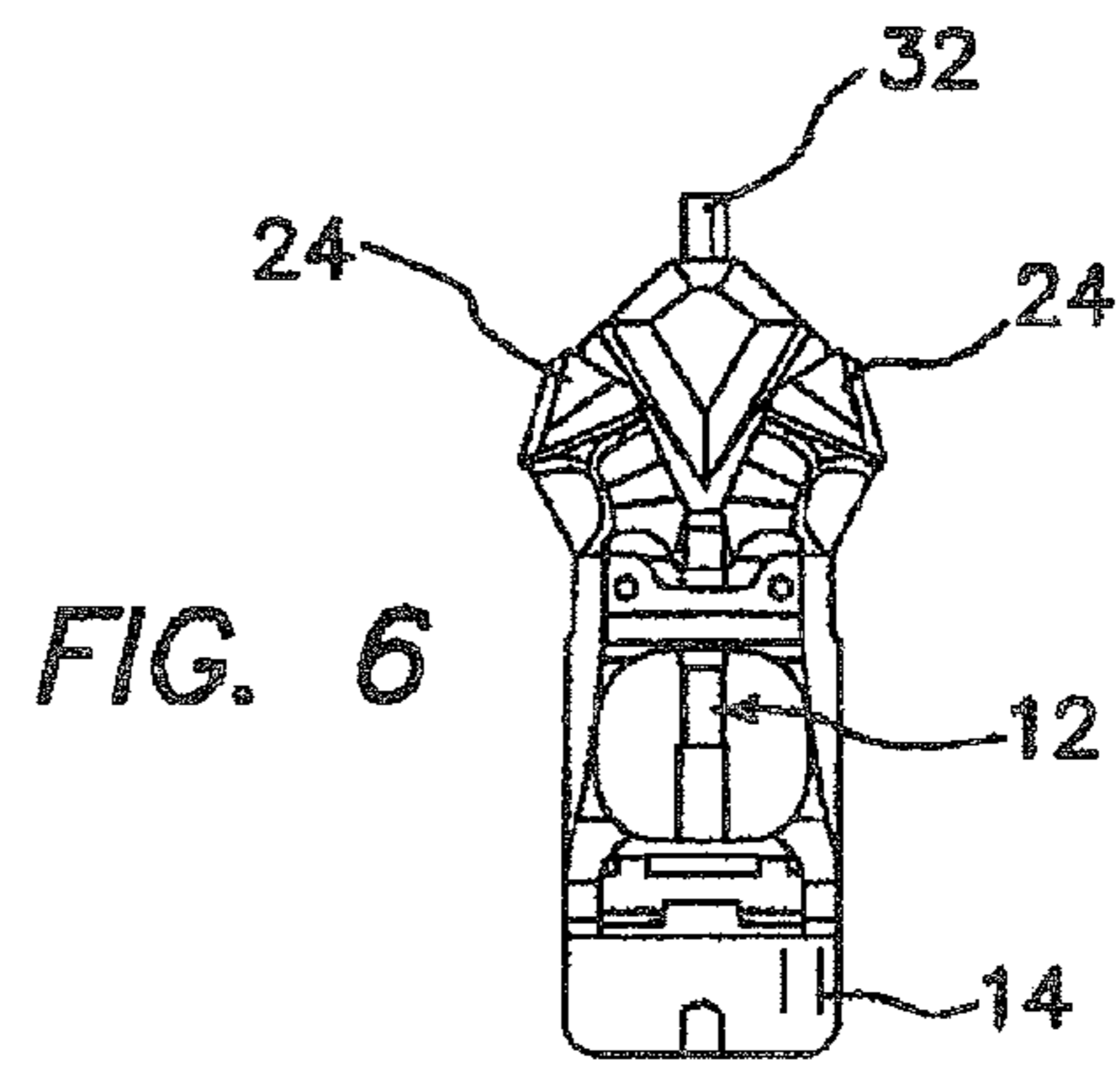
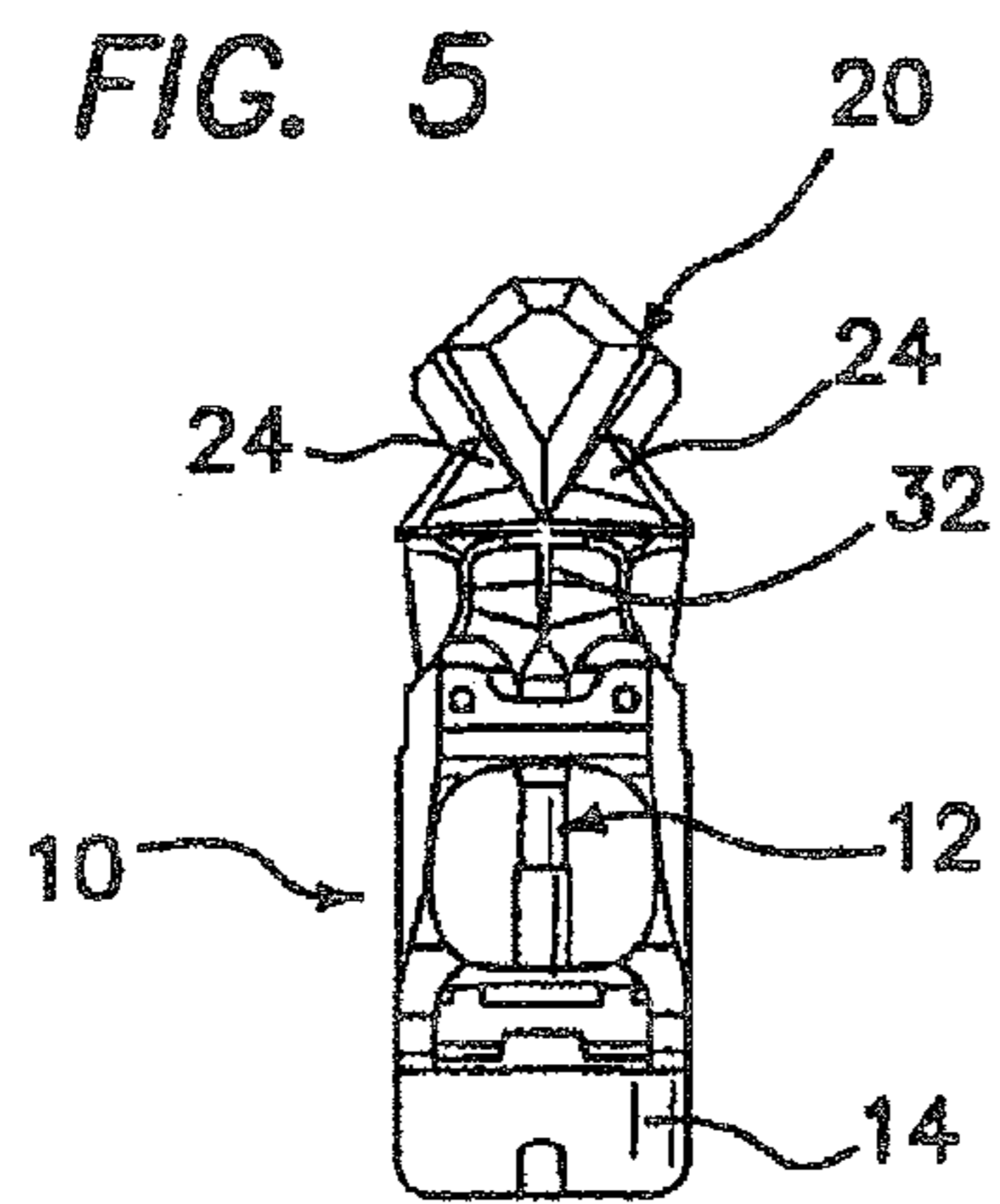
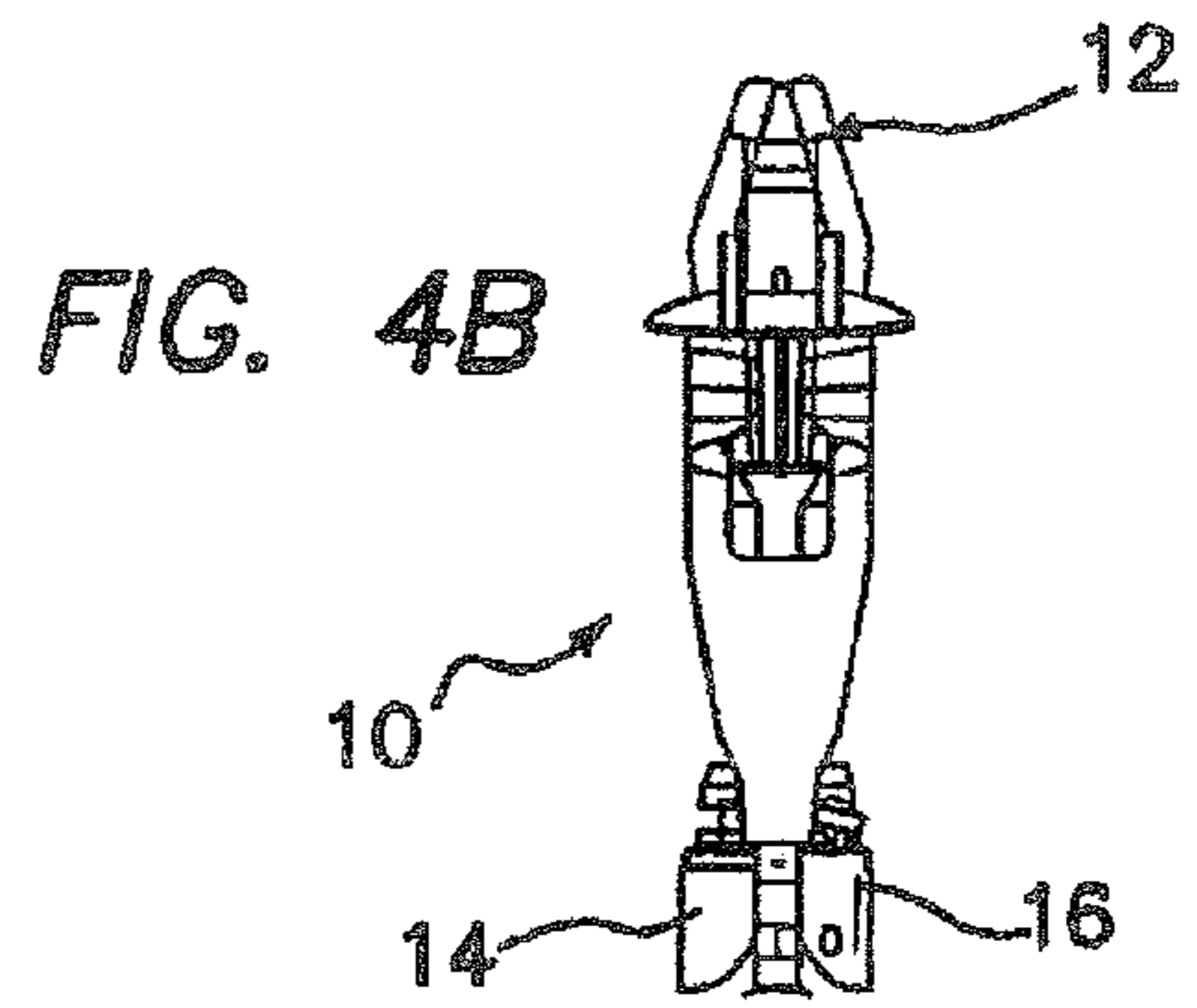
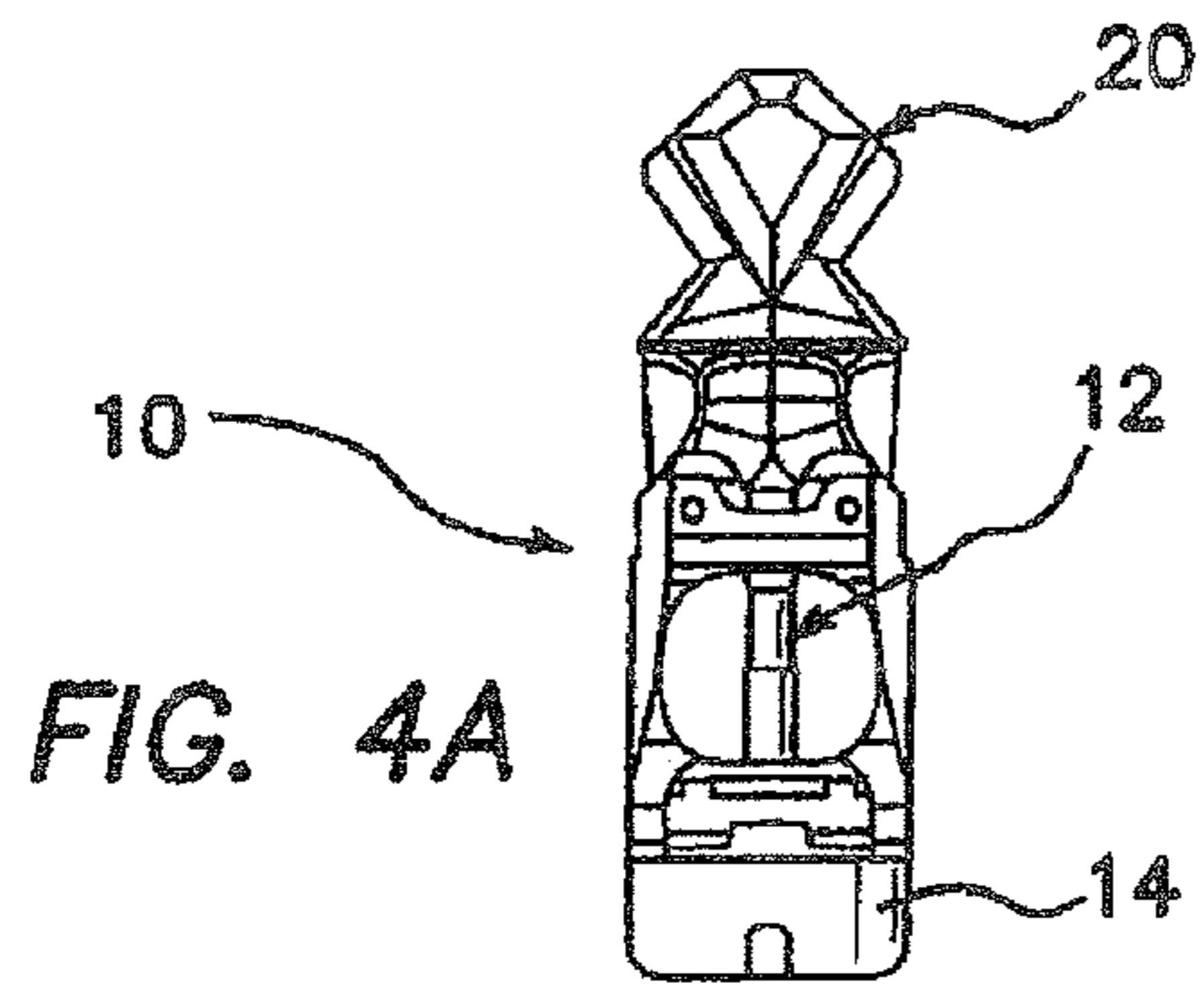

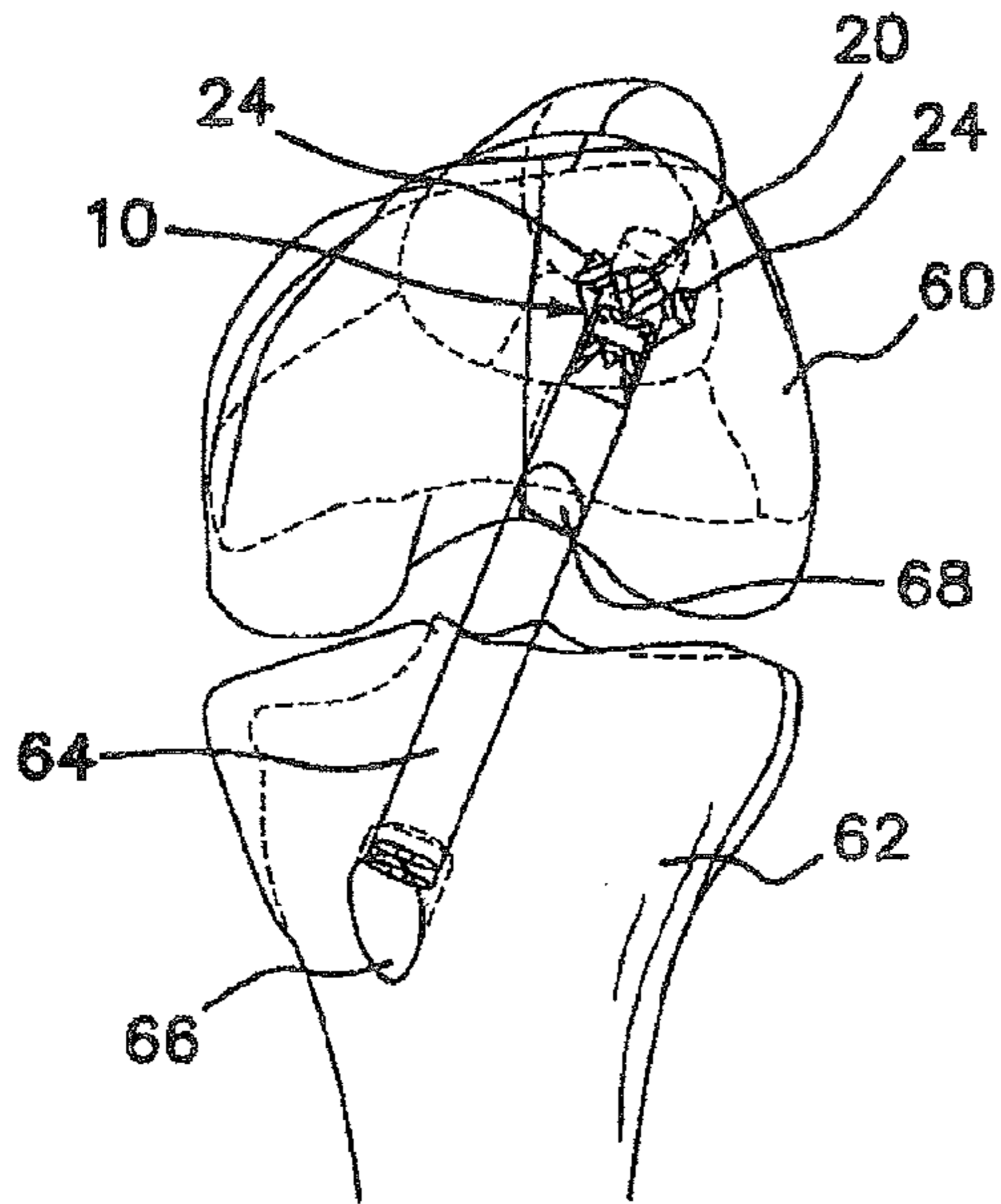

FIG. 8

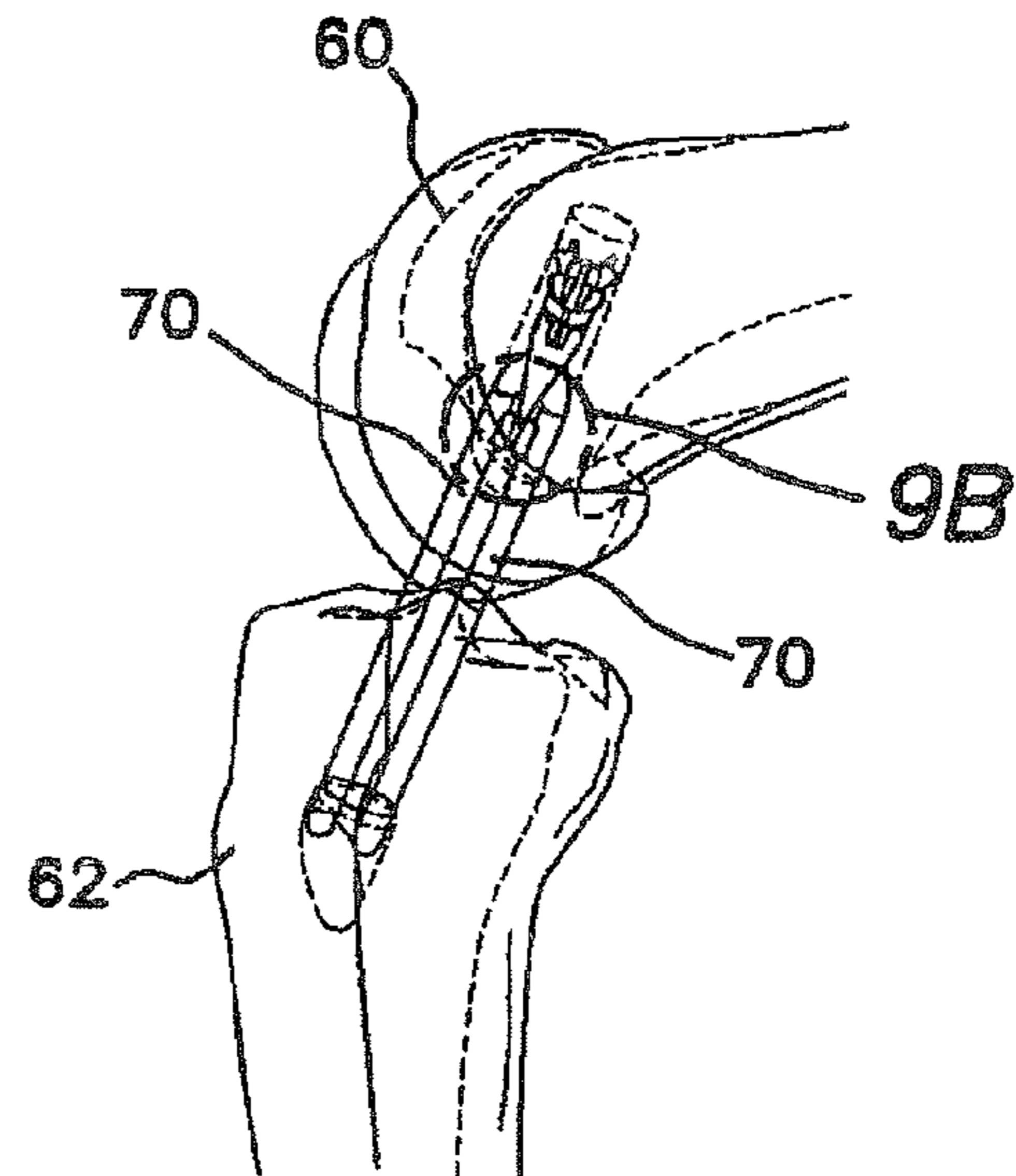

FIG. 9A

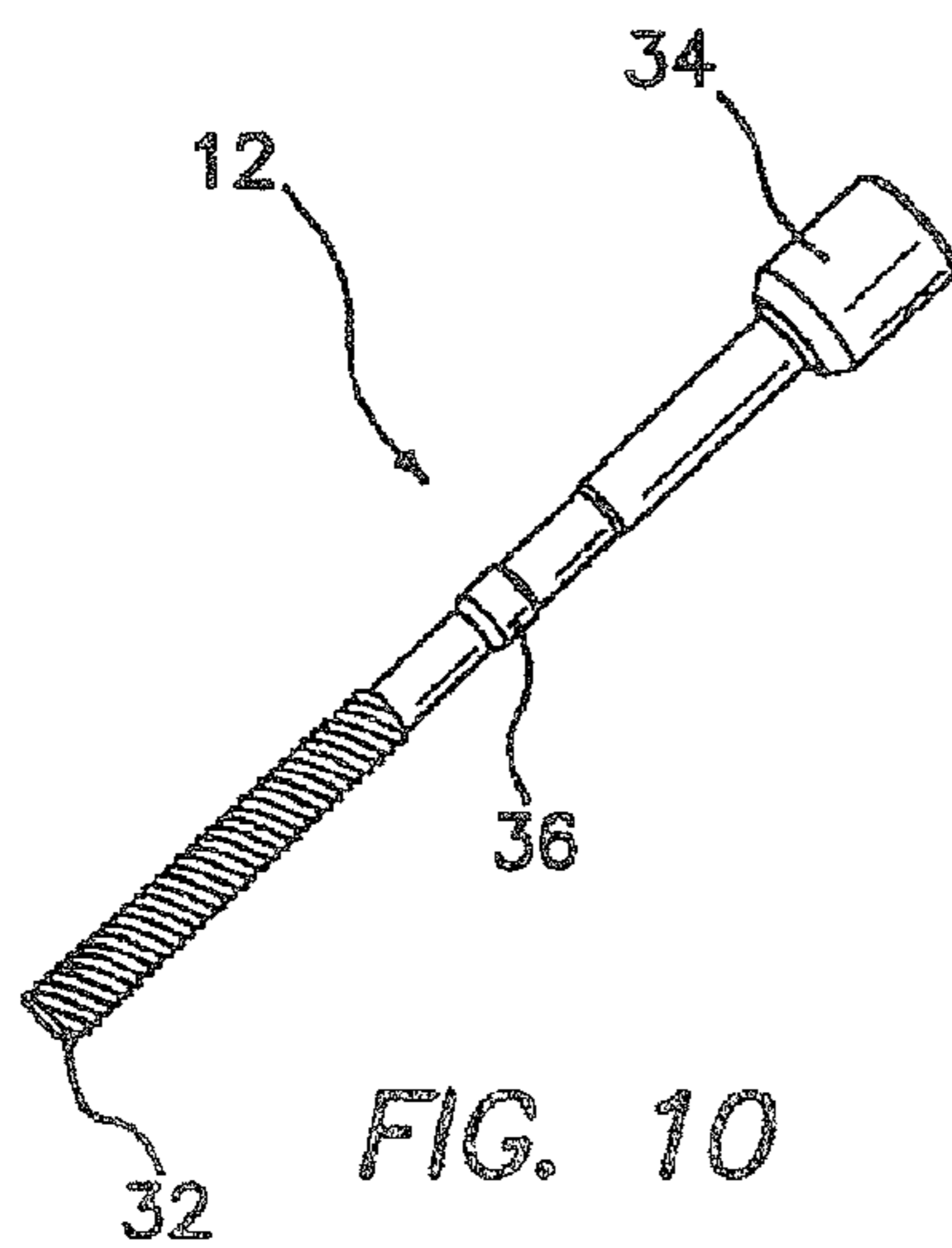

FIG. 10

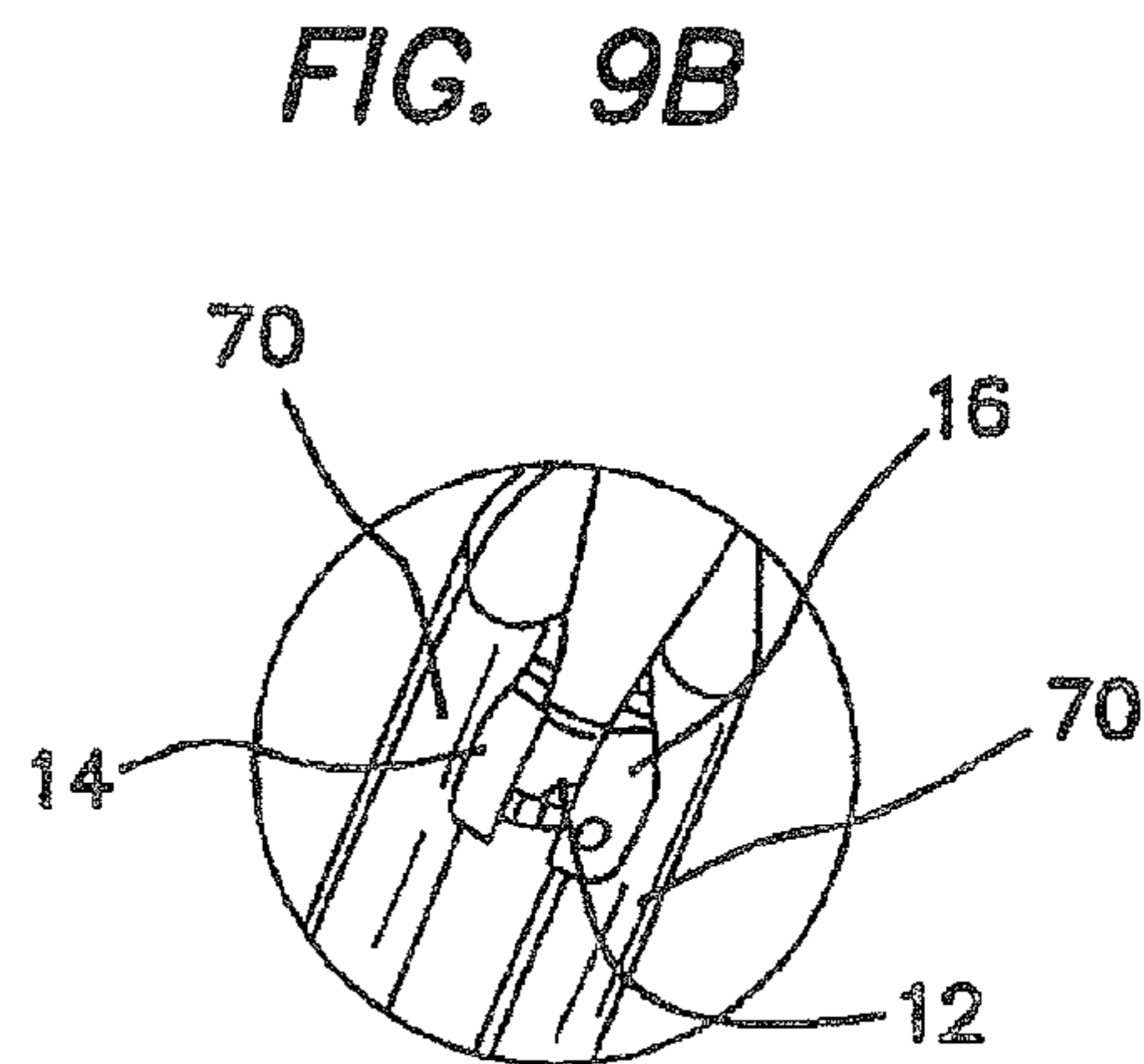

FIG. 9B

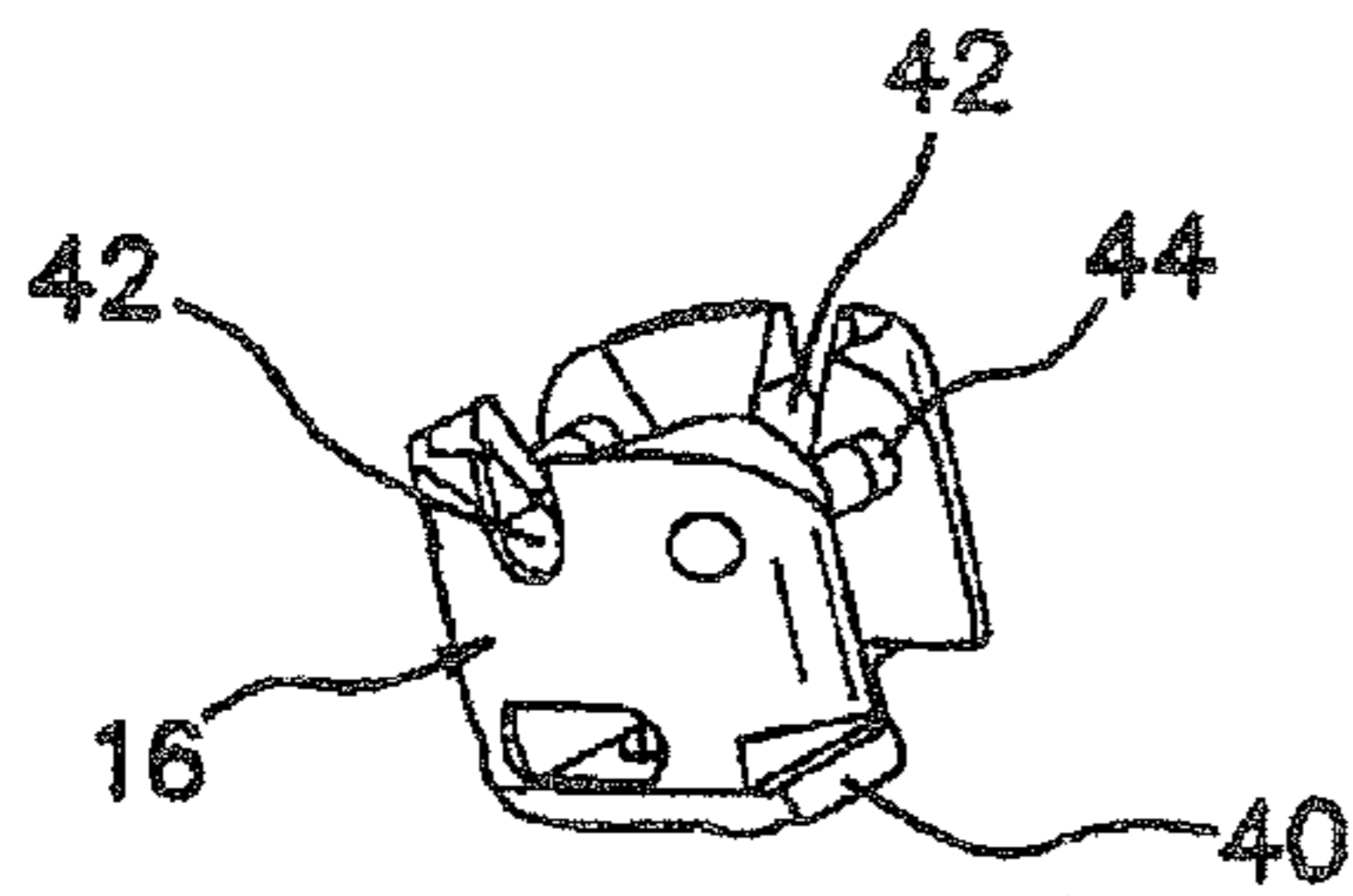

FIG. 11A

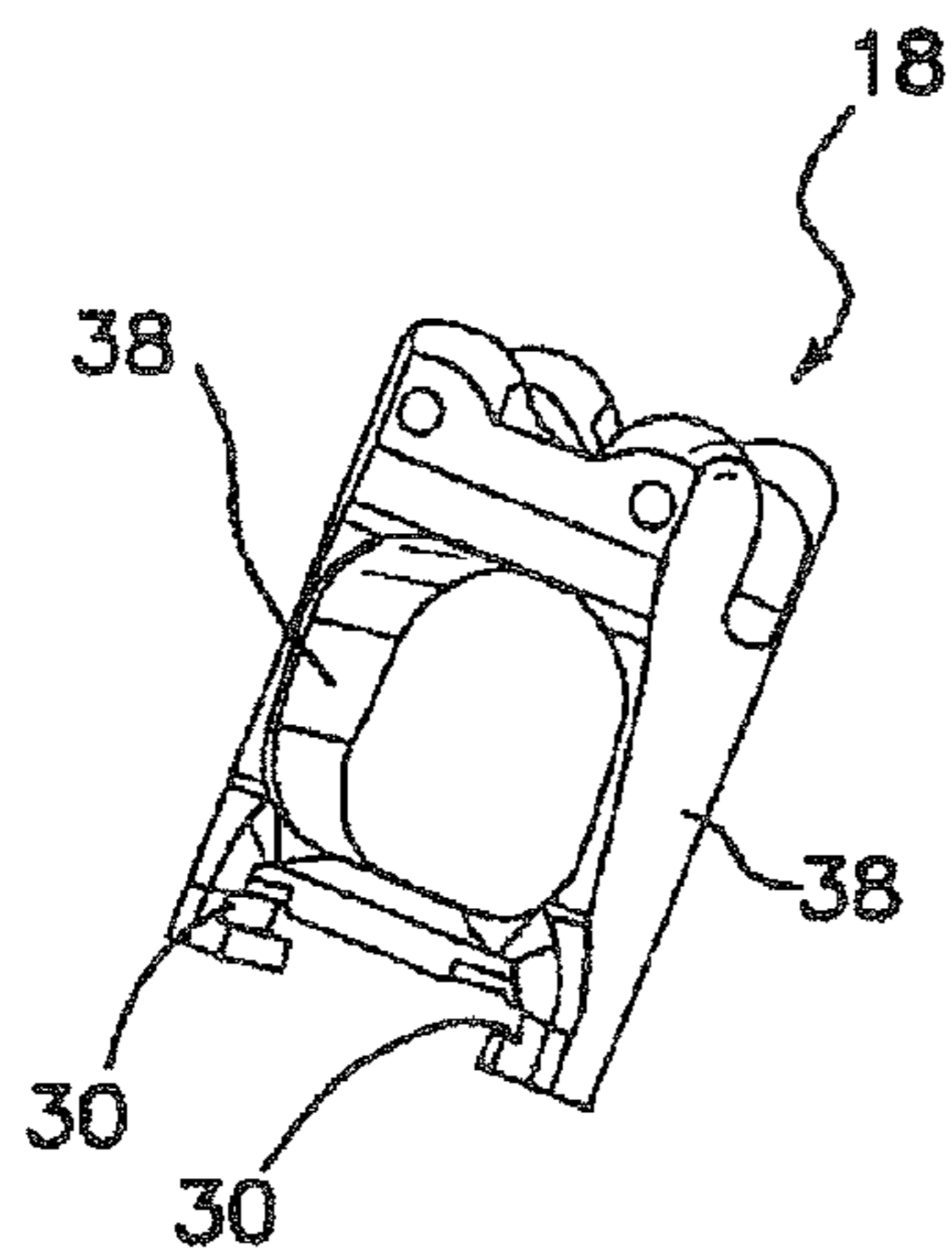
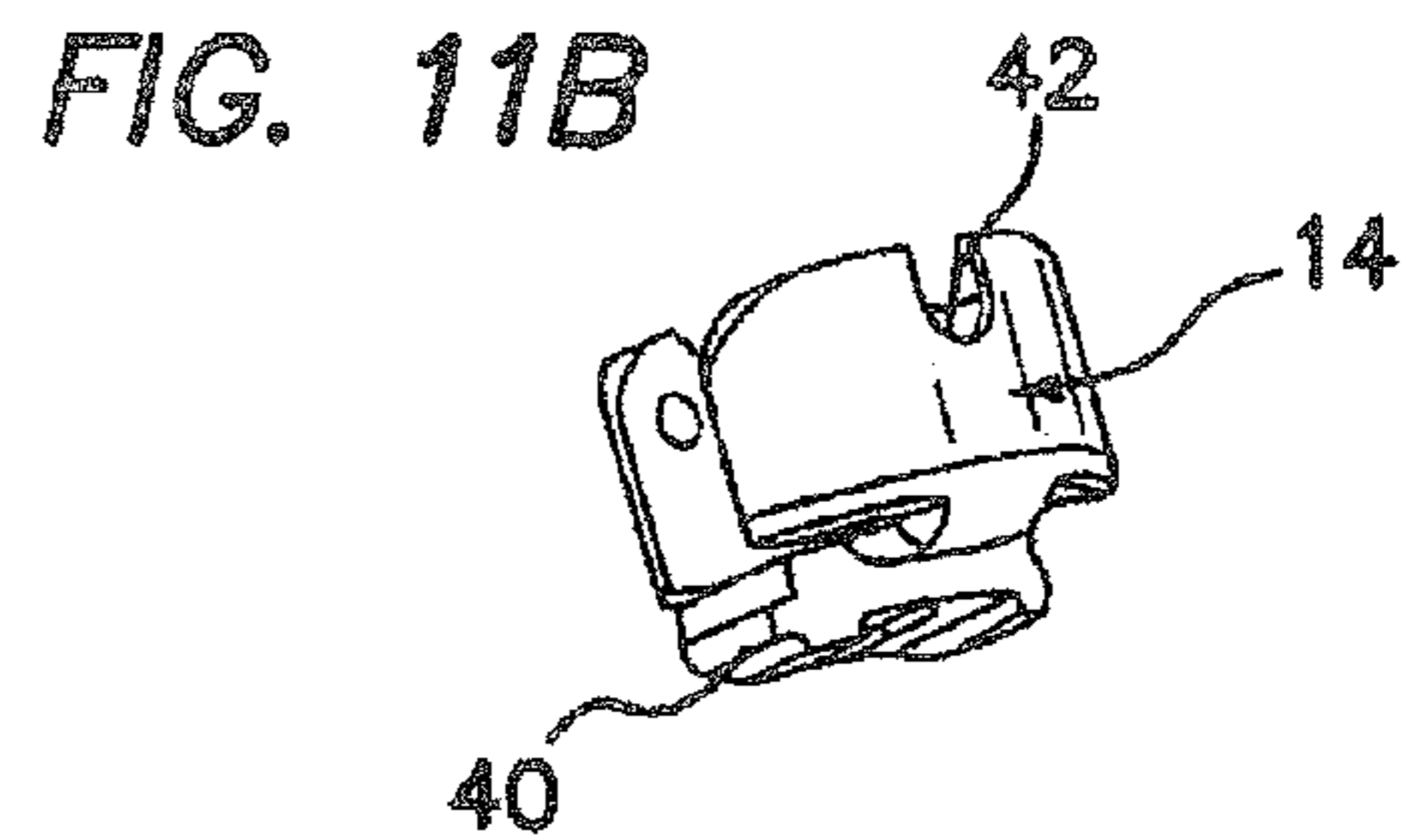

FIG. 12

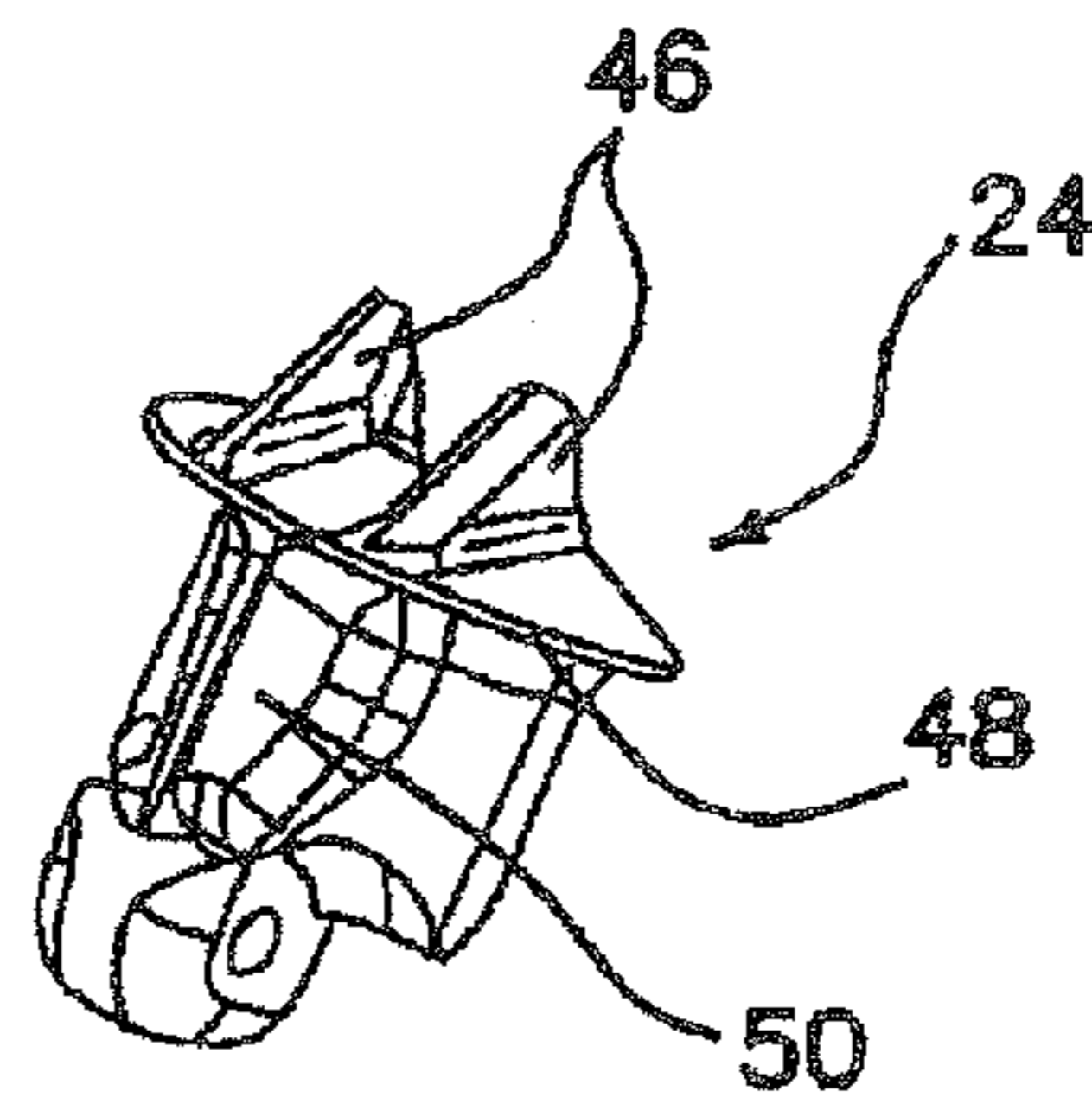

FIG. 13A

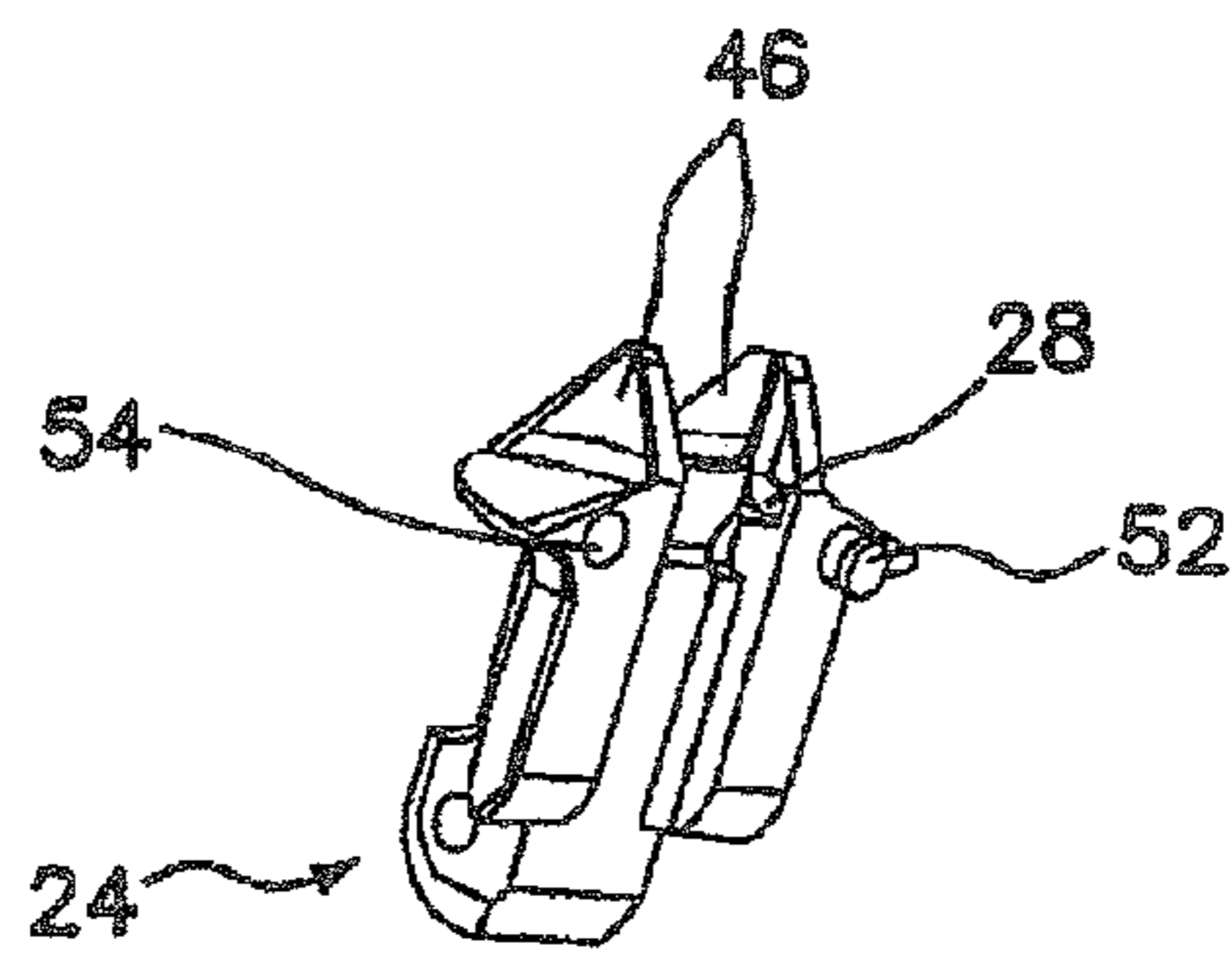

FIG. 13B

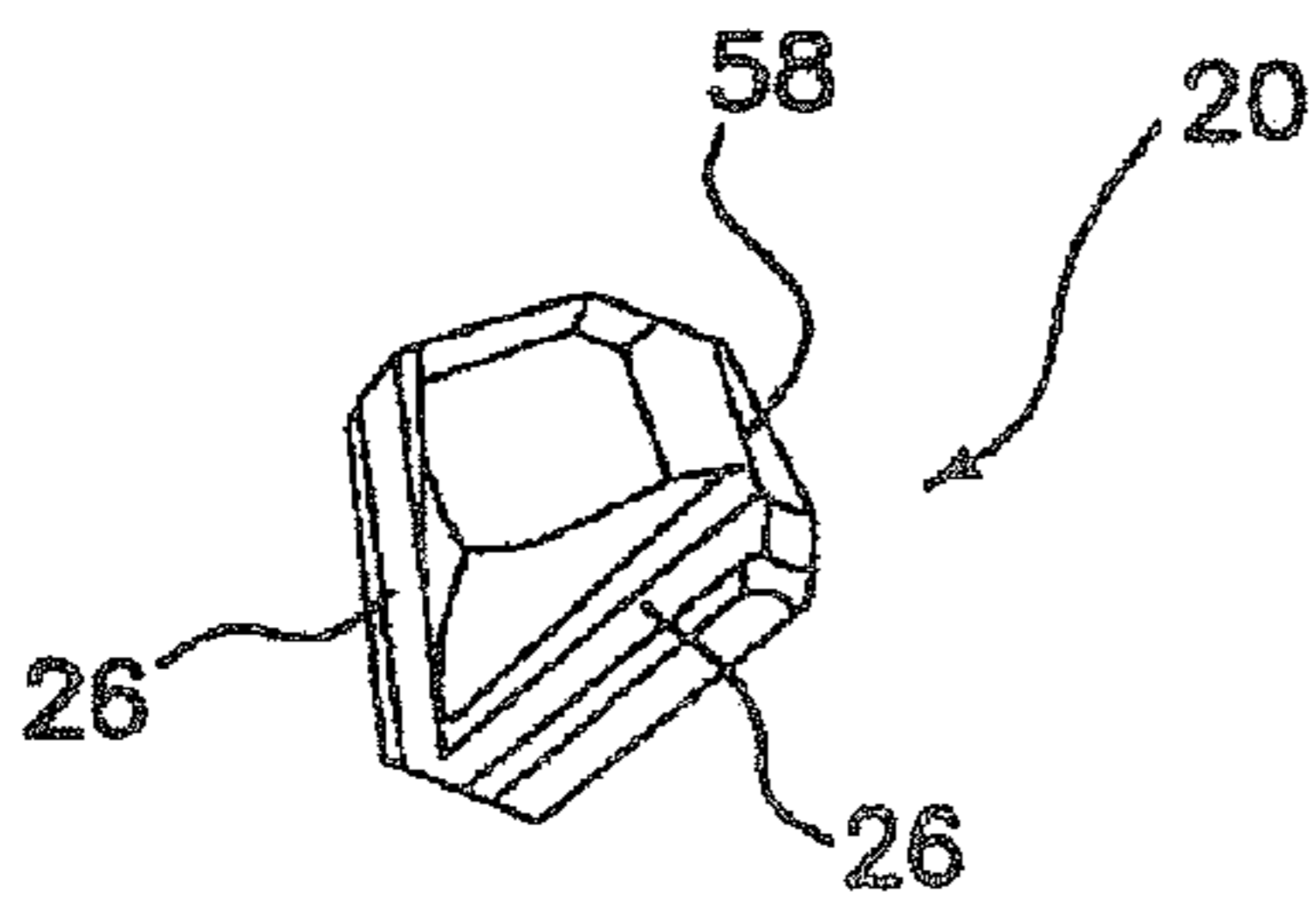

FIG. 14A

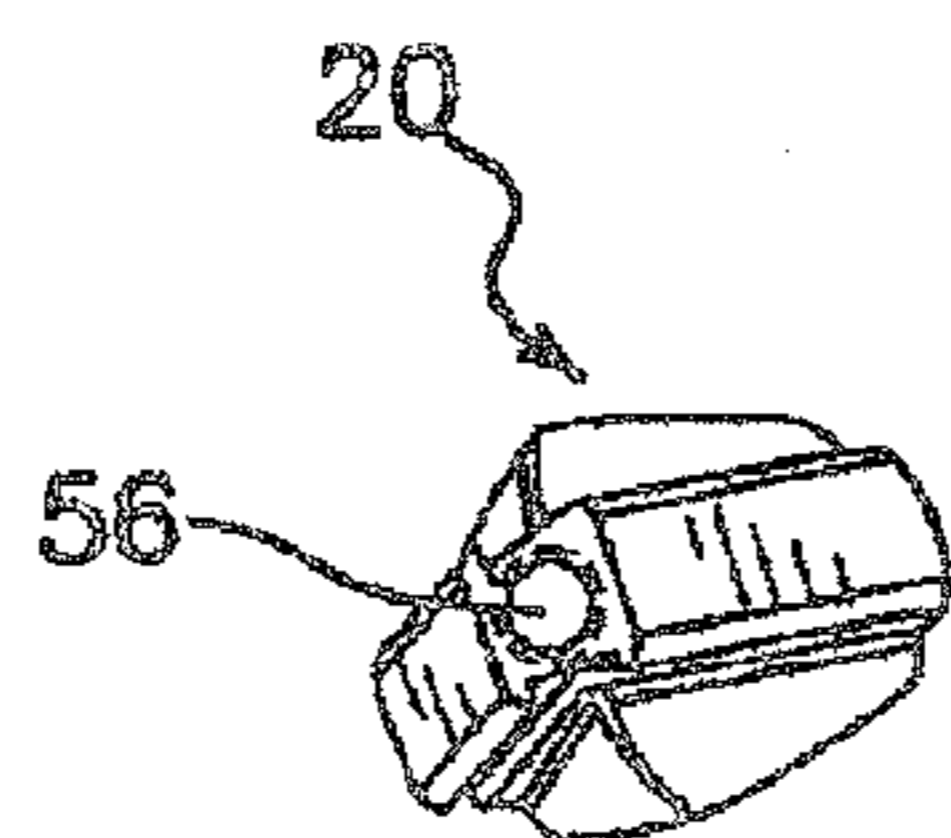

FIG. 14B

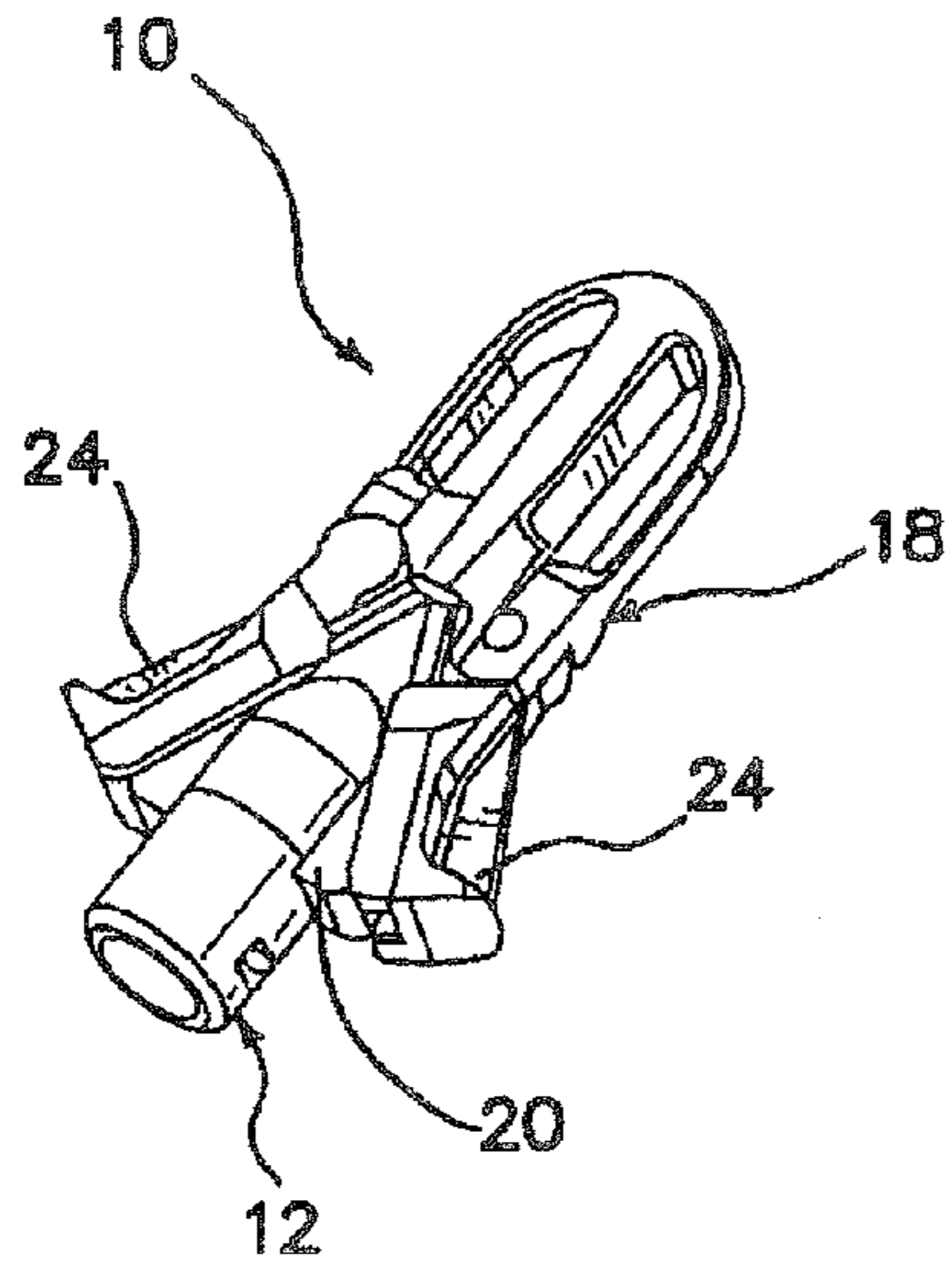

FIG. 15A

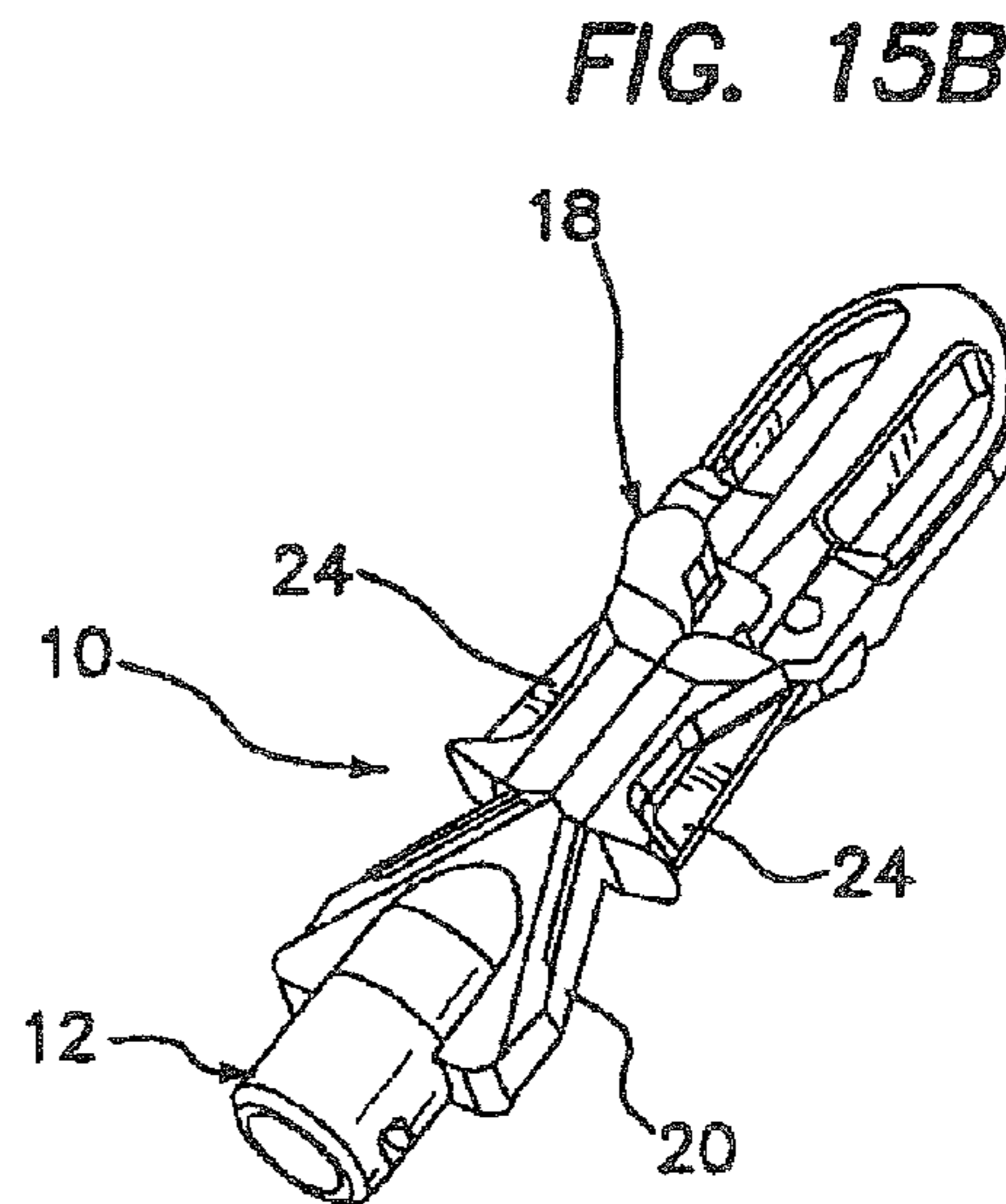

FIG. 15B

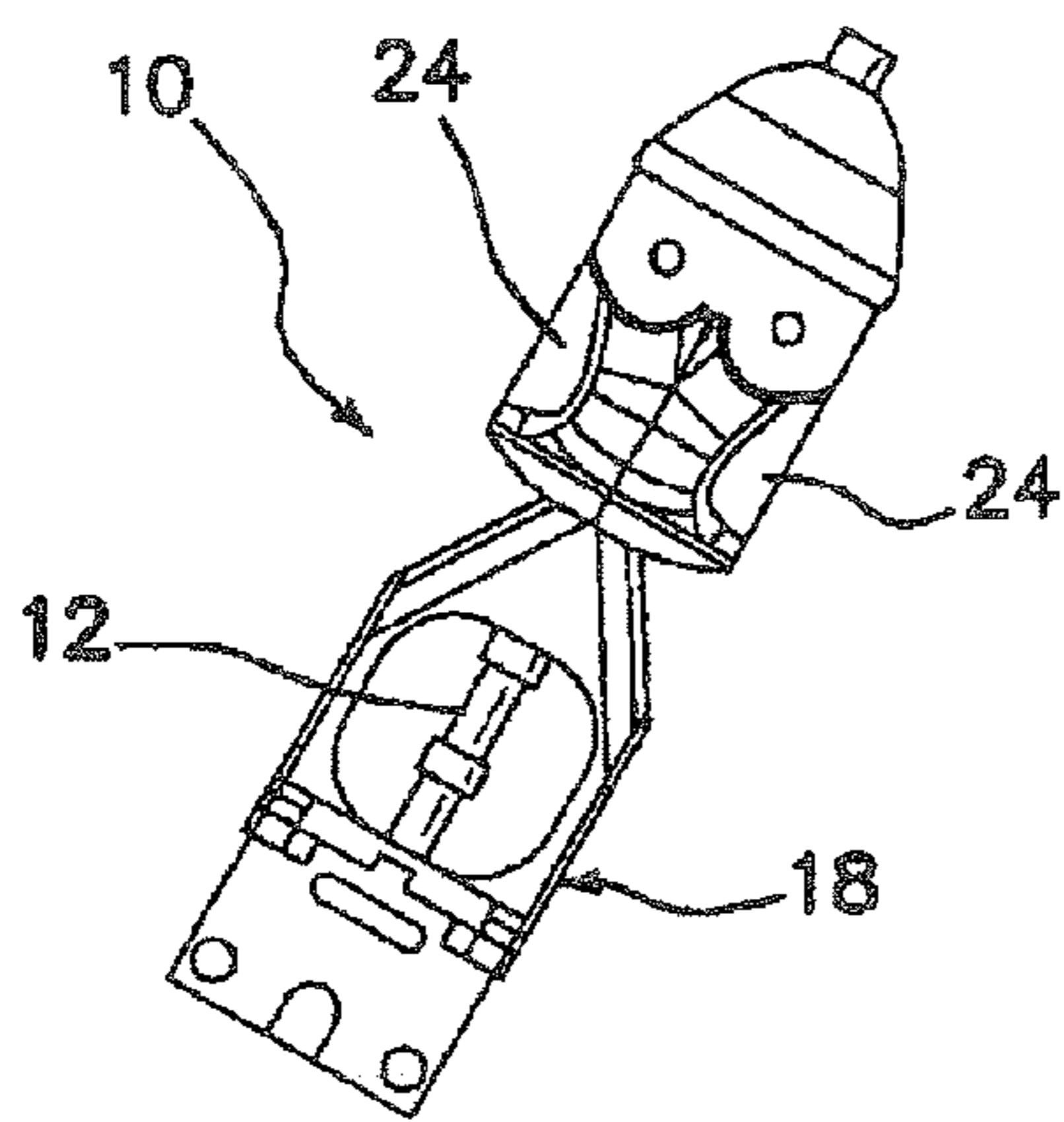

FIG. 16A

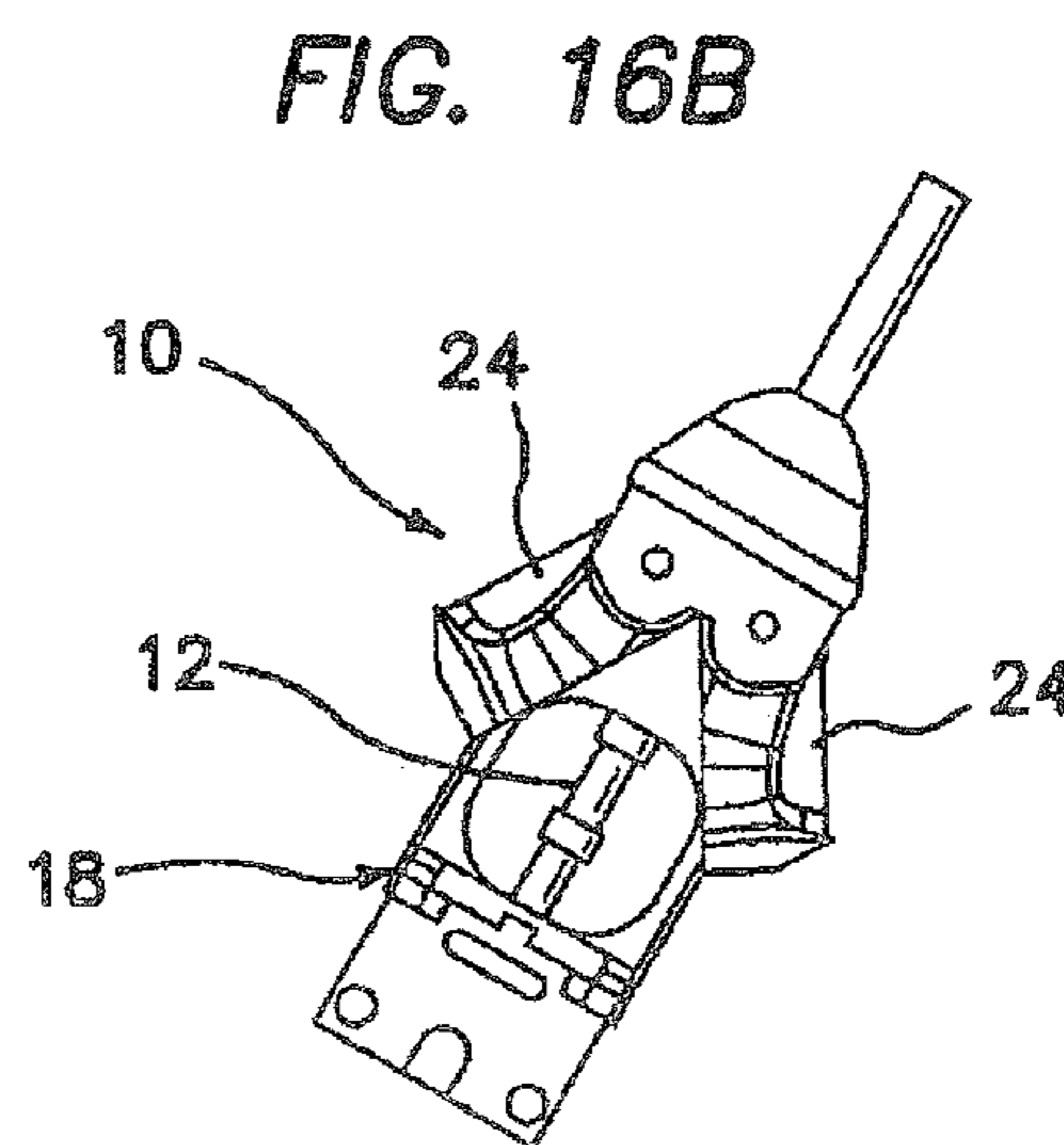

FIG. 16B

		Pull out Forces (N)
Implants	Mean	1253
	Standard Deviation	142.5
	Minimum Value	938.3
	Maximum value	1567.9
		Pull out Forces (N)
RCI Screws	Mean	532.7
	Standard Deviation	349.7
	Minimum Value	135.7
	Maximum value	1230.9

FIG. 17

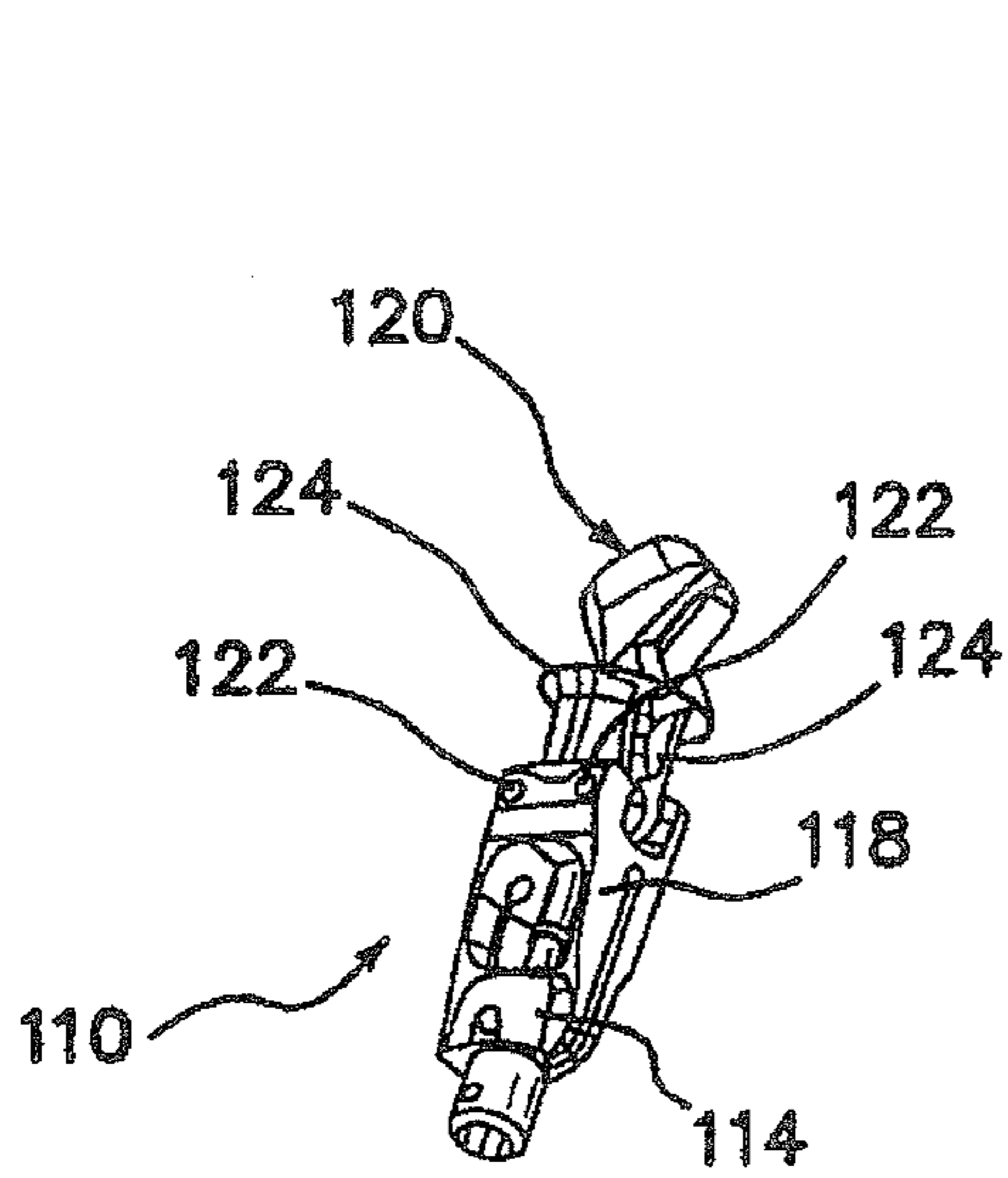

FIG. 18

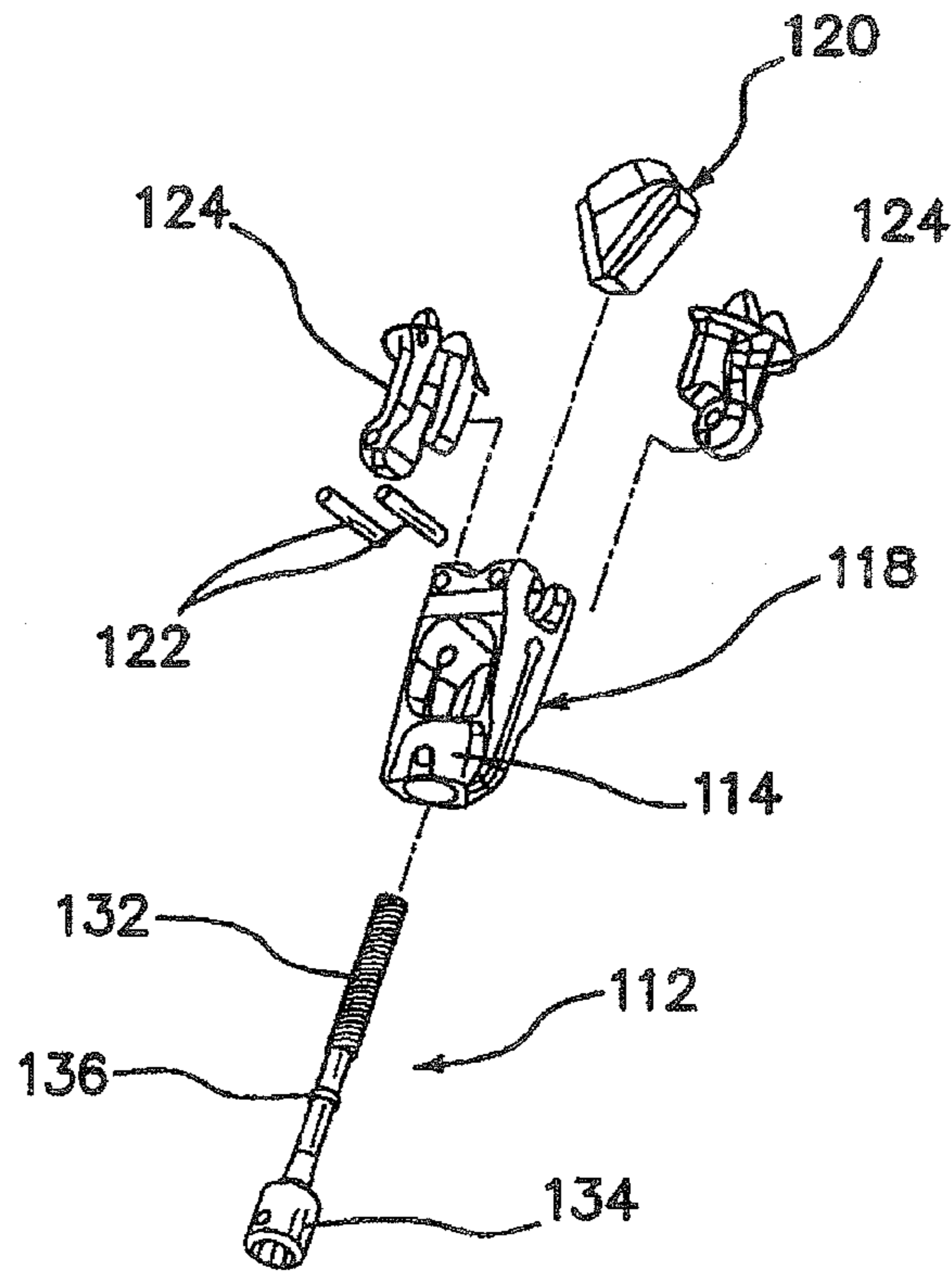

FIG. 19

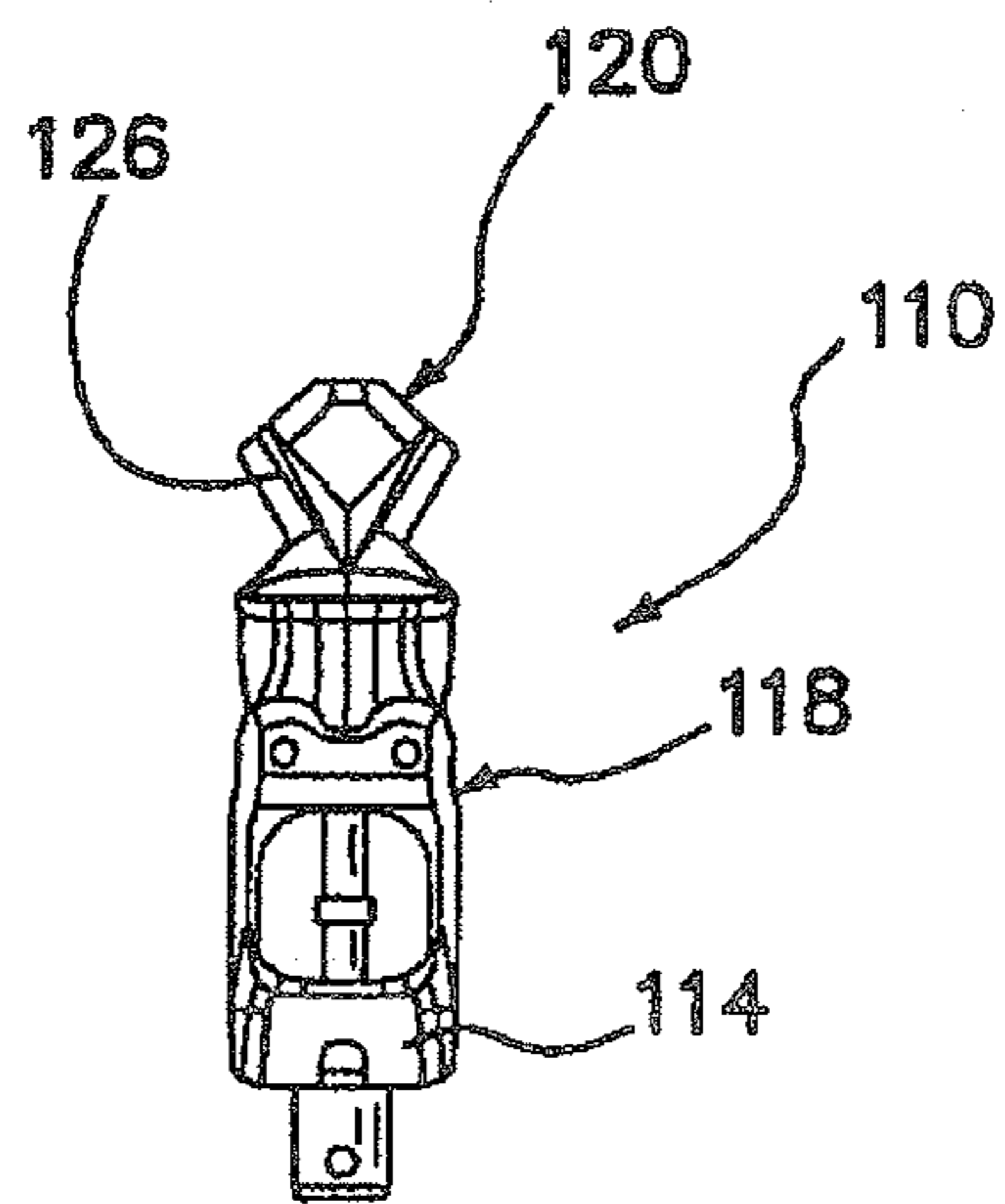

FIG. 20

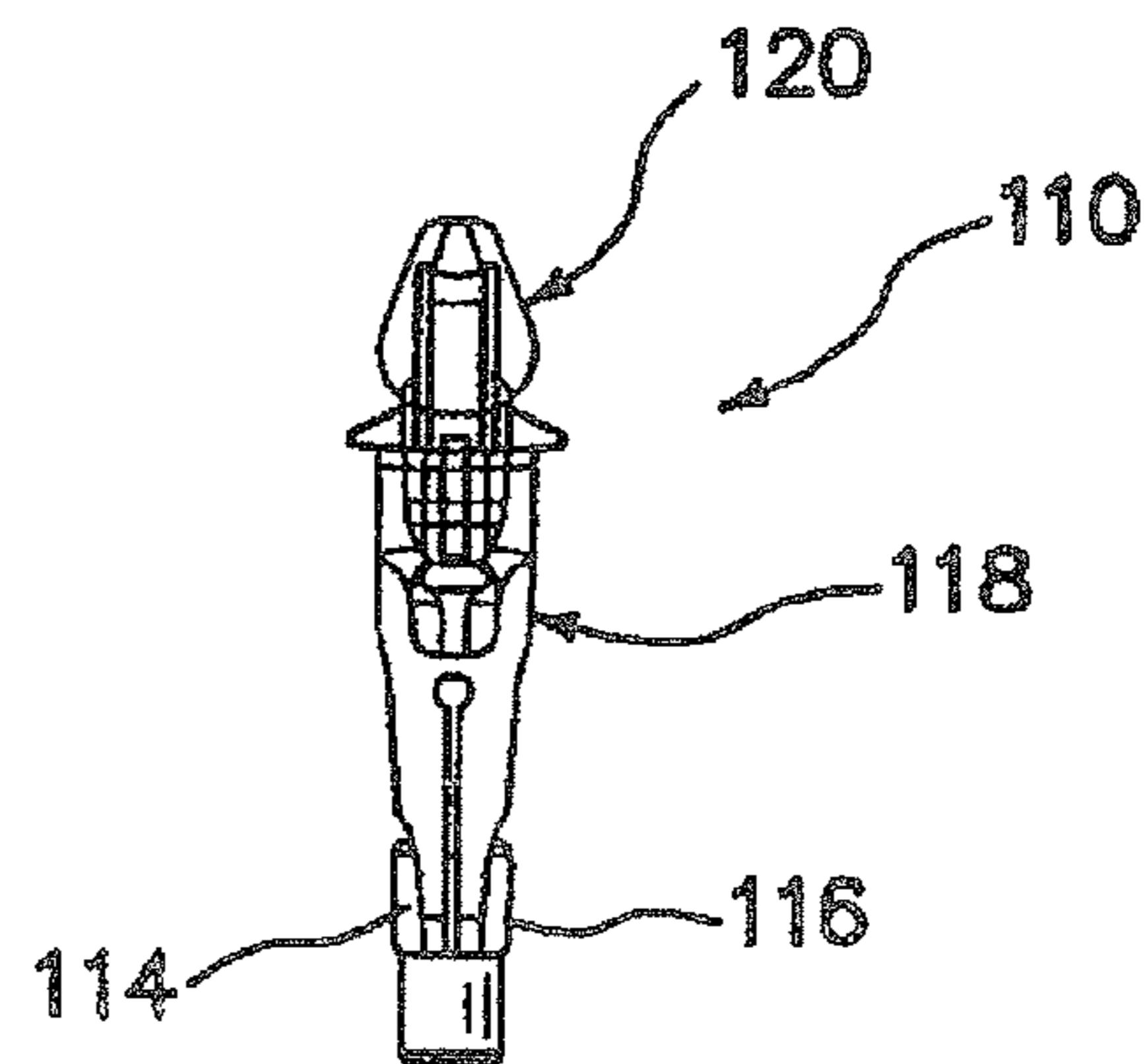

FIG. 21

FIG. 23

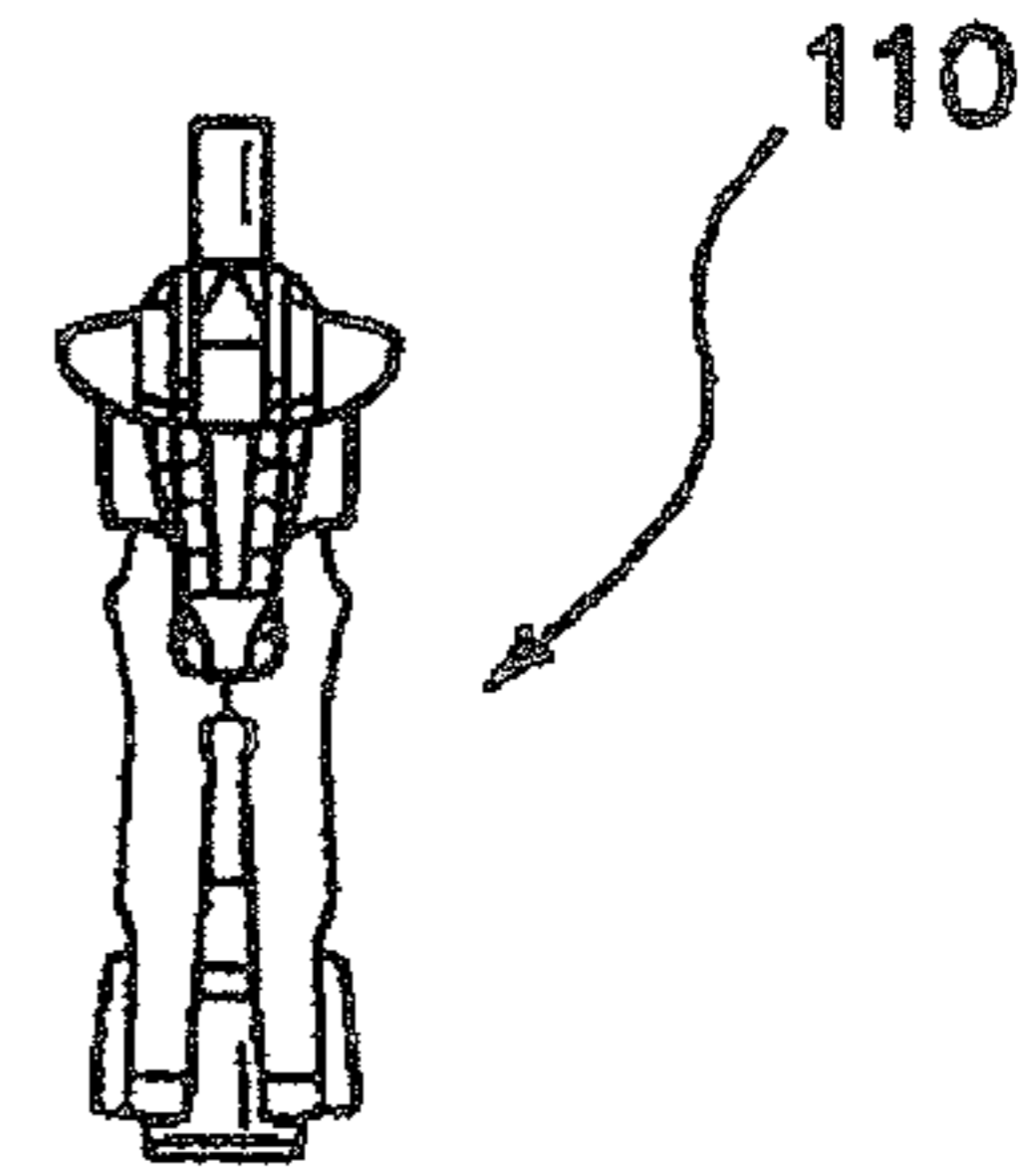

FIG. 22

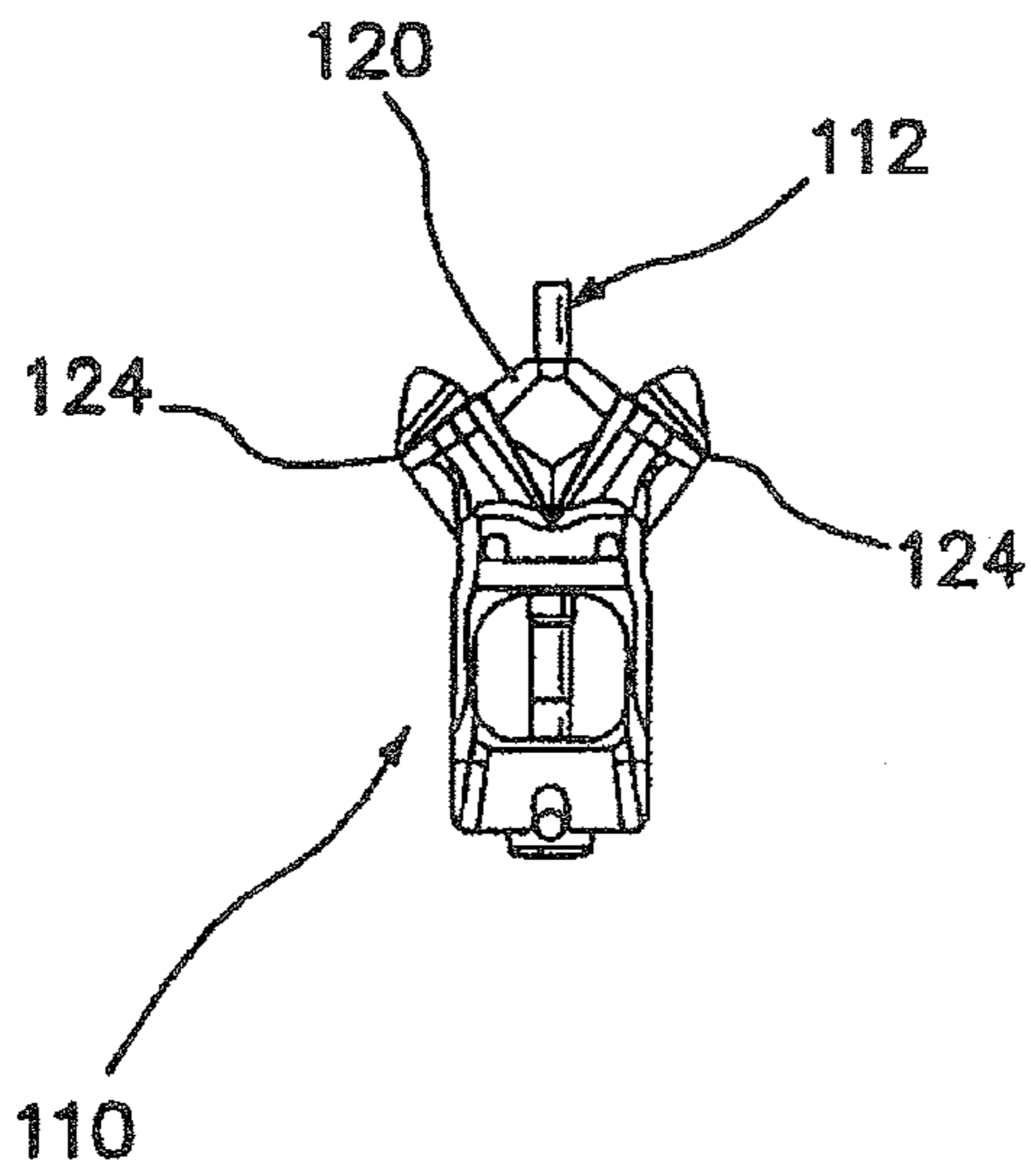
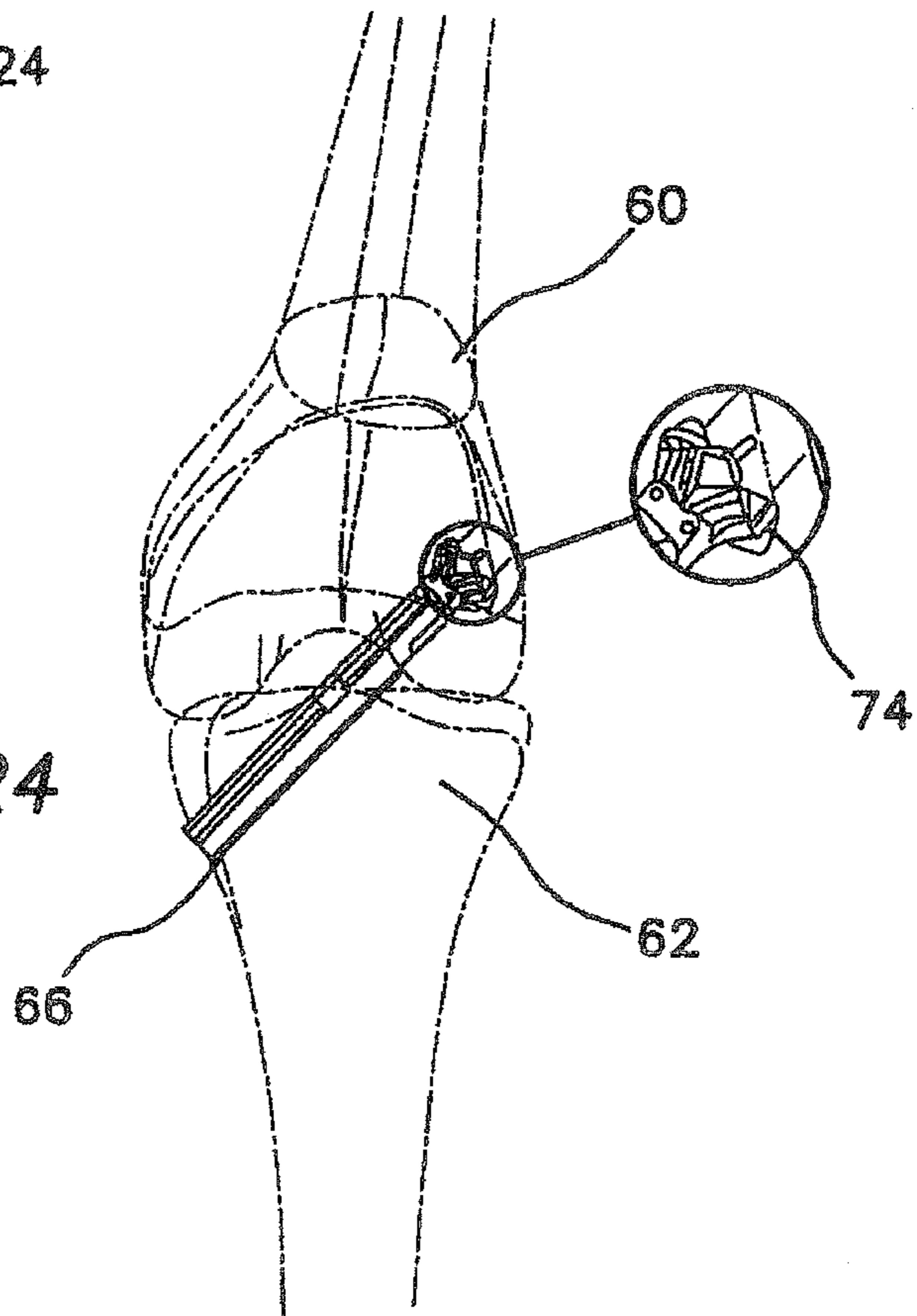
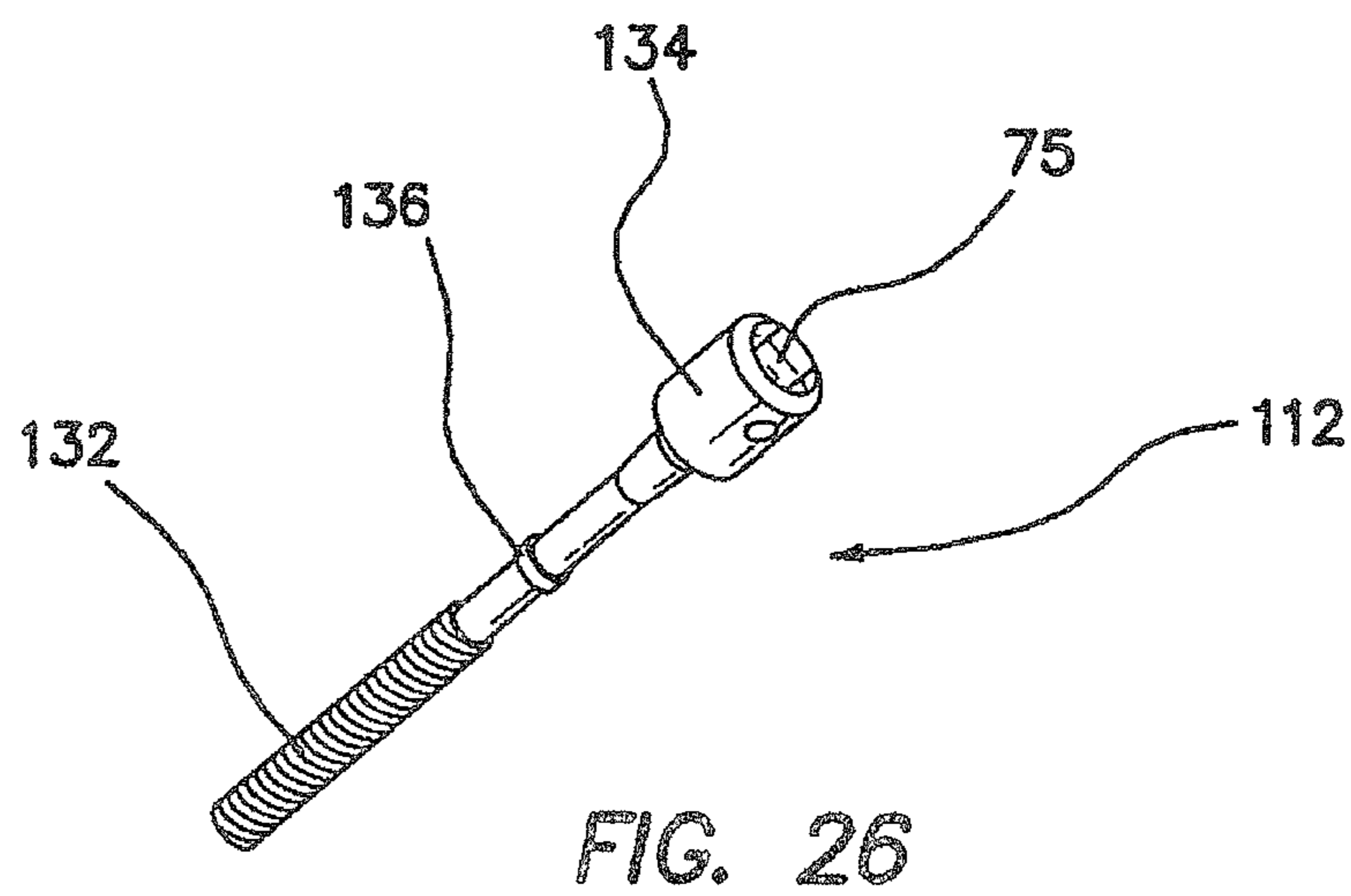
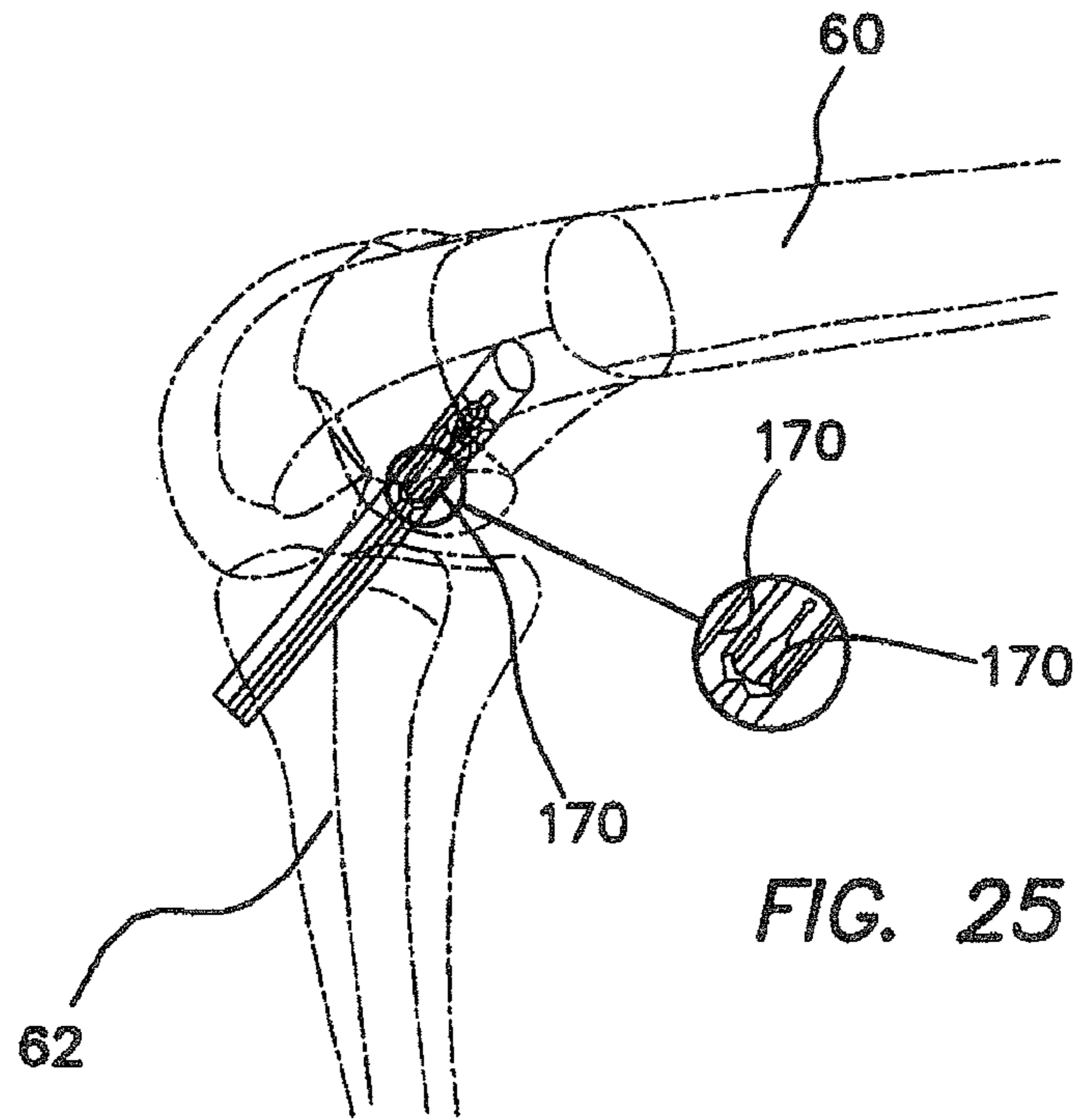
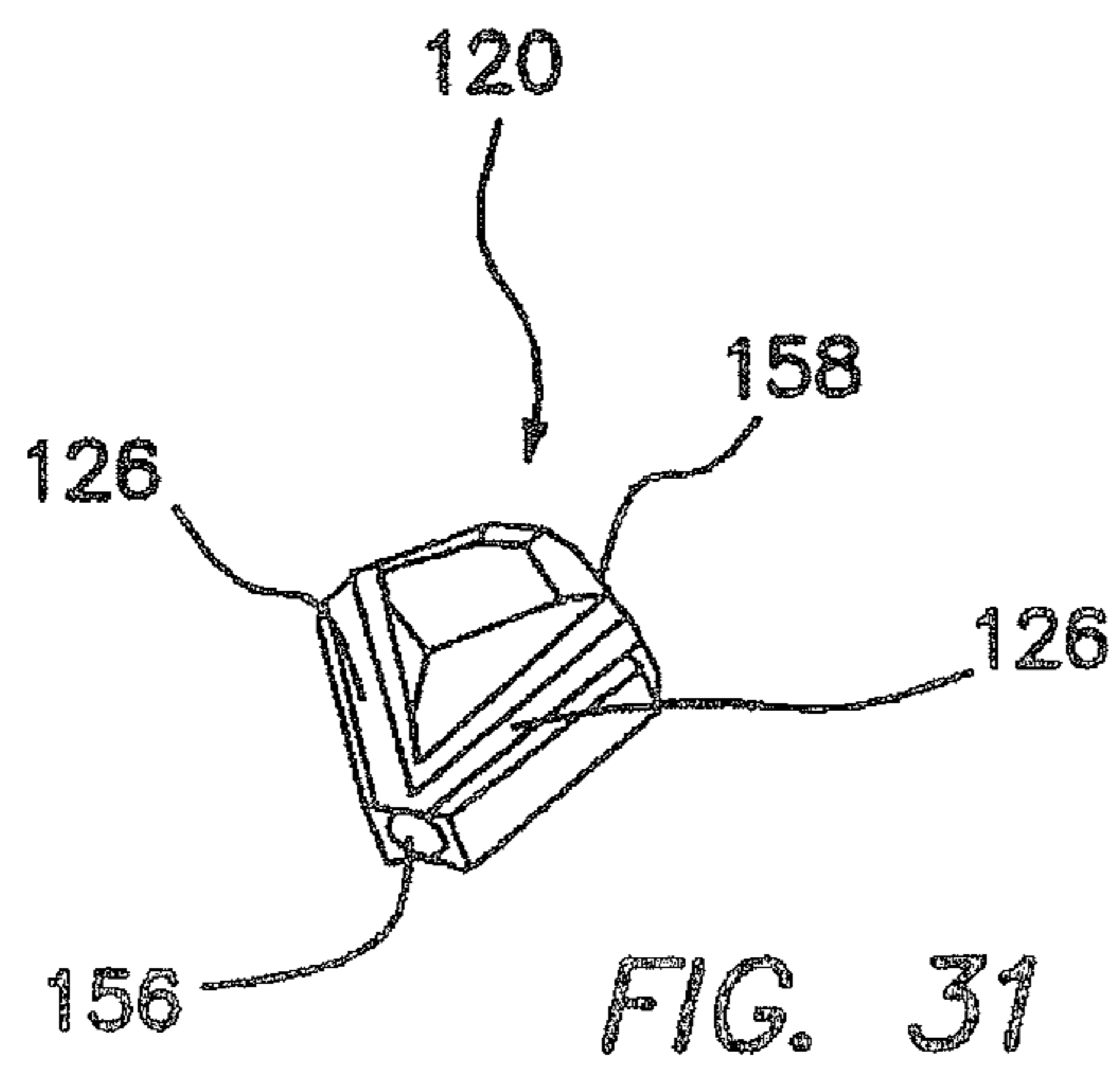
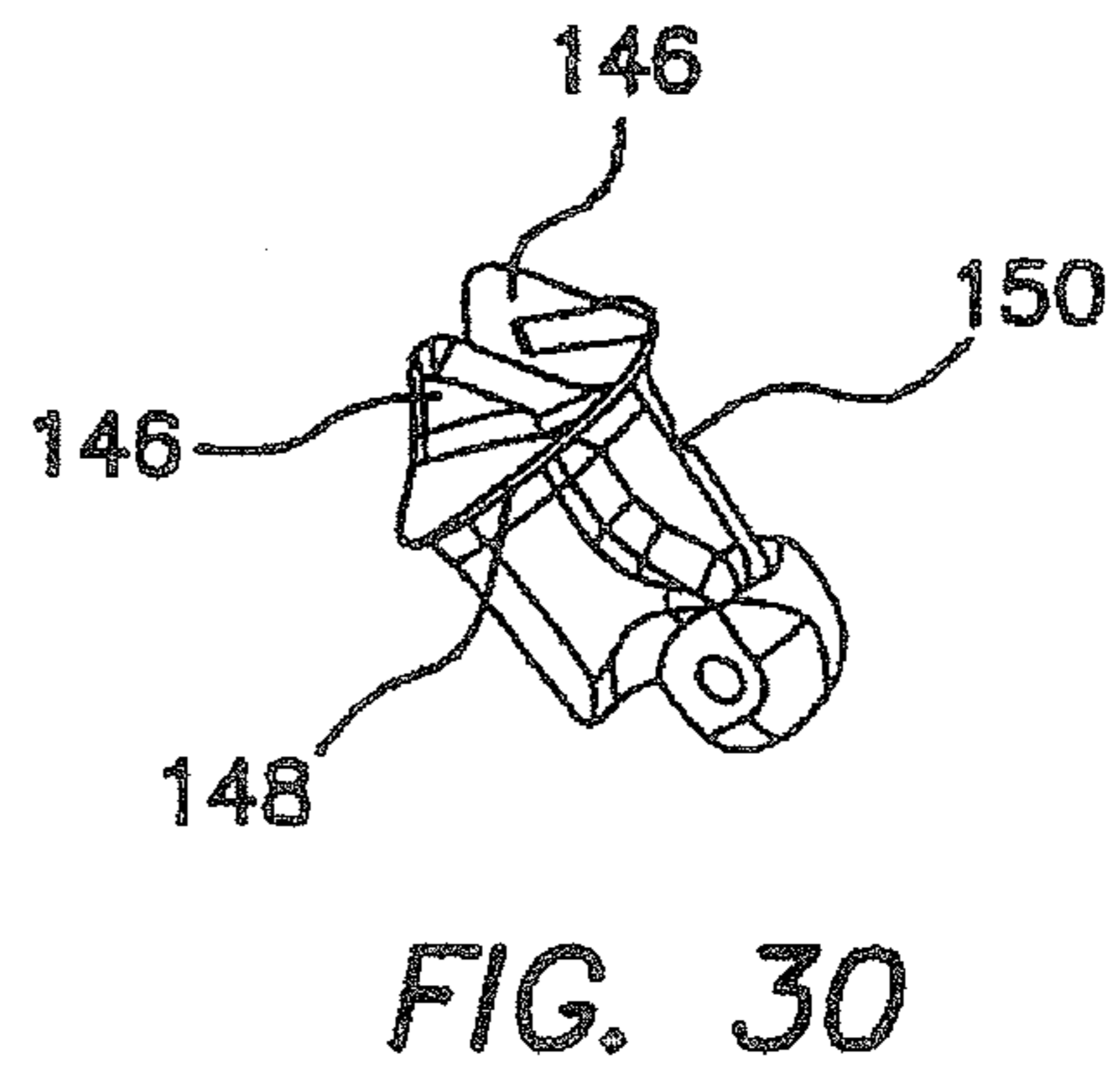
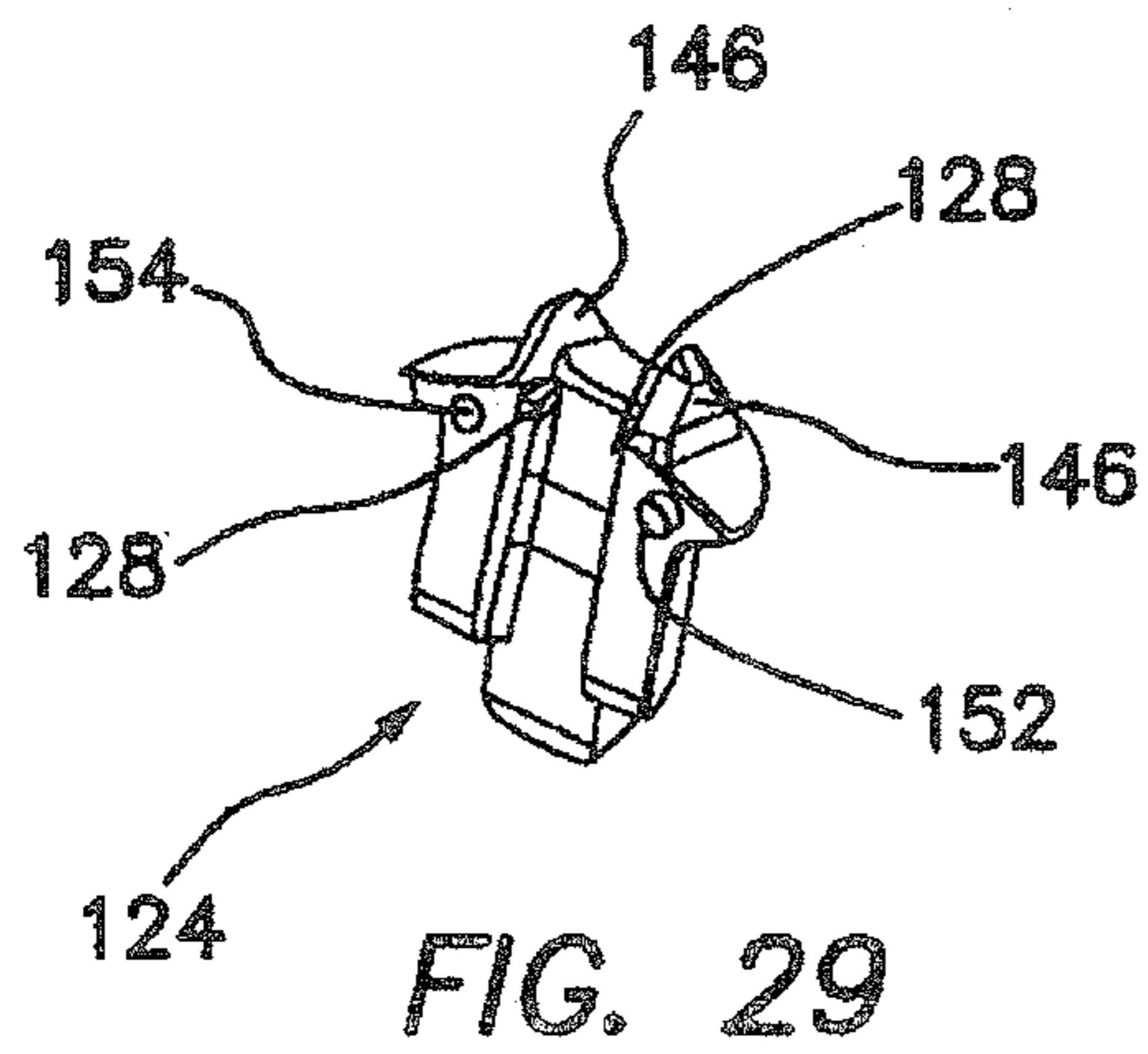
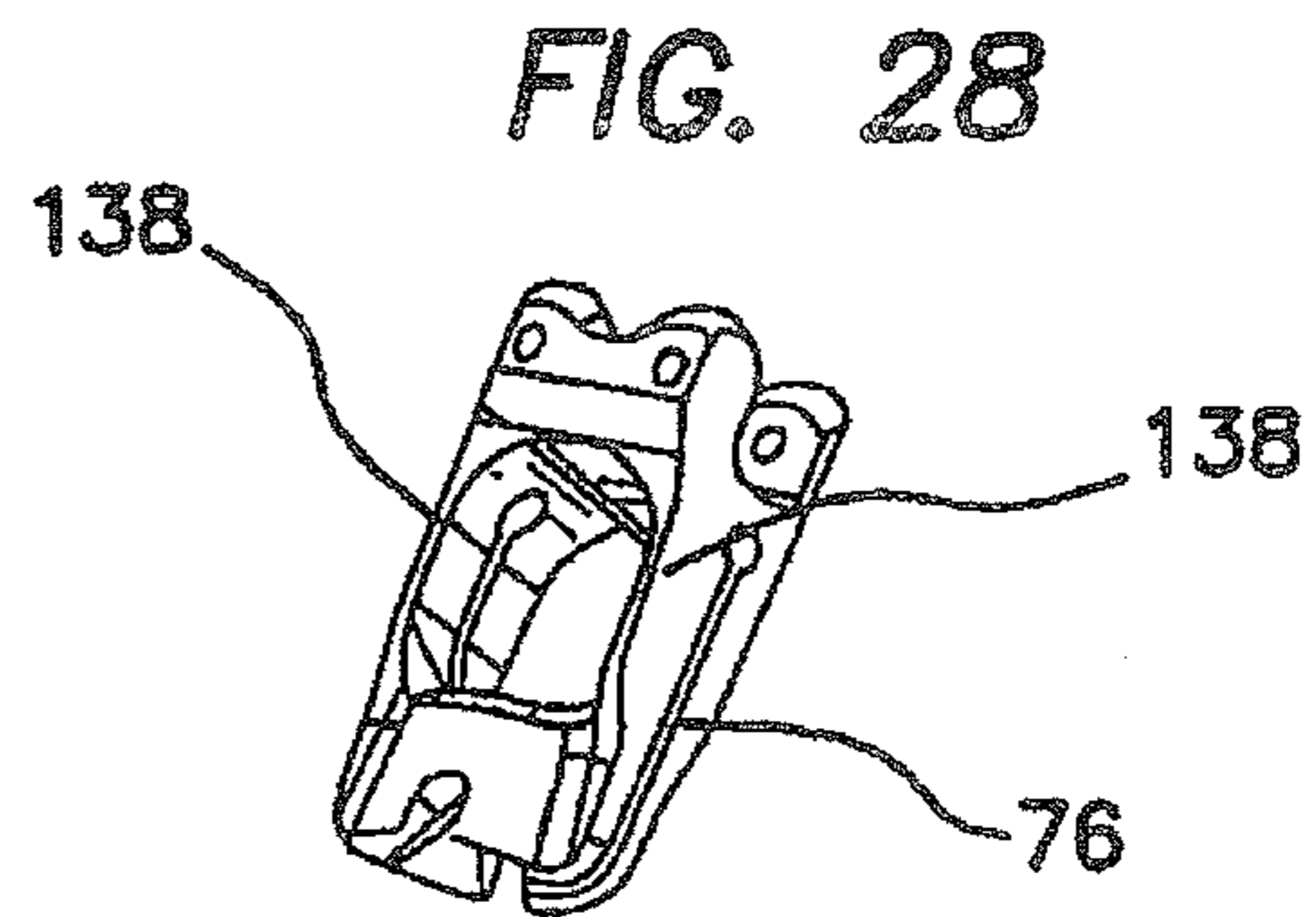
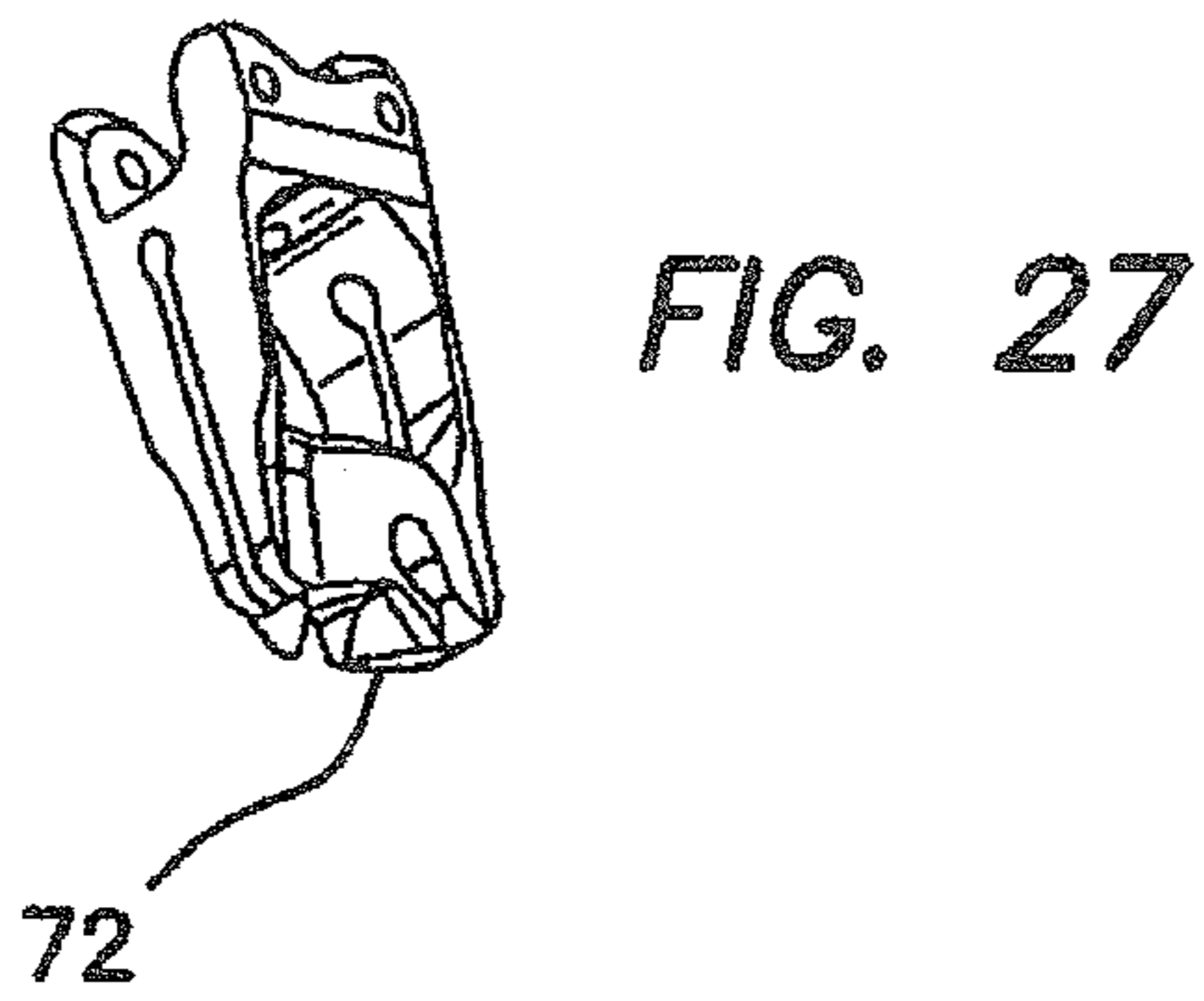

FIG. 24







		Pull out Forces (N)
Cancellous Implant	Mean	1164.2
	Standard Deviation	215.9
	Minimum Value	728
	Maximum Value	1643
		Pull out Forces (N)
RCI Screws	Mean	532.7
	Standard Deviation	349.7
	Minimum Value	135.7
	Maximum Value	1230.9

FIG. 32

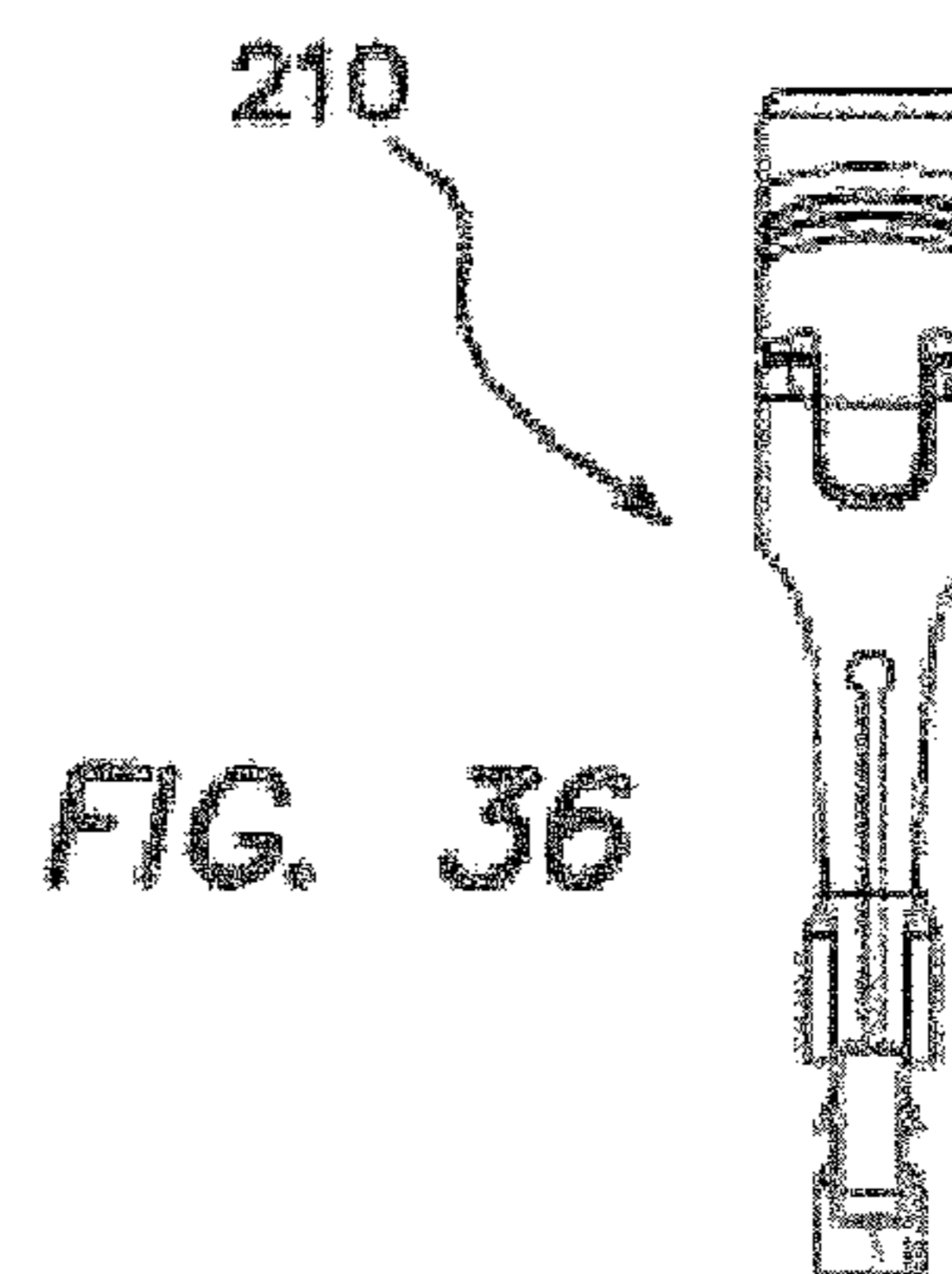
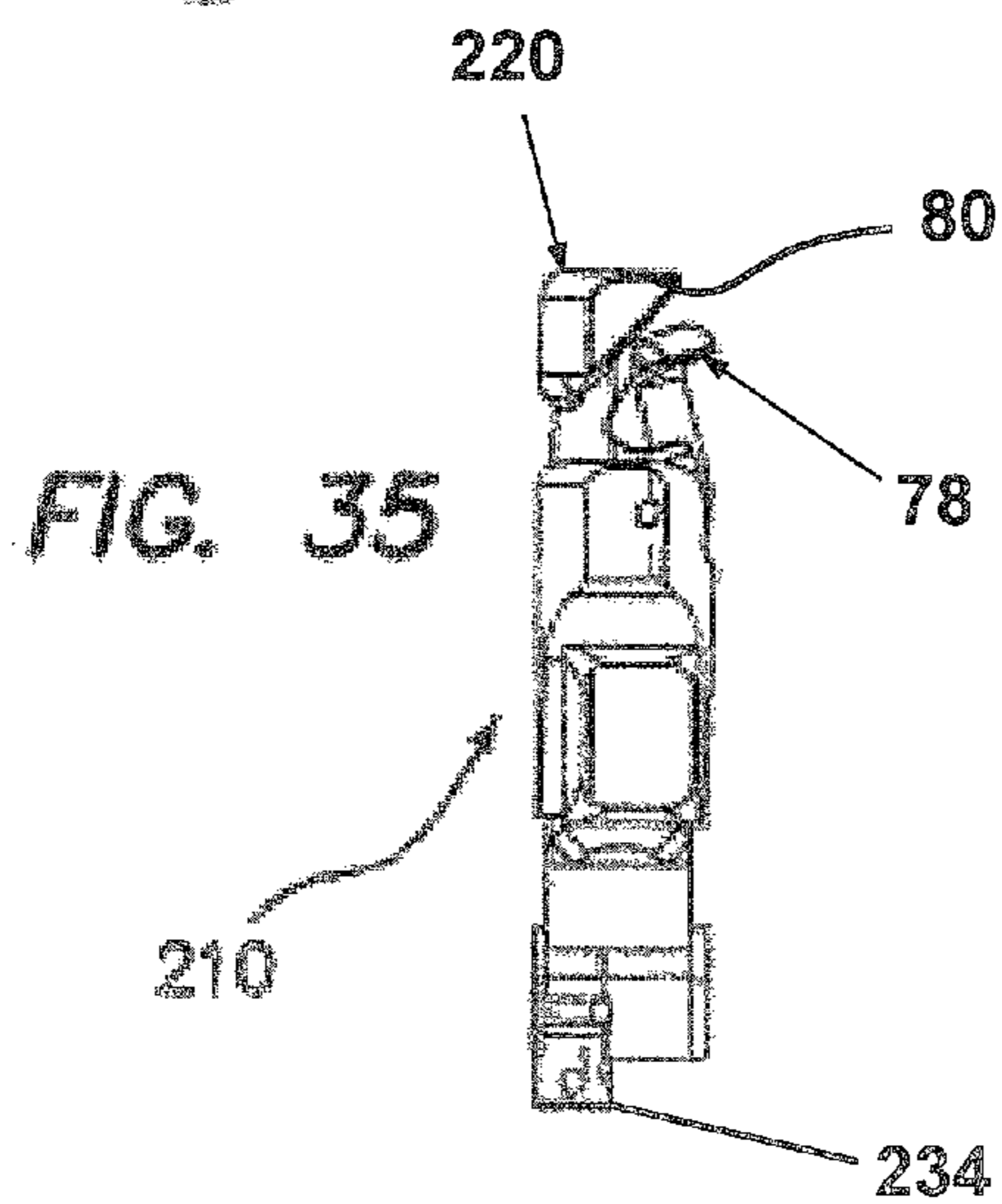
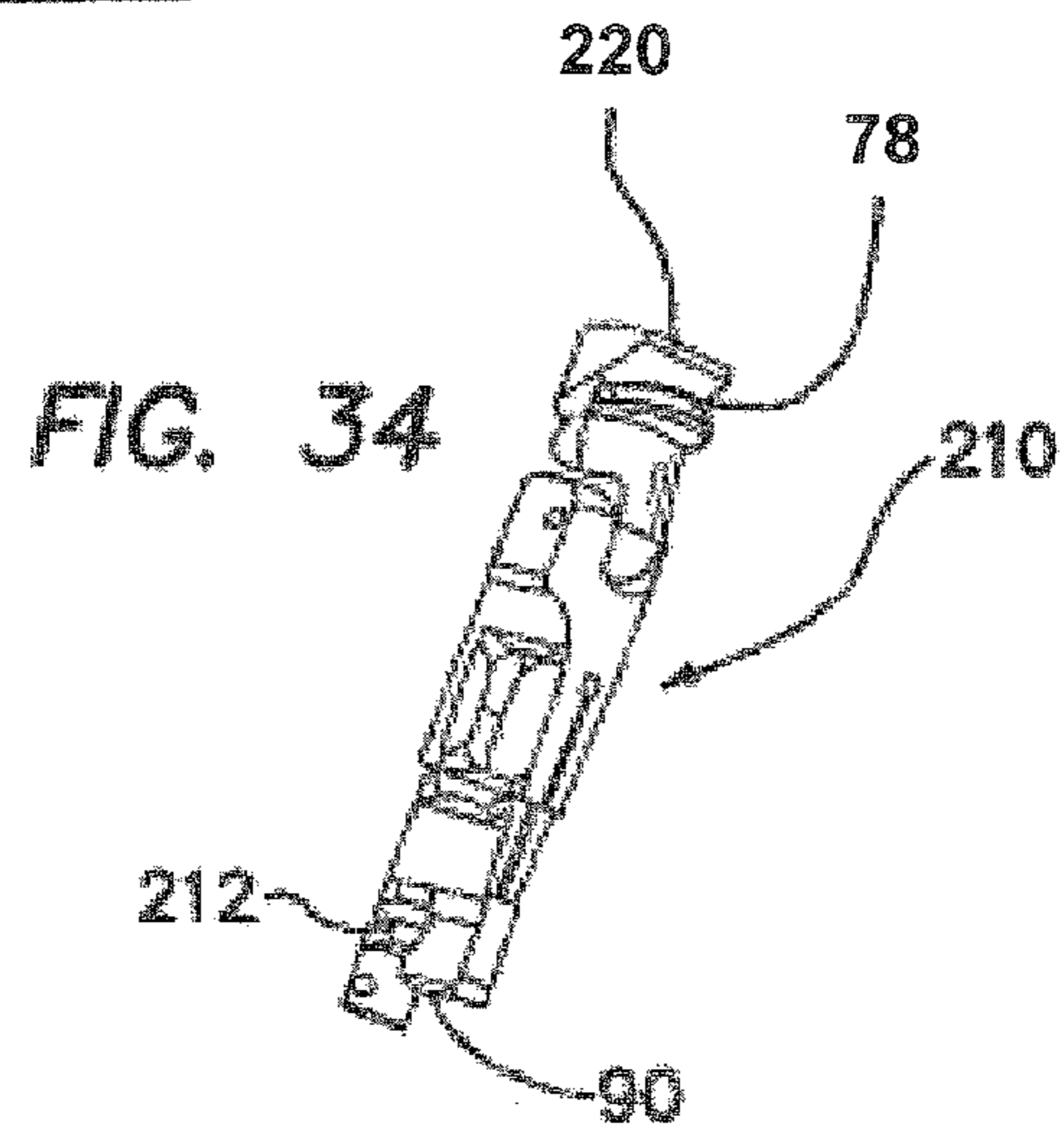
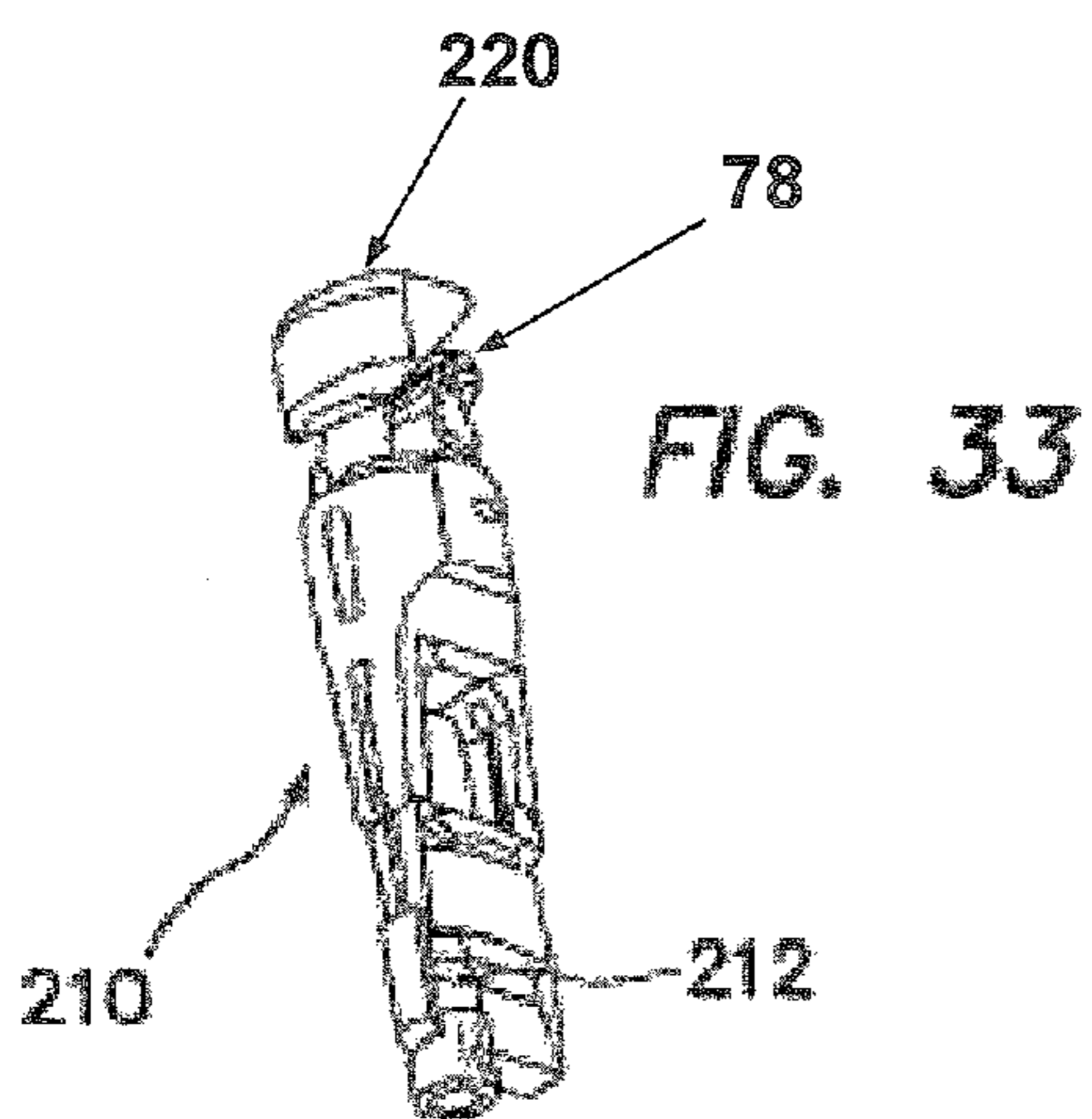

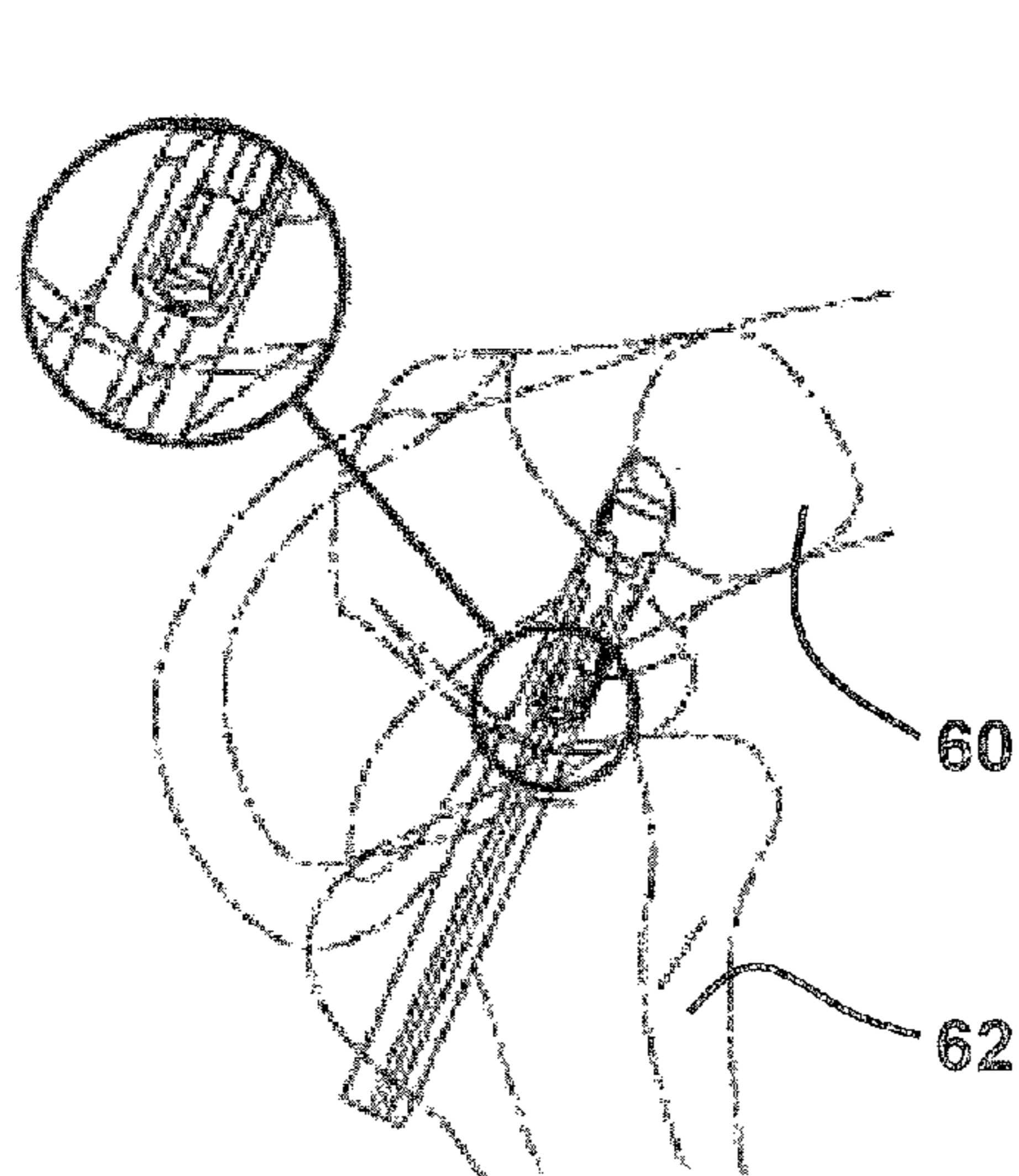
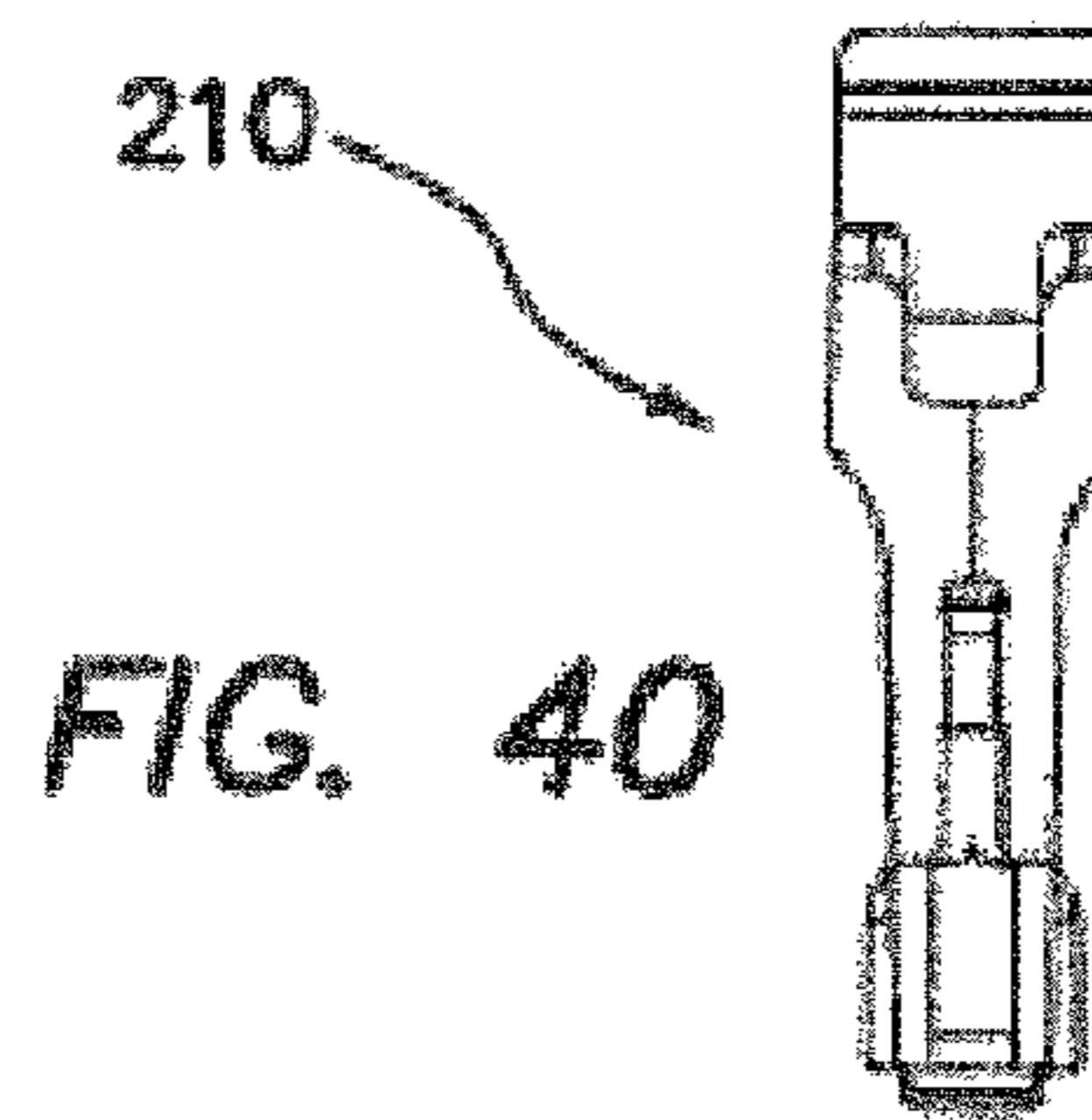
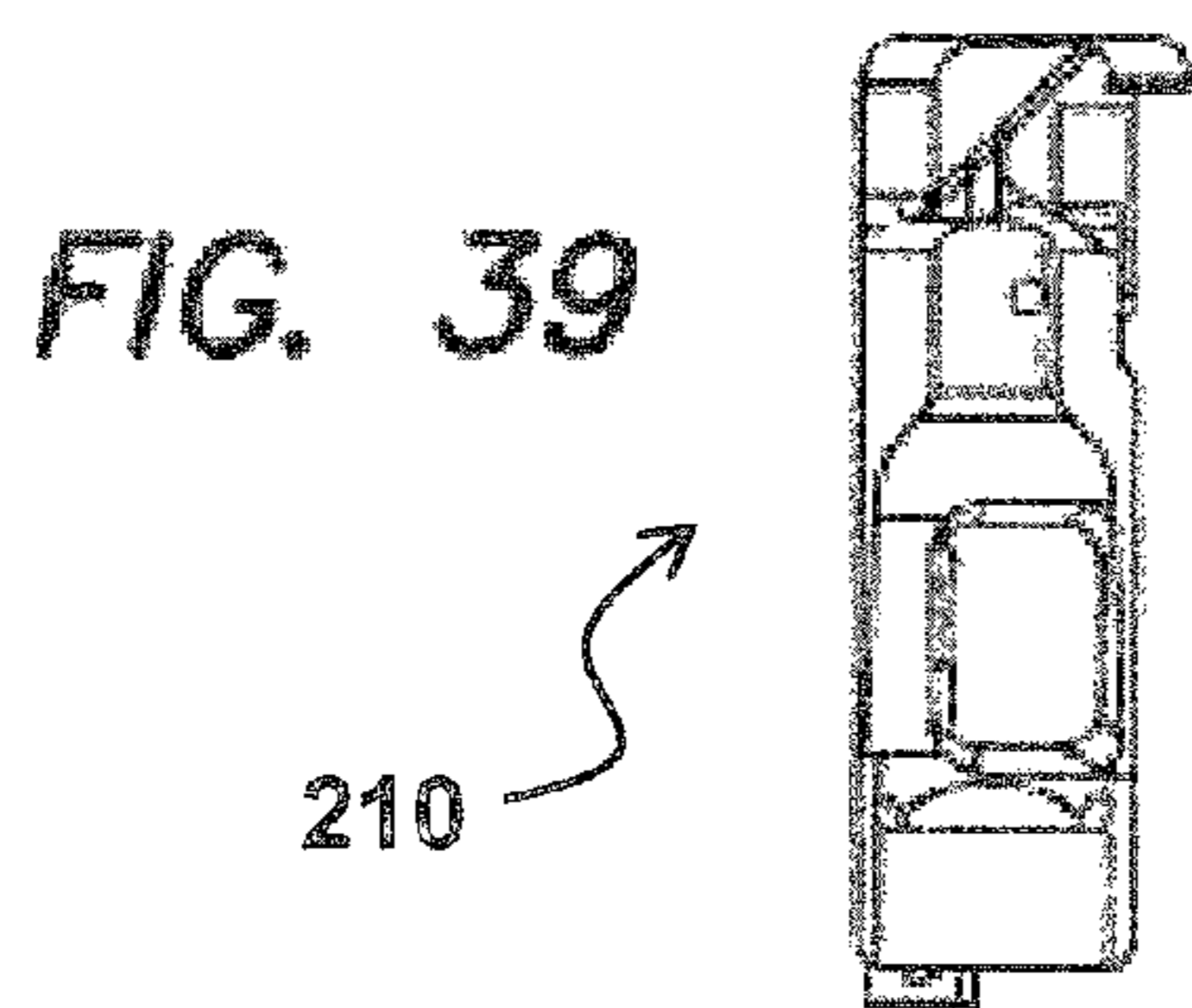
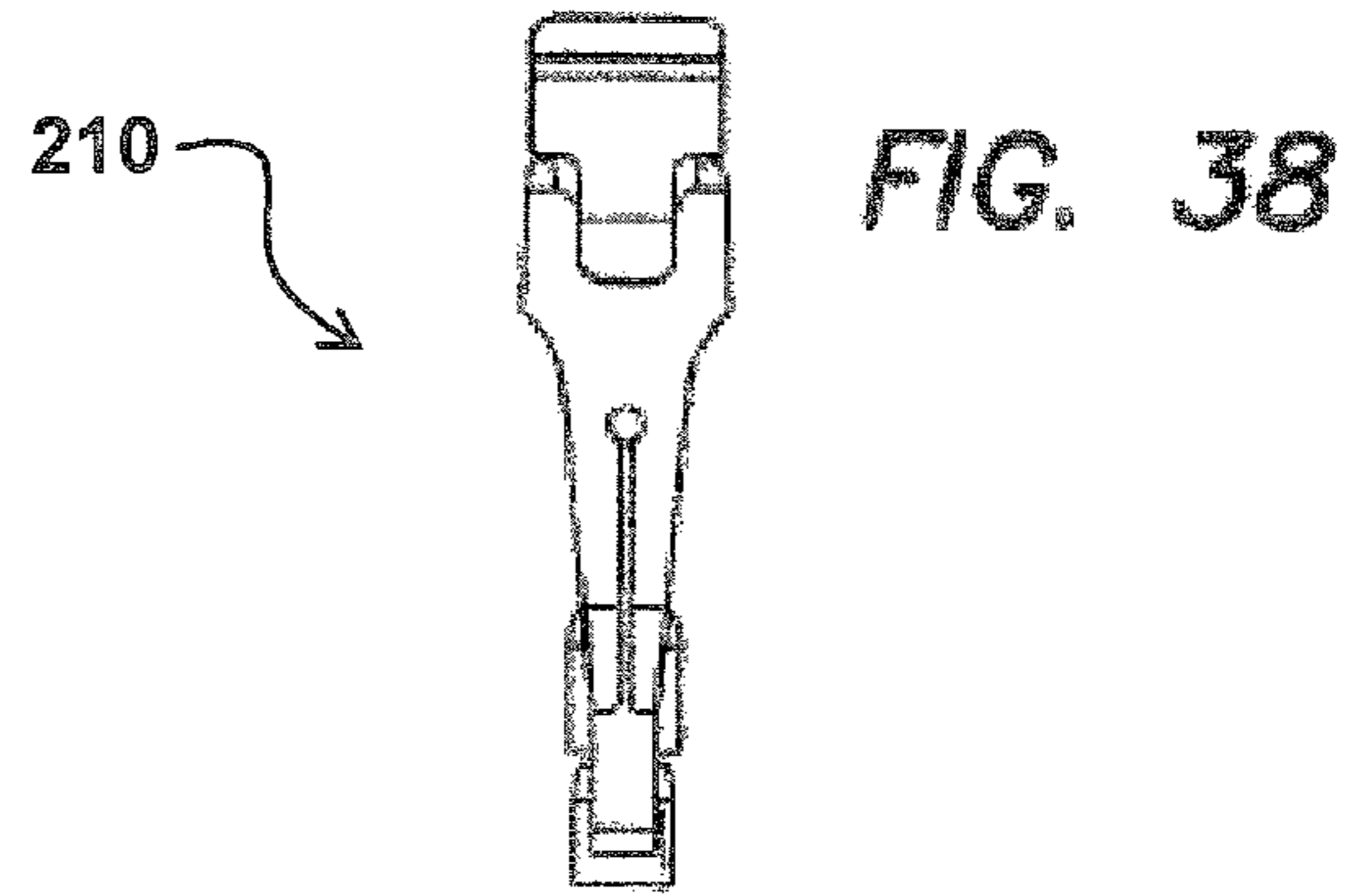
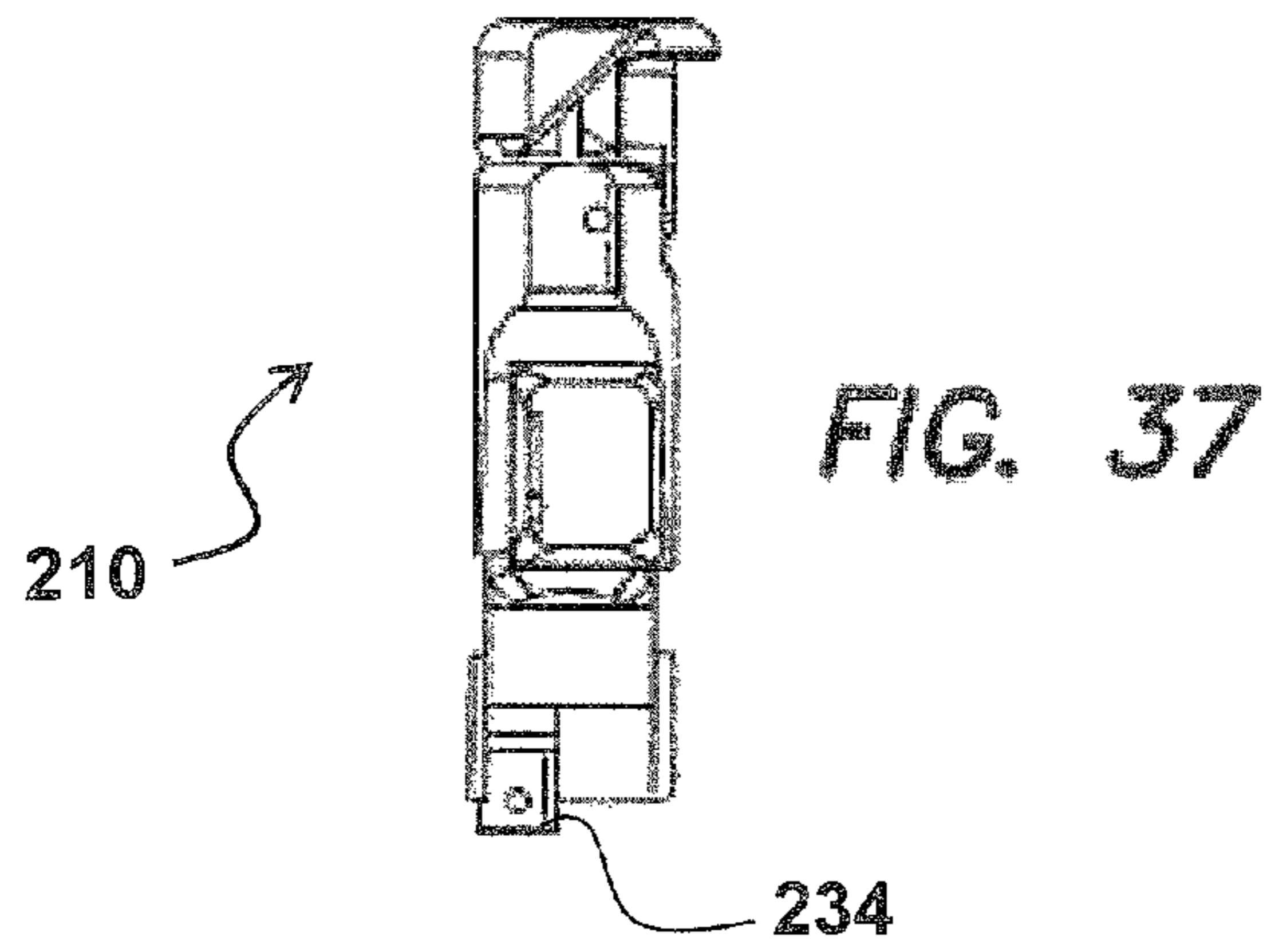

FIG. 41

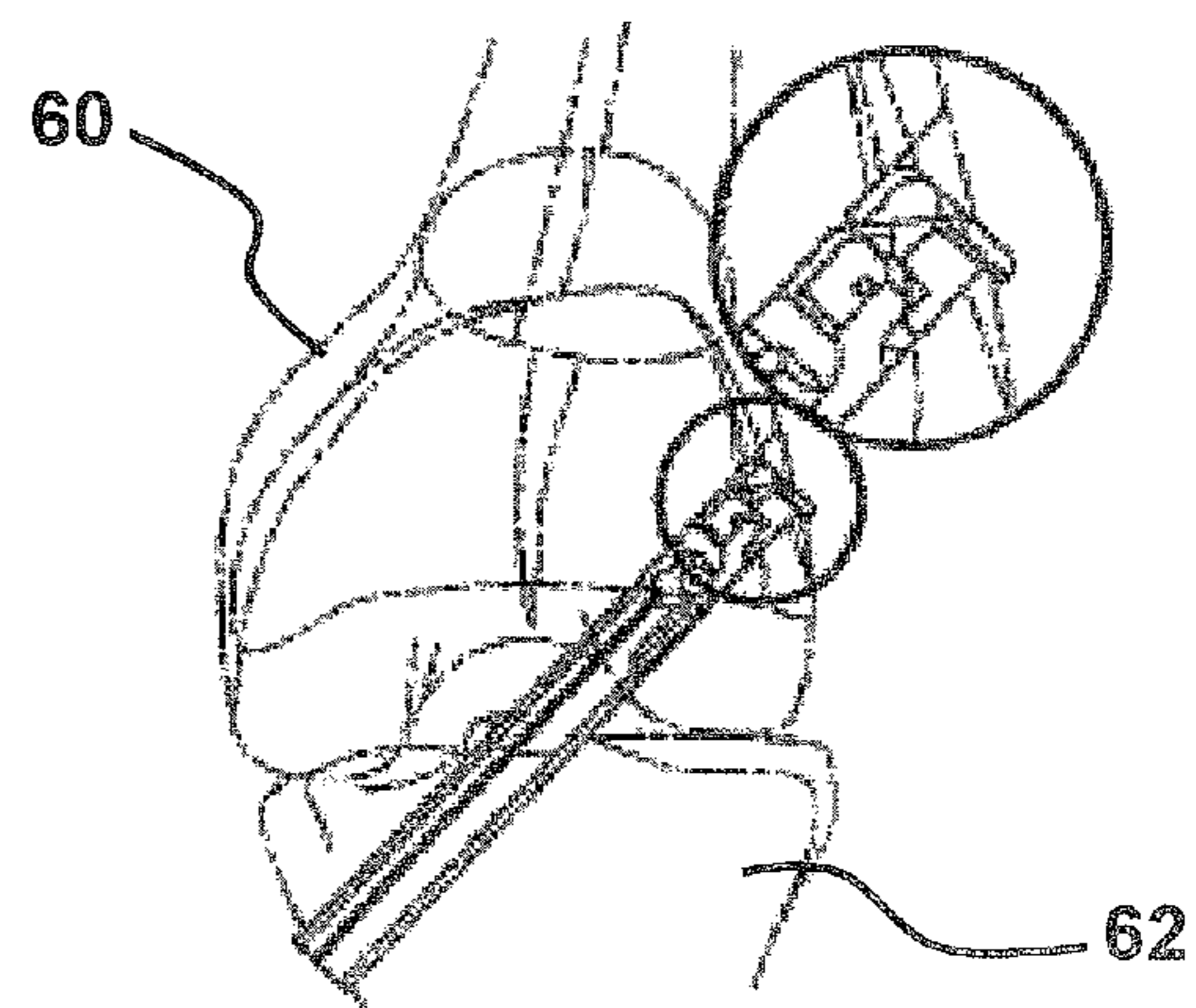

FIG. 42

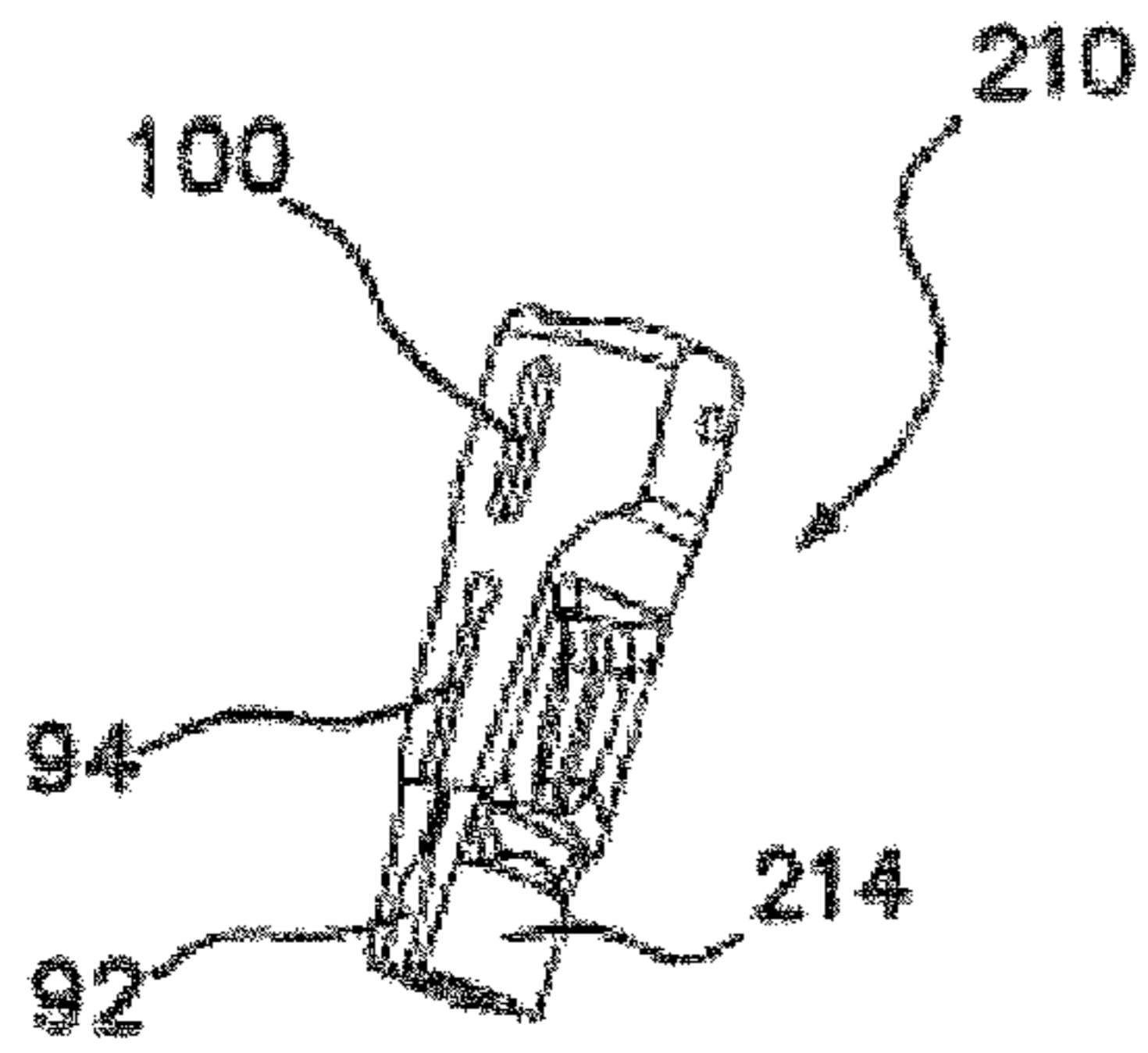

FIG. 43

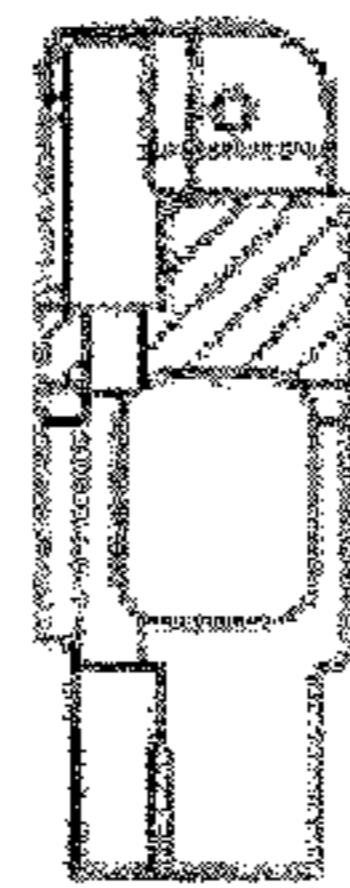

FIG. 44

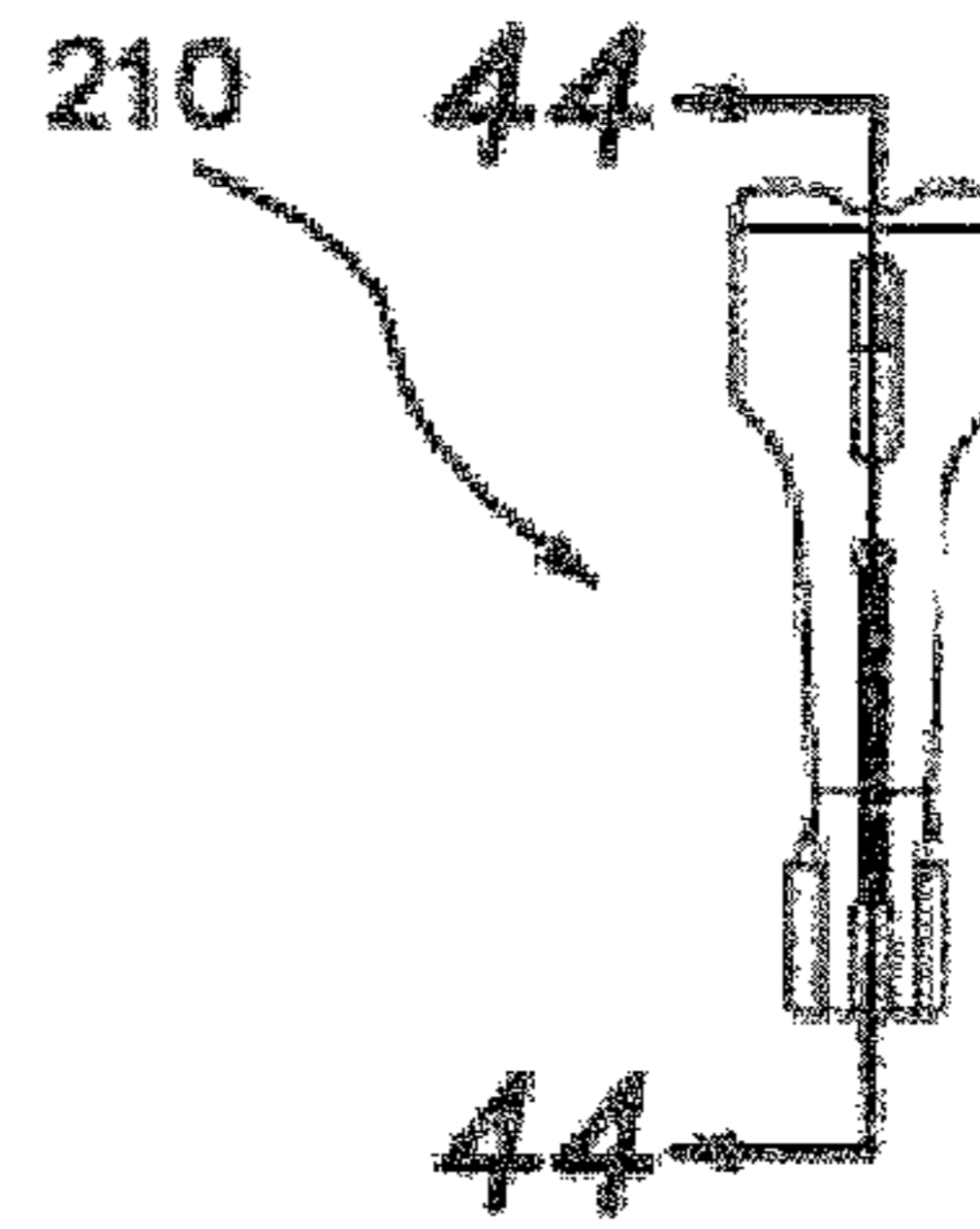

FIG. 45

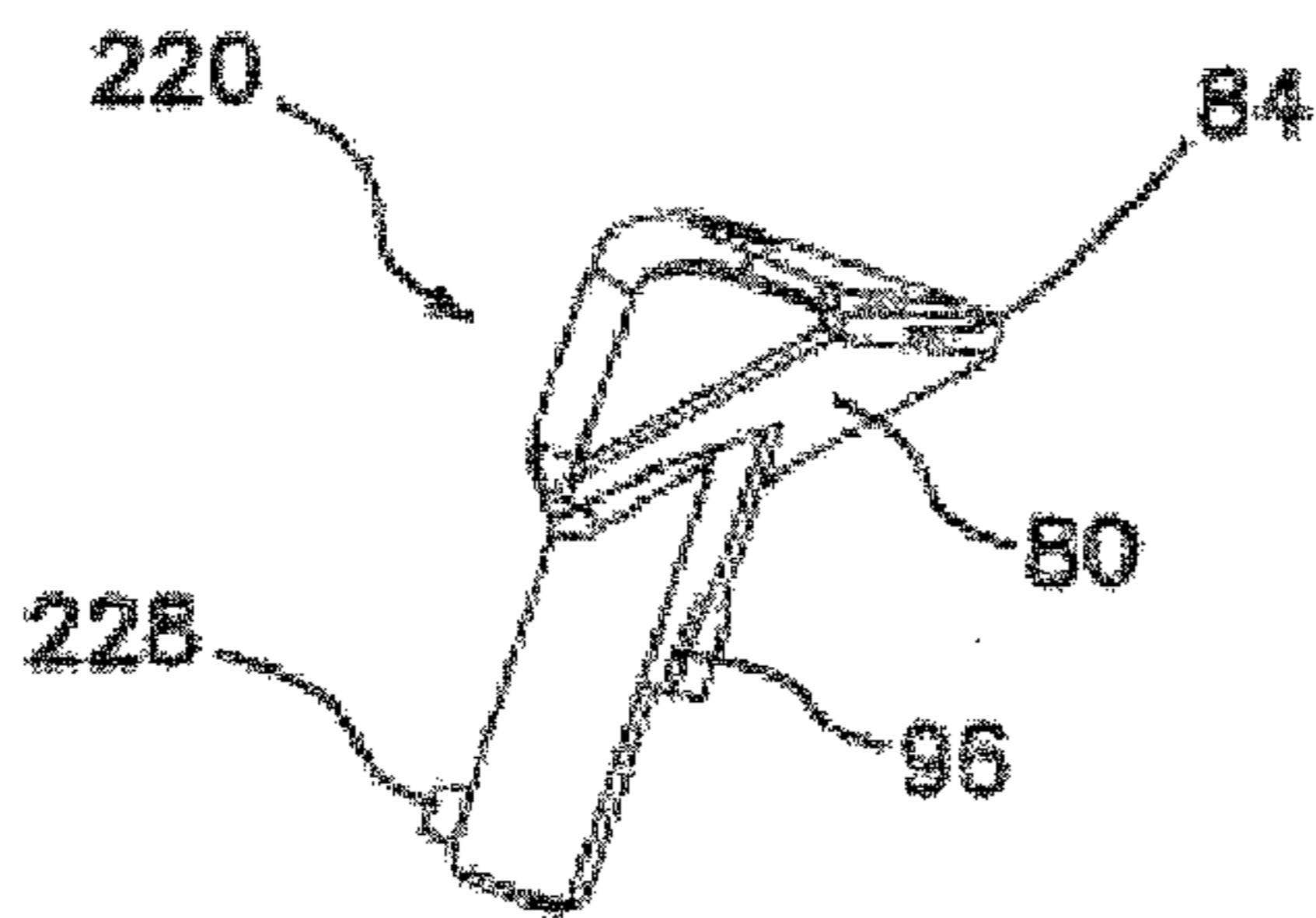

FIG. 46

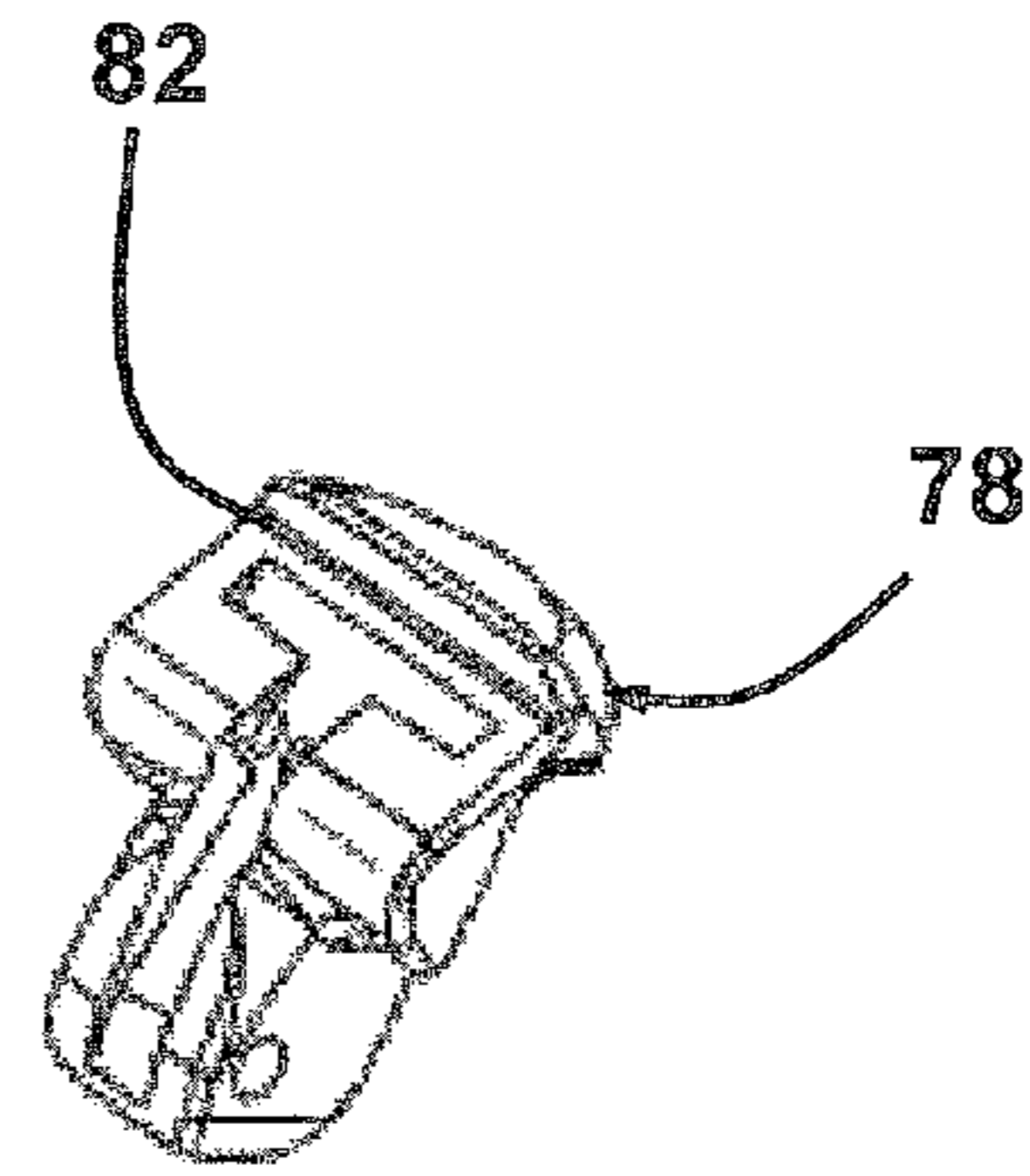

FIG. 47

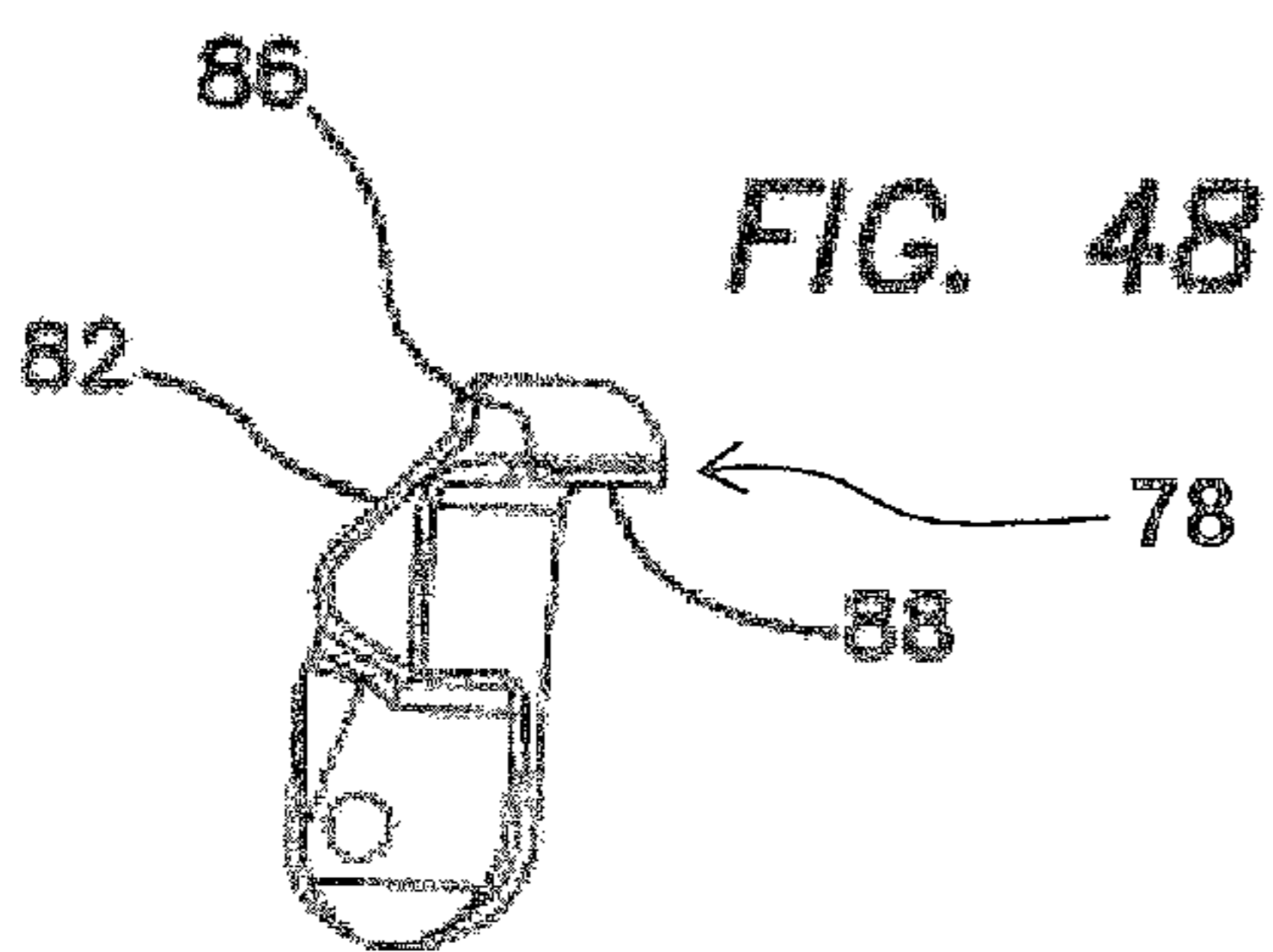

FIG. 48

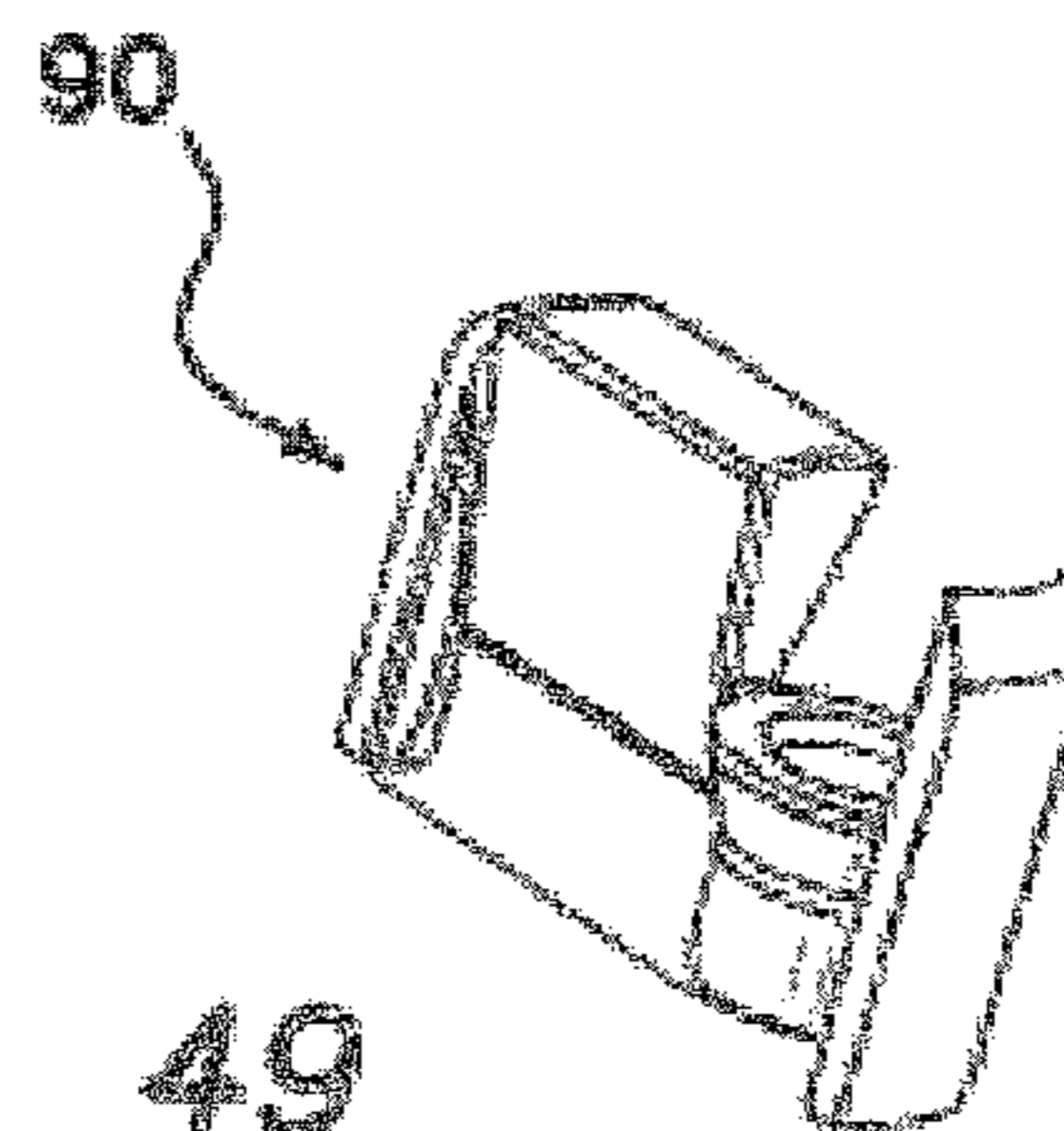
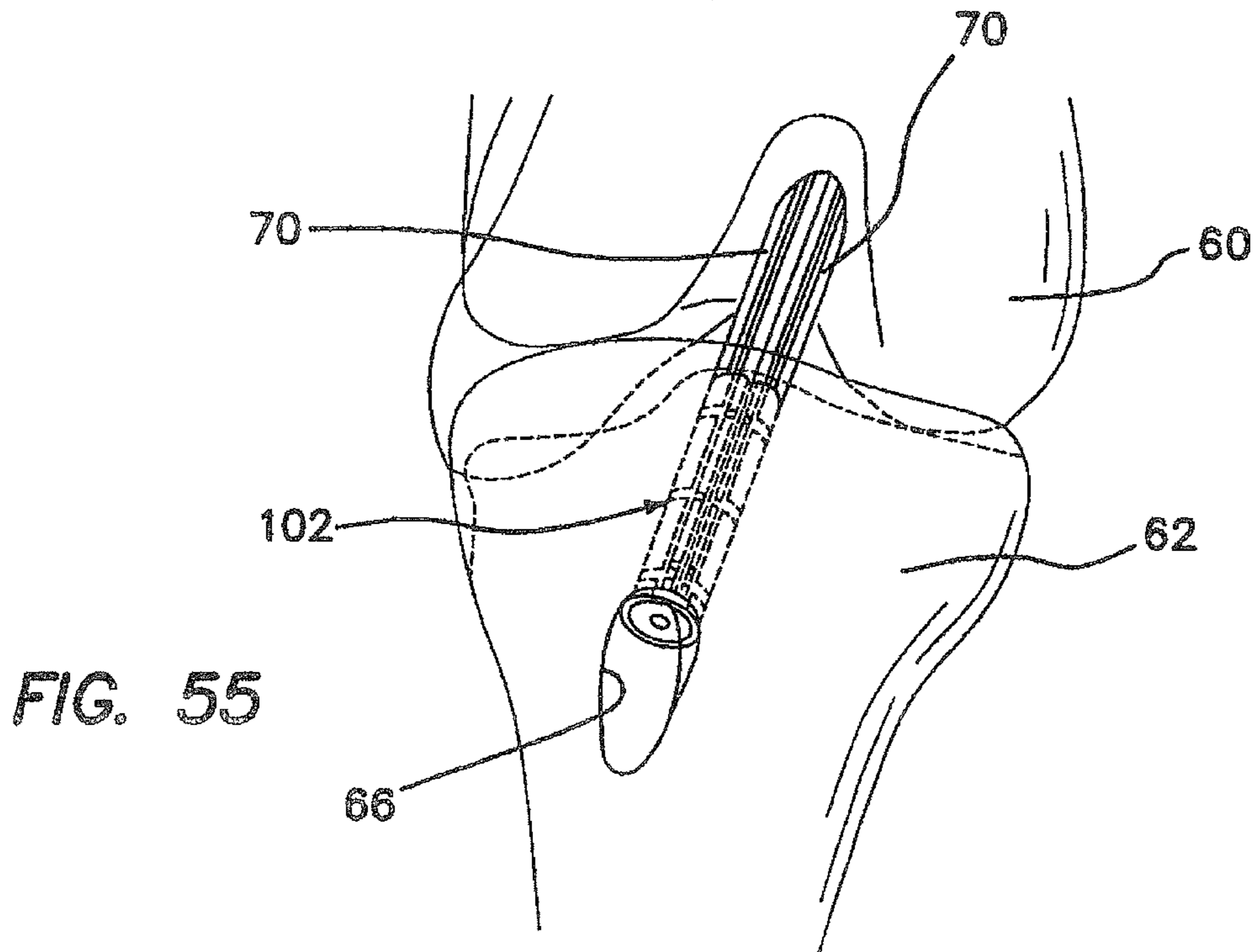
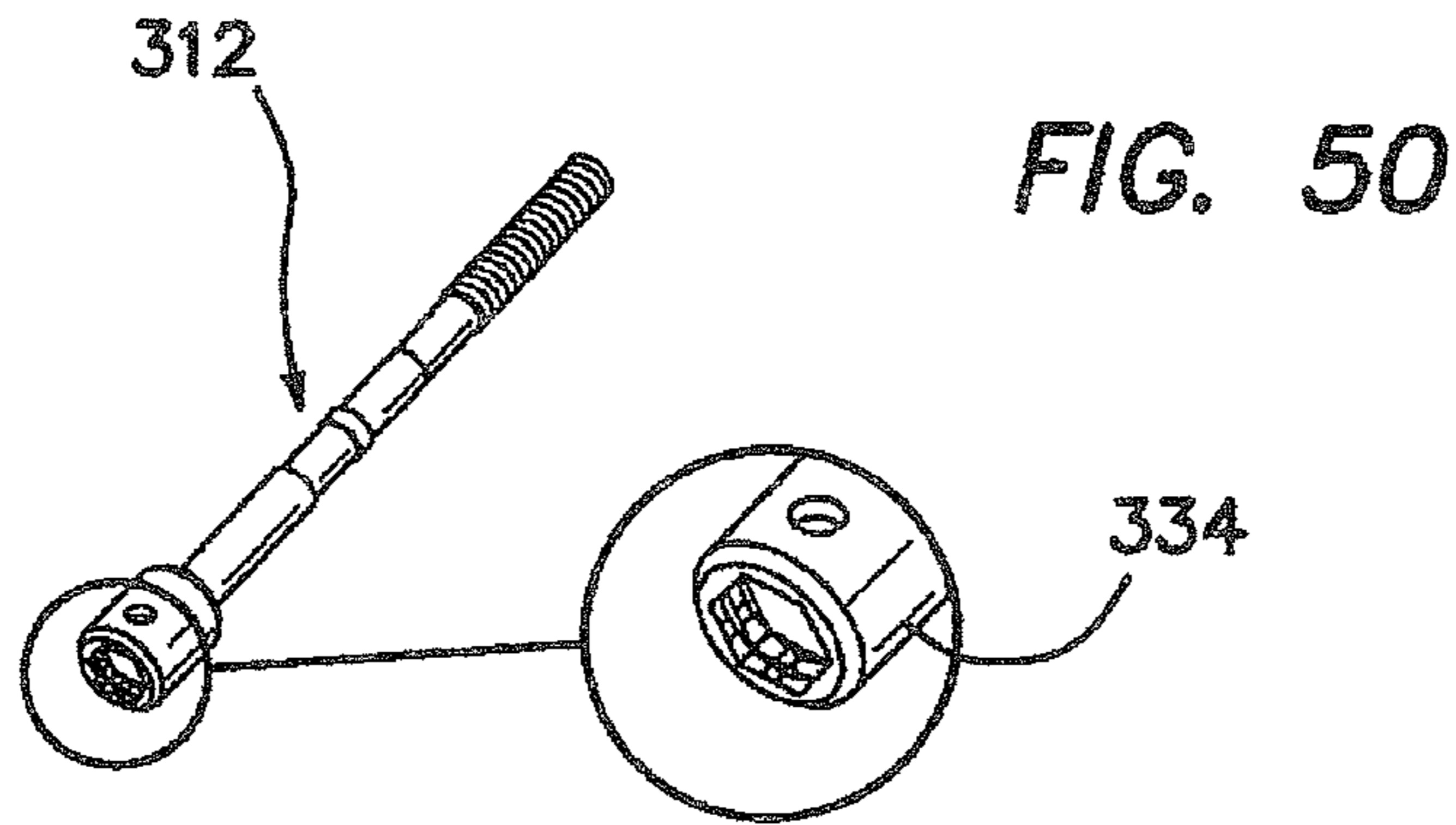

FIG. 49



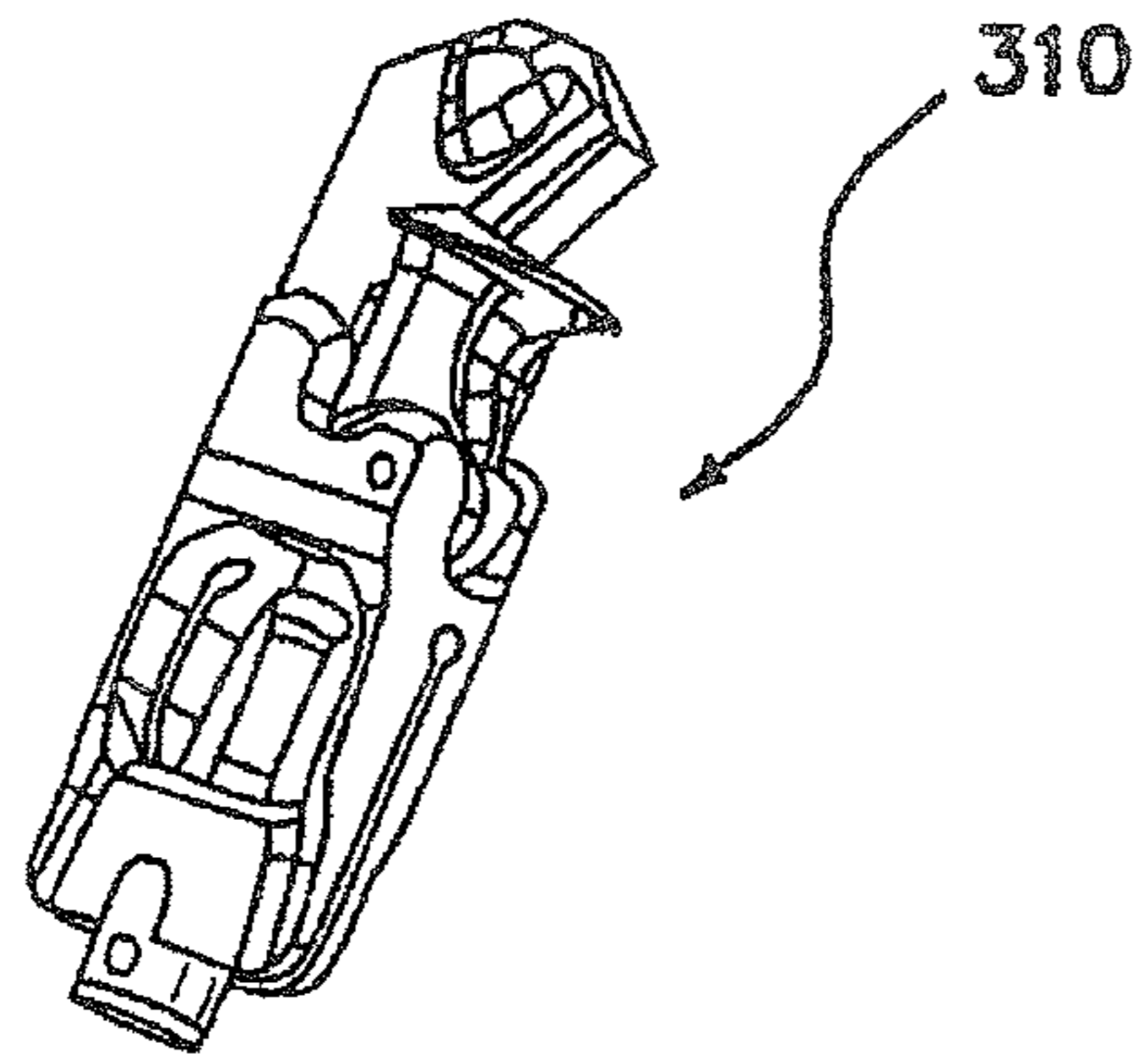

FIG. 51

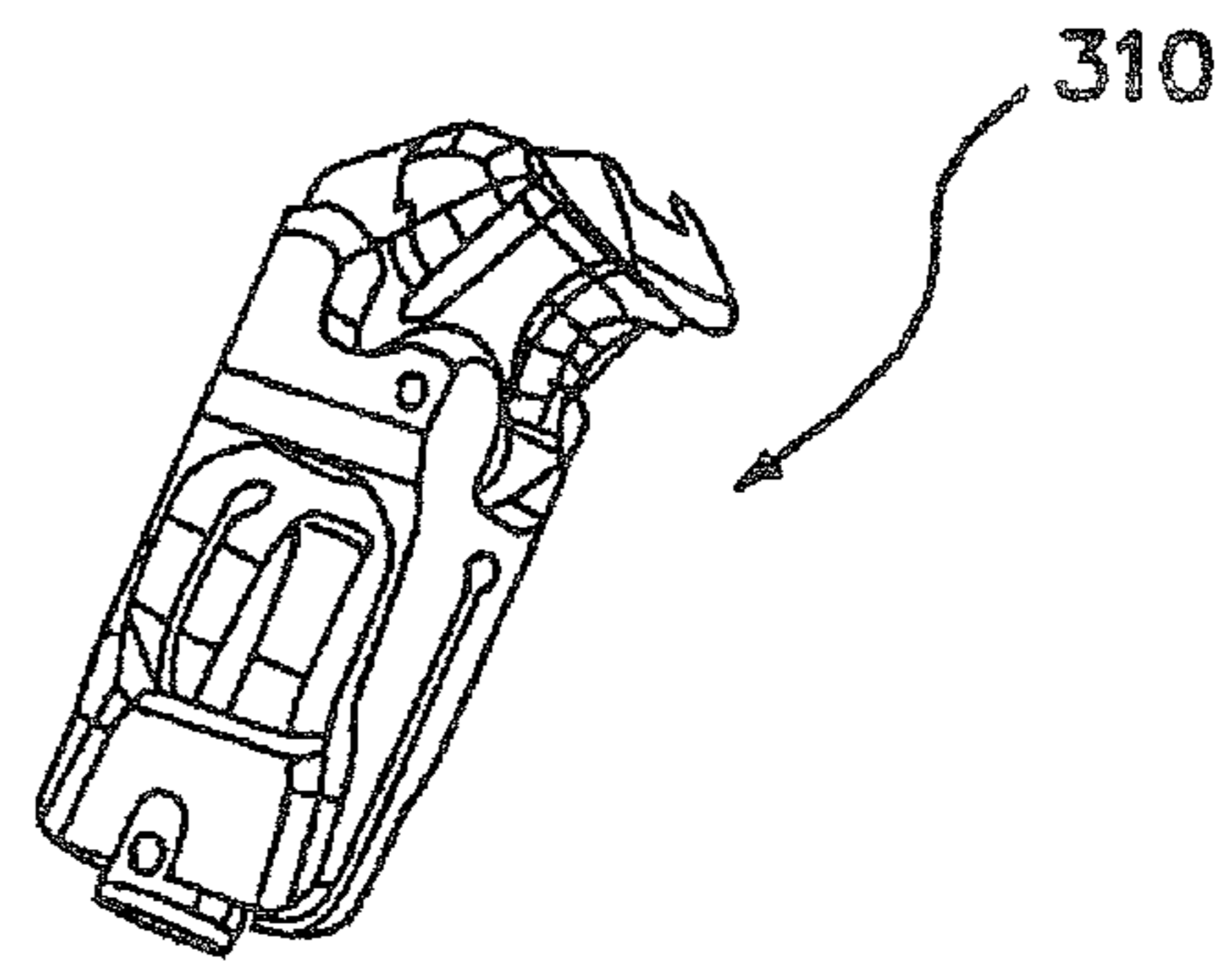

FIG. 52

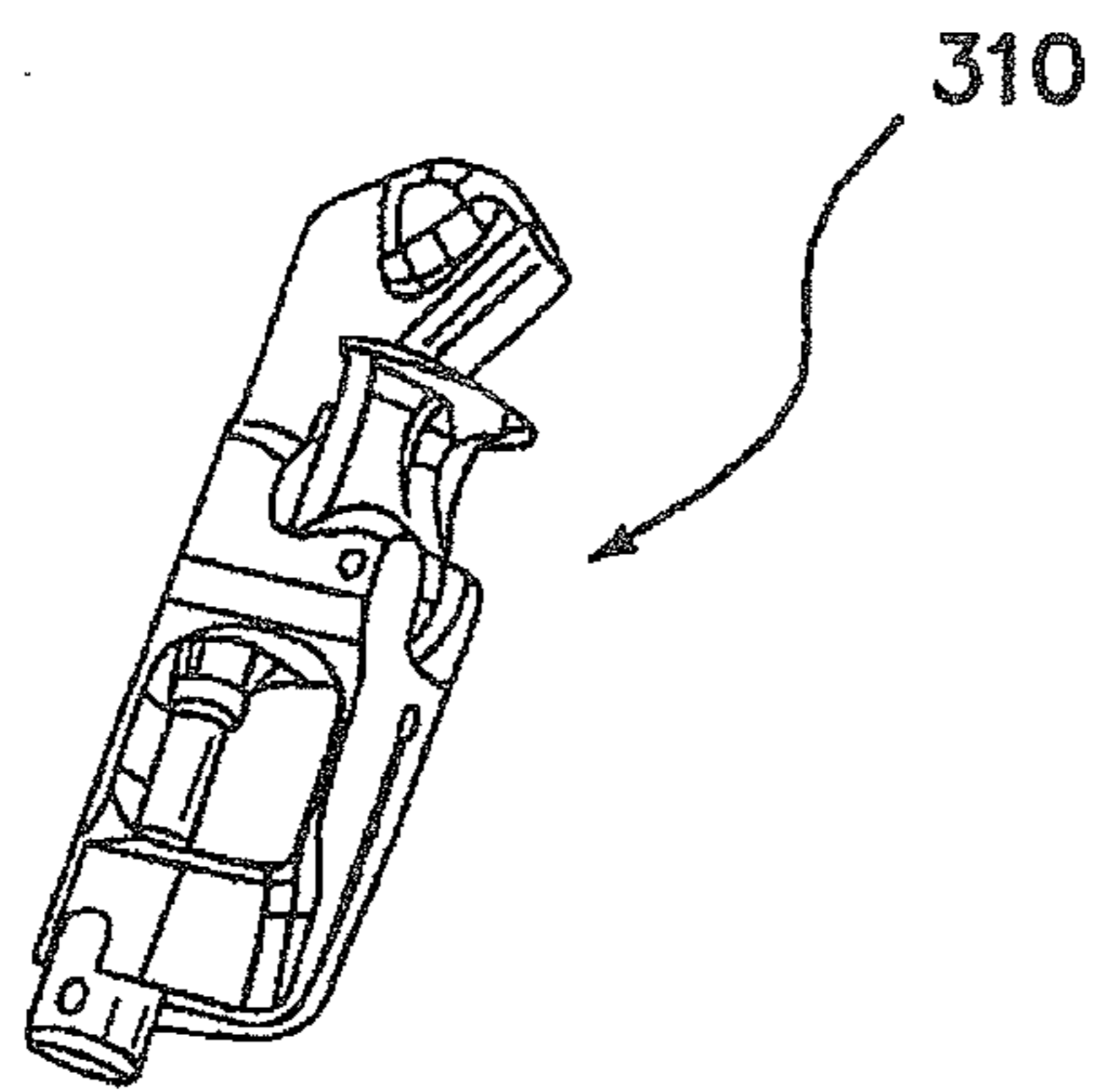

FIG. 53

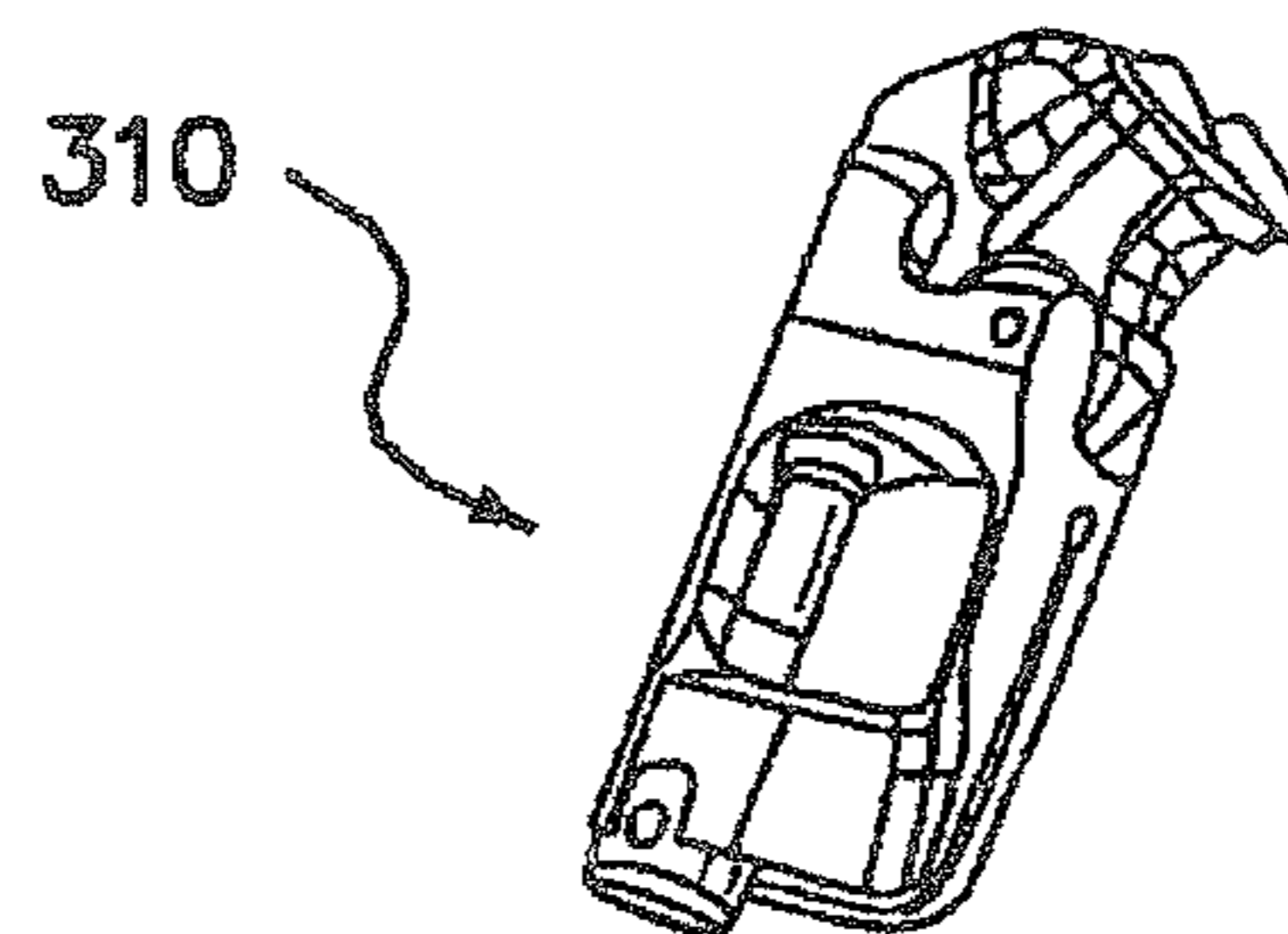

FIG. 54

METHODS AND SYSTEMS FOR MATERIAL FIXATION

This application is a continuation application under 35 U.S.C. 120 of commonly assigned U.S. patent application Ser. No. 11/923,526, entitled Methods and Systems for Material Fixation, filed Oct. 24, 2007, now allowed, which in turn claims the benefit under 35 U.S.C. 119(e) of the filing date of Provisional U.S. Application Ser. No. 60/854,178, entitled Methods and Systems for Material Fixation, filed on Oct. 24, 2006. Each of the above referenced applications are which application is expressly incorporated herein by reference, in their entirety.

This application is also related to co-pending U.S. application Ser. No. 11/281,566 entitled Devices, Systems, and Methods for Material Fixation, filed on Nov. 18, 2005 and published as U.S. Patent Application Publication No. US 2006/0155287 on Jul. 13, 2006, and to co-pending U.S. application Ser. No. 11/725,981, entitled Devices, Systems, and Methods for Material Fixation, filed on Mar. 20, 2007. Both of these prior pending applications are commonly owned and herein expressly incorporated by reference.

BACKGROUND OF THE INVENTION

The present invention relates generally to devices, systems and methods for material fixation. More specifically, the present invention relates to a technique that can be used to firmly hold a soft tissue or graft against bone tissue within a bone tunnel.

One of the most common needs in orthopedic surgery is the fixation of tendon to bone. The fixation of diseased tendons into a modified position is called tenodesis and is commonly required in patients with injury to the long head of the biceps tendon in the shoulder. In addition, tendons which are torn from their insertion site into bone also frequently require repair. This includes distal biceps tendon tears, rotator cuff tears, and torn flexor tendons in the hand. Tendons are also frequently used in the reconstruction of unstable joints. Common examples include anterior cruciate ligament and collateral ligament reconstructions of the knee, medial and lateral elbow collateral ligament reconstructions, ankle collateral ligament reconstruction, finger and hand collateral ligament reconstructions and the like.

Traditional techniques that are used to fix tendon to bone suffer from a number of limitations as a result of the methodology used, including the use of a "keyhole" tenodesis, pull-out sutures, bone tunnels, and interference screw fixation. The "keyhole" tenodesis requires the creation of a bone tunnel in the shape of a keyhole, which allows a knotted tendon to be inserted into the upper portion, and subsequently wedged into the lower narrower portion of the tunnel where inherent traction on the tendon holds it in place. This technique is challenging as it is often difficult to sculpt the keyhole site and insert the tendon into the tunnel. In addition, if the tendon knot unravels in the postoperative period, the tendon will slide out of the keyhole, losing fixation.

Another traditional form of tendon fixation is the use of the "pull-out stitch." With this technique, sutures attached to the tendon end are passed through bone tunnels and tied over a post or button on the opposite side of the joint. This technique has lost favor in recent years due to a host of associated complications, which include wound problems, weak fixation strength, and potential injury to adjacent structures.

The most common method of fixation of tendon to bone is the use of bone tunnels with either suture fixation, or interference screw fixation. The creation of bone tunnels is rela-

tively complicated, often requiring an extensive exposure to identify the margins of the tunnels. Drill holes placed at right angles are connected using small curettes. This tedious process is time-consuming and fraught with complications, which include poor tunnel placement and fracture of the overlying bone bridge. Graft isometry, which is easy to determine with single point fixation, is difficult to achieve because the tendon exits the bone from two points. After creation of tunnels, sutures must be passed through the tunnels to facilitate the passage of the tendon graft. Tunnels should be small enough to allow good tendon-bone contact, yet large enough to allow for graft passage without compromising the tendon. This portion of the procedure is often time-consuming and frustrating to a surgeon. Finally, the procedure can be compromised if the bone bridge above the tunnel breaks, resulting in loss of fixation. The technique restricts fixation to the strength of the sutures, and does not provide any direct tendon to bone compression.

More recent advances in the field of tendon fixation involve the use of an internally deployed toggle button, for example, the EndoButton®, and the use of interference screws to provide fixation. The EndoButton, by Smith & Nephew, allows the fixation of tendon into a bone tunnel by creating an internally deployed post against a bony wall. While this technique eliminates the need for secondary incisions to place the post, the fixation strength is limited to suture strength alone. This technique does not provide direct tendon to bone compression; as such this technique may slow healing and lead to graft tunnel widening due to the "bungee effect" and "windshield wiper effect". As a result, this technique has limited clinical applications and is used primarily for salvage when bone tunnels break or backup fixation is important.

The use of the interference screw is the most notable advance in the fixation of tendon to bone. The screw is inserted adjacent to a tendon in a bone tunnel, providing axial compression between the screw threads and the bony wall. Advantages include acceptable pull-out strength and relative ease of use. Aperture fixation, the ability to fix the tendon to bone at its entrance site, is a valuable adjunct to this technique as it minimizes graft motion and subsequent tunnel widening. Some disadvantages related to soft tissue interference screws are that they can be difficult to use, and can also cut or compromise the tendon during implantation.

The newest generation interference screw allows the ability to provide tendon to bone fixation with limited exposure. For example, the Bio-Tenodesis Screw™ (Arthrex, Inc.) allows the tensioning and insertion of tendon into bone, followed by insertion of an adjacent soft tissue interference screw. While this screw system provides advantages in the insertion of tendon into bone in cases when a pull through stitch is not available, it is still limited by the potential for tendon rotation or disruption as the screw compresses the tendon. The surgical technique is also complicated, typically requiring two or more hands for insertion, making it difficult to use the system without assistance during arthroscopic or open procedures. Finally, the use of the screw requires preparation of the tendon end, which can be difficult, time consuming, and can also require conversion of an arthroscopic procedure to open.

Referring particularly to the field of repairing an anterior cruciate ligament (ACL) injury, current repair techniques utilizing soft tissue for the replacement graft are either difficult to perform or they result in less than favorable outcomes due to their relatively low tendon-to-bone fixation. Existing ACL reconstruction techniques that have acceptable outcomes (high tendon-to-bone fixation strength) require extra operating room time and surgeon effort due to the requirements of

multiple drill holes, external guides and fixtures for the drill holes, and multiple assistants. Another difficulty with current techniques is that they do not well replicate the native ACL in its anatomy or physiology.

Two important factors in replicating the native ACL are aperture compression (compressing the tendon against the bone at the opening of the drill hole into the joint) and tendon length. Compression of the tendons at the aperture of the femoral tunnel will improve the healing process by increasing the intimate contact between the tendon and the bone. Studies show that the lack of intimate contact between the tendon and bone can result in less well organized fibrous tissue, resulting in lower pull-out strengths. The stiffness of the repair is also important to replicate the native ACL. Graft stiffness is decreased by the length of tendon between the fixation points.

Currently, two different sources are utilized for the tissue that replaces the injured native ACL. When the new tissue comes from the patient's own body, the new graft is referred to as an autograft, and when cadaveric tissue is used, the new graft is referred to as an allograft. The most common autograft ACL reconstruction performed currently is the bone-patellar tendon-bone (BTB) graft. The BTB graft fixed with an interference screw is used more often because it more accurately replicates the native ACL, due to its aperture compression at the femoral tunnel aperture. However, BTB reconstructions result in an increased rate of anterior knee pain post-surgically for periods of up to 3 years after the reconstruction. Additionally, the harvest procedure for the BTB autograft is invasive and can be difficult to perform. Alternatively, the hamstring tendon autograft ACL reconstruction technique does not result in any significant post-surgical pain, and the harvest procedure is minimally invasive compared to the BTB graft harvest. The reason that the hamstring tendon autograft procedure is not used more frequently in ACL reconstructions is that the fixation of the hamstring tendons to the femur and tibia are not as strong as the fixation of the BTB autografts.

Many prior art systems have addressed some of the problems associated with ACL reconstruction using hamstring tendons, but there is not one system that addresses them all. For example, the EndoButton system (Smith & Nephew) is easy to use and does not need additional drill holes. However, it does require additional accessories and additional people to perform the procedure and does not replicate the native ACL due to a lack of tendon-to-bone compression at the aperture, as well as additional length of tendon between fixation points. The EndoButton system is an example of a cortical hamstring fixation device that yields a longer graft construct, resulting in a graft that is less stiff than the native ACL. Peer reviewed journal data show that existing soft tissue fixation systems with long graft lengths between fixation points have as much as a 56% reduction in graft stiffness when compared to the native ACL.

The RigidFix® product by Mitek is a cross pin device that requires multiple drill holes, additional instruments, and assistance from other people in the operating room to complete the repair. Also, there is only passive compression of tendon to bone, not direct, active compression.

The Stratis® ST product by Scandius attempts to more accurately replicate the native ACL by adding material to take up space in the femoral tunnel resulting in more intimate contact between the tendon and the bone. However, to insert the device into the femoral tunnel, the cross-sectional area must be less than the cross-sectional area of the hole. Thus, there is no real compression of tendon to bone. The Stratis ST product also requires additional drill holes, accessories, and people to properly perform the procedure.

The EZLOC™ product by Arthrotek provides high strength and attempts to more accurately replicate the native ACL in the same fashion as the Stratis ST product, by taking up the space in the femoral tunnel. This does create more intimate contact between the tendon and bone, but does not offer real compression at the aperture.

Interference screws such as the RCI™ Screw, available from Smith & Nephew, are easy to use and provide compression of tendon to bone at the femoral tunnel aperture. However, the pull-out strength and stiffness of the repair are significantly lower than the preceding systems.

Thus, although there are many conventional techniques used for the fixation of tendon to bone, each having some advantages, the disadvantages of each such technique presents a need in the art for a simple and universal technique to fixate tendon to bone such that the device is easy to use, the process is simple to follow, and the result is a firm and secure tendon to bone fixation with minimal negative effect on the tendon. Further, such device should be easy to manufacture, universally applied to different tendon to bone sites, and require minimal effort to understand and use in practice.

SUMMARY OF THE INVENTION

The present invention is a device that is easy to use, provides high fixation of tendon-bone and active tendon-bone compression, requires no additional accessories, uses only one drill hole, and can be implanted by one practitioner. The invention utilizes cancellous bone for fixation, and replicates the native ACL by compressing the tendons against the bone at the aperture of the femoral tunnel, effectively shortening the length of the graft as compared to cortical hamstring fixation devices. An important advantage of the invention is the improvement of the tendon-bone fixation of hamstring autografts as well as other soft-tissue ACL reconstruction techniques. Extra graft length is eliminated by compression of the tendon against the bone at the aperture of the femoral tunnel, which more closely replicates the native ACL and increases graft stiffness. The inventive device provides high fixation of tendon to bone and active tendon-bone compression. Graft strength has been found to be greater than 1,000 N (Newtons), which is desirable for ACL reconstruction systems.

More particularly, there is provided in one aspect of the invention a material fixation system, which comprises an implant which is placeable in a tunnel disposed in a portion of bone, wherein the tunnel is defined by walls comprised of bone. A first member is deployable outwardly to engage the tunnel walls for anchoring the implant in place in the tunnel, and a second member is deployable outwardly to engage tissue material to be fixed within the tunnel. The second member also functions to move the tissue material outwardly into contact with the tunnel walls. A third member forming a part of the implant is movable to deploy the first member outwardly. A fourth member is provided actuating the third member to move in order to deploy the first member.

Preferably, the fourth member comprises a portion which functions to deploy the second member outwardly. The implant comprises a body having a distal end and a proximal end, and the first member is disposed on the body. The first member comprises an arm which is pivotally attached to the body. The third member comprises a wedge which is movable generally axially to deploy the arm.

In one presently preferred embodiment, the fourth member comprises a deployment screw having a distal end and a proximal end, wherein the deployment screw is adapted to extend axially through the body. The distal end of the deploy-

5

ment screw has a threaded portion which is engageable with a complementary threaded portion on the wedge, wherein rotation of the deployment screw causes relative movement of the deployment screw and the wedge. The wedge moves proximally to deploy the arm.

The aforementioned second member comprises a compression pad. In the preferred embodiment, the fourth member portion comprises a head of the deployment screw, disposed on the proximal end thereof.

In another aspect of the invention, there is provided an anchor for securing soft tissue into a portion of bone, which comprises a body portion having a distal end and a proximal end. At least one outwardly deployable anchoring member is disposed on the body. A wedge member is movable for deploying the at least one outwardly deployable anchoring member. The anchor further comprises a generally axially movable deploying member for moving the wedge member. The deploying member engages the wedge member to move the wedge member, and is disposed proximally of the wedge member.

Preferably, the aforementioned wedge member is disposed distally of the outwardly deployable anchoring member, and moves proximally in order to deploy the outwardly deployable anchoring member outwardly. The anchor further comprises an outwardly deployable compression member for engaging a portion of soft tissue and pushing the soft tissue outwardly into contact with adjacent bone. The outwardly deployable compression member is proximal to the outwardly deployable anchoring member. A portion of the generally axially movable deploying member is adapted to deploy the compression member outwardly. Again, referencing currently preferred embodiments, the at least one outwardly deployable anchoring member comprises an arm pivotally attached to the body, and the generally axially movable deploying member comprises a threaded deployment screw.

In yet another aspect of the invention, there is provided an implant system for use in making an orthopedic repair of a joint, which comprises a first implant adapted for receiving a tissue graft thereon and then being disposed in a first bone tunnel location, wherein ends of the tissue graft extend through a bone tunnel and out of a proximal end of the tunnel. The first implant comprises a body portion having a distal end and a proximal end, and a first member disposed on the body portion which is deployable outwardly to engage adjacent bone for anchoring the implant in place in the tunnel. The first implant further comprises a second member disposed on the body portion which is deployable outwardly to engage tissue material to be fixed within the tunnel, and to move the tissue material outwardly into contact with the tunnel walls. The implant system further comprises a second implant adapted for disposition in a second bone tunnel location, proximal to the first bone tunnel location. The second implant is adapted to secure the ends of the tissue graft which extend from the first implant against adjacent bone. The first implant further comprises a third member which is movable to deploy the first member outwardly. A fourth member is provided for actuating the third member to move in order to deploy the first member.

In still another aspect of the invention, there is disclosed a method of making an orthopedic repair by fixing a soft tissue graft to bone, which comprises steps of placing a soft tissue graft on an implant, and disposing the implant within a bone tunnel at a desired location, such that a plurality of ends of the soft tissue graft extend from the implant in a proximal direction through the bone tunnel. Additional steps include deploying a first member on a body of the implant outwardly so that portions of the first member engage adjacent bone to secure

6

the implant in place at the desired location, and deploying a second member on the body of the implant outwardly, so that portions of the second member engage portions of the plurality of ends of the soft tissue graft and push the soft tissue graft ends into contact with adjacent bone.

The invention, together with additional features and advantages thereof, may best be understood by reference to the following description taken in conjunction with the accompanying illustrative drawing.

BRIEF DESCRIPTION OF THE DRAWINGS

FIG. 1 is an isometric view of an embodiment of a device constructed in accordance with the principles of the present invention;

FIG. 2A is a top view of the device of FIG. 1 in an undeployed configuration;

FIG. 2B is a side view of the device of FIG. 2A;

FIG. 3A is a top view of the device of FIG. 1, wherein the deployment screw is starting to deploy the compression pads;

FIG. 3B is a side view of the device of FIG. 3A;

FIG. 4A is a top view of the device of FIG. 1, wherein the compression pads have been fully deployed;

FIG. 4B is a side view of the device of FIG. 4A;

FIG. 5 is a top view of the device of FIG. 1, wherein the wedge is starting to deploy the arms;

FIG. 6 is a top view of the device of FIG. 1, wherein the wedge is halfway engaged;

FIG. 7A is a top view of the device of FIG. 1, wherein the implant has been fully deployed;

FIG. 7B is a side view of the device of FIG. 7A;

FIG. 8 is a view illustrating the implant of FIG. 1, as it is deployed in the femoral tunnel of a patient;

FIG. 9A is a view illustrating tendon compression as effected by the embodiment of FIGS. 1-7;

FIG. 9B is a detail view of a portion of FIG. 9A denoted by a circle labeled as "9B";

FIG. 10 is a perspective view, in isolation, of a deployment screw for use in the embodiment of FIGS. 1-7;

FIG. 11A is a perspective view of a compression pad for use in the embodiment of FIGS. 1-7;

FIG. 11B is a perspective view of a second compression pad;

FIG. 12 is a perspective view of the body of the implant of FIGS. 1-7;

FIGS. 13A and 13B are perspective views of arms for use in the embodiment of FIGS. 1-7;

FIGS. 14A and 14B are perspective views of the wedge for use in the embodiment of FIGS. 1-7;

FIGS. 15A and 15B are perspective views of modified embodiments of the implant of FIGS. 1-7 with arms flipped to engage with the cortical surface during a soft tissue repair procedure;

FIGS. 16A and 16B are perspective views of yet another embodiment of the implant of the invention, wherein the body is used as the wedge;

FIG. 17 is a table summarizing the performance of an implant constructed in accordance with the principles of the present invention, as shown in FIGS. 1-7;

FIG. 18 is an isometric view of a further modified embodiment of the invention;

FIG. 19 is an exploded view of the embodiment of FIG. 18;

FIG. 20 is a plan view of the embodiment of FIG. 18, in an undeployed configuration;

FIG. 21 is a side view of the embodiment of FIG. 20;

FIG. 22 is a plan view of the embodiment of FIG. 20, wherein the deployment screw is starting to deploy the compression pads;

FIG. 23 is a side view of the embodiment of FIG. 22;

FIG. 24 is a view illustrating the implant of FIGS. 18-23 deployed in a femoral tunnel;

FIG. 25 is a detailed view similar to FIG. 24, showing tendon compression performed by the deployed inventive device;

FIG. 26 is a perspective view of the deployment screw;

FIG. 27 is a view showing the body of the implant;

FIG. 28 is a view similar to FIG. 27, but showing the implant from a different orientation;

FIG. 29 is an isometric view of an arm in accordance with the invention;

FIG. 30 is an isometric view from a different orientation than FIG. 29, showing the arm;

FIG. 31 is a view of the wedge of the invention;

FIG. 32 is a data table;

FIG. 33 is an isometric view of another embodiment of the invention, comprising an undeployed cortical fixation implant;

FIG. 34 is an isometric view of the cortical fixation implant of FIG. 33, from a different orientation;

FIGS. 35 and 36 are top and side views, respectively, of the cortical implant of FIGS. 33 and 34;

FIGS. 37 and 38 are top and side views, respectively, of the cortical implant of FIGS. 33 and 34, wherein the implant is beginning to be deployed;

FIGS. 39 and 40 are top and side views, respectively, of the cortical implant of FIGS. 37 and 38, wherein the implant is in a deployed state;

FIGS. 41 and 42 show a deployment sequence for the cortical fixation implant;

FIG. 43 is an isometric view of the body of the implant of FIG. 33, showing integrated compression pads;

FIG. 44 is a cross-sectional view of the body of FIG. 43, taken along the lines 44-44 of FIG. 45;

FIG. 45 is a side view of the implant of FIG. 43;

FIG. 46 is a perspective view of the wedge of the invention;

FIGS. 47 and 48 are views of the arm of the invention;

FIG. 49 is a perspective view of the compression wedge of the invention;

FIG. 50 is a perspective view of the deployment screw of yet another embodiment of the inventive implant; and

FIGS. 51-52 are isometric views of an additional embodiment of a cortical implant of the invention, wherein FIG. 51 shows the device in its undeployed configuration and FIG. 52 shows the device in its deployed configuration;

FIGS. 53-54 are isometric views of still another embodiment of a cortical implant of the invention, wherein FIG. 53 shows the device in its undeployed configuration and FIG. 54 shows the device in its deployed configuration; and

FIG. 55 is a view of the femur and tibia of a patient's leg, showing a substantially completed ACL repair.

DETAILED DESCRIPTION OF THE INVENTION

Referring now more particularly to the drawings, procedures and anchoring devices for repairing soft tissue are illustrated. In FIG. 1, one embodiment of an implant 10, constructed in accordance with the principles of the present invention, is shown. The implant 10 comprises a deployment screw 12, which protrudes through a pair of compression pads 14 and 16. The implant 10 comprises a body 18, through which the deployment screw 12 also protrudes. The deployment screw 12, at its distal end, is threaded into a wedge 20.

The left compression pad 14 slides into the right compression pad 16, and they attach to one another. Two pins 22 attach a pair of arms 24 to the body 18. There is a track 26 on each side of the wedge 20, best seen in FIG. 14A. Each wedge track 26 attaches to a track post 28 (FIG. 13B) on a corresponding one of the arms 24. The wedge tracks 26 function to prevent the wedge from rotating during deployment of the implant.

The compression pads 14, 16 slide into a pair of body tracks 30 (FIG. 12) in the body 18, which allow the pads 14, 16 to expand when the deployment screw 12 is rotated clockwise, as shown in FIGS. 2-4. The body tracks 30 also prevent the pads 14, 16 from rotating.

In FIG. 10, the deployment screw 12 is shown in detail. This screw 12 comprises a quad lead section 32, with four separate thread starts. This means that, for every single turn on the screw, the linear distance it travels is four times what a single lead screw would be. This feature enables the user to turn the screw fewer times than would be required with a single start thread, approximating the same number of turns that the user would need during the implantation of an interference screw such as the above described Smith & Nephew RCI screw. Often, during implantation, an interference screw requires a notch to be placed at the edge of the femoral tunnel aperture to allow the screw to start engaging into the bone. Advantageously, the need for this step is eliminated when deploying the implant of the present invention, resulting in a substantially easier implementation procedure.

Accordingly, the present invention is easy to deploy as an interference screw, and requires fewer steps than in prior art approaches. The deployment screw 12 also provides a rigid backbone to support the implant. A screw head or compression pad deployer 34 deploys the compression pads 14, 16 as the screw 12 moves axially into the implant. Another feature of the screw 12 is a load transfer disk 36 that transfers some of the axial load from a junction between the screw head 34 and the body 18 to a junction between the load transfer disk 36 and the body 18. This load transferring feature allows for thinner side walls or struts 38 on the body 18 due to a decreased load on struts 38 (FIG. 12), which, in turn, allows a larger tendon to fit between the deployment screw 12 and the body 18.

With reference now particularly to FIGS. 11A and 11B, the compression pads 14 and 16 are shown in greater detail. The left and right compression pads 14, 16, respectively, compress the tendons against the femoral tunnel wall to promote tendon-to-bone healing at the aperture of the tunnel. Unlike current approaches for more intimate tendon-to-bone contact that only reduce the space between the tendon and the tunnel wall, the present invention actively compresses the tendons against the bone tunnel. Compression pad tracks 40 engage the body tracks 30 and interlock them to the body 18. This joint also provides torsional resistance while moving the implant into place, and during initial deployment until the arms 24 start to engage with the bone. There are engagement slots 42 in each compression pad 14, 16, as shown, that engage with a deployment device that keep the implant 10 from rotating until the arms 24 engage the bone. The two compression pads 14, 16 snap together using compression pad snaps 44 to prevent premature deployment of the pads.

Now referring to FIG. 12, the body 18 functions to trap the tendons on either side of the deployment screw 12. The compression pads 14, 16 engage the body tracks 30 and provide torsional strength to the body while inserting the implant into the femoral tunnel, thus allowing the compression pads 14, 16 to expand parallel to one another. The struts 38 also provide structural support for the deployment screw 12, wedge 20, and arms 24 to deploy against.

The arms **24** have a few key design features, as best shown in FIGS. **13A** and **13B**. Fins **46** on the top of each arm provide torsional strength for the wedge-to-arm junction. The fins **46** also allow easier insertion into the femoral tunnel when inserting into a femoral tunnel that is drilled off-axis from the tibial tunnel. The portion of the arm **24** that engages with the bone has a tapered edge **48** which allows for ease of bone displacement during deployment. A support rib **50** disposed along the length of the arm **24** is also tapered for ease of bone displacement, and provides structural support during axial loading. Torsion pins **52** engage with a torsion hole **54** to provide additional torsional strength while the implant is being implanted into the femoral tunnel.

FIGS. **14A** and **14B** show, in greater detail, particular constructional features of the wedge **20**. The wedge **20** is threaded with a female quad lead thread **56** that matches the male quad lead thread **32** of the deployment screw **12**. The track posts **28** engage with the wedge tracks **26** to provide torsional strength through deployment. A tapered nose **58** on the wedge **20** allows easier off-axis insertion into the femoral tunnel.

Referring now to FIGS. **2-9**, a preferred method of using the disclosed inventive implant will now be discussed. In FIGS. **2A** and **2B**, the implant **10** of FIG. **1** is shown in its undeployed orientation. A preferred procedure for deploying the implant is generally similar in many respects to the procedure disclosed in U.S. Patent Application Publication No. 2006/0155287, herein already expressly incorporated by reference.

Thus, to accomplish tendon fixation using the exemplary methods and devices described herein, standard surgical preparation of the site and/or arthroscopic portals for access to the procedural region are performed. The joint is dilated with arthroscopic fluid if the procedure is to be performed arthroscopically. With open procedures, the device may easily be manipulated and deployed with a single hand. For arthroscopic procedures, the deployment device is introduced through a standard 5, 6, or 8 mm cannula placed into the joint. A range of preferred cannula sizes would be 2-11 mm.

The procedures described herein are specifically adapted to repair of the ACL in a patient's knee. However, it should be kept in mind that the implants described herein may be used in numerous other soft tissue repair applications, using surgical procedures which are adapted to those applications.

FIGS. **8** and **9A** illustrate, from two different orientations, a hamstring ACL reconstruction, wherein the implant **10** is utilized to secure the ACL graft proximal to the femur **60** and distal to the tibia **62** of a patient. To deploy the implant **10**, a bone tunnel **64** is drilled completely through the tibia **62** and partially through the femur **60**. An actuator (not shown) is employed to insert the implant **10** distally through a tibial inlet aperture **66** and through the tibial tunnel **64**, so that the implant is finally disposed in a portion of the tunnel **64** which is within the femur **60**, distal to a femoral aperture **68**, as shown in FIGS. **8** and **9A**.

Now with respect to FIGS. **3** and **3A**, once the implant **10** is in place within the femoral tunnel **64**, as shown in FIG. **8**, the deployment screw **12** is actuated (rotated) in order to advance the screw **12** axially distally into the implant body **18**, and thus begin to deploy or expand the compression pads **14** and **16** outwardly. FIGS. **4** and **4A** depict the next step, wherein advancement of the deployment screw **12** has caused the compression pads **14**, **16** to fully deploy. As noted above, the screw head or compression pad deployer **34** acts to deploy the compression pads **14**, **16** as it moves distally into the implant **10**, as shown.

As the deployment screw **12** continues to move distally through the implant **10**, the distal end of the screw **12**, comprising the male quad lead section **32** (FIG. **10**), engages the female quad lead thread **56** of the wedge **20** (FIG. **14B**). Continued axial distal movement of the screw **12** causes the threaded sections **32** and **56** to cooperate to move the wedge **20** axially in a proximal direction, as shown in FIG. **5**. This proximal movement of the wedge **20** causes the arms **24** to begin to deploy outwardly. In FIG. **6**, the wedge **20** is shown in a position where it is about halfway engaged within the separating arms **24**.

In FIGS. **7A** and **7B**, the wedge **20** is fully proximally engaged with the body **12** of the implant **10**, such that the arms **24** are, consequently, fully deployed. In FIG. **8**, the implant **10** is shown in this fully deployed condition.

FIGS. **9A** and **9B** illustrate tendon compression as effected by the deployed implant **10**. In these figures, tendons **70** are compressed by deployed compression pads **14**, **16** against the femoral tunnel wall in order to promote tendon-to-bone healing at the aperture of the tunnel. Advantageously, the inventive approach actively compresses the tendons against the bone tunnel.

Alternative implant designs are shown in FIGS. **15** and **16**. In particular, FIGS. **15A** and **15B** illustrate an alternative embodiment (with like elements being labeled with like reference numerals to those used in connection with the embodiment of FIG. **1**) wherein the arms **24** are flipped to the other side of the body **18**. The modified arms **24** are designed to permit the tendons (not shown) to pass by them and engage with the cortical bone. The arm-to-body joint is a pin-less design with a track way in the body that secures the arm **24** in place.

FIGS. **16A** and **16B** illustrate yet another modified embodiment wherein, once again, like elements are labeled with like reference numerals as those used in connection with the earlier embodiments. In this embodiment, the implant **10** uses the body **18** as a wedge.

Testing has been done by the inventors to verify the functionality of the disclosed invention of FIGS. **1-7**. As shown in FIG. **17**, the inventors found that pull-out forces for the implant **10** were significantly higher than those of a predicate device, the RCI interference screw available from Smith & Nephew.

In FIGS. **18-21** there is shown another implant embodiment **110**, wherein like elements are identified with like reference numerals as for the embodiment of FIGS. **1-14**, preceded by the numeral **1**. As shown, the deployment screw **112** protrudes through the compression pads **114** and **116**, which are each integrated into the body **118**. The deployment screw **112** is threaded at its distal end into the wedge **120**. Two pins **122** attach a pair of arms **124** to the body **118**, as shown.

As noted above, in this embodiment the compression pads **114**, **116** are integrated into the body **118**. This feature permits the use of a shorter implant than is the case for the implant of FIG. **1**. A track **126** in the wedge **120** attaches to track posts **128** on the arms **124** (FIG. **29**), which keep the wedge **120** from rotating during deployment. The compression pads expand as the implant is deployed. In particular, the screw **112** expands the pads **114**, **116** outwardly by sliding on a compression taper **72** (FIG. **27**), as shown in FIGS. **20-23**. Moreover, as the deployment screw **112** rotates, the wedge **120** expands the arms **124** as also shown in FIGS. **20-23**. Once the screw **112** is fully seated, the expanded arms **124** fully engage with adjacent cancellous bone **74**, thus locking the anchor in place, as shown in FIG. **24**.

The deployment screw **112** (FIG. **26**) has a male quad lead section **132** with four separate thread starts, as in the prior

11

disclosed embodiment. This means that for every one rotation of the screw, the linear distance it travels is four times that which a single lead screw would travel. This enables the user to turn the screw fewer times than would be required with a single start thread, approximating the same number of turns that the user would need during the implantation of an interference screw such as the RCI screw available from Smith & Newphew. Oftentimes, during implantation, an interference screw such as the RCI screw requires a notch to be placed at the edge of the femoral tunnel aperture to permit the screw to start engaging the bone. However, the present invention avoids the need for such a step, resulting in an easier implantation procedure. The invention is easy to deploy as an interference screw, and requires fewer steps. The deployment screw **112** also provides a rigid backbone to support the implant. A reverse threaded hex **75** is preferably provided to drive the screw.

The screw head or compression pad deployer **134** deploys the compression pads **114**, **116** as the screw **112** advances axially into the implant. Another feature of the screw is the provision of a load transfer disk **136** that transfers some of the axial load from the screw head **134** to body junction to the disk to body junction. This allows for thinner side walls or struts **138** on the body **118** due to the decreased load on the struts, which in turn allows a larger tendon to fit between the deployment screw **112** and the body **118**.

As shown in FIG. **25**, the compression pads **114**, **116** compress the tendons **170** against the femoral tunnel wall to promote tendon-to-bone healing at the aperture of the tunnel. Unlike prior art approaches for more intimate tendon-to-bone contact that only reduce the space between the tendon and the tunnel wall, the present invention actively compresses the tendons against the bone tunnel. The compression pads **114**, **116** in this embodiment are integral with the body **118**.

The body **118** functions to trap the tendons **170** on either side of the deployment screw **112**. The struts **138** are split, as shown at reference numeral **76** (FIG. **28**), to allow the integrated compression pads **114**, **116** to expand and compress the tendon against the bone tunnel. They also provide structural support for the deployment screw **112**, wedge **120**, and arms **124** to deploy against.

The arms **124** include a few key design features, as particularly shown in FIGS. **29** and **30**. Fins **146** on the top provide torsional strength for the wedge **120** to arm **124** junction. They also allow easier insertion into the femoral tunnel when inserting into a femoral tunnel that is drilled off-axis from the tibial tunnel. The portion of the arm **24** that engages with the bone has a tapered edge **148** which allows for ease of bone displacement during deployment. The support rib **150** along the length of the arm **124** is also tapered for ease of bone displacement and provides structural support during axial loading. The torsion pins **152** engage with a torsion hole **154** to provide additional torsional strength while inserting into the femoral tunnel.

As in the prior embodiment, the wedge **120** is threaded with a female quad lead thread **156** that matches the complementary threads **132** on the deployment screw **112**. The track posts **128** on the arms **124** engage with the wedge track **126** to provide torsional strength through deployment. A tapered nose **158** allows easier off-axis insertion into the femoral tunnel.

FIG. **32** is a table similar to that of FIG. **17**, presenting data generated by the inventors which indicates that pull-out forces for the implant **110** were significantly higher than those of a predicate device, the RCI interference screw available from Smith & Nephew.

12

Still another embodiment of the inventive implant is illustrated in FIGS. **33-54**, wherein like elements to those of the prior embodiments are identified by like reference numerals, preceded by the numeral **2**. This embodiment **210** utilizes the cortical bone for fixation in combination with tendon-to-bone compression. In this version of the invention, the deployment screw **212** is offset to one side of the implant **210**, for the purpose of permitting easier passing of tendon through the orifice. This implant deploys in two steps. The deployment screw **212** is rotated clockwise as an arm **78** and wedge **220** slide together across tapered faces **80** (FIG. **46**) and **82** (FIG. **48**) until they lock together with their respective cortical locks **84**, **86**. The wedge **220** and the arm **78** lock into place by filling a majority of the cross section of the femoral tunnel. Thus, the implant is free to move in the femoral tunnel, allowing tactile feedback to ensure engagement of a cortical tab **88** with the cortex.

The screw is then rotated so that it is advanced the remainder of the way, and the compression wedge **90** engages with the compression pads, thereby pressing the tendon against the bone tunnel wall. A track **92**, **94** in the compression pads **214**, **216** and compression wedge **90** prevents the compression wedge from engaging unevenly. A progression of deployment of the implant **210** is illustrated in FIGS. **35-42**. FIGS. **43-50** illustrate various components of the embodiment. In the undeployed state, the arm is engaged with the wedge with the arm's track posts **228** engaging with a T-bar **96** of the wedge **220**. This prevents the arm **78** from moving during insertion. Also, to prevent the wedge **220** from rotating during deployment, the track post **228** is inserted into a torsion slot **100**.

Modified cortical fixation implant designs are illustrated in FIGS. **51-54**. FIGS. **51** and **52** illustrate a modified wedge and only one arm which allows engagement with the cortical bone. FIGS. **53** and **54** illustrate the same embodiments as in FIGS. **51** and **52**, wherein the screw is to one side of the implant.

FIG. **55** has been incorporated into this application to illustrate a substantially completed ACL repair procedure. FIGS. **8** and **9**, as well as FIGS. **24** and **25** and FIGS. **41** and **42**, illustrate the installation of the femoral anchor of the present invention, in various embodiments. However, as one skilled in the art would understand, to complete the repair procedure further steps are necessary. Once the femoral anchor has been deployed and installed, as previously described, the anchored tendons **70** extend proximally from the femoral tunnel through the tibial tunnel and out through tibial aperture **66**. To complete the procedure, a tibial anchor **102** is preferably installed, to anchor the tendon bundles in place, as shown in FIG. **55**. Once this anchor is in place, the proximal ends of the tendon bundles are trimmed to complete the procedure. This portion of the ACL reconstruction procedure is fully explained in co-pending U.S. application Ser. No. 11/725, 981, which has already been fully and expressly incorporated by reference herein. Any suitable tibial anchor **102** may be used in conjunction with femoral anchors of the type disclosed in this application, but the tibial anchors shown and described in the '981 patent application are presently preferred.

Accordingly, although exemplary embodiments of the invention has been shown and described, it is to be understood that all the terms used herein are descriptive rather than limiting, and that many changes, modifications, and substitutions may be made by one having ordinary skill in the art without departing from the spirit and scope of the invention.

13

What is claimed is:

1. A material fixation system, comprising:
an implant comprising a body having a distal end and a proximal end, which is placeable in a tunnel disposed in a portion of bone, wherein the tunnel is defined by walls comprised of bone;
a first member on said body which is deployable outwardly to engage adjacent bone for anchoring said implant in place in the tunnel, the first member having engaging surfaces which extend outwardly relative to remaining portions of the first member; and
a second member on said body and spaced axially from said first member, which is deployable outwardly to engage tissue material to be fixed within said tunnel, and to move the tissue material outwardly into contact with the tunnel walls, the second member having engaging surfaces which are substantially broader and flatter than the engaging surfaces of the first member, for more effectively compressing the tissue material against the tunnel walls without penetrating the tissue;
a third member which is movable to deploy said first member outwardly; and
a fourth member having an enlarged portion which is movable to contact inner sides of the engaging surfaces of the second member to deploy them outwardly, so that outer sides of the engaging surfaces of the second member engage the tissue material to move it outwardly into contact with the tunnel walls.
2. The material fixation system as recited in claim 1, wherein said third member is movable axially to deploy said first member outwardly.
3. The material fixation system as recited in claim 2, wherein said fourth member actuates said third member to move in order to deploy said first member.
4. The material fixation system as recited in claim 3, wherein said fourth member enlarged portion moves axially to deploy said second member outwardly.
5. The material fixation system as recited in claim 3, wherein said first member comprises an arm which is pivotally attached to said body.
6. The material fixation system as recited in claim 5, wherein said third member comprises a wedge which is movable generally axially to deploy said arm.
7. The material fixation system as recited in claim 6, wherein said fourth member comprises a deployment screw having a distal end and a proximal end, said deployment screw being adapted to extend axially through said body, the distal end of said deployment screw having a threaded portion which is engageable with a complementary threaded portion on said wedge, wherein rotation of said deployment screw causes relative movement of said deployment screw and said wedge.
8. The material fixation system as recited in claim 7, wherein said wedge moves proximally to deploy said arm.
9. The material fixation system as recited in claim 1, wherein the engaging surfaces of said second member comprise compression pads.
10. The material fixation system as recited in claim 4, wherein said fourth member enlarged portion comprises a head of said deployment screw, disposed on the proximal end thereof.
11. An implant system for use in making an orthopedic repair of a joint, said implant system comprising:
a first implant adapted for receiving a tissue graft thereon and then being disposed in a first bone tunnel location,

14

- wherein ends of the tissue graft extend through a bone tunnel and out of a proximal end of the tunnel, said first implant comprising:
a body portion having a distal end and a proximal end;
a first member disposed on said body portion which is deployable outwardly to engage adjacent bone for anchoring said implant in place in the tunnel; and
a second member disposed on said body portion which is deployable outwardly to engage tissue material to be fixed within said tunnel, and to move the tissue material outwardly into contact with the tunnel walls;
a third member which is movable to deploy said first member outwardly; and a fourth member having an enlarged portion which is movable to contact inner sides of the second member to deploy them outwardly, so that outer sides of the engaging surfaces of the second member engage the tissue material to move it outwardly into contact with the tunnel walls; and
a second implant adapted for disposition in a second bone tunnel location, proximal to said first bone tunnel location, said second implant being adapted to secure the ends of the tissue graft which extend from the first implant against adjacent bone.
12. The implant system as recited in claim 11, wherein said first implant further comprises a third member which is movable to deploy said first member outwardly.
 13. The implant system as recited in claim 12, and further comprising a fourth member for actuating said third member to move in order to deploy said first member.
 14. A material fixation system, comprising an implant which is placeable in a space defined by bone, said implant comprising:
a body having a distal end and a proximal end;
a first member on said body which is expandable outwardly to engage portions of the bone, the first member having engaging surfaces which extend outwardly relative to remaining portions of the first member;
a second member on said body which is distal to said first member;
said second member being movable in a proximal direction relative to said first member, wherein proximal movement of said second member actuates said first member to expand outwardly to engage the bone, thereby securing the implant in place within the space;
a third member on said body and spaced axially from said first member, which is deployable outwardly to engage tissue material to be fixed within said tunnel, and to move the tissue material outwardly into contact with the tunnel walls, the third member having engaging surfaces which are substantially broader and flatter than the engaging surfaces of the first member, for more effectively compressing the tissue material against the bone without penetrating the tissue; and
a fourth member having an enlarged portion which is movable to contact inner sides of the engaging surfaces of the third member to deploy them outwardly, so that outer sides of the engaging surfaces of the third member engage the tissue material to move it outwardly to compress the tissue material against the bone.
 15. The material fixation system as recited in claim 14, wherein said second member is actuated by application of tension thereon.
 16. The material fixation system as recited in claim 14, wherein said first member comprises an arm which is pivotable outwardly, said arm having a portion which is adapted to engage bone to anchor the body to the bone.

17. The material fixation system as recited in claim 16, wherein said first member comprises a plurality of said arms.

18. The material fixation system as recited in claim 14, wherein said second member comprises part of a deployment device which is movable in a generally axial direction to 5 deploy both said first and third members.

19. The material fixation system as recited in claim 14, wherein the engaging surfaces of said third member comprise compression pads.

* * * * *