

US008647273B2

(12) **United States Patent**
Harra et al.

(10) **Patent No.:** **US 8,647,273 B2**
(45) **Date of Patent:** **Feb. 11, 2014**

(54) **NON-INVASIVE WEIGHT AND PERFORMANCE MANAGEMENT**

(75) Inventors: **David James Harra**, Scotts Valley, CA (US); **Jacquelyn Fuzell**, Reno, NV (US); **Timothy Daniel Casey**, Reno, NV (US)

(73) Assignee: **RF Science & Technology, Inc.**, Reno, NV (US)

(*) Notice: Subject to any disclaimer, the term of this patent is extended or adjusted under 35 U.S.C. 154(b) by 703 days.

(21) Appl. No.: **12/621,475**

(22) Filed: **Nov. 18, 2009**

(65) **Prior Publication Data**

US 2010/0069731 A1 Mar. 18, 2010

Related U.S. Application Data

(63) Continuation-in-part of application No. 11/821,481, filed on Jun. 21, 2007.

(60) Provisional application No. 61/115,767, filed on Nov. 18, 2008, provisional application No. 61/116,417, filed on Nov. 20, 2008, provisional application No. 61/116,959, filed on Nov. 21, 2008, provisional application No. 61/117,056, filed on Nov. 21, 2008.

(51) **Int. Cl.**

A61B 5/00 (2006.01)
G01J 1/42 (2006.01)
G01N 21/00 (2006.01)

(52) **U.S. Cl.**

USPC **600/365**; 250/393; 356/436; 356/39

(58) **Field of Classification Search**

USPC 600/365, 407, 410-411; 356/436, 440, 356/39; 250/339.01-339.12

See application file for complete search history.

(56) **References Cited**

U.S. PATENT DOCUMENTS

3,768,054 A 10/1973 Neugebauer
4,428,366 A 1/1984 Findl et al.
4,582,985 A 4/1986 Löfberg
4,672,346 A 6/1987 Miyamoto et al.
4,679,426 A 7/1987 Fuller et al.
4,765,179 A 8/1988 Fuller et al.
4,801,209 A 1/1989 Wadlow

(Continued)

FOREIGN PATENT DOCUMENTS

EP 0 350 546 A2 1/1990
FR 2 562 785 A1 10/1985

(Continued)

OTHER PUBLICATIONS

Active Spectrum, Inc., "What is Electron Spin Resonance (ESR)?", website <http://www.activespectrum.com/about.html>, available at least by Jul. 30, 2009.

(Continued)

Primary Examiner — Patricia Mallari

Assistant Examiner — Tiffany Weston

(74) *Attorney, Agent, or Firm* — Baker & Hostetler LLP

(57) **ABSTRACT**

Systems and methods for weight and performance management are described. More particularly, an embodiment relates to a system and method of employing a non-invasive, real-time, continuous blood glucose monitoring device to measure glucose levels in a subject. The determined levels are subsequently used to manage the subject's caloric intake and utilization multiple times during the course of a day.

32 Claims, 26 Drawing Sheets

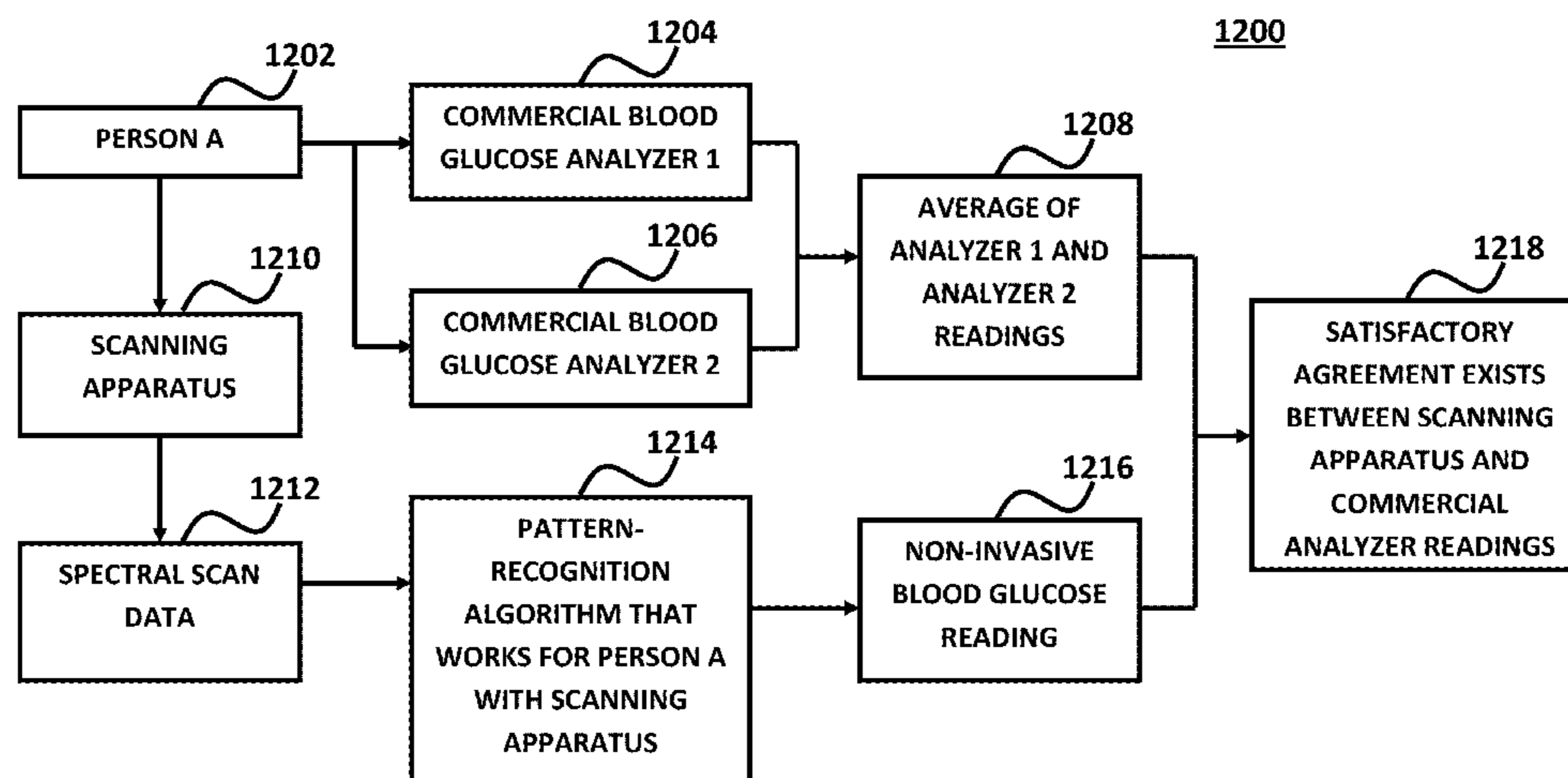

(56)

References Cited

U.S. PATENT DOCUMENTS

4,875,486 A 10/1989 Rapoport et al.
 4,975,581 A * 12/1990 Robinson et al. 250/339.09
 4,993,068 A 2/1991 Piosenka et al.
 5,050,607 A 9/1991 Bradley et al.
 5,063,934 A 11/1991 Rapoport et al.
 5,072,732 A 12/1991 Rapoport et al.
 5,173,661 A 12/1992 Knuttel et al.
 5,320,103 A 6/1994 Rapoport et al.
 5,328,822 A 7/1994 McKinney et al.
 5,348,002 A * 9/1994 Caro 600/310
 5,363,052 A 11/1994 McKee
 5,372,136 A 12/1994 Steur et al.
 5,411,023 A 5/1995 Morris, Sr. et al.
 5,415,163 A 5/1995 Harms et al.
 5,435,169 A 7/1995 Mitra
 5,462,054 A 10/1995 Rapoport et al.
 5,487,870 A 1/1996 McKinney et al.
 5,508,203 A 4/1996 Fuller et al.
 5,565,834 A 10/1996 Hanley et al.
 5,575,977 A 11/1996 McKinney et al.
 5,592,086 A 1/1997 Weinstock et al.
 5,626,137 A 5/1997 Dumoulin et al.
 5,680,460 A 10/1997 Tomko et al.
 5,744,958 A 4/1998 Werne
 5,792,668 A * 8/1998 Fuller et al. 436/149
 5,894,221 A 4/1999 Watanabe et al.
 6,011,858 A 1/2000 Stock et al.
 6,016,476 A 1/2000 Maes et al.
 6,035,398 A 3/2000 Bjorn
 6,038,666 A 3/2000 Hsu et al.
 6,043,881 A 3/2000 Wegrzyn et al.
 6,061,587 A 5/2000 Kucharczyk et al.
 6,107,627 A 8/2000 Nakagawa et al.
 6,110,660 A 8/2000 Kriz et al.
 6,147,490 A 11/2000 Watanabe
 6,184,684 B1 2/2001 Dumoulin et al.
 6,263,228 B1 7/2001 Zhang et al.
 6,309,884 B1 * 10/2001 Cooper et al. 436/14
 6,411,093 B2 6/2002 Schwilch et al.
 6,477,398 B1 11/2002 Mills
 6,480,141 B1 11/2002 Toth et al.
 6,529,617 B1 3/2003 Prokoski
 6,614,238 B1 9/2003 Jean et al.
 6,723,048 B2 * 4/2004 Fuller 600/365
 6,780,378 B2 8/2004 Abbasi et al.
 6,862,466 B2 3/2005 Ackerman
 6,864,826 B1 * 3/2005 Stove 342/22
 6,987,393 B2 1/2006 Jean et al.
 6,995,558 B2 2/2006 Butters et al.
 7,081,747 B2 7/2006 Butters et al.
 7,184,810 B2 2/2007 Caduff et al.
 7,221,169 B2 5/2007 Jean et al.
 7,228,163 B2 6/2007 Ackerman
 7,315,767 B2 1/2008 Caduff et al.
 7,316,649 B2 1/2008 Fuller
 7,347,365 B2 3/2008 Rowe
 7,349,556 B2 3/2008 Brooks
 7,449,695 B2 11/2008 Zimdars et al.
 7,685,433 B2 3/2010 Mantyjari et al.
 7,705,988 B2 4/2010 Richman
 7,781,736 B2 8/2010 Logan, Jr. et al.
 8,259,299 B2 9/2012 Harra et al.
 8,382,668 B2 2/2013 Harra et al.
 2002/0009213 A1 1/2002 Rowe et al.
 2003/0083563 A1 5/2003 Katsman et al.
 2003/0128867 A1 7/2003 Bennett
 2003/0133596 A1 7/2003 Brooks
 2004/0147819 A1 7/2004 Caduff et al.
 2004/0220749 A1 11/2004 Miller et al.
 2005/0090726 A1 * 4/2005 Ackerman 600/347
 2005/0113650 A1 5/2005 Pacione et al.
 2005/0269412 A1 12/2005 Chiu et al.
 2006/0080551 A1 4/2006 Mantyjari et al.
 2007/0237365 A1 10/2007 Monro
 2007/0255141 A1 11/2007 Esenaliev et al.

2007/0290800 A1 12/2007 Fuller
 2008/0057526 A1 3/2008 Caduff et al.
 2008/0192988 A1 8/2008 Uludag et al.
 2008/0319293 A1 12/2008 Looney et al.
 2009/0156915 A1 6/2009 Cross

FOREIGN PATENT DOCUMENTS

GB 1360 606 A 7/1974
 JP 56-14145 10/1981
 WO 99/32897 A2 7/1999
 WO WO0147715 A1 7/2001
 WO WO 2008/156787 12/2008
 WO WO 2010/059744 5/2010

OTHER PUBLICATIONS

Wikipedia, "Electron Paramagnetic Resonance", website http://www.en.wikipedia.org/wiki/Electron_paramagnetic_resonance, available at least by Aug. 12, 2009.

Poor, Alfred, "On the Light Side: Security is All in Vein", website <http://www.ecnmag.com/Lightside-Securty-all-in-Vein-011609.aspx>, Feb. 2, 2009.

Falco et al., Abstract: "Approaching the inverse problem of the multi-layer skin system", Solianis Monitoring AG, Zurich Switzerland; and Applied Physics Dept., The Hebrew University of Jerusalem, Israel, 2008.

Caduff, et al., Abstract: Non-invasive Glucose Monitoring in Patients with Type 1 Diabetes: Repeatability in the same Subjects, R&D, Solianis Monitoring, Zurich Switzerland, Seminar for Statistics, ETH Zurich, Zurich, Switzerland, Centre for clinical research, University Hospital Zurich, Zurich, Switzerland, Clinic for Endocrinology and Diabetes, University Hospital Zurich, Zurich Switzerland and Research, Profil Institute for Metabolic Research, Neuss, Germany, 2008.

Caduff et al., Abstract: "Testing a Multisensor Concept under Simulated Home Use Conditions for non invasive Glucose Monitoring", Solianis Monitoring AG, Zurich Switzerland, Centre for clinical research, University Hospital Zurich, Zurich, Switzerland, Clinic for Endocrinology and Diabetes, University Hospital Zurich, Zurich, Switzerland and Seminar for Statistics, ETH Zurich, Switzerland 2008.

Livshits et al., Abstract: "The Study of the Dielectric Response of Red Blood Cells to Sugar Exposure—In vitro Basis for Non-invasive Glucose Impedance Monitoring", Department of Applied Physics, The Hebrew University of Jerusalem, Jerusalem, Israel, and Solianis Monitoring AG, Zurich, Switzerland, 2008.

Huber et al., Abstract: "The Compensation of Perturbation Effects in Glucose Monitoring Technologies Based on Impedance Spectroscopy", Solianis Monitoring, Zurich, Switzerland; Swiss Federal Laboratories for Materials Testing and Research, St. Gallen, Switzerland; Cantonal Hospital of St. Gallen, St. Gallen, Switzerland; and Institute for Clinical Research and Development, Mainz, Germany, 2008.

Pene, Matt, "Baylor Researcher Creates New Way to Test Blood-Sugar Level", Baylor University website <http://www.baylor.edu/pr/news.php?action=story&story=49271>, Feb. 18, 2008.

Pindi, "Non-Invasive Diagnostics for Measuring Blood and Protecting Identity" (Pindi existing website, including technology presentations, slide show: medical uses for RMM, slide show II: personal security with RMM and all related materials), website download <http://pindi.com/>, Apr. 19, 2007.

Smith, John L., Article: "The Pursuit of Non-Invasive Glucose: Hunting the Deceitful Turkey", copyright 2006.

Caduff et al., Abstract: "Non invasive Glucose Monitoring—Next steps in an approach to address perturbing effects in an IS based monitoring technique", ADA Abstract 2006 Solianis, Zurich, Switzerland, 2006.

Caduff et al., Abstract: "Variations in Blood Glucose and their impact on various Blood Parameters in Healthy Subjects", DTM, Solianis Monitoring, Zurich, Switzerland and Profil Inst. For Metabolic Research, Neuss, Germany, 2006.

Talary et al., Abstract: "Biological application of impedance spectroscopy for in vivo life sign and Non invasive Glucose Monitoring",

(56)

References Cited

OTHER PUBLICATIONS

Biodielectrics, Solianis Monitoring AG, Zurich, Switzerland, 2006.
Livshits et al., Abstract: "The Study of the Dielectric Response of Red Blood Cells to Sugar Exposure—In vitro Basis for Non-invasive Glucose Impedance Monitoring", Department of Applied Physics, The Hebrew University of Jerusalem, Jerusalem, Israel and Solianis Monitoring AG, Zurich, Switzerland, 2005.

Active Spectrum, Inc., "Benchtop Micro-ESR", product literature, San Carlos, California, available no earlier than 2005.

Westerhoff et al., "Mechanisms for the interaction between nonstationary electric fields and biological systems II. Nonlinear dielectric theory and free-energy transduction", *Ferroelectrics*, 1988, vol. 86, pp. 79-101, Gordon and Breach Science Publishers S.A. United States of America, Oct. 1, 1988.

Furukawa et al., "Measurements of Nonlinear Dielectricity in Ferroelectric Polymers", *Japanese Journal of Applied Physics*, 1987, vol. 26, No. 7, pp. 1039-1045, Japan, Apr. 25, 1987.

Liszi et al., "Field-dependent Kirkwood Factor in the Non-linear Dielectric Behaviour of Binary Liquid Mixtures", *J. Chem. Soc., Faraday Trans. 1*, 1982, vol. 78, pp. 915-922.

Author Unknown, "RealStream technology related to industrial analysis application:", Excerpt from yet2.com, website download, date unknown.

Meszarous et al., "Applicability of the Intermodulation Technique for the Nonlinear Behavior of Dielectric Materials", publication information unknown, date unknown. This reference was cited in an earlier filed provisional application by Milton Fuller who is deceased. A copy of this reference cannot be found in the assignee's or inventors files available to assignee and the reference no longer appears to be available to the public. Applicants' and their counsel's knowledge of this reference is limited to its citation in the provisional application.

Kell, D., Title and publication information unknown, date unknown. This reference was cited in an earlier filed provisional application by

Milton Fuller who is deceased. A copy of this reference cannot be found in the assignee's or inventor's files available to assignee and the reference no longer appears to be available to the public. Applicants' and their counsel's knowledge of this reference is limited to its citation in the provisional application.

Gulich et al., "Dielectric spectroscopy on aqueous electrolytic solutions", *Radiat Environ Biophys* 48, pp. 107-114, 2009.

Gilbert et al., "Kinetic EPR studies of the addition of carbohydrate-derived radicals to methacrylic acid", *J. Chem. Soc., Perkin Trans. 2*, pp. 1565-1572, 1998.

Mathur et al., "Dielectric Spectroscopy: Choosing the Right Approach", website <http://license.icopyright.net/user/viewFreeUse.act?fuid=Njc0MDkzOA%3D%3D>, PharmTech.com. Sep. 2008. Available at least by Jan. 9, 2010.

Feldman et al., "Time domain dielectric spectroscopy. A new effective tool for physical chemistry investigation", *Colloid and Polymer Science*, vol. 270, pp. 768-780, 1992.

Fruhstorfer, Heinrich, Heinrich, "Frequent lancing for monitoring blood glucose may cause skin changes", *Pract Diab Int* vol. 23 No. 5, Marburg, Germany, Jun. 2006.

Gottman et al., "Self-Monitoring Effects in a Program for Potential High School Dropouts: A Time-Series Analysis", *Journal of Consulting and Clinical Psychology*, vol. 39, No. 2, pp. 273-281, 1972.

Baker, et al., "Self-Monitoring May Be Necessary for Successful Weight Control", *Behavior Therapy* 24, pp. 377-394, 1993.

Schnoll, et al., "Self-regulation training enhances dietary self-efficacy and dietary fiber consumption", *Journal of the American Dietetic Association*, vol. 101, No. 9, pp. 1006-1011, Sep. 2001.

Kopelman, Peter G., "Obesity as a medical problem", *Nature*, vol. 404, pp. 635-643, Apr. 2000.

Shim Coils, 2011. *Dorland's Illustrated Medical Dictionary*, 2 pages. Retrieved online on Mar. 31, 2013 from <<<http://www.credoreference.com>>>.

* cited by examiner

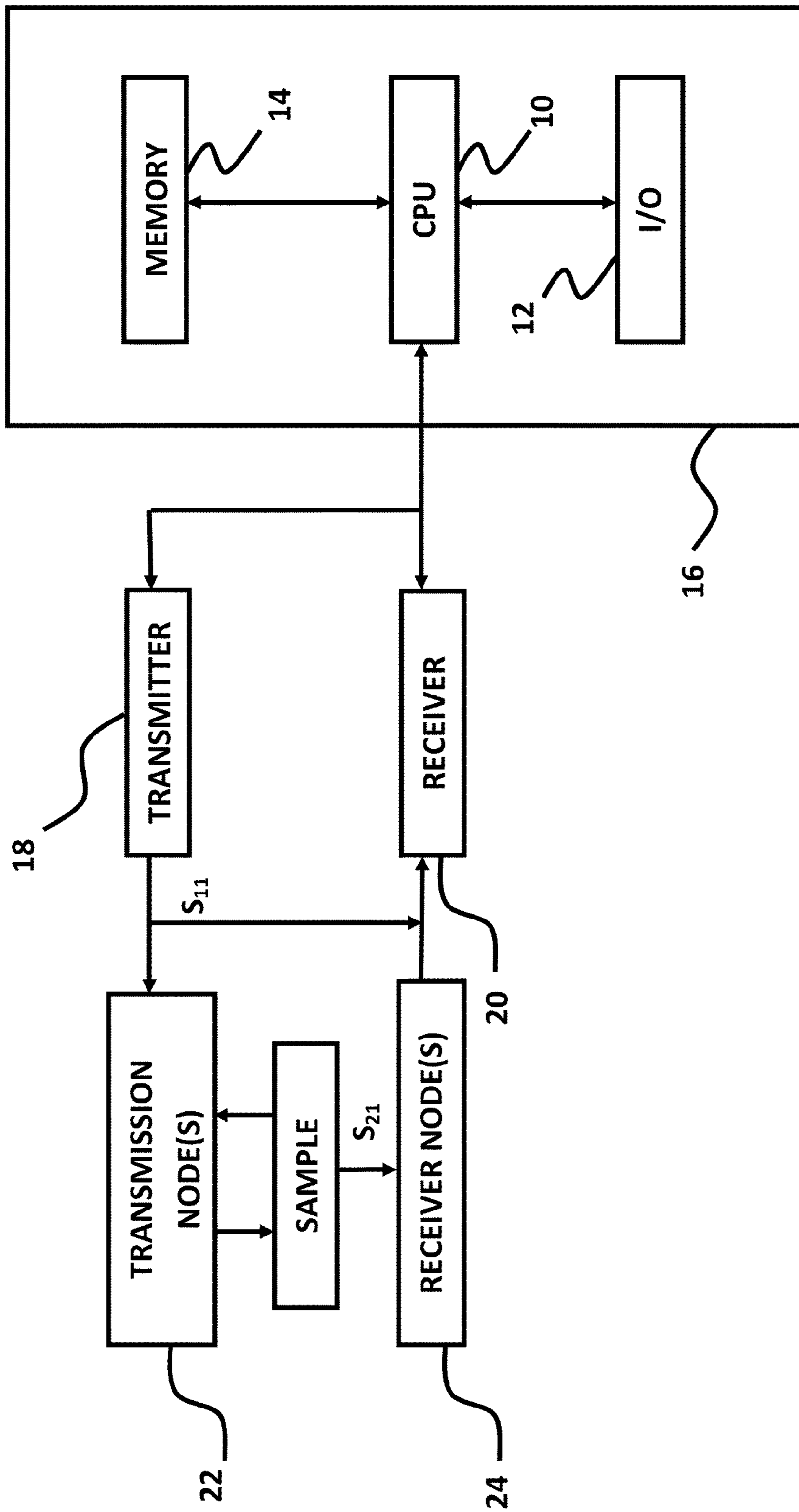

FIG. 1

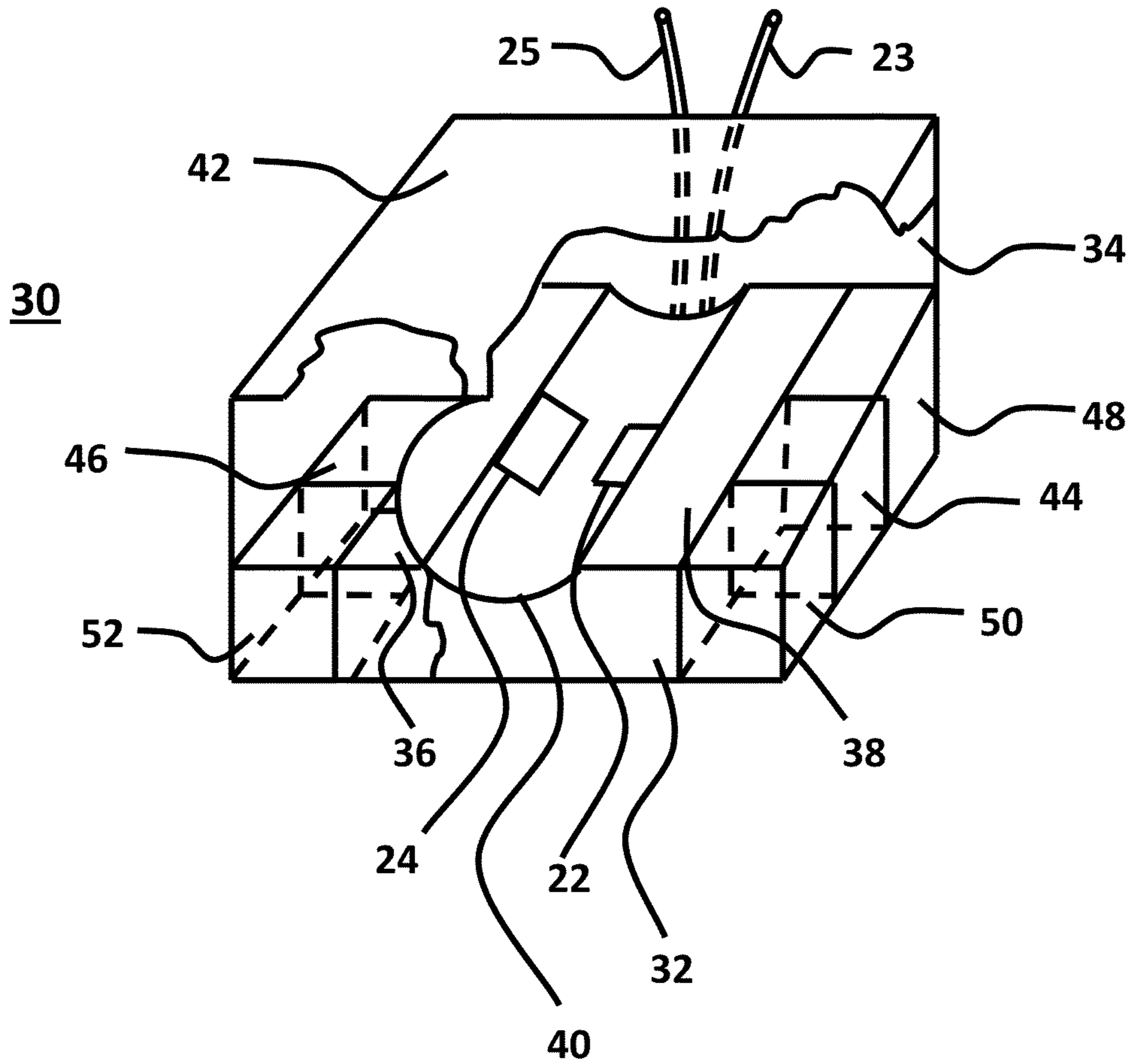

FIG. 2

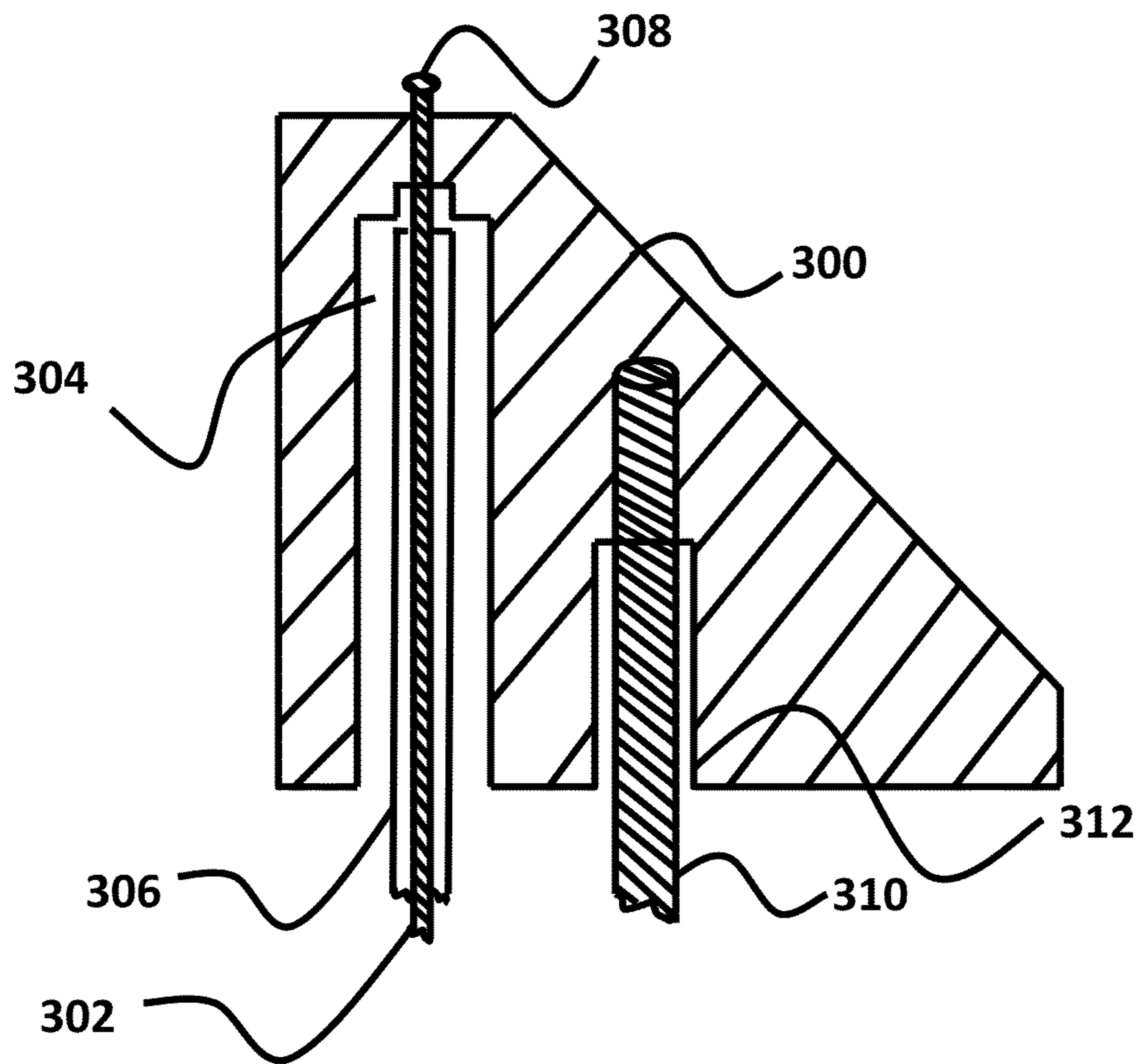

FIG. 3

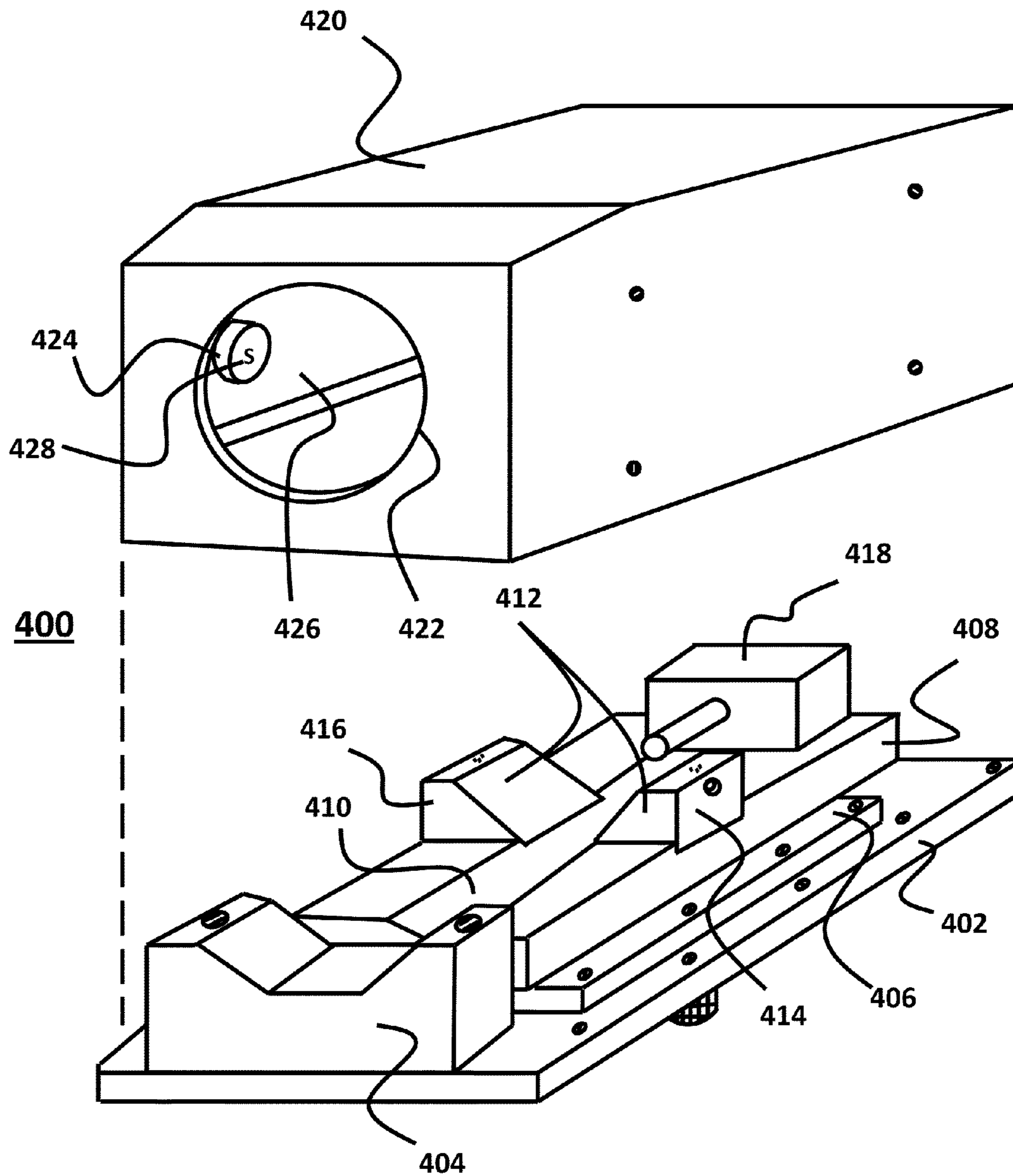

FIG. 4A

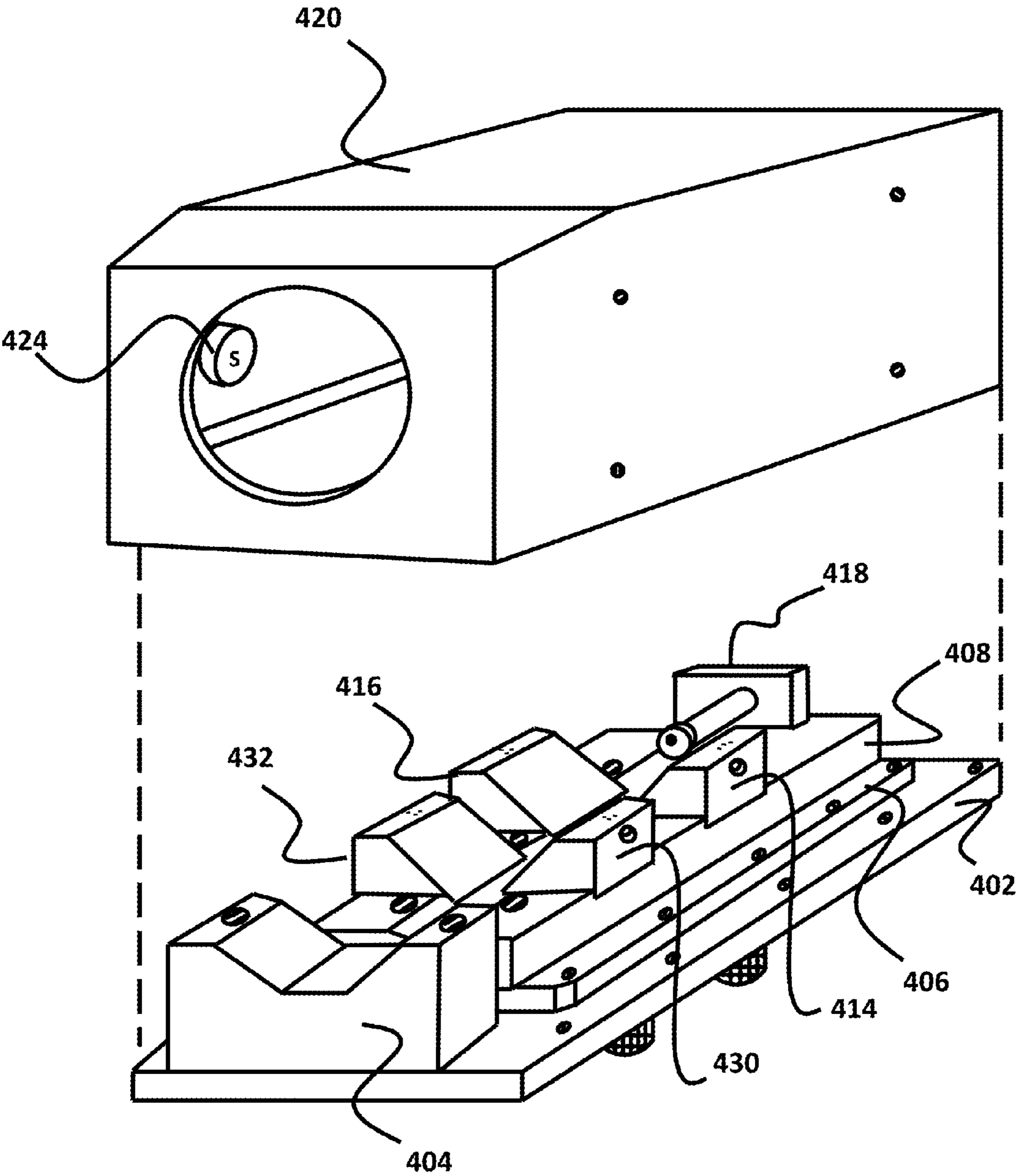

FIG. 4B

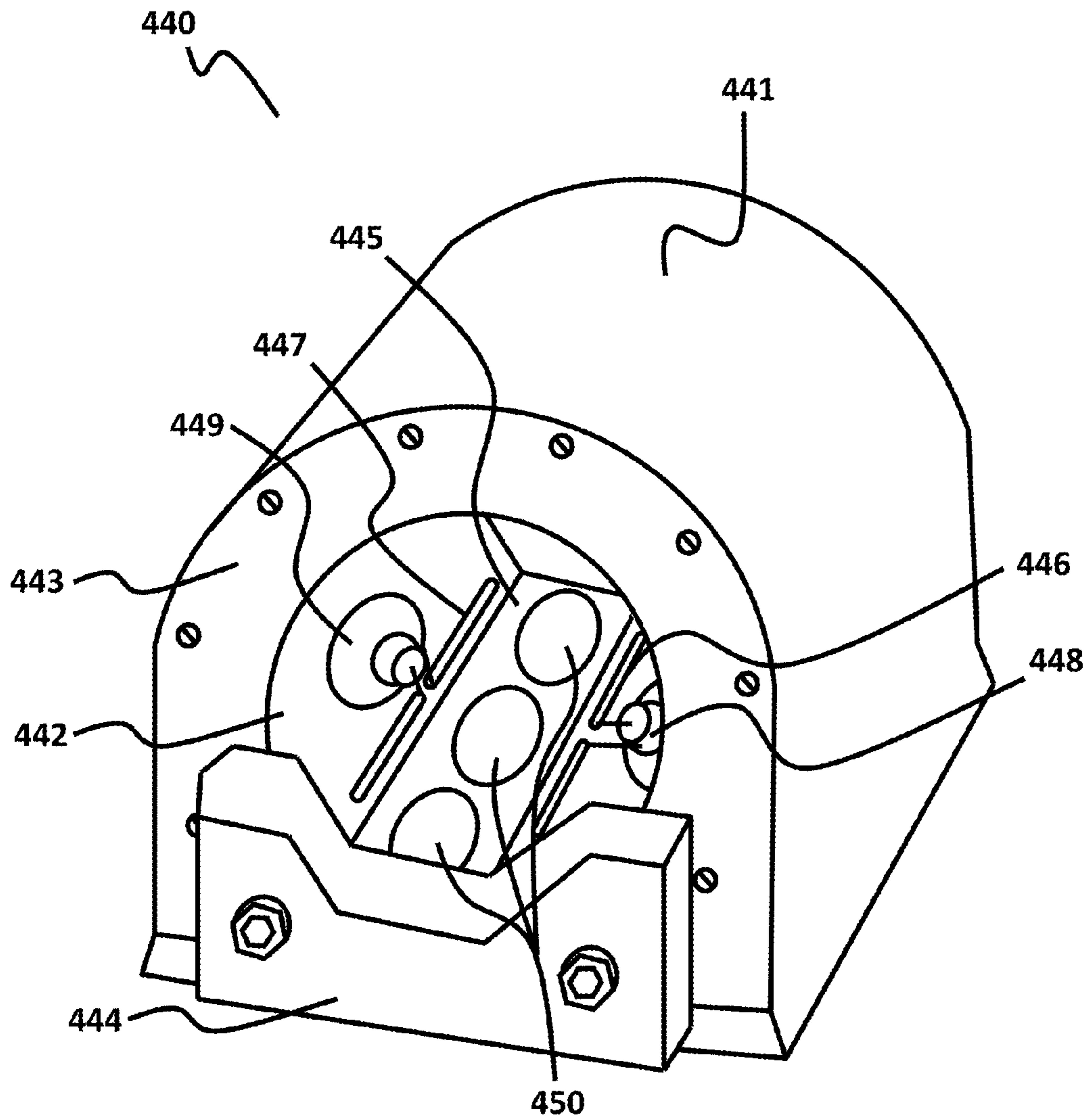

FIG. 4C

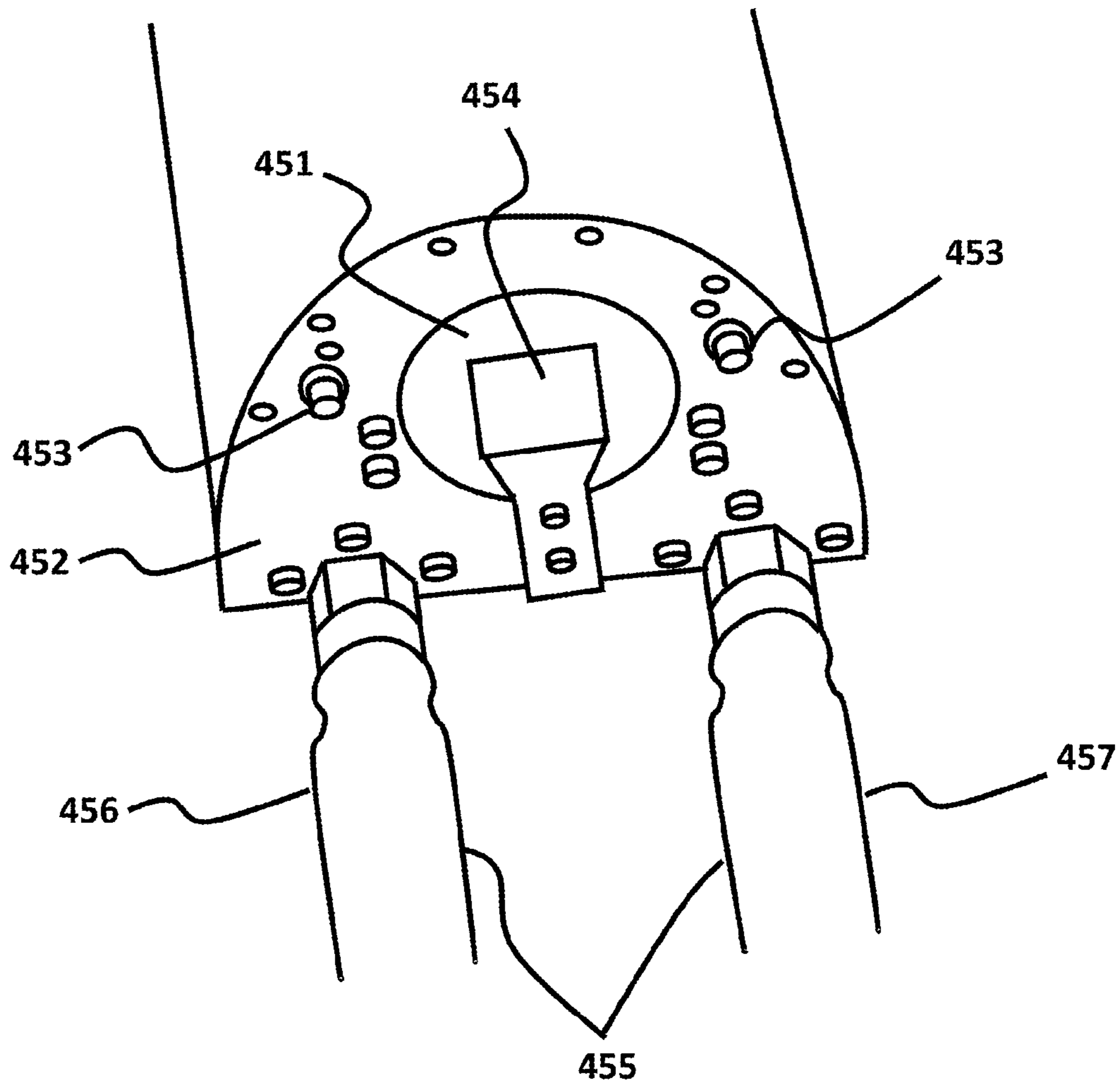

FIG. 4D

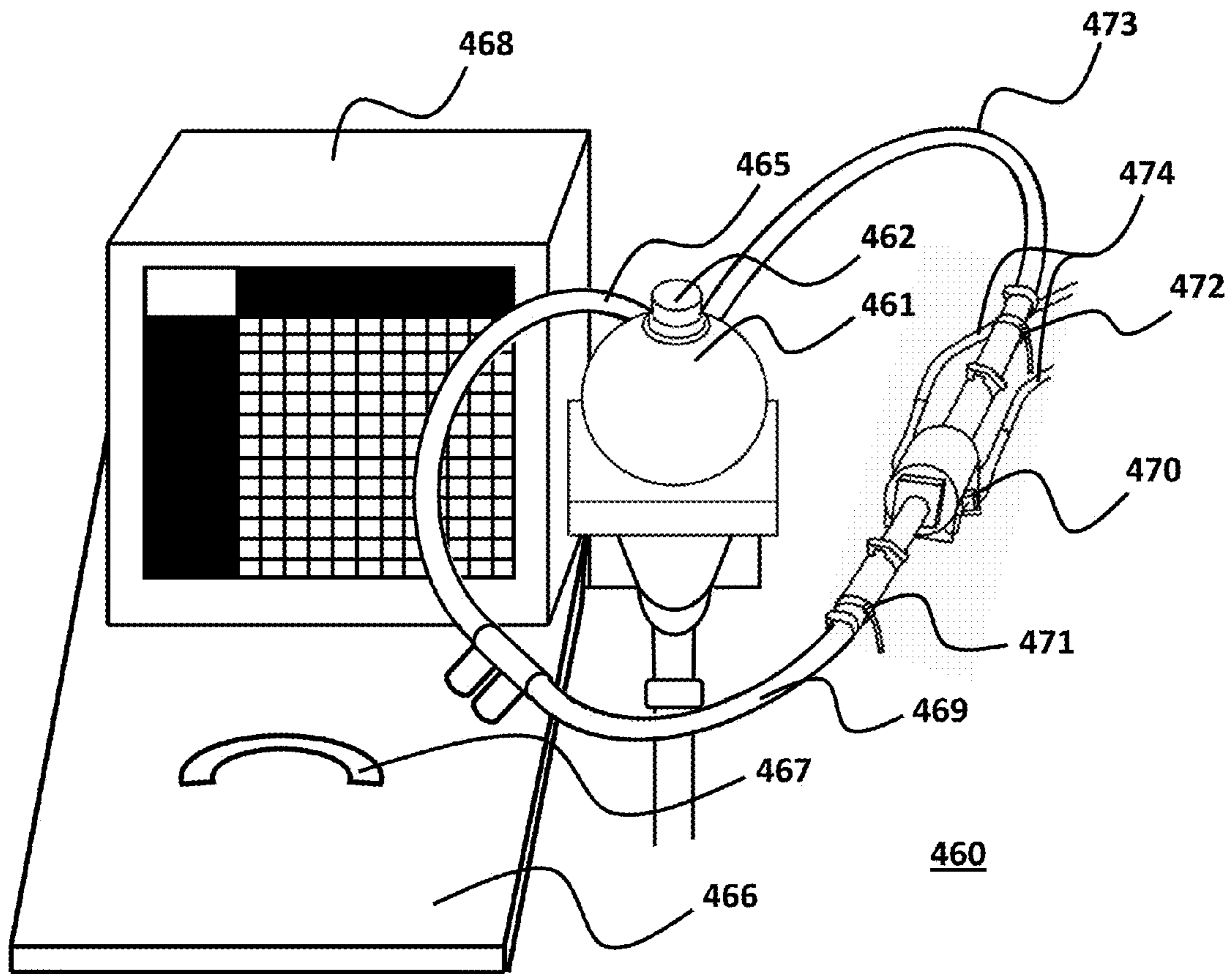

FIG. 4E

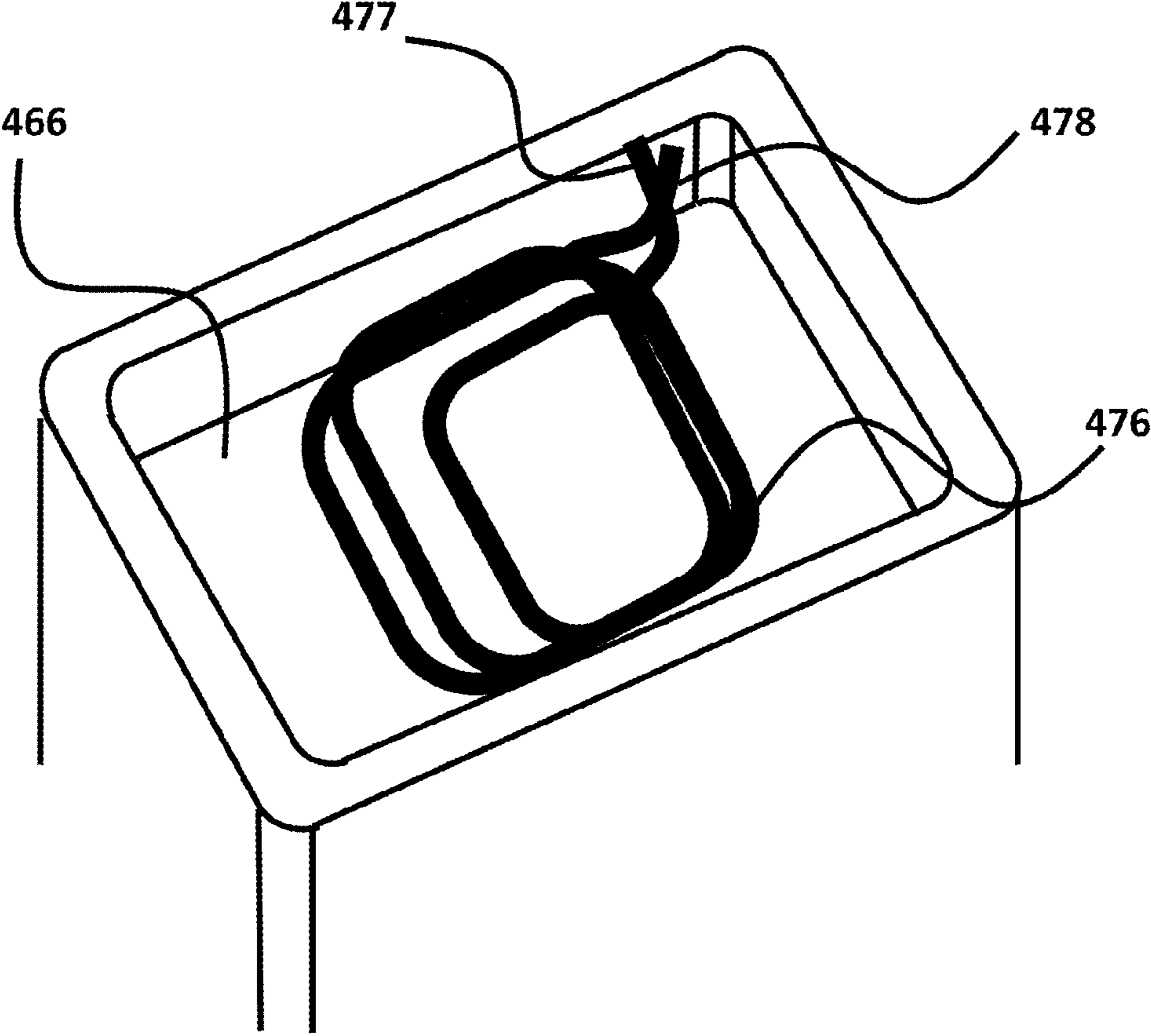

FIG. 4F

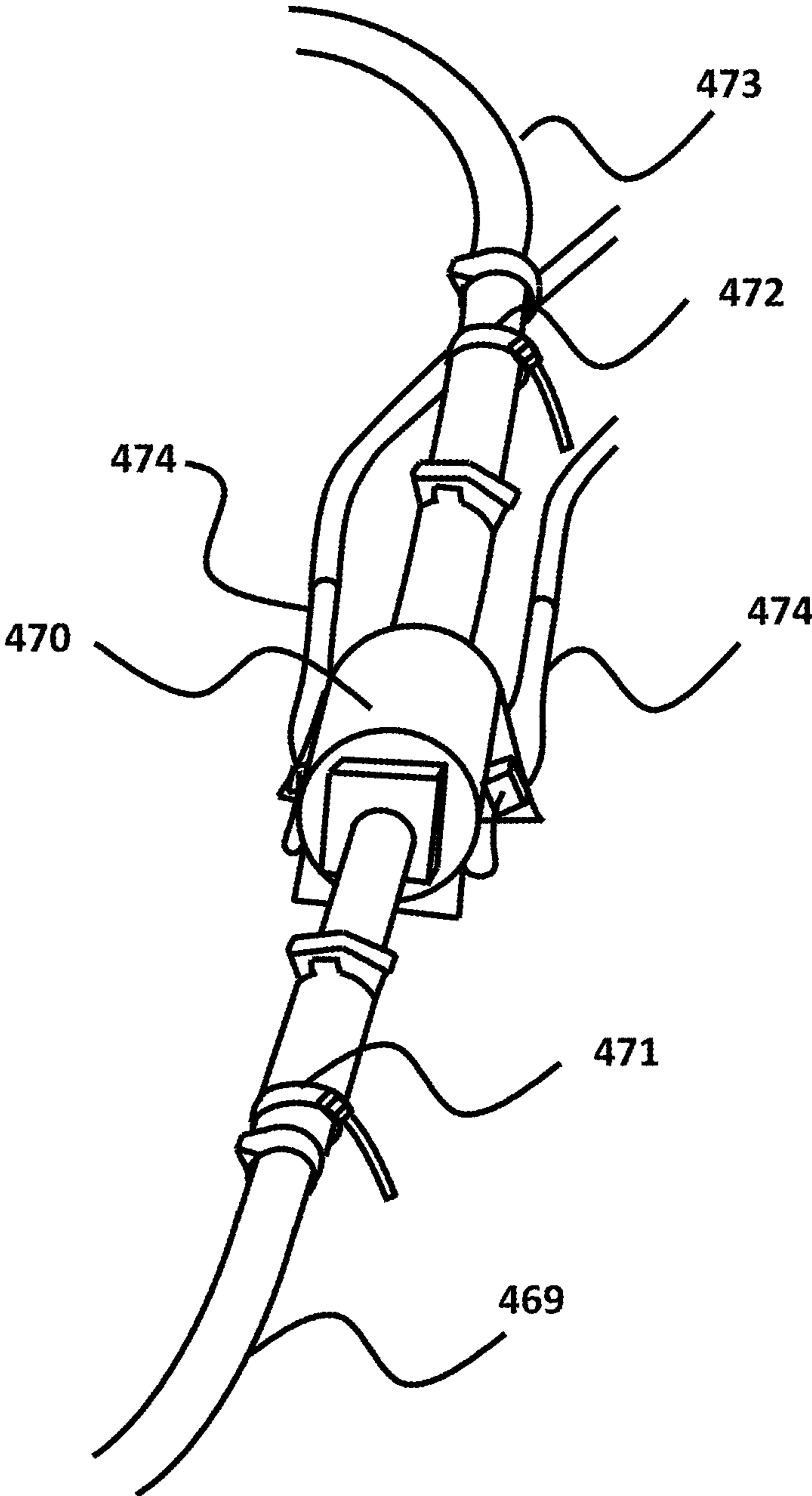

FIG. 4G

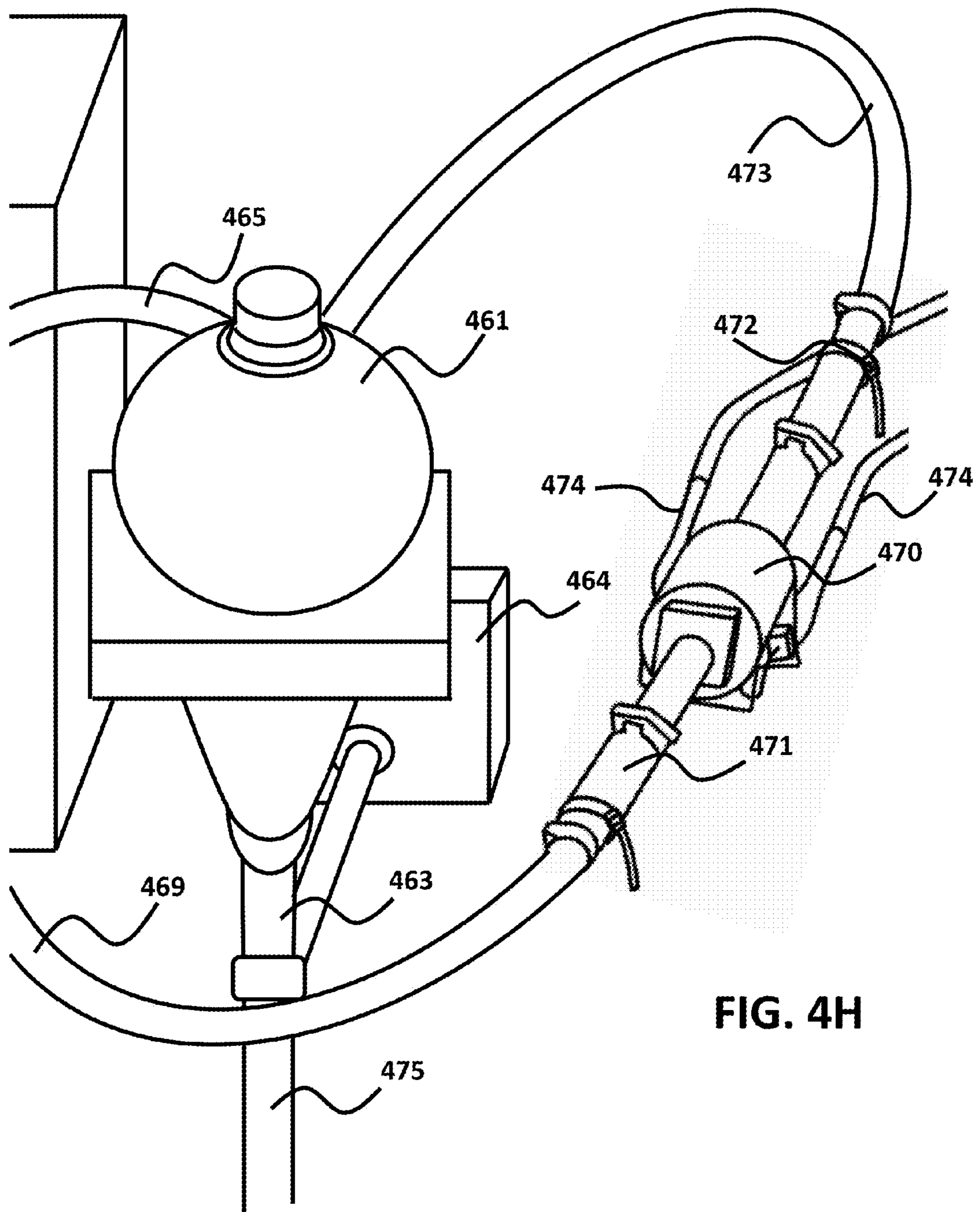

FIG. 4H

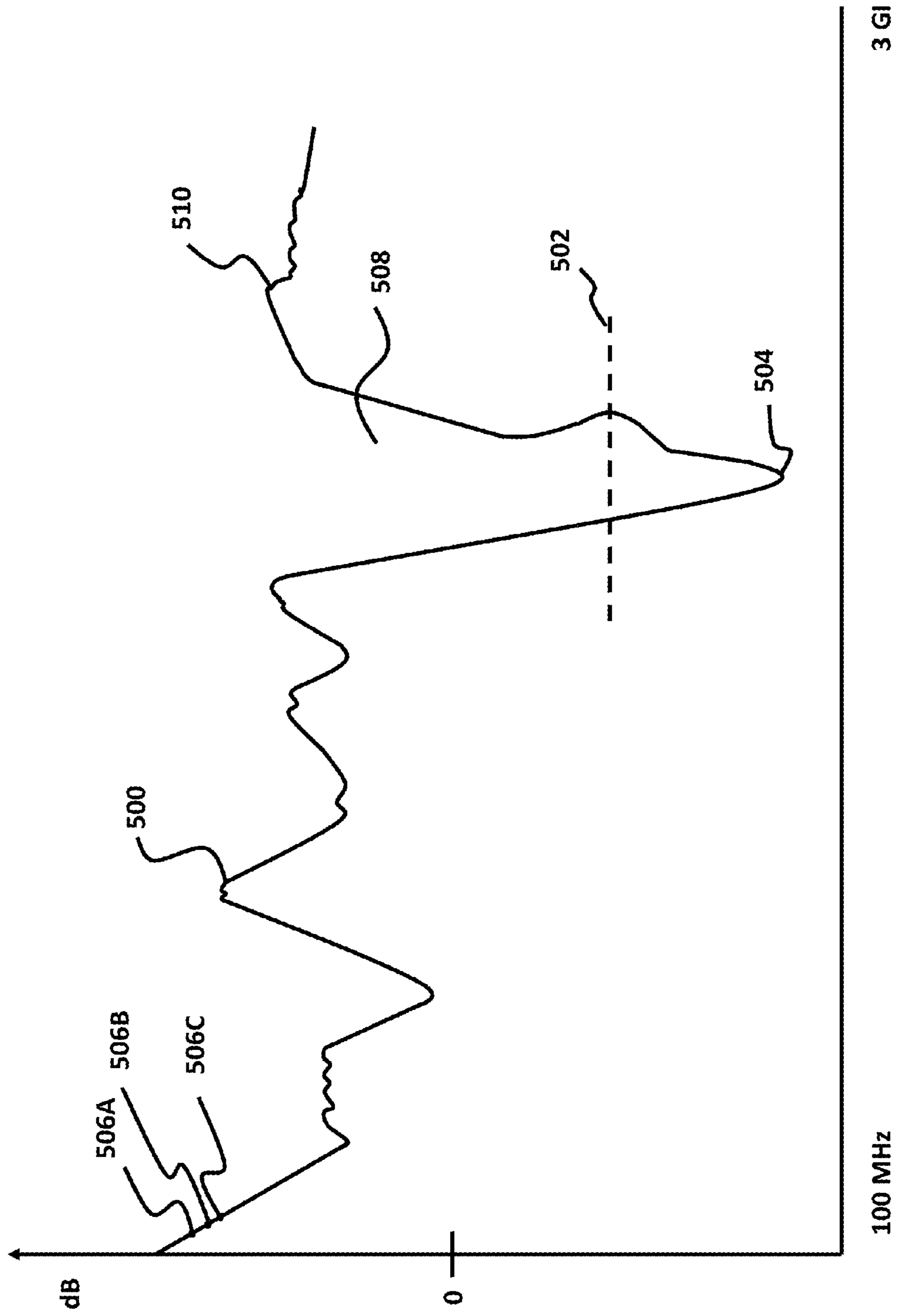

FIG. 5

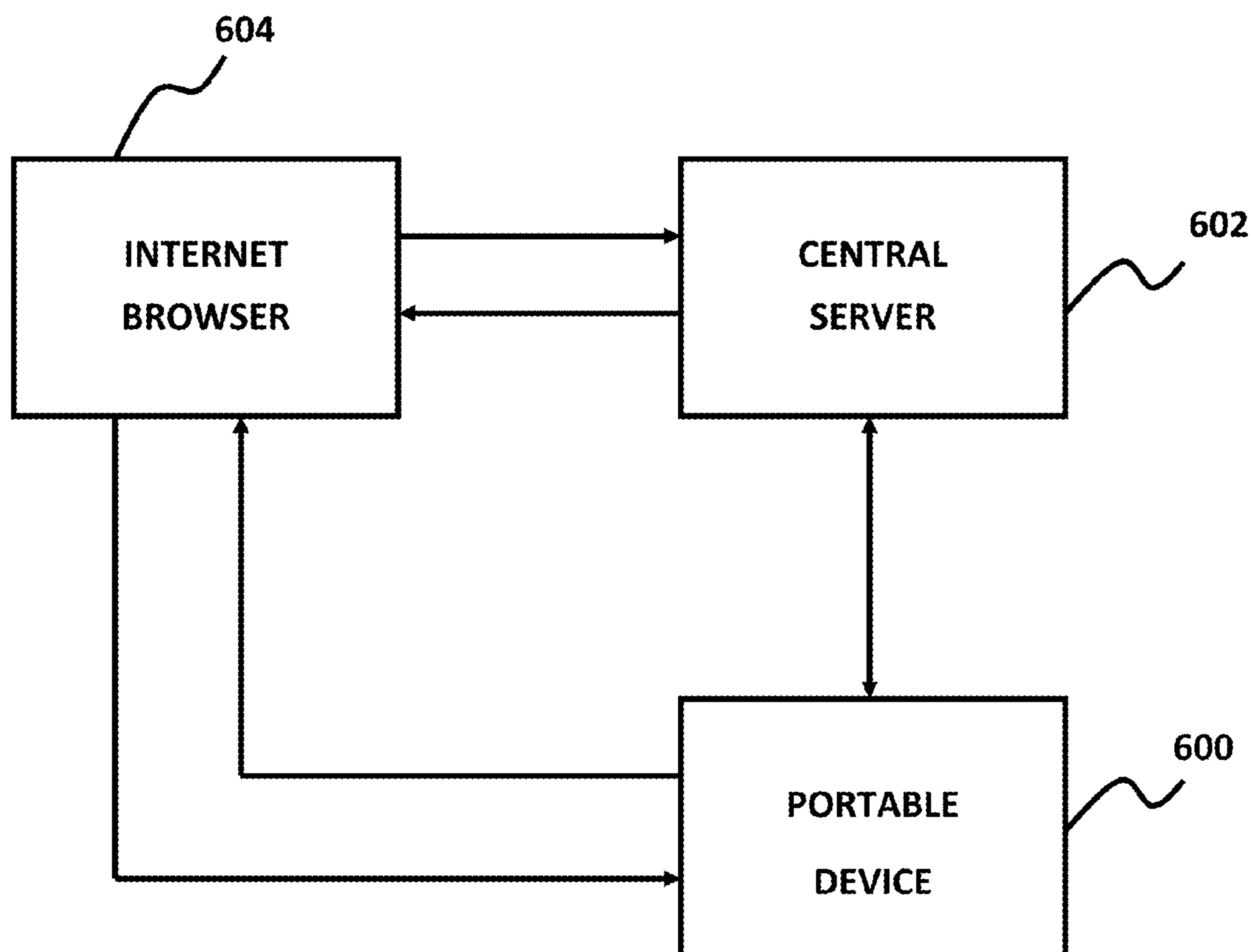

FIG. 6

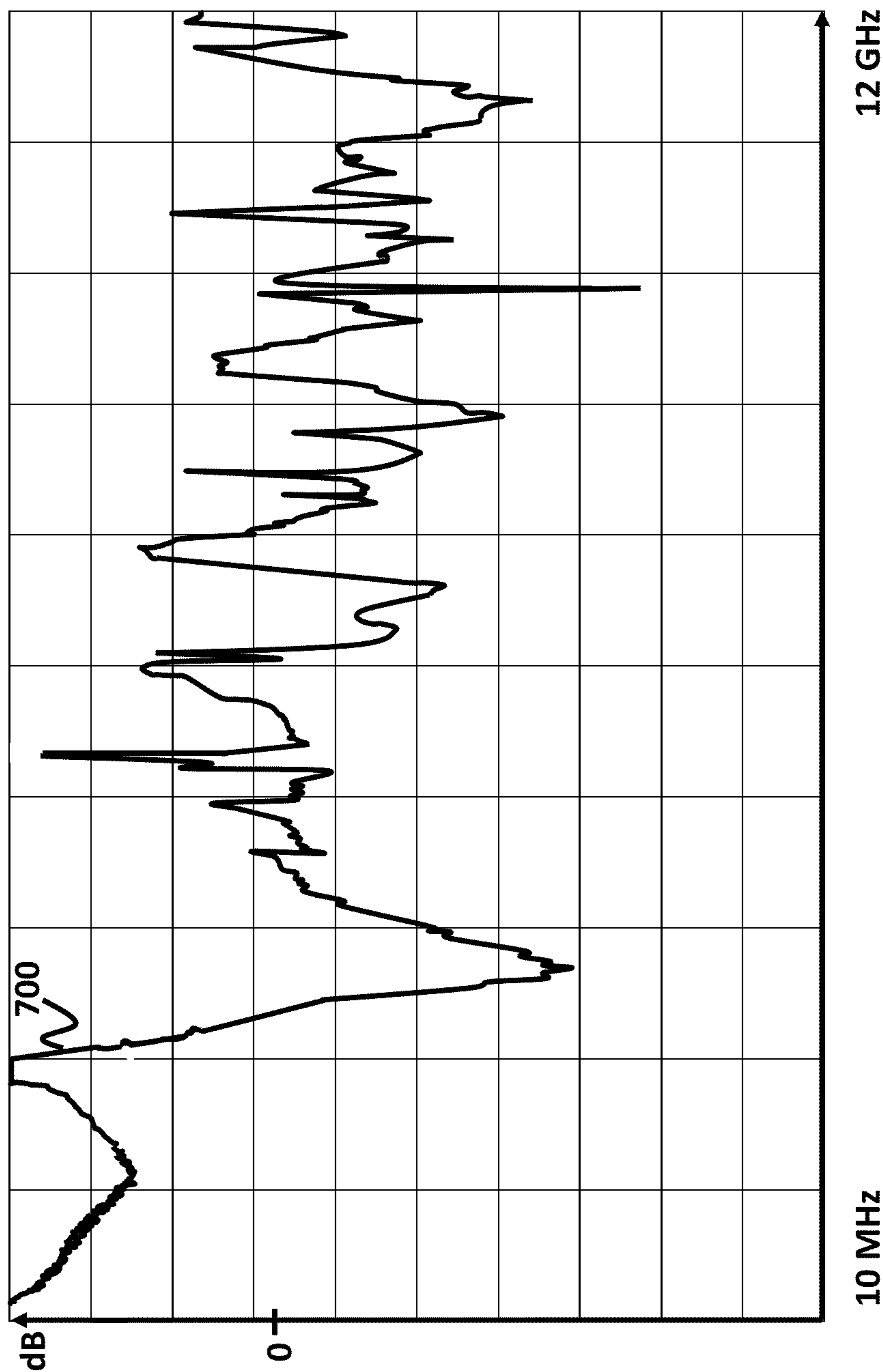

FIG. 7

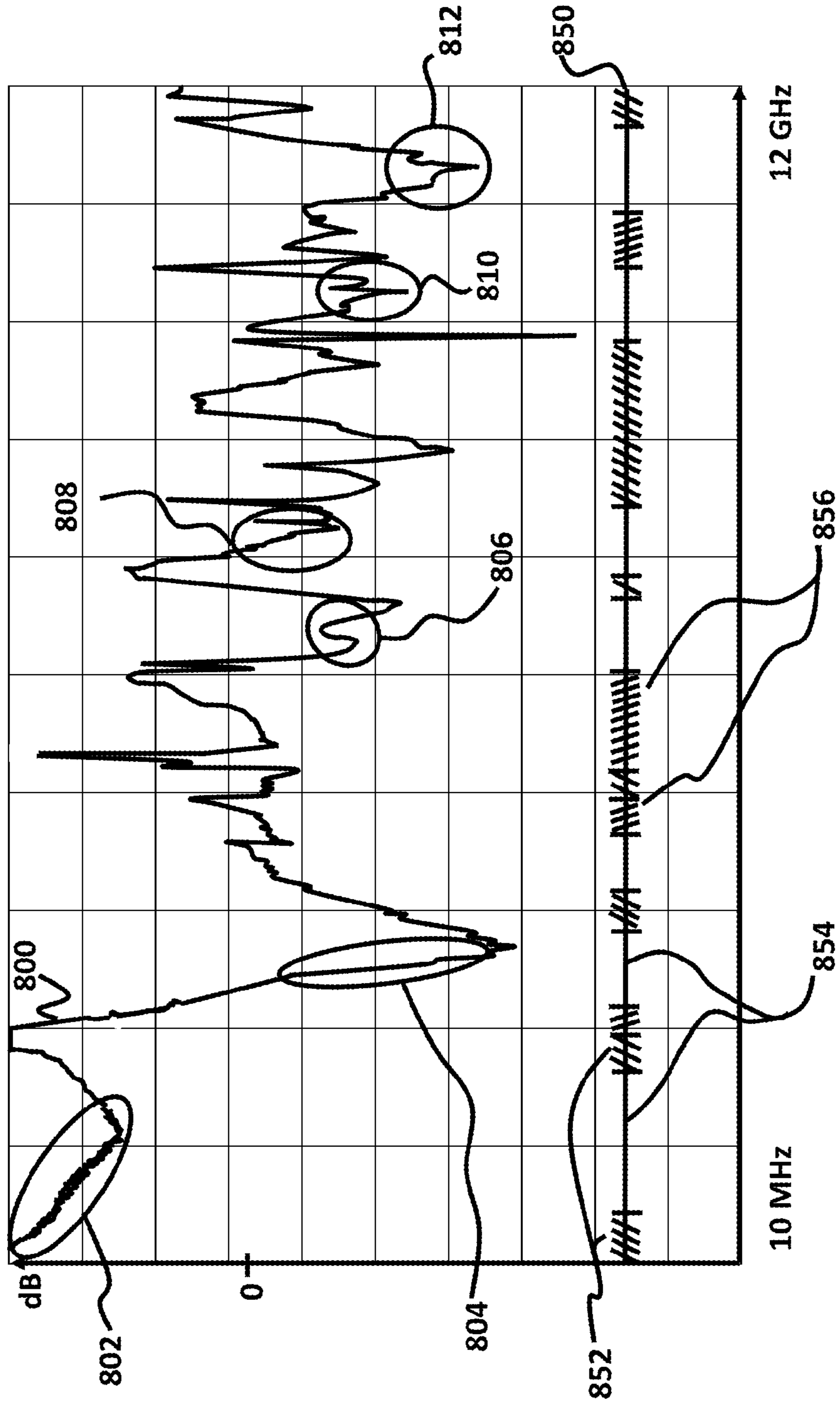

FIG. 8

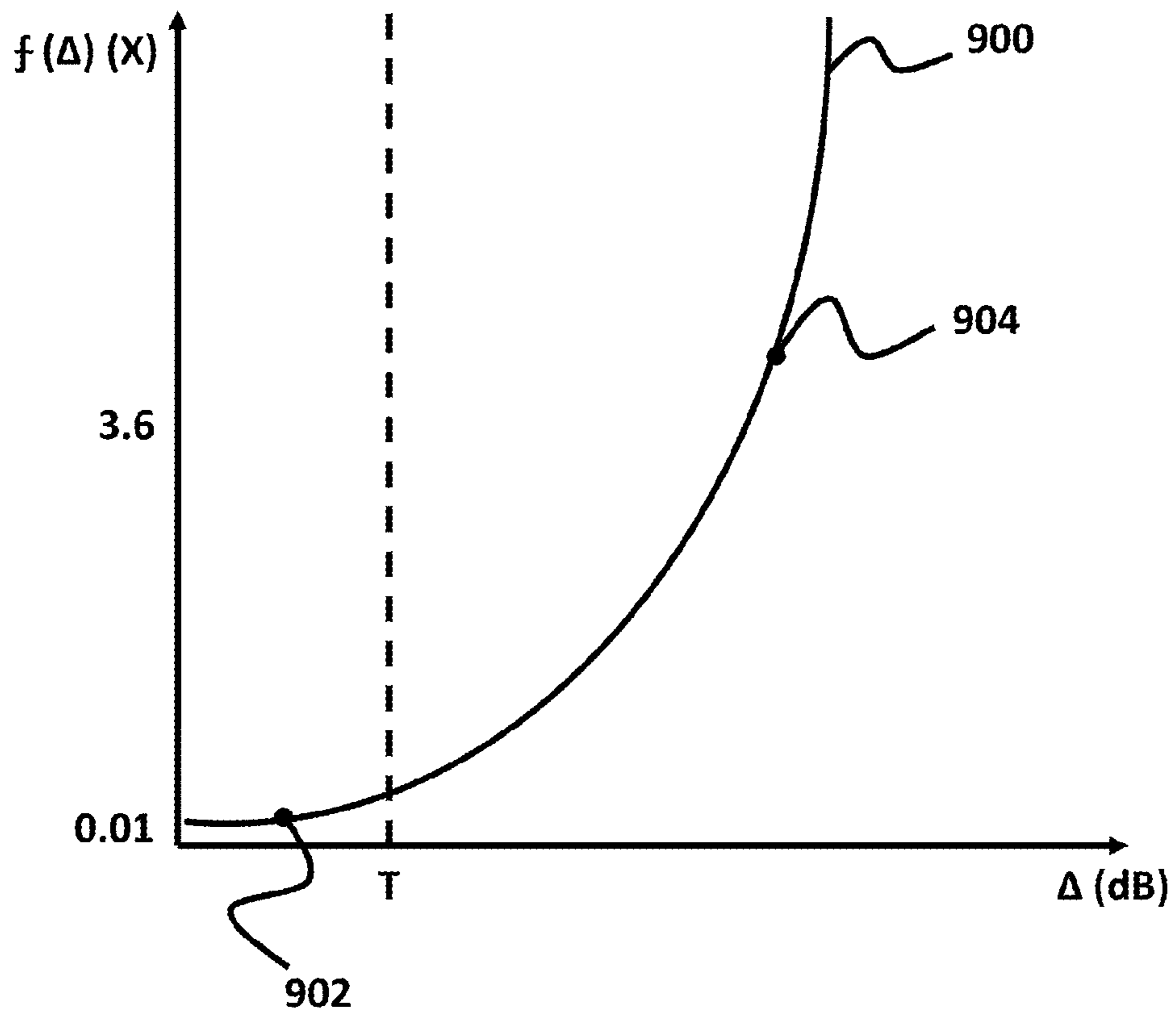

FIG. 9

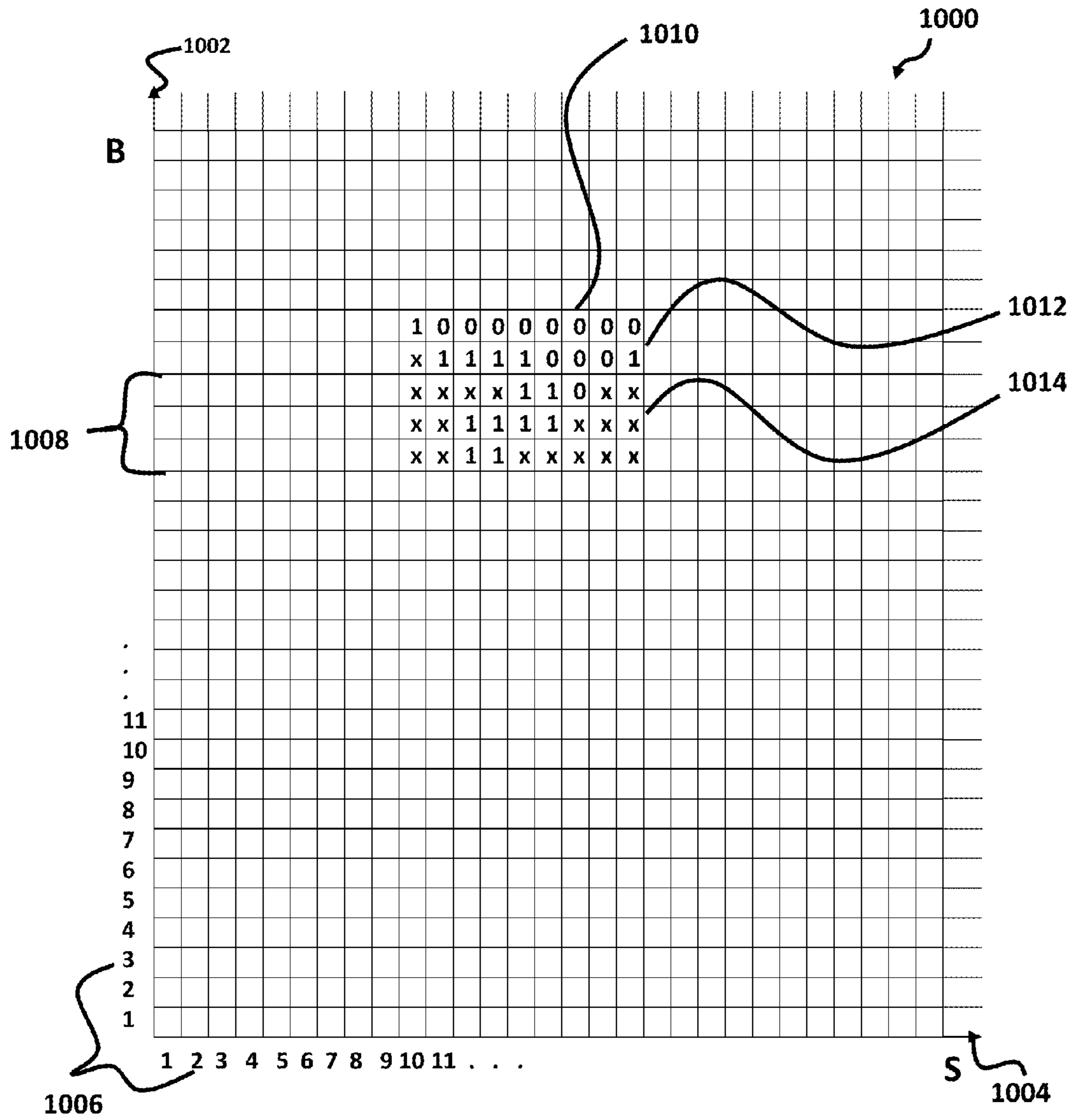

FIG. 10

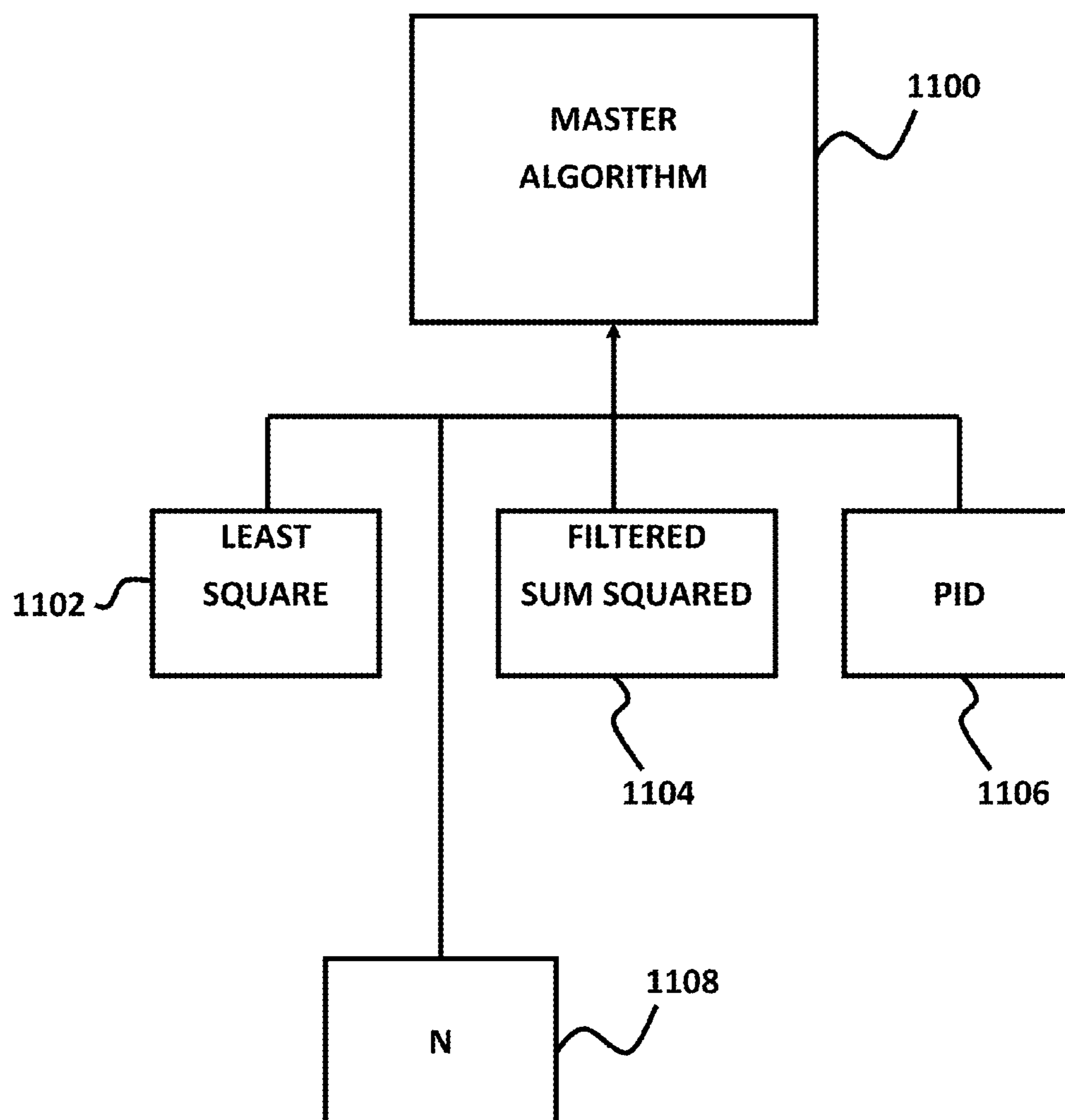

FIG. 11

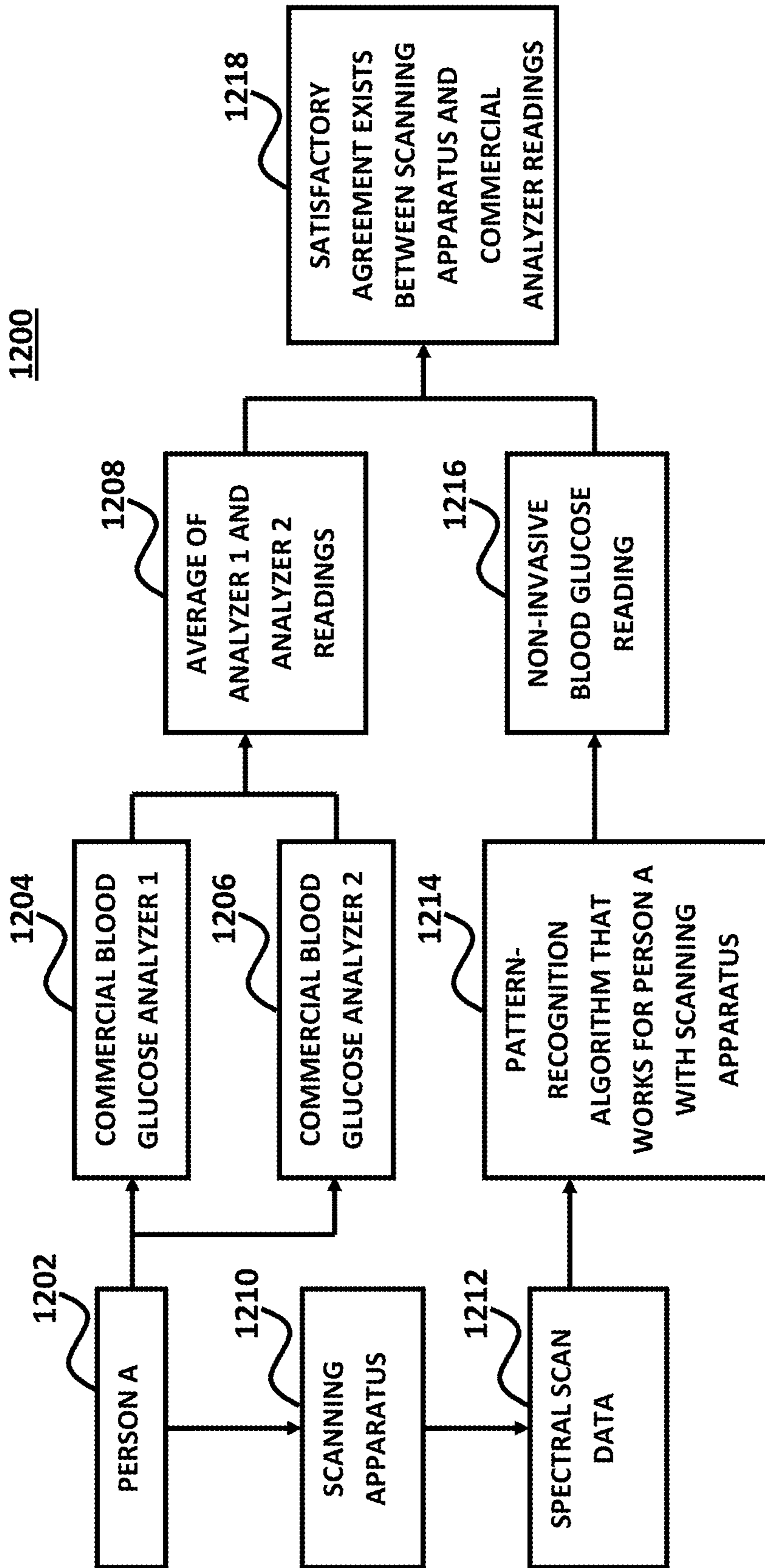
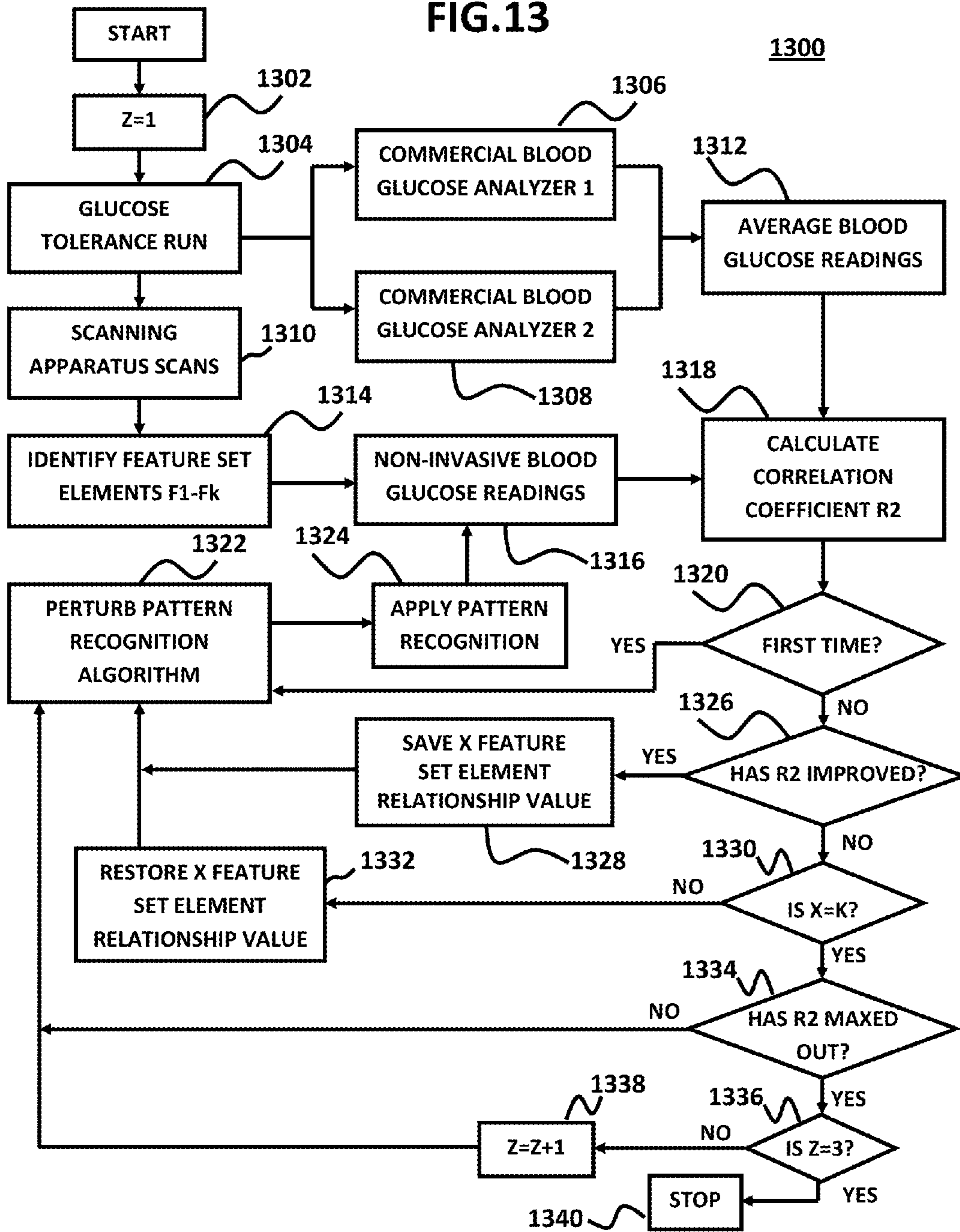

FIG.12

FIG. 13



	G1	G2	G3	G4	G5	G6	G7	G8	G9	G10	G11	G12
R	R1	R1	R1	R1	R1	R1	R1	R1	R1	R1	R1	R1
A	R2	R2	R2	R2	R2	R2	R2	R2	R2	R2	R2	R2
T	R3	R3	R3	R3	R3	R3	R3	R3	R3	R3	R3	R3
I	R4	R4	R4	R4	R4	R4	R4	R4	R4	R4	R4	R4
O	R5	R5	R5	R5	R5	R5	R5	R5	R5	R5	R5	R5
S
	R639	R639	R639	R639	R639	R639	R639	R639	R639	R639	R639	R639

FIG. 14

	R^2	Slope	Intercept
R			
A			
T			
I			
O			
S			

FIG. 15

1600

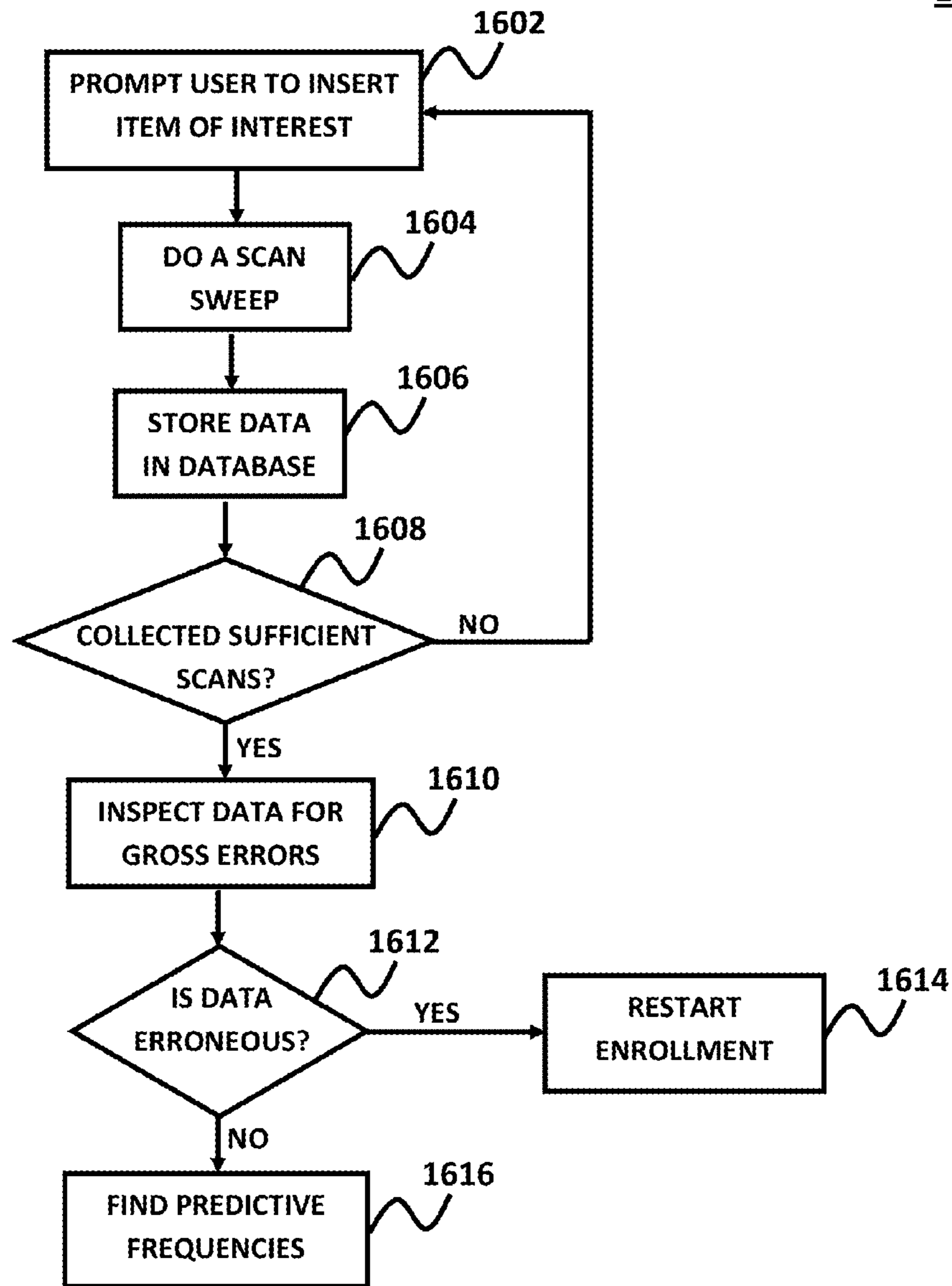

FIG.16

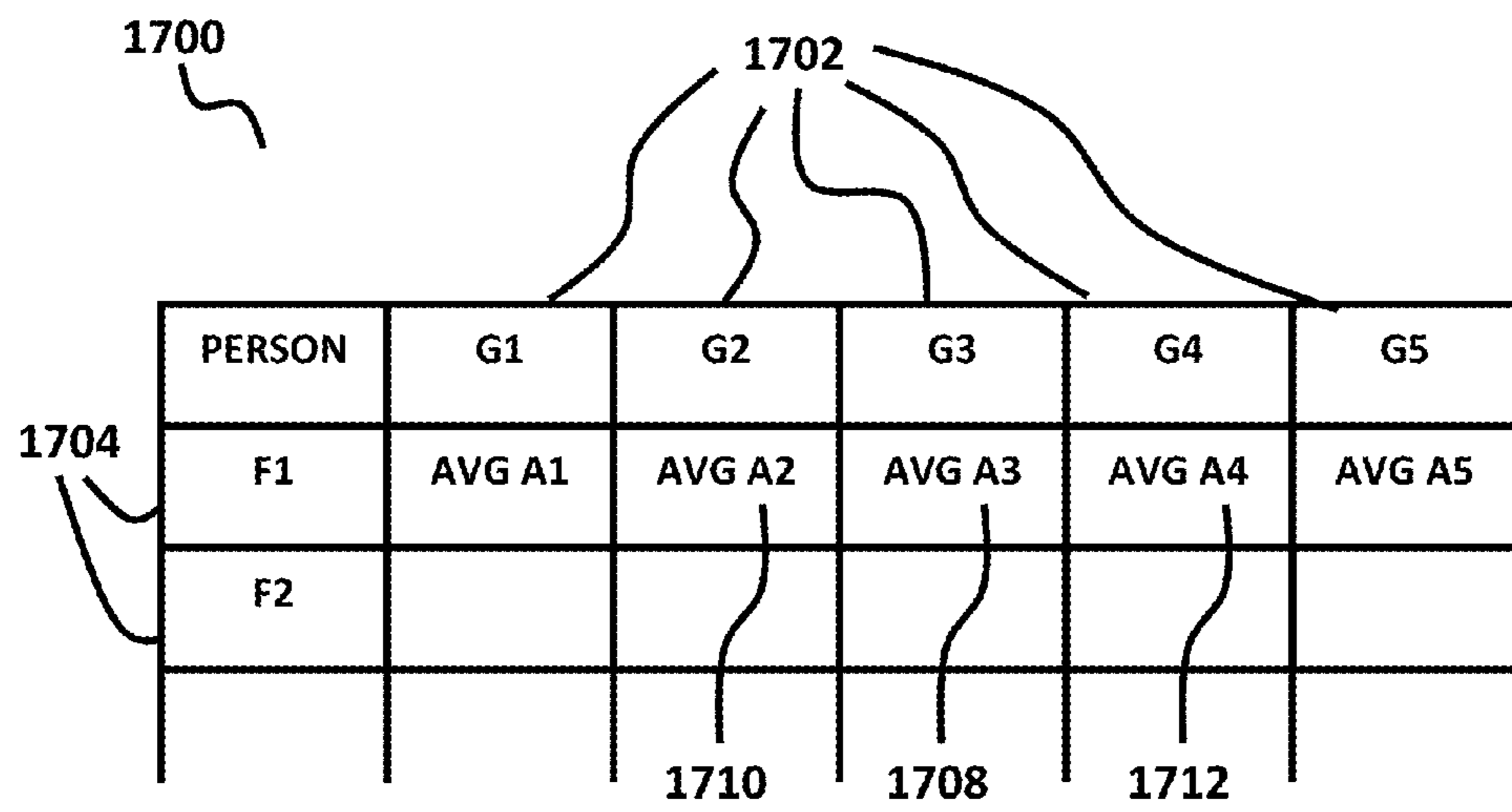

FIG. 17

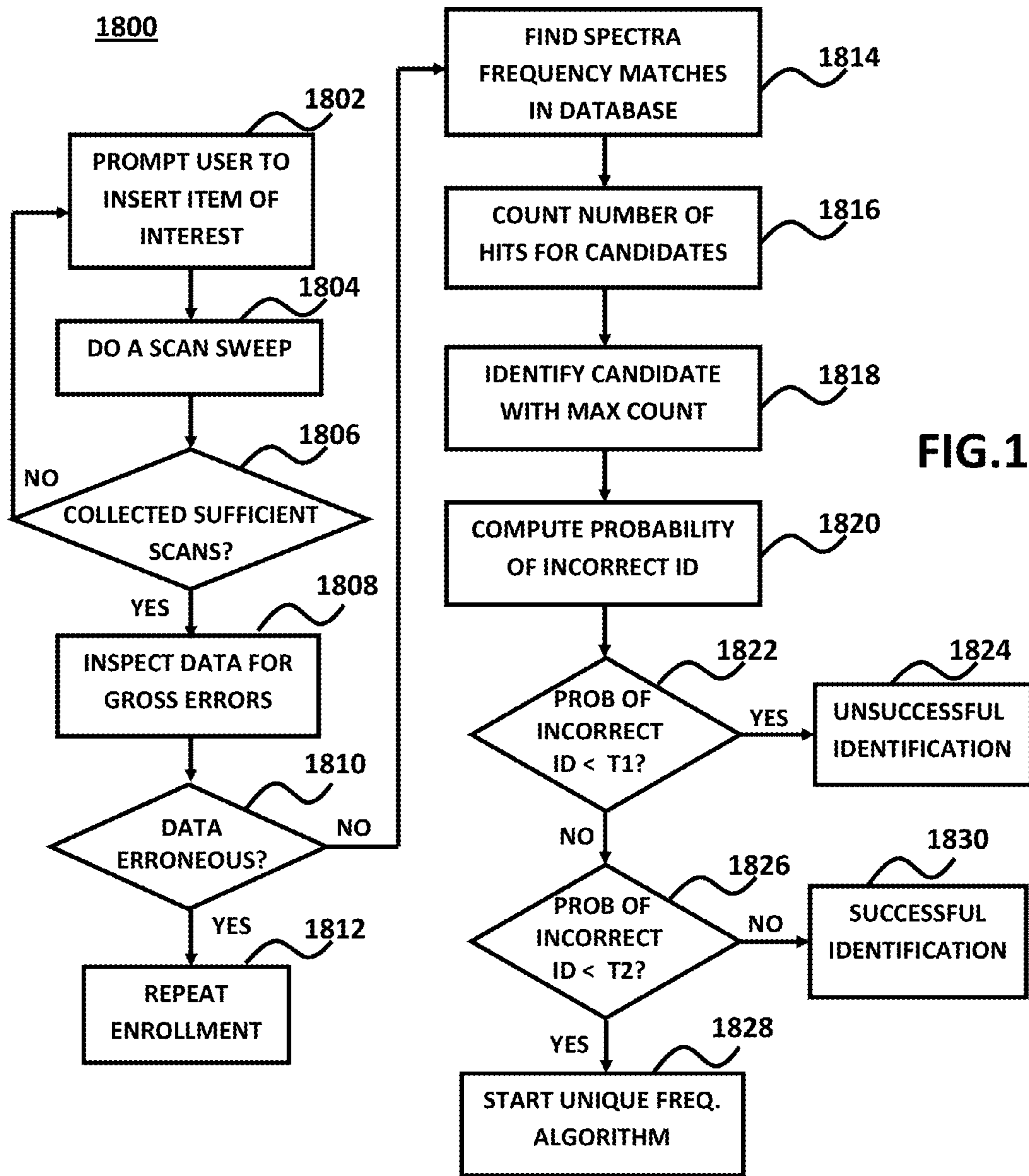

FIG.18

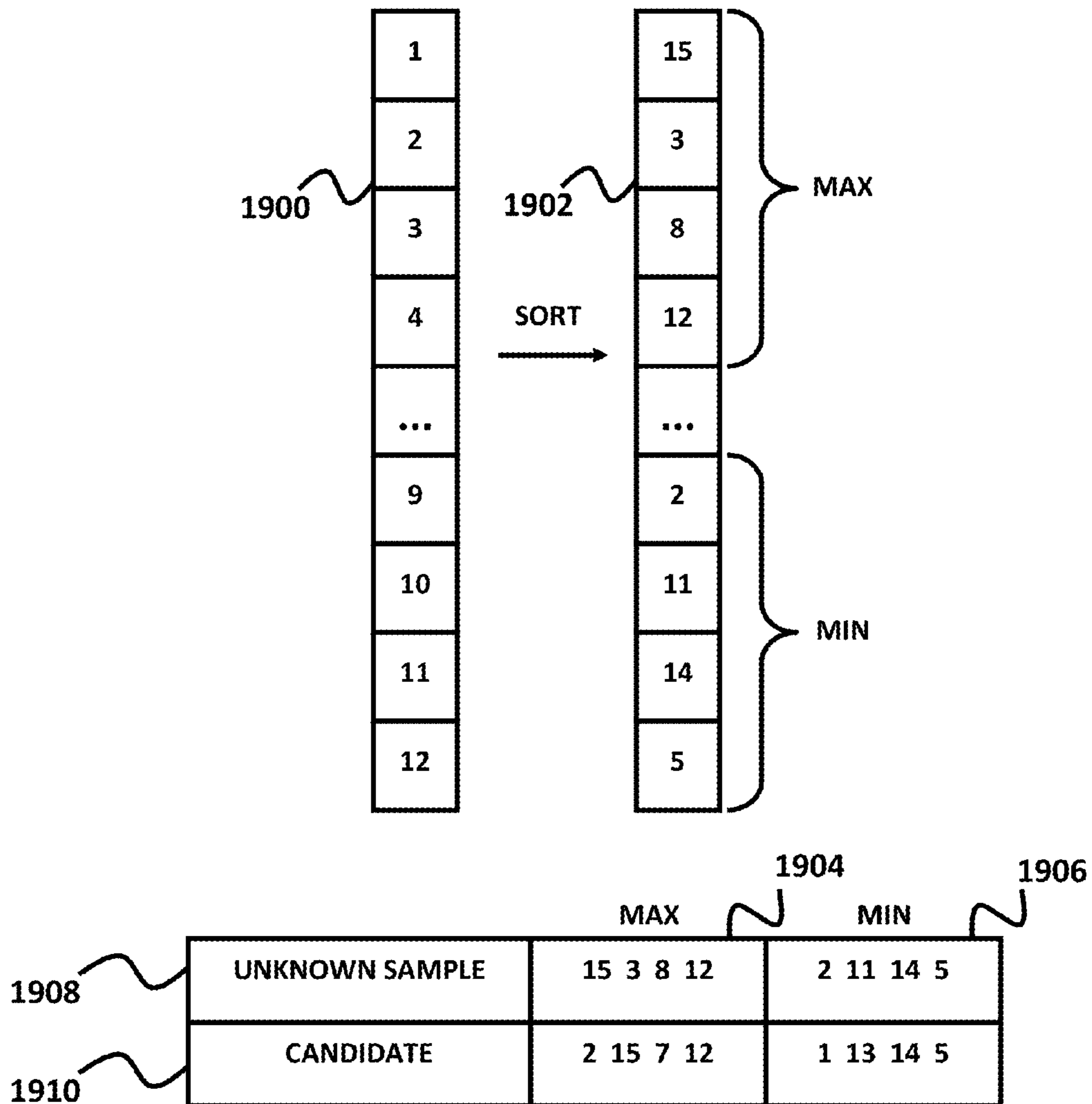

FIG. 19

1

**NON-INVASIVE WEIGHT AND
PERFORMANCE MANAGEMENT****CROSS-REFERENCES TO RELATED
APPLICATIONS**

This application is a continuation-in-part of and claims priority to U.S. patent application Ser. No. 11/821,481, filed 21 Jun. 2007, and is taking priority from provisional patent application Ser. Nos. 61/115,767, filed 18 Nov. 2008; 61/116,417, filed 20 Nov. 2008; 61/116,959, filed 21 Nov. 2008; and 61/117,056, filed 21 Nov. 2008, all of which are incorporated herein by reference.

BRIEF DESCRIPTION OF THE INVENTION

Systems and methods for weight and performance management are disclosed. More particularly, systems and methods of employing non-invasive, real-time, continuous blood glucose, lipid and electrolyte monitoring devices to measure concentration levels in a subject are revealed. The determined levels are subsequently used to manage the subject's caloric intake and utilization multiple times during the course of a day.

**STATEMENTS AS TO THE RIGHTS TO
INVENTIONS MADE UNDER FEDERALLY
SPONSORED RESEARCH OR DEVELOPMENT**

Not applicable.

**REFERENCE TO A "SEQUENCE LISTING," A
TABLE, OR A COMPUTER PROGRAM LISTING
APPENDIX SUBMITTED ON A COMPACT DISK**

Not applicable.

BACKGROUND OF THE INVENTION

Electromagnetic radiation has been used in a wide array of noninvasive diagnostic applications. X-rays have been used for many years to create a two dimensional image of the inside of an object. Computed axial tomography scanners are able to generate three dimensional images from a series of two dimensional x-ray images. Magnetic resonance imaging (also known as nuclear magnetic resonance spectroscopy), such as disclosed in Harms et al., U.S. Pat. No. 5,415,163 A and Rapoport et al., U.S. Pat. No. 4,875,486 A, operate by first applying a magnetic field to a subject so as to align, in a uniform manner, the nuclei of atoms within a portion of the subject to be tested. These aligned nuclei are then briefly exposed to a radio frequency (RF) signal set to a specific frequency, which causes each of the various aligned nuclei at a lower energy state to spin or flip to a higher energy state, known as a resonant frequency. The magnetic field is then removed or altered, causing the nuclei forced to a resonant frequency to become unstable and return to their original lower energy state. This later process is called spin relaxation. The faint energy released from the spin relaxation is then collected as a representation of the nuclei within the sample.

Hence, the spin relaxation energy released by the sample is used to generate an image that is representative of the sample. The RF signal itself is not utilized for detection or imaging purposes—it is only used to excite the nuclei to a higher energy state and is removed before the spin relaxation energy is detected. Further, the magnetic field(s) are only used to

2

align and then release the nuclei in the sample, and are removed or altered before spin relaxation can occur.

While electromagnetic signals transmitted through a specimen have been used to detect or measure the concentration of various chemicals in that specimen, such prior techniques were not highly accurate and results were often difficult to repeat. For example, U.S. Pat. No. 4,679,426 disclosed a non-invasive technique for measuring the concentration of chemicals, such as sodium chloride, in a sample. Periodic electromagnetic waves between 10 MHz and 100 MHz were coupled to a subject's finger and resulting waveforms were found to be indicative, at specific frequencies (i.e., 17.75 MHz for sodium chloride and potassium chloride), of concentration levels of those chemicals in the finger. Likewise, U.S. Pat. No. 4,765,179 used periodic electromagnetic waves between 1 MHz and 1 GHz, that were coupled to a subject's finger, to generate a waveform that provided meaningful analysis of glucose levels in the subject based on the presence of other compounds in the subject's blood at specific frequencies (i.e., 17.75 MHz for sodium chloride and potassium chloride, 11.5 MHz for ethyl alcohol, etc.).

In U.S. Pat. No. 5,508,203 (the "'203 patent"), high frequency electromagnetic radiation was coupled to a specimen through a probe pair to generate a signal of varying amplitude or phase that could be compared to a source signal to determine the presence of a target chemical, such as NaCl, to help determine glucose levels. While this later technique represented an improvement over the prior methods, it was soon realized that electrolytes, e.g., NaCl, KCl, Na₂HPO₄, and KH₂PO₄ of varying concentrations in human blood, can affect the accuracy of glucose measurements using the '203 patent.

To account for the deficiencies in the '203 patent, a new technique was developed in U.S. Pat. No. 5,792,668 (the "'668 patent"), in which two signals were transmitted through the subject at the same time and the magnitude of impedance at the subject was measured to determine a glucose level in the subject. In particular, the two signals had a cross-over frequency of about 2.5 GHz that provided the best measurement of impedance. In blood specimens, it was found that electrolyte concentration effects are effectively "tuned out" by examining impedance at this cross-over frequency. A similar approach was applied in U.S. Pat. No. 7,184,810 (the "'810 patent"), which cites the '668 patent. In the '810 patent, a probe is applied to the subject's skin, through which electric pulses from a pulse generator are fed and partially reflected back to a measuring device, where a time resolved measurement is made. The glucose level is determined from matching the measured voltage to a calibration table.

The next evolutionary step in the development of electromagnetic energy signals to determine the presence and concentration level of chemicals within a subject is represented in U.S. Pat. No. 6,723,048 B2 (the "'048 patent"), which is assigned to the assignees of the present application and which discloses a noninvasive apparatus for analyzing blood glucose and similar characteristics. The '048 patent apparatus utilizes spaced apart transmission and detection nodes placed on either side of and in contact with a sample to be tested. The nodes are always in close proximity to one or more pairs of magnets that create a magnetic field that envelope the nodes and the sample between the nodes. An RF signal having a frequency between 2 GHz and 3 GHz is transmitted from the transmission node through the sample and to the detection node.

The detected signal is then sent to an analyzer that employs pattern recognition techniques to compare the detected signal at a specific frequency (with respect to glucose, the '048

patent specified 2.48 GHz), to previously detected signals at the same frequency to make a determination regarding the characteristic of the sample being tested. For example, if the sample was a finger of a patient that had previously been tested when the patient was known to have different glucose levels (verified through a more traditional form of glucose testing) to create three or more previously detected signal patterns, the presently detected signal would be compared to each of these previously detected signal patterns to determine which pattern it most closely resembled in order to approximate the patient's present blood glucose level.

In addition to testing glucose levels and other blood chemistries, it has been speculated that electromagnetic frequency spectrum technologies could have application to the biometric identification field, but development is still needed in this area. In many fields of activity, it is essential that persons be identified or their claimed identity be authenticated. Examples of such fields include granting physical access or entry into buildings, rooms or other spaces, airport security, credit card purchasers, ATM users, passport verification, electronic access to information or communication systems, etc.

A number of noninvasive detection technologies have been developed to address these needs, such as fingerprint scans, iris and retina scans, and voice recognition. These technologies operate on the principal that individuals possess unique and unchanging physical characteristics that can be measured and compared with stored data. The basic requirements for acceptable biometric technology are that it must allow for practical widespread use, be accurate and reliable, be difficult or impossible to circumvent, be quick, easy and convenient, present no or little privacy violation concerns, be low cost to produce, and be consumer friendly. Current biometric identification and authentication technologies do not meet all of these basic requirements.

Iris and retina scanning technologies can be highly accurate, but the equipment used in scanning is expensive and requires substantial space. Further, humans are highly uncomfortable with the idea of having their eyes scanned with a laser or infrared light or having their picture taken and stored by a machine (and then used by who knows who). Also, iris and retina scanners have been spoofed with a number of techniques that have required the technologies to be modified in various ways, making the technology more expensive, less convenient, and less consumer friendly.

Electronic or optical fingerprint scanning systems are inexpensive, but are not very accurate, are easily damaged, and can be easily spoofed. Variations in skin, ethnic races with very light fingerprint patterns, people with unusually dry skin, elderly people, people with rough hands, water webbing, abrasions and cuts have all been known to create difficulties for fingerprint systems. Furthermore, many people consider fingerprinting to be an invasion of their privacy because of the heavy use of fingerprinting for law enforcement purposes. Additionally, many fingerprint scanning devices have been easily spoofed with objects as common as gummy candy.

Voice recognition systems tend to be the least accurate of the other biometric identification and authentication technologies. Voices can be readily recorded or mimicked, and allergies, colds and other respiratory issues can readily produce false negatives. Hand geometry and face recognition systems suffer from similar issues. They also tend to require a large amount of space and face recognition systems can be expensive. As with fingerprints, changes in a subject's skin, such as a suntan, a burn or a skin condition, or other changes to a subject's physical appearance can present problems for the system.

Obesity is a major health problem in many countries and is associated with an increased risk for heart disease, certain cancers and development of Type II diabetes. Obesity is now so common within the world's population that it is beginning to replace under-nutrition and infectious diseases as the most significant contributor to ill health (Kopelman (2000) *Nature* 404: 635-643, which is incorporated herein by reference in its entirety). According to the Centers for Disease Control's (CDC's) National Center for Health Statistics, 54% of adult Americans and between 11% and 14% of children were overweight in 1997, as determined using the Body Mass Index (BMI) scale, which defines classes of non-obesity and obesity. According to the BMI scale, obesity is generally defined by a body-mass index (weight divided by square of the height) of $30 \text{ kg}\cdot\text{m}^{-2}$ or greater.

Behavioral interventions play a central role in treatment programs designed to promote lifestyle changes leading to weight management and improved physical fitness. Behavioral studies have shown that the keeping of detailed records, or self-monitoring, is considered one of the most essential features of behavior therapy (Baker & Kirschenbaum, (1993) *Behavior Therapy* 24: 377-394). Some of the earliest research on the behavioral effects of self-monitoring revealed that a subject's awareness of data collection during a study often caused a reactive process that influenced the behavior being observed (Gottman & McFall, (1972) *Journal of Consulting and Clinical Psychology* 39: 273-281). Additionally, these studies have suggested that the accuracy of the information obtained was not as important as self-focusing attention on the behavior (Baker & Kirschenbaum (1993)). Therefore, when it comes to weight management and physical performance enhancement, consistent self-monitoring appears to contribute to the desired outcomes more so than accurate self-monitoring.

Monitoring food intake plays an important role in any weight management program. Self-monitoring of dietary intake is consistently associated with adherence to dietary measures (Schnoll & Zimmerman, (2001) *Journal of the American Dietetic Association* 101: 1006-1011). The more consistently subjects self-monitored, the more weight they lost. This positive effect is seen throughout the literature—consistent self-monitoring of food intake is associated with a decrease in food intake and a subsequent weight loss.

Self-monitoring of physical activity, such as through the use of a diary, can be as important to one's health and physical performance as self-monitoring of food intake. These diaries typically include entries citing the duration of the exercise as well as the intensity of the activity. Furthermore, specific information may be tracked and recorded such as: the weather at the time of the activity, pain or discomfort encountered during the activity, or the number of sets or repetitions performed.

The quantity of blood sugar in a subject's body at any given point is representative of the calories they have consumed as well as utilized as a result of exercise or simply living. Consequently, a subject's blood sugar level correlates well to their weight or performance management. For example, if the subject's blood sugar levels are higher than normalized levels, they may be in a position to gain weight; if their blood sugar levels are lower than normalized levels, they may be in a position to lose weight. While this correlation is well known and incorporated into a number of weight management plans, prior art blood sugar testing devices have not made it practical to test a subject's blood sugar levels multiple times a day to help manage their caloric intake and utilization. An embodiment changes this situation, however, by enabling a user to carefully and painlessly test and manage their caloric intake

5

and utilization many times during the course of a day, thereby enabling use by anyone desiring to control their weight, including athletes, dieters, etc.

Likewise, an athlete's performance could be optimized through use of such a device by carefully monitoring blood sugar levels to make sure the athlete had the optimum amount of fuel for energy in their body at a needed time.

By coupling the blood scanning features of an embodiment to a computer equipped with additional weight management software, a user could track their weight gain or loss over a period of time, but without being relegated to making rough guesses about calories consumed, through food and drink, and utilized, through normal body functions and exercises performed. Performance management software could play a similar cooperative role. Alternatively, an embodiment could be coupled with a calorie counting type of diet, so as to prevent the user from straying from reality (i.e., "that donut was only 50 calories," or "I only had a half portion."). Certain safety features could also be incorporated if a user was consuming too few calories over a period of time or exercising too much, such as by disabling the scanning device or sending a message to a central office so as to enable a person to check on the user.

While it is well known that blood glucose levels can be used to monitor caloric intake and utilization, no presently available glucose monitoring technology can be acceptably used for this purpose. To accurately monitor caloric levels, a subject would need to check their glucose level many times during the course of a day, such as when they first wake-up, eat something, exercise or travel to work, after they have a snack or are active for a period of time, before and after lunch, mid-day, sometime between leaving work and having dinner, perhaps before dinner and after dinner, before going to bed, etc. Consequently, a subject might realistically check their caloric level as many as 15 or 20 times during the course of each day. Existing continuous glucose monitoring devices cannot practically be used this many times each day and would be rejected by subjects for such purposes.

Although devices used to continuously self-monitor blood sugar levels have been available to the public for a few years, current continuous glucose monitors (CGMs) have a number of shortcomings and are impractical for weight and performance management applications. For example, data is stored and downloaded by a healthcare provider. Therefore, no glucose readout is immediately available to the patient, so on-the-spot corrections cannot be made. Also, current continuous, invasive blood glucose monitoring systems may use a needle sensor system, a micropore system, or a microdialysis system. The needle sensor system involves placing a needle under the skin, which sends data through a wire running through the skin to a monitor worn by the patient. To verify their accuracy, these devices require frequent calibration via finger stick tests.

Piercing the body, particularly the fingertips, to draw blood is painful. Lancing the fingertips several times during the course of a day can render the tips so sensitive that it restricts ordinary activities. In addition, studies investigating the long term damage caused by continual body lancing reveal a clear relationship between lancing frequency and skin changes, predominately thickening of the skin in the repeatedly lanced area (Fruhstorfer (2006) *Practical Diabetes International* 23: 207-209).

While for diabetics a finger stick to monitor blood sugar levels may seem like a minor nuisance compared to the complications that uncontrolled diabetes can cause, it is often enough to deter those subjects from testing their blood sugar levels as often as necessary. This being the case, subjects who

6

are not combating a potentially debilitating disease, but who merely wish to monitor blood glucose levels to maintain a healthy weight or to maximize physical performance, would certainly be dissuaded from regularly monitoring their blood glucose levels using current technologies.

Consequently, there is a desire for a less invasive method of glucose measurement and monitoring for a variety of uses. Methods exist or are being developed for a minimally invasive glucose monitoring, which use body fluids other than blood (e.g., sweat, tears, or saliva) or subcutaneous fluid. Sweat and saliva are relatively easy to obtain, but their glucose concentration appears to lag in time significantly behind that of blood glucose. For that reason, tears, saliva and sweat have failed as viable matrices for use as surrogates for blood in monitoring glucose levels.

Other minimally invasive CGMs measure the glucose level of interstitial fluid utilizing a small catheter inserted between layers of skin. However, as with the blood samples of the minimally invasive blood glucose monitoring devices described above, glucose levels in interstitial fluid lag temporarily behind blood glucose values. Patients therefore require traditional finger stick measurements for calibration (typically twice a day) and are often advised to use finger stick measurements to confirm glucose levels. These systems are problematic in that temperature and perspiration can affect fluids in interstitial space and can subsequently influence the measurements.

Several companies have developed blood test products that are less invasive and require smaller blood volumes. With these products, blood can be drawn from other areas of the body such as the arms and legs. However, blood drawn from an arm or a leg using these products appears to more slowly reflect the changes in blood sugar than blood samples drawn from the fingertips. And although drawing blood from these alternate sites is less painful than drawing the blood from the nerve-rich fingertips, these products still require piercing the skin.

Current CGM technologies fall short of meeting the needs of diabetics whose lives would greatly benefit from continuous glucose monitoring. And while these technologies fail to meet the needs of those subjects most in need, they are even less adequate for subjects who simply wish to monitor their glucose levels so as either 1) to maintain a healthy weight, thereby reducing their risk of other physical complications, or 2) to maximize their physical performance.

For these subjects, permanently attached needles, catheters or monitors that restrict physical movement are unacceptable. Lag times between glucose values in alternate body fluids or in blood samples drawn from other parts of the body versus immediate glucose values are impractical. Measurements affected by temperature or perspiration are useless. Alternatively, immediate glucose readouts available to the patient so on-the-spot corrections can be made are essential.

Clearly, there is a bona fide need for a non-invasive, real-time, continuous blood glucose, lipid and electrolyte monitoring method to assist subjects in managing their weight as well as for performance management.

BRIEF DESCRIPTION OF THE SEVERAL VIEWS OF THE DRAWING

FIG. 1 is a block diagram illustrating the transmission, reception and analysis systems of an embodiment;

FIG. 2 is a partially cut-away, perspective view with hidden lines of the sample scanning apparatus of an embodiment;

FIG. 3 is a cross-sectional view of either a transmission node or a receiver node of an embodiment;

FIG. 4A is a partially exploded, perspective view of an embodiment including one pair of nodes and two pairs of magnets;

FIG. 4B is a partially exploded, perspective view of an embodiment including two pairs of nodes and two pairs of magnets;

FIG. 4C is a perspective view of an embodiment of a scanning apparatus;

FIG. 4D is a perspective view of the rear of the scanning apparatus of FIG. 4C;

FIG. 4E is a perspective view of an embodiment of a flow through sensor;

FIG. 4F is a perspective view of an embodiment of the temperature control unit of the flow through sensor of FIG. 4E;

FIG. 4G is a more detailed perspective view of an embodiment of a scanning apparatus for use in the flow through sensor of FIG. 4E;

FIG. 4H is a more detailed perspective view of the flow through sensor of FIG. 4E;

FIG. 5 is an illustration of a composite spectrogram display for glucose scanning in accordance with an embodiment;

FIG. 6 is a block diagram illustrating a remote detection and analysis configuration in accordance with an embodiment;

FIG. 7 is an illustration of a real-time composite spectrogram for biometric identification in accordance with an embodiment;

FIG. 8 is an illustration of a stored spectrogram for comparison to the real-time spectrogram of FIG. 7, and further illustrating the areas of difference and the regions of relevance between the two spectrograms;

FIG. 9 is an illustration of a filtering analysis in accordance with an embodiment;

FIG. 10 is an illustration of a personal identity determinator (PID) in accordance with an embodiment;

FIG. 11 is a block diagram illustrating the master biometric identification algorithm and its sub-element algorithms;

FIG. 12 is a flow chart representing an operating method for fine-tuning pattern recognition algorithms;

FIG. 13 shows a flow chart representing a method for fine tuning pattern recognition algorithms for instances when a prior subject uses a new sensor;

FIG. 14 is a representation of a ratio matrix of clusters for use in a quantification embodiment;

FIG. 15 is a representation of a preliminary registration table for use in the quantification embodiment of FIG. 14;

FIG. 16 is a flow chart representing the enrollment process of the True-Call algorithm embodiment;

FIG. 17 is a representation of a table used for an embodiment of the True-Call algorithm;

FIG. 18 is a flow chart representing the identification process of the True Call algorithm embodiment; and

FIG. 19 is a representation of an embodiment of a biometric identification application.

DETAILED DESCRIPTION OF THE INVENTION

A real-time, non-invasive continuous blood glucose, lipid and electrolyte monitoring system and methods for weight management and performance enhancement in a subject are disclosed.

Carbohydrates (e.g., starches) are the human body's key source of energy. The breakdown of carbohydrates in the body yields a variety of sugars, most of which is in the form of the monosaccharide glucose. Living cells in the blood use glucose as a source of energy and as a metabolic intermediate,

i.e., in the production of proteins and in lipid metabolism. As a result, glucose is also commonly known as blood sugar.

In an embodiment, a method for evaluating compliance with a weight management program in a subject, wherein monitoring of glucose amount or concentration in the subject is accomplished by monitoring glucose in the blood of the subject using the scanning apparatuses technology developed by Pindi Products, Inc., the assignee of the present invention. In this method a reference range of glucose amounts or concentrations is determined that correspond to achieving a weight management goal in the subject. Such a range of glucose amounts or concentrations typically comprises a high threshold glucose value and a low threshold glucose value. Rates of change (or trends) of glucose amounts or concentrations in the subject may be determined.

Many weight management programs recommend eating meals that strike a balance in the amounts of proteins, fats and carbohydrates eaten. These diets seek to maintain blood glucose levels within specified ranges by limiting the amount of carbohydrate and fat intake and balancing fats and carbohydrates with proteins. Frequent monitoring of blood glucose levels would allow subjects to determine which foods (and what combinations of foods) to eat at any given time so as to allow the subject to maintain specified blood glucose levels that are neither hyperglycemic nor hypoglycemic.

Using the methods described herein provides an excellent means for aiding subjects to monitor blood glucose levels and to maintain desired levels by eating and exercising appropriately. It is unlikely that traditional finger stick or current CMG methods will have the same impact.

In an embodiment, the monitoring of a glucose amount or concentration in the subject is accomplished by a glucose monitoring method comprising the following: transmitting a large spectrum of electromagnetic radiation through a sample to a receiver creating a series of spectral data sets that are then developed into a composite spectrogram by an analyzer and processed to determine the one or more characteristics of the sample. Alternatively, a magnetic field can be applied around the transmitter, receiver and sample to enhance some characteristic analysis applications and to make other characteristic analysis applications possible. With respect to humans, the sample is usually a finger or some other part of the body that can be inserted into or placed on a scanning apparatus for scanning purposes.

An embodiment is related to noninvasive systems and methods for scanning and analyzing one or more characteristics of a sample, including living and inert objects, utilizing electromagnetic radiation. In particular, an embodiment utilizes a large spectrum of electromagnetic radiation that is transmitted through a sample to a receiver that creates a series of spectral data sets that are then developed into a composite spectrogram by an analyzer and processed to determine the one or more characteristics of the sample. A magnetic field can alternatively be applied around the transmitter, receiver and sample to enhance some characteristic analysis applications and to make other characteristic analysis applications possible. With respect to humans, the sample is usually a finger or some other part of the body that can be inserted into or placed on a scanning apparatus for scanning purposes. Solids, liquids and gasses can all be measured using the same basic scanning apparatus and different types of delivery and control systems.

While a characteristic can be the sample's possession of some substance, feature, level, percentage, sui generis identity, etc., a characteristic could also be a class, species, genre or category. In other words, a characteristic could be almost anything. The characteristics that can be tested or scanned for

in humans and many other living samples include naturally occurring components of the blood, such as blood glucose levels, hemoglobin, cholesterol levels, proteins, red and white blood cell counts, lipids, C-reactive proteins, calcifications and hormone levels, as well as introduced components, such as steroids, pathogens, viruses, bacteria, yeasts and heavy metals, as well as many other biological markers, agents and substances, including biometric identifying markers and controlled substances such as illegal drugs, alcohol and poisons (all identified as “biometric markers” herein). For agricultural inspection purposes, meat and produce can be tested for characteristics indicating bacterial and other forms of contamination. In food processing operations, food products can be tested to regulate mixtures or the quantity of ingredients present, as well as to detect the presence of foreign elements such as metal, blood, nuts, milk and other allergens.

In security applications, unknown substances can be tested to determine their identity, such as illegal drugs, prescription drugs, explosives, poisons and bacterial agents (e.g., anthrax, nerve agents, etc.). Similarly, environmental substances can be scanned and identified in a wide variety of other applications, including biohazard and hazardous material situations, analysis of drinking water for pollutants, contaminants, minerals, and bacteria, and the analysis of air, water and ground (e.g., dirt, minerals, etc.) samples for similar substances. In manufacturing operations, materials can be tested to regulate or control the mixtures of substances, such as plastic, synthetics and petroleum, and the exhaust or byproducts of manufacturing operations can be analyzed to alert an operator of various different conditions, such as a malfunction.

Liquids can be identified for many different purposes, such as in airport security, stadium security or other security operations, or even authenticity, i.e., scanning a bottle of corked wine or sealed liquor to determine its identity, its condition or possibly even its age. Conversely, many substances and combinations of substances, such as certain liquids, can be tested to confirm whether they are what they are claimed to be. For example, when an airport traveler claims a clear liquid to be water, the liquid can be tested to determine whether it is water, and if it is not, the liquid and/or the traveler could be held for further investigation. Likewise, the authenticity of many other objects, such as money, bonds, antiques, documents, etc., can also be verified.

Referring now to FIG. 1, an embodiment and its many applications will be described in greater detail. FIG. 1 is a block diagram illustrating the transmission, reception and analysis systems of an embodiment. The CPU 10, I/O 12 and memory 14 can be configured as standalone components when utilized in some applications or incorporated into a larger computer system 16 for use in other applications. For example, some scanning applications may require an embodiment to be contained within a small, handheld, battery-powered unit that performs a limited application and only requires minimal processing, memory and data handling capabilities (See FIG. 6 for an example of such a device), while other applications may enable computer 16, incorporating the CPU 10, I/O 12 and memory 14, to be located away from the sample, thereby making many more applications possible.

Either the CPU 10 or the computer 16 is further connected to a transmitter 18 and a receiver 20, either directly as shown in FIG. 1 or through the I/O 12. The transmitter 18 is preferably capable of generating electromagnetic radiation across a broad spectrum. While many applications only require a frequency sweep between about 1 MHz to about 20 GHz, additional information about a sample and its characteristics can

be achieved utilizing frequency sweeps in ranges from as low as about 9 kHz, or lower, and as high as about 810 THz, or higher.

When the frequencies for a particular sweep enter the visible, infrared or other portions of the spectrum, different or additional transmission nodes and other equipment, as described further below, would be required in order to transmit such signals. Naturally, the receiver 20 must also be capable of operating in the same frequency ranges as the transmitter 18.

The type and arrangement of the nodes would also be impacted by the object being scanned. For example, while it might be possible to utilize an infrared transmitter and receiver placed on either side of a liquid or gaseous object, a more solid or opaque object might block the transmitted infrared signal from being detected by the receiver node. In such a case, it might be necessary to have the transmission node also operate as the receiver node, or to place the transmission node and the receiver node on the same side of the object, such that a deflected signal could be detected. Alternatively, a lower harmonic of the visible light signal could be utilized in place of the visible light signal. For example, if it were known that an element or characteristic of a gas or liquid could be detected using a visible light signal, that same element or characteristic should be detectable at a lower harmonic of the visible light signal, even though the distinguishing features of the element or characteristic would have a substantially lower magnitude and might be difficult to perceive in the lower harmonic signal.

As illustrated in FIG. 1, one or more transmission nodes 22 are connected to the transmitter 18 and used to transmit the electromagnetic radiation and one or more receiver nodes 24 are connected to the receiver to receive the electromagnetic radiation once it has been transmitted through or reflected by the sample, or reflected by the node itself. One embodiment of the invention provides antenna components that can be utilized for both the transmission node and receiver node, but at higher frequency levels, non-antenna transmit/receive components may be required.

One possible configuration of the transmission nodes 22 and the receiver nodes 24 is illustrated in FIG. 2, which provides a partially cut-away perspective view, with hidden lines, of a sample scanning apparatus 30 in conformity with an embodiment. The sample module and scanning module or apparatus illustrated in FIG. 2 is designed for scanning applications where the sample to be tested, such as a finger of a human, or similarly shaped object such as a test tube or sample container, is placed inside the scanning apparatus 30. The base or bed 32 of the scanning apparatus is shaped in such a way that a finger or object placed within the scanning apparatus 30 will be held in a consistent position. Additional guides or stops can be arranged inside and outside the scanning apparatus to ensure constancy of placement of the sample. For example, as illustrated in FIG. 2, the back wall 34 of the scanning apparatus 30 acts as a stop for the finger or object placed inside. The bed 32 is comprised of a left arm 36 and a right arm 38 with an angled or rounded central guide wall 40 formed there between. The rounded shape of the guide wall 40, in this particular application, helps to further ensure consistent placement of an inserted finger or similarly rounded object.

The bed 32 is formed from a material that has a low dielectric constant D_k (as close to 1 as possible), such as a cross-linked polystyrene, like REXOLITE 1422 (a trademark of C-Lec Plastics Inc.). In such materials the change in D_k is negligible with temperature fluctuations. Although REXOLITE 1422 is presently used, other materials could also be

11

utilized and even some materials with higher dielectric constants or other properties not present in REXOLITE 1422 could enhance some applications. REXOLITE 1422 is a thermoset, rigid and translucent plastic with a dielectric constant of 2.53 (up to 500 GHz) and an extremely low dissipation factor. The performance characteristics of the REXOLITE 1422 bed **32** enables the transmission node **22** and the receiver node **24** to be placed or embedded directly in the bed **32**. The nodes **22** and **24** are spaced apart so as to enable a finger or object to be placed between the two nodes, such that any signal transmitted from the transmission node **22** would go through the finger or object to reach the receiver node **24**. Highly shielded transmission lead **23** connects the transmission node **22** to the transmitter **18** and highly shielded receiver lead **25** connects the receiver node **24** to the receiver **20**.

The shape and arrangement of the nodes **22** and **24** are application specific. As illustrated in FIG. 2, the arrangement of the nodes **22** and **24** and the other components of the scanning apparatus **30** are utilized for biometric testing, glucose level testing and similar types of applications. This same arrangement can be utilized to identify an unknown fluid contained within a test tube or sample container, but a different configuration of the sensor, as illustrated below, may be desirable for such applications.

Still, other applications might require different types of nodes **22** and **24**, as well as other equipment, which might need to be arranged differently, to achieve the best results. For example, at high frequencies, such as 810 THz, many changes would be required of the scanning equipment, not just the nodes. For example, in the scanning device illustrated in FIG. 2, the transmission lead **23** and the receiver lead **25** presently utilize 50 ohm cables to carry power to the nodes. The reactive impedance from the nodes to the ground plane of the scanning apparatus **30** (not shown) through the base **32** has been minimized to about 50 ohms at 12 GHz. This impedance is determined by the capacitance of area and spacing of the nodes to the ground plane and the dielectric constant of the REXOLITE 1422 base **32**. Since reactive impedance varies as 1/frequency, at higher frequencies, very little power could be transmitted through such leads. Hence, at higher frequencies, very different equipment will be required to make the scanner operate effectively.

The shape, orientation and material composition of the nodes can also improve the performance characteristics of the scanning apparatus **30**. An embodiment of shape and material composition of either of the nodes **22** and **24** is further illustrated in FIG. 3, which is a partially broken, cross-sectional view of either a transmission node or a receiver node. As shown in FIG. 3, the node is comprised of a metal base **300**, such as solid brass with gold plating, although other non-reactive or low reactive metals or alloys could be utilized for the plating. The antenna **302** for the node is inserted into the base **300** through an opening **304** formed in the base **300**. A polytetrafluoroethylene sleeve **306**, or a sleeve formed from other similar substances, fits around the antenna **302** until the antenna **302** enters a narrowed or tapered portion of the opening **304** near the top of the base **300**.

To secure the antenna **302** to the base **300** and to provide an electrical connection between the antenna and the base **300**, the top **308** of the antenna **302** is prick punched and affixed with a silver epoxy, although many other manners of securing and connecting the antenna **302** could be utilized. To affix or secure the base **300** to the bed **32**, a REXOLITE 1422 screw or post **310** is inserted into a second opening **312** formed in the base **300**, which screw or post **310** is in turn affixed or secured to the base **32**.

12

The orientation and location of the nodes **22** and **24**, relative to one another and/or to a finger or object to be analyzed, can also affect the performance of the scanning device. As illustrated in FIG. 2, nodes **22** and **24** are arranged and oriented within the bed **32** so as to enable the majority of most human index fingers to rest within the bed while making contact with both nodes **22** and **24**. Likewise, an object to be analyzed could be shaped or placed within a container, such as a specially shaped container formed from a material such as REXOLITE 1422 that would enable the object to rest within the bed **32** in contact (perhaps through the container) with both nodes **22** and **24**. In some applications, contact between the finger or object to be analyzed and both nodes **22** and **24** is not necessary to enable detection of an adequate signal at the receiver node **24**, but in other applications such contact can make a significant signal quality difference.

Although FIG. 2 illustrates an embodiment with a single transmission node **22** and a single receiver node **24**, which enable the creation of spectral data sets for analysis by the CPU **10**, additional nodes can be utilized to create additional spectral data sets for additional analysis. For each N number of transmission nodes **22** and M number of receiver nodes **24**, a total of at least N×M, or likely many more, spectral data sets become possible. The nodes **22** and **24** can also be arranged in arrays of two or more nodes to create further spectral data sets for analysis. As used herein, the terms “spectral data set” or “spectral data sets” refer to any spectra collected at a particular frequency or sample point, even if there is only a single spectrum at any such frequency or sample point. Further, as used herein, the term “composite spectrogram” refers to any collection of spectral data sets into a data file, regardless of whether that data file is then used to generate an image of the combined spectral data sets within the data file or is processed in its raw form by one or more algorithms to generate an output based on the combination of spectral data sets.

As further illustrated in FIG. 2, the bed **32** (including the nodes **22** and **24**) is enclosed within a closed-top housing **42** that provides structural stability for the scanning apparatus **30**, provides a clear opening for insertion of the finger or object to be tested, and that provides electrical shielding. The housing **42** could also be open-top, either partially open around the area in which a finger or object to be tested would be placed, or completely open on the top. The housing **42** could be differently shaped as well, as further described below.

A housing **42** composed of a shielding material and providing somewhat less than 360 degree coverage, as illustrated in FIG. 2, would allow for simple insertion of the finger or object, would reduce electrical noise, and would reduce environmental interactions with any magnetic field generated within the housing, as further described below. The housing **42** would also include a base portion (not shown in FIG. 2) below the bed **32**, magnets **44** and **46**, and blocks **48**, **50** and **52**, to complete the housing enclosure.

The housing **42** could be formed of REXOLITE 1422 or other materials, such as aluminum or copper. Alternatively, if the housing is to be used to also provide magnetic shielding, the housing **42** could be made somewhat larger to provide a sufficient gap or spacing from the magnets **44** and **46**, at least 0.3 inches, and be fabricated from soft iron, mu-metal (a nickel-iron alloy (from about 65% to 85% nickel, from about 5% to 25% iron, plus copper and molybdenum) that has a very high magnetic permeability) or other similar metal of sufficient thickness to prevent saturation of the metal. The housing **42** could also be fabricated to include RF shielding, such as an

attunement shield that tunes in or out certain frequencies to deaden or enhance information in the composite spectrograms.

The scanning apparatus 30, as illustrated in FIG. 2, also includes magnets 44 and 46 positioned on the outside of arms 36 and 38 that form a magnetic field around the nodes 22 and 24 and the object to be tested. For some applications of the scanning apparatus 30, the magnetic field created by the magnets 44 and 46 is completely irrelevant and the magnets should not be utilized. In other applications, the magnetic field enhances the analysis of the composite spectrograms, but is not required. In still other applications, such as glucose testing, the magnetic field appears to be required to generate more usable spectral data sets.

When a magnetic field is desirable, high-gauss permanent bar magnets, made of a Neodymium compound ($\text{Nd}_2\text{Fe}_{14}\text{B}$), cylindrically shaped of dimensions of about 1.25 inches long by about $\frac{5}{8}$ inches in diameter of 50 MGOe (Mega Gauss Oersted) are used, although other magnets of different compositions, shapes, and strengths and even nonpermanent magnets (created using electromagnetism) could be utilized. The shape, position, strength and number of magnets 44 and 46 utilized is important with respect to configuring the position of the magnetic field relative to the transmission node 22 and receiver node 24 and the sample to be tested, and the intensity of that magnetic field. FIG. 2 illustrates an embodiment with magnets 44 and 46 positioned on the outsides of arms 36 and 38 and held in place on the sides of the magnets 44 and 46 by REXOLITE 1422 blocks, such as block 48 and blocks 50 and 52 illustrated with hidden lines. A block corresponding to block 48 would be positioned next to magnet 46, but is not visible in FIG. 2 due to the presence of the housing 42.

The position of the magnets 44 and 46 as illustrated in FIG. 2, with the north pole of magnet 44 and the south pole of magnet 46 facing the front of the scanning apparatus 30 and the south pole of magnet 44 and the north pole of magnet 46 facing the rear of the scanning apparatus 30, creates a magnetic field that surrounds the nodes 22 and 24 and any portion of the sample to be tested that is positioned between the nodes. As configured, the magnetic field near the rear of the nodes 22 and 24 is near zero and drops to zero about 1 mm from the back of the nodes towards the rear of the scanning apparatus 30. The magnetic field strength near the front of the nodes 22 and 24 and to a position about midway between the nodes is on the order of about 300 gauss. This particular magnet/node configuration is utilized in the scanning device 30, as noted above. Other applications and other scanning apparatuses, however, might achieve better results with different configurations or compositions of magnets and nodes, such as illustrated in FIGS. 4A-4H.

FIG. 4A is a partially exploded, perspective view of an alternative embodiment of the scanning apparatus illustrated in FIG. 2. The scanning apparatus 400 of FIG. 4A is comprised of one set of nodes and two sets of magnets. A base 402 supports a finger guide 404, made of REXOLITE 1422 or a similar material, and a riser plate 406. Riser plate 406, which is formed of a brass material and which operates as the RF ground return, supports a bed 408 with a central trough 410 and a first node set 412 comprised of a transmission node 414 and a receiver node 416. The bed 408 also supports a stop 418, which operates in conjunction with the shape of the finger guide 404, the trough 410 of the bed 408, and the first node set 412 to position a finger, sample or object in the correct position and orientation within the scanning apparatus 400.

A housing 420 fits over the top of the base 402 to complete the enclosure and to provide a magnetic field through the nodes and sample in addition to RF and/or magnetic shield-

ing, when needed. Housing 420 also forms an opening 422 through which a finger, sample or object could be inserted. The housing 420 also supports two sets of magnets that are affixed to the opposite inner sides of the housing. Only magnet 424, of a first set of magnets, is illustrated in FIG. 4A, affixed to the left inside wall 426 of the housing 420, with the south pole 428 of magnet 424 facing the inside of the scanning apparatus 400. Another magnet, with its north pole facing inward would be positioned on the right inside wall of the housing 420 opposite magnet 424. Likewise, a second set of magnets, not shown, would be similarly affixed to the inside walls of the rear of housing 420, facing in opposite directions and with their poles reversed in comparison to the first set, i.e., the magnet on the same side of the housing 420 as magnet 424 would have its north pole facing the inside of the scanning apparatus 400.

FIG. 4B is almost identical to FIG. 4A, but includes a second node set comprised of a second transmission node 430 and a second receiver node 432. With respect to both FIGS. 4A and 4B, the base 402 is about 2.20 inches wide, about 3.20 inches deep, and about 0.10 inches thick. The housing 420 is about 1.67 inches tall at the front. All of the remaining parts of the scanning apparatus 400 are scaled accordingly. The scanning apparatus 30 of FIG. 2 is similarly sized. Of course, other sizes and configurations are possible and might be preferred for different scanning operations. Accordingly, an embodiment anticipates many other possible sizes and configurations and is not limited by the sizes and configurations illustrated herein.

FIG. 4C illustrates another alternative embodiment of the scanning apparatus illustrated in FIG. 2. The scanning apparatus 440 of FIG. 4C has at least an upper portion that is cylindrically shaped. The base of the scanning apparatus may have a rectangular base, allowing the scanning apparatus to stand and be stable on a flat surface. The scanning apparatus consists of a cylindrical housing 441 to provide enclosure and to provide a magnetic field around the nodes and the sample in addition to RF and/or magnetic shielding, when needed. Housing 441 also forms a finger opening 442 in the front and a second opening (not shown) in the rear of the apparatus. The housing 441 and the base (not shown) of the scanning apparatus 440 are held firmly in place by a first face plate 443 and a second face plate 452 on the opposite end (shown in FIG. 4D). The first face plate 443 and the second face plate 452 can be attached to the housing 441 and the base with one or more screws, by welding, or other suitable methods well known in the art.

The first face plate 443 can be part of the magnetic shield contained in the housing 441. The first face plate 443 and the second face plate 452 may have rectangular bottoms, further allowing the scanning apparatus 440 to stand firmly. A finger guide 444 is attached to the first face plate 443. The finger guide 444 can be made of a material with a low dielectric constant, such as REXOLITE 1422. A base or bed 445 of the scanning apparatus is shaped in such a way that a finger or object placed within the scanning apparatus will be held in a consistent position. Additional guides or stops can be arranged inside and outside the scanning apparatus to ensure constancy of placement of the sample.

In contrast to the antennas illustrated in FIGS. 2, 3, 4A and 4B, the scanning apparatus 440 of FIG. 4C employs dipole antennas. A first dipole antenna 446, having two electrode halves, and a second dipole antenna 447, having two electrode halves, span along both sides of the inside of the scanning apparatus 440 just above the bed 445. The center conductor of the semi-rigid coaxial RF connector 448 is connected (via soldering or similar means) to the back half of

the dipole electrode **446**, while the metal shield of the coaxial RF connector **448** is connected to the front half of dipole electrode **446**. On the opposite side, the center conductor of coaxial RF connector **449** is connected to the front half of the dipole electrode **447** and the metal shield of the coaxial RF connector **449** is connected to the rear half of the dipole electrode **447**. The coaxial RF connectors **448** and **449** are then routed within the scanning apparatus **440** to the rear of the unit.

A first set of magnets **450** are placed below and along the length of the base **445**. A second set of magnets (not shown) are placed on the inside of the top of the housing **441**, directly opposite the first set of magnets **450**. The first set of magnets **450** consists of three magnets, with the north pole of the magnets facing up. The second set of magnets is aligned with the corresponding first set of magnets **450**, with the south pole of the second set of magnets facing down. The first set of magnets **450** can also have the south pole of the magnets facing up, with the second set of magnets having the north pole of the magnets facing down. A different number of magnets can be used to obtain various behavior performances of the scanning apparatus **440**. For example, two magnets can be used for the first set of magnets and two magnets can be used for the second set of magnets, etc. In an embodiment, the first set of magnets would cover the entire base **445**. In another embodiment, the first set of magnets would cover only a fraction of the base **445**. The shape of the magnets can also be varied. The magnets used can be round shaped, oval shaped, or pellet shaped. By having the magnets placed along the base, instead of along one of the side walls as illustrated in FIGS. **2** and **3**, it results in the magnetic field being perpendicular to the electric field, the electric field generated by the signals being transmitted from the transmitter nodes to the receiver nodes. Such arrangement improves the amount of energy absorbed by the tested sample, and consequently improves the accuracy of the resulting readings. As previously noted, magnets may not always be necessary.

In an embodiment of the scanning apparatus **440**, the first dipole antenna **446** and the second dipole antenna **447** are in direct contact with the sample placed within the scanning apparatus **440**. In an embodiment, the dipole antennas **446** and **447** may be shielded in some manner from the sample placed within the scanning apparatus **440**, to prevent the dipole antennas from coming in direct contact with the finger or object. For example, the dipole antennas **446** and **447** may be placed further up on the side walls of the scanning apparatus **440**, instead of being placed in closer proximity to the bed **445** or next to the bed **445**. The dipole antennas **446** and **447** may also be shielded with a material with a low dielectric constant, such as REXOLITE 1422.

FIG. **4D** shows the back of the scanning apparatus **440**. The second opening **451** allows for a tube to be passed through the scanning apparatus **440** when in use with the flow through sensor, further discussed herein. Alternatively, the scanning apparatus **440** without the second opening **451** can be used if testing samples without the need for the flow through sensor. A second face plate **452** is attached to the scanning device. One or more screws **453** can be used to anchor the base **445** and to keep the base **445** from moving. The screws **453** can be made of plastic or from a material with a low dielectric constant. A finger stop **454** allows for a finger or object to be inserted through the first opening **442** up to the point where the finger comes in contact with finger stop **454** on the inside of the scanning apparatus **440**. The finger stop **454** is substantially T-shaped; however, any other shape that serves as a stopper indicator can be used to provide consistent positioning within the scanning apparatus **440**. The finger stop **454**

can be a removable piece, allowing for use of the scanning apparatus **440** with the flow through sensor described below. The finger stop **454**, while described as a stop guide for fingers, also serves the same purpose with other objects. For example, if a liquid sample was being tested, the liquid sample could be placed in a test tube, with the finger stop **454** used for informing users how far to insert the test tube into the scanning apparatus **440**. In an embodiment, the finger stop **454** could move along a horizontal axis, allowing for the finger stop **454** to be moved further inside of the scanning apparatus **440**. This would allow for the finger stop **454** to be adjusted based on the size of the sample being inserted into the scanning apparatus **440**.

In an embodiment, the finger stop **454** can be circular shaped and completely shield the second opening **451**. This finger stop **454** could also be a removable piece. The finger stop **454** can also have a rectangular shape, or any other shape which completely shields the second opening **451**.

A set of RF connections **455** connect the dipole antennas with the transmitter **18** and receiver **20**. The dipole antennas can transmit and receive data. For example, a first RF connection **456** can connect the first dipole antenna **446** with the transmitter **18** and a second RF connection **457** can connect the second dipole antenna **447** with the receiver **20**. A commercially available network analyzer (not shown) could be used to perform the functions of the transmitter **18** and receiver **20**. Two sets of semi-rigid coaxial cables (not shown) within the scanning apparatus **440** connect the first dipole antenna **446** and the second dipole antenna **447** with the RF connections **455**, respectively. By removing the second face plate **452** and the screws **453** (along with other screws that are not shown), it is possible to remove the internal portion of the scanning apparatus **440** holding the dipole antennas **446** and **447**, along with the semi-rigid coaxial cables and their RF connectors **448** and **449** so the dipole antennas **446** and **447** and other internal components of the scanning apparatus **440** can be modified without having to take the entire apparatus apart.

FIGS. **4E** to **4H** illustrate an embodiment of the flow through sensor **460**. The flow through sensor **460** consists of a mixing tank **461**, including a screw cap **462**. The test fluid that is being analyzed or identified is added to the mixing tank **461** by removing the screw cap **462** and pouring the liquid into the mixing tank **461**. The test fluid added to the mixing tank **461** then circulates via a tube **463** (shown in FIG. **4E**, but identified in FIG. **4H**) into a pump **464** (shown in FIG. **4H**). The pump **464** pumps the test fluid out through the tube **465** into the temperature control unit **466**. The temperature control unit **466** may be opened with a lid **467**. The temperature control unit **466** can cool or heat the flowing test fluid to a set target temperature specified by a computer controlled controller **468**. The controller **468** interfaces with a computer via a wired or a wireless connection to allow the temperature control unit **466** to be managed via program control.

The test fluid circulates out of the temperature control unit **466** through tube **469** into a Pyrex tube (shown, but not separately identified in FIGS. **4E** and **4G**) with the Pyrex tube carrying the test fluid through the scanning apparatus **470**. Any other material alternative to Pyrex which does not interfere with the signals being sent from the transmitter nodes to the receiver nodes can also be utilized, such as REXOLITE 1422 or some similar substance. One or more clamps **471** and **472** can be used to secure the Pyrex tube to the tube **469** carrying the incoming test fluid and the tube **473** carrying the outgoing test fluid. Additional clamps (some shown, but not separately identified in FIGS. **4E** and **4G**, and some not vis-

ible behind the scanning apparatus 470) serve to secure the Pyrex tube relative to the scanning apparatus 470.

The test fluid passes through the scanning apparatus 470 and circulates through the tube 473 back into the mixing tank 461. Measured solute additions can also be added to the liquid in the mixing tank 461 by removing the screw cap 462 in order to calibrate the flow through sensor over a range of solute concentrations. Stirring and dissolving of the solute in the liquid occurs naturally due to the pumping and flowing action and complete dissolution of the solute additions can easily be detected over time by comparison of successive scans taken a few minutes apart. Complete dissolution becomes evident when successive scans become essentially identical.

The scanning apparatus 470 connects to the transmitter 18 and receiver 20 through the connections 474. The test fluid in the mixing tank 461 may be flushed via a tube 475. The length of the Pyrex tube depends on the corresponding size of the scanning apparatus 470. It is important for the Pyrex tube to traverse the entire length of the scanning apparatus 470. The width of the Pyrex tube can be varied depending on the test fluid used or based on alternative settings and the size of the openings in the scanning apparatus for receiving the Pyrex tube. For example, using a smaller Pyrex tube and smaller tubing for the flow through sensor 460 requires the use of less test fluid. For example, if the test fluid was a blood sample, smaller overall tubing and a small Pyrex tube would probably be necessary in order to minimize the amount of test fluid needed to be added to the flow through sensor 460.

As previously noted, split clamps (not specifically identified) serve to immobilize the Pyrex tube within the scanning apparatus 470 and to allow for certain constant conditions within the scanning apparatus 470 associated with movement of the Pyrex tube while the sample is being scanned. Other variations including temperature, humidity, and pressure differences are removed through use of the temperature control unit 466 and the closed loop system, which enable constant conditions. Positioning and repositioning errors and applied pressure (such as pressure applied to the Pyrex tube during a scan) errors are nonexistent. The flow through sensor 460 removes these variables, only allowing for the variation of the test fluid and desired temperature variations. In an embodiment, a dielectric can be placed between the Pyrex tube and the dipole antennas within the scanning apparatus 470.

Stainless steel tubing 476 contained within the temperature control unit 466 circulates the fluid allowing for accurate temperature control of the fluid. The tube 465 connects to one end 477 of the stainless steel tubing 476 and a second end 478 of the stainless steel tubing 476 connects to the outgoing tube 469. This allows for the test fluid to have a constant and precise temperature as it flows through the scanning apparatus 470, thus removing errors due to fluctuations in temperature.

The data collected from the flow through sensor 460 is highly accurate and stable, with low standard deviations in the generated data, due to the controlled environment and the temperature control. In an embodiment, the flow through sensor 460 can be used, with or without the temperature control unit 466, for quality control in industrial settings. For example, fluids or chemicals produced in an industrial setting can be bled off from other equipment, pipes, tubing, etc., to check for quality or in order to identify foreign matter or chemicals by running fluids or chemicals through the flow through sensor 460. The flow through sensor 460 can be scaled accordingly in order to accommodate for a higher throughput. The speed of the flowing fluid running through the flow through sensor can also be varied by adjusting the pump or pumps 464 and the size of the tubing.

The flow through sensor 460 can also be used for testing blood samples, urine samples, and other bodily fluids. As noted above, the size of the tubing used in the flow through sensor 460, as well as the Pyrex or other tube inserted into the scanning apparatus 470, can be adjusted to accommodate for smaller quantities of fluid, such as blood samples. The data collected from blood samples flowing through the scanning apparatus 470 can be analyzed by one or more algorithms that detect various chemicals or substances in the blood samples, as further discussed herein. The flow through sensor 460 can detect properties of samples by analyzing the spectra data sets produced by the scanning apparatus. This is in contrast to bodily fluid tests which detect certain properties or chemicals in bodily fluids by applying foreign chemicals or catalysts and looking for a color change, or some other quantifiable change. The flow through sensor 460 can detect properties of the bodily fluids without applying any foreign chemicals or catalysts to the sample.

While each of the different scanning apparatuses could be used for applications the same as or similar to other scanning apparatuses, the arrangement of different node and magnet sets would create different spectral data sets in each case and would therefore create different useful applications. For example, scanning apparatuses 30 and 440 are particularly well suited for glucose and blood scanning applications in situ, a smaller-sized device might be more desirable for biometric identification. It has been found that even minor changes in the dimensions, angles, materials, shapes and other features of the magnets, nodes and other components of the scanning apparatuses, as well as the position of the sample to be tested, the frequencies used by the scanning apparatuses, the strength of magnets if utilized, the temperature of the sample, the ambient temperature, ambient humidity levels, whether the sample is in contact with the nodes, the volume of the sample, and many other factors can have a small to significant impact on the performance of the scanning apparatuses and the analyzer.

It is therefore necessary to perform a tuning operation with each new configuration of a scanning apparatus and its components, the electronics, and the analyzer in order to get the best results. At the present time, a certain amount of trial and error is required to tune each scanning apparatus for a particular application. For example, in glucose level scanning, the subject's finger should typically be in contact with both nodes and a magnetic field should be used. It may be possible, however, to find a particular arrangement or configuration of the components within the scanning apparatus that will remove the need to have the subject's finger in contact with the nodes, or to use the magnetic field.

In other tests, neither of these requirements may be necessary. For example, in some manufacturing applications where a fluid or gas is being tested for its composition, it may be preferable to insulate the nodes from the fluid or gas, as is done by the Pyrex tube of the flow through sensor 460, so that there would be no contact between the matter being tested and the nodes. In some applications, the magnetic field is not required, but the presence of the magnetic field may substantially enhance the performance of the scanning apparatus.

For many of the applications of the scanning apparatuses, the method of sampling would be similar, but many alternative embodiments would be possible for alternative applications. In a finger scanning application, a direct sample scanning application (where the sample is appropriate to be placed directly into the scanning apparatus), or where the sample can be placed inside a container that can then be placed inside the scanning apparatus, it is preferable to place the finger, sample or container in direct contact with the transmission node and

the receiver node. Such direct contact helps to improve or enhance the quality of the signal received by the receiver node after passing through the sample, such as through reduction in the amount of other signals (noise) that can be picked up by the receiver node at the same time and the amount of power loss (reduction in amplitude) in the received signal. In other applications, however, it might be more important to protect the nodes from dirt, oil, and wear and tear by covering them with a thin layer of dielectric material.

Once the sample is in position in or flowing through the scanning apparatus, a series of electromagnetic radiation signals covering a range or sweep of frequencies is transmitted from the transmission node(s) to the sample and to the receiver node(s). The amplitude of these signals can be the same or varied as different applications may require. This series of signals may be comprised of short signal bursts at each of a large number of distinct frequencies ("sample points") with small or large intervals between each frequency selected. In an embodiment a small set of specific frequencies or sample points may be used for specific applications where it is known that spectral data is only needed at those specific frequencies to analyze appropriate characteristics of the sample.

When scanning for glucose or blood sugar levels using the scanning apparatus 30, a frequency sweep between about 100 MHz and about 3 GHz is generally used, but frequency sweeps from about 10 MHz to about 2.7 GHz and about 0.3 MHz to about 20.1 GHz have also been used successfully. For biometric identification scanning, a sweep of about 0.3 MHz to about 20.1 GHz is used due to economics and physical configurations. Alternatively higher frequencies can be used, where utilizing higher frequencies requires a different physical configuration of the scanning apparatuses and requires significantly more computational power to process the resulting spectral data sets and composite spectrograms.

For many applications, the transmitter 18 could be a commercially available signal generator, such as the Agilent Technologies' Agilent E8257D PSG Analog Signal Generator, which is capable (when properly accessorized) of synthesizing signals with high output power (at least 20 milliwatts, based on a constant peak to peak RF voltage of one volt and impedance of 50 ohm) and low phase noise in ranges between about 250 kHz and about 325 GHz. Likewise, the receiver 20 could be a commercially available spectrum analyzer, such as the Agilent Technologies' Agilent ESA E4407B Spectrum Analyzer, which is capable (when properly accessorized) of receiving and analyzing signals in ranges between about 9 kHz and about 325 GHz. A singular network analyzer could be utilized to both generate and receive the necessary signals. More specialized equipment may be required to transmit and receive signals at lower or higher frequencies. Likewise, specific electronic circuitry capable of performing the same types of functions, in place of the signal generator and spectrum analyzer, could be developed for use in an embodiment.

Spectrum generators, analyzers and similar electronic circuitry are commonly used to generate signals and to examine the resulting waveforms. Many such devices allow the user to select the number of sampling points at which signals will be transmitted within a particular frequency range, thereby determining the selected frequencies as well as the intervals between those frequencies. For example, in a frequency range from 100 MHz to 12 GHz, some 3,201 sampling points could be selected (based on the capabilities of the equipment noted above and the compute time required to process that many sample points), although a different number of points could readily be utilized with the same or different equipment and greater computational power. In specially designed circuitry,

as noted above, it would be possible to specify the exact frequencies for each sampling point, which might give a user even further flexibility in terms of scanning a sample at the frequencies most likely to generate the most useful information.

The presence of the sample, and in particular the composition of the sample at the particular moments during scanning, modifies the amplitude of at least some of the signals transmitted through or reflected by the sample from the transmission node(s) to the receiver node(s). There are numerous possible explanations as to why the amplitudes of the signals are modified at different frequencies. In many cases, the amplitude is reduced, but in some cases, the amplitude is actually increased. It is possible that amplitude modification might result when electron spins are excited by the electromagnetic radiation, as well as the presence of a magnetic field, when utilized. But electron spin resonance is only believed to occur when a molecule has an unpaired electron, such as a free radical in an organic molecule or a transition metal ion in inorganic complexes, and since most stable molecules have a closed-shell configuration without a suitable unpaired electron, electron spin resonance or similarly electron paramagnetic resonance cannot be the only basis for amplitude modification. Additional amplitude modification could therefore result from proton spins of radiated atomic nuclei, or other phenomena.

It is also possible that additional amplitude modification could result when electromagnetic radiation is absorbed or emitted by molecules associated with a corresponding change in the rotational quantum number of the molecules, otherwise known as rotational spectroscopy or microwave spectroscopy. However, rotational spectroscopy is believed to only really be practical when molecules are in the gas phase where the rotational motion is quantized. In solids or liquids, the rotational motion is usually quenched due to collisions. Dielectric/dipole oscillation or rotation (dielectric spectroscopy or impedance spectroscopy) would also appear to be occurring to some degree, possibly coupled with one or more of the other phenomena noted above.

The amplitude modifications have particular meaning with respect to certain characteristics of each sample that can be determined from careful analysis of the resulting spectral data sets (as described below). This point is particularly important with respect to distinguishing an embodiment from numerous prior art techniques in which a composite signal is employed, but usually only at one or two frequencies are examined, to determine the presence of an analyte. These prior techniques do not look at a composite spectrogram, which represents an amassed congeries of data collected at many different frequencies, in order to perceive subtle quantitative relationships within that composite spectrogram or between compared composite spectrograms.

In all scanning apparatuses, even those with a single node, a single pair of nodes, or multiple transmission and receiver nodes, frequency sweeps could be further varied. For example, a first signal could be transmitted from a first transmission node and only detected by a directly, physically corresponding first receiver node, and then a second signal could be transmitted from a second transmission node and only detected by a second receiver node that directly, physically corresponds to the second transmission node, etc. Since all transmission nodes are also capable of receiving, it is also possible to transmit from one node and receive on all of the nodes, including the transmission node. Thus, it would be possible to transmit from a first node, receive on three other

nodes and the first node, transmit on a second node and received on the first node, the second node, and two other nodes, etc.

Alternatively, the first signal could be transmitted from the first transmission node, but only detected by the second receiver node, while the second signal is transmitted from the second transmission node, but only detected by the first receiver node, etc. Additional arrangements of nodes and magnets (if used), including arrays of nodes, could create countless additional variations, including the transmission from a first transmission node and near simultaneous detection by multiple different receiver nodes.

Likewise, although a consistent orientation and position of the sample to be tested has so far been discussed, the position and orientation of the sample could also be varied from test to test or within a single test. For example, a sample could be placed in the scanning apparatus in a first position, then scanning would be performed, then the sample would be rotated by some number of degrees (45°, 60°, 90°, 180°, etc.), and scanning would be performed again. This would result in multiple composite spectrograms that could be used to improve performance or the reliability of identity scanning, etc.

The position of the sample in the scanning apparatus could be further changed by varying the extent of insertion into the scanning apparatus for each test. For example, a finger could be inserted at a first position, where maybe just the finger tip is in contact with a first set of nodes, and then inserted further to a second position, where the first knuckle is in contact with the first set of nodes, etc. In biometric identity scanning applications, position and orientation variations, as well as scanning variations, could be used to increase the distinctive information that is collected regarding the subject. Additional samples, such as a second finger, could also be used to enhance scanning.

Details of the analysis of a scanning application are described with reference to FIG. 5, which illustrates a composite spectrogram signal that is used for glucose level testing in accordance with an embodiment. As disclosed in the '048 patent, the contents of which is incorporated by reference herein, it is known that a change in the magnitude of an RF signal transmitted through a finger occurs at about 2.48 GHz and that this change in magnitude correlates to the concentration of glucose or blood sugar in the finger. However, the '048 patent relied upon basic pattern matching at the specified frequency with previous tests to make a determination about a current test and a subject's current glucose level.

As illustrated with respect to FIG. 5, an embodiment utilizes real-time pattern recognition analysis to make determinations about the glucose levels of the subject represented by the composite signal. The pattern recognition analysis is based on additional information found at other frequencies in the composite signal (other than about 2.48 GHz), together with additional data about the subject to be tested. The scanning apparatus of an embodiment enables certain characteristic patterns to be detected that are common to subjects with high, normal and low glucose levels. Additional patterns also indicate when a subject is exerting excessive pressure on their finger or when their finger is not properly placed within the scanning apparatus. Still further patterns indicate when a subject has moved their finger during scanning or when a subject's finger is not oriented in the optimal position. Finally, the size of a subject's finger can result in significant variations in the composite signal, which variations can be diminished by accounting for the greater blood volume that

exists in large fingers and the lesser blood volume that exists in small fingers, such as through measurement of the finger to be tested at a common point.

As a result, the analysis of the composite spectrogram signal of an embodiment, performed by software or specialized hardware within the computer 16, takes advantage of real-time software pattern recognition analysis in order to perform accurate analysis of a just-in-time captured composite spectrogram signal. This method of analysis of the composite signal enables more complex determinations to be made about the information represented by the composite signal. More importantly, this method of analysis enables rapid determinations about a subject's glucose level. Hence, a scanning device incorporating this technology could be placed in homes, businesses and common areas of stores, much like current blood pressure testing devices, and enable anyone utilizing the device to obtain an accurate measure of their current glucose level.

Other devices, such as portable scanning devices that do not require pin pricks, which could be put in a pocket or purse, would make many other types of applications possible. For example, since the quantity of glucose or blood sugar in a person's body at a given point in time is representative of the calories they have consumed and utilized as a result of exercise or simply living, their blood sugar level correlates well to their weight or performance management. If their blood sugar levels are higher than a normalized level, they may be in a position to gain weight, while if their blood sugar levels are lower than a normalized level, they may be in a position to lose weight. While this correlation is well known and incorporated into a number of weight management plans, prior art blood sugar testing devices have not made it practical to test someone's blood sugar levels multiple times a day to help manage their caloric intake and utilization. Embodiments change this situation, however, by enabling a user to carefully test and manage their caloric intake and utilization many times during the course of a day, thereby enabling use by anyone desiring to control their weight, including athletes, dieters, etc.

Likewise, an athlete's performance could be optimized through use of such a device by carefully monitoring blood sugar levels to make sure the athlete had the optimum amount of fuel for energy in their body at a needed time.

By coupling the blood scanning features of an embodiment to a computer equipped with additional weight management software, a user could track their weight gain or loss over a period of time, but without being relegated to making rough guesses about calories consumed, through food and drink, and utilized, through normal body functions and exercises performed. Performance management software could play a similar cooperative role. Alternatively, an embodiment could be coupled with a calorie counting type of diet, so as to prevent the user from straying from reality (i.e., "that donut was only 50 calories" or "I only had a half portion"). Certain safety features could also be incorporated if a user was consuming too few calories over a period of time or exercising too much, such as by disabling the scanning device and/or sending a message to a central office so as to enable a person to check on the user.

With reference now to FIG. 5, an example of just-in-time composite signal analysis, in conformance with an embodiment, is provided. The composite signal illustrated in FIG. 5, which is generated from a large set of spectral data sets, is representative of the type of signal generated during a glucose level test. The graph of the composite spectrogram signal 500

in FIG. 5 represents frequency, in Hertz (Hz), along the horizontal axis and differential amplitude, in decibels (dB) along the vertical axis.

The power or magnitude of the resulting composite signal is represented in decibels. The term “differential amplitude” is used to refer to the normalized amplitude signals that are generated by performing a scan first without a sample, performing a scan with the sample to be tested, and then subtracting the amplitude versus frequency results of the first scan from the results of the second scan. As illustrated in FIGS. 5, 7 and 8, the zero differential point is shown by the “0” at the approximate midpoint of the vertical axis in each graph.

There are four pattern components to the composite signal 500, and a fifth factor, a measure of the blood volume of the subject’s finger, which are used to determine the subject’s glucose level from the composite signal 500. When scanning for blood glucose levels, it is very important to determine at least a rough determination of the blood volume of the subject’s finger, i.e., the size of the finger, at the point of measurement because smaller than normal and larger than normal fingers can skew the results if the resulting blood volume (less for small fingers and more for large fingers) is not taken into consideration.

Hence, the cross-sectional area of the finger at the approximate point of contact with the nodes is determined. This determination can be made in any of a wide variety of fashions, such as measuring the subject’s finger with a piece of measuring tape, matching the subject’s finger to a model of known size, or even including an automated finger measuring device inside the scanning apparatus that applies a small cuff or similar band around the finger to determine its size prior to scanning. The effect of this measurement on the glucose level determination will be discussed more fully below.

The dashed baseline 502 in FIG. 5 represents a decibel level, at the approximate 2.5 GHz frequency, that highly correlates to normal glucose levels. While the baseline 502 cannot be reliably used as the sole basis for measuring glucose levels, in the absence of comparative pattern matching as disclosed in the ’048 patent, it can be used in conjunction with four other components of the composite signal 500 to reliably determine glucose levels. When referring to each of these components below, a reference to a component being “high” or “low” is in comparison to a median point for that component, and a reference to a component being “positive” or moving “upward” or “negative” or moving “downward” is relative to the scale position of “0” on the decibel vertical scale.

It should also be noted that the composite signal illustrated in FIG. 5, including the peaks, valleys and other signal components, is affected by the shape and strength of the magnetic field, the transmitting and receiving nodes, and numerous other factors, as previously discussed. The exemplary composite signals illustrated in FIGS. 5, 7 and 8 were created using a scanning device similar to that illustrated in FIG. 2. Changes in this device or the use of a differently configured device, such as illustrated in FIGS. 4A-4H, might cause the peaks, valleys and other signal components to shift up or down in frequency or cause other changes that would have to be accounted for in analyzing the resulting composite signal.

The first pattern component is the lowest point 504 (or decibel level) of composite signal 500. This lowest point typically occurs, but does not always occur, at approximate 2.5 GHz. When the lowest point 504 is at the baseline 502, the glucose level of the subject is most likely normal. When the lowest point 504 is above the baseline 502, the glucose level of the subject is most likely high. The further away the lowest

point 504 is from the baseline, in the positive direction, the higher that glucose level is likely to be. Likewise, when the lowest point 504 is below the baseline 502, the glucose level of the subject is most likely low. The further away the lowest point 504 is from the baseline, in the negative direction, the lower that glucose level is likely to be. The terms “most likely” and “likely” are utilized because as previously stated, the baseline 502 alone, or comparison of the lowest point 504 to the baseline 502, only provides a rough estimate of a subject’s glucose level, but it cannot alone be reliably utilized to determine a subject’s glucose level, which is where the other components come in to play.

Sampling points 506A, 506B and 506C, which are sampled at a low frequency (approx. 100 MHz), represent the sample variation pattern component. This component is important because a subject inserting their finger into the scanning apparatus may exert more or less pressure on their finger, or move their finger around, which can cause the composite signal 500 to fluctuate as well, thereby causing the other components to change in some way. However, by sampling the composite signal 500 at each of the specified sampling points 506A, 506B and 506C, it is possible to remove many of the variations caused by finger movement or variation. For example, if the slopes of the lines formed between the three sampling points 506 are high, then the magnitude of the lowest point 504 is adjusted upward toward 0 dB. If the slopes of the lines formed between the three sampling point 506A, 506 B and 506C are low, then the magnitude of the lowest point 504 is adjusted downward.

The next pattern component is the trough 508 in the composite signal 500 formed by the lowest point 504. In its simplest form, the trough component 508 can simply be a measure of the width of the trough at a point just above 0 dB, or the entire area of the trough can be calculated. When utilizing width, if the magnitude of the trough component 508 is high (or wider than the median), then the magnitude of lowest point 504 is adjusted downward. When the magnitude of the trough component 508 is low (or narrower than the median), the magnitude of the lowest point 504 is adjusted upward toward 0 dB. Area is utilized in the same way, with a larger area being used to adjust the lowest point 504 downward, and a smaller area being used to adjust the lowest point 504 upward toward 0 dB.

The last fine-tuning pattern component is a high frequency signal at a specified point 510 at the end of the trough 508. The fine-tuning component is used for just that, to fine-tune the accuracy of detecting the blood glucose level for about 80% of subjects. The fine-tuning component, however, should not always be used because in the remaining 20% of cases, the use of the fine-tuning component could actually lower the accuracy of the measured blood glucose levels of those subjects. Hence, it might be necessary to analyze signal 500 with and without the fine-tuning component to determine if the results of the analysis improve with such use; if they do not, then they are not used. When the fine-tuning component is used, if the magnitude of the specified point 510 is lower than the median, then the magnitude of the lowest point 504 is upward toward 0 dB. When the magnitude of the specified point 510 is higher, the magnitude of the lowest point 504 is moved downward.

Composite spectrogram analysis utilizing different algorithms to detect quantitative relationships or to recognize patterns, similar in some ways to those techniques described above, could also be used to measure many other aspects of a subject’s physical condition or composition, as well as many other characteristics of other types of samples. For example, composite spectrogram analysis could be used to measure or detect the presence of cholesterol (HDL and LDL as well),

red and white blood cells, proteins (including antigens for determining blood type), hormones, steroids, lipids, C-reactive proteins, bacteria, yeast, viruses, pathogens, heavy metals, calcifications, and other biological markers, agents or substances. Once one or more components of a composite signal have been identified as corresponding to any substance that can be found in the blood, tissue or bone of a subject, the presence and levels of that substance can be detected and measured utilizing an embodiment, without invading the subject's body, without having to compare that subject's current results with prior results, and in near real-time due to the speed of the computer aided analysis.

This would enable doctors and emergency medical technicians to perform on the site blood and tissue analysis without further traumatizing the subject and without endangering the doctors or technicians with potentially tainted blood. For example, being able to promptly determine if a patient had consumed alcohol, illegal drugs or even prescription drugs prior to or while transporting that patient to the hospital could prove life-saving in many situations. It would also enable doctors to perform more appropriate diagnosis and treatment of patients without all of the delay created by the current need for blood testing laboratories. It could also take the place of urine analysis testing or blood testing to test drivers, athletes, students, inmates, parolees, employees and countless others for the use of controlled substances, absorption levels of prescription drugs, alcohol and other foreign substances.

When a device in accordance with an embodiment is utilized in a physical facility, the size, construction and operation of the device may be less critical than when utilized in a remote location, such as at the scene of an accident, the side of the road, or at multiple access locations throughout a building. The cost associated with installing bulky machinery at multiple different locations, or the impracticality of utilizing such machinery at a remote location, requires a different solution.

One potential alternative solution is illustrated in FIG. 6, which illustrates a portable scanning device 600 that is capable of capturing raw data from a person or object to be tested at a remote location and wirelessly communicating that raw data to a central server 602. The raw data collected by device 600 could, in turn, be encoded utilizing digital rights management technology, or some similar type of encryption or data rights management technology, so as to further prevent a competitive device from being able to compatibly communicate with the central server 602. The server 602 would then process the raw data according to one or more proprietary analysis programs to produce a diagnostic result for the raw data and wirelessly communicate the diagnostic result back to the device 600. In some applications, the portable device 600 could be very simple and include a few predetermined scanning operations (selected through operation of a physical or electronic button on a touch screen), such as an alcohol test, a methamphetamine test, and one or two other tests, that could be selected by a law enforcement official in the field prior to collecting and communicating the raw data.

In other applications where the user of the remote device wanted a further range of tests, or so as to further reduce the cost of equipment at a remote location or a physical facility and to maintain control over the analysis program, the portable device 600 could be combined with an Internet browser 604 so as to enable the user to operate Internet-enabled applications and to perform other functions. For example, a personal query could be communicated from Internet browser 604 to central server 602 requesting the performance of one of a large number of different tests. The central server 602 would

then communicate with the portable device 600 to request and collect the necessary raw data, which would be communicated back to the central server 602. After processing the raw data, the central server 602 would then communicate the diagnostic results, as well as other data, such as tabulated charts and histories, medical opinions, interpretations and other data, back to the browser 604 for the user. The portable device 600 could be configured to identify itself to the central server 602 for each test to be run or for each data package to be sent, so that the user of the portable device 600 could be charged accordingly, such as on a per test/per download basis, on account, etc. Other forms of identification and payment arrangements could also be possible depending on how much intelligence and how many user interface controls are built into the portable device 600.

While many characteristics of a sample can be detected and measured only using just-in-time analysis based on the recognition of pattern components, to improve the accuracy of the results of some tests, it is desirable to also use some form of pattern matching. For example, biometric identification applications may require a composite spectrogram signal representing a currently tested person to be compared to a database of previously tested persons to positively identify the person being tested or to reject him or her. However, it is neither necessary, nor desirable, to rely on the pattern matching test alone, especially when recognized pattern components can be used to improve the overall analysis.

FIG. 7 is a real-time spectrogram (R) 700 representing a person (P) who was scanned or tested in accordance with an embodiment. As with FIG. 5, the vertical scale represents decibels and the horizontal scale represents frequency, only unlike FIG. 5, in FIG. 7 the frequency scale ranges from 10 MHz to 12 GHz. The composite spectrogram (signal) illustrated in FIG. 7 includes a number of prominent peaks and valleys, the combined position and shape of which, after processing, may be unique to every person.

While changes in a subject's general physical condition, recent dietary consumption, or other factors might alter their composite spectrogram from day to day, week to week, or month to month, possibly causing one person's signal to approximate another person's signal, many of these variances can be filtered out and otherwise accounted for to help reveal each person's unique spectrogram signal shape. For example, it has been observed that some regions of the composite spectrogram change much, while other areas change little, so from scan to scan the raw data can be inconsistent. By applying a filter to a composite spectrogram as part of a recognition algorithm, it is possible to filter out some of the courser variations in the raw data, while minor variations can be accounted for through quantitative analysis of the raw data, thereby enabling the recognition algorithm to focus on the areas of the composite spectrogram that represent unique characteristics of an individual.

FIG. 8 is a stored spectrogram (S) 800 representing the same person P in FIG. 7, but was previously scanned from person P and stored in memory 14 for comparative purposes by CPU 10. If S 800 is known to represent person P, but R 700 is unknown, then it would make sense to compare R 700 to S 800 in order to determine if R 700 also represents person P. However, while a visual or electronic comparison between the two spectrograms 700 and 800 would illustrate some differences, not all of these differences are important because it is known that some components of the spectrograms change frequently, even for the same person, and are not considered reliable identifiers, while other small changes in a signal component are infrequent and might have great significance from an identifying perspective. For example, an embodi-

ment performs the following six comparisons to identify changes that may be of significance: $\alpha\phi$, α_1 , α_2 , $\beta\phi$, β_1 and β_2 , where α represents a change in spectrograms of a single person versus herself/himself, where β represents a change in spectrograms of a single person versus a different person, where ϕ represents a small change, where 1 represents an infrequent change, and where 2 represents no change.

With respect to FIGS. 7 and 8, the primary components or areas of difference between R 700 and S 800 are illustrated on FIG. 8 as the circled areas 802, 804, 806, 808, 810 and 812, although other slight differences might exist between the two signals in other areas. These differences can be quantified using a number of different techniques, such as a filtering algorithm or even the least squares or the sum of the squared error technique, which attempts to find a best fit. Utilizing this technique, if the sum of all variations between the signals at a number of specified test points (selected frequencies along the horizontal line) is less than some predefined number, then the two signals represent the same person. If the sum of those variations is greater than that predefined number, then R 700 represents a different person than S 800.

However, as noted above, some variations between the signals are meaningful and some are not, so an embodiment does not rely upon filtering or the least squares technique alone to determine whether or not R 700 is S 800. As further illustrated in FIG. 8, a horizontal relevancy line 850 has been added below the spectrogram 800. The relevancy line provides an indication of the relevancy of different portions of spectrogram 800 toward the positive or negative identification of a person scanned. The relevancy line 850, as illustrated in FIG. 8, is comprised of three types of regions, forward slash regions 852, blank regions 854, and backward slash regions 856. Only three types of regions are shown in FIG. 8 for purposes of simplifying the drawing, but as many regions as were necessary could be utilized.

Forward slash regions 852 correspond to regions of lower relevance, meaning that there can be a bigger difference between the amplitude in decibels of a point (f_1) at a particular frequency on R 700 within region 852 from the amplitude of a point (f_2) at that same frequency on S 800. For purposes of simplicity, this difference is referred to as Δ , which is the difference between f_1 and f_2 . Hence, the forward slash regions 852 would have a higher threshold level that Δ would have to exceed before a variation between R 700 and S 800 was considered to be meaningful. Blank regions 854 correspond to regions of high relevance and therefore have a low threshold level for Δ . Backward slash regions 856 correspond to regions of medium relevance and therefore have a threshold level for Δ between that of blank regions 854 and forward slash regions 852.

Furthermore, merely exceeding the threshold for Δ within a particular region may or may not be significant depending on the particular frequency level and the region involved. This rule is further illustrated with reference now to FIG. 9, which shows a graph of Δ compared to $f(\Delta)$. The vertical axis $f(\Delta)$ represents values (x) that are assigned to Δ based on Δ 's position on the line 900, which is a graph of all possible Δ s for that particular point on the spectrograms 700 and 800. As shown, the line T on the horizontal line Δ represents the threshold for a point within a region of the spectrograms 700 and 800. When it is known that R 700 and S 800 correspond to the same person, a point 902 on line 900 would be expected to be below the threshold T and would therefore be assigned a low $f(\Delta)$ value, in this case the arbitrarily assigned value of $0.01(x)$. However, if a point 904 is at a much higher point on the line 900, i.e., further past the threshold T, it is assigned a much higher $f(\Delta)$ value, in this case the arbitrarily assigned

value of $3.6(x)$. Since the probability of R 700 belonging to the same person represented by S 800 goes down the further Δ is past the threshold T, the values $f(\Delta)$ increase exponentially along the vertical line $f(\Delta)$ so as to assign higher and higher values to higher Δ values.

As with the sum error squared technique described above, the $f(\Delta)$ valuations for each test point on the spectrograms 700 and 800 can also be summed, with the result effectively being a filtered sum. If the filtered sum for R 700 versus S 800 exceeds a predefined number, then R 700 represents a different person than S 800, and if the filtered sum is below that predefined number, then R 700 and S 800 represent the same person. The predefined number itself is not significant because it depends entirely on the values assigned to $f(\Delta)$, which can be arbitrary. Hence, the numbers for $f(\Delta)$ in FIG. 9 are for illustration purposes only and could be readily changed without departing from the teachings of an embodiment.

An additional technique to be utilized when comparing spectrograms 700 and 800 is illustrated in FIG. 10, which partially depicts a visual pattern matching technique in accordance with an embodiment, referred to herein as a personal identity determinator (PID). FIG. 10 is a PID graph 1000 of B, a baseline spectrogram, versus S 800, where B is the vertical axis 1002 and S is the horizontal axis 1004. The baseline spectrogram B could be formed in a number of different manners, such as forming B from the mean or median of all spectrograms of a large population of people. The points 1006 along B and S represent the sampling points on each spectrogram. While only a limited number of such points 1006 are represented in the PID graph 1000, the total number of points 1006 could be any number. For example, as noted above when discussing the number of sampling points used in a frequency range from about 100 MHz to about 12 GHz, a total of about 3,201 sampling points could be used for both B and S.

However, utilizing that many sampling points in a PID graph will require a significant amount of computing power, memory and processing time, so it is preferable to use between two and three hundred points 1006, representing the approximate number of peaks and valleys in a typical biometric spectrogram for most people. Given the impracticality of representing hundreds of sampling points for both B and S in the PID graph 1000 of FIG. 10, only thirty or so sampling points 1006 are therein illustrated for both B and S. Accordingly, not all of the resulting sampled point squares 1008, representing the crossing points between the same sample points along B and S are illustrated, and only a handful of the sampled point squares 1008 are filled in with a "0" 1010, a "1" 1012 or an "x" 1014, as further described below.

For each sampled point square 1008, a comparison is done between the value of a sampled point 1006 on the spectrogram B 700 and the value of the same sampled point 1006 on the spectrogram S 800. If the value of B for a first sample point is greater than the value of S for the same sample point by more than a threshold level ($B \gg S$), then the corresponding sampled point square 1008 is assigned a "0" value. If the value of B for a first sample point is greater than the value of S for the same sample point by less than a threshold level ($B > S$), then the corresponding sampled point square 1008 is assigned an "x" value. If the value of B for a first sample point is less than the value of S for the same sample point by less than a threshold level ($B < S$), then the corresponding sampled point square 1008 is assigned an "x" value. If the value of B for a first sample point is less than the value of S for the same sample point by more than a threshold level ($B \ll S$), then the corresponding sampled point square 1008 is assigned a "1" value.

Whether a sampled point square **1008** is assigned a “0” **1010** or a “1” **1012** value because B is greater or less than S by more than the threshold is not critical. What is important is that sampled point squares **1008** are thrown out or assigned an “x” **1014** value when B is greater or less than S by less than the threshold. This is important because small differences between the values of B and S could result from noise, thereby making those differences unreliable.

Once all of the sampled point squares **1008** have been filled in, a pattern will emerge of 0’s, 1’s and x’s that is unique to that PID graph **1000**. The pattern of the B versus S PID graph **1000** can then be stored and compared to a real-time created PID graph corresponding to person P, using B versus R, to see how closely the two PID graphs match. These patterns could be compared using any of a number of well known pattern matching techniques. For example, the patterns can be compared row-wise or column-wise, with every exact match adding a point to a total score, with the total score determining the similarity between R and S. The closer the proximity between the patterns of 0’s, 1’s and x’s on the two PID graph, the greater the likelihood that R and S correspond to the same person.

Although three different methods of comparing spectrograms **700** to **800** have been discussed, many additional methods are possible. To some extent, the more comparison methods utilized, such as in combinations of different techniques, the higher the reliability of the biometric identification application. Of course, some comparison methods are more significant than others, so it may be desirable to use a master biometric identification algorithm with each of the comparison methods as its sub-element algorithms to factor in which sub-element algorithms should be utilized in making a biometric identification and what degree of importance those sub-element algorithms should play in the overall identification determination. As illustrated in FIG. **11**, the least square comparison **1102** could be one sub-element to the master algorithm **1100**, while the filtered sum square comparison **1104** could be another sub-element, and the PID **1106** could be the next. As denoted by N **1108**, any number of additional sub-elements could also be utilized in place of or in addition to those illustrated.

As previously noted, an embodiment can be utilized to perform many different tasks or applications. The detection and analysis method to be used in each instance will vary according to the task. For example, scans for human blood components would typically use detection and analysis methods similar to those used to scan for blood sugar levels, but could also use one or more of the methods used for biometric identification, where a known stored signal is compared to a real-time signal. These same types of methods could be used for agricultural inspection, food processing operations, security applications, environmental testing, manufacturing operations and many other applications. Authenticity applications would also be possible, where a security marker is used to mark and subsequently identify a valuable object.

Additional analysis techniques that could be utilized to detect glucose, biometric identification, etc., and which could be used in place of or in addition to N **1108** of FIG. **11**, are further discussed below. In an embodiment, a particular algorithm, referred to herein as Algorithm-J, uses multiple and/or linear regression type calculations to determine, at a given frequency, or at various combinations of frequencies, an instantaneous correlation coefficient, R2 (R-Squared), between the known values of, for example blood glucose, and their corresponding “calculated function”, such as the ratio of differential amplitudes at two or more different frequencies, or the sum of differential amplitudes at two or more different

frequencies, and so on. The procedure used to find “the best known functions” to calculate, is that once you pick one to try and set-up the program to run through the raw data, the CPU **10** finds and reports the regions of value, if any. For example, calculations on data from a “Glucose Tolerance” test, returned 25,140 combinations of the frequency function being calculated that resulted in an R2 value of 0.40 or greater, with the peak R2 value being 0.92. Furthermore, 20 combinations of the frequency function being calculated resulted in an R2 value of 0.84 or greater. Using the latter top 20 frequency functions in a hypothetical ensemble to estimate (simulate) a subject’s blood glucose reading, using an embodiment of a sensor driven by a program using Algorithm-J, provided an R2 value of 0.95.

An embodiment of a method for fine-tuning pattern-recognition-algorithms for use with an embodiment of the non-invasive sensor described above with respect to FIG. **4** is now described. In the analysis of blood glucose levels in live human fingers or other substances, the various algorithms resulting there from, the improved non-invasive blood glucose measurement apparatus enabled thereby, and the subsequent generations of such apparatus enabled there from, provides a quick and inexpensive method of fine-tuning pattern-recognition-algorithms for different embodiments of such scanning apparatuses. A flow chart illustrating how glucose readings from two different finger-stick meters is normally compared to a scanning apparatus scan is shown in FIG. **12**. A flow chart of a Fine Tuning Method A, where a prior subject uses a new sensor or the same sensor, is shown in FIG. **13**.

In the flowchart **1200** of FIG. **12**, a Person A **1202** has their blood glucose analyzed by a first commercial analyzer, step **1204**, and a second commercial analyzer, step **1206**. Step **1208** computes the average of the readings from the first commercial analyzer **1204** and the second commercial analyzer **1206**. The blood glucose of Person A **1202** is also analyzed using the scanning apparatus **1210**, resulting in a spectral data scan, step **1212**. Step **1214** uses a pattern recognition algorithm that works for Person A with the scanning apparatus **1210**. The output of the pattern recognition algorithm is a non-invasive blood glucose reading, step **1216**. Finally, the averaged readings of the commercial analyzers and the reading of the scanning apparatus are checked for agreement, step **1218**. For example, during calibration, if the difference between the commercial analyzer readings and the scanning apparatus readings are greater than an agreement threshold, then the user can be prompted to repeat the process by doing a second sweep with the scanning apparatus. In addition, while the flowchart **1200** shows the use of two blood glucose analyzers, the blood glucose level could be checked by more than two blood glucose analyzers in order to improve the accuracy of the blood glucose measurement.

FIG. **13** shows a flow chart **1300** of a fine tuning method for a pattern recognition algorithm, illustrating the optimization of a scanning apparatus to work with Person A. First, a counter variable Z is set to 1, step **1302**, and then Person A undergoes a glucose tolerance run, step **1304**. This consists of performing a set of N finger-stick readings with a first commercial blood glucose analyzer, step **1306**, and a second commercial blood glucose analyzer, step **1308**, and a corresponding set of N scans performed with the scanning apparatus, step **1310**. The finger-stick readings and scans are done at five to ten minute intervals while Person A’s blood glucose level rises from a fasting level to a high level and then back down to the fasting level. In step **1312**, each first reading from the first commercial analyzer, step **1306**, is averaged with the second reading from the second commercial analyzer, step **1308**.

The pattern recognition algorithm being tuned is used to identify underlying feature set elements F1 through Fk, where k is the total number of underlying feature set elements, step 1314. This results in a set of non-invasive blood glucose readings, step 1316. Step 1318 calculates the correlation coefficient R2 between the finger-stick readings and the non-invasive readings calculated from the pattern recognition algorithm. If it is the first time that the correlation coefficient has been computed, step 1320, then the process continues to perturb the pattern recognition algorithm in order to improve its performance, step 1322.

The perturbation of the pattern recognition algorithm is done by perturbing the value of relationship of underlying feature set element Fx, where x is the xth element in the list of feature elements from one through k. The perturbation of the underlying feature set element Fx is done relative to all the other feature set element of the pattern recognition algorithm. Once the feature set elements used in the pattern recognition algorithm have been perturbed, step 1324 applies the pattern recognition algorithm to the data collected from step 1310, resulting in a new a set of non-invasive blood glucose readings 1316. The new set of non-invasive blood glucose readings are used to calculate the correlation coefficient R2 with respect to the finger-stick readings in order to determine whether the perturbation improved the performance of the pattern recognition algorithm, step 1326.

If the pattern recognition algorithm has been perturbed at least once, then the value of R2 is checked in step 1326 in order to determine whether the correlation coefficient R2 has improved due to the perturbations introduced into the pattern recognition algorithm. If R2 has improved, then the new x feature set element relationship value is saved, step 1328, and the process continues to step 1322 for further perturbations. If the value of R2 did not improve with the introduced perturbations, then step 1330 checks to see whether each element from the underlying feature set elements has been perturbed. Step 1330 performs this check by determining whether the last underlying feature set element to be perturbed is the last element of the set.

If there are still other elements that can be perturbed, then step 1332 restores the xth feature set element relationship value to its value prior to being perturbed, and the value of x is incremented in order to perturb the next element in the set, the perturbation being done in step 1322. If each element from the underlying feature set elements has been perturbed, then step 1334 checks whether R2 has maxed out. If R2 has not maxed out, then the algorithm is perturbed once again in step 1322. At this point, in an embodiment the perturbation in step 1322 restarts with the first element, element 1. In another embodiment, the perturbation in step 1322 restarts with a random element between 1 and k.

In step 1334, if R2 has maxed out, then the counter variable Z is checked to see whether its value is equal to 3. If the value of Z is not equal to 3, then the value of Z is incremented by one in step 1338, and the algorithm is perturbed in step 1322. If the value of Z is equal to 3, then the process stops. At this point, the pattern recognition algorithm has been optimized to work for Person A with the scanning apparatus used in step 1310. By initializing the variable Z to 1 and setting a stopping condition of Z=3, it allows for every element in the feature set of the pattern recognition algorithm to be perturbed two times. A higher value of Z for the stopping condition would allow for further exploration of perturbations of elements of the feature set, with the further exploration possibly allowing for the pattern recognition algorithm to be improved significantly.

In an embodiment, when a pattern recognition algorithm is being optimized for the same Person A but with a new scanning apparatus, then the pattern recognition algorithm that was fine tuned with flow chart 1300 can be used as the starting algorithm to be perturbed and optimized to work with the new scanning apparatus. Other alternative methods that can be used to fine-tune the performance of the pattern recognition algorithm include hill climbers and genetic algorithms.

The fine-tuning and determination methods both utilize spectral data sets derived from scans of fingers. One problem when working with an individual is repeatability of finger placement in the scanning apparatus and finger pressure on the electrodes or guide pieces in the sensor. Small errors in finger placement of the same finger from time to time introduce errors in the corresponding spectral data set. Portions of the spectral data relating to an individual can be utilized in specific comparative calculations to determine possible finger placement error. When the apparent placement error is small, the scanning apparatus announces or otherwise signals to the person, that the finger placement is excellent, or if there is a larger placement error, the person can be told that the placement is not as good as last time, or un-acceptable, or to please try again. Only when the finger placement is found to be “excellent”, does the non-invasive blood glucose algorithm begin scanning spectral data to measure the person’s blood glucose level. Then, by accumulating and averaging the successive excellent scans over time, and comparing each new spectral data set to the accumulated average, the individual can be trained how to place their finger so as to reduce finger placement error going forward. Reduction of finger placement error will improve the accuracy of the non-invasive blood glucose measurement.

An embodiment is directed to a method for analyzing spectral data sets. The scanning apparatuses disclosed herein are capable of measuring the real and imaginary components of transmitted RF signals and the real and imaginary components of reflected RF signals. The real components represent the purely resistive properties of the sample (and associated scanning apparatus parts) placed within the scanning apparatuses, while the imaginary component represents the capacitive and inductive properties of the sample (and associated scanning apparatus parts). The computer 16 can also work with the transmitter 18 and receiver 20 to measure phase and power, which are derived from the real and imaginary components (also called the “raw components”) of the reflected and transmitted signals. For example, total log magnitude power can be derived as follows from the real and imaginary components (using log to the base 10):

$$\text{Power} = 20 \times \log(\sqrt{\text{Real}^2 + \text{Imaginary}^2})$$

wherein “Real” is the real component of either the transmitted RF signal or the reflected RF signal and “Imaginary” is the imaginary component of either the transmitted RF signal or the reflected RF signal, all signals measured in root mean squared (RMS) volts, such that total transmitted power is derived from the real and imaginary components of the transmitted RF signal.

Referring back to FIG. 1, the transmitted RF signal is best understood as that portion of the transmitted signal that is received by the receiver node 24 after having passed through or around the sample (referred to herein as S21—which refers to signals received at port 2 of the receiver 20 from port 1 of the transmitter 18), while the reflected signal (referred to herein as S11—which refers to signals received at port 1 of the transmitter 18 from port 1 of the transmitter 18) is comprised of two portions, the portion that is reflected from the sample back into the transmitter node 22 and to the receiver

20, and the portion of the transmitted signal that is never actually transmitted by the transmission node 22 because of inefficiencies in the circuitry and is reflected into the receiver 20 from the transmission node 22.

The embodiment first requires a known sample to be registered with the computer 16 based on a variety of known conditions, so an unknown sample can subsequently be analyzed to determine its unknown conditions. For example, a human subject may place a finger within the scanning apparatus to have their unknown glucose level determined by the computer 16, but this first requires the same human to have the same finger tested by the scanning apparatus when the human's glucose levels are known, and preferably at different glucose levels. Hence, the human (referred to as a patient herein) would be required to test a finger with a traditional glucose meter (a finger prick device) after fasting and then immediately place an adjacent finger into the sensor to be scanned or tested by the sensor, the adjacent finger is used to keep from getting blood on the sensor surfaces from the pricked finger. The patient would then be required to drink a highly sweetened liquid (such as Glucola), which causes the patient's glucose level to rise. As the patient's glucose level rises, the patient's finger would be tested with a glucose meter and scanned by the sensor, and then as the patient's glucose level begins to return to a more normal level, the patient's finger would be tested with the glucose meter and scanning apparatus to develop a complete set of different glucose levels (high, low and normal). Since the variance between different glucose meters can be significant, it may be desirable to test each patient with at least two different glucose meters and average the results, as illustrated in FIG. 12.

When the patient's finger is placed in the scanning apparatus, the transmitter 18 transmits a series of RF signals starting at a base frequency and stepping up numerous times to higher frequencies until reaching a maximum frequency. Numerous different frequency ranges can be utilized. An embodiment uses a frequency range between about 0.3 MHz and about 20.1 GHz. The number of steps taken within the frequency range can also vary significantly. An embodiment uses an equal number of about 16,000 sampling points over the frequency range, but significantly smaller sets of sampling points could be used, equally spaced through the frequency range, or specific frequencies could be selected for a specific type of test. The total transmitted power signal received by the receiver 20 at each of the 16,000 or so sampling points is then recorded and processed.

The initial step of the process in this sampling embodiment, referred to herein as the "L-21 algorithm," involves taking the total transmitted power signal recorded for the first sample point and dividing it by the total transmitted power signal recorded for each of the remaining samples points (i.e., 2/1, 3/1, 4/1, 5/1, etc.), then taking the total transmitted power signal recorded for the second sample point and dividing it by the total transmitted power signal recorded for each of the remaining samples points (i.e., 3/2, 4/2, 5/2, 6/2, etc.), and repeating this process until reaching 16,000/15,999. Alternatively, each sample point could be the numerator and the remaining sample points the denominator (i.e., 1/2, 1/3, 1/4, 1/5, etc.), or sample points could be grouped in sets of sample points, which are averaged together and then divided by the next set of averaged sample points, etc. The key in each case is to develop a set of ratios that can be compared to other ratios for each scan performed by the sensor.

In this L-21 algorithm embodiment, the total transmitted power signals recorded for the 16,000 sample points are grouped into clusters or sets of five sample points that are then averaged. Dividing the 16,000 sample points into clusters or

sets of five points would result in 3,200 ($16,000/5=3,200$) clusters or sets. The first cluster is divided into the second cluster, and then the first cluster is divided into the third cluster, etc., up until the first cluster is divided into cluster 3,200. This process then continues with the second cluster divided into the third cluster, the second cluster divided into the fourth cluster, etc. This is repeated until cluster 3199 is divided into cluster 3,200, to develop the complete set of desired ratios. The number of sample points included in a cluster could be a number other than five. Five sample points is used to explain this embodiment since this number of sample points has yielded good results in initial testing, however, additional cluster sizes may yield better results. Generally, clusters offer an advantage over individual sample points because the clusters are less sensitive to frequency shifts that can be introduced by the sample, variations in scanning apparatuses and other external factors.

Once a number of scans of a patient have been performed (the patient having different known glucose levels during each scan) and complete spectral data sets of desired ratios have been developed for each scan, a ratio matrix of the clusters is developed. FIG. 14 illustrates a ratio matrix of the clusters from a total of twelve glucose levels scanned for a patient. A number of different glucose levels could have been used, such as fewer glucose levels, or a first minimum number of glucose levels when a number of registered patients in the database is below a first registration count, and a second minimum number of glucose levels when the number of registered patients is greater than or equal to the first registration count. The minimum number of glucose levels to be used varies with respect to the number of registered patients and other factors. For instance, the minimum number of glucose levels can be set according to an accuracy level associated with the determination of an unknown sample. If a minimum of six glucose levels is used, and this yields a determination accuracy below the desired accuracy, then the number of glucose levels should be increased accordingly.

It is generally believed that scanning a high number of glucose levels, such as twelve, would yield better results, especially if each patient's glucose levels were scanned under different conditions, such as different atmospheric pressures, higher and lower levels of humidity, higher and lower levels of ambient temperatures, higher and lower levels of skin temperatures, etc. In the absence of being able to change glucose levels as well as other environmental and patient conditions, it may be necessary to factor out the environment and patient conditions, which can be done through application of one or more correction factors.

An embodiment of a correction factor application uses different measured scan parameters to compensate for changes to analytes other than glucose that occur in response to the patient drinking the sweetened liquid, and other variables such as the patient's temperature, the patient's hematocrit levels, the patient's blood pressure level, etc., which can be measured by means other than the commercial blood glucose analyzers 1204 and 1206 shown in FIG. 12. For example, instead of correlating power as described above, phase and other scan parameter correlations can be established for the variables other than glucose, and their corresponding correlation coefficients used to identify frequencies to be avoided when establishing glucose concentration. Also, in addition to single variable linear regression calculations described below, multiple linear regression calculations can be used to identify frequencies to be avoided in the presence of multiple variables.

Another correction factor embodiment measures a substance of interest using, say, power or impedance, at a scan

frequency sensitive to the substance and one or more measurements of power or impedance at scan frequencies not sensitive to the substance, but sensitive to additional confounding substances known to be present in the patient or the sample. The changes in power or impedance due to the additional substances can be subtracted from the sensitive frequency measurements of the substance of interest. The remaining change in power or impedance gives a measure of concentration of the substance in the patient or sample.

The next step in the L-21 algorithm process is to take each row of ratios and the results from the glucose meter and perform a least squares analysis (such as through utilization of the LINEST function in MICROSOFT EXCEL® software, manufactured by MICROSOFT®) to determine how many rows of ratios within the ratio matrix of FIG. 14 consistently correlate to glucose levels. In this context, the term “consistently correlate” means that the R² value for the ratios within a row is 1 or close to 1. If the R² value for the ratios within the row is zero or close to zero, then the row of ratios does not correlate.

The L-21 algorithm embodiment uses the least squares method to calculate a straight line that best fits the data. The accuracy of the line calculated depends on the degree of scatter in the data. The more linear the data, the more accurate the result of the least square analysis. When you have only one independent x-variable, the calculations for the slope of the line (m) and the y-intercept (b) are based on the following formulas:

$$m = \frac{\sum (x - \bar{x})(y - \bar{y})}{\sum (x - \bar{x})^2}$$

$$b = \bar{y} - m\bar{x}$$

where \bar{x} (x-bar) and \bar{y} (y-bar) are sample means. The least squares method can also be used to calculate a polynomial that best fits the data, such as a quadratic, cubic, or other higher order polynomial function. If the data cannot be “fitted” with a straight line function, then a polynomial function can be used.

For each ratio within a row having an R² value of 0.5 or higher, the R² value, slope and y-intercept are added to a preliminary registration table, as illustrated in FIG. 15. Once all of the rows within the ratio matrix of FIG. 14 have been evaluated and the table of FIG. 15 has been completely populated, the table is sorted to determine the 21 ratios with the highest R² values. These 21 ratios and each corresponding R² value, slope and y-intercept become the user’s or patient’s registration table. As with other numbers noted herein, the number of 21 ratios may not ultimately yield the best result for each patient or all patients. Hence, another number of ratios may be better, but for the purpose of describing the L-21 algorithm embodiment, the 21 ratios with the highest R² values seem to offer the best predictability of other numbers tried. An embodiment can use less than 21 ratios or more than 21 ratios. Moreover, it may turn out that picking ratios with the highest R² values excludes certain ratios that include important information for other reasons. For example, it may turn out that knowing which ratios have R² values closest to zero can be important for other reasons, such as determining the presence and quantity of other substances in the sample, such as a protein or another molecule aside from glucose.

Once the registration table has been completed for a patient, it can be used to predicatively determine the patient’s glucose level when it is not also known through use of a

glucose meter. Hence, a scan of the patient would be performed and analyzed in view of the registration table to determine the patient’s glucose level at the time of the scan. The formula used to predict glucose levels is as follows:

$$P_1 = (R_m) \text{Slope} + \text{Intercept}$$

where P₁ is a predicted glucose level and R_m is the measured ratio that corresponds to the slope and y-intercept. This prediction is then performed for each of the 21 ratios in the patient’s registration table and the result of the 21 predictions is averaged to determine the patient’s glucose level at the time of the scan.

A biometric identification embodiment referred to herein as the True Call algorithm utilizes data collected from spectral data sets and executes a calculation at each sample frequency that asks: Is this a spectra for a specific person, such as “Harra”? If the answer comes back “Harra”, that frequency is tagged as “True Call” for Harra, and the next frequency is tested. This procedure was repeated for each of a number of other people in a data file, and out of the 3,200 frequencies, 988 frequencies correctly identified one of the people in the data file at least half the time. Even if only 20 frequencies correctly identified a person half the time, the chance that someone would be mis-identified would be 0.5²⁰, which equals 0.00000095.

The True-Call algorithm approach can also be used to identify something by taking a new spectra (spectral data set) and comparing it against a “Library” of known substances, such as wines, liquids, known glucose/distilled water solutions in sealed test tubes, etc. The True-Call algorithm consists of an enrollment phase and an identification phase.

FIG. 16 shows a flowchart 1600 describing the enrollment process of the True-Call method. Enrollment begins by inserting the item of interest, the sample, such as a finger, into a scanning apparatus, step 1602, and capturing either one or more spectra, step 1604 as further described below. If multiple spectra are captured, the multiple spectra can be averaged in order to improve the signal to noise ratio. Multiple scans for each item are obtained by removing and reinserting the sample into the scanning apparatus for each scan. Such a procedure can be necessary to capture effects of sample placement error, sample rotational error, among other types of errors. As noted above, the term “spectra” refers to spectral data sets of pairs of frequency and corresponding signal amplitude measurements. The signal amplitude can be for transmitted, reflected, total net power, or a related component normalized or not. The types of item to be scanned can include many different items, including wines, other liquids, objects, etc. Multiple enrollment spectra are taken under normal environmental or application conditions and then processed to make sure data is qualified, error free, self consistent, etc.

Step 1604 performs a scan sweep of the item of interest to collect the spectra data. The data collected is stored in a database or in an alternative storage system, step 1606. Step 1608 checks to see whether enough scans have been collected. If additional scans are needed, then the user is prompted to insert the item of interest into the scanning apparatus again in step 1602. This number can depend on the nature of the sample, with biological samples requiring more scans due to variations in the sample with each scan (fingers inserted at different depths, fingers turned, fingers sweaty and then dry, fingers applying more pressure inside the scanning apparatus one time and less the next, etc.). After enough scans have been collected, the data is inspected for gross errors, step 1610, by calculating the average, standard deviation, and sum of standard deviations of the spectral data scans. This proce-

dures allows for the identification of erroneous or questionable spectra taken at the wrong moment, such as when the item was moving instead of being at rest. If the data is erroneous or questionable, step **1612**, then the enrollment process is restarted, step **1614**.

If the data is error free, qualified, and self consistent, then step **1616** finds predictive frequencies for the item of interest. For every given frequency, the frequency is polled by asking whether the spectra is a specific instance of an item. For example, if the True Call algorithm is being used to identify a user X, each frequency would be polled by asking whether the spectra at the given frequency is a spectra for user X. If the response was user X, then that frequency is tagged using a number, a Boolean, a string, or some other type of identifier. The polling is done by taking each scanned spectra K from the multiple scanned spectra, and then identifying the average spectra value along each frequency J which most closely matches the value at frequency J of the scanned spectra K. If the average spectra value which most closely matches is the average spectra value of the current item of interest being enrolled, then the frequency J is tagged as correctly identifying the item of interest.

The spectra for each item can be stored in a database or stored in a simple text file as raw text or organized using a markup language such as XML. For each item, the average of the enrollment spectra can also be stored in some fashion. The average value of the enrollment spectra can be updated by conducting a second enrollment and capturing a second set of enrollment spectra. The raw data from the first enrollment can also be combined with the raw data from the second enrollment, with the average of the first and the second enrollments combined being computed. The first enrollment and the second enrollment can also be combined, and the combined enrollment spectra filtered in various ways. For example, outliers can be discarded, or spectra more than one standard deviation from the mean can be discarded, etc. The user may also choose to manually discard spectra enrollment if the identification process performs below a desired accuracy. For example, during a biometric application, a user may have positioned the wrong finger in the scanning apparatus during enrollment, or the user may have positioned the finger consistently in the wrong orientation, making it appear as if the enrollment spectra were correct when it was not. In this case, if the user was not identified properly after several tries, then the user could clear the existing enrollment spectra and conduct another enrollment.

For each item in the database or storage, the average of multiple enrollment spectra differential amplitudes are used to identify the item. For identification, an item is placed in the scanning apparatus and spectra over a range of frequencies or over specific frequency values are captured. The captured frequencies of the unknown item are compared against the database. For each frequency J in the captured frequencies, the frequency J is used as the search index to obtain average spectra values, obtained during enrollment, that match the frequency J. By checking whether any of the entries along each frequency match the captured spectra value associated with frequency J. If an exact match is not found for the spectra value at frequency J in the entries in the database for frequency J, then the average spectra that is closest in value to spectra value is marked as the matching spectra. A counter is incremented for the matching average spectra. After all frequencies in the table or database have been checked, a first candidate associated with the highest matching count is identified as the correct candidate. If a count difference between the first candidate with the highest matching count and a second candidate with the second highest matching count is

X, then an estimate of probability of misidentification of the first candidate is 0.5^X . For example, if the first candidate had a matching count of 1,000, and the second candidate had a matching count of 800, then the probability of misidentification of the first candidate would be approximately $0.5^{(1,000-800)}$ which is equal to $6.22e-61$, which is an astronomically low probability. Even if the count difference had been only 10, the probability of misidentification of the first candidate would have been approximately 0.00098. This makes the True-Call algorithm a very powerful identification tool.

FIG. 17 illustrates a table **1700** used for an embodiment of the True-Call algorithm. Each column **1708** contains the average spectra differential amplitudes collected during enrollment for a user. Each row **1704** contains the transmitted power at various frequencies, starting at frequency F1 through frequency FN. The table may also be structured in other ways, or additional tables may be used to store additional information. For example, the actual raw data readings may be stored in a separate table, with table **1700** only containing the average values from the separate table. During the identification process further described below, the True-Call algorithm iterates over every row **1704** in table **1700**, identifying the column entry along each frequency which most closely matches the unknown spectra value at each frequency. For example, row **1704** for frequency F1 would be searched to identify the column **1702** which most closely matches the unknown spectra value at frequency F1.

In an embodiment, the N spectra values greater than and closest to the match found and the N spectra values less than and closest to the match found can also be counted, instead of only counting the single most approximate match. For example, if the N was 1, then the match found, and the next spectra value greater than the match found but closest to the match found, and the next spectra value less than the match found but closest to the match found, would also be counted. In FIG. 17 if **1708** was the match found for the current unknown spectra value at frequency F1 and N was set to 1, then **1710** and **1712** would also be counted. For A2 the N=1 neighbors would be A1 and A3, for A1 the N=1 neighbors would be only A2. Sorting can be used to organize spectra values as desired, but is not required to identify the immediate value neighbors to the match found. The immediate value neighbors can also be identified by iterating one or more times over the unsorted spectra values for a given frequency.

In an embodiment, neighbors across frequencies are counted as well. Instead of finding the N neighbor values within a frequency (a row **1704**), the M frequency neighbors located on the same column **1702** as the match found would be counted. If a match was found in the third column of the frequency F1 row and M was set to 1, then the frequency neighbor would be the entry on the third column of the frequency F2 row. If the match was found on the third column of the frequency F2 row, then the M=1 neighbors would be the third column entries on frequency rows F1 and F3. Obviously, if this embodiment is utilized, the spectra values would need to be sorted in advance before attempting to count entries in other columns.

FIG. 18 shows a flow chart **1800** of the identification phase. Step **1802** prompts the user to insert an unknown sample into the scanning apparatus. Step **1804** performs a scan or sweep, and step **1806** checks whether enough sweeps have been collected. If additional sweeps are needed then the user is prompted to insert the unknown sample into the scanning apparatus in step **1802**. The data collected is inspected for gross errors in step **1808** by computing the average, standard deviation, and sum of standard deviations of the spectra data sets. This procedure allows for the identification of erroneous

or questionable spectra taken at the wrong moment, such as when the unknown sample was moving instead of being at rest. If the data is erroneous, step 1810, then the identification process is restarted, 1812. If the data is error free, then step 1814 finds spectra frequency matches in the database. This consists of taking the average of the values along each frequency of the scanned spectra and finding the closest matches along each frequency in the database, as described above.

Step 1816 counts the number of hits or matches for each candidate in the database. Step 1818 identifies the candidate with the greatest hit count, and step 1820 computes the probability of the candidate having been identified incorrectly (incorrect probability). If the incorrect probability is less than an unknown candidate threshold T1, step 1822, then the user is notified that the unknown sample could not be identified, step 1824. If the incorrect probability is greater than or equal to the unknown candidate threshold T1, but still less than a confidence threshold T2, step 1826, then the suspected candidate identified is confirmed with a second unique identification algorithm, step 1828, further disclosed herein. If the incorrect probability is greater than or equal to the confidence threshold T2, step 1826, then the user is notified of a successful identification and the candidate ID is presented to the user, step 1830.

As discussed above, if the count difference is less than a count difference threshold, meaning that the confidence threshold was not met, then a second unique frequency algorithm is used to confirm the suspected candidate selected. The second algorithm ranks the top few likely candidates selected, say G3, G1, and G4, in order to confirm the candidate selected by using a set of frequency values that are more or less unique to each specific candidate's spectra. When the enrollment scans are completed, the True Call frequencies found to have successfully distinguished the enrollee as distinct from other frequencies for other people enrolled in the database are put into a frequency table for the enrollee. Later, any frequencies that tend to be common (e.g., shared by half of the other people in the database) are removed from the enrollee's set of frequencies in the unique frequencies table.

The unknown spectra, as mentioned above, are interpreted for each of the top few likely candidates at only those unique frequencies in the unique frequencies table corresponding to the top few likely candidates. If the unknown spectra are for one of the likely candidates, say G3, a comparison of the unknown spectra amplitudes with the amplitudes in G3's enrollment spectra at each of G3's unique frequencies will show relatively small differences. This comparison can be performed by calculating the square of the difference between the unknown spectra amplitudes and the amplitudes in G3's enrollment spectra at each unique frequency and then calculating the sum of these squared differences. Since the amplitudes vary considerably across the spectra, it is best to normalize the sum of squared differences by dividing by the average of the absolute amplitudes at all frequencies scanned in the spectra, also squared (see formula below). Also, since each likely candidate may have a different number of unique frequencies, it is best to multiply by the ratio of the number of frequencies scanned in the spectra divided by the number of unique frequencies for candidate G3. The formula for this figure of merit calculation for likely candidate G3 is:

Figure of Merit for G3=(sum of (differences at G3's unique frequencies between unknown spectra amplitudes and G3's enrollment spectra amplitudes)²×(number of frequencies scanned in spectra)/((average of absolute amplitude of G3's enrollment spectra)²×number of G3's unique frequencies).

This calculation is then repeated for likely candidates G1 and G4, and if the candidate with the smallest figure of merit passes a threshold test, that candidate is confirmed.

For example, a new unknown spectra is identified as being user G3 with the True Call algorithm, but G1 and G4 are the next most likely choices. The second unique frequency algorithm verifies that the new unknown spectra belong to user G3 by comparing the figures of merit described above and selecting the candidate with the lowest figure of merit. If the differences between the figures of merit for user G3 and users G1 and G4 exceed a threshold value, or exceed a number of standard deviations, then the identity is confirmed.

An embodiment consists of a biometric identification algorithm, where one or more independent algorithms separately analyze a biometric scan (a scan performed of a person using a scanning apparatus), and each makes an identification determination. The identification determination from each algorithm counts as a vote for a potential identity candidate, with the potential identity candidate with the most votes being the actual identity identification. Alternatively, the identification determination from the one or more independent algorithms can be combined in other ways, such as by applying different weights to the contributions by each algorithm. The one or more independent algorithms can also be used in combination, such as by applying them sequentially, with the output of a first algorithm feeding into the input of a second algorithm. The first algorithm can reduce the identity of a user or a sample to a set of candidates. The set of candidates can be input into the second algorithm, which further reduces the set of candidates to a second set of candidates. The second set of candidates can subsequently be input into a third algorithm, with the process ending when the output of one of the algorithms is a single candidate or if the set of candidates cannot be further reduced after passing through the various algorithms.

In an embodiment, a minimum identification threshold can be used to discard majority scores or votes if the total score or votes for a potential candidate are below the minimum identification threshold. If an algorithm received the majority weighted score of 55, but a minimum identification threshold was set at 60, then the result would be an unknown.

The weights assigned to the result of the various algorithms can be set based on empirical observations. For example, if it is known that an algorithm A is particularly robust to noise, then a higher weight can be assigned to the result of algorithm A. Likewise, an algorithm that does not have robust performance can be used as a supplementary algorithm and assigned a lower score, providing support to more robust algorithms. Alternatively, the choice of algorithms used and the corresponding weights can be dynamically varied depending on one or more conditions. These conditions can include the current temperature of the sample, current ambient temperature, and the amount of pressure applied by the sample during measurement. If algorithm B is known to perform well under certain conditions, such as when the sample's temperature is above or below a certain point, or when using a certain frequency group, then it can be assigned a higher weight when those conditions are identified. Other conditions can depend on transient conditions, such as the time of day. For example, if an embodiment is being used for biometric identification of users, then the algorithms used or the choice of weights used for each algorithm can be adjusted during and after lunch times. If it is expected that users will consume food during lunch times and with this likely to raise the average glucose level of users, then this can be taken into consideration.

In an embodiment of the biometric identification algorithm, a user goes through a registration process with the goal of building a unique identity profile (identity profile) for the user, the unique identity profile subsequently stored in a database or other storage system. The identification is not restricted to users, but can also be applied to liquids or other solid substances. From here on, the term “sample” will be used to refer to either a user or other material. The biometric identification of the sample is done on a determination process.

A sweep consists of placing the patient’s finger, or some other sample of interest, in the scanning apparatus, wherein the transmitter transmits a series of RF signals starting at a base frequency and stepping up numerous times to higher frequencies until reaching a maximum frequency, or only scans at a number of predetermined frequencies. Numerous different frequency ranges can be utilized. An embodiment uses a frequency range between about 10 MHz and about 12 GHz. The number of steps taken within the frequency range can also vary significantly. An embodiment uses an equal number of about 3,200 sampling points. The total transmitted power signal received by the receiver at each of the 3,200 sampling points is then recorded and processed.

During the registration process a sample of interest is scanned multiple times using an embodiment of the scanning apparatus. Each scan is referred to as a sweep. In the case of a user, the user’s finger can be scanned. In the case of a liquid, a small amount of the liquid can be placed inside a test tube or some other container which can be fitted inside the scanning apparatus. The flow through sensor can also be used for the registration process. An embodiment of the unique identity profile consists of recorded measurements by the scanning apparatus, and the result of various analyses conducted on the recorded measurements. A subset of the information stored for each user in the database is used to subsequently determine the identity of a user during a determination process.

In an embodiment, a single sweep is used to build the identity profile for the user, such identity profile subsequently being used to verify the identity of the user. A higher number of sweeps increases the accuracy of the system, as the numerous sweeps allow for normal variations in the user to be recorded and for noise in the data, whether due to improper sample positioning or too much pressure applied by the sample, to be filtered out. In an embodiment, the number of sweeps is five or more, although fewer sweeps could be used.

The identification of a sample is not restricted to users. The identification can be used to identify properties of a sample. For example, a sample can consist of a fluid in a tube inserted into the scanning apparatus. A profile of the fluid can be built on the database and subsequently used for identifying fluids with similar properties. As previously discussed herein, the authenticity of liquids and other objects, such as money, bonds, antiques, documents, etc. can be verified.

After a number of sweeps have been completed, the second step extracts raw data associated with a number of frequency clusters. In an embodiment, a frequency cluster consists of one or more frequency values picked manually through observation of the spectra for a number of people based on two criteria: (1) the variation among the different people needs to be significantly large; and (2) the variation for the same person at difference scans needs to be relatively small. The frequency values picked for the clusters may be dependent on the sample and the intended application. For a biometric identification application where the sample is a finger, a total of about 16 frequency clusters are utilized that each fall within a spectrum between about 2.0 GHz and about 6.3 GHz. The frequency points in each cluster are contiguous frequen-

cies that were generated by the transmitter 18. Although the clusters are manually selected in this embodiment, they could be determined by the computer 16 by seeking the largest coefficient of variation for different people with a minimized coefficient of variation for the same person.

Clusters are utilized to achieve relative stability of measurement components. Once the clusters are selected, the average or mean values of the amplitude data within each cluster is calculated and used as a single “point”. The calculated means or averages for a cluster from the 16 clusters for each sweep include average values of the amplitude measurements for the cluster, but can also include average slopes for the cluster, average curvature for the cluster, and the log magnitude sum for the cluster. Hence, each cluster becomes a single point consisting of a set of points and associated data.

The fourth step calculates statistics for each cluster over all the sweeps. For example, if there were a total of five sweeps, each sweep with 16 clusters, then the statistics would look at the first cluster from the first sweep, the first cluster from the second sweep, the first cluster from the third sweep, the first cluster from the fourth sweep, and the first cluster from the fifth sweep, etc., continuing with the other 15 clusters. The statistics include calculating the average and the standard deviation for the measurements, the average and the standard deviation for the slopes, and the average and the standard deviation for the curvatures.

The fifth step sorts the cluster order based on the average sum of log magnitude over all the sweeps. The maximum four cluster numbers and the minimum four cluster numbers are determined based on the sorted cluster order. The sixth step calculates the sum of difference squared for each sweep using cluster averages. The sums include the sum for measurements, the sum for slopes, and the sum for curvatures.

The seventh step calculates statistics for the sums of difference squared. The statistics include the average sum of difference squared for measurements, the average sum of difference squared for slopes, the average sum of difference squared for curvatures, the standard deviation of the sum of difference squared for measurements, the standard deviation for the sum of difference squared for slopes, the standard deviation of the sum of difference squared for curvatures.

The final step sets the tolerances. The measurement difference squared tolerance is set to four times the standard deviation of the measurement difference squared. The slope difference squared tolerance is set to four times the standard deviation of the slope difference squared. The curvature difference squared tolerance is set to four times the standard deviation of the curvature difference squared.

In an embodiment of a biometric identification application utilizing the identity profiles built above and the scanning apparatuses described herein, a set of fields corresponding to measurements and statistics computed for a person can be stored in a database. The information stored in the database for each person can include the average of difference squared for measurements, measurement of difference squared tolerance, average sum of difference squared for slopes, slope difference squared tolerance, average sum of difference squared for curvatures, curvature difference squared tolerance, the M maximum sum of log magnitude frequency clusters, and the N minimum sum of log magnitude frequency clusters. In addition, for each user, a set of additional reserved parameters may also be saved on the database for each user. For example, one of the additional reserved parameters can store the standard deviation of the sum of difference squared for measurements.

An embodiment of the determination process begins by performing a scan sweep. Raw data is collected at the N

frequency clusters, where N may be 16 or an alternative number of frequency clusters. Finally, average values are calculated for the clusters. The average values for each cluster include the average values of measurements, the average slopes, and the average curvature. Other statistics computed for each cluster include calculating the log magnitude sum for each cluster. Sorting the cluster order for the sum of log magnitude. The maximum four cluster numbers and the minimum four cluster numbers are determined based on the sorted cluster order.

For determining the identity of a scanned individual, the first step consists of calculating the sum of difference squared against people in the database. The sum of difference squared can be computed for measurements, for slope, for curvature, or for some other property. The second step finds a set of candidates in the database that have the smallest sums of difference squared.

The third step checks the tolerance of the sum of difference squared for each candidate in the set of candidates. Overlap among the set of candidates with the lowest sum of difference squared are determined by checking whether intervals of two or more candidates overlap, with an interval starting at a minimum overlap point and ending at a maximum overlap point. The low end of the interval for a candidate is computed by subtracting the tolerance value from the sum of difference squared. The high end of the interval for a candidate is computed by adding the tolerance value to the sum of difference squared.

If there is no overlap between any intervals, then a determination is made using a determination candidate from the set of candidates with the lowest sum of difference squared. The measured sum of difference squared is compared against the average sum of difference squared for the determination candidate. If the sum of difference squared is within the tolerance interval, then the determination candidate is identified as the correct identity and the determination process completes. If the sum of the difference squared is outside of the tolerance interval, then the identity cannot be determined and is unknown, and the determination process completes.

If there is overlap among the set of candidates with the lowest sum of difference squared, then the database is checked for each candidate in the set of candidates. In an embodiment, only the candidates in the set of candidates that have any overlap are checked in the database. Alternatively, if there is overlap between two candidates in the set of candidates, but the two candidates are not the candidates with the lowest sum of difference squared among the set of candidates, then only the candidate with the minimum sum of difference squared is checked in the database. The step of checking in the database consists of comparing the sum of the measured sum of difference squared with the average sum for the candidates in the set of candidates. If the sample sum of difference squared is within tolerance of the average sum of difference squared for the candidates in the set of candidates, then all candidates in the set of candidates are possible identification candidates. If the sample sum of difference squared is outside of the tolerance, then the sample is unknown and a determination cannot be made.

A candidate in the database is compared against a sample during determination by first checking the cluster numbers with the maximum sum of log magnitude. Second, the cluster numbers are checked with the minimum sum of log magnitude. In an embodiment, N maximum sum of log magnitude cluster numbers and M minimum sum of log magnitude cluster numbers would be identified. For example, if there are a total of 16 frequency clusters, with N equal to 4 and M equal to 4, then the four maximum sum of log magnitude cluster

numbers and the four minimum sum of log magnitude are identified. In an embodiment, N is not equal to M. Sorting a sequence of numbers and identifying the maximum N elements and the minimum M elements of the sorted, or unsorted, sequence is well known in the art and need not be further described herein.

The N maximum sum of log magnitude clusters and the M minimum sum of log magnitude clusters of a possible candidate in the database are compared against the unknown sample. A set of points can be awarded based on a set of matching criteria. These matching criteria can include the N maximum sum of log magnitude cluster numbers (NLOGMAX) matching in order, matching out of order, or not matching at all, and similarly for the M minimum sum of log magnitude cluster numbers (MLOGMIN). A positive match consists of a cluster number being common in the possible candidate and in the unknown sample.

If there are a total of 16 frequency clusters with four entries in NLOGMAX and four entries in MLOGMIN, then the entries in NLOGMAX can be "15 03 08 12" and the entries in MLOGMIN can be "02 11 14 05", with "15" being the cluster number with the highest sum of log magnitude number out of all 16 frequency clusters, and where 12 is the smallest of the four maximum sum of magnitude cluster numbers. The cluster number "02" in MLOGMIN is the smallest sum of log magnitude number out of all 16 frequency clusters, and "05" is the highest of the four minimum sums of magnitude cluster numbers. If the matching rules include taking into consideration the order of the elements in the NLOGMAX and MLOGMIN, then the elements in NLOGMAX and MLOGMIN can be sorted, either in increasing or decreasing order. However, the key is that the sorting order matches the sorting order used with the unknown sample, since MLOGMIN of a candidate in the database is sorted in increasing order, and the MLOGMIN of the unknown sample is sorted in decreasing order, then this would yield erroneous order matching.

In an embodiment, matching begins by iterating over NLOGMAX of either the unknown sample or a candidate. The first element from NLOGMAX in the unknown sample is searched for in NLOGMAX of the candidate. If the first element is found in both NLOGMAX of the unknown sample and of the candidate, then a certain amount of points can be awarded. If the positions are the same, in this case both being the first element of the respective NLOGMAX, then additional points can be awarded. For example, in FIG. 19, the entry "15" at the top of column 1902 out of columns 1900 and 1902 is a match out of order, because the entry "15" is in the first position in column 1902, but it is in the second position in column 1904 for the candidate row 1910. Whereas, the entry "12" in column 1902 is a match in order because it is also in the last position in column 1904 for the candidate row 1910. The rest of the entries are not matches. In unknown sample row 1908, column 1906 entries of "14" and "05" are matches in order, whereas the rest of the entries are not matches.

In an embodiment, points are added to a matching score depending on the type of match. Two points can be added to the matching score if a match in order is found, one point can be added to the matching score for a match out of order, and zero points are added in case of no matches. In an embodiment, the matching rules and the corresponding points received for a partial or complete match are customizable. Other matching rules can be devised. A match in order can receive points equal to half of the length of either NLOGMAX or NLOGMIN, whereas a match in order can receive points equal to a quarter or some other fraction of the length of NLOGMAX or NLOGMIN.

All of the matching points are added to the matching score. The matching score is used for determination of the identity of the unknown sample. The total matching score is compared against a matching threshold. If the total matching score is below the matching threshold, then the unknown sample is unknown and no determination can be made. The matching threshold can be varied in order to increase or decrease the accuracy of the identification of the unknown sample.

An additional biometric or other sample identification algorithm embodiment consists of a template for each user, consisting of 128 frequencies for each of the four components measured by the scanning apparatus. The four components are the real and imaginary components of transmitted RF signals and the real and imaginary components of reflected RF signals. The set of 128 frequencies defines a template. The test consists of comparing a measurement taken with the template. Then the matches are counted between the measurement and the template, and if a match of about 75% or higher is achieved, then it is a correct identification of the user. A range can also be defined. The average score for people is expected to be in the 50% range, since the template itself is defined on a composite average. The template for a user is generated by determining how a user's signal amplitude compared to the norm at the given frequency. If the user's value is above the norm or standard value, then the result at that given frequency is encoded as a 1. On the other hand, if the user's value is below the norm, then the result at that given frequency is encoded as a 0. This consists of the process of registering a user and the set of 1s and 0s for the four components define a template or code for a person.

During a determination scan of a first user, the scanning apparatus measurements for the first user are compared with the norm, as during the registration process. The determination of the first user is done by counting the number of matches of 1s and 0s in the determination scan with the registration scan. The count is computed as a percentage of the total possible number of matches. For example, if there are a total of four columns with 128 frequencies, for a total of 512, then the percentage out of 512 that match would give a measurement of determination. In an embodiment, each column or component has a minimum requirement it must meet. For example, each of the four components must match at least 70% or at least 60%, instead of combining them all together. This would prevent one component from having a 90% match and a second component from having a 60% match, which would not yield an accurate determination.

Returning now to the glucose monitoring application embodiment, glucose monitoring is typically repeated frequently and periodically to obtain a series of glucose amounts or concentrations, in the subject, at selected time intervals. The glucose monitoring device used in an embodiment may have an alert system, where an alert is provided to the subject (for example an auditory alert) when glucose levels should be checked, when levels exceed predetermined threshold values, when levels change at a rate faster than the predetermined rate of change, or when a predicted glucose value for a later time point falls outside of the predetermined range.

A caloric intake and caloric output record may be input into the glucose monitoring device itself, or into a related device (such as a computer or personal digital assistant, where, for example, the personal digital assistant is operatively connected, at least periodically, with the record of glucose values obtained by the glucose monitoring device). Alternatively, such a record may be manually maintained. This record is then compared to the series of glucose amounts or concentrations and the predetermined reference ranges to evaluate compliance with the reference range of glucose amounts or

concentrations to achieve the weight management goal of the subject. The weight management goal may be weight gain in the subject, weight reduction in the subject, and weight maintenance in the subject.

Recorded caloric levels could also be shared with third party software products utilized to help subjects manage their weight. Software for enabling subjects to monitor caloric intake and utilization could use the information collected by the present system to assist the subject's weight management objectives. For example, Weight Watchers International, Inc. provides a web-based caloric intake and utilization system called Points® Tracker, that requires subjects to record the calories, fat and fiber for everything they eat during the course of a day (or to select from a menu of food items that already includes calorie, fat and fiber quantities), and to record their activity for that day. The food and activity are then assigned points that are deducted from or added to a target the subject has for each day, and for a week. By utilizing input data from the glucose monitoring device, it would be possible for a system like the Points Tracker to further monitor the subject. If a subject's glucose levels were rising, but the subject had not entered enough consumed food to fully account for the higher glucose levels, the Points Tracker could alert the subject to enter additional items or it could reduce the subject's points total to account for the increased calorie count. Alternatively, the point tracking system or some other weight management system could be modified to calculate points or weight management progress based just on the output of the glucose monitoring system.

Another aspect of an embodiment relates to a method for performance management. In the method, glucose monitoring in the subject may be carried out by the method described above. When attempting to maximize athletic potential, it is just as important for an athlete to make sure they do not have excessive amounts of glucose in their system as insufficient levels. Excessive glucose levels in the blood can result in a number of symptoms, including: anxiety, congestion, migraines, asthma, depression, hypoglycemia, digestive issues, visual impairment, joint/muscle pain, fainting, lack of mental control, and short term memory loss. Athletes consuming massive amounts of sugar in hydration drinks on the sidelines of sporting events may not be aware of the potential consequences of their sugar intake levels. Enabling such athletes to easily, effectively and non-invasively monitor their glucose levels will help them monitor sugar intake levels and switch to plain water or other supplements when appropriate.

In this method, a reference range of glucose amounts or concentrations is typically determined that corresponds to maintaining an optimal range of glucose amounts or concentrations in the subject during exercise, training or competition. The reference range comprises, for example, a high threshold glucose value, a low threshold glucose value, a predetermined rate of change (e.g., glucose levels change at a rate faster than a predetermined rate of change), and/or a predicted glucose value for a later time point. The glucose monitoring device may provide an alert system corresponding to threshold values, rate changes, a predicted glucose value that falls outside the predetermined range, etc.

Furthermore, as a component of the performance management method, lipid and glycogen monitoring in the subject may be carried out by the method described above. Since nearly all of the energy needed by the human body is provided by the oxidation of carbohydrates and lipids, an optimal performance management method includes the continuous monitoring of lipids as well as of carbohydrates.

Lipids are a broad group of naturally-occurring molecules which includes fats, waxes, sterols, fat soluble vitamins, (e.g.,

vitamin A and vitamin E), glycerides, phospholipids, and others. The main biological functions of lipids include energy storage, as structural components of cell membranes, and as important signaling molecules. Although the term lipid is sometimes used as a synonym for fats, fats are a subgroup of lipids called triglycerides. Lipids also encompass molecules such as fatty acids and their derivatives (including tri-, di- and monoglycerides and phospholipids), as well as other sterol-containing metabolites such as cholesterol.

Triglycerides (more properly known as triacylglycerols) are glycerides whereby the glycerol portion of the molecule is esterified with three fatty acids—carboxylic acid moieties at one end of unbranched, aliphatic chains. Triglycerides are a major form of energy storage in animals and make up most of the fats digested by humans; they are the main constituent of vegetable oil and animal fats. Triglycerides also contain more than twice as much energy (9 kcal/g) as carbohydrates and proteins.

In the intestine, triglycerides are split into monoacylglycerols, aka monoglycerides, and free fatty acids in a process called lipolysis. These products are subsequently routed to absorptive cells that line the intestines. There, the triglycerides are rebuilt from their fragments and packaged together with cholesterol and proteins to form chylomicrons. The chylomicrons are excreted by the cells and collected by the lymph system and transported to the large vessels near the heart before being mixed into the blood. Various tissues can capture the chylomicrons, thereby releasing the triglycerides to be used as a source of energy.

Fatty acids differ in length, may be saturated or unsaturated, and may exist in different configurations; i.e., cis or trans. These differences in geometry, as well as between being saturated and unsaturated, play an important role in biological processes, and in the construction of biological structures (such as cell membranes). Fatty acids can be bound or attached to other molecules, such as in triglycerides or phospholipids. When they are not attached to other molecules, they are known as free fatty acids and may come from the breakdown of a triglyceride into its components (fatty acids and glycerol).

Fatty acids are an important source of energy for many tissues since they can yield large quantities of adenosine triphosphate (ATP); many cell types can use either glucose or fatty acids for this purpose. In particular, the brain cannot use fatty acids as a source of energy; it relies on glucose or on ketone bodies. However, heart and skeletal muscle prefer fatty acids as energy sources.

Whereas carbohydrates provide a readily available source of energy, lipids function primarily as an energy reserve. The amount of lipids stored as an energy reserve far exceeds the energy stored as glycogen since the human body is incapable of storing as much glycogen compared to lipids. Lipids yield 9 kcal of energy per gram while carbohydrates and proteins yield only 4 kcal of energy per gram.

For example, in a typical 154 lb male, the free glucose in the blood provides only a 40 kcal energy reserve—only enough to maintain body functions for a few minutes. Alternatively, glycogen remaining stored in the liver and muscles after an overnight fast, amounts to about 600 kcal of available energy; glycogen reserves can maintain body functions for about one day without new inputs of food. On the other hand, lipid reserves containing 100,000 kcal of energy can maintain human body functions without food for about 30-40 days with sufficient water. Since many athletes train or compete in events for more than just a few minutes, it would be to their advantage to be able to monitor not only their glucose levels

during their activities but also their glycogen and lipid levels as part of their performance management regiment.

Additionally, as yet another component of the performance management method, electrolyte monitoring in the subject may be carried out by the method described above. Electrolytes are substances containing free ions that behave as an electrically conductive medium. Because they generally consist of ions in solution, electrolytes are also known as ionic solutions. Electrolyte solutions are normally formed when a salt is placed into a solvent such as water. For example, when table salt, NaCl, is placed in water, the salt (a solid) dissolves and dissociates into its component ions, sodium cations and chloride anions.

Physiologically, electrolytes are what cells (especially nerve, heart and muscle) use to maintain voltages across their cell membranes and to carry electrical impulses (nerve impulses, muscle contractions) across themselves and to other cells. The kidneys work to keep the electrolyte concentrations in the blood constant despite changes to them in the body. For example during exercise, electrolytes, particularly sodium and potassium are lost in one's sweat. Subjects performing in extreme conditions for long periods of time, i.e., during a marathon, who do not consume electrolytes both during and after the activity risk being subject to cramps as a result of the electrolyte imbalance. These electrolytes must be replaced in order to maintain appropriate electrolyte concentrations in the body. Consequently, athletes are encouraged to drink sports drinks rather than pure water after exercising as many sports drinks have sodium chloride or potassium chloride added to them to replenish the electrolytes lost during their activity and to restore their electrolyte balance.

To date, measurement of electrolytes is commonly performed by medical technologists via blood testing or urinalysis using complex instrumentation such as ion selective electrodes. However, the interpretation of these values is somewhat meaningless without analysis of the clinical history and is often impossible without parallel measurement of renal function. As a result, a simple and easy, self-administered, and continuous method of determining an athlete's electrolyte levels both during and after prolonged workout regimens or competitions would be invaluable in preventing inadequate electrolyte concentration maladies and to provide for quick recovery and optimum performance.

When a person sweats, small amounts of electrolytes, e.g., sodium ions, chloride ions, and potassium ions are lost from the body along with water. During most activities, one's performance is not adversely affected by the loss of moderate quantities of electrolytes in their sweat, and the person merely becomes dehydrated; replenishment of necessary water followed by a normal diet typically restores a person's electrolyte levels promptly without any ill side effects to the individual. However, during extremely demanding endurance events that result in the loss of higher concentrations of electrolytes and water, one may experience muscle cramps, dizziness, fainting or even death. Studies have shown that by replenishing electrolytes both during and after strenuous activities, one can avoid these negative outcomes. However, the body's method of alerting an individual that its electrolyte levels have reached a critical low is by way of these symptoms in which it is too late and performance will suffer.

While the present invention has been illustrated and described herein in terms of several embodiments, it is to be understood that the techniques described herein can have a multitude of additional uses and applications. Accordingly, the invention should not be limited to just the particular description and various drawing figures contained in this

specification that merely illustrate embodiments and applications of the principles of the invention.

What is claimed is:

1. A method for assisting a subject to manage a weight of the subject, comprising the steps of:

transmitting a series of separately transmitted electromagnetic signals over a range of distinct frequencies from a transmitter through a finger of the subject to a receiver to create a series of corresponding spectral data sets including each of the separately transmitted electromagnetic signals received by the receiver;

developing the series of corresponding spectral data sets into one or more composite spectrograms including each of the separately transmitted electromagnetic signals received by the receiver;

analyzing the one or more composite spectrograms to recognize a series of patterns within the one or more composite spectrograms that directly represent a glucose level in the subject;

repeating the steps of transmitting, developing, and analyzing to obtain a series of glucose levels in the subject over a period of time; and

utilizing the series of glucose levels to determine a record of caloric intake and caloric output that will assist the subject in managing the subject's weight of the subject.

2. A method for evaluating a compliance of a subject with a weight management program by monitoring a characteristic in said subject, comprising the steps of:

placing a sample of the subject in a sample holder;

scanning said sample with a scanner module, wherein said scanner module includes a transmitter for transmitting a series of separately transmitted electromagnetic signals, each signal in said series of separately transmitted electromagnetic signals having a transmitted amplitude over a plurality of sample points within a range of distinct frequencies, and a receiver for receiving said series of separately transmitted electromagnetic signals as said series of separately transmitted electromagnetic signals are reflected from or transmitted through said sample;

generating a series of spectral data sets representing at least a scanned amplitude of each signal in said series of separately transmitted electromagnetic signals over said plurality of sample points, said scanner module including a transmitter node having a first dipole antenna connected to said transmitter and a receiver node having a second dipole antenna connected to said receiver,

said scanner module including a base formed to hold said transmitter node and said receiver node close to or in contact with said sample;

determining said characteristic of said sample with an analyzer module, wherein said analyzer module includes a memory and a processor for generating one or more composite spectrograms from said series of spectral data sets including each signal in said series of separately transmitted electromagnetic signals;

analyzing said one or more composite spectrograms to recognize one or more patterns within said one or more composite spectrograms directly representing said characteristic of said sample;

making a determination regarding said characteristic based on said one or more patterns;

repeating the placing the sample step to the making a determination step to obtain a series of glucose levels in said subject over a period of time; and

utilizing the series of glucose levels to determine a record of caloric intake and caloric output that will assist said subject in managing a weight of said subject.

3. The method as recited in claim 2, further comprising the step of measuring real components and imaginary components of said series of separately transmitted electromagnetic signals received, wherein said real components represent purely resistive properties of said sample and wherein said imaginary components represent capacitive and inductive properties of said sample.

4. The method as recited in claim 3, further comprising the steps of:

registering a known first sample with said analyzer module based on a variety of known conditions; and

analyzing a second sample to determine an unknown condition for said second sample, wherein said unknown condition is one that was registered with said analyzer module using said known first sample.

5. The method as recited in claim 4, wherein said sample is at least a portion of a human.

6. The method as recited in claim 5, wherein said characteristic is a glucose level.

7. The method as recited in claim 6, further comprising the steps of:

developing a set of measurements for different glucose levels comprising, testing a first glucose level in said human after fasting with a traditional glucose meter using a first finger of said human, then placing a second finger of said human into said scanner module for scanning;

having said human drink a highly sweetened liquid to cause a glucose level of said human to rise;

testing a second glucose level in said human after consumption of said highly sweetened liquid with said traditional glucose meter using said first finger of said human, then placing said second finger of said human into said scanner module for scanning; and

testing a third glucose level in said human after said glucose level of said human has returned to a normal level with said traditional glucose meter using said first finger of said human, then placing said second finger of said human into said scanner module for scanning,

thereby developing a set of measurements corresponding to low, high and normal glucose levels in said human.

8. The method as recited in claim 7, further comprising the step of measuring an unknown glucose level in said human, the step of measuring an unknown glucose level comprising the steps of:

placing at least said portion of said human into said scanner module for scanning;

scanning said portion of said human to develop a series of spectral data sets for said human;

generating said composite spectrograms from said series of spectral data sets for said human;

making a determination of said unknown glucose level in said human from said composite spectrograms;

correlating said determination with said set of measurements corresponding to low, high and normal glucose levels in said human; and

identifying said unknown glucose level in said human based on the correlating step.

9. The method as recited in claim 6, further comprising the step of applying a correction factor application, wherein said application uses different measured scan parameters to compensate for changes to analytes other than glucose that occur in response to said human drinking said highly sweetened liquid; and/or wherein said application uses different measured scan parameters to compensate for changes to a tem-

51

perature of said human, hematocrit levels, and blood pressure that occur in response to said human drinking said highly sweetened liquid.

10. The method as recited in claim 2, wherein said step of analyzing includes comparing said one or more composite spectrograms against a library of known substances.

11. The method as recited in claim 2, wherein said sample is at least a portion of a human, wherein said characteristic is the glucose level of said human, and wherein the step of making said determination includes determining the glucose level of said human from a number of other glucose level patterns for said human stored in said memory.

12. The method as recited in claim 2, further comprising the step of determining a reference range of glucose amounts or concentrations that correspond to achieving a weight management goal in the subject.

13. The method as recited in claim 12, wherein said reference range is a range of glucose amounts or concentrations comprising a high threshold glucose value and a low threshold glucose value.

14. The method as recited in claim 12, further comprising the step of determining rates of change of glucose concentrations in the subject.

15. The method as recited in claim 12, further comprising the step of inputting the caloric intake record, wherein said caloric intake record is compared to the reference range of glucose amounts or concentrations to evaluate compliance with the reference range of glucose amounts or concentrations to achieve the weight management goal of the subject.

16. The method as recited in claim 15, further comprising the step of sharing said caloric intake record with a third party software product.

17. The method as recited in claim 12, further comprising the step of inputting a caloric output record, wherein said caloric output record is compared to the reference range of glucose amounts or concentrations to evaluate compliance with the reference range of glucose amounts or concentrations to achieve the weight management goal of the subject.

18. The method as recited in claim 17, further comprising the step of sharing said caloric output record with a third party software product.

19. The method as recited in claim 2, further comprising the step of providing said subject an alert when a condition is met.

20. The method as recited in claim 19, wherein said condition is when glucose levels need to be checked.

21. The method as recited in claim 20, wherein said condition is when glucose levels exceed predetermined threshold values.

22. The method as recited in claim 20, wherein said condition is when glucose levels change at a rate faster than a predetermined rate of change.

23. The method as recited in claim 20, wherein said condition is when a predicted glucose value for a later time point falls outside of a predetermined range.

24. The method as recited in claim 19, wherein said alert is an auditory alert.

25. The method as recited in claim 2, wherein said weight management program is used for monitoring weight gain in the subject.

52

26. The method as recited in claim 2, wherein said weight management program is used for monitoring weight reduction in the subject.

27. The method as recited in claim 2, wherein said weight management program is used for monitoring weight maintenance in the subject.

28. A method for performance management in a subject during exercise, training or competition by monitoring one or more characteristics in said subject comprising,

placing a sample of said subject in a sample holder;

scanning said sample with a scanner module, wherein said scanner module includes a transmitter for transmitting a series of separately transmitted electromagnetic signals, each signal in said series of separately transmitted electromagnetic signals having a transmitted amplitude over a plurality of sample points within a range of distinct frequencies, and a receiver for receiving said series of separately transmitted electromagnetic signals as said series of separately transmitted electromagnetic signals are reflected from or transmitted through said sample;

generating a series of spectral data sets representing at least a scanned amplitude of each signal in said series of separately transmitted electromagnetic signals over said plurality of sample points, said scanner module including a transmitter node having a first dipole antenna connected to said transmitter and a receiver node having a second dipole antenna connected to said receiver, said scanner module including a base formed to hold said transmitter node and said receiver node close to or in contact with said sample;

determining said one or more characteristics of said sample with an analyzer module, wherein said analyzer module includes a memory and a processor for generating one or more composite spectrograms from said series of spectral data sets including each signal in said series of separately transmitted electromagnetic signals;

analyzing said one or more composite spectrograms to recognize one or more patterns within said one or more composite spectrograms directly representing said one or more characteristics of said sample;

making a determination regarding said one or more characteristics based on said one or more patterns;

repeating the steps of placing the sample step to the making a determination step to obtain a series of glucose levels in said subject over a period of time; and

utilizing the series of glucose levels to determine a record of caloric intake and caloric output that will assist said subject in managing a weight of said subject.

29. The method as recited in claim 28, wherein said one or more characteristics is lipid level.

30. The method as recited in claim 29, wherein said one or more characteristics is glycogen level.

31. The method as recited in claim 29, wherein said one or more characteristics is glucose level.

32. The method as recited in claim 29, wherein said one or more characteristics are electrolyte levels.

* * * * *