



US008638053B2

(12) **United States Patent**  
**Ng**

(10) **Patent No.:** **US 8,638,053 B2**  
(45) **Date of Patent:** **Jan. 28, 2014**

(54) **MOTOR CONTROL CIRCUIT AND METHOD THAT SYNCHRONIZE A SPEED OF AN ELECTRIC MOTOR TO AN EXTERNAL CLOCK SIGNAL**

(75) Inventor: **Chee-Kiong Ng**, Acton, MA (US)

(73) Assignee: **Allegro Microsystems, LLC**, Worcester, MA (US)

(\*) Notice: Subject to any disclaimer, the term of this patent is extended or adjusted under 35 U.S.C. 154(b) by 217 days.

(21) Appl. No.: **13/278,458**

(22) Filed: **Oct. 21, 2011**

(65) **Prior Publication Data**

US 2013/0099706 A1 Apr. 25, 2013

(51) **Int. Cl.**  
**H02P 6/08** (2006.01)  
**H02P 6/16** (2006.01)

(52) **U.S. Cl.**  
USPC ..... **318/400.14**; 318/400.13; 318/400.2;  
318/400.3; 318/400.04; 318/400.01; 318/700;  
318/606; 318/607; 318/400.05

(58) **Field of Classification Search**  
USPC ..... 318/400.05, 400.01, 700, 400.14,  
318/400.13, 400.1, 400.3, 705, 606, 607,  
318/600, 400.2  
See application file for complete search history.

(56) **References Cited**

**U.S. PATENT DOCUMENTS**

4,223,261	A	9/1980	White	
4,494,052	A *	1/1985	Kelleher et al.	318/400.11
4,661,756	A	4/1987	Murphy et al.	
5,811,954	A	9/1998	Randall	
5,814,965	A	9/1998	Randall	
5,923,141	A	7/1999	McHugh	
7,085,484	B2	8/2006	Hara	

7,365,765	B2 *	4/2008	Dan	347/261
7,397,883	B2 *	7/2008	Hattori	375/376
7,509,032	B2 *	3/2009	Jami	388/811
7,541,760	B2 *	6/2009	Lin et al.	318/400.01
7,590,334	B2	9/2009	Yabusaki et al.	
7,747,146	B2	6/2010	Milano et al.	
8,259,150	B2 *	9/2012	Kubo	347/261
2012/0007529	A1 *	1/2012	Kim et al.	318/400.04

**FOREIGN PATENT DOCUMENTS**

JP	2005-110471	4/2005
JP	2006-058364	3/2006
JP	2006-287990	10/2006
JP	2009-124864	6/2009
JP	2011-109866	6/2011

**OTHER PUBLICATIONS**

“A4920 3-Phase Controller;” Allegro Microsystems, Inc. Concept Data Sheet; Jul. 8, 2011; 12 pages.

PCT International Search Report and Written Opinion of the ISA; dated Jul. 18, 2013; for PCT Pat. App. No. PCT/US2012/055422; 8 pages.

Ng; “Motor Control Circuit and Method that Reduce Speed Jitter of an Electric Motor;” U.S. Appl. No. 13/278,462, filed Oct. 21, 2011; 37 pages.

U.S. Appl. No. 13/271,723, filed Oct. 12, 2011.

Office Action dated Sep. 20, 2013; for U.S. Appl. No. 13/278,461; 13 pages.

Response fled Dec. 9, 2013; to Office Acton dated Sep. 20, 2013; for U.S. Appl. No. 13/278,461; 11 pages.

\* cited by examiner

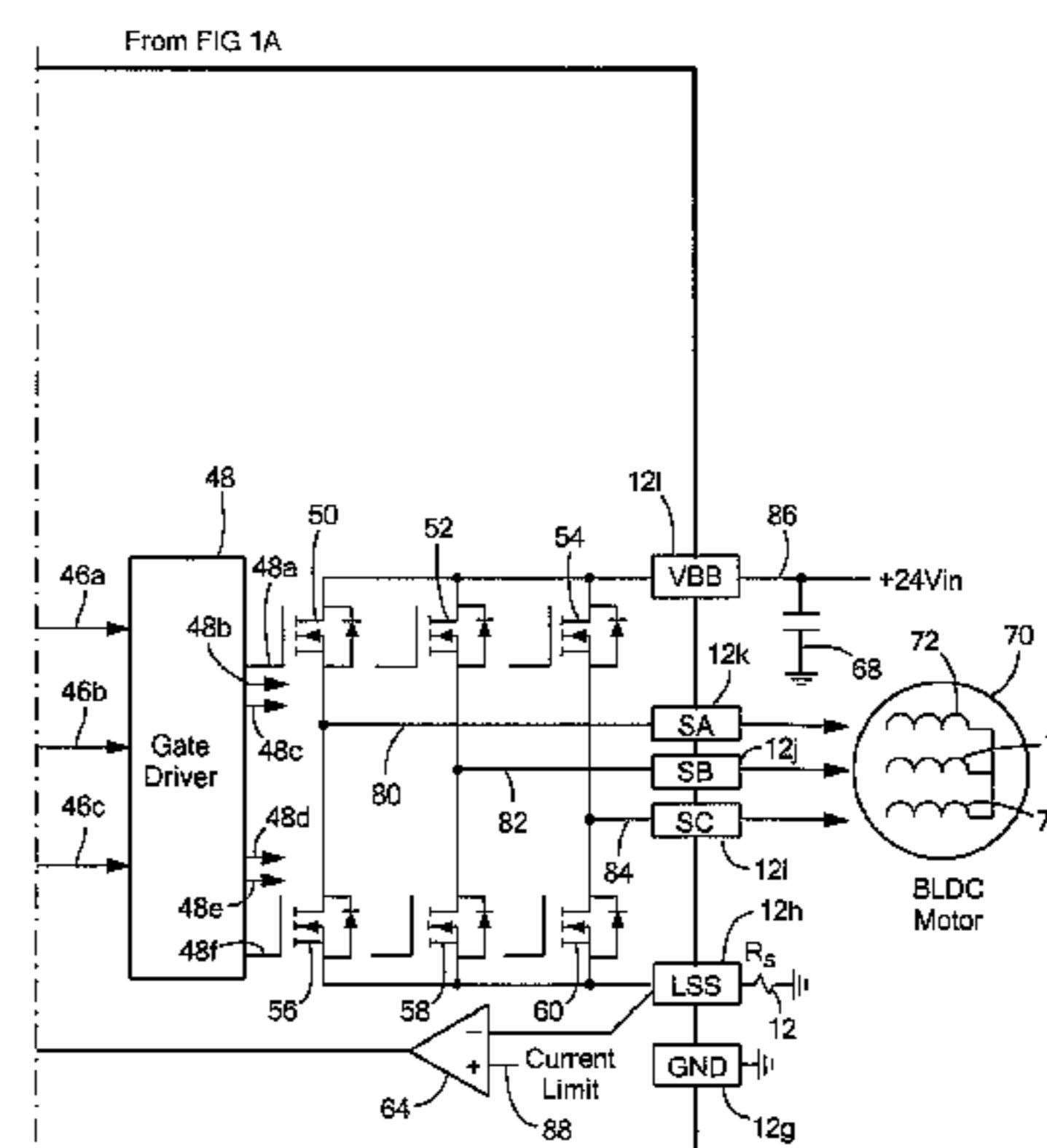
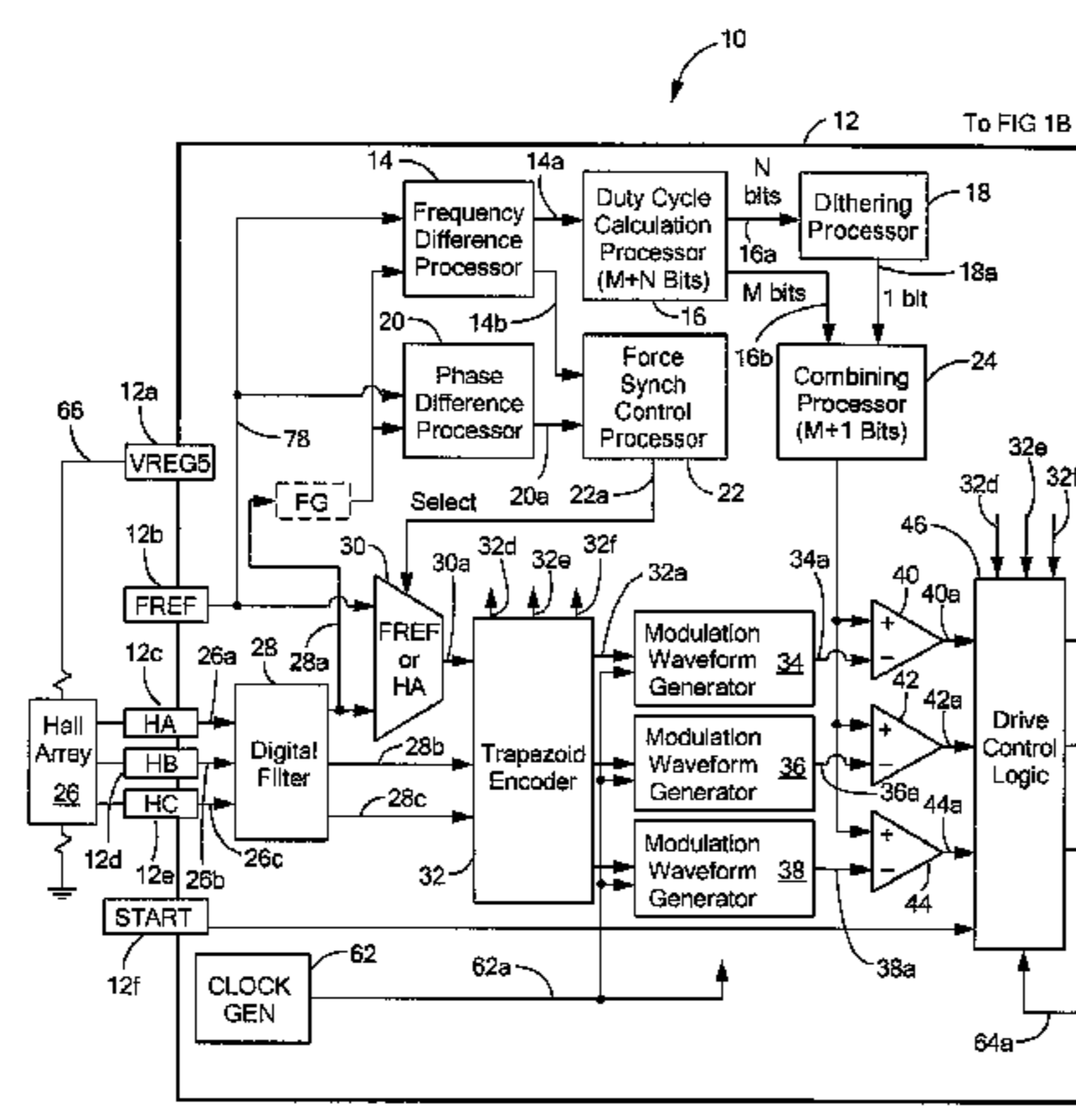
*Primary Examiner* — Rita Leykin

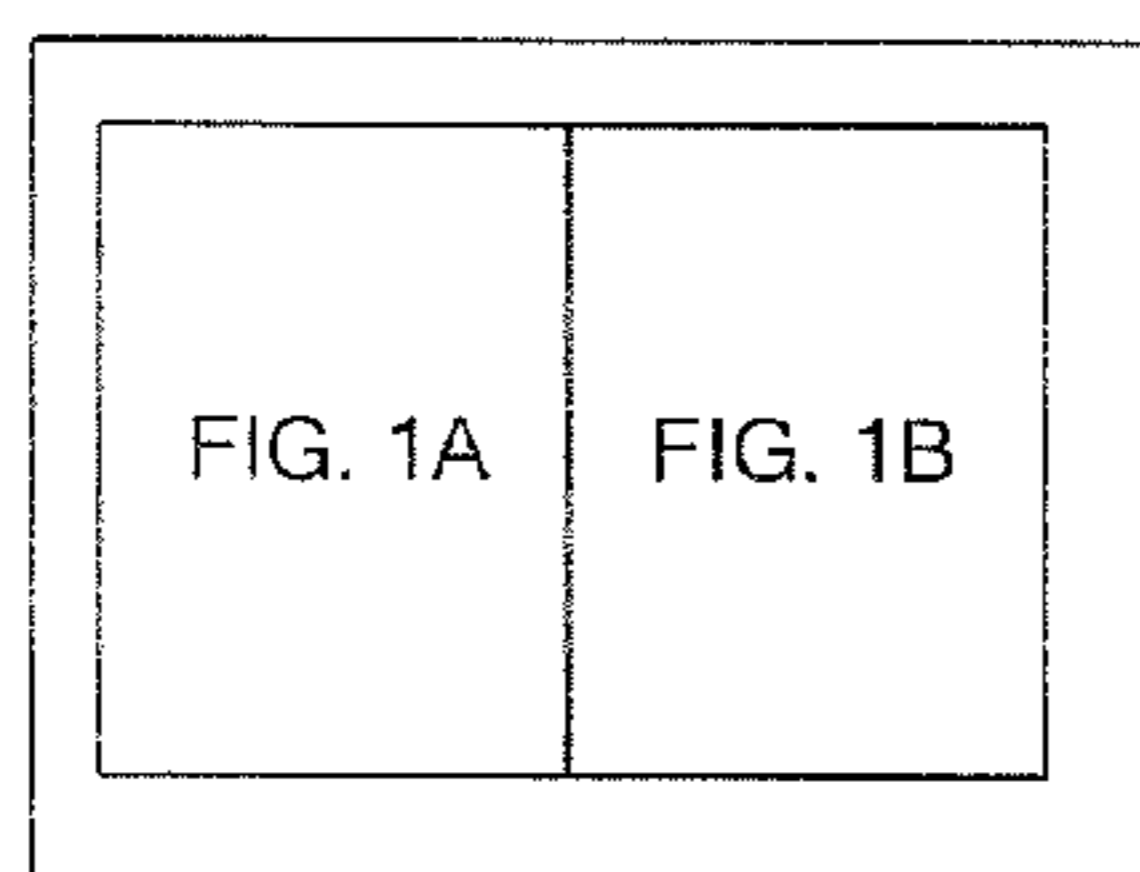
(74) *Attorney, Agent, or Firm* — Daly, Crowley, Mofford & Durkee, LLP

(57) **ABSTRACT**

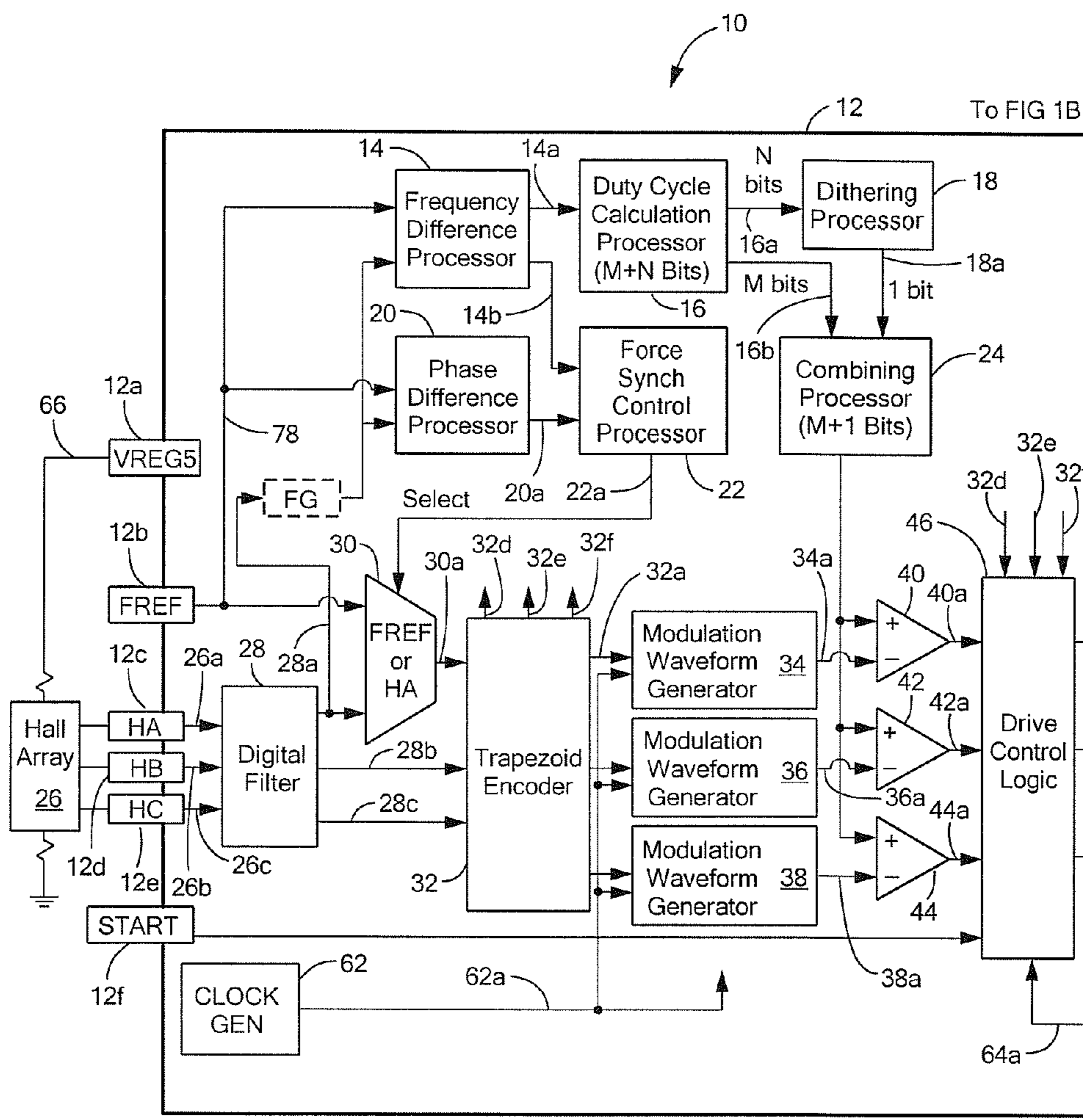
Motor control circuits and associated methods to control an electric motor provide an ability to synchronize a rotational speed of the electric motor with an external clock signal, resulting in reduced jitter in the rotational speed of the electric motor.

**22 Claims, 10 Drawing Sheets**

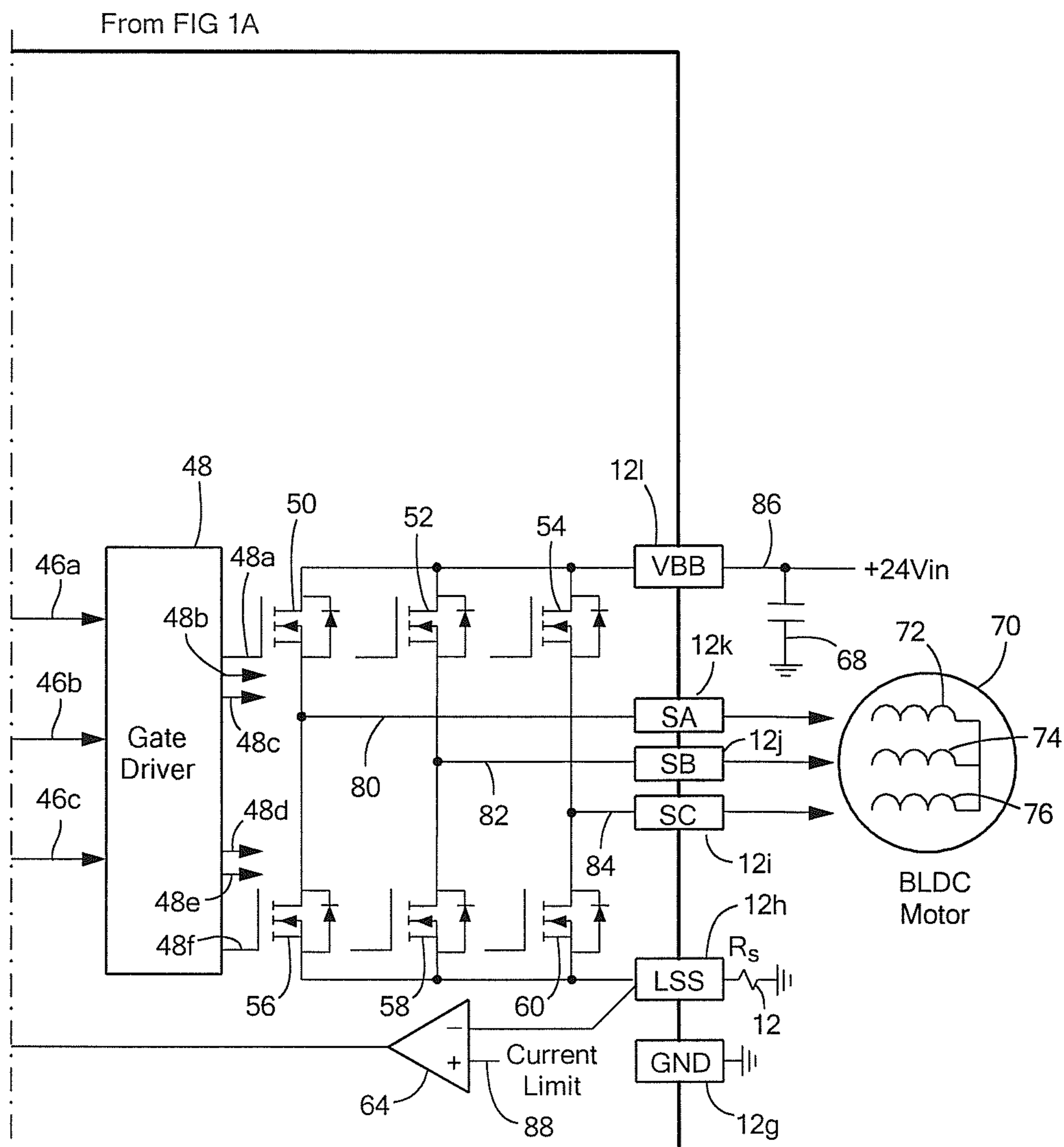




**FIG. 1**



**FIG. 1A**



**FIG. 1B**

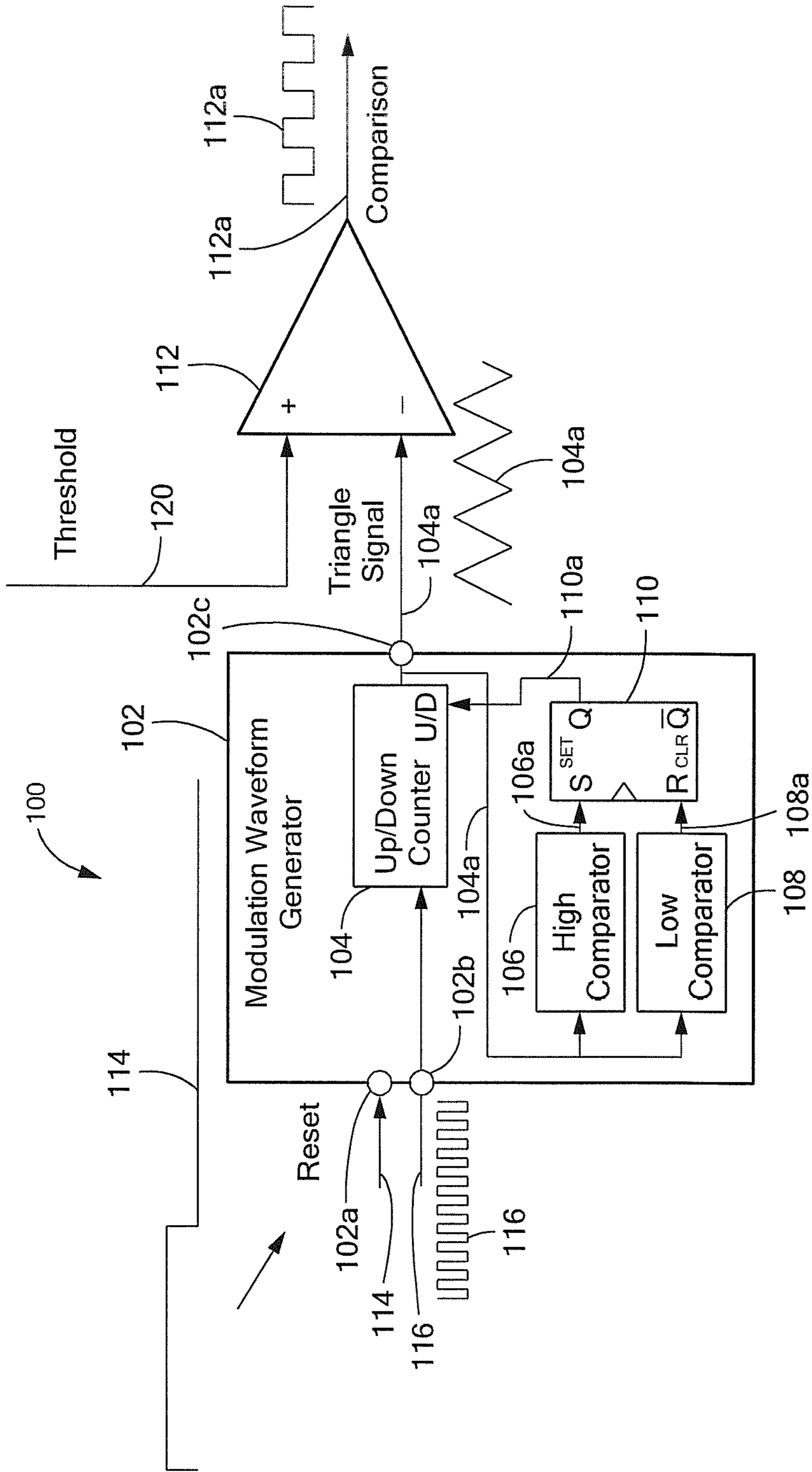
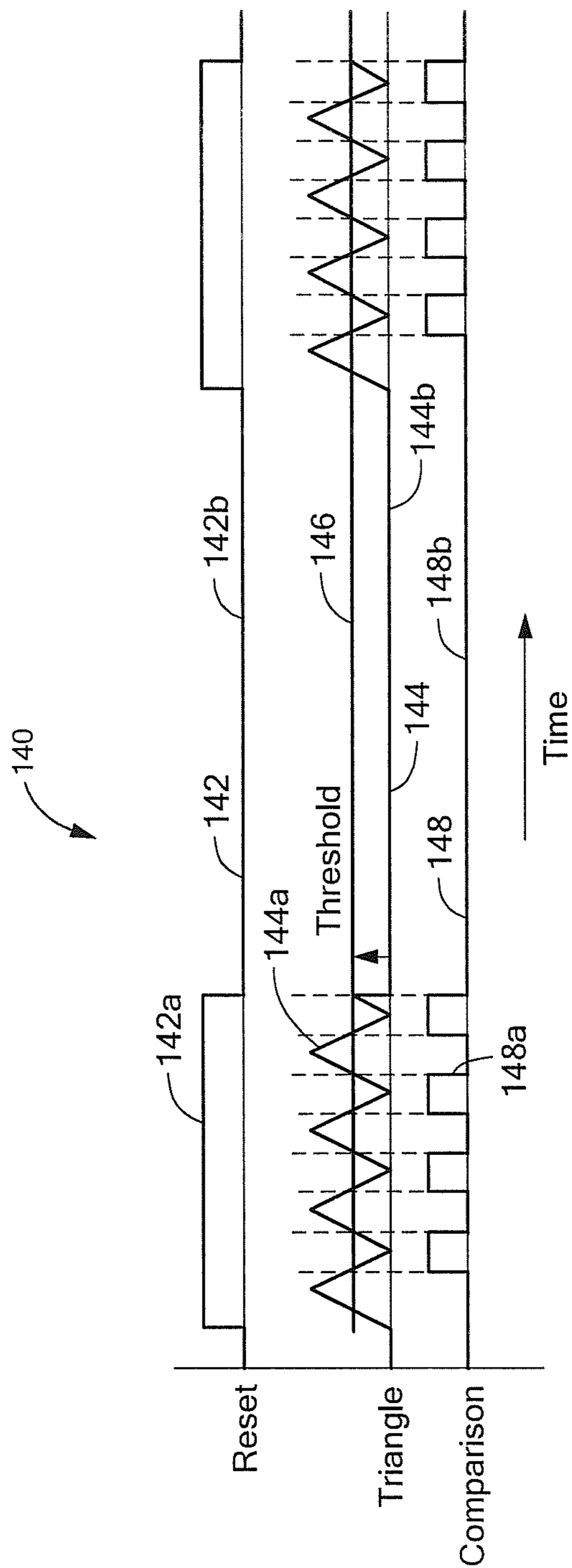
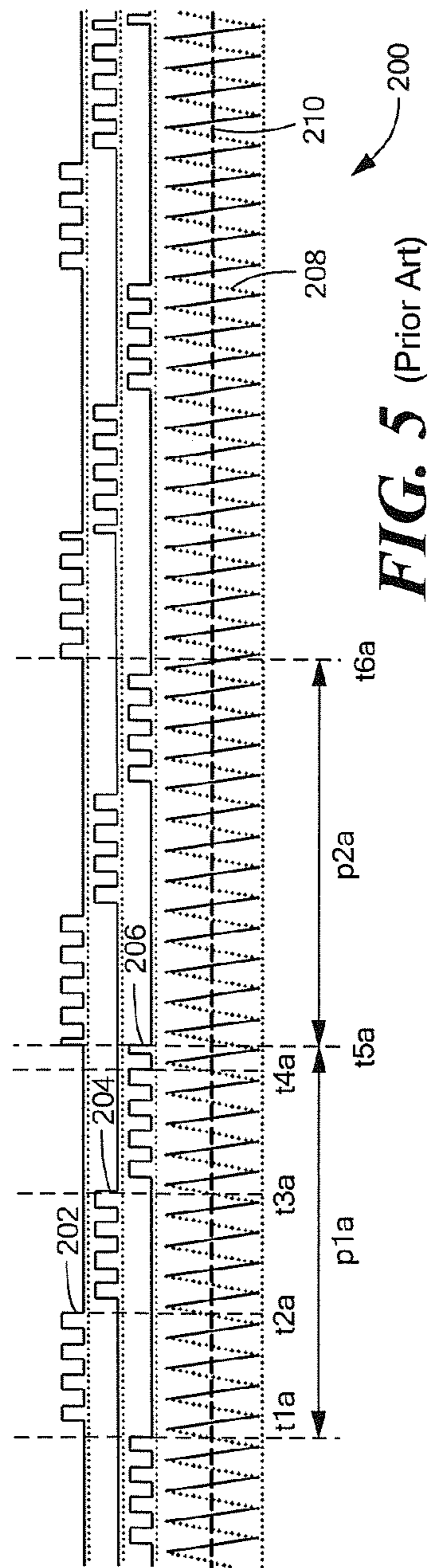
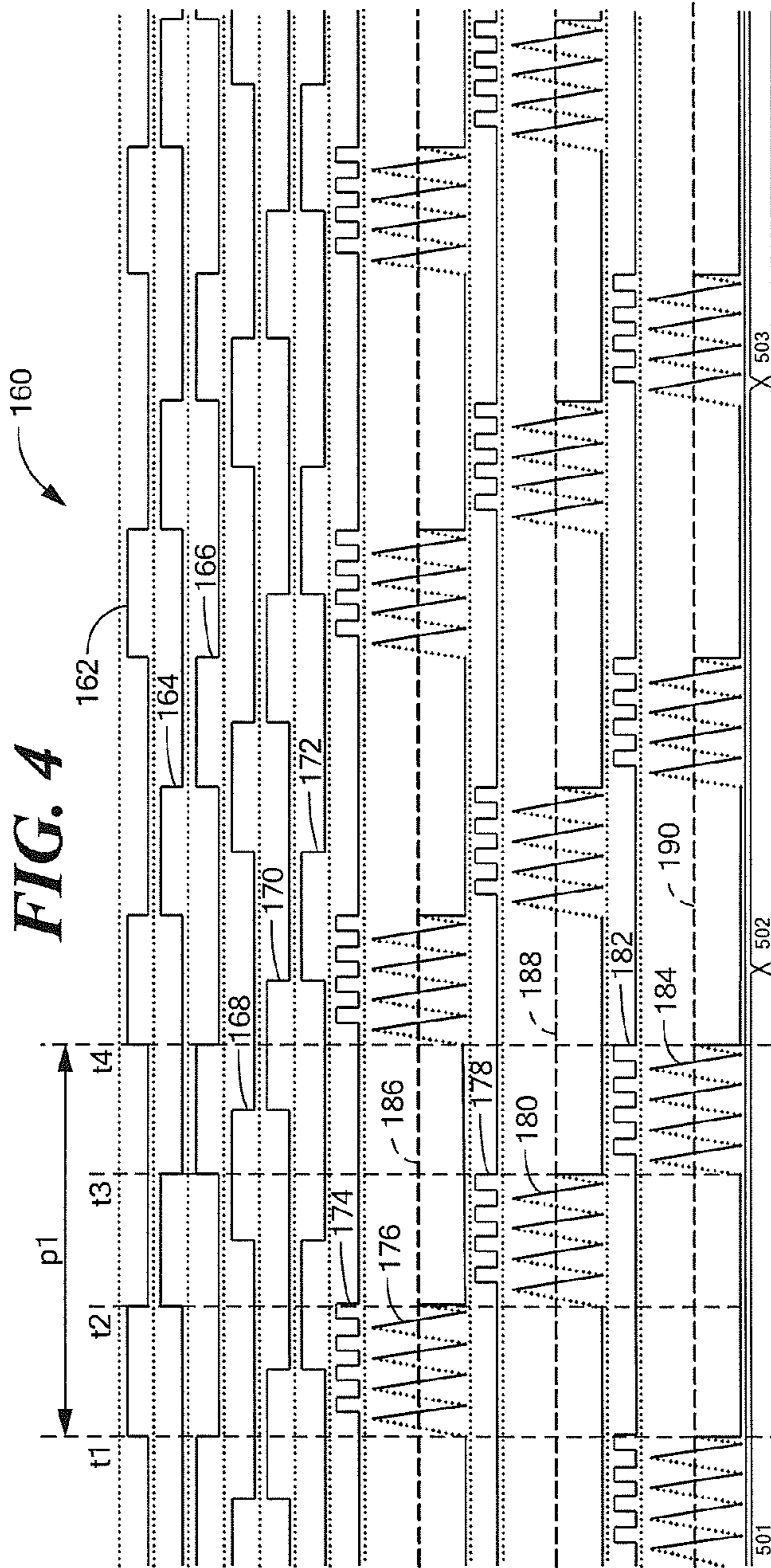
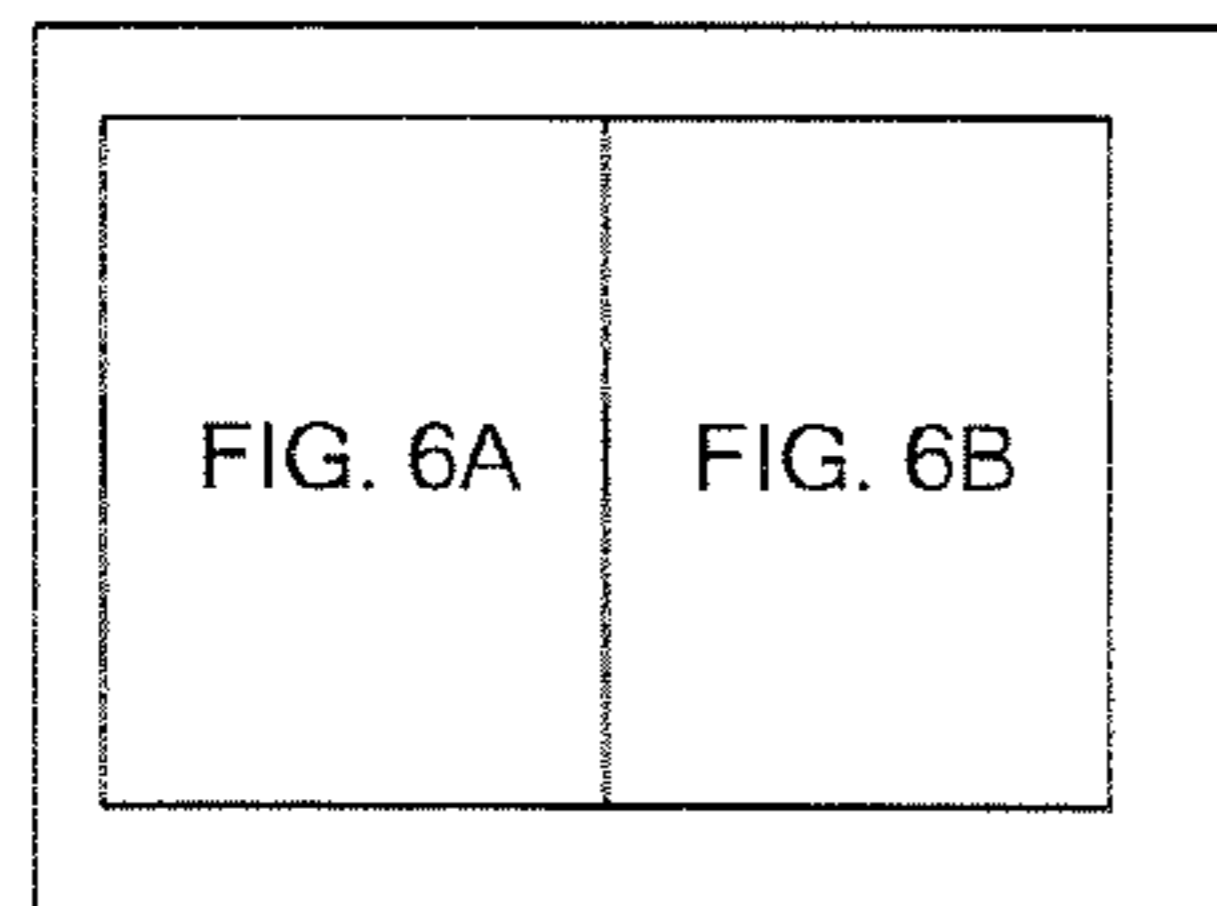


FIG. 2

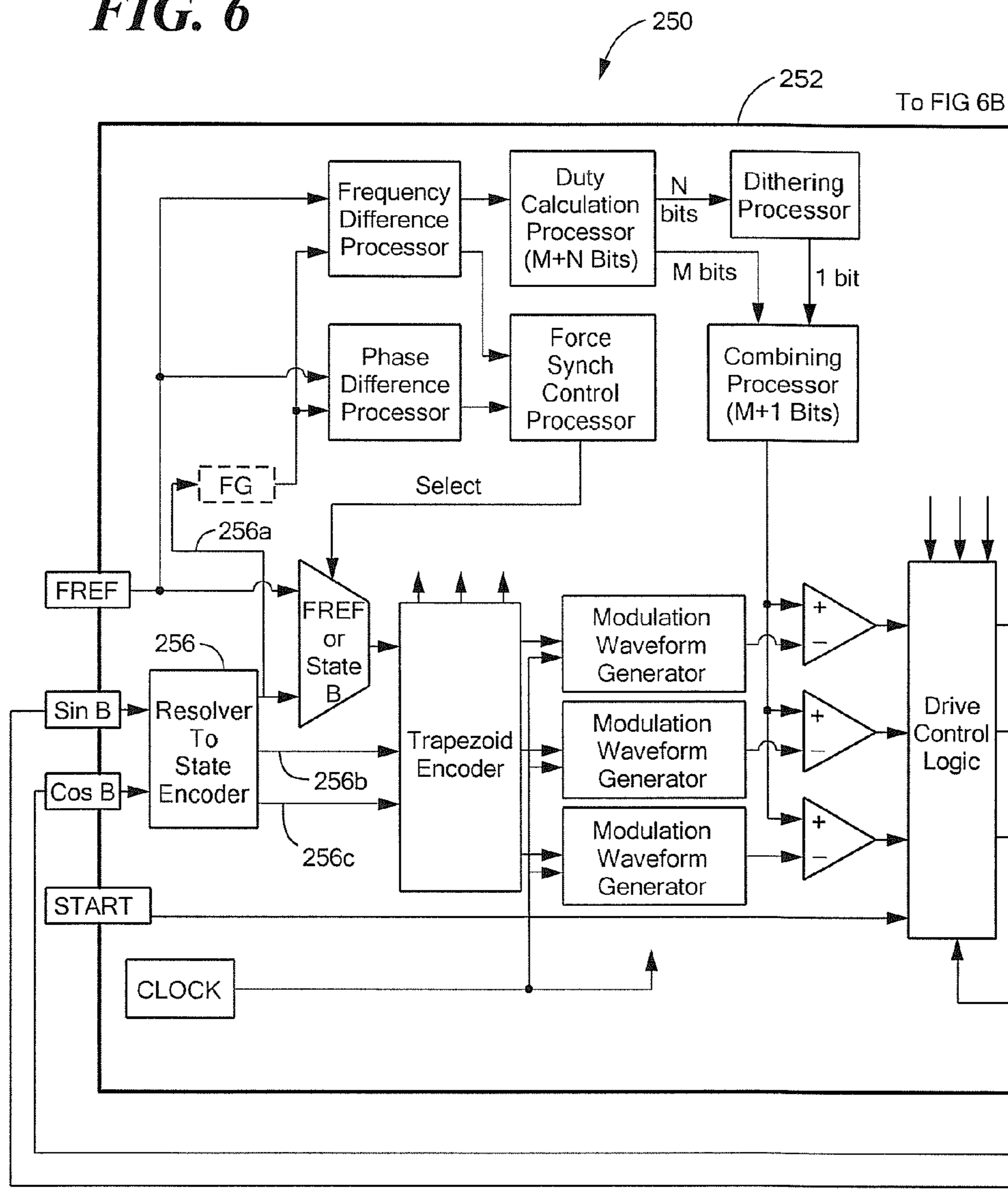


**FIG. 3**

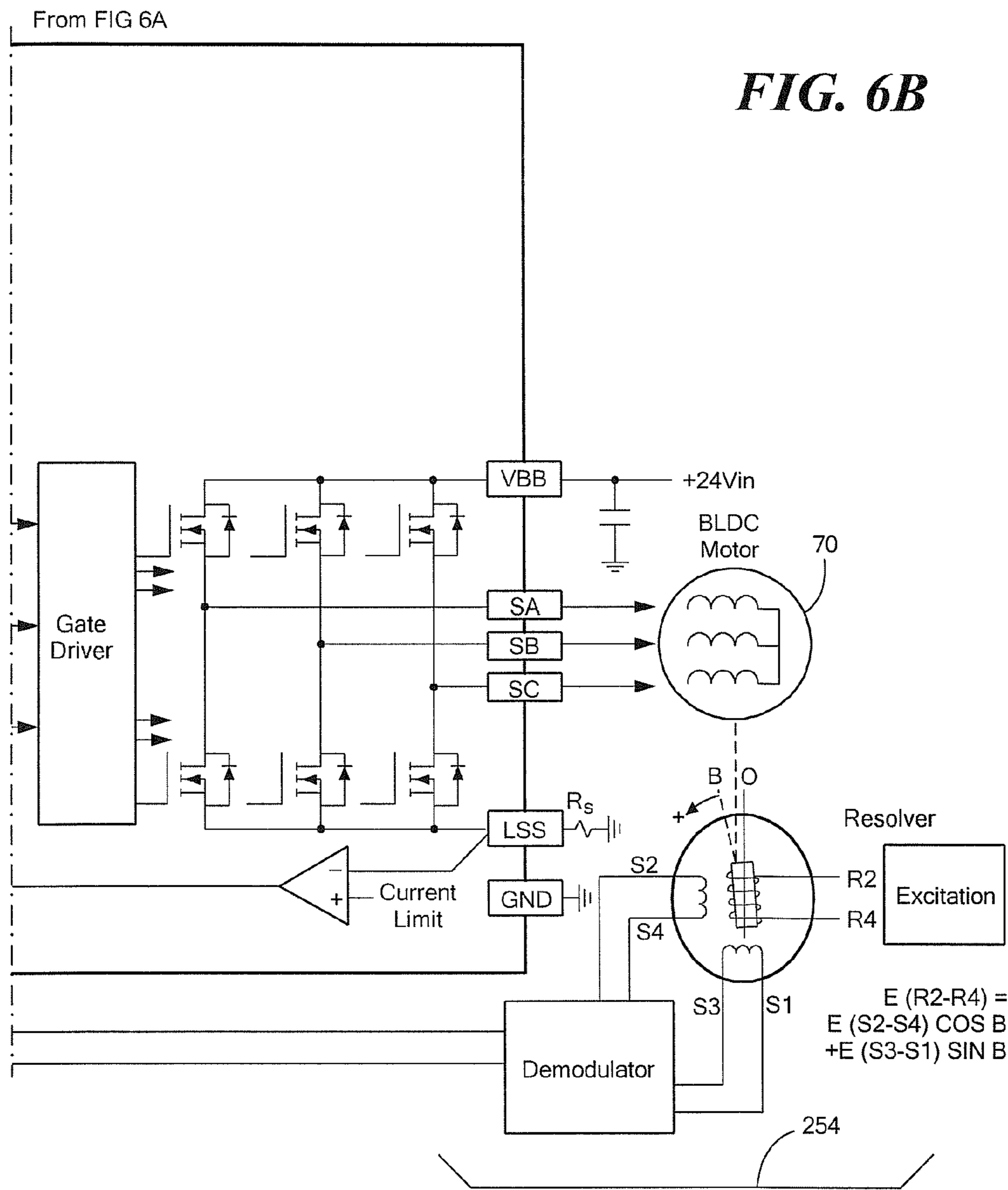




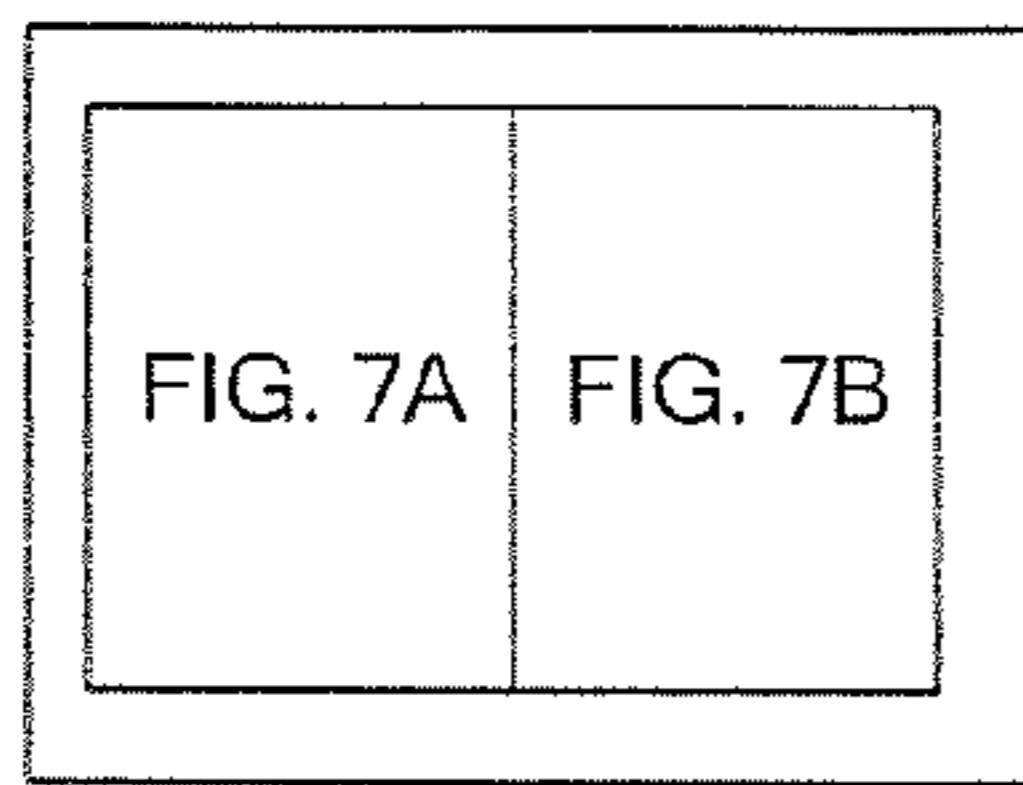
**FIG. 6**



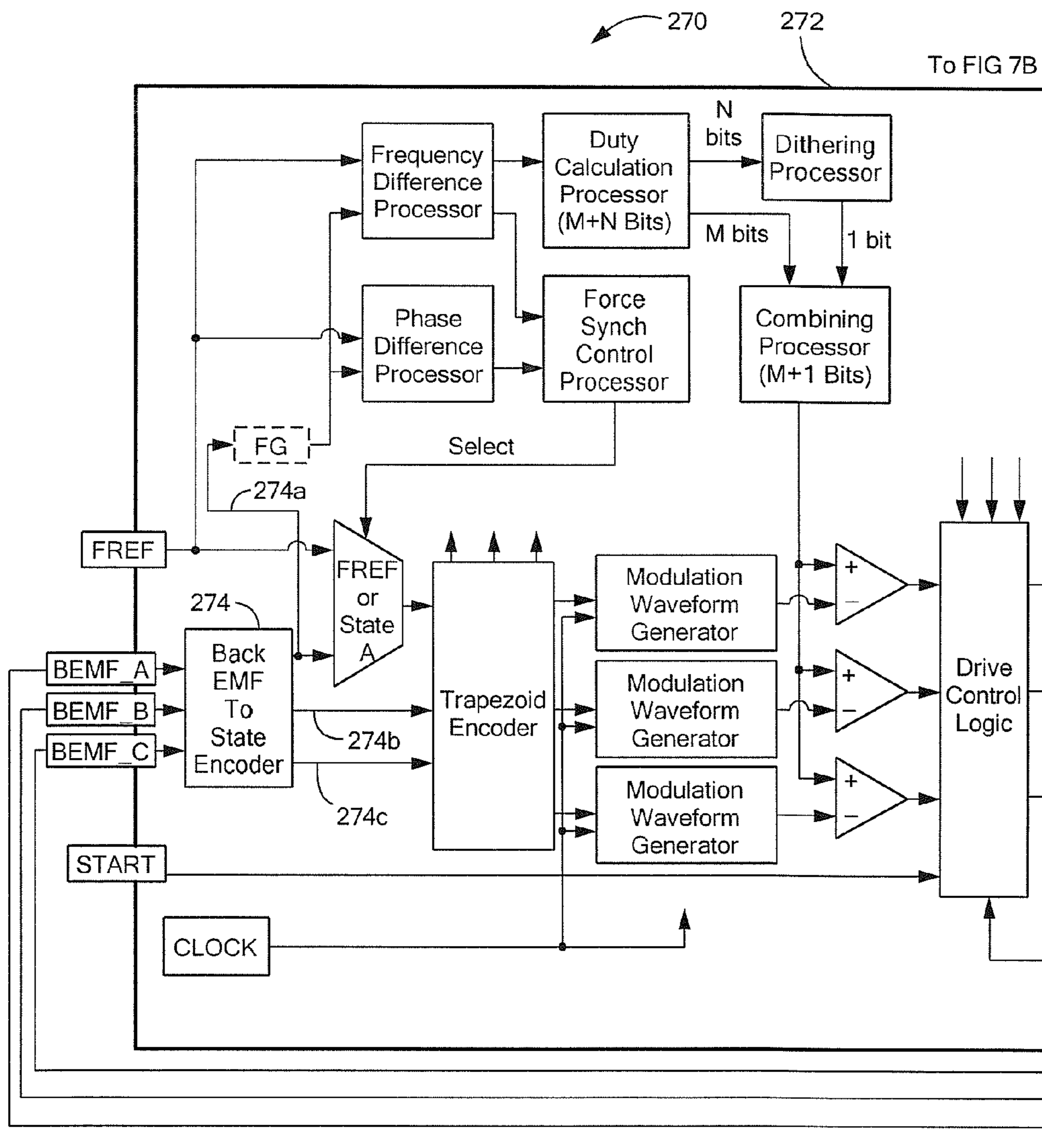
**FIG. 6A**



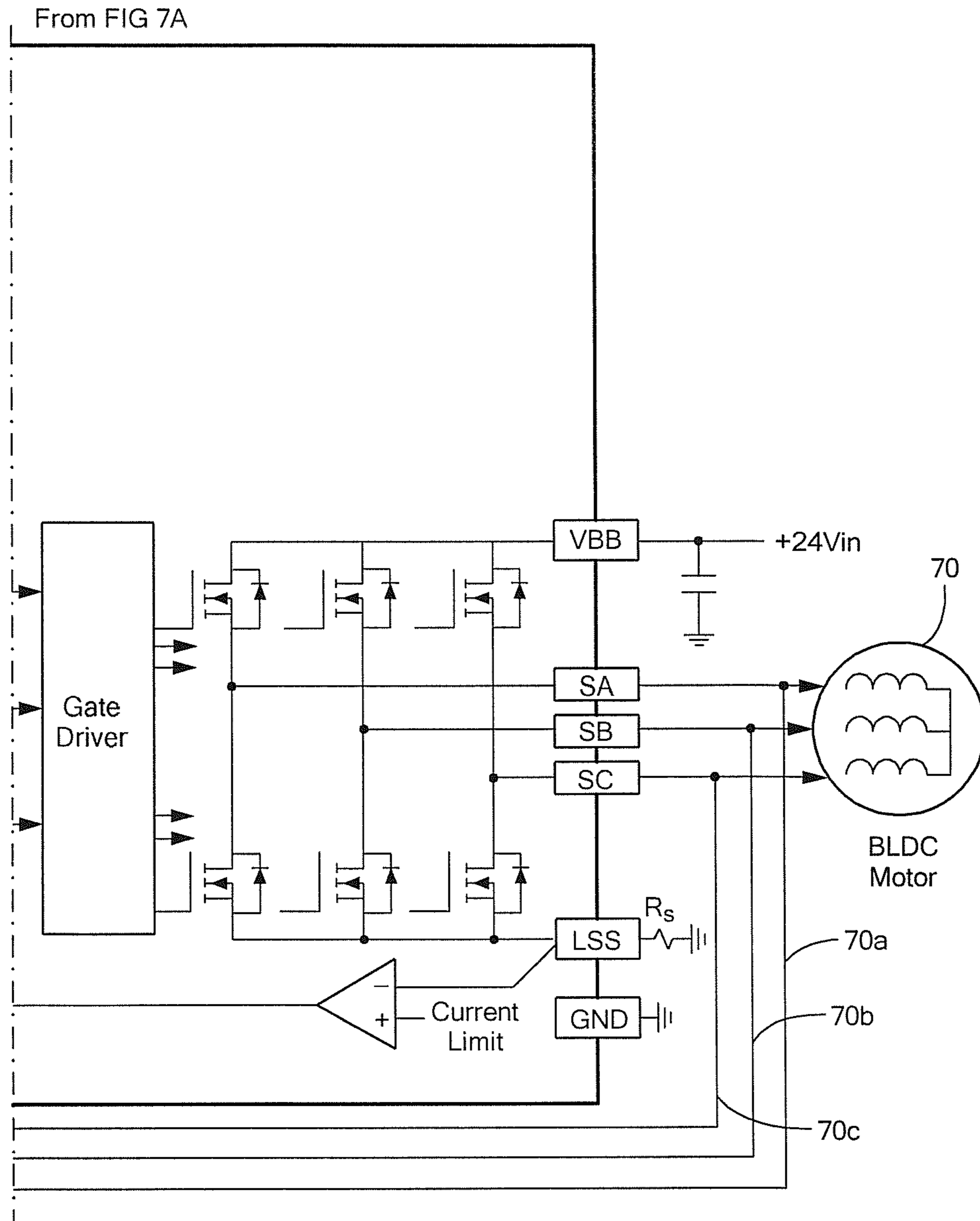




**FIG. 7**



**FIG. 7A**



**FIG. 7B**

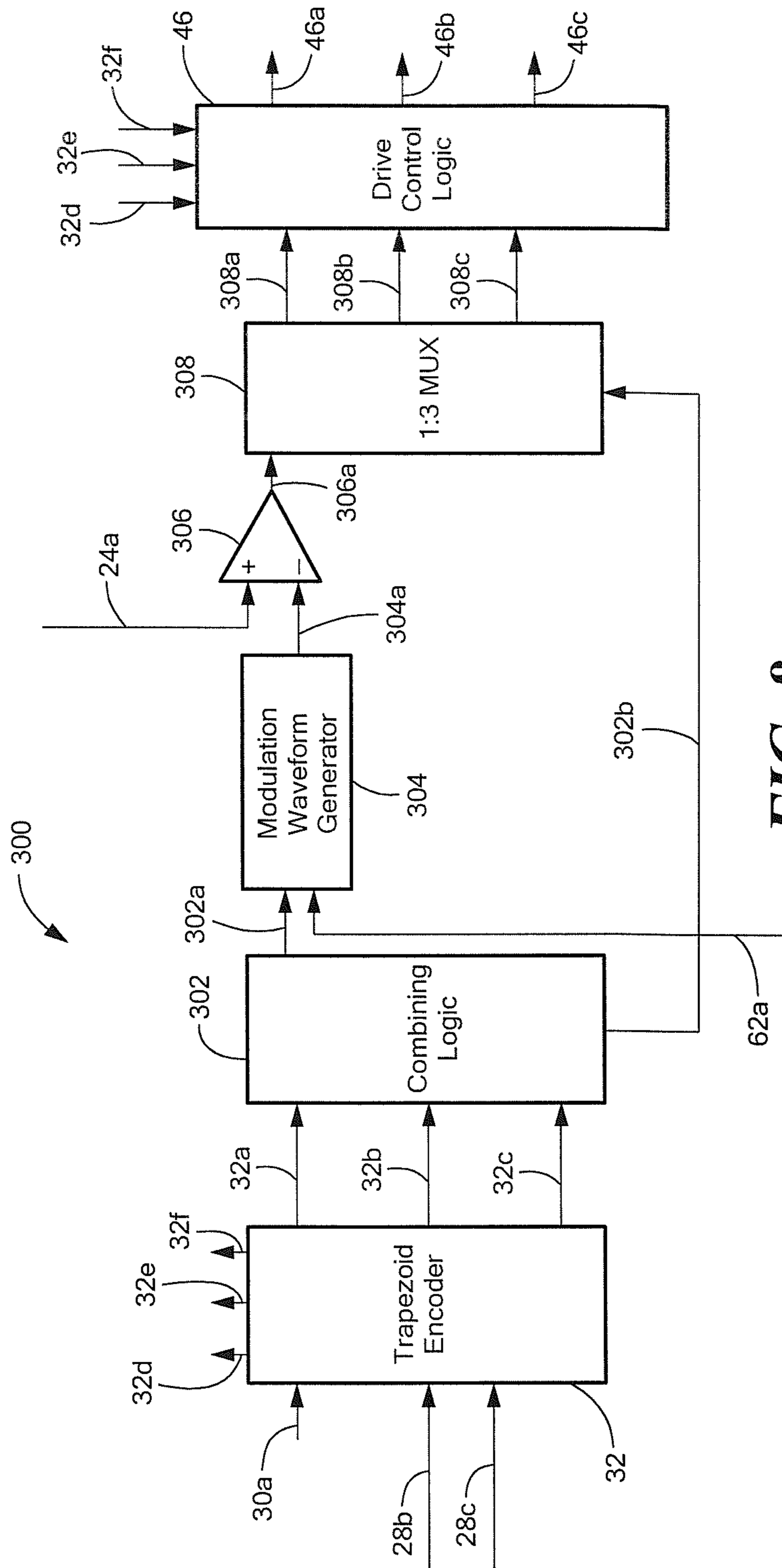


FIG. 8

1

**MOTOR CONTROL CIRCUIT AND METHOD  
THAT SYNCHRONIZE A SPEED OF AN  
ELECTRIC MOTOR TO AN EXTERNAL  
CLOCK SIGNAL**

CROSS REFERENCE TO RELATED  
APPLICATIONS

Not Applicable.

STATEMENT REGARDING FEDERALLY  
SPONSORED RESEARCH

Not Applicable.

FIELD OF THE INVENTION

This invention relates generally to electric motor control circuits and, more particularly, to an electric motor control circuit that can provide synchronization with an external frequency signal and that can also provide a reduced amount of motor speed jitter.

BACKGROUND OF THE INVENTION

Circuits to control and drive brushless DC (BLDC) electric motors are known. Conventionally, the circuits provide one function signal from which a plurality motor drive signals, each at a different phase, are derived.

Some known electric motor drive circuits are described in U.S. Pat. No. 7,590,334, issued Sep. 15, 2009, U.S. Pat. No. 7,747,146, issued Jun. 29, 2010, and U.S. patent application Ser. No. 13/271,723, filed Oct. 12, 2011 and entitled "Electronic Circuit And Method Generating Electric Motor Drive Signals Having Phase Advances In Accordance With A User Selected Relationship Between Rotational Speed Of An Electric Motor And The Phase Advances," each of which is assigned to the assignee of the present invention.

A BLDC electric motor can exhibit jitter in its speed of rotation when driven by a conventional motor drive circuit. In some applications, for example, motors used in printers, for example, inkjet printers, can experience an undesirable amount of jitter. In these particular applications, the jitter results in printing clarity reduction.

The amount of jitter in the rotational speed of electric motor driven by conventional motor control circuit is related to the fact that the above-described function signal within the motor control circuit does not necessarily align with the motor rotations such that an exact number of cycles of the function signal is achieved for each rotation of the motor.

In view of the above, it would be desirable to provide a motor control circuit and associated method that can generate electric motor drive signals to more accurately control, more accurately than a conventional motor control circuit, the speed of rotation of an electric motor, thereby reducing jitter in the rotational speed of the electric motor. It would also be desirable to provide a motor control circuit that can drive the motor at a rotational speed synchronized with an external clock signal received by the motor control circuit.

SUMMARY OF THE INVENTION

The present invention provides a motor control circuit and associated method that can generate electric motor drive signals to more accurately control, more accurately than a conventional motor control circuit, the speed of rotation of an electric motor, thereby reducing jitter in the rotational speed

2

of the electric motor. The present invention also provides a motor control circuit that can drive the motor at a rotational speed synchronized with an external clock signal received by the motor control circuit.

5 In accordance with one aspect of the present invention, a circuit for driving a multi-phase brushless DC motor, the motor having a motor shaft and a plurality of motor windings, includes a position signal generator configured to generate a plurality of position signals. Each one of the plurality of  
10 position signals is representative of a rotational position of the motor shaft. The circuit further includes a frequency difference processor coupled to receive a signal related to a selected one of the position signals, coupled to receive a reference clock signal, and configured to generate a frequency difference value related to a frequency difference between the signal related to the selected one of the position signals and the reference clock signal. The circuit further includes a synchronization control processor coupled to receive the frequency difference value and configured to generate a synchronization selection signal. The circuit further includes a multiplexer having a first input node coupled to receive the signal related to the selected one of the position signals, a second input node coupled to receive the reference clock signal, a control node coupled to receive the synchronization control signal, and an output node at which is generated a multiplexer output signal comprised of either the signal related to the selected one of the position signals or the reference clock signal.

25 In accordance with another aspect of the present invention, a method of driving a multi-phase brushless DC motor, the motor having a motor shaft and a plurality of motor windings, includes generating a plurality of position signals. Each one of the plurality of position signals is representative of a rotational position of the motor shaft. The method further includes generating a frequency difference value related to a frequency difference between the signal related to the selected one of the position signals and the reference clock signal. The method further includes generating a synchronization selection signal in accordance with the frequency difference value. The method further includes generating, in accordance with the synchronization selection signal, a multiplexer output signal comprised of either the signal related to the selected one of the position signals or the reference clock signal.

BRIEF DESCRIPTION OF THE DRAWINGS

The foregoing features of the invention, as well as the invention itself may be more fully understood from the following detailed description of the drawings, in which:

FIG. 1 is a block diagram showing an exemplary motor control circuit having a plurality of modulation waveform generators and having a forced synchronization control, the motor control circuit coupled to an electric motor, the motor having Hall effect magnetic field sensing elements disposed therein to generate signals representative of an angle of rotation of the motor shaft;

FIG. 2 is a block diagram showing an exemplary modulation waveform generator that can be used as one of the modulation waveform generators in the circuit of FIG. 1;

FIG. 3 is a graph showing signal waveforms associated with the modulation waveform generator of FIG. 2;

FIG. 4 is a graph showing signal waveforms within the motor control circuit of FIG. 1, including signal waveforms associated with the plurality of modulation waveform generators of FIG. A;

FIG. 5 is a graph showing signal waveforms within a conventional motor control circuit, which has one modulation waveform generator;

FIG. 6 is a block diagram showing another exemplary motor control circuit having a plurality of modulation waveform generators and having a forced synchronization control, the motor control circuit coupled to an electric motor, the motor having a resolver disposed therein to generate signals representative of an angle of rotation of the motor shaft;

FIG. 7 is a block diagram showing another exemplary motor control circuit having a plurality of modulation waveform generators and having a forced synchronization control, the motor control circuit coupled to an electric motor, the motor control circuit having a back EMF detector coupled to the motor that can generate signals representative of an angle of rotation of the motor shaft; and

FIG. 8 is a block diagram of a multiplexed arrangement that can replace the plurality of modulation waveform generators of FIG. 1 with one modulation waveform generator used in a multiplexed arrangement.

#### DETAILED DESCRIPTION OF THE INVENTION

Before describing the present invention, some introductory concepts and terminology are explained. As used herein, the term “magnetic field sensing element” is used to describe a variety of electronic elements that can sense a magnetic field. The magnetic field sensing elements can be, but are not limited to, Hall effect elements, magnetoresistance elements, or magnetotransistors. As is known, there are different types of Hall effect elements, for example, a planar Hall element, a vertical Hall element, and a circular Hall element. As is also known, there are different types of magnetoresistance elements, for example, a giant magnetoresistance (GMR) element, an anisotropic magnetoresistance element (AMR), a tunneling magnetoresistance (TMR) element, an Indium antimonide (InSb) sensor, and a magnetic tunnel junction (MTJ).

As is known, some of the above-described magnetic field sensing elements tend to have an axis of maximum sensitivity parallel to a substrate that supports the magnetic field sensing element, and others of the above-described magnetic field sensing elements tend to have an axis of maximum sensitivity perpendicular to a substrate that supports the magnetic field sensing element. In particular, most types of magnetoresistance elements tend to have axes of maximum sensitivity parallel to the substrate and most types of Hall elements tend to have axes of sensitivity perpendicular to a substrate.

As used herein, the term “magnetic field sensor” is used to describe a circuit that includes a magnetic field sensing element. Magnetic field sensors are used in a variety of applications, including, but not limited to, a current sensor that senses a magnetic field generated by a current carried by a current-carrying conductor, a magnetic switch that senses the proximity of a ferromagnetic object, a rotation detector that senses passing ferromagnetic articles, for example, magnetic domains of a ring magnet, and a magnetic field sensor that senses a magnetic field density of a magnetic field.

As used herein, the term “signal” is used to describe an electronic characteristic, analog or digital, that tends to change rapidly. In contrast, as used herein, the term “value” is used to describe a digital electronic value that tends to be static, or the tends to change slowly or from time to time. However the terms signal and value can be used interchangeably.

Referring to FIG. 1, a motor drive arrangement 10 that includes an exemplary electronic circuit 12 coupled to an

electric motor 70 and to a Hall array 26, has a plurality of pins 12a-12l with respective functions and couplings described below.

Pin 12a, a regulated voltage pin (VREG), is coupled to receive a regulated voltage 66 from outside of the electronic circuit 12. The regulated voltage 66, or alternatively, a regulated current, is provided to the array of Hall effect elements 26. The regulated voltage 66 provides power to most of the circuitry three within the electronic circuit 12.

Pin 12b, a frequency reference pin (FREF), is coupled to receive a frequency reference signal 78 from outside of the electronic circuit 12. As described in greater detail below, functions of the electronic circuit 12 can be synchronized with the frequency reference signal 78.

Pins 12c-12e, Hall A, Hall B, and Hall C (HA, HB, HC) pins, are coupled to receive respective signals from Hall effect elements, which are magnetic field sensing elements, within the Hall array 26.

Pin 12f, a start pin (START), is coupled to receive a control signal from outside of the electronic circuit 12. The control signal can start and stop the functions of the electronic circuit 12, and therefore, start and stop the electric motor 70.

Pin 12g, a ground pin (GND), provides a power supply ground for the electronic circuit 12.

Pin 12h, a lower supply pin (LSS), is coupled to receive a lower power supply voltage from outside of the electronic circuit 12. The lower power supply is one of two voltages sent to the electric motor 70 in a pulse width modulated (PWM) arrangement described more fully below.

Pins 12k, 12j, 12i, motor drive signal pins (SA, SB, SB, respectively), are coupled to provide PWM drive signals 80, 82, 84, respectively, to the electric motor 70.

Pin 12l, an upper supply pin (VDD), is coupled to receive an upper power supply voltage from outside of the electronic circuit 12. The upper power supply is the other one of the two voltages sent to the electric motor 70 in the pulse width modulated (PWM) arrangement described more fully below.

It should be understood that the Hall array 26 is disposed in close proximity to the electric motor 70, but is shown here at a different position for clarity of the electronic circuit 12.

In operation of the motor control circuit 12, Hall effect elements within the Hall array 26, for example, three Hall effect elements, are positioned to sense magnetic fields, and, in particular, varying magnetic field, of magnets within the electric motor 70 as a shaft of the electric motor 70 rotates. In one particular embodiment, the three Hall effect elements 26 can be disposed at positions relative to the electric motor 70 that are one hundred twenty degrees apart about an axis of rotation of the shaft of the electric motor.

The three Hall effect elements within the Hall array 26 generate position signals 26a, 26b, 26c, which are received by a digital filter 28. The position signals 26a, 26b, 26c are generally analog signals, and each is representative of an angle of rotation of the shaft of the electric motor 70.

Conversion to digital signals is not shown in FIG. 1, but it is presumed that the position signals 26a-26c are either converted before the digital filter 28 or within the digital filter 28. The digital filter 28 is configured to generate filtered signals 28a, 28b, 28c, each of which is representative of a respective one of the position signals 26a, 26b, 26c. The filtered signals 28a, 28b, 28c can be, for example, multi-bit digital signals. The filtered signals 28a, 28b, 28c are also representative of the angle of rotation of the shaft of the electric motor 70.

A multiplexer 30 is coupled to receive the filtered signal 28a and configured to provide a signal 30a. At the beginning of operation of the electronic circuit 12, the multiplexer 30 is

switched to provide the signal **30a** to be the same as the filtered signal **28a**. Operation of the multiplexer **30** is described more fully below.

A so-called "trapezoid encoder" **32** is coupled to receive the signal **30a**, and also the filtered signals **28b**, **28c**. A trapezoid encoder will be understood to be a form of pattern generator and is also referred to as a pattern generator herein.

The trapezoid encoder **32** is configured to generate output signals **32a**, **32b**, **32c** (also referred to herein as pattern signals), which can be single bit square wave signals. In some embodiments the three output signals **32a**, **32b**, **32c** have phases one hundred twenty degrees apart. The trapezoid encoder **32** is also configured to generate signals **32d**, **32e**, **32f**. The output signals **32a-32f** are described more fully below in conjunction with FIGS. 2-4.

The electronic circuit **12** further includes a plurality of modulation waveform generators **34**, **36**, **38**, each coupled to receive a respective one of the output signals **32a**, **32b**, **32c** from the trapezoid encoder **32**. Operation of the modulation waveform generators **34**, **36**, **38** is described more fully below. Let it suffice here to say that the modulation waveform generators are configured to generate respective output signals **34a**, **36a**, **38a**, which are functioned signals, for example, triangle wave signals or sawtooth wave signals.

A clock generating circuit **62** provides a clock signal **62a** to each one of the modulation waveform generators **34**, **36**, **38**. The clock signal **62a** can also be provided to other portions of the electronic circuit **12**.

The electronic circuit **12** can also include a plurality of comparators **40**, **42**, **44**, each coupled to receive a respective one of the output signals **34a**, **36a**, **38a** from a respective one of the modulation waveform generators **34**, **36**, **38**. Each one of the plurality of comparators **40**, **42**, **46** is also coupled to receive a threshold value **24a**, shown here to be the same threshold value **24a**. However in other embodiments, each one of the comparators **40**, **42**, **44** can be coupled to receive a different respective threshold value.

The plurality of comparators **40**, **42**, **44** is configured to compare respective ones of the output signals **34a**, **36a**, **38a** from the plurality of modulation waveform generators **34**, **36**, **38** with the threshold value **24a** to generate a respective plurality of output signals **40a**, **42a**, **44a**, as pulse width modulated (PWM) signals.

Digital control logic **46** is coupled to receive the pulse width modulated signals **40a**, **42a**, **44a** and configured to generate preliminary drive signals **46a**, **46b**, **46c**.

A gate driver circuit **48** is coupled to receive the preliminary drive signals **46a**, **46b**, **46c** and configured to generate gate drive signals **48a-48f**. For clarity, only two of the gate drive signals are shown to be coupled, but the other couplings should be apparent.

Three high side field effect transistors (FETs) **50**, **52**, **54** are coupled to receive the gate drive signals **48a**, **48b**, **48c**, respectively, and three low side FETs **56**, **58**, **60** are coupled to receive the gate drive signals **48f**, **48e**, **48d**, (signals **172**, **170**, **168** of FIG. 4), respectively. The gate drive signals **48a-48f** cause the FETs **52-60** to operate in saturation with pulse width modulation, and thus, consume only a small amount of power.

The arrangement of the FETs **52-60** is configured to generate three drive signals **80**, **82**, **84**, which are coupled to ends of respective ones of windings **72**, **74**, **76** within the electric motor **70**. Other ends of the windings **72**, **74**, **76** can be coupled together.

The electronic circuit **12** can also include a frequency difference processor **14** coupled to receive the filtered signal **28a** and also coupled to receive the frequency reference sig-

nal **78** from outside of the electronic circuit **12**. The frequency difference processor **14** is configured to generate frequency difference values **14a**, **14b**, each having a magnitude representative of a frequency difference between the frequency reference signal **78** and the filtered signal **28a**.

The electronic circuit **12** can include a duty cycle calculation processor **16** coupled to receive the frequency difference value **14a** and configured to generate a duty cycle value **16a** having N bits and another duty cycle value **16b** having M bits, which can be considered together to be one digital word having M+N bits. The duty cycle value **16a** can be considered to be the lower order bits of the one digital word. In some embodiments M=8 and N=4. However, in other embodiments M can be greater than or less than eight, and N can be greater than or less than four.

The electronic circuit **12** can also include a dithering processor **18** coupled to receive the duty cycle value **16a** and configured to generate a one bit dithered value **18a** having a dithering characteristic. Dithering will be understood to be a technique used in a variety of applications that can translate a value, for example, the duty cycle value **16a**, into an occurrence rate of the dithered value **18a**, e.g., a one versus a zero. Dithering is most often used to result in a reduction of a number of required bits in a digital word in an application, while still achieving the same ultimate resolution in the application as that which would be achieved without reducing the number of required bits.

In other embodiments, the dithered value **18a** can have more than one bit. However, generally speaking, the desired value **18a** has fewer bits than the duty cycle value **16a**.

The electronic circuit **12** can also include a combining processor **24** coupled to receive the dithered value **18a** having one bit, coupled to receive the duty cycle value **16b** having M bits, and configured to combine the values to generate a dithered value **24a** having M+1 bits.

It will be understood that the dithered value **24a**, which has M+1 bits, results in substantially the same system resolution as a combination of the duty cycle values **16a**, **16b**, which together have M+N bits. However, if instead, the electronic circuit **12** used the combination of the duty cycle values **16a**, **16b** having M+N bits, various parts of the electronic circuit **12** would need to operate at a faster clock rate. The faster clock rate would result in substantially more power consumed by the electronic circuit **12**.

The electronic circuit **12** can also include a phase difference processor **20** coupled to receive the filtered signal **28a** and also coupled to receive the frequency reference signal **78** from outside of the electronic circuit **12**. The phase difference processor **20** is configured to generate a phase difference value **20a** having a magnitude representative of a phase difference between the frequency reference signal **78** and the filtered signal **28a**.

The electronic circuit **12** can also include a force synchronization control processor **22** coupled to receive the frequency difference signal **14b**, (optionally) coupled to receive the phase difference signal **20a**, and configured to generate a selection signal **22a**. The selection signal **22a** is received by the multiplexer **30**. The multiplexer **30** is also coupled to receive the frequency reference signal **78** from outside of the electronic circuit **12**. The selection signal **22a** selects which one of the frequency reference signal **78** or the filtered signal **28a** passes through the multiplexer **30** to generate the signal **30a**.

In operation, when first powered up, the electronic circuit **12** operates with the multiplexer **30** selected to provide the filtered signal **28a** as the signal **30a**.

Using the filtered signal **28a** results in the electric motor **70**, and, in particular, a shaft of the electric motor **70**, turning faster and faster.

As the motor **70** spins faster and faster, a frequency of the filtered signal **28a** approaches the frequency of the frequency reference signal **78**. Accordingly, the frequency difference value **14b** becomes smaller and smaller, approaching zero. Similarly, the phase difference value **20a** eventually becomes smaller and smaller, approaching zero.

In some embodiments, when the frequency difference value **14b** is above a frequency difference threshold value, the multiplexer output signals **30a** is the same as or similar to the filtered signal **28a**, which is representative of the position signal **26a**. Conversely, when the frequency difference value **14b** is below the frequency difference threshold value, the multiplexer output signal **30a** is the same as or similar to the frequency reference signal **78**, a reference clock signal.

In some other embodiments, when the frequency difference value **14b** is above the frequency difference threshold value and when the phase different value **20a** is above a phase difference threshold value, the multiplexer output signals **30a** is the same as or similar to the filtered signal **28a**. Conversely, when the frequency difference value **14b** is below the frequency difference threshold and when the phase difference value **20a** is below the phase different threshold value, the multiplexer output signal **30a** is the same as or similar to the frequency reference signal **78**, a reference clock signal.

Thus, in some embodiments, the phase difference processor **20** is not part of the electronic circuit **12**.

With the above arrangements, it will be appreciated that electronic circuit **12** first powers up and attempts to run the motor faster and faster based upon the filtered signals **28a**, **28b**, **28c**. However, when the frequency of the filtered signal **28a** is sufficiently close to the frequency of the frequency reference signal **78**, the electronic circuit **12** switches operation such that the signals **32a**, **32b**, **32c** generated by the trapezoid encoder **32** must have exactly the same frequency as the frequency reference signal **78**.

In general, it should be understood that a phase lock loop or frequency locked loop provided by other circuits does not and cannot generate a perfectly stable output frequency. Each one of these loops operates by way of an error signal that is subject to electrical noise and other disturbances. In contrast, the electronic circuit **12** forces the signals **32a**, **32b**, **32c** to be at the same frequency as the frequency reference signal **78**. The electronic circuit **12** has no feedback path and does not constitute a frequency locked loop or a phase locked loop. In other words, the electronic circuit **12** causes a so-called "forced" synchronization to the frequency reference signal **78**.

Further operation of the electronic circuit **12**, and, in particular, of the plurality of modulation waveform generators **34**, **36**, **38**, is described more fully below in conjunction with FIGS. 2-4.

While a trapezoidal encoder **32**, a type of pattern generator, is shown, it should be recognized that there are other forms of pattern generators that may be suitable, including, but not limited to, state generators.

While three signal channels corresponding to the three pulse width modulation signals **40a**, **42a**, **44a** are shown, it should be understood that, in other embodiments, there can be more than three or two signal channels. The number of signal channels is generally selected in accordance with a number of position signals, e.g., **26a**, **26b**, **26c**.

Referring now to FIG. 2, an exemplary modulation waveform generator **102** is shown in conjunction with an exemplary comparator **112** in a combining circuit **100**. The modu-

lation waveform generator **102** can be the same as or similar to one of the modulation waveform generators **34**, **36**, **38** of FIG. 1. The comparator **112** can be the same as or similar to one of the comparators **40**, **42**, **44** of FIG. 1.

The modulation waveform generator **102** is coupled to receive a clock signal **116**. The clock signal **116** can be the same as or similar to the clock signal **62a** of FIG. 1. The modulation waveform generator **102** is also coupled to receive a signal **114** at a reset input **102a**. The signal **114** can be the same as or similar to one of the pattern signals **32a**, **32b**, **32c** of FIG. 1.

In the exemplary modulation waveform generator **102**, the clock signal **116** is received at a clock input to an up/down counter **104**. A high comparator **106** and a low comparator **108** are coupled to receive the count signal **104a**, which can be a multi-bit digital signal, from the up down counter **104**. The high comparator **106** is configured to provide a high comparison signal **106a** and the low comparator **108** is configured to provide a low comparison signal **108a**. The high comparison signal **106a** and the low comparison signal **108a** can be coupled to set and reset inputs, respectively, of a set-reset flip-flop **110**. The set-reset flip-flop **110** can provide an up/down direction signal **110a** to control the direction of the counting of the up/down counter **104**. Thus, it will be recognized that the count signal **104a** counts up and then down to generate a triangular signal **104a**.

The comparator **112** can be coupled to receive the triangle signal **104a**. The comparator **112** can also be coupled to receive a threshold value **120**. The threshold value **120** can be the same as or similar to the dithered signal **24a** of FIG. 1. The threshold value **120** is generally a fairly static digital signal having a threshold value that can be dithered from time to time in its lower order bits as is apparent from the architecture of FIG. 1.

In operation, the comparator **112** compares the triangle waveform **104a** with the threshold value **120**, resulting in a comparison signal **112a**. The comparison signal can be the same as or similar to one of the comparison signals **40a**, **42a**, **44a** of FIG. 1.

It will be understood that, by changing the value of the threshold value **120**, the comparison signal **112a** will have a changing duty cycle. Such change will become more apparent from discussion below in conjunction with FIG. 3.

Referring now to FIG. 3, a graph **140** has a plurality of horizontal axes, each with a scale in units of time in arbitrary units. The graph **140** also has a vertical axis with a scale in units of volts in arbitrary units.

A signal **142** can be the same as or similar to the pattern signal **114** of FIG. 2. The signal **142** can have low states **142b** and high states **142a**.

A signal **144** can be the same as or similar to the triangle waveform **104a** of FIG. 2. The triangle waveform **144** has active regions, of which an active region **144a** is an example, and inactive regions, of which an inactive region **144b** is an example. The active regions align with high states of the pattern signal **142**.

A threshold value **146**, here shown without dithering that would otherwise cause slight occasional perturbations of the threshold value **146**, can be the same as or similar to the threshold value **120** of FIG. 2.

A signal **148** can be the same as or similar to the comparison signal **112a** of FIG. 2. The signal **148** can include active regions, of which an active region **148a** is an example, and inactive regions, of which a region **148b** is an example. The signal **148** is generated by comparison of the signal **144** with the threshold value **146**. It should be appreciated that a duty cycle of the signal **148** can be influenced by a value of the

threshold value **146**. Thus, the combining circuit **100** of FIG. **2** can be used to generate the signal **148** as a PWM waveform.

Inspection of the circuit **10** of FIG. **1** will also show that the duty cycle of the PWM waveform (signals **40a**, **42a**, **44a**) is influenced by the duty cycle calculation processor **16**, which is influenced by the frequency difference processor **14**. Thus, the PWM signal **148** tends to have a higher percentage duty cycle (and drive the electric motor **70** harder) if the motor is going too slow, as represented by a frequency of the filtered signal **28a**, in relation to the frequency reference signal **78**.

Further operation of the electronic circuit of FIG. **1** is described below in conjunction with FIG. **4**.

Referring now to FIG. **4**, a graph **160** has a plurality of horizontal axes with scales in units of time in arbitrary units. The graph **160** also includes a vertical axis with a scale in units of voltage.

A signal **162** can be the same as or similar to the signal **142** of FIG. **3**, the same as or similar to the signal **114** of FIG. **2**, and the same as or similar to the one of the signals **32a**, **32b**, **32c** of FIG. **1**, for example, the signal **32a**. A signal **164** can also be the same as or similar to the signal **142** of FIG. **3**, the same as or similar to the signal **114** of FIG. **2**, and the same as or similar to another one of the signals **32a**, **32b**, **32c** of FIG. **1**, for example, the signal **32b**. A signal **164** can also be the same as or similar to the signal **142** of FIG. **3**, the same as or similar to the signal **114** of FIG. **2**, and the same as or similar to another one of the signals **32a**, **32b**, **32c** of FIG. **1**, for example, the signal **32b**.

The signals **162**, **164**, **166** are related to the upper FETs **50**, **52**, **54** of FIG. **1**. Signals **168**, **170**, **172** are related to the lower FETs **56**, **58**, **60** of FIG. **1**. The signals **168**, **170**, **172** are described more fully below. The signals **168**, **170**, **172** can be the same as or similar to the signals **32d**, **32e**, **32f** of FIG. **1**.

A signal **176** can be the same as or similar to the signal **144** of FIG. **3**, the same as or similar to the signal **104a** of FIG. **2**, and the same as or similar to one of the signals **34a**, **36a**, **38a** of FIG. **1**, for example, the signal **34a**. A signal **180** can be the same as or similar to the signal **144** of FIG. **3**, the same as or similar to the signal **104a** of FIG. **2**, and the same as or similar to another one of the signals **34a**, **36a**, **38a** of FIG. **1**, for example, the signal **36a**. A signal **184** can be the same as or similar to the signal **144** of FIG. **3**, the same as or similar to the signal **104a** of FIG. **2**, and the same as or similar to another one of the signals **34a**, **36a**, **38a** of FIG. **1**, for example, the signal **38a**.

Threshold values **186**, **188**, **190**, which can be the same threshold value, can be the same as or similar to the threshold value **146** of FIG. **3**, the same as or similar to the threshold value **120** of FIG. **2**, and the same as or similar to the threshold value **24a** of FIG. **1**. Dithering is not shown in the threshold values **186**, **188**, **190**, **146**, or **120**.

A signal **174** can be the same as or similar to the signal **148** of FIG. **3**, the same as or similar to the signal **112a** of FIG. **2**, and the same as or similar to one of the signals **40a**, **42a**, **44a** of FIG. **1**, for example, the signal **40a**. A signal **178** can be the same as or similar to the signal **148** of FIG. **3**, the same as or similar to the signal **112a** of FIG. **2**, and the same as or similar to another one of the signals **40a**, **42a**, **44a** of FIG. **1**, for example, the signal **42a**. A signal **182** can be the same as or similar to the signal **148** of FIG. **3**, the same as or similar to the signal **112a** of FIG. **2**, and the same as or similar to another one of the signals **40a**, **42a**, **44a** of FIG. **1**, for example, the signal **44a**. The signals **174**, **178**, **180** are generated by comparing the signals **176**, **180**, **184** with the respective threshold values **186**, **188**, **190**, respectively.

It should be appreciated that duty cycles of the signals **174**, **178**, **182** can be influenced by values of the threshold values **186**, **188**, **190**. Thus, the signals **174**, **178**, **182** are representative of PWM signals

As described above in conjunction with FIG. **3**, the duty cycle of the PWM waveforms **174**, **178**, **182** is influenced by the duty cycle calculation processor **16**, which is influenced by the frequency difference processor **14**. Thus, the PWM signal **148** tends to have a higher percentage duty cycle (and drive the electric motor **70** harder) if the motor is going too slow, as represented by a frequency of the filtered signal **28a**, in relation to the frequency reference signal **78**.

Referring again to the signals **168**, **170**, **172**, those signals are representative of closures (e.g., connections to ground) of the lower FETs of FIG. **1** by way of the signals **32d**, **32e**, **32f** of FIG. **1** in timing relations to the PWM signals **174**, **178**, **182** applied to the upper FETs.

Further inspection of the signals **176**, **180**, **184** shows that the triangle waves essentially restart (have the same starting phase) during each instance of active regions of the signals **176**, **180**, **184**. As a result, each one of the PWM signals **174**, **178**, **182** also has the same starting phase and the same starting signal value. This can result in each one of the PWM signals **174**, **178**, **182** being the same within their respective active regions and the same within each active region once the motor speed has stabilized. Thus, each one of the PWM signals **174**, **178**, **182** has no phase jitter from active region to active region. Such a result is achieved by using a separate modulation waveform generators (**34**, **36**, **38** of FIG. **1**) for each one of the three signal channels. However, the same result can also be achieved using one modulation waveform generator used in a plurality of signal channels in ways described more fully below.

A time period, **p1**, is a time period of one rotation of the electric motor **70** of FIG. **1**. The time period, **p1**, is also the sum of the time periods **t2-t1**, **t3-t2**, and **t4-t3**, which are the periods of the signal **162**, **164**, **166**, respectively, and also the periods of the signals **174** and **176**, **178** and **180**, **182** and **184**, respectively.

As will be understood from the discussion above in conjunction with FIG. **1**, the PWM signals **174**, **178**, **182** are representative of the signals **80**, **82**, **84** of FIG. **1**, which drive the electric motor **70**. The precise cycle period matches, and the consistency of those cycle periods for each rotation cycle of the electric motor **70**, results in the motor **70** having very little jitter in rotation speed.

Referring now to FIG. **5**, a graph **200** has a plurality of horizontal axes with scales in units of time in arbitrary units. The graph **200** also includes a vertical axis with a scale in units of voltage. The graph **200** is representative of signal generated within a conventional motor control circuit. Notably, the conventional motor control circuit has one modulation waveform generator and one comparator, forming one signal channel, in contrast to the present invention, which has a plurality of signal channels. To this end, the conventional motor control circuit generates one continuous triangle wave signal **208**. A threshold value **210** is compared with the triangle wave signal **208** to generate PWM signals **202**, **204**, **208**, duty cycles of which are influenced by the value of the threshold value **210**.

It should be apparent that cycles of the triangle wave signal **200** are not synchronous with rotational periods, **p1a**, **p2a**, of the electric motor **70** of FIG. **1**.

In the conventional motor drive circuit, signals different from the signal **80**, **82**, **84** (FIG. **1**) drive the electric motor. The PWM signals **202**, **204**, **206** are representative of the signals that drive the electric motor. It can be seen that in a first



## 11

cycle, *p1a*, of rotation of the electric motor, the PWM signals **202**, **204**, **206** have PWM characteristics that are not the same as during a next cycle, *p2a*, of rotation of the electric motor. These differences tend to result in jitter in the rotation of the electric motor, which is avoided with the present invention.

FIGS. **5** and **6** are provided to show that rotational position of the electric motor **70** of FIG. **1** can be detected in ways other than using the Hall array **26** of FIG. **1**.

Referring now to FIG. **6**, a motor control arrangement includes a motor control circuit **252** coupled to the electric motor **70** and to a resolver **254**. A resolver is known in the art of electric motors. The resolver provides sine and cosine signals **254a**, **254b**, respectively, which can be received by a resolver to state encoder **256** within the motor control circuit **252** to generate three signals **256a**, **256b**, **256c**. The three signals **256a**, **256b**, **256c**, each representative of a rotational position of the shaft of the electric motor **70**, are similar to the signals **28a**, **28b**, **28c** of FIG. **1**. Thus, operation of the rest of the motor drive circuit **252** is the same as or similar to operation of similar portions of the motor drive circuit **12** of FIG. **1**, and is not further discussed.

Referring now to FIG. **7**, a motor control arrangement **270** includes a motor control circuit **272** coupled to the electric motor **70**. The electric motor **70** can provide "back EMF" signals **70a**, **70b**, **70c**, which can be received by a back EMF to state encoder **274** within the motor control circuit **272** to generate three signals **274a**, **274b**, **274c**. The three signals **274a**, **274b**, **274c**, each representative of a rotational position of the shaft of the electric motor **70**, are similar to the signals **28a**, **28b**, **28c** of FIG. **1**. Thus, operation of the motor drive circuit **272** is the same as or similar to operation of similar portions of the motor drive circuit **12** of FIG. **1**, and is not further discussed.

Referring now to FIG. **8**, in which like elements of FIG. **1** are shown having like reference designations, a multiplexed arrangement **300** can replace the three modulation waveform generators **34**, **36**, **38** and the three comparators **40**, **42**, **44** of FIG. **1** with one modulation waveform generator **304** and one comparator **306**, but used in a multiplexed arrangement to form a plurality of signal channels. The modulation waveform generator **304** can be the same as or similar to the waveform modulation generator **102** of FIG. **2**.

Referring briefly to FIG. **4**, it can be seen that the triangle waveform signals **176**, **180**, **184** are generated at different times with no overlap. Importantly, each one of the triangle waveform signals **176**, **180**, **184** begins at the same point (e.g., from zero) during each one of the periods *t2-t1*, *t3-t2*, *t4-t3*, respectively. In other words, at the beginning of each one of the periods *t2-t1*, *t3-t2*, *t4-t3*, a respective one of the modulation waveform generators **34**, **36**, **38** of FIG. **1** is allowed to run by a high state of a respective pattern signal **32a**, **32b**, **32c** (see also the reset signal **114** of FIG. **2** and signals **162**, **164**, **166** of FIG. **4**), and it is reset by a low state of a respective pattern signal **32a**, **32b**, **32c** at other times.

Referring again to FIG. **8**, combining logic **302** can be coupled to receive the pattern signals **32a**, **32b**, **32c** of FIG. **1**. The combining logic **302** is configured to generate a reset signal **302a**. The reset signal **302a** is received by the modulation waveform generator **304**.

In operation, the reset signal **302a** is configured to reset the modulation waveform generator **304** at the beginning of each one of the periods *t2-t1*, *t3-t2*, *t4-t3* of FIG. **4**, i.e., at particular transitions of the pattern signals **32a**, **32b**, **32c**. In some embodiments, the reset signal **302a** can be comprised of very short reset pulses at the appropriate times. The resets are operable to cause the modulation waveform generator **304** to restart upon each reset pulse. In one particular embodiment,

## 12

rising edges of the signals **32a**, **32b**, **32c** (i.e., signals **162**, **164**, **166** of FIG. **4**) can be logically ORed to generate reset pulses. However, other techniques to generate reset pulse are also possible.

The modulation waveform generator **304** is also coupled to receive the clock signal **62a** of FIG. **1**. The modulation waveform generator **304** is configured to generate a triangle wave output signal **304a** on one signal channel. The triangle wave output signal **304a** is like the signals **176**, **180**, **184** of FIG. **4**, but sequentially, one after the other, on the one signal channel, each restarting in accordance with a transition of one of the pattern signals **32a**, **32b**, **32c**.

A comparator **306** is coupled to receive the triangle wave output signal **304a**, coupled to receive the threshold value **24a** of FIG. **1**, and configured to generate a comparison signal **306a**. The comparison signal **306a** is like the signals **174**, **178**, **182** of FIG. **4**, but sequentially, one after the other, on one signal channel.

A 1:3 multiplexer **308** can be coupled to receive the comparison signal **306a**. The 1:3 multiplexer **308** can also be coupled to receive a control signal **302b** from the combining logic **302**. The 1:3 multiplexer **308**, by control of the control signal **302b**, separates (or splits) the comparison signal **306a** into generate three separate output signals **308a**, **308b**, **308c** on three separate signal channels. The three output signals **308a**, **308b**, **308c** can be the same as or similar to the three comparison signals **174**, **178**, **180** to of FIG. **4**, and the same as or similar to the three comparison signals **40a**, **42a**, **44a** of FIG. **1**.

While three signal channels corresponding to the three pulse width modulation signals **308a**, **308b**, **308c** are shown, it should be understood that, in other embodiments, there can be more than three or two signal channels. The number of signal channels is generally selected in accordance with a number of position signals, e.g., **26a**, **26b**, **26c** (FIG. **1**).

Operation of the multiplexed arrangement **300** will be apparent from the discussion above in conjunction with FIGS. **1-4**.

It should be understood that the forced synchronization provided by certain circuits within motor control circuits described herein and the plurality of signal channels provided by other certain circuits within the motor control circuits described here, both provide a reduced amount of jitter in the speed of rotation of the shaft of the electric motor. Other embodiments can provide only the force synchronization or only the plurality of signal channels. Furthermore, in other embodiments, the dithering described herein is not used.

All references cited herein are hereby incorporated herein by reference in their entirety. Having described preferred embodiments, which serve to illustrate various concepts, structures and techniques, which are the subject of this patent, it will now become apparent to those of ordinary skill in the art that other embodiments incorporating these concepts, structures and techniques may be used. Accordingly, it is submitted that that scope of the patent should not be limited to the described embodiments but rather should be limited only by the spirit and scope of the following claims.

What is claimed is:

**1.** A circuit for driving a multi-phase brushless DC motor, the motor having a motor shaft and a plurality of motor windings, the circuit comprising:

a position signal generator configured to generate a plurality of position signals, each one of the plurality of position signals representative of a rotational position of the motor shaft;

a frequency difference processor coupled to receive a signal related to a selected one of the position signals,

## 13

coupled to receive a reference clock signal, and configured to generate a frequency difference value related to a frequency difference between the signal related to the selected one of the position signals and the reference clock signal;

a synchronization control processor coupled to receive the frequency difference value and configured to generate a synchronization selection signal; and

a multiplexer having a first input node coupled to receive the signal related to the selected one of the position signals, a second input node coupled to receive the reference clock signal, a control node coupled to receive the synchronization control signal, and an output node at which is generated a multiplexer output signal comprised of either the signal related to the selected one of the position signals or the reference clock signal.

2. The circuit of claim 1, wherein, when the frequency difference value is above a frequency difference value threshold, the multiplexer output signal is related to the selected one of the position signals, and when the frequency difference value is below the frequency difference value threshold, the multiplexer output signal is related to the reference clock signal.

3. The circuit of claim 1, further comprising:

a phase difference processor coupled to receive the signal related to the selected one of the position signals, coupled to receive the reference clock signal, and configured to generate a phase difference value related to a phase difference between the signal related to the selected one of the position signals and the reference clock signal, wherein the synchronization control processor is further coupled to receive the phase difference value.

4. The circuit of claim 3, wherein, when the phase difference value is above a phase difference value threshold, the multiplexer output signal is related to the selected one of the position signals, and when the phase difference value is below the phase difference value threshold, the multiplexer output signal is related to the reference clock signal.

5. The circuit of claim 3, wherein, when the frequency difference value is above a frequency difference value threshold and the phase difference value is above the phase difference value threshold, the multiplexer output signal is related to the selected one of the position signals, and when the frequency difference value is below the frequency difference value threshold and the phase difference value is below the phase difference value threshold, the multiplexer output signal is related to the reference clock signal.

6. The circuit of claim 5, further comprising:

a pattern generator coupled to receive the multiplexer output signal, coupled to receive selected ones of the plurality of position signals, and configured to generate a plurality of pattern signals, each pattern signal a predetermined number of degrees apart from other ones of the plurality of pattern signals, each one of the pattern signals having respective first and second states;

a modulation circuit coupled to receive the plurality of pattern signals and configured to generate a corresponding plurality of pulse width modulated (PWM) signals, each one of the plurality of pulse width modulated signals having a respective active region comprising a pulse width modulated waveform only during a selected one of the first or second states of a respective one of the plurality of pattern signals; and

a plurality of drive circuits coupled to receive a plurality of signals representative of the plurality of pulse width modulated signals, wherein the plurality of drive circuits

## 14

is configured to generate a plurality of drive signals related to the plurality of pulse width modulated signals, each one of the plurality of drive signals configured to couple to one end of a respective one of the plurality of motor windings.

7. The circuit of claim 1, further comprising:

a pattern generator coupled to receive the multiplexer output signal, coupled to receive selected ones of the plurality of position signals, and configured to generate a plurality of pattern signals, each pattern signal a predetermined number of degrees apart from other ones of the plurality of pattern signals, each one of the pattern signals having respective first and second states;

a modulation circuit coupled to receive the plurality of pattern signals and configured to generate a corresponding plurality of pulse width modulated (PWM) signals, each one of the plurality of pulse width modulated signals having a respective active region comprising a pulse width modulated waveform only during a selected one of the first or second states of a respective one of the plurality of pattern signals; and

a plurality of drive circuits coupled to receive a plurality of signals representative of the plurality of pulse width modulated signals, wherein the plurality of drive circuits is configured to generate a plurality of drive signals related to the plurality of pulse width modulated signals, each one of the plurality of drive signals configured to couple to one end of a respective one of the plurality of motor windings.

8. The circuit of claim 7, wherein the modulation circuit comprises:

a plurality of modulation waveform generators, each one of the plurality of modulation waveform generators coupled to receive a respective one of the plurality of pattern signals, wherein the plurality of modulation waveform generators is configured to generate a plurality of function signals, wherein active portions of each one of the plurality of function signals are generated only during a selected state of a respective one of the pattern signals; and

a plurality of comparators, each one of the plurality of comparators coupled to receive a respective one of the plurality of function signals, and each one of the plurality of comparators coupled to receive a respective threshold value, wherein each one of the plurality of comparators is configured to compare the respective one of the plurality of function signals with the respective threshold value to generate a respective one of the plurality of pulse width modulated (PWM) signals having a duty cycle generated in accordance with the respective threshold value.

9. The circuit of claim 8, further comprising a dithering processor configured to generate each respective threshold value as a dithered value.

10. The circuit of claim 7, wherein the modulation circuit comprises:

combining logic coupled to receive the plurality of pattern signals and configured to generate a reset signal having state transitions that occur at state transitions of each one of the plurality of pattern signals;

a modulation waveform generator coupled to receive the reset signal and configured to generate a function signal, wherein active portions of the function signals are generated only during a selected state of the plurality of pattern signals, wherein the function signal is reset to a predetermined condition in accordance with the transitions of the reset signal;

## 15

a comparator coupled to receive the function signal, coupled to receive a threshold value, and configured to compare the function signal with the threshold value to generate a pulse width modulated (PWM) signal having a duty cycle generated in accordance with the threshold value; and

a multiplexer coupled to receive the pulse width modulated signal and configured to split the pulse width modulated signal into a plurality of different portions, each portion carried on a separate respective signal channel.

**11.** The circuit of claim **10**, further comprising a dithering processor configured to generate the threshold value as a dithered value.

**12.** A method of driving a multi-phase brushless DC motor, the motor having a motor shaft and a plurality of motor windings, the method comprising:

generating a plurality of position signals, each one of the plurality of position signals representative of a rotational position of the motor shaft;

generating a frequency difference value related to a frequency difference between the signal related to the selected one of the position signals and the reference clock signal;

generating a synchronization selection signal in accordance with the frequency difference value; and

generating, in accordance with the synchronization selection signal, a multiplexer output signal comprised of either the signal related to the selected one of the position signals or the reference clock signal.

**13.** The method of claim **12**, wherein, when the frequency difference value is above a frequency difference value threshold, the multiplexer output signal is related to the selected one of the position signals, and when the frequency difference value is below the frequency difference value threshold, the multiplexer output signal is related to the reference clock signal.

**14.** The method of claim **12**, further comprising: generating a phase difference value related to a phase difference between the signal related to the selected one of the position signals and the reference clock signal.

**15.** The method of claim **14**, wherein, when the phase difference value is above a phase difference value threshold, the multiplexer output signal is related to the selected one of the position signals, and when the phase difference value is below the phase difference value threshold, the multiplexer output signal is related to the reference clock signal.

**16.** The method of claim **14**, wherein, when the frequency difference value is above a frequency difference value threshold and the phase difference value is above the phase difference value threshold, the multiplexer output signal is related to the selected one of the position signals, and when the frequency difference value is below the frequency difference value threshold and the phase difference value is below the phase difference value threshold, the multiplexer output signal is related to the reference clock signal.

**17.** The method of claim **16**, further comprising: generating a plurality of pattern signals, each pattern signal a predetermined number of degrees apart from other ones of the plurality of pattern signals, each one of the pattern signals having respective first and second states;

## 16

generating a corresponding plurality of pulse width modulated (PWM) signals, each one of the plurality of pulse width modulated signals having a respective active region comprising a pulse width modulated waveform only during a selected one of the first or second states of a respective one of the plurality of pattern signals; and generating a plurality of drive signals related to the plurality of pulse width modulated signals, each one of the plurality of drive signals configured to couple to one end of a respective one of the plurality of motor windings.

**18.** The method of claim **12**, further comprising:

generating a plurality of pattern signals, each pattern signal a predetermined number of degrees apart from other ones of the plurality of pattern signals, each one of the pattern signals having respective first and second states; generating a corresponding plurality of pulse width modulated (PWM) signals, each one of the plurality of pulse width modulated signals having a respective active region comprising a pulse width modulated waveform only during a selected one of the first or second states of a respective one of the plurality of pattern signals; and generating a plurality of drive signals related to the plurality of pulse width modulated signals, each one of the plurality of drive signals configured to couple to one end of a respective one of the plurality of motor windings.

**19.** The method of claim **18**, wherein the generating the plurality of pulse width modulated (PWM) signals comprises:

generating a plurality of function signals, wherein active portions of each one of the plurality of function signals are generated only during a selected state of a respective one of the pattern signals; and

comparing the respective one of the plurality of function signals with a respective threshold value to generate a respective one of the plurality of pulse width modulated (PWM) signals having a duty cycle generated in accordance with the respective threshold value.

**20.** The method of claim **19**, further comprising generating each respective threshold value as a dithered value.

**21.** The method of claim **18**, wherein the generating the plurality of pulse width modulated (PWM) signals comprises:

generating a reset signal having state transitions that occur at state transitions of each one of the plurality of pattern signals;

generating a function signal, wherein active portions of the function signals are generated only during a selected state of the plurality of pattern signals, wherein the function signal is reset to a predetermined condition in accordance with the transitions of the reset signal;

comparing the function signal with the threshold value to generate a pulse width modulated (PWM) signal having a duty cycle generated in accordance with the threshold value; and

splitting the pulse width modulated signal into a plurality of different portions, each portion carried on a separate respective signal channel.

**22.** The method of claim **21**, further comprising generating the threshold value as a dithered value.

UNITED STATES PATENT AND TRADEMARK OFFICE  
**CERTIFICATE OF CORRECTION**

PATENT NO. : 8,638,053 B2  
APPLICATION NO. : 13/278458  
DATED : January 28, 2014  
INVENTOR(S) : Chee-Kiong Ng

Page 1 of 1

It is certified that error appears in the above-identified patent and that said Letters Patent is hereby corrected as shown below:

In the Specification

Column 3, line 63 delete “or the tends” and replace with --or that tends--.

Column 4, Line 31 delete “(SA, SB, SB,” and replace with --(SA, SB, SC,--.

Column 5, line 33 delete “40, 42, 46” and replace with --40, 42, 44--.

Column 7, line 20 delete “different” and replace with --difference--.

Column 7, line 25 delete “different” and replace with --difference--.

Column 11, line 16 delete “56a, 256b, 256c,” and replace with --256a, 256b, 256c,--.

Column 12, line 24 delete “306a into generate” and replace with --306a to generate--.

Column 12, line 27 delete “180 to of FIG. 4,” and replace with --180 of FIG. 4,--.

Signed and Sealed this  
Twenty-ninth Day of September, 2015



Michelle K. Lee  
*Director of the United States Patent and Trademark Office*