

US008633477B2

(12) **United States Patent**
Lee et al.

(10) **Patent No.:** **US 8,633,477 B2**
(45) **Date of Patent:** **Jan. 21, 2014**

(54) **ORGANIC LIGHT-EMITTING DIODE
THREE-DIMENSIONAL IMAGE DISPLAY
DEVICE**

(58) **Field of Classification Search**
None
See application file for complete search history.

(75) Inventors: **Sung-Jung Lee**, Incheon (KR);
Min-Jung Kim, Incheon (KR);
Kyo-Hyeon Lee, Incheon (KR)

(56) **References Cited**

U.S. PATENT DOCUMENTS

5,822,117	A *	10/1998	Kleinberger et al.	359/465
6,437,915	B2 *	8/2002	Moseley et al.	359/465
2001/0013971	A1 *	8/2001	Kleinberger et al.	359/465
2005/0258771	A1 *	11/2005	Kang et al.	315/169.1
2005/0286126	A1 *	12/2005	Huang et al.	359/465
2007/0097024	A1 *	5/2007	Jung et al.	345/32
2008/0007566	A1 *	1/2008	Park et al.	345/606
2008/0165296	A1 *	7/2008	Kim et al.	349/15
2011/0149018	A1 *	6/2011	Kroll et al.	348/40

(73) Assignee: **Pavoninekorea Inc.**, Incheon (KR)

(*) Notice: Subject to any disclaimer, the term of this patent is extended or adjusted under 35 U.S.C. 154(b) by 399 days.

FOREIGN PATENT DOCUMENTS

KR	1020050013430	2/2005
KR	1020060130361	12/2006
KR	1020070038974	4/2007
KR	1020070046240	5/2007
KR	1020080004618	7/2008

(21) Appl. No.: **13/054,592**

(22) PCT Filed: **Jul. 15, 2009**

(86) PCT No.: **PCT/KR2009/003903**

§ 371 (c)(1),
(2), (4) Date: **Jan. 18, 2011**

* cited by examiner

(87) PCT Pub. No.: **WO2010/008208**

PCT Pub. Date: **Jan. 21, 2010**

Primary Examiner — Hrayr A Sayadian

(74) *Attorney, Agent, or Firm* — IPLA P.A.; James E. Bame

(65) **Prior Publication Data**

US 2011/0121327 A1 May 26, 2011

(57) **ABSTRACT**

Disclosed herein is an organic light-emitting diode three-dimensional image display device which comprises a first substrate, a cathode formed on the first substrate, an electron injection layer formed on the cathode, an electron transfer layer formed on the electron injection layer, an emission layer formed on the electron transfer layer, a hole transfer layer formed on the emission layer, a hole injection layer formed on the hole transfer layer, an anode formed on the hole injection layer, a wire grid polarizer formed on the anode and composed of a metal thin film pattern formed at a first angle and a method thin film pattern formed at a second angle perpendicular to the first angle, which are alternately arranged, and a second substrate arranged on the wire grid polarizer.

(30) **Foreign Application Priority Data**

Jul. 17, 2008 (KR) 10-2008-0069669
Jul. 8, 2009 (KR) 10-2009-0062302

(51) **Int. Cl.**
H01L 51/44 (2006.01)

(52) **U.S. Cl.**
USPC **257/40**; 257/88; 257/E51.022; 359/44;
359/462; 359/465; 349/15; 349/96; 349/117;
349/119; 348/51; 348/58; 348/E13.026; 345/87;
345/419; 353/7; 353/8; 353/121

3 Claims, 6 Drawing Sheets

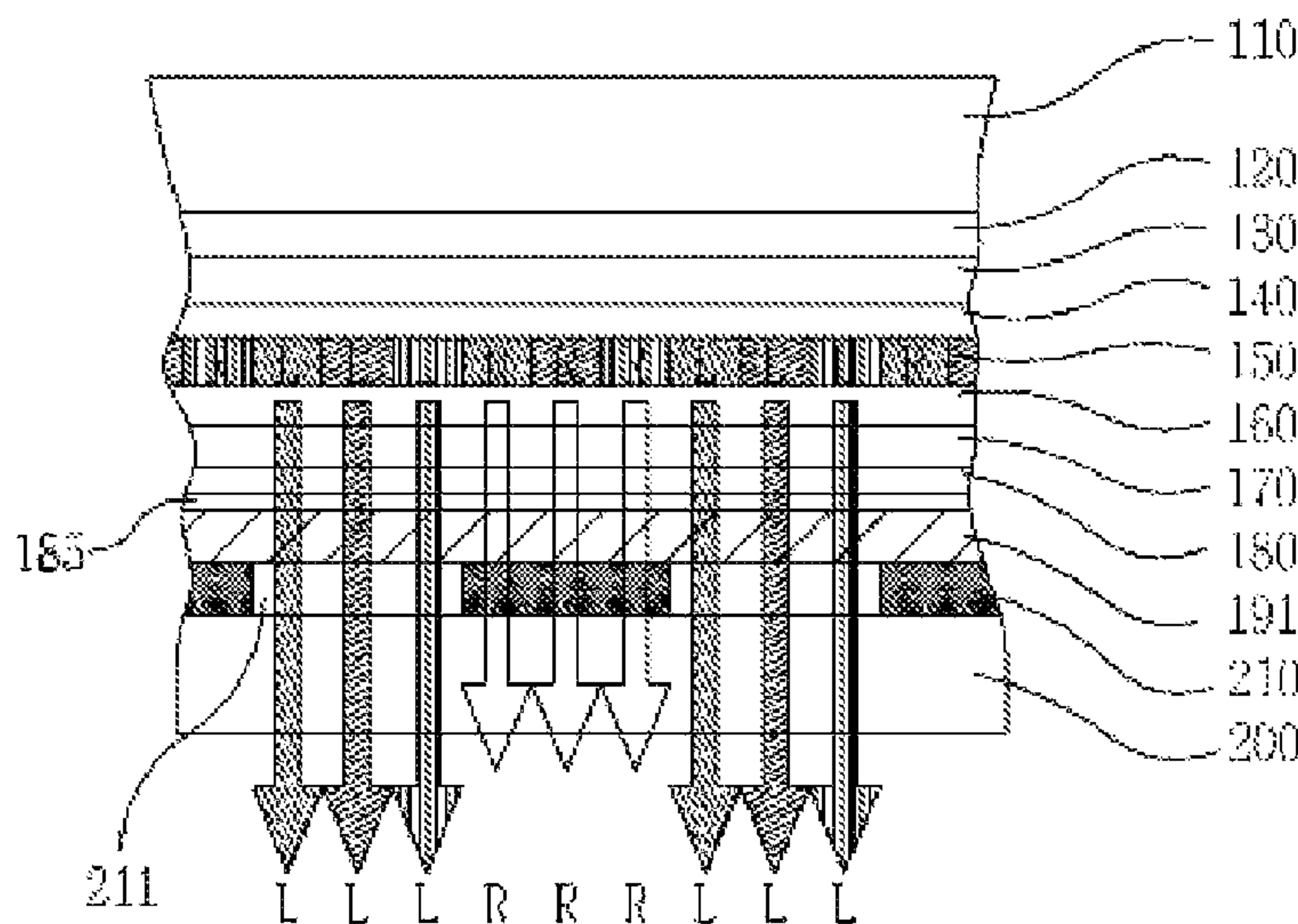

FIG. 1

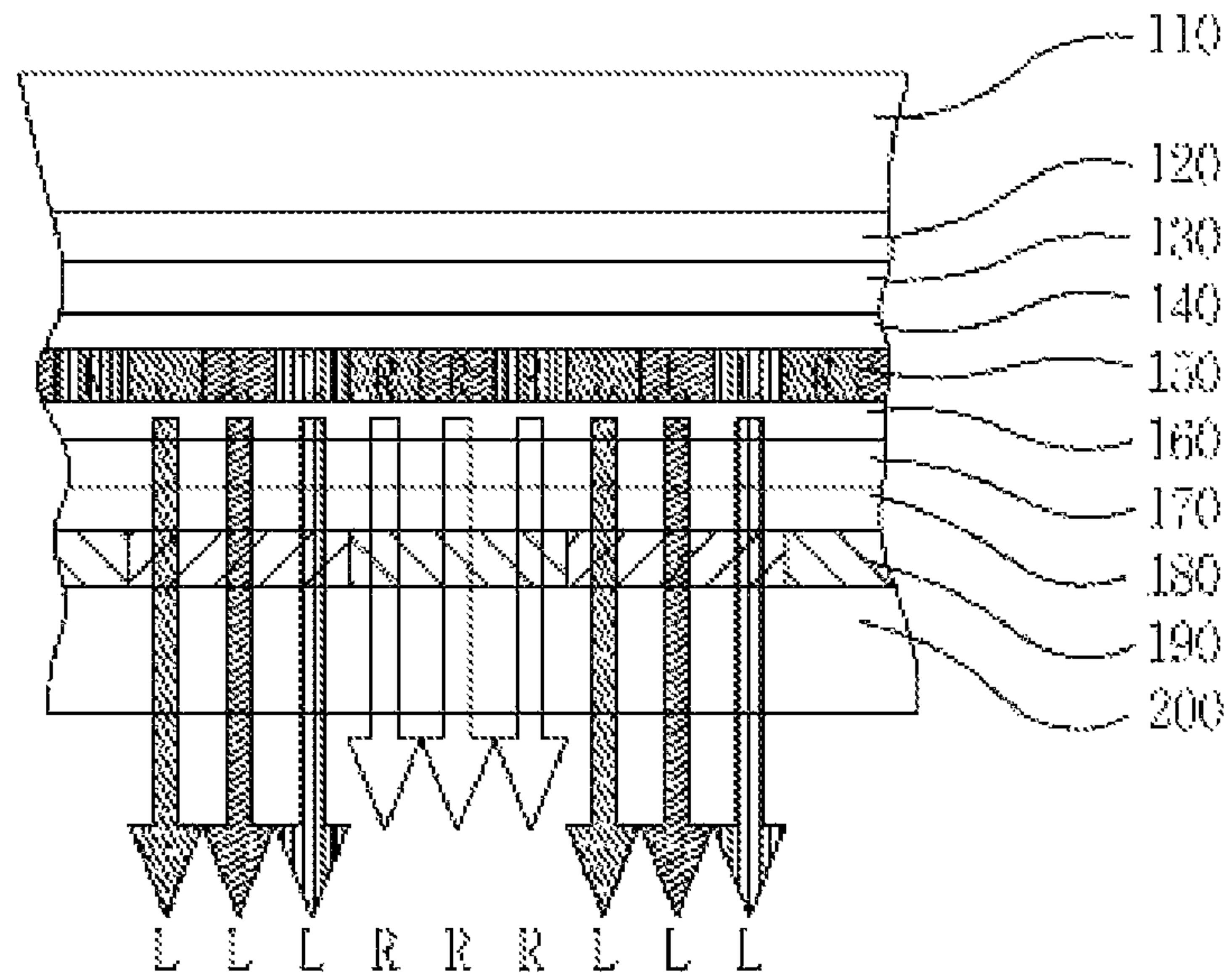

FIG. 2

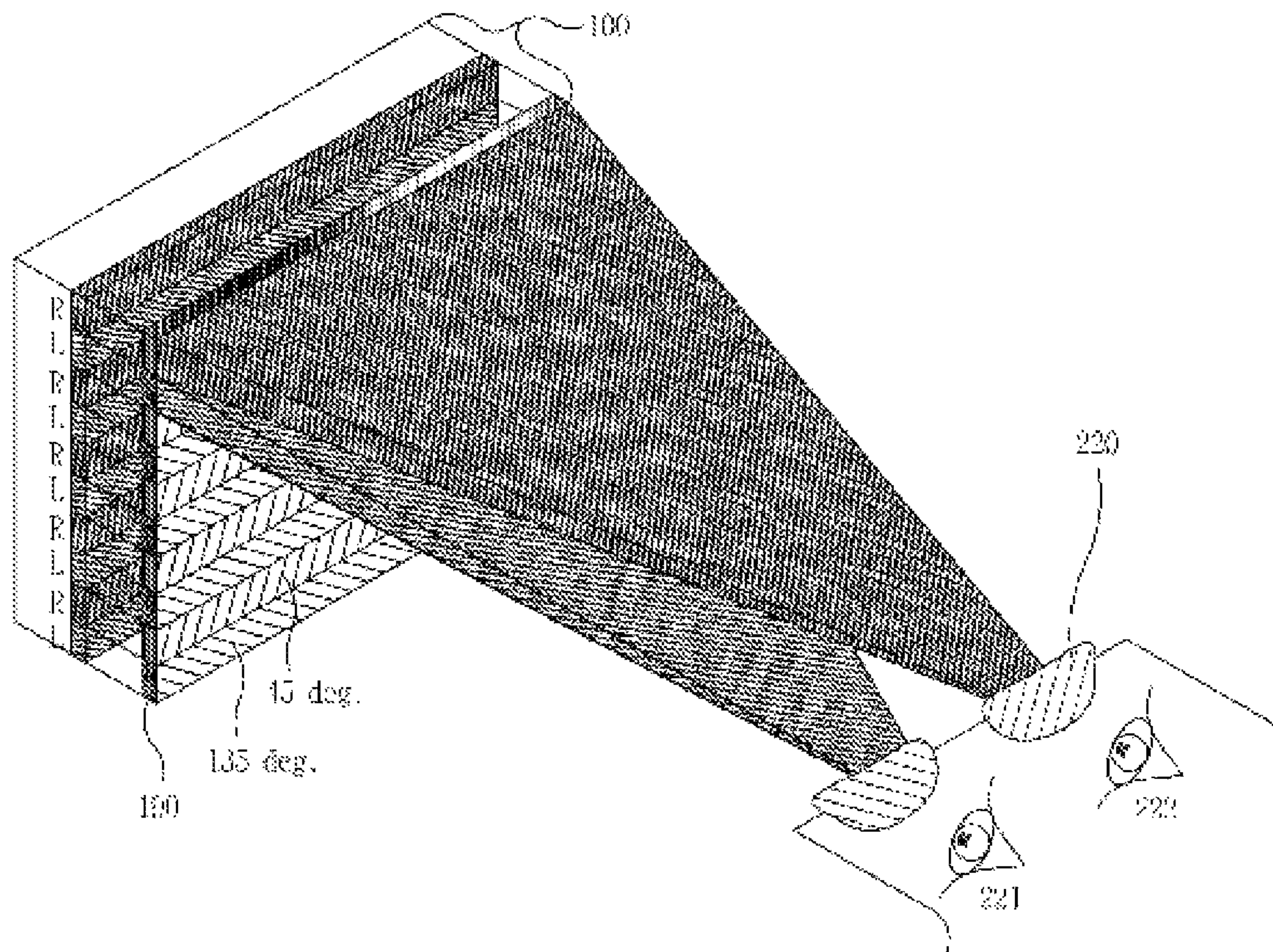

FIG. 3

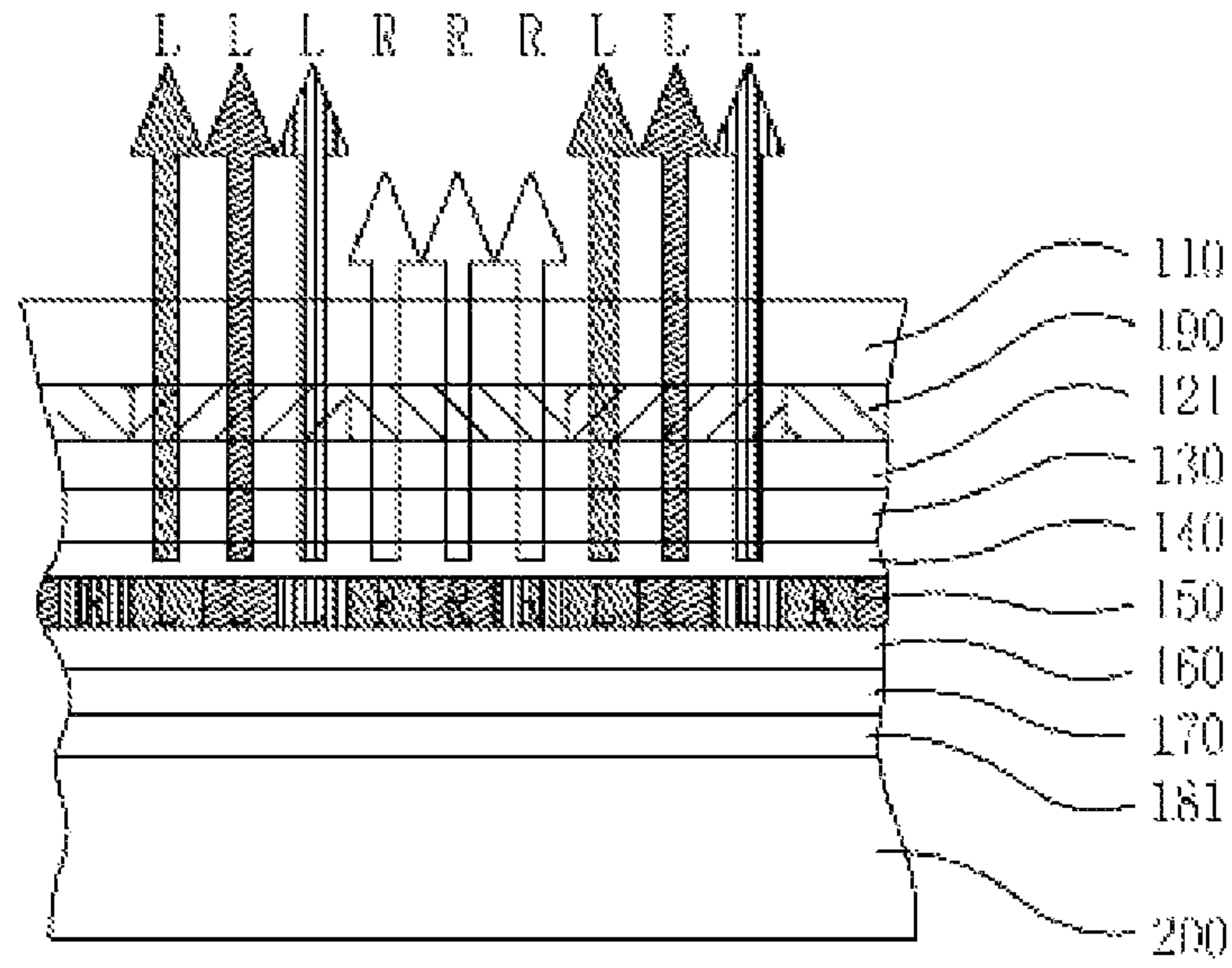

FIG. 4

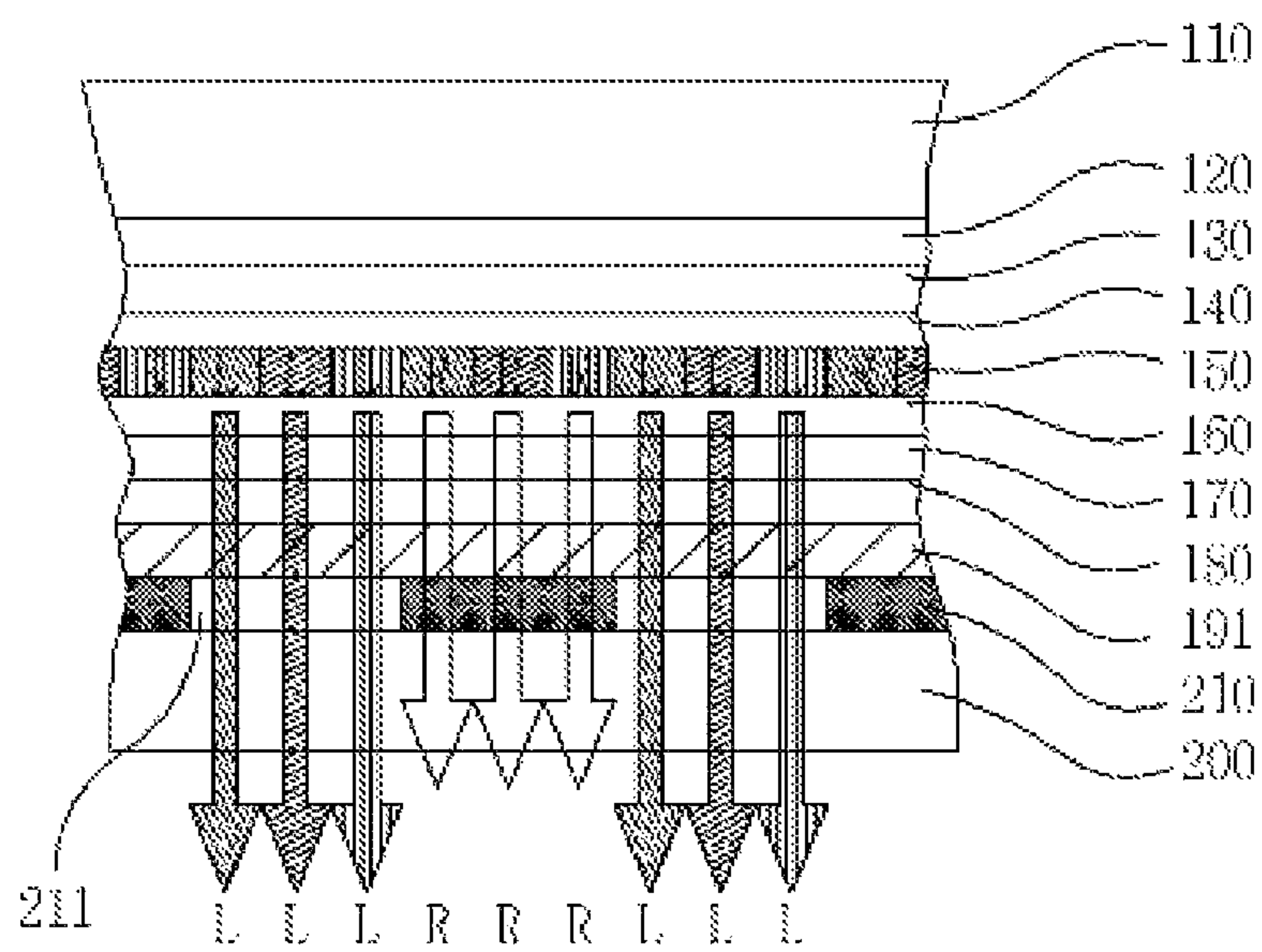

FIG. 5

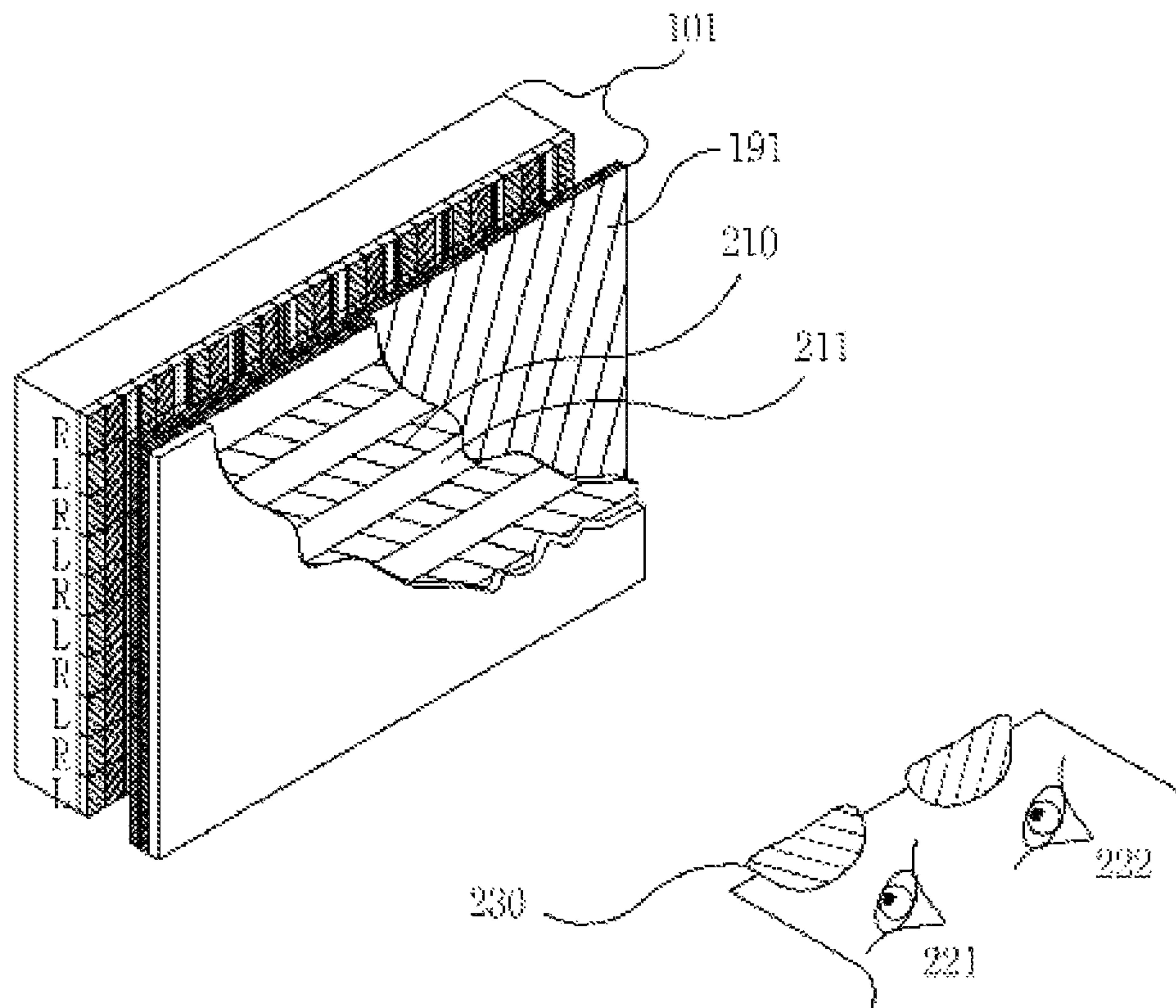

FIG. 6

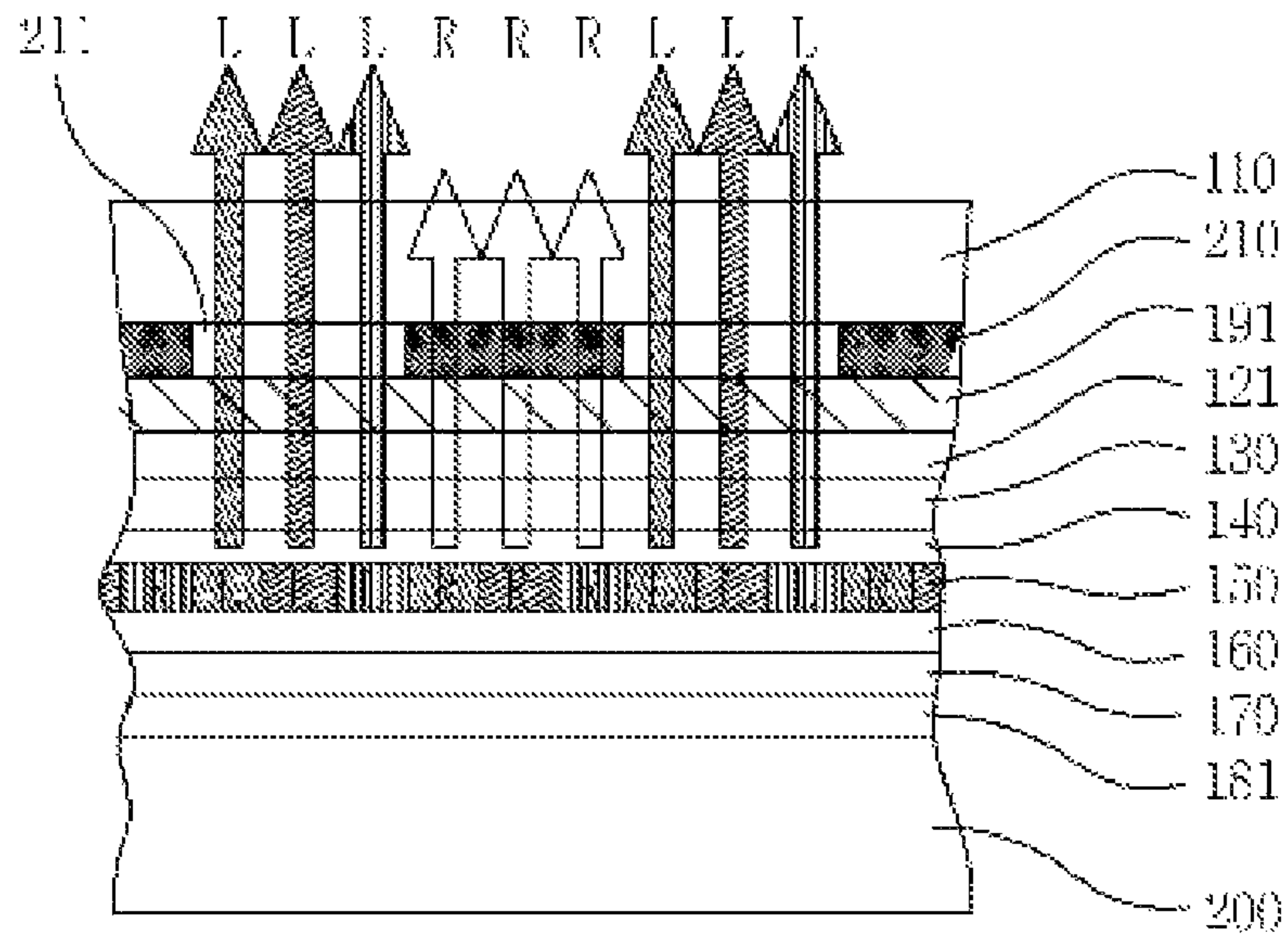

FIG. 9

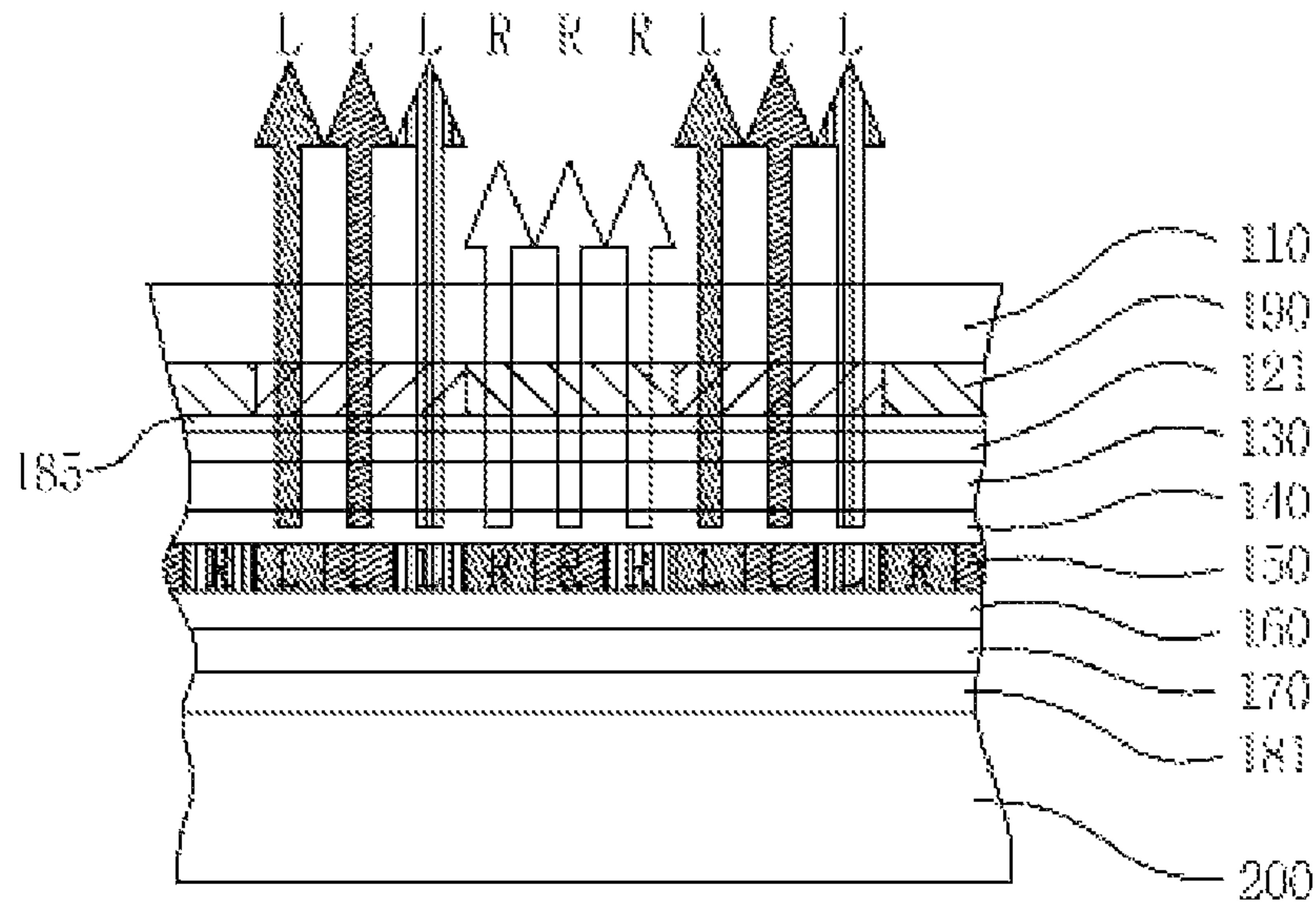

FIG. 10

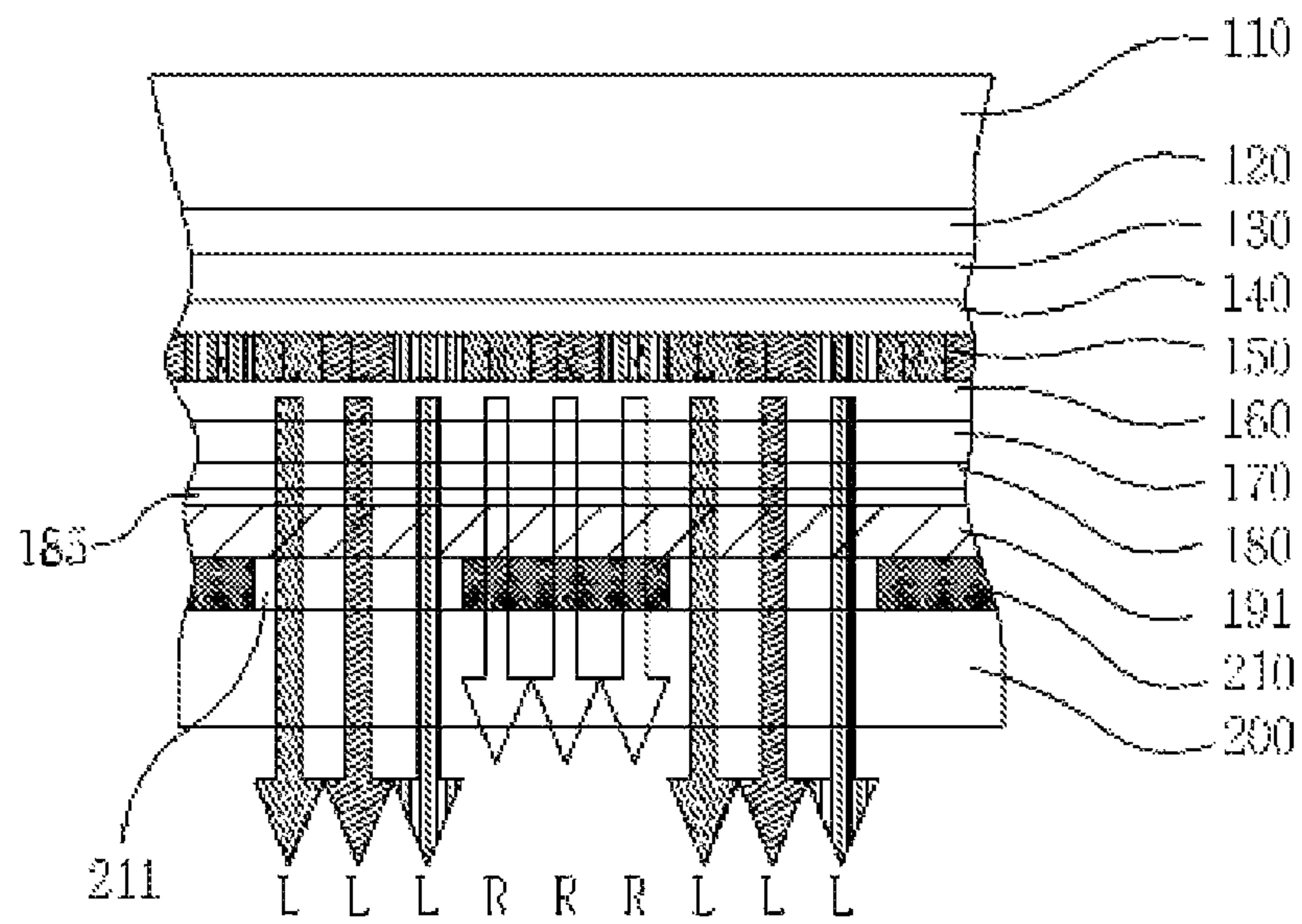

FIG. 11

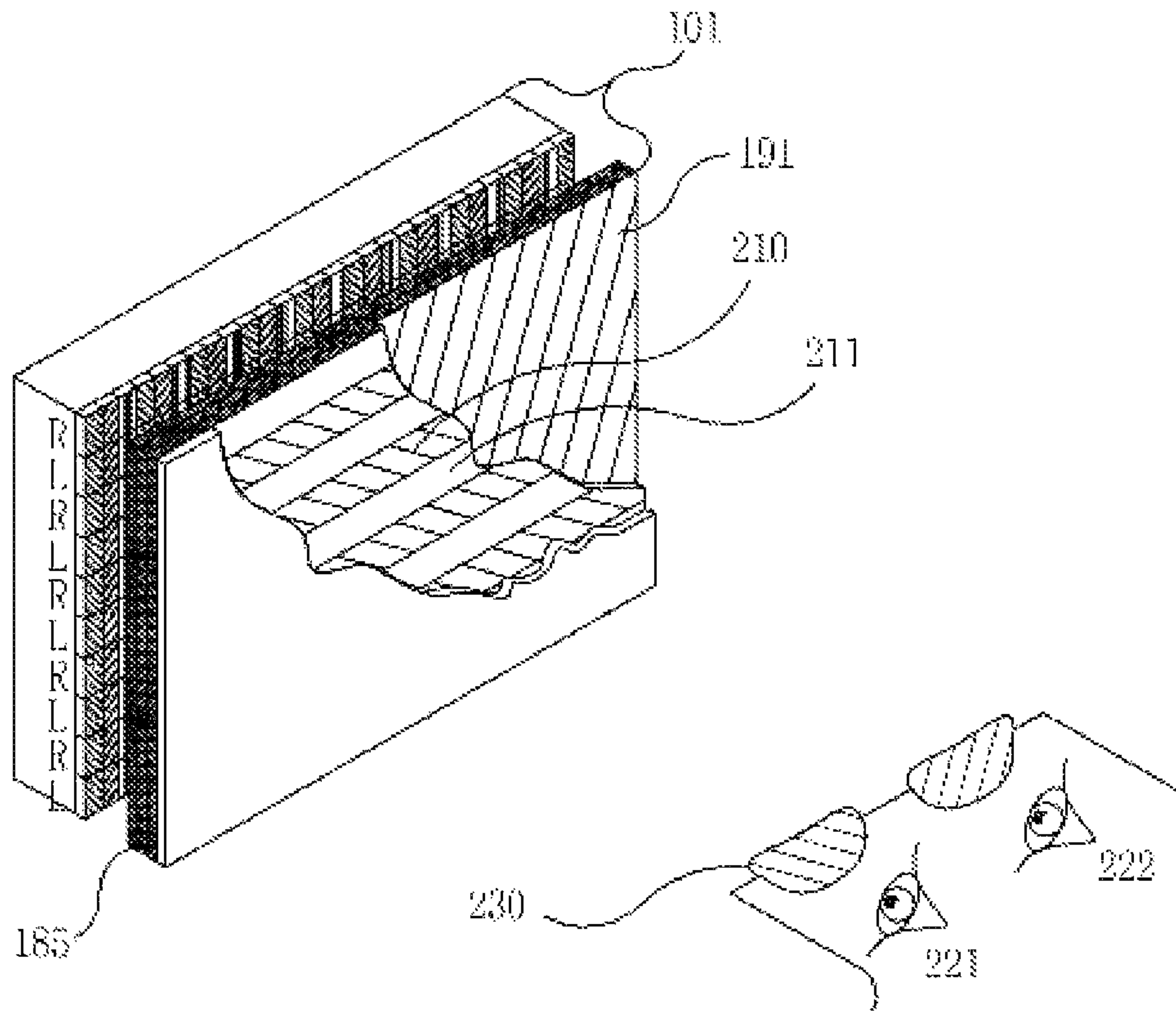
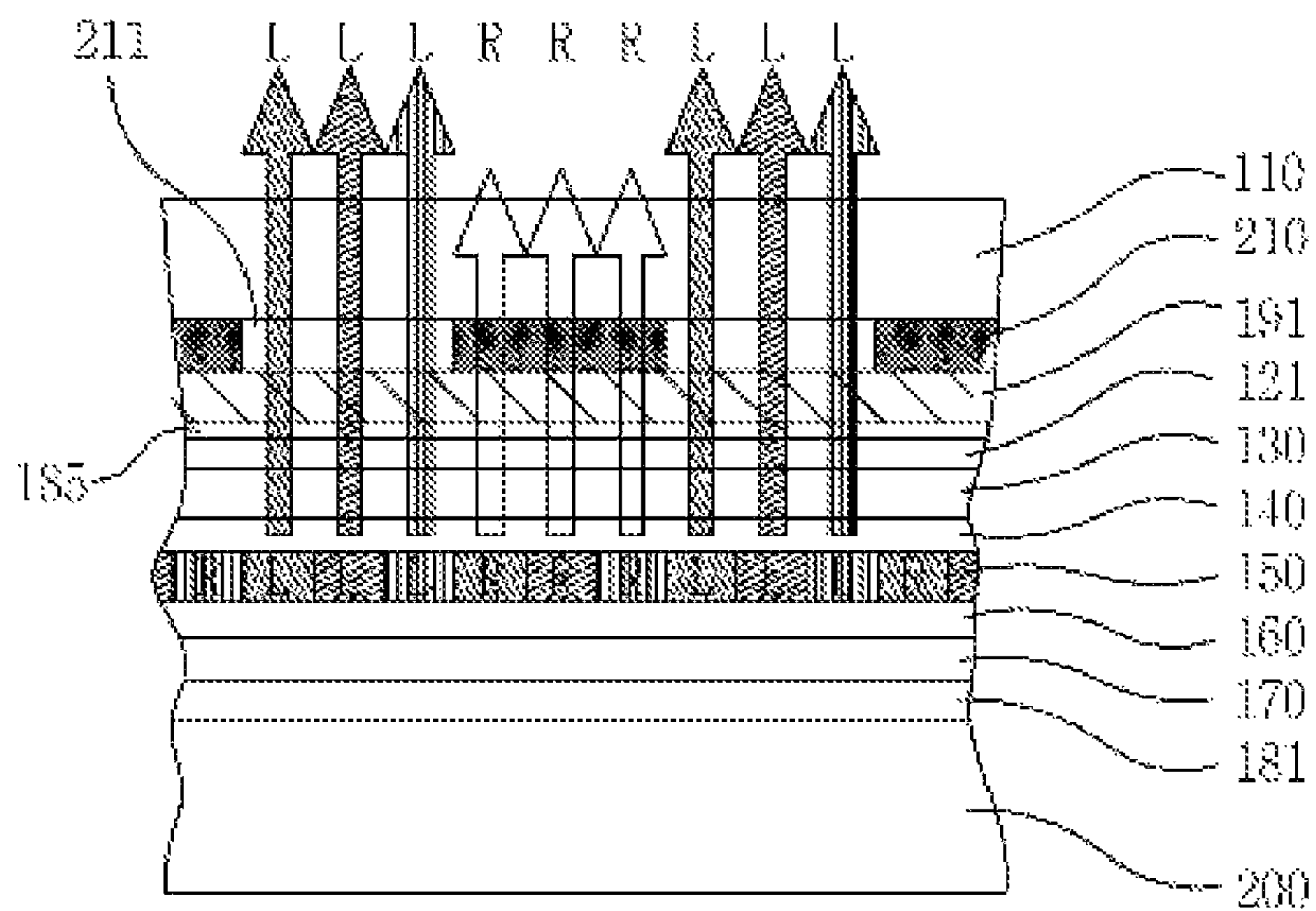

FIG. 12



1

**ORGANIC LIGHT-EMITTING DIODE
THREE-DIMENSIONAL IMAGE DISPLAY
DEVICE**

BACKGROUND OF THE INVENTION

1. Field of the Invention

The present invention relates to an organic light-emitting diode (OLED) three-dimensional (3D) image display device and, more particularly, to an OLED 3D image display device using a wire grid polarizer composed of a metal thin film pattern formed at an angle of 45° and a metal thin film pattern formed at an angle of 135° or a wire grid polarizer formed from a metal thin film pattern formed at an angle of 45° or 0° and a retarder part having a $\frac{1}{4}$ retarder and a $\frac{3}{4}$ retarder which are alternately arranged.

2. Background of the Related Art

When a person sees an object, the person feels three-dimensional effect since his or her eyes respectively see different faces of the object due to a distance of about 65 mm between the left and right eyes. This is referred to as binocular disparity according to the left and right eyes. The images respectively seen by the left and right eyes are composed by the brain and perceived as an image having three-dimensional effect. Three-dimensional images can be displayed using this principle.

In general, three-dimensional images are displayed using the binocular disparity method and autostereoscopic technique. The binocular disparity method uses a disparity image of the left and right eyes and generates great three-dimensional effect.

A conventional three-dimensional image display device was manufactured by attaching an additional panel for displaying three-dimensional images to a two-dimensional image display device, and thus productivity was reduced and production costs increased.

SUMMARY OF THE INVENTION

Accordingly, the present invention has been made in view of the above-mentioned problems occurring in the prior art, and it is a primary object of the present invention to provide an OLED 3D image display device using a wire grid polarizer composed of a metal thin film pattern formed at an angle of 45° and a metal thin film pattern formed at an angle of 135° or a wire grid polarizer formed from a metal thin film pattern formed at an angle of 45° or 0° and a retarder part having a $\frac{1}{4}$ retarder and a $\frac{3}{4}$ retarder which are alternately arranged.

To accomplish the above object of the present invention, according to the present invention, there is provided an organic light-emitting diode (OLED) three-dimensional (3D) image display device which comprises a first substrate, a cathode formed on the first substrate, an electron injection layer formed on the cathode, an electron transfer layer formed on the electron injection layer, an emission layer formed on the electron transfer layer, a hole transfer layer formed on the emission layer, a hole injection layer formed on the hole transfer layer, an anode formed on the hole injection layer, a wire grid polarizer formed on the anode and composed of a metal thin film pattern formed at a first angle and a method thin film pattern formed at a second angle perpendicular to the first angle, which are alternately arranged, and a second substrate arranged on the wire grid polarizer.

OLED 3D image display devices according to embodiments of the present invention use a wire grid polarizer composed of a metal thin film pattern formed at an angle of 45° and a metal thin film pattern formed at an angle of 135° or a

2

wire grid polarizer formed from a metal thin film pattern formed at an angle of 45° or 0° and a retarder part having a $\frac{1}{4}$ retarder and a $\frac{3}{4}$ retarder which are alternately arranged, and thus the OLED 3D image display devices can be easily manufactured at low costs.

BRIEF DESCRIPTION OF THE DRAWINGS

The above and other objects, features and advantages of the present invention will be apparent from the following detailed description of the preferred embodiments of the invention in conjunction with the accompanying drawings, in which:

FIG. 1 is a cross-sectional view of an OLED 3D image display device according to a first embodiment of the present invention;

FIG. 2 is a perspective view of the OLED 3D image display device according to the first embodiment of the present invention;

FIG. 3 is a cross-sectional view of an OLED 3D image display device according to a second embodiment of the present invention;

FIG. 4 is a cross-sectional view of an OLED 3D image display device according to a third embodiment of the present invention;

FIG. 5 is a perspective view of the OLED 3D image display device according to the third embodiment of the present invention;

FIG. 6 is a cross-sectional view of an OLED 3D image display device according to a fourth embodiment of the present invention;

FIG. 7 is a cross-sectional view of an OLED 3D image display device according to a fifth embodiment of the present invention;

FIG. 8 is a perspective view of the OLED 3D image display device according to the fifth embodiment of the present invention;

FIG. 9 is a cross-sectional view of an OLED 3D image display device according to a ninth embodiment of the present invention;

FIG. 10 is a cross-sectional view of an OLED 3D image display device according to a seventh embodiment of the present invention;

FIG. 11 is a perspective view of the OLED 3D image display device according to the seventh embodiment of the present invention; and

FIG. 12 is a cross-sectional view of an OLED 3D image display device according to an eighth embodiment of the present invention.

DETAILED DESCRIPTION OF THE PREFERRED
EMBODIMENT

The present invention will now be described more fully with reference to the accompanying drawings, in which exemplary embodiments of the invention are shown. The invention may, however, be embodied in many different forms and should not be construed as being limited to the embodiments set forth herein; rather, these embodiments are provided so that this disclosure will be thorough and complete, and will fully convey the concept of the invention to those skilled in the art. Like reference numerals in the drawings denote like elements.

FIG. 1 is a cross-sectional view of an OLED 3D image display device according to a first embodiment of the present invention.

Referring to FIG. 1, the OLED 3D image display device according to the first embodiment of the present invention has

a bottom emission type OLED structure and includes a first substrate **110**, a cathode **120**, an electron injection layer **130**, an electron transfer layer **140**, an emission layer **150**, a hole transfer layer **160**, a hole injection layer **170**, an anode **180**, a wire grid polarizer **190**, and a second substrate **200**.

The first and second substrates **110** and **200** may use an organic substrate or a transparent plastic substrate and the cathode **120** may be formed of an alloy such as aluminum-lithium or magnesium-silver on the first substrate **110**. The electron injection layer **130** may be formed of trisaluminum-metalcarboxylate compound on the cathode **120** and the electron transfer layer **140** may be formed of trisaluminum on the electron injection layer **130**.

The emission layer **150** may be formed of an organic material such as dephenylethenyl on the electron transfer layer **140** and emits R, G and B lights. The hole transfer layer **160** may be formed of bis-benzidine (NPB) on the emission layer **150** and the hole injection layer **170** may be formed of copper phthalocyanine (CuPC) on the hole transfer layer **160**.

In addition, the anode **160** may be formed of a transparent electrode material such as indium tin oxide (ITO) on the hole injection layer **170**. The wire grid polarizer **190** is composed of a metal thin film pattern formed at an angle of 45° (or) 0° and a metal thin film pattern formed at an angle of 135° (or) 90° , which are alternately arranged on the anode **180**. Specifically, the wire grid polarizer **190** is formed by coating a metal on the anode **180** to a thickness in the range of 100 nm to 500 nm and patterning the metal film to form the metal thin film pattern at 45° and the metal thin film pattern at 135° . The second substrate **200** is arranged on the wire grid polarizer **190**.

Referring to FIG. 2, light emitted from portions R of the emission layer **150** passes through areas of the wire grid polarizer **190**, which correspond to the metal thin film pattern formed at 45° , and linear polarizing glasses **220** to reach the right eye **222** of an observer and light emitted from portions L of the emission layer **150** passes through areas of the wire grid polarizer **190**, which correspond to the metal thin film pattern formed at 135° , and the linear polarizing glasses **220** to reach the left eye **221** of the observer. The images respectively arrived at the left and right eyes of the observer are composed by the brain of the observer, and thus the observer can feel 3D effect.

FIG. 3 is a cross-sectional view of an OLED 3D image display device according to a second embodiment of the present invention

Referring to FIG. 3, the OLED 3D image display device according to the second embodiment of the present invention has a top emission type OLED structure and includes the first substrate **110**, the wire grid polarizer **190**, a transmissive cathode **121**, the electron injection layer **130**, the electron transfer layer **140**, the emission layer **150**, the hole transfer layer **160**, the hole injection layer **170**, a reflective anode **181**, and the second substrate **200**. The OLED 3D image display device according to the second embodiment of the present invention is distinguished from the OLED 3D image display device according to the first embodiment of the present invention in that the wire grid polarizer **190** is arranged on the first substrate **110** and the OLED 3D image display device includes the transmissive cathode **121** and the reflective anode **181**.

FIG. 4 is a cross-sectional view of an OLED 3D image display device according to a third embodiment of the present invention.

Referring to FIG. 4, the OLED 3D image display device according to the third embodiment of the present invention has a bottom emission OLED structure and includes the first

substrate **110**, the cathode **120**, the electron injection layer **130**, the electron transfer layer **140**, the emission layer **150**, the hole transfer layer **160**, the hole injection layer **170**, the anode **180**, a wire grid polarizer **191**, a retarder part having a $\frac{1}{4}$ retarder **210** and a $\frac{3}{4}$ retarder **211**, which are alternately arranged, and the second substrate **200**.

The first and second substrates **110** and **200** may use an organic substrate or a transparent plastic substrate and the cathode **120** may be formed of an alloy such as aluminum-lithium or magnesium-silver on the first substrate **110**. The electron injection layer **130** may be formed of trisaluminum-metalcarboxylate compound on the cathode **120** and the electron transfer layer **140** may be formed of trisaluminum on the electron injection layer **130**.

The emission layer **150** may be formed of an organic material such as dephenylethenyl on the electron transfer layer **140** and emits R, G and B lights. The hole transfer layer **160** may be formed of bis-benzidine (NPB) on the emission layer **150** and the hole injection layer **170** may be formed of copper phthalocyanine (CuPC) on the hole transfer layer **160**.

In addition, the anode **160** may be formed of a transparent electrode material such as ITO on the hole injection layer **170**. The wire grid polarizer **191** is formed from a metal thin film pattern formed at an angle of 45° or 0° and the retarder part having the $\frac{1}{4}$ retarder **210** and the $\frac{3}{4}$ retarder **211**, which are alternately arranged, is formed on the wire grid polarizer **191**. The second substrate **200** is arranged on the retarder part. Specifically, the wire grid polarizer **191** is formed in such a manner that a metal is coated on the anode **180** to a thickness in the range of 100 nm to 1500 nm and patterned to form the metal thin film pattern at 45° or 0° .

Referring to FIG. 5, light emitted from the portions R of the emission layer **150** passes through the wire grid polarizer **190**, the $\frac{1}{4}$ retarder **210** and circular polarizing glasses **230** to reach the right eye **222** of the observer and light emitted from the portions L of the emission layer **150** passes through the wire grid polarizer **191**, the $\frac{3}{4}$ retarder **211** and the circular polarizing glasses **230** to reach the left eye **221** of the observer. The two images respectively arrived at the left and right eyes of the observer are composed by the brain of the observer, and thus the observer can feel 3D effect.

FIG. 6 is a cross-sectional view of an OLED 3D image display device according to a fourth embodiment of the present invention.

Referring to FIG. 6, the OLED 3D image display device according to the fourth embodiment of the present invention has a top emission type OLED structure and includes the first substrate **110**, the retarder part having the $\frac{1}{4}$ retarder **210** and the $\frac{3}{4}$ retarder **211**, which are alternately arranged, the wire grid polarizer **191**, the transmissive cathode **121**, the electron injection layer **130**, the electron transfer layer **140**, the emission layer **150**, the hole transfer layer **160**, the hole injection layer **170**, a reflective anode **181**, and the second substrate **200**. The OLED 3D image display device according to the fourth embodiment of the present invention is distinguished from the OLED 3D image display device according to the third embodiment of the present invention in that the retarder part is formed on the first substrate **110**, the wire grid polarizer **191** is located on the retarder part, and the OLED 3D image display device includes the transmissive cathode **121** and the reflective anode **181**.

FIG. 7 is a cross-sectional view of an OLED 3D image display device according to a fifth embodiment of the present invention

Referring to FIG. 7, the OLED 3D image display device according to the fifth embodiment of the present invention has a bottom emission type OLED structure and includes the first

5

substrate **110**, the cathode **120**, the electron injection layer **130**, the electron transfer layer **140**, the emission layer **150**, the hole transfer layer **160**, the hole injection layer **170**, the anode **180**, a $\frac{1}{4}$ retarder **185**, the wire grid polarizer **190**, and the second substrate **200**.

The first and second substrates **110** and **200** may use an organic substrate or a transparent plastic substrate and the cathode **120** may be formed of an alloy such as aluminum-lithium or magnesium-silver on the first substrate **110**. The electron injection layer **130** may be formed of trisaluminum-metalcarboxylate compound on the cathode **120** and the electron transfer layer **140** may be formed of trisaluminum on the electron injection layer **130**.

The emission layer **150** may be formed of an organic material such as dephenylethenyl on the electron transfer layer **140** and emits R, G and B lights. The hole transfer layer **160** may be formed of bis-benzidine (NPB) on the emission layer **150** and the hole injection layer **170** may be formed of copper phthalocyanine (CuPC) on the hole transfer layer **160**.

In addition, the anode **160** may be formed of a transparent electrode material such as ITO on the hole injection layer **170**. The $\frac{1}{4}$ retarder **185** may be formed on the anode **180**. The wire grid polarizer **190** is composed of a metal thin film pattern formed at an angle of 45° (or 0°) and a method thin film pattern formed at an angle of 135° (or 90°), which are alternately arranged on the $\frac{1}{4}$ retarder **185**. Specifically, the wire grid polarizer **190** is formed by coating a metal on the $\frac{1}{4}$ retarder **185** to a thickness in the range of 100 nm to 500 nm and patterning the metal film to form the metal thin film pattern arranged at 45° and the method thin film pattern arranged at 135° . The second substrate **200** is arranged on the wire grid polarizer **190**.

Referring to FIG. 8, light emitted from the portions R of the emission layer **150** passes through the areas of the wire grid polarizer **190**, which correspond to the metal thin film pattern arranged at 45° , and the linear polarizing glasses **220** to reach the right eye **222** of an observer and light emitted from the portions L of the emission layer **150** passes through the areas of the wire grid polarizer **190**, which correspond to the metal thin film pattern arranged at 135° , and the linear polarizing glasses **220** to reach the left eye **221** of the observer. The images respectively arrived at the left and right eyes of the observer are composed by the brain of the observer, and thus the observer can feel 3D effect.

FIG. 9 is a cross-sectional view of an OLED 3D image display device according to a sixth embodiment of the present invention.

Referring to FIG. 9, the OLED 3D image display device according to the sixth embodiment of the present invention has a top emission type OLED structure and includes the first substrate **110**, the wire grid polarizer **190**, the transfective cathode **121**, the electron injection layer **130**, the electron transfer layer **140**, the emission layer **150**, the hole transfer layer **160**, the hole injection layer **170**, a reflective anode **181**, the $\frac{1}{4}$ retarder **185**, and the second substrate **200**. The OLED 3D image display device according to the sixth embodiment of the present invention is distinguished from the OLED 3D image display device according to the fifth embodiment of the present invention in that the wire grid polarizer **190** is arranged on the first substrate **110** and the OLED 3D image display device includes the transfective cathode **121** and the reflective anode **181**.

FIG. 10 is a cross-sectional view of an OLED 3D image display device according to a seventh embodiment of the present invention.

Referring to FIG. 10, the OLED 3D image display device according to the seventh embodiment of the present invention

6

has a bottom emission type OLED structure and includes the first substrate **110**, the cathode **120**, the electron injection layer **130**, the electron transfer layer **140**, the emission layer **150**, the hole transfer layer **160**, the hole injection layer **170**, the anode **180**, the upper $\frac{1}{4}$ retarder **185**, the wire grid polarizer **191**, a retarder part having the lower $\frac{1}{4}$ retarder **210** and the $\frac{3}{4}$ retarder **211**, which are alternately arranged, and the second substrate **200**.

The first and second substrates **110** and **200** may use an organic substrate or a transparent plastic substrate and the cathode **120** may be formed of an alloy such as aluminum-lithium or magnesium-silver on the first substrate **110**. The electron injection layer **130** may be formed of trisaluminum-metalcarboxylate compound on the cathode **120** and the electron transfer layer **140** may be formed of trisaluminum on the electron injection layer **130**.

The emission layer **150** may be formed of an organic material such as dephenylethenyl on the electron transfer layer **140** and emits R, G and B lights. The hole transfer layer **160** may be formed of bis-benzidine (NPB) on the emission layer **150** and the hole injection layer **170** may be formed of copper phthalocyanine (CuPC) on the hole transfer layer **160**.

In addition, the anode **160** may be formed of a transparent electrode material such as ITO on the hole injection layer **170**. The upper $\frac{1}{4}$ retarder **185** may be formed on the anode **180**. The wire grid polarizer **191** is formed from a metal thin film pattern arranged at an angle of 45° or 0° and the upper retarder **185**, and the retarder part having the lower $\frac{1}{4}$ retarder **210** and the $\frac{3}{4}$ retarder **211**, which are alternately arranged, is formed on the wire grid polarizer **191**. The second substrate **200** is located on the retarder part. Specifically, the wire grid polarizer **191** is formed in such a manner that a metal is coated on the anode **180** to a thickness in the range of 100 nm to 1500 nm and patterned to form the metal thin film pattern arranged at 45° or 0° .

Referring to FIG. 1, light emitted from the portions R of the emission layer **150** passes through the upper $\frac{1}{4}$ retarder **185**, the wire grid polarizer **191**, the $\frac{1}{4}$ retarder **210** and circular polarizing glasses **230** to reach the right eye **222** of the observer and light emitted from the portions L of the emission layer **150** passes through the upper $\frac{1}{4}$ retarder **185**, the wire grid polarizer **191**, the $\frac{3}{4}$ retarder **211** and the circular polarizing glasses **230** to reach the left eye **221** of the observer. The images respectively arrived at the left and right eyes of the observer are composed by the brain of the observer, and thus the observer can feel 3D effect.

FIG. 12 is a cross-sectional view of an OLED 3D image display device according to an eighth embodiment of the present invention.

Referring to FIG. 12, the OLED 3D image display device according to the eighth embodiment of the present invention has a top emission type OLED structure and includes the first substrate **110**, the retarder part having the lower $\frac{1}{4}$ retarder **210** and the $\frac{3}{4}$ retarder **211**, which are alternately arranged, the wire grid polarizer **191**, the transfective cathode **121**, the electron injection layer **130**, the electron transfer layer **140**, the emission layer **150**, the hole transfer layer **160**, the hole injection layer **170**, the reflective anode **181**, and the second substrate **200**.

The OLED 3D image display device according to the eighth embodiment of the present invention is distinguished from the OLED 3D image display device according to the seventh embodiment of the present invention in that the retarder part is formed on the first substrate **110**, the wire grid polarizer **191** is arranged on the retarder part, and the OLED 3D image display device includes the transfective cathode **121** and the reflective anode **181**.

While the present invention has been described with reference to the particular illustrative embodiments, it is not to be restricted by the embodiments but only by the appended claims. It is to be appreciated that those skilled in the art can change or modify the embodiments without departing from the scope and spirit of the present invention. 5

What is claimed is:

1. An OLED 3D image display device comprising:
 - a first substrate;
 - a cathode formed on the first substrate; 10
 - an electron injection layer formed on the cathode;
 - an electron transfer layer formed on the electron injection layer;
 - an emission layer formed on the electron transfer layer;
 - a hole transfer layer formed on the emission layer; 15
 - a hole injection layer formed on the hole transfer layer;
 - an anode formed on the hole injection layer;
 - an upper $\frac{1}{4}$ retarder formed on the anode;
 - a wire grid polarizer arranged on the upper $\frac{1}{4}$ retarder and formed from a metal thin film pattern formed in one 20 direction;
 - a retarder part having a lower $\frac{1}{4}$ retarder and a $\frac{3}{4}$ retarder which are alternately formed on the wire grid polarizer; and
 - a second substrate arranged on the retarder part. 25
2. The OLED 3D image display device of claim 1, wherein the wire grid polarizer is formed from a metal thin film pattern formed at an angle of 0° .
3. The OLED 3D image display device of claim 1, wherein the wire grid polarizer is formed from a metal thin film pattern 30 formed at an angle of 45° .

* * * * *