



US008627587B2

(12) **United States Patent**  
**O'Dell**

(10) **Patent No.:** **US 8,627,587 B2**  
(45) **Date of Patent:** **Jan. 14, 2014**

(54) **DOUBLE WIDE POLE BRACKET AND BANNER SYSTEM**

(71) Applicant: **David Trevor O'Dell**, Evansville, IN (US)

(72) Inventor: **David Trevor O'Dell**, Evansville, IN (US)

(\* ) Notice: Subject to any disclaimer, the term of this patent is extended or adjusted under 35 U.S.C. 154(b) by 0 days.

2,899,764	A *	8/1959	Oberlin	40/604
2,954,627	A *	10/1960	Kies	40/604
2,960,784	A *	11/1960	Frey et al.	40/604
3,089,268	A *	5/1963	Frey et al.	40/604
3,217,437	A *	11/1965	Cobb	40/604
3,310,899	A *	3/1967	Hart et al.	40/604
3,593,450	A *	7/1971	Mollet et al.	40/604
3,609,894	A *	10/1971	Miller	40/655
3,675,356	A *	7/1972	Gilmoure	40/604
3,726,035	A *	4/1973	Bower et al.	40/604
3,842,524	A *	10/1974	Drueck, Jr.	40/606.15
4,890,403	A *	1/1990	Dinan	40/604
5,428,913	A *	7/1995	Hillstrom	40/604
7,810,265	B2 *	10/2010	Beatty	40/607.14

\* cited by examiner

(21) Appl. No.: **13/851,924**

(22) Filed: **Mar. 27, 2013**

(65) **Prior Publication Data**

US 2013/0255121 A1 Oct. 3, 2013

**Related U.S. Application Data**

(60) Provisional application No. 61/616,841, filed on Mar. 28, 2012.

(51) **Int. Cl.**  
**G09F 15/02** (2006.01)

(52) **U.S. Cl.**  
USPC ..... **40/607.12**; 40/604

(58) **Field of Classification Search**  
USPC ..... 40/604, 607.01, 607.12  
See application file for complete search history.

(56) **References Cited**

**U.S. PATENT DOCUMENTS**

2,882,630	A *	4/1959	Frey	40/604
2,893,147	A *	7/1959	Mollet, III	40/604

*Primary Examiner* — Gary Hoge

(74) *Attorney, Agent, or Firm* — Canyon Law Group

(57) **ABSTRACT**

A double wide pole bracket and banner system is used to apply banners to poles. The double wide pole bracket system uses slotted, typically steel channel brackets that are affixed to the pole using long, slotted hose clamps with Neoprene pads to protect the pole and prevent slipping. The banner itself can be designed to attach to the brackets with zip ties with a reinforced cutout in the center of the top and bottom hem that permits mounting without infringing on the view of the banner's content. The double wide pole bracket and banner system permits a significantly wider, stronger and more taut pole bracket and banner solution as compared to conventional solutions. The banners can be, for example, as wide as five feet of continuous banner, making the message visible and understandable.

**10 Claims, 5 Drawing Sheets**

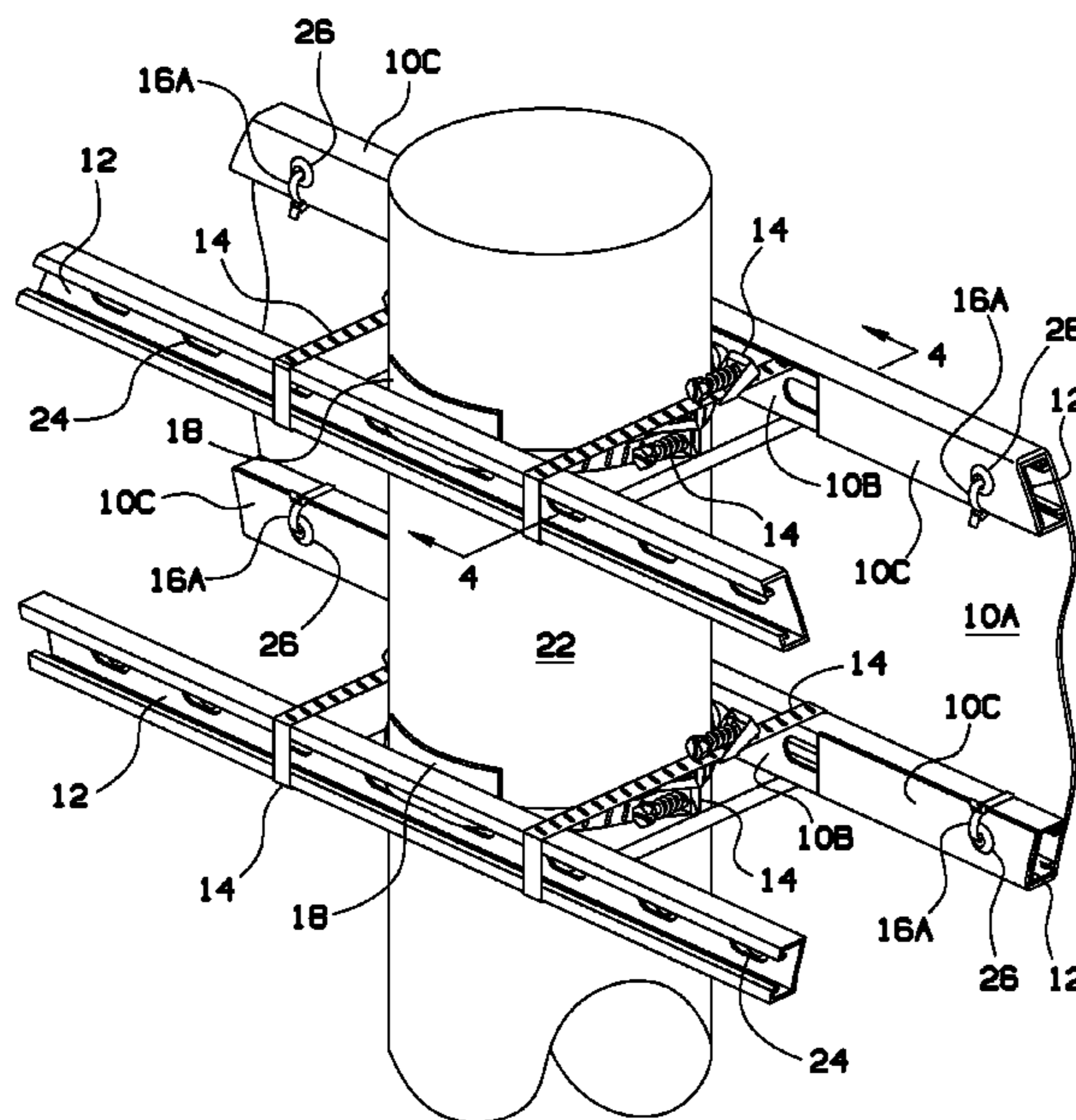

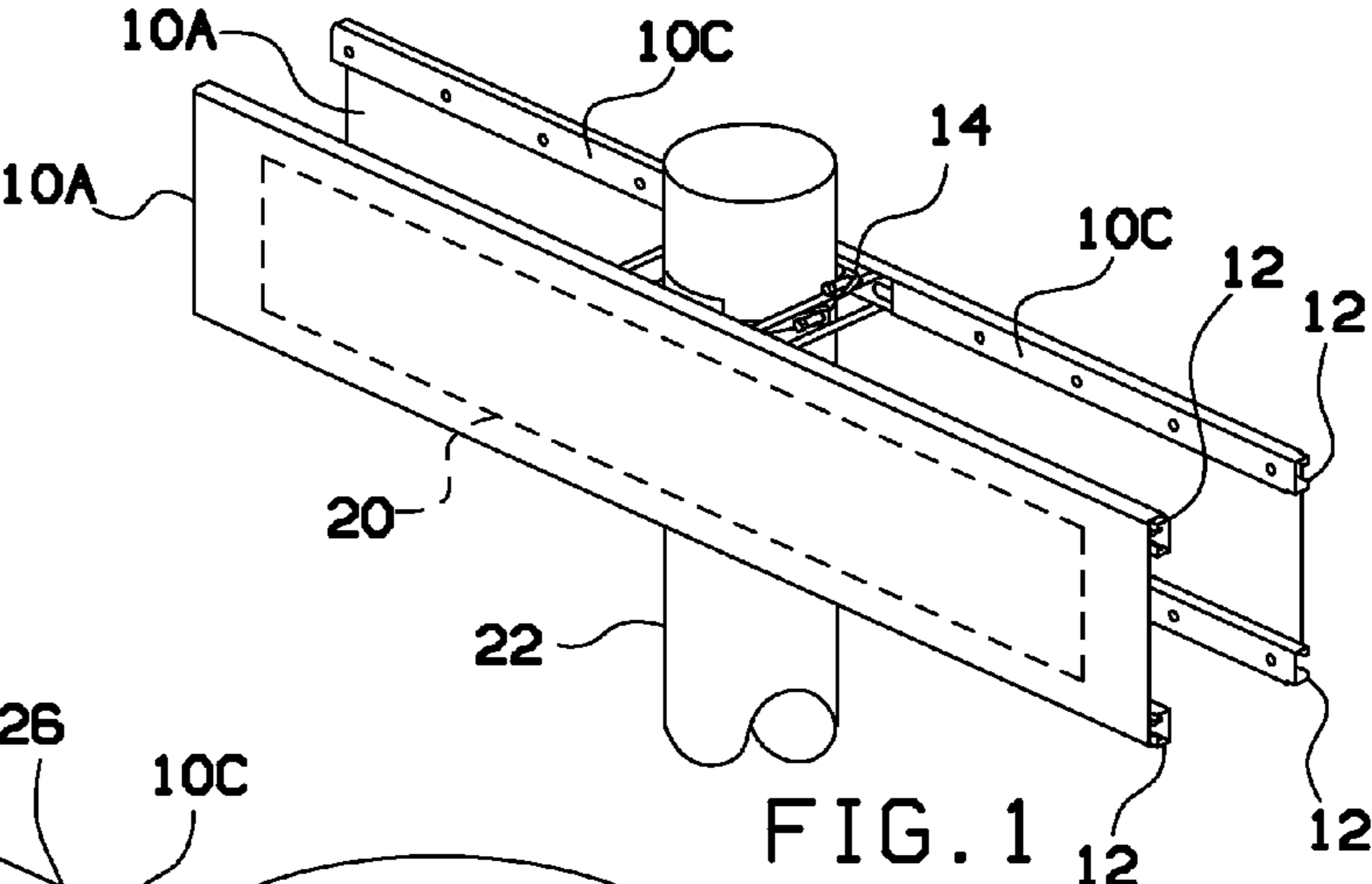

FIG. 1

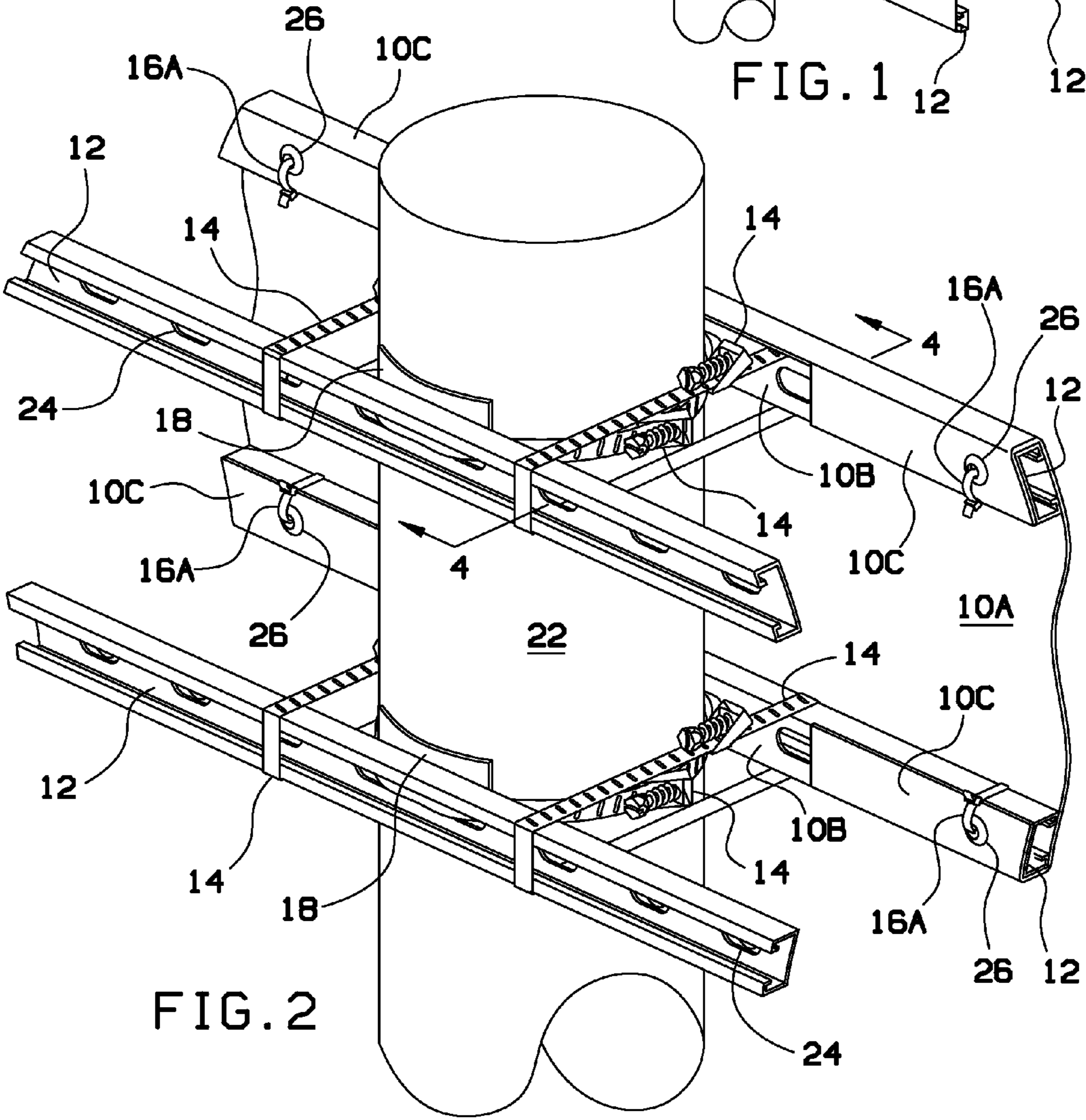

FIG. 2

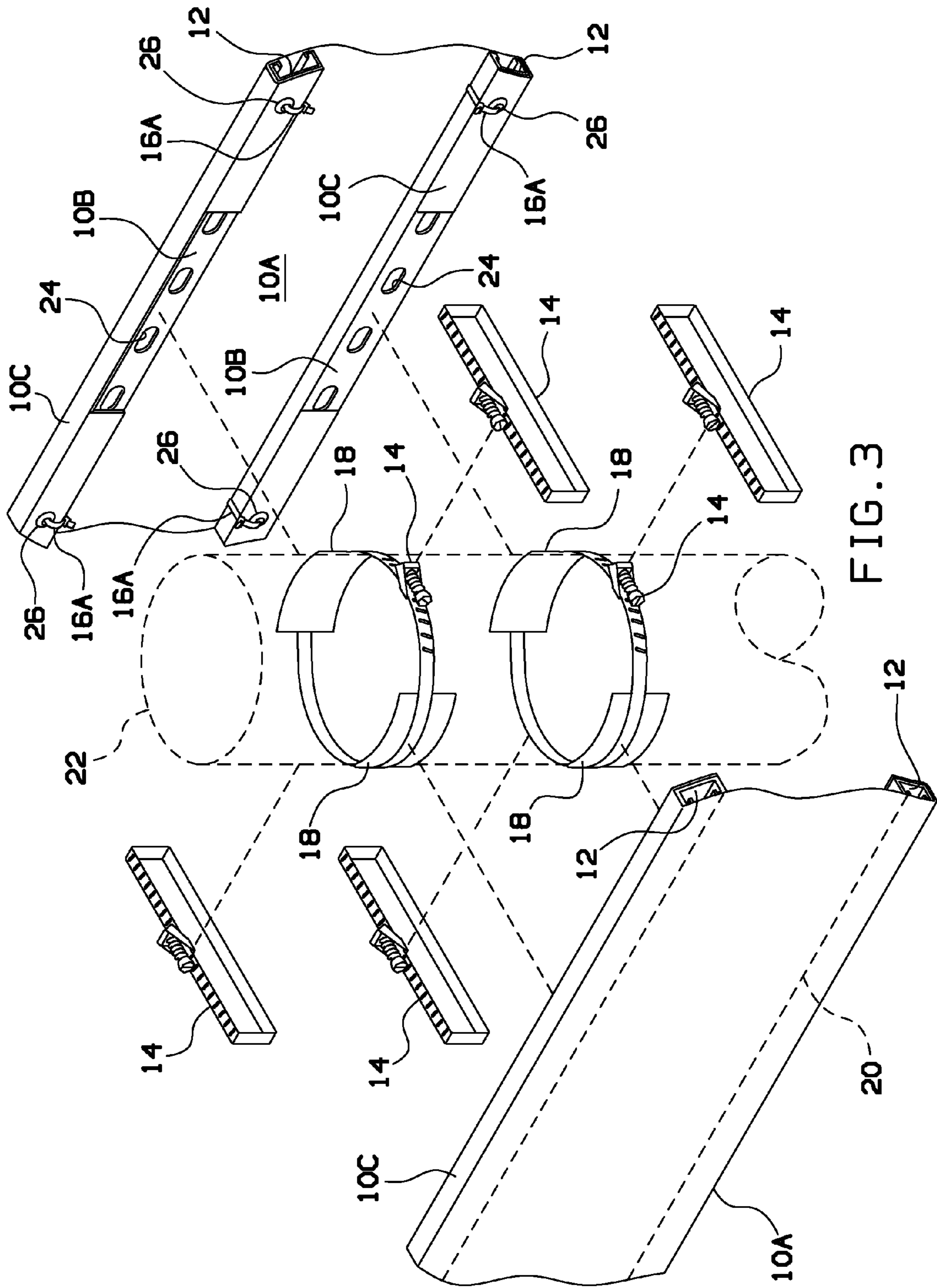

FIG. 3



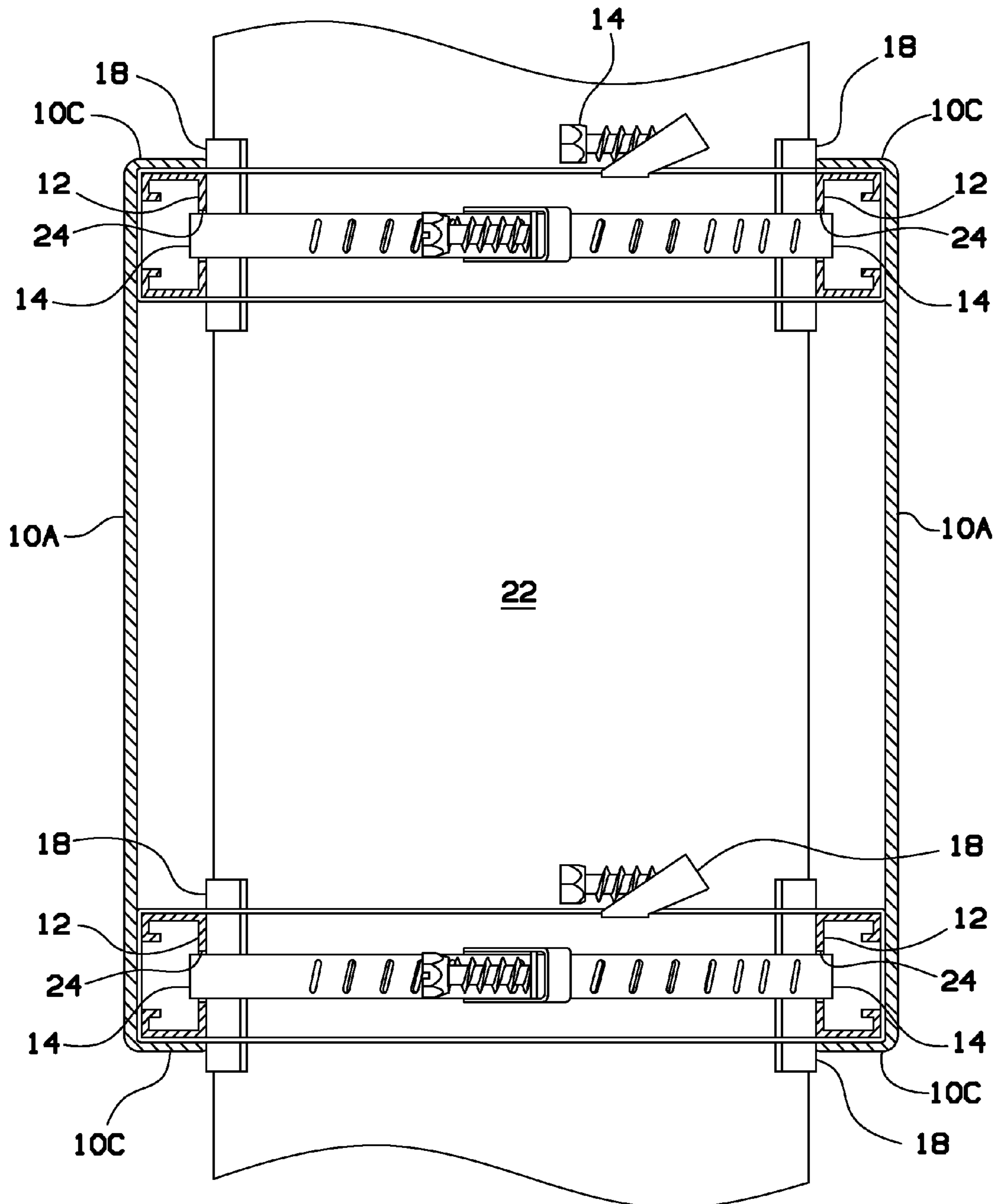

FIG. 4

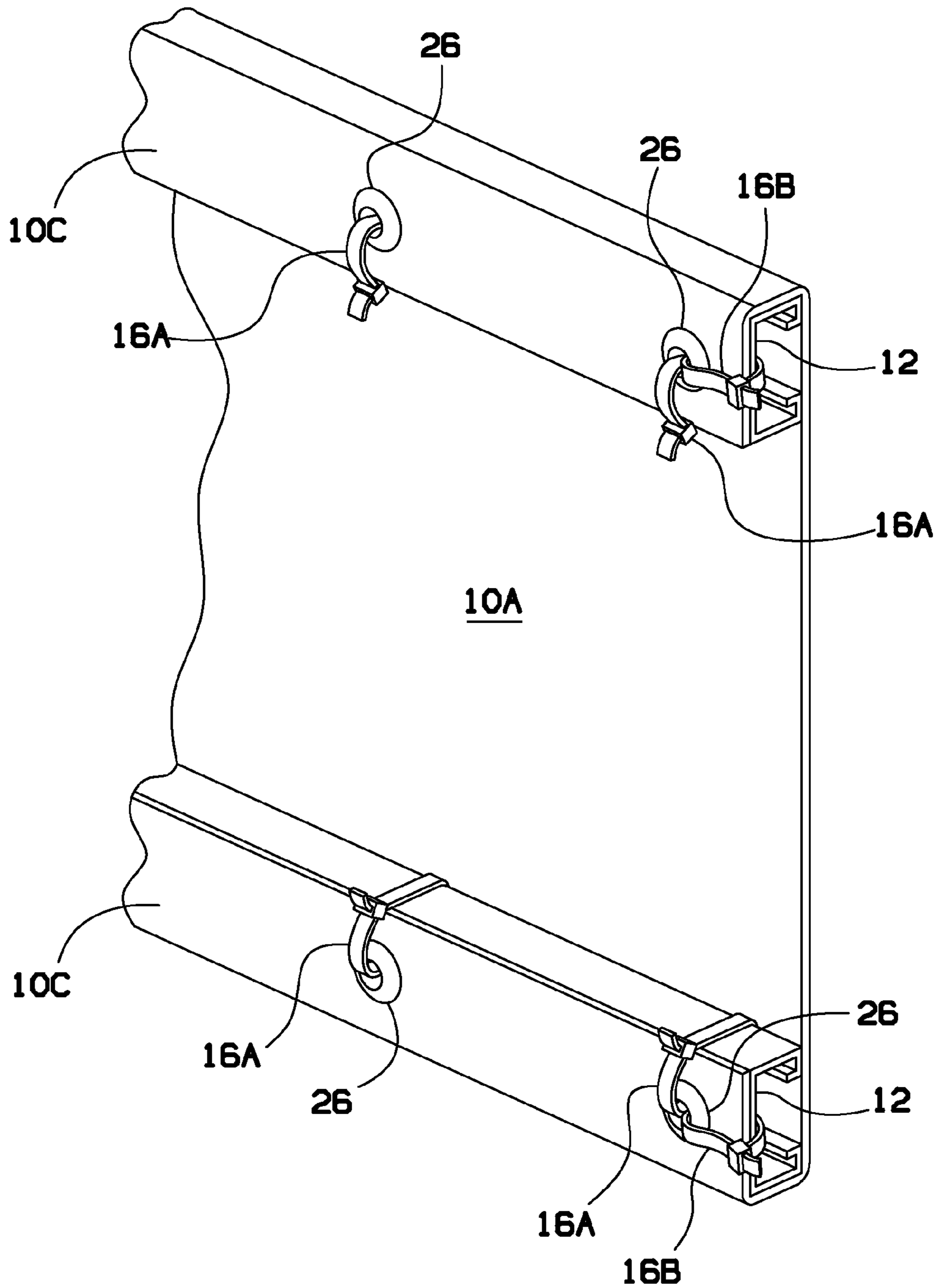

FIG. 5

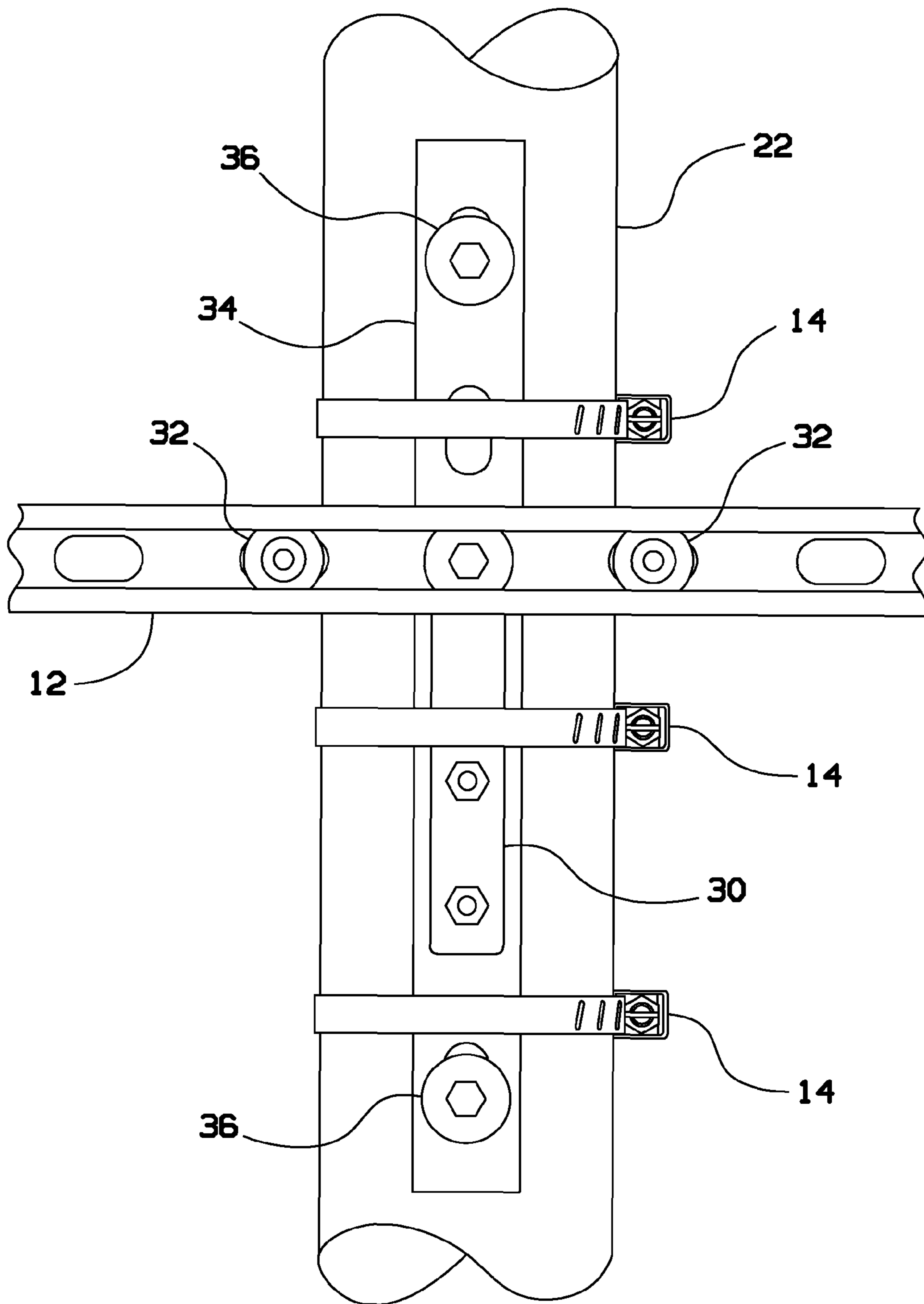

FIG. 6



1

## DOUBLE WIDE POLE BRACKET AND BANNER SYSTEM

### CROSS-REFERENCE TO RELATED APPLICATION

This application claims the benefit of priority of U.S. provisional application No. 61/616,841, filed Mar. 28, 2012, the contents of which are herein incorporated by reference.

### BACKGROUND OF THE INVENTION

The present invention relates to banner brackets and, more particularly, to a double wide pole bracket and banner system for the application of banners to poles.

Almost all available pole banners and bracket systems have several problems. For example, the banner needs to be designed as tall and narrow banners, and hung on the sides of a pole, rendering the graphic and/or message hard to decipher or understand. The bracket is typically made of fiberglass, inserted into a receptor, and strapped to a pole, which can break or blow off in strong winds. Additionally, the bracket hardware is readily visible, unattractive and can easily damage the supporting pole. Furthermore, because the banners have pole pockets on the top and bottom, they often hang loosely, making the banners additionally prone to ripping and even coming off.

As can be seen, there is a need for an improved system for mounting banners onto a pole that can allow "double wide" banners to be applied in a secure and convenient manner, without visible hardware and without damaging the pole on which the banner is mounted.

### SUMMARY OF THE INVENTION

In one aspect of the present invention, a pole bracket and banner system comprises a first set of two channel brackets disposed at a first height on a pole; a second set of two channel brackets disposed at a second height on the pole; a plurality of channel slots in the first and second sets of two channel brackets; a first adjustable strap disposed about the pole at the first height, the first adjustable strap extending into one of the plurality of channel slots on each of the first set of two channel brackets and exiting from an adjacent one of the plurality of channel slots on each of the first set of two channel brackets, where tightening the adjustable to the pole secures the first set of two channel brackets at the first height; a second adjustable strap disposed about the pole at the second height, the second adjustable strap extending into one of the plurality of channel slots on each of the second set of two channel brackets and exiting from an adjacent one of the plurality of channel slots on each of the second set of two channel brackets, where tightening the adjustable to the pole secures the second set of two channel brackets at the second height; a first set of two adjustable straps extending about and interconnecting the first set of two channel brackets on each side of the pole; and a second set of two adjustable straps extending about and interconnecting the second set of two channel brackets on each side of the pole.

In another aspect of the present invention, a banner display system includes a vinyl or mesh banner created with welded hem at the top and the bottom and an appropriate number of grommets that allow the affixing of the banner to the channels above. Furthermore, there is a reinforced cutout in the middle of the top and bottom of the banner that permits affixing and tightening the banner with black zip ties without distortion.

2

These and other features, aspects and advantages of the present invention will become better understood with reference to the following drawings, description and claims.

### BRIEF DESCRIPTION OF THE DRAWINGS

FIG. 1 is a perspective view of a double wide pole bracket, in use to apply a banner to a round pole, according to an exemplary embodiment of the present invention;

FIG. 2 is a detailed perspective view of the double wide pole bracket of FIG. 1, with the banner removed for clarity;

FIG. 3 is an exploded perspective view of the double wide pole bracket of FIG. 1;

FIG. 4 is a cross-sectional view taken along line 4-4 of FIG. 2;

FIG. 5 is a detailed perspective view of the double wide pole bracket, in use to apply a banner to a pole, illustrating the use of an additional tie wrap at each end of the channel; and

FIG. 6 is a perspective view illustrating a method for preventing slipping of a banner on a round pole according to an exemplary embodiment of the present invention.

### DETAILED DESCRIPTION OF THE INVENTION

The following detailed description is of the best currently contemplated modes of carrying out exemplary embodiments of the invention. The description is not to be taken in a limiting sense, but is made merely for the purpose of illustrating the general principles of the invention, since the scope of the invention is best defined by the appended claims.

Broadly, an embodiment of the present invention provides a double wide pole bracket and banner system for applying banners to poles. The double wide pole bracket system uses slotted, typically steel channel brackets that are affixed to the pole using long, slotted hose clamps with Neoprene pads to protect the pole and prevent slipping. The banner itself can be designed to attach to the brackets with zip ties with a reinforced cutout in the center of the top and bottom hem that permits mounting without infringing on the view of the banner's content. The double wide pole bracket and banner system permits a significantly wider, stronger and more taut pole bracket and banner solution as compared to conventional solutions. The banners can be, for example, as wide as five feet of continuous banner, making the message visible and understandable.

Referring now to FIGS. 1 through 5, a banner 10 can be supported on a pole 22 with channel brackets 12 that attach to the pole with adjustable clamps 14. The banner 10 can span between two channel brackets 12 on each side of the pole 22, allowing the banner 10 to be made in various lengths (the span between the channel brackets 12) and various widths (the length of the channel brackets 12). Unlike conventional side mounted banners, which are limited in width due to the side mount design, the banners of the present invention can be significantly wider, typically as wide as about five feet, allowing the message on the banner display space 20 to be more visible and understandable.

Anti-slip, protective pads, such as Neoprene pads 18 can be attached to the pole 22 at the appropriate height for placement of the channel brackets 12. In some embodiments, the pads 18 can be disposed only on a portion of the pole 22 where the channel brackets 12 are to be placed, as shown in the Figures. However, in some embodiments, the pads 18 can be disposed about the entire periphery of the pole 22. An adjustable clamp, such as a hose clamp 14 can be placed over the pole 22 and the pads 18 to secure the pads 18 to the pole 22. In some embodiments, the hose clamp 14 can be a quick release clamp. The



hose clamps **14** can also pass through center slots of the channel brackets **12**, as shown in FIG. **2**, for example, to secure the channel brackets **12** to the pads **18**, which are secured to the pole **22**.

The channel brackets **12** can be disposed on opposite sides of the pole **22**, with a first set of two channel brackets **12** disposed on a first height of the pole **22**, and a second set of two channel brackets **12** disposed on a second height of the pole **22**. Hose clamps **14** can be used to span between the two channel brackets **12** at the first height, typically, one hose clamp **14** on each side of the pole **22**, and another hose clamp **14** can be used to span between the two channel brackets **12** at the second height, typically one hose clamp **14** on each side of the pole **22**. The hose clamps used to hold the channel brackets **12** against the pole **22** can be the same or different in design from the hose clamps used to secure the pads **18** to the pole **22**.

The banner **10** can have a wrap-around portion **10C** designed to wrap around the channel bracket **12** to a back side thereof. The wrap-around portion **10C** can include a reinforced region with a hole there through, such as a grommet **26**. A tie wrap **16A** can fit through the grommet **26** and be secured to the channel bracket **12** through a channel slot **24** formed therein. At least one grommet **26** can be disposed on each corner of the banner **10** in the wrap-around portion **10C** thereof, however, more than one such grommet **26** can be disposed in the wrap-around portion **10C**. The tie wraps **16A** can be secured to the channel bracket **12** such that tightening the tie wrap **16A** pulls the banner **10** taut between the channel brackets **12**.

A banner cut out region **10B** can be designed so that the wrap-around portion **10C** does not extend to where the channel brackets **12** attach to the pole **22**. The cut out region **10B** can be reinforced and can be about 1.5 inches high and from about 6 to about 8 inches wide. This cut out region **10B** allows the banner wrap-around portion **10C** to be wrapped around the channel bracket **12** without having excess banner **10** that cannot wrap around the channel bracket **12** at the location of the pole **22**.

In some embodiments, as shown in FIG. **5**, an additional tie wrap **16B** can extend from the grommet **26** out to the end of the channel bracket **12**. This tie wrap **16B** can be designed so that tightening of the tie wrap **16B** pulls the banner **10** widthwise, creating a further mechanism to make the banner **10** taut horizontally.

In some embodiments, as shown in FIG. **6**, a channel strut **34** can be disposed, parallel to the longitudinal axis of the pole **22**, where each channel bracket **12** meets the pole **22**. The channel strut **34** can be a slotted channel that can be strapped to the pole using a plurality of clamps **14**, typically three clamps **14**. A T-brace **30** can attach to the channel strut **34** and extend outwards from the channel strut **34** at 90 degree angles from each side thereof. The channel bracket **12** can then be secured to the T-brace **30**, by, for example, cone nuts **32**. In some embodiments, a total of four channel struts **34** can be deployed, one for each location where each channel bracket **12** meets the pole **22**. In other embodiments, two channel struts **34** can be used, one spanning between two front channel brackets and one spanning between two rear channel brackets. In this embodiment, two T-braces **30** are disposed on each channel strut **34**.

While the Figures show the pole **22** as being a round pole, the banner system of the present invention can be installed on any shape of vertical pole using any number or configuration of clamps **14** required for that configuration.

The channel brackets **12** can be made of various materials, such as aluminum, steel, and the like, typically galvanized

steel. While the channel brackets **12** are shown as C-shaped, various shapes, such as round or square, for example, could be used with holes drilled therethrough for the channel slots **24**. While the above discusses the use of Neoprene pads, other pad materials, such as rubber, can be used. The hose clamps can be made from various materials, such as steel, stainless steel, or the like. The zip ties can be plastic zip ties and, where necessary, can be designed to be resistant to ultraviolet rays to prevent breakdown over time for banners that may be displayed over long periods of time.

The banner system of the present invention can be used in various locations, including, for example, light poles in retail parking lots, city streets, college campuses, and the like. Unlike conventional banners that are often hard to read and decipher, ripped, or blown off altogether, the banner system of the present invention can provide banners of desirable sizes to be securely and safely mounted on poles and other similar mounting structures.

It should be understood, of course, that the foregoing relates to exemplary embodiments of the invention and that modifications may be made without departing from the spirit and scope of the invention as set forth in the following claims.

What is claimed is:

1. A pole bracket and banner system comprising:

- a first set of two channel brackets disposed at a first height on a pole;
- a second set of two channel brackets disposed at a second height on the pole;
- a plurality of channel slots in the first and second sets of two channel brackets;
- a first adjustable strap disposed about the pole at the first height, the first adjustable strap extending into one of the plurality of channel slots on each of the first set of two channel brackets and exiting from an adjacent one of the plurality of channel slots on each of the first set of two channel brackets, where tightening the first adjustable strap to the pole secures the first set of two channel brackets at the first height;
- a second adjustable strap disposed about the pole at the second height, the second adjustable strap extending into one of the plurality of channel slots on each of the second set of two channel brackets and exiting from an adjacent one of the plurality of channel slots on each of the second set of two channel brackets, where tightening the second adjustable strap to the pole secures the second set of two channel brackets at the second height;
- a first set of two adjustable straps extending about and interconnecting the first set of two channel brackets on each side of the pole; and
- a second set of two adjustable straps extending about and interconnecting the second set of two channel brackets on each side of the pole.

2. The pole bracket and banner system of claim 1, further comprising a banner extending between one of the first set of two channel brackets and one of the second set of two channel brackets.

3. The pole bracket and banner system of claim 2, wherein the banner includes a banner cut-out region disposed in a region where the channel brackets contact the pole.

4. The pole bracket and banner system of claim 2, wherein the banner includes at least one grommet in a banner wrap-around region disposed on each corner of the banner.

5. The pole bracket and banner system of claim 4, further comprising zip ties securing the grommets of the banner to the channel brackets.

6. The pole bracket and banner system of claim 1, wherein each of the adjustable straps are quick release adjust straps.



## 5

7. The pole bracket and banner system of claim 1, further comprising an anti-slip protective pad disposed between the channel brackets and the pole.

8. The pole bracket and banner system of claim 7, wherein the anti-slip protective pad is a neoprene pad.

9. A banner display system comprising:

a first set of two channel brackets disposed at a first height on a pole;

a second set of two channel brackets disposed at a second height on the pole;

an anti-slip protective pad disposed between the channel brackets and the pole;

a plurality of channel slots in the first and second sets of two channel brackets;

a first adjustable strap disposed about the pole at the first height, the first adjustable strap extending into one of the plurality of channel slots on each of the first set of two channel brackets and exiting from an adjacent one of the plurality of channel slots on each of the first set of two channel brackets, where tightening the first adjustable strap to the pole secures the first set of two channel brackets at the first height;

a second adjustable strap disposed about the pole at the second height, the second adjustable strap extending

## 6

into one of the plurality of channel slots on each of the second set of two channel brackets and exiting from an adjacent one of the plurality of channel slots on each of the second set of two channel brackets, where tightening the second adjustable strap to the pole secures the second set of two channel brackets at the second height;

a first set of two adjustable straps extending about and interconnecting the first set of two channel brackets on each side of the pole;

a second set of two adjustable straps extending about and interconnecting the second set of two channel brackets on each side of the pole;

a banner extending between one of the first set of two channel brackets and one of the second set of two channel brackets;

a banner cut-out region disposed in a region where the channel brackets contact the pole; and

at least one grommet in a banner wrap-around region disposed on each corner of the banner.

10. The banner display system of claim 9, wherein the anti-slip protective pad is a neoprene pad.

\* \* \* \* \*